

THE PROCESS

Julie Hilmersen and Nora Paulsen

INTRODUCTION.....	03
COMMUNICATION.....	04
SPATIAL STUDIES.....	12
FACADE AND MATERIALS.....	24
SURROUNDINGS.....	35
PROGRAM.....	41

INTRODUCTION

When working with the complex we have used different methods for the analysis and the design process. We started out by analysing drawings from archives, trying to figure out what, how and when it was built. Visits to the site with photo and video documentation in addition to measuring with a laser, was helpful when we documented the existing buildings, as well as reading the municipal master plans and books about the place.

Long walks around Nyhavna and the surrounding area, talking to locals, documenting the uses and the spaces, has been an important part of the analysis of the area. We have also talked to city planners, developers and urbanists that are involved in the area and the upcoming changes. We visited some local projects as well, to find inspiration for the program.

We started the design process by making hand drawings and simple sketches for concepts and design thoughts. Making hand drawings instead of computer drawings has been important throughout the process because it gives you more freedom to create unique shapes.

We made models to test the spatial qualities, to see what the rooms we had drawn would feel like. Through models we have worked with light, compositions of shapes and openings in the façade. The complexity of the buildings have been difficult to comprehend, so we found it helpful to work with models in clay and kinetic sand. Working with models was important during the first part of the semester, but unfortunately it became difficult to continue making models when our workshop closed due to the Corona crisis.

For inspiration we have also studied reference projects that deal with transformation of industrial buildings, like “la Fabrica” from Ricardo Bofill and the MOCAA museum in Cape Town.



COMMUNICATION

THE BIG SILO STAIRCASE

Getting around the complex was naturally one of the first tasks to solve and proved to be a difficult one. In the first sketches we drew a big staircase that would fill one of the silos. We were uncertain if this would be a good solution because one of the other silos would then always be a hallway, which made it difficult to use in an efficient way.

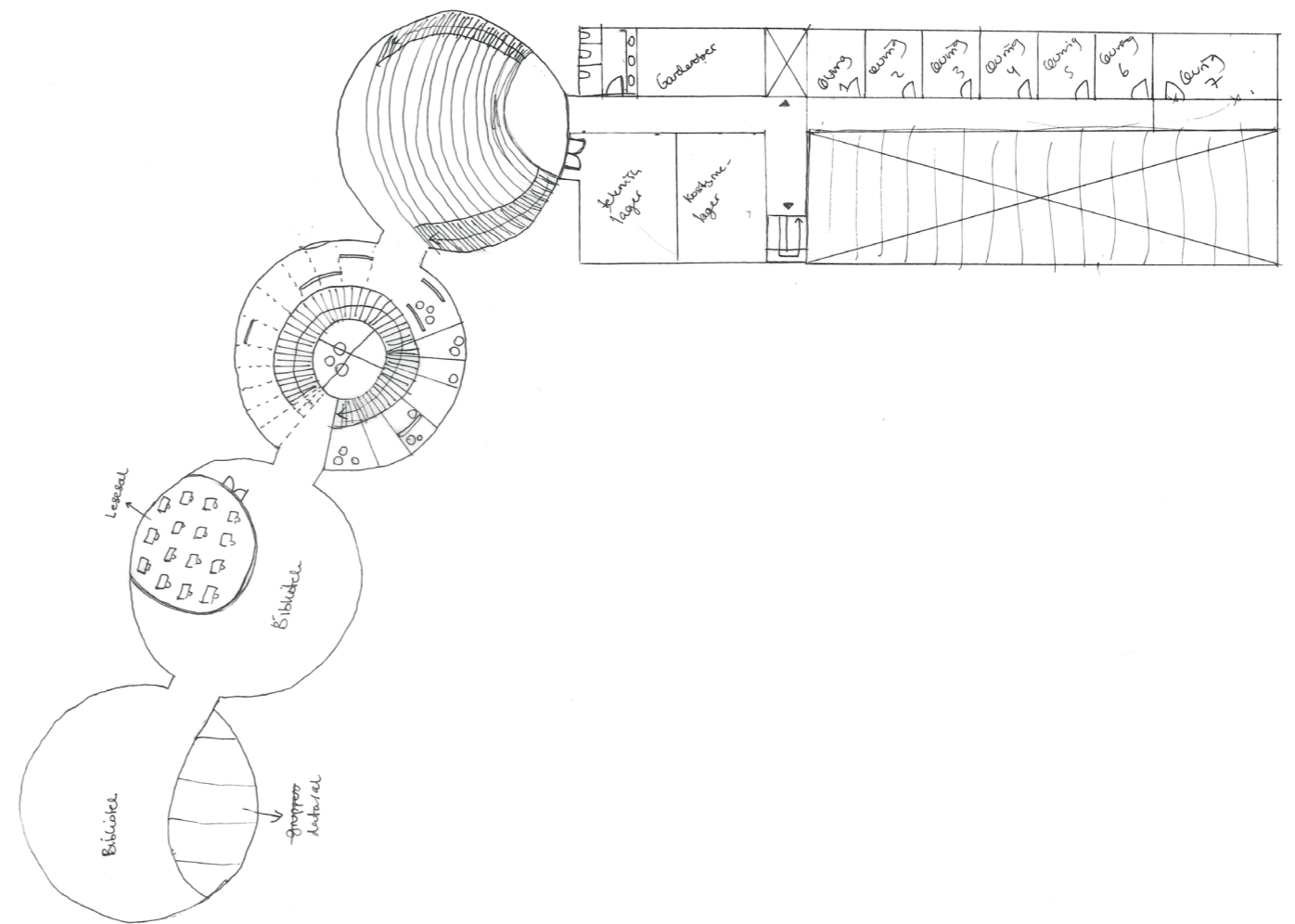

THE OUTSIDE COMMUNICATION

To prevent the creation of a lot of hallways, we tested the possibility of putting the communication outside. That would make it possible to enter each silo from every side. This could be done by building a plateau around it or by walking over bridges connected to verticals. You could also create some kind of structure around it that could contain stairs, inspired by the famous Pompidou center. Another solution could be to put boxes on the outside of the façade, containing stairs.

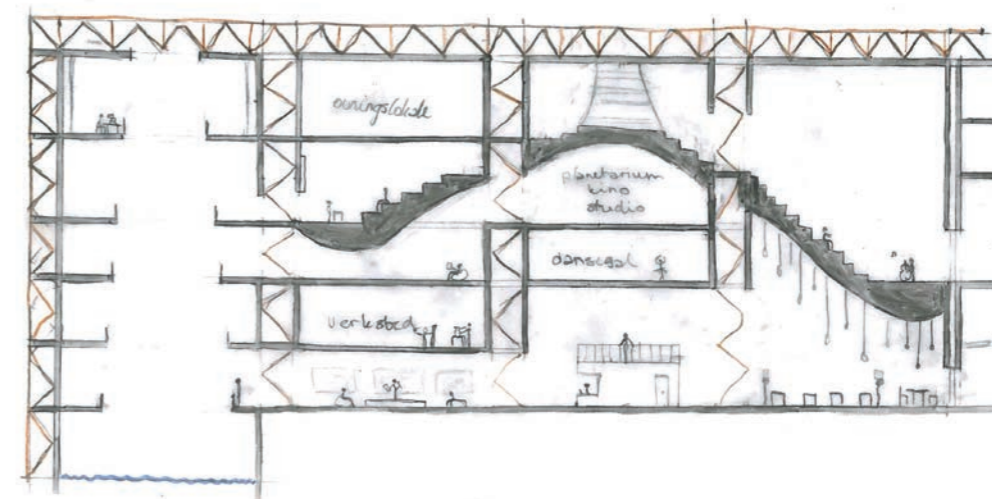
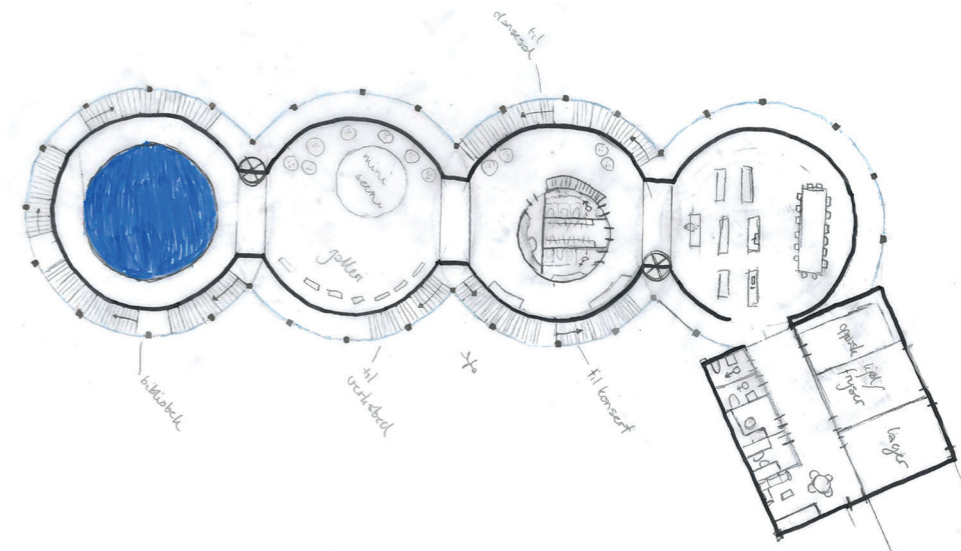
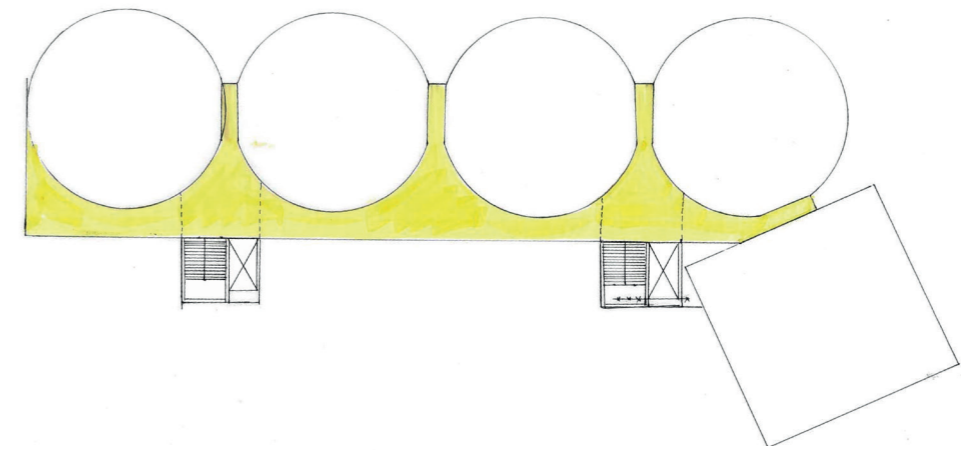
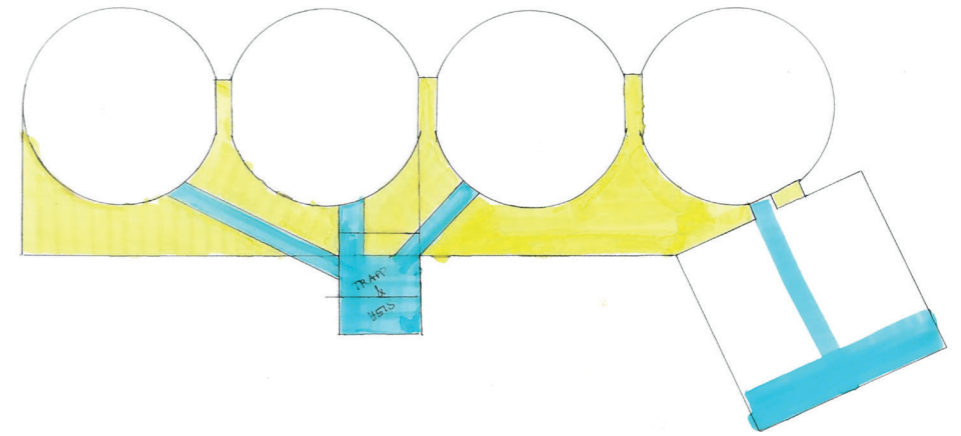

FACADE SYSTEMS FOR SOLVING THE COMMUNICATION

The communication on the outside of the buildings, created some interesting façades.

The upper model shows a façade based on a system of putting boxes on the existing buildings that would have a big glass surface and contain stairs. The other model has a system of wooden structures on the outside that would contain stairs and ramps to get around.

Eventually we did not go any further with these ideas because we thought that the silos would lose some of their verticality and monumentality by making such systems. Neither did it solve the problems of the communication properly.

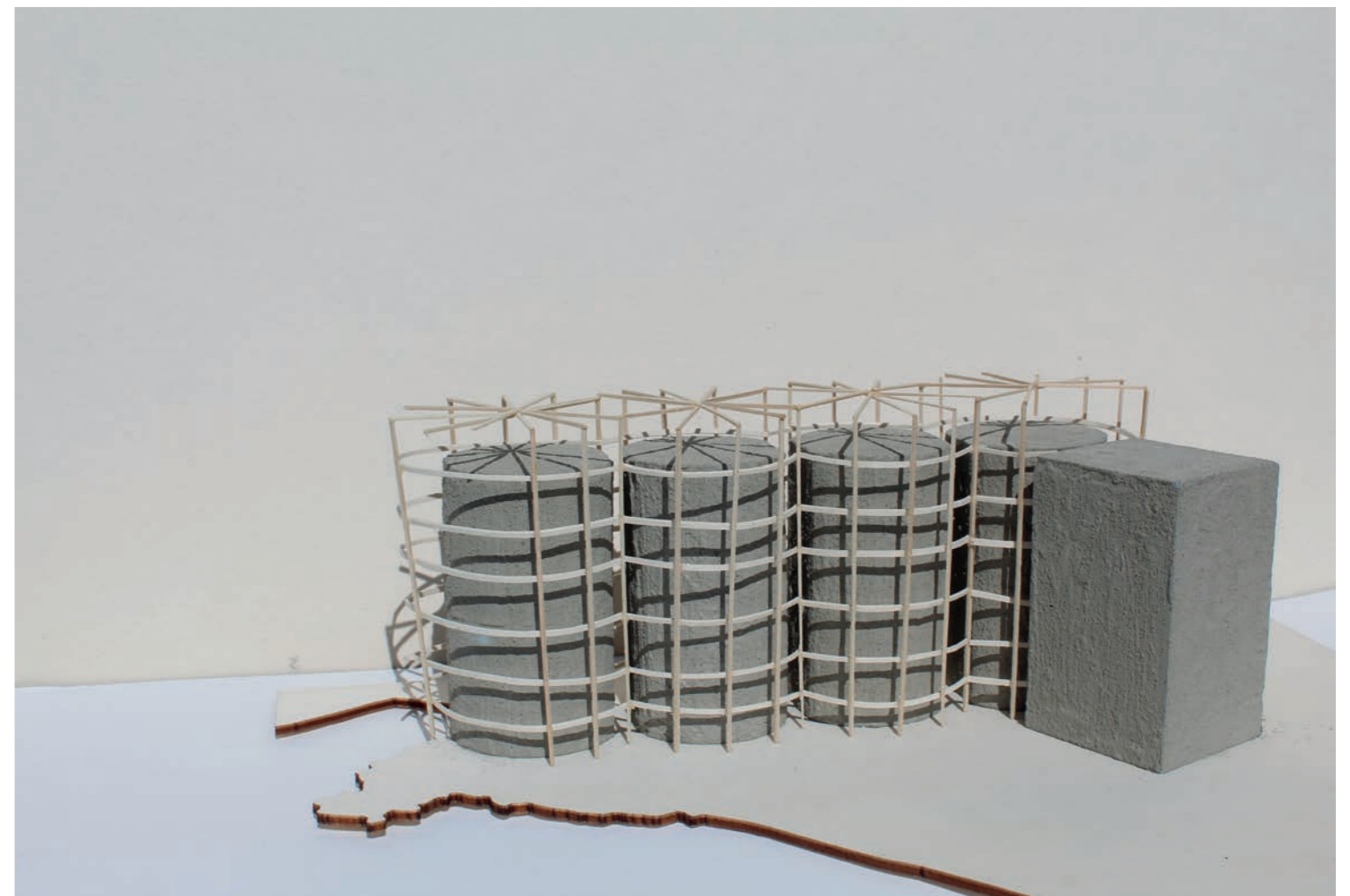
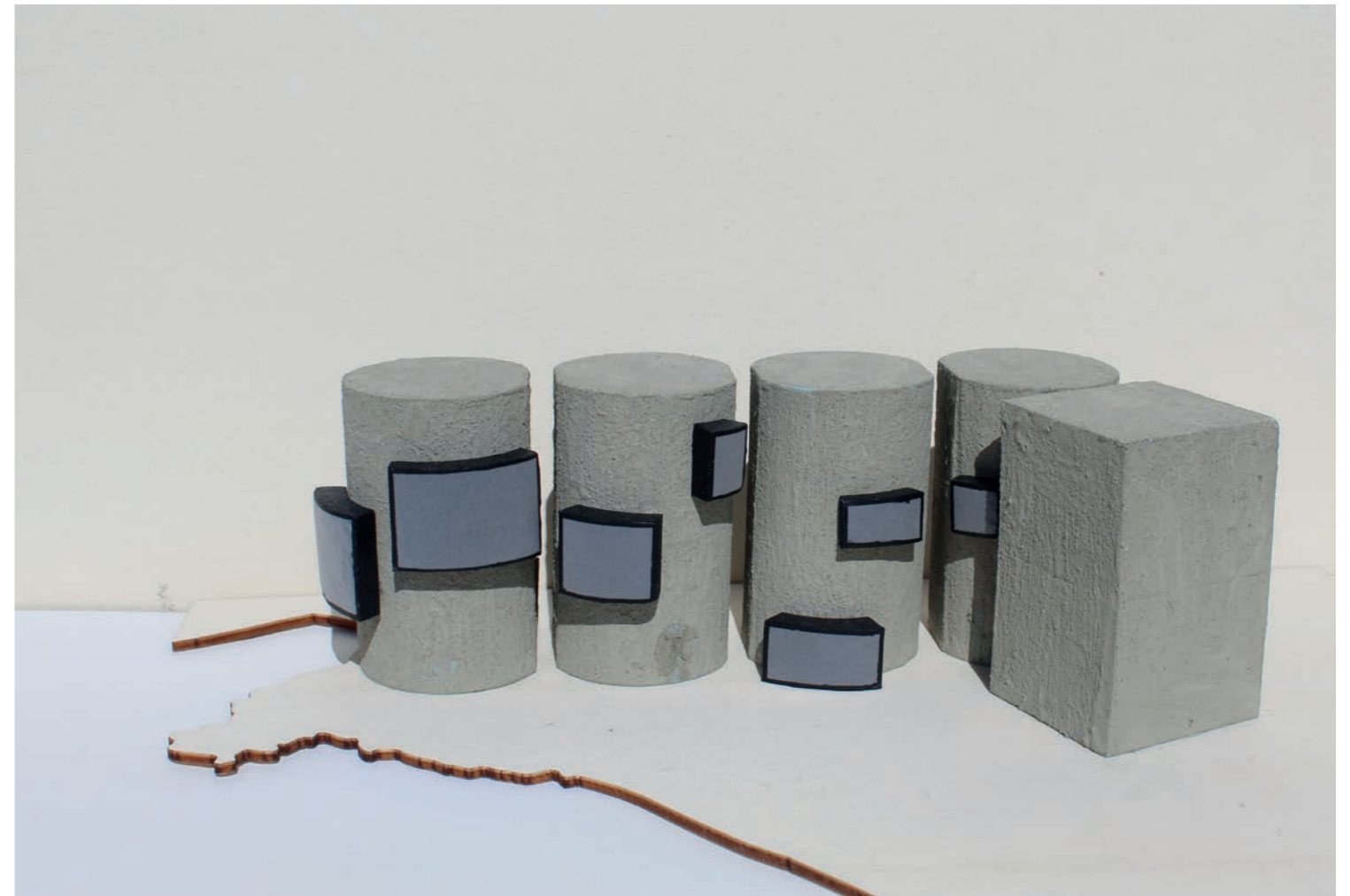

ONCE AGAIN TESTING THE BIG SILO STAIRCASE

After seeing the previous models, we felt that it took away the charm and the soul of the façade. We therefore went back to putting a big staircase in one of the silos. We still had the problem of a lot of hallway. We solved this by making the ground floor completely open and the first floor with a big room on the outer silo, turning only one of the floors in the middle into a hallway. A problem with this solution was the unclarity of how to move inside the buildings. The staircase was not in the entrance silo, which was a bit strange.

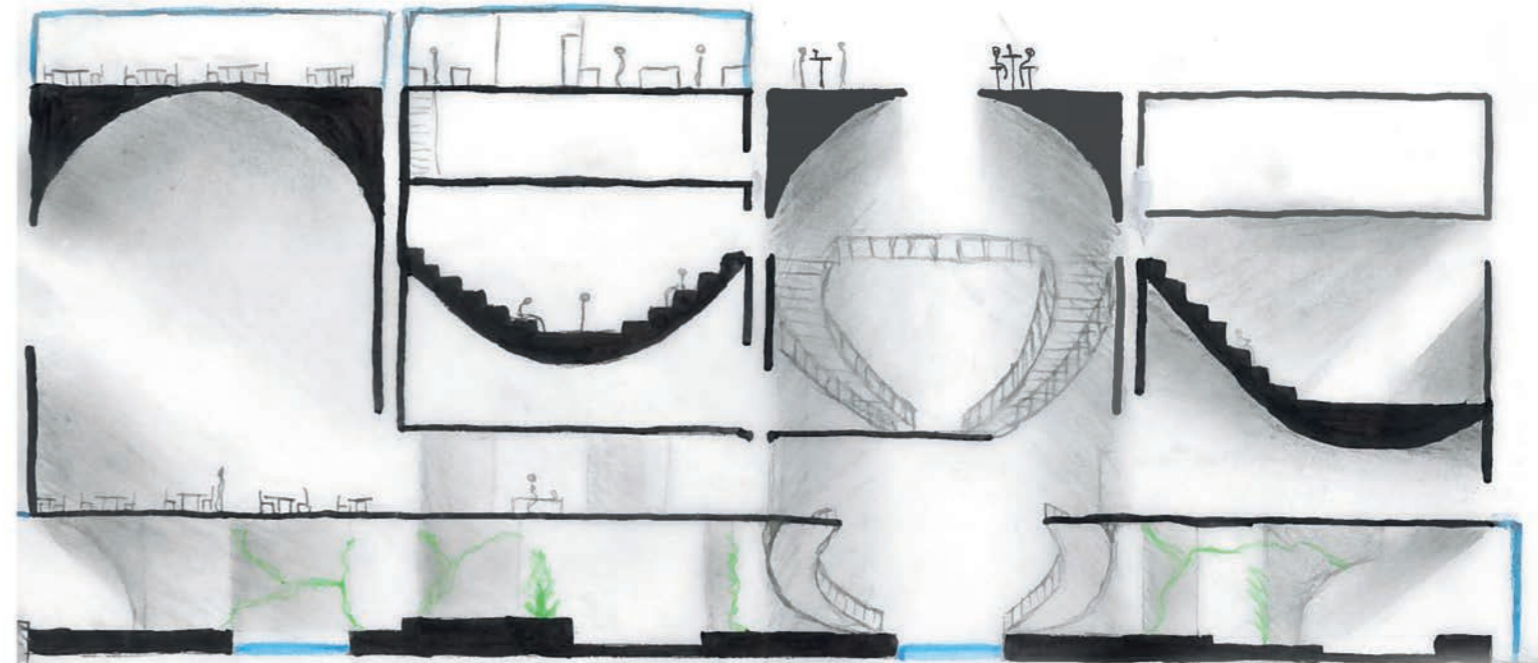

DIFFERENT KIND OF MOVEMENTS INSIDE

Seeing that neither the outside communication nor the big staircase in the middle worked in the way we wanted it to, we started from scratch again. We tried to create a horizontal staircase, crossing several silos.

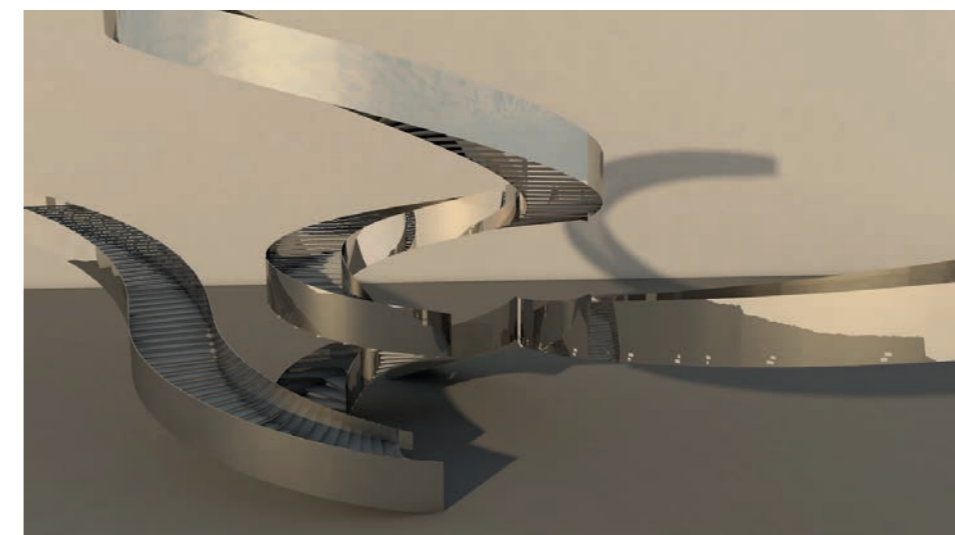
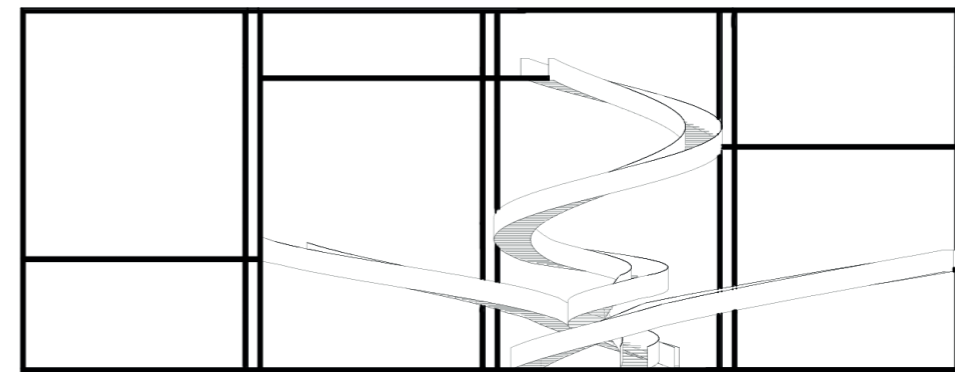
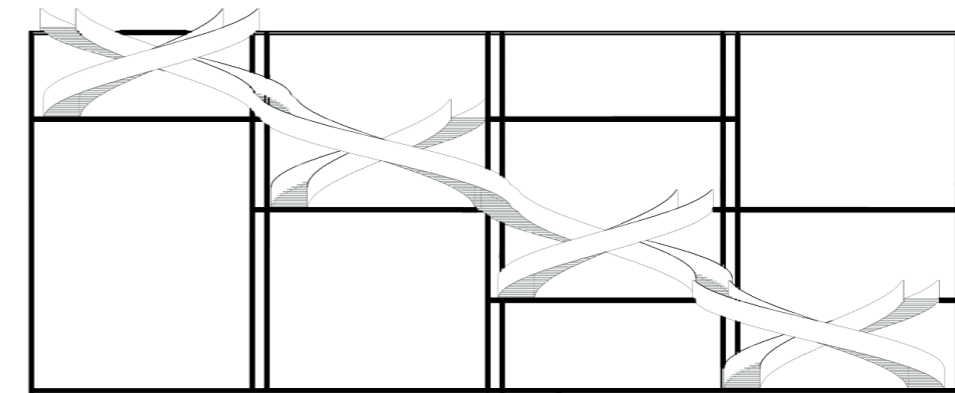
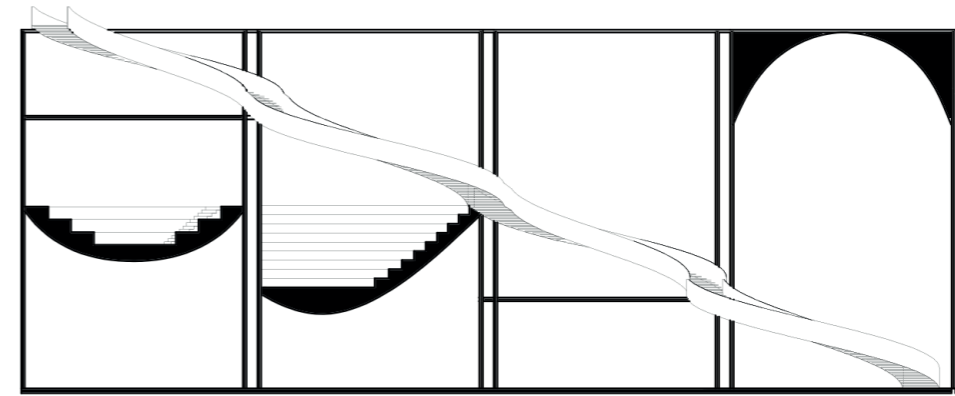

MOVING THE BIG SILO STAIRCASE

The perfect solution to the communication problem always seemed to elude us. The best solution so far was the big staircase in the silo in the middle. Whatever we did, it always created a lot of walk-through spaces. We started to think in a new way; Could we embrace the hallways?

We originally placed the staircase in the silo in the middle so that there would be empty silos at both ends. This would allow them to have a more private program. The problem with this was that the movement around the buildings became unclear and the staircase was not positioned in a logic way on the ground floor. We therefore moved it to the outer silo on the right side, closest to the entry hall. This would make it necessary to walk through even more of the silos, but our new program fits to this kind of movement. The movement is a helix shape, making people walk along the walls.

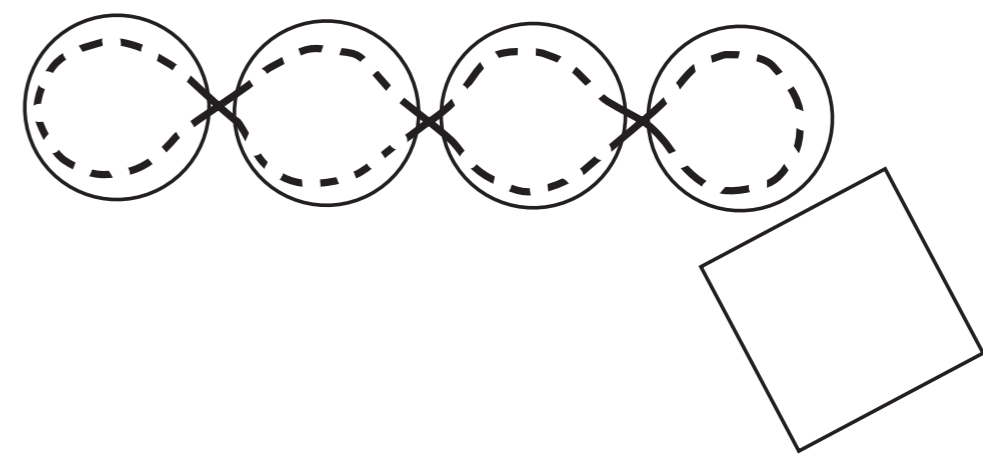

THE COMMUNICATION IN THE SQUARED SILO

The existing staircase in the squared silo is confusing because it changes between being a spiral and a U-shaped staircase. It is quite small and not adapted for commercial use. Therefore, we decided to replace it.

To avoid cutting too much in the existing façade we put a glass box on the south side of the squared silo. This contained the staircase, an elevator and the entrance.

Eventually we thought the entrance and staircase should be moved to the west façade.

We decided that cutting in the façade would be unavoidable because this building would contain functions that need daylight. The point of adding a glass box was then lost.

In the next version we put all vertical communication towards the northern part of the squared silo. This made the entrance and communication clearer.

A problem with this positioning of the stairs was that you would have to walk through a tiny hallway when entering the round silos. We ended up moving the vertical communication to the south side of the building. Now you enter an open space and can clearly see the staircases in both the round and the squared silo from the same spot.

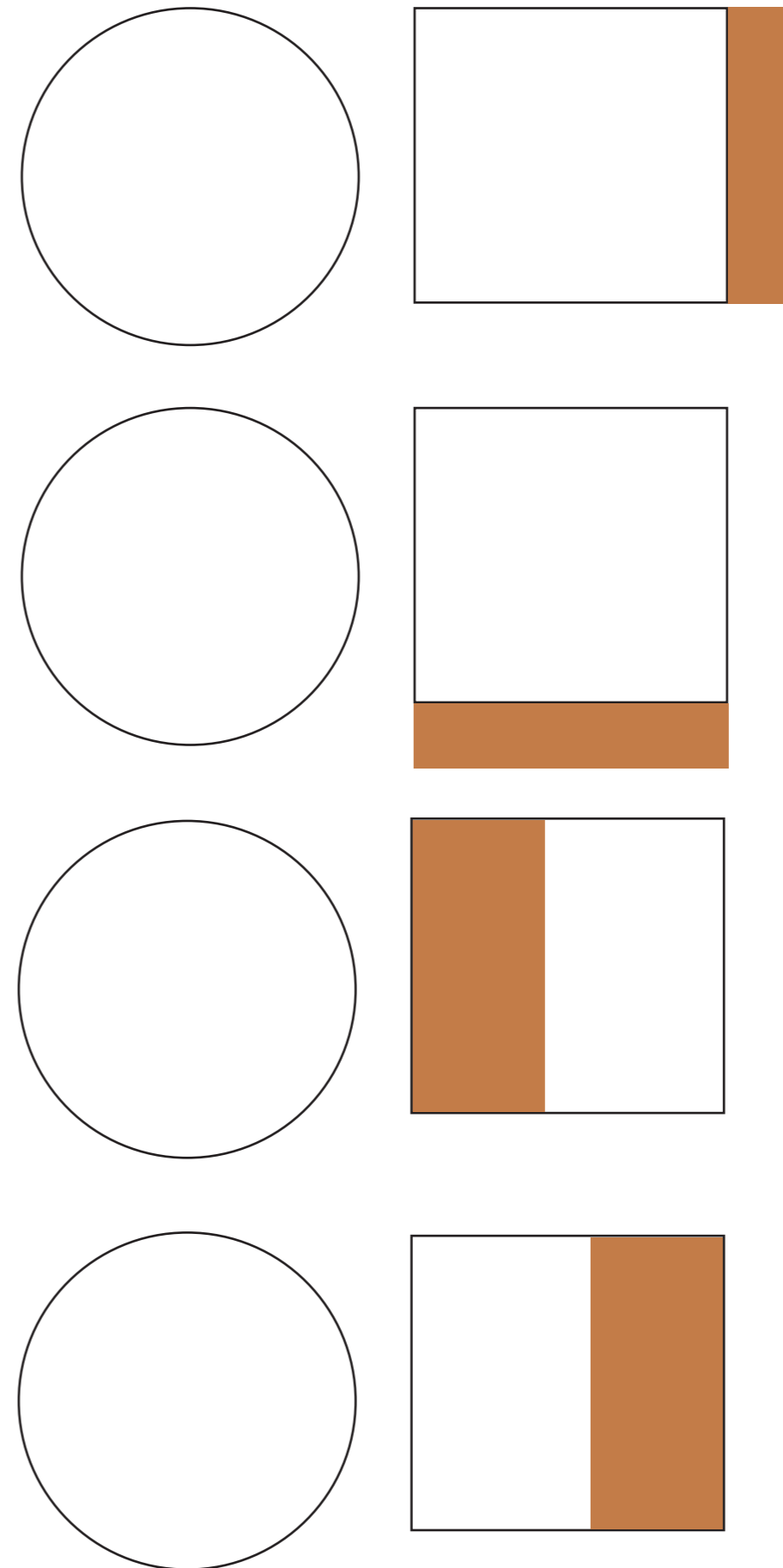

SPATIAL STUDIES

THE WAVE

We started to look at the possibilities inside the four round silos. With the empty silos as a base, we were free to make untraditional floors and ceilings. These drawings show various spatial tests, including amphitheatres and theatres that creates curved ceilings beneath. We really enjoyed the idea of creating weird and interesting spaces that break with the traditional forms.

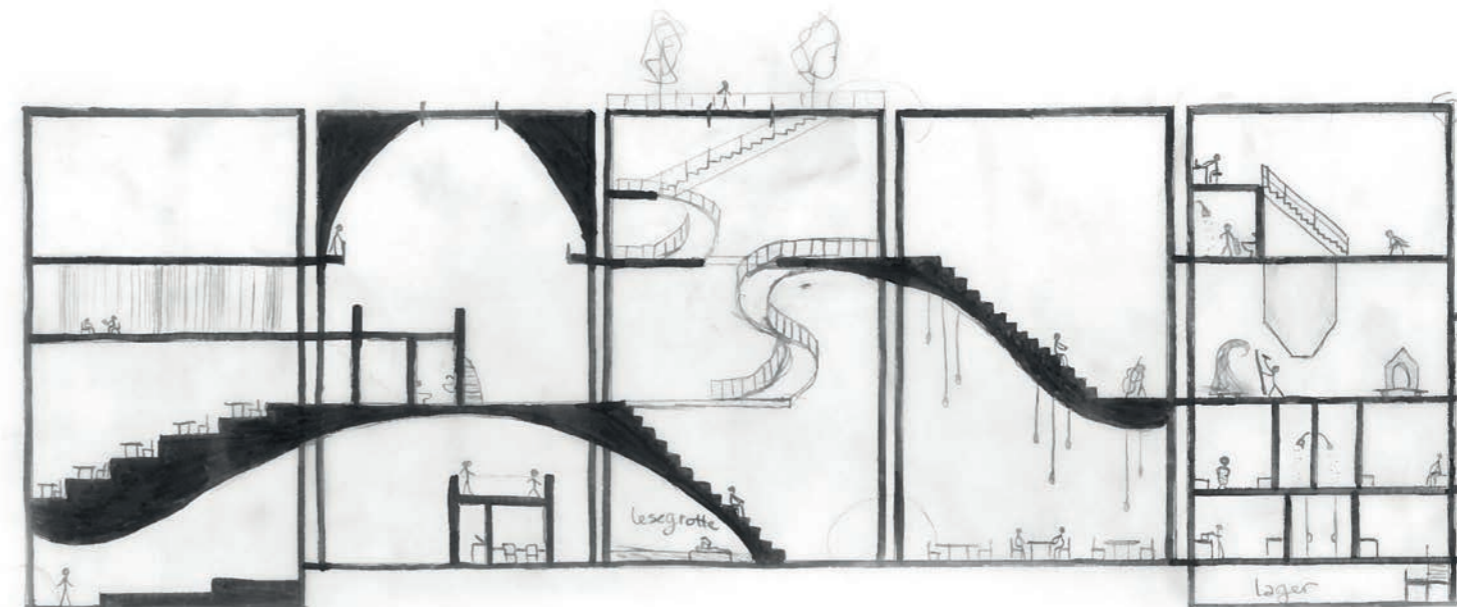
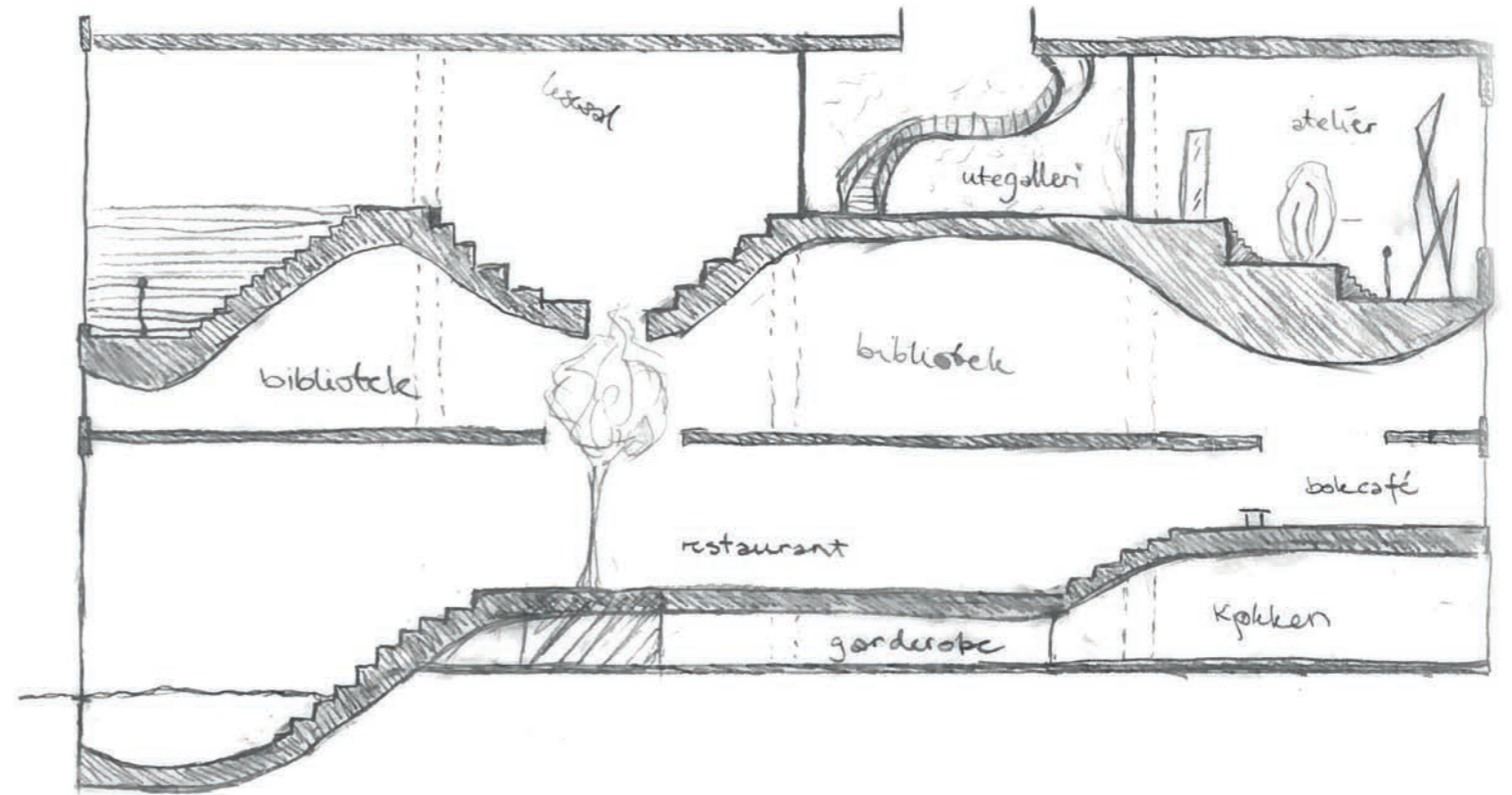

THE WAVE MODEL

To test what it would feel like to be inside these rooms, we made a model focusing on shapes. We also started to experiment with how the daylight could be a beautiful part of the spatial qualities.

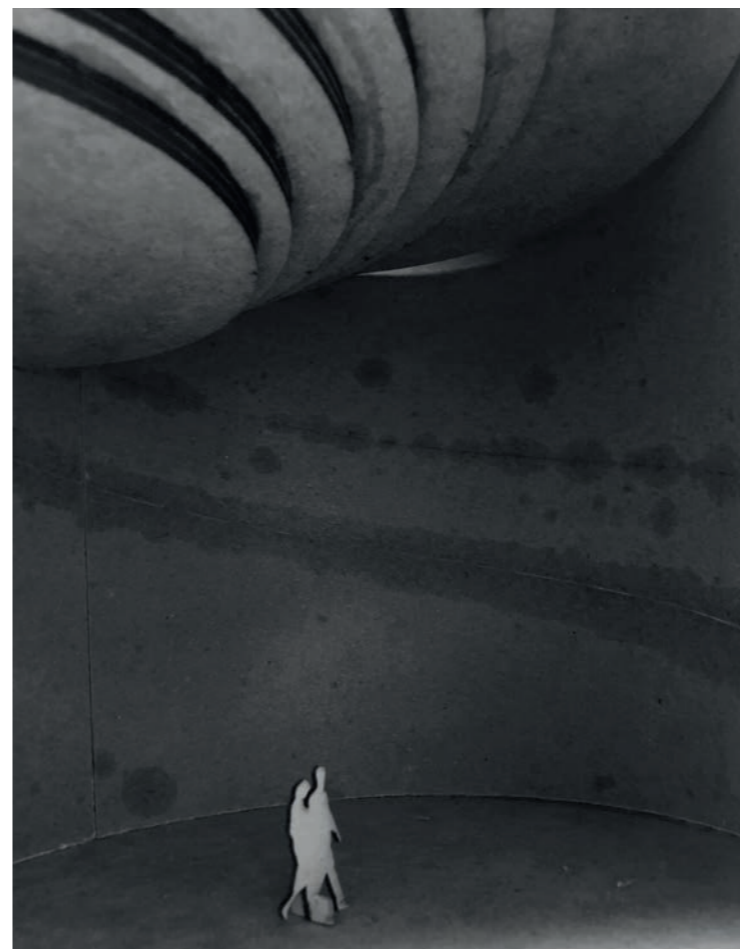

USING KINETIC SAND

When working with such complex shapes it was difficult to express ideas through drawings and models. We therefore used kinetic sand when testing out shapes and communication systems.



MAKING THE WAVE WORK

Making unusual floors and ceilings complicated the logistics within the buildings. To have a lot of spaces that are curved both on top and underneath was too much. We still wanted to keep the spatial qualities we had seen in the wave model, but somehow make it work at the same time. Therefore, we turned the ceiling into a part of the wave, making domes. The shape of the dome gave us a feeling of being inside a cathedral.

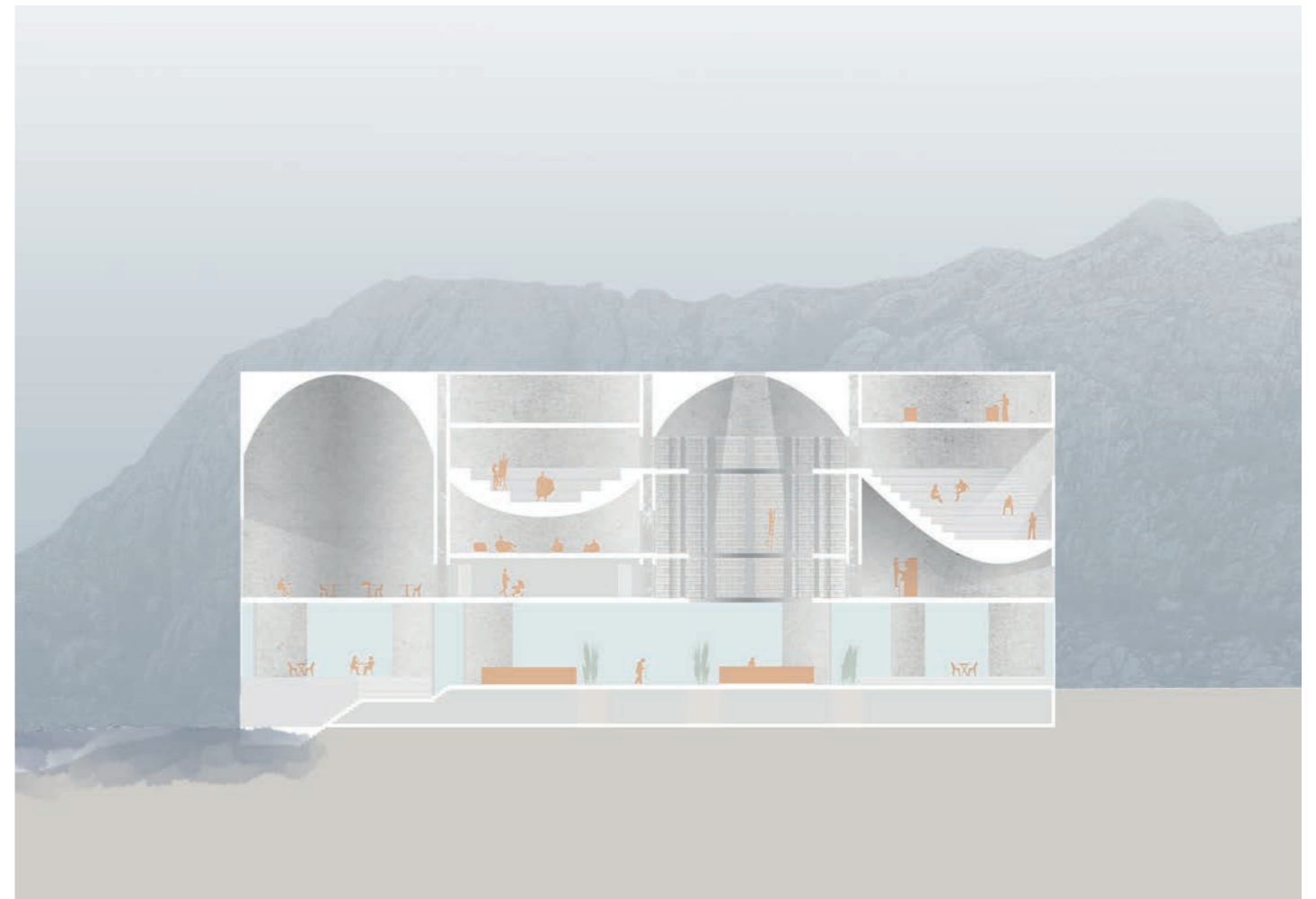

THE DAYLIGHT MODELS

For further studies on how light could be a beautiful part of the project, we made several small models with different kinds of openings. We fell in love with the idea of focusing on one-sided lights in the silos, making it more dramatic and cathedral-like.





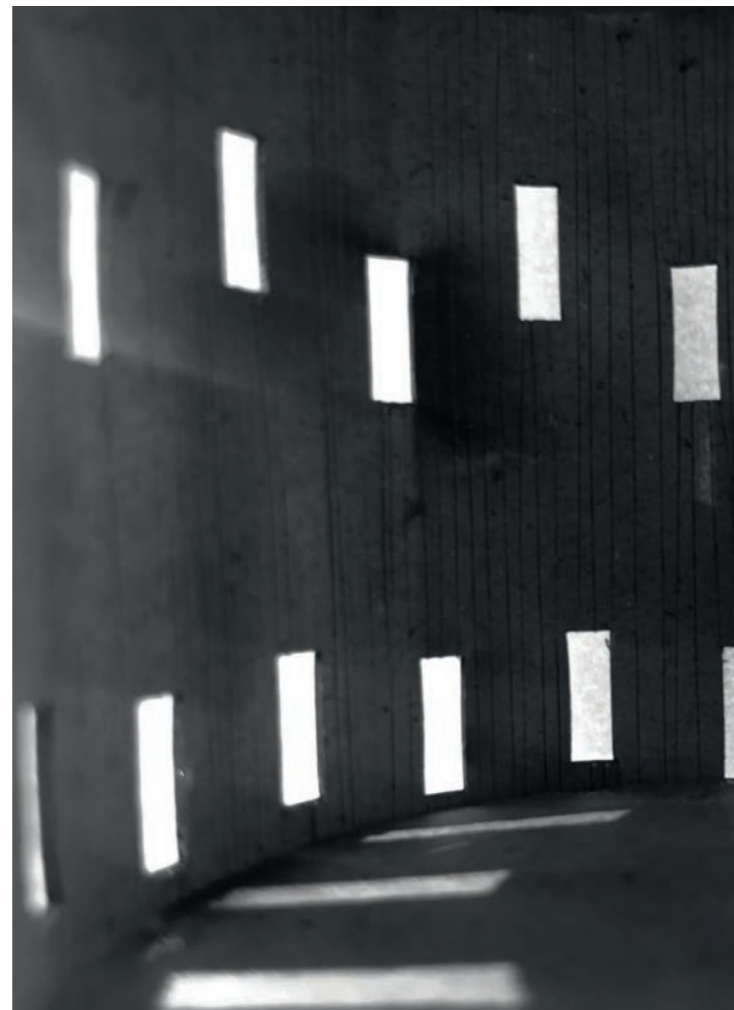

THE MODEL OF THE SILOS

With several studies already done we made a model to see how it would all work together. It showed the light shining through the façade from one side, the curved floors and ceilings, the major staircase and the curved openings between the silos. Being located so close to the water, we saw a big potential in making a connection to it. The photo shows how the stairs lead you down to the water that flows inside of the outer silo.



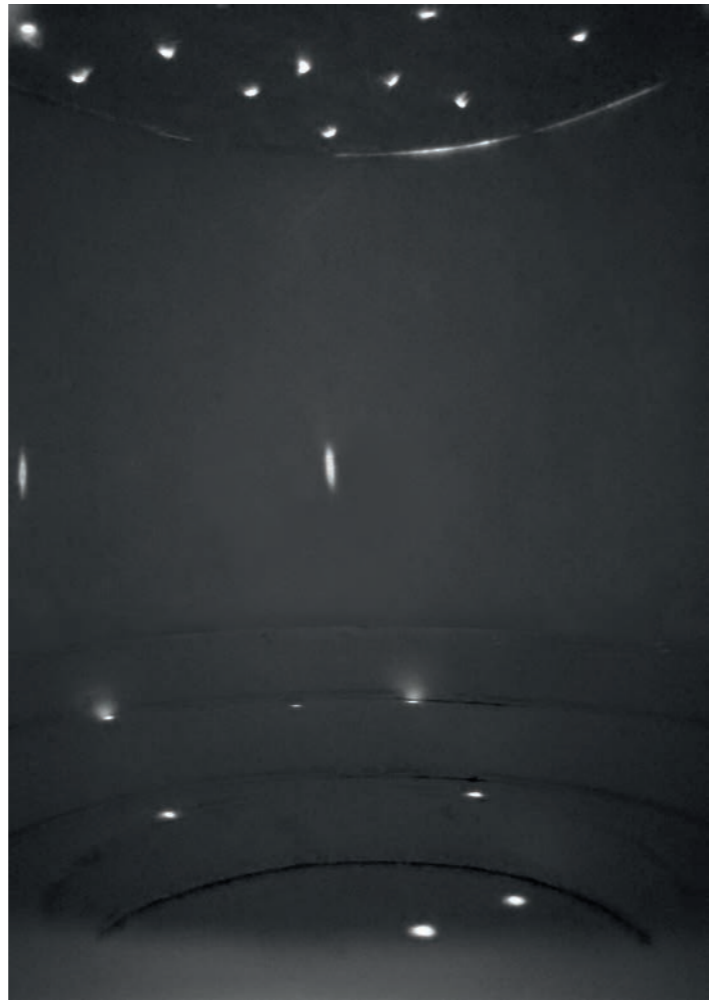
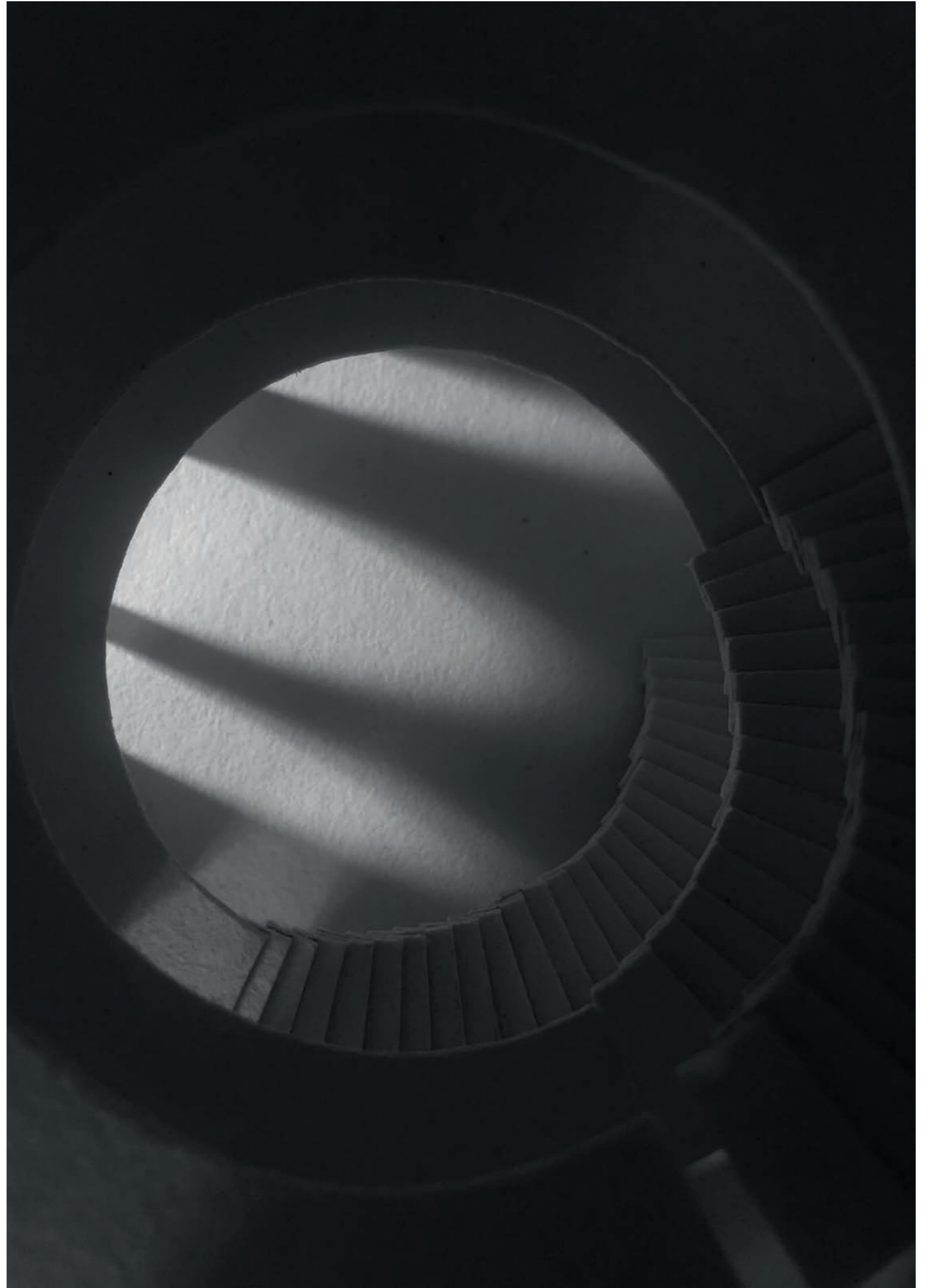

SIGHTLINES

We wanted to create different experiences at different places throughout the silos. These are renders showing the view of the fjord seen from the inner silo.

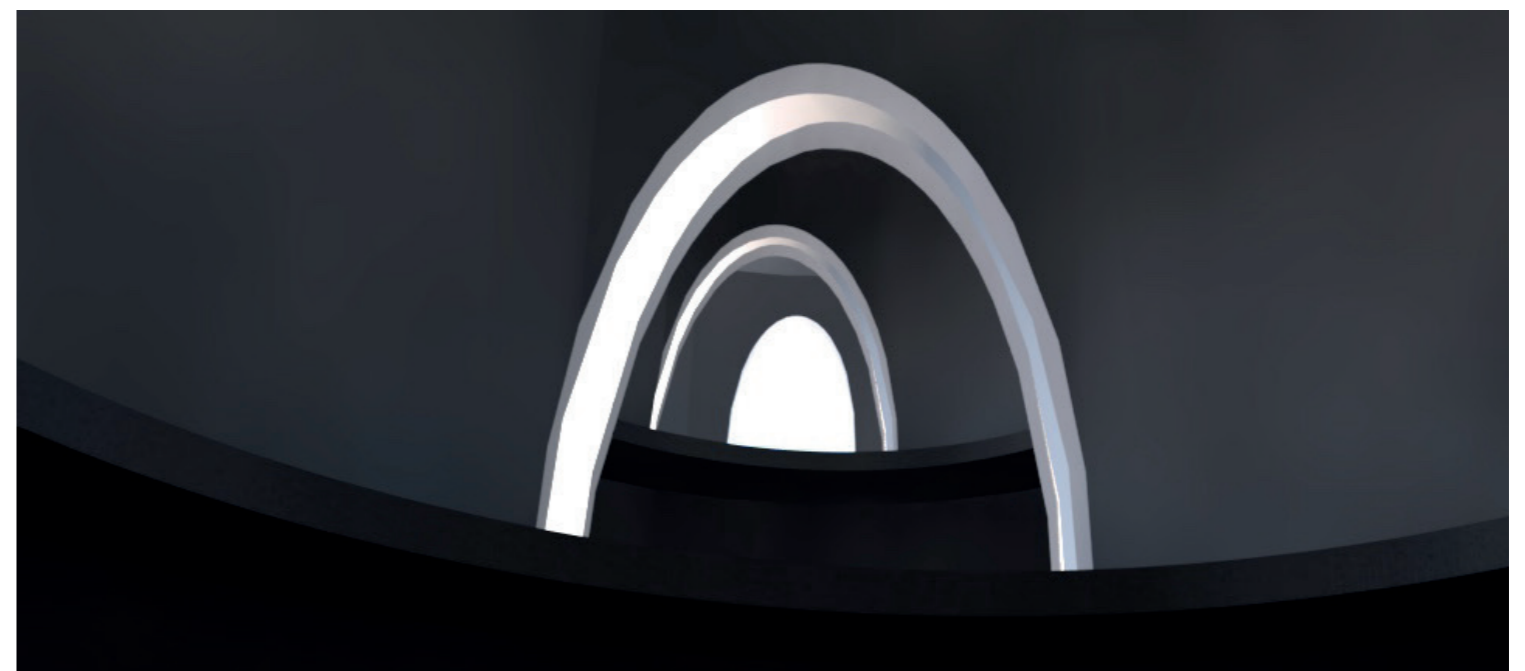

EXPOSED CONSTRUCTION

The domes and the inverted domes had to be carried in some way, and we decided we wanted to expose the construction of all the slabs, domes and inverted domes. We tested different grids of beams before deciding on a radial grid.

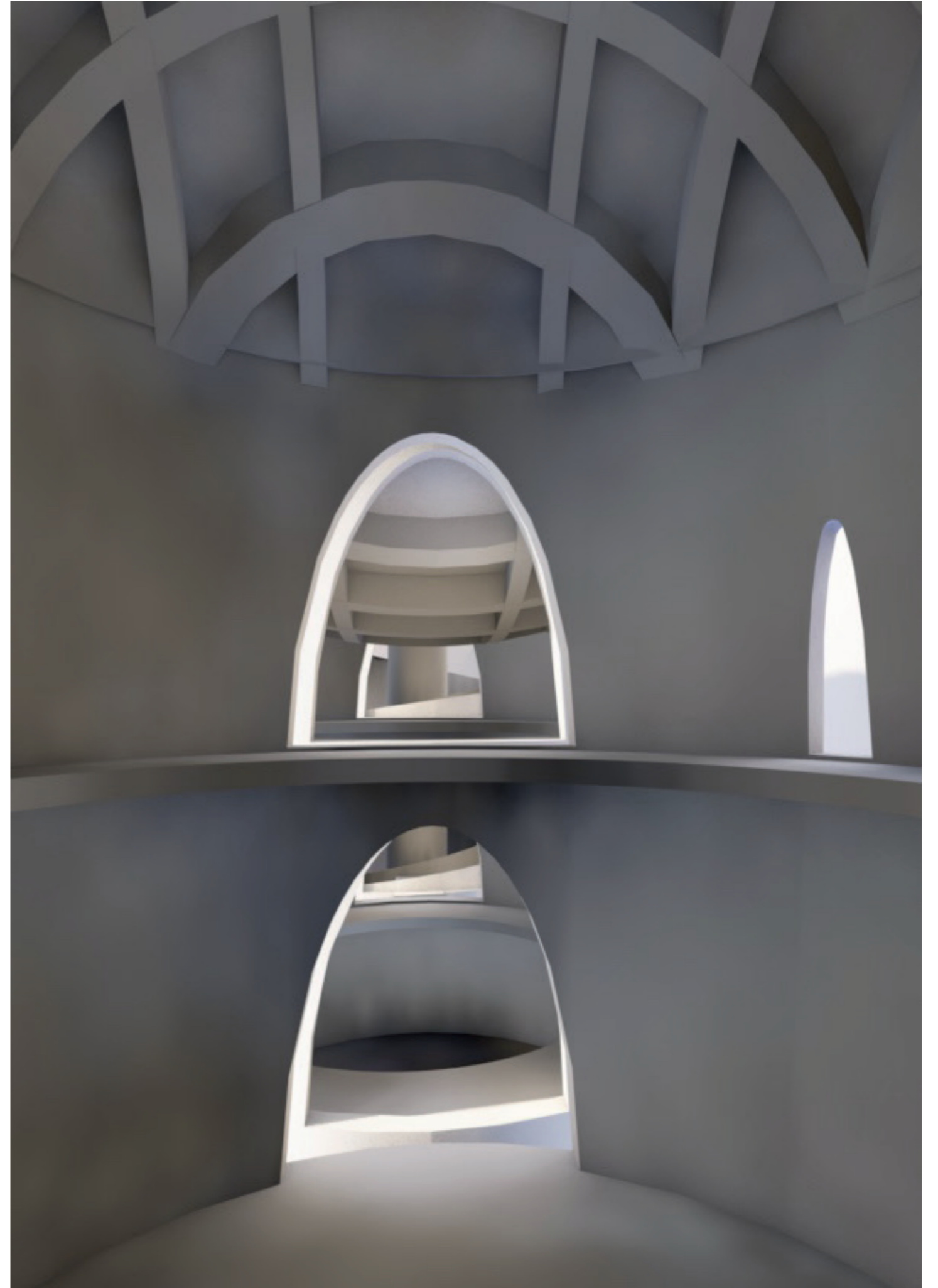

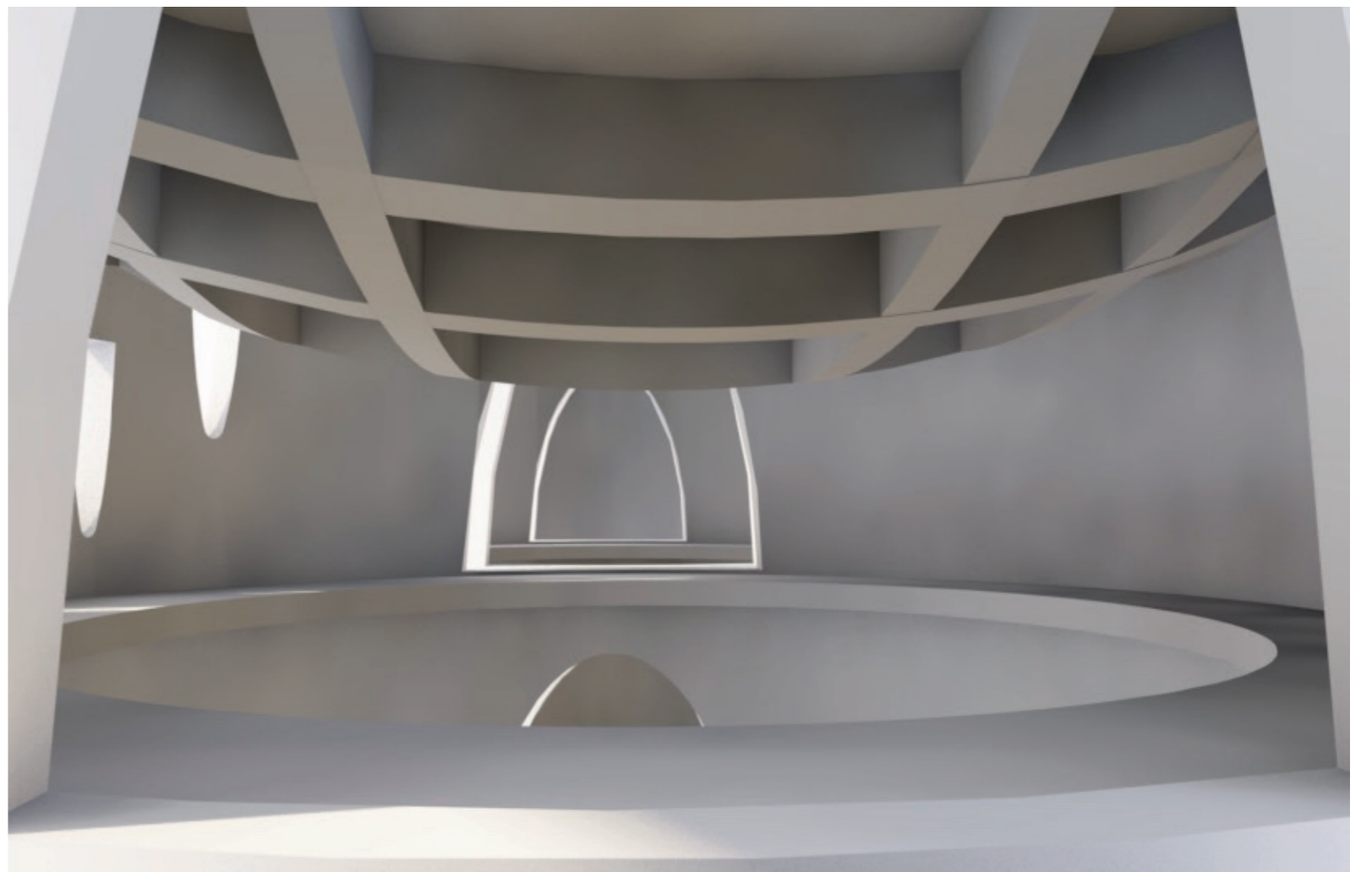

FACADE AND MATERIALS

THE FIRST THOUGHTS OF A NEW FACADE

From early on we wanted the buildings to be open to the public and make a public space in front of them. Therefore, it was natural to open up the façades on the ground floor.

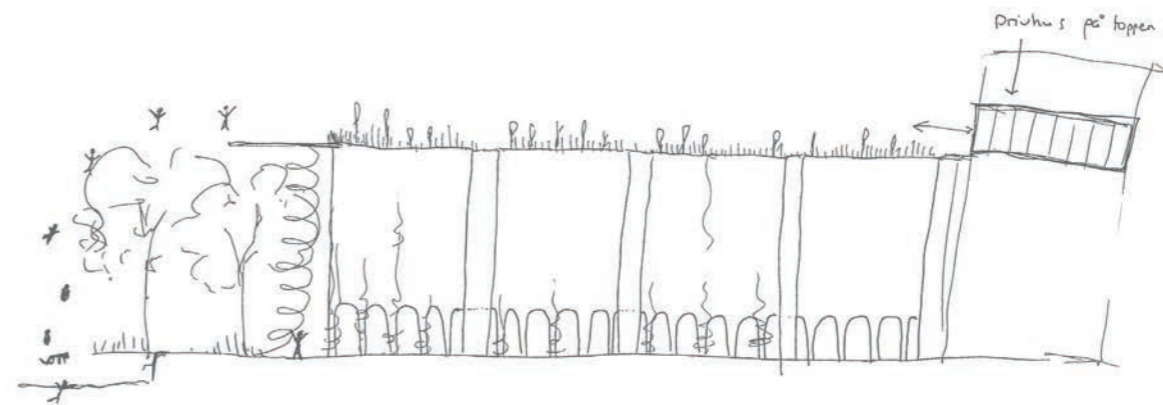

THE FACADE MODELS

We made several models to test different openings in the already existing façades. We figured out that round shapes would fit the round silos better than rectangular openings. As previously mentioned, we wanted the ground floor to be more open than the remaining floors. From these models we saw that too many openings would make the silos less vertical and they would not be anchored to the ground as they are today. It would also create problems regarding construction.

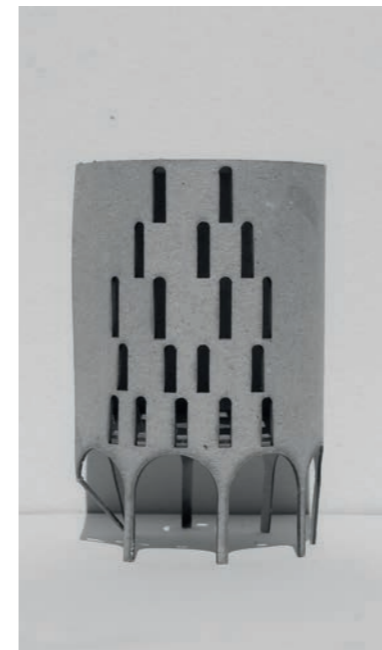
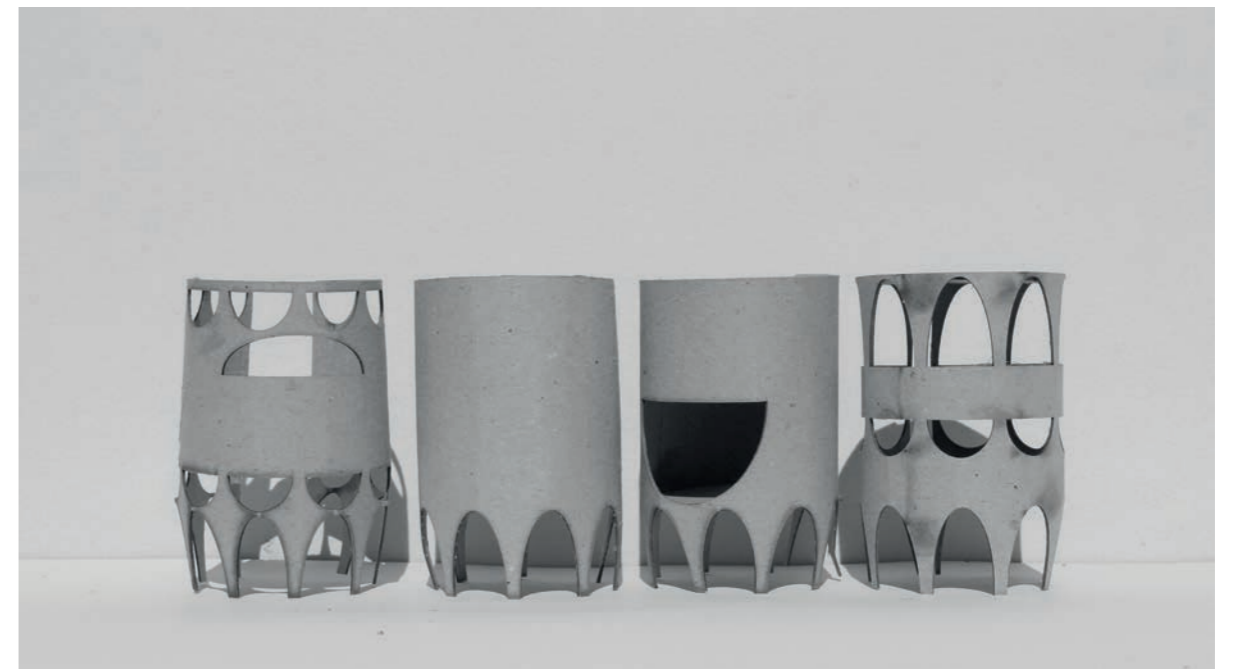

THE MODEL OF THE WHOLE COMPLEX

After doing several tests in the small façade models, we made a model of the whole complex with elements that we liked, like the arches in the ground floor and smaller arch-shaped windows in the upper floors.

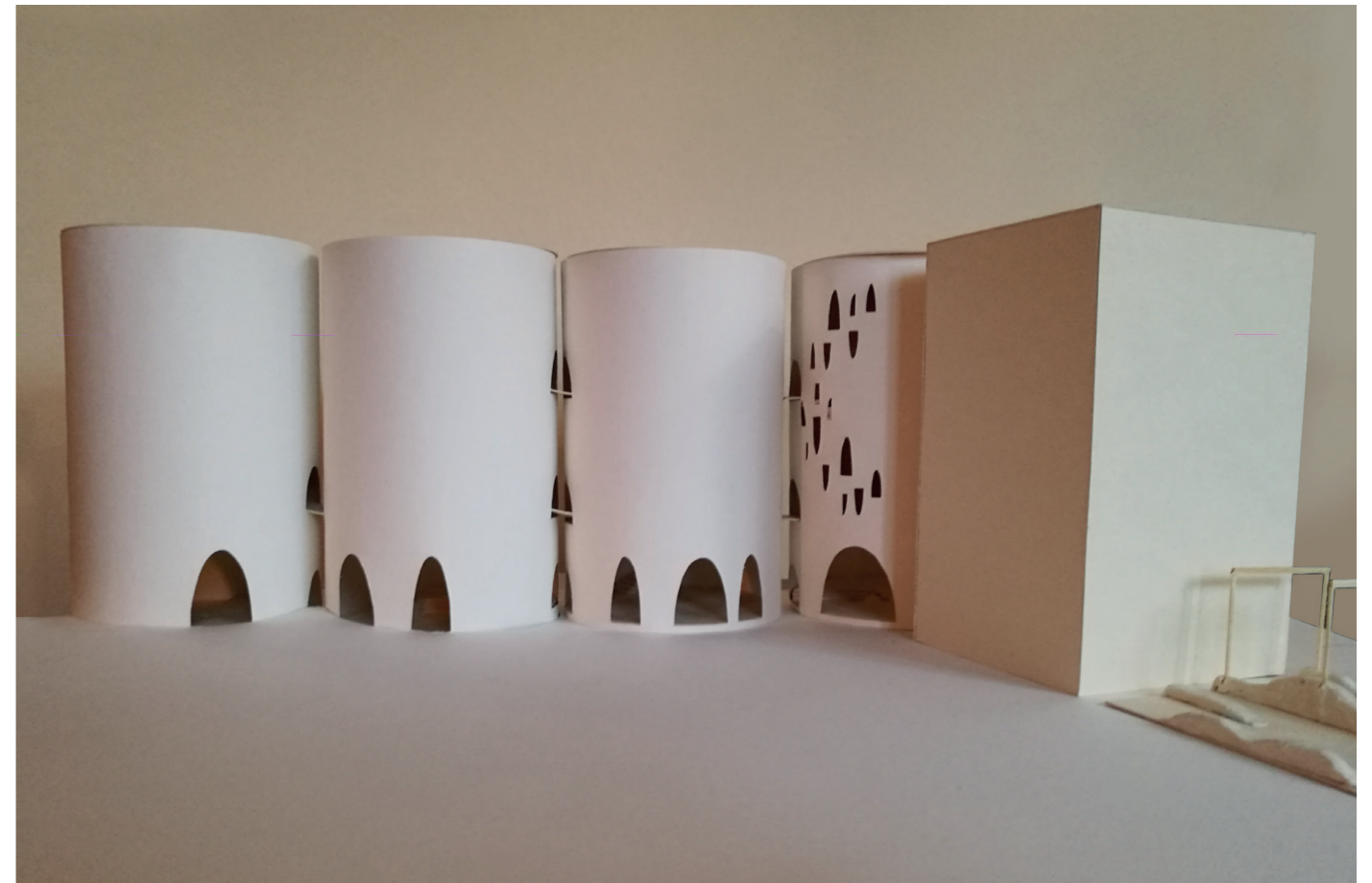

**THE FACADE OF THE SQUARED SILO,
BASED ON THE BEAMS INSIDE**

The squared silo's construction is load bearing walls and beams. This should be kept, and we wanted to express this system in the façade. Making a scheme of how the beams would meet the facade, we could make openings in between them.

Eventually we closed some of the openings because it was not suitable to have windows there. Regarding construction, it was better not to cut out as many openings as originally thought.

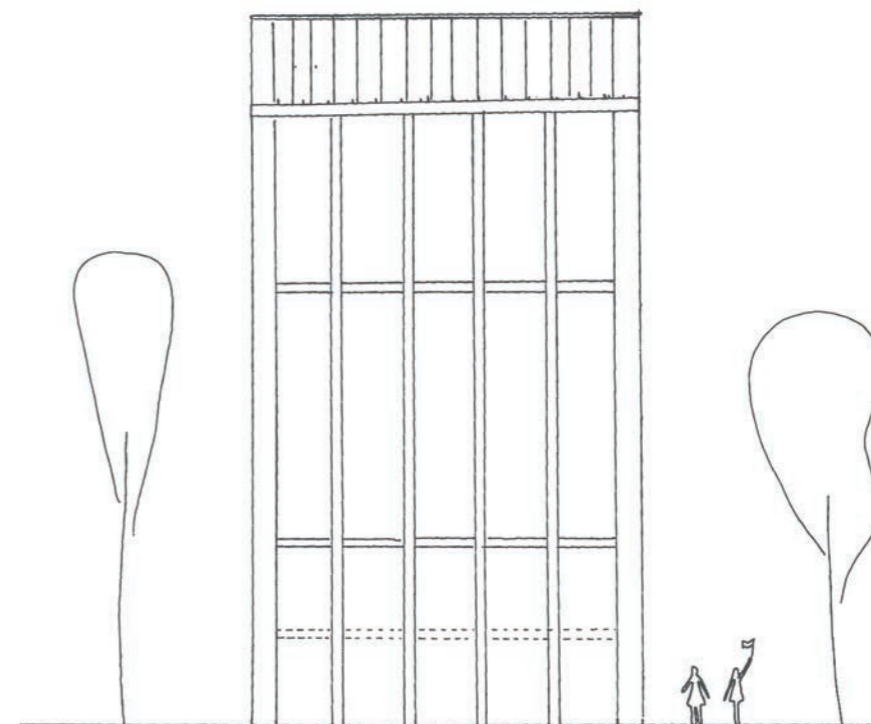
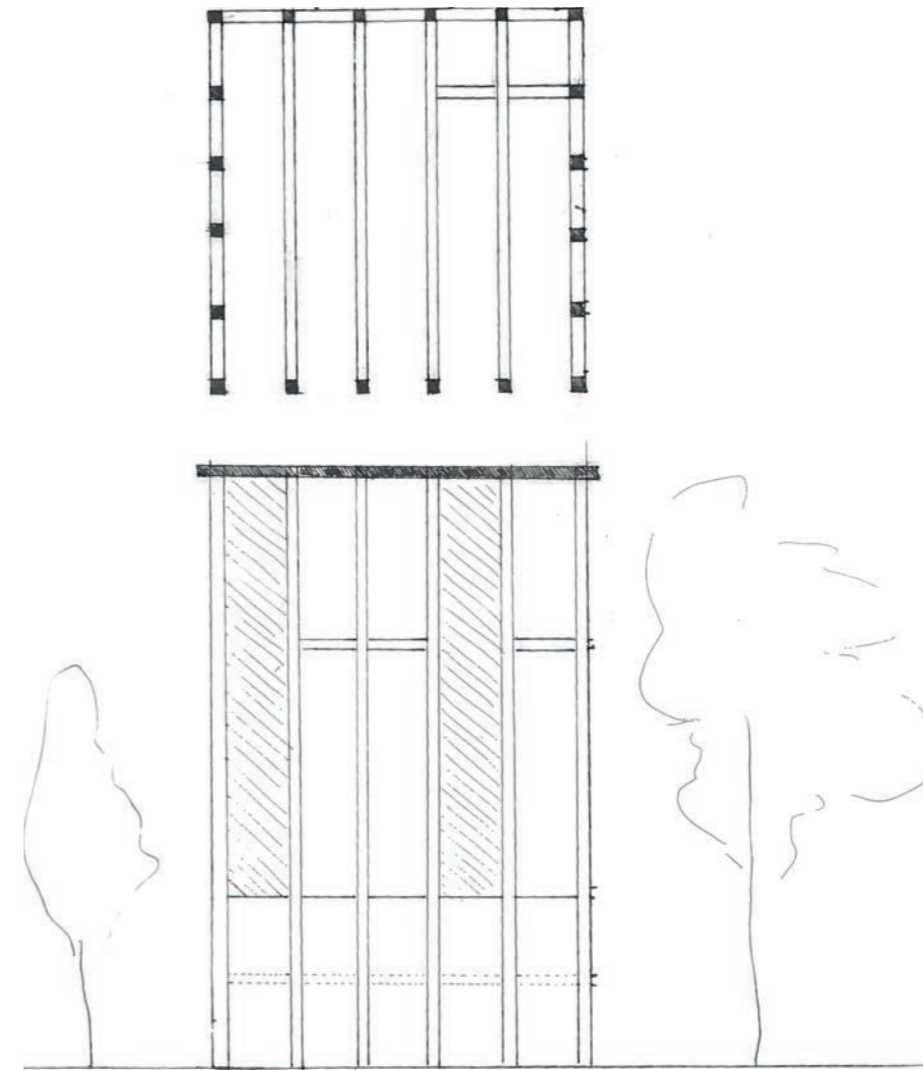

FACADE MODEL OF THE SQUARED SILO

To see what the façade with the vertical structure and big windows would look like, we made several models.



REFLECTING THE INSIDE ON THE OUTSIDE

We wanted to express the concept of the interior wave on the outside of the round silos as well, by positioning the windows in a wave formation.

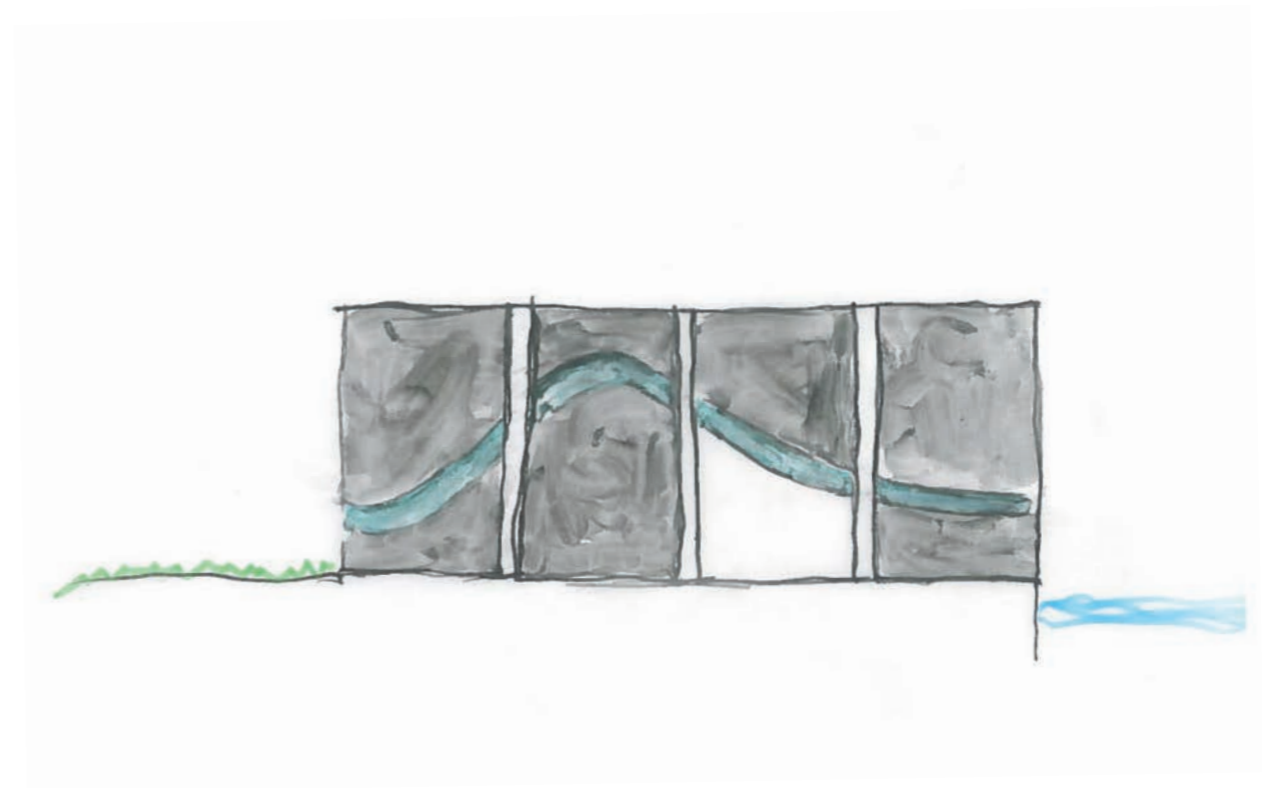

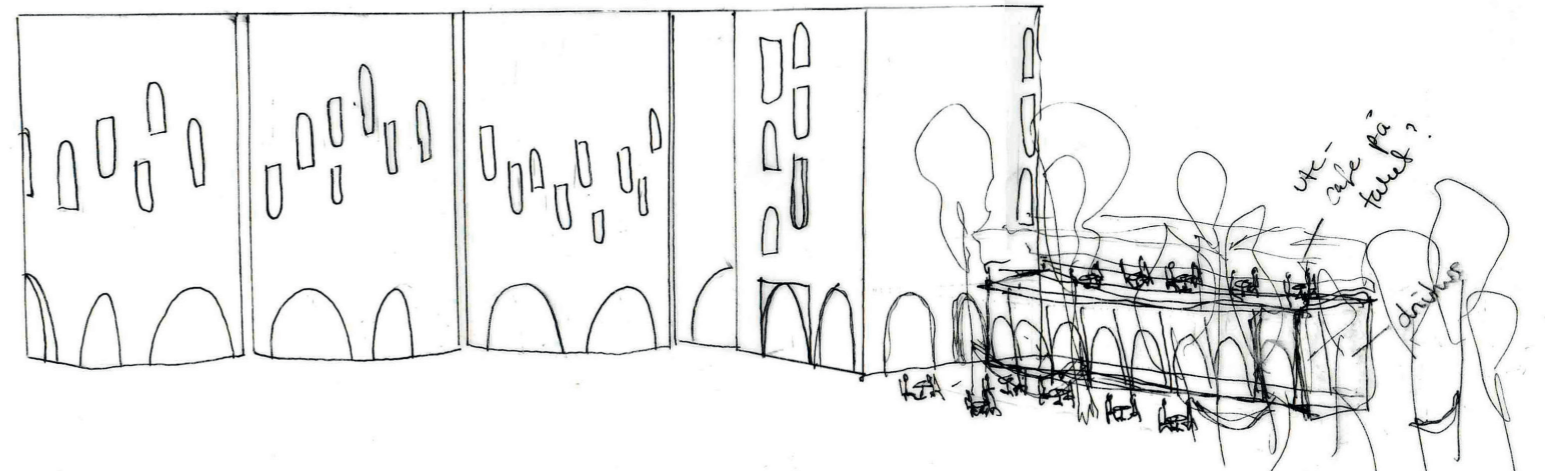

TRYING TO CONNECT THE BUILDINGS WITH THE FAÇADE

The round and the squared silos are perceived as quite different because of their shapes and positioning. We wanted to connect them, and the new building, with a more homogeneous façade.

We made several drawings testing this, but figured out that the shapes of the buildings are so different to start with, that it would be better to embrace this and make the façades different.

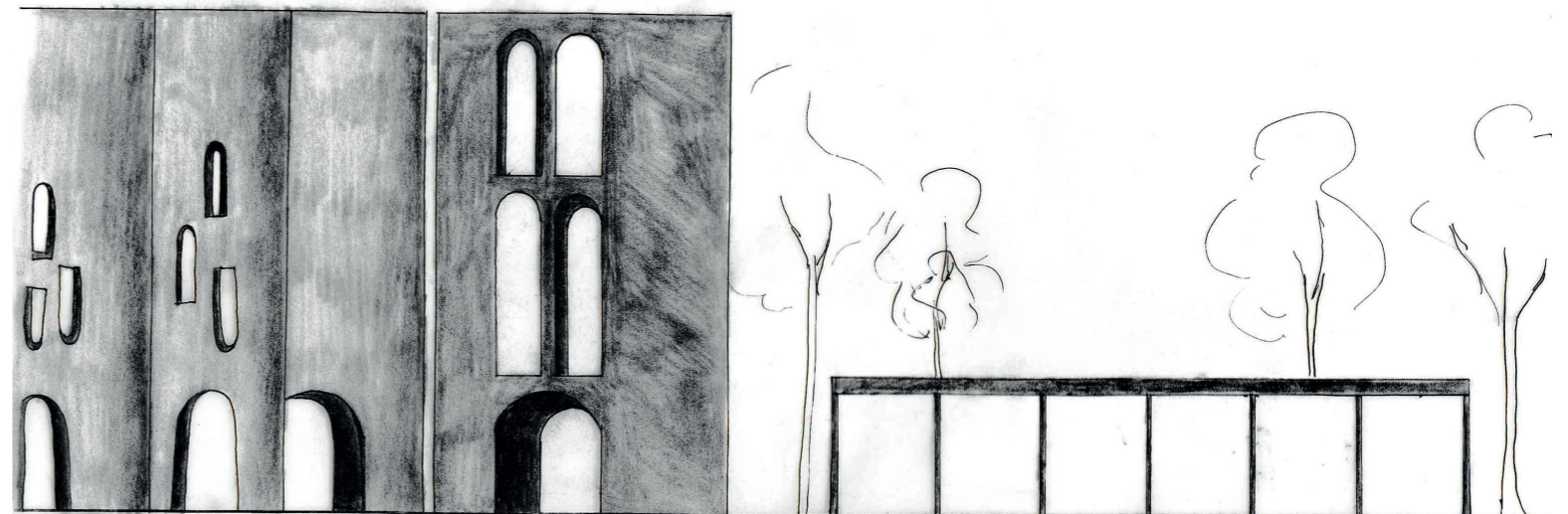
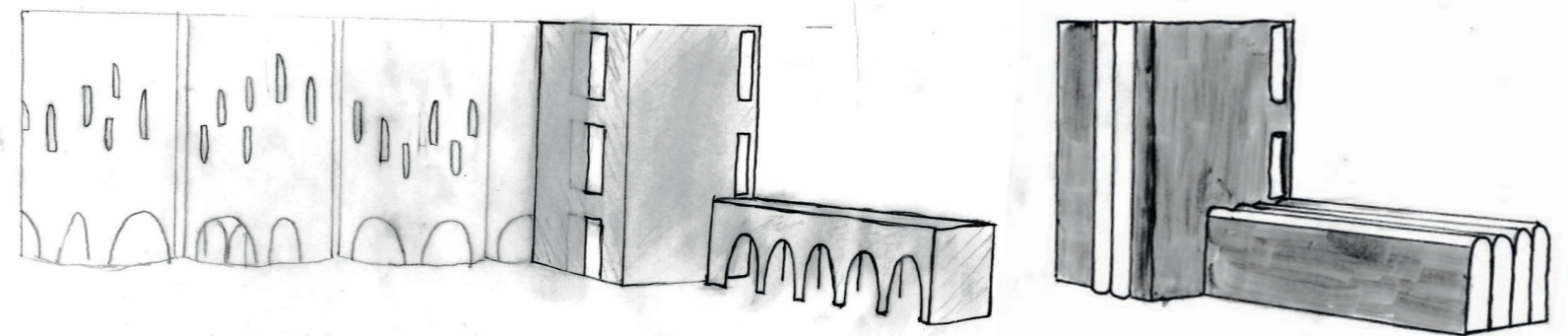

USING PREFABRICATED FACADE ELEMENTS

We decided to add insulation and a new façade on the outside of the silos. To make the added walls as thin as possible we wanted to use fibre-reinforced façade elements made out of concrete. These could have different colours, sizes and be put together in different patterns. These are some tests done to see how this could look.

We also cast some material samples of concrete, testing different colours and patterns.

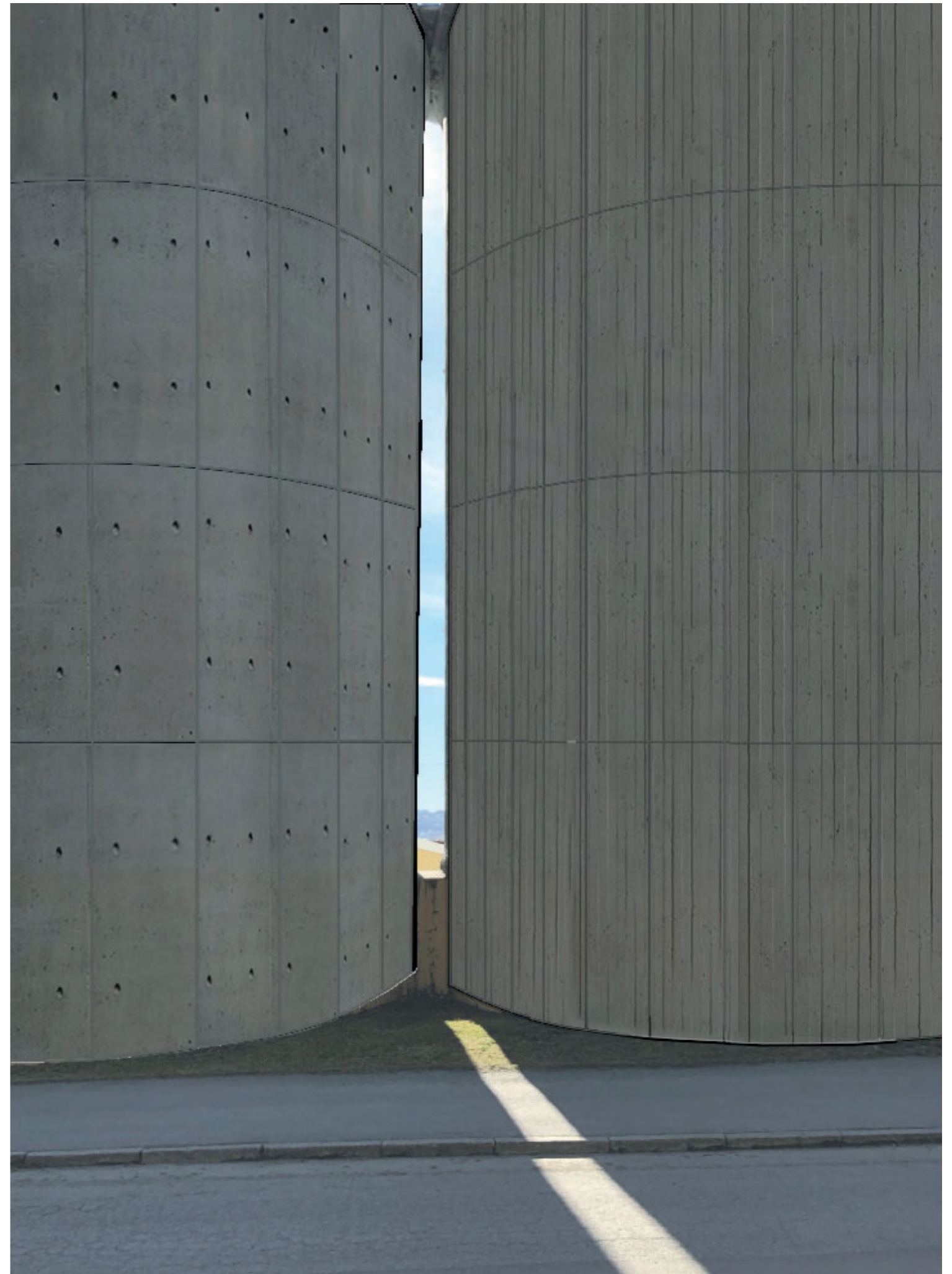

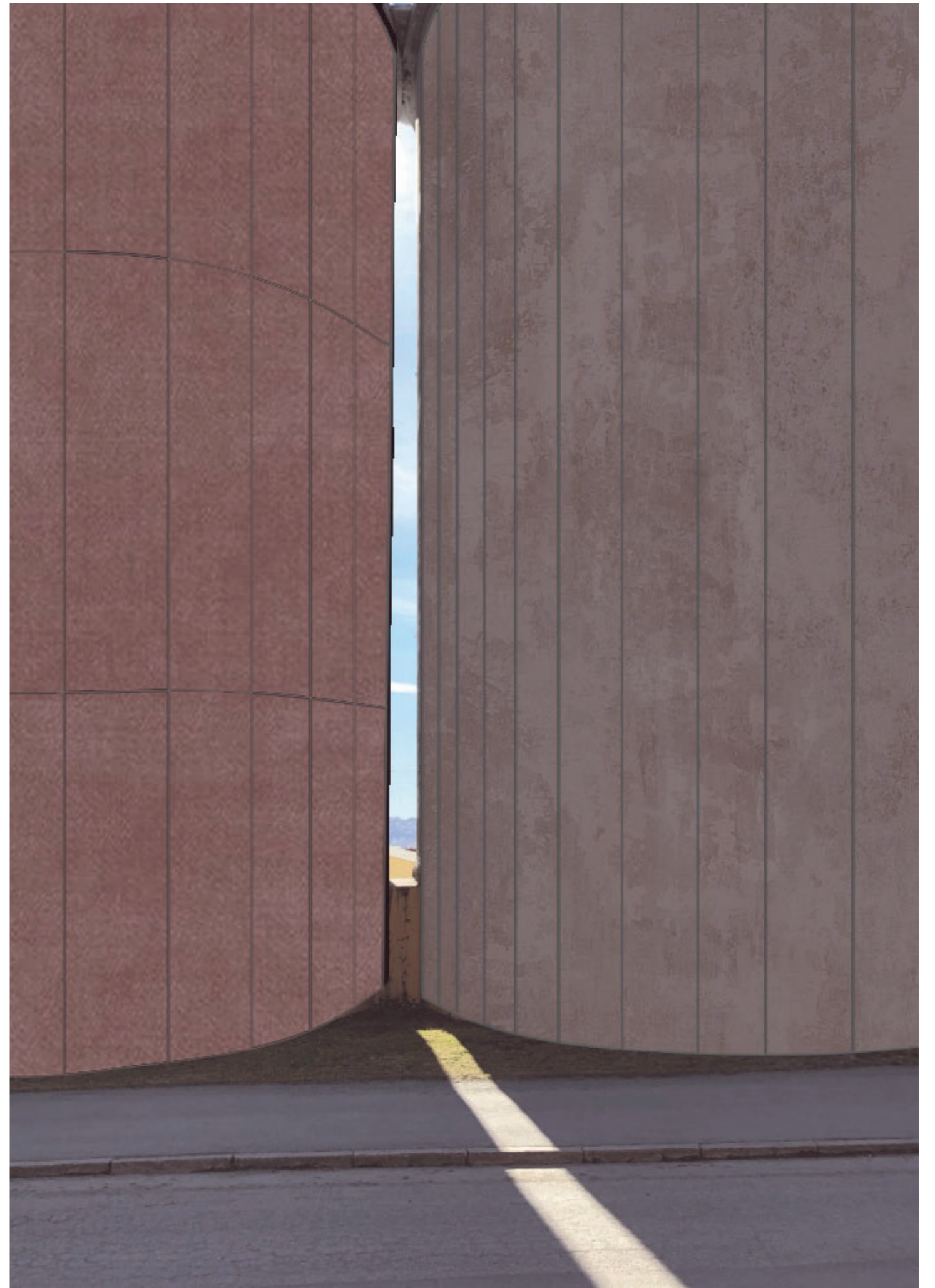

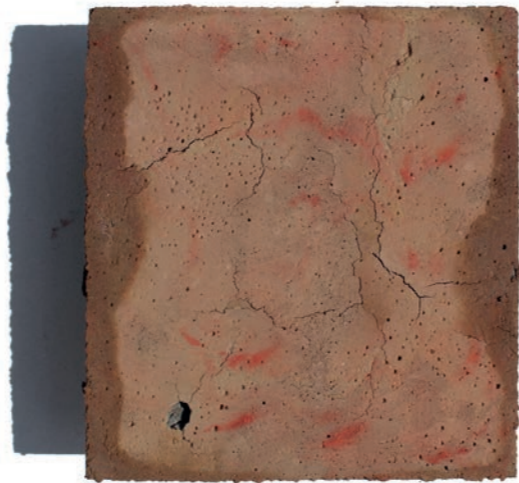

THE SURROUNDINGS

THE ENTRANCE

At first we put the main entrance on both sides of the round silos, in between the two middle ones. You could see this entrance from the road and from the harbour promenade in the south. It turned out to be a problematic solution because it was difficult to see and it was not spacious enough.

We moved the entrance to the round silo closest to the squared silo. You would now be able to see the entrance more clearly, but it did not have a clear connection to the new building.

Eventually we moved the entrance to the squared silo. This was because the squared silo stands out and it allows the staircase in the round silo to be placed more freely. It also improves the connection between the new building and the round silos.

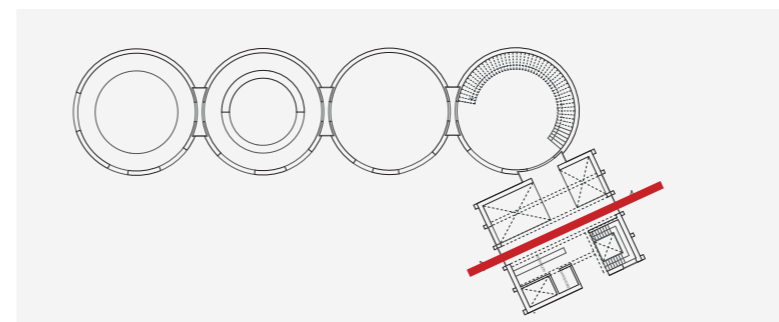
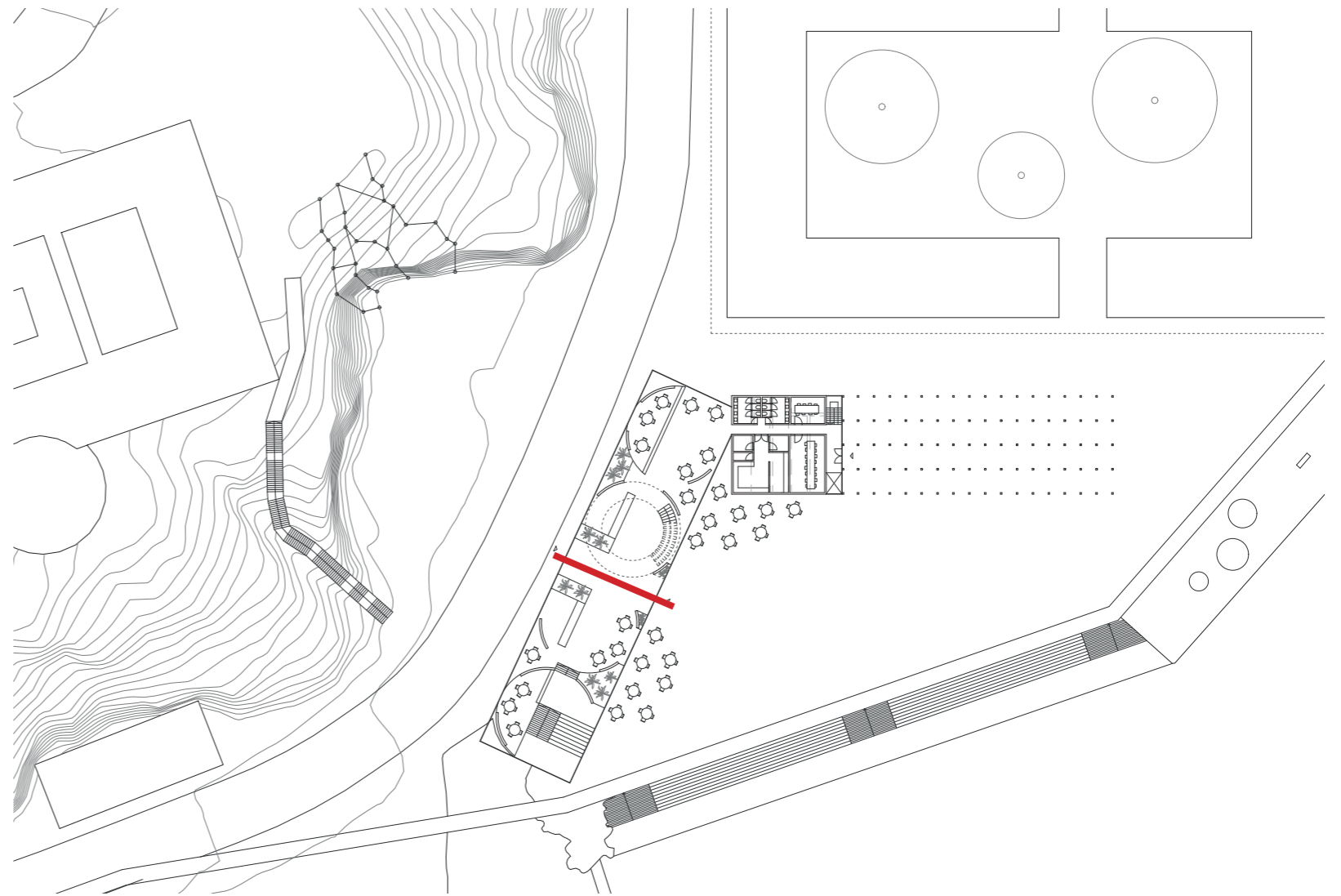

KEEPING THE ORIGINAL STRUCTURE

After making a completely new structure, we saw the potential in keeping the old structure inside of the storage hall. The structure consists of a concrete fundament and green steel frames.

The fundament could be a good base for a skating park. Although we liked the thought of an open park, we felt that the structure did not enclose the space in front of it as we wanted it to. We later found out that we needed more indoor space to make the program in the round silos work properly.

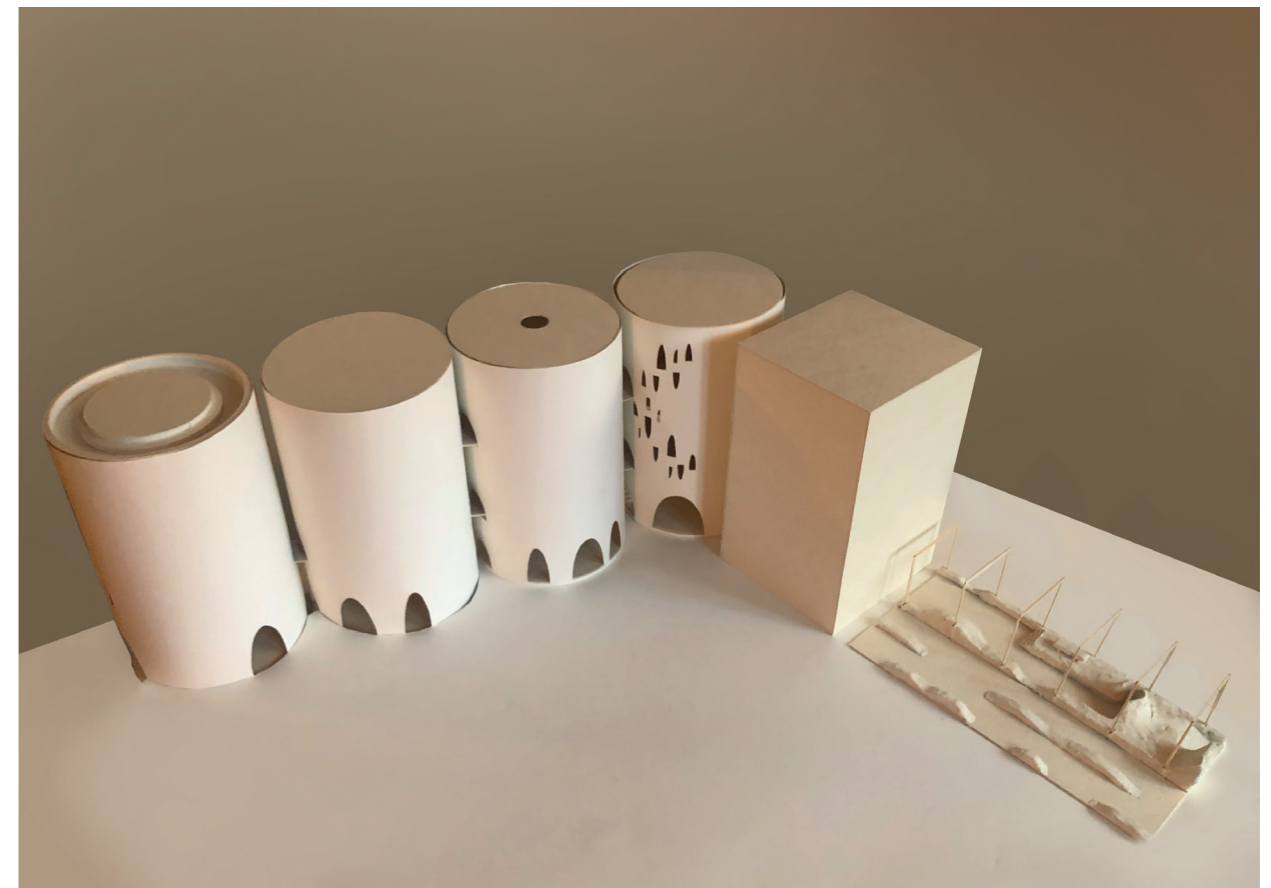
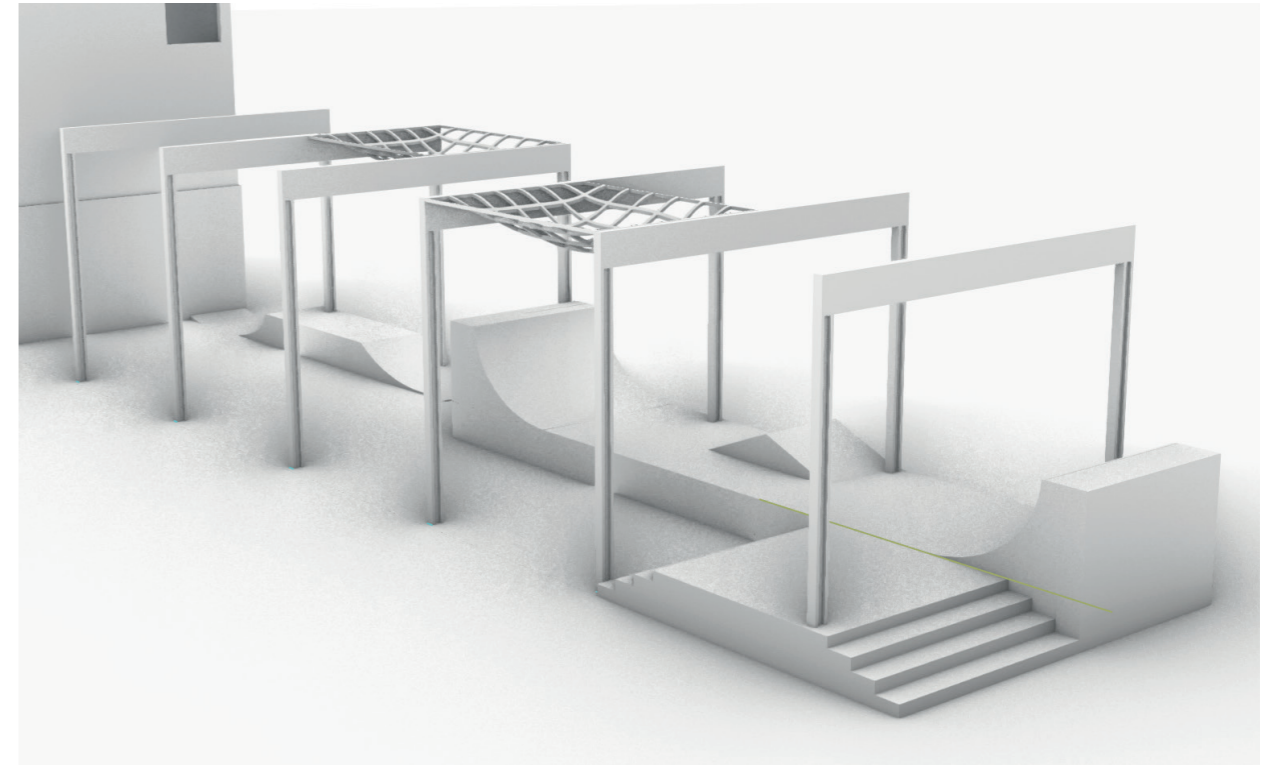

REUSING THE STRUCTURE

We needed more space and therefore decided to make a new building connected to the existing ones. We still wanted to keep the structure that is inside the storage hall today. We decided to put glass between the steel frames and a new storey on top of it.

The new building felt unconnected to the rest and created too much shade in front of it.

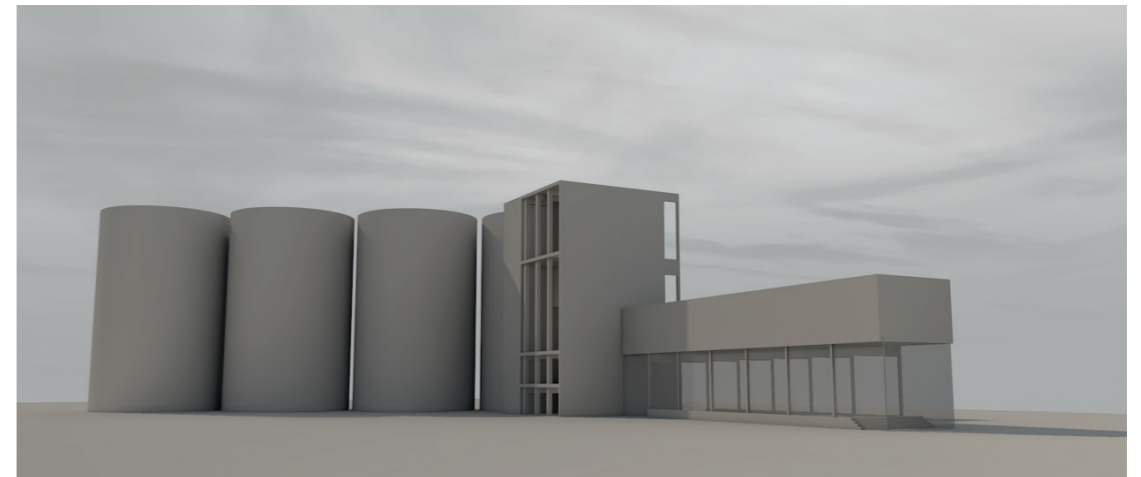
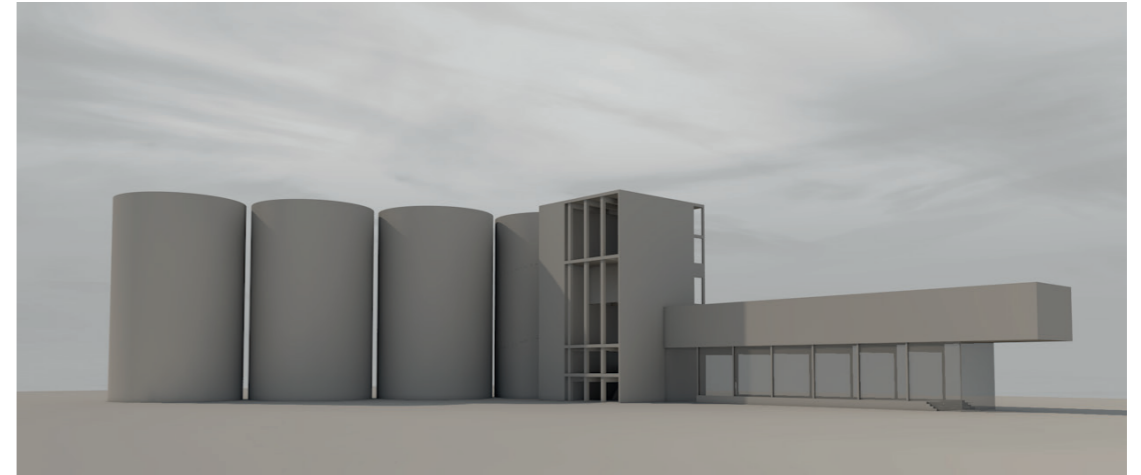

THE DIFFERENT POSSIBILITIES OF THE NEW BUILDING

After figuring out that the storey on top of the glass box was not to our liking, we decided to do further experiments on the shape and positioning of the new building.

We decided that the new building should be disconnected from the silo complex, to clarify that it is a later addition and that it can be used independently.

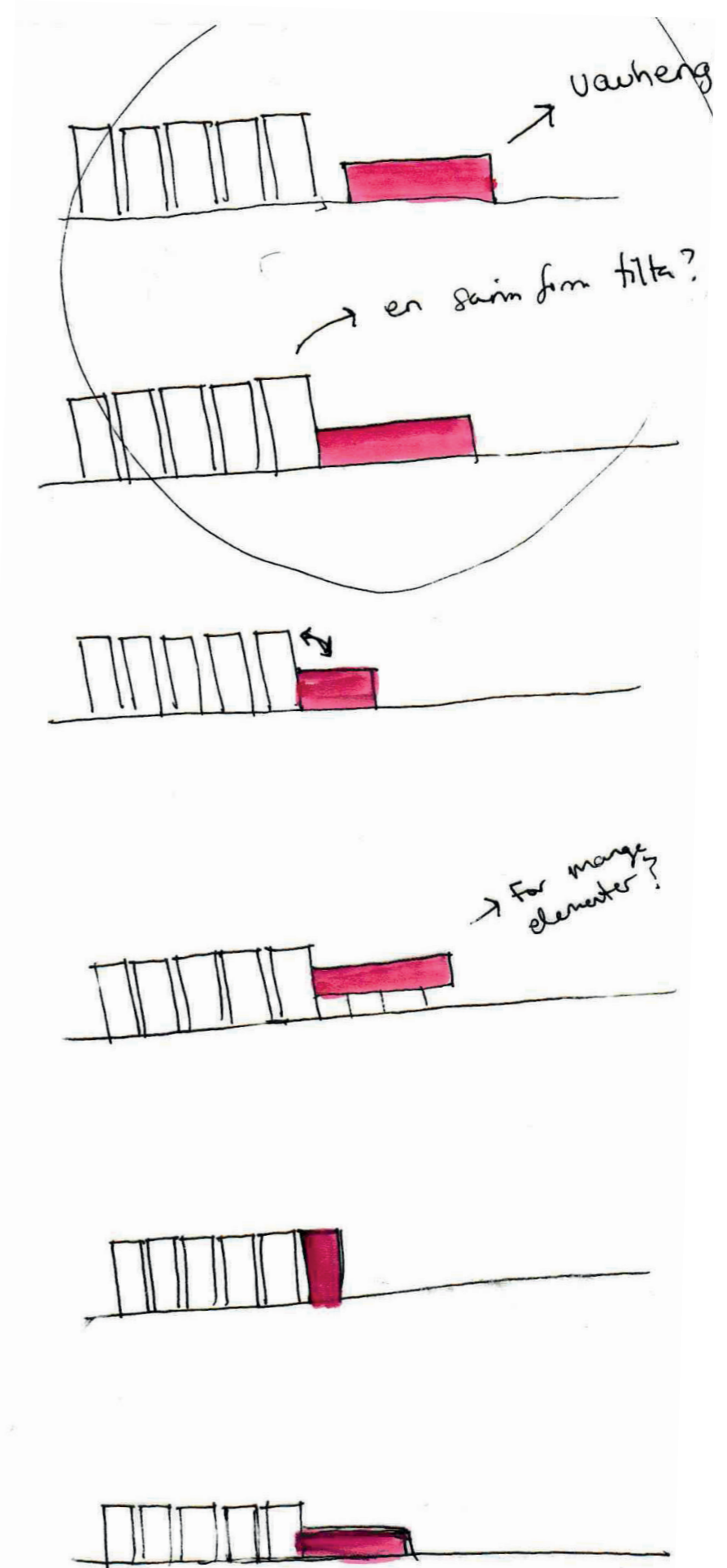

THE PROGRAM

TESTING DIFFERENT PROGRAMS

To begin with, we tested several types of programs, like apartments, a climbing hall, a bath, a cultural school and so on.

We divided the silos into smaller rooms and found out that it did not work well. We then decided that the spaces in the round silos should be as open as possible, to be able to experience the whole circular room. To make this possible we had to create a more flexible program that allowed for this use.

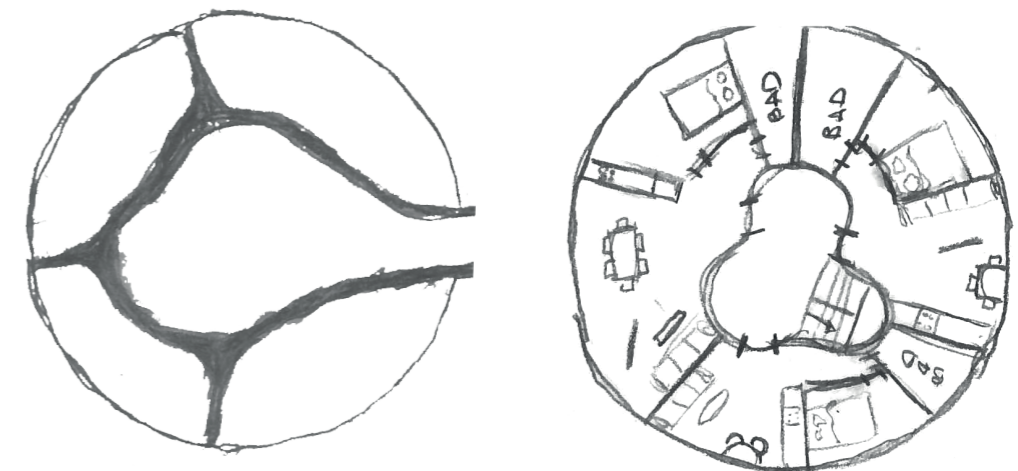
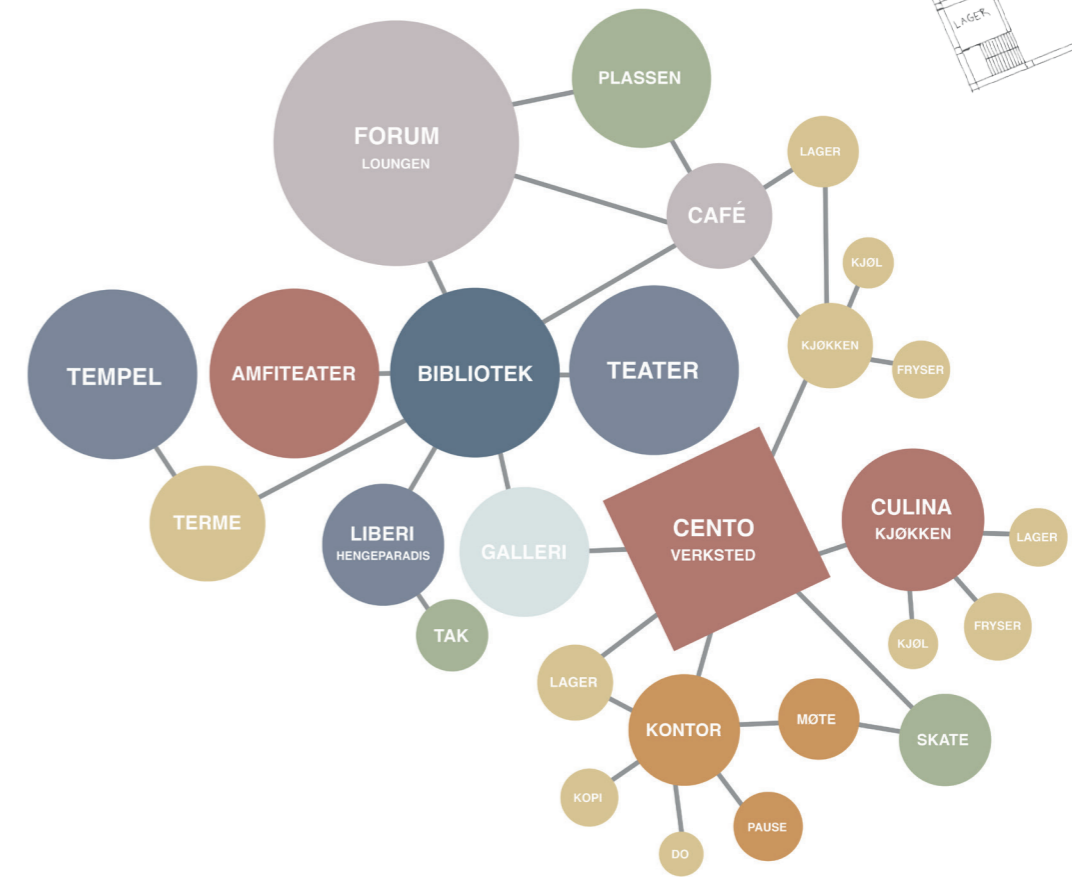
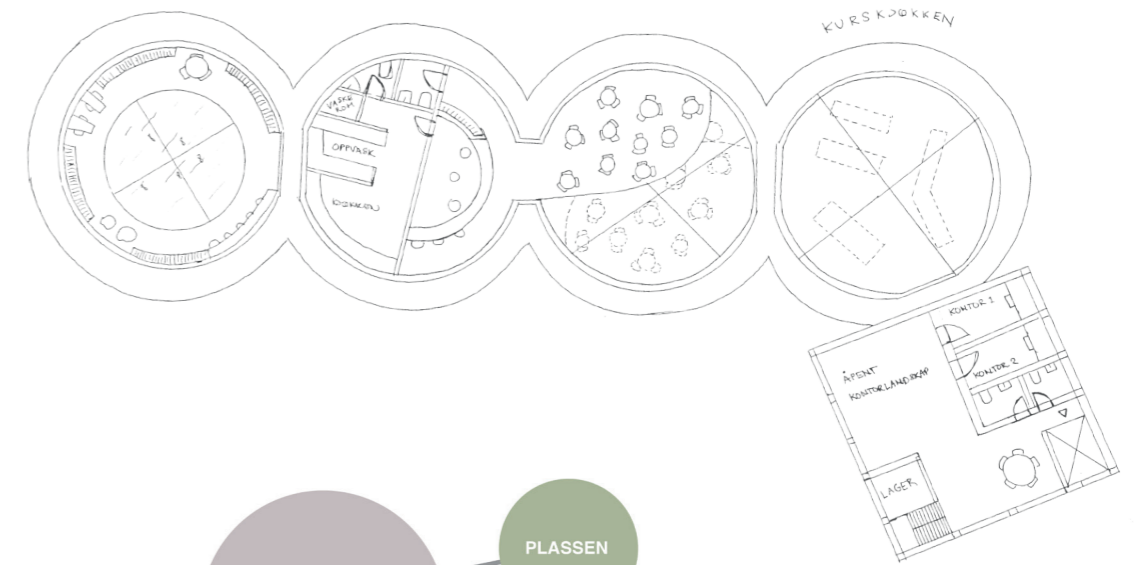

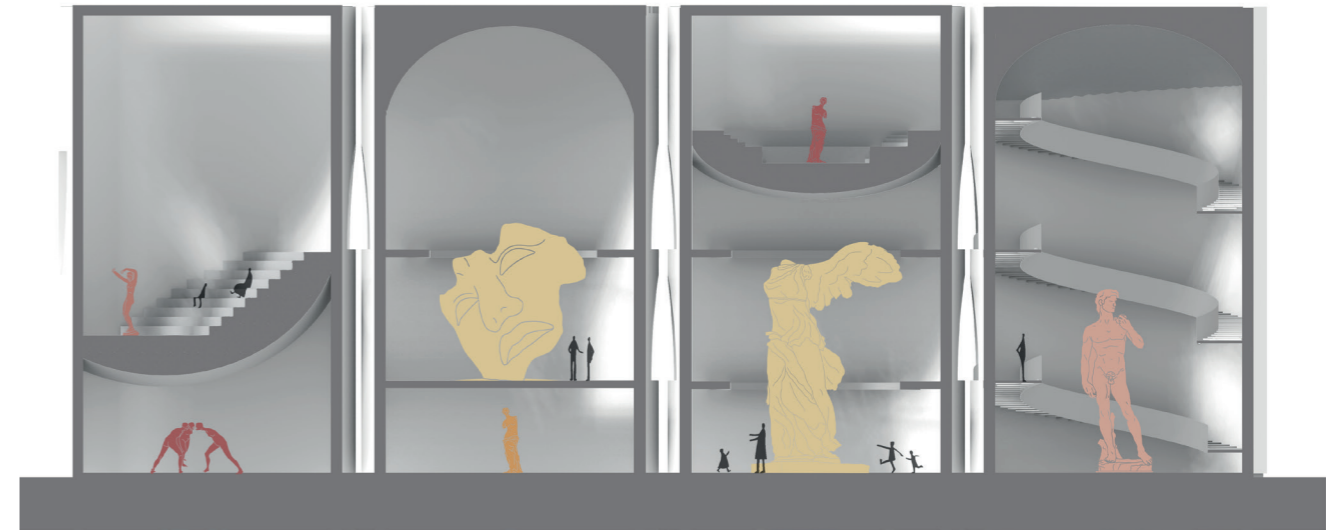

THE FLEXIBLE SPACE

The new idea for the program was to make flexible spaces that could be suitable for different events. The concept was to have a permanent program, but that the buildings could be rented out for periods of time.

It could include an Egyptian museum, a library, an art center or a festival.

We decided that we should move all the technical rooms and smaller rooms to the squared silo because it is more suitable.



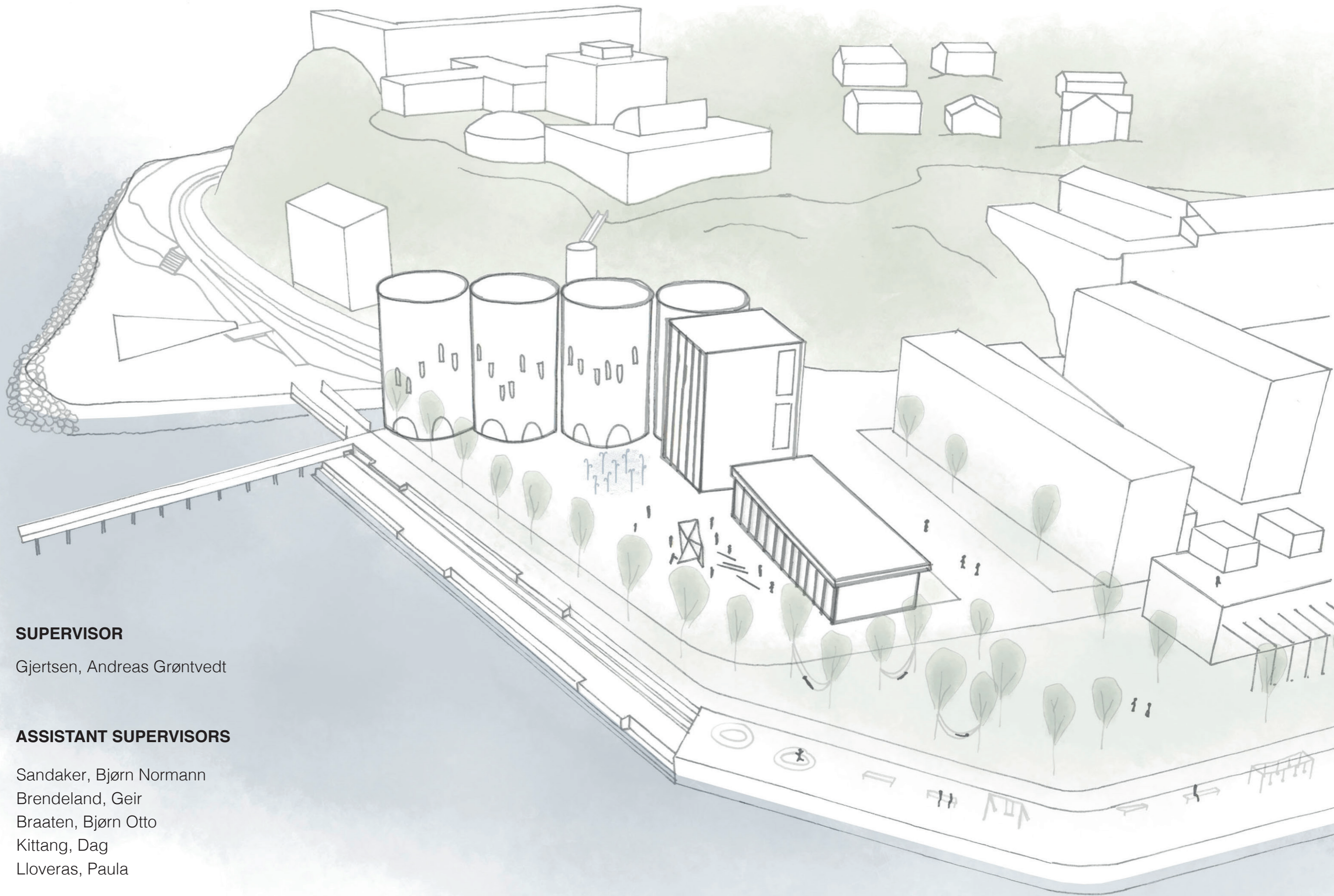

SUPERVISOR

Gjertsen, Andreas Grøntvedt

ASSISTANT SUPERVISORS

Sandaker, Bjørn Normann

Brendeland, Geir

Braaten, Bjørn Otto

Kittang, Dag

Lloveras, Paula