

Cajsa Ryrfors Wien

# Nature-based solution retrofit in an urban catchment for CSO reduction

Master's thesis in Civil and Environmental Engineering

Supervisor: Tone Merete Muthanna

June 2023



Cajsa Ryrfors Wien

# **Nature-based solution retrofit in an urban catchment for CSO reduction**

Master's thesis in Civil and Environmental Engineering  
Supervisor: Tone Merete Muthanna  
June 2023

Norwegian University of Science and Technology  
Faculty of Engineering  
Department of Civil and Environmental Engineering





## Acknowledgments

This thesis is the final product of my education in the master's program Civil and Environmental Engineering at the Norwegian University of Science and Technology (NTNU), Department of Civil and Environmental Engineering. The thesis is written in the format of a report and is my contribution to the field of stormwater management in urban catchments. I hope my will thesis help to further expand the knowledge in the field and that it will inspire future research and motivate the implementation of nature-based solutions to reduce our environmental impact. I would like to thank my supervisor, Professor Tone Merete Muthanna, for guidance, interesting discussions, and support. I would also like to share my appreciation with:

- Ph.D. Birgitte Gisvold Johannesen at Trondheim Municipality for providing information and guidance regarding the project area and the combined sewer overflow.
- Ph.D. Vincent Pons for providing the precipitation data and excellent help with programming.
- Ph.D. candidate Elhadi Mohsen Hassan Abdalla for the great help with the SWMM model and its calibration.
- Postdoc Bardia Roghani, who kindly reviewed and gave feedback on the thesis.

This thesis marks the end of my time as a student. I would like to thank the student organization H.M. Aarhønen for giving me friendships and memories I will carry with me throughout my life. Thank you to my fellow students at the master's office at Valgrinda for conversations both on and off-topic and the fun work environment. A special thanks to my friends and family for their support through five years of ups and downs at NTNU.

Trondheim, June 14, 2023

*Cajsa Ryrfors Wien*

---

Cajsa Ryrfors Wien

## Abstract

Reduced water quality in water bodies connected to urban drainage systems is a pressing issue. Therefore, and due to more extreme weather caused by climate change, the subject of sustainable stormwater management as mitigation against the discharge of volumes of untreated water has gained international attention. Recognizing the urgency, the European Union has launched the project StopUP, which aims to improve the protection of exposed water bodies. NTNU is one of the partners in StopUP, and this thesis is written as preliminary work for NTNU's contribution to the project.

The objective of the study was to evaluate the impact of implementing sustainable urban drainage systems as step 1 solutions for volume and frequency reduction on combined sewer overflows. The study focused on a traditionally developed urban area in the Lademoen district in Trondheim, Norway. The project area was chosen as a potential contribution to the municipal plan for water (VA-plan) and due to the municipality's goal for social development in the area (La'mosatsinga). A SWMM model for the project area was built and calibrated to conduct the analysis, and the simulated results were corrected using optimized correction factors due to challenging calibration results.

The implementation of bioretention cells was found to reduce both the frequency of overflow events and the volume of untreated water discharged to the recipient. This reduction applied not only to the current precipitation pattern but also to the projected future precipitation. The bioretention cells reduced the volume of water entering the combined sewer system, thereby shortening the duration of overflows. However, it was observed that the area theoretically available for the implementation of bioretention cells in the project area was insufficient to manage the anticipated load from the future design precipitation events.

Consequently, it is essential to prioritize and consider innovative solutions concerning urban spaces. Additionally, hybrid systems should be explored to account for the expected increase in CSO events during the winter season, when nature-based solutions are inaccessible.

---

**Keywords** – Three-step strategy for stormwater management, Nature-Based Solutions, SWMM, CSO reduction, Calibration

## Sammendrag

Redusert vannkvalitet i vannforekomster knyttet til urbane avløpssystemer er et økende problem. I kombinasjon med mer ekstremvær som følge and klimaendringer, har bærekraftig håndtering av overvann fått internasjonal oppmerksomhet. Den Europeiske Union (EU) har anerkjent problemet og har som respons lansert prosjektet StopUP, som har som mål å sikre eksponerte vannforekomster mot forurensning. NTNU er en av flere universiteter som tar del i prosjektet, og denne oppgaven er skrevet som del av innledende arbeid til NTNU sitt bidrag.

Målet med denne studien var å evaluere effekten av å implementere lokale overvannshåndtering som trinn 1 løsninger på overløp fra fellessystemer for avløpsvann og overvann. Et område i Lademoen bydel i Trondheim ble valgt som prosjektområde som mulig bidrag til kommunens VA-plan og på grunn av kommunens satsning på områdets sosiale utvikling (La'mosatsinga). For å gjennomføre analysen ble det bygget og kalibrert en SWMM-modell for prosjektområdet. Resultatene ble korrigert ved hjelp av korreksjonsfaktorer grunnet utfordrende kalibrerings-resultater.

Implementering av regnbed viste seg å redusere både frekvensen av overløpshendelser og volumet ubehandlet avløpsvann som ble sluppet ut i resipienten. Reduksjonen gjaldt ikke kun for dagens nedbørsmønster, men også for nedbøren vi kan forvente i fremtiden. Regnbedene reduserte volumet overvann som entret fellessystemet, og forkortet dermed varigheten til overløpshendelser. Imidlertid viser resultatene at det teoretisk tilgjengelige arealet for implementering av grønne løsninger i prosjektområdet var utilstrekkelig for å håndtere den forventede belastningen for avrenning fra fremtidige dimensjonerende nedbørshendelser.

Derfor er det essensielt å utforske og prioritere innovative løsninger for overvannshåndtering i urbane områder. I tillegg bør hybride systemer, med både grønne og grå løsninger, vurderes for å håndtere den forventede økningen i overløpshendelser fra fellessystemer i vintersesongen, når naturbaserte løsninger er utilgjengelige.

# Contents

Acknowledgments.....	I
Abstract.....	II
Sammendrag .....	III
Contents .....	IV
Figures .....	VI
Tables.....	VI
List of Abbreviations .....	VII
1. Introduction.....	1
1.1. Motivation.....	1
1.2. Background.....	1
1.2.1 StopUP.....	1
1.2.1 La' mosatsinga .....	2
1.2.2 Møllenberg Sewage Zone .....	3
1.2.3 VA-norm Trondheim Municipality.....	3
1.2.4 VA-blad.....	4
1.3. Sustainable Strategies for Stormwater Management .....	4
1.3.1 What is a Nature-Based Solution? .....	4
1.3.2 Three-step Strategy for Sustainable Urban Drainage Systems .....	5
1.3.3 Infiltration-Based SUDSs .....	6
1.4. Objectives .....	7
2. Method.....	8
2.1. Selection of project area and land use analysis.....	8
2.2. Project area site description .....	8
2.3. Data Collection .....	9
2.3.1 Precipitation Data.....	9
2.3.2 Operational data from and geometry of OF07 Biskop Grimkjells gate CSO .....	12
2.3.3 Data used in GIS .....	13
2.4. Modeling application .....	13
2.4.1 Area included in the model .....	14
2.4.2 Calibration of the SWMM model .....	15
2.4.3 Validation of the SWMM model .....	17
2.4.4 Area calculations.....	17
2.4.5 Implementation of SUDS in SWMM.....	18
2.4.6 Running SWMM simulations .....	19
2.5. Data Analysis.....	20
2.5.1 Correction factors for simulated water levels .....	20



2.5.2	Depth duration curves .....	20
2.5.3	Frequency and volume analysis .....	21
2.5.4	Seasonal variation .....	22
2.5.5	Design precipitation event and bioretention cell area calculation.....	22
3.	Results.....	25
3.1.	Area calculations.....	25
3.2.	Calibration results .....	25
3.3.	Validation results .....	26
3.4.	Results of optimalization of correction factors .....	27
3.5.	Frequency and volume analysis .....	29
3.5.1	Historical frequencies and volumes .....	29
3.5.2	Frequency and volume in the future .....	29
3.6.	Activation frequency using depth duration curves.....	30
3.6.1	Historical depth duration curve.....	30
3.6.1	Future depth duration curve .....	31
3.7.	Needed surface are of bioretention cell.....	32
3.8.	Seasonal variation .....	33
3.9.	Volume entering the combined sewer system.....	34
4.	Discussion.....	35
4.1.	Calibration and correction factors.....	35
4.2.	Using future climate-modeled precipitation data.....	36
4.3.	Effects of future precipitation on CSO operation and its risks .....	37
4.1.	Retrofit of the urban catchment at Lademoen.....	38
4.2.	The role of step 1 solutions .....	38
5.	Conclusion .....	40
	References.....	41
	Appendix.....	43
A1	Geometry of OF07 Biskop Grimkjells gate .....	43
A2	Pictures from OF07 Biskop Grimkjells gate.....	44
A3	Calibration of the SWMM model using Python (Code) .....	45
A4	Running the SWMM model using Python (Code).....	49
A5	Optimalization of correction factors (Code) .....	51
A6	Design precipitation for step 1 solutions (Code).....	54
A7	Project Thesis of Fall 2022 .....	54

## Figures

Figure 1: Investment area Lademoen, as well as districts Møllenberg and Midtbyen..	2
Figure 2: Three-step strategy for sustainable urban drainage systems..	5
Figure 3: Typical design of a bioretention cell/ raingarden in Norway.....	6
Figure 4: Buildings of heritage interest in the project area .....	9
Figure 5: Historical precipitation (2015 – November 2022) .....	10
Figure 6: Variation of the future climate-modelled precipitation timeseries cumulative. ....	12
Figure 7: Sub-catchments in the project area draining to OF07. OF07 is marked in blue. ....	14
Figure 8: All sub-catchments which drain to OF07 included in SWMM. ....	14
Figure 9: Precipitation event used for calibration of the SWMM model. ....	17
Figure 10: Pipe L190252 (red) leading into OF07 (blue) for reduction calculation .....	22
Figure 11: Precipitation, observe,d and simulated water levels with parameter set 1 and 2. ....	26
Figure 12: Simulation results for validation run 5 for parameter set 1 and 2. ....	27
Figure 13: Effect of correction factors C1 and C2 on water levels validation run 5. ....	28
Figure 14: Boxplot displaying the variation in water levels for validation run 5. ....	30
Figure 15: Depth duration curve for historical timeseries scenario 1 and 2. ....	31
Figure 16: Depth duration curve for future 5-year periods scenario 1 and 2. ....	32
Figure 17: Seasonal distribution in CSO activation. ....	33

## Tables

Table 1: Climate models for future precipitation timeseries. RCP8.5.....	10
Table 2: Modell parameters and bounds for calibration.....	15
Table 3: Periods of timeseries used in validation. ....	17
Table 4: Parameter values and their sources for the bio-retention cell module in SWMM. ....	19
Table 5: Calibration results for the calibration run 1 and 2.....	25
Table 6: NSE-results from validation runs 1 to 5 for parameter set 1 and 2. ....	27
Table 7: Optimized parameters and correction factors.....	28
Table 8: Percentage of times of occurrence of water levels for CSO activation 2018-2022.....	31
Table 9: Percentage of times of occurrence of water levels for CSO activation in the future ...	32
Table 10: Design precipitation and BRC area needed.....	33

## List of Abbreviations

<i>BRC</i>	Bioretention Cell
<i>C1</i>	Correction factor 1, optimized to replicate days with CSO
<i>C2</i>	Correction factor 2, optimized to replicate number of timesteps with CSO
<i>CSO</i>	Combined Sewer Overflows
<i>DWF</i>	Dry Weather Flow
<i>hr</i>	Hour
<i>k1</i>	Optimized parameter 1 (1 / C1)
<i>k2</i>	Optimized parameter 2 (1/C2)
<i>KGE</i>	Kling-Gupta Efficiency, goodness-of-fit function
<i>km</i>	Kilometer
<i>LID</i>	Low Impact Development
<i>m</i>	Meter
<i>m<sup>2</sup></i>	Square meter
<i>m<sup>3</sup></i>	Cubic meter
<i>masl</i>	Meters Above Sea Level
<i>mm</i>	Millimeter
<i>MSE</i>	Mean Square Error, goodness-of-fit function
<i>n</i>	Manning's roughness coefficient
<i>NaN</i>	Not A Number
<i>NBS</i>	Nature Based Solutions
<i>NSE</i>	Nash-Sutcliffe Efficiency, goodness-of-fit function
<i>OF07</i>	Combined Sewer Overflow (Overløp Felles) Biskop Grimkjells gate
<i>P<sub>design</sub></i>	Design precipitation
<i>P1</i>	Parameter set 1
<i>P2</i>	Parameter set 2
<i>PA31</i>	Pumping Station Ormen Langes veg
<i>PE</i>	Person Equivalents
<i>R<sup>2</sup></i>	R <sup>2</sup> , goodness-of-fit function
<i>RCP8.5</i>	Representative Concentration Pathway for radiative forcing of 8.5 W/m <sup>2</sup>
<i>RMSE</i>	Root Mean Square Error, objective function
<i>s</i>	Seconds
<i>S1</i>	Scenario 1, "do-nothing" scenario
<i>S2</i>	Scenario 2, SUDS implemented
<i>SUDS</i>	Sustainable Urban Drainage Systems

# 1. Introduction<sup>1</sup>

## 1.1. Motivation

Due to climate change, the world faces challenges connected to changes in weather patterns. In the case of Trondheim, this will be projected as wetter and more extreme weather conditions (Klimaservicesenter, 2022). Precipitation with higher intensities results in runoff that can exceed the capacity of combined sewers and conventional separate systems for wastewater and stormwater. Such discharges contain pollutants from pharmaceuticals, personal care products, and chemicals from products for household management (Rosenfeld & Feng, 2011). Additionally, there is a high level of biological microorganisms transported with the wastewater, which can lead to infections if in contact with humans or animals. As a consequence, there is an urgent need for sustainable solutions in urban stormwater management to protect both human well-being and the environment.

Trondheim municipality operates an extensive sewer network spanning 1400 km, with 335 km being combined sewers. This does not include the private pipes (Trondheim Municipality, 2022a). Presently, the system is designed for storm events with 20-year return period based on historical data from the reference period of 1971 to 2000. However, it is evident that this design standard will no longer be sufficient, as 20-year storm events are expected to occur every five to ten years in the future (Klimaservicesenter, 2023). To address the issue, the municipal plan for 2022-2033 recommends the separation of approximately 60% of the combined sewers. (Trondheim Municipality, 2022).

The public's attachment to the nearby water bodies has intensified, and people want to use their surroundings for recreation. In Trondheim, an increased interest in bathing in the Trondheim Fjord has emerged. This trend can, for instance, be seen in the growing popularity of the sauna and culture center [Havet Arena](#) in Nyhavna. The same trend can be seen in other cities in Norway such as Bergen and Oslo. The shifting culture of coastal cities calls for solutions for reducing the discharge of untreated wastewater to ensure public health.

In addition to the public interest, the European Commission has proposed a new and stricter directive concerning urban water treatment. This directive mandates the reduction of Combined Sewer Overflows (CSOs) and Stormwater Overflows (SWOs) (EU ENV, 2022, art. 5), and highlights that solutions for reducing overflows from urban water must be prioritized.

## 1.2. Background

### 1.2.1 StopUP

As a reaction to the increase in pollution in the water bodies that receive urban runoff, the European Union has initiated a project that aims to develop solutions to protect exposed water bodies. The project's objective is to provide technical solutions, information, tools, and guidance to limit the impact of urban pollution in recipients. The solutions must consider local factors including geography, climate, land use, and receiving water bodies. Financed by the European Union, the project is scheduled to run for a duration of 36 months, starting September 1<sup>st</sup> 2022. (RWTH, 2022)

---

<sup>1</sup> Sections 1.1, 1.2, and 1.3 are based on the project thesis of fall 2022 (Wien, 2022). The information has been adjusted to fit the context of this thesis. The project thesis in its entirety can be found in Appendix A7.

NTNU has been given the work package title “Urban Runoff Management”, which is the fourth out of eleven work packages given to universities, water utilities, consultants, and SMEs in seven European countries and Tunis. The objective of NTNU’s work package is divided into three parts:

1. A guideline for city-wide urban diffuse pollution measurement campaigns – what to measure, how to measure, and where to measure with and without prior knowledge of the system.
2. Decision support tool based on the output from work packages one and three. Development of innovative treatment concepts; how to select the right treatment option; selection of decision criteria for treatment identification needs and water quality performance indicators.
3. Evaluation of the effectiveness of a SUDS (Sustainable Urban Drainage Systems) design using the Water Quality Interception tool.

(StopUP, 2021)

Polluted water from CSOs is one of the main components that must be reduced to improve the water quality of urban water bodies. Separating urban drainage systems from wastewater sewers and implementing SUDSs are solutions that reduce the daily water load in CSOs.

### 1.2.1 La’mosatsinga

This section describes the municipal project La’mosatsinga based on the case presentation provided by Trondheim Municipality (*Saksfremlegg*, 2021).

In 2020, Trondheim Municipality was asked to evaluate new possible investment areas after satisfying results from the investment area “Områdeløft Saupstad-Kolstad”. On March 23<sup>rd</sup>, 2021, Trondheim Municipality elected Lademoen and Tempe-Sorgenfri to be the new areas of investment. The project aims for a holistic effort to equalize social differences between different districts within the municipality. The name of the project in the Lademoen district is La’mosatsiga. La’mosatsinga is, like previous projects, a collaboration between the state, municipality, county government, and the local community.

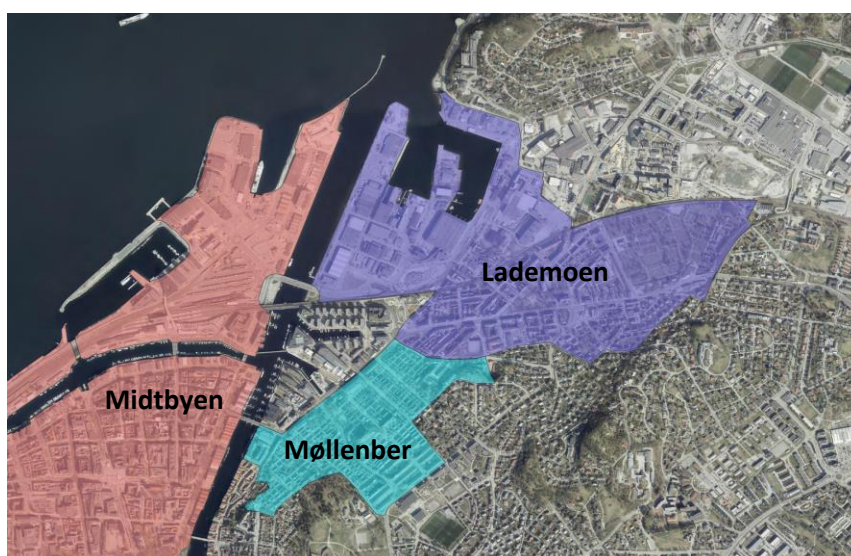

**Figure 1:** Investment area Lademoen, as well as districts Møllenber and Midtbyen. Picture from *Saksfremlegg* (2021).

Lademoen was elected as an investment area based on the challenges in living conditions that have been observed. The investigation of living standards includes the social, economic, and health conditions of the residents.

The case presentation states four issues to consider:

- How can the development of networks and initiatives that bring together diverse groups of citizens be further enhanced?
- In what ways can public services and properties be utilized as platforms and resources to foster strong local communities and dynamic local environments, benefiting children?
- Can effective cultural heritage protection promote social diversity and create appealing living areas while simultaneously contributing to an age-friendly urban environment that accommodates students, immigrants, children, and the elderly?
- How can the development of private and public housing, as well as urban spaces, contribute to more attractive living environments?

This thesis aims to contribute to the second and fourth points of the issues to consider, by implementing nature-based solutions (NBSs). NBSs will safely transport stormwater while simultaneously enhancing the presence of green spaces.

### **1.2.2 Møllenberg Sewage Zone**

Trondheim Municipality is divided into sewage zones. The sewage zone which is relevant for this thesis is the Møllenberg sewage zone, which is defined as the area where the sewage drains to the pumping station PA31 Ormen Langes veg. The information in this section is derived from the remediation plan for sewer zone Møllenberg from 2014. (Trondheim Municipality, 2014)

In 2004, the sewer zone included water from approximately 20200 person equivalents (PE). The system is described as an old, combined sewer system, however, with partial upgrades to separate systems in Nedre Elvehavn, Rosenborg, and Lademoen/Buran. The key issues described in the remediation plan include damaged and old pipes and manholes, insufficient capacity in pipes and CSOs, and the infiltration of seawater into the system. The challenges regarding capacity are assumed to increase due to the expectations of more extreme weather caused by climate change.

In addition, the population in the zone is likely to have grown due to the increase in housing. The residential areas in Dyre Halsesgate, Rosenborg Park, Lilleby, and Øvre Nyhavna have seen the largest growth, with 3152 new residences registered in the period 2004-2023 (S. Eiksund, 2023). How the PE in 2004 was calculated is unknown, and a new estimation of the population for the zone has not been conducted since only a part of the zone is relevant for this thesis.

### **1.2.3 VA-norm Trondheim Municipality**

Each municipality in Norway has a set of standardized rules for how the water systems, sewer systems, and urban drainage systems should be constructed. These are found in the municipal guideline called VA-norm (Vannforsynings- og avløpsnorm). The VA-norm is open for use

and can be found on the website of the municipality or at [va-norm.no](http://va-norm.no), which is provided by [Norsk Vann](#).

The guidelines and rules for stormwater systems in Trondheim Municipality are described in section 7 *Transportation system – Stormwater* of Trondheim Municipality’s VA-norm. It is made clear already in the beginning of the section that the municipality wishes runoff to be managed locally. The VA-norm also states standards for the calculation of stormwater runoff, type and size of pipes, and minimum slope for self-cleanse. There is also information about connecting pipes to the drainage system, standards for manholes and gully pots, as well as requirements for maintenance and replacement. The VA-norm includes little information about solutions for local stormwater; however, refer to [VA-blad No. 92 surface water infiltration](#) and [VA-blad No. 93 open flood paths](#).

#### **1.2.4 VA-blad**

There are multiple VA-blad (water supply and sewer sheets) for stormwater management in Norway. VA-sheets are documents provided by the foundation VA/Miljø-blad with the goal to provide guidelines for water management (Stiftelsen VA/Miljø-blad, 2023). The sheet that is most relevant regarding stormwater solutions is VA-blad [no. 125 Managing stormwater – LID](#). The sheet includes background information about the local management of stormwater, an introduction to the three-step strategy, as well as technical solutions for each step. It is a guideline for municipalities and water management consultants for better local stormwater management. Other VA-sheets that are relevant to the topic of stormwater management can be found by searching for the keyword “overvann” on the website [va-blad.no](http://va-blad.no).

[VA-blad no. 74 Stormwater overflows – selection of solution and design](#) is another sheet that is relevant in the setting of this study. It describes the purpose and design of stormwater overflows, as well as guidelines for maintenance.

### **1.3. Sustainable Strategies for Stormwater Management**

#### **1.3.1 What is a Nature-Based Solution?**

Nature-based solutions (NBSs) are technologies that are inspired by nature and objects to replicate or use natural processes for managing water (Frantzeskaki, 2019). Specifically, NBSs are defined as living solutions that are supported by nature and designed to be cost-effective while delivering social and economic benefits. Simultaneously, they provide environmental benefits and contribute to building resilience. NBSs aim to support natural diversity, natural features and processes in urbanized areas, landscapes, and seascapes through local adaptation and efficient use of resources (European Commission). In this case, NBSs have the purpose of managing stormwater as part of the urban drainage system.

Many different names have been developed under the definition above. The name used differs geographically. For instance, the term SUDS (Sustainable Urban Drainage Systems) is used in the United Kingdom; LID (Low Impact Developments) is used in the USA; WSUDS (Water Sensitive Urban Design) is used in the Middle East and Australia (Wikipedia, 2022); and LOD (Lokal Overvannshåndtering) is used in Norway (Lindholm, 2018). In this thesis, the term SUDS will be used.

### 1.3.2 Three-step Strategy for Sustainable Urban Drainage Systems

The three-step strategy is a strategy developed to minimize the consequences of urban runoff. It aims to be a simple guideline for municipalities and other stakeholders to develop cities and urban areas with SUDS. SUDS have the objective of protecting human safety and health, preventing environmental pollution, and preventing flooding (Tscheikner-Gratl, 2022). This thesis focuses on Step 1 solutions for the project area chosen in the Lademoen district. A visualization of the three-step strategy is shown in Figure 2, with step 0 being the planning of the next three steps.

Step 1 aims to collect, clean, and infiltrate runoff from small precipitation events. The objective is to ensure sustainable water quality and the protection of the local environment. Small precipitation events are considered events with precipitation less than 20 mm (Lindholm, 2018). Examples of Step 1 solutions are bioretention cells and green roofs. These are solutions where surface water is directed to filters instead of directly to pipes.

Step 2 aims to detain and retain runoff where Step 1 solutions are not sufficient. This includes detaining and retaining runoff from large precipitation events through, for instance, green roofs, bioretention cells with higher volume capacities, and/or basins. Large events are considered events with precipitation of 20-40 mm (Lindholm, 2018). The objective is to hold back runoff to ensure that the combined or separated sewer system can manage the water load without the occurrence of overflow. Preventing CSO events or pluvial flooding of manholes is an issue of protecting public health.

Step 3 is the last of the three steps and aims to secure safe flood paths for runoff from extreme runoff events when flood-preventing measures are not sufficient. This includes construction of roads which can function as flood paths, and securing areas at risk of erosion. Extreme events are considered events with precipitation larger than 40 mm or a precipitation event with a 100-year return period (Lindholm, 2018).

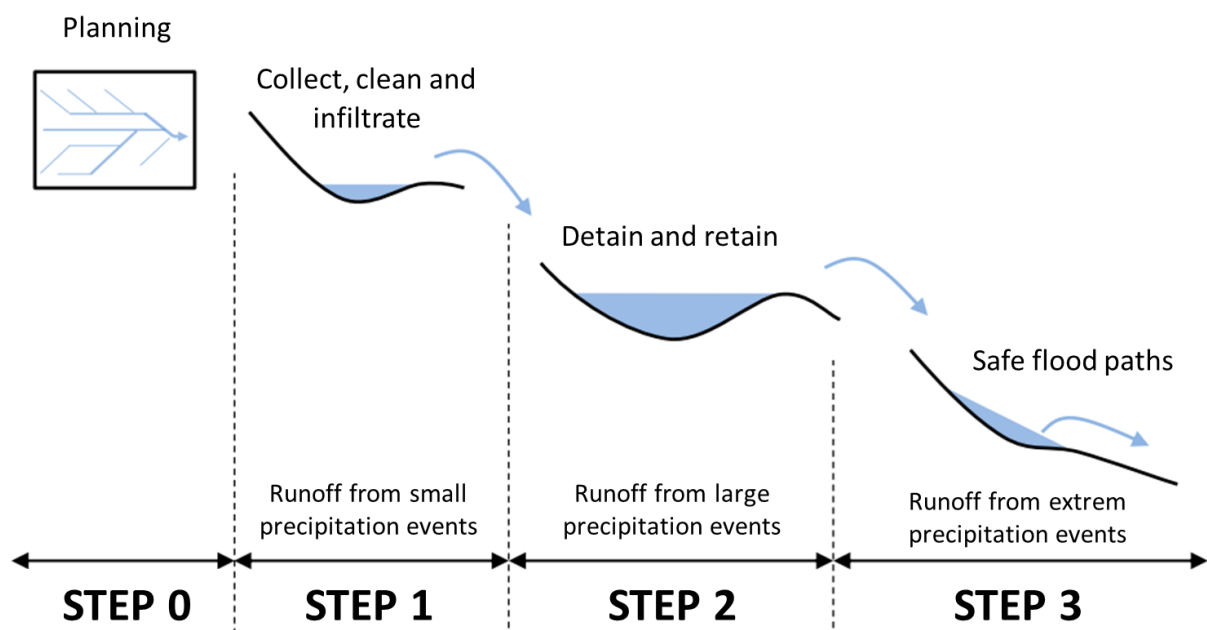

Figure 2: Three-step strategy for sustainable urban drainage systems. Translated to English from Paus (2018).



### 1.3.3 Infiltration-Based SUDS

One of the most popular types of SUDS is infiltration-based solutions. These solutions incorporate filters that consist of a porous filter media, a storage volume for temporary runoff holding and processing, an underdrain system for filtered water, and a bypass or spillway that activates when the filter reaches its capacity (WEF & EWRI (U.S.), 2012). Infiltration solutions can serve multiple objectives, including improving water quality, temporarily storing stormwater to control peak flows (WEF & EWRI (U.S.), 2012), redirecting water through the underdrain system, and infiltrating stormwater to the ground to reduce stormwater volumes. Consequently, infiltration-based solutions can serve as both Step 1 and Step 2 solutions in the three-step strategy.

The function of the filter is dependent on the design of the solution and local factors. For treatment, the total surface area of individual grains in the filter media and the contact time of the water are important to obtain better water quality. For stormwater peak reduction, storage volume is the main driver (WEF & EWRI (U.S.), 2012). Examples of infiltration-based solutions are infiltration trenches, swales, and bioretention systems such as raingardens. Swales and raingardens are examples of vegetated surfaces (Butler et al., 2018, p. 454).

Bioretention Cells (BRCs) intercept runoff from storm events and treat the stormwater, usually through sandy filter media. The treatment of the water is mechanical filtration combined with sedimentation, adsorption, and uptake from plants and microbial activity in the filter media. (Hatt et al., 2009) A typical BRC design can be seen in Figure 3 (Paus et al., 2015). Whether the BRC is suitable for infiltration into the ground is dependent on the properties of the local soil. In the case of Lademoen, the local soil is unclassified (NGU, n.d.), but it is assumed to have similar properties to clay. In this thesis, BRCs are selected as a Step 1 solution for stormwater management.

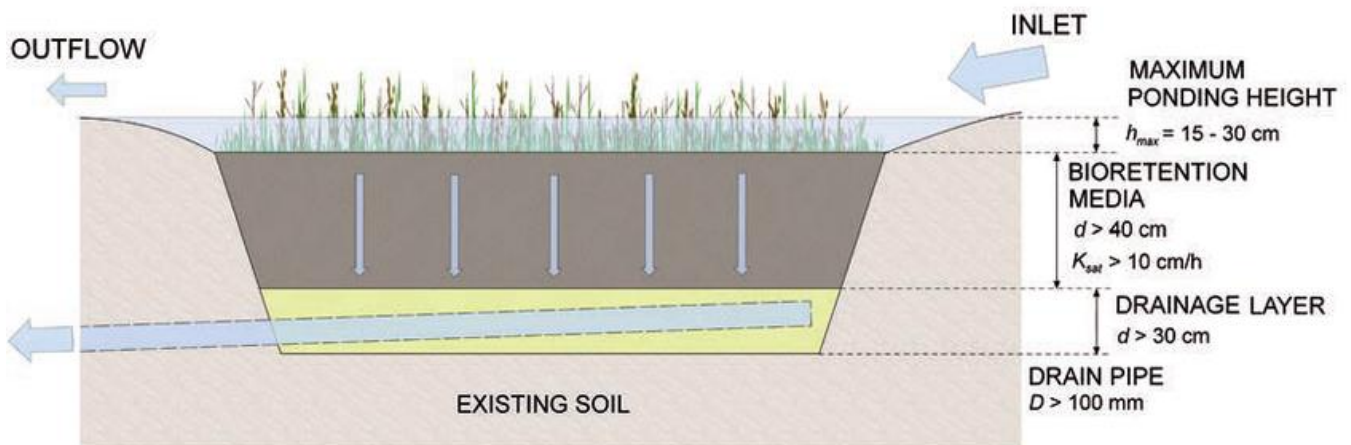

Figure 3: Typical design of a bioretention cell/ raingarden in Norway (Paus et al., 2015).

## **1.4. Objectives**

The objective of this thesis is to investigate the effect of bioretention cells on an urban catchment at Lademoen, which is traditionally developed with combined sewers. The study will explore the differences in CSO activity for scenarios with and without SUDS for present and future climates.

More specifically:

1. To what extent can the implementation of SUDS reduce the CSO activation frequency and discharge volume?
  - a. Evaluating the effect of retrofitting online bioretention cells on the CSO in a traditionally developed urban area using the LID editor in SWMM.
2. Which effect can the implementation of bioretention cells have on the CSO in a future climate?
  - a. Comparing simulation results from scenarios with and without SUDS using future, climate-modelled precipitation data.

## 2. Method

### 2.1. Selection of project area and land use analysis

The selection of the project area for this master's thesis was based on the findings from the project thesis conducted during the fall semester of 2022 (Appendix A7). The analysis of the sewer system was carried out using a MIKE+ model provided by Trondheim Municipality. The model consisted of the entire system for Møllenberg sewage zone. By examining the elevation profiles of nodes, the flow path of water within the system was determined. The preliminary project thesis revealed that some sections within the project area drain into a primary pipeline originating from the Møllenberg region, while other pipes direct the flow towards a Combined Sewer Overflow (CSO) structure located at PA31 (Wien, 2022).

To focus on assessing the impact of establishing Sustainable Urban Drainage Systems (SUDS) in the project area, it was decided that only the sub-catchments draining into the CSO OF07 Biskop Grimkjells gate would be included in this thesis. Furthermore, the analysis of CSO reduction resulting from the implementation of SUDS would specifically concentrate on OF07. OF07 was chosen to create a sub-section of the extensive existing model. A large portion of the drainage area for OF07 is located within the project area, which increases the magnitude at which the results of the retrofit can be observed. Additionally, OF07 is located close to the project area boarder, which is sufficient to avoid incoming water downstream of the project area.

### 2.2. Project area site description<sup>2</sup>

The description of the project area is based on site observations made during two excursions on October 1<sup>st</sup>, 2022, and March 19<sup>th</sup>, 2023. In addition, information from Google Maps and Kulturminnesøk was used to supplement the findings.

The project area is situated within an urban section of Trondheim city and is primarily characterized by apartment buildings. The majority of the houses have sloped roofs with roof drains connected to underground pipes. The area is predominantly residential but does also include some local businesses such as hairdressers, cafes and fast food, kindergartens, and Lademoen Kunstverksteder.

Running along the northern border of the project area is a railway, intersected by a total of five crossings. Among these crossings, three are designated for pedestrians, while the remaining two accommodate vehicular traffic. All crossings pass beneath the railway. The largest crossing is located in Nidarholms Gate, a relatively busy road that includes the bus stops Buran and Anders Buens Gate.

Along many of the roads, there are trees of various types and ages. New trees were planted in Lademoen Kirkeallé shortly before the visit on October 1<sup>st</sup>, 2022, and water from the nearby roofs is led here. This street is, however, not part of the project area in this thesis, as the pipes lead to PA31. The project area includes Lademoen Park, which is a recreational area next to Lademoen Church. Although most buildings lack individual gardens, some courtyards contain lawns and trees.

---

<sup>2</sup> The section is derived from the project site description from the project thesis (Wien, 2022) with some modifications. (Appendix, A7)

Many of the houses in the area are considered to be of historical significance, having been constructed in the late 19th century. The wooden houses in the West are protected by the Plan and Building Act, while others are recognized as heritage without specific protection. Figure 4 presents an overview of all buildings in the project area that hold heritage interest on either a national or local scale (Kulturminnesøk, 2022).

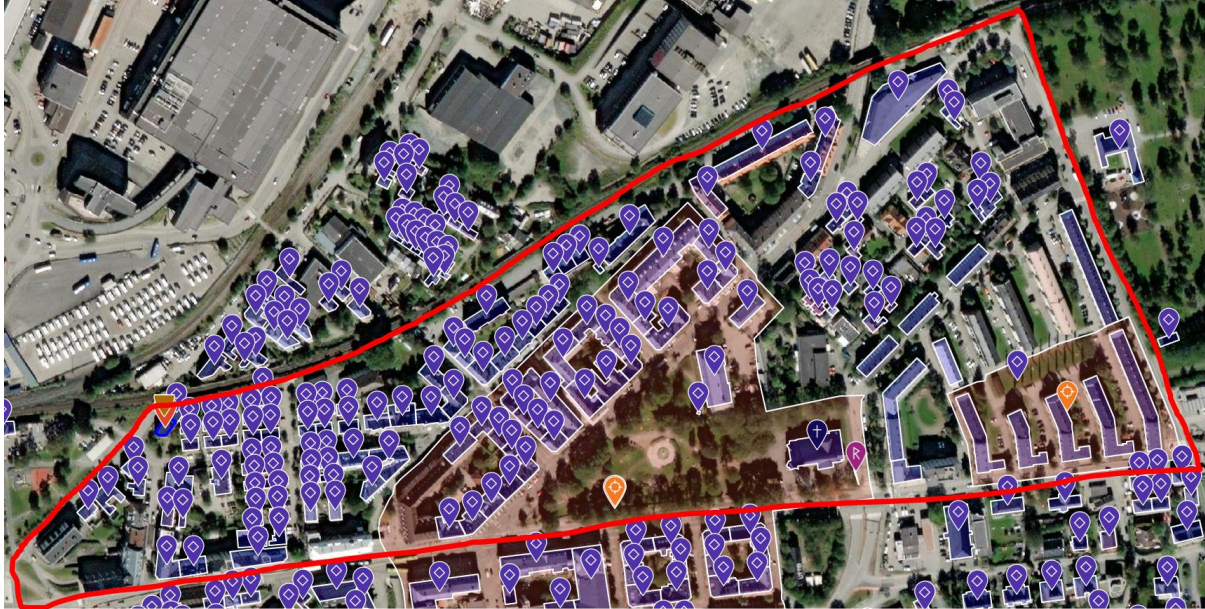
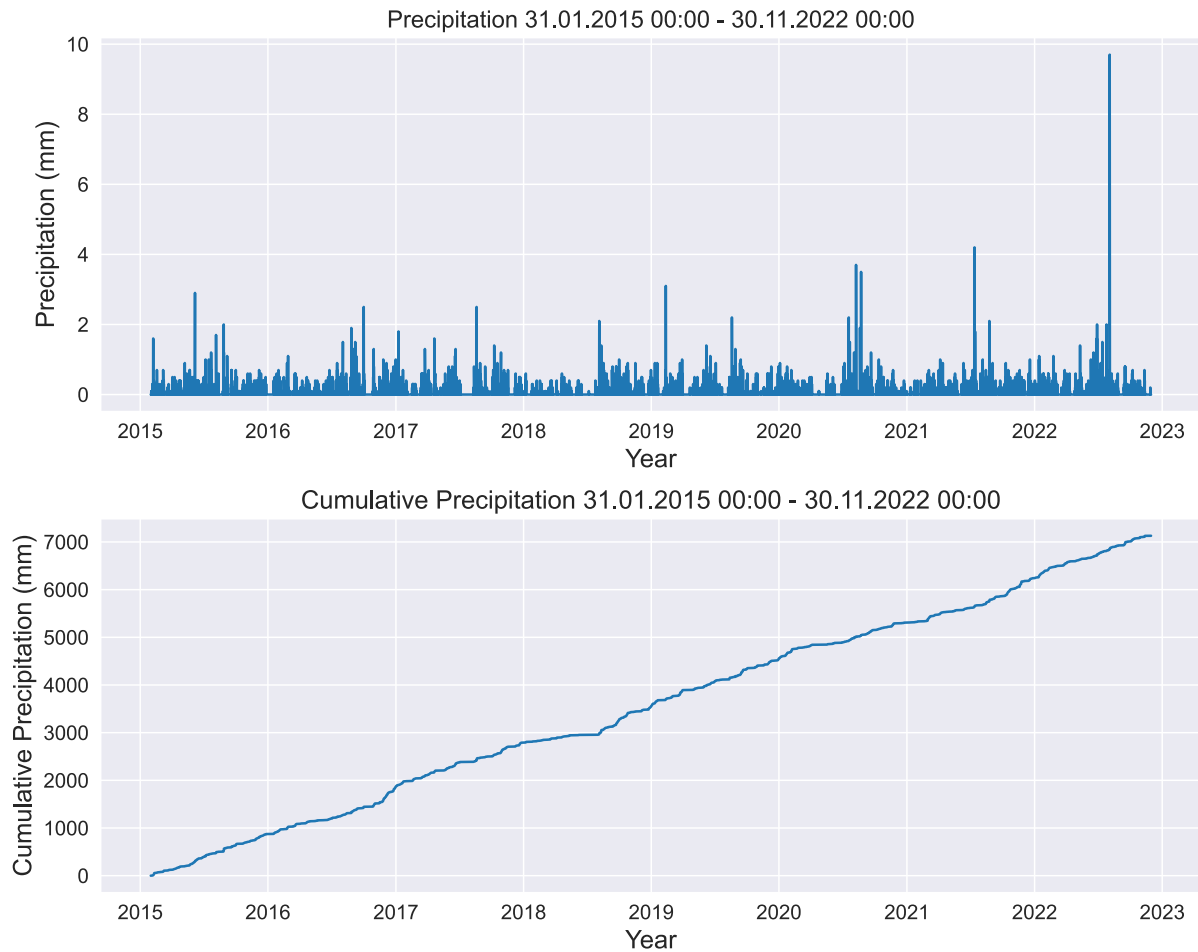

Figure 4: Buildings of heritage interest in the project area (Kulturminnesøk, 2022)

## 2.3. Data Collection

### 2.3.1 Precipitation Data

Two types of precipitation data were used: 1) historical precipitation data with 5-minute resolution from 31.01.2015 to 30.11.2022 downloaded from Frost.no; and 2) future climate-modelled precipitation data for 2070 to 2100 with RCP8.5 downloaded from [Klimaservicesenter](#). The historically observed data was from the closest rain gauge located at Lade, while the future timeseries were made for Risvollan, Trondheim. The future timeseries had a spatial resolution of 1km x 1km and a temporal resolution of 24 hours. The precipitation was given in millimeters. The files include temperature values for each time step; however, this information was not used. Missing datapoints in the historical timeseries were set to NaN (not a number). The plotted historical timeseries and a cumulative precipitation plot for 5-year periods can be seen in Figure 5.



**Figure 5:** Historical precipitation (31.01.2015 to 30.11.2022) Top: timeseries plot of the precipitation (mm) and bottom: cumulative precipitation over the 5-year period.

Ten climate models were used to generate future precipitation timeseries. For each model a folder including files for ten simulations with thirty years of precipitation data and temperatures downscaled from daily to 6-minute temporal resolution was used. The method for downscaling the data is further described in the article [Forecasting green roof detention performance by temporal downscaling of precipitation time-series projections](#) (Pons et al., 2022). The climate models used to generate the future timeseries can be seen in Table 1.

**Table 1:** Climate models used by Klimaservicesenter to provide future precipitation timeseries. RCP8.5

Climate models for future precipitation	
Model number	Model name <sup>1</sup>
0	CNRM, CCLM, 1971-2100
1	CNRM, RCA, 1971-2100
2	EC-EARTH, CCLM, 1971-2100
3	EC-EARTH, HIRHAM, 1971-2100
4	EC-EARTH, RACMO, 1971-2100
5	EC-EARTH, RCA, 1971-2100
6	HADGEM, RCA, 1971-2100
7	PSL, RCA, 1971-2100
8	MPI, CCLM, 1971-2100
9	MPI, RCA, 1971-2100

<sup>1</sup> More information about the climate models can be found in the NVE report [Gridded 1x1 km climate and hydrological projects for Norway](#) (Kwok Wong et al., 2016).

Since the timeseries were modeled, there were no missing data or measurement errors in the datasets. For simplicity, only the first simulation from each model was used. The reasoning behind this is that all the simulations have the same mean precipitation value and are based on the same set of parameters. This reduced the one hundred timeseries to ten series of thirty years.

Only five years of precipitation data from each of the ten modeled future timeseries was used in the study. For each future dataset, three 5-year timeseries were extracted: the five years with the highest, median, and lowest cumulative precipitation values over the 30-year period. This was achieved using the rolling sum for five years and saving separate csv files for each future timeseries containing the maximum, medium, and minimum 5-year precipitation periods. Each timeseries was named according to model number, precipitation classification (maximum, median, or minimum), and the corresponding years encompassed in the timeseries (e.g., "mod0\_max\_2090\_2094"). Figure 6 displays a variation of the future datasets through a cumulative plot of all thirty precipitation timeseries. Before use, the precipitation files were converted to the SWMM-friendly file format dat.

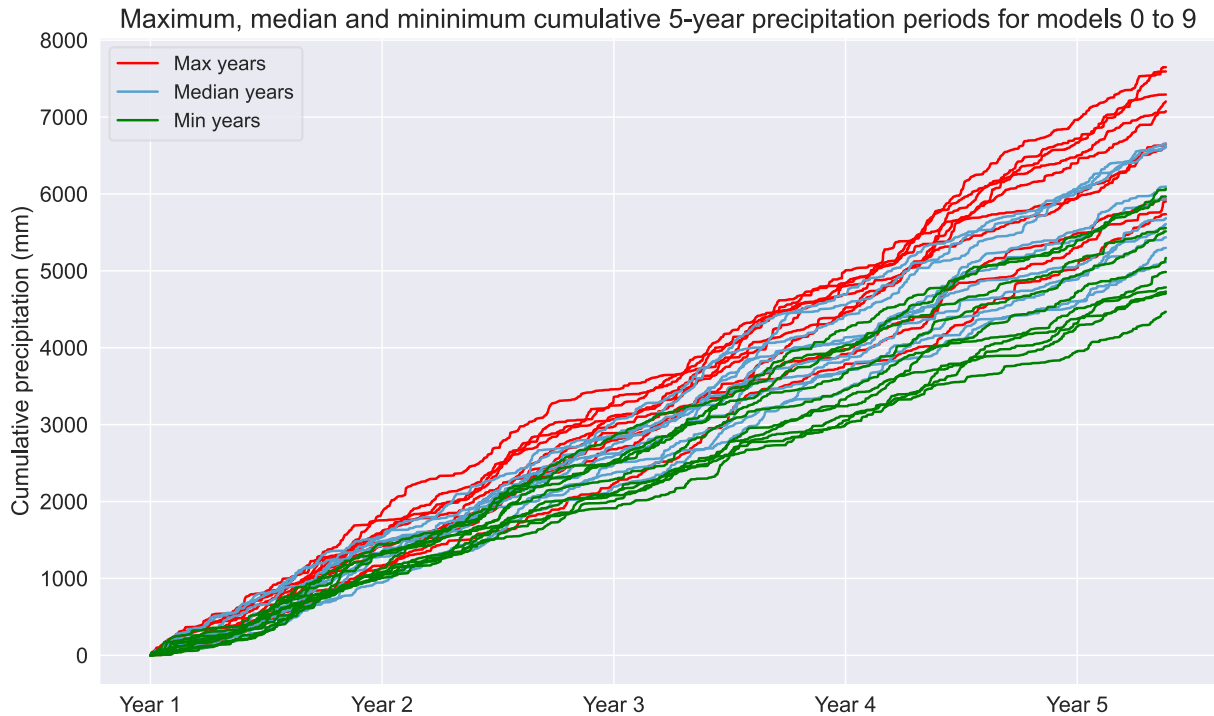

**Figure 6:** The variation of the future climate-modeled precipitation timeseries is displayed cumulatively for each dataset. The ten timeseries with the highest sum of precipitation are marked in red, the ten medians are marked blue, and the ten timeseries with the lowest sum of precipitation are marked green. The duration of the datasets are five years between 2070 and 2100.

### 2.3.2 Operational data from and geometry of OF07 Biskop Grimkjells gate CSO

The operational data was presented in the form of Excel files containing one year of data spanning from 2015 to March 2023. These individual timeseries were combined into a unified dataset, featuring columns representing 5-minute resolution timesteps, water level measurements at each timestep, and a column binary indicating the operational status of the CSO (active or inactive).

An analysis of the dataset was conducted to determine the minimum water level required to activate the CSO and the maximum water level at which the CSO remains inactive. This analysis involved comparing the water level data with the binary operational status. However, it was observed that the timing of water level measurements and activation registrations did not necessarily align within the 5-minute timesteps recorded. Consequently, this misalignment resulted in unrealistically low water levels triggering the CSO activation. Therefore, the binary operational status was deemed unreliable and not utilized further. Instead, the activation condition was determined based on the geometric properties of the weir.

OF07 is a one-sided weir overflow. The incoming pipe has a diameter of 800 mm, and the outgoing pipe, which leads to the main pipe to PA31 and Ladehammeren Treatment Plant, has a diameter of 300 mm. The outflow pipe starts inside the overflow at an elevation of 2.54 meters above sea level (masl) and ends 77.7 m downstream at an elevation 0.55 masl. The length of the overflow is 3.5 m. The top of the threshold is at elevation of 3.15 masl, which leaves the height of the weir to be 0.61 m. Due to the lack of technical drawings, the geometry of the CSO was gathered through digital tools. A simple conceptual sketch based on the information from the digital tools can be seen in Figure A1 together with pictures from OF07 (Figure A2, Appendix).

The observed water level data, along with the geometric specifications of OF07, was used for calibrating the SWMM. Additionally, the water level observations were plotted together with the simulated results for visual evaluation.

### **2.3.3 Data used in GIS**

QGIS (QGIS 3.22, 2022) was used for conducting land use analysis in the project area. Aerial photos were utilized as a base map and were downloaded from [Norge i Bilder](#). The aerial photos had a resolution of 0.1m x 0.1m. The coordinate system used for GIS data from Norge i Bilder was EPSG:25833 - ETRS89/ UTM zone 33N. (Wien, 2022)

Because the aerial photos were over 2 years old, Google Maps in 2D and 3D with pictures from 2022 was used to validate the information from the aerial photos. [Google Maps](#) was also used to clarify if there were any structures that were covered by vegetation and therefore not visible on the aerial photos. OpenStreetMap from XYZ Tiles in QGIS was used to verify the roads, buildings, and parking lots. OpenStreetMap is an open-source map provided by [OpenStreetMap](#) in QGIS. (Wien, 2022)

Information about the sewer network was provided by Trondheim Municipality, both as shape files for links and nodes and in the form of the MIKE+ -model, from which the attributes for sub-catchments, pumps, and weirs were exported. The coordinate system used for the network was ETRS89/UTM zone 32N.

## **2.4. Modeling application**

SWMM (Storm Water Management Model), developed by the US Environmental Protection Agency (EPA), was used as modeling software. The model was constructed based on a pre-existing calibrated MIKE+ model provided by Trondheim Municipality. Both software tools are used to model hydrological and hydraulic processes in urban drainage systems, however MIKE+, provided by the Danish Hydrological Institute (DHI), features a comprehensive set of modeling tools for various water resources management applications, which were not needed for this study. SWMM, on the other hand, is an open-source software that provides readily accessible manuals, forums, and informational videos online, whereas MIKE+ requires a license (DHI, 2023; US EPA, 2014). Considering these factors, as well as the extensive in-house knowledge at NTNU, it was decided to use SWMM as modeling software.

The SWMM model was developed by exporting the pre-existing MIKE+ model into shape files, which were then imported into QGIS. In QGIS, the components of the model that lay outside the drainage area of OF07 were removed, while the remaining model shapefiles were imported into SWMM. The shape files from MIKE+ contained most of the relevant information needed for the SWMM mode, however, the catchment widths were manually adjusted based on findings obtained from QGIS. One of the most important parameters that was transferred from the MIKE+ model was the pervious to impervious area ratio for all sub-catchments.

To ensure comprehensive analysis, an outflow point and a rain gauge were incorporated into the model. It was assumed that precipitation falls uniformly, and snowpack was not included in the simulation. Furthermore, to accurately represent the hydraulic conditions, the height of the weir in OF07 was corrected to 0.61 m. Green-Ampt was set as the infiltration model.



### 2.4.1 Area included in the model

The drainage area of OF07 was determined using QGIS software and through the pathway of the water, which was found as described in Section 2.1. To obtain accurate data the findings were compared with a drainage map provided by Trondheim Municipality (Trondheim Municipality, 2023). A new shapefile was created for the drainage area. Figure 7 illustrates the sub-catchments within the project area that drain into OF07.

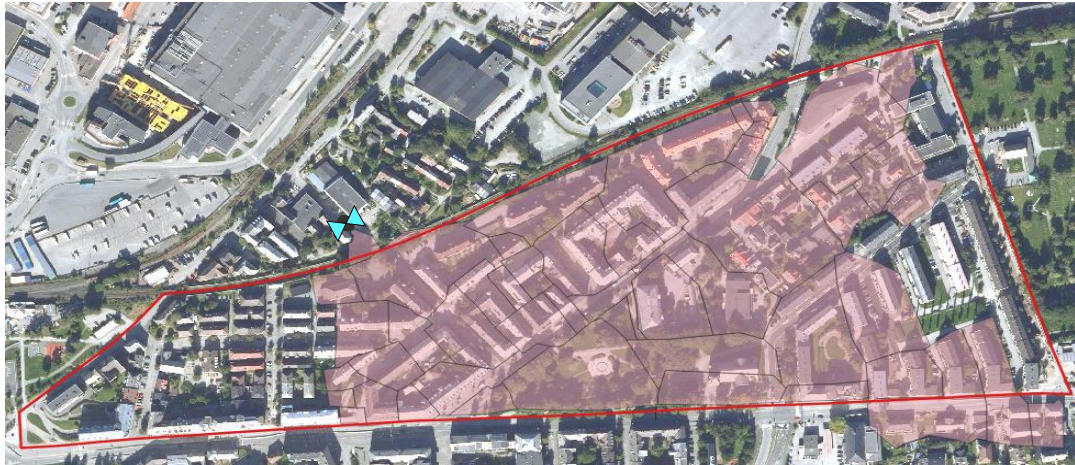

**Figure 7:** Sub-catchments in the project area that drain to OF07. OF07 is marked in blue.

Considering that a sizable portion of the drainage area is not part of the project area and is located on the south side of Innherredsveien, it becomes essential to consider the sewage flow from this area when evaluating the effects of implementing SUDS. Consequently, all the sub-catchments located upstream of OF07 were included in the SWMM model to comprehensively assess the impact. For reference, Figure 8 depicts the sub-catchments included in the SWMM model. BRC were, however, only included in the sub-catchments in the project area.

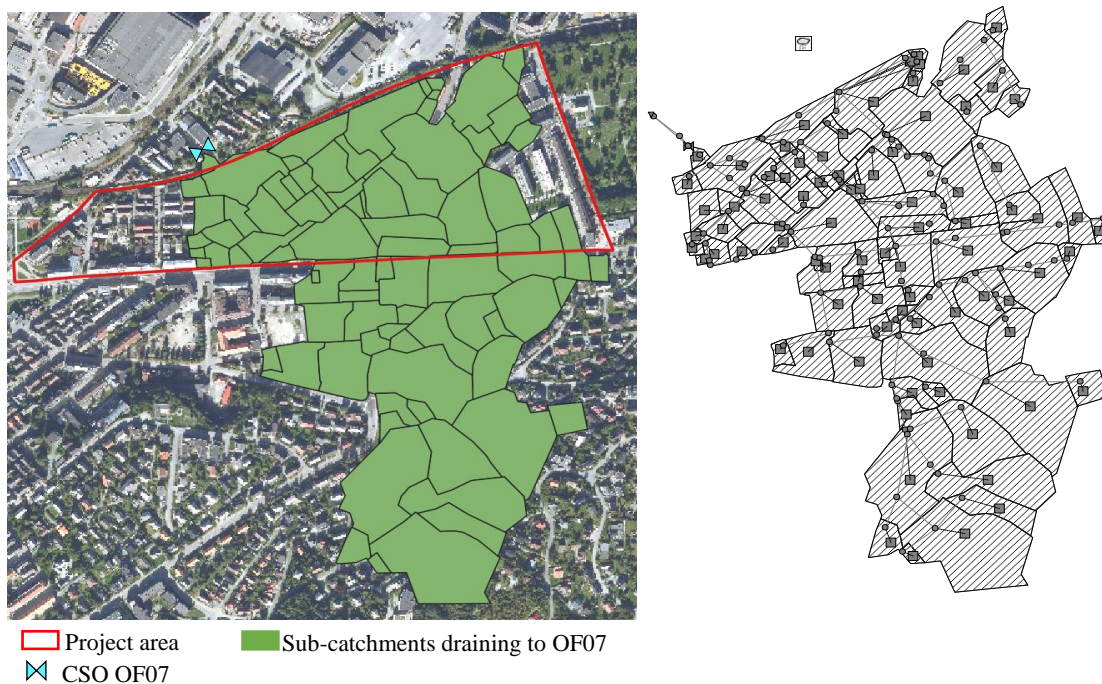

**Figure 8:** All sub-catchments that drain to OF07 were included in the SWMM model and the map in SWMM. The sub-catchments inside the red area are sub-catchments included in the project area.

### 2.4.2 Calibration of the SWMM model

Two calibration runs of the SWMM model were done using the observed (measured) water levels in OF07. The parameters included in the calibration and their bounds can be seen in Table 2. The parameters chosen was based on the parameters used in calibration in Hernes et al. (2020). Note that the base value, which is included in the description of dry weather flow (DWF), was only included in the first calibration run and kept fixed for the second run. All initial values for the calibrated parameters were defaults, and parameters that were not calibrated were either transferred from the calibrated MIKE+ model or kept at SWMM default.

**Table 2:** Model parameters calibrated and the bounds for which they were calibrated for.

Calibrated parameters	
Sub-catchments	
	<b><u>Bounds</u></b>
Soil capillary suction head (mm)	1.00 - 100.00
Soil hydraulic conductivity (mm/hr)	0.00 - 100.00
Manning n for impervious area	0.010 - 0.30
Manning n for pervious area	0.01 - 0.30
Depth of depression storage on impervious area (mm)	0.00 - 5.00
Depth of depression storage on pervious area (mm)	0.00 - 5.00
Conduits	
Manning's roughness coefficient	0.01 - 0.30
Base value <sup>1</sup> (m <sup>3</sup> /s)	0.00 - 0.10
<sup>1</sup> Included in calibration run 1 only	

The calibration was performed using `swmm_api` and the optimization function Differential Evolution from Scipy. More information about Differential Evolution can be found on the website of [Scipy](https://docs.scipy.org/doc/scipy/) and in the paper by Storn & Price (1997). The code for the calibration can be seen in Appendix A3.

To perform the calibration, an objective function was needed to measure the goodness-of-fit of the model. Some commonly used objective functions are NSE, KGE, RMSE, R<sup>2</sup>, and MSE, which each have their strengths and weaknesses. The choice of objective function depends on the goal of the calibration.

For the calibration, Nash-Sutcliffe Efficiency (NSE) was selected as the objective function. NSE provides an objective and quantitative measure to assess the goodness-of-fit between the simulated and observed datasets. NSE is sensitive to outliers and magnitude biases (McCuen et al., 2006). This is a wanted feature since this thesis requires a model that replicates peak values in the water level and thereby the frequency of CSO events. The formula for NSE for water levels can be seen in Equation 1.

$$NSE = 1 - \frac{\sum_t^T (H_{obs}^t - H_{sim}^t)^2}{\sum_t^T (H_{obs}^t - \bar{H}_{obs})^2} \quad [1]$$

where

$H_{obs}^t$  = observed water level in timestep t

$H_{sim}^t$  = simulated water level in timestep t

$\bar{H}_{obs}$  = the mean of all observed water levels in the period

The Nash-Sutcliffe Efficiency is described as the sum of squared differences between the observed and simulated values in every timestep divided by the sum of squared differences between the observed values and the mean of the observed. It measures the extent to which the model accounts for the variation in the observations in comparison to using the mean as the prediction. The NSE ranges from negative infinity to the perfect fit value of one. An NSE of zero indicates no better performance than using the mean, while negative values indicate worse performance than using the mean. (Bennett et al., 2013)

Kling-Gupta Efficiency (KGE) could have been used for a better representation of volume since it focuses on following the shape of the data. However, KGE underestimates high values and overestimates low values (Gupta et al., 2009). Due to the underestimation of peaks, KGE was not used for calibration.

Since Differential Evolution optimizes using minimization, the calibration function was set to return NSE subtracted by one. The calibration function also returned the NSE of the simulation results using the optimized parameters found by Differential Evolution.

The period of precipitation used for calibration was 16.06.2017 00:00 to 23.06.2017 00:00 with a 5-minute resolution. The period was chosen because it consists of a clear start and ending with dry periods on each side, two large peaks, and multiple smaller events in which CSO events were likely to occur. A plot of the precipitation can be seen in Figure 9. The calibration time was around 10 hours. One calibration with 10-minute resolution was also tried but was not used due to inefficient results.

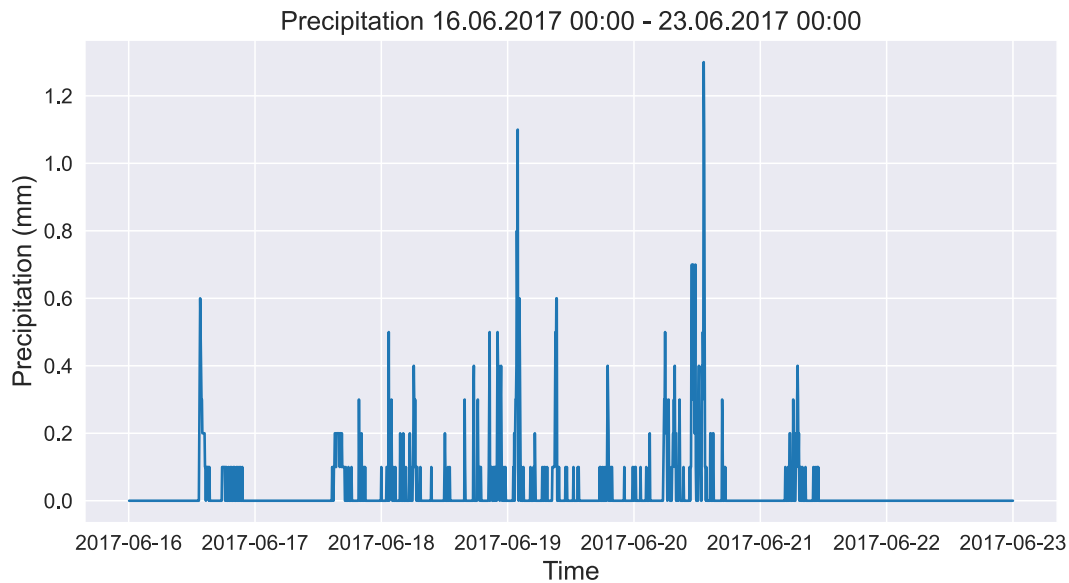

**Figure 9:** Precipitation event used for calibration of the SWMM model.

### 2.4.3 Validation of the SWMM model

Validation of the calibrated model was conducted using five periods, which can be seen in Table 3. The validation runs were managed in Python using the same function `run_swmm` defined in the calibration code (Appendix A3). The validation was done by running simulations and calculating the NSE of the results using the observed data for the corresponding period. The parameter set that was used in further simulations was based on the performance of the validation runs.

**Table 3:** Periods of timeseries used in validation.

Validation run number	Period
1	02. - 05.08.2022
2	08. - 09.08.2020
3	18.07 - 19.07.2020
4	18.12 - 19.12.2021
5	01.01.2018 - 31.11.2022

A water balance calculation was performed on precipitation and simulation results for validation dataset 2 to confirm that the volume of water entering the system did not differ more from the volume of water exiting the system than what is expected due to infiltration. This was done to ensure that there were no extreme losses in the model.

### 2.4.4 Area calculations

The land use in the project area was derived from the analysis done in Wien (2022) in the form of shapefiles. The analysis was done using QGIS. The following section describes the process.

To find the area which is unavailable for SUDSs, shapefiles containing polygons for all roofs, marked parking spaces, and a part of Lademoen Park were imported, as well as a shapefile containing lines for roads. The shapefile for marked parking spaces refers to parking spaces

that are included in OpenStreetMap. OpenStreetMap does not include parking spaces on the sides of the roads. The shapefile with an area in Lademoen Park contains the area which is currently occupied by walkways and garbage disposal containers.

The area of each polygon was calculated using the \$area operator in QGIS, and the lengths of road segments were calculated using the \$length operator. The attribute tables of the shapefiles were then transferred to Excel, where the total areas and lengths were calculated by simple summation. To simplify and minimize the manual work in QGIS, it was assumed that all roads were 4 m wide and that there were 2 m of sidewalk on each side of the road. However, due to a calculation error, the only half of the road width and sidewalks were included. The total area of roads, sidewalks, roofs, parking spaces, and the occupied area in Lademoen Park were considered areas which is theoretically unavailable for the implementation of SUDS.

The available area was calculated by subtracting the sum of the unavailable areas (park, roads and sidewalks, and marked parking) from the total area in the project area. Using the assumption that 25% of the theoretically available area in practice is available, the actual percentage of the area that can be retrofitted for SUDS was calculated. The area BRC added to each sub-catchment was calculated by multiplying the area of the sub-catchment by the actual percentage. The conservative assumption of 25% of the theoretically available area actually being available was based on the distribution of private and public properties through visual analysis using QGIS.

#### **2.4.5 Implementation of SUDS in SWMM**

The implementation of BRC was done using the LID Controls editor in SWMM (Rossman, 2015, p. 245). A standard BRC was created and implemented in all relevant sub-catchments (Figure 7). The area of BRC implemented in each sub-catchment was based on the assumption that 25% of the theoretically available area in the project area was available for the implementation of SUDS. Due to the calculation error of roads and sidewalks, 31% of the theoretically available area was retrofitted to BRC instead of 25%, which was planned.

**Table 4:** Parameter values and their sources for the bioretention cell module in SWMM.

Bioretention Cell		
Surface		
Berm height (mm)	200 <sup>1</sup>	(Tek17)
Vegetation Volume fraction	0.1	(Chui et al., 2016)
Surface Roughness (Manning n)	0.1	(Chui et al., 2016)
Surface Slope (%)	1	(Chui et al., 2016)
Soil		
Thickness (mm)	750	(Paus & Braskerud, 2013)
Porosity (volume fraction)	0.39 <sup>2</sup>	(Hernes, 2018)
Field Capacity (volume fraction)	0.26 <sup>2</sup>	(Hernes, 2018)
Wilting Point ( volume fraction)	0.06 <sup>2</sup>	(Hernes, 2018)
Conductivity (mm/hr)	100	(Paus & Braskerud, 2013)
Conductivity Slope	10 <sup>3</sup>	(Rossman, 2015)
Suction head (mm)	131.65 <sup>4</sup>	(Rawls et al., 1983)
Storage		
Thickness (mm)	200 <sup>5</sup>	(Paus & Braskerud, 2013)
Void Ratio (Voids/Solids)	0.67	(Rossman, 2015)
Seepage Rate (mm/hr)	10 <sup>6</sup>	(Rawls et al., 1983)
Clogging Factor (-)	0 <sup>3</sup>	(Rossman, 2015)
Drain		
Flow coefficient (mm/hr)	200	(Hernes, 2018)
Flow exponent	2.2 <sup>2</sup>	(Hernes, 2018)
Offset (mm)	50	(Paus & Braskerud, 2013)
Open level (mm)	0 <sup>3</sup>	(Rossman, 2015)
Close Level (mm)	0 <sup>3</sup>	(Rossman, 2015)
Control curve	Not relevant <sup>3</sup>	(Rossman, 2015)
<sup>1</sup> §8-3. Outdoor living area chapter (4) as measure against drowning <sup>2</sup> Calibrated values based on bioretention cell in Oslo. <sup>3</sup> SWMM default <sup>4</sup> Middle value of Wetted front capillary pressure <sup>5</sup> Assuming drainage pipe Ø110 with offset 50 mm <sup>6</sup> Value for clay (NGU.no)		

#### 2.4.6 Running SWMM simulations

A total of sixty-two simulations were run: thirty-one timeseries for the scenario without SUDS (the *do-nothing scenario* called *Scenario 1*) and then again for the scenario with implementation of the BRC described in Section 2.4.5 (*Scenario 2*). Of the sixty-two runs, two were for historical data and sixty for future data. The SWMM model was edited according to timeseries properties using the package *swmmio*, which is a package allowing users to access and modify a SWMM model input file (.inp) from Python (*swmmio*, 2023).

Thereafter, the model was run using the *swmm\_api*'s package *swmm5\_run* (Pichler, Markus, 2022) from a remote computer with high capacity. The simulations took 45 minutes each due to the high resolution and length of the simulated period. The timeseries for water depth in

OF07 was extracted from the out file created by the simulation using `swmm_api`'s module `read_out_file` for each run. The simulation results were saved as individual csv files containing the 5-minute timesteps and water levels in OF07. The code for running simulations using Python can be seen in Appendix A4.

## 2.5. Data Analysis

### 2.5.1 Correction factors for simulated water levels

Due to the SWMM model's underestimation of water level in OF07 two correction factors for the water levels were found. (Appendix A5) To do the optimization of the correction factor the optimisation function Differential Evolution from Scipy was used.

The first optimized parameter ( $k_1$ ) was found by minimizing the difference between the number of days in which a CSO at some point occurs. The second optimized parameter ( $k_2$ ) was found by minimizing the difference in the number of timesteps with the water level above the weir threshold at 0.61m. In the calculations, the optimized parameters were defined as numbers by which the simulated depth was divided to obtain the best fit between the simulated and observed water levels. The correction factors were later defined as  $C_1$  and  $C_2$ , where  $C_i = \frac{1}{k_i}$ ,  $i = [1, 2]$ .

Two correction factors were used because  $C_1$  gives the best results for daily frequency, while  $C_2$  gives the best results for analysis for the number of timesteps (duration). The correction factors were applied for all further analysis, resulting in two sets of results: one for each correction factor. The correction factors were not applied to the observed dataset.

### 2.5.2 Depth duration curves

The differences in water level for the simulated scenario 1 and 2 results were plotted as depth duration curves. Duration curves describe the duration (x-value) in the period analyzed for which a phenomenon (y-value) occurs. In this case, the depth duration curve describes the number of hours in which the water level in OF07 is at a certain depth in a 5-year period.

The curves were made by first sorting the datasets in descending order and assigning them a plotting position according to their placement (rank) in the sorted dataset. The plotting position was derived from 2, which gives the x-values in the plot as decimals between 0 and 1. The plotting position was multiplied by the number of hours in five years (43800hrs) to display the duration in hours.

$$\text{Plotting position} = \frac{n}{N+1} \quad [2]$$

where

$n = \text{rank}$

$N = \text{total number of ranks}$

For the future timeseries, the data was plotted as the mean of each timestep for all timeseries, together with the 5<sup>th</sup> and 95<sup>th</sup>-percentiles. The result was a depth duration curve with water level on the y-axis and hours with the specific water level on the x-axis. For this thesis, the

period was five years for both observed, historical, and future data. The depth duration curves can be seen in Section 3.6.

### 2.5.3 Frequency and volume analysis

The number of days and the number of timesteps in which the water level activates the CSO were found by iterating through all rows in the datasets containing water level values for each 5-minute timestep. With a boolean criteria, “True” was returned if the water level in the timestep was higher than the height of the weir (0.61 m) and “False” if lower. The dates were then extracted using the function “unique” from NumPy and setting “return\_counts” equal to “True” to return count of timesteps in the day for which the boolean statement for water level was “True”. The results of the analysis were tables with dates in which the CSO was active in one column and the number of timesteps each day in a second column.

The volume overflowing was calculated through the calculation of flow over the weir based on the water level in the overflow chamber. The formula for discharge from overflows can be found in VA-blad 74 (Miljø Blad, 2007) and is displayed in Equation 3. The flow is a function of the geometry of the CSO and the water level in timestep  $t$ . The height  $H$  is the height multiplied by the correction factors.

$$Q_t = \frac{2}{3} * C_d * B * (2g)^{\frac{1}{2}} * H_t^{1.5} \quad [3]$$

where

$Q_t$  = water flow over the overflow weir in a timestep ( $m^3/s$ ) in timestep  $t$

$C_d$  water flow coefficient w/foam weir (-)

$B$  = length of the weir (m)

$g$  = gravitational acceleration ( $m/s^2$ )

$H_t$  = water level above the weir (m) in timestep  $t$

From the flow, the volume escaping the sewer system through the CSO was calculated by multiplying the flow by the length of the timestep. For the historical events, the timesteps were five minutes, and for the future timeseries, the timesteps were six minutes.

A frequency analysis was conducted. The number of days and number of timesteps with active CSO were counted for each model, scenario, and correction factor. The results from the future frequency analysis were plotted in a boxplot (Figure 14) to show the variation of the results for scenarios 1 and 2 with correction factors C1 and C2. A boxplot for the variation in volume for the scenarios and correction factors was also plotted in the same figure (Figure 14). The plots show the 25<sup>th</sup> to 75<sup>th</sup> percentiles.

In addition to the analysis of OF07, the total volume reduction from the implementation of BRC was calculated by extracting the flow from an upstream pipe. The pipe chosen was L190252, which is the main pipe where all the water from the drainage area is transported before entering OF07. The selected pipe can be seen in Figure 10. The output file from SWMM was read, and the flow in the pipe was extracted and saved as csv files for scenarios 1 and 2 for



historical and future simulations. The volume reduction was calculated by multiplying the flow in every timestep with the period in each step to get the volume in each timestep. Thereafter, the sum of volumes for scenario 2 was subtracted from the sum of volumes for scenario 1 to get the reductio caused by the BRCs.



**Figure 10:** Pipe L190252 (red) leading into OF07 (blue) was used in the calculation of the volume reduction entering the system caused by BRC. Zoomed in figure from the SWMM model map.

#### 2.5.4 Seasonal variation

Seasonal variation of the days with CSO events was found for scenarios 1 and 2 for historical and future timeseries. Only one future timeseries, mod0\_max\_2090\_2994, was used to show the distribution. The data was corrected using the correction factor C1 for the best fit of the number of days with CSO activation. First, all dates on which the CSO was activated at some point during the day were extracted together with the number of timesteps for which the water level was higher than the threshold water depth for the CSO. This was done using the method described in Section 2.5.3. Thereafter, the data was sorted into lists according to season based on the dates. The dates in the months December, January, and February were classified as winter, March, April, and May as spring, June, July, and August as summer, and September, October, and November as fall (Ringnes et al., 2023). The data points were plotted, with the date on the x-axis and the number of timesteps with active CSO on the y-axis. The points were coded with shapes and colors according to the season for easy visualization of the seasonal variation.

#### 2.5.5 Design precipitation event and bioretention cell area calculation

To compare the BRC area that was implemented with the BRC area that is needed, the design precipitation events and the area needed correspondingly were calculated.

First, the precipitation event for which the implemented BRC can manage was calculated by solving for  $P_{design}$  in Equation 4. The equation describes the surface area of a raingarden or BRC as a function of properties of the soil and catchment, and precipitation (WEF & EWRI (U.S.), 2012). BRC and raingardens use the same design criteria, which means that Equation 4 is applicable for the BRC in the model.

$$A = \frac{A_{drain} * C * P_{design} * d_f}{K_{sat} * t_f * (h_f + d_f)} \quad [4]$$

where

A = surface area of the raingarden or BRC (m<sup>2</sup>)

A<sub>drain</sub> = drainage area (m<sup>2</sup>)

C = average runoff coefficient of the drainage area (-)

P = design precipitation event (cm/hr)

d<sub>f</sub> = depth of the media filter (cm)

t<sub>f</sub> = drainage time (hr)

K<sub>sat</sub> = saturated hydraulic conductivity (cm/hr)

h<sub>f</sub> = average height of water above filter media, usually  $h_f = \frac{1}{2} * h_{max}$  (cm)

where h<sub>max</sub> is the maximum height above the filter media possible before overflow (berm height).

The drainage time (t<sub>f</sub>) was calculated as a function of catchment length, slope, and runoff coefficient using Equation 5 (Fed. Aviation Agency, 1970).

$$t_f = \frac{1.8(1.1 - C) * \sqrt{D}}{\sqrt[3]{S}} \quad [5]$$

where

t<sub>f</sub> = drainage time (hr)

C = average runoff coefficient of the drainage area (-)

D = length of overland flow (m)

S = average slope of catchment (% as decimal)

In the calculation, the total surface area of the implemented area of BRC was used as area (A), and the sum of the area of the project area sub-catchments was used as A<sub>drain</sub>. The parameters K<sub>sat</sub>, d<sub>f</sub>, and h<sub>f</sub> were set according to Table 2 and Table 4. The average runoff coefficient (C) is the same for Equation 4 and Equation 5, and was set to 0.65 for urban neighborhoods (SWRCB, 2011). The length of overland flow was set to the average width of the sub-catchments.

The design precipitation for the historical and future precipitation events was based on the rule of thumb that an urban drainage system can manage 90% of the yearly precipitation volume while the excess 10% is left on the surface. The same method for finding the 90% precipitation threshold as in Wien (2022) was used. The assumption of step 1 being 90% of the yearly

volume is lower than, for instance, what is described by Paus (2018). The code can be found in Appendix A6. The needed area (A) for the historical precipitation was calculated using Equation 4, where the 90% threshold was set as  $P_{\text{design}}$ . For the future precipitation datasets, the median of all 5-year periods with maximum precipitation volume was used.

The comparison between the implemented area of BRC in the model and the needed area to manage historical and future precipitation was done by looking at the difference between the implemented area and the needed area.

### 3. Results

#### 3.1. Area calculations

The total drainage area of OF07 consists of 304541 m<sup>2</sup>, of which 45% (136357 m<sup>2</sup>) contains sub-catchments in the project area in which SUDS was implemented. In the project area, 3490 m<sup>2</sup> were parking spaces, 35133 m<sup>2</sup> were projected roof areas, and the unavailable area in Lademoen Park had an area of 490 m<sup>2</sup>.

The area of roads and sidewalks was 31764 m<sup>2</sup>, however, after the simulations it was discovered that only half of the area had been included. The consequence of the calculation error was that more area than was actually accessible was assumed to be available. Using only half of the area for roads and sidewalks left a total of 81361 m<sup>2</sup>, which was theoretically available for implementation of SUDS, while using the whole area leaves 65479 m<sup>2</sup>. The latter was the area assumed to be available in the next calculations, which leads to 31% of the area being converted to BRC instead of 25%. BRC were implemented in 31% of the total theoretically available area, which corresponds to 14.9% of each sub-catchment.

#### 3.2. Calibration results

The two calibration runs generated two sets of optimized parameters. In the second run, the base value was maintained constant, and due to the stochastic nature of Differential Evolution, the parameter values in the two sets exhibited considerable differences, despite the NSE results being closely aligned in terms of values. Table 5 shows the resulting parameter sets for calibration runs 1 and 2.

**Table 5:** Calibration results for calibration run 1 and 2.

Calibrated parameters		
Sub-catchments		
	<u>Parameter set 1</u>	<u>Parameter set 2</u>
Soil capillary suction head (mm)	9.48	39.03
Soil hydraulic conductivity (mm/hr)	0.69	1.36
Manning n for impervious area	0.28	0.28
Manning n for pervious area	0.18	0.21
Depth of depression storage on impervious area (mm)	0.66	2.65
Depth of depression storage on pervious area (mm)	3.53	3.07
Conduits		
Manning's roughness coefficient	0.14	0.13
Base value <sup>1</sup> (m <sup>3</sup> /s)	1.77E-05	1.77E-05

<sup>1</sup> Calibrated in calibration run 1 only and kept fixed for run 2.

Figure 11 shows the plotted values for the observed water level in OF07 and the simulated results for parameter sets 1 and 2, together with a plot of the precipitation. The NSE of simulation result for parameter set 1 (NSE1) was 0.338, while the simulation result for parameter set 2 (NSE2) was 0.339. Even though parameter set 2 had a higher NSE, the visual observation of the plot concludes that parameter set 1 has a better ability to replicate the peaks. Both parameter sets were able to replicate the shape of the graph, however both strongly underestimated the magnitude of the peaks. Both parameter sets manage to fit the base flow in

dry periods. It should be noted that none of the parameter sets are able to simulate the peak at which the CSO is active. No conclusion about which parameter set to use for further simulations was drawn based on the results from the calibration.

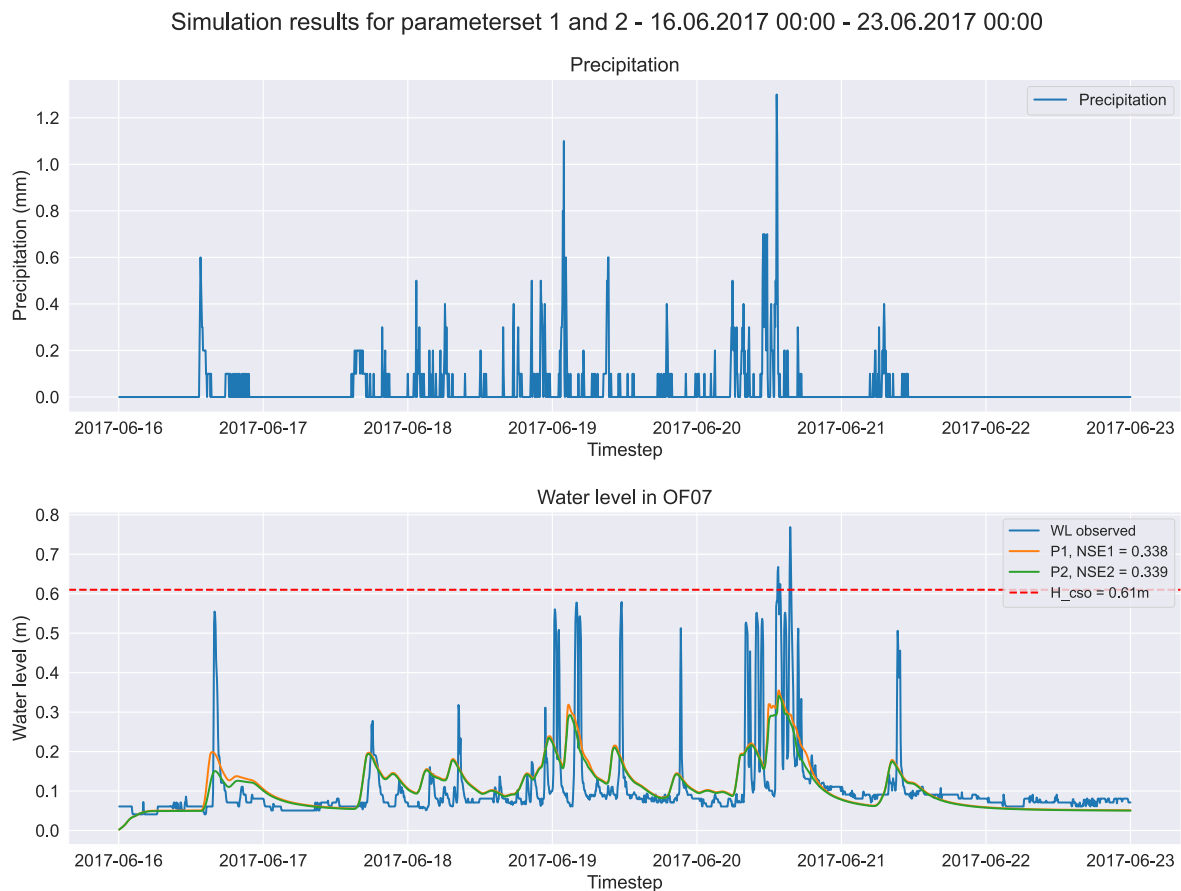

**Figure 11:** Plot of precipitation, observed water level for OF07, and simulated water levels with parameter sets 1 (P1) and 2 (P2) from calibration.  $H_{cso}$  (red line) is the water level for CSO activation.

### 3.3. Validation results

The NSE results from the validation runs can be seen in Table 6. The results show that both parameter sets perform worse for shorter periods than for longer ones. The best NSE result was NSE1 for validation run 4. This timeseries was for a winter precipitation event where the temperatures were above zero and there was no snow pack in the area on the day or in the days prior to the event (yr.no, 2021). For validation run 5, the longest period and the period which later was used for simulations, NSE1 was 0.359 while NSE2 was 0.344. A plot of validation run 5 can be seen in Figure 12. None of the parameter sets was able to recreate peaks high enough for CSO activation in any of the validation runs. Despite the underestimation of the model, no more calibrations were run due to limited time. Parameter set 1 was chosen for further simulations based on the performance in the validation.

**Table 6:** NSE-results from validation runs 1 to 5 for parameter set 1 and 2.

Validation run number	Period	NSE1 <sup>1</sup>	NSE2 <sup>2</sup>
1	02. - 05.08.2022	0.113	0.177
2	08. - 09.08.2020	0.118	0.134
3	18. - 19.07.2020	0.180	0.203
4	18. - 19.12.2021	0.417	0.282
5	01.01.2018 - 31.11.2022	0.359	0.344

<sup>1</sup> NSE for simulation with parameter set 1  
<sup>2</sup> NSE for simulation with parameter set 2

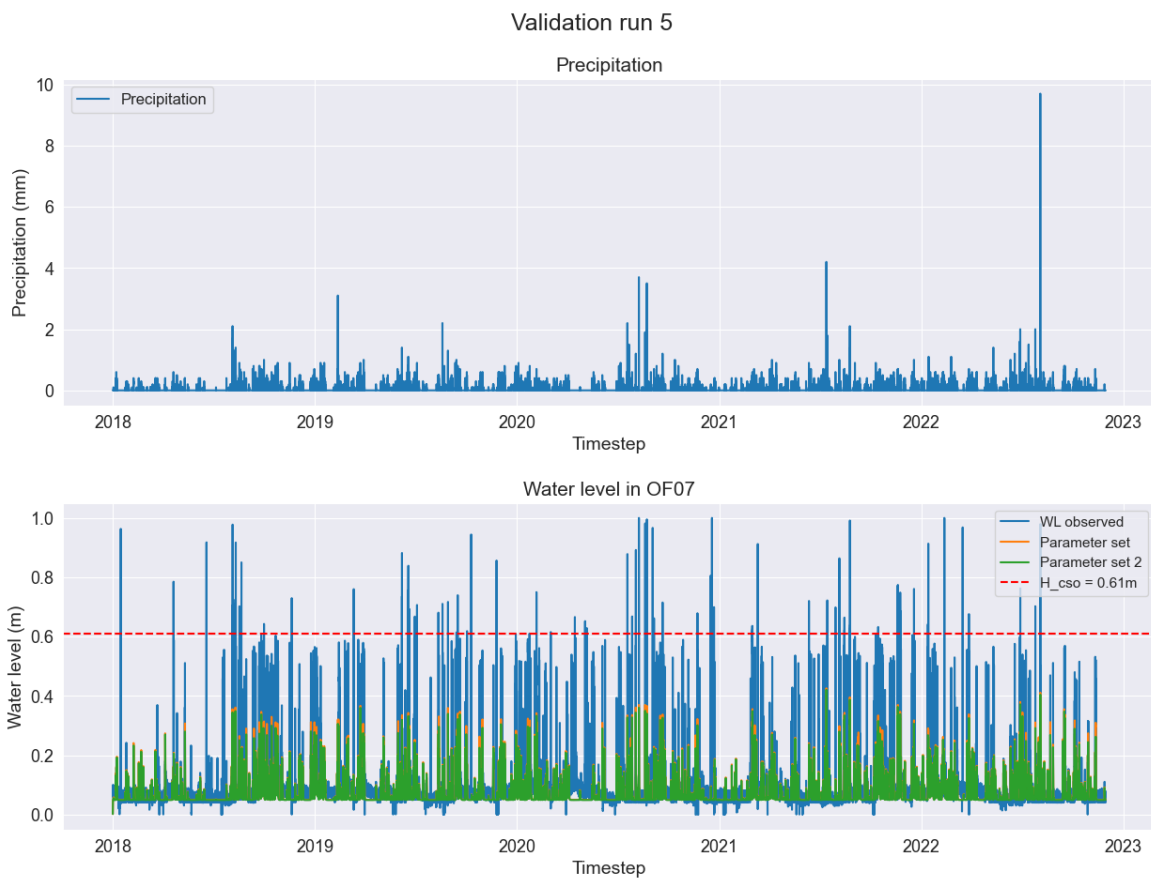

**Figure 12:** Simulation results for validation run 5 for parameter sets 1 and 2. Parameter set 1 performs slightly better in terms of replicating the peak values.  $H_{cso}$  (red line) is the water level for CSO activation.

The water balance was calculated on validation period 2 and showed that out of the 12 mm of precipitation that entered the system, 7.5 mm exited the system through the outlet node. The water balance between volumes entering and exiting the system did not differ more than expected due to infiltration.

### 3.4. Results of optimization of correction factors

Since the SWMM model was not able to accurately replicate the peak values in the observed data from 2018 to November 2022, correction factors were found. The optimized parameter for matching the observed number of days with active CSO (70 days) with the simulated number

of days,  $k_1$ , was 0.49, resulting in the correction factor  $C_1$  equal to 2.04. Additionally, the optimized parameter for the number of timesteps with active CSO (510 timesteps),  $k_2$ , was found to be 0.55, leading to the correction factor,  $C_2$ , being equal to 1.82. The results from the optimization of correction factors can be seen in Table 7.

**Table 7:** Correction factors  $C_1$  gives the best fit for the number of days and  $C_2$  gives the best fit for the number of timesteps with active CSO.  $C_i = 1/k_i$ .

Optimized parameters, $k_i$ , and correction factors $C_i$			
$k_1$	$C_1$	$k_2$	$C_2$
0.49	2.04	0.55	1.82

Multiplying the simulated result with the correction factors increases all values. The result was that the graph was stretched vertically as well as elevating the base water level. For correction factor  $C_1$ , the number of days in which there are CSOs (70 days) was precisely replicated, whereas the number of time steps with active CSO (510 timesteps) was replicated with  $C_2$ .  $C_1$  leads to a too high number of timesteps with CSO, whereas  $C_1$  leads to too few days with CSO. None of the correction factors replicates the magnitude of the peaks, however, they do reproduce the frequency. Figure 13 shows the effect of the correction factors on the simulated results from validation run 5, parameter set 1.

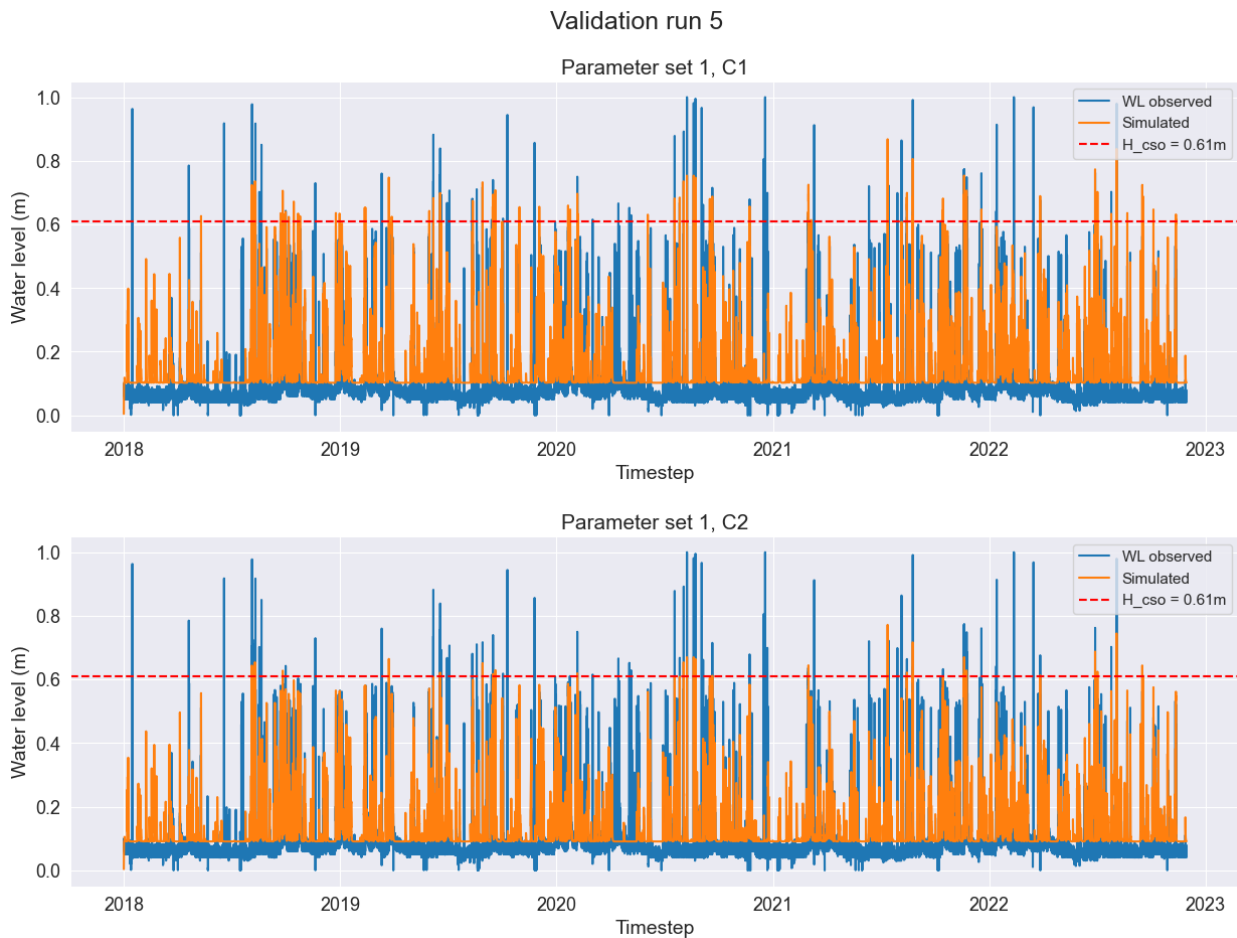

**Figure 13:** Effect of correction factors  $C_1$  and  $C_2$  on the simulated water level for validation run 5 using parameter set 1. All values have been raised creating an elevated plot.  $H_{cso}$  (red line) is the water level for CSO activation.

### 3.5. Frequency and volume analysis

#### 3.5.1 Historical frequencies and volumes

The analysis of the observed dataset showed that there were 70 days in the period in which the CSO was active, and it was active for a total of 510 timesteps. Using correction factor C1 on the simulated data gave the same result for the number of days for scenario 1, and the same applied for the number of timesteps using C2. The volume exiting OF07 directly into Nidelva River was not replicated precisely using any of the correction factors.

The simulation results for scenario 2 showed that the number of days with CSO events was reduced by four days and the number of timesteps was reduced by 166 from scenario 1 when applying C1 and C2, respectively. Scenario 2 with C1 reduced the volume by 14247 m<sup>3</sup> over five years, and scenario 2 with C2 reduced the volume by 4314 m<sup>3</sup>. An overview can be seen in Table 8.

**Table 8:** Frequency and volume results for scenario 1 and 2, correction factor C1 and C2

	<b>Observed</b>	<b>C1</b>	<b>C2</b>
<b>Days S1</b>	<b>70</b>	<b>70</b>	28
<b>Days S2</b>	-	66	24
<b>Timesteps S1</b>	<b>510</b>	2147	<b>510</b>
<b>Timesteps S2</b>	-	1772	334
<b>Volume S1 (m<sup>3</sup>)</b>	61875	61902	5686
<b>Volume S2 (m<sup>3</sup>)</b>	-	47665	1371

S1 = scenario 1  
S2 = scenario 2

#### 3.5.2 Frequency and volume in the future

The distribution of the number of days, timesteps, and volume from the simulations that were run on the future timeseries for scenarios 1 and 2 can be seen in the boxplot in Figure 14. There is a notable difference in both frequency and volume for the two correction factors, and there is a reduction between scenarios 1 and 2 for both frequency and volume.

In the plot for the number of days with CSO events, scenario 1, C1 had a mean of 129 days, while the mean for scenario 2, C1 was 114 days. For C2, scenario 1 the mean was 61 days, while scenario 2 had a mean of 53 days. The reduction of the mean value of the number of days with active CSO was 12% for correction factor C1 and 6% for C2.

For the number of timesteps with CSO activation, C1 had a mean of 3009 times for scenario 1 and 2567 times for scenario 2. C2 had a mean of 847 timesteps for scenario 1 and 642 timesteps for scenario 2. The mean number of timesteps was reduced by 15% for C1 and 24% for C2.

The mean volume exiting the CSO through the overflow for the future 5-year periods for correction factor C1 was 125309 m<sup>3</sup> for scenario 1 and 99126 m<sup>3</sup> for scenario 2. For C2, the mean volume was 17866 m<sup>3</sup> for scenario 1 and 12886 m<sup>3</sup> for scenario 2. The mean volume was reduced by 21% when implementing BRC and correction factor C1, while the reduction for C2 was 28%.



Days and timesteps with active CSO and the volume to Nidelva river for future 5-year timeseries

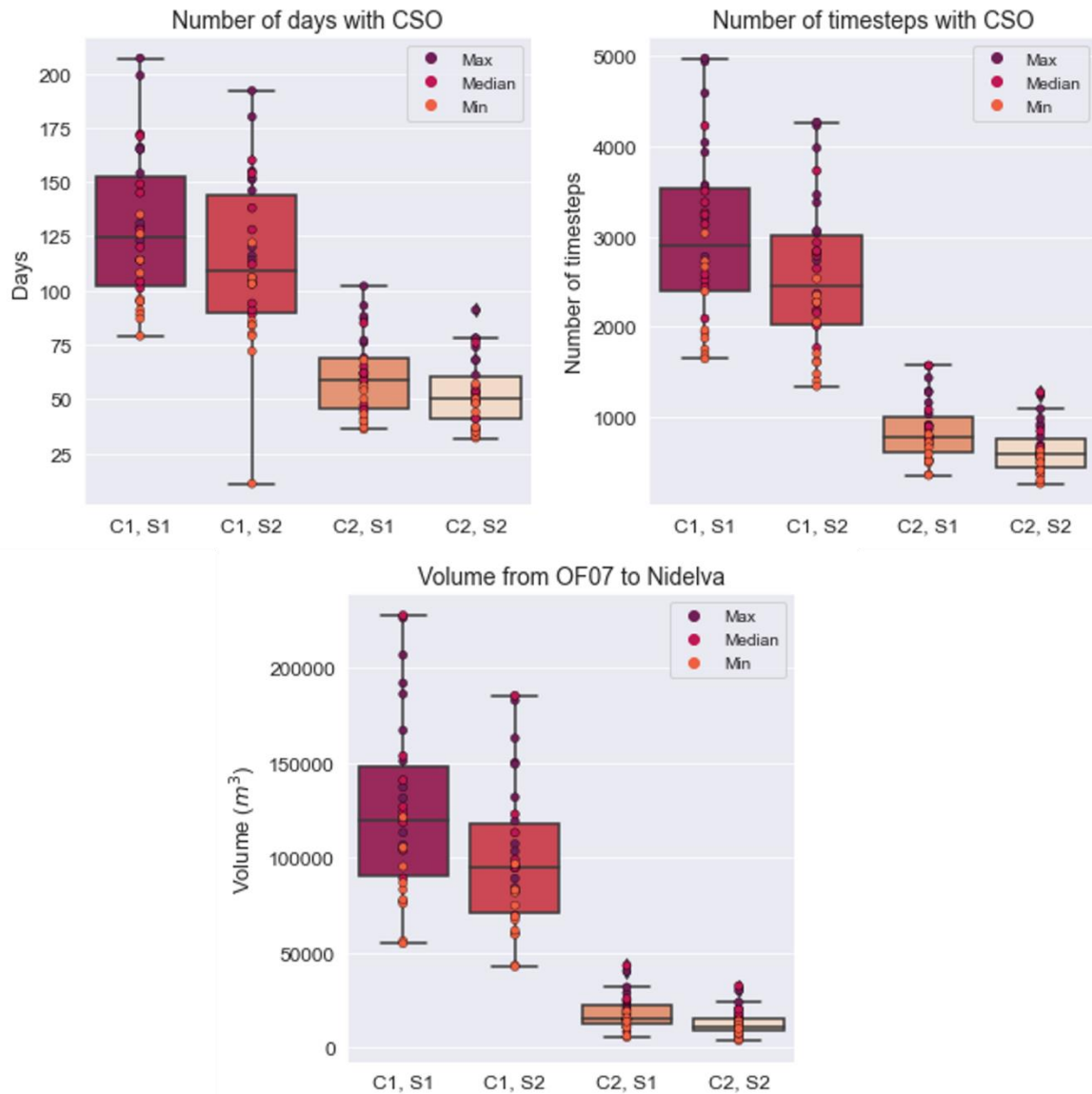

**Figure 14:** Boxplot (25-75 percentile) displaying the variation in results for analysis of days with CSO events, number of timesteps with CSO events (duration), and the 5-year volume from OF07 directly to Nidelva River for the thirty future 5-year timeseries. The scatterplots show the result for each of the thirty timeseries (maximum, median, and minimum precipitation scenarios) for the given correction factor (C1 and C2) and scenarios with and without SUDS (S1, S2).

### 3.6. Activation frequency using depth duration curves

#### 3.6.1 Historical depth duration curve

The analysis of the depth duration curves for the historical dataset shows that there was a reduction in the occurrence of CSOs between scenario 1 (do-nothing, no SUDS) and scenario 2 (with SUDS).

The occurrence of CSO events was reduced from scenario 1 to scenario 2 for both correction factors. For C1, the occurrence of water levels activating the CSO was reduced by 18.6%, which corresponds to 34 hours. For C1, the frequency of CSO events in both scenarios was significantly higher than the observed frequency. The difference between scenario 1 for C2 and observed values was zero due to the correction factor C2 being optimized to match the number

of timesteps in the observed dataset. When using C2, the reduction was 15 hours (34.9%). The results from the analysis can be seen in Table 9 and Figure 15.

**Table 9:** Hours with CSO activation for the historical timeseries. Results for scenarios 1 and 2 for C1 and C2, as well as the reduction between the scenarios.

	Observed	C1	C2
<b>Scenario 1 (hr)</b>	43	183	43
<b>Scenario 2 (hr)</b>	-	149	28
<b>Reduction (%)</b>	-	18.6 %	34.9 %

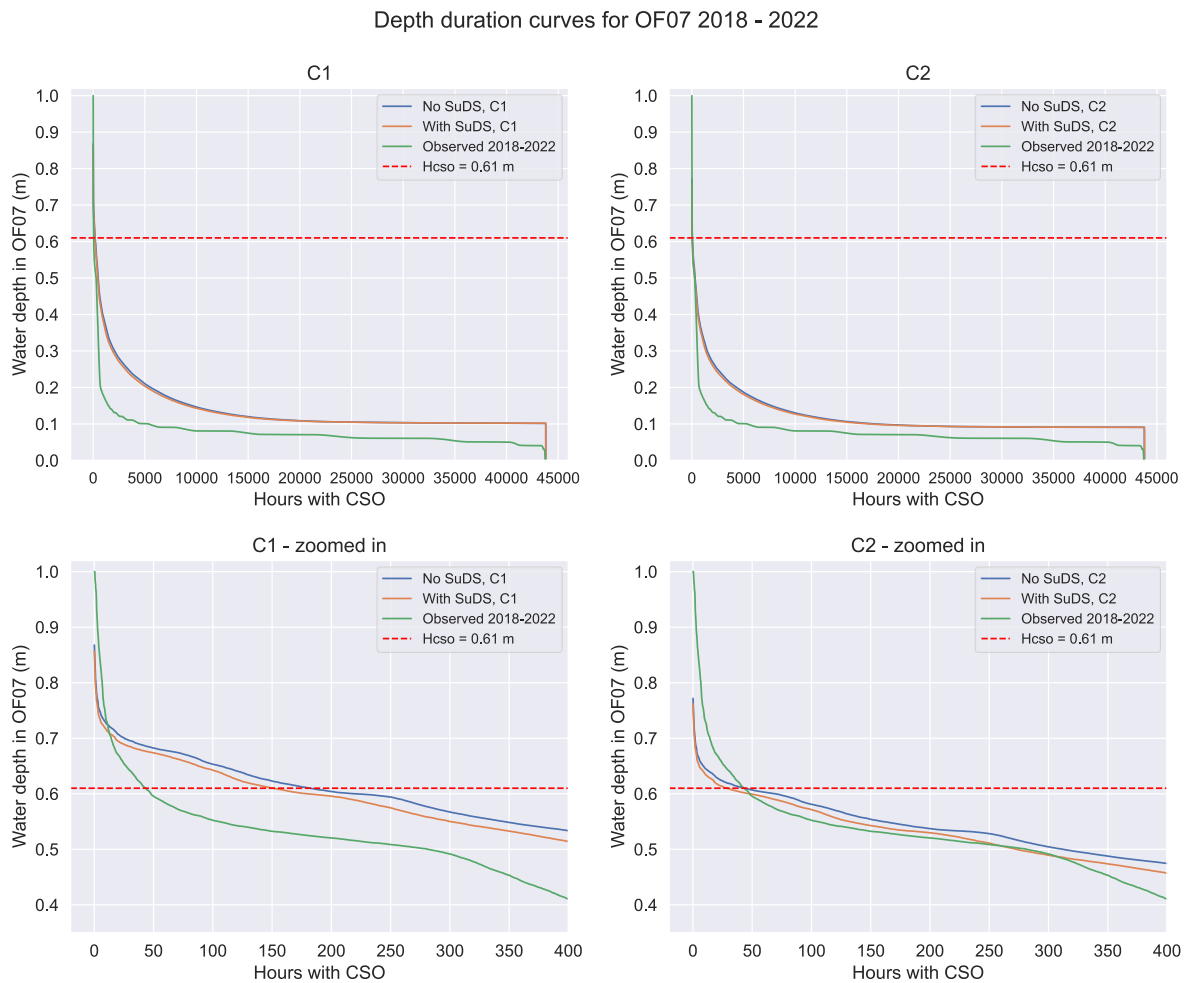

**Figure 15:** Depth duration curve for historical timeseries for scenarios with and without SUDS and correction factors C1 and C2. Hcso shows the threshold for CSO activation. The graph describes the number of hours in the 5-year period in which the water level was at certain height.

### 3.6.1 Future depth duration curve

For the future datasets, the scenario 1 water levels for correction factor C1 have a spread of 285 hours with a mean of 297 hours of active CSO for the period, whereas scenario 2 has a spread of 256 hours and a mean of 244 hours. For correction factor C2, the spread is 102 hours for scenario 1 and 78 hours for scenario 2. There was a reduction in active hours with the implementation of BRC (scenario 2) for both correction factors. The results can be seen in Table 10 and Figure 16.

**Table 10:** Hours with active CSO in future 5-year periods for scenarios 1 and 2, C1 and C2, as well as the reduction between the scenarios.

	C1			C2		
	5 <sup>th</sup> percentile	Mean	95 <sup>th</sup> percentile	5 <sup>th</sup> percentile	Mean	95 <sup>th</sup> percentile
<b>Scenario 1 (hr)</b>	170	297	455	43	81	145
<b>Scenario 2 (hr)</b>	140	244	396	35	63	113
<b>Reduction (%)</b>	17.6 %	17.8%	13.0%	22.2%	22.2%	22.1%

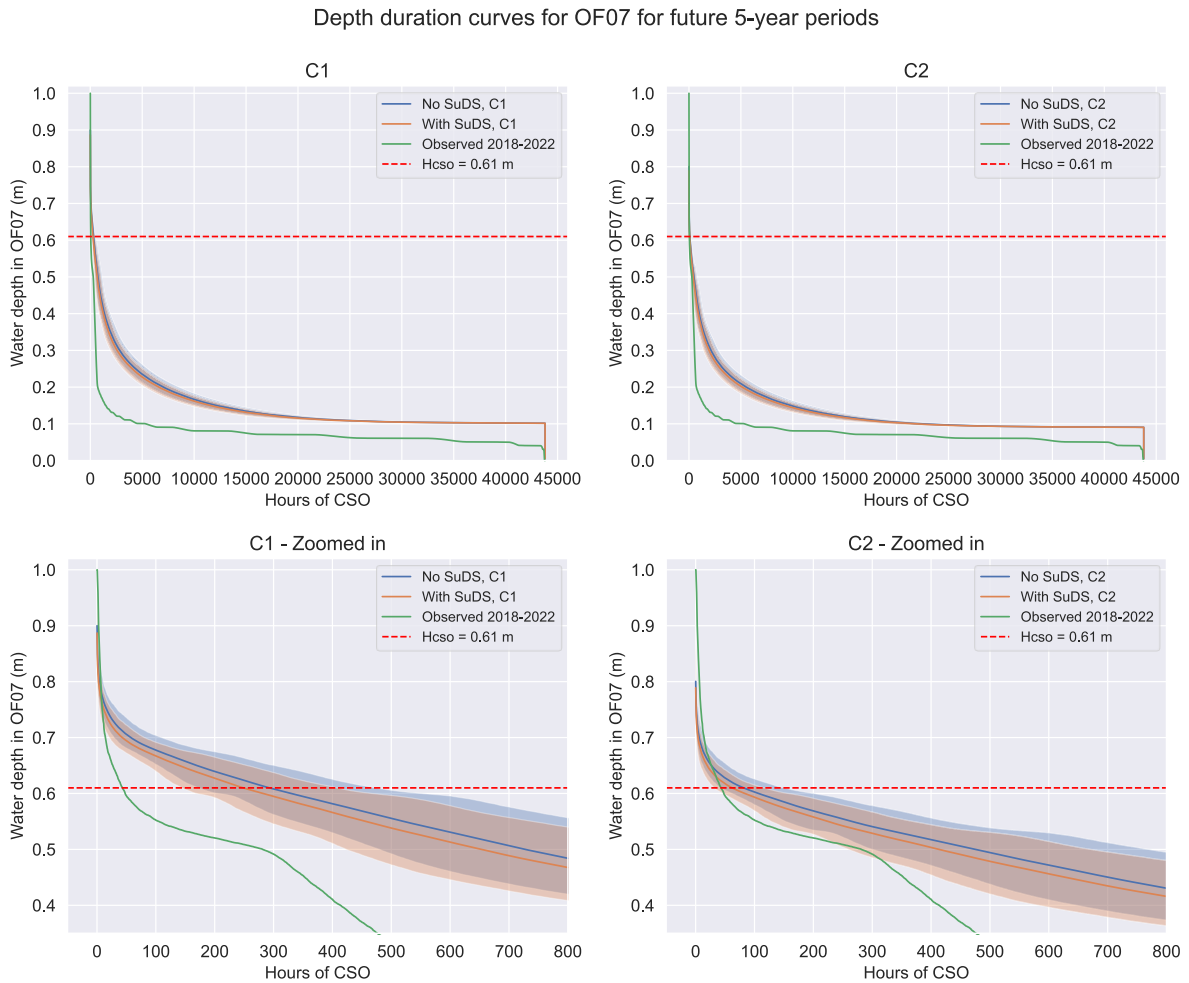

**Figure 16:** Depth duration curve for future 5-year periods for scenarios with and without SUDS and correction factors C1 and C2.  $H_{cso}$  shows the threshold for CSO activation. The graph describes the hours in the 5-year period with a certain water level. The future periods are presented as the mean of all thirty timeseries and with the 5<sup>th</sup> and 95<sup>th</sup> percentiles.

### 3.7. Needed surface are of bioretention cell

The implementation of BRC in 31% of the theoretically available area resulted in a BRC surface area equal to 14.9% of each sub-catchment area. The total surface area of BRC implemented in the project area was 20340 m<sup>2</sup>, and the precipitation for which the implemented BRC had capacity was 1.1 mm/hr (using Equation 4).

The BRC implemented in the SWMM model had a  $P_{design}$  which was only 39% of the precipitation which can be expected in Trondheim based on the historical precipitation dataset. The area of BRC implemented was about half the size (47%) of what is needed to manage the

current precipitation. Meanwhile, the future analysis shows that the design precipitation will be 65% higher than the current precipitation. The area needed in the future will be 71559 m<sup>2</sup>, which corresponds to 109% of the theoretically available area, since the available area is 65479 m<sup>2</sup>. The results from the calculations can be seen in Table 11.

**Table 11:** Design precipitation and BRC area needed correspondingly.

	Area (m <sup>2</sup> )	P <sub>design</sub> (mm/hr)
<b>BRC implemented in SWMM</b>	20340	1.1
<b>BRC 2018-2022</b>	43246	2.9
<b>BRC future</b>	71559	4.8

### 3.8. Seasonal variation

The analysis of the seasonal variation shows that a majority of the overflows occur during the summer and fall for both observed overflows and future simulated overflows. The largest CSO events occur in the fall. In the future timeseries, days with CSO events are more frequent during the winter than in the observed timeseries. The overall number of days has increased by 63%, from 70 days between 2018 and November 2022 to 114 days for the modeled data for 2090 to 2094. In the future, CSO events in the spring seem to only occur every other year, however, with higher frequency and duration in the years where spring activations do occur.

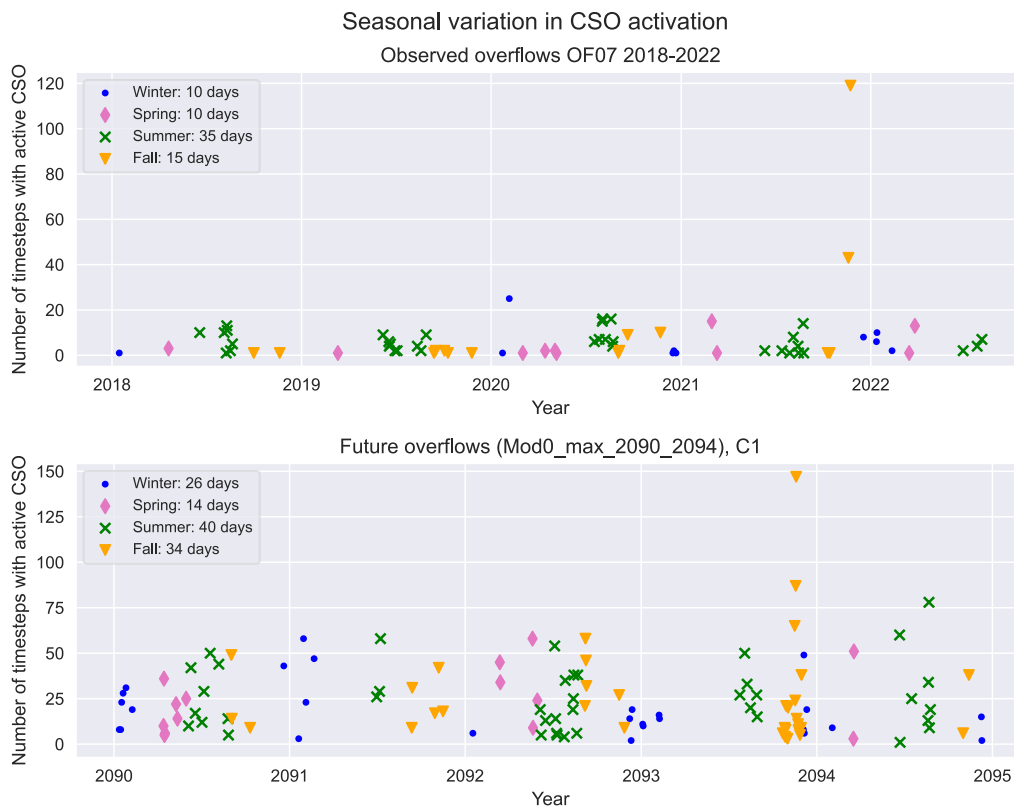

**Figure 17:** Seasonal distribution in CSO activation. Each point represents a date on which a number of timesteps with CSO activation occur. Note that the range of the y-axis of the plots is unequal.

### **3.9. Volume entering the combined sewer system**

The calculation of the volume entering the sewer system showed that the implementation of 20340 m<sup>2</sup> of BRC, corresponding to 31% of the theoretical available area, gives a reduction of 615 m<sup>3</sup> in the period 01.01.2018 to 31.11.2022. For the future periods, the reduction was 738 m<sup>3</sup> for all timeseries for the same area of BRC. This is the total reduction of water entering the chamber in OF07, not the reduction in water which flows over the weir.

## 4. Discussion

### 4.1. Calibration and correction factors

The calibration of the model was done focusing on the parameters in Table 2. Parameter set 1 (Table 5) was chosen based on the best performance according to NSE. A NSE of 0.338 is on the lower end of the scale for what is considered a good calibration result (Houshmand Kouchi et al., 2017). However, due to the high temporal resolution, the number of calibrated parameters, and the level of detail in the model, a perfect fit was unlikely to be achieved. Due to restricted time and the computational time of the calibration runs, only two calibrations were done, and the calibration with the highest NSE was chosen. A visual analysis of Figure 11 shows that the simulation captures the shape of the observed water levels well, however, that all values were underestimated. Correction factors C1 and C2 were used to account for the underestimations in the simulation.

Validation run 5 showed a higher NSE (0.359) for the period 2018 – November 2022 than the calibration NSE. A similar calibration was done in Le Floch et al. (2022) for a raingarden at Risvollan, Trondheim, however, ensemble parameter sets were used. The results from the calibration using KGE were satisfactory, however, the model performance decreased during the validation with KGE as low as 0.154. The calibration of the SWMM model resulted in NSE values with only a difference of 0.01 between the calibration and the validation of the 5-year period. This indicates that the model's consistency is sufficient for longer simulation periods, even though the model does not replicate the observed data perfectly.

Contrary to, for instance, Hernes et al. (2020), Barco et al. (2008), and Temprano et al. (2006), the percentage of impervious cover was not calibrated. Changing the ratio of pervious to impervious area is a way to increase performance regarding objective functions. However, by not changing the physical properties of the sub-catchments, the simulations are assumed to better replicate reality and thereby better show the performance of the implemented SUDS.

Even though the calibration result was accepted, multiple other adjustments could be made to increase the goodness-of-fit.

First, more parameters could have been included in the calibration. For instance, could the energy loss coefficient and the exit loss coefficient of the conduits have been calibrated and applied instead of being left at default. The water balance calculation shows that the difference in volume of water entering and exiting the system is small enough to correspond to the infiltration into the ground. The simulated water level in the weir OF07, is on the other hand, much lower than the observed level, leading one to believe that the velocity in the pipes is unrealistically high. Including the energy loss coefficient and the exit loss coefficient could decrease the energy of the water and lower the velocity, leading to an increase in the water level in the weir. The issue with including more parameters is the risk of overfitting the model (Belkin et al., 2019) or issues regarding the identifiability of the parameters (Guillaume et al., 2019). Both lead to higher uncertainties regarding the calibrated parameter set.

Secondly, the upper bond of Manning's number,  $n$ , in the pipes could be increased in the calibration. The pipes in the system are old (Trondheim Municipality, 2022a), which means that there is a high chance of broken and clogged pipes. Irregularities in the pipe structure lead to higher friction in the pipe, which can be described through the Manning's friction coefficient (number),  $n$  (King, 1918). Increased friction decreases the velocity of the water and increase

the water level. Another factor which has not been included in the model is the leakage of foreign water into the system. This was not included even though it is a part of the observed water levels from OF07 again due to the age and standard of the sewer system. (Trondheim Municipality, 2014)

The results from the calibration show that the Manning's number for impervious areas is higher than for pervious areas. The calibrated  $n$  for impervious areas should have had a higher bond due to most of the impervious areas being roofs. It is unlikely that the pervious areas have less friction than the roofs. Due to the high number of calibrated parameters, it is likely that some parameters compensate for others. The bounds for impervious and pervious areas could have been made different to account for the low roughness of roofs. In addition, several parameter sets can give the same NSE with relatively large differences in individual parameter values. Some parameter values might be unrealistic, even with NSE values indicating a good fit between the model and the observation. This results in a problem of equifinality in the model, which can already be seen for the parameters used through the differences in parameter sets 1 and 2.

Thirdly, the observed precipitation used in the simulations was taken from the nearest metrological station, which is at Lade. Due to the local rain intensity in Trondheim, the precipitation used in the simulation does not match the actual precipitation that generated the observed water levels. Especially the precipitation entering the system the furthest upstream in the drainage area of OF07 would be sensitive to the distance. This part is also located at a higher elevation than the rain gauge at Lade. For future projects, one solution is to station a temporary precipitation gauge in the project area for more accurate measurements. The same applies for the future modeled precipitation series, which are based on the rain gauge at Risvollan.

Ideally, the calibration should have been done for longer timeseries and/or for timeseries with larger precipitation events. The issue with using longer timeseries is that NSE uses the observed mean as a baseline, which can result in overestimation of parameters due to highly seasonal factors such as snowmelt (Gupta et al., 2009).

The volume differs the most from what was observed for correction factor C2, where it was significantly underestimated. For C1, on the other hand, the volume was overestimated. None of the two correction factors accounted for the volume in the system, however, the focus was on replicating the frequency of CSO activation, both in terms of the number of days and the duration of activation. A third correction factor could have been investigated to address the volume calculations. For this, an optimization function using Kling-Gupta Efficiency would have been a natural choice due to its ability to replicate the shape of data and therefore the volume.

#### **4.2. Using future climate-modeled precipitation data**

Originally, the future precipitation datasets consisted of one-hundred simulated timeseries with thirty years of data in simulation. The number of simulated timeseries was made to account for the high uncertainty in modeling future precipitation. As a consequence of only using a subset of the one-hundred simulated timeseries, the uncertainty regarding the analysis using the data increases. However, to replicate a wider range of possible future scenarios, the maximum, median, and minimum periods from all the models were extracted. As can be seen in the depth duration curve for the future events in Figure 16, there is a wide range of outcomes for number

of hours the water level is above the threshold for CSO activation. This replicates the uncertainty of using modeled data for future precipitation but also clearly shows the importance of running timeseries representing the whole range of future precipitation scenarios.

Further, the timeseries were chosen based on the sum of precipitation for each 5-year period rather than on the period. This means that the starting year of the future precipitation timeseries used for simulations varies from 2070 to 2095. By doing so, it is assumed that the timeseries for all periods are comparable, which further increases the span of outcomes in the analysis. Another option could have been to choose the same 5-year period for all models, however, there is a risk of loss of range of precipitation peaks due to the randomness of the modeled data. By using this method, it would be possible that the period could reflect lower or higher precipitation volumes than the rest of the datasets. To account for this, more datasets from more of the simulations could be introduced, however, then a new selection process would have to be conducted.

### **4.3. Effects of future precipitation on CSO operation and its risks**

The results in Section 3.5 show that future CSO events will increase both in frequency and volume. Petrie (2021) reviews CSO as a source of emerging contaminants and their effect on recipients. Emerging contaminants could be pharmaceuticals, illicit drugs, and personal care products (Rosenfeld & Feng, 2011), which are transported with the wastewater. The paper concludes that the effect of the pollution is highly local to the sites studied. Hence, it is fair to conclude that as long as no research is performed, the effect of CSO discharge to the Nidelva River and the Trondheim Fjord is unknown. The increase in frequency and volume is a concern because of the known negative effects on the ecology of the recipients, whether they are chronic or acute expositor to polluted water. As a result, the discharge of untreated wastewater should be managed with a precautionary approach. The future scenario simulations show clearly that there will be a need for more alternative solutions for stormwater management than the traditional combined sewers if the frequency and volume are to be reduced. This is also suggested in Petrie (2021) as a mitigation against emerging contaminants.

In addition to the risk regarding the ecology of the recipient, there is the risk of human exposure to untreated wastewater. As stated in Section 1.1, there is an increase in interest in using water bodies near cities for recreation, such as bathing. The increase in CSO events, together with the increase in human contact with the water bodies, increases the risk of health issues caused by microbials or chemicals associated with wastewater. The seasonal variation (Figure 17) shows that most days with CSO events currently occur in the summer and fall. The future simulation shows the same trend. This shows an overlap with the season for enjoying a bath in the otherwise cold Nordic climate and the highest frequency of CSO events. This adds to the urgency to address this problem by the municipality.

Even though most CSO events occur during the summer and fall, the highest increase in frequency in the future is for the winter season. This is assumed to be due to the ongoing increase in temperatures during the winter season (*Klima i Norge, Rapport KSS, 2015*). The temperature increase will result in more precipitation falling as rain instead of snow, causing increased runoff volumes. Additionally, more frequent snow melts will cause larger runoff events during the winter with high intensities and increased volumes. The frequency of spring



CSO events is shown to increase less than in other seasons, most likely because of the lack of snow which historically has melted during this period.

#### **4.1. Retrofit of the urban catchment at Lademoen**

The increase in CSO events leads to an increase in the area needed for alternative solutions such as bioretention cells or other infiltration-based solutions. The BRC area analysis using design precipitation events, assuming  $P_{\text{design}}$  equals to a 90% threshold event of the yearly volume, suggests a larger area than what is theoretically available is needed for the retrofit solution. The area that is considered available is the sum of all single areas. It is unreasonable to assume that each of the individual areas has the size required for BRC. One “of-the-shelf” raingarden is the [Alma raingarden](#), for which the smallest size is 1.22 m<sup>2</sup>. In addition to the size of the raingarden, there are requirements for distance to constructions such as buildings with cellars (Paus & Braskerud, 2013). This causes the available area for BRC to be narrowed down even more.

For the retrofit to be possible on a scale that has an effect, it should be investigated to increase the permeability of the entire project area. This implies that areas such as roads, parking spaces, and roofs also need to be able to retain or detain stormwater. By including paved areas through the use of permeable surfaces, the potential area for water retention and detention increases. In Lademoen Kirkeallé, the nearby roof drains have been connected to a separate underground system where the water is led to newly planted trees. Such solutions help reduce the load on the sewer system as well as being spatially effective.

It should be recognized that implementing BRC in 31% of the theoretically available area is on the upper range of what is realistic. Retrofitting the urban catchment at Lademoen is not realistic without strong collaboration between the municipality and the local community. Public spaces and private gardens, as well as parking spaces along the roads, need to be sacrificed to obtain the needed area for stormwater management through SUDS. Simulations for scenario 2, where the area of BRC is equal to 31% of the theoretically available area, show that the BRCs are not sufficient to manage the precipitation which is expected in current climate for Trondheim, let alone in the future. These measures for stormwater management not only have a positive impact on the reduction of CSO events but also reduce the risks connected with pluvial flooding. Additionally, a benefit that can be noted is the incorporation of more greenery in the urbanized area, improving the wellbeing of its inhabitants (Russo & Cirella, 2018).

The three-step strategy must be a trivial part of the planning process when establishing new urban areas. Urban planners, architects, contractors, and developers must all have a mutual understanding of the importance of stormwater management and which solutions exist for all steps in the three-step strategy. If stormwater management is included in the initial planning, costly retrofits can be avoided in the future, and the risks connected to untreated wastewater can be avoided.

#### **4.2. The role of step 1 solutions**

Lindholm (2018) defines step 1 solutions for stormwater management as precipitation events smaller than 20 mm, which is based on a precipitation event with a 20-year return period and a duration of 15 minutes in Oslo. Lindholm states that a 20-year return period is a design criterion used by some municipalities. The issue with this definition is that a return period of 20 years in the future will occur every five to ten years (Klimaservicesenter, 2023). It is

therefore important to use the climate factors suggested when designing SUDS as step 1 solutions.

Step 1 aims to collect, clean, and infiltrate stormwater from everyday events, however, we need to acknowledge that what is now a rare occasion might be an everyday event in the future. The report *Klima i Norge (Rapport KSS, 2015)* states that the possibility of the climate models underestimating the increase in precipitation cannot be excluded. Therefore, one might have to consider to what extent step 1 and 2 solutions for stormwater management are sufficient and if the present tolerance for activation of step 3 solutions must be increased to match the challenging forecasts. The report implies that activation of step 3 will happen more frequently, which also has implications for street management and parking restrictions.

Even though the temperatures are expected to increase in the future, there will still be periods of frozen ground and snow accumulation during the winter months (*Klima i Norge, Rapport KSS, 2015*). Hence, it is important that the chosen step 2 solutions are built for winter conditions with higher infiltration capacities (Paus et al., 2016). For this reason, hybrid systems with both green and gray solutions may be solutions which can add more flexibility to avoid major CSO events or pluvial flooding due to a breach of capacity in the sewer system.

## 5. Conclusion

This thesis examines the effect of the implementation of bioretention cells on the operation of combined sewer overflows. A project area at Lademoen, Trondheim and the CSO OF07 Biskop Grimkjells gate have been used in the case study.

A SWMM model was built based on a pre-existing MIKE+ model and properties found using QGIS. Thereafter, the model was calibrated for eight parameters for sub-catchment surfaces and pipe properties. The results from the calibrated model gave simulation results that replicated the observed water levels in OF07 in shape but underestimated the magnitude of the peaks. Therefore, correction factors optimized to match the number of days with CSO activation and time steps with CSO activation were found. The result using correction factors was datasets which replicated the number of days and timesteps well, however produced unrealistic results for volume exiting the CSO to the recipient.

Simulations were run for historical and future climate-modeled precipitation timeseries for scenarios with and without bioretention cells as SUDS. The simulation results show that the implementation of bioretention cells on 31% of the theoretically available area decreased both the hours with CSO and the volume which was emitted untreated. Additionally, there was a reduction in water entering the sewer system. The area implemented was on the upper range of what is realistic, still it is only half of the area needed to capture the precipitation that can currently be expected.

The estimated future design precipitation demands areas greater than what is theoretically available in the project area. Hence, we must expand our toolbox beyond bioretention cells and look at other solutions to reach our goals. These could include permeable pavements and green roofs, in addition to hybrid systems that address stormwater detention, particularly during the winter season.

## References

- Barco, J., Wong, K. M., & Stenstrom, M. K. (2008). Automatic Calibration of the U.S. EPA SWMM Model for a Large Urban Catchment. *Journal of Hydraulic Engineering*, 134(4), 466–474. [https://doi.org/10.1061/\(ASCE\)0733-9429\(2008\)134:4\(466\)](https://doi.org/10.1061/(ASCE)0733-9429(2008)134:4(466))
- Belkin, M., Hsu, D., Ma, S., & Mandal, S. (2019). Reconciling modern machine learning practice and the bias-variance trade-off. *Proceedings of the National Academy of Sciences*, 116(32), 15849–15854. <https://doi.org/10.1073/pnas.1903070116>
- Bennett, N. D., Croke, B. F. W., Guariso, G., Guillaume, J. H. A., Hamilton, S. H., Jakeman, A. J., Marsili-Libelli, S., Newham, L. T. H., Norton, J. P., Perrin, C., Pierce, S. A., Robson, B., Seppelt, R., Voinov, A. A., Fath, B. D., & Andreassian, V. (2013). Characterising performance of environmental models. *Environmental Modelling & Software*, 40, 1–20. <https://doi.org/10.1016/j.envsoft.2012.09.011>
- Butler, D., Digman, C., Makropoulos, C., & Davies, J. W. (2018). *Urban drainage*. CRC Press, Taylor & Francis.
- Chui, T. F. M., Liu, X., & Zhan, W. (2016). Assessing cost-effectiveness of specific LID practice designs in response to large storm events. *Journal of Hydrology*, 533, 353–364. <https://doi.org/10.1016/j.jhydrol.2015.12.011>
- DHI. (2023). *MIKE+ Model Manager*.
- Eiksund, S. (2023, February 24). *person equivalents in Møllenberg sewage zone—Eiksund* [Personal communication].
- EU ENV. (2022). *Proposal for a Directive concerning urban wastewater treatment (recast)*, Directorate-General for Environment.
- European Commission. (n.d.). *European Commission: Nature-based solutions*. Retrieved December 5, 2022, from [https://research-and-innovation.ec.europa.eu/research-area/environment/nature-based-solutions\\_en](https://research-and-innovation.ec.europa.eu/research-area/environment/nature-based-solutions_en)
- Fed. Aviation Agency. (1970). *AIRPORT DRAINAGE*. FEDERAL AVIATION ADMINISTRATION.
- Frantzeskaki, N. (2019). Seven lessons for planning nature-based solutions in cities. *Environmental Science & Policy*, 93, 101–111. <https://doi.org/10.1016/j.envsci.2018.12.033>
- Guillaume, J. H. A., Jakeman, J. D., Marsili-Libelli, S., Asher, M., Brunner, P., Croke, B., Hill, M. C., Jakeman, A. J., Keesman, K. J., Razavi, S., & Stigter, J. D. (2019). Introductory overview of identifiability analysis: A guide to evaluating whether you have the right type of data for your modeling purpose. *Environmental Modelling & Software*, 119, 418–432. <https://doi.org/10.1016/j.envsoft.2019.07.007>
- Gupta, H. V., Kling, H., Yilmaz, K. K., & Martinez, G. F. (2009). Decomposition of the mean squared error and NSE performance criteria: Implications for improving hydrological modelling. *Journal of Hydrology*, 377(1), 80–91. <https://doi.org/10.1016/j.jhydrol.2009.08.003>
- Hatt, B. E., Fletcher, T. D., & Deletic, A. (2009). Hydrologic and pollutant removal performance of stormwater biofiltration systems at the field scale. *Journal of Hydrology*, 365(3), 310–321. <https://doi.org/10.1016/j.jhydrol.2008.12.001>
- Hernes, R. R. (2018). *Evaluating Hydrological Performance of LID-Modules in Mike Urban*.
- Hernes, R. R., Gragne, A. S., Abdalla, E. M. H., Braskerud, B. C., Alfredsen, K., & Muthanna, T. M. (2020). Assessing the effects of four SUDS scenarios on combined sewer overflows in Oslo, Norway: Evaluating the low-impact development module of the Mike Urban model. *Hydrology Research*, 51(6), 1437–1454. <https://doi.org/10.2166/nh.2020.070>
- Houshmand Kouchi, D., Esmaili, K., Farid, A., Sanaeinejad, S. H., Khalili, D., & Mikayilov, F. (2017). Sensitivity of Calibrated Parameters and Water Resource Estimates on Different Objective Functions and Optimization Algorithms. *Water*, 9, 384. <https://doi.org/10.3390/w9060384>
- King, H. W. (1918). *Handbook of hydraulics—For the solution of the hydraulic problems*.
- Klima i Norge, Rapport KSS. (2015). <https://klimaservicesenter.no/kss/rapporter/kin2100>
- Klimaservicesenter. (2022). *Klimaprofil Sør-Trøndelag*. <https://klimaservicesenter.no/kss/klimaprofiler/sor-trondelag>
- Klimaservicesenter. (2023). *Nedbørintensitet (IVF-verdier)—Norsk klima service senter*. <https://klimaservicesenter.no/ivf?locale=nb&locationId=SN68050>
- Kulturminnesøk. (2022). *Kart—Kulturminnesøk*. <https://www.kulturminnesok.no/kart/>

- Kwok Wong, W., Haddeland, I., Lawrence, D., & Beldring, S. (2016). *Gridded 1 x1 km climate and hydrological projects for Norway*. Norwegian Water Resources and Energy Directorate.
- Le Floch, N., Pons, V., Hassan Abdalla, E. M., & Alfredsen, K. (2022). Catchment scale effects of low impact development implementation scenarios at different urbanization densities. *Journal of Hydrology*, 612, 128178. <https://doi.org/10.1016/j.jhydrol.2022.128178>
- Lindholm, O. (2018). *VA-Blad 125: Håndtering av overvann – LOD*. <https://www.va-blad.no/handtering-av-overvann-lod/>
- McCuen, R. H., Knight, Z., & Cutter, A. G. (2006). Evaluation of the Nash–Sutcliffe Efficiency Index. *Journal of Hydrologic Engineering*, 11(6), 597–602. [https://doi.org/10.1061/\(ASCE\)1084-0699\(2006\)11:6\(597\)](https://doi.org/10.1061/(ASCE)1084-0699(2006)11:6(597))
- Miljø Blad. (2007). *VA-blad 74*.
- NGU. (n.d.). *Løsmasser, infiltrasjonspotensiale*. Retrieved December 14, 2022, from <https://geo.ngu.no/kart/minkommune/>
- Paus, A. K. H. (2018). *Forslag til dimensjonerende verdier for trinn 1 i Norsk Vann sin tre-trinns strategi for håndtering av overvann*.
- Paus, K. H. (2018). *Tre-trinns strategien og dimensjonering i praksis*.
- Paus, K. H., & Braskerud, B. C. (2013). *Forslag til dimensjonering og utforming av regnbed for norske forhold*. 14.
- Paus, K. H., Muthanna, T. M., & Braskerud, B. C. (2015). The hydrological performance of bioretention cells in regions with cold climates: Seasonal variation and implications for design. *Hydrology Research*, 47(2), 291–304. <https://doi.org/10.2166/nh.2015.084>
- Paus, K. H., Muthanna, T. M., & Braskerud, B. C. (2016). The hydrological performance of bioretention cells in regions with cold climates: Seasonal variation and implications for design. *Hydrology Research*, 47(2), 291–304. <https://doi.org/10.2166/nh.2015.084>
- Petrie, B. (2021). A review of combined sewer overflows as a source of wastewater-derived emerging contaminants in the environment and their management. *Environmental Science and Pollution Research*, 28(25), 32095–32110. <https://doi.org/10.1007/s11356-021-14103-1>
- Pichler, Markus. (2022). *swmm-api: API for reading, manipulating and running SWMM-Projects with python* (0.3). Zenodo. <https://doi.org/10.5281/ZENODO.7054804>
- Pons, V., Benestad, R., Sivertsen, E., Muthanna, T. M., & Bertrand-Krajewski, J.-L. (2022). Forecasting green roof detention performance by temporal downscaling of precipitation time-series projections. *Hydrology and Earth System Sciences*, 26(11), 2855–2874. <https://doi.org/10.5194/hess-26-2855-2022>
- QGIS 3.22. (2022, March 12). *Documentation for QGIS 3.22—QGIS Documentation documentation*. <https://docs.qgis.org/3.22/en/docs/index.html>
- Rawls, W. J., Brakensiek, D. L., & Miller, N. (1983). Green-ampt Infiltration Parameters from Soils Data. *Journal of Hydraulic Engineering*, 109(1), 62–70. [https://doi.org/10.1061/\(ASCE\)0733-9429\(1983\)109:1\(62\)](https://doi.org/10.1061/(ASCE)0733-9429(1983)109:1(62))
- Ringnes, T., Benestad, R., Hammerstrøm, M., & Kristiansen, J. R. (2023). Årstider. In *Store norske leksikon*. <https://snl.no/%C3%A5rstider>
- Rosenfeld, P. E., & Feng, L. G. H. (2011). *Emerging Contaminant—An overview | ScienceDirect Topics*. <https://www.sciencedirect.com/topics/earth-and-planetary-sciences/emerging-contaminant>
- Rossmann, L. A. (2015). *Storm Water Management Model User's Manual Version 5.1*.
- Russo, A., & Cirella, G. T. (2018). Modern Compact Cities: How Much Greenery Do We Need? *International Journal of Environmental Research and Public Health*, 15(10), 2180. <https://doi.org/10.3390/ijerph15102180>
- RWTH. (2022). *StopUP*. <https://www.fb3.rwth-aachen.de/cms/bauingenieurwesen/Forschung/Projekte/~wcxll/Stop-urban-pollution-StopUP-Protecti/?lidx=1>
- Saksfremlegg. (2021, October 3). Trondheim kommune. <https://www.trondheim.kommune.no/aktuelt/om-kommunen/annet/prosjekter-fra-a-a/omradesatsinger-i-trondheim/lademoen/>
- Stiftelsen VA/Miljø-blad. (2023). *VA/Miljø-blad stiftelsen: VA-Miljø*. <https://www.va-blad.no/vamiljo-blad-stiftelsen/>

- StopUP. (2021). *Protecting the aquatic environment from urban runoff pollution “StopUP.”*
- Storn, R., & Price, K. (1997). Differential Evolution – A Simple and Efficient Heuristic for Global Optimization over Continuous Spaces. *Journal of Global Optimization*, 11(4), 341–359. <https://doi.org/10.1023/A:1008202821328>
- swmmio. (2023, May 19). *swmmio—Swmmio 0.6.7 documentation*. <https://swmmio.readthedocs.io/en/v0.6.7/>
- SWRCB. (2011). *Runoff Coefficient (C) Fact Sheet*. Waterboards Canada.
- Tek17. (n.d.). § 8-3. *Uteoppholdsareal*. Direktoratet for byggkvalitet. Retrieved May 10, 2023, from <https://dibk.no/regelverk/byggteknisk-forskrift-tek17/8/8-3>
- Temprano, J., Arango, O., & Cagiao, J. (2006). *Stormwater quality calibration by SWMM: A case study in Northern Spain*. <https://doi.org/10.10520/EJC116306>
- Trondheim Municipality. (2014). *Saneringsplan Møllenberg*.
- Trondheim Municipality. (2023). *Dreneringsomåde OF07 Biskop Grimkjells gate* [Map].
- Trondheim Municipality. (2022a). *Kommunedelplan Vann i Trondheim—13 Avløpssystemet*. <https://sites.google.com/trondheim.kommune.no/kdp-vann-i-trondheim/vedleggsrapport/13-avl%C3%B8pssystemet>
- Trondheim Municipality. (2022b, October 20). *Kommunedelplan Vann i Trondheim—Tilpasse til et klima i endring*. <https://sites.google.com/trondheim.kommune.no/kdp-vann-i-trondheim/tilpasse-til-et-klima-i-endring>
- Tscheikner-Gratl, F. (2022). *Urban Drainage Systems—Lecture in TVM4141 NTNU 2022*.
- US EPA, O. (2014, May 21). *Storm Water Management Model (SWMM)* [Data and Tools]. <https://www.epa.gov/water-research/storm-water-management-model-swmm>
- WEF, & EWRI (U.S.) (Eds.). (2012). *Design of urban stormwater controls* (2nd ed). McGraw-Hill Professional ; McGraw-Hill [distributor].
- Wien, C. R. (2022). *Retrofit of Urban Drainage Systems- A possibility study of Lademoen, Trondheim*.
- Wikipedia. (2022). WSUDS. In *Wikipedia*. [https://en.wikipedia.org/w/index.php?title=Water-sensitive\\_urban\\_design&oldid=1124488988](https://en.wikipedia.org/w/index.php?title=Water-sensitive_urban_design&oldid=1124488988)
- yr.no. (2021, December 18). *Historiske værddata for Lademoen som graf—18. Desember 2021*. Yr. <https://www.yr.no/nb/historikk/graf/1-2810161/Norge/Trøndelag/Trondheim/Lademoen?q=2021-12-18>

# Appendix

## A1 Geometry of OF07 Biskop Grimkjells gate

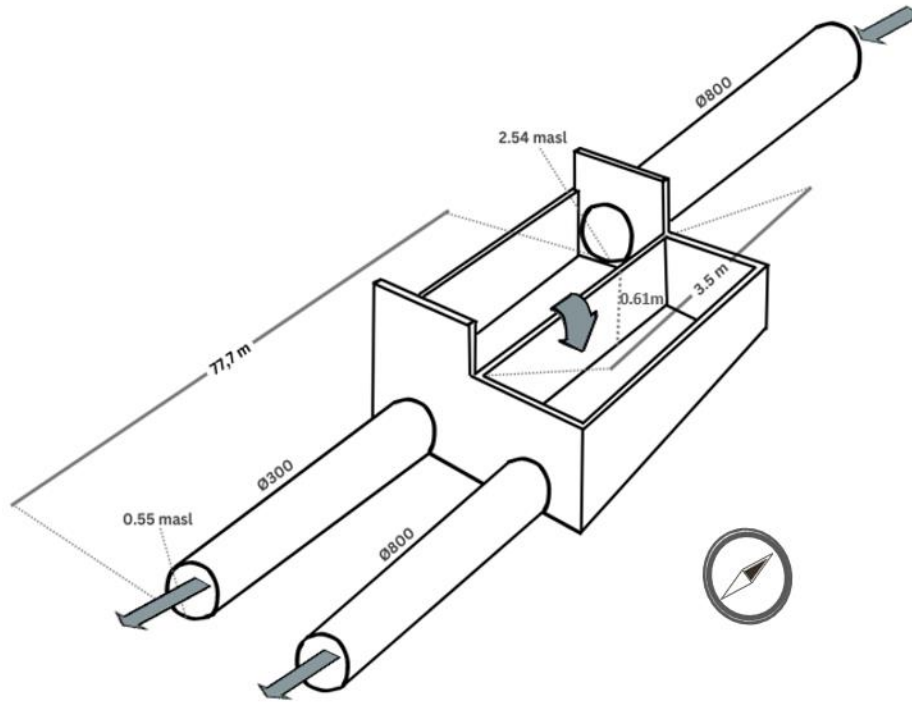

**Figure A1** Geometry of OF07 Biskop Grimkjells gate

## A2 Pictures from OF07 Biskop Grimkjells gate

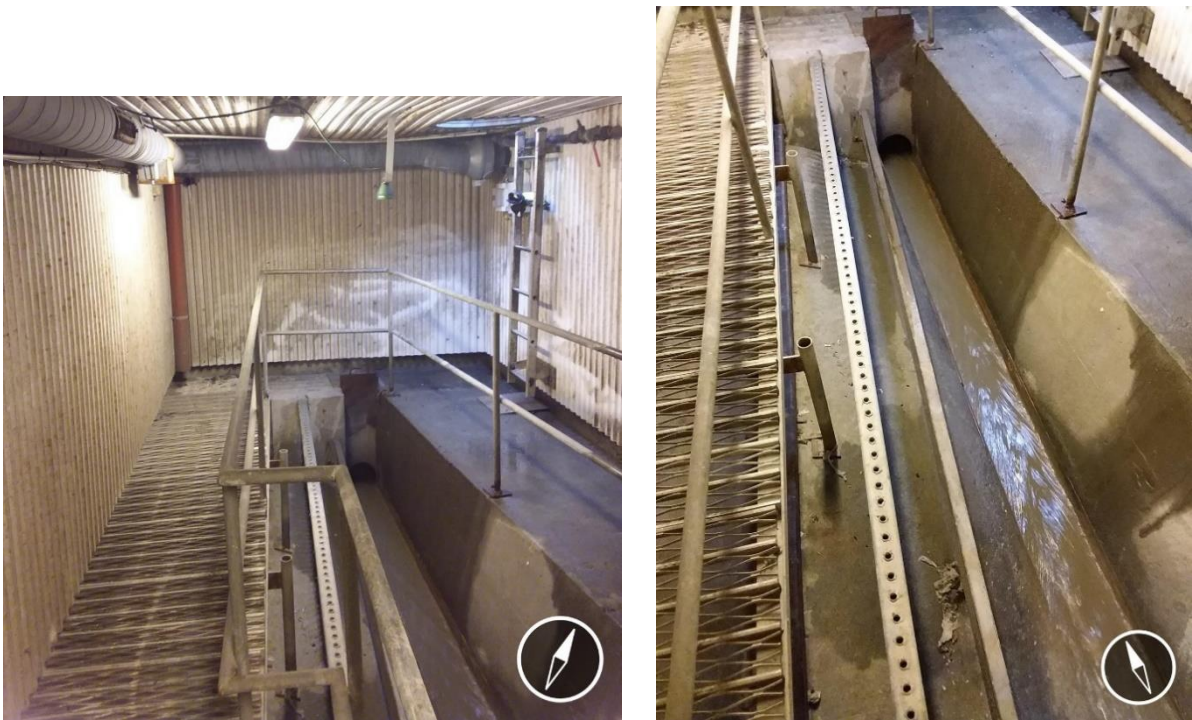

**Figure A2** Pictures from inside OF07. The outlet is located under the walkway to the left in the pictures.



## A3 Calibration of the SWMM model using Python (Code)

In [ ]:

```
from swmm_api import swmm5_run
import numpy as np
from scipy.optimize import differential_evolution, NonlinearConstraint, Bounds
import sys
import os
import tempfile
import matplotlib.pyplot as plt
from swmm_api import read_out_file
import pandas as pd
from swmm_api import read_inp_file, SwmmInput
from swmm_api.input_file.section_labels import JUNCTIONS, SUBCATCHMENTS, INFILTRATION, SUBAR
from swmm_api.input_file import read_inp_file, SwmmInput, section_labels as sections
from swmm_api.input_file.sections import Outfall
import random
import string
```

In [ ]:

```
#optimisation function - Nash-Sutcliffe efficiency
def NSE(sim, obs):
    return (1 - (np.sum((sim - obs)**2) / np.sum((obs - np.mean(obs))**2)))
```

In [ ]:

```
#importing swmm files
inp_file = r'C:\Users\cajsarw\OneDrive - NTNU\10.semester (Master)\SWMM\calib_folder\Cali
swmm_exe = r'C:\Program Files\EPA SWMM 5.2.1 (64-bit)\runswmm.exe'
```

In [ ]:

```
#Looking at precipitation TS and edits to datetime

df = pd.DataFrame(pd.read_csv(r'C:\Users\cajsarw\OneDrive - NTNU\10.semester (Master)\Sk
    sep=";", header=0))

df['Date'] = df['Unnamed: 0'] #change name of column
df['Date'] = pd.to_datetime(df['Date'], format='%d.%m.%Y %H:%M')
```

In [ ]:

```
'''Extracting data from only the period of interest. Saving the period in a new dataframe
and plotting the precipitation and the observed water levels for visual comparison.'''

starting1 = pd.to_datetime("16.06.2017 00:00", format='%d.%m.%Y %H:%M')
ending1 = pd.to_datetime("23.06.2017 00:00", format='%d.%m.%Y %H:%M')

mask = (df['Date'] > starting1) & (df['Date'] <= ending1)
df2 = df.loc[mask]

fig, ax = plt.subplots(2, 1, gridspec_kw={'height_ratios': [3,3]}, figsize=(10,5))

ax[0].plot(df2['Date'], df2['Precipitation mm/min'])
ax[0].set(xlabel='Date', ylabel='Precipitation')
ax[0].grid()

ax[1].plot(df2['Date'], df2['Water depth OV07'])
ax[1].set(xlabel='Date', ylabel='Water depth')
ax[1].grid()

plt.show()
```

In [ ]:

```
'''function for oprimalization of parameter set. The function takes in a range of paramet
adjustes the inp-file accordingly and calculates the NSE between the simulation resul
and the observed water levels in the calibration period. The function returns NSE-1 b
differential evolution is a minimalization optimizer.'''

def calib_function(param,obsWL, inp,calibFolder):
    #swmm_exe = r'C:\Program Files (x86)\EPA SWMM 5.2.3\runswmm.exe'
    for label, obj in inp[sections.INFILTRATION].items():
        inp[INFILTRATION][label].suction_head = param[0]
        inp[INFILTRATION][label].hydraulic_conductivity = param[1]

    for label, obj in inp[sections.SUBAREAS].items():
        inp[SUBAREAS][label].n_imperv = param[2] #manning
        inp[SUBAREAS][label].n_perv = param[3] #manning
        inp[SUBAREAS][label].storage_imperv = param[4]
        inp[SUBAREAS][label].storage_perv = param[5]

    for label, obj in inp[sections.CONDUITS].items():
        inp[CONDUITS][label].roughness = param[6] #roughness of pipes

    for label, obj in inp[sections.INFLOWS].items():
        inp[INFLOWS][label].base_value = param[7]

    temp_name = ''.join(random.choices(string.ascii_lowercase, k=5)) #generating a random
    temp_inp = calibFolder +temp_name + ".inp"
    temp_out = calibFolder +temp_name+ ".out"
    temp_rpt = calibFolder +temp_name + ".rpt"
    inp.write_file(temp_inp)
    swmm5_run(fn_inp = temp_inp,swmm_lib_path=swmm_exe, progress_size=100)
    out = read_out_file(temp_out) # type: swmm_api.SwmmOut
    df = out.to_frame() # type: pandas.DataFrame
    WL1 = df[('link', 'OV07', 'depth')]
    obs1 = obsWL.to_numpy()
    sim1 = WL1.to_numpy()
    NSE1 = NSE(sim1,obs1)
    out.close()
    os.remove(temp_inp) #delets files after calculation of nse
    os.remove(temp_out)
    os.remove(temp_rpt)
    print(NSE1)
    return(NSE1*-1)
```

In [ ]:

```
'''Function for running the swmm model with the optimized parameter set.
The function retuns the water level in OF07'''

def run_swmm(param, inp):

    for label, obj in inp[sections.INFILTRATION].items():
        inp[INFILTRATION][label].suction_head = param[0]
        inp[INFILTRATION][label].hydraulic_conductivity = param[1]

    for label, obj in inp[sections.SUBAREAS].items():
        inp[SUBAREAS][label].n_imperv = param[2]
        inp[SUBAREAS][label].n_perv = param[3]
        inp[SUBAREAS][label].storage_imperv = param[4]
        inp[SUBAREAS][label].storage_perv = param[5]

    for label, obj in inp[sections.CONDUITS].items():
        inp[CONDUITS][label].roughness = param[6]

    for label, obj in inp[sections.INFLOWS].items():
        inp[INFLOWS][label].base_value = param[7]

    temp_name = "calibrated_13.04.2023" #name
    temp_inp = calibFolder +temp_name + ".inp"
    temp_out = calibFolder +temp_name+ ".out"
    temp_rpt = calibFolder +temp_name + ".rpt"
    inp.write_file(temp_inp)
```

```

swmm5_run(fn_inp = temp_inp,swmm_lib_path=swmm_exe, progress_size=100)
out = read_out_file(temp_out) # type: swmm_api.SwmmOut
df = out.to_frame() # type: pandas.DataFrame
WL1 = df[['link', 'OV07', 'depth']]
return(WL1)

```

In [ ]:

```

#creating calib Folder

calibFolder = 'C:/Users/cajsarw/OneDrive - NTNU/10.semester (Master)/SWMM/calib_folder/ca

# need to rerun this to read the inp file
#inp_file = r'\Users\cajsarw\OneDrive - NTNU\10.semester (Master)\SWMM\SWMM_MODEL_final_M

```

In [ ]:

```

inp = read_inp_file(inp_file)
obsWL = df2['Water depth OV07']

#bounds = Bounds([1., 0., 0.01, 0.01,0., 0.,0.01,0],
#                #[100., 100.,0.3, 0.3,5., 5.,0.3,0.1]) #[min,max] for each of the 8 param

bounds = Bounds([1., 0., 0.01, 0.01,0., 0.,0.01],
                [100., 100.,0.3, 0.3,5., 5.,0.3]) #[min,max] for each of the 7 params, no

''' Returns a optimized parameter set found by differential evolution.'''
result = differential_evolution(calib_function, bounds,seed=0,maxiter=20,
                               args=(obsWL, inp,calibFolder)) #workers=-1)

```

In [ ]:

```

'''Viewing the calibration results'''
result

#param = result.x
#param

```

In [ ]:

```

#parameters from calibration 13.04.2023 (parameterset 2)
param = [39.02511236, 1.35695506, 0.28488882, 0.20771941, 2.64535341,
        3.0704638 , 0.13286695]

```

In [ ]:

```

#parameters from the previous calibration 08.04.2023 (parameterset 1)

param_2 = [9.47960663, 6.89311136*10**-1, 2.80292534*10**-1, 1.75636224*10**-1,6.62072037

inp_2_file = 'C:/Users/cajsarw/OneDrive - NTNU/10.semester (Master)/SWMM/calib_folder/Cal
inp_2 = read_inp_file(inp_2_file)

```

In [ ]:

```

WL2 = run_swmm(param_2, inp_2) #calibration 08.04.23
WL1 = run_swmm(param,inp) #calibration 13.04.23

```

In [ ]:

▶

```
'''Plotting the results from the simulation using parameter set 1 and 2 together with the
water levels in the same period. Printing the NSE.'''

fig, ax = plt.subplots(2, 1, figsize = (20,10))#gridspec_kw={'height_ratios': [5, 5]})

ax[0].plot(df2['Date'],df2['Precipitation mm/min'], label = 'Precipitation')
ax[0].set(xlabel='Date', ylabel='Precipitation')
ax[0].grid()
ax[0].legend()

ax[1].plot(df2['Date'],df2['Water depth OV07'], label = 'WL observed')
ax[1].set(xlabel='Date', ylabel='Water depth')
ax[1].legend()

obs1 = df2['Water depth OV07'].to_numpy()
sim1 = WL1.to_numpy() #calibration 13.04.23
sim2 = WL2.to_numpy() #calibration 08.04.23
NSE1 = NSE(sim1,obs1)
NSE2 = NSE(sim2,obs1)
print('NSE1 = ',NSE1)
print('NSE2 = ',NSE2)
print('Param = ',param)
print('Param_2 = ', param_2)

ax[1].plot(WL2, label = 'WL simulated 08.04.2023')
ax[1].legend()

ax[1].plot(WL1, label = 'WL simulated 13.04.2023')
ax[1].legend()

plt.axhline(y=0.61, xmin=0, xmax=1)

ax[1].grid()
plt.show()
```

## A4 Running the SWMM model using Python (Code)

This code was also edited to run for the *historical* events. By changing the inp-file to one with BRC implemented, this also works for *scenario 2* simulations. In my simulation I used a total of 4 of this type of code, altered to match historical scenario 1 and 2, and future scenario 1 and 2.

In [ ]:

```
from swmm_api import swmm5_run
import numpy as np
from scipy.optimize import differential_evolution, NonlinearConstraint, Bounds
import sys
import os
import tempfile
import matplotlib.pyplot as plt
from swmm_api import read_out_file
import pandas as pd
from swmm_api import read_inp_file, SwmmInput
from swmm_api.input_file.section_labels import JUNCTIONS, SUBCATCHMENTS, INFILTRATION, SUBAR
from swmm_api.input_file import read_inp_file, SwmmInput, section_labels as sections
from swmm_api.input_file.sections import Outfall
from swmm_api.input_file.section_labels import TIMESERIES
import string

import swmmio
from swmmio import Model

from swmm_api.input_file.sections import *
```

In [ ]:

```
'''reading the inp-file for the swmm model and calling the model m.'''

inp_file = r'C:\Users\cajsarw\OneDrive - NTNU\10.semester (Master)\SWMM\01_SWMM\Future\Sw
swmm_exe = r'C:\Program Files (x86)\EPA SWMM 5.2.3\runswmm.exe'

m = Model(inp_file)
```

In [ ]:

```
'''reading the inp-file for the swmm model and calling the model m.'''

inp_file = r'C:\Users\cajsarw\OneDrive - NTNU\10.semester (Master)\SWMM\01_SWMM\Future\Sw
swmm_exe = r'C:\Program Files (x86)\EPA SWMM 5.2.3\runswmm.exe'

m = Model(inp_file)
```

In [ ]:

```
'''Reading all files in a folder. The file-type in the name was removed to use the name f
inp-files and precipitation files (.dat).'''

folder_path = 'C:/Users/cajsarw/OneDrive - NTNU/10.semester (Master)/SWMM/02_Data/Max_mir
file_names = os.listdir(folder_path)
#print(file_names)

# remove the '.csv' extension from each filename
filenames_without_extension = [file_name.replace('.csv', '') for file_name in file_names]

# print the new filenames
#print(filenames_without_extension)
```

In [ ]:

```
'''The count selects the files which are in use. The precip-files in .dat and .csv are na

count = 0

#precipitation data
TS_name = filenames_without_extension[count]
filepath_TS_dat = 'C:/Users/cajsarw/OneDrive - NTNU/10.semester (Master)/SWMM/02_Data/Pre

#precip csv
filepath = 'C:/Users/cajsarw/OneDrive - NTNU/10.semester (Master)/SWMM/02_Data/Max_min_me
df = pd.read_csv(filepath, sep = ';')
```

```

#changing the formate of the date
date = pd.to_datetime(df.loc[:, 'Date'], format='%d.%m.%Y')
time = pd.to_datetime(df.loc[:, 'Time'], format = '%H:%M:%S')
date1 = date.dt.strftime('%m/%d/%Y')
time1 = date.dt.strftime('%H:%M')
df = pd.DataFrame({"date": date1, "time":time1, "precipitation": df.loc[:, "Precipitation"]})

```

In [ ]:

```

'''Changing the starting and ending times, and changing the precipitation timeseries file

```

```

#changing the dates
start_date = df['date'][0]
end_date = df['date'].iloc[-1] #Last date in time series

m.inp.options.loc['START_DATE', 'Value'] = str(start_date)
m.inp.options.loc['REPORT_START_DATE', 'Value'] = str(start_date)
m.inp.options.loc['END_DATE', 'Value'] = str(end_date)
#m.inp.options

#changing filepath to timeseries
m.inp.timeseries.loc['future', 'Value'] = filepath_TS_dat
#m.inp.timeseries

m.inp.save('C:/Users/cajsarw/OneDrive - NTNU/10.semester (Master)/SWMM/01_SWMM/Future/'+T

```

In [ ]:

```

#printing precipitation file path
m.inp.timeseries

```

In [ ]:

```

#reading the inpfile
inp_file = 'C:/Users/cajsarw/OneDrive - NTNU/10.semester (Master)/SWMM/01_SWMM/Future/'+T

inp = read_inp_file(inp_file)

def check_time(inp):
    """Check if the simulation time and the main timeseries are relevant. """
    options = inp.OPTIONS
    start = pd.to_datetime(options["START_DATE"])
    end = pd.to_datetime(options["END_DATE"])
    for rg in inp.RAINGAGES.items():
        ts_name = rg[1].timeseries
        filename = inp.TIMESERIES[ts_name].filename
        new_file = pd.read_csv(filename, delimiter = "\s+", header = None)
        start_in = pd.to_datetime(new_file.iloc[0,0], format = "%m/%d/%Y")
        end_in = pd.to_datetime(new_file.iloc[-1,0], format = "%m/%d/%Y")
        if start == start_in:
            if end == end_in:
                print("Options and time-series are aligned")
            if end < end_in:
                diff = end_in - end
                print(f"simulation stops {diff} after the end of input data")
            elif end > end_in:
                diff = end - end_in
                print(f"simulation stops {diff} before the end of input data")
                sim_length = end - start
                print(f"Simulation is {sim_length}")
        if end < start_in:
            print("No overlap between simulation and data")
        if start > end_in:
            print("No overlap between simulation and data")

        print('TS_name = ', ts_name)
        print('Start = ', start)
    return new_file

#checking that the inp-file has the right time series.
check_time(inp)

```

## A5 Optimization of correction factors (Code)

In [ ]:

```
import numpy as np
import pandas as pd
import matplotlib.pyplot as plt

from scipy.optimize import differential_evolution

import seaborn as sns
#plotting style
sns.set(style='darkgrid')
sns.set_context("paper")
color = sns.color_palette("rocket",10)
color
```

In [ ]:

```
'''reading datafile and converting timesteps to datetime format'''

df = pd.read_csv( r'C:\Users\cajsarw\OneDrive - NTNU\10.semester (Master)\SWMM\06_sim_res
sep=';',header=0)

df['Timestep'] = pd.to_datetime(df['Timestep'], format= '%d.%m.%Y %H:%M')
df['Date'] = df['Timestep'].dt.date

#df.set_index('Timestep', inplace=True)
```

In [ ]:

```
'''Define the objective function to minimize the difference in peaks above 0.61 in obs and
This code matchen the number of timesteps above the threshold line.'''

def objective_func(x, df):

    # Devide the 'sim' column by x[0]
    sim_corr = df['sim']/x[0]

    # Calculate the count of values above 0.61 in 'obs' and 'sim_corr'
    obs_count = np.sum(df['obs'] > 0.61)
    sim_corr_count = np.sum(sim_corr > 0.61)

    # Calculate the absolute difference in the counts
    count_diff = abs(obs_count - sim_corr_count)

    # Return the difference as the objective function to minimize
    return count_diff

# Define the bounds for the parameter to optimize
bounds = [(0, 1)]
```

In [ ]:

```
# Run differential evolution to find the optimal parameter
result = differential_evolution(objective_func, bounds, args=(df,))
optimal_param = result.x[0]

print(optimal_param)
```

In [ ]:

```
'''function which finds the correction factor to match the number of dates with CSOs '''

def objective_func_2(x, df):

    # Multiply the 'sim' column by x[0]
    df["sim_corr"] = df['sim']/x[0]

    df['obs_active'] = df['obs'] > 0.61
    df['active_CS0_base'] = df['sim_corr'] > 0.61

    obs_count = np.unique(df.loc[df.loc[:, "obs_active"], "Date"]).size
    sim_corr_count = np.unique(df.loc[df.loc[:, "active_CS0_base"], "Date"]).size
```

```

count_diff = abs(obs_count - sim_corr_count)
return count_diff

# Define the bounds for the parameter to optimize
bounds = [(0, 5)]

#print(objective_func_2([0.55], df))
# Run differential evolution to find the optimal parameter
result = differential_evolution(objective_func_2, bounds, args=(df,))
optimal_param_2 = result.x[0]

print(optimal_param_2)
print(objective_func_2([optimal_param_2], df))

```

In [ ]:

```

"""Using the optimal parameter to calculate the number of peaks above the weir threshold
of 0.61m for the simulated, corrected simulated and the observed dataset."""
#optimal_param = 0.5520854011107199 #k2
#optimal_param = 0.4910228734917994 #k1

print(optimal_param)

df['sim_corr'] = df['sim']/optimal_param #correction factor C = 1/k

count_sim_corr = len(df[df['sim_corr'] > 0.61])
print('sim_corr > 0.61:',count_sim_corr)

count_sim = len(df[df['sim'] > 0.61])
print('sim > 0.61:',count_sim)

count_obs = len(df[df['obs'] > 0.61])
print('obs > 0.61:',count_obs)

```

In [ ]:

```

'''Different objective functions for goodness-of-fit'''

def NSE(sim, obs):
    return (1-(np.sum((sim-obs)**2)/np.sum((obs-np.mean(obs))**2)))

def peak_error(sim,obs):
    return sim.max()/obs.max()

def kge(sim, obs):
    """Calculates Kling-Gupta Efficiency (KGE) between two time series.
    Args:
        sim (np.array): Simulated time series.
        obs (np.array): Observed time series.
    Returns:
        float: KGE value.

    Optimal = 1
    """
    r = np.corrcoef(sim, obs)[0, 1]
    alpha = np.std(sim) / np.std(obs)
    beta = np.mean(sim) / np.mean(obs)
    kge_val = 1 - np.sqrt((r - 1)**2 + (alpha - 1)**2 + (beta - 1)**2)
    return kge_val

```

In [ ]:

```

""" Calculating NSE, peak error and KGE for the simulated and corrected simulated dataset

NSE_corr = NSE(df['sim_corr'], df['obs'])
peak_corr = peak_error(df['sim_corr'], df['obs'])
kge_corr = kge(df['sim_corr'], df['obs'])

NSE1 = NSE(df['sim'], df['obs'])
peak = peak_error(df['sim'], df['obs'])
kge1 = kge(df['sim'], df['obs'])

print('NSE for corrected data: ',NSE_corr)
print('NSE for simulated data: ',NSE1)

```



```
print('Peak error for corrected data: ', peak_corr)
print('Peak error for simulated data: ', peak)

print('KGE for corrected data: ', kge_corr)
print('KGE for simulated data: ', kge1)
```

In [ ]:

```
'''Plotting to check the corrected data'''

fig, ax = plt.subplots(figsize = (10,5))

sns.color_palette("rocket")

plt.plot(df['obs'], label = 'Observed: ' + str(count_obs), color = color[4])
plt.plot(df['sim_corr'], label = 'Corrected simulated: ' + str(count_sim_corr), color = color[5])
plt.plot(df['sim'], label = 'Simulated: ' + str(count_sim), color = color[9])

plt.axhline(y=0.61, color= 'red', label = 'weir height: 0.61m')

plt.title('01.01.2018 - 30.11.2022, correction factor: ' + '1/'+ str(optimal_param), fontweight='bold')
plt.ylabel('Water depth')
plt.legend()
plt.show()
```

## A6 Design precipitation for step 1 solutions (Code)

**Calculate design precipitation** The design precipitation is assumed to be the event which leaves 90% of the precipitation to the stormwater system, and 10% to excess (surface).

In [ ]:

```
import pandas as pd
import numpy as np
import matplotlib.pyplot as plt
import scipy as sp
from scipy.optimize import differential_evolution
import csv
import os
```

In [ ]:

```
#liste med navn precipfiler i CSV
folderpath= 'C:/Users/cajsarw/OneDrive - NTNU/10.semester (Master)/SWMM/02_Data/Max_min_r
filenames = os.listdir(folderpath)
```

In [ ]:

```
'''Count choses file in the filenames to use in the calculations. This was done for all 3
timeseries and the historical one. C = [1,..,30]'''

count = 0
```

In [ ]:

```
'''reading selected file and changing date to date time format and summerizing 24H'''

df = pd.read_csv(folderpath + filenames[count], sep=';', header = 0)

df['Date'] = pd.to_datetime(df['Date'], format= '%d.%m.%Y')
df = df.set_index('Date')
df.resample('24H').sum()

'''For historical'''
#df['Timestep'] = pd.to_datetime(df['Timestep'], format= '%d.%m.%Y %H:%M')
#df = df.set_index('Timestep')
#df.resample('24H').sum()
```

In [ ]:

```
#total precipitation over the 5 years
P = sum(df['Precipitation_mm'])

#P which is NOT handled by the system (assume 10% of total)
excess_precip = 0.1*P
```

In [ ]:

```
def excess_vp(threshold, P_data):
    rawExcess = P_data - threshold[0] # vector operation to be faster, has negative values
    excess_P = np.sum(rawExcess[rawExcess>0]) # sum only the positive values
    return excess_P
```

In [ ]:

```
def optimized_threshold(resolution, time_period): #resolution = string
    res = resolution
    tp = time_period
    optimized_t = differential_evolution(thresh_opt, bounds=[(0.01,10)], strategy='best1l
    return print(f'The optimized threshold (design P event) for {tp} is {round(float(opti
```

In [ ]:

```
res = 'mm/6min'
time_period = filenames[count]
optimized_threshold(res, time_period)
```

**A7 Project Thesis of Fall 2022**

**Retrofit of Urban Drainage Systems**  
**A possibility study of Lademoen, Trondheim**

by

Cajsa Ryrfors Wien

Specialization thesis

Supervisor: Tone Merete Muthanna

December 2022



**NTNU**

Department of Civil and Environmental Engineering  
Faculty of Engineering  
Norwegian University of Science and Technology

## Abstract

Reduced water quality in water bodies connected to urban drainage systems is a pressing issue. In combination with more extreme and wet weather due to climate change, the subject has gained international attention. The European Union has addressed the issue, and has as a response launched the project StopUP, which aims to improve the protection of exposed water bodies. NTNU is one of the partners in StopUP and this thesis is written as part of NTNU's contribution in the project.

This thesis is a specialization thesis which is a pre-study for the master thesis which will be written in the spring semester of 2023. The objectives of the thesis are to evaluate if there is enough space for implementation of Sustainable urban Drainage Systems (SuDSs) in the project area at Lademoen to determine if SuDS is a possible solution as Step 1 solution for stormwater management, test methods for calculation of design precipitation events, and use QGIS as a tool for area calculations.

An area in Lademoen district in Trondheim has been chosen as project area for this thesis as part of the municipal plan for water (VA-plan) as well as investment area for social development (La'mosatsinga). Possible areas for implementation of SuDSs as Step 1 solutions from the three-step strategy has been reviewed as improvement of both aesthetics and stormwater management. The SuDS chosen is rain gardens which has been designed based on existing guidelines. The total surface area has been based on precipitation data for both historical and future, modelled timeseries. By using QGIS, the available area of the project site has been found, resulting in the conclusion that there is in theory enough space available for implementation of rain gardens in the project area. The satisfying result found in this thesis suggests that implementations of rain gardens can be further evaluated as a solution for improved stormwater management in Lademoen district. In the master thesis, the effect of the SuDS on combined sewer overflows will be reviewed.

## Contents

Abstract.....	2
Figures .....	5
Tables.....	5
1. Introduction.....	6
1.1. Motivation.....	6
1.2. Background.....	6
1.2.1 Municipal plan for water in Trondheim.....	6
1.2.2 Three-step strategy for sustainable urban drainage systems .....	6
1.2.3 StopUP.....	7
1.2.1 La'mosatsinga.....	8
1.3. What is a nature-based solution? .....	9
1.4. Infiltration-based SUDS.....	10
1.5. Objectives of the specialization project .....	11
2. Relevant regulations and policies .....	12
2.1. Method for literature search.....	12
2.2. Existing standards and guidelines for stormwater management .....	12
2.2.1 VA-norm Trondheim municipality.....	12
2.2.2 VA-blad.....	13
3. Method.....	14
3.1. Selection of project area.....	14
3.2. Project area site description .....	14
3.3. Data collection .....	15
3.3.1 Precipitation data.....	15
3.3.2 Data used in GIS .....	16
3.4. Data analysis .....	16
3.4.1 Calculation of land use and available area.....	16
3.4.2 Calculation of design precipitation event.....	17
3.4.3 Calculation of area of rain garden needed.....	18
4. Results.....	20
4.1. Design precipitation event .....	20
4.2. Area calculations.....	22
4.3. Area of Rain Garden needed.....	23
5. Discussion.....	24
5.1. Uncertainties in $P_{\text{design}}$ .....	24
5.2. Private and public properties.....	24

5.3. Uncertainties in land use.....	25
5.4. Choice of formula for rain garden area.....	26
5.5. Next step .....	26
6. Conclusion .....	27
References.....	28

## Figures

Figure 1: Three-step strategy for sustainable urban drainage systems. Translated to English from (Paus, 2018).....	7
Figure 2: Investment area Lademoen, as well as districts Møllenberg and Midtbyen. Picture from (Saksfremlegg, 2021) .....	9
Figure 3: Typical design of a rain garden in Norway (Paus et al., 2015) .....	11
Figure 4: Project area with boundaries .....	14
Figure 5: Buildings of heritage in the project area (Kulturminnesøk, 2022).....	15
Figure 6: Precipitation events for the historical (1987-2020), model 0 and model 1 (2071-2099) .....	20
Figure 7: Yearly design precipitation events for the three datasets historical (1987-2020), model 0 and model 1 (2071-2099).....	22
Figure 8: Project area (marked red) and roof area (marked green) as polygons (shapefile) in QGIS. ....	22
Figure 9: Project area with unavailable area displayed in white. NOTE: the figure does not show sidewalks and unmarked parking spaces as unavailable. ....	22
Figure 10: Overview of properties owned by the municipality (brown, pink and green) and private properties.(Trondheim Kommune, n.d.) .....	25

## Tables

Table 1: Design precipitation event for entire time series .....	21
Table 2: Land use in the project area at Lademoen .....	23
Table 3: Area of rain garden surface needed for each $P_{\text{design}}$ .....	23

# 1. Introduction

## 1.1. Motivation

Due to climate change the world face challenges connected to change in weather patterns. For Trondheim this will result in wetter and more extreme weather (Klimaservicesenter, 2022). Precipitation with higher intensities results in runoff which can overreach the capacity of combined sewers and conventional separates systems for wastewater and stormwater. The change in weather pattern calls for sustainable solutions to tackle urban stormwater to protect both humans and the environment.

The public's connection to the water bodies close to their residences has become stronger than before, and people want to use their surroundings for recreation. In Trondheim an increase in interest in bathing in the Trondheim fjord has developed. This can for instance be seen through the interest in the sauna and culture center [Havet Arena](#) in Nyhavna. The change in culture of coastal cities calls for solutions for better water quality to ensure public health.

In addition to the public interest, the European Commission has proposed a new and stricter directive concerning urban wastewater treatment. This includes the reduction of Combined Sewer Overflows (CSOs) and Stormwater overflows (SWOs) (EU ENV, 2022, art. 5), which means that solutions for reducing overflows from urban water needs to be prioritized.

## 1.2. Background

### 1.2.1 Municipal plan for water in Trondheim

Trondheim municipality operate 1400 km of sewers, with 335 km being combined sewers. This does not include the private pipes (*Kommunedelplan Vann i Trondheim - 13 Avløpssystemet*, 2022). The system is designed for storm events with 20-year return period calculated from the reference period 1971 to 2000. In the future this will not be sufficient, as the 20-year storm event will occur every 2-5 year. In the municipal plan for 2022 to 2033 separation of around 60% of the pipes is recommended (Trondheim Kommune, 2022). In some parts of the city, such as the historical Midtbyen where there are old houses, narrow street and there is lack of documentation of the old sewers, separating combine sewers have been considered insufficient (VA-norm, 2022). In most parts however, separation is planned. In addition to separation of the sewer system, the municipality plans to implement solutions according to the Three-step strategy which is described in section 1.2.2.

### 1.2.2 Three-step strategy for sustainable urban drainage systems

The three-step strategy is a strategy developed to minimize the consequences of urban runoff. It aims to be a simple guideline for municipalities and other stakeholders to develop cities and urban areas with sustainable urban drainage systems. Sustainable urban drainage systems have the objective to protect human safety and health, prevent environmental pollution and prevent flooding (Tscheikner-Gratl, 2022). This thesis will focus on Step 1 solutions for the project area chosen in the Lademoen district. A visualization of the three-step strategy is shown in Figure 1.

Step 1 aims to collect, clean and infiltrate runoff from small precipitation event with the objective to ensure a sustainable water quality and protection of the local environment. Small



precipitation events are considered events with precipitation  $> 20\text{mm}$  (Lindholm, 2018). Examples of Step 1 solutions are rain gardens and green roofs. These are solutions where surface water is lead to filters instead of directly to pipes.

Step 2 aims to detain and retain runoff where Step 1 solutions are not sufficient. This includes detaining and retaining runoff from large precipitation events through for instance green roofs, rain gardens and/or basins. Large events are considered events with precipitation of 20-40mm (Lindholm, 2018).The objective is to hold back runoff to ensure that the combined or separated sewer system can handle the water load without an overflow occurring. Preventing combined sewer overflows (CSOs) or pluvial flooding of manholes is an issue of protecting public health.

Step 3 is the last out of the three steps and aims to secure safe flood paths for runoff from extreme runoff events when flood preventing measures are not sufficient. This includes construction roads which can act as flood paths and securing areas with risk of erosion. Extreme events area considered events with precipitation larger than 40mm or a precipitation event with 100-year return period (Lindholm, 2018).

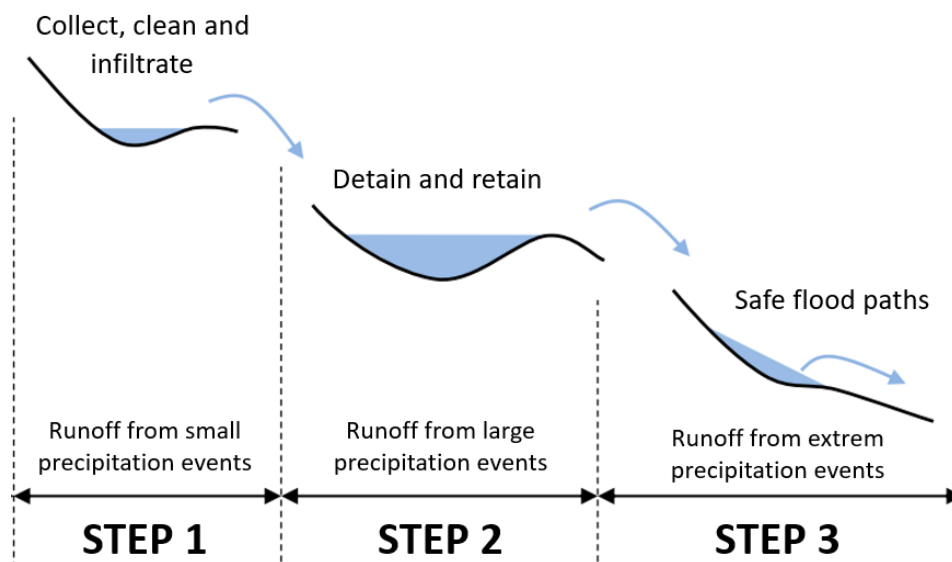

Figure 1: Three-step strategy for sustainable urban drainage systems. Translated to English from (Paus, 2018)

### 1.2.3 StopUP

Due to an increase of pollution in water bodies which are receiving urban runoff, the European Union has launched a project which aims to develop solutions to protect exposed water bodies. The object of the project is to provide technical solutions, information, tools, and guidance to limit the impact of urban pollution in water bodies. The solution from this study needs to consider local factors such as geography, climate, land use and receiving water bodies. The project is financed by the European Union and have a duration of 36 months starting September 1<sup>st</sup> 2022. (RWTH, 2022)

NTNU has been given the work package title “Urban Runoff management” which is the fourth out of eleven work packages given to universities, water utilities, consultants, and SMEs in

seven European countries and in Tunis. The objective of NTNU's work package is divided into three parts:

1. A guideline for city wide urban diffuse pollution measurement campaigns – what to measure, how to measure and where to measure with and without prior knowledge of the system.
2. Decision support tool based on the output from WP3 and WP1. Development of innovative treatment concepts; how to select the right treatment option; selection of decision criteria for treatment identification needs and water quality performance indicators.
3. Evaluation of the effectiveness of a SuDS (Sustainable Urban Drainage Systems) design using the WQ Interception tool

(StopUP, 2021)

Polluted water from Combined Sewer Overflows (CSOs) is one of the main components which must be reduced to improve the water quality of urban water bodies. Separating the urban drainage systems from sewers and implementation of SuDSs are solutions which can reduce the daily water load in CSOs.

### 1.2.1 La'mosatsinga

This section will describe La'mosatsinga based on the case presentation provided by Trondheim Municipality (*Saksfremlegg*, 2021).

In 2020 Trondheim Municipality was asked by the chairmanship to evaluate new possible investment areas, after satisfying results from the area investment "Områdeløft Saupstad-Kolstad". March 23<sup>rd</sup>, 2021, Trondheim Municipality elected Lademoen and Tempe-Sorgenfri to be the new areas of investment. The project aims for a holistically effort in equalizing social differences between different districts withing the municipality. The name of the project in Lademoen district is called La'mosatsiga. Like the project "Områdeløft Saupstad-Kolstad", will La'mosatsinga be a collaboration between the state, municipality, county government and the local community.

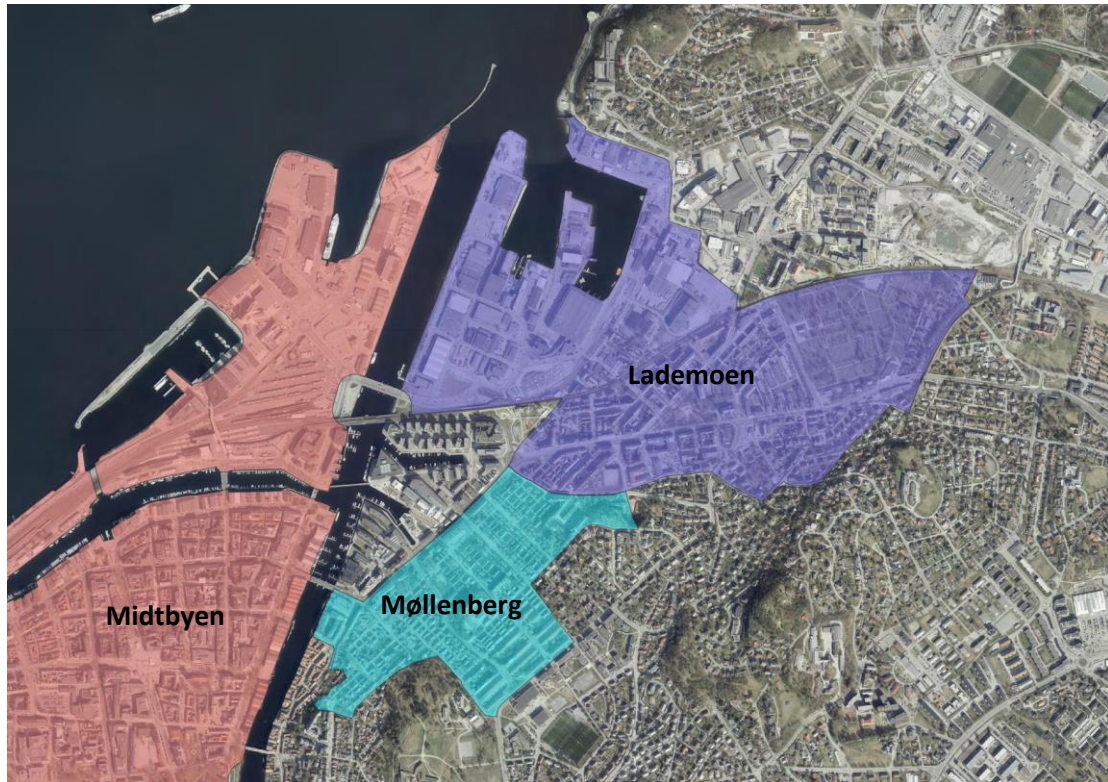

Figure 2: Investment area Lademoen, as well as districts Møllenberg and Midtbyen. Picture from (Saksfremlegg, 2021)

Lademoen district was elected as investment area based on the challenges in living conditions which have been documented. The investigation on living standard included social, economic and health condition of the residents.

The case presentation states four issues to consider.

- How can networks and initiatives which unite different groups of citizens be further develop?
- How can public services and properties be developed as arenas and tools to create good local communities and vibrant local environments, and contribute to strong communities for children?
- Can good cultural heritage protection increase the social mix and attractive living spaces, and at the same time contribute to an age-friendly urban environment which includes students, immigrants, children, and elderly?
- How can the development of private and public housing and urban spaces contribute to more attractive living spaces and better living environment?

This thesis aims to contribute to the second and third point of the issues to consider, by implementing nature-based solutions which will safely transport stormwater as well as possibly increase green space.

### 1.3. What is a nature-based solution?

Nature based solutions (NBS) are technologies which are inspired by nature and objects to replicate or use natural processes for managing water (Frantzeskaki, 2019). Specifically, NBSs have been defined as living solutions which supported by nature aim to be cost-effective, give

social and economic benefits, while simultaneously provide environmental benefits and help build resilience. It aims to support natural diversity, natural features and processes into urbanized areas, landscapes and seascapes, through local adaptation and efficient use of resources (European Commission, n.d.). In this case, NBS has the purpose of managing stormwater as part of the urban drainage system.

Many different names have been developed under the definition above. The name of the solution differs geographically, however is based on the same definition and have the same purpose. For instance, is the term SuDS (Sustainable urban drainage systems) used in the United Kingdom, LIDs (Low Impact Developments) used in the USA, WSUDS (Water Sensitive Urban Design) used in the Middle East and Australia (Wikipedia, 2022), and LOD (Lokal Overvannshåndtering) is used in Norway (Lindholm, 2018). In this thesis the term SuDS will be used.

#### 1.4. Infiltration-based SuDSs

One of the most popular types of SuDS are infiltration-based solutions. These are solutions containing filters. The filters includes a bed of specified porous filter media, storage volume to temporarily hold runoff while processing the incoming water, an underdrain system for filtered water, and a bypass or spillway which is activated when the volume capacity of the filter is reached (WEF & EWRI (U.S.), 2012). An infiltration solution can have multiple objectives; improve water quality, temporary storage of stormwater to control peak flows (WEF & EWRI (U.S.), 2012), redirect of water through the underdrain system and infiltrate stormwater to the groundwater table to reduce stormwater volumes. This means that infiltration-based solutions can be both Step 1 and Step 2 solutions in the three-step strategy.

The function of the filter is dependent on the design of the solution and local factors. For treatment, the total surface area of individual grains in the filter media and the contact time of the water is important to obtain better water quality. For stormwater peak reduction, the storage volume is the main driver. (WEF & EWRI (U.S.), 2012) Examples of infiltration-based solutions are infiltration trenches, swales and bioretention systems such as rain gardens. Swales and rain gardens are examples of vegetated surfaces. (Butler et al., 2018, p. 454)

Rain gardens intercept runoff from storm events with high return period and treat the stormwater, usually through sandy filter media. The treatment of the water is mechanical filtration combined with sedimentation, adsorption and uptake from plants and microbial activity in the filter media. (Hatt et al., 2009) A typical rain garden design can be seen in Figure 3 (Paus et al., 2015). If the rain garden is suitable for infiltration to the groundwater table is dependent on the properties of the local soil. In the case of Lademoen, the local soil is unclassified (NGU, n.d.) and infiltration tests would have to be conducted to determine if rain gardens can be used as a volume reducing measure. In this thesis rain gardens are selected as a measure for water quality improvement. The impact of the rain garden on CSOs cannot be known without running a model. This will be done in the master thesis which will be written spring semester of 2023.

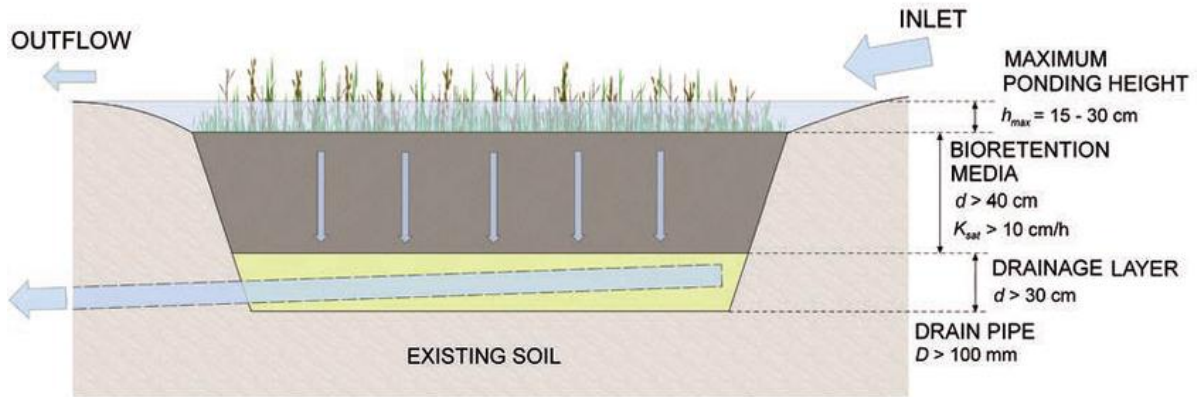

Figure 3: Typical design of a rain garden in Norway (Paus et al., 2015)

### 1.5. Objectives of the specialization project

The objective of this thesis is to calculate the available area for implementation of nature-based solution collecting water from the roofs in the project area in Lademoen district. The thesis will explore methods for analysis of precipitation data and GIS methods which will be used in the master thesis which will be written spring semester of 2023.

More specifically:

1. Is there enough available space in the project area to implement rain gardens designed as a Step 1 solution for runoff from roofs?
2. Testing a method for calculation of design precipitation events using historical and future modelled time series
3. Use QGIS as a tool to analyze available area for nature-based solutions in the project area

## 2. Relevant regulations and policies

### 2.1. Method for literature search

The very first source of information in this thesis was the project description document for the EU project StopUP which was provided by Tone Muthanna. From the StopUP project description keywords which have been used to search for relevant information was selected. Especially the keywords “SuDS”, “Nature-based solutions” and “LIDs” have been used to collect relevant articles from the websites [Scopus](#), [ResearchGate](#) and [Google Scholar](#). After searching for relevant information using keywords the “Snowballing” technique (i.e., following the sources used in articles) was used to find further sources of information. In addition, has the list of articles of which the current source has been cited in been reviewed to find related articles.

This thesis is strongly connected to municipal work, which means that governmental standards, rules, and guidelines must be considered. This information has been found through the platforms [va-blad.no](#) and [va-norm.no](#). Further information about the municipality’s plan for the project has been found on the [website of Trondheim Municipality](#) and on the [Facebook site of La’mosatsinga](#). The names of the authors from the municipal documents and VA-sheets have been searched for on the websites stated above to find articles written by the same author.

Further has learning material from courses at NTNU, Department of Civil and Environmental Engineering been reviewed to find background for statements in the thesis. Specific lecture notes from the courses TVM4125, TVM4130 and TVM4141 have been used.

In the literature study the quality and relevance of the sources has been ensured by using sources from reliable sources such as recognized websites for scientific publications, and government issued documents. The relevance was ensured by looking at the publication date of the source, and through reading making sure that the information is still pertinent. Sources in multiple languages (Norwegian, English, and Swedish) have been reviewed.

### 2.2. Existing standards and guidelines for stormwater management

#### 2.2.1 VA-norm Trondheim municipality

Each municipality in Norway has a set of standardized rules for how the water systems, sewer systems and urban drainage systems should be constructed. These are found in the municipal guideline called VA-norm (Vannforsynings og avløps norm). The VA-norm is open for private use and can be found at the website of the municipality or at [va-norm.no](#) which is provided by [Norsk Vann](#).

The guidelines and rules for stormwater systems in Trondheim Municipality is described in section 7 *Transportation system – Stormwater* of Trondheim Municipality’s VA-norm. It is made clear already in section 7.0 that the municipality wishes runoff to be handled locally, and references to possible solutions are included. The VA-norm also states standards for calculation of stormwater runoff, type and size of pipes, and minimum slope for self-cleanse. There is also information about connecting pipes to the drainage system, standards for manholes and gully pots, as well as requirements for maintenance and replacements.

The VA-norm includes very little information about solutions for local stormwater. It does however refer for [VA-blad no. 92 surface water infiltration](#) and [VA-blad no.93 open flood paths](#). These have not been used in this thesis as they are more relevant for Step 2 and 3 solutions.

### 2.2.2 VA-blad

There exists multiple VA-blad (water supply and sewer sheets) for stormwater management. VA-sheets are documents provided by the foundation VA/Miljø-blad. The sheet which is the most relevant to this thesis is VA-blad [no. 125 Managing stormwater – LID](#) . The sheet includes background information about local management of stormwater, introduction to the three-step strategy as well as technical solutions for each step. It is a guideline for municipalities and water management consultants for better local stormwater management. Other VA-sheets relevant in the topic of stormwater management can be found by searching for the keyword “overvann” on the website [va-blad.no](#).

### 3. Method

#### 3.1. Selection of project area

The project area for this thesis was selected by looking at available boundaries. In this case the boundaries chosen was the railway in the North, Innherredsveien in the South, and Thomas von Westens gate in the East. The western boundary was set to Strandveien and the main pedestrian road from Innherredsveien to Strandveien. The project area can be displayed in Figure 4.



Figure 4: Project area with boundaries

#### 3.2. Project area site description

After the selection of the project area, an excursion was conducted to do observation October 1<sup>st</sup>, 2022. This section will describe the observations made, as well as other relevant information.

The project area is an urban part of Trondheim city mostly consisting of apartment buildings. In the western part there is a neighborhood of smaller wooden houses, while the rest of the district consists of larger concrete apartment buildings. The roofs of the houses are mostly angled, with roof drains connected to underground pipes. The area is mostly residential, however does also include some local businesses such as hairdressers, cafes and fast food, kindergartens and Lademoen Kunstverksteder.

The streets are wide, however consist mostly of roads, sidewalks, and parking spaces with sealed surfaces. Lademoen Kirkeallé is newly renovated, and the combined sewers have been replaced with a separate system for urban drainage. Thomas von Westens gate is under construction for the same purpose. In Lademoen Kirkeallé the water from the roof drainage of the closest buildings is directed into a NBS where the new trees are watered. In this thesis this is not considered in the calculations, however it will be included in the master thesis following this thesis.

The railway runs along the northern border of the project area, and there are 5 crossings of which 3 are pedestrian crossings and 2 are designed for vehicles. All crossings run under the railway. The largest crossing is the one in Nidarholms gate, which is a quite trafficked road which also includes the bus stops Buran and Anders Buens gate.



Along many of the roads there are trees of various types and ages. In Lademoen Kirkeallé new trees were planted shortly before the visit. The project area includes Lademoen park, which is a recreational area next to Lademoen Church. Very few of the buildings have gardens, however, some of the courtyards include parts with lawns and trees. Except for Lademoen Park is Trondheim Voldsminne, the eastern part of the project area, the part with the largest areas of green space between the buildings. Trondheim Voldsminne, also include a large lawn with trees planted on both sides.

Many of the houses are considered heritage and are built in the end of the 19<sup>th</sup> century. The wooden houses in the West are protected by the Plan and Building Act, while others are considered heritage without any specific protection. Figure 5 displays all buildings in the project area which are considered heritage interest either on national or local scale. (Kulturminnesøk, 2022)



Figure 5: Buildings of heritage interest in the project area (Kulturminnesøk, 2022)

### 3.3. Data collection

#### 3.3.1 Precipitation data

The precipitation data used in this thesis was provided by PhD candidate Vincent Pons at Department of Civil and Environmental Engineering at NTNU. The data are time series of precipitation for Trondheim which are downscaled to an hourly resolution using the MRC-SIT-SEP model. The precipitation is given in unit millimeters per hour. The files include temperature values for each time step; however, this information has not been used. The future data has been produced using global climate models (GCM) dynamically downscaled with regional climate models (RCM, of EURO-CODEX data) and statistically downscaled to 1 x 1 km grid with bias correction. Three datafiles were given:

1. *1987\_2020\_hour\_res\_Prec\_Temp.txt* includes precipitation and temperature values in hourly resolution for the period 1987 to 2020. The data is based on measured values which are downscaled to hourly resolution.

2. *2071\_2099\_hour\_res\_Prec\_Temp\_model0.txt* includes precipitation and temperature values in hourly resolution for the period 2071 to 2099. The dataset is made using CNRM-CERFACS-CM5 GCM combined with the CCLM4-8-17 RCM. This model will hereafter be called model 0.
3. *2071\_2099\_hour\_res\_Prec\_Temp\_model1.txt* includes precipitation and temperature values in hourly resolution for the period 2071 to 2099. The dataset is made using CNRM-CERFACS-CM5 GCM combined with the RCA4 RCM. This model will hereafter be called model 1.

The method for downscaling of the data is further described in the NVE report [Gridded 1x1 km climate and hydrological projects for Norway](#) (Kwok Wong et al., 2016). In this thesis only two climate models for precipitation will be used to show the methodology for the master thesis which will be written spring 2023. In the master thesis 10 different climate models and possibly multiple RCP scenarios will be used to model the future precipitation.

The plotted data can be seen in Figure 6.

### 3.3.2 Data used in GIS

QGIS (QGIS 3.22, 2022) has been used to analyze the land use in the project area. Aerial photos was needed as a base map in QGIS. Aerial photos with a resolution of 0.1 x 0.1m has been downloaded from [Norge i Bilder](#) with the help from Professor Knut Alfredsen.

Because the aerial photos are 2 years old, Google Maps in 2D and 3D with pictures from 2022 has been used to validate the information from the aerial photos. [Google Maps](#) has also been used to clarify if there were any constructions which was covered by vegetation, and therefore not visible on the aerial photos. OpenStreetMap from XYZ Tiles in QGIS had been used to verify the roads, buildings, and parking lots. OpenStreetMap is an open-source map provided by [OpenStreetMap](#) in QGIS and includes information about roads and constructions.

The coordinate system used for all GIS-data was EPSG:25833 - ETRS89/ UTM zone 33N.

## 3.4. Data analysis

### 3.4.1 Calculation of land use and available area

The total percentage of the project area was calculated using QGIS. Aerial photos of the project area were used as a base map. A shapefile containing one polygon for the selected project area was created. Thereafter, a shapefile containing polygons of projected roof areas, which were manually selected, was made.

The area of each polygon in the layers for project area and roofs were calculated using the \$area operator in QGIS. The data was then transferred to Excel where the total roof area was calculated by summing the areas of each roof polygon. The percentage of the total area which is covered by roofs was calculated.

To find the area which is available for stormwater handling solutions (retrofit), the area from all roads and sidewalks, marked parking spaces and a part of Lademoen Park was extracted.

To simplify, and to minimize the manual work in QGIS, it was assumed that there is 2 m of sidewalk on each side of the road for all roads. The length of the roads was found by creating a shapefile with LineStrings in the center of each road. The marked parking spaces refers to parking lots which are included in OpenStreetMap. OpenStreetMap does not include parking slots on the sides of the roads. A part of Lademoen Park was excluded from the available area because of the distance from nearby roof areas. It is therefore not reasonable to install SuDSs connected to roofs in this area.

The calculation of available area was done by finding the area of each polygon in the layers for project area, unavailable park area, roads, and parking. The data was transferred to Excel where the total area for each layer was calculated. The sidewalk calculation was done in Excel by adding 4 m<sup>2</sup> to the total area of the roads for each meter road length. The available area was calculated by subtracting the sum of the unavailable areas (park, roads and sidewalks, and marked parking) from the total area.

### 3.4.2 Calculation of design precipitation event

The precipitation data was firstly plotted to look for errors (Figure 6). Some minor gaps in the precipitation events from 1987- 2020 was noticed. These gaps were not filled assuming that these events occurred during the winter and that the precipitation fell as snow. Since snow does not create immediate runoff, the values were kept as 0.

To calculate the design precipitation event ( $P_{\text{design}}$ ) it was assumed that the precipitation is evenly distributed in the entire project area. The goal of the SuDS which will use  $P_{\text{design}}$  as input data, is to capture enough stormwater to avoid daily CSO events. The impact of the SuDSs cannot be known without modelling, however, a rule of thumb where the existing system for urban drainage can handle 90% of the total volume in a time series, while 10% should have a separate solution is used.

The calculation of the 10% excess precipitation design event threshold was done using Python. The threshold event is an event where the total volume handled by the system is equal to 90% of the total precipitation volume, while 10% of the total volume is excess water which will go to the surface. The optimizer differential\_evolution from Scipy was used to minimize the difference between the calculated 10% of the total precipitation volume in the time period, and the total volume of the excess precipitation assuming the system can handle the volume from precipitation events with an intensity lower than the threshold event.

First the design precipitation event was calculated using the entire time series for each of the three data files provided. This resulted in three results. Next, the same calculation was done for each year in the three time series to show the natural yearly variability (

Figure 7).

The data used is in the unit millimeters per hour. The design precipitation event has the same resolution, hourly, because the event will be used in calculations for rain gardens designed as a Step 1 solution in the three-step strategy. The goal is to catch the first flush.

The code is provided in the Appendix I.

### 3.4.3 Calculation of area of rain garden needed

The design of a rain garden needed to handle the design precipitation event is determined by local climate and access to space (Paus & Braskerud, 2013). This thesis will not design one or more specific rain gardens, however, look at the surface area is needed to manage  $P_{\text{design}}$  on roofs for the entire project area.

The total area needed for rain gardens was calculated using Equation 1, which is derived from the formula provided by WEF & EWRI (U.S.), (2012, p. 296).

*Equation 1: Area of a rain garden*

$$A = \frac{A_{\text{drain}} * C * P * d_f}{K_{\text{sat}} * t_f * (h_f + d_f)}$$

where

$A$  = surface area of the rain garden [ $\text{m}^2$ ]

$A_{\text{drain}}$  = drainage area [ $\text{m}^2$ ]

$C$  = average runoff coefficient of the drainage area [-]

$P$  = design precipitation event [cm/hr]

$d_f$  = depth of the media filter [cm]

$t_f$  = drainage time

$K_{\text{sat}}$  = saturated hydraulic conductivity [cm/hr]

$h_f$  = average height of water above filter media, usually  $h_f = \frac{1}{2} * h_{\text{max}}$

where  $h_{\text{max}}$  is the maximum height above the filter media possible before overflow.

In this case the drainage area is the roof area in the project area, and  $P$  is the design precipitation event calculated as described in 3.4.2 converted to cm/hr. The average runoff coefficient is set to 0.9 because of the assumption that the roofs act close to impermeable (SWRCB, 2011). The drainage time is set to 1hr, which is the same as intensity, because the distance from the roofs to the rain garden is considered too small to give any temporal delay (Paus & Braskerud, 2013).  $K_{\text{sat}}$  is set to 10 cm/hr, to be sufficiently high for the variable climate (Paus et al., 2015).

In Paus and Braskerund's paper *Forslag til dimensjonering og utforming av regnbed for norske forhold* another formula for calculation of the area is presented. This formula does not take the depth of the filter media into account and can therefore be used to design deeper rain gardens than recommend. For geotechnical reasons, it is not recommended to have excavations close to buildings, and the formula from WEF & EWRI is therefore preferred in this case.

In this thesis the pilot project at Risvollan has been used as a guide for parameters used for rain gardens at Lademoen.  $d_f$  is set to 75cm, and  $h_{\text{max}}$  is 16 cm. (Paus & Braskerud, 2013). The calculations were done using Python for  $P_{\text{design}}$  for the three different time series provided

(historical, future model 0 and future model 1). The Python code is provided in the Appendix II.

It should be noted that the rain garden surface area in this thesis is designed as Step 1 solution for improved water quality. It aims to catch the first flush and is therefore designed based on peak rain fall in hourly resolution rather than daily resolution which is more common. This means that the calculation in this thesis is not directly comparable to rain gardens designed using 24-hour resolution precipitation data.

## 4. Results

### 4.1. Design precipitation event

The plots of three datasets of precipitation events can be seen in Figure 6. Note that the scale on the y-axis is different for the three plots. There are some gaps in the precipitation data from 1987 to 2020. The gaps are marked in red.

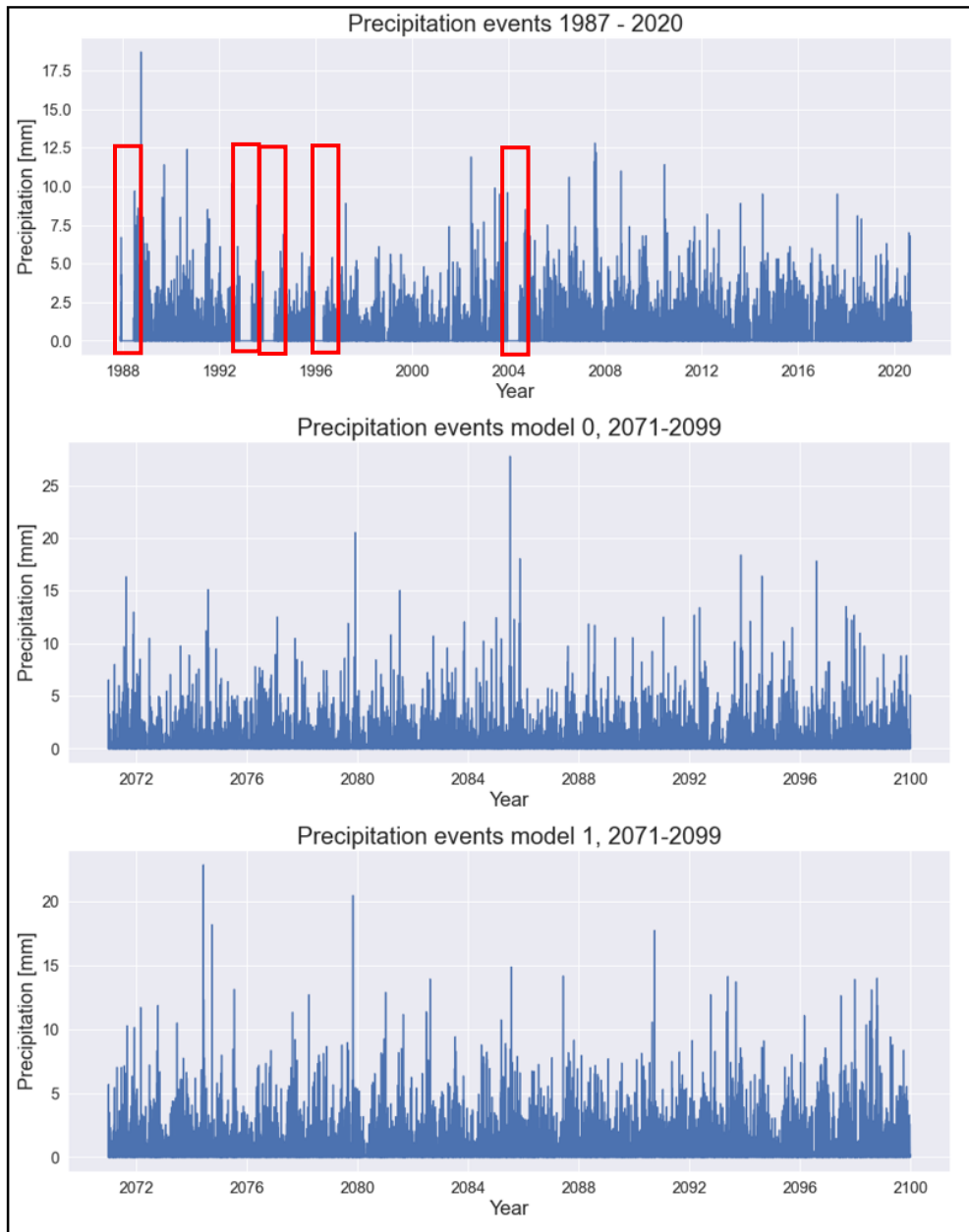

Figure 6: Precipitation events for the historical (1987-2020), model 0 and model 1 (2071-2099)

The three datasets provided gave different results for design precipitation events. The design precipitation event for the measured period 1987 to 2020 gave a result of 1.9 mm/hr while the modelled future data gave higher precipitation events; 2.4 mm/hr for model 0 and 2.5 mm/hr for model 1. The result from the design event calculations can be seen in Table 1.

Table 1: Design precipitation event for entire time series

Name	Time period	Data	$P_{\text{design}}$ [mm/hr]
$P_{d,\text{historical}}$	1987-2020	Historical, measured	1.9
$P_{d,m0}$	2071-2099	Future, model 0	2.4
$P_{d,m1}$	2071-2099	Future, model 1	2.5

The yearly design precipitation events for the three datasets show that the  $P_{\text{design}}$  for the entire time periods in some cases are underestimations and in some cases are overestimations. The variation can be seen in

Figure 7. The  $P_{\text{design}}$  for the entire dataset is visualized with a red line.

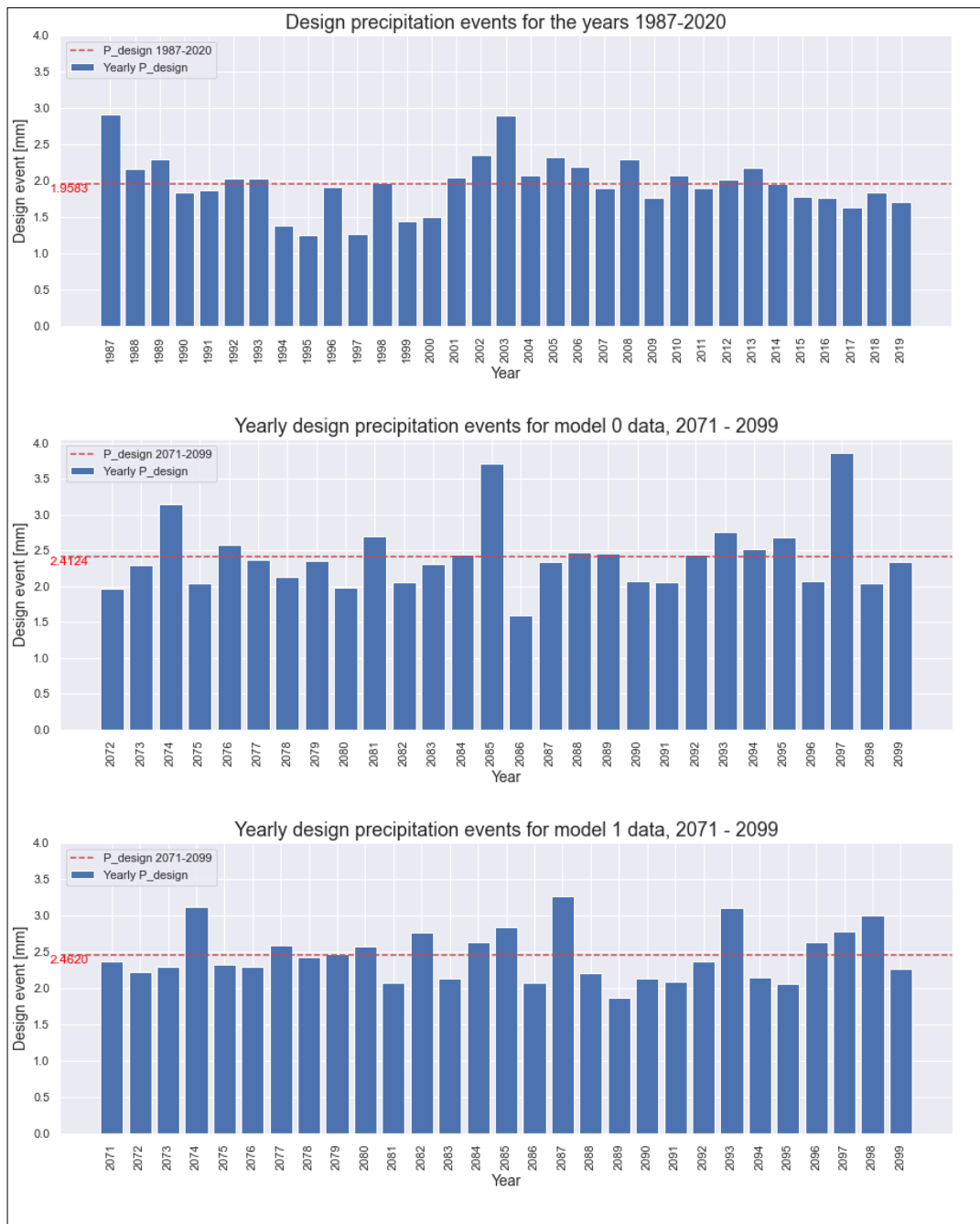

Figure 7: Yearly design precipitation events for the three datasets historical (1987-2020), model 0 and model 1 (2071-2099).

## 4.2. Area calculations

By using QGIS it was found that the total area of the project site was 189978 m<sup>2</sup>. 27.5% (52192 m<sup>2</sup>) of the area is covered by roof projections or other elevated imperious surfaces. The QGIS layers aerial photo, project area and roofs can be seen in Figure 8.



Figure 8: Project area (marked red) and roof area (marked green) as polygons (shapefile) in QGIS.

The second largest land use portion of the project area is roads and sidewalk. Roads and sidewalk occupy 26.3% of the land. Parking spots marked in OpenStreetMap, as well as the unavailable space in Lademoen Park cover a total of 8.6% of the project area surface. This means that 62.4% of the area in theory is unavailable for retrofit. In Figure 9 the project area is shown with the unavailable area marked white. The available area for retrofit, using the assumptions described, is 71525 m<sup>2</sup>. The distribution of all the land use types considered can be found in Table 2.



Figure 9: Project area with unavailable area displayed in white. NOTE: the figure does not show sidewalks and unmarked parking spaces as unavailable.



Table 2: Land use in the project area at Lademoen

Land use type	Area [m <sup>2</sup> ]	% of total area
Total area of project site	189978	-
Roofs (projected area)	52192	27.5%
Roads and sidewalks	49880	26.3%
Unavailable area in Lademoen Park	11347	6.0%
Marked parking	5033	2.6%
Total unavailable area	118453	62.4%
Total available area for retrofit	71525	37.6%

### 4.3. Area of Rain Garden needed

If the project area at Lademoen would be retrofitted to manage the stormwater for  $P_{d,historical}$  on roofs 831 m<sup>2</sup> rain garden would be needed. This equals to 4.74% of the available area for retrofit. For  $P_{d,m0}$ , 1024 m<sup>2</sup> (5.84% of the available area) would be needed, and for  $P_{d,m1}$  1045 m<sup>2</sup> (5.96%) would have to be retrofitted. The rain garden surface area needed to handle the water from a roof area of 52192 m<sup>2</sup> for each precipitation event using Equation 1 can be found in Table 3.

Table 3: Area of rain garden surface needed for each  $P_{design}$

Data	Name	$P_{design}$ [mm/hr]	Roof area ( $A_{drain}$ ) [m <sup>2</sup> ]	Area of Rain Garden surface	% of the available area
Historical, measured 1987 - 2020	$P_{d,historical}$	1.9	52192	831	4.74%
Future, model 0, 2071 - 2099	$P_{d,m0}$	2.4	52192	1024	5.84%
Future, model 1, 2071 - 2099	$P_{d,m1}$	2.5	52192	1045	5.96%

## 5. Discussion

There have been many assumptions and simplifications made when looking at available area for retrofit in the project area at Lademoen. In this section, the results will be evaluated, and the assumptions made discussed.

### 5.1. Uncertainties in $P_{\text{design}}$

When calculating the design precipitation event, the rule of thumb that the urban drainage system existing can handle 90% of the volume was used. This is a general assumption, and other percentages of urban drainage systems capacity would lead to other results. Higher capacity of the drainage system would require less area of rain gardens needed, and opposite for less capacity. The threshold value has to be derived using an urban drainage model and is strongly system dependent.

*The design precipitation event used to calculate the rain garden area needed, was the  $P_{\text{design}}$  values based on the entire time series in each of the datasets (historical, model 0, and model 1). This value is in some cases an underestimation and in some cases an overestimation. This can be seen in*

Figure 7. The peaks higher than the  $P_{\text{design}}$  for the whole time periods should be considered when designing the urban drainage systems. The risks and cost connected to the highest peak events should be assessed to evaluate which  $P_{\text{design}}$  gives a sufficient result. The lower yearly design precipitation events should likewise be evaluated when looking at cost efficiency.

$P_{\text{design}}$  is only precipitation events where precipitation gauges are operative. This means that periods of cold weather where the gauge is frozen or there is snow fall, the measured precipitation is 0. The gaps can be seen in the plot for 1987-2020 in Figure 6. These 0-values could have been replaced with values using regression or could have been excluded from the data set. These methods were excluded because the 0-value gives information about seasonal variations, were possible runoff freezes and is stored. This storage creates a delay which is affecting the rain garden surface area needed. If the dataset had been corrected for the 0-values,  $P_{\text{design}}$  for 1987 to 2020 would have been different.

### 5.2. Private and public properties

The available area was calculated without differentiating between public or private property, or if the property is classified as heritage. The parts of the available area which is on public ground can be evaluated for retrofit internally in the municipality. For the parts of the available area, which is on private property, the property owners have to be involved. The type of private property owners varies from individual households to housing associations. Housing associations may be easier to collaborate with because they own larger pieces of land and are organized with a board which can be involved instead of single households having their own representative. An overview of public and private properties in the project area can be seen in Figure 10.

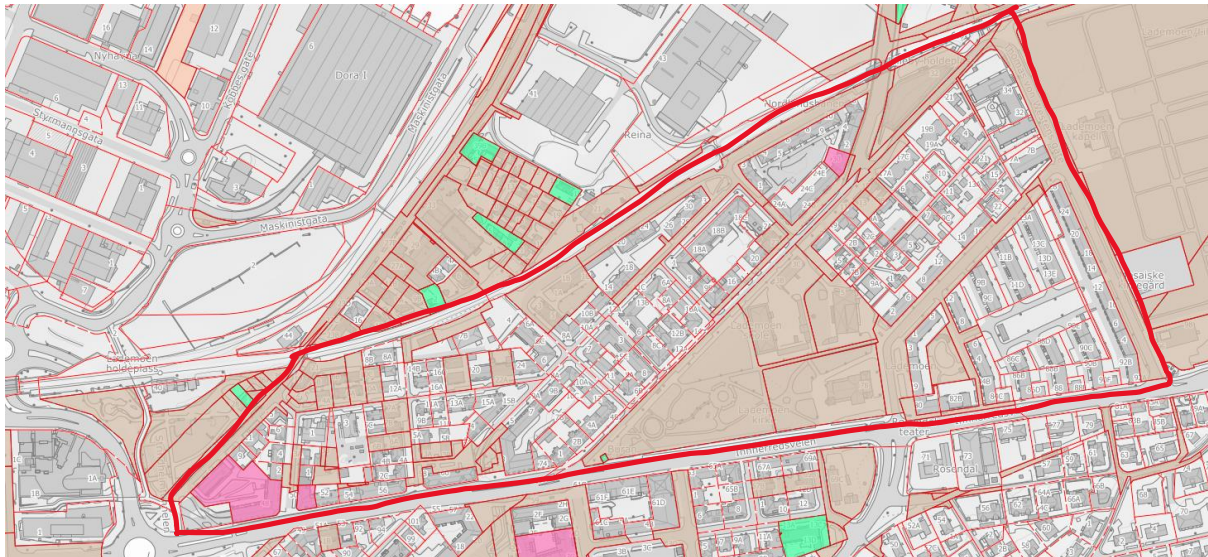

Figure 10: Overview of properties owned by the municipality (brown, pink and green) and private properties (gray). (Trondheim Kommune, n.d.)

### 5.3. Uncertainties in land use

When calculating available area, it is assumed that each meter of road has 4m<sup>2</sup> of sidewalk. This is however not the case in reality. Some roads have no sidewalk, some have sidewalk on only one side, and some have more than 2 meters on each side. The assumption does not take into account road types, which means that also pedestrian roads will get the additional area. The actual area of sidewalks could have been derived using GIS in the equivalent way as roads, however due to lack of a time efficient method for this, the area of sidewalks was assumed to be 4m<sup>2</sup> per road meter. A more thorough calculation of the sidewalk area would give a different, and more accurate result of available area.

Parking spots on the sides of the roads and in courtyards have not been included in the calculation of unavailable area. The reason for this is lack of a time efficient method for identifying spaces for parking. The parking spots which have been included are the ones which are marked in OpenStreetMap, which means that only a small part of the parking spaces have been classified as unavailable. One can discuss if the parking spots are available for implementations of SuDSs or not. In some cases, the parking spaces might be disposable for the benefit of SuDSs. It is however unrealistic to assume that all the parking spots are available like it has been assumed in this area calculation.

The area calculations do not consider the position of the available area in relationship to runoff generating roofs. The highest density of roofs seems to be found in the areas (West) with the least space available for retrofit. The few houses close to the church and the apartment buildings in Trondheim Voldsminne do on the other hand have large areas of green areas which are in theory available for implementation of SuDSs. This can be seen in Figure 9. The figure can be misleading because the parking spaces at Trondheim Voldsminne were marked in OpenStreetMap and are therefore marked unavailable, whereas the parking spaces in most of the streets in the West is not shown as unavailable. This means that the available area which is in reasonable distance from a certain roof area might not be sufficient.

Other types of land uses could have been marked as unavailable. This could for instance be spaces for garbage disposal, existing trees and gardens, post boxes or space needed to enter and

exit buildings. Space needed for storage of snow from the roads is not considered in the area calculations. Adding these spaces as unavailable area would have decreased the area available for retrofit.

#### 5.4. Choice of formula for rain garden area

The formula which was used for calculation the surface area of rain garden needed takes into account the depth of the filter media (Paus et al., 2015). In this thesis it is assumed that the filter media depth is uniform (section 3.4.3) in the entire project area. Varying the depth of the filter media leads to different calculated surface areas of the rain gardens. This means that areas where there is limited space could increase the depth of the filter media to allow for a smaller surface area. The depth of the filter media would then have to be decided based on the effectiveness of the rain garden with the decided depth.

Using the formula from WEF & EWRI (U.S.) (2012), gives a needed area which is larger than the needed area calculated by using the formula from Paus & Braskerud (2013). This is because Paus & Braskerud does not take the depth into account. This allows for rain gardens which are deeper than what is sufficient for stormwater management, constructional and economical reasons. It might, however, be a better way of calculating necessary area in areas with limited space presented.

It should be noted that the difference in rain garden surface area for the two future design precipitation events is very small (21 m<sup>2</sup>). The difference of area between the historical event and the future events is on the other hand significant. This means that an adaptation of the urban drainage system in the area has to be prioritized.

#### 5.5. Next step

The area calculations and the area needed for retrofit show that there in theory is enough space to implement sufficient area of rain garden. This means that the concept can be manageable. The next step would therefor be to review the available area and exclude areas which is not within reasonable distance from the roofs generating runoff. A more detailed area calculation would also be needed. It is important to model if the available area for rain gardens correlate with the areas where water accumulate during precipitation events. This can be done using urban drainage models.

## 6. Conclusion

The project area has an area of 1889978 m<sup>2</sup> of which 27.5% is covered by roofs. 62.4% of the area is unavailable due to other uses and includes the roof area. This leaves 37.6% of the total area in theory available for implementation of Step 1 solutions for management of runoff from the roofs.

Based on the rule of thumb that the existing urban drainage system can handle 90% of the runoff generated from the roofs the design precipitation events was calculated. The results are  $P_{d,historical} = 1.9$  mm/hr,  $P_{d,m0} = 2.4$  mm/hr and  $P_{d,m1} = 2.5$  mm/hr when the whole data series were used. The  $P_{design}$  calculated for the whole time series does not consider the natural variation of precipitation events. When designing stormwater management solutions based on design precipitation events the natural variations have to be considered to lower risks of overreaching the capacity of the urban drainage systems.

Using the design precipitation events which were calculated for each data set, it is concluded that between 5% and 6% of the area which in theory is available would have to be converted into rain garden surface to manage runoff from  $P_{design}$ . In other words, there is in theory enough available area in the project area to implement rain gardens as Step 1 solutions for stormwater management. The area needed for the rain garden might not exist in an appropriate distance to the roof from which the runoff is generated. If an area is actually available depends on the owner of the property the rain garden is thought to be placed on, and if the space is technically suitable for retrofit.

QGIS is a valuable tool to get overview of the land use in the project area. When buildings, roads and other area types of area not predefined in the maps, it is a time consuming to manually define polygons for each area. Therefore, some simplifications were made, for instance with the calculation of sidewalks. QGIS is a useful tool for visualizing maps and land use distribution and have many possibilities when it comes to presenting GIS data.

## References

- Butler, D., Digman, C., Makropoulos, C., & Davies, J. W. (2018). *Urban drainage*. CRC Press, Taylor & Francis.
- EU ENV. (2022). *Proposal for a Directive concerning urban wastewater treatment (recast)*, Directorate-General for Environment.
- European Commission. (n.d.). *European Commission: Nature-based solutions*. Retrieved December 5, 2022, from [https://research-and-innovation.ec.europa.eu/research-area/environment/nature-based-solutions\\_en](https://research-and-innovation.ec.europa.eu/research-area/environment/nature-based-solutions_en)
- Frantzeskaki, N. (2019). Seven lessons for planning nature-based solutions in cities. *Environmental Science & Policy*, 93, 101–111. <https://doi.org/10.1016/j.envsci.2018.12.033>
- Hatt, B. E., Fletcher, T. D., & Deletic, A. (2009). Hydrologic and pollutant removal performance of stormwater biofiltration systems at the field scale. *Journal of Hydrology*, 365(3), 310–321. <https://doi.org/10.1016/j.jhydrol.2008.12.001>
- Klimaservicesenter. (2022). *Klimaprofil Sør-Trøndelag*. <https://klimaservicesenter.no/kss/klimaprofiler/sor-trondelag>
- Kommunedelplan Vann i Trondheim—13 Avløpssystemet*. (2022). <https://sites.google.com/trondheim.kommune.no/kdp-vann-i-trondheim/vedleggsrapport/13-avl%C3%B8pssystemet>
- Kulturminnesøk. (2022). *Kart—Kulturminnesøk*. <https://www.kulturminnesok.no/kart/>
- Kwok Wong, W., Haddeland, I., Lawrence, D., & Beldring, S. (2016). *Gridded 1 x1 km climate and hydrological projects for Norway*. Norwegian Water Resources and Energy Directorate.
- Lindholm, O. (2018). *VA-Blad 125: Håndtering av overvann – LOD*. <https://www.va-blad.no/handtering-av-overvann-lod/>
- NGU. (n.d.). *Løsmasser, infiltrasjonspotensiale*. Retrieved December 14, 2022, from <https://geo.ngu.no/kart/minkommune/>
- Paus, K. H. (2018). *Tre-trinns strategien og dimensjonering i praksis*.
- Paus, K. H., & Braskerud, B. C. (2013). *Forslag til dimensjonering og utforming av regnbed for norske forhold*. 14.
- Paus, K. H., Muthanna, T. M., & Braskerud, B. C. (2015). The hydrological performance of bioretention cells in regions with cold climates: Seasonal variation and implications for design. *Hydrology Research*, 47(2), 291–304. <https://doi.org/10.2166/nh.2015.084>
- QGIS 3.22. (2022, March 12). *Documentation for QGIS 3.22—QGIS Documentation documentation*. <https://docs.qgis.org/3.22/en/docs/index.html>
- RWTH. (2022). *StopUP*. <https://www.fb3.rwth-aachen.de/cms/bauingenieurwesen/Forschung/Projekte/~wexll/Stop-urban-pollution-StopUP-Protecti/?lidx=1>
- Saksfremlegg*. (2021, October 3). Trondheim kommune. <https://www.trondheim.kommune.no/aktuelt/om-kommunen/annet/prosjekter-fra-a-a/omradesatsinger-i-trondheim/lademoen/>
- StopUP. (2021). *Protecting the aquatic environment from urban runoff pollution “StopUP.”*
- SWRCB. (2011). *Runoff Coefficient (C) Fact Sheet*. Waterboards Canada.
- Trondheim Kommune. (n.d.). *Trondheim, Advanced maps*. Retrieved December 15, 2022, from <https://kart5.nois.no/trondheim/Content/Main.aspx?layout=trondheim&time=638067142143284848&vwr=asv>
- Trondheim Kommune. (2022, October 20). *Kommunedelplan Vann i Trondheim—Tilpasse til et klima i endring*. <https://sites.google.com/trondheim.kommune.no/kdp-vann-i-trondheim/tilpasse-til-et-klima-i-endring>

- Tscheikner-Gratl, F. (2022). *Urban Drainage Systems—Lecture in TVM4141 NTNU 2022*.
- VA-norm. (2022). *VA-norm Trondheim Kommune*. Norsk Vann. <http://va-norm.no/pdf/0/all/126/>
- WEF, & EWRI (U.S.) (Eds.). (2012). *Design of urban stormwater controls* (2nd ed). McGraw-Hill Professional ; McGraw-Hill [distributor].
- Wikipedia. (2022). WSUDS. In *Wikipedia*. [https://en.wikipedia.org/w/index.php?title=Water-sensitive\\_urban\\_design&oldid=1124488988](https://en.wikipedia.org/w/index.php?title=Water-sensitive_urban_design&oldid=1124488988)

## Appendix I

### Calculation of excess rainfall

Following are two jupyter notebooks which calculate the P\_design event of the historical and the two future precipitation timeseries. The calculations shown are calculations for P\_design each year, however the code has also been used to calculate P\_design for the entire timeseries.

In [3]:

```
import pandas as pd
import numpy as np
import matplotlib.pyplot as plt
import scipy as sp
from scipy.optimize import differential_evolution
import csv
import seaborn as sns

import matplotlib.pyplot as plt
import matplotlib.transforms as transforms
import numpy as np; np.random.seed(42)
```

**Calculate design precipitation** The data set is provided from Vincent, and contains precipitation data from **1987 to 2020** in hourly resolution. The design precipitation is assumed to be the event which leaves 90% of the precipitation to the stormwater system, and 10% to excess (surface).

In [4]:

```
#importing data file
filepath = '1987_2020_hour_res_Prec_Temp.txt'
df_in = pd.read_csv(filepath, sep=',', engine='python', header=0)
#df_in
```

In [5]:

```
#creating a new dataframe which includes split up timestep (using datetime)

df_1 = pd.DataFrame()

df_1['Date'] = pd.to_datetime(df_in['Date']).dt.date
df_1['Time'] = pd.to_datetime(df_in['Date']).dt.time
df_1['Precip [mm]'] = df_in['Precipitation_mm']
#df_1
```



In [8]:

```
#making nice seaborn plot
sns.set()

fig, ax = plt.subplots(figsize = (16,6))
plt.xticks(fontsize = 16)
plt.yticks(fontsize=16)

plt.title('Precipitation events 1987 - 2020', fontsize = 24)
plt.xlabel('Year', fontsize = 20)
plt.ylabel('Precipitation [mm]', fontsize = 20)

plt.plot(df_1['Date'], df_1['Precip [mm]'])
```

Out[8]:

```
[<matplotlib.lines.Line2D at 0x1a8d971bbe0>]
```

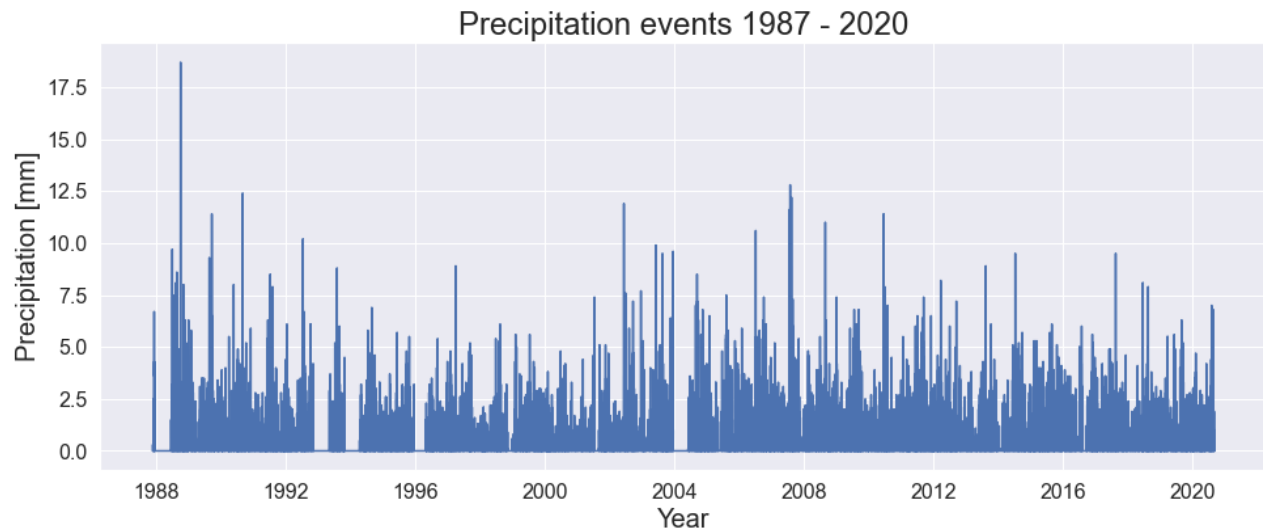

In [11]:

```
#accounting for Leap years

yr = 33
skuddår = 24

time_period = 1986+yr

#not a leap year
df = df_1[(yr-1)*8784-24*skuddår:yr*8784-24*skuddår-24]

#Leap year
#df = df_1[(yr-1)*8784-24*skuddår:(yr*8784)-24*skuddår-24]
#df
```

In [12]:

```
#total precipitation
P_sum = sum(df['Precip [mm]'])

#P which is NOT handled by the system (assume 10% of total)
excess_precip = 0.1*P_sum
```

In [13]:

```
#calculating excess
def excess_vp(threshold, P_data):
    rawExcess = P_data - threshold[0] # vector operation to be faster, has negative value
    excess_P = np.sum(rawExcess[rawExcess>0]) # sum only the positive values
    return excess_P
```

In [14]:

```
def thresh_opt(threshold_list):
    result = np.absolute(excess_precip - excess_vp(threshold_list, df['Precip [mm]']))
    return result
```

**Method 1:** Finding the threshold using differential\_evolution from scipy.

In [9]:

```
def optimized_threshold(resolution, time_period): #resolution = string
    res = resolution
    tp = time_period
    optimized_t = differential_evolution(thresh_opt, bounds=[(0.01,10)], strategy='best1bin')
    return print(f'The optimized threshold (design P event) for {tp} is {round(float(optimized_t.x),4)} {res}')
```

In [10]:

```
res = 'mm/hr'
optimized_threshold(res, time_period)
```

The optimized threshold (design P event) for 2019 is 1.7019 mm/hr

In [11]:

```
#importing data file of P_design for each year
file = 'P_design_per_yr_hr_1987-2020.csv'
df_P_yr = pd.read_csv(file,sep=';', engine = 'python', header = 0)
#df_P_yr
```

In [12]:

```
#value for P_design for the whole timeseries
whole_ts = 1.9583

#making nice seaborn plot
sns.set()

fig, ax = plt.subplots(figsize = (15,5))

ax.bar(df_P_yr['Starting year'],df_P_yr['P_design [mm/hr]'], width = 0.8, label = 'P_design for each year')
ax.axhline(y = 1.9583, color = 'r', linestyle = 'dashed', label = 'P_design 1987-2020')

plt.ylabel('Design event [mm]', fontsize = 14)
plt.xlabel('Year', fontsize = 14)
plt.xticks(df_P_yr['Starting year'], rotation = 90)
plt.title('Design precipitation events for the years 1987-2020', fontsize = 18)

#adding the lable on the red line
trans = transforms.blended_transform_factory(
    ax.get_yticklabels()[0].get_transform(), ax.transData)

ax.text(0,whole_ts, '1.9583', color="red", transform=trans,
        ha="left", va="center_baseline")

#-----
plt.legend()
plt.show()
```

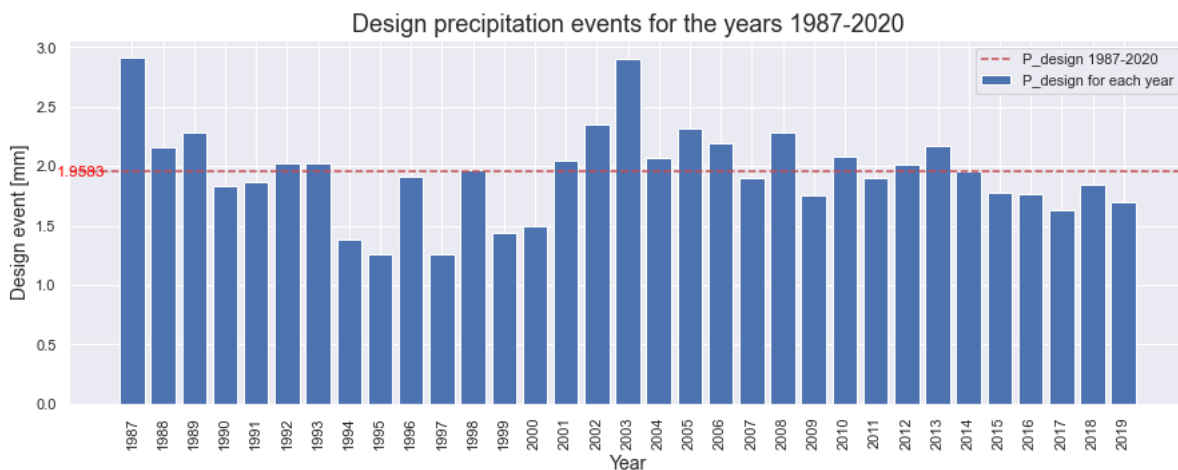

## Calculation of excess rainfall: future

In [8]:

```
import pandas as pd
import numpy as np
import matplotlib.pyplot as plt
import scipy as sp
from scipy.optimize import differential_evolution
import csv
import seaborn as sns
import datetime as dt
from datetime import datetime

import matplotlib.pyplot as plt
import matplotlib.transforms as transforms
import numpy as np; np.random.seed(42)
```

**Calculate design precipitation** The data set is provided from Vincent, and contains precipitation data from **2071 ro 2099** in hourly resolution. The design precipitation is assumed to be the event which leaves 90% of the precipitation to the stormwater system, and 10% to excess (surface). **The code works for both future time series by changing the input file**

In [9]:

```
#getting file, using date as index, parse_dates makes the date into date_time
filepath = '2071_2099_hour_res_Prec_Temp_model0.txt'
df_1= pd.read_csv(filepath,sep=',', engine = 'python', header = 0, index_col=0, parse_dates=[0])
#df_1
```

In [10]:

```
#getting file, using date as index, parse_dates makes the date into date_time
filepath = '2071_2099_hour_res_Prec_Temp_model0.txt'
df_in= pd.read_csv(filepath,sep=',', engine = 'python', header = 0, parse_dates=[0])
#df_in
```

In [11]:

```
#creating a new dataframe which includes split up timestep (using datetime)

df_plot = pd.DataFrame()

df_plot['Date'] = pd.to_datetime(df_in['Date']).dt.date
df_plot['Time'] = pd.to_datetime(df_in['Date']).dt.time
df_plot['Precip [mm]'] = df_in['Precipitation_mm']
#df_plot
```

In [12]:

```
#making nice seaborn plot
sns.set()

fig, ax = plt.subplots(figsize = (16,6))
plt.xticks(fontsize = 16)
plt.yticks(fontsize=16)

plt.title('Precipitation events model 0, 2071-2099', fontsize = 24)
plt.xlabel('Year', fontsize = 20)
plt.ylabel('Precipitation [mm]', fontsize = 20)

plt.plot(df_plot['Date'], df_plot['Precip [mm]'])
```

Out[12]:

```
[<matplotlib.lines.Line2D at 0x24f595cd940>]
```

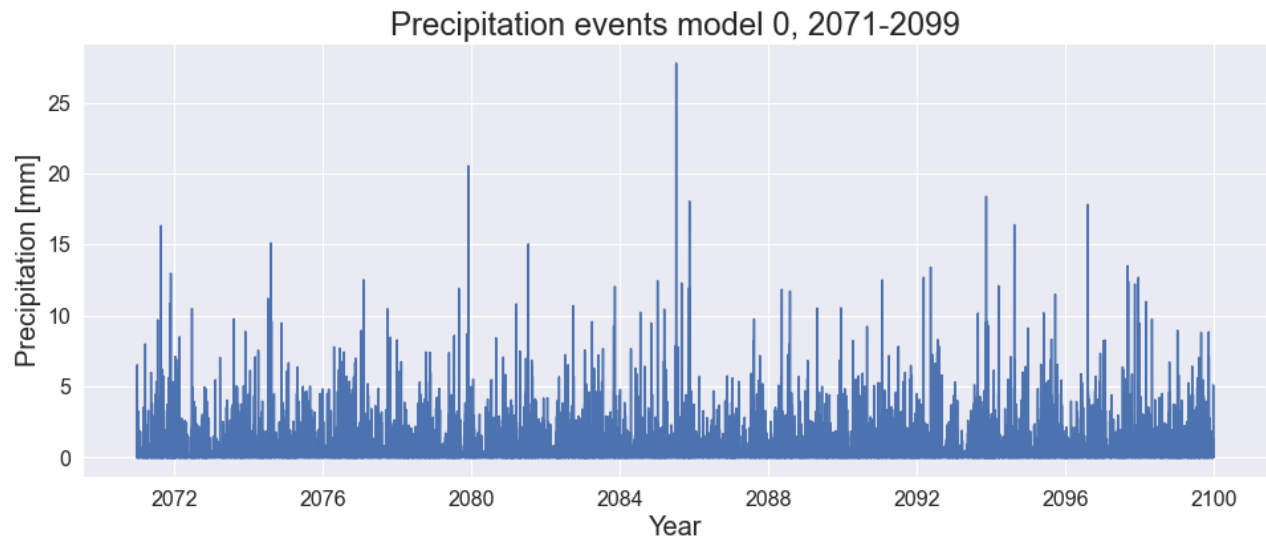

In [14]:

```
#total precipitation
P_sum = sum(df_1['Precipitation_mm'])

#P which is NOT handled by the system (assume 10% of total)
excess_precip = 0.1*P_sum
```

In [15]:

```
#vincent
def excess_vp(threshold, P_data):
    rawExcess = P_data - threshold[0] # vector operation to be faster, has negative value
    excess_P = np.sum(rawExcess[rawExcess>0]) # sum only the positive values
    return excess_P
```

In [20]:

```
def thresh_opt(threshold_list):
    result = np.absolute(excess_precip - excess_vp(threshold_list, df_1['Precipitation_mm']))
    return result
```

**Method 1:** Finding the threshold using differential\_evolution from scipy.

In [21]:

```
def optimized_threshold(resolution, time_period): #resolution = string
    res = resolution
    tp = time_period
    optimized_t = differential_evolution(thresh_opt, bounds=[(0.01,10)], strategy='best1bin')
    return print(f'The optimized threshold (design P event) for {tp} is {round(float(optimized_t.x),4)} {res}')
```

In [22]:

```
res = 'mm/hr'
#time_period = '2071-2099'
optimized_threshold(res, time_period)
```

The optimized threshold (design P event) for 2099 is 2.4124 mm/hr

In [23]:

```
#importing data file of P_design for each year
file = 'P_design_per_yr_hr_2071-2099_M0.csv'
df_P_yr = pd.read_csv(file,sep=';', engine = 'python', header = 0)
#df_P_yr
```

In [24]:

```
#value for P_design for the whole timeseries
whole_ts = 2.4124

#making nice seaborn plot
sns.set()

fig, ax = plt.subplots(figsize = (15,5))

ax.bar(df_P_yr['Year'],df_P_yr['P_design [mm/hr]'], width = 0.8, label = 'P_design for each year')
ax.axhline(y = whole_ts, color = 'r', linestyle = 'dashed', label = 'P_design 1987-2020')

plt.ylabel('Design event [mm]', fontsize = 14)
plt.xlabel('Year', fontsize = 14)
plt.xticks(df_P_yr['Year'], rotation = 90)
plt.title('Design precipitation events for the years 1987-2020', fontsize = 18)

#adding the Lable on the red Line
trans = transforms.blended_transform_factory(
    ax.get_yticklabels()[0].get_transform(), ax.transData)

ax.text(0,whole_ts, str(whole_ts), color="red", transform=trans,
        ha="left", va="top")

#-----
plt.legend()
plt.show()
```

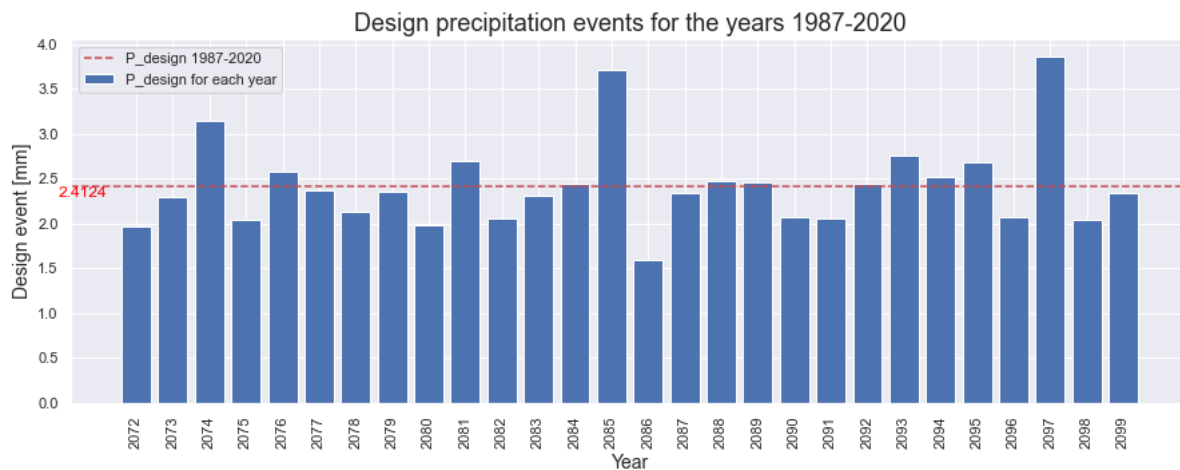

## Appendix II: Rain garden area calculations

This dokument aims to calculate the area of rain garden needed to handle the design precipitation events found in the file 'P\_design\_total\_per\_yr.csv'

In [28]:

```
import pandas as pd
import numpy as np
import matplotlib.pyplot as plt
```

The formula for area of a raingarden:

$$A = \frac{A_{drain} \times C \times P \times d_f}{K_{sat} \times t_f \times (h_f + d_f)}$$

$A$  is the raingarden surface area [m<sup>2</sup>]

$A_{drain}$  is the area of the connected drainage area [m<sup>2</sup>]

$C$  is the average runiff coefficient of the drainage area [-]

$P$  is the design precipitation event [cm]

$d_f$  is the depth of the filter media [cm]

$K_{sat}$  is the saturated hydraulic conductivity of the filter media, cm/hr

$h_f$  is the average height of water above filter bed [cm]. Typically:  $h_f = \frac{1}{2} h_{max}$

$t_f$  is the drainage time

In [29]:

```
#getting the values for P_design [cm/hr]
filepath = 'Fra Vincent/P_design_total_per_yr.csv'
df = pd.read_csv(filepath, sep = ';')
```

In [30]:

```
#extracting the P_design values
P_mm_hr = list(df['P_design[mm/hr]'])
P_cm_hr = []

for i in range(3):
    P_cm = P_mm_hr[i]/10
    P_cm_hr.append(round(P_cm,5))
```

In [31]:

```
#parameter data
A_drain = 52192.422 # [m2]takareal, fra GIS
C = 0.9 # average runoff coef, fra paper

#fra Risvollan
d_f = 75 # cm depth of filter media
K_sat = 10 # cm/hr Saturated hydraulic conductivity
h_max = 16 #[cm]
t_f = 1 #hour bc of small catchment with little to no delay bc of travel time
```

In [32]:

```
#calculation of the needed rain garden area for each of the P_design
def A_rain_garden(A_drain,C,d_f,K_sat,P_cm_hr,h_max,t_f):
    h_f = 0.5*h_max # average height of water above filter bed [cm]
    A_list= []

    for i in range(len(P_cm_hr)): #P_cm_hr = t_f
        A = (A_drain*C*d_f*P_cm_hr[i])/(K_sat*t_f*(h_f+d_f))
        A_list.append(A)

    return A_list
```

In [33]:



```
A_rain_garden(A_drain,C,d_f,K_sat, P_cm_hr ,h_max, t_f)
```

Out[33]:

```
[831.2130542380121, 1023.9587254474699, 1045.0117650686745]
```



 **NTNU**

Norwegian University of  
Science and Technology