



# Estimating financial compensation and minimum guaranteed charge for vehicle-to-grid technology

Milad Mehdizadeh<sup>\*</sup>, Trond Nordfjaern, Christian A. Klöckner

Norwegian University of Science and Technology (NTNU), Trondheim, Norway

## ARTICLE INFO

### Keywords:

Vehicle-to-Grid  
Financial compensation  
Minimum guaranteed charge  
Electric vehicle  
Energy policy  
Multi-equation econometric model

## ABSTRACT

Electric vehicles (EVs) can play an ancillary role in energy and electricity system management. Vehicle-to-Grid (V2G) technology allows EV batteries to be discharged back into the grid. This technology enables charging when electricity prices are low and there is abundance of electricity in the grid and discharging when electricity costs are high and there is high load in the grid. The current study estimates the combination of financial compensation (FC) incentives (reduction in monthly electricity bill) and minimum guaranteed charge (MC) that would be needed to increase the acceptance of V2G technology among Norwegians. Estimating a multi-equation econometric model, we investigate how socioeconomic, geographical, and psychological exogenous variables predict the level of FC and required MC, as well as the relationship between FC and MC. We found that there is a mutual and negative relationship between FC and MC. Based on the MC-FC economic relationship, the V2G system is more likely to be accepted by older people, people who perceive the V2G system as more useful, people who have EV experience, and individuals with a higher level of trust in the V2G system. The group with strong trust in V2G demands less FC for a given value of MC. When MC is reduced, younger age groups (18–22) are more likely to demand higher FC. Our estimations also show that people demand an average reduction in electricity bills of 144 USD (72% of the average monthly electricity bill) as compensation for V2G investment while they would also use V2G if their electric car's battery had a minimum level of 71% power. Monetary incentives based on socioeconomic status, options in the interface allowing the user to easily override the standards, and trusted methods of calculating the revenue may be considered in order to reduce financial expectations and concerns regarding minimum battery charges.

## 1. Introduction

Climate change can be mitigated by electrifying the transportation sector (Sugiyama, 2012). A vehicle that runs on electricity emits fewer greenhouse gases over its lifetime than a vehicle that runs on fossil fuels (Fernández, 2018). It is predicted that by 2030, there will be 150–250 million Electric Vehicles (EVs) worldwide (IEA, 2020), up from 10 million in 2021. For instance, in Norway which is a leading nation in EV uptake (Mersky et al., 2016), the battery EV market shares in 2021 reached 64%.<sup>1</sup> According to the Norwegian government's national transport plan (Norwegian Ministry of Transportation, 2017), the aim is that all new passenger cars sold from 2025 will be zero-emission vehicles (electric cars and hydrogen cars). This will further increase penetration of EVs in the new passenger car market and contribute to an acceleration of the green shift in passenger transportation.

EVs have also been credited with playing a new role (an ancillary service) in energy and electricity system management. It has been argued that EVs may be able to function as batteries for the electricity grid, as well as deliver two-way electricity streams, if Vehicle-to-Grid (V2G) technology will be developed (Guille and Gross, 2009). This is of great value for the electricity grids as these potentially huge battery capacities can be used to balance the system in peak and off-peak hours. A V2G system allows EV batteries to be discharged back into the electricity grid (Aasbøe, 2021; Geske and Schumann, 2018; Parsons et al., 2014). EVs with V2G capabilities can charge/discharge economically - charging when electricity prices are low and there is abundance of electricity in the grid and discharging when electricity costs are high and the grid is under pressure. Parked EVs can thus act as a reserve power source for the electricity grid if such a solution is used. Through the V2G interface, grid operators can maintain stable voltages and frequencies

<sup>\*</sup> Corresponding author. Norwegian University of Science and Technology (NTNU) Bygg 12, 579, Dragvoll, Trondheim, Norway.

E-mail address: [milad.mehdizadeh@ntnu.no](mailto:milad.mehdizadeh@ntnu.no) (M. Mehdizadeh).

<sup>1</sup> <https://elbil.no/english/norwegian-ev-policy/>.

within a short timeframe, thus ensuring a reliable energy supply and potentially reduced public costs related to grid expansions. EV batteries, which use lithium-ion cells, are highly efficient and quick to respond, making them ideal for grid regulation as they can quickly correct imbalances (Aasbøe, 2021). When EVs are equipped with V2G-enabling technology, they will be able to provide reserve service at a lower cost, and the owners of EVs may be able to get paid for it.

So far, several studies have tried to identify barriers and incentives for consumer acceptance to participate in the V2G service. Previous research has found the following factors to be more or less important in the acceptance of the V2G system (e.g., Geske and Schumann, 2018; Kester et al., 2018; Noel et al., 2019; Zonneveld, 2019; Meijssen, 2019; Schmalfuß et al., 2015; van Heuveln et al., 2021; Gong et al., 2021; Huang et al., 2021): financial compensation (e.g. discount on charging/parking tariff), the anxiety of being left with a car not sufficiently charged for trip length requirements, beliefs regarding battery degradation, the ease of use of the user interface on the charging station, keeping control over charging or discharging, V2G charging point location, communication processes for promoting V2G, societal contribution to sustainable energy, and user-friendliness of the whole system.

Among these factors, however, two core variables, financial compensation and the minimum guaranteed charge of the battery at any given time, are frequently cited as the most critical affecting the public acceptability of the V2G system in different countries (e.g., van Heuveln et al., 2021; Geske and Schumann, 2018; Meijssen, 2019; Huang et al., 2021). Financial Compensation (FC) refers to any kind of monetary compensation from a power aggregator/V2G operators such as a discount on an electricity bill or charging/parking tariff to motivate users to participate in the V2G service. Minimum guaranteed Charge (MC) refers to concern about the availability of sufficient battery capacity in EVs to be operated as usual in daily activities. Some users may have concerns regarding the minimum guaranteed charge in EV batteries when enabling V2G services.

Despite the importance of FC and MC, however, little is known about (i) how these factors influence each other and are influenced by other exogenous variables, and (ii) what sociodemographic groups, geographical features, and psychological factors predict FC and MC. We address these research gaps through a study among a stratified random sample of Norwegians since Norway is a leading nation in EV uptake. Addressing these questions can have policy implications. Through the analysis of FC and MC, policymakers and V2G operators are able to gain a better understanding of who is more likely to request higher FC and report higher MC. This can provide policymakers with insights regarding the optimal price (monetary incentive) level for that service as well as the minimum charge level to be guaranteed to reach broad acceptance. From an economic perspective, it can be assumed that there can be a close relationship between FC and MC. The two aspects (minimum charge and financial compensation) are not independent of each other, e.g., if the requested minimum charge is always 100%, one only may want to be compensated for the battery degradation; if the requested minimum charge is 0%, then one may claim compensation for being able to pay for other transport modes. Therefore, we analyse the influence of these factors on each other as well. According to this postulation, a V2G contract at 100% MC and  $FC = 0$  can be considered acceptable provided that users (i) trust the V2G operators, (ii) do not ask for reimbursement for battery degradation/or for letting someone steer their charging behaviour, and (iii) do not want always a safety net for MC. Concerning the prediction of FC and MC, each variable functions as an endogenous factor in the model, which is influenced by exogenous variables, and affects the dependent variable of the other at the same time.

A closer look at the literature reveals that no studies have estimated both FC and MC as a multi-equation system considering sociodemographic, geographical, and psychological factors. However, a few previous studies aimed to estimate willingness-to-pay (WTP) for EVs with V2G contracts, and one study estimated willingness-to-accept (WTA) values for the V2G service. As asserted by Lee et al. (2020), since

potential consumers can earn revenue by participating in a V2G service, the WTA should be gauged for a V2G service rather than WTP. Lee et al. (2020) argued that V2G services provide consumers with a way to earn revenue by enduring varying inconveniences, which is different from a general product or service. As a result of connecting their vehicles to the grid, vehicle owners may experience a reduction in utility when subscribing to a V2G service. As a result, the WTA method is a better approach for measuring the economic value of a V2G service than the WTP method (Lee et al., 2020). Employing an online survey based on a contingent valuation approach, Lee et al. (2020) estimated WTA for V2G services in South Korea. According to them, the mean WTA per vehicle was USD 8.83 per month. Up until July 2022, only 1.2 percent of South Korean vehicles were electric.<sup>2</sup> This may explain why WTA for V2G was very low, since people might not know exactly what they assessed. They also found that respondents who were older were more likely to accept presented amounts than those who were younger. Additionally, people who were more familiar with the V2G were more likely to accept a suggested amount.

Using stated preference data, Parsons et al. (2014) estimated potential consumer demand for V2G EVs. They found that consumers prefer payment-as-you-go or in-advance cash payments for V2G services to fixed requirements from power aggregators. With various battery cost scenarios and using a web-based survey, Hidrue and Parsons (2015) compared consumers' WTP with the calculated battery cost of a V2G service in the USA. They found that WTP estimates were significantly lower than calculated costs in all scenarios. The authors speculated that minimum guaranteed charge may have accounted for this result. However, no studies have estimated MC and its predictors.

### 1.1. Our study's contributions

We contribute to the state of the art of the V2G research by (i) estimating financial compensation and minimum guaranteed charge for V2G technology as a multi-equation econometric system in Norway. In such an approach, FC and MC each play an endogenous role in the model that is influenced by exogenous variables and at the same time affects the other dependent variable, i.e. MC and FC, respectively. Our study may provide more realistic estimations than previous studies as EV technology is more common knowledge in Norway than the majority of settings included in previous studies, and (ii) investigating the relative roles of three kinds of exogenous (independent) variables (demographic and socioeconomic, geographical, and psychological variables) on the level of financial compensation and minimum guaranteed charge. Generally speaking, we seek to understand which of these variables can significantly influence the level of financial compensation and minimum guaranteed charge in a multi-equation system.

We do not hypothesise a certain direction for the effects of some exogenous variables, since little is known about their associations with FC and MC. However, we hypothesise that there can be a negative relationship between FC and MC in our multi-equation econometric system. Regarding demographic and socioeconomic attributes, for example, we hypothesise that younger people request higher financial compensation. Due to lower-income or less stabilised job situations (Lee et al., 2020), young participants may expect more financial compensation compared to their older counterparts. In contrast, older individuals may report a higher level of required minimum charge. This hypothesis is based upon the proposition that older individuals may be less likely to have unexpected extra trips than their younger counterparts (Collia et al., 2003). Some studies have also shown that youngsters tend to be less risk-sensitive than older ones (e.g., Barber and Kim, 2021). We also hypothesise that people with higher incomes may be less likely to demand higher FC than those with lower incomes. This hypothesis is based on that those who have a high income have fewer economic issues to

<sup>2</sup> <https://www.koreaherald.com/view.php?ud=20220731000133>.

contend with when seeking monetary compensation.

We also investigate whether geographical regions (people from the southeast, west, mid-region, and north of Norway) differ in their levels of FC and MC. We hypothesise that for people who are living in the north, V2G may be less attractive due to the colder climate and poorer charging infrastructure as well as poorer road infrastructure and large distances, encouraging people to request higher compensation or higher battery capacities.

We also hypothesise that several psychological factors, such as perceived usefulness and perceived ease of use of the V2G system, trust in the V2G service, favourable attitudes and norms towards the V2G system, and vehicle battery concerns, can be possible predictors of FC and MC. It was decided to consider these psychological factors as predictors since they have been found relevant in the research literature on technology diffusion (van Heuveln et al., 2021). According to Davis (1989) Technology Acceptance Model (TAM), perceived usefulness (PU), and perceived ease of use (PEU) to some extent explain user acceptance and different behaviour regarding the use of technology. As defined by the TAM model, perceived ease of use refers to “the degree to which the prospective user expects the system to be trouble-free” (Davis, 1989, p.319), whereas perceived usefulness refers to the extent to which a technology is expected to improve a potential user’s performance (Davis, 1989). For instance, we hypothesise that people with favourable perceptions about usefulness of V2G services are likely to demand less FC.

Due to the fact that conventional combustion engine cars can not be equipped for V2G (and the majority of currently available EVs are also not technically equipped for V2G), we also examine attitudes towards the use of V2G on FC and MC. According to Fishbein and Ajzen (1975) behaviour is not solely determined by attitude. In line with the Theory of Reasoned Action, subject norms (i.e., perceptions of social pressure) also influence behaviour. Thus, we examine how attitudes and subjective norms affect FC and MC. Furthermore, in EV research, it has been reported that vehicle battery concerns, such as concerns about battery degradation over time, and people’s trust in V2G technology and operators impact user behaviour. Therefore, we reveal in this study how concerns over vehicle batteries and trust in V2G services can also influence FC and MC.

To sum up, we aim to investigate the relative roles of demographic and socioeconomic, geographical, and psychological variables on the level of financial compensation and minimum guaranteed charge for V2G service in a multi-equation system. According to Table 1, we also summarised our study variables and a reference to which model/theory or previous research they were taken from.

**Table 1**  
Variables hypothesised to predict FC-MC.

Category	Variable	Model/Theory/Previous research
Demographic and socioeconomic	Age, gender, education, income, EV experience	Lee et al. (2020)
Geographic	Geographical region	–
Psychological	Attitudes toward V2G service	Theory of Reasoned Action by Fishbein and Ajzen (1975)
	Subjective norm regarding V2G service	Theory of Reasoned Action by Fishbein and Ajzen (1975)
	Perceived usefulness of V2G system	Technology Acceptance Model by Davis (1989)
	Perceived ease of use of V2G system	Technology Acceptance Model by Davis (1989)
	Trust	A conceptual model by van Heuveln et al. (2021)
	Vehicle battery concern	A conceptual model by van Heuveln et al. (2021)

## 2. Method

### 2.1. Sample

In November 2021, 1000 Norwegians who had driving licenses completed a self-reported online survey. We employed a random sampling from a survey panel, stratified by region in Norway, age, and gender. The data were collected from all 11 counties in Norway. A multiple imputation method was applied to replace missing values with an estimate in this study. All participants were informed that the survey was voluntary and that their data would remain anonymous throughout. 51% of the participants were female. A total of 7% of respondents were 18–22 years old, 22% were 23–35 years old, 39% were 36–55 years old, and the rest were older than 55.

The characteristics of the sample were compared with those of the population using the latest official statistics in Norway (Statistics Norway, 2021). In general, the characteristics of the sample correspond to the characteristics of the population. For instance, about 50% of Norwegians older than 16-year-old are female, which is very close to our sample’s percentage of females (see Appendix A for more detailed comparisons). In addition, the geographical distribution of our sample is consistent with Norwegian population statistics. As an example, Viken has the highest percentage of respondents in our sample with 22.3% of its residents living in this county which is Norway’s most populous county.

### 2.2. Measurement

The questionnaire of this study was part of a larger survey that was conducted to investigate the progress of mobility innovation in Norway. Researchers proficient in both Norwegian and English developed and translated several validated English scales into Norwegian. An explanation of V2G technology (in simple language) was provided in the survey’s V2G section. We explained that “Vehicle-to-grid (V2G) is a system where electric vehicles will be able to transfer electricity back to the power network. The battery of the car will charge when power is cheap and will return power to the network during high traffic/peak hours saving both energy and money.”

Using stated preference (SP) techniques, we evaluated financial compensation and minimum guaranteed charge. One of the most commonly used SP methods is contingent valuation. It has been demonstrated that contingent valuation can be used to obtain reliable information about consumer potential demand for innovations, especially at the start of diffusion (Arrow et al., 1993; Yoo and Moon, 2006; Lee et al., 2020). According to contingent valuation methods, respondents are asked how much money or value they are willing to receive in exchange for losing (or continuing to have) a service. To measure FC, the following question was asked: “How large a reduction in your monthly electricity bill would be needed to compensate for your investment in V2G?” Also, to evaluate MC, we asked another question: “To which minimum level (in percent) do you want the electric car always to be charged to when you start using it when allowing V2G?”

In another part of the survey, demographic (age, gender) and socioeconomic variables (education level, income status, EV experience) were recorded. We also asked respondents to report which county in Norway they were living in.

In the part of the survey containing psychological measures, we asked for agreement to different statements on a 5-point Likert scale (1 = strongly disagree; 2 = disagree; 3 = neither disagree nor agree; 4 = agree; 5 = strongly agree). Two items such as “A monetary compensation (e.g., free parking, discount on charging) encourages me to use V2G” were used to evaluate the perceived usefulness of V2G. Perceived ease of use was assessed by two items such as “I think that using a V2G system is simple for the end-user”. Attitudes towards V2G technology were evaluated by two statements such as “I think that V2G is a good technology”. Two items such as “I think people who are important to me

want me to use V2G” were administered to measure subjective norm. Two indicators were used to assess trust in V2G, for instance, “I trust V2G system designers”. Furthermore, concern over vehicle battery was measured by two items such as “I think that the V2G system can lead to battery degradation in the long term”. Most of the psychological items were validated and tested in previous research (van Heuveln et al., 2021).

2.3. Multi-equation econometric modelling

To investigate the relative roles of demographic and socioeconomic variables, geographical regions, and psychological factors on FC and MC, a multi-equation econometric model was tested (Wisniewski, 2015). To avoid estimation bias from correlated variables the model was estimated with the Two-Stage Least Squares (2SLS) method.

As illustrated in Fig. 1, consider the system of endogenous variables, denoted by FC and MC, and *i* exogenous variables, denoted by  $X_1, X_2, \dots, X_i$ . The system can be modelled as a set of two equations, where the endogenous variables are linearly related to the exogenous variables and each other, along with an error term:

$$FC = \alpha_1 + \beta_1 MC + \gamma_{11} X_1 + \gamma_{12} X_2 + \dots + \gamma_{1i} X_i + u_1 \tag{1}$$

$$MC = \alpha_2 + \beta_2 FC + \gamma_{21} X_1 + \gamma_{22} X_2 + \dots + \gamma_{2i} X_i + u_2 \tag{2}$$

where,

- $\alpha_1$  and  $\alpha_2$  are the intercepts,
- $\beta_1$  and  $\beta_2$  are the coefficients of the endogenous variable MC and FC, respectively,
- $\gamma_{11}$  to  $\gamma_{1i}$  and  $\gamma_{21}$  to  $\gamma_{2i}$  are the coefficients of the exogenous variables  $X_1$  to  $X_i$ , and
- $u_1$  and  $u_2$  are the error terms.

We identify *k* instruments for the endogenous variables. In the first stage, we estimate the following reduced-form equations:

$$\widehat{MC} = \delta_1 + \lambda_1 Z_1 + \lambda_2 Z_2 + \dots + \lambda_k Z_k + \eta_1 \tag{3}$$

$$\widehat{FC} = \delta_2 + \lambda_3 Z_1 + \lambda_4 Z_2 + \dots + \lambda_{(k+2)} Z_k + \eta_2 \tag{4}$$

where,

- $Z_1, Z_2, \dots, Z_k$  are the *k* instruments for the endogenous variables,
- $\delta_1, \delta_2, \lambda_1, \lambda_2, \dots, \lambda_{(k+2)}$  are the coefficients on the instruments, and
- $\eta_1$  and  $\eta_2$  are the error terms.

In the second stage, we use the predicted values from the first-stage regressions (reduced forms) as instruments (predictors) in Equations (1) and (2).

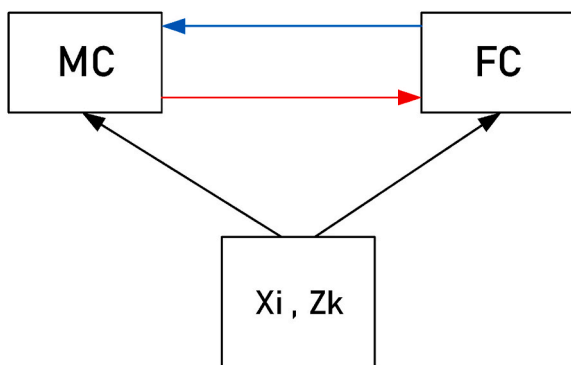

Fig. 1. The multi-equation econometric system of the current study.

3. Results

3.1. Financial compensation and minimum guaranteed charge

The scatter plot as a two-dimensional plot was used to investigate how FC may be related to MC. As illustrated in Fig. 2, this plot is a graphical representation of the relationship between these two variables. Each point on the plot represents a pair of values for the two variables, with the x-value corresponding to the FC and the y-value corresponding to the MC. For example, around 29% of the points (the combination of values for the two variables in the data) are in the range of the following combination ( $FC \leq 114 USD, MC \geq 60\%$ ). The shape of the scatter plot can indicate the strength and direction of the relationship between the two variables. It seems that a negative relationship exists when the values of one variable decrease as the values of the other variable increase. The correlation analysis also shows that these two variables are statistically ( $r = -0.22, p < 0.05$ ) correlated. But, this correlation does not imply causation, and other factors could also be influencing the relationship between FC and MC. A multi-equation econometric model would be needed to rule out other possible factors that may be influencing the relationship.

3.2. Multi-equation econometric model explaining FC and MC

As described in section 2.3, a multi-equation model was systematically developed and tested. Firstly, we found that both FC and MC had continuous nature and followed a normal distribution. Skewness and kurtosis values for both FC and MC are between  $-2$  and  $+2$ , meaning that these variables follow a normal distribution.

Demographic and socioeconomic variables, geographical, and psychological factors were tested as exogenous and instrumental variables in the modelling approach. Table 2 shows the mathematical definitions of these variables. Variables were tested in various formats, including continuous, ordinal, nominal, and dummy. Most variables with dummy coding showed a statistically significant association and improved model fit. For example, people who had a university degree are called high-educated (*HighEdu*) and represented by using a dummy variable. Using a dummy variable, those who reported income above the Norwegian average (587,600 NOK or 67,274 USD) are referred to as high-income (*HighIncome*) participants. The proportions of participants who are highly educated and have high income are 52% and 23%, respectively. Since the share of participants from some counties was low, we

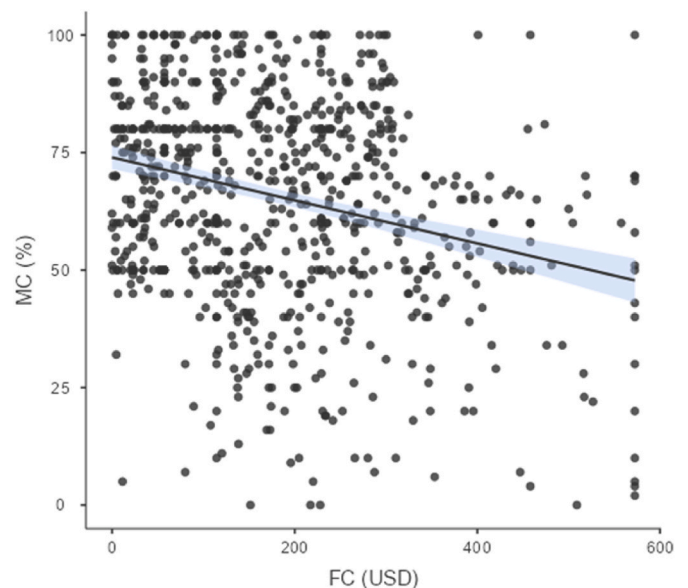

Fig. 2. Scatterplot of the MC-FC relationship.

**Table 2**  
Variables tested in the analyses.

Variable,	The question used to measure, descriptive/scale	Mean	SD
<b>Demographic and socioeconomic</b>			
Age,	How old are you? Ranging from 18 to 80	47.67	16.87
Age 1822	1: Age of [18–22], 0: Otherwise	0.07	0.24
Age 2335	1: Age of [23–35], 0: Otherwise	0.22	0.41
Age 3655	1: Age of [36–55], 0: Otherwise	0.39	0.48
Age 5680	1: Age of [56–80], 0: Otherwise	0.32	0.46
Female,	What is your gender? 1: The respondent is a female; 0: otherwise	0.51	0.50
HighEdu	What is the highest level of education you have completed? 1: The respondent has a university degree; 0: otherwise	0.52	0.50
HighIncome	How is your annual income compared to the average in Norway? 1: The respondent's annual income is greater than the average in Norway (587,600 NOK <sup>a</sup> or 67,274 USD); 0: otherwise	0.23	0.41
ExprienceEV	Do you have access to an electric car? 1: The respondent experienced EV driving; 0: otherwise	0.30	0.45
<b>Geographical region</b>			
SouthEast	Which county do you live in? 1: The respondent lives in one of the following counties: Oslo, Viken, Innlandet, Vestfold/Telmark; 0: otherwise	0.53	0.49
West	1: The respondent lives in one of the following counties: Vestland, Rogaland, Agder; 0: otherwise	0.27	0.44
MidRegion	1: The respondent lives in one of the following counties: Trøndelag, Møre and Romsdal; 0: otherwise	0.11	0.31
North	1: The respondent lives in one of the following counties: Nordland, Troms/Finnmark; 0: otherwise	0.09	0.28
<b>Psychological factors</b>			
PU (Perceived Usefulness)	PU1: A monetary compensation (e.g., free parking, discount on charging) encourages me to use V2G. PU2: I think that the V2G can contribute to sustainability. 1: The mean score of PU is 4 or greater than 4; 0: otherwise	0.35	0.47
PEU (Perceived Ease of Use)	PEU1: I want to keep control of the V2G system by using a smartphone. PEU2: Charging or discharging of the battery in the electric car should be controllable in the V2G system. 1: The mean score of PEU is 4 or greater than 4; 0: otherwise	0.29	0.45
ATT (Attitudes)	ATT1: I think that V2G is a good technology. ATT2: I think that using the V2G can be beneficial for me. 1: The mean score of ATT is 4 or greater than 4; 0: otherwise	0.30	0.45
SN (Subjective Norm)	SN1: I think people who are important to me want me to use the V2G system. SN2: I think my social network encourages me to use the V2G system. 1: The mean score of SN is 4 or greater than 4; 0: otherwise	0.16	0.39
TRUST (Trust)	TRUST1: I trust V2G system designers. TRUST1: I think that V2G is a reliable system. 1: The mean score of TRUST is 4 or greater than 4; 0: otherwise	0.23	0.42
VBC (Vehicle Battery Concern)	VBC1: I think that the V2G system can lead to battery degradation in the long term. VBC2: When using the V2G system I would be worried about the battery capacity in my electric car. 1: The mean score of VBC is 4 or greater than 4; 0: otherwise	0.25	0.43

<sup>a</sup> Average annual earnings in 2020. At the time of writing, 1 NOK (Norwegian Krone) was worth around 0.11449 USD dollars.

aggregated 11 counties into four larger geographical regions: southeast (Oslo, Viken, Innlandet, Vestfold/Telemark), west (Vestland, Rogaland, Agder), mid-region (Trøndelag, Møre and Romsdal), and north (Nordland, Troms/Finnmark). In addition, all psychological predictors including perceived usefulness (*PU*), perceived ease of use (*PEU*), attitudes (*ATT*), subjective norm (*SN*), trust (*TRUST*), and vehicle battery concern (*VBC*) were defined in the models by dummy variables.

Table 3 shows the results of the multi-equation econometric model explaining FC. Firstly, different variables were tested as potential instrumental variables for the endogenous variable (*MC*) in the reduced-form equation of this model. After testing different combinations of variables, six psychological variables retained in the reduced form model predicting *MC* as the endogenous variable. At the same time, seven variables including  $\widehat{MC}$ , Female, Age, HighEdu, HighIncome, ExprienceEV, and *PU* were selected as the predictors of FC. It was estimated that the variables explained 11% of the variance. According to this model, higher *MC* ( $p < 0.05$ ) statistically predicted lower FC. Among other exogenous variables, only age ( $p < 0.05$ ) and perceived usefulness ( $p < 0.001$ ) were significantly related to the level of financial compensation. Statistically, geographical variables had insignificant effects in the multi-equation model, so they were excluded.

Table 4 shows the results of the multi-equation econometric model explaining *MC*. Different variables were tested as potential instrumental variables for the endogenous variable (*FC*) in the reduced-form equation of this model. After testing different combinations of variables, seven variables retained in the reduced form model predicting *FC* as the endogenous variable. At the same time, eight variables including  $\widehat{FC}$ , *PU*, *VBC*, *PEU*, *ATT*, *SN*, and *TRUST*, and *ExprienceEV* were selected as the predictors of *MC*. It was estimated that the variables explained 10% of the variance. According to this model, higher *FC* ( $p < 0.05$ ) statistically predicted lower *MC*. Among other exogenous variables, only trust ( $p < 0.05$ ) and *EV* experience ( $p < 0.001$ ) were significantly related to the level of minimum guaranteed charge.

To determine *FC* and *MC*, the population/sample average was used. Equation (5) tells us what *FC* level would be required (on population average) given a level of *MC* and other parameters. Equation (6) tells us what *MC* level would be required given a level of *FC* and others. A stationary point is thus a *MC-FC* pair that would be required given its own level. In order to achieve this, the average values of variables in the population<sup>3</sup> and in the sample (as reported in Table 5) were incorporated into the equations as follows:

**Table 3**  
The multi-equation econometric model explaining financial compensation (*FC*).

	Coefficient	Std. Err.	z		[95% conf. Interval]	
$\widehat{MC}$	-4.55	2.26	-2.02	*	-8.98	-12
Female	7.43	9.72	.76		-11.61	26.48
Age	-.81	.34	-2.38	*	-1.48	-.14
HighEdu	13.97	9.74	1.43		-5.12	33.07
HighIncome	-10.98	13.59	-.81		-37.63	15.66
ExprienceEV	-15.39	12.86	-1.20		-40.60	9.82
<i>PU</i>	-37.06	10.09	-3.67	**	-56.84	-17.28
Constant	494.78	136.72	3.62	**	226.82	762.75

Instrumented: *MC*.

Instruments: *PU VBC PEU ATT SN TRUST*.

Note: \*\*, \* = > significance at 1% and 5% level.

<sup>3</sup> According to Appendix A, the population average was used for Female, Age, HighEdu, and ExprienceEV. Using the population income statistics (Statistics Norway, 2021), we use the cumulative percentage of people with *P70* or more for HighIncome (0.45). Since the population did not contain any psychological variables we considered the sample average for the psychological variables.

**Table 4**  
The multi-equation econometric model explaining minimum guaranteed charge (MC).

	Coefficient	Std. Err.	z		[95% conf. Interval]	
$\widehat{FC}$	-.05	.02	-2.14	*	-.010	-.004
PU	-2.09	1.96	-1.07		-5.95	1.75
VBC	-1.68	1.87	-.90		-5.35	1.99
PEU	2.00	2.36	.85		-2.61	6.63
ATT	-.86	2.56	-.34		-5.90	4.17
SN	2.67	2.64	1.01		-2.50	7.85
TRUST	-4.72	2.23	-2.11	*	-9.10	-.34
ExperienceEV	-3.46	1.66	-2.07	*	-6.72	-.19
Constant	81.86	8.03	10.19	**	66.12	97.60

Instrumented: FC.

Instruments: Female Age HighEdu HighIncome ExperienceEV TRUST PEU.

Note: \*\*, \* = > significance at 1% and 5% level.

**Table 5**  
Variable averages in the population/sample used to calculate FC and MC.

Variable	Average	Data source <sup>a</sup>
$\widehat{MC}$	65.90	Sample
Female	0.49	Population
Age	48.46	Population
HighEdu	0.40	Population
HighIncome	0.45	Population
ExperienceEV	0.20	Population
PU	0.35	Sample
$\widehat{FC}$	181.47	Sample
VBC	0.25	Sample
PEU	0.29	Sample
ATT	0.29	Sample
SN	0.16	Sample
TRUST	0.22	Sample

<sup>a</sup> See Appendix A for more information.

$$FC = -4.55\widehat{MC} + 7.43Female - 0.81Age + 13.97HighEdu - 10.98HighIncome - 15.39ExperienceEV - 37.06PU + 494.78 \quad (5)$$

$$MC = -0.05\widehat{FC} - 2.09PU - 1.68VBC + 2PEU - 0.86ATT + 2.67SN - 4.72TRUST - 3.46ExperienceEV + 81.86 \quad (6)$$

These calculations show that participants, on average, demanded a reduction of 144 USD in monthly electricity bills as compensation for investment in V2G. On average, participants in the study also indicated that they would use V2G if car batteries had a minimum power of 71% after providing power to the grid by the V2G service.

#### 4. Discussion

When it comes to predictors of levels of requested financial compensation while accounting for the MC effect, in line with our hypothesis, the results show that younger participants are more likely to request higher monetary compensation than their older counterparts. This finding aligns with a South Korean study (Lee et al., 2020) which reported that older people are less likely to seek monetary compensation for V2G use. Taking into account the effect of MC on FC, a one-year increase in age will result in an expected FC reduction of 0.81 USD. The FC model predicts financial compensation of 167 USD based on the average age of the population for youngsters (20 years old for 18–22), 23 USD more than FC’s expectation (144 USD) based on the average age of the population. As illustrated in Fig. 3a, it is evident that the youngest group (18–22) reduces the negative relationship between MC and FC in comparison with other age groups, meaning that with a decrease in MC, the value of FC will decrease with a milder effect than does the effect of older age groups. This result also implies that, with a decrease in the required MC, the youngest age group (18–22) is more likely to demand

for higher FC, as compared with other age groups.

In line with Lee et al. (2020) who did not find any significant relationship between income level and willingness to accept the V2G service in South Korea, we also did not find a statistically significant effect of income on FC in Norway while accounting for the MC effect. Our hypothesis was that people with higher incomes would be less likely to demand higher FC than those with lower incomes, which is not supported by this finding. However, this simultaneous model shows that people with high incomes are less likely to demand a high reduction in monthly electricity bills as compensation for investment in V2G. This result might be an indirect effect of the battery size people in different income classes would own. Individuals with high income are more likely to own an electric vehicle with a larger battery, implying greater flexibility when using the V2G service, which may explain why they requested lower compensation from the operators. For instance, if an electric vehicle is equipped with a 90 kWh battery, it does not have substantial consequences to contribute some kWhs to the grid as if it has a 45 kWh battery. In our Norwegian sample, other sociodemographic variables, such as gender, education level, and EV experience, did not predict FC after controlling for MC effect. Similarly, Lee et al. (2020) found no gender gap in financial compensation for V2G services.

Regarding geographical regions, contrary to our hypothesis, we did not find any significant relationship between the region of living and FC. Perhaps this result can be explained by the fact that people in most parts of Norway have similar and rather low levels of awareness and experiences regarding such technologies, despite the geographic differences between the north and south, and the coast and inland.

The study’s findings indicate that a few psychological variables have a significant influence on the MC-FC relationship, partially supporting our hypotheses. We found that people who reported strongly perceived usefulness of the V2G service were less likely to request high monetary compensation. Considering the simultaneous effect of MC on FC, FC would decrease by approximately 24 USD if all respondents strongly perceived the usefulness of the V2G system. As shown in Fig. 3b, a slightly smaller range of FC values and MC values has been reported for people who have a strong PU compared to those who have a weak PU. The group with high perceived usefulness demands a lower financial reward than the group with low perceived usefulness for the same value of MC (e.g., MC = 60%). Both PU groups, however, exhibit similar trends in their MC-FC relationships.

On average, people indicated they would allow using V2G if an electric car’s battery contained at least 71% of power at any given time. According to the multi-equation model explaining MC, only EV experience had a significant impact among the sociodemographic variables. People who already had experience with EV driving were more likely to report a lower minimum level of charge state. Other variables including age, gender, education status, and income level, were insignificant variables. Considering the simultaneous effect of FC on MC, EV owners reported 3.46% less MC than non-EV owners. Fig. 3c illustrates that people with experience with EV increase the negative relationship between MC and FC as compared to people without experience with EV. Consequently, when MC is reduced, people with EV experience are less likely to demand higher FC. It is evident that the group with EV experience requires less minimum charge than the group without EV experience for a given value of FC (e.g., FC = 200 USD). Plus, in comparison with people without EV experience, people who have EV experience have a smaller range of FC values. Plötz et al. (2014) argue that EV owners are early adopters of technology (Plötz et al., 2014) and are more likely to seek out information about EV technology in general due to relevance/readiness/salience. As a result, it is possible to conclude that people with EV experience know that a 71% minimum charge is enough for everyday trips.

MC levels were not statistically explained by geographical regions. Among psychological predictors, only trust in the V2G system was found a statistically significant predictor of MC. The group of people with strong trust in the V2G system was less likely to report higher MC.

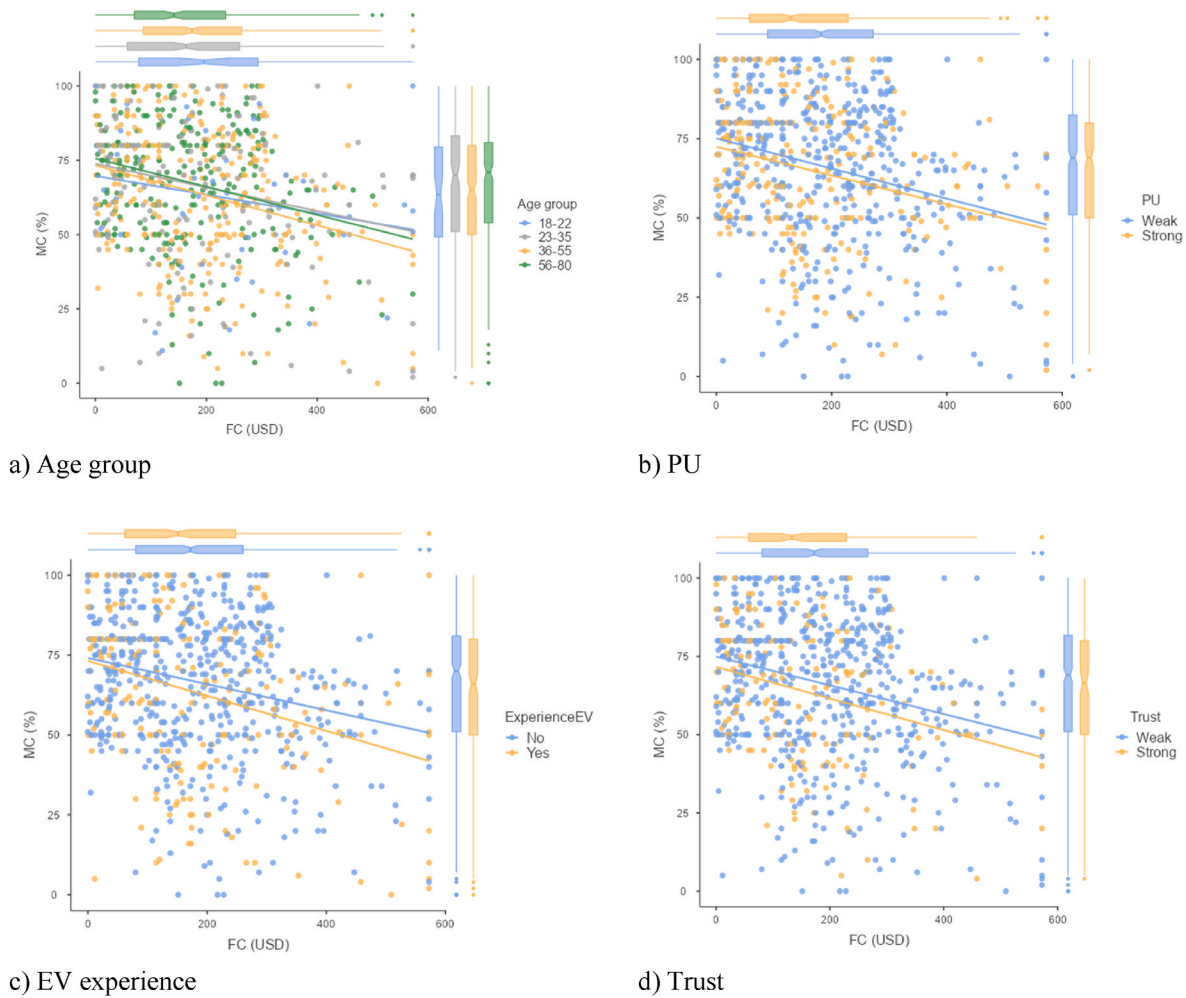

Fig. 3. The effect of significant variables on the relationship between financial compensation and minimum guaranteed charge.

Taking into account the simultaneous negative effect of FC on MC, MC would decrease by approximately 4.72% if all respondents strongly trusted the V2G system. As shown in Fig. 3d, a slightly smaller range of FC values and MC values has been reported for people who have a strong trust compared to those who have a weak trust. For a given value of MC, the group with strong trust in the V2G system demands less financial compensation than the group with weak trust. MC-FC relationships in both trust groups, however, show a similar trend.

4.1. Limitations

Our study is designed using a correlational research design, which is subject to certain limitations. These limitations include the inability to establish causality, the possibility of the third variable problem, restricted generalizability, and measurement error. Using experimental methods could, to some extent, eliminate the limitations associated with correlational studies. Even though EVs are well known in Norway, V2G technology is still regarded as an unknown and uncertain technology. Despite this, V2G technology was evaluated using a contingent valuation method in the current study, which might be better captured by experimental studies. Moreover, the minimum range (MR) in this study was not measured in kilometers, which may have been a useful measure to compare MR in kilometers with the average Norwegian driving range per passenger car. Rather, we measured the minimum guaranteed charge (MC in %) which is related to the battery size in EVs. Since it may be misleading to translate MC in percentage into MR in kilometers, we refrained from discussing how much the required driving range might

be.

5. Conclusion and policy implications

In the current study, a multi-equation econometric model was found to be suitable for estimating minimum guaranteed charges and financial compensations for V2G technology. Based on our economic postulation, the two aspects (minimum guaranteed charge and financial compensation) are not independent of one another. We found that there is a mutual and negative relationship between FC and MC, while these two factors are simultaneously explained by a few exogenous variables. Considering the multi-equation equilibrium, marginal effects show that, in the event of a one-unit increase in MC, the expected FC will be reduced by 5 USD, *ceteris paribus*. Meanwhile, an increase of 1 USD in FC results in a decrease of 0.05 in the required MC, *ceteris paribus*. We found that the MC-FC economic relationship is more likely to be significantly influenced by age, perceiving the V2G system as more useful, having EV experience, and higher levels of trust in the V2G system. In particular, those with a high level of trust in V2G demand less FC for a given amount of MC. In addition, younger age groups (18–22) demand higher FC when MC is reduced.

As compensation for investment in V2G, on average, this Norwegian population-based sample reports a reduction demand in monthly electricity bills of 144 USD. According to the latest statistics (Statbank Norway, 2021), Norwegian households consume on average 1337 kWh of electricity per month. Electricity prices including taxes were 0.15 USD/kWh in the 4th quarter of 2021. Thus, Norwegian electricity bills at

the end of 2021 were about 201 USD. Therefore, the monthly financial compensation for investments in V2G was around 72% of Norwegian average electricity bills. Intuitively, one may attribute the high demands to a sharp increase in electricity prices in Norway, possibly making our respondents considering the compensation for V2G as an opportunity to reduce their energy bills. However, the plausibility of this explanation is reduced by that the electricity prices in Northern Norway remained substantially lower than those in the South and West. Accordingly, we would have expected differences between the Norwegian regions in the north and south if electricity prices really were a core factor for compensation. However, we did not find any significant differences between Northern and Southern Norway. The results of our study indicate that younger individuals are more likely to demand higher financial compensation. The demand for financial compensation would likely decrease by 0.81 USD with a one-year increase in participants' age. In order to efficiently reduce financial compensation regarding use of V2G services, policymakers can use a variable monetary policy based on socioeconomic status. Policymakers could also target older Norwegians, because those who are older are likely to be more wealthy and have modern cars that are most suitable for V2G. A Tesla with a large battery, for example, would be more valuable for grid balancing than a Nissan Leaf with a small battery.

Additionally, we found that trust is a key factor that is associated with lower concerns regarding minimum guaranteed charge. Building trust through options in the interface where the user can easily override the standards for example from 71% charge to 100% in cases where this is needed (e.g., a trip to the cabin) can be a helpful policy. Trusted systems for calculating the revenue can also be effective. Furthermore, we found that people in our sample would use V2G if their electric car's battery had a minimum level of 71% power. We speculate that 71% minimum charge gives the drivers a lot of flexibility. In a modern EV with 65–70 kWh battery capacity, this would be 22–23 kWhs to provide back to the grid. For large battery cars (for which V2G is also technically easier and more efficient), this figure could be even higher. Anyway, taking steps to ensure that users understand the minimum required level of battery charge before operating V2G can help alleviate this concern. It is theoretically possible for cars to know how much they need for business as usual based on their use data. If the system is trusted, these data can be used to balance the loading smartly, including the override for the exceptional days (actually in both directions: One could also let the battery be emptied further if for example one plans to work from home for some time). Moreover, certain power company platforms such as Tibber,<sup>4</sup> for instance, offer smart charging apps that give EV owners a guaranteed 20% reduction in charging costs in exchange for using chargers when prices and grid load are low. Despite the fact that Tibber is not a true V2G system, it is a step towards that system.

Also, we found that people who have never used EVs are more

concerned about minimum guaranteed charges. People who have not yet experienced EVs demand their battery to contain 3.46% more power than those who have. However, the influence of experience on range anxiety should be more deeply analysed in Norway with high EV market penetration rates. The pilot implications of V2G (e.g., by testing the technology among potential end users) may also gain the trust of users and reduce minimum guaranteed charge in the long run. The subjective norms about V2G technology may be activated as a result of such pilot implications.

## Funding

Milad Mehdizadeh is funded by the Norwegian Centre for Energy Transition Strategies (NTRANS) of NTNU (Research Council of Norway to NTRANS, project nr: 296,205).

## Financial disclosure

The study is funded by the Norwegian Centre for Energy Transition Strategies (NTRANS) of NTNU (Research Council of Norway to NTRANS, project nr: 296,205).

## CRediT author statement

Milad Mehdizadeh: Writing – original draft, Writing – review & editing; Conceptualization, Methodology, Investigation, Data curation, Software, Formal analysis, Modelling, Visualization, Project administration, Funding acquisition, Supervision, Trond Nordfjaern: Review & Editing, Resources, Validation, Supervision, Christian A. Klöckner: Review & Editing, Resources, Validation, Project administration, Supervision.

## Declaration of competing interest

The authors declare the following financial interests/personal relationships which may be considered as potential competing interests: Milad Mehdizadeh reports financial support was provided by Norwegian Centre for Energy Transition Strategies.

## Data availability

Data will be made available on request.

## Acknowledgment

The authors would like to thank the reviewers for their comments, particularly regarding improving the estimation model of the study.

## Appendix A

Demographic characteristics of the survey sample and the population.

Characteristic	Population <sup>b</sup>	Survey sample
<b>Gender</b>		
Male	50.2% <sup>c</sup>	49%
Female	49.8%	51%
<b>Age</b>		
18–22 years	8% <sup>c</sup>	7%
23–35 years	22%	22%
36–55 years	34%	39%

(continued on next page)

<sup>4</sup> <https://tibber.com/no/smart-styring/elbillading>.



(continued)

Characteristic	Population <sup>b</sup>	Survey sample
≥ 56 years	36%	32%
The average age of people who are 18 years or older	48.46	47.67
<b>Education</b>		
Highly educated (university degree)	40% <sup>d</sup>	50%
<b>Income</b>		
Median income (P50% or less)	43% <sup>e</sup>	57% <sup>f</sup>
P70% or more	45%	n.a
<b>EV experience</b>		
EV ownership	20% <sup>g</sup>	30%

<sup>b</sup> Statistics Norway, 2021 (ssb.no/en).<sup>c</sup> The population of people who are 18 years or older.<sup>d</sup> For many immigrants, Statistics Norway has no information about their level of education.<sup>e</sup> Student households and children below the age of 18 who are living alone, are excluded.<sup>f</sup> The income of respondents was evaluated in an indirect manner by asking how their annual income compares with the Norwegian average in an interval scale.<sup>g</sup> In 2022, EVs accounted for 20% of Norway's passenger car fleet. According to the Norwegian Electric Vehicle Association, EVs will reach 30 percent of the total fleet in just under two years.

## References

- Aasbøe, T.N., 2021. Importance of Drivers and Barriers for V2G? (Master's Thesis. Norwegian University of Life Sciences, Ås.
- Arrow, K., Solow, R., Portney, P.R., Leamer, E.E., Radner, R., Schuman, H., 1993. Report of the NOAA panel on contingent valuation. *Fed. Regist.* 58 (10), 4601–4614.
- Barber, S.J., Kim, H., 2021. COVID-19 worries and behavior changes in older and younger men and women. *J. Gerontol.: Ser. Bibliogr.* 76 (2), e17–e23.
- Collia, D.V., Sharp, J., Giesbrecht, L., 2003. The 2001 national household travel survey: a look into the travel patterns of older Americans. *J. Saf. Res.* 34 (4), 461–470.
- Davis, F.D., 1989. Perceived usefulness, perceived ease of use, and user acceptance of information technology. *MIS Q.* 319–340.
- Fernández, R.Á., 2018. A more realistic approach to electric vehicle contribution to greenhouse gas emissions in the city. *J. Clean. Prod.* 172, 949–959.
- Fishbein, M., Ajzen, I., 1975. *Belief, Attitude, Intention, and Behavior: An Introduction to Theory and Research.* Addison-Wesley, Reading, MA.
- Geske, J., Schumann, D., 2018. Willing to participate in vehicle-to-grid (V2G)? Why not. *Energy Pol.* 120, 392–401.
- Gong, S., Cheng, V.H.S., Ardeshiri, A., Rashidi, T.H., 2021. Incentives and concerns on vehicle-to-grid technology expressed by Australian employees and employers. *Transport. Res. Transport Environ.* 98, 102986.
- Guille, C., Gross, G., 2009. A conceptual framework for the vehicle-to-grid (V2G) implementation. *Energy Pol.* 37 (11), 4379–4390.
- Hidrué, M.K., Parsons, G.R., 2015. Is there a near-term market for vehicle-to-grid electric vehicles? *Appl. Energy* 151, 67–76.
- Huang, B., Meijssen, A.G., Annema, J.A., Lukszo, Z., 2021. Are electric vehicle drivers willing to participate in vehicle-to-grid contracts? A context-dependent stated choice experiment. *Energy Pol.* 156, 112410.
- IEA, 2020. *Global EV Outlook 2020: Entering the Decade of Electric Drive.* IEA: IEA.
- Kester, J., Noel, L., de Rubens, G.Z., Sovacool, B.K., 2018. Promoting Vehicle to Grid (V2G) in the Nordic region: expert advice on policy mechanisms for accelerated diffusion. *Energy Pol.* 116, 422–432.
- Lee, C.Y., Jang, J.W., Lee, M.K., 2020. Willingness to accept values for vehicle-to-grid service in South Korea. *Transport. Res. Transport Environ.* 87, 102487.
- Meijssen, A., 2019. Dutch Electric Vehicle Drivers' Preferences Regarding Vehicle-To-Grid Contracts: Examining the Willingness to Participate in Vehicle-To-Grid Contracts by Conducting a Context-dependent Stated Choice Experiment Taking into Account the EV Recharging Speed. Master thesis. Delft University of Technology, Delft, the Netherlands. url: [https://repository.tudelft.nl/islandora/object/uuid%3A0cb03a83-148a-48b6-bb14-32a46fdb4e01\\_06/24/2020](https://repository.tudelft.nl/islandora/object/uuid%3A0cb03a83-148a-48b6-bb14-32a46fdb4e01_06/24/2020).
- Mersky, A.C., Sprei, F., Samaras, C., Qian, Z.S., 2016. Effectiveness of incentives on electric vehicle adoption in Norway. *Transport. Res. Transport Environ.* 46, 56–68.
- Noel, L., Carrone, A.P., Jensen, A.F., de Rubens, G.Z., Kester, J., Sovacool, B.K., 2019. Willingness to pay for electric vehicles and vehicle-to-grid applications: a Nordic choice experiment. *Energy Econ.* 78, 525–534.
- Norwegian Ministry of Transportation, 2017. National Transport Plan 2018–2029.
- Parsons, G.R., Hidrué, M.K., Kempton, W., Gardner, M.P., 2014. Willingness to pay for vehicle-to-grid (V2G) electric vehicles and their contract terms. *Energy Econ.* 42, 313–324.
- Plötz, P., Schneider, U., Globisch, J., Dütschke, E., 2014. Who will buy electric vehicles? Identifying early adopters in Germany. *Transport. Res. Pol. Pract.* 67, 96–109.
- Schmalfluss, F., Mair, C., Döbel, S., Kaempfe, B., Wuestemann, R., Krems, J.F., Keinath, A., 2015. User responses to a smart charging system in Germany: battery electric vehicle driver motivation, attitudes and acceptance. *Energy Res. Social Sci.* 9, 60–71.
- Sugiyama, M., 2012. Climate change mitigation and electrification. *Energy Pol.* 44, 464–468.
- van Heuveln, K., Ghotge, R., Annema, J.A., van Bergen, E., van Wee, B., Pesch, U., 2021. Factors influencing consumer acceptance of vehicle-to-grid by electric vehicle drivers in The Netherlands. *Travel Behaviour and Society* 24, 34–45.
- Wisniewski, J.W., 2015. *Microeconometrics in Business Management.* John Wiley & Sons.
- Yoo, S.H., Moon, H.S., 2006. An estimation of the future demand for portable Internet service in Korea. *Technol. Forecast. Soc. Change* 73 (5), 575–587.
- Zonneveld, J., 2019. Increasing Participation in V2G through Contract Elements: Examining the Preferences of Dutch EV Users Regarding V2G Contracts Using a Stated Choice Experiment. Master thesis. TU Delft, Delft, the Netherlands. url: <https://repository.tudelft.nl/islandora/object/uuid%3A3024ac31-b822-444b-a823-fe2951ad0ec7>.