

Received December 30, 2021, accepted February 2, 2022, date of publication February 9, 2022, date of current version February 22, 2022.

Digital Object Identifier 10.1109/ACCESS.2022.3150359

Co-Simulation of Optimal EVSE and Techno-Economic System Design Models for Electrified Fleets

NUH ERDOGAN¹, (Member, IEEE), **SADIK KUCUKSARI²**, (Member, IEEE),
AND UMIT CALI³, (Member, IEEE)

¹School of Engineering, Robert Gordon University, Aberdeen AB10 7GJ, U.K.

²Department of Applied Engineering and Technical Management, University of Northern Iowa, Cedar Falls, IA 50614, USA

³Department of Electric Power Engineering, Norwegian University of Science and Technology, 7034 Trondheim, Norway

Corresponding author: Umit Cali (umit.cali@ntnu.no)

This work was supported in part by the Sustainable Energy Authority of Ireland (SEAI) under the E-Fleet Project under Grant RDD527.

ABSTRACT As the transition to electric mobility is expanding at a rapid pace, operationally feasible and economically viable charging infrastructure is needed to support electrified fleets. This paper presents a co-simulation of optimal electric vehicle supply equipment (EVSE) and techno-economic system design models to investigate the behaviors of various EVSE configurations from cost and technical aspects. While the system design optimization is performed for a grid-tied PV system, the optimal EVSE model considers all EVSE options that are currently installed at workplaces. To investigate the impact of the EV utilization rate, three fleet sizes are considered, which are generated based on real EV fleet data. Furthermore, the impact of electricity rates is also explored through an innovative business EV-specific (BEV) rate and a conventional time-of-use (ToU) tariff. It is shown that investing in grid-tied renewable energy technologies for workplace charging infrastructure supply can lower charging costs. Cost savings differ from EVSE types and fleet size under the BEV rate, while EVSEs display similar cost-saving behavior under the ToU tariff irrespective of fleet size. DC Fast Charging (DCFC) EVSE is found to be highly sensitive to fleet size as compared to AC EVSEs. Moreover, DCFCs make better use of the BEV rate, which makes their economics competitive as much as AC EVSEs. Finally, it is found that the fleet size and AC EVSE types have a minor effect on the use of renewable energy in contrast to the DCFC case.

INDEX TERMS Electric vehicles, electric fleet, EVSE, optimization, PV, smart charging.

I. INTRODUCTION

There has been a trend towards transitioning to electrified fleets to meet zero-emissions mandates. Global companies have already shown interest and committed to accelerating the transition to electric mobility by shifting their conventional fleets to electric vehicles (EVs) [1]. For example, Walmart has announced to electrify the whole vehicle fleet by 2040. IKEA will provide zero-emission deliveries in all cities by 2025. The target of net-zero emissions logistics by 2050 from leading companies such as DHL Group, FedEx has already been set. Accordingly, the charging infrastructure, known as electric vehicle supply equipment (EVSE) at workplaces is gradually increasing. The number of global private

and public charging EVSE units has risen above 10 million in 2020 with a total charging capacity of 55 GW [1]. However, the lack of charging infrastructure and the demand charges in commercial and industrial rates associated with peak demand from charging loads are the most significant barriers to EV growth at workplaces. To overcome the demand charge barrier, some utilities have proposed EV-specific rates. This innovative approach bypasses the demand meter and requires installing a specific meter for charging station loads only [2]. While the idea is to shift charging loads towards periods of midday solar over-generation away from the peak, smart charging and scheduling are needed in order for the EV fleet owner to fully benefit from the rates in terms of cost savings [3].

Workplace EVSEs have been the primary focus to maintain EV fleet charging demand. Minimizing the cost of the

The associate editor coordinating the review of this manuscript and approving it for publication was Christopher H. T. Lee.

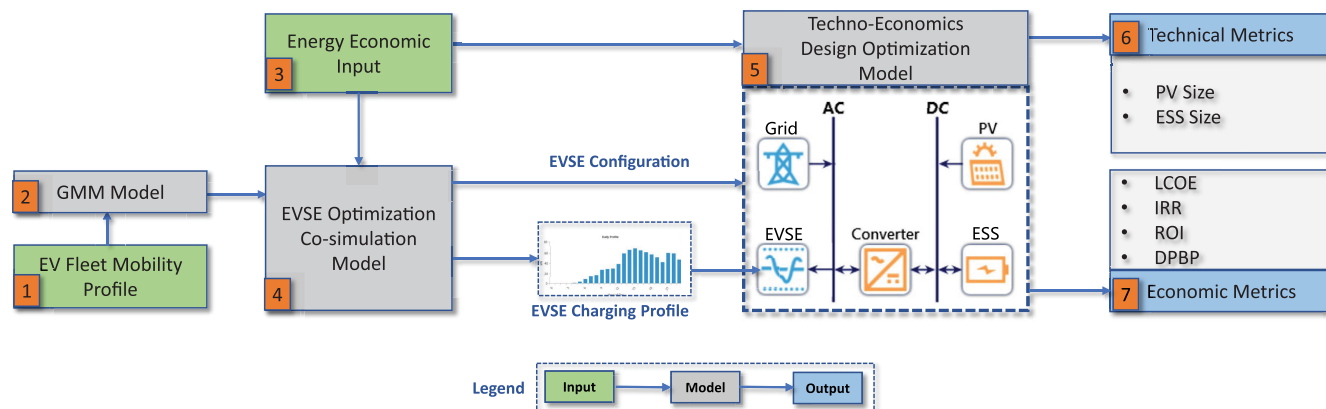

FIGURE 1. The proposed approach for co-simulation of optimal EVSE and techno-economic system design models.

deployment of EVSEs is, therefore, of primary interest to fleet owners [4]. Herein, the cost is described as the sum of three elements, i.e., operational charging cost, demand charge, and EVSE infrastructure cost including maintenance cost. Sizing the charging infrastructure has been done through optimal models [5]. Depending on EVSE types, the infrastructure cost differs greatly for fleet size. Therefore, most studies have focused on smart charging strategies in order not only to reduce operational charging costs, but also to use the charging infrastructure efficiently [6], [7]. It is shown that the smart charging algorithm can provide effective use of EVSEs in real-time with reduced charging costs. However, these studies did not consider the techno-economics of the EVSE over its lifecycle, which affects the daily levelized cost of charging. While these studies mostly considered a group of EVs (e.g., employees’ cars) at workplaces whose mobility can be better predicted, only a few studies used real fleet car data [8]–[11]. In [8], a model predictive charging control is proposed based on a schedule according to day-ahead market prices in which fleet EVs are clustered based on their state-of-charges (SOCs). Reference [9] presents a model for a public charging station with a battery swapping option serving an EV fleet. The cost and revenues are calculated in terms of the EVSE service provider and EV user. In [10], an optimization model is developed to schedule EVs with minimized charging costs, while scheduling conventional buses to minimize the operating costs and carbon emissions. Reference [11] presents an optimization model to minimize the total cost for the delivery route operational planning of an EV fleet. Since an EV fleet can be used to provide ancillary services to the power grid, an EV fleet optimization model is proposed to maximize the profit of an EV fleet in [12]. In [13], the economic value of an EV fleet from providing ancillary services is compared with those of an energy storage system through an optimal planning model. These studies consider homogeneous EVSEs while dealing with the cost figure. However, the impact of EVSE configurations on the cost figure has not been investigated.

Since the cost of electricity from some forms of renewables has reached grid parity, photovoltaic (PV) integrated charging

systems have been proposed to reduce costs and demand on the grid [14]–[17]. In [14], a grid-tied PV system for an EV charging station is designed to minimize the grid dependency. It is shown that incorporating storage into the system reduces the grid dependency by 25%. In [15], the cost of charging a group of EVs from PVs is minimized based on mixed-integer linear programming. Reference [16] proposes a charging scheduling in order to maximize the benefit of a charging station. Herein, the benefit is defined as the difference between the total solar energy use and energy imported from the grid. In [17], the cost of charging from a grid-tied PV system with energy storage is minimized based on a meta-heuristic optimization algorithm. These studies do not consider the cost of PV and storage systems while reducing the charging costs. However, the capital expenditures (CAPEX) of PV and storage systems can be a major part of the overall system CAPEX depending on the size and configuration of the charging station. Hence, the levelized cost of the charging figure can be greatly affected.

In order for the EV fleet transition to gain acceptance on a larger scale, it is necessary for companies to explore the opportunities and challenges associated with the operation of a fully electric fleet through optimal charging infrastructure design. The system design will produce a true levelized cost of charging for various EVSE configurations, assisting the fleet owner in making charging station design decisions. In this respect, this study deals with the techno-economic design optimization of workplace charging infrastructure to maintain a fully electric fleet at workplaces. The following research questions were developed in this study:

- Does the optimal charging infrastructure configuration differ from fleet size?
- What is the impact of EVSE configuration types on the levelized cost of charging an EV fleet with respect to fleet size?
- What is the impact of EVSE configuration types on renewable energy use in maintaining EV fleet charging demand?

TABLE 1. GMM components for EV fleet charging parameters.

Parameter	Component	$i = 1$	$i = 2$	$i = 3$	$i = 4$	$i = 5$
Charging energy need	ω_i	0.277	0.136	0.257	0.044	0.287
	μ_i [min]	6.97	21.70	16.74	26.90	12.41
	σ_i^2	8.302	32.956	24.531	23.934	15.907
Charge start time	ω_i	0.1813	0.1887	0.2595	0.3705	
	μ_i [min]	845.6	406.8	766.7	669.0	
	σ_i^2	2635	4753	270	27834	
EVSE Occupied time	ω_i	0.522	0.477			
	μ_i [min]	1160	198.66			
	σ_i^2	24546	17546			

- Does the behaviour of levelized cost of charging of EVSE configuration types differ from tariff structures and fleet size?

To investigate the above-mentioned research questions, this paper presents a co-simulation approach between EVSE and techno-economic system design optimization models (Fig. 1). The optimal EVSE model relies on a Gaussian Mixture Model (GMM) based on real EV fleet data. To minimize the overall cost of EVSE, a linear optimization model is developed and solved by implementing a heuristic charging algorithm. As such, the optimal sizes of EVSE configurations with associated optimal charging powers are determined and then fed into a techno-economic design optimization model. The latter uses a discounted cash flow analysis with project-specific assumptions about capital and operational expenditures, annual renewable energy yield, and financial structure. Finally, the levelized cost of charging an electric fleet under two ToU tariffs is calculated for various PV-based system design configurations and fleet sizes. A comprehensive comparative analysis is conducted to answer the research questions. The remainder of this paper is organized as follows: The EV fleet data and the modeling of their charging probability as GMM are presented in Section 2. Section 3 presents an optimal EVSE model which minimizes the daily levelized cost of EVSE at workplaces, while the techno-economic system model is described in Section 4. Simulation results are discussed in Section 5. Finally, Section 6 presents concluding remarks.

II. GAUSSIAN MIXTURE MODELLING OF EV FLEET CHARGING

The stochastic behavior of EV charging data can be modeled with a GMM. GMM is a parametric probability density function (PDF) representing weighted sum of N number of normal distributions (ND) [18]. GMM can provide smooth approximations for arbitrarily shaped densities such as the EV charging data. The approximation is achieved by using a discrete set of Gaussian functions, each is weighted with its own mean and variance [18]–[20]. A GMM can be defined as

$$f(x) = \sum_{i=1}^N \omega_i f_{ND(\mu_i, \sigma_i^2)}(x), \tag{1}$$

where, ω_i , μ_i , and σ_i^2 are the weight, mean, and variance of each normal distribution. The density function of each GMM

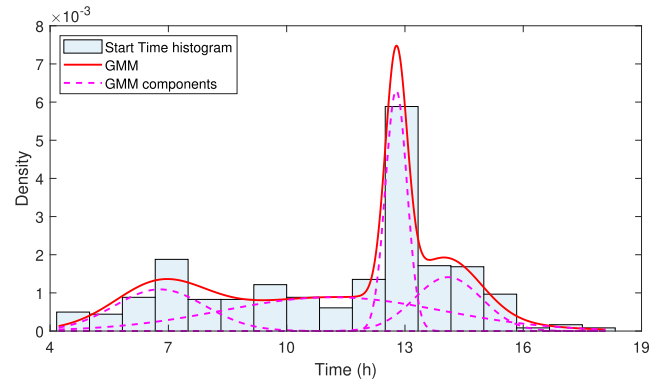

FIGURE 2. EV fleet charging charge start time histogram and its GMM fit.

component is a normal distribution defined as

$$f_{ND(\mu, \sigma^2)}(x) = \frac{1}{\sqrt{2\pi\sigma_i^2}} e^{-\frac{(x-\mu_i)^2}{2\sigma_i^2}}. \tag{2}$$

Since the integral of a PDF over a sample space is one, the sum of all the weights for each normal distribution needs to be equal to one. This results in the following constraint.

$$\sum_{i=1}^N \omega_i = 1, \tag{3}$$

subject to $\omega_i > 0$. In order to represent the data, the parameters ($\omega_i, \mu_i, \sigma_i^2$) need to be identified. As one of the methods, they are estimated from the original data based on an iterative algorithm called Expectation-Maximization (EM) which maximizes the log-likelihood expectation based on the desired number of GMM components [18], [19].

Matlab Statistics and Machine Learning Toolbox [21] is used to model Leeds Council EV fleet charging data set in [22]. The data set includes 724 charging events from July 25, 2020 to September 29, 2020 recorded from single-phase, L2/Mode-3 type EVSEs at 7.36 kW. The fleet consists of 339 EVs including various Renault Kangoo and Nissan EV models with 33 kWh battery capacity & 7.4 kW on-board charger ratings and 24/40 kWh battery capacities & 3.3/6.6 kW on-board charger, respectively. The data set includes charge start time, end time, total charging energy, and plug-in duration for each EV, while the EV information specific to charging event is not provided. It is assumed that all charging events occur in a day and no next day departure exist. The GMM model is developed for total charging energy per EV, $E_{required,i}$, charge start time, $t_{arr,i}$, and occupied time $t_{ocp,i}$. The number of components for each behavior is found through the Bayesian Information Criterion (BIC). The number of components with a minimum BIC value is selected from a wide range of component numbers. The parameters and number of components for each model calculated are reported in Table 1. The GMM of the charge start time has four PDFs with μ values of 845.6 (14h 5.4m), 406.8 (6h 46m), 766.7 (12h 46m), and 669 (11h 9 m). Fig. 2 shows the PDF plots of these four ND components and the GMM as

an example. The GMMs for the charging energy and occupied time are represented by four and two PDFs, respectively. The developed three models, i.e., charging energy, start and occupied times, are used to generate new fleet mobility data with 25, 100, and 300 EVs in order to study different fleet sizes. Then, the generated fleet mobility data is inputted into EVSE optimization co-simulation model, which is explained in the next section III.

III. EVSE COST OPTIMIZATION MODEL FOR EV FLEETS

The EVSE cost model from the authors' previous study in [2] is used to generate EV charging profiles and EVSE configurations to be used in the techno-economic design optimization model given in section IV. The model includes three cost elements, namely, daily charging energy cost, C_{op} , demand charge due to the contribution of EV charging to power demand, C_{dc} , daily leveled EVSE infrastructure cost, C_{LIC} , that embodies EVSE unit hardware (C_{unit}), installation, and maintenance (C_{ins}) costs. An annuity factor, AF , is considered with a discount rate of 5% for the time value of money for an accurate representation of the EVSE cost over its lifetime [5]. The cost model is formulated as a linear optimization problem to minimize the total cost of a charging station over its lifetime as follows [2]:

$$\min_{P_{ch,1} \dots P_{ch,n}, S_j} (C_{op} + C_{dc} + C_{LIC}), \quad (4)$$

with,

$$C_{op} = \sum_{s_j=1}^{s_j} \sum_{i=1}^n \sum_{t=1}^T \left(F(t) \times (P_{ch,i,s_j}(t) \cdot \frac{\Delta t}{60}) \right), \quad (5)$$

$$C_{dc} = C_{drate} \cdot (\max(\sum_{k=1}^{96} \sum_{t=1}^{15} \text{mean}(\sum_1^{s_j,n} P_{ch,i,s_j} \times ((k-1) \cdot 15 + t)))), \quad (6)$$

$$C_{LIC} = s_j \cdot AF \cdot (C_{unit} + C_{ins}), \quad (7)$$

subject to

$$\sum_{t=1}^T P_{ch,i}(t) \cdot \eta_i \cdot \frac{\Delta t}{60} = E_{required,i} \quad \forall t \notin [t_{arr,i}, t_{arr,i} + t_{ocp,i}], \quad (8)$$

$$\begin{cases} 0 \leq P_{ch,i}(t) \leq \min(\eta_i P_i^{rated}, \eta_J P_J^{rated}), & \forall J \in \{1, 2\} \\ 0 \leq P_{ch,i}(t) \leq \eta_J \cdot P_J^{rated}, & \forall J \in \{3, 4\} \end{cases} \quad (9)$$

$$\sum_{t=1}^T (P_{base}(t) + \sum_{s_j=1}^{s_j} \sum_{i=1}^n P_{ch,i,s_j}(t)) \leq P_{lim}, \quad (10)$$

where, $N = \{1, 2, \dots, n\}$ is set of EVs, $P_{ch,i} = \{P_{ch,i}(1) \dots P_{ch,i}(T)\}$ and $E_{required}$ are charging rates and energy of the i^{th} EV, respectively. C_{drate} is the demand charge rate per kW. T is number of time slots, $S = \{1, 2, \dots, s\}$ is number of charging units. $J = \{1, 2, 3, 4\}$ indicates the EVSE

types considered as follows: AC L1 and AC L2 are single and three-phase EVSEs at charging power rates of 7.4 and 22 kW, respectively. DCFC and DCFC dual-port are DC fast charging single and dual-port at a power rate of 50 kW charging power, respectively. $F = \{f(1) \dots f(T)\}$ is the daily energy cost in tariff considered which is given in detail below. P_i^{rated} and η_i are the on-board charger rated power and its efficiency of i^{th} EV, respectively. P_J^{rated} and η_J are the rated power and the efficiency of DCFC unit, respectively. P_{base} is the base load of a research institution considered as the workplace in this study. P_{lim} ensures that the total power demand of the workplace including the charging station load remains within the limit (500 kW) set in the tariff as a requirement for medium power customers.

A heuristic smart charging algorithm is developed for the efficient use of EVSE. The algorithm employs an uninterrupted charging profile [23] to address the practical considerations in which an EV is plugged in, start charging at an optimal time slot and remained to charge until gaining the desired SOC. It is assumed that EV is plug-off once the charging is completed and the subsequent EV is plugged in. The fleet EVs are scheduled based on their arrival times as a bidirectional charging event. The algorithm searches for the available time slot in an EVSE that can provide the required charging energy. If none of the existing EVSE units can serve incoming EVs between their arrival and departure times, a new EVSE unit is added. This ensures that the EVSE units are fully utilized. The flowchart of the charging algorithm is given in Fig. 3.

A. DESCRIPTION OF ToU AND EV SPECIFIC TARIFFS

In order to encourage and help businesses to electrify their fleets, EV specific rates are designed by several utilities [24]–[26]. EV specific energy monitoring requires a separate meter while maintaining the workplace energy meter. This helps to eliminate the demand charge for EV loads while keeping it in place for workplace demand. However, a separate monthly subscription fee per kW power block of EV load exists in this tariff structure. The tariff is designed such that the EV charging demand can be shifted towards off-peak hours or midday solar over-generation. In this study, general demand time-of-use (ToU) [27] and Business Electric Vehicle (BEV) [26] tariffs offered by the same utility company are scaled up by 1.6 to adapt for an Irish business premise as a case study. The tariffs considered, as well as the daily base load of the workplace are depicted in Fig. 4. As shown, the BEV has three different rates: 57.28 cents/kWh, 17.43 cents/kWh, and 21.35 cents/kWh at peak (4 PM-9PM), super off-peak (9AM-2PM), and off-peak times, respectively. The ToU has two rates: 34.60 cents/kWh in summer and 26.09 cents/kWh in winter at peak times (12PM - 6PM) and 30.08 cents/kWh in summer and 25.98 cents/kWh in winter at partial peak times. A regional tax rate of 13.5% is also included in the rates. These tariffs are used as the price vector F in Equation (5). The demand charge rate, C_{drate} , in ToU tariff is \$15.82 while

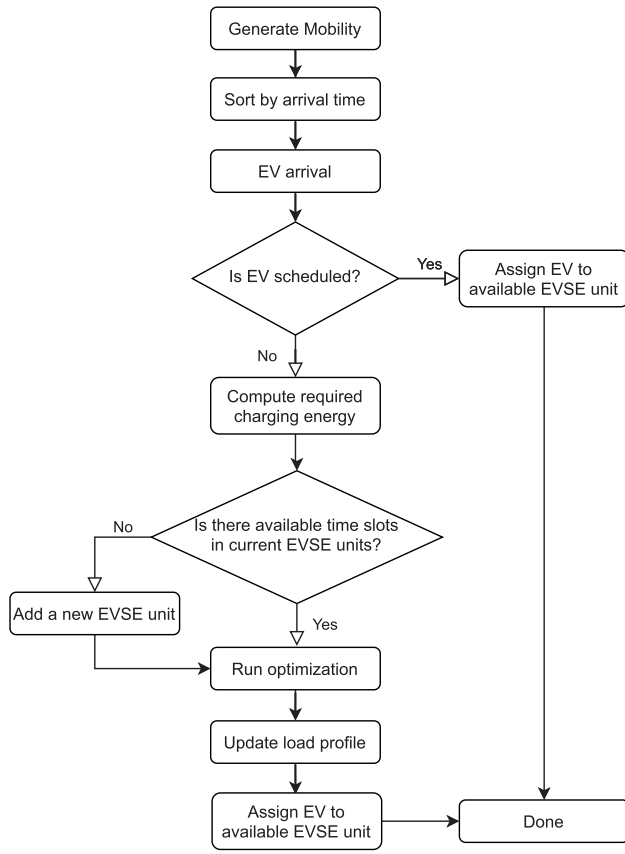

FIGURE 3. The flow chart of EVSE cost optimization model.

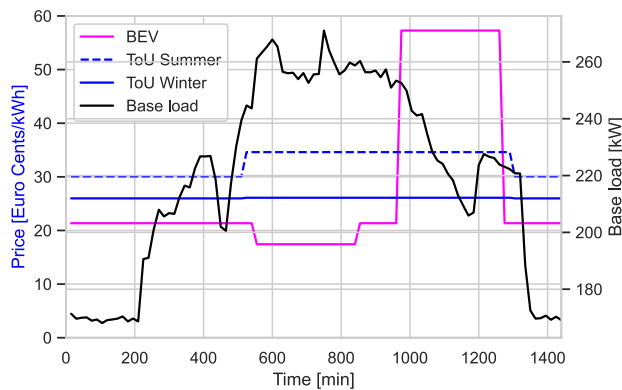

FIGURE 4. Workplace daily load profile along with ToU and EV specific tariffs considered.

the monthly subscription rate charge is \$160.92 per block of 50kW in the BEV tariff. Moreover, the P_{base} is not considered for the BEV tariff since it has a dedicated meter for the charging station only.

IV. TECHNO-ECONOMIC MODEL FOR GRID-TIED PV SYSTEM

This study proposes a grid-tied photovoltaic (PV) system to maintain the charging demand of the EV fleet. The system has the following components: (i) PV system, (ii) Lithium-ion battery as Energy Storage System (ESS), (iii) DC / AC

Converter, (iv) EVSE charging load. Since the system is designed to power the charging station only, the workplace charging load is not considered in the model. The techno-economic design optimization for the grid-tied PV system is performed using the HOMER Grid software package [28]. It provides a comprehensive techno-economic analysis of the investigated power system, meeting the electric load at the lowest value of Cost of Energy (CoE) and Net Present Cost (NPC) for various technology alternatives and resource availability. The major investment indicators such as CoE, NPC, Return on Investment (RoI), Internal rate of return (IRR), payback period which help make investment decisions, are calculated using the software.

The total NPC is calculated by [29]:

$$C_{NPC} = \frac{C_{ann,tot}}{C_{RF}}, \quad (11)$$

where, $C_{ann,tot}$ represents the cumulative annualized costs, i is the annual real discount or interest rate, and C_{RF} is the capital recovery factor.

CAPEX stands for Capital Expenditures and represents the total cost of all system components that are spent at the beginning of the project. The Euro currency is taken in the calculations. The CAPEX values for AC L1, AC L2 and DCFC is assumed to be 1,836 €, 6,000 €, and 58,000 €, respectively [30]. CAPEX values of the plate type PV and lithium-ion battery systems are assumed to be 1,097 €/kWh [31] and 1,100 €/kWh [32], respectively. A CAPEX value of 300€/kW is considered for the converter [28]. Furthermore, the lifespans of PV and converter are assumed to be 25 and 15 years, respectively. Moreover, the lifespan of EVSE types is assumed to be 15 years [33]. OPEX stands for Operational Expenditures and represents the system operation and maintenance costs that are recurring annually. 10 €/kw/year is the OPEX value which is used for the proposed models [34], [35]. $C_{tot,ann}$ is calculated by annualizing the CAPEX, OPEX and other relevant costs such as replacement costs. The C_{RF} is expressed by

$$C_{RF} = \frac{i(1+i)^N}{(1+i)^N - 1}, \quad (12)$$

where, N is the project lifespan which is assumed to be 25 years.

The CoE is a well-known energy economic metrics that indicates the average cost per kWh of useful electrical energy generated by the system. It can be expressed by

$$CoE = \frac{C_{ann,tot}}{E}, \quad (13)$$

where, E is the total annualized cost and energy consumption, respectively.

Renewable Fraction (RF) is a metric that indicates the percentage of total electrical energy supplied to the EVSE that comes from renewable energy resources. It is expressed by [28]

$$RF = 1 - \frac{E_{Grid}}{E_{RE}}, \quad (14)$$

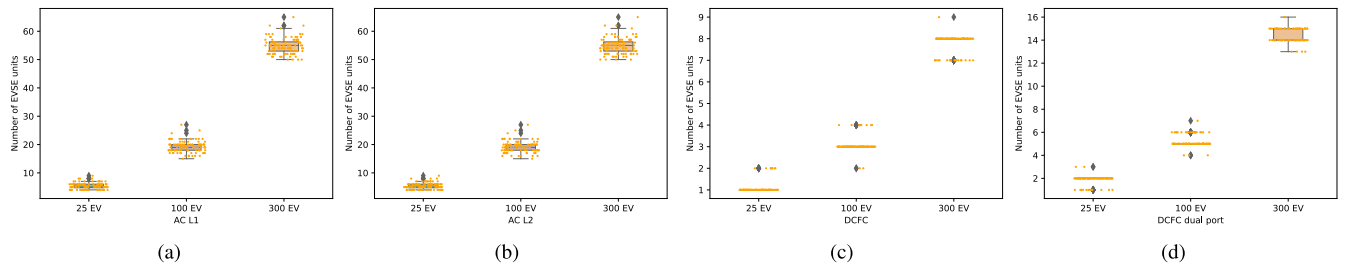

FIGURE 5. Distribution of optimal EVSE unit numbers for various EV fleet sizes: (a) AC L1, (b) AC L2, (c) DCFC, (d) DCFC dual port.

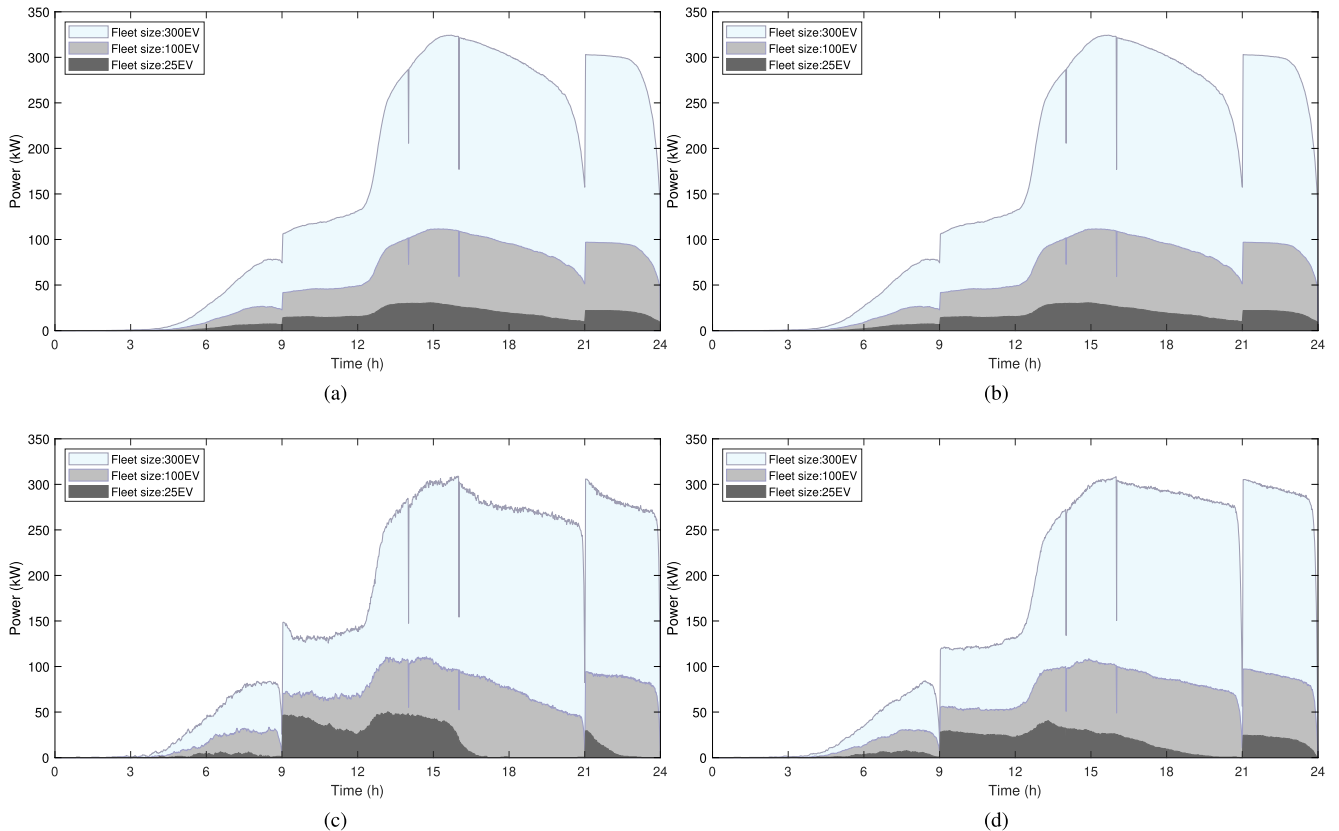

FIGURE 6. Total optimal charging demand of various EV fleet sizes under BEV tariff: (a) AC L1, (b) AC L2, (c) DCFC, (d) DCFC dual port.

where, E_{Grid} is the total amount of energy delivered from the grid to the EVSE and E_{RE} is the amount of energy generated by the PV system.

Return on Investment (RoI) is the economic metric that represents the rate of the annual cost savings or net income to the initial investment. It can be expressed by

$$ROI = \frac{\sum_{i=0}^{R_{proj}} C_{i,ref} - C_i}{N \cdot (C_{cap} - C_{cap,ref})}, \quad (15)$$

where, $C_{i,ref}$ is nominal annual cash flow for reference case system, C_i is nominal annual cash flow for current system, C_{cap} is capital cost of the current system and $C_{cap,ref}$ is capital cost of the reference system.

IRR as one of the most impactful economic metrics that represents the profitability of an investment plays a considerable role in making better economic decisions [36].

It refers to the discount rate, which makes the NPC of the project equal to zero. Payback Period is used to demonstrate how many years is needed to recover the invested amount from the specific project or investment. In order to consider the time value of money, Discounted Payback Period (DPBP) is used. DPBP is the payback where the discounted cash flow difference level exceeds zero.

V. SIMULATION RESULTS AND DISCUSSION

A. SIMULATION SETTINGS

Case studies consider three EV fleet sizes composed of 25, 100, and 300 EVs. The set of EVs is assumed to be 60% Nissan NV200 with 37 kWh battery and 6.6kW on-board charger and 40% Kangoo ZE Crew Van with 33kWh battery and 7.4 kW on-board charger. The workplace charging station is designed for four EVSE configurations, i.e., AC L1, AC L2, DCFC, and dual-port DCFC. The optimization models are

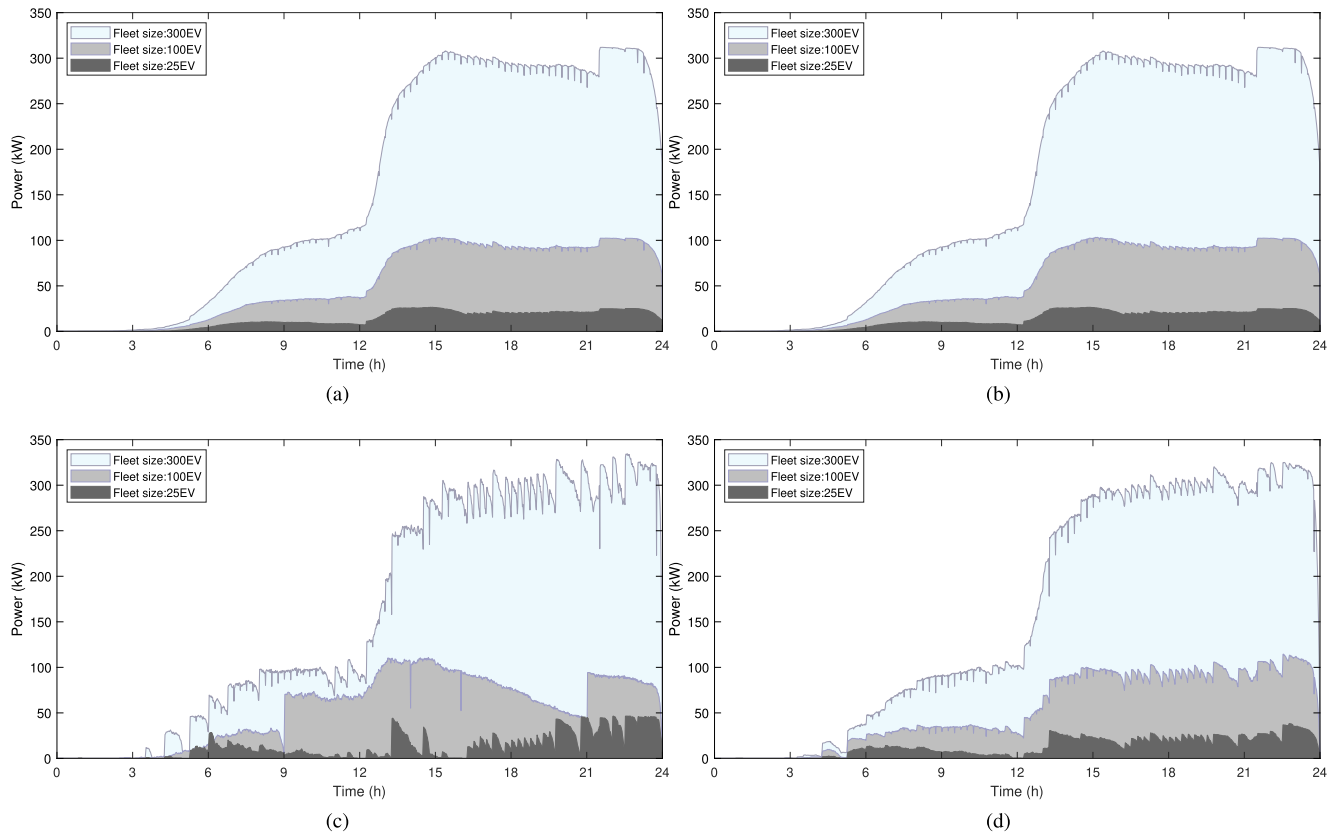

FIGURE 7. Total optimal charging demand of various EV fleet sizes under ToU tariff: (a) AC L1, (b) AC L2, (c) DCFC, (d) DCFC dual port.

solved by the smart charging algorithm using Matlab for the three fleets sizes under the ToU and BEV tariffs for each EVSE type considered. The models are run 100 times for each fleet size. Among 100 trials, the mean values of optimal EVSE numbers and EV charging powers are used to be fed into the techno-economic model.

Techno-economic simulations in HOMER have been performed for each case considered. The State-of-Charge (SoC) of the battery is assumed to be 20 %, whereas the efficiency of the converters is determined as 95 %. The controller is set to charge battery only from renewable energy resources. The other project-specific assumptions are as follows: an inflation rate of 2%, and a discounted rate of 8%.

B. EVSE OPTIMIZATION MODEL RESULTS

The distribution of optimal numbers of EVSEs with respect to EV fleet size is shown in Fig. 5. It is observed that in terms of the number of EVSE required, all EVSE types display the same behavior for the ToU and BEV tariffs. Approximately the same number of EVSEs are required for AC L1 and AC L2 types. While the charging capacity of AC L2 is much higher than that of AC L1, it is not efficiently used as the on-board charging ratings of the vehicles limit this capacity. As the fleet size increased, the number of EVs per EVSE remained almost the same for AC EVSE types, while it increased for both DCFC types considered. This confirms that in terms

of utilization rate, DCFC EVSE types perform better for the higher number of EVs.

The total optimal charging powers for EV fleets under TOU and BEV tariffs are shown in Figures 6 and 7, respectively. Higher charging rates with DCFC EVSEs make better use of the super-off peak times under the BEV rate. In this respect, both AC EVSE types display similar behaviors. Moreover, DCFCs result in less peak power for the fleet sizes of 100 EVs and 300 EVs, while AC EVSE gives less peak demand for the fleet of 25 EVs. As shown in Fig. 7, in the ToU tariff, the peak of total optimal charging demand from AC EVSE types is found to be always less than the demand from DCFCs for all fleet sizes. As compared to the BEV results, the peak of total charging demand under the ToU tariff is lower. This is because the demand charge does not exist in the BEV tariff. Minimizing the peak demand, therefore, is not sought in seeking the optimal solution. That results in higher peak demand irrespective of fleet size.

C. TECHNO-ECONOMIC SIMULATION RESULTS

System design optimization results for the EV fleet sizes under ToU and BEV tariffs are reported in Tables 2 and 3, respectively. Herein, tables provide optimized category winners among the techno-economically viable options. As the CAPEX of ESS is higher than that of PV, the system configuration returns with the lowest battery size under the category of grid-tied PV and ESS. It is obtained that the BEV

TABLE 2. Optimal sizes [kW] of system components for optimal EVSE configurations under TOU tariff.

EVSE Configuration	System Configuration	Fleet Size = 25 EV			Fleet Size = 100 EV			Fleet Size = 300 EV		
		PV	Converter	Battery	PV	Converter	Battery	PV	Converter	Battery
AC L1	Grid tied PV	67	40	-	275	163	-	833	500	-
	Grid tied PV + ESS	67	40	10	275	163	10	833	533	10
AC L2	Grid tied PV	68	42	-	275	167	-	825	525	-
	Grid tied PV + ESS	68	42	10	275	167	10	825	525	10
DCFC	Grid tied PV	62	38	-	288	175	-	813	488	-
	Grid tied PV + ESS	65	40	10	288	175	10	813	488	10
DCFC dual port	Grid tied PV	67	40	-	275	175	-	838	488	-
	Grid tied PV + ESS	67	42	10	275	175	10	838	488	10

TABLE 3. Optimal sizes [kW] of system components with respect to optimal EVSE configurations under BEV tariff.

EVSE Configuration	System Configuration	Fleet Size = 25 EV			Fleet Size = 100 EV			Fleet Size = 300 EV		
		PV	Converter	Battery	PV	Converter	Battery	PV	Converter	Battery
AC L1	Grid tied PV	74	49	-	306	198	-	917	600	-
	Grid tied PV + ESS	74	49	10	306	198	10	917	600	10
AC L2	Grid tied PV	75	48	-	306	198	-	933	600	-
	Grid tied PV + ESS	75	48	10	306	198	10	917	600	10
DCFC	Grid tied PV	75	50	-	309	202	-	925	613	-
	Grid tied PV + ESS	77	50	10	306	197	10	925	613	10
DCFC dual port	Grid tied PV	75	50	-	306	197	-	917	613	-
	Grid tied PV + ESS	74	50	10	306	197	10	917	613	10

TABLE 4. CoE figures [Euro Cents/kWh] of system configurations with respect to fleet size with ToU and EV specific tariffs.

EVSE Config.	System Configuration	Fleet Size = 25 EV		Fleet Size = 100 EV		Fleet Size = 300 EV	
		ToU	BEV	ToU	BEV	ToU	BEV
AC L1	Grid tied PV	24.3	13.6	23.1	13.0	22.7	12.6
	Grid tied PV + ESS	25.4	13.7	24.9	14.8	22.8	12.7
	Grid only	38.2	26.4	36.5	26.3	36.2	25.9
AC L2	Grid tied PV	26.4	15.8	24.9	14.8	24.4	13.7
	Grid tied PV + ESS	27.6	16.9	25.1	15.1	24.5	13.9
	Grid only	41.4	29.6	39.1	28.9	38.6	27.7
DCFC	Grid tied PV	35.5	24.9	27.5	17.6	25.6	15.4
	Grid tied PV + ESS	36.3	26.8	27.7	18.0	25.7	15.5
	Grid only	53.7	40.6	43.2	32.3	39.9	29.9
DCFC dual port	Grid tied PV	28.9	18.7	25.9	16.1	25.4	14.9
	Grid tied PV + ESS	30.1	20.1	26.3	16.4	25.5	15.0
	Grid only	44.9	32.7	40.9	30.5	39.9	29.3

tariff results in higher PV sizes as compared to the ToU tariff. In this respect, EVSE types demonstrate similar behaviors. The rate of charging demand per unit of PV power remains almost the same irrespective of EVSE type.

The CoE figures calculated for the system configurations in Tables 2 and 3 are summarized in Table 4. The PV configurations are found to have the best economics of all EVSE configurations. In this case, the CoE under the ToU tariff is reduced by approximately 35% irrespective of EVSE types. AC L1 and L2 display lower CoE figures between 22.7-24.3 Cents/kWh and 22.8-25.4 Cents/kWh, respectively. The CoE slightly decreases as the number of EVs in the fleet increases. While L1 and L2 EVSEs display similar technical characteristics, the CoE for AC L2 is higher since the CAPEX value is increased by 2-fold as compared to that of L1. DCFC is found to have the highest CoE figure of 25.6-35.5 Cents/kWh depending on the EV fleet size. However, the CoE with respect to the grid import case is still reduced by one-third. In the case of the BEV tariff, CoE is further reduced. In this case, the CoE with respect to the grid supply is reduced by approximately 50% and 45% for

TABLE 5. The % share of renewable energy over total charging load consumption from optimal EVSE configurations.

EVSE Config.	System Configuration	Fleet Size = 25 EV		Fleet Size = 100 EV		Fleet Size = 300 EV	
		ToU	BEV	ToU	BEV	ToU	BEV
AC L1	Grid tied PV	50.7	56.2	50.1	54.5	50.1	53.8
	Grid tied PV + ESS	51.3	56.3	50.2	54.8	50.1	53.9
AC L2	Grid tied PV	51.2	56.6	50.2	54.5	50.1	54.3
	Grid tied PV + ESS	51.9	57.3	50.4	54.8	50.1	53.9
DCFC	Grid tied PV	44.6	60	53.9	56.5	48.9	54.4
	Grid tied PV + ESS	46.8	62.4	54.1	56.4	48.9	54.5
DCFC dual port	Grid tied PV	48.7	59.2	50.1	55.1	49.7	53.8
	Grid tied PV + ESS	49.6	59.7	50.2	55.3	49.8	53.8

AC and DCFC EVSE types, respectively. As the fleet size increases, the CoE for DCFC reduces more than that of AC EVSEs. It can be concluded that DCFC is more sensitive to EV utilization rate. Moreover, DCFCs make better use of the BEV tariff.

The renewable energy use of EV fleets with respect to EVSE types are calculated as in Table 5. The renewable energy fraction under the ToU tariff is at the level of 45-50% depending on the EVSE type. The BEV tariff further increases the share of renewable energy up to 62.4%. In this respect, charging demand (e.g., fleet size) has a minor effect on the use of renewable energy sources. However, EVSE types might affect the use of renewable energy.

The economic metrics calculated for the optimal system configurations with the ToU and BEV tariffs are presented in Table 6 and 7, respectively. It is found that AC EVSE types have a minor effect on the system economics irrespective of fleet size. In this case, the system's economics are highly affected by its own configurations since the rate of AC EVSE's CAPEX to total CAPEX is very low. The DPBP is found to be approximately 7.7 years. However, the system economics is more affected in DCFC types with respect to fleet size, ranging from 7.2-9.3 years. This is due to the higher infrastructure costs required for DCFCs. Similar economics

TABLE 6. Economics of optimal system configurations with respect to EVSE configurations under TOU tariff.

EVSE Config.	System Configuration	Fleet Size = 25 EV			Fleet Size = 100 EV			Fleet Size = 300 EV		
		RoI (%)	IRR (%)	DBPB(Yr)	RoI (%)	IRR (%)	DBPB(Yr)	RoI (%)	IRR (%)	DBPB(Yr)
AC L1	Grid tied PV	8.6	12	7.7	8.4	11.7	7.8	8.2	11.5	7.9
	Grid tied PV + ESS	7.3	10.5	8.2	8	11.3	7.9	8.1	11.3	8
AC L2	Grid tied PV	8.5	11.9	7.7	8.4	11.7	7.8	8.2	11.5	7.9
	Grid tied PV + ESS	7.2	10.4	8.3	8	11.3	7.9	8.1	11.4	8.0
DCFC	Grid tied PV	6.3	9.3	9.3	9.5	12.9	7.2	8.1	11.3	8.0
	Grid tied PV + ESS	4.8	7.4	11.1	9.2	12.7	7.3	8	11.2	8.1
DCFC dual port	Grid tied PV	7.4	10.5	8.5	8.1	11.3	8	8	11.3	8.1
	Grid tied PV + ESS	6.1	9	9	7.8	11	8.3	7.9	11.1	8.2

TABLE 7. Economics of optimal system configurations with respect to EVSE configurations under BEV tariff.

EVSE Config.	System Configuration	Fleet Size = 25 EV			Fleet Size = 100 EV			Fleet Size = 300 EV		
		RoI (%)	IRR (%)	DBPB(Yr)	RoI (%)	IRR (%)	DBPB(Yr)	RoI (%)	IRR (%)	DBPB(Yr)
AC L1	Grid tied PV	10.3	13.8	6.8	10.3	13.9	6.8	10.3	13.9	6.8
	Grid tied PV + ESS	10.1	13.7	6.9	9.8	13.4	7	10.2	13.7	6.8
AC L2	Grid tied PV	10.2	13.8	6.8	10.3	13.9	6.8	10.2	13.8	6.8
	Grid tied PV + ESS	8.6	12	7.5	9.8	13.4	7	10.2	13.7	6.8
DCFC	Grid tied PV	10.2	13.7	6.8	10.2	13.8	6.8	10.2	13.8	6.8
	Grid tied PV + ESS	8	11.4	7.6	9.8	13.4	7	10.1	13.6	6.9
DCFC dual port	Grid tied PV	10.2	13.8	6.8	10.3	13.9	6.8	10.3	13.8	6.8
	Grid tied PV + ESS	8.6	12.1	7.4	9.8	13.4	7	10.1	13.6	6.9

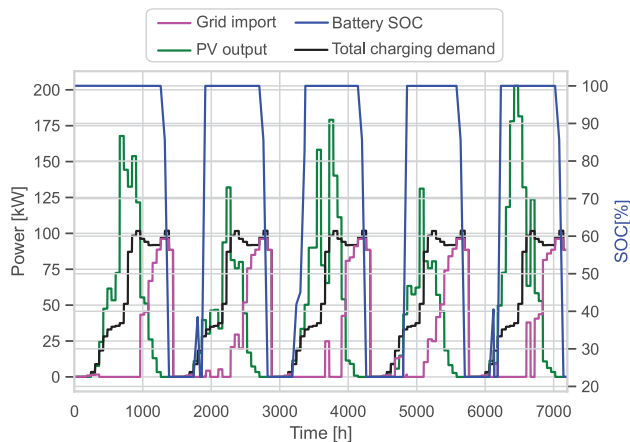

FIGURE 8. Generation and total charging demand profiles of each system components serving the fleet of 100 EVs for a week.

are obtained for AC EVSEs with the BEV rate. In this case, DCFCs’ economics have improved since DCFCs make better use of renewables under the BEV rate. As a result, DCFC investment, irrespective of fleet size has the same economics as in the AC EVSEs.

In terms of IRR performance, the scenarios for the TOU tariff are investigated in Table 6. The grid-tied PV + ESS system with DCFC configuration has the lowest IRR value of 7.4% for the smallest fleet size, while the grid-tied PV system with DCFC configuration has the highest IRR value of 12.9% for the 100 EV simulations. Similar investigations are performed for the BEV tariff. The best IRR figure of 13.9 % is found for the grid-tied PV system with all EVSE configurations for a fleet size of 100 EVs. In terms of IRR and RoI, the grid-tied PV system has slightly better results as compared to the ESS option. As the number of EVs increases,

IRR and other energy economic metrics converge to yield more saturated results for various scenarios. Similarly, the scenarios with the BEV tariff seem to be more stable in terms of deviations in IRR and RoI performance, if one considers all possible EVSE configurations. Time-domain analysis of optimal system operation for AC EVSE is shown in Fig. 8. Note that fleet EVs are assumed to be charged on weekdays. Thus, this figure shows the generation and total charging demand profiles over a week. Here, the controller is set to charge the battery only from renewable energy and set a lower SOC limit of 20%. The PV system’s capacity factor and annual hours of operation are found to be 10.6% and 4,378. As the fleet size increases, the annual throughput of the Li-ion battery also increases. It is observed that the ToU tariff makes higher use of batteries as compared to the BEV tariff. The use of batteries from DCFCs ranges from 2,373 kWh to 3,563 kWh while the annual throughput for AC EVSE configuration varies from 1,988 kWh to 3,580 kWh. As such, the expected life is found to be approximately between 8-11.5 years.

VI. CONCLUSION

Techno-economic system design optimization has been performed for a workplace charging station to maintain an EV fleet charging demand. The impact of various EVSE configurations on the cost of charging energy and renewable energy use has been investigated for various EV utilization rates (e.g., fleet sizes) through a proposed co-simulation of optimal EVSE and system design models. The impact of innovative EV specific rates has also been evaluated. The following can be concluded from the analysis

- The PV configuration under the ToU and BEV tariffs provides cost savings with respect to the grid supplying case by approximately 35% and 45-50%, respectively.

- For the fleet sizes considered, AC L1 is found to have the best economics, while DCFC might be competitive for large EV fleet sizes under the BEV tariff.
- AC EVSE configurations have a minor effect on the economics of the system irrespective of fleet size, while it is significantly affected by DCFCs with respect to fleet size. In this respect, DCFCs are highly sensitive to the EV utilization rate as compared to AC EVSE types.
- In terms of renewable energy use, the BEV tariff is superior. The fleet size and AC EVSE types have a minor effect on the use of renewable energy while DCFCs might affect it.
- Thanks to higher charging powers, DCFCs make better use of the BEV tariff. As a result, their investments operating under the BEV tariff are becoming as profitable as AC EVSEs.

REFERENCES

- [1] (2021) *Global EV Outlook: Accelerating Ambitions Despite the Pandemic*. Accessed: Dec. 1, 2021. [Online]. Available: <https://www.iea.org/reports/global-ev-outlook-2021>
- [2] S. Kucuksari and N. Erdogan, "EV specific time-of-use rates analysis for workplace charging," in *Proc. IEEE Transp. Electrific. Conf. Expo (ITEC)*, Jun. 2021, pp. 783–788.
- [3] S. Powell, E. C. Kara, R. Sevlian, G. V. Cezar, S. Kiliccote, and R. Rajagopal, "Controlled workplace charging of electric vehicles: The impact of rate schedules on transformer aging," *Appl. Energy*, vol. 276, May 2020, Art. no. 115352.
- [4] N. Erdogan, D. Pamucar, S. Kucuksari, and M. Deveci, "An integrated multi-objective optimization and multi-criteria decision-making model for optimal planning of workplace charging stations," *Appl. Energy*, vol. 304, Jul. 2021, Art. no. 117866.
- [5] Y. Huang and Y. Zhou, "An optimization framework for workplace charging strategies," *Transp. Res. C, Emerg. Technol.*, vol. 52, pp. 144–155, Mar. 2015.
- [6] O. Frendo, N. Gaertner, and H. Stuckenschmidt, "Real-time smart charging based on precomputed schedules," *IEEE Trans. Smart Grid*, vol. 10, no. 6, pp. 6921–6932, Nov. 2019.
- [7] O. Frendo, J. Graf, N. Gaertner, and H. Stuckenschmidt, "Data-driven smart charging for heterogeneous electric vehicle fleets," *Energy AI*, vol. 1, Aug. 2020, Art. no. 100007.
- [8] K. Šepetanc and H. Pandžić, "A cluster-based model for charging a single-depot fleet of electric vehicles," *IEEE Trans. Smart Grid*, vol. 12, no. 4, pp. 3339–3352, Mar. 2021.
- [9] T. Zhang, X. Chen, B. Wu, M. Dedeoglu, J. Zhang, and L. Trajkovic, "Stochastic modeling and analysis of public electric vehicle fleet charging station operations," *IEEE Trans. Intell. Transp. Syst.*, early access, Aug. 4, 2021, doi: 10.1109/TITS.2021.3099825.
- [10] G.-J. Zhou, D.-F. Xie, X.-M. Zhao, and C. Lu, "Collaborative optimization of vehicle and charging scheduling for a bus fleet mixed with electric and traditional buses," *IEEE Access*, vol. 8, pp. 8056–8072, 2020.
- [11] P. Diaz-Cachinero, J. I. Munoz-Hernandez, J. Contreras, and G. Munoz-Delgado, "An enhanced delivery route operational planning model for electric vehicles," *IEEE Access*, vol. 8, pp. 141762–141776, 2020.
- [12] A. A. Al-obaidi and H. E. Z. Farag, "Adaptive optimal management of EV battery distributed energy for concurrent services to transportation and power grid in a fleet system under dynamic service pricing," *IEEE Trans. Ind. Informat.*, vol. 18, no. 3, pp. 1618–1628, Mar. 2022.
- [13] A. Aldik, A. T. Al-Awami, E. Sortomme, A. M. Muqbel, and M. Shahidehpour, "A planning model for electric vehicle aggregators providing ancillary services," *IEEE Access*, vol. 6, pp. 70685–70697, 2018.
- [14] G. R. C. Mouli, P. Bauer, and M. Zeman, "System design for a solar powered electric vehicle charging station for workplaces," *Appl. Energy*, vol. 168, pp. 434–443, Apr. 2016.
- [15] G. R. Chandra Mouli, M. Kefayati, R. Baldick, and P. Bauer, "Integrated PV charging of EV fleet based on energy prices, V2G, and offer of reserves," *IEEE Trans. Smart Grid*, vol. 10, no. 2, pp. 1313–1325, Mar. 2019.
- [16] Y. Zhang and L. Cai, "Dynamic charging scheduling for EV parking lots with photovoltaic power system," *IEEE Access*, vol. 6, pp. 56995–57005, 2018.
- [17] W. Jiang and Y. Zhen, "A real-time ev charging scheduling for parking lots with pv system and energy store system," *IEEE Access*, vol. 7, pp. 86184–86193, 2019.
- [18] D. Reynolds, *Gaussian Mixture Models*. Boston, MA, USA: Springer, 2009, pp. 659–663.
- [19] R. Singh, B. C. Pal, and R. A. Jabr, "Statistical representation of distribution system loads using Gaussian mixture model," *IEEE Trans. Power Syst.*, vol. 25, no. 1, pp. 29–37, Feb. 2010.
- [20] J. Quirós-Tortós, A. Navarro-Espinoza, L. F. Ochoa, and T. Butler, "Statistical representation of ev charging: Real data analysis and applications," in *Proc. Power Syst. Comput. Conf. (PSCC)*, 2018, pp. 1–7.
- [21] MATLAB, (R2021b). *Statistics and Machine Learning Toolbox*. Accessed: Feb. 15, 2022. [Online]. Available: <https://www.mathworks.com/products/statistics.html>
- [22] L. C. Council. (Sep. 29, 2020). *Ev Fleet Chargepoint Use*. [Online]. Available: <https://data.gov.U.K./dataset/2279b730-bf4e-40c4-b2de-c82d43ae16d2/ev-fleet-chargepoint-use>
- [23] A. Malhotra, N. Erdogan, G. Binetti, I. D. Schizas, and A. Davoudi, "Impact of charging interruptions in coordinated electric vehicle charging," in *Proc. IEEE Global Conf. Signal Inf. Process. (GlobalSIP)*, Dec. 2016, pp. 901–905.
- [24] Electric. (2020) *Electric Vehicle Pricing Plans*. [Online]. Available: <https://www.sdge.com/residential/pricing-plans/about-our-pricing-plans/electric-vehicle-plans>
- [25] S. C. Edison. (Mar. 1, 2019). *Electric Vehicle Rates for Businesses*. [Online]. Available: <https://www.sce.com/business/rates/electric-car-business-rates/business/rates/electric-car-business-rates>
- [26] P. Gas. (May 1, 2020). *Electric Schedule BEV Business Electric Vehicle*. [Online]. Available: https://www.pge.com/en_US/small-medium-business/energy-alternatives/clean-vehicles/ev-charge-network/electric-vehicle-rate-plans.page
- [27] (Jul. 8, 2021). *Medium General Demand-Metered Service*. [Online]. Available: <https://www.pge.com/tariffs/index.page>
- [28] UL. (Dec. 26, 2021). *Homer Grid Distributed Generation*. [Online]. Available: <https://www.homerenergy.com/products/grid/index.html>
- [29] P. Gilman, T. Lambert, and P. Lilienthal. *Chapter 15: Micropower System Modeling With Homer*. Accessed: Feb. 15, 2022. [Online]. Available: <https://www.osti.gov/biblio/1461763>
- [30] B. Borlaug, S. Salisbury, M. Gerdes, and M. Muratori, "Levelized cost of charging electric vehicles in the united states," *Joule*, vol. 4, no. 7, pp. 1470–1485, Jul. 2020.
- [31] U. Halden, U. Cali, M. F. Dyngne, J. Stekli, and L. Bai, "DLT-based equity crowdfunding on the techno-economic feasibility of solar energy investments," *Sol. Energy*, vol. 227, pp. 137–150, Oct. 2021.
- [32] J. Figgenger, P. Stenzel, K.-P. Kairies, J. LinBen, D. Haberschusz, O. Wessels, M. Robinius, D. Stolten, and D. U. Sauer, "The development of stationary battery storage systems in Germany—status 2020," *J. Energy Storage*, vol. 33, Jan. 2021, Art. no. 101982.
- [33] E. Ucer, I. Koyuncu, M. C. Kisacikoglu, M. Yavuz, A. Meintz, and C. Rames, "Modeling and analysis of a fast charging station and evaluation of service quality for electric vehicles," *IEEE Trans. Transport. Electrific.*, vol. 5, no. 1, pp. 215–225, Mar. 2019.
- [34] E. Vartiainen, G. Masson, C. Breyer, D. Moser, and E. R. Medina, "Impact of weighted average cost of capital, capital expenditure, and other parameters on future utility-scale PV levelised cost of electricity," *Prog. Photovolt., Res. Appl.*, vol. 28, no. 6, pp. 439–453, Jun. 2020.
- [35] U. Cali, U. Halden, M. F. Dyngne, and A.-S. Bukvic-Schaefer, "Blockchain-enabled equity crowdfunding for energy storage investments," in *Proc. Int. Conf. Smart Energy Syst. Technol. (SEST)*, Sep. 2021, pp. 1–6.
- [36] U. Cali, N. Erdogan, S. Kucuksari, and M. Argin, "Techno-economic analysis of high potential offshore wind farm locations in Turkey," *Energy Strategy Rev.*, vol. 22, pp. 325–336, 2018.

• • •