

Distributed energy resource participation in electricity markets: A review of approaches, modeling, and enabling information and communication technologies

Joseph Stekli^{a,b}, Linquan Bai^b, Umit Cali^{c,*}, Ugur Halden^c, Marthe Fogstad Dyrge^c

^a Electric Power Research Institute, 1300 W. WT Harris Blvd., Charlotte, 28262, NC, USA

^b University of North Carolina at Charlotte, 9201 University City Blvd., Charlotte, 28223, NC, USA

^c Norwegian University of Science and Technology, O. S. Bragstads plass 2E, 7034, Trondheim, Norway

ARTICLE INFO

Keywords:

distributed energy resources (DER)
local energy market
aggregated DER
distribution system operator
distributed ledger technology

ABSTRACT

The continued development of distributed energy resources (DER), information and communications technologies is enabling a greater number of parties to participate in electricity markets. This review explores the various methods that DERs may utilize to participate in electricity markets, the differing architectures and methodologies used to model their participation, the past and future development of communications technologies that has enabled this participation, and examples of commercial implementations of solutions to DER participation in electricity markets.

1. Introduction

It is difficult to pinpoint when the term distributed energy resources (DERs) first entered the lexicon. Many cite the Public Utility Regulatory Policies Act (PURPA) of 1978 as the pivotal piece of legislation that distinguished smaller, more locally sited and customer owned electricity generation resources from more centrally located, utility-owned electricity generation resources [1]. However, this legislation never uses the term DER and only specified that it applied to “small” electricity generation sources, which the Federal Energy Regulatory Commission (FERC) subsequently defined as those less than 80 MW in size [2], much larger than the 10 MW that most define as the size limit for DER today [3].

While size is one component of defining a DER, there is also a technology dimension to what constitutes DER. The original motivation for the PURPA legislation was largely a response to the oil crisis of the 1970s, with a focus on reducing energy usage and reducing consumer energy costs [1]. Given the state of technology at the time, this largely limited commercial, grid connected DERs to smaller versions of fossil fired thermal units. However, over the subsequent decades improvement in new energy technologies such as solar photovoltaics (PV), wind, and lithium ion (Li-ion) batteries has allowed the selection of DER technology options to broaden. The National Association of Regulatory

Utility Commissioners (NARUC) recently provided the following definition for DER:

A DER is a resource sited close to customers that can provide all or some of their immediate power needs and can also be used by the system to either reduce demand (such as energy efficiency) or increase supply to satisfy the energy or ancillary service needs of the distribution grid. The resources, if providing electricity or thermal energy, are small in scale, connected to the distribution system, and close to load. Examples of different types of DER include photovoltaic solar, wind, and combined heat and power (CHP), energy storage demand response, electric vehicles, microgrids, and energy efficiency.” [3]

Size and technology largely complete the definition of DER, but there is a final consideration of note when considering DER operation and economics. Specifically, this is whether the DER is connected in-front-of-meter (IFM) or behind-the-meter (BTM). Broadly, IFM installations are larger and treated, both in modeling and in practice, as similar to central generation assets as they are generally large enough to directly participate in wholesale electricity markets. BTM installations, on the other hand, are typically located at a residence or a commercial building, are smaller in size, and are not capable of direct participation in wholesale electricity markets by themselves (for reasons discussed below).

With increasing government support for and cost competitiveness of

* Corresponding author.

E-mail addresses: jstekli@epri.com (J. Stekli), linquanbai@unc.edu (L. Bai), umit.cali@ntnu.no (U. Cali), ugur.halden@ntnu.no (U. Halden), marthe.f.dyrge@ntnu.no (M.F. Dyrge).

<https://doi.org/10.1016/j.esr.2022.100940>

Received 24 January 2022; Received in revised form 2 July 2022; Accepted 16 August 2022

Available online 26 August 2022

2211-467X/© 2022 The Authors. Published by Elsevier Ltd. This is an open access article under the CC BY license (<http://creativecommons.org/licenses/by/4.0/>).

List of abbreviations

AC	Alternating Current	LBNL	Lawrence Berkeley National Laboratory
ARIMA	Auto Regressive Integrated Moving Average	Li-ion	Lithium-ion
BTM	Behind-the-Meter	LMP	Locational Marginal Price
CAISO	California Independent System Operator	MCP	Mix Complementary Problem
CHP	Combined Heat and Power	MILP	Mixed Integer Linear Program
DC	Direct Current	MISO	Mid-Continent System Operator
DER	Distributed Energy Resource	MPEC	Mathematical Program with Equilibrium Constraints
DLMP	Distributed Locational Marginal Price,	MW	Megawatt
DLT	Distribution Ledger Technology	NARUC	National Association of Regulatory Utility Commissioners
DR	Demand Response	NERC	North American Electric Reliability Corporation
DSO	Distribution System Operator	NIST	National Institute of Standards and Technology
ERCOT	Electric Reliability Council of Texas	NLP	Non-linear Programming
EV	Electric Vehicle	NYISO	New York Independent System Operator
FERC	Federal Energy Regulatory Commission	OPF	Optimized Power Flow
GS	Grid Services	OSI	Open Systems Interconnection
ICE	Intercontinental Exchange	OTC	Over the Counter
IEEE	Institute of Electrical and Electronics Engineers	PURPA	Public Utility Regulatory Policies Act
IFM	In-Front-of-Meter	PV	Photovoltaics
ISO	Independent System Operator	RTO	Retail Transmission Operator
ISO-NE	Independent System Operator – New England	SPP	Southeast Power Pool
LAN	Local Area Network	TE	Transactive Energy
		VCG	Vickrey-Clarke-Groves
		VPP	Virtual Power Plant

the technologies highlighted in the NARUC definition of DER, along with increasing demand for clean energy technologies, the growth of DER deployment has rapidly increased over the past decade, a trend that is expected to continue over the foreseeable future [4]. With this growth has come interest in how BTM DER systems might participate in electricity markets. Generally, two approaches for BTM DER participation in electricity markets have been proposed: aggregation of DERs to meet size requirements that allow them to participate in wholesale electricity markets or the creation of distribution system markets, operated by distribution system operators (DSOs), in which individual BTM DER systems can participate. Each of these approaches represent a technically viable way to integrated BTM DER systems into market participation. To this point, there is a gap in the literature for a review that holistically captures the differing methodologies that can be implemented to model the economic impacts of these approaches, the communication technologies that are either required for or help to improve their operation, and the current commercial activity utilizing these approaches. This paper seeks to fill that gap.

The remainder of this paper consists of a review of the economic modeling mechanisms, methods, and architectures for BTM DER participation in each of these methodologies, along with how new information and communication technologies are enabling this participation and examples of the implementation and deployment of these approaches. This paper will generally discuss market rules and mechanisms in the context of U.S. rules and regulations, though many of these rules and regulations are similar to those found in other countries. Additionally, it should be noted that political considerations ultimately will play a critical role in the development, or lack of development, of DER participation in wholesale markets. The political considerations are multi-faceted, likely concern local, state, and federal governments, and a discussion of the variations in ways that the politics could go are worthy of a standalone review, which is why they are considered out of scope for this effort. Section 2 discusses BTM DER participation in wholesale electricity markets, Section 3 discusses distributed electricity markets operated by DSOs that would allow BTM DER participation in these newly created markets and Section 4 provides a conclusion for this review.

2. DERS in wholesale electricity markets

2.1. Background

It may not be readily clear to many why DER systems owned by separate parties would be aggregated together. This section will provide the motivation for why aggregation has been necessary and provides a history of efforts in DER aggregation. In order to participate in most independent system operator (ISO) or retail transmission operator (RTO) markets, generators must meet a minimum size threshold. This historically has been on the order of 500 kW – 1 MW, though the recent FERC Order 2222 requires that all U.S. ISO/RTOs set this limit at 100 kW [5]. IFM DERs have generally met either of these size thresholds, allowing their direct participation in these markets. Most BTM DERs have not historically met this threshold and many still do not meet the new threshold established by Order 2222, including the majority of residential installations. This inability of BTM DERs to participate in electricity markets has been cited as a factor that has held back DER deployment while also failing to allow ISO/RTOs to realize the benefits that BTM DERs can provide to the bulk power system (see Table 1) [6].

Aggregation of assets allows these size thresholds to be met by BTM DERs, thereby allowing them to participate in wholesale markets. Asset aggregation can have two separate meanings in the energy space. The first is aggregation of assets that constitute a meaningful amount of energy load to provide demand response (DR) [25]. The second is the aggregation of energy generation or storage assets, commonly known as DER aggregation, to provide energy and/or grid services (GS), the latter of which is also often referred to as ancillary services. DR aggregation has, thus far, generally been provided by utilities while DER aggregation is generally provided by a third party responsible for the aggregation of the assets, owned by a number of differing parties, to dispatch them in a way that meets the rules of the ISO/RTO or utility responsible for operations of the power grid [26].

While DR differs from the NARUC definition of DER given above, the aggregation of assets to provide DR for participation into electricity markets is similar in concept to DER aggregation and has a longer history to draw examples from. Further, many academic studies look at aggregation of DR and DER together. Historically, DR has generally been a utility led program (though that is changing more recently) that allows

Table 1
Potential benefits of DR/DER aggregation to the bulk power system.

Benefit	Description	References
Grid Services	The provision of services needed for the reliable operation of the power grid. Examples include frequency regulation, spinning and non-spinning reserves, and black start, among others.	[7–14]
Dispatchable Generation	The ability to produce power when needed (as defined by an entity such as a grid operator).	[11,13, 15–17]
Grid Congestion Re-lief	The ability to provide power or reduce demand in a system where the transmission lines cannot carry additional electricity due to thermal, voltage, or stability limits.	[18–22]
Transmission and Distribution Deferral	The ability to delay the replacement of transmission or distribution system equipment by utilizing DR/DER to keep power demand of that equipment below its operating limit or by allowing it to be utilized in a manner that extends its operating life.	[7,18,21,23, 24]

the utility to control some aspect of its customers' energy consumption in order to provide relief during times of peak energy consumption. Many differing types of customer-owned assets can be utilized in DR, such as air conditioners, water heaters, heat pumps, and a number of larger, commercial-sized assets such as pumps and refrigerators [27]. The California ISO (CAISO) was one of the first market makers to enable participation of DR into their market in the early 2000s [28].

Remote control of DR assets was first demonstrated in the early 1970s [29], though the concept of DR aggregation was more formalized in the mid-1980s [30]. The concept of DER aggregation, also commonly referred to as a virtual power plant (VPP), followed and was first introduced as a concept in the 1990s. Numerous researchers and practitioners eventually came together at the *Symposium on the Virtual Utility* in 1996, citing their motivation to gather as research into the integration of new technologies, such as renewables or "other modular options", enabled by recently developed communication technologies in order to better provide flexibility and supply/demand balance. The goal was to do this in a manner that developed a new, more appropriate process for the integration of these technologies rather than trying to integrate them utilizing old processes that may not adequately capture all of the benefits they could provide [31].

Since the *Symposium on the Virtual Utility*, research exploring the provision of energy for DER aggregators and load flexibility for DR aggregators into wholesale markets has grown substantially. Additionally, this research has broadened to include the supply of GS, also commonly referred to as ancillary services, into wholesale electricity markets. A detailed discussion on the varieties of GS and their technical requirements is outside the scope of this paper, but detailed information on this topic can be found in Ref. [32]. On the DR side, it has been noted that loads that provide a quick and reliable response to a signal to reduce demand are best suited for the provision of some GS, such as frequency regulation [33], and a number of studies confirmed early performance of aggregated DR resources in wholesale power markets [7,9,34,35]. Research into DER aggregation has also confirmed the capability to provide GS into wholesale power markets [7–14].

2.2. Modeling architecture

Research examining the value of DR/DER in wholesale markets has largely utilized the same architecture that bulk energy system modelers have been using for central generation assets. The most common of these is unit commitment, which can be generally described as a modeling approach that seeks to commit all generating assets on the power system, subject to the power system constraints, in an optimal manner –

usually defined as lowest cost of operation. Constraints accounted for typically include the minimum up- and down-time, ramp-rate limits, and turn-down limits of generating assets as well as electricity demand, reserve requirements, and some transmission limits for the broader electricity system. Since lowest cost operation is usually sought, capital costs for generating assets are generally not included, but any fuel costs, operations and maintenance costs, and start-up costs are included in the optimization [36]. There are a wide range of commercially available unit commitment model software packages available now, including PROMOD, GE-Maps, Plexos, Gridview, and PSO [37].

While unit commitment broadly focuses on the performance of the system given a set of generating assets, there are two approaches within a unit commitment model that examine the value of a new generating asset (or demand reduction, in the case of DR) being added to a system. A *price-taker* approach assumes the newly added generating asset has no effect on market price and will therefore receive the same market price for energy or services that existed before the addition of the new asset. The *price-maker* approach assumes that the new generating asset will affect market price and therefore a new market price must be calculated after the addition of the new asset to the system [38].

While unit commitment can estimate a value for aggregated DR/DER generally, to more accurately predict the operational characteristics of aggregated, customer-owned DR or DER assets in a realistic manner it is critical to account for consumer (DR/DER owner), aggregator, and/or system operator motivations. Most existing research has attempted to do this by maximizing the benefit that any one of these market participants receives from DR/DER aggregation. Early research into DR aggregation tended to look at maximizing the benefit to the individual consumer providing the DR [39]. presents this type of approach, amongst others, where a consumers benefit is a function of both energy cost and benefit from using differing types of appliances or lighting in a home. A simple 8-home aggregated system is then modeled based upon this optimizing this function under differing potential pricing schemes defined by the utility.

More recently, many of the studies on DR/DER aggregation have optimizing benefit for the aggregator [40]. looks at how a DR aggregator might minimize their own operational cost and proposes two methodologies on how DR might be scheduled by the aggregator once bids have been received and total power demand is known [41]. attempts to minimize aggregator cost through dynamic pricing, thereby providing an incentive to asset owners to make DR available when it is most advantageous to the aggregator [42]. seeks to maximize aggregator profit in the case where the size of the aggregated assets is large enough to impact pricing on the wholesale market.

Additionally, other researchers have explored maximizing the benefit to system operators with aggregated DR/DER assets. Much of this research looks at DR and is older, as many early DR programs were focused on providing benefit in the form of peak shaving to the grid operator. However, there has been recent work that looks at DR/DER aggregation through the lens of system operator benefit beyond peak shaving [43]. looks allocating DER across the Italian electricity network with a goal of minimizing electricity generation cost across the system, utilizing a genetic algorithm to arrive at a solution [44]. explores bidding aggregated DR in the day-ahead market with the goal of minimizing system electricity generation cost, using the IEEE 6-bus system as a test system and implementing a linear programming approach to arrive at a solution.

Finally, a subset of the aggregation research has taken a multi-objective optimization approach where the primary goal is to optimize for one of the market participants while also minimizing the impact of the aggregation on one or both of the other types of market participants as a secondary goal. For example [45], looks at maximizing the utility of DR owners while also minimizing the cost imposed on energy generators, proposing a real-time pricing algorithm that assumes utility functions are non-decreasing, marginal benefits to customers are non-increasing, customers can be ranked based upon their utilities,

and that no power consumption provides no benefit [46]. builds upon this work and proposes a Vickrey-Clarke-Groves (VCG) mechanism to gather information from rational consumers so that a specific payment value can be offered preemptively to them by an energy provider, as opposed to allowing consumers to anticipate pricing on their own and act accordingly. The goal of this approach is to maximize the utility of all parties in the transaction.

2.3. Modeling methodology

There are a variety of methods that have been utilized to examine DR/DER economics within a unit commitment architecture. One of the most common is mixed-integer linear programming (MILP) [42]. assumed aggregated DER was a price-maker and used MILP to evaluate how to maximize the aggregators profit. Three scenarios – one deterministic, one stochastic, and the third a deterministic representation of the most likely stochastic scenario – were examined, and it was found that DER aggregator profit was maximized at a market share of 3–4% of total power generation [47]. also sought to maximize aggregator profit using a set of heuristics. Performance in a day-ahead energy market was modeled and a MILP was used in the optimization. It was found that consumers also realized considerable savings when the aggregator profit was maximized [13]. added the evaluation of the regulation market in addition to the wholesale energy market and proposed a MILP to optimize the simultaneous participation of aggregated DER in these markets. The optimization objective was to minimize the cost of the aggregated DERs while allocating DER capacity to each market. A case study was run looking at the Norwegian electricity market, where it was found that the aggregation reduced the power cost of the individual DER owners up to 4% over the five-week period studied [48]. also uses MILP but adds an *Auto Regressive Integrated Moving Average* (ARIMA) model for scenario generation in a situation where DR can be procured by energy retailers from aggregators via fixed contracts under two differing option schemes. This effectively allows energy retailers to operate with greater or less risk and it was found that risk-neutral energy retailers procure 10% of anticipated load from DR, while conservative energy retailers procure 25% of their anticipated load from DR.

In addition to the more popular MILP, there are a number of other solution methodologies that have been utilized to look at aggregated DR/DER performance in unit commitment models [49]. utilized a *Monte Carlo* approach to represent the potential behavior of aggregated CHP units in providing balancing services for wind generation, specifically examining the Dutch energy market. The heat and electricity profiles and heat energy storage level from each home on the system were simulated using the Monte Carlo methodology and it was found the aggregated CHP reduced imbalance volume by 73% and costs associated with imbalance by 38% [50]. focuses on methodologies to find an optimal bid strategy for aggregated DER. A *genetic algorithm* was proposed to find a solution that maximizes the profit of the aggregator when including market revenues and penalties for violation of constraints in the unit commitment model.

[51] used a *mathematical program with equilibrium constraints* (MPEC) approach when examining the bid strategy of a DR aggregator trading with a wind power producer on the Nordic market. The MPEC was utilized as there were multiple objective functions associated with maximizing the wind power producer's profit and the DR aggregator profit. The MPEC allowed these two objective functions to be reduced to a singular objective function and it was found that wind power producers would procure DR as a risk hedging strategy during times of high price, while selling DR to the aggregators during times of low price. Another methodology to solve problems with multiple objective functions, *mix complementary problem* (MCP), was used in Ref. [52] to look at aggregated DER in a situation where all market participants are seeking to maximize their profit. A representative model of an urban area was examined and cases with assumptions of perfect and imperfect competition within the market were explored, with potential DER investment

behavior under these various scenarios calculated. A *non-linear programming* (NLP) approach was taken in Ref. [53] to schedule DR from aggregated residential appliances on the Ontario electricity system. A cutting plane method, a form of NLP, was used to solve the optimization function that sought to minimize electricity cost for the appliances.

2.4. Enablement of DER aggregation via information and communication technologies

The invention and deployment of advanced communication technologies is widely recognized as a key technical development that enabled broader deployment of DER technologies. Starting in the 1960s with the demonstration of packet switching technology [54] and the subsequent creation of ARPANET [55], by the 1970s *local area network* (LAN) technology connecting multiple computers in separate locations was well established. Work on the Open Systems Interconnection (OSI) framework to connect multiple computer networks was started in 1977, resulting in the release of the OSI scheme in the early 1980s [56]. Interconnected computer networks are the backbone on which DR and DER aggregation rely, and OSI defines whom is communicating, required data properties, and control methodologies for these networks.

In order for DR or DER assets to be aggregated and participate into wholesale markets there is an additional communications protocol necessary to bring together the communications technology defined by these communication standards and the OSI protocol. OpenADR [57] was created at Lawrence Berkeley National Laboratory (LBNL) in the early 2000s [58] in order to accomplish this. OpenADR allows grid operators to communicate with the owners and/or operators of DR and DER assets via real time price signals and/or DR event signals and provides profiles for DER operation, which is necessary for these assets to participate in wholesale markets.

More recently, *Distributed Ledger Technology* (DLT) has been a topic of increasing research interest based upon its potential to reduce friction within wholesale markets and/or eliminate the need for a third party to operate as a centralized aggregator. It should be noted that blockchain technology is used interchangeably for DLT within academia, industry, and media; however, blockchain technology is only a subset of DLT [59, 60]. In its most basic form, DLT is a digital database that is verified based upon a consensus mechanism performed by disaggregated parties, without anyone playing the role of a centralized authority. This enables economic transactions between parties to occur and be recorded without the need of a third-party playing the role a trusted intermediary – and thereby eliminates the friction and cost associated with that role. An overview of recent developments and standards in DLT can be found in Ref. [61].

There are three common consensus protocols utilized to establish trust between parties participating in a DLT, *proof-of-work* (PoW), *proof-of-stake* (PoS), and *proof-of-authority* (PoA). PoW consensus mechanisms utilize a moderately difficult mathematical problem [62] which can adjust its complexity according to factors such as total available processing power within the blockchain network and the blockchain network load. The PoW consensus mechanism can result in significant power usage, however, causing it to fall out of favor for clean energy applications; for example, according to recent estimates the energy demand of the Bitcoin network, which utilizes a PoW consensus mechanism, ranges from the size of a mid-level power plant to a country the size of Belgium [63]. Therefore, PoW consensus mechanisms may not be favorable for DER applications due to clean energy being a driving force behind DER generally as well as the potential to negate some of the benefits DER provides (for example, congestion relief) if some or all of the PoW calculation is taking place on the same distribution system that the DERs are installed on. Instead, PoS and PoA may be preferred for most DER applications due to their less intensive energy needs [64].

In response to this shortcoming of PoW, and to provide better protection against 51% attacks (a type of cyberattack where the attacker gains control of more than 50% of the blockchain network, allowing

them to control it) [65], PoS type consensus mechanisms were developed. In PoS, achieving consensus among the participating agents, or nodes, is done via assignment of randomly chosen nodes. The probability of any individual agent being chosen is dependent on how much they have staked in the blockchain network. The stake is typically a cryptocurrency and is similar in practice to an ownership share of the network. The PoS mechanism is built upon the idea that the nodes with the most stakes in the blockchain will have the strongest motivation to keep the chain intact and accurate. However, the downside of PoS is the fact that, unlike PoW, it is a virtual mining process where, instead of mitigating potential bad behavior through the cost of electricity and physical mining infrastructure, the miners can simply acquire stakes in the network. This opens PoS networks to nothing-at-stake problems [65].

PoA is a third consensus mechanisms that tries to address shortcomings of the other two. In the PoA mechanism the “blocks” in the network can be validated only by pre-approved nodes that are known as validators. Validators are incentivized, often through the payment of a token, to keep the network correct and problem free in order to keep their reputation level. However, if the validators reputation level in the network starts to diminish they lose their approval status and a new validator may be chosen [66].

The use of DLT technologies in electricity markets is a relatively new topic that still largely lies in the academic realm. Limited discussion exists of DLT use in ISO/RTO markets likely due to the fact that these markets are operated by a third-party, whom therefore has limited benefit from the use of the technology and significant risk to its business model should implementation occur. With that said, ISO/RTOs generally serve not only as a market operator but also as a balancing authority that ensures electricity supply meets demand. Therefore, while DLT might be able to replace the economic transaction functions currently completed by ISO/RTOs [67], DLT alone may not be able to replace the electricity balancing function performed by these entities.

There are purely economic transactions that do take place on the bulk electricity systems, however, where use of DLT has been explored. Considerable electricity trading occurs on bilateral or over-the-counter (OTC) energy markets, such as the one operated by the Intercontinental Exchange (ICE) in the U.S [68]. Additionally, the majority of electricity trading in continental Europe takes place on such a basis [69]. DLT could eliminate the need for these third-party market makers as well as allow for the development and trial of new trading instruments without the need to disclose the identity or, as importantly, the strategy of the party initiating the trade [70]. [67] provides an overview of some of the opportunities and potential regulatory challenges in implementing DLT for OTC electricity trading in Europe and conducts a survey of a number of European OTC electricity market participants to gather feedback on what they believe the benefits and limitations of DLT in this context might be. The survey finds that the opportunity for reduced transaction costs is far-and-away the most cited potential benefit of DLT, with regulatory and intermediary conflict concerns being identified as the largest barriers to implementation.

2.5. Implementation and deployment

Despite the prescient nature of the challenges and opportunities of DER aggregation presented at the *Symposium on the Virtual Utility* in 1996, adoption of this approach in the electricity sector was slow. This can likely be attributed to a combination of the nascent stage of DER technologies and the communication technologies necessary to integrate them as well as a lack of incentive for utilities to adopt this approach relative to their existing business model. However, by 2016 the CAISO had established a program that allowed for aggregated DERs to participate in their market [71], making them once again an example of one of the first market makers to try and enable the participation of aggregated technologies. Adoption was not quick, though, as after one year there were only 4 aggregators participating in the market [72].

Citing traditional rules for ISOs/RTOs as barriers limiting the services that new technologies can provide as motivation for change [6], FERC passed Order 2222 in September 2020 in order to “remove barriers to the participation of distributed energy resource aggregations in the RTO and ISO markets”. Order 2222 requires all U.S. ISO/RTOs, with the exception of the Electric Reliability Council of Texas (ERCOT), to revise their market rules to establish DER aggregators as a market participant and create a participation model that allows for the specific physical and operational characteristics of DER aggregation. The order sets a minimum size threshold of no more than 100 kW for participation in U.S. wholesale markets and required all U.S. ISO/RTOs to implement the rule within 270 days of its passing [5]. However, the New England ISO (ISO-NE), Southwest Power Pool (SPP), Mid-Continent System Operator (MISO), and PJM have been granted an extension to implement these rules to various dates that fall in 2022 [84,85], though the CAISO and New York ISO (NYISO) did file on time and plan to implement the changes required by the 4th quarter of 2022 [86].

The continued implementation of policy enabling the participation of aggregated resources into wholesale markets, like FERC Order 2222 in the U.S., is likely to grow the number of aggregated resources participating in wholesale markets [10]. provides a thorough overview of 144 business models for DR and DER assets, many of which include aggregation, and discusses how policy and regulatory frameworks are largely defining which business model approach must be taken across the globe. There are already a number of companies that are aggregating DR and/or DER resources for participation in these markets; Table 2 provides an overview of some specific companies that are offering DR/DER aggregation solutions [18]. also details utility led aggregation pilots in the U.S. through 2018, including a detailed case study on 5 specific pilots.

Wholesale energy market trading using DLT is, generally, in a nascent stage and when combined with the early stage of aggregated DR/DER approaches it is unsurprising that there is little commercial activity trading aggregated DR/DER in wholesale markets with DLT. With that said, there are dozens of companies developing wholesale market products broadly that utilize DLT and a few early commercial products have emerged. One such example is Enerchain, which was launched commercially on May 20, 2019. Enerchain is fundamentally an energy marketplace utilizing Blockchain to record transactions between parties trading on the marketplace. Over 40 primarily European utilities participated in a pilot phase during 2017–2018 and the marketplace is

Table 2
Aggregator participation in wholesale markets.

Company	Currently Participating Market (s)	Notes
Enel [73]	Italy, New York	Aggregation business was purchased through acquisition of ENERNoc [74].
CPower [75]	CAISO, ERCOT, ISO-NE, NYISO, PJM	Partnered with Sunnova to bid aggregated solar portfolio into NE-ISO capacity auction [76].
NRG [77]	CAISO, ERCOT, ISO-NE, NYISO, PJM, Ontario	Acquired Energy Curtailment Specialists to enter into aggregation [78], now focused on aggregating DR/DER at a single, commercial customer site.
IPKeys Power Partners [79]	PJM, CAISO	Acquired North America Power Partners to enter into aggregation [80].
BluePrint Power [81]	NYISO	Focus on commercial buildings, primarily operating in New York City currently.
OhmConnect [82]	CAISO	Pay individual residential homeowners to sign up to DR then aggregate for participation in market.
Swell Energy [83]	CAISO, Hawaii, NYISO	Residential customers sign up and can get various DER solutions installed, Swell manages DER aggregation in specific markets.

now open to everyone [87].

3. DERS in local (distributed) energy markets

3.1. Background

The second option that has been explored for DERs to participate in energy markets is the creation of *local energy markets* (often referred to as distributed energy markets). Fig. 1 shows the distinction between how DERs may participate in wholesale markets and a local energy market. As generally envisioned, these are markets where electricity is traded at the distribution system level, with electricity from the bulk system simply treated as another participant in the market. This type of localized energy trading on the distribution system is broadly referred to as *transactive energy* (TE). TE, conceptually, consists of DER owners trading energy with their local neighbors, serving to more appropriately balance local energy supply with demand through price signals and, by association, minimizing transmission losses. More wholistically, the National Institute of Standards and Technology (NIST) states that TE benefits consumers by utilizing the assets on the grid more effectively, providing improved reliability and resilience during large storms, giving increased choice to consumers as to how their energy is sourced, and by providing increased consumer satisfaction through the use of renewables that contribute to societal goals [88].

Local energy markets represent the final phase of distribution system evolution [89] and could be realized through a number of differing market structures. The first is simply participation in wholesale markets, conceptually similar to described in Section 2 but with fewer restrictions on their participation. The second is an operational market, where a distribution utility ensures supply and demand are met along with any necessary GS. A third option is a distribution level energy market where market participants, including individual DER owners, can trade energy [89].

To realize any one of these market options, the DSO concept must be introduced. NARUC has defined a DSO as “the entity responsible for planning and operational functions associated with a distribution system that is modernized for high levels of DERs”. The idea of DSO has been introduced to solve the dual challenges of managing high levels of DER while maintaining grid reliability and addressing the need to coordinate resource dispatch across all levels of the energy system – specifically the DER asset owner or operator, the bulk system operator (ISO/RTOs), and the distribution utility [90].

There are three DSO models that have been proposed. In a *Total DSO* model the distribution utility effectively takes on the same role as an ISO/RTO at the distribution level. Under this model, the DSO would coordinate with an ISO/RTO in order to ensure both agents are coordinated at any substation connecting the distribution system and the bulk power system, but the DSO would be responsible for all energy balancing on the distribution system. In this model, the DSO would also be responsible for DER participation on the wholesale energy market, effectively behaving as a DER aggregator. The *Minimal DSO* model adds an additional responsibility of ensuring any necessary distribution grid improvements to maintain reliability with greater DER deployment to the role of the distribution utility, but otherwise their role is unchanged. All DER integration responsibilities would go to the ISO/RTO operating the bulk power system under this model [91]. The *Independent DSO* is the third model that has been proposed. With this model, the distribution utility maintains responsibility for the distribution grid – becoming a so-called “wires-only” company – but the market-making and grid balancing function on the distribution system would fall to an independent third party, similar to an ISO or RTO on the bulk energy system [89].

3.2. Modeling architecture

To have a local energy market there must be a method to price electricity at various points in the distribution system, which ultimately is intertwined with the DSO model chosen. There have been a variety of approaches proposed for market clearing in a distributed energy market. Many of them can be generally categorized as *distributed methods* for market clearing, meaning that the clearing function is shared across numerous decision makers. Some specific distributed methods include [92]:

- **Decomposition**, where rather than trying to solve a single, complex optimization the problem is broken into several smaller, less complex optimization functions. For example, a centralized coordinator (such as a DSO) could allocate resource between all participants and then these individual actors optimize their own use of their allocation.
- **Networked optimization**, where a communication structure between all parties involved in the market is defined and then decomposition occurs based upon that defined network structure.

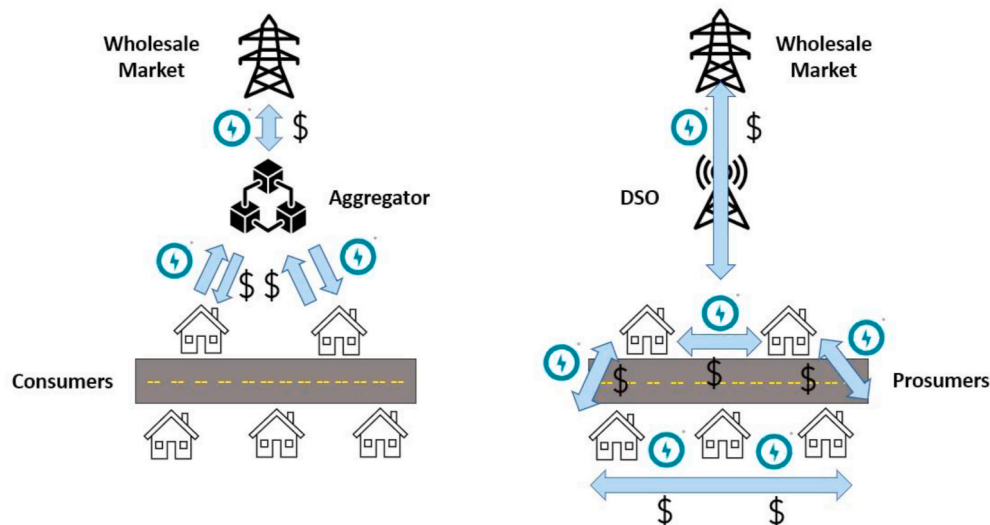

Fig. 1. To participate in wholesale energy markets, given current restrictions, DER assets are aggregated and all DER economic and energy transactions go through the party performing the aggregation (left). In a local energy market approach, DER owners can trade with each other, their neighbors, and the grid with a DSO serving as a market maker and providing various grid functions, dependent upon DSO model chosen (right).

- **Game-theory**, which can be used to define how market participants may behave (for example, cooperatively or non-cooperatively) and therefore, ultimately, price energy on the market.
- **Agent-based**, where each individual involved in the market can have their behavior defined by a mathematical function.

The most common mechanism for pricing put forward to price electricity throughout a distribution system is an extension of the traditional *locational marginal price* (LMP) mechanism used for transmission systems [93] to establish a *distribution locational marginal price* (DLMP) framework. The pricing mechanism in a LMP framework has traditionally accounted for the price of the electricity generated, power losses as electricity is transmitted along power lines, and congestion in the transmission system caused by electricity flowing to and from multiple sources. DLMP was first proposed as “nodal pricing” in 2006 in Ref. [94] and early DLMP work dropped the congestion component of LMP due to the rarity of congestion on the distribution system without high penetration of DER [95], resulting in DLMP being composed solely of energy and energy loss.

More recent work, however, has added the congestion component in to DLMP [96,97] as a key component utilized in the methodology for calculating DLMP. These congestion inclusive methods were first established in work that looked at the bulk transmission system before finding use in distribution system models. The methodologies that account for congestion broadly fall into three categories: *transaction-based*, *congestion control*, or *optimal power flow* (OPF) [98]. In transaction-based methods, any proposed power transaction has its impact on the grid calculated before the transaction is approved. For example, in the late 1990s the North American Electricity Reliability Corporation (NERC) proposed and then standardized the use of a DC linear power flow model of the U.S. power grid, called the Interchange Distribution Calculator, to approve any transactions on the U.S. power grid [99].

Congestion control methodology allows the market participants to control congestion directly. There are generally three types of market participants, each with a separate responsibility. A *system operator* operates the transmission system itself. The *market operator* defines and runs the energy market(s), generally including at least a day-ahead and real-time market. The *market participants* then buy and sell energy within the marketplace. Congestion is then ultimately managed through tariffs paid to the system operator for connecting to transmission, definition of price areas by the system operator when congestion is predicted in the day ahead market (with forced spot market participation if congestion does exist), and energy buybacks by the system operator if congestion does occur in the real-time market [98].

The third congestion management tool, OPF, is simply a set of equations, including representation for the constraints of the transmission system, that generally seeks to minimize the cost of electricity generation [99]. OPF methodology can be further categorized as *DCOPF* or *ACOPF*. ACOPF was formulated in 1962 and optimizes real and reactive power dispatch. The pricing mechanisms are non-linear and the use of AC power flow also introduces non-linearities. This ultimately requires the linearization of parameters or other simplifying assumptions to solve the ACOPF, and even with those relaxations the solution tends to remain computationally intense [100]. DCOPF, on the other hand, uses DC power flow and generally only considers a set of equations that account for production cost, line congestion, and line loss that are easily solvable through less computationally intensive linear programming [101]. This relative ease of computation made DCOPF the generally favored approach as late as the early 2010s, though more recent increases in computing power have helped to increase adoption of the ACOPF modeling approach.

3.3. Modeling methodology

The first paper proposing solutions for DLMP simply utilized a set of non-linear equations that accounted for the demand for and cost of

active and reactive power at each node. *Karush–Kuhn–Tucker* (KKT) conditions were then applied to arrive at an optimal solution [94]. KKT has since become a favored approach used to solve decomposition models [102]. uses KKT to solve an incremental welfare consensus algorithm on a grid with both DER and DR. The proposed algorithm seeks to maximize the welfare of both the generators and the energy consumers and is implemented over systems of various size to show its ability to scale to systems with larger numbers of nodes [103]. uses KKT to solve a bi-level model where the upper-level is a security constrained model of the distribution network and the lower-level model is the day ahead market clearing of the ISO. This approach is then applied to price electricity at each of the 33 nodes of a test distribution network and 6 nodes of a test transmission system on which 6 DERs and 32 DRs have been deployed.

Networked optimization is often solved with the use of *graph theory*, which is an approach that identifies which individuals in the network are in some way related to one another [104]. uses graph theory to look at a distribution system where storage devices and DER generators are located with the goal of minimizing the production cost of electricity on the system. The graph theory solution treats each of the storage devices and DER generators as if they are coordinating to achieve this goal, and the approach is utilized to price electricity at each of the nodes on the IEEE 6-bus system [105]. utilizes graph theory with the same coordination approach and objective of minimizing system cost but looks at distributed generators and load only. Case studies are run on a 39-bus system with 29 agents and a system with 1400 agents and performance is ultimately validated on the PNNL VOLTTRON testbed.

[106] contains a thorough overview of the various game theory solution approaches for both competitive and noncompetitive games that have been applied in the research to distribution energy networks. *Auction games*, *coalitional games*, and *hierarchical games* are noted as being used frequently in the literature for energy trading with DERs. Auctions can be for the sale of a good or service, where usually the highest bidder(s) wins, or for the procurement of a good or service, where the winner is usually the lowest bid(s) [107]. discusses a situation where multiple DERs are selling to a single load via an auction game and simulates such a scenario. A coalitional game is one where players group together in some fashion and cooperate with one another within each individual group [108]. explores this type of game where DER owners and end users seek to trade with one another or with an energy retailer, using an asymptotic Shapley value to determine the price of electricity. Hierarchical games are ones where players have differing levels of status, which affects their ability to compete in the game [109]. takes this approach in looking at how individual home, single units in an apartment complex, or aggregated storage units, located in a community might choose to store energy or provide DR.

Solutions to agent-based methods generally utilize a *multi-agent framework* approach, with the specifics of the mathematical method varying based upon the complexity of the system and the function defining each agent’s behavior [110]. proposes a multi-agent simulation where DER owners, load aggregators, DSOs, and regulators, each of whom have their behavior defined by a different function, are participating in a local energy market. Python is then used to conduct simulations of a variety of cases, using the IEEE 33-bus system to define the electrical system characteristics [111]. also uses a multi-agent simulation, with the agents consisting of intermittent generation owners, load aggregators, energy managers, local market auctioneers, and energy markets, to trade energy in and between microgrids with the goal of minimizing forecasted energy imbalance. A case study is then performed on a derivation of the IEEE 37-bus system.

As previously noted, most work exploring DLMP using a OPF methodology has used DCOPF [112]. creates a DCOPF structure and then proposed the *interior point method* to solve the non-linear problem. A control structure utilizing this DLMP estimation is then implemented on the Roy Billinton Test System (RBTS) with various PV and storage installations and load sizes. It was found that coordinating the PV and

storage via this control structure produced an overall energy cost reduction [97]. uses DCOPT and the RBTS to look at optimizing EV charging. An objective function that looks at the benefit of meeting all non-EV energy demand and a function defining the cost of supplying the energy to meet all demand, including that from EV's, were defined and KKT was applied to solve the OPF, with three case studies using Danish driving data showing that the DLMP approach helped to spread out EV charging time over the course of the day.

More recent literature, however, is exploring the more complex ACOPF approach [113]. proposes a day-ahead market framework and market-clearing model for a DSO maintaining a smart distribution grid with various types of DERs. Active power, reactive power, congestion, voltage support, and loss are considered in the model, which has a goal of maximizing social welfare. The *trusted region* approach is used to solve the model and the IEEE 33-bus distribution system is used to test the model before it was implemented on grids with 141, 564, and 1128 nodes [114]. also uses an ACOPF model to explore the impact of distributed generation on the distribution system. Active power, reactive power, and reserves are considered in the model, which seeks to minimize total system cost, and a *second-order-cone relaxation* is adopted to solve the model. The IEEE 33-node distribution system is then used to look at the impact of varying the location and size of distributed generation has on DLMP and reserve requirements.

3.4. Enablement of local energy markets via information and communication technologies

The establishment of local energy markets fundamentally relies on the same physical information and communication technology as described in Section 2.4. However, new digital technology developments, such as DLT and *Machine Learning* (ML), are also playing a key role in accelerating interest in local energy trading. The use of DLT in smart grids can allow DER owners to become *prosumers*, selling any excess energy generated or grid services provided by their DER(s) to other local grid participants while purchasing energy from those same participants during times where DER energy supply does not meet their need [115]. This type of localized energy trading between individuals located on the same distribution system is often referred to as *Peer-to-Peer* (P2P) energy trading as proven by Refs. [116–118]. ML can be utilized in local energy trading by aiding in the execution of key functions such as forecasting, load and price optimization [119,120], fault detection, and cybersecurity [121,122]. While both DLT and ML are key digital technologies in the enablement of local energy trading, ML has already received outsized attention; therefore, this paper will focus on the interaction of DLT with local energy markets.

P2P energy trading does not require the use of DLT, but the use of DLT for this application is of increasing interest because of its ability to reduce transaction costs by eliminating a third-party market maker, enable anonymity in trading, and the transaction security it can provide [123]. There have been a wide range of academic studies on the use of various specific DLT technology options, such as Blockchain or Ethereum, for P2P energy trading. These studies have explored application of DLT in P2P for energy trading from specific technologies such as EVs [124], for the use of tracking energy loss [125], and to provide an energy trading platform [126–129].

3.5. Implementation and deployment

The concepts of local energy markets or P2P energy trading has only existed for approximately 15 years, so commercial application is still in its nascency. Additionally, as many places in the world have electricity services managed by large utilities and/or ISO/RTOs to whom localized energy trading represents a competitor, there is a natural desire to prevent broad commercialization of these new approaches. Nonetheless, there have been a number of demonstration efforts and a few companies that are commercializing the concept. There are a few of these efforts

that utilize traditional currency for local energy market of P2P trading. One of these is *sonnenCommunity*, which allows users in Germany, Italy, Switzerland, and Austria to use their batteries and/or PV systems to trade energy with one another [130]. However, the vast majority of these demonstration or early commercial efforts are focused on the use of DLT technologies to enable energy trading. Table 3 provides an overview of a number of the demonstrations or offerings.

4. Conclusion

Improvement in DER technologies, such as those highlighted in Ref. [130] will continue to drive down cost and increase the number of people whom will be able to utilize the technologies. Coupled with continued improvement in associated communication technologies, the number of ways and the number of parties that will be able to interact with electricity markets will continue to expand. New approaches are being developed for DERs to participate in wholesale energy markets at the same time that solutions, born of an inability for DER to access wholesale markets and a desire to avoid the costs associated with third-party market makers, are being created so that they may not have to. Modeling approaches to explore how the economics of DER may play out in these differing markets are rapidly increasing, as early exploration of DER participation in these markets is only about two decades old. Additionally, the development of DLT technologies are only expanding the modeling approaches and number of ways that DER owners and operators may be able to perform transactions with the energy assets they own.

This review is a snapshot in time of the approaches to integrating new DER technologies into electricity markets or approaches that create new markets more appropriate for these technologies. Given the important role these technologies will play in the decarbonization and democratization of the electricity sector, finding ways to allow these

Table 3
Demonstration projects and commercial products offering local energy trading with DLT.

Project/ Company	Location	Notes
EMPOWER [131]	Europe	Started January 2015 to create a local energy market for DER trading. Effort was a lab-based simulation in 2015, with a pilot starting in Sweden in 2020 [132].
NRGCoin [133]	Europe	Presented as a concept in 2014, DER owners receive NRGCoin, a form of cryptocurrency, in return for injection of clean energy into the grid. A simulated demonstration was run using Flemish data in May of 2014 [134].
P2P-SmarTest [135]	Europe	Started in 2015, set up a local market to enable local trading of energy from DER and flexible load from DR. Demonstration occurred between a number of Spanish microgrids in 2016 and project was completed in 2017.
LO3 Energy [136]	U.S., Japan	Started in 2015, offer a digital marketplace called Pando based upon blockchain for P2P DER trading. Marketplace has been tested in at least 10 pilots across the globe.
Hive Power [137]	Europe (based in Switzerland)	Offer a marketplace solution based upon Blockchain for a wide variety of DERs and DR. Have demonstrated performance on pilots in Germany, Sweden, and Switzerland.
Powerledger [138]	Based in Australia, have projects in U.S., Europe, Asia, and Australia	Started in 2016, provide a blockchain-based energy trading platform for DER and DR. Currently have 20 active projects across the globe.

technologies to earn appropriate compensation while also understanding the greater impact they will have on compensation to other grid assets - such as those described in this review - is critical. The continued development and deployment of DER technologies, evolving approaches to capture the potential economic impacts of their use, and the continued improvement in communication technologies such as DLT described above will require continued monitoring and new or updated reviews such as this one. But most important of all, while commercial offerings based on a variety of these approaches are currently in their nascency, but continued cost declines in DER and a desire by consumers to control their own energy generation as well as find ways to reduce the environmental consequences of energy generation will continue to drive growing commercial interest and, by association, continued research interest in solutions to trading DER generated energy.

Declaration of competing interest

The authors declare that they have no known competing financial interests or personal relationships that could have appeared to influence the work reported in this paper.

References

- [1] Public Utility Regulatory Policies Act of 1978, 16 U.S.C. §2601, <https://uscode.house.gov/view.xhtml?path=/prelim@title16/https://uscode.house.gov/view.xhtml?path=/prelim@title16/chapter46&edition=prelim> 1978).
- [2] 16 U.S.C. §2601.
- [3] NARUC, NARUC manual on distributed energy resources compensation. <https://pubs.naruc.org/pub.cfm?id=88954963-0F01-F4D9-FBA3-AC9346B18FB2>, 2016.
- [4] E. I. A. U.S. Department of Energy, Net Metering Customers and Capacity by Technology Type, by End Use Sector 2009-2019, [https://www.eia.gov/electricity/annual/html/epa\\$. \\$04\\$. \\$10.html](https://www.eia.gov/electricity/annual/html/epa$. 04. $10.html), Accessed September 6, 2021.
- [5] U.S. Department of Energy, Federal Energy Regulatory Commission, Order No. 2222, 172 FERC 61, 247. 18 CFR Part 35. Docket No. RM18-9-000. [https://www.ferc.gov/sites/default/files/2020-09/E-1\\$. \\$0\\$. \\$0.pdf](https://www.ferc.gov/sites/default/files/2020-09/E-1$. 0. $0.pdf).
- [6] U.S. Department of Energy, Federal Energy Regulatory Commission, Notice of Proposed Rulemaking, 157 FERC 61,121, 2016. [https://www.ferc.gov/sites/default/files/2020-06/RM16-23-000\\$. \\$AD16-20-000.pdf](https://www.ferc.gov/sites/default/files/2020-06/RM16-23-000$. $AD16-20-000.pdf).
- [7] K. Ardani, E. O'Shaughnessy, P. Schwabe, Coordinating Distributed Energy Resources for Grid Services - A Case Study of Pacific Gas and Electric, Tech. Rep. NREL/TP-7A40-72108, National Renewable Energy Laboratory, Golden, CO, USA, 2018. <https://www.nrel.gov/docs/fy19osti/72108.pdf>.
- [8] M. Motalleb, M. Thornton, E. Reihani, R. Ghorbani, A nascent market for contingency reserve services using demand response., Appl. Energy 179 (2016) 985-995, <https://doi.org/10.1016/j.apenergy.2016.07.078>.
- [9] J.H. Eto, J. Nelson-Hoffman, C. Torres, S. Hirth, B. Yinger, J. Kueck, B. Kirby, C. Bernier, R. Wright, A. Barat, D.S. Watson, Demand Response Spinning Reserve Demonstration, Tech. Rep. LBNL-62761, Ernest Orlando Lawrence Berkeley National Laboratory, Berkeley, CA, USA, 2007. <https://www.osti.gov/servlets/purl/925589>.
- [10] S.P. Burger, M. Luke, Business models for distributed energy resources: a review and empirical analysis., Energy Pol. 109 (2017) 230-248, <https://doi.org/10.1016/j.enpol.2017.07.007>.
- [11] C. Eid, P. Codani, Y. Perez, J. Reneses, R. Hakvoort, Managing electric flexibility from Distributed Energy Resources: a review of incentives for market design., Renew. Sustain. Energy Rev. 64 (2016) 237-247, <https://doi.org/10.1016/j.rser.2016.06.008>.
- [12] M. Motalleb, M. Thornton, E. Reihani, R. Ghorbani, Providing frequency regulation reserve services using demand response scheduling, Energy Convers. Manag. 124 (2016) 439-452, <https://doi.org/10.1016/j.enconman.2016.07.049>.
- [13] A. Roos, S. Ottesen, T.F. Bolkesjø, Modeling consumer flexibility of an aggregator participating in the wholesale power market and the regulation capacity market, Energy Proc. 58 (2014) 79-86, <https://doi.org/10.1016/j.egypro.2014.10.412>, renewable Energy Research Conference, RERC 2014. doi:10.1016/j.egypro.2014.10.412".
- [14] S. Kiliccote, M. A. Piette, E. Koch, D. Hennage, Utilizing Automated Demand Response in commercial buildings as non-spinning reserve product for ancillary services markets, in: 2011 50th IEEE Conference on Decision and Control and European Control Conference, vol. 2011, pp. 4354-4360. doi:10.1109/CDC.2011.6160988.
- [15] K. Al-Salim, I. Andonovic, C. Michie, Cyclic blackout mitigation and prevention using semi-dispatchable standby generation and stratified demand dispatch, Sustainable Energy, Grids Networks 4 (2015) 29-42, <https://doi.org/10.1016/j.segan.2015.09.002>.
- [16] A. Zibelman, E.N. Krapels, Deployment of demand response as a real-time resource in organized markets, Elec. J. (2008) 51-56, <https://doi.org/10.1016/j.tej.2008.05.011>.
- [17] H. Wang, S. Riaz, P. Mancarella, Integrated techno-economic modeling, flexibility analysis, and business case assessment of an urban virtual power plant with multi-market co-optimization, Appl. Energy 259 (2020) 114142, <https://doi.org/10.1016/j.apenergy.2019.114142>.
- [18] C. JJ, A. K, O. E, S. B, M. R, Expanding PV value: lessons learned from utility-led distributed energy resource aggregation in the United States, tech, in: Rep. NREL/TP-6A20-71984, National Renewable Energy Laboratory, Golden, CO, USA, November 2018. <https://www.nrel.gov/docs/fy19osti/71984.pdf>.
- [19] IRENA, Innovation landscape brief, Market Integra. Distri. Energy Resour. (2019). https://www.irena.org/-/media/Files/IRENA/Agency/Publication/2019/Feb/IRENA_Market_integration_distributed_system_2019.pdf?la=en&hash=%202A67D3A224F1443D529935DF471D5EA1E23C774A.
- [20] J. Migden-Ostrander, J. Shenot, C. Kadoch, M. Dupuy, C. Linvill, Enabling third-party Aggregation of distributed energy resources: report to the public service commission of Arkansas, Regulatory Assist. Project (February 2018). https://www.raponline.org/wp-content/uploads/2018/04/enabling_third_party_aggregation_distributed_energy_resources2.pdf.
- [21] GridLab, The role of distributed energy resources in today's grid transition. http://gridlab.org/wp-content/uploads/2019/04/GridLab_RoleORDER_online-1.pdf, August 2018.
- [22] Advanced Energy Economy, Putting distributed energy resources to work in wholesale electricity markets, in: Case Studies of Emerging Applications and Their Benefits for Customers and the Grid, September 2019. <https://info.aee.net/hubfs/Putting%20Distributed%20Energy%20Resources%20to%20Work%20in%20Wholesale%20Electricity%20Markets.pdf>.
- [23] EPRI, Realizing the Full Value of Central and Distributed Energy Resources, The Integrated Grid, 2014. <https://www.energy.gov/sites/prod/files/2015/03/f20/EPRI%20Integrated%20Grid021014.pdf>.
- [24] J. Gundlach, B. Unel, Getting the value of distributed energy resources right: using a societal value stack, New York university school of law Institute for policy integrity. https://policyintegrity.org/files/publications/Value_of_DER_Report.pdf, December 2019.
- [25] N. Mahmoudi, E. Heydarian-Forushani, M. Shafie-khah, T.K. Saha, M. Golshan, P. Siano, A bottom-up approach for demand response aggregators' participation in electricity markets., Elec. Power Syst. Res. 143 (2017) 121-129, <https://doi.org/10.1016/j.epr.2016.08.038>.
- [26] A.M. Carreiro, H.M. Jorge, C.H. Antunes, Energy management systems aggregators: a literature survey., Renew. Sustain. Energy Rev. 73 (2017) 1160-1172, <https://doi.org/10.1016/j.rser.2017.01.179>.
- [27] M. Obi, T. Slay, R. Bass, Distributed energy resource aggregation using customer-owned equipment: a review of literature and standards., Energy Rep. 6 (2020) 2358-2369, <https://doi.org/10.1016/j.egy.2020.08.035>.
- [28] J. Gundlach, R. Webb, Distributed energy resource participation in wholesale markets: lessons from the California ISO, Energy Law J. 39 (1) (2018). <http://columbiacrimelaw.com/files/2018/05/Gundlach-and-Webb-2018-05-DER-in-Wholesale-Markets.pdf>.
- [29] B.F. Hastings, Ten years of operating experience with a remote controlled water heater load management system at detroit edison, IEEE Transact. Power Appar. Syst. PAS 99 (4) (1980) 1437-1441, <https://doi.org/10.1109/TPAS.1980.319566>.
- [30] J.R. Stitt, Implementation of a large-scale direct load control system-some critical factors, IEEE Transact. Power Appar. Syst. 7 (1985) 1663-1669, <https://doi.org/10.1109/TPAS.1985.319196>.
- [31] A. Strindberg, M. Wärn, The Virtual Utility: Topics in Regulatory Economics and Policy Series, first ed., Springer, Boston, MA, USA, 1997 <https://doi.org/10.1007/978-1-4615-6167-5>.
- [32] D. P, S. Y, M. T, An Introduction to Grid Services: Concepts, Technical Requirements, and Provision from Wind, Tech. Rep. NREL/TP6A20-72578, National Renewable Energy Laboratory, Golden, CO, USA, January 2019. <https://www.nrel.gov/docs/fy19osti/72578.pdf>.
- [33] B. J. Kirby, Load response fundamentally matches power system reliability requirements, in: 2007 IEEE Power Engineering Society General Meeting, vol. 2007, pp. 1-6. doi:10.1109/PES.2007.386227.
- [34] R. Walawalkar, S. Fernands, N. Thakur, K.R. Cheeva, Evolution and current status of demand response (DR) in electricity markets: insights from PJM and NYISO, Energy 35 (4) (2010) 1553-1560, <https://doi.org/10.1016/j.energy.2009.09.017>. Demand Response Resources: the US and International Experience.
- [35] Y. Chen, J. Li, Comparison of security constrained economic dispatch formulations to incorporate reliability standards on demand response resources into Midwest ISO co-optimized energy and ancillary service market, Elec. Power Syst. Res. 81 (9) (2011) 1786-1795, <https://doi.org/10.1016/j.epr.2011.04.009>.
- [36] G. Sheble, G. Fahd, Unit commitment literature synopsis, IEEE Trans. Power Syst. 9 (1) (1994) 128-135, <https://doi.org/10.1109/59.317549>.
- [37] E. Boyd, Overview of power sector modeling. Depart. Energy, Office Energy Pol. Syst. Anal. https://www.energy.gov/sites/prod/files/2016/02/f29/EPSPowerSectorModeling_020416.pdf.
- [38] G. Steeger, L.A. Barroso, S. Rebennack, Optimal bidding strategies for hydro-electric producers: a literature survey, IEEE Trans. Power Syst. 29 (4) (2014) 1758-1766, <https://doi.org/10.1109/TPWRS.2013.2296400>.
- [39] N. Li, L. Chen, S.H. Low, Optimal demand response based on utility maximization in power networks, in: 2011 IEEE Power and Energy Society General Meeting, 2011, pp. 1-8, <https://doi.org/10.1109/PES.2011.6039082>.
- [40] I. Koutsopoulos, L. Tassiulas, Optimal control Policies for power demand scheduling in the smart grid, IEEE J. Sel. Area. Commun. 30 (6) (2012) 1049-1060, <https://doi.org/10.1109/JSAC.2012.120704>.

- [41] L. Gkatzikis, T. Salonidis, N. Hegde, L. Massoulié, Electricity markets meet the home through demand response, in: 2012 IEEE 51st IEEE Conference on Decision and Control (CDC), 2012, pp. 5846–5851, <https://doi.org/10.1109/CDC.2012.6426193>.
- [42] C. Calvillo, A. Sánchez-Miralles, J. Villar, F. Martín, Optimal planning and operation of aggregated distributed energy resources with market participation, *Appl. Energy* 182 (2016) 340–357, <https://doi.org/10.1016/j.apenergy.2016.08.117>.
- [43] G. Celli, F. Pilo, Optimal distributed generation allocation in MV distribution networks, in: PICA 2001. Innovative Computing for Power - Electric Energy Meets the Market. 22nd IEEE Power Engineering Society. International Conference on Power Industry Computer. Applications (Cat. No.01CH37195, 2001, pp. 81–86, <https://doi.org/10.1109/PICA.2001.932323>.
- [44] M. Lotfi, P.S. João Catalão, M.S. Javadi, A.E. Nezhad, M. Shafie-khah, Demand response program implementation for day-ahead power system operation, in: 2019 IEEE Milan PowerTech, 2019, pp. 1–6, <https://doi.org/10.1109/PTC.2019.8810850>.
- [45] P. Samadi, A.-H. Mohsenian-Rad, R. Schober, V.W.S. Wong, J. Jatskevich, Optimal real-time pricing algorithm based on utility maximization for smart grid, in: 2010 First IEEE International Conference on Smart Grid Communications, 2010, pp. 415–420, <https://doi.org/10.1109/SMARTGRID.2010.5622077>.
- [46] P. Samadi, R. Schober, V.W. Wong, Optimal energy consumption scheduling using mechanism design for the future smart grid, in: 2011 IEEE International Conference on Smart Grid Communications (SmartGridComm), 2011, pp. 369–374, <https://doi.org/10.1109/SmartGridComm.2011.6102349>.
- [47] A. Agnetis, G. Dellino, G. De Pascale, G. Innocenti, M. Pranzo, A. Vicino, Optimization models for consumer flexibility aggregation in smart grids: the ADDRESS approach, in: 2011 IEEE First International Workshop on Smart Grid Modeling and Simulation (SGMS), 2011, pp. 96–101, <https://doi.org/10.1109/SGMS.2011.6089206>.
- [48] N. Mahmoudi, T.K. Saha, M. Eghbal, A new demand response scheme for electricity retailers, *Elec. Power Syst. Res.* 108 (2014) 144–152, <https://doi.org/10.1016/j.epsr.2013.11.009>.
- [49] M. Houwing, G. Papaefthymiou, P.W. Heijnen, M.D. Ilic, Balancing wind power with virtual power plants of micro-CHPs, in: 2009 IEEE Bucharest PowerTech, 2009, pp. 1–7, <https://doi.org/10.1109/PTC.2009.5282056>.
- [50] E. Mashhour, S.M. Moghaddas-Tafreshi, Bidding strategy of virtual power plant for participating in energy and spinning reserve markets—Part I: problem formulation, *IEEE Trans. Power Syst.* 26 (2) (2011) 949–956, <https://doi.org/10.1109/TPWRS.2010.2070884>.
- [51] N. Mahmoudi, T.K. Saha, M. Eghbal, Modelling demand response aggregator behavior in wind power offering strategies, *Appl. Energy* 133 (2014) 347–355, <https://doi.org/10.1016/j.apenergy.2014.07.108>.
- [52] F. Martín-Martínez, A. Sánchez-Miralles, M. Rivier, Prosumers' optimal DER investments and DR usage for thermal and electrical loads in isolated microgrids, *Elec. Power Syst. Res.* 140 (2016) 473–484, <https://doi.org/10.1016/j.epsr.2016.05.028>.
- [53] F. Elghitani, W. Zhuang, Aggregating a large number of residential appliances for demand response applications, *IEEE Trans. Smart Grid* 9 (5) (2018) 5092–5100, <https://doi.org/10.1109/TSG.2017.2679702>.
- [54] P. Baran, On Distributed Communications: Introduction to Distributed Communications Networks [Online], RAND Corp., Santa Monica, CA, USA, 1964. RM-3420-PR, https://www.rand.org/content/dam/rand/pubs/research_memoranda/2006/RM3420.pdf.
- [55] L.G. Roberts, B.D. Wessler, Computer network development to achieve resource sharing, in: Proceedings of the Spring Joint Computer Conference, 1970, Jan, pp. 543–549, <https://doi.org/10.1145/1476936.1477020>.
- [56] J. Day, H. Zimmermann, The OSI reference model, *Proceedings of the IEEE* 71 (12) (1983) 1334–1340, <https://doi.org/10.1109/PROC.1983.12775>.
- [57] OpenADR Alliance, OpenADR 2.0 Profile Specification B Profile, 2012 0912–1, Online, 2015, <https://cimug.ucauiug.org/Projects/CIM-OpenADR/Shared Documents/Source Documents/OpenADR Alliance/OpenADR 2.0b Profile Specification v1.0.pdf>.
- [58] E. Koch, M. Piette, Architecture Concepts and Technical Issues for an Open, Interoperable Automated Demand Response Infrastructure, *Tech. Rep. LBNL-63664*, Ernest Orlando Lawrence Berkeley National Laboratory, Berkeley, CA, USA, 2007, Oct. <https://citeseerx.ist.psu.edu/viewdoc/download?doi=10.1.1.590.8222rep=rep1Ztype=pdf>.
- [59] U. Cali, O. Çakir, Energy policy instruments for distributed ledger technology empowered peer-to-peer local energy markets, *IEEE Access* 7 (2019) 82888–82900, <https://doi.org/10.1109/ACCESS.2019.2923906>.
- [60] U. Cali, A. Field, Towards the decentralized revolution in energy systems using blockchain technology, *Int. J. Smart Grid Clean Energy* 8 (3) (2019) 245–256, <https://doi.org/10.12720/sgce.8.3.245-256>.
- [61] A. Deshpande, K. Stewart, L. Lepetit, S. Gunasekar, Distributed ledger technologies/blockchain: challenges, opportunities and the prospects for standards [Online], in: British Standards Institute, 2017, https://www.bsigroup.com/LocalFiles/zh-tw/InfoSec-newsletter/No201706/download/BSI_Blockchain_in_DLT.
- [62] WeT. Aura, P. Nikander, J. Leiwo, DOS-resistant Authentication with Client Puzzles, in: B. Christianson, J.A. Malcolm, B. Crispo, M. Roebpfd (Eds.), *Security Protocols*, Springer Berlin Heidelberg, Berlin, Heidelberg, 2001, pp. 170–177.
- [63] A. de Vries, Bitcoin's energy consumption is underestimated: a market dynamics approach, *Energy Res. Soc. Sci.* 101721 (2020), <https://doi.org/10.1016/j.erss.2020.101721>.
- [64] U. Cali, M. Kuzlu, M. Pipattanasomporn, J. Kempf, L. Bai, *Digitalization of Power Markets and Systems Using Energy Informatics*, 2021.
- [65] Y. Wen, F. Lu, Y. Liu, X. Huang, Attacks and countermeasures on blockchains: a survey from layering perspective, *Comput. Network.* 191 (January) (2021), <https://doi.org/10.1016/j.comnet.2021.107978>, 0.1007/978-3-030-83301-5.
- [66] S. De Angelis, L. Aniello, R. Baldoni, F. Lombardi, A. Margheri, V. Sassone, PBFT vs proof-of-authority: applying the CAP theorem to permissioned blockchain, in: *CEUR Workshop Proceedings*, vol. 2058, 2018, pp. 1–11.
- [67] C. I. Dick, A. Praktikno, Blockchain Technology and Electricity Wholesale Markets: Expert Insights on Potentials and Challenges for OTC.
- [68] Trading in Europe, Online, in: A Handbook for Energy Market Basic. 10.3390/ens1205083, Staff Report (2020, vol. 2, FERC, Energy Primer, 2019. *Energies* 12 (5), https://www.ferc.gov/sites/default/files/2020-06/energy-primer-2020_Final.pdf.
- [69] European Commission, Quarterly report on European electricity markets, Online, in: First Quarter of 2021, European Commission, Directorate-General for Energy, Market Observatory for Energy, 2021, https://ec.europa.eu/energy/sites/default/files/quarterly_report_on_european_electricity_markets_q1_2021M_Merz_finaPotential_of_the_blockchain_technology_in_energy_Trading.pdf.
- [70] 2021M_Merz_finaPotential of the blockchain technology in energy Trading.pdf g, Online, in: Blockchain technology Introduction for business and IT managers.de Gruyter, 2016, https://www.ponton.de/downloads/mm/Potential-of-the-Blockchain-Technology-in-Energy-Trading_Merz.
- [71] 201CAISO 6en, Energy storage and distributed energy resources phasepdf 3, Online, in: ESDER 3 Issue Paper, 2017, <http://www.caiso.com/InitiativeDocuments/IssuePaper-EnergyStorageandDistributedEnergyResourcesPhase3.pdf>.
- [72] CAISO, Informational report of the California independent system operator [Online], https://www.caiso.com/Documents/Nov30_2016_InformationalReport_DistributedEnergyResourceProvider, 2016.
- [73] ER16–108EnelX, EnelX rises to the challenge of smart communities5.pdf s. <https://corporate.enelx.com/en/stories/2021/03/smart-communities-and-deggregation-project>. (Accessed 12 September 2021).
- [74] EnelX, Enel group completes purchase of industry leader EnerNOC. <https://www.enelx.com/n-a/en/press-releases/enel-group-completes-acquisition-of-leading-us-based->, 2017. (Accessed 12 September 2021).
- [75] provider-of-smart-energy-managementCPower, Distributed energy resources. <https://cpowerenergymanagement.com/distributed-energy-resources/>. (Accessed 12 September 2021).
- [76] CPower, CPower, sunnova to enter residential solar portfolio in ISO-NE forward capacity auction. <https://cpowerenergymanagement.com/who-we-are/newsandhappenings/cpower-sunnova-to-enter-residential->. (Accessed 12 September 2021).
- [77] NRG, Solar-portfolio-in-iso-ne-forward-capacity-auctionAsset-backed demand response. <https://www.nrg.com/business/all-products-and-services/asset-backed-demand-response.html>. (Accessed 12 September 2021).
- [78] Power Engineering, Nrg acquires energy curtailment specialists. <https://www.power-eng.com/news/nrg-acquires-energy-curtailment-specialists/>, 2013. (Accessed 12 September 2021).
- [79] IPKeys Power Partners, Integrated automated demand management. <https://ipkeyspowerpartners.com/solutions/iadm/>. (Accessed 12 September 2021).
- [80] IPKeys Power Partners, PKeys to provide energy demand response aggregation services – completes acquisition of North America power partners energy – consumers to benefit from proven OpenADR 2.0b technology. <https://ipkeyspowerpartners.com/uncategorized/ipkeys-to-provide-energy-demand-response-aggregationservices-completes-acquisition-of-north-america-power-partners-energy-consumers-to-benefit-from-proven->, 2018. (Accessed 12 September 2021).
- [81] Blueprint Power, openadr-2-0b-technologyOur services. <https://www.blueprintpower.com/services>. (Accessed 12 September 2021).
- [82] OhmConnect, Main landing page. <https://www.ohmconnect.com>. (Accessed 12 September 2021).
- [83] Swell Energy, Hi, we're swell energy. <https://www.swellenergy.com>. (Accessed 12 September 2021).
- [84] R. Heidorn, FERC OKs delay on order 2222 compliance, RTO insider, Online, <https://www.rtoinsider.com/articles/20274-ferc-grants-iso-ne-extension-on-order-2222-compliance>, 2021. (Accessed 14 August 2021).
- [85] J. York, FERC grants ISO-NE extension on order 2222 compliance, RTO insider, Online, <https://www.rtoinsider.com/articles/20274-ferc-grants-iso-ne-extension-on-order-2222-compliance>, 2021. (Accessed 14 August 2021).
- [86] OATI, What's happening with CAISO and NYISO? The latest on FERC 2222 filings. <https://www.oati.com/Blog/grid-modernization/ferc-2222-filings>. (Accessed 12 September 2021).
- [87] Enerchain, Enerchain – decentrally traded decentral energy. <https://enerchain.ponton.de>. (Accessed 12 September 2021).
- [88] NIST, Transactive energy: an overview. <https://www.nist.gov/engineering-laboratory/smart-grid/hot-topics/transactive-energy-overview>. (Accessed 5 September 2021).
- [89] P.D. Martini, L. Kristov, Distribution Systems in A High Distributed Energy Resources Future: Planning, Market Design, Operation and Oversight, *Tech. Rep. LBNL-1003797*, Ernest Orlando Lawrence Berkeley National Laboratory, Berkeley, CA, USA, October 2015. <https://emp.lbl.gov/publications/distribution-systems-high-distributed>.
- [90] S. Thomas, Evolution of the distribution system & the potential for distribution-level markets: a primer for state regulators, NARUC (2018). <https://pubs.naruc.org/pub/C0B3BA7C-0CBB-CB2A-E2B1-00A3756340BA>.
- [91] L. Kristov, Modernizing transmission-distribution interface coordination for a high-DER future, CAISO (2017). <https://energy.gov/sites/prod/files/2017/0>

- 4/f34/2.T-D%20Interface%20Panel%20-%20Lorenzo%20Kristov%2C%20C AISO.pdf. (Accessed 5 September 2021).
- [92] M. Khorasany, Y. Mishra, G. Ledwich, Market framework for local energy trading: a review of potential designs and market clearing approaches, *IET Gener., Transm. Distrib.* 12 (22) (2018), <https://doi.org/10.1049/iet-gtd.2018.5309>.
- [93] H. Yuan, F. Li, Y. Wei, Lmp step pattern detection based on real-time data, in: 2013 IEEE Power Energy Society General Meeting, vol. 2013, pp. 1–5. doi: 10.1109/PESMG.2013.6673058.
- [94] P. Sotkiewicz, J. Vignolo, Nodal Pricing for Distribution Networks: Efficient Pricing for Efficiency Enhancing DG, vol. 21, *IEEE Transactions on Power Systems*, 2006, pp. 1013–1014, <https://doi.org/10.1109/TPWRS.2006.873006>, 2.
- [95] K. Shaloudegi, N. Madinehi, S.H. Hosseini, H.A. Abyaneh, A novel policy for locational marginal price calculation in distribution systems based on loss reduction allocation using game theory, *IEEE Trans. Power Syst.* 27 (2) (2012) 811–820, <https://doi.org/10.1109/TPWRS.2011.2175254>.
- [96] F. Sahriatzadeh, P. Nirbhavane, A.K. Srivastava, Locational marginal price for distribution system considering demand response, in: 2012 North American Power Symposium (NAPS), 2012, pp. 1–5.
- [97] R. Li, Q. Wu, S.S. Oren, Distribution locational marginal pricing for optimal electric vehicle charging management, *IEEE Trans. Power Syst.* 29 (1) (2014) 203–211, <https://doi.org/10.1109/TPWRS.2013.2278952>.
- [98] R. Christie, B. Wollenberg, I. Wangensteen, Transmission management in the deregulated environment, in: Proceedings of the IEEE, vol. 88, 2000, pp. 170–195, <https://doi.org/10.1109/5.823997>, 2.
- [99] OATI, Nerc interchange distribution calculator (idc) - a 10-year success story. <https://www.prweb.com/releases/nerc/idc/prweb2981784.htm>, 2009. (Accessed 8 September 2021).
- [100] M. Cain, R. O'Neill, A. Castillo, History of optimal power flow and formulations: optimal power flow paper 1, FERC Staff Paper (2012). <https://www.ferc.gov/sites/default/files/2020-05/acopf-1-history-formulation-testing.pdf>.
- [101] F. Li, R. Bo, Dcopf-based lmp simulation: algorithm, comparison with acopf, and sensitivity, *IEEE Trans. Power Syst.* 22 (4) (2007) 1475–1485, <https://doi.org/10.1109/TPWRS.2007.907924>.
- [102] N. Rahbari-Asr, U. Ojha, Z. Zhang, M.-Y. Chow, Incremental welfare consensus algorithm for cooperative distributed generation/demand response in smart grid, *IEEE Trans. Smart Grid* 5 (6) (2014) 2836–2845, <https://doi.org/10.1109/TSG.2014.2346511>.
- [103] Y. Cai, J. Lin, C. Wan, Y. Song, A bi-level trading model for an active distribution company considering demand response exchange, in: 2016 IEEE PES Asia-Pacific Power and Energy Engineering Conference (APPEEC), 2016, pp. 64–68, <https://doi.org/10.1109/APPEEC.2016.7779471>.
- [104] D. Wu, T. Yang, A.A. Stoorvogel, J. Stoustrup, Distributed optimal coordination for distributed energy resources in power systems, *IEEE Trans. Autom. Sci. Eng.* 14 (2) (2017) 414–424, <https://doi.org/10.1109/TASE.2016.2627006>.
- [105] H. Pourbabak, J. Luo, T. Chen, W. Su, A novel consensus-based distributed algorithm for economic dispatch based on local estimation of power mismatch, *IEEE Trans. Smart Grid* 9 (6) (2018) 5930–5942, <https://doi.org/10.1109/TSG.2017.2699084>.
- [106] W. Tushar, C. Yuen, H. Mohsenian-Rad, T. Saha, H.V. Poor, K.L. Wood, Transforming energy networks via peer-to-peer energy trading: the potential of game-theoretic approaches, *IEEE Signal Process. Mag.* 35 (4) (2018) 90–111, <https://doi.org/10.1109/MSP.2018.2818327>.
- [107] M.H. Cintuglu, H. Martin, O.A. Mohammed, Real-time implementation of multiagent-based game theory reverse auction model for microgrid market operation, *IEEE Trans. Smart Grid* 6 (2) (2015) 1064–1072, <https://doi.org/10.1109/TSG.2014.2387215>.
- [108] W. Lee, L. Xiang, R. Schober, V.W.S. Wong, Direct electricity trading in smart grid: a coalitional game analysis, *IEEE J. Sel. Area. Commun.* 32 (7) (2014) 1398–1411, <https://doi.org/10.1109/JSAC.2014.2332112>.
- [109] W. Tushar, B. Chai, C. Yuen, S. Huang, D.B. Smith, H.V. Poor, Z. Yang, Energy storage sharing in smart grid: a modified auction-based approach, *IEEE Trans. Smart Grid* 7 (3) (2016) 1462–1475, <https://doi.org/10.1109/TSG.2015.2512267>.
- [110] Y. Cai, T. Huang, E. Bompard, Y. Cao, Y. Li, Self-sustainable community of electricity prosumers in the emerging distribution system, *IEEE Trans. Smart Grid* 8 (5) (2017) 2207–2216, <https://doi.org/10.1109/TSG.2016.2518241>.
- [111] H.S.V.S.K. Nunna, D. Srinivasan, Multiagent-based transactive energy framework for distribution systems with smart microgrids, *IEEE Trans. Ind. Inf.* 13 (5) (2017) 2241–2250, <https://doi.org/10.1109/TII.2017.2679808>.
- [112] F. Meng, D. Haughton, B. Chowdhury, M.L. Crow, G.T. Heydt, Distributed generation and storage optimal control with state estimation, *IEEE Trans. Smart Grid* 4 (4) (2013) 2266–2273, <https://doi.org/10.1109/TSG.2013.2266328>.
- [113] S. Hanif, K. Zhang, C.M. Hackl, M. Barati, H.B. Gooi, T. Hamacher, Decomposition and equilibrium achieving distribution locational marginal prices using trust-region method, *IEEE Trans. Smart Grid* 10 (3) (2019) 3269–3281, <https://doi.org/10.1109/TSG.2018.2822766>.
- [114] J. Stekli, L. Bai, U. Cali, Pricing for reactive power and ancillary services in distribution electricity markets, in: 2021 IEEE Power Energy Society Innovative Smart Grid Technologies Conference (ISGT), 2021, pp. 1–5, <https://doi.org/10.1109/ISGT49243.2021.9372202>.
- [115] S. Zhang, J.-H. Lee, Analysis of the main consensus protocols of blockchain, *ICT Express* 6 (2) (2020) 93–97, <https://doi.org/10.1016/j.ict.2019.08.001>.
- [116] M. Kuzlu, S. Sarp, M. Pipattanasomporn, U. Cali, Realizing the potential of blockchain technology in smart grid applications, in: 2020 IEEE Power Energy Society Innovative Smart Grid Technologies Conference (ISGT), 2020, pp. 1–5, <https://doi.org/10.1109/ISGT45199.2020.9087677>.
- [117] I. Petri, M. Barati, Y. Rezgui, O.F. Rana, Blockchain for energy sharing and trading in distributed prosumer communities, *Comput. Ind.* 123 (2020) 103282, <https://doi.org/10.1016/j.compind.2020.103282>.
- [118] Q. Wang, M. Su, Integrating blockchain technology into the energy sector — from theory of blockchain to research and application of energy blockchain, *Comput. Sci. Rev.* 37 (2020) 100275, <https://doi.org/10.1016/j.cosrev.2020.100275>.
- [119] N. Wang, J. Li, S.-S. Ho, C. Qiu, Distributed machine learning for energy trading in electric distribution system of the future, *Electr. J.* 34 (1) (2021) 106883, <https://doi.org/10.1016/j.ej.2020.106883>.
- [120] I. Antonopoulos, V. Robu, B. Couraud, D. Kirli, S. Norbu, A. Kiprakis, D. Flynn, S. Elizondo-Gonzalez, S. Wattam, Artificial intelligence and machine learning approaches to energy demand-side response: a systematic review, *Renew. Sustain. Energy Rev.* 130 (2020) 109899, <https://doi.org/10.1016/j.rser.2020.109899>.
- [121] M.S. Ibrahim, W. Dong, Q. Yang, Machine learning driven smart electric power systems: current trends and new perspectives, *Appl. Energy* 272 (2020) 115237, <https://doi.org/10.1016/j.apenergy.2020.115237>.
- [122] M. Farhoumandi, Q. Zhou, M. Shahidepour, A review of machine learning applications in iot-integrated modern power systems, *Electr. J.* 34 (1) (2021) 106879, <https://doi.org/10.1016/j.ej.2020.106879>, special Issue: Machine Learning Applications To Power System Planning And Operation.
- [123] E.A. Soto, L.B. Bosman, E. Wollega, W.D. Leon-Salas, Peer-to-peer energy trading: a review of the literature, *Appl. Energy* 283 (2021) 116268, <https://doi.org/10.1016/j.apenergy.2020.116268>.
- [124] J. Kang, R. Yu, X. Huang, S. Maharjan, Y. Zhang, E. Hossain, Enabling localized peer-to-peer electricity trading among plug-in hybrid electric vehicles using consortium blockchains, *IEEE Trans. Ind. Inf.* 13 (6) (2017) 3154–3164, <https://doi.org/10.1109/TII.2017.2709784>.
- [125] M.L. Di Silvestre, P. Gallo, M.G. Ippolito, E.R. Sanseverino, G. Zizzo, A technical approach to the energy blockchain in microgrids, *IEEE Trans. Ind. Inf.* 14 (11) (2018) 4792–4803, <https://doi.org/10.1109/TII.2018.2806357>.
- [126] N.Z. Aitzhan, D. Svetinovic, Security and privacy in decentralized energy trading through multi-signatures, blockchain and anonymous messaging streams, *IEEE Trans. Dependable Secure Comput.* 15 (5) (2018) 840–852, <https://doi.org/10.1109/TDSC.2016.2616861>.
- [127] E. Mengelkamp, B. Notheisen, C. Beer, D. Dauer, C. Weinhardt, A blockchain-based smart grid: towards sustainable local energy markets, *Comput. Sci. Res. Dev.* 33 (2018) 207–214, <https://doi.org/10.1007/s00450-017-0360-9>.
- [128] M. Sabounchi, J. Wei, Towards resilient networked microgrids: blockchain-enabled peer-to-peer electricity trading mechanism, in: 2017 IEEE Conference on Energy Internet and Energy System Integration (EI2), 2017, pp. 1–5, <https://doi.org/10.1109/EI2.2017.8245449>.
- [129] Z. Li, J. Kang, R. Yu, D. Ye, Q. Deng, Y. Zhang, Consortium blockchain for secure energy trading in industrial internet of things, *IEEE Trans. Ind. Inf.* 14 (8) (2018) 3690–3700, <https://doi.org/10.1109/TII.2017.2786307>.
- [130] sonnen, What is the sonnenCommunity. <https://sonnengroup.com/sonnencommunity/>. (Accessed 13 September 2021).
- [131] E. Bullich-Massagué, M. Aragiés-Peñalba, P. Olivella-Rosell, P. Lloret-Gallego, J.-A. Vidal-Clos, A. Sumper, Architecture definition and operation testing of local electricity markets. the empower project, in: 2017 International Conference on Modern Power Systems (MPS), vol. 2017, pp. 1–5. doi:10.1109/MPS.2017.7974447.
- [132] Empower, EMPPOWER started a new pilot project, Accessed September 13, 2021 (2020). <https://www.interregeurope.eu/empower/news/news-article/8502/empower-started-a-new-pilot-project/>.
- [133] M. Mihaylov, S. Jurado, N. Avellana, K. Van Moffaert, I. M. de Abrid, A. Nowé, Nrgcoin: virtual currency for trading of renewable energy in smart grids, in: 11th International Conference on the European Energy Market (EEM14), vol. 2014, pp. 1–6. doi:10.1109/EEM.2014.6861213.
- [134] NRGCoin, NRGCoin demonstration platform. <https://nrgcoin.org/demonstration/>. (Accessed 13 September 2021).
- [135] P2P-SmarTest, P2P-SmarTest landing page. <https://www.p2psmartest-h2020.eu>. (Accessed 13 September 2021).
- [136] LO3 Energy, Local energy solutions. <https://lo3energy.com>. (Accessed 13 September 2021).
- [137] Hive Power, Grids, made smart. <https://hivepower.tech>.
- [138] Powerledger, The power behind new energy. <https://www.powerledger.io>. (Accessed 4 November 2021).