

Kari Thorset Lervik  
Anja Myhre Waitz

# Techno-Economic Analysis of Rural Microgrid at Eco Moyo Education Centre in Kenya

Master's thesis in Energy and Environmental Engineering

Supervisor: Steve Völler

Co-supervisor: Ida Fuchs

June 2022



Kari Thorset Lervik  
Anja Myhre Waitz

# **Techno-Economic Analysis of Rural Microgrid at Eco Moyo Education Centre in Kenya**

Master's thesis in Energy and Environmental Engineering  
Supervisor: Steve Völler  
Co-supervisor: Ida Fuchs  
June 2022

Norwegian University of Science and Technology  
Faculty of Information Technology and Electrical Engineering  
Department of Electric Power Engineering



---

## Preface

This master thesis is the conclusion of our Master of Science (MSc) in Energy and Environmental Engineering at the Department of Electric Power Engineering at the Norwegian University of Science and Technology (NTNU). The thesis is written for Engineers Without Borders (EWB) Norway, and thesis addresses the development of a microgrid at Eco Moyo Education Centre in Kenya.

We would like to thank our supervisor Steve Völler for great guidance throughout the semester. We are also grateful for the help from our co-supervisor Ida Fuchs, especially in regards to the establishment of load profiles. We also want to express gratitude to the founder of Eco Moyo, Lindsay Sanner, for good conversations and help in obtaining data about the school and its users. We are thankful for the contribution from Johannes Lervik for making the 3D visualizations of the school used in the thesis. We would also like to thank the staff and pupils at Eco Moyo for giving us insight into their life and user habits. Thank you to Engineers Without Borders for giving us this amazing opportunity of writing a Master With Meaning (MmM).

Finally, we would like to express gratitude towards our family and friends for all support.

Trondheim, June 2022



Kari Thorset Lervik

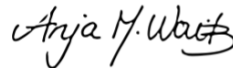

Anja Myhre Waitz

---

## Abstract

This master thesis is a Master with Meaning (MmM) written on behalf of Engineers Without Borders (EWB) Norway in the Spring 2022. The thesis addresses the electricity supply at the primary school Eco Moyo Education Centre in Kenya. The school needs reliable electricity supply, and it is desirable to use renewable energy sources for the electricity production. The purpose of the master thesis is therefore to propose a system design for a microgrid supplying electricity to the school from renewable energy sources. Off-grid solutions supplied by PV panels and batteries are the main focuses.

As a part of the master thesis, fieldwork at the school was conducted in March 2022. The main purpose of the fieldwork was data collection about the electricity demand and buildings at the property. The fieldwork was important for understanding the possibilities and limitations for future systems for electricity supply at the school, and thus to set the project boundaries for the master thesis.

The bottom-up stochastic model Remote-Areas Multi-Energy Systems Load Profiles (RAMP) is used to establish minute based annual load profiles for the school. This modelling tool is chosen based on its high performance, as well as due to the inaccuracy related to data collected from user surveys and interviews. RAMP model input are constructed for each building at the property, and both seasonal and weekly variations are accounted for. The load profiles should account for future developments at the property, and hence the buildings that are expected to be built in the next few years is also included in the model input.

The buildings at the school is currently organized in clusters. Based on preferences defined by Eco Moyo, as well as experiences from the fieldwork, system solutions with separate systems for each cluster is evaluated, referred to as a clustered solution. This clustered solution is compared with a system solution where the whole property is supplied by one system, referred to as a non-clustered solution. Load profiles are therefore constructed in RAMP for each individual cluster, as well as for the non-clustered solution.

To obtain the proposed system solutions simulations are conducted in PVsyst. The proposed system topology is an off-grid AC coupled microgrid supplied by PV panels and lithium-ion batteries. Load profiles are used as input to the off-grid PVsyst simulations for each cluster and the non-clustered solution. System solutions are decided based on the simulation results in PVsyst. Investment costs, autonomy, and load coverage are considered important parameters when determining these system solutions. Other project specific considerations are also used for the decision making of the final system solution proposal. For comparative purposes back-up solution evaluations with diesel generators and grid-connection are also performed.

It is concluded that both system solutions for clustered and non-clustered solutions offer high performances, and acceptable investment costs. However, a clustered solution allows for gradual expansions in accordance with available funding, when building projects are realized, and when more electricity supply is needed at the school. Due to this main advantage, as well as other advantages, the clustered solution is found to provide the optimized system solution for electricity supply at Eco Moyo Education Centre.

---

## Sammendrag

Denne masteroppgaven er en Master med Mening (MmM) skrevet for Ingeniører Uten Grenser (IUG) Norge våren 2022. Oppgaven tar for seg strømforsyningen ved grunnskolen Eco Moyo Education Centre i Kenya. Skolen har behov for en pålitelig strømforsyning, og det er ønskelig å bruke fornybare energikilder til strømproduksjonen. Formålet med oppgaven er derfor å foreslå et systemdesign for et mikronett som leverer elektrisitet til skolen fra fornybare energikilder. “Off-grid” løsninger med PV paneler og batterier er hovedfokuset for oppgaven.

Som en del av masteroppgaven ble det utført feltarbeid på skolen i mars 2022. Hovedformålet med feltarbeidet var datainnsamling om strømbehovet og bygningene på eiendommen. Feltarbeidet var viktig for å forstå muligheter og begrensninger for fremtidige system for strømforsyning ved skolen, og dermed for å sette prosjektgrensene for masteroppgaven.

Den stokastiske modellen “Remote-Areas Multi-Energy Systems Load Profiles (RAMP)” brukes til å etablere minuttbaserte årlige lastprofiler for skolen. Dette modelleringsverktøyet er valgt basert på dets høye ytelse, samt på grunn unøyaktigheten knyttet til data samlet inn fra brukerundersøkelser og intervjuer. Modellinnmating til RAMP konstrueres for hvert bygg på eiendommen, og det tas hensyn til både sesong- og ukesvariasjoner. Lastprofilene bør ta hensyn til fremtidig utvikling av tomten, og bygninger som forventes å bli bygget innen de neste få årene er derfor også inkludert i modellinnmatingen.

Bygningene på skolen er i dag organisert i klynger. Basert på preferanser definert av Eco Moyo, samt erfaringer fra feltarbeidet, evalueres systemløsninger med separate systemer for hver klynge, omtalt som en klynge-løsning. Denne klynge-løsningen sammenlignes med en systemløsning hvor hele eiendommen forsynes av ett system, referert til som en ikke-klynget løsning. Lastprofiler konstrueres derfor i RAMP for hver klynge så vel som for den ikke-klyngede løsningen.

For å oppnå de foreslåtte systemløsningene gjennomføres simuleringer i PVsyst. Den foreslåtte systemtopologien er et off-grid AC mikronett med PV paneler og litium-ion batterier. De aggregerte lastprofilene brukes som input til off-grid PVsyst simuleringer for hver klynge og for den ikke-klyngede løsningen. Systemløsninger bestemmes basert på simuleringsresultatene i PVsyst. Investeringskostnader, autonomi og lastdekning anses som viktige parametere når disse systemløsningene skal bestemmes. Andre prosjektspesifikke hensyn brukes også for beslutningstaking av det endelige systemforslaget. For sammenlignende formål er det også utført evalueringer av backupløsninger med dieselgeneratorer og nettilkobling.

Det konkluderes med at systemløsninger for klyngede og ikke-klyngede løsninger gir høy ytelse, og akseptable investeringskostnader. En klynget løsning åpner midlertid for gradvise utvidelser i takt med når midler mottas, når byggeprosjekter realiseres, og når det er behov for mer strømforsyning på skolen. På grunn av denne hovedfordelen, samt andre fordeler, er det funnet at den klyngede løsningen gir den optimaliserte systemløsningen for strømforsyning ved Eco Moyo Education Centre.

---

# Table of Contents

<b>List of Figures</b>	<b>ix</b>
<b>List of Tables</b>	<b>xi</b>
<b>1 Introduction</b>	<b>3</b>
1.1 Motivation . . . . .	3
1.2 Objective . . . . .	4
1.3 Background . . . . .	5
1.3.1 Eco Moyo Education Centre . . . . .	5
1.3.2 Strategic plan . . . . .	8
1.4 Project boundaries . . . . .	8
1.4.1 Current electricity supply . . . . .	8
1.4.2 Preliminary project . . . . .	8
1.4.3 Off-grid solution . . . . .	8
1.4.4 Preferences of end-users at the school . . . . .	9
1.4.5 Limitations of the local company . . . . .	9
1.4.6 Environmental considerations . . . . .	9
1.4.7 Future expansions of the property . . . . .	9
1.4.8 Clusters . . . . .	9
1.4.9 Aspects that will not be considered . . . . .	9
<b>2 Recommendations from the preliminary project</b>	<b>11</b>
<b>3 Theoretical background</b>	<b>12</b>
3.1 Kenya . . . . .	12
3.1.1 Electricity access . . . . .	12
3.1.2 Climate in Kilifi . . . . .	13
3.2 Solar energy and PV technology . . . . .	15
3.2.1 Solar resource . . . . .	16
3.2.2 The PV effect and PV cells . . . . .	16
3.2.3 Main PV components . . . . .	16
3.2.4 Maximized production and loss reduction . . . . .	17
3.3 Microgrids . . . . .	18
3.3.1 The distribution system . . . . .	18
3.3.2 Batteries . . . . .	19



---

3.3.3	Converters . . . . .	22
3.3.4	AC microgrids . . . . .	23
3.3.5	DC microgrids . . . . .	23
3.3.6	Hybrid AC and DC microgrids . . . . .	24
3.3.7	Off-grid microgrids . . . . .	25
3.3.8	Grid connected microgrids . . . . .	26
3.4	Load profiles . . . . .	27
3.4.1	Peak and average load . . . . .	27
3.4.2	Energy consumption . . . . .	27
3.4.3	Bottom-up load profile construction . . . . .	28
3.5	Economy . . . . .	30
3.5.1	Levelized cost of energy . . . . .	30
3.6	Presentation of external modelling tools . . . . .	30
3.6.1	Remote-Areas Multi-Energy Systems Load Profiles . . . . .	30
3.6.2	PVsystem . . . . .	32
<b>4</b>	<b>Fieldwork</b>	<b>33</b>
4.1	Data collection . . . . .	33
4.1.1	Annual school schedule and vacations . . . . .	33
4.1.2	Observations of the property . . . . .	34
4.1.3	Local main grid . . . . .	35
4.2	Other experiences and considerations . . . . .	36
4.3	Installation of PV systems . . . . .	37
4.3.1	The local company . . . . .	37
4.3.2	New system . . . . .	37
4.3.3	Old system . . . . .	38
<b>5</b>	<b>Presentation of the property</b>	<b>40</b>
5.1	Overview of property . . . . .	40
5.2	Kitchen area . . . . .	40
5.3	Student area . . . . .	42
5.4	Director's housing area . . . . .	43
5.5	Teacher's area . . . . .	43
5.6	Security building . . . . .	44
5.7	Visitor area . . . . .	45
5.8	Classroom area . . . . .	46

---

---

5.9	The Leap Learning Lab . . . . .	48
5.10	Possible future expansions . . . . .	49
5.10.1	Computer lab . . . . .	49
5.10.2	Expanded visitor area . . . . .	50
5.10.3	Multi-purpose building . . . . .	50
5.10.4	Workshop . . . . .	50
<b>6</b>	<b>Establishing load profiles in RAMP</b>	<b>52</b>
6.1	RAMP model input . . . . .	52
6.1.1	Accounting for seasonal variations . . . . .	52
6.1.2	Appliances . . . . .	53
6.1.3	Adjustments made to account for varying temperatures . . . . .	55
6.2	Load modelling . . . . .	55
6.2.1	Current visitor area . . . . .	55
6.2.2	Kitchen area . . . . .	57
6.2.3	Teacher's area . . . . .	59
6.2.4	Classroom area . . . . .	61
6.2.5	Director's housing area . . . . .	63
6.2.6	Student dorm area . . . . .	65
6.3	Future building projects . . . . .	66
6.3.1	The Computer Lab . . . . .	66
6.3.2	Expanded visitor area . . . . .	67
6.3.3	Multi-purpose building . . . . .	69
6.3.4	Workshop . . . . .	70
6.4	Daily load profile of the whole property . . . . .	72
<b>7</b>	<b>System simulation in PVsyst</b>	<b>74</b>
7.1	System topology . . . . .	74
7.2	Cluster based approach . . . . .	76
7.2.1	Clusters and simulation cases . . . . .	77
7.2.2	Load profiles for the solutions . . . . .	78
7.3	Simulation variables . . . . .	79
7.4	Model input . . . . .	81
7.4.1	Site and weather data . . . . .	81
7.4.2	System components . . . . .	82
7.5	Off-grid system simulations . . . . .	85

---

---

7.5.1	Cluster 1 simulations . . . . .	85
7.5.2	Cluster 2 simulations . . . . .	87
7.5.3	Cluster 3 simulations . . . . .	89
7.5.4	Cluster 4 simulations . . . . .	90
7.5.5	Cluster 5 simulations . . . . .	93
7.5.6	Cluster 6 simulations . . . . .	94
7.5.7	Non-clustered simulations . . . . .	96
7.6	Backup evaluation: grid connection . . . . .	98
7.6.1	Results for grid connection as backup . . . . .	100
7.7	Backup evaluation: off-grid with diesel generator . . . . .	101
7.7.1	Additional model input for backup simulations in PVsyst . . . . .	101
7.7.2	Results for diesel generator backup . . . . .	102
<b>8</b>	<b>Results</b>	<b>103</b>
8.1	Economic results . . . . .	103
8.2	Performance results . . . . .	104
8.2.1	Unmet demand . . . . .	104
8.2.2	Excess energy . . . . .	105
8.2.3	Autonomy . . . . .	105
8.3	Component results . . . . .	106
8.4	Summary of system solutions . . . . .	107
<b>9</b>	<b>Discussion</b>	<b>108</b>
9.1	Result discussion . . . . .	108
9.1.1	Non-clustered with 2.7 days autonomy . . . . .	108
9.1.2	Non-clustered with 2.0 days autonomy . . . . .	108
9.1.3	Clustered . . . . .	108
9.2	Further evaluations . . . . .	109
9.2.1	Gradual expansions and electricity demands . . . . .	109
9.2.2	Social aspects . . . . .	110
9.2.3	Plausibility . . . . .	110
9.3	Grid connection . . . . .	111
9.3.1	Current system . . . . .	111
9.3.2	Non-clustered solution . . . . .	112
9.4	Backup diesel generator . . . . .	112
9.5	Other considerations . . . . .	112

---

9.5.1	Safety and maintenance . . . . .	113
9.5.2	Communication and knowledge-sharing . . . . .	113
9.6	Uncertainty analysis . . . . .	113
9.6.1	Load profiles . . . . .	113
9.6.2	Utilizing external modelling tools . . . . .	116
9.6.3	System topology . . . . .	116
9.6.4	Additional losses . . . . .	117
9.6.5	Component selection . . . . .	117
9.6.6	Component prices . . . . .	119
9.6.7	Weather data . . . . .	120
9.6.8	Grid connection . . . . .	120
9.6.9	Backup generator . . . . .	121
<b>10</b>	<b>Conclusion</b>	<b>122</b>
<b>11</b>	<b>Further work</b>	<b>124</b>
	<b>Bibliography</b>	<b>125</b>
	<b>Appendix</b>	<b>130</b>
A	Data sheets . . . . .	130
A.1	Solar Tubular Gel Battery 150Ah to 200Ah . . . . .	130
A.2	Growatt PV Off-grid Inverter 3.5 kW . . . . .	133
A.3	GCL M8/72H Monocrystalline Module . . . . .	134
B	Model input to RAMP . . . . .	136
B.1	Power ratings of appliances . . . . .	136
B.2	Current visitor area . . . . .	136
B.3	Teacher's area . . . . .	137
B.4	Classroom area . . . . .	139
B.5	Student dorm area . . . . .	140
B.6	Director's housing area . . . . .	140
B.7	Kitchen area . . . . .	141
B.8	Security building . . . . .	141
B.9	Future expansions . . . . .	142

---

## List of Figures

2	Illustration of the work progress in the master thesis. . . . .	5
3	Eco Moyo map placement. . . . .	6
4	Existing clusters at the property. . . . .	7
5	Drone picture of parts of the property. . . . .	7
6	Electricity generation by source in Kenya 2019 . . . . .	13
7	Average monthly rainfall in Kilifi. . . . .	14
8	Average daily solar irradiation extracted from Meteonorm. . . . .	14
9	Average monthly temperatures extracted from Meteonorm. . . . .	15
10	PV tilt angle and azimuth. . . . .	17
11	System topology for a DC microgrid with DC load. . . . .	24
12	System topology for a hybrid AC and DC system. . . . .	24
13	Solar Home System. . . . .	25
14	Illustration of a microgrid with a diesel generator as a backup power supply . . . .	26
15	Top-down and bottom-up procedures to establish load profiles. . . . .	29
16	The modelling layers in RAMP. . . . .	31
17	The transformer closest to Eco Moyo Education Centre (Eco Moyo) and the local grid with three phase wires. . . . .	36
18	PV panels of the new PV system installed on the roof of Class 5. . . . .	38
19	System at kitchen. . . . .	39
20	Overview of property. . . . .	40
21	Outside of kitchen. . . . .	41
22	Inside of kitchen. . . . .	41
23	Area outside of the girl dorm. . . . .	42
24	Inside girl showers. . . . .	42
25	Outside directors house. . . . .	43
26	Outside Staff Court. . . . .	44
27	Outside Staff Room. . . . .	44
28	Side views of security building. . . . .	45
29	Overview of visitor area. . . . .	46
30	Outside and inside sleeping area main hut. . . . .	46
31	Outside class 1. . . . .	47
32	Class 5. . . . .	47
33	Inside class 5. . . . .	48
34	Outside Leap Learning Lab. . . . .	48

---

35	Inside Leap Learning Lab. . . . .	49
36	Methodology to obtain the load profiles of the property. . . . .	52
37	Daily minute based load profiles for VH1 with varying visitor activity during a warm season. . . . .	57
38	Daily minute based load profiles for the kitchen with varying visitor activity during a warm season. . . . .	59
39	Daily minute based load profiles for SR during different seasons. . . . .	61
40	Daily minute based load profiles for the LLL during the different seasons. . . . .	63
41	Daily minute based load profiles for the Director's housing area during different seasons. . . . .	65
42	Daily minute based load profiles for the student dorm area with varying temperatures. . . . .	66
43	Daily minute based load profile for the CL during a normal school week in the hot season. . . . .	67
44	Daily minute based load profiles for the expanded visitor area with varying visitor activity during a warm season. . . . .	69
45	Daily minute based load profiles for the MPB during different periods of the year. . . . .	70
46	Daily minute based load profiles for the WS when different appliance usage is reflected. . . . .	72
47	Weekly minute based load profile for the workshop during a regular school week in the hot season. . . . .	72
48	Daily minute based load profile of the whole property during the hot season. . . . .	73
49	Methodology to obtain the system designs from PVsyst. . . . .	74
50	System topology used as basis for off-grid system simulations in PVsyst. . . . .	75
51	Cluster 1 (green), Cluster 2 (red), Cluster 3 (blue), Cluster 4 (pink), Cluster 5 (orange), and Cluster 6 (yellow). . . . .	78
52	Sensitivity analysis of days of autonomy and related investment cost in kNOK. . . . .	80
53	Sensitivity analysis PV panel capacity. . . . .	83
54	Sensitivity analysis battery pack voltage level. . . . .	85
55	Cluster 1 in green with PV panels on kitchen. . . . .	86
56	Annual minute based load profile for Cluster 1. . . . .	86
57	Simulation results for different system solutions in Cluster 1. . . . .	87
58	Cluster 2 in red with PV panel on directors house. . . . .	87
59	Annual minute based load profile for Cluster 2. . . . .	88
60	Simulation results for different system solutions in Cluster 2. . . . .	88
61	Cluster 3 in blue with PV panels. . . . .	89
62	Annual minute based load profile for Cluster 3. . . . .	89
63	Simulation results for different system solutions in Cluster 3. . . . .	90
64	Cluster 4 in pink with PV panels on Class 5. . . . .	91
65	Annual minute based load profile for initial cluster for Cluster 3. . . . .	91

---

---

66	Simulation results for different system solutions in Cluster 4. . . . .	92
67	Cluster 5 in orange with PV panels on the Computer Lab. . . . .	93
68	Annual minute based load profile for Cluster 5. . . . .	93
69	Simulation results for different system solutions in Cluster 5. . . . .	94
70	Cluster 6 in yellow with PV panels on multi-purpose building. . . . .	95
71	Annual minute based load profile for Cluster 6. . . . .	95
72	Simulation results for different system solutions in Cluster 6. . . . .	96
73	Annual minute based load profile of the non-clustered solution. . . . .	97
74	Autonomy results for different system configurations in non-clustered solution. . .	97
75	Unmet demand for different system solutions in Non-clustered solution. . . . .	98
76	System topology for grid connected system. . . . .	99
77	System topology for off-grid system with diesel generator. . . . .	101
78	Results from diesel generator backup solution. . . . .	102
79	Overview of clusters with PV panel placements. . . . .	103
80	Resulting investment costs for all system solutions. . . . .	103
81	Results for unmet demand for all system solutions. . . . .	104
82	Results for excess energy for all system solutions. . . . .	105
83	The autonomy of all clusters and non-clustered solutions. . . . .	106
84	Results for required PV panels and batteries for all system solutions. . . . .	106
85	Sensitivity analysis of optimal azimuth and plane tilt. . . . .	118
86	Illustration of final system solution proposal. . . . .	123

## List of Tables

1	Input data required by RAMP-model. . . . .	31
2	Typical annual school schedule for Eco Moyo. . . . .	33
3	Components installed during fieldwork. . . . .	37
4	Prices for components and installation of installed PV system. . . . .	38
5	Temperature intervals established for the seasons defined by average monthly temperatures. . . . .	53
6	The time periods the model input is adjusted to in order to establish annual load profiles. . . . .	53
7	Appliance parameters that are independent of the building type they are related to. .	54
8	The parameters that are specific to the appliance in each building type. . . . .	54
9	Appliances assumed at the property. . . . .	54
10	Seasonal based duty cycles for fridge. . . . .	55

---

11	Building types for the current visitor area. . . . .	56
12	Appliances assumed in the visitor area. . . . .	56
13	Appliances assumed in the Visitor hut type 1 during the hot season with high visitor activity. . . . .	57
14	Building types at the kitchen area, and the number of Users, i.e. buildings, of the type, $n$ . . . . .	57
15	Appliances included in the load profile of the kitchen area. . . . .	58
16	Appliances assumed in the Kitchen during the hot season with high visitor activity. . . . .	58
17	Building types at the teacher area. . . . .	59
18	Appliances included in the load profiles for the Teacher's area. . . . .	59
19	Appliances assumed in the SR during the hot season throughout the week. . . . .	60
20	Additional appliances assumed in the SR during the weekdays in the hot season. . . . .	60
21	Additional appliances assumed in the SR during the weekends in the hot season. . . . .	60
22	Building types at the classroom area, and the number of Users, i.e. buildings, of the type, $n$ . . . . .	61
23	Appliances included in the load profiles of the classrooms. . . . .	62
24	Appliances assumed in $Class_{t1}$ in the hot season during the weekdays. . . . .	62
25	Appliances assumed in the Leap Learning Lab in the hot season during the weekdays. . . . .	62
26	Buildings related to the Director's housing, and the number of Users, i.e. buildings, of the type, $n$ , in the different scenarios. . . . .	63
27	Appliances included in the load profiles for the Director's housing. . . . .	64
28	Appliances assumed in $RB_1$ during the hot season. . . . .	64
29	Appliances assumed in the $RB_2$ during the hot season. . . . .	64
30	Building types in the Student dorm area. . . . .	65
31	Appliances that are included in the load profiles of the Student dorm area . . . . .	65
32	Appliances assumed in the Student dorm area during a week in the hot season. . . . .	66
33	Appliances assumed in a potential CL during the weekdays in the hot season. . . . .	67
34	Building types defined for the expanded visitor area. . . . .	68
35	Appliances assumed for the hangout area for visitors during hot season with high visitor activity. . . . .	68
36	Building types defined for the expanded visitor area during periods with low visitor activity. . . . .	68
37	Appliances assumed in hangout-area for visitors during hot season with low visitor activity. . . . .	68
38	Appliances assumed in the MPB throughout the weekdays. . . . .	69
39	Appliances assumed in the MPB in the weekends. . . . .	70
40	Appliances assumed for maintenance work in the WS. . . . .	71
41	Appliances assumed in the WS during the weekdays in the hot season. . . . .	71

---



---

42	The duty cycles of the circular saw. . . . .	71
43	Simulation variables for off-grid PV <sub>sys</sub> t simulations. . . . .	79
44	Results with grid connection with non-clustered solution and current system. . . . .	100
45	Summary of results. . . . .	107
46	Sensitivity analysis plane tilt. . . . .	118
47	Sensitivity analysis of optimal azimuth. . . . .	119
48	Final system proposal. . . . .	123
49	Overview of the power ratings of the appliances, and the source of these . . . . .	136
50	Appliances assumed in the VS during seasons with high visitor activity. . . . .	136
51	Appliances assumed in the VT during seasons with high visitor activity. . . . .	136
52	Appliances assumed in VH2 during the hot season with high visitor activity. . . . .	137
53	Appliances assumed in VH1 during seasons with low visitor activity. . . . .	137
54	Fan activity in VH1 during the cold season. . . . .	137
55	Appliances assumed in the SC the hot season during the weekdays. . . . .	137
56	Appliances assumed in the SC <sub>t</sub> in the hot season during the weekends. . . . .	137
57	Model input for the fan in the SR during cold seasons. . . . .	138
58	Model input for the fan in the SC during cold seasons. . . . .	138
59	Model input for the fan in the Office during cold seasons. . . . .	138
60	Appliances assumed in the SR during vacations. The parameters are adjusted to the hot season. . . . .	138
61	Model input for the fan in the SR during the vacations in the cold seasons. . . . .	138
62	Appliances assumed during the week in the Office. The parameters are adjusted to the hot season. . . . .	138
63	Appliances assumed during the weekdays by the Users in Class <sub>t2</sub> The parameters are adjusted for the hot season. . . . .	139
64	Appliances assumed during the weekdays in Class <sub>6</sub> . The parameters are adjusted for the hot season. . . . .	139
65	Appliances assumed during the weekdays in the PP buildings. . . . .	139
66	Appliances assumed during the weekdays in the ST. . . . .	139
67	Appliances assumed during the weekdays by the Users in Class <sub>t1</sub> during the cold season. . . . .	139
68	Appliances assumed during the weekdays by the Users in Class <sub>t2</sub> the cold season. . . . .	139
69	Appliances assumed during the weekdays in Class <sub>6</sub> during the cold season. . . . .	139
70	Model input for the fan in the LLL during cold seasons. . . . .	140
71	Appliances assumed in the SS when the students are staying at the property. . . . .	140
72	Appliances assumed in the ST when the students are staying at the property. . . . .	140
73	Appliances assumed in the SD in the cold season during the week. . . . .	140

---

---

74	Appliances assumed in the $Stor_{Dir}$ . . . . .	140
75	Appliances assumed in the $RB_2$ during the cold season. . . . .	140
76	Appliances assumed in the $RB_1$ during cold season . . . . .	141
77	Appliances assumed in the $RB_2$ in hot season during vacations. . . . .	141
78	Appliances assumed in the storage in the $Stor_K$ . . . . .	141
79	Appliances assumed in the Kitchen during the cold season. . . . .	141
80	Appliances assumed in the security building during the hot seasons. . . . .	141
81	Appliances assumed in the security building during the cold seasons. . . . .	142
82	Appliances assumed in a potential CL during the cold season. . . . .	142
83	Appliances assumed in the CL in the hot season during vacations. . . . .	142
84	Appliances assumed in the CL during vacations in the cold season. . . . .	142
85	Appliances assumed in the HA for visitors during cold season with low visitor activity.142	
86	Appliances assumed in the WS in the hot season during the weekends. . . . .	143
87	Appliances assumed in the WS during the vacations. Frequency is decreased for all appliances. . . . .	143
88	Appliances assumed in the WS in the cold season during the weekdays. . . . .	143
89	Appliances assumed in workshop in the cold season during the weekends. . . . .	143

---

## Acronyms

<b>AC</b> Alternating Current . . . . .	18
<b>AUG</b> Arkitekter Uten Grenser . . . . .	8
<b>DER</b> Distributed Energy Resources . . . . .	18
<b>DHI</b> Diffuse Horizontal Irradiation . . . . .	16
<b>DC</b> Direct Current . . . . .	16
<b>DNI</b> Direct Normal Irradiation . . . . .	16
<b>DoD</b> Depth of Discharge . . . . .	19
<b>Eco Moyo</b> Eco Moyo Education Centre . . . . .	ix
<b>EWB</b> Engineers Without Borders . . . . .	4
<b>GHI</b> Global Horizontal Irradiation . . . . .	16
<b>GTI</b> Global Tilted Irradiation . . . . .	17
<b>KenGen</b> Kenya Electricity Generating Company PLC . . . . .	13
<b>KPC</b> The Kenya Power and Lighting Company PLV . . . . .	13
<b>LCO</b> Lithium Cobalt Oxide . . . . .	21
<b>LCOE</b> Levelized Cost of Energy . . . . .	21
<b>LFP</b> Lithium Iron Phosphate . . . . .	21
<b>MmM</b> Master with Meaning . . . . .	4
<b>MPPT</b> Maximum Power Point Tracking . . . . .	22
<b>NPC</b> Net Present Cost . . . . .	124
<b>NGO</b> Non-Governmental Organization . . . . .	4
<b>PV</b> Photovoltaic . . . . .	15

---

<b>PVGIS</b> Photovoltaic Geographical Information System . . . . .	81
<b>RAMP</b> Remote-Areas Multi-Energy Systems Load Profiles . . . . .	11
<b>REA</b> Rural Electricity Authority . . . . .	12
<b>REREC</b> Rural Electrification and Renewable Energy Corporation . . . . .	12
<b>RMS</b> Root-Mean-Squared voltage . . . . .	26
<b>SDG</b> Sustainable Development Goals . . . . .	3
<b>SHS</b> Solar Home Systems . . . . .	25
<b>SoC</b> State of Charge . . . . .	19
<b>SSA</b> Sub-Saharan Africa . . . . .	3
<b>FT</b> Transposition Factor . . . . .	118
<b>UN</b> United Nations . . . . .	3
<b>UNEP</b> United Nations Environment Programme . . . . .	3

---

# 1 Introduction

## 1.1 Motivation

### Climate change

The world is currently experiencing severe declining biodiversity, intense droughts, catastrophic storms, water scarcity, melting polar ice, severe fires, flooding, and rising sea levels. These are consequences of climate change, which is defined as the long-term shifts in weather patterns and temperatures. Since the 1800s, the main driver of climate change has been human activities, most importantly due to burning fossil fuels such as gas, oil, and coal. This generates greenhouse gas emissions, which contribute to an amplified greenhouse effect. The greenhouse effect captures the long-wave radiation from the earth and results in rising temperatures. The mentioned consequences will happen more frequently and to a greater extent if the heating continues and will have a devastating impact on the planet. This will affect people's safety, health, housing, and ability to grow food. However, thousands of scientists and government reviewers have agreed that the worst climate impacts can be avoided by limiting the global temperature to 1.5° above pre-industrial levels (UN 2022c, UNEP 2022).

### Sustainable Development Goals

In 2015, the United Nations (UN) adopted the Sustainable Development Goals (SDG) as a universal call for action for protecting the planet, ending poverty, and ensuring that by 2030 all people experience prosperity and peace. The SDGs consists of 17 integrated goals which recognize that development must balance both environmental, economic, and social sustainability, as well as that action in one area affects the outcome in other areas (UNDP 2022c).

### Electricity access

SDG number 7 is regarding energy for sustainable development, namely to “ensure access to affordable, reliable, sustainable and modern energy for all”. The UN states that a new world of opportunities for billions of people through e.g. better health and education, empowered women, youth and children, jobs and economic opportunities, and greater protections from climate change, can be achieved through ensuring access to modern, sustainable, reliable, and affordable energy (UN 2022a). One of the most critical opportunities and challenges in meeting SDG 7 is the electrification of Sub-Saharan Africa (SSA) (DNV 2021).

At the same time, 759 million people in the world is without electricity access. This is 1 out of 10 people in the world. Most of these people live in rural areas, and three quarters live in SSA. Moreover, in Kenya, only 71 % of the population had access to electricity in 2019, whereas in the rural areas, the share is as low as 63 % (WBG 2022). In addition to the current high percentage of the world being population without electricity access, the world population continues to grow. Consequently, the demand for cheap energy also increases. Further, the main contributor to climate change is energy, accounting for 73 % of greenhouse gases from human activities (UNDP 2022a). The emissions driving climate change can be reduced by switching energy systems from fossil fuels to renewable sources such as solar and wind energy. The United Nations Environment Programme (UNEP) anticipates that a cut of 12.5 gigatonnes of greenhouse gas emissions can come from the energy sector through both shifting to renewable energy and using less energy (UNEP 2022).

### Education

SDG number 4 is regarding quality education, namely to “ensure inclusive and equitable quality education and promote lifelong learning opportunities for all”. One of the targets is that all boys and girls will complete free primary and secondary education (UN 2022b).

57 million children in the primary school age remain out of school, and one in four girls in developing countries are not in school. More than half of the 57 million children live in SSA. In addition, there are 103 million youths that lack basic literacy skills, and more than 60 % of them are women (UNDP 2022b). Education is one of the most powerful measures for sustainable development

---

and has an immense impact by e.g. improving health, gender equality, employment and poverty reduction.

### **Engineers Without Borders and Master with Meaning**

This master thesis is written as a Master with Meaning (MmM) on behalf of Engineers Without Borders (EWB) Norway. EWB Norway is a Non-Governmental Organization (NGO) contributing with technical competence and engineering in projects in developing countries. The vision is to use humanitarian engineering to promote development. The projects promotes sustainable technology and are based on the local needs. The projects contribute to the improvement of the life of people, as the solutions are operated and owned by the local community (EWB 2022). MmM is a concept developed to allow EWB Norway to assist engineering students in creating development-related master theses. This allows engineering students the opportunity to a great learning outcome in the field of humanitarian development, while by solving specific field problems it is actually of use to someone. A MmM consists of two parts; a theoretical part and a field visit to the project site. Hence, the master thesis consists of two parts; a theoretical work to establish proposals for optimized system solution, as well as field work at the project site conducted in March 2022.

### **Eco Moyo Education Centre**

Eco Moyo Education Centre (referred to as Eco Moyo from now on), is a primary school in rural Kenya offering free education to underprivileged children with a vision of increasing the quality of life for these children. The school is in Nzunguni village, which is a poor area where most of the children live without access to running water and electricity (EcoMoyo 2022a). A solid foundation needs to be established for the children in order to secure a better future for themselves and their families. Eco Moyo is contributing to building this foundation. Furthermore, the children also get school uniforms , food, and equipment such as backpacks, books, and pencils (EWB et al. 2020).

Developing a microgrid at Eco Moyo will contribute to achieving SDG number 7 regarding energy for sustainable development, targeted at the critical electrification of SSA. Eco Moyo itself contributes to achieving SDG number 4 regarding achieving universal quality education. The school also has a indirect impact on other SDGs, such as those related to no poverty, zero hunger, gender equality, clean water and sanitation, decent work and economic growth, and sustainable cities and communities. Therefore, Eco Moyo is found to be a suitable and important project to support and use as subject for this master thesis.

## **1.2 Objective**

The main objective of the master thesis is to analyze how system solutions for a microgrid can meet the electricity demand at Eco Moyo. In the fall 2021 a preliminary project was conducted by the authors. Results and experiences from this project established a starting point point for this master thesis. Field work is to be completed with the main purpose of data collection. After constructing load profiles and proposing different solutions for the electricity supply at the school, a specific system proposal is to be presented. Hence, the research question of the master thesis is defined as the following:

*What is the optimized system solution for a microgrid to supply the electricity demand at Eco Moyo Education Centre?*

The optimized system solution should entail a cost-effective system that supplies the load without being disproportionately sized. The system will be off-grid and renewable. However, backup solutions with grid connection and diesel generators will be evaluated as comparison. An important aspect of the thesis is that the boundaries and preferences that Eco Moyo defines should be accounted for. As the property is constantly evolving, it will be important to include future building prospects in the evaluations. Additionally, it is essential to consider feasible and available solutions locally in Kenya. Hence, the optimized system is not only determined by economic and technological considerations. The field work is a valuable resource when determining these limitations. In order to answer the research question, the following objectives are the main focus in the master thesis:

- Introduce necessary background theory.
- Perform field work to collect data and install a new system with PV panels and batteries.
- Define the boundaries of the project, and determine how to operate around these.
- Use collected data from the field work to establish annual load profiles.
- Perform simulations to propose possible solutions for system designs at the property.
- Compare off-grid solutions with PV panels and batteries with solutions including diesel generators and grid connection as backup solutions.
- Propose a system topology.
- Present the investment costs of the proposed solutions.

The main results of the master thesis will be a system proposal to be used as a guideline for the expansion of the electricity supply at Eco Moyo. The thesis will give an estimate on the possible future electricity demand at the property, and propose how it can be supplied. Suggestions on where the system can be distributed at the property will be included as well. An economic overview will be accompany the results. Several simplifications and assumptions will be made for the system proposal. The purpose is therefore to provide guidance rather than set specifications or limits on future installments. Additional details, considerations, and potentially components must therefore be accounted for if solutions are to be realized.

To offer a more comprehensive evaluation of the electricity supply, backup solutions with grid connection and diesel generators will also be presented. This is to provide a holistic understanding of the alternatives at the school. The work progress to obtain the objective is illustrated in Figure 2.

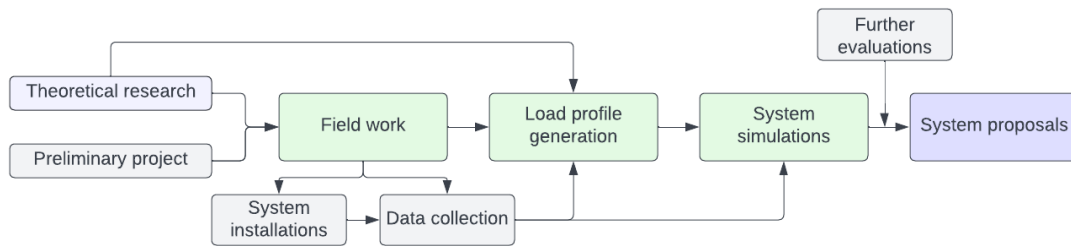

Figure 2: Illustration of the work progress in the master thesis.

## 1.3 Background

### 1.3.1 Eco Moyo Education Centre

Eco Moyo is a private primary school in a rural area in Kenya's east coast which offers free primary education to children. The vision of the school is to increase the quality of life for these children by providing free education to all the children in the village (EcoMoyo 2022a). Currently 240 pupils receive education at the school. The pupils also get breakfast and lunch, textbooks and other school material, uniforms and gear for physical education (EcoMoyo 2022b).

The school is a Norwegian and Kenyan charity project as it was founded in 2013 by Norwegian Lindsay Sanner. The school started as a vision of building a quality school with a green profile for children of low-income families (EWB et al. 2020, p.6). Hence the name Eco Moyo, as Eco is short for Ecology and Moyo means heart in Swahili. The school name therefore refers to showing love for the environment (EcoMoyo 2022a). This is an important aspect for the school, and a self-sufficient school in relation to food, water and energy, as well as financially independent, is desired.

---

## The area

Eco Moyo is located in a rural area in Kilifi county. This county is one of the poorest in Kenya, where 70 % of the population live under the poverty line. The school is located in the Nzunguni village. Most people in this area live without access to electricity or water in mud houses (EcoMoyo 2022c). Kenya has a young population, and in Kilifi County, 47 % are under 14 years of age. Only 50 % of the population in the area have completed primary school and only 13 % secondary school (EWB et al. 2020). Hence, many of the students parents have not themselves received education.

## The property

The Eco Moyo property is 10 acres, which constitutes to approximately 40,500 m<sup>2</sup>. The geographical coordinates of the property is latitude 3.5°S and longitude 39.8°E. This gives that the school is placed slightly south of the equator. The map placement of the school is shown in Figure 3.

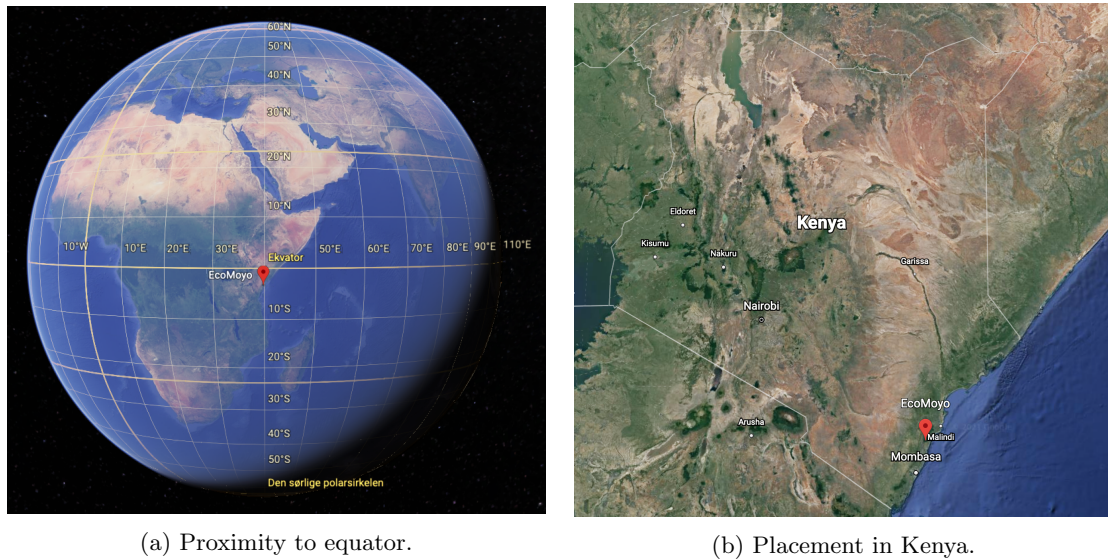

Figure 3: Eco Moyo map placement.

Source: Google Earth.

The school area currently includes 6 classrooms, 2 kindergartens, school toilets, office and storage, staff room, kitchen, sports fields, staff courts, and student dormitories. The two latter are due to that some of the teachers and approximately 20 of the students live at the school (EcoMoyo 2022b). The buildings are mainly established as clusters, big and small, organized around existing clearings. The different clusters are separated by relatively dense vegetation. Figure 4 shows an overview of the Eco Moyo property, whereas the existing clusters are marked. There are however continuous development at the property, and more buildings are expected to be built in the near future.



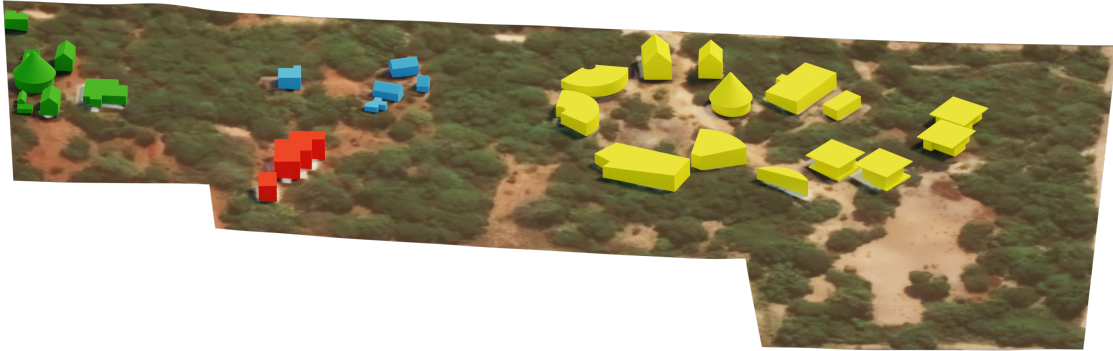

Figure 4: Existing clusters at the property.

Source: J. Lervik 2022.

The figure shows the cluster containing the security building, student dorms, and kitchen marked in green, which is next to the entrance at the site. The cluster including the housing for the director and the belonging storage is marked in red, while the area for visitors is shown in blue. Finally, the cluster including all buildings for school activities is shown in yellow.

### Architecture

The architecture at the site is the result of a broad architectural collaboration. Adaptation to the local climate was an important premise in the school building designs, and they allow for natural lighting and ventilation. They provide light and air through open structures, while at the same time offering protection from rain and the sun. The natural ventilation in the buildings, through liftings in the roofs to let the heat escape, is essential due to the strong heat at the site (EWB et al. 2020).



Figure 5: Drone picture of parts of the property.

Source: EcoMoyo 2022a.

---

### 1.3.2 Strategic plan

In 2020, a strategic plan for the further development at Eco Moyo was made by Lindsay Sanner, EWB Norway and Arkitekter Uten Grenser (AUG) Norway. The school's rapid growth made it necessary to compile future needs and look holistically at the development to be able to secure a sustainable development of the school. This plan addresses subjects such as land use, energy and water supply, and surface water management. Furthermore the plan gives a short overview of financial and organizational needs (EWB et al. 2020, p.6). This plan is actively used in this master thesis, both for data collection and to make sure that the schools needs and wishes are considered and accounted for.

## 1.4 Project boundaries

Several project boundaries can be defined for this project. Some of which will not be a part of the project scope, whereas other are defining for the work in this project. The most important aspects that have been considered for these boundaries will be presented in this chapter.

### 1.4.1 Current electricity supply

Firstly, the current electricity supply at the school must be considered before evaluating new options. The current electricity supply consists of three parts;

- A PV system installed during field work.
- A PV system that was already installed at the property before field work.
- Several Solar Home Systems (SHS), which are different types of small PV systems.

The school needs a robust and well-functioning system that can provide sufficient capacity and make the school self-sufficient in terms of electricity. All existing systems and solutions at the property, except from the installations that were completed during the field work, will not be considered in this thesis. By excluding unreliable systems, the goal is to propose a sustainable and reliable system that can supply the school energy needs for years without unnecessary additional investment costs.

### 1.4.2 Preliminary project

In the Autumn 2021 a preliminary project for this master thesis was written. The preliminary project established an important knowledge foundation for the master thesis. It explored different possible energy sources and system designs to suggest solutions that could be further investigated in the master thesis. Findings in this preliminary project set some important boundaries for the master thesis, i.e. in regards to source for energy production, method to be used for establishing load profiles, and simulation tool to be used for the system simulations. These boundaries and their background will be thoroughly explained in it's own chapter, Chapter 2.

### 1.4.3 Off-grid solution

As the school desires to be self-sufficient in regards to electricity supply, the main focus of the master thesis is an off-grid solution. Such off-grid systems will be further explained in Chapter 3.3.7. However, to offer a fully comprehensive evaluation, system simulations with grid connection will also be presented. This is to provide a holistic understanding of the alternatives at the school. grid connected solutions will not be a part of the resulting system proposals, as the desire to keep the school self-sufficient is prioritized.

---

#### **1.4.4 Preferences of end-users at the school**

To increase the satisfaction and sense of ownership of projects implemented at the school, the development of the system solution at the property will include social aspects and acceptance from the users. This will be done by facilitating participation from management, employees and pupils at the school when defining the energy needs during the field work. The prioritizing of new systems should also be adjusted to such social aspects as well. However, this will only be part of the discussion when recommending solutions, rather than a boundary when establishing the system solutions.

#### **1.4.5 Limitations of the local company**

It is decided by the school management that the local firm Chloride Exide Kenya Limited (referred to as Chloride Exide as of now) is to be used for further development of the electricity supply at the property. This company will be presented in Chapter 4. This decision was based on experiences with good quality work and a high level of professionalism of this firm for projects in the area. Thus, to provide an as accurate system proposal as possible, the methods and components Chloride Exide can offer is tried to account for. This is done both through conversations and collaboration with them, as well as using their website for references.

#### **1.4.6 Environmental considerations**

Eco Moyo's desire to maintain their so-called green profile must be reflected in their electricity supply as well. Hence, a fundamental boundary for this project is to focus on systems that take environmental aspects into considerations. This is mainly reflected in the choice of energy source, which is determined to be renewable. Because the school wants to maintain their environmental focus, other sources are not considered for the final system proposals in this project.

However, it is known to be a possibility to use both diesel generators and the main grid as an alternative if other electricity supply is insufficient. Such solutions will not be a main focus in this master thesis, but will be evaluated to ensure that information of alternative electricity supply is offered as well. To ensure that environmental considerations are included, emissions related to these solutions will be presented.

#### **1.4.7 Future expansions of the property**

An important aspect to consider for the future electricity supply at Eco Moyo is the future building projects that are expected. These projects are presented in the strategic plan (EWB et al. 2020). The buildings that will be prioritized in the near future have been mapped, and will be accounted for. These will be presented in Chapter 5.

#### **1.4.8 Clusters**

In line with the strategic plan, the system proposals will be adjusted to the clusters at the property (EWB et al. 2020). Even though there is a desire to keep each cluster self-sufficient, solutions that supply the whole property will be evaluated as well.

#### **1.4.9 Aspects that will not be considered**

Several considerations that are not included in the research scope of this master thesis. An overview of these main aspects are presented in this chapter.

---

## User flexibility

In the spring 2023 a direct follow-up master thesis of this master thesis is to be written. The master thesis shall investigate the flexibility of solar and battery off-grid systems, where Eco Moyo will be the case study for the thesis. This thesis will consist of a detailed study of the existing load, future load, lost load, current solar energy generation and battery systems. The goal is to identify energy consumption behavior patterns of users that maximize the utilization of PV and battery systems. This will include relevant tasks such as individual appliance load modelling, optimal utilization of existing system, and optimal consumption behaviour pattern suggestions. Hence, as a thorough analysis of user flexibility for Eco Moyo will be conducted in the master thesis, this aspect will not be a part of this project's scope.

## Interdisciplinary aspects

Three MmMs are currently being written for Eco Moyo regarding water supply. A the possibility of a water tank, a new well, and desalination of an old well are, amongst others, investigated. Surface water management is also considered.

The school is currently supplied with drinking water from the municipal pipe network. However, this is unstable and unreliable, and is especially challenging during the drought period. There is also a well on the plot, but the water is so salty that it can not be used. Updates and developments on the site in relation to water supply and handling are thus necessary. The solutions that are considered in the other master theses may require electrical energy, for example for pumping water. As results and solutions in relation to water supply will not be ready until June 2022, this is disregarded in this thesis. However, any further work with electricity supply at the school should take results from these master theses into account.

The master theses that should be taken into account if electricity demand in regards to water supply needs to be further evaluated are the following:

- Water Management and Rainwater Harvesting potential at Eco Moyo, Kenya by Maja Kirkhus.
- Water supply at Eco Moyo Education Centre in Kilifi, Kenya by Maria Brubak Melby.
- Design of an Underground Water Storage Tank in Coral Stone and Ferrocement at Eco Moyo Education Centre by Iver Nybø and Lukas Hartnik.

## Safety standards

Installations of microgrids entail safety concerns that has to be managed properly. However, relevant safety standards, and measures related to these, are not a part of the scope of this project.

## Control strategies

Control strategies of microgrids are important to ensure optimal operation of the system (Alfergani et al. 2018). However, specific control strategies of a microgrid will not be evaluated in this project.

## Detailed system topology

Simplified system topologies will be proposed in this master thesis. However, it is not a part of the research scope to propose details entailing connection points, cabling, or other specifications that do not need to be provided to perform sufficient system simulations.

---

## 2 Recommendations from the preliminary project

The preliminary project that was conducted during the fall 2021 established an important knowledge foundation for the master thesis. Similar to the master thesis, it evaluated possible solutions for a microgrid at Eco Moyo. The project explored possible renewable energy sources and system designs to suggest solutions that could be further investigated in the master thesis. Through reviews of relevant literature, it was found that common combinations of energy sources in microgrids are solar and wind, accompanied by batteries. Some alternatives also entail diesel generators to provide backup power when the renewable energy sources are insufficient. Possible system solutions can also be grid connected, either as backup, or as the main source of power supply. However, to provide a renewable, self-sufficient solution, a combination of wind turbines, solar panels, and batteries were chosen as for the system simulations. A system consisting of these components was therefore subject to a techno-economic optimization in HOMER Pro. The main purpose of this modelling was to determine which combination of energy sources are most suitable for Eco Moyo.

An important part of the objective of the preliminary project was to establish load profiles of the property. Because there are no opportunities of measuring the power consumption at the property, other methods were considered. Review of related research revealed that interview-based load profiles can entail high levels of inaccuracy (Hartvigsson and Ahlgren 2018, Hartvigsson, Ehnberg et al. 2015, Blodgett et al. 2017). This is amongst others because respondents wrongly estimate their own consumption. Additionally, it is difficult to account for random behavior with this method. However, interviews have the advantages that they are more attainable, and can be used as a tool to understand future needs. The responses can be utilized as inputs to stochastic models as well.

Bottom-up stochastic models, including the open-source tools LoadProGen and Remote-Areas Multi-Energy Systems Load Profiles (RAMP) (Mandelli et al. 2016, Lombardi et al. 2019), were reviewed as well. Both models take results from interviews to establish stochastic-basic load profiles. However, RAMP included increased the degree of stochasticity through their layered model. (Lombardi et al. 2019) presents that the error percentage stays consistently below 2 % when load profiles constructed in RAMP was compared to measured data. This is a significantly better model performance than what can be seen for results from LoadProGen (Lombardi et al. 2019). However, load profiles were established through a combination of pre-generated open-source load profiles (Narayan, Qin et al. 2020), and results from a user survey that was conducted in the fall.

After performing the system simulations, it was concluded that a combination of PV panels and batteries is the preferred choice for Eco Moyo. This was based on both economic evaluations, and the system performance. Additionally, PV panels do not entail the same challenges related to safety and maintenance as wind turbines do. It was found in the literature review that PVsyst could provide more detailed information about PV systems, and it was therefore recommended to use this tool for system simulations in the master thesis.

Even though the load profiles from the preliminary project provided a basis of knowledge about the electricity consumption at Eco Moyo, several moments of uncertainty are related to the results. Hence, it was established in the preliminary project that an important part of the master thesis should be to observe user habits during the fieldwork. It was also concluded that RAMP should be utilized when new load profiles are generated in the master thesis. Based on the model's high performance rate, this could increase the accuracy of the load profiles that can be generated based on results from the fieldwork.

---

## 3 Theoretical background

This chapter will present the theoretical background that has been introduced as a foundation for the research in this master thesis.

### 3.1 Kenya

#### 3.1.1 Electricity access

Kenya has high goals concerning electricity access. This is visible in Kenya's long term development strategy "Vision 2030". This strategy acknowledges energy access as a key enabler for making Kenya a "middle-income country providing high-quality life for all its citizens by 2030" (Vision2030 2022). As mentioned in Chapter 1.1, 71 % of Kenya's population had electricity access in 2019. In 1999 the electricity access was only at 13 %, which illustrates that the electricity access in Kenya has increased within the last two decades (WBG 2022). Hence, an immense effort has been put into the electrification of Kenya. One of these efforts was the establishment of Rural Electricity Authority (REA) in 2006. The purpose of REA was to enhance rural electrification in Kenya and to accelerate its pace (IPA 2022). In 2019, REA was changed to Rural Electrification and Renewable Energy Corporation (REREC), which has an expanded mandate of implementing rural electrification projects and of leading the green energy drive in Kenya. The mission of REREC is to "provide sustainable energy solutions for all through rural electrification and renewable energy for social economic transformation" (REREC 2022).

Even though great progress have been made in relation to the electricity access in Kenya, 29 % of the whole Kenyan population and 37 % of the rural Kenyan population lacks electricity access (WBG 2022). As Kenya has a population of 54 million this gives that 16 million people in Kenya still lack access to electricity (IEA 2022b).

#### Electricity generation mix

Kenya has an electricity mix with one of the highest renewable shares in the world, with approximately 89 % from renewable energy sources in 2019. The remaining 11 % is from oil (IEA 2022b). Figure 6 shows the electricity generation by source, showing that almost half of the electricity generation in the country is from geothermal energy. The figure also shows that PV production only accounted for 1 % of electricity production fed into the utility grid in Kenya in 2019 (IEA 2022b).

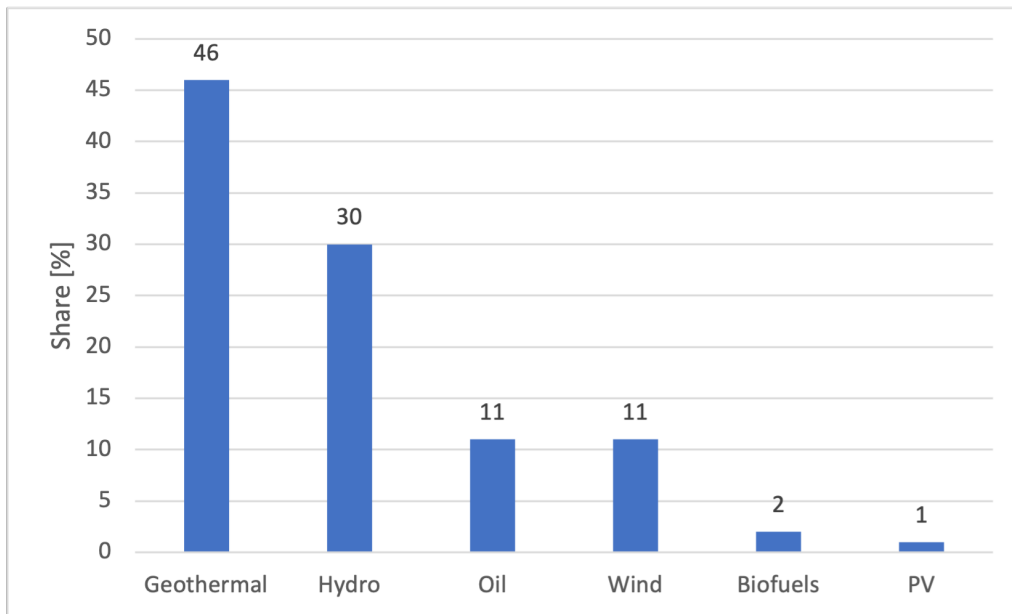

Figure 6: Electricity generation by source in Kenya 2019

Source: IEA 2022b.

Most of the electricity transmission and distribution systems in Kenya is owned and operated by The Kenya Power and Lighting Company PLV (KPC) (KPC 2022). Kenya Electricity Generating Company PLC (KenGen) is the leading company generating electrical power in Kenya and East Africa (KenGen 2022).

### 3.1.2 Climate in Kilifi

The climate in Kilifi is typically hot and humid, and has annual average temperatures around 26°C. Kenya has significant rainfalls and is considered to have two rainfall periods. A long wet period is from April to June, and a short wet season from October to December. The annual rainfall in the country varies greatly from 250 mm. in the north to 2,000 mm. in west (WBG 2020, p.4). In Kilifi there is 1,225 mm. annual rainfall (WorldWeatherOnline 2022). The average monthly rainfall in Kilifi is illustrated in Figure 7, and it demonstrates the two wet seasons.

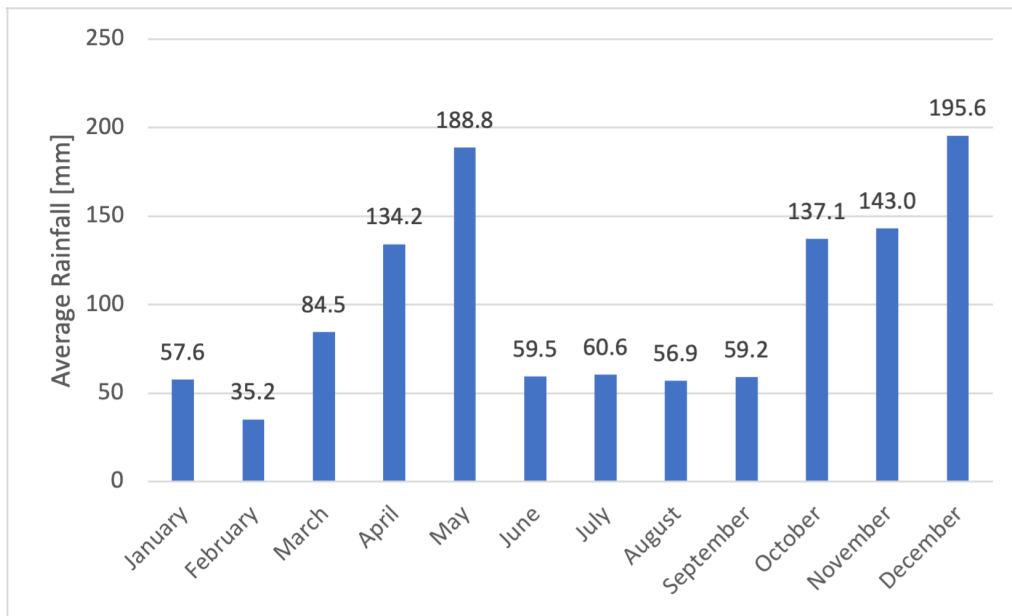

Figure 7: Average monthly rainfall in Kilifi.

Source: WorldWeatherOnline 2022.

Figure 8 shows the average global solar irradiation on the site from 1991 to 2010, and Figure 9 shows the average monthly temperatures.

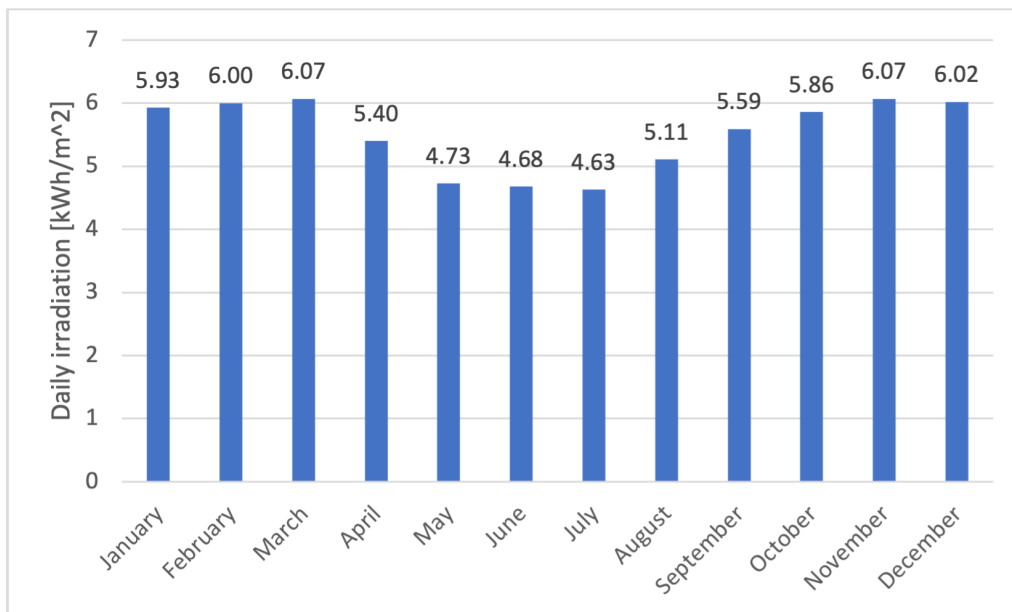

Figure 8: Average daily solar irradiation extracted from Meteonorm.

Source: Merlet 2021.

Figure 8 shows that the lowest average irradiation occurred in July with a value of 4.63 kWh/m<sup>2</sup> per day, and the highest in March and November with values equal to 6.07 kWh/m<sup>2</sup> per day.



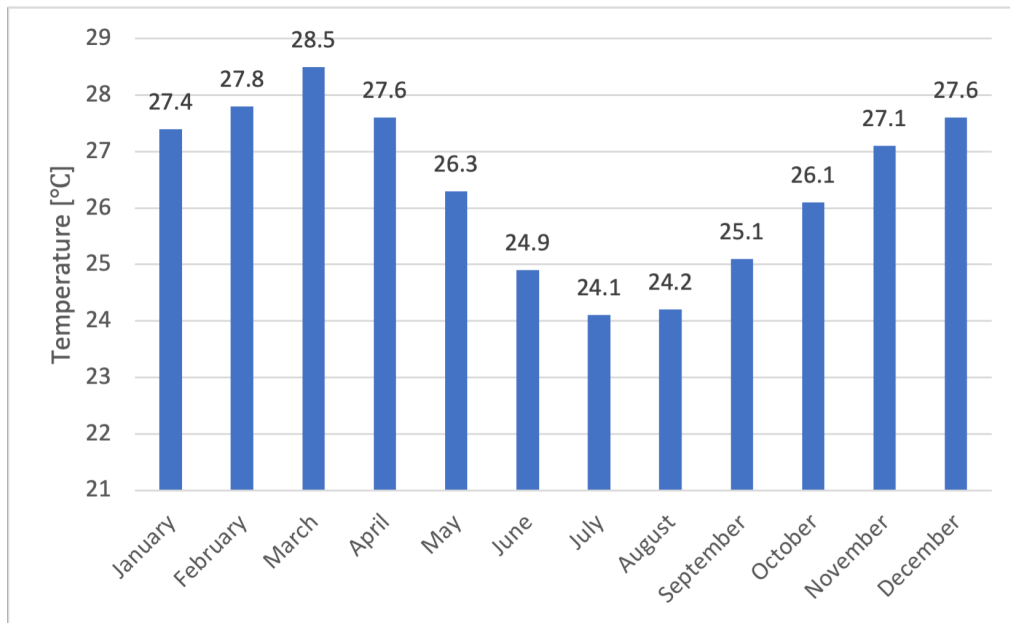

Figure 9: Average monthly temperatures extracted from Meteonorm.

Source: Merlet 2021

Figure 9 shows that the highest average temperature is in March with a value of 28.5 °C, while the lowest value is in July with 24.1 °C.

### Climate Change

It is essential to consider climate change when solutions adapted to future developments are to be developed. The ND-GAIN Index ranks the vulnerability of different countries to climate change, as well as the countries ability to improve the climate change resilience. Among 181 countries, Kenya rated poorly at 152, giving that the country is to highly vulnerable to climate change impacts (WBG 2020, p.3). An increased intensity and risk for climate change consequences in the country is therefore expected. In fact, a warming trend has already been visible in Kenya. Since the 1960s the mean temperatures has risen approximately 1.0°C, and it is predicted to rise another 1.7°C and 3.5°C by respectively the 2050s and 2100s (WBG 2020, p.9). An increase in droughts and dryness has also been witnessed. At the same time, a heightened intensity and frequency of extreme rainfalls is witnessed, arriving in uncertain and variable patterns (WBG 2020).

## 3.2 Solar energy and PV technology

Solar energy is the conversion of sunlight into usable energy forms, and it is a clean, inexhaustible and abundant source of energy (IEA 2020, Statkraft 2022). The sun is the largest source of energy on earth, and the amount of solar energy that hits the earth in one year is about 15,000 times greater than the entire world's annual energy consumption. The amount of solar energy reaching the earth's surface can vary from over 2200 kWh/m<sup>2</sup> per year to 700 kWh/m<sup>2</sup> per year, where the highest levels are received at the equator and decreasing towards the north and south pole (Hofstad 2022). Thus, this is an energy source with great potential for contributing to meeting the energy demand in the world and especially areas close to the equator.

It is normal to separate between technologies that generate electricity and technologies that do not. By using solar cells, solar energy can, through a Photovoltaic (PV) process, be directly converted to electrical energy. Historically this technology has been considered to be both expensive and to have a low efficiency, but both of these parameters have significantly improved the last few years. PV systems also operate with zero carbon-dioxide emissions, which is positive for the environment. A drastic drop in the price per installed power for PV technologies has been seen, which has led to

---

that in certain areas of the world this technology can compete with the price for electricity from the utility grid (Hofstad 2022). Hence, in this project the focus is on PV technologies and systems, as it is the most relevant technology used to cover the electricity demands at Eco Moyo.

Conclusively, all of the following theory, as well as the main focus of the master thesis, will be related to PV technologies.

### 3.2.1 Solar resource

The solar resource at a site is an essential parameter in PV systems, as power production is linearly dependent on the irradiance on the array plane. The term irradiance is given in  $\text{W}/\text{m}^2$ , as it is the power of the sunlight incident on a surface per unit area (Lumby 2015, p.29). Integrating the irradiance over defined time limits gives irradiation, and is a energy measurement rather than power measurement. It is the energy incident on a unit area of a surface in a given time period, and is given in  $\text{kWh}/\text{m}^2$  (Lumby 2015, p.14). Irradiation can be further divided into Direct Normal Irradiation (DNI), Diffuse Horizontal Irradiation (DHI), and Global Horizontal Irradiation (GHI). These terms are defined as follows:

- The DNI is the energy received per unit area of a surface due to solar radiation perpendicular to the surface.
- The DHI on the other hand is the energy received per unit area of a surface due to solar radiator scattered off surrounding areas or the atmosphere.
- GHI is the combination of DNI and DHI, i.e. the total solar energy that is received on a unit area of a horizontal surface.

GHI is the most relevant measurement for PV systems, as PV technologies are able to use both direct and diffuse irradiation. However, for technologies that are only able to use direct irradiation, the DNI is the most interesting (Lumby 2015, p.43).

### 3.2.2 The PV effect and PV cells

The PV effect is the generation of electric current and voltage in a PV cell when exposed to sunlight. The principle of this process is that two different layer types of a semiconductor material, called n-type and p-type, are set in contact with each other. Approximately 95 % of all PV cells that are produced, this semiconductor is silicon. The n-type layer has a surplus of free electrons in its outer shell, while the p-type has a deficit in free electrons in the outer shell, referred to as holes. By putting these semiconductors together, the surplus electrons move from the n-type side to the p-type side. This results in a negative charge along the p-type side and positive charge along the n-type side. This creates an electric field at the surface of where the two semiconductor layers meet. This area is called a n/p junction (Alireza Khaligh 2018, UngEnergi 2022).

At a point a balance in this junction will be reach. However, the energy from a photon, i.e. the sunlight, has the ability to release electrons in the junction area. The voltage across the junction causes the released electrons to move towards the n-type side. The resulting hole is filled by electrons from the p-type side. Consequently a new hole is created on the p-type side, which also will be filled by a new electron, i.e. the hole moves inwards in the p-type side. By connection PV cells together in a PV panel and connection this in a closed circuit, the electron initially released from the n/p junction will move through it and back to the p-type side. When this happens repeatedly, current is created (UngEnergi 2022). The current output of a PV cell is Direct Current (DC).

### 3.2.3 Main PV components

By connecting several PV cells together, typically 36, 60, or 72, a PV panel is created. The PV cells are connected in series and/or parallel to produce the desired current and voltage levels for

---

the given PV panel. PV panels can be further connected in series, which is referred to as a PV string. By connecting PV panels in series the voltage output is increased, while the current is constant. Moreover, PV strings can be connected in parallel, which constitutes to the final PV array. Connecting PV strings in parallel increases the total current, while the voltage is constant. Hence, by connecting PV panels to PV strings and PV strings to PV arrays, the total available power output is increased (AlternativeEnergyTutorials 2022).

### 3.2.4 Maximized production and loss reduction

An important aspect of PV systems is to maximize the annual PV energy production, for instance by reducing losses. This chapter explains some important factors that can reduce the losses.

#### Optimal plane tilt and azimuth

To maximize the PV energy production it is important to maximize the irradiation on the PV panels, i.e. the Global Tilted Irradiation (GTI). The GTI is the total energy received on a unit area of a tilted surface (Lumby 2015). Maximizing the GTI is done by facing the PV panel towards the sun for the longest possible period of time by finding the optimal plant tilt and azimuth. The tilt angle of a PV panel is the panel's angle relative to the horizontal plane.

As a rule of thumb, it is given that the tilt of the PV panels should be equal to the latitude of the site. However, it should not be less than  $10^\circ$  as this will increase waste and debris collection on the panels (Louie 2018). This will decrease the performance of the panels, and is further explained below in the section "Shading".

The plane azimuth is the angle between the PV modules and zero azimuth, where zero azimuth is at the celestial direction towards equator. I.e. zero azimuth is either due north or south depending if the site is on the northern or southern hemisphere. Further references to the term azimuth in this project will be with regards to a site position in the southern hemisphere. This gives that an azimuth of  $0^\circ$  is towards north,  $-90^\circ$  towards east,  $+/- 180^\circ$  towards south, and  $90^\circ$  towards west. A rule of thumb in regard to optimal azimuth for a PV array is that it should be oriented towards equator, i.e. an azimuth of  $0^\circ$ . Figure 10 shows the principle of tilt angle and azimuth, and shows a PV panel with a fixed tilt angle towards the south.

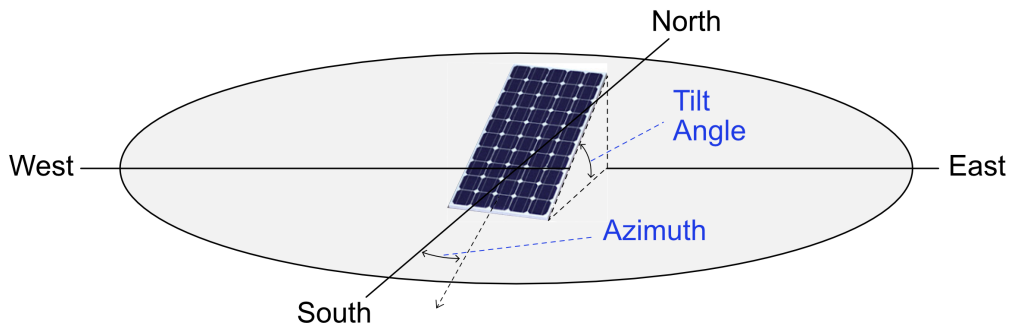

Figure 10: PV tilt angle and azimuth.

Source: SolarDesignGuide 2022.

#### Shading

Shading is an important factor as it has a significant impact on the PV energy production. This is due to that the current in the string of PV cells is defined by the current in the PV cell producing the least current. This gives that even though only a few PV cells are shaded, the PV panel performs as though they are all shaded. Hence, shading should be avoided. The shading can be a result of soiling, such as dust, bird droppings or other waste. This is temporary shading, and to reduce these losses, a cleaning strategy needs to be implemented. Shading from nearby objects

---

is often critical as it is often permanent and gives direct shadow. This includes objects such as buildings and trees. Shading can also occur from the PV strings themselves, where one row of PV string can cast shadow to the next PV string. In these cases it is important to find the optimal tilt and distance between the PV strings (TraceSoftware 2022).

### 3.3 Microgrids

A microgrid is an energy infrastructure consisting of Distributed Energy Resources (DER) and loads. The DERs are often from renewable energy sources, and the microgrids have the capability of supplying the loads autonomously (IRENA 2019). Microgrids encompass three subsystems; the power generation subsystem, a distribution subsystem, and the equipment and appliances for access and consumption. The power generation subsystem can entail for example PV panels, wind turbines, batteries and diesel generators. The generation capacity of microgrids can range from a few kilowatts to several megawatts. The distribution subsystem includes equipment that delivers the generated electricity from the power generating subsystem to the third subsystem. The third subsystem can include equipment such as ceiling fans and electrical meters. These three layers suffice to define a microgrid, but it can contain a fourth layer by integrating the microgrids to the utility grid (Sivaram 2018). The power losses in microgrids are mainly because of cable losses, voltage droops, and conversion losses (Opiyo 2019).

The microgrids are categorized as off-grid or grid connected. Grid connected microgrids are connected to the utility grid, by consuming and/or injecting power. This could give benefits to the consumer, such as improved reliability of supply, revenues from service provision, and electricity bill savings (IRENA 2019). It can also contribute to a greater share of renewable energies in the utility grid. Both grid connected and off-grid microgrids will be presented in this chapter. The main focus of this thesis is however on off-grid microgrids, which will be further explained in Chapter 3.3.7.

Both Alternating Current (AC), Direct Current (DC), and hybrid microgrids are possible. These microgrid types will be further explained in respectively Chapter 3.3.4, 3.3.5, and 3.3.6. Relevant components, such as batteries, converters, and parts of the distribution system will, however, initially be presented.

#### 3.3.1 The distribution system

The main purpose of the distribution system of microgrids is to ensure that power is transferred between the power generation and the consumer. They entail both distribution lines, transformers, low voltage lines, poles, protection, and monitoring equipment (Louie 2018). However, only the distribution lines will be introduced in this project.

Both AC and DC are possible alternatives for the distribution systems of microgrids. The choice between these two alternatives dates back to the twentieth century and the dispute between Thomas Edison and Nikola Tesla, respectively presenting DC and AC. In this quarrel, Tesla won due to that AC power could be sent over long distances without significant losses by the use of high-voltage AC. Using high voltage DC was however not yet possible, and DC could therefore not be sent over long distances. This has however changed, as changing the DC voltage has become immensely cheaper. This is done by DC/DC converters, which are introduced in Chapter 3.3.3. Hence, sending DC over long distances is now possible with low losses (Sivaram 2018).

Both real and reactive power flows in AC distribution systems, which entails both real and reactive power losses as well. The resistance in the cables depend on the length, cross-sectional area, frequency, and materials in use. In DC cables, there are no reactive losses. This allows for a higher capacity compared to AC cables. As evaluated in (Ekici and Kopru 2017), losses in the DC cable decrease when the cable cross section is increased. Losses could be decreased by using a larger cross-sectional area (Ekici and Kopru 2017). However, this increases the costs of the system.

(Louie 2018).

---

### 3.3.2 Batteries

The following section is directly extracted from the preliminary project (K. T. Lervik and Waitz 2021, p.19):

Batteries are necessary in microgrids to flatten out the irregularities in the energy supply from the intermittent renewable sources (Hansen and A.Xydis 2020). The battery system can supply the necessary power during periods of no or low generation from the renewable sources in the microgrid. Additionally, the batteries can supply the load during peak hours if the renewable power production is insufficient (Masters 2013). This will increase the stability and reliability of a system.

Lead-acid are commonly used in PV systems. However, as presented in (Diouf and Poda 2015), the PV industry have the potential of following the evolution in battery technology to a much larger degree than what it is currently. Lithium-ion batteries have therefore gained attention as an alternative as well. In the following sub chapters, these battery types will be presented in addition to some relevant terms.

#### Days of autonomy

The following section is directly extracted from the preliminary project (K. T. Lervik and Waitz 2021, p.20):

According to Henry Louie, the days of autonomy is “the number of days that the battery bank can supply the average load before being depleted, assuming it is not recharged during this period”. This can be due to less irradiation these days, e.g. due to clouds or factors such as that components in the PV system are broken. Typical values for days of autonomy is between 2 and 12 (Louie 2018, p. 401). A higher value gives a higher reliability, but it is important to note that this will also increase the costs due to increased battery bank capacity.

#### Depth of Discharge

The Depth of Discharge (DoD) represents a percentage value of the capacity that is discharged from a fully charged battery divided by the nominal capacity of the battery. A DoD of 0 % entails that the battery is 100 % charged (Hlal et al. 2019).

#### State of Charge

The State of Charge (SoC) is the complement of DoD. The following section is extracted from the preliminary project (K. T. Lervik and Waitz 2021, p.20):

To ensure long-lasting batteries, the batteries should not be overcharged or over-discharged. Overcharging occurs when a fully charged battery cell is kept charged. In relation to this, the SoC of a battery is an important term, which is defined as the remaining capacity divided by the rated capacity (Kularatna 2015). It should be between the limits as shown in Equation 1, where the  $SoC^{max}$  is the maximum capacity allowed for the battery and  $SoC^{min}$  is the minimum allowed capacity (Aemro et al. 2020, p.13).

$$SoC^{min} \leq SoC(t) \leq SoC^{max} \quad (1)$$

$SoC^{max}$  is the nominal capacity of the battery, and  $SoC^{min}$  is given by Equation 2.

$$SoC^{min} = (1 - DoD) \cdot SoC^{max} \quad (2)$$

---

where DoD is the Depth of Discharge. Thus, it is given that the minimum allowed capacity of a battery is dependent on the DoD.

### Cycle life

The following section is extracted from the preliminary project (K. T. Lervik and Waitz 2021, p.20):

The cycle life is defined as the amount of discharge and charge cycles a battery can have before the capacity is lower than a certain threshold value. A cycle refers to a sequence of charge and discharge, which is often completed in a day in most microgrids. Because the battery degrades over time, the battery capacity reduces as well. A threshold value of typically 60 % or 80 % of the initial rated value of the battery is therefore determined. When the battery capacity is lower than this value, it is said to have reached the end of its lifetime (Louie 2018).

The cycle life of a battery depends on the DoD. An increased DoD decreases the number of cycles before the battery reaches the end of its lifetime. The age of the battery also affects the cycle life, as the active materials will corrode over time and decrease the battery capacity (Louie 2018). Temperature effects can further increase this corrosion and reduce the battery lifetime.

The battery capacity represents how long a battery can supply a constant current load. This can be referring to either the amount of charge or the amount of energy a battery can supply the load (Louie 2018). This capacity depends on the SoC and the DoD, and hence the cycles. As a high DoD entails a decrease in cycles, the battery's lifetime decreases as well.

### Lead-acid batteries

Lead-acid batteries are common to use as energy storage in PV systems (Paul Ayeng'o et al. 2018). This is due to several advantages, such as low investment costs compared to other storage solutions, wide availability, and technical maturity (IRENA 2016, Paul Ayeng'o et al. 2018). The lead-acid batteries used in microgrids are often referred to as "deep-cycle" batteries. The positive electrode in these batteries consist of lead dioxide, while the negative electrode is made out of metallic lead. Lead-acid batteries with wet cells are referred to as flooded, while valve-regulated batteries are referred to as VRLAs. VRLAs can use gel or absorbed glass mat (AGM) sealed battery banks (IRENA 2016).

As the temperature is unregulated in many microgrid surroundings, the temperature effect on batteries should be considered. The effects on lead-acid batteries when the ambient temperature increases past 25°C are characterized by a decrease in internal impedance, and increased capacity. Hence, there are some positive aspects of a temperature increase. However, the self-discharge rate increases as well, while the cycle life decreases. These consequences are not compensated by the positive aspects, and the general performance is considered to worsen when the temperature is higher than 25°C (Louie 2018).

A disadvantage with lead-acid batteries is the strong limitation on operation (IRENA 2016). The batteries can deliver full power down to 50 % DoD (Kurzweil 2015), and it is common to limit the DoD to between 40 and 60 % to extend the battery lifetime. This entails that larger battery banks are required that what what would be needed if more of the battery capacity could be utilized. If the discharge rate is regulated, most lead-acid batteries last between 4 and 6 years if one cycle is assumed to last one day. However, as mentioned, other factors, such as unregulated temperatures, can shorten the lifetime (Louie 2018). The round-trip efficiency is a concern as well. Stored energy can drop between 10 % and 30 % during the storage process. Additionally, compared to other electrochemical-storage technologies, the usable energy density, given in  $\frac{Wh}{kg}$ , is lower for lead-acid batteries (IRENA 2016).

Another concern related to lead-acid batteries is that a high lead exposure has been found in workers and community neighbors of lead-acid battery manufacturing facilities. Additionally, even though the batteries are supposed to be 100 % recyclable, the actual percentage is lower, and a

---

recycling rate as low as 31 % has been calculated for a manufacturer in China. In rural areas, it is a challenge to ensure that the batteries are disposed properly as well (IRENA 2016).

### **Lithium-ion batteries**

Lithium-ion batteries are an emerging alternative to lead-acid batteries (IRENA 2016, Louie 2018). They present a relatively new technology that offers higher density, longer cycle life, less penalty of high discharge-rates, and a slower self-discharge than lead-acid batteries (Louie 2018). The average cell voltage of lithium-ion cells is typically 3.6 V, which represents a specific energy that is four times larger than for lead-acid batteries (Kurzweil 2015). This high energy density entails that less raw material is needed to provide the same battery capacity as a lead-acid battery, making it a more environmental friendly alternative as well (Diouf and Pode 2015).

Lithium-ion batteries have a positive electrode (i.e. anode) consisting of lithiated metal oxides, and a negative electrode (i.e. cathode) made out of carbon. The batteries have an electrolyte that contains lithium salts dissolved in organic carbonates (IRENA 2016). The most common material for the cathode is lithium cobalt oxide Lithium Cobalt Oxide (LCO), or  $\text{LiCoO}_2$ . Such Li-ion cells provide good cycle performance and high discharge voltages. However, they have the disadvantages of low thermal stability for operating temperatures (100-150°C) and accelerated aging at high currents. Lithium Iron Phosphate (LFP) batteries is another mature lithium-ion technology that entails high performance in regards to thermal stability and cycle life (Vega-Garita et al. 2019), amongst others. They are also considered the safest Lithium-ion battery type when taking thermal runaway risk into consideration. However, these batteries have the disadvantage of a lower energy density than other Lithium-ion batteries (Vega-Garita et al. 2019).

An important advantage with lithium-ion batteries is that the stored energy can be delivered efficiently due to their ability to be deeply discharged (Kurzweil 2015). Full power can be delivered with DoDs down to 80 %, which is significantly higher than for the lead-acid batteries (Kurzweil 2015). With a 80 % discharge, the life of a lithium-ion battery can range from 1000 to 5000 cycles (IRENA 2016). This is significantly higher than for the lead-acid batteries, which can have a cycle life of between 200 and 300 cycles with the same percentage of discharge (Diouf and Pode 2015). This entails that, compared to lead-acid batteries, the lithium-ion batteries can utilize more of the battery capacity without compromising its lifetime. Aging in lithium-ion batteries are however affected by degradation due to chemical reactions, and due to mechanical stress (Vega-Garita et al. 2019).

The round-trip energy efficiency of lithium-ion batteries are high, as it can be more than 90 % (Kurzweil 2015). Additionally, the battery can operate without the need of being fully recharged, and they can be charged more rapidly than lead-acid batteries (IRENA 2016, Louie 2018). This is beneficial during longer periods where fully charging is not possible. The batteries have a low self-discharge rate as well (Kurzweil 2015).

Lithium-ion batteries currently require high investment costs compared to lead-acid batteries (Diouf and Pode 2015, Paul Ayeng'o et al. 2018). However, as presented in (Paul Ayeng'o et al. 2018), the Levelized Cost of Energy (LCOE) can be lower for a lithium-ion battery than for lead-acid batteries for projects with long lifetimes. This is because the lithium-ion batteries are becoming more cost-competitive with the lead-acid batteries (IRENA 2016, Paul Ayeng'o et al. 2018), and because the lifetime of the lithium-ion batteries are longer (Paul Ayeng'o et al. 2018). This entails that less investments have to be made in new batteries during the project lifetime.

An advantage with lithium-ion batteries is that they are maintenance free. However, they require regulated temperature, as the range of operating temperature is low (IRENA 2016). This is both because it accelerates the degradation process, and because of capacity losses (Kurzweil 2015). Another disadvantage with lithium-ion batteries is that they entail some safety concerns (Louie 2018). The risk origins from the heat caused by intern short-circuits in the battery, which will increase the internal battery temperature. If the temperature reaches about 80 °, the heat-producing reaction occur. The consequences of such incidents is toxic gas release, and the possibility of the electrolyte to ignite. Additionally, these batteries are more complicated to recycle than lead-acid batteries, as they consist of different materials and components. Currently, the recycling rate is between 5 % and 25 %. Additionally, the availability of lithium is a concern globally (IRENA

---

2016). Hence, even though they require less raw material, and have longer lifetimes than lead-acid batteries, environmental issues are related to lithium-ion batteries as well.

### **3.3.3 Converters**

Converters serve many purposes in microgrids. They can function as an interface that enables components to interact. Some of these functions entail to regulate charging and discharging of batteries, to facilitate the power flow between buses in hybrid systems, and to maximize the PV production (Louie 2018). Some relevant converters will be presented in this chapter.

#### **Rectifiers**

Rectifiers convert AC voltage to DC. They can be both single- and three phase(Louie 2018).

#### **Inverters**

Inverters have the ability to convert DC voltage to AC voltage. These converters are for instance used to supply AC load by a DC system. Hence, they are essential in microgrids with DC buses, unless all load is DC. Some inverters have the ability to form the AC bus voltage and synchronize with other AC sources as well. Both three-phase and single-phase inverters can be used to obtain respectively a three-or single-phase output voltage(Louie 2018).

#### **Solar inverters**

Solar inverters are an inverter type specifically designed to connect PV arrays directly to AC buses. This removes the need for a DC bus. They are mostly used when there are no batteries or DC load that has to be connected through a DC bus. If the solar inverter is two-staged, it has one DC/DC conversion step before the DC/AC conversion. The DC/DC conversion step includes Maximum Power Point Tracking (MPPT). The solar inverters can also have one stage (Louie 2018). Hybrid solar inverters can allow for battery charging as well (Solar 2022).

#### **DC/DC converters**

DC/DC converters are used to regulate the DC voltage levels in a system. The most common types of DC/DC converters are boost, buck, and buck-boost converters. Boost converters increase the output voltage, whereas the buck converters decrease it. Buck-boost converters can do both (Louie 2018).

#### **Charge controllers**

Charge controllers regulate the charging and discharging of batteries. They serve the purpose of ensuring that the damage and degrading during charging is prevented. Some charge controllers are integrated with MPPT as well.

#### **MPPT controller**

MPPT are integrated with DC/DC converters, and ensure that the power production of the PV panels is maximized (Tabatabaei et al. 2020). A tracking algorithm controls the MPPT-controller, which regulates the power on the converter to the voltage level that ensures maximum power production (Rajani and Pandya 2016). Such a system topology ensures that the maximum output of the PV system is obtained (Rajani and Pandya 2016). A disadvantage with such solutions is that larger investments have to be made than for systems with DC-converter that do not have an integrated MPPT. The additional components also decrease the overall efficiency of the system (Rajani and Pandya 2016). Various control techniques are possible for MPPT charge controllers (Ezinwanne et al. 2017). However, as it is not possible to specify such techniques for the controllers that are available in PVsyst, these will not be further elaborated.



---

### 3.3.4 AC microgrids

The following section is directly extracted from the preliminary project (K. T. Lervik and Waitz 2021, p.13):

In an AC microgrid, all distributed energy resources and loads are connected to a common AC bus. Converters must be applied to connect both the DC generating units and the energy storage to the AC bus (Lotfi and Khodaei 2017, Louie 2018). (...)

All components in an AC microgrid are connected in parallel. This implies that they have to operate at the same voltage magnitude and frequency. Hence, the voltage outputs of the distributed energy resources are required to be synchronized (Louie 2018). Control of the bus voltage and magnitude is therefore an essential aspect of the AC microgrids, as these system values should be kept constant. This requires a grid forming component that can function as a voltage source at the AC bus. The other components must be synchronized to this voltage level. Therefore, to be able to inject power into the AC bus, they must be controlled as current sources.

If the load or generating units are AC based, AC microgrids can offer high efficiencies. They are compatible with grid connections as well. Additionally, they can provide both high resilience to failure, and be easy to expand (Veilleux et al. 2020). However, the system efficiency of an AC microgrid is reduced if the generating sources, or the load is DC. This is because conversions are needed between the AC bus and these components. The same conversions are needed when connecting the battery banks (Motjoadi et al. 2020).

### 3.3.5 DC microgrids

The following is directly extracted from the preliminary project (K. T. Lervik and Waitz 2021, p.14):

DC microgrids are grids that transmit, consume, supply, and maintain DC power to the loads (Motjoadi et al. 2020). In DC microgrids, one common DC bus connects all generating and storage units in the system (Lotfi and Khodaei 2017). The generating units are connected in parallel. AC components and loads must be integrated into the system through the use of converters(...). The battery bank determines the voltage of the DC bus in the microgrid (Louie 2018).

DC microgrids entail the advantages of reduced power losses and an increase of capacity in the transmission lines compared to the AC microgrids (Andreu et al. 2014). This is partly because there is no reactive power flow on the transmission lines. It is also because the DC distribution system entails fewer conversion steps, as both PV panels, batteries, and loads are directly compatible with DC microgrids (Aemro et al. 2020). This allows for a more efficient supply of DC loads as well. Unlike AC microgrids, the generators do not have to be synchronized, allowing them to operate at their optimal speed.

A disadvantage of DC microgrids is that low voltage levels in some systems can lead to high DC currents, which require more expensive components. The batteries have to be protected from being over- or undercharged, and hence DC microgrids should contain a charge controller to limit the current from the renewable energy sources. Additionally, if the load is AC, the efficiency will be reduced, as the power has to be converted (Veilleux et al. 2020).

An illustration of a DC microgrid that supplies the DC load directly from the DC bus is presented in Figure 11.

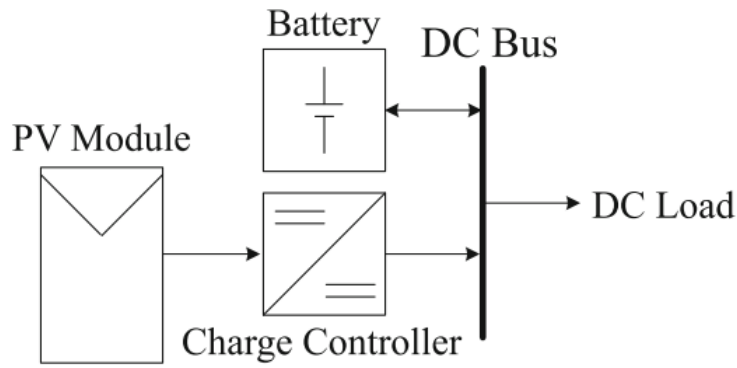

Figure 11: System topology for a DC microgrid with DC load.

Source: Louie 2018, p.92

### 3.3.6 Hybrid AC and DC microgrids

The following section is directly extracted from the preliminary project (K. T. Lervik and Waitz 2021, p.14):

Hybrid microgrids can consist of both AC and DC buses. Such microgrids usually consist of an AC distribution system with a DC expansion connected through a bidirectional converter. This system can allow for a high degree of efficiency, as the AC power production and load can be directly connected to the AC bus, while the batteries can be connected to the DC system. The PV system can supply both the AC and DC load through an MPPT charger or a DC to AC converter (Veilleux et al. 2020).

Even though they can provide high efficiencies, solutions with bi-directional converters are not considered further as a part of the project scope. An illustration of a hybrid microgrid with both an AC- and DC distribution system is presented in Figure 12.

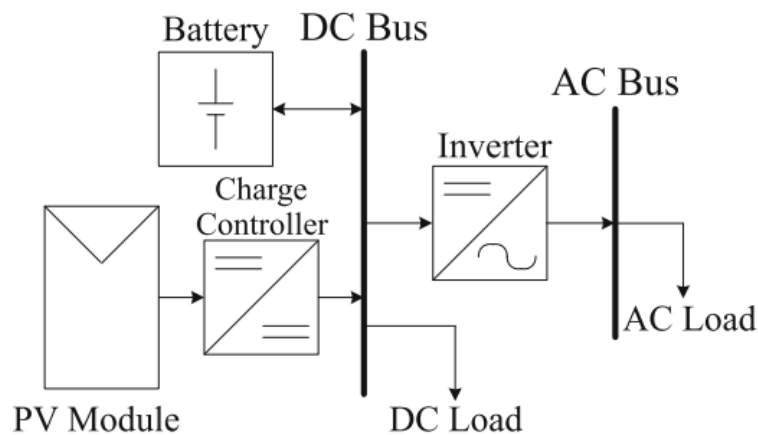

Figure 12: System topology for a hybrid AC and DC system.

Source: Louie 2018, p.92

---

### 3.3.7 Off-grid microgrids

Off-grid microgrids are fully autonomous systems, and are especially viable solutions for remote areas with problems in relation to the utility grid such as long distances and unreliable power supply (IRENA 2019). In off-grid PV microgrids, the PV array either charges a battery, or delivers the power directly to the user. For systems complemented with batteries, these will be charged or discharged depending on the PV array production and the power consumption. A controller regulates this energy balance by disconnecting the PV array when the battery is full, or disconnecting the user if the battery is empty. This is mainly to protect the battery (PVsyst 2022g).

Solar Home Systems (SHS) are suitable for systems with small power consumption, from approximately  $50 W_p$  to  $200 W_p$ . This entails appliances such as lights, phones, computers, radio, or TVs). SHS are simple systems where the PV arrays usually are directly connected to the battery. Hence, the PV array voltage is related to the battery pack voltage, and the PV panels should therefore often be 12 V or 24 V. These systems include simple controllers that either short-circuits the PV modules or disconnects the battery when it is full (PVsyst 2022g).

There has been a rapid increase in the number of SHS installed in Kenya, and it has been estimated that around 320,000 households were connected to SHSs in Kenya in 2010 (Adwek et al. 2020). Figure 13 presents a typical SHS that is utilized in rural areas. It includes a 11 W solar panels that allows for LED lights and phone charging. Similar systems are currently used at Eco Moyo as well. Such solutions are referred to when using the term SHS further in this project.



Figure 13: Solar Home System.

Source: Sun 2022.

### Off-grid microgrids with diesel-generator as backup

Diesel-generators can be an important part of off-grid solutions, to ensure that the power supply is reliable. This is particularly important when other power production is low, or when the power consumption is high (Wiemann et al. 2014, p.6). Renewable energy production are dependent on having access to the relevant energy sources when power is needed, whereas a generator can be supply the load whenever it is needed (Wiemann et al. 2014, p.12).

Diesel generators usually output AC power, which entails that an AC/DC converter must be

included in the system if batteries are included, or if the microgrid is DC coupled (Wiemann et al. 2014). The lifetime of a diesel generator is usually between 3 to 5 years when they are continuously in use. However, if the usage is reduced, its lifetime can be expanded up to 20 years (Wiemann et al. 2014). If the generator only serve the purpose of being a backup solution, they can be expected to have a long lifetime in microgrids where they are not the main power source. There are several disadvantages related to the use of diesel-generators. Firstly, fuel prices can be expensive. (Wiemann et al. 2014, p.6) Secondly, a challenge in rural areas is that diesel fuel might not be accessible when needed. Using the generator also entail CO<sub>2</sub> emissions, local air pollution, and noise (Wiemann et al. 2014). Another drawback is that generators require maintenance, repair, and occasional replacements of moving parts. Such maintenance require trained technicians, and the availability of the generator parts that have to be replaced (Louie 2018). Additionally, the possible conversions that are needed for the generator to supply the load can entail both increased investment costs and system losses.

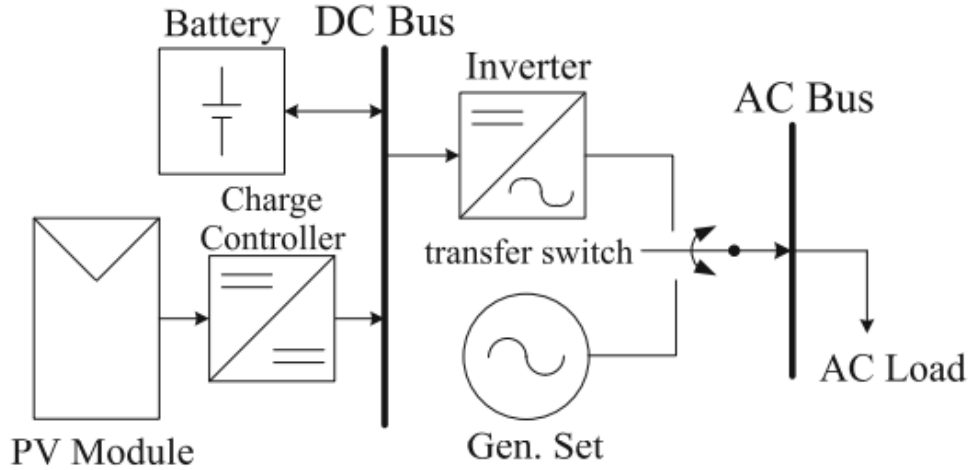

Figure 14: Illustration of a microgrid with a diesel generator as a backup power supply

Source: Louie 2018, p.95

### 3.3.8 Grid connected microgrids

For grid connected system, AC distribution lines are needed for power to flow between the microgrid and the grid. Such distribution lines are usually over-head in rural areas as this solution is less expensive than underground solutions. The distribution lines consist of three phase conductors, and its nominal voltage refers to the Root-Mean-Squared voltage (RMS) magnitude of the line-to-line voltage. The relationship between the line-to-line voltage and the line-to-neutral voltage of three-phase system is given by Equation 3 (Louie 2018, p. 57).

$$V_{\phi} = \frac{V_{ll}}{\sqrt{3}} \quad (3)$$

where

- $V_{\phi}$  is the nominal line-to-neutral voltage of the distribution line
- $V_{ll}$  is the line-to-line voltage

Common nominal voltages are usually 11 kV, 22 kV, or 33 kV. These values are referred to as medium-voltage. The voltage level that supply households are referred to as low-voltage, and typically have magnitude of 120 or 230 V. Transformers are therefore needed to ensure that the

---

voltage levels are adjusted to supply consumers. The secondary side of a transformer is therefore usually 400 V line-to-line voltage, entailing a 230 V single-phase voltage (Louie 2018, p.57).

The microgrid can be operated in off-grid mode, where it is not supported by the utility grid. In that case, the frequencies and voltages have to be regulated by controlling devices. When additional power supply is needed, it can be connected to the main grid. In that case, the voltages and frequencies are regulated by the grid (Rajesh et al. 2017).

### 3.4 Load profiles

The following sections are extracted directly from the preliminary project (K. T. Lervik and Waitz 2021, p.9):

Load profiles can be defined as “the power demand of an energy system mapped over time” (Narayan, Qin et al. 2020, p.200). To ensure a well-dimensioned microgrid, it is essential to understand the electricity usage of the load that will be supplied (Hartvigsson and Ahlgren 2018). Using appropriate load profiles for the system is essential to avoid dimensioning the system with components of disproportionate sizes. If the load is underestimated, the system will not be able to supply the actual load, and hence the reliability of the system decreases. On the other hand, an overestimated load will cause inefficient use of capital, as the components, will be larger than needed (Louie 2018, Hartvigsson, Ehnberg et al. 2015).

In a smaller system, such as the one evaluated for Eco Moyo, the load profile is highly dependent on each user. Hence, it is important to be as accurate as possible, and both short-term and long-term behavior should be understood (Hartvigsson, Ehnberg et al. 2015). It is, however, difficult to estimate changes in behavior before and after installation of such a system, especially when the consumers do not used to having electricity access (Blodgett et al. 2017). However, even though it is hard to predict future energy consumption, the trend is an overall increase in demand over time (Hartvigsson and Ahlgren 2018).

There are several methods for establishing load profiles, such as user surveys or interviews, stochastic modelling, and data-driven approaches. The latter needs measured data. As there are currently no available tools to measure energy consumption over time at the property, data-driven approaches will not be further evaluated for Eco Moyo. Some relevant terms will be presented in this chapter.

#### 3.4.1 Peak and average load

The following is extracted directly from the preliminary project (K. T. Lervik and Waitz 2021, p.10).

The peak load of a system can be defined as the maximum power consumption that occurs during a period of time (Narayan, Qin et al. 2020). Therefore, a system must be designed to supply these peaks. The minimum acceptable power rating for system components, such as the converter, is therefore determined accordingly (Louie 2018).

The average load is the mean load during a period of time. Components are not sized according to this value, as it does not capture the largest peaks in the consumption (Narayan, Qin et al. 2020).

#### 3.4.2 Energy consumption

The following section is extracted directly from the preliminary project (K. T. Lervik and Waitz 2021, p.11):

---

The energy demand of a day can be calculated as the integral of instantaneous power demand, as presented in Equation 4 (Narayan, Qin et al. 2020).

$$E_j = \int_{t=0}^{t=24h} P_i(t) dt \quad (4)$$

where

- $E_j$  is the total energy demand during day  $j$  [ $Wh$ ]
- $P_i(t)$  is the instantaneous load at hour  $t$  [ $W$ ]

The calculation of the total energy consumption over a time period with  $n$  number of days is presented in Equation 5.

$$E_{tot,n} = \sum_{i=1}^{i=n} E_j \quad (5)$$

where

- $E_{tot,n}$  is the total energy consumed during  $n$  number of days [ $Wh$ ]
- $E_j$  is the total energy demand during day  $j$  [ $Wh$ ]

The average daily energy consumption is defined as the total daily energy consumption over a period of time divided by the total number of days in the period (Narayan, Qin et al. 2020, Louie 2018). Hence, it can be calculated as presented in Equation (6) (Louie 2018).

$$E_{avg} = \frac{E_{tot,n}}{n} \quad (6)$$

where

- $E_{avg}$  is the average daily energy consumption [ $Wh$ ]
- $E_{tot,n}$  is the total energy energy consumed during  $n$  number of days [ $Wh$ ]
- $n$  is the number of days in the period

### 3.4.3 Bottom-up load profile construction

The following section is extracted directly from the preliminary project (K. T. Lervik and Waitz 2021, p.12):

Techniques for modeling residential load profiles can be categorized into top-down and bottom-up approaches (Swan and Ugursal 2009). An illustration of these categories is presented in Figure 15. Top-down approaches determine the effect of long-term consumption and do not distinguish individual end-user consumption. Some common variables in the top-down models are macroeconomic indicators, climate conditions, and the number of units in the residential sector (Swan and Ugursal 2009).

Bottom-up approaches account for the variations in energy consumption of each consumer, before aggregating the load to sub-groups and groups. These aggregations can in this way represent lower hierarchical levels instead of one large sector (Swan and Ugursal 2009).

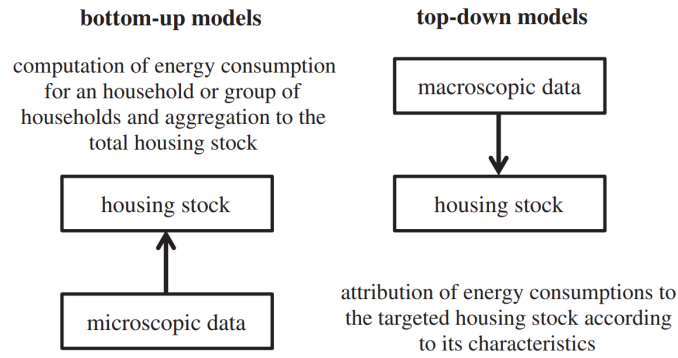

Figure 15: Top-down and bottom-up procedures to establish load profiles.

Source: Mandelli et al. 2016, p.131

The variables related to top-down models are not considered relevant when establishing the load profiles for Eco Moyo at the detailed level that is considered. Hence, this approach will not be considered in this master thesis. However, bottom-up approaches are suitable as individual user behavior can be accounted for. Additionally, bottom-up approaches are more feasible, as the required data is obtainable. Two bottom-up methods that are relevant for this master thesis will be introduced. This is respectively user surveys and the bottom-up stochastic model that is presented in Chapter 3.6.1.

### Interview-based models

One of the reasons that generating load profiles is complicated, especially in rural areas, is the high complexity that is associated with predicting the actual needs as they depend on different factors. Due to lack of measured data in rural areas, these load profiles are usually based on information collected through interviews and surveys.

The following section is extracted directly from the preliminary project (K. T. Lervik and Waitz 2021, p.12):

A standard user survey approach to estimate energy consumption involves creating a questionnaire to establish an inventory of current and likely future appliances. This is done to determine power ratings and predict these appliances' daily usage. The microgrid's average daily energy need can then be calculated and aggregated. If the user survey is constructed to capture what time of the day the appliances are used, an hourly load profile can be constructed as well (Blodgett et al. 2017). After obtaining this information, load estimation can be performed using bottom-up approaches (Louie 2018). Even though user survey is a widely used tool, several sources of error are associated with this method. For instance, the respondents might have trouble accurately predicting their usage patterns and the appliances that will be acquired once the electricity access is available. This is particularly difficult if the respondents are not used to having electricity access. Additionally, the questions formulated in the surveys might not be properly formulated or specific enough (Louie 2018, Hartvigsson, Ehnberg et al. 2015).

### Bottom-up stochastic models

Stochastic approaches are common in modelling tools to reproduce the unpredictability in human behavior. When generating load profiles for cases in rural areas with little to zero energy, the load profiles should account for appliances that can be relevant in the future when more energy becomes available. It is very difficult to predict usage patterns, and the probabilities and statistics related to them, of activities that does not yet exist. Stochastic models can allow for collected data, for instance through user-surveys, to be subject to randomly variations. This can, for instance, entail

---

to imitate the unpredictability in user patterns related to time frames and duration of appliance usage through Markov-chain models (Lombardi et al. 2019).

### 3.5 Economy

#### 3.5.1 Levelized cost of energy

The LCOE is an important indicator when evaluating different energy solutions. The LCOE provides a metric that makes it possible to capture the cost of a specific energy producing technology, and results in values denoted by price per kWh. This represents all costs that are needed for a given electricity output. Simplified, the LCOE can be calculated as presented in Equation 7 (Primer 2022).

$$LCOE = \frac{C_{tot}}{E_{tot}} \quad (7)$$

where

- $C_{tot}$  denotes the total lifetime cost
- $E_{tot}$  denotes the total lifetime energy production

### 3.6 Presentation of external modelling tools

External modelling tools will be utilized both for the construction of load profiles and for simulations of the systems that are considered for Eco Moyo. These tools are respectively RAMP and PVsyst, and will be presented in this chapter.

#### 3.6.1 Remote-Areas Multi-Energy Systems Load Profiles

RAMP is a bottom-up stochastic model constructed by (Lombardi et al. 2019). The model generates high resolution multi-energy load profiles for remote area energy systems. It uses interview-based input data, and to account for the high degree of uncertainty of this data, the RAMP model adds a high degree of stochasticity. The model is open-source and implemented in Python, which allows for adaptability and customisability. Hence, it is a highly flexible approach which ensures that the model can be applied to different contexts.

##### Model layers and input data

The model consists of the three hierarchical layers of modelling. These layers are denoted as User type, User, and Appliance. The first layer, i.e. the User type, is typically a type of building. Subsequently, the User types can be further divided into the second layer, which is the Users, depending on how many users there are of the given User type. Furthermore, the required amount of the third layer, Appliances, associated with each User can be defined. A sketch of the modelling layers in RAMP are shown in Figure 16.

This model construction ensures that every single User has a unique generation of electricity usage related to them. This is because the user behavior related to each appliance is modelled independently. The total load profile is a combination of all the independent electricity usage related to the Users. By including unpredictable and random user behaviour, the resulting total load profile is different every time the model is run. This ensures that the RAMP model is able to reproduce both day-to-day fluctuations and average daily load profiles with good approximation (Lombardi et al. 2019).



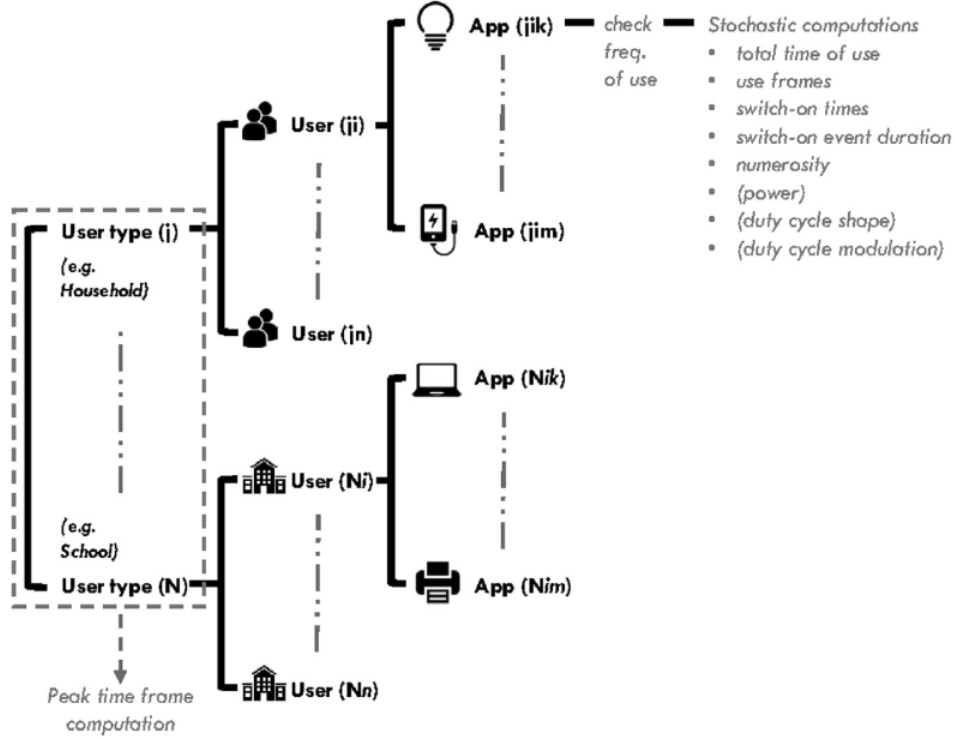

Figure 16: The modelling layers in RAMP.

Source: Lombardi et al. 2019, p.435.

Several model input can be provided to RAMP, for instance to simulate thermal applications. However, such applications are not a part of this project's scope and will therefore not be introduced. Relevant input variables are presented in Table 1.

Table 1: Input data required by RAMP-model.

Input data		Description
User type <sub>j</sub>	[-]	User type name
n	[qty.]	Amount of Users <sub>ij</sub> in User type <sub>j</sub> .
Appliance <sub>jik</sub>	[-]	Name of k-th Appliance associated with the j-th User type and i-th User.
m <sub>jik</sub>	[qty.]	Number of appliances of Appliance <sub>jik</sub> .
P <sub>jik</sub>	[W]	The power absorbed by Appliance <sub>jik</sub> .
tot_use <sub>jik</sub>	[min]	Total time of use of the Appliance <sub>jik</sub> during a day.
t_min <sub>jik</sub>	[min]	Minimum time the Appliance <sub>jik</sub> is kept on after switched on.
δ <sub>t_min,jik</sub>	[%]	Random variability applied to t_min <sub>jik</sub> .
use_frames <sub>jik</sub>		The time windows the Appliance <sub>jik</sub> can be randomly switched on.
δ <sub>frames,jik</sub>	[%]	Random variability applied to use_frames <sub>jik</sub> .
cycle <sub>jik</sub>		Duty cycle of Appliance <sub>jik</sub> . Optional. Up to three per appliance.
δ <sub>cycle,jik</sub>	[%]	The random variability that is applied to the cycle <sub>jik</sub> segments. Optional.
cycle_mod <sub>jik</sub>		Relation between different duty cycles and time windows. Optional.
frequency <sub>jik</sub>	[%]	Weekly frequency of use of Appliance <sub>jik</sub> . Optional.
fixed_num <sub>jik</sub>	[%]	Simultaneous switch-on constraint for all m <sub>jik</sub> appliances. Optional.
δ <sub>P,thermal</sub>	[%]	Random variability applied to P <sub>jik</sub> . For thermal appliances. Optional.

Source: Lombardi et al. 2019, p.435

A key attribute of the RAMP model is the possibility of adjusting the degree of randomness of parameters related to user behavior. This applies to both time windows and the minimum duration of usage. Such parameters are respectively denoted as  $\delta_{cycle,jik}$  and  $\delta_{t_{min},jik}$ . Another important

---

advantage of the model is that it provides the opportunity to define usage frequency. This entails that the appliance is only included in the set of appliances that a User is modeled to be used in accordance with a random probability check. This gives the individual User a unique random characterization and recreates realistic usage patterns of appliances that are not used daily. The attribute is denoted as  $\text{frequency}_{jik}$  in Table 1. It is also possible to define if a quantity of the same appliance is used simultaneously and to differentiate between weekend and weekday behavior (Lombardi et al. 2019).

Another important aspect of the RAMP model is the opportunity to use duty cycles. This can for instance be done to modulate appliances that has an electricity consumption that varies with external factors, such as temperature effects or user behavior. Fridges or freezers are examples of such appliances. The duty cycles can also be used to construct reproduce behavior of behavior that has a high degree of randomness related to it, such as cooking (Lombardi et al. 2019).

### 3.6.2 PVsyst

PVsyst is a software for the analysis of off-grid, grid connected, and pumping PV systems (PVsyst 2022b). It can simulate and design systems consisting of, amongst others, a converter, PV panels, and batteries. PVsyst offers databases comprised of components and geographical data. Several parameters can be defined for the PV panels, such as the tilt angle and the azimuth (Morshed et al. 2015). Additional details about other conditions, such as shading, can also be specified. Component prices, investment costs, and additional costs can be included to give a detailed economic evaluation (PVsyst 2022b).

Simulation results from PVsyst entail highly informative data, such as detailed loss diagrams, simulation parameters related to system performance, and electricity usage. Furthermore, hourly values can also be presented as hourly or daily plots (PVsyst 2022e, PVsyst 2022d). Due to the ability to provide detailed information about systems and their performance, PVsyst is a good option for designing stand-alone PV systems (Morshed et al. 2015).

---

## 4 Fieldwork

This chapter presents the fieldwork conducted in March 2022, and the data and experiences that it resulted in. The fieldwork provided several purposes, which can be summarized as follows:

- Data collection about the property, buildings and electricity demands.
  - Physical measurements of all relevant data, such as distances, roof areas, roof angles, and azimuths. Evaluations of which buildings that can hold new PV installations on them were also performed.
  - Analysis of all buildings at the property in order to understand the electricity demands.
  - Conversations with staff and pupils to gain further insight into electricity demands.
- Additional observations and experiences to understand possibilities and boundaries at the school.
- Funding from EWB allowed for the installation of a new PV system at the property. This also included the relocation of an existing PV system. The installation was planned beforehand, and meetings and arrangements with the local company were therefore performed. These installations are relevant as they will be accounted for in the system evaluations and proposals.

### 4.1 Data collection

An essential outcome of the fieldwork is the collected data about user habits, school activities throughout the year, and the buildings at the property. A combination of observations, interviews, and conversations with staff and pupils at the school have ensured detailed knowledge about the property and the electricity demands. This data has established the foundation for the load profiles, as well as for the possibilities and boundaries that are considered when evaluating new PV system proposals for Eco Moyo.

#### 4.1.1 Annual school schedule and vacations

To understand the electricity demands at Eco Moyo throughout the year, it is important to obtain information about the annual school schedule. This is in order to determine when there are staff and pupils at the property and when the teaching activity ceases. Conversations with staff gave that the school vacations are determined by a calendar that the Ministry of Education publishes in Kenya. There are four vacations each year. These are in February, April, August, and November to December. An overview of a typical school year and the vacations is presented in Table 2.

Table 2: Typical annual school schedule for Eco Moyo.

Start date	End date	School activity
January 1	January 31	Regular
February 1	February 7	Mid-term vacation
February 8	March 31	Regular
April 1	April 30	Vacation
May 1	July 31	Regular
August 1	August 31	Vacation
September 1	November 15	Regular
November 1	December 31	Vacation

Table 2 shows that the mid-term vacation in February usually lasts for a week. As this vacation is relatively short, the boarding children stay in the student dorms instead of going home to their

---

parents or guardians. Some of the teachers usually remain at the site as well. Hence, the school activity is higher this week than the other vacations.

#### **4.1.2 Observations of the property**

An important part of the fieldwork was to conduct a thorough analysis of the property. This was to understand what considerations should be taken when evaluating possible solutions for future energy supply. The data collected about the buildings at the property therefore entailed information about the architecture, including the possibility of installing systems at their roofs. Additionally, it was important to capture the electricity needs in each building. Through the user survey that was conducted in the preliminary project, some expectations about user behavior was established. However, an important purpose of the field work was to verify the correctness of these expectations.

This data was obtained by visiting each building and making observations about the appliances and systems that are currently in use. Interviews and conversations with people at the property were important in this process as well. Combined with the authors' own evaluations regarding which appliances should be accounted for if more electricity was available, the knowledge foundation about the load at the property was established. The data collected about the property during fieldwork is presented thoroughly in Chapter 5.

#### **Electricity demand**

Interview questions to understand the electricity demand at the property was established before the fieldwork. It entailed questions about which appliances that were used, the quantity of these, the frequency of usage, and the time windows. An official interview was conducted with a representative that could give thorough details about the user habits of the teachers. This interview was the foundation of time frames and appliance quantities in the Teacher's area. It also confirmed that the quantities of appliances, and some of the user habits related to this, that were used in this area was detected in the preliminary project. However, some appliances, such as a fan, a projector, and a TV, were not detected from the user survey results.

There were differences in the observed behaviour, from what was expected by the interviews and survey in the preliminary project. The activities related to school and work hours were however somewhat consistent with what was expected. However, there were large deviations in the evening activities. The appliance usage was for instance observed to last until late at night, which was not expressed during neither the interviews or the user survey. Additionally, it was seen that for instance the fan was used much more during the day than what was found from the interviews. The time frames of usage related to these appliances were therefore adjusted accordingly in this research. Daily variations in the user behavior were also observed. These observations substantiates the importance of adjusting and verifying the results from user surveys, as they do not capture these deviations and daily variations.

Another important observation was that the electricity consumption in more buildings should be accounted for. The kitchen was, for instance, previously understood to not need more electricity than what an SHS could provide. However, the author's experienced how more lighting, fans, and improved charging possibilities served its purpose. Other kitchen-related appliances, such as a fridge and a blender, were also concluded to be beneficial. Hence, the load at the property was underestimated in the preliminary project. This substantiates the value that the fieldwork had for the load estimation. All buildings at the property were registered to have some electricity needs, and will therefore be included in the master thesis.

The authors discovered that one of the best source of information when understanding people's appliance usage, and desires for future electricity supply, was to have informal conversations. It was found that it was easier for people to address their frustration over unreliable electricity supply, or their desires for a new system, when there had been established a relationship in advance. Hence, questions regarding such topics were implemented into the conversations, which resulted in valuable information. Appliances, such as blenders, and a steam iron, was for instance detected as desirable for the future. This experience emphasized the importance of adjusting the data collection method

---

to the situation, as the more formal interviews did not capture the same information.

### **Existing solutions and level of knowledge**

SHS were seen in several of the buildings at the property. Additionally, some old PV systems were observed at the Director's housing. It was very educational to see how these systems were used, as it highly illustrated the low level of knowledge at the property. Several systems had been dejected for longer periods of time. Instead of contacting relevant competence, or uninstall these systems, they were abandoned as they were. No safety measures were taken either, as several cut wires were seen laying out. Hence, it was established that it should be recommended to remove, or fix, all of these abandoned systems as a starting point before further installations are made. Easy access to relevant contact information should also be provided. This was ensured for the systems that were installed, and relocated, during the fieldwork by putting up a note with relevant numbers to call. It was confirmed with Chloride Exide that it was okay to make these numbers available.

Conversations with people at the property confirmed that they had not learned about how to maintain systems, or what to do in case of faults. This could for instance be seen when the existing installation at the Staff Room was uninstalled, as the panels were covered in dust. Additionally, they did not have a high knowledge foundation about how to utilize the current systems to its maximum by for instance charging most appliances when the solar production is at its highest. However, it was registered that they teachers had limited their evening use. This was due to frequent failures in the system when they used many appliances during hours with little or no power production. This adjusted user behavior was a result of experience-based trials, and not preventative behavior due to knowledge about how the system operates. However, it illustrates an ability to adjust and cooperate to ensure that the system can be utilized the best possible way.

These observations emphasizes the importance of knowledge sharing when new systems are installed. Knowledge about maintenance routines, and how to use the system properly, was shared during the fieldwork. However, a low level of competence must be accounted for when evaluating new solutions. It is also recommended to provide an educational program for all users of new systems, to ensure that they are operated to provide the highest possible performance.

#### **4.1.3 Local main grid**

During the fieldwork, it was found that connection points to the local main grid could be found about 300 meters away from the property. Poles had been set up close to residential buildings to supply them through single-phase wires. A transformer was observed a few hundred more meters away, connecting the single-phase wires to a three-phase distribution system. Pictures of these grid components are illustrated in Figure 17.



Figure 17: The transformer closest to Eco Moyo and the local grid with three phase wires.

It is informed that households have to pay 150 US\$ to Kenya Power as an initial fee. Kenya Power provides the needed installments, including the poles, for this fee. The consumers only pay for the power they consume. However, an additional fixed cost is included in the electricity bill. This fixed cost seemed to be a part of a pay-back process for the installation costs. However, it was unclear if it included additional fees, such as taxes, as well. Connecting to the grid did not entail any binding time.

It was expressed from local consumers that the grid is unreliable, especially during seasons with rain. Frequent blackouts were problematic as well. However, many local households found this solution to be cheaper than investing in solar systems.

## 4.2 Other experiences and considerations

Social aspects were important to consider, and learn from, during the fieldwork. Some important experiences were made when the author's relocated the existing system to the Kitchen area. When it was decided that the system was going to be moved from the Staff Room, it raised a dilemma of where it should be placed. Both the kitchen and the Staff Room were possible options. However, the teachers were already supplied by the existing system, and were provided new solutions in the Staff Room. Some dissatisfaction with only one part of the property being prioritized was registered. Hence, a reason for moving the existing system to the kitchen was to ensure that the employees that used this part of the property were included. This experience illustrated the importance of including social aspects when planning what solutions should be prioritized.

Even though it was desired to move the system to the Kitchen, the authors found it a valuable experience to observe how the installations was received once it was in use. It was registered that during the first days, not many of the employees in the kitchen utilized the new charging opportunities. Additionally, some expressed that the light installments were too bright. However, only within a few days this behavior changed. Employees in the kitchen could be seen charging their phones, and expressed their gratitude of having more electricity. The lights proved their purpose when they allowed for students to read in the evening as well. Questions about what appliances were possible to use were brought up as well. These conversations established the fundamental knowledge of what future power supply could entail.

---

Even though the relocated system ended up being a positive addition to the kitchen, the hesitance towards it was important to register. It illustrated how people find it hard to envision electricity usage that they are not used to. Additionally, it emphasized how communication is important for new installations, as it is important to include the consumer’s opinions to avoid skepticism. The authors also noted that appliances that were found fundamental to them might not be as important for people who are used to less electricity. This emphasizes the difficulty to predict future loads, and is especially important to remember when evaluating future prospects.

### 4.3 Installation of PV systems

In this chapter, the installation of the new PV system and the relocation of the old PV system will be presented.

#### 4.3.1 The local company

The installation of the new PV system installed at the property was done in collaboration with the local company Chloride Exide, based in Mombasa. Through these installations, a cooperative relationship has been established between Eco Moyo and Chloride Exide. The company has a locally owned filial in Kenya that provides solutions for batteries and renewable energy (ChlorideExide 2022a). Due to their high level of professionalism and reliability compared to other local companies, it is decided by the school management that they should deliver future installations. This cooperation with a knowledgeable and established company proposes many advantages for the future installments at the property. It can be trusted that the installments will be performed professionally. Additionally, the company has provided their contact information, ensuring that proper knowledge and help is available in case of system failures. This has not been the case for previous installations. However, this cooperation also entails some additional project boundaries for the master thesis and the further development of the electricity supply. This is because the final system solution proposal must be within the boundaries of what Chloride Exide can provide.

#### 4.3.2 New system

The installation of the new PV system at the property during field work was sponsored by EWB. The part of the fieldwork related to the electricity supply at the school site was given a budget of 35,000 NOK. Based on preliminary meetings and an inspection meeting at the site, it was decided to install a new PV system to supply the Staff Room, as this is the building with the most relevant loads. Due to better angle, azimuth, and shading on the roof of Class 5 compared to the Staff Room and the proximity between the two buildings, it was decided to place the PV panels on Class 5. Cabling was installed in the Staff Room, where the inverter and battery pack was placed. Based on inspections, calculations, conversations, and budget limits, the components are shown in Table 3 were installed by Chloride Exide. Data sheets for these components are shown in Appendix A.

Table 3: Components installed during fieldwork.

<b>Description</b>	<b>Qty.</b>	<b>Capacity</b>	<b>Brand</b>
PV module	7	450 W <sub>p</sub>	GCL
Hybrid PV Off-grid Inverter	1	3,500 W	Growatt
Tubular Gel Battery	4	200 Ah/12 V	Eastman (Chloride Solar)

The installed inverter is a hybrid inverter with integrated MPPT charge controller. The hybrid solution was chosen due to the low cost of this component compared to a system with this as two individual components. The prices for all components and installation, offered by Chloride Exide, are given in Table 4. Figure 18 shows the PV panels installed for the new PV system at Class 5 and the authors.

Table 4: Prices for components and installation of installed PV system.

Item	Unit price [NOK]
PV module	1,624
Hybrid inverter	4,804
Victron inverter	12,010
MPPT charge controller	5,338
Battery	2,577
Mounting frame	333
Installation materials	2,996
Battery rack	1,665
Installation labour	2,806
Transport	476



Figure 18: PV panels of the new PV system installed on the roof of Class 5.

### 4.3.3 Old system

A small PV system was already installed in the Staff Room a few years ago. It was decided to move this system to the kitchen. This decision was made in collaboration with Chloride Exide, and in accordance with electrical demands and conversations with users. It is, however, important to note that this system is old and unreliable. It currently provides valuable electricity to the kitchen at the property, but the remaining lifetime of this system is unknown. Especially the batteries were found to be significantly aged. Figure 19 shows pictures of all the components except the PV panels.





Figure 19: System at kitchen.

It is found that in the development of a fully reliable system at the property this system should not be included. This is due to that this system is both aged and unreliable.

---

## 5 Presentation of the property

In this chapter the data collected during areas at the property is presented. This information establishes the basis for the load profile generation presented in Chapter 6.

### 5.1 Overview of property

Figure 20 shows an illustration of the property viewed from above with assumed expansions at the property. The current buildings are marked in orange, whereas the expected expansions are marked in green. The figure also shows the significant amount of trees at the property. The buildings showed in the figure will be further presented in this chapter.

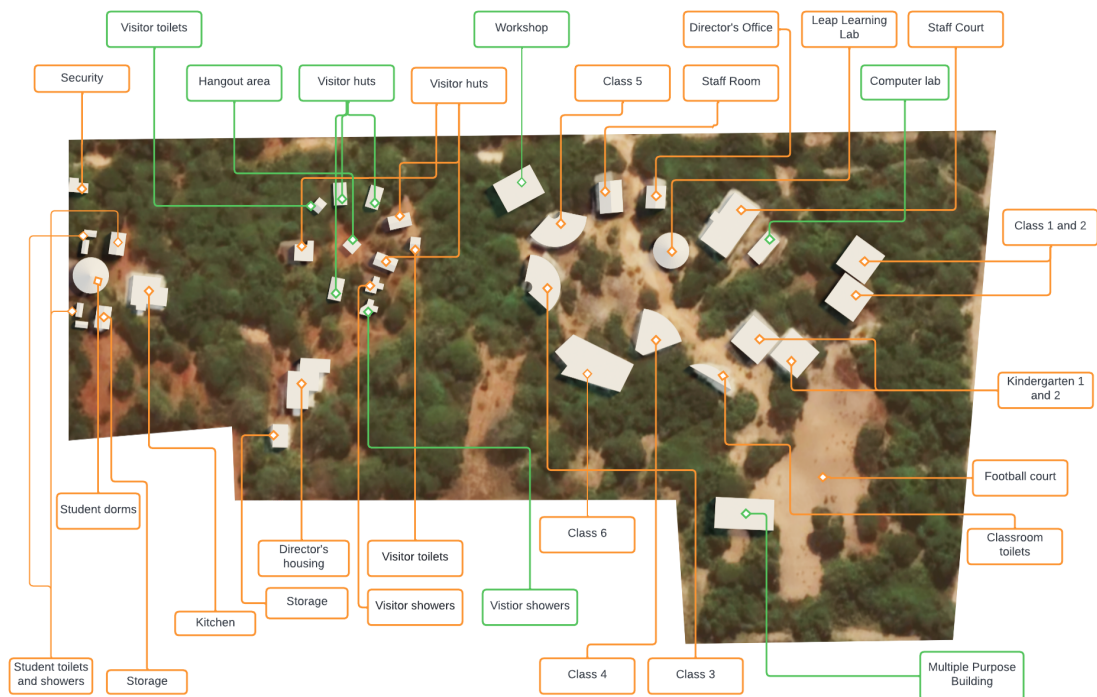

Figure 20: Overview of property.

Source: J. Lervik 2022.

### 5.2 Kitchen area

The kitchen area is placed close to the school entrance. This building offers a space for gathering the visitors, boarding students, and teachers. It is used as a place to hang out for visitors throughout the day, and they charge both laptops and phones in this building. The boarding kids uses the building when the school day is over. When the property is visited at its full capacity, four cooks are working in the kitchen to make breakfast, lunch, and dinner. Both kids and visitors usually stay at the kitchen until they go to bed between 21:00 and 00:00. Figure 21 and Figure 22 respectively shows the inside and the outside area of the kitchen.



Figure 21: Outside of kitchen.



Figure 22: Inside of kitchen.

It is possible to place PV panels on the roof of this building. After moving the old system from the Staff Room to the kitchen, new lights were installed inside the building. The new electricity supply also allows for laptop- and phone charging during the day. A storage building close to the kitchen is also a part of the kitchen area.

---

### 5.3 Student area

The student area is close to the kitchen area, and includes two student dorms, student showers, and student toilets. This area has the capacity to house 20 students, whereas 10 students can stay in each student dorm. The student area offers separate toilet and shower buildings for boys and girls. The boarding kids at the school stay at this area throughout the year, except for during the months with school vacation. Figure 23 shows the outside area of the girl dorms, while the inside of the student showers can be seen in Figure 24.



Figure 23: Area outside of the girl dorm.



Figure 24: Inside girl showers.

---

## 5.4 Director's housing area

The Director's housing area consists of a semi-detached house shared by two people working at the school. It has previously had a PV and battery system installed, and hence it is possible to use the roofs for new installations as well. A storage building is also included in this area. The activity in one of the houses is low during the day in both houses. In the evening, one of the houses is used for work after 17:00. The user behavior in these buildings do not have much deviations throughout the year. Figure 25 shows the outside of the director's housing.



Figure 25: Outside directors house.

## 5.5 Teacher's area

The area that is mostly used by the teachers is placed close to the classrooms. This area includes the Staff Room, the Staff Court, and the Director's Office. The Staff Room is used as both an office, and a hangout area, by the teachers, while the Staff Court accommodates the 6 teachers who stay at the property. The Director's Office is used by one person until the afternoon.

The Staff Room is frequently used throughout the school days. The teachers use it as an office until the afternoon, before utilizing the building as a hangout area in the evening. Both the Staff Court and the Staff Room are used as a hangout area in the weekends. However, as some teachers leave the property in the weekends, the activity in these buildings are slightly reduced from the weekends.

During the long vacations, the teaching activity ceases. Therefore, all teachers who stay at the property usually leave to see their families. The activity in the Staff Court ceases as well, while the activity level in the Staff Room is reduced accordingly. However, all activities in the Director's Office is moved to the Staff Room. Some of the appliances, such as a TV, is also used during the day.

Both the Staff Room and the Staff Court have strong enough roofs to have PV panels on them. However, it was registered during the field work that the roofs on Staff Room were fragile when people walked on them. Hence, maintenance on the panels would entail safety concerns. The same can be said for the Staff Court, if larger systems were installed. It is therefore concluded that neither of the roofs should be considered when planning for further installations. A picture of the

---

outsides of the Staff court and the Staff Room are respectively presented in Figure 26 and Figure 27.



Figure 26: Outside Staff Court.



Figure 27: Outside Staff Room.

## 5.6 Security building

Close to the school entrance, there is a security building. A guard uses this building from 19:00 to 07:00 consistently throughout the year. Figure 28 presents the outside of this building.



Figure 28: Side views of security building.

## 5.7 Visitor area

The visitor area currently consists of three visitor huts, a shower area, and a common toilet. Two of the visitor buildings are close to identical, and houses 6 people each. The third building houses 3 people. It also has a separate shower and toilet. The visitor activity is sporadic, and does mostly consist of volunteers. The visitor huts are supplied by SHSs that allow for phone charging and some light. None of the current buildings can have larger system installations on them.

The visitor area does currently not provide an area for visitors to hang out, and the activity in this area is therefore mostly related to morning activity and activities before the visitors go to sleep. The visitors hang out in the kitchen area instead. Laptops are charged there as well. Figure 29 presents the identical visitor huts and the toilet, whereas Figure 30 shows the third visitor hut.



Figure 29: Overview of visitor area.



Figure 30: Outside and inside sleeping area main hut.

## 5.8 Classroom area

The classroom area entail all classrooms at the property, i.e. Class 1 to 6 and two kindergarten buildings, Kindergarten 1 and 2. Most classrooms can have systems installed on them. They are also built to ensure good natural ventilation and light conditions. However, it was noticed that some lights and fans could be a positive contribution to improve the teaching environment. When there is regular activity at the school, all classrooms are used between 07:00 and 15:00 in the weekdays. Some after-school activities occur as well, usually until 17:00. None of the classrooms are used in the vacations. Class 1 and Class 2 are close to identical to the kindergartens. Class 1



---

is presented in Figure 31. Class 3, 4 and 5 are close to identical as well. The inside and outside of Class 5 is presented in respectively Figure 32 and Figure 33.



Figure 31: Outside class 1.



Figure 32: Class 5.



Figure 33: Inside class 5.

## 5.9 The Leap Learning Lab

The Leap Learning Lab is a classroom that facilitate learning through devices and technology such as tablets. 15 tablets are currently charged at the Staff Court, but this quantity is expected to be increased to 20 tablets. The teaching schedule is identical to the other classrooms. No fans or lights are currently used in this building, but it is registered that it could be beneficial to have some of these appliances in this building as well. It is not possible to install a large system on the roofs of this building. Figure 34 and Figure 35 respectively present the outside and the inside of the Leap Learning Lab.



Figure 34: Outside Leap Learning Lab.



Figure 35: Inside Leap Learning Lab.

## 5.10 Possible future expansions

Eco Moyo has future needs with regard to facilities that can facilitate teaching of computer skills, practical subjects, as well as more space for visitors, teachers, and arenas for meetings with parents and villagers (EWB et al. 2020). As presented in Chapter 1.2, one of the objectives of the master thesis is to propose solution for electricity supply that accounts for future development and expansions at Eco Moyo. The strategic plan proposes several possible future building projects at the property. Conversations with a representative from the Eco Moyo Administration inform that the projects that are expected to happen within one or two years can be summarized as follows (Sanner 2022):

- Computer lab
- Multi-purpose building
- Workshop
- Extended visitor area

Because these projects are prioritized for future expansions of the property, it is considered reasonable to assume that these buildings are to be supplied by the further expansion for energy supply at Eco Moyo. Hence, they will be accounted for in the load profiles, and the system proposals that will be presented in this master thesis. Each project will be further elaborated in this chapter.

### 5.10.1 Computer lab

One of the objectives of the school is to introduce computer classes for all students (EcoMoyo 2022b). The computer lab that is presented in the strategic plan can house 30 students. It will

---

serve educational purposes, and is assumed to be used in the same way as the other classrooms. Additionally, it is desirable that the laptops in the building could be utilized by the local community. This could for instance entail training of adults in computer usage. Hence, there is expected to be some usage of this building after school and during the vacations as well.

It is communicated that the Computer lab should be placed close to the other class rooms. The material storage close to the Staff Court has been used as a classroom for Class 1 due to lack of space. However, as new classrooms have been built, this space has become available to be utilized for other purposes. To avoid unnecessary expansions at the property, it is suggested that the new computer lab is placed in this area. However, a new building would have to be invested in, as the computers should be able to be locked safely inside. This is not possible with the current architecture. The explained location will be assumed in this project.

### **5.10.2 Expanded visitor area**

As part of the vision of a financially independent Eco Moyo, it is desirable that the visitor area and the school facility are used for other income-generating purposes. Volunteers show interest in paying to stay at the school's visitor center while assisting with volunteer work at the school. Further, students from other countries or cultures can stay at the school's visitor area to carry out cultural exchange projects. This is particularly relevant for folk high schools. The visitor area can also be used as a base camp for tourists who want to visit the nature reserve nearby. Currently, most visitors are expected to come from Norway. It has therefore been expressed that the seasons of high visitor activity will be from the Norwegian fall- and Easter break (Sanner 2022). This entails that the visitor huts can be expected to be fully booked for several months of the year, whereas only a few visitors are assumed to be accommodated during other months. In order to be able to accommodate more visitors for such types of visits, it is desirable to expand the visitor area.

### **5.10.3 Multi-purpose building**

A multi-purpose building that has a capacity of 150 people is proposed in the strategic plan (EWB et al. 2020). This building should facilitate for large gatherings for both students and the local community. Additional conversations with the Eco Moyo administration present that the building could be used for gym classes during the day, and for other gatherings in the afternoon and in the weekends (Sanner 2022). Classroom schedule is therefore expected in the daytime during weekdays. Additionally, the local community is expected to use it during the weekends and in the afternoon. Fans, lights, and charging opportunities should therefore be accounted for in this building. It is planned to place this building close to the football court.

### **5.10.4 Workshop**

One of the objectives of the school is to encourage the development of practical skills and engage students in creative work. The Workshop that is presented in the Strategic plan can facilitate for such activities. It should have enough space for 30 students (EWB et al. 2020).

The Workshop is a project that will be prioritized in the nearest future. The vision for this building is that it can be used as a space for students to work with several forms of creativity. This could entail anything from painting to building furniture. It is also mentioned that it is a possibility of including some Leap Learning Lab based teaching in these buildings as well. The mentioned activity are expected to be a part of the school schedule, and hence have the same activity as the other class rooms. However, it is also desirable to be able to borrow appliances to the local community, or have additional after-school activities in this building. Hence, the building is expected to be used in the evening as well.

There has also been expressed a need for the care taker of the school to be able to do maintenance work by using tools that currently require that a diesel generator is used. The mentioned tools are a drill, circular saw, and an angle grinder. Hence, the Workshop will be adjusted for such

---

maintenance work as well. Due to safety concerns, it is not expected that these tools will be used for educational purposes. However, they are expected to be occasionally used by the care taker, or borrowed by the local community in the afternoon or in the weekends.

The Workshop should be close to the classroom area. However, it could be beneficial to place it close to the road that extends from the entrance of the property. This is to allow for easier access for local people who wants to utilize the building as well. Hence, it is assumed that the Workshop is placed close to Class 5.

---

## 6 Establishing load profiles in RAMP

To ensure that the system proposals are adjusted to the electricity demand at the property, load profiles have to be established. The bottom-up stochastic model RAMP, which was presented in Chapter 3.6.1, is used to establish minute based, annual load profiles that reflects the electricity demand at Eco Moyo. This choice is based on the findings from the research performed in the preliminary project.

The stages that are completed to obtain the load profiles are presented in Figure 36. Data collection from the fieldwork, conversations with representatives from the school, and additional assumptions have established the foundation for the model input for each building at the school. Relevant combinations of buildings will be included in model inputs for stochastic model generation of their respective load profiles. This results in several annual load profiles that can be used in the PVsyst simulations. The model input is adjusted for the different time periods throughout the year to account for the seasonal variations.

This chapter will present the model input that is established. Load profiles for relevant buildings will be included for illustrative purposes as well. However, the resulting load profiles that are used in PVsyst are presented in Chapter 7.

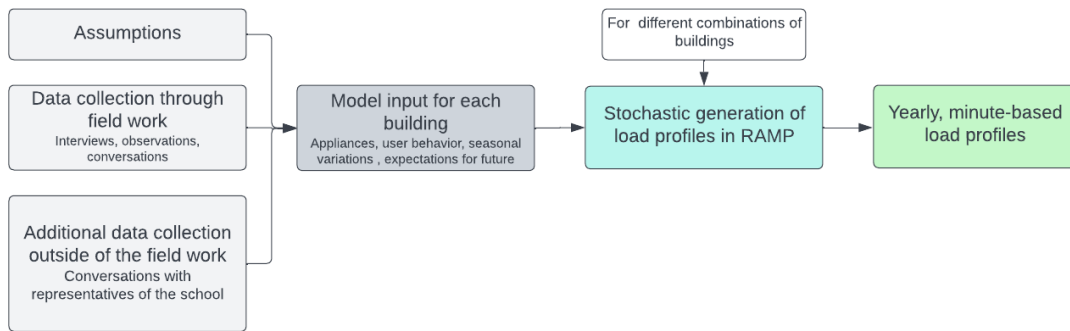

Figure 36: Methodology to obtain the load profiles of the property.

### 6.1 RAMP model input

In line with the required input data presented in Table 1, building types, Users, Appliances, and parameters related to these, must be provided as model inputs. It is decided that each building type represents a type of building at the property. A User thereby corresponds to a building of that type. The building types and Users will therefore be referred to as building types and buildings instead further in this master thesis.

#### 6.1.1 Accounting for seasonal variations

To be able to capture the varying electricity demand throughout the year, the model inputs are adjusted for different time periods. The main contributing factors to seasonal variations that should be accounted for in the load profiles are the school vacations and the number of visitors at the property. Additionally, the user behavior related to some of the appliances are assumed to be adjusted to temperature variations. Time periods are therefore defined based on variations in climate, scheduled school vacations and visitor activity. After defining the model input for these time periods, annual load profiles are generated by aggregating the periods into a complete year.

Average monthly temperatures are considered when defining seasonal variations based on the climate. The temperature is used as the main parameter because it is assumed to have the largest affects on user behavior. The seasons are categorized into hot, warm, and cold season, determined

by the average monthly temperature. This is in line with the season categories that are defined for the fridge cycle modulation in (Lombardi et al. 2019). The temperatures are assumed to influence the usage patterns of both fans and fridges, whereas the remaining appliances are assumed to be unaffected by temperature variations. Based on the weather data presented in Chapter 3.1.2, temperature intervals are defined for the different categories, as presented in Table 5.

Table 5: Temperature intervals established for the seasons defined by average monthly temperatures.

Season type	Temperature [°C]
Hot	27.1 - 28.5
Warm	25.1 - 26.3
Cold	24.1 - 24.9

An overview of the time periods that are used to construct the load profile is presented in Table 6, with columns that present the seasonal variations related to the different periods. The temperature intervals are used to categorize the climate seasons in Table 6. It should be noted that it is assumed that the indoor temperature is approximately equal to the outdoor temperature. As can be seen from the table, electricity usage during vacations and mid-term vacation are separated from periods with regular school as well. The time periods with a fully booked visitor area is referred to as periods with high visitor activity, whereas the remaining time periods are denoted by low visitor activity.

Table 6: The time periods the model input is adjusted to in order to establish annual load profiles.

Start date	End date	Climate season	School activity	Visitor activity
January 1	January 31	Hot	Regular	High
February 1	February 7	Hot	Mid-term vacation	High
February 8	March 31	Hot	Regular	High
April 1	April 30	Hot	Vacation	High
May 1	May 31	Warm	Regular	Low
June 1	July 31	Cold	Regular	Low
August 1	August 31	Cold	Vacation	Low
September 1	September 23	Warm	Regular	Low
September 24	October 31	Warm	Regular	High
November 1	November 15	Hot	Regular	High
November 15	December 31	Hot	Vacation	High

### 6.1.2 Appliances

Model input related to the appliances have to be established as well. Some of these appliances are currently in use, whereas others are included in the load profile because they are expected to be used when the electricity supply is improved. All fridges, most fans, and the printer, are, for instance, included as expected future appliances. Additionally, the number of appliances, such as lights, are increased in most buildings. This is based on the author's observations during the fieldwork, in addition to conversations with people at the property about their electricity needs.

Several parameters must be given as input for each appliance that is included in the load profiles. It is decided to keep some of the parameters related to the Appliances consistent, regardless of the building types they are assigned to. Table 7 presents an overview of these.

Table 7: Appliance parameters that are independent of the building type they are related to.

Input data		Description
P	[W]	The power absorbed by a given appliance.
t_min	[min]	Minimum time the appliance is kept on after switched on.
$\delta_{t\_min}$	[%]	Random variability applied to t_min
$\delta_{windows}$	[%]	Random variability applied to time windows.

Source: Lombardi et al. 2019, p.435

Other parameters must be specified for each appliance, depending on the building type they are related to. These are presented in Table 8. The variable name that will be used further in the project is defined in the right column. Other parameters, for instance related to weekend behavior, or duty cycles can be defined as well. However, these are not defined for all appliances, and will be introduced for the relevant cases.

Table 8: The parameters that are specific to the appliance in each building type.

Input data in RAMP		Variable name	
m	[qty.]	m	[qty.]
tot_use	[min]	Usage	[min]
use.frames	[-]	Window	[-]
Frequency	[%]	Frequency	[%]

The appliances accounted for in the load profiles are presented in Table 9. The consistent values of their respective parameters are included as well. The values of  $\delta_{t\_min}$  and  $\delta_{frames}$  are extracted from the input files provided by the source-code of the model (Lombardi et al. 2022). Appliances that are the same, or similar, to the objects created in this source-code get the corresponding values. The same procedure is used to determine  $t_{min}$ . The sources of the power ratings are presented in Table 49 in Appendix B.

Table 9: Appliances assumed at the property.

Appliance	Power [W]	t_min [min]	$\delta_{frames}$ [%]	$\delta_{t\_min}$ [%]
Phone	7	5	20	35
Laptop	60	5	10	35
Fan	50	5	20	35
Indoor LED	9	5	20	35
Outdoor LED	9	5	20	35
Projector	220	5	10	35
Fridge	150	5	0	0
Blender	400	5	10	35
Tablet	15	5	10	35
Printer	150	5	10	35
Radio	5	5	10	35
Shaving machine	15	5	10	35
Steam iron	1000	5	10	35
Decoder	10	5	10	35
TV	60	5	10	35
Small speaker	10	5	10	35
Medium speaker	50	5	10	35



---

### 6.1.3 Adjustments made to account for varying temperatures

The parameters that are given as model input to adjust the user behavior of the fridges in the different seasons will be presented in this chapter.

#### Seasonal adjustments for the fridge

It is decided to use the same modelling procedure for the fridge as presented in (Lombardi et al. 2019). This entails to account for room temperatures and user activity when simulating their duty cycles. The cycles can be categorized into standard, intermediate, and intensive. These categories reflect the extensiveness, i.e. frequency of the fridge being opened, of the user habits. The cycles are related to different time windows that are associated with certain behavior. It is for instance assumed that the fridge is more actively used during the day. The duty cycles that are presented in Table 10 was constructed for all fridges (Lombardi et al. 2019).

Table 10: Seasonal based duty cycles for fridge.

Season type	Standard	Intermediate	Intensive
Hot	00:00-04:59	05:00-07:59	0800-20:00
	20:01-00:00	-	-
Warm	00:00-04:59	05:00-09:39	09:40-18:00
	18:01-00:00	-	-
Cold	00:00-04:59	08:00-20:00	-
	20:01-00:00	-	-

#### Seasonal adjustments for the fan

During the cold periods, the intensity of the user patterns of the fan is assumed to be reduced. This entails reducing total time of use during the day. The time windows are adjusted accordingly for most fans at the property during this season as well. However, because the temperatures are high even in the cold periods, the usage patterns are not changed in any other ways. The fans are, for instance, assumed to be used during the night in the buildings that accommodate people during the cold season as well. The difference between the warm and the hot season are assumed small enough to not affect the user patterns of the fans. Hence, it is assumed to be the same for the warm and the hot seasons.

## 6.2 Load modelling

The parameters that are given as the model input when simulating load profiles of the different buildings at the property will be presented in this chapter. Resulting load profiles will be presented for illustrative purposes as well.

### 6.2.1 Current visitor area

The current visitor area consists of three visitor huts, whereas two of them are close to identical. The building type related to these huts are defined as Visitor hut type 1 (VH1). The third visitor hut is, on the other hand, referred to as Visitor hut type 2 (VH2) due to some differences, such as the number of visitors staying at the hut. All building types in the current Visitor area is presented in Table 11.  $n$  denotes the number of buildings of the types that is currently at the property.

---

Table 11: Building types for the current visitor area.

Building type	Acronym	n [qty.]
Visitor hut type 1	VH1	2
Visitor hut type 2	VH2	1
Visitor showers	VS	1
Visitor toilet	VT	1

An overview over which appliances are currently in use, and which are expected, and hence included in the model input, are presented in Table 12. As it is desirable to ensure that the visitors can be more self-sufficient when they visit the property, fridges are included in all buildings. Additionally, it was registered during the fieldwork that it would be beneficial to install fans in the visitor huts as well.

Table 12: Appliances assumed in the visitor area.

Appliance	Current	Expected
Phone	X	X
Laptop	-	X
Fan	-	X
Indoor LED	X	X
Outdoor LED	X	X
Small speaker	X	X
Fridge	-	X

The parameters of the appliances in VH1 during hot season is presented in Table 13. All parameters, except the quantity of the appliances, denoted as  $m$ , is identical in VH2. The appliances accounted for in VH2 are presented in Table 52 in Appendix B. It should be noted that even though visitors are assumed to have a laptop each, the charging of half of these is accounted for in the kitchen area due to observations of user habits during the field trip. Hence, not all laptops are included in the model input for the visitor huts. The small speaker is only assumed to be used 50 % of the days, as it does not have to charge as often as the other appliances. The time window of the outdoor lights accounts for behavior during the night, as the visitor toilets might be used. It is also assumed that the user behavior is the same throughout the week, as the visitors do not rely on the school schedule.

The input data related to the VH1 and VH2 is adjusted for the cases defined as high and low visitor activity. When the visitor activity is high, it is assumed that the visitor huts are accommodating at its maximum capacity. During the rest of the year, it is assumed that only one VH1 accommodates a total of three visitors. The number of phones are then reduced to be the same as the number of visitors. The number of fans, and the frequency of speaker usage is reduced as well. Other model input stays unchanged. The appliances adjusted in VH1 during periods with low visitor activity are presented in Table 53 in Appendix B.2.

Table 13: Appliances assumed in the Visitor hut type 1 during the hot season with high visitor activity.

Appliance	m [qty.]	Usage [min]	Window 1	Window 2	Frequency [%]
phone	6	120	07:00-00:00	-	100
Laptop	3	240	07:00-00:00	-	100
Fan	2	540	12:00-14:00	21:00-07:00	100
Indoor LED	2	120	06:00-07:00	19:00-00:00	100
Outdoor LED	1	60	19:00-07:00	-	100
Small speaker	1	60	07:00-00:00	-	50
Fridge	1	1440	00:00-00:00	-	100

Figure 37 presents a daily load profile of pne VH1 during periods with varying visitor activity. As can be seen from the figure, the difference in power consumption can almost be considered negligible. Because the appliances that are adjusted only have a small power consumption, this is expected. The electricity consumption is largest during the middle of the day for both load profiles. This can reflect the fan, which is assumed to be used during these time periods. The random charging of the other appliances can contribute to the electricity usage as well. The duty cycles of the fridge is apparent when other appliances are not in use.

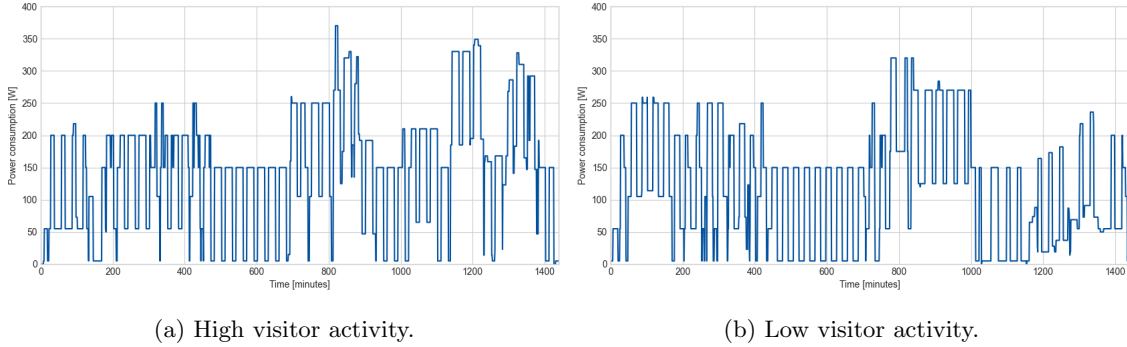

Figure 37: Daily minute based load profiles for VH1 with varying visitor activity during a warm season.

## 6.2.2 Kitchen area

The kitchen area consists of the building types that are presented in Table 14. For simplicity, their acronyms will not be used in further description. The appliances that are included in the load profiles of the kitchen are based on what is currently used with the existing system. Additionally, a fridge, fans, and a blender is added based on conversations with the people using the kitchen, and observations during the fieldwork. An overview of all appliances is presented in Table 15.

Table 14: Building types at the kitchen area, and the number of Users, i.e. buildings, of the type,  $n$ .

Building type	Acronym	n [qty.]
Kitchen	K	1
Storage	Stor <sub>K</sub>	1

Table 15: Appliances included in the load profile of the kitchen area.

Appliance	Current	Expected
Phone	X	X
Laptop	X	X
Fan	-	X
Indoor LED	X	X
Outdoor LED	X	X
Small speaker	X	X
Fridge	-	X
Blender	-	X

The kitchen activity is related to the cooking of meals for visitors, teachers and the boarding students. Some appliances, such as the fan and the speaker is therefore adjusted to be used during lunch hours and when the visitors and students hang out during dinner and in the evening. Other appliances are used throughout the day. The blender is set to have a lower usage frequency than other appliances, as the user habits related to it is unknown, and assumed to be occasional. The percentage value is found for a similar appliance in the RAMP source-code (Lombardi et al. 2022). The parameters related to the appliances that are used in the kitchen during the hot season with high visitor activity is presented in Table 16. The only appliances used in the storage, are three lights.

The laptops that the visitors are assumed to charge at the kitchen are included as well. Assuming that all visitor huts are visited at their full capacity, and that half of these charge in the kitchen, this corresponds to around 8 laptops. These appliances highly affect the power consumption in the kitchen area. Because the visitors are independent of the school schedule, the load profiles are consistent throughout the week. For the same reason, the user behavior in the kitchen is not adjusted to the vacations. However, the quantity of laptops and phones are reduced to respectively 4 and 2 when the visitor activity is low.

Table 16: Appliances assumed in the Kitchen during the hot season with high visitor activity.

Appliance	m [qty.]	Power [W]	Usage [min]	Window 1	Window 2	Frequency [%]
Phone	8	7	120	07:00-19:00	-	100
Laptop	8	60	240	07:00-00:00	-	100
Fan	3	50	420	12:00-15:00	19:00-00:00	100
Indoor LED	8	9	300	06:00-07:00	19:00-00:00	100
Outdoor LED	1	9	120	06:00-07:00	19:00-00:00	100
Small speaker	1	10	60	12:00-15:00	19:00-00:00	100
Fridge	1	150	1440	00:00-00:00	-	100
Blender	1	400	30	07:00-19:00	-	33

Figure 38 presents daily, minute-based load profiles for scenarios with high and low visitor activity during a warm season. Figure 38a and Figure 38b respectively represent periods with high and low visitor activity.

As can be seen from the figure, the difference is most notable in the middle of the day. The power consumption is significantly higher during the day when there are many visitors at the property. During the rest of the day, the power consumption is similar. Periods where there is little activity in the kitchen area is reflected by the periods where duty cycles of the fridge is the only load. The evening activity in the kitchen is reflected in an increased electricity usage in both load profiles. However, the random variability related to time windows is apparent in the evenings, as power consumption is registered earlier in the evening in Figure 38b.

The daily profile with high visitor activity have a peak consumption during lunch hours, whereas

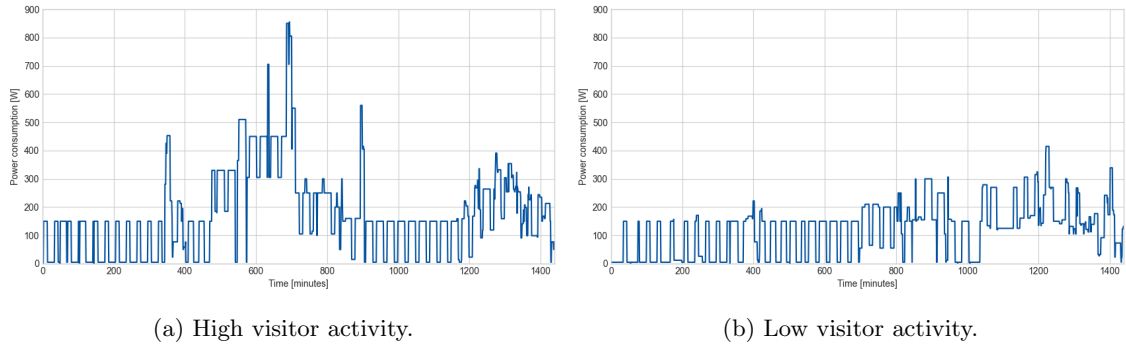

Figure 38: Daily minute based load profiles for the kitchen with varying visitor activity during a warm season.

the peak is in the evening for the day with less visitor activity. These are registered to be just over 850 W and 410 W for the high and low visitor activity, respectively. Hence, the peak consumption more than doubles when more laptops and phones are included in the load profile with more visitors. However, the large differences could also possibly reflect that the blender is only used in Figure 38a.

### 6.2.3 Teacher’s area

The Teacher’s area is defined to include the building types presented in Table 17. Many appliances in these buildings have user behavior that depends on the school schedule. Hence, several considerations are made when establishing the objects related to the Teacher’s area. The appliances included in the load profiles are presented in Table 18. The printer and the fridge are new additions to the SR based on observations and conversations in the fieldwork. The steam iron is added to the SC for the same reason.

Table 17: Building types at the teacher area.

Building type	Acronym
Staff Room	SR
Staff Court	SC
Director’s Office	Office

Table 18: Appliances included in the load profiles for the Teacher’s area.

Appliance	Current	Expected
Fan	X	X
Small speaker	X	X
Medium speaker	X	X
Indoor LED	X	X
Outdoor LED	X	X
Fridge	-	X
Projector	X	X
Shaving machine	X	X
Phone	X	X
Laptop	X	X
Printer	-	X
TV	X	X
Decoder	X	X
Steam iron	-	X

---

### Accounting for weekly variations

To account for changes in behavior between behavior in weekends and weekdays, the model input differentiates between the week. Especially the SR has variations throughout the days of the week. Work-related appliances, such as laptops, have time windows that adjust to the teachers' work hours. Afterward, several appliances, such as the TV, are used when the teachers use the SR in the evening. During the weekends, the number of appliances is reduced to account for the teachers that leave the property. It is also assumed that work-related appliances, such as the printer and most laptops, are not used during the weekends. Table 19 presents the appliance usage that is consistent throughout the week in the SR, while Table 20 includes the additional appliances that are used during the weekdays. Table 21 presents the model input for appliances used during the weekends. Interviews and observations of user behavior establish the foundation of the defined time windows.

Table 19: Appliances assumed in the SR during the hot season throughout the week.

Appliance	m [qty.]	Usage [min]	Window 1	Window 2	Frequency [%]
Fan	2	600	12:00-00:00	-	100
Small speaker	1	60	07:00-21:00	-	50
Medium speaker	1	60	07:00-21:00	-	50
Indoor LED	2	300	06:00-07:00	19:00-00:00	100
Outdoor LED	2	120	06:00-07:00	19:00-00:00	100
Fridge	1	1440	00:00-00:00	-	100
Projector	1	60	07:00-19:00	-	50
Shaving machine	1	60	16:00-19:00	-	20

Table 20: Additional appliances assumed in the SR during the weekdays in the hot season.

Appliance	m [qty.]	Usage [min]	Window 1	Window 2	Frequency [%]
Phone	8	120	07:00-19:00	-	100
Laptop	8	120	07:00-19:00	-	100
Printer	1	30	07:00-19:00	-	50
TV	1	360	16:00-00:00	-	100
Decoder	1	360	16:00-00:00	-	100

Table 21: Additional appliances assumed in the SR during the weekends in the hot season.

Appliance	m [qty.]	Usage [min]	Window 1 [-]	Window 2 [-]	Frequency [%]
Phone	4	120	07:00-19:00	-	100
Laptop	4	120	07:00-19:00	-	100
TV	1	360	10:00-00:00	-	100
Decoder	1	360	10:00-00:00	-	100

### Accounting for vacations

Because the activity in the SC and the Office ceases during the vacations, these building types are not included in the load profile during these periods. The SR is limited to only being used by a few people. The appliance usage is therefore reduced accordingly. As observed during the fieldwork, most appliances related to the school schedule are still in use. However, the number of appliances and usage patterns are adjusted. Table 60 in Appendix B.3 presents the model input for the SR during vacations.

Figure 39 presents several daily load profiles for the SR. Figure 39a, Figure 39b, and Figure 39c respectively present the load during the cold, warm, and hot season. Figure 39d presents the power consumption during a vacation in the hot season. As seen from the Figures, the load profiles do not vary much for the different seasons when there is regular school. However, it can be seen from Figure 39d that the power consumption is larger and lasts longer during the daytime. This could reflect an increased usage of the fans. The peaks occur in the afternoon and evening during the cold and the warm seasons, respectively. This reflects the after-school activity. During vacations, the power consumption stays consistently low. There are no prominent peaks as fewer appliances are in use. However, some evening activity can still be detected.

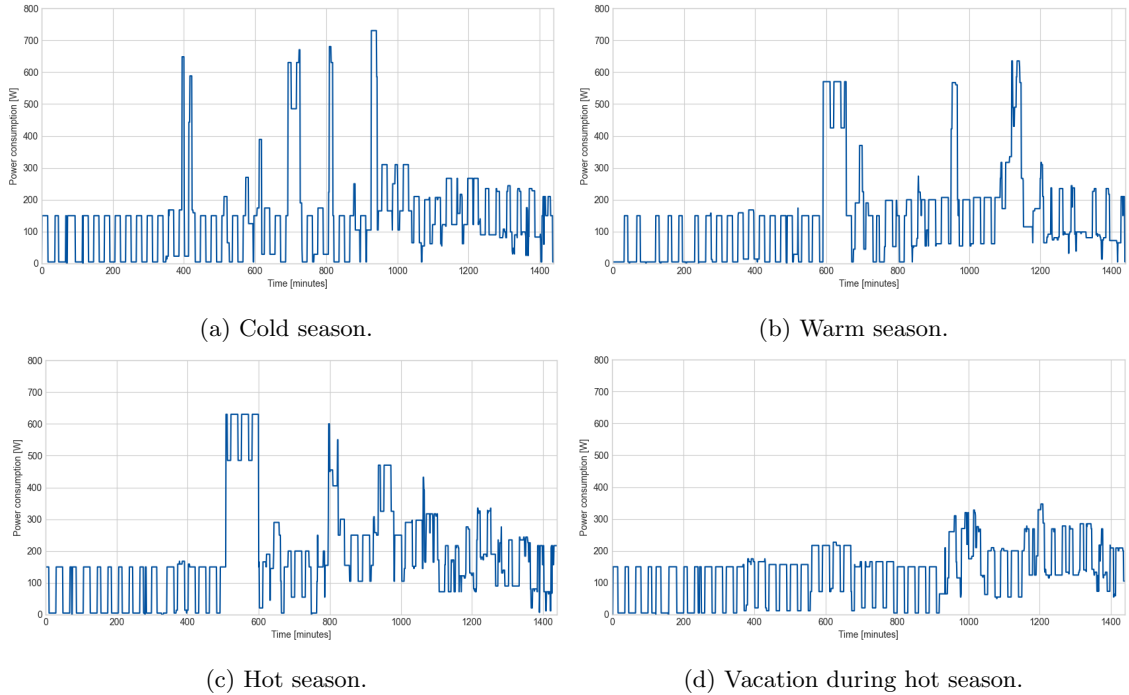

Figure 39: Daily minute based load profiles for SR during different seasons.

#### 6.2.4 Classroom area

The classroom area entails all classrooms at the property. The corresponding building types are presented in Table 22. Due to the almost identical architecture, Class 1 and Class 2 are categorized to be Users within Classroom type 1 ( $Class_{t1}$ ). Similarly, Class 3, 4 and 5 are Users within Classroom type 2 ( $Class_{t2}$ ). The same applies to PP1 and PP2, which are categorized as PP.

Table 22: Building types at the classroom area, and the number of Users, i.e. buildings, of the type,  $n$ .

Building type	Acronym	n [qty.]
Classroom type 1	$Class_{t1}$	2
Classroom type 2	$Class_{t2}$	3
Class 6	$Class_6$	1
Kindergarten	PP	2
Leap Learning Lab	LL	1
Classroom toilets	CT	1

The architecture of all classrooms allows for good ventilation and natural lights, and there are currently no appliances in use in these buildings. However, it was registered during the field trip

that installing some lights and fans in the classrooms could be beneficial to improve the learning conditions, especially during the hot seasons. The appliances that are included in the load profiles are, therefore, as presented in Table 23.

Table 23: Appliances included in the load profiles of the classrooms.

Appliance	Current	Expected
LED Indoor	-	X
Fan	-	X

Because the classrooms only are in use during the weekdays, the model input related to these buildings is not included for weekends. The time windows are adjusted to suit the school schedule, which usually lasts from 07:00 to 15:00. However,  $\text{Class}_{t1}$  are used for activities, such as drama- and taekwondo classes, after school. Therefore, the time windows are expanded to 17:00 in these classrooms, as presented in Table 24. Even though the time windows differ from the classrooms that are not used for other activities and have shorter time windows, this table is representative of the appliances used in most classrooms. The time windows used in  $\text{Class}_{t1}$  and  $\text{Class}_6$  are presented in Appendix B.4. The model input for the cold season and the other building types are also included in Appendix B.4. None of the building types in the Classroom area are included in the load profile during the vacations, as all school activity is closed during these periods.

Table 24: Appliances assumed in  $\text{Class}_{t1}$  in the hot season during the weekdays.

Appliance	m [qty.]	Usage [min]	Window 1	Frequency [%]
Light	4	420	07:00-17:00	100
Fan	2	420	07:00-17:00	100

### The Leap Learning Lab

The Leap Learning Lab (LLL) is the only building type in the classroom area that includes the charging of tablets. Currently, all tablets are charged in the SR. However, as it is more convenient to charge them where they actually are used, they are included in the load profile of the LL as this a desirable solution for the future.

The total quantity of tablets that are used in the LL is set to the expected value of 20. All tablets are charged two times a week, whereas half of them are charged at the same time. This entails that 10 tablets are charged simultaneously on four of five weekdays. The number of appliances,  $m$ , is therefore set to 10 to simulate the charging behavior throughout the week. These are set to be charged 80% of the weekdays (i.e. 4 days), and hence, the *frequency* parameter is set to this value. Additionally, it is defined that these appliances always are charged together. Hence, the *fixed<sub>num</sub>* parameter is adjusted accordingly.

Table 25: Appliances assumed in the Leap Learning Lab in the hot season during the weekdays.

Appliance	m [qty.]	Usage [min]	Window 1	Window 2	Frequency [%]
Tablets	10	120	10:00-16:00	-	80
Fan	2	300	07:00-15:00	-	100

Figure 40 presents load profiles of the LL for the different seasons. As can be seen from the figure, the random variability entails that not all tablets are charged simultaneously. This can be seen from the peaks, as there is not just one significant peak but some variations during the time frame defined in the model input. Charging routines might be changed or more varied if they can



be charged in the LL instead of the SR. Hence, it is concluded that the load profile represents potential charging behavior. Due to the fan, there is more consumption during the daytime during both the warm and the hot seasons. The weekly load profile in Figure 40d presents how setting the frequency parameter to 80 % ensures that the laptops are charged for four days. This can be seen from the four peaks that are present throughout the weekdays. It can also be seen how the weekend is accounted for, as there is no power consumption during the last days of the week.

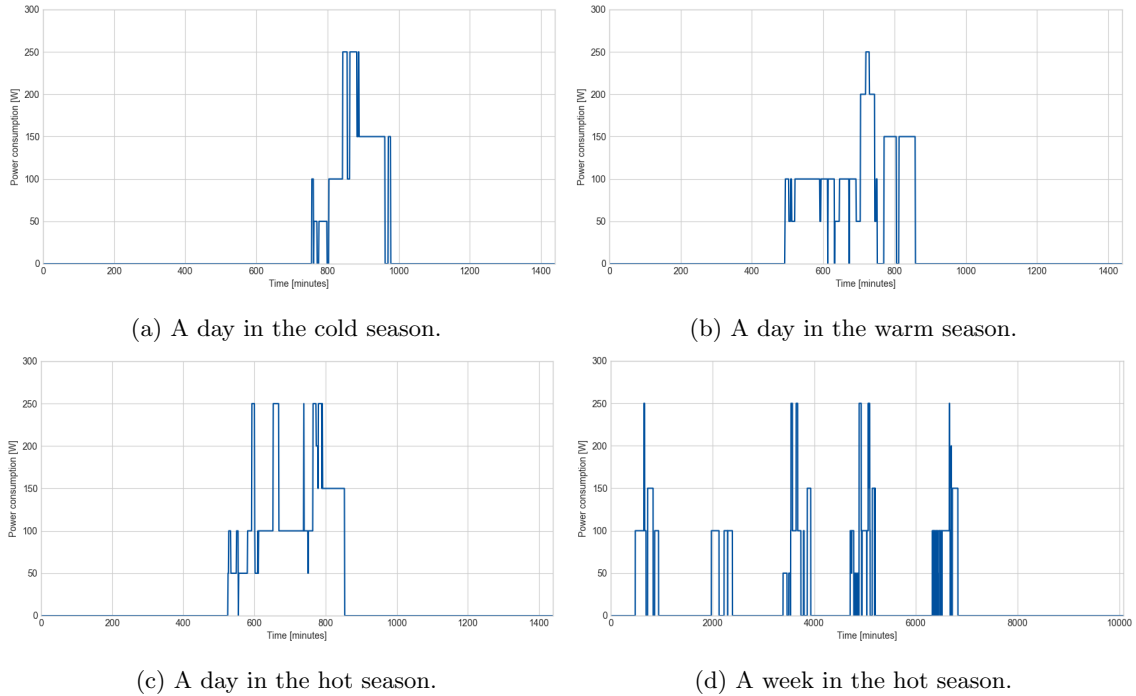

Figure 40: Daily minute based load profiles for the LLL during the different seasons.

### 6.2.5 Director's housing area

The area with Director's housing include two residential buildings that houses one person each. A storage building nearby is included as well. Their building types are presented in Table 26. Based on observations during the fieldwork, and interviews, not many seasonal variations are accounted for in these buildings, as the user behavior stays consistent.

Table 26: Buildings related to the Director's housing, and the number of Users, i.e. buildings, of the type,  $n$ , in the different scenarios.

Building type	Acronym	n [qty.]
Residential building 1	RB <sub>1</sub>	1
Residential building 2	RB <sub>2</sub>	1
Storage	Stor <sub>Dir</sub>	1

The appliances included in the Director's housing area are presented in Table 27. Fridges and fans are included to make the homes more self-sufficient. A fridge is already present in the RB 2 but is currently not in use because there is not a large enough system to supply it. However, it substantiates the choice of including it in the load profile.

Table 27: Appliances included in the load profiles for the Director’s housing.

Appliance	Current	Expected
LED Indoor	X	X
LED Outdoor	X	X
Fan	-	X
Phone	X	X
Laptop	X	X
Fridge	-	-

Table 28 and Table 75 respectively presents the parameters related to the appliances accounted for in RB<sub>1</sub> and RB<sub>2</sub>. The only appliances accounted for in the Stor<sub>Dir</sub> are some LED lights.

Table 28: Appliances assumed in RB<sub>1</sub> during the hot season.

Appliance	m [qty.]	Usage [min]	Window 1	Window 2	Frequency [%]
LED Indoor	3	420	06:00-07:00	17:00-00:00	100
LED Outdoor	1	60	19:00-07:00	-	100
Fan	1	600	17:00-07:00	-	100
phone	1	120	07:00-00:00	-	100
Laptop	1	240	07:00-00:00	-	100
Fridge	1	1440	00:00-00:00	-	100

Table 29: Appliances assumed in the RB<sub>2</sub> during the hot season.

Appliance	m [qty.]	Usage [min]	Window 1	Window 2	Frequency [%]
LED Indoor	6	300	06:00-07:00	19:00-00:00	100
LED Outdoor	3	60	19:00-07:00	-	100
Fan	2	540	21:00-07:00	-	100
phone	1	120	07:00-00:00	-	100
Laptop	1	120	13:00-21:00	-	50
Fridge	1	1440	00:00-00:00	-	100

Figure 41 illustrates the electricity usage during the different seasons. The duty cycle of the fridge can be seen to be dominating during the day, whereas the activity in the houses increases in the evening. The fan usage during the night is reflected as well. As expected, the load profiles are close to identical for the different seasons.

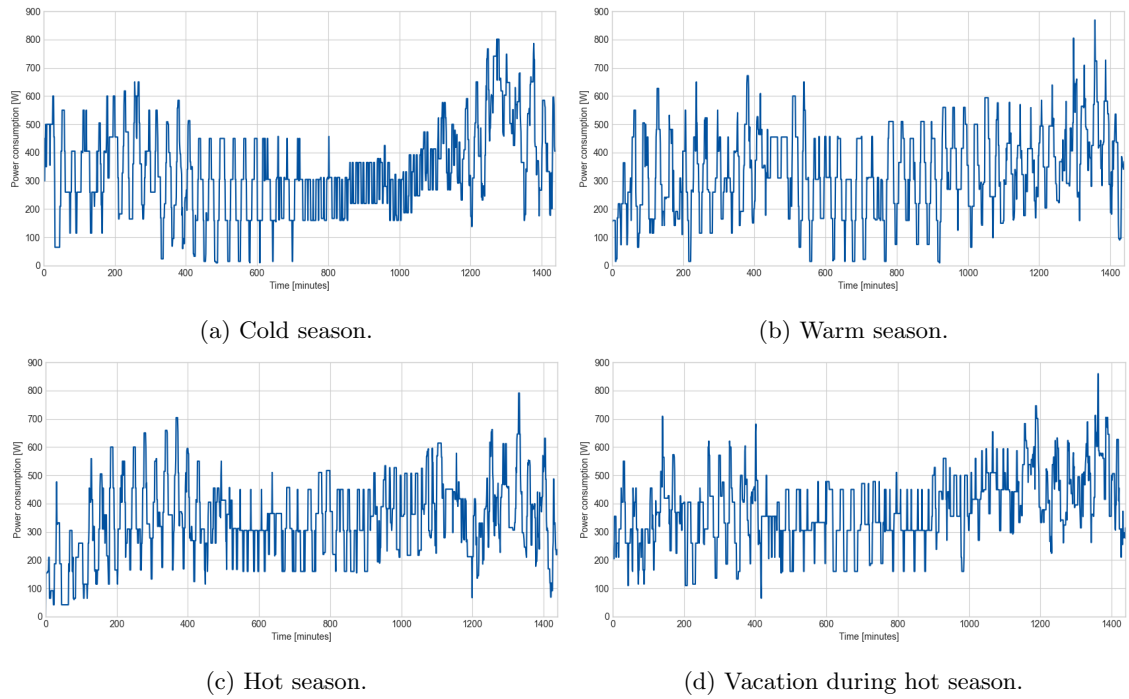

Figure 41: Daily minute based load profiles for the Director's housing area during different seasons.

### 6.2.6 Student dorm area

The building types in the Student dorm area is presented in Table 30. The appliances accounted for in this area is presented in Table 31.

Table 30: Building types in the Student dorm area.

Building type	Acronym
Student dorm	SD
Student showers	SS
Student toilets	ST

Table 31: Appliances that are included in the load profiles of the Student dorm area

Appliance	Current	Expected
LED Indoor	X	X
LED Outdoor	X	X
Fan	-	X

Parameters related to the appliances in the Student dorm area are presented in Table 32. The school schedule affects user habits during the weekdays because the pupils are at school. Therefore, weekend and weekday behavior is differentiated, with more electricity usage during the weekends. Because the pupils leave the property during vacations, the buildings in the Student dorm area is not accounted for during these periods.

Table 32: Appliances assumed in the Student dorm area during a week in the hot season.

Appliance	m [qty.]	Usage [min]	Window 1	Window 2	Occasional use [%]	Days
LED Indoor	3	120	06:00-07:00	19:00-21:00	100	Weekday
LED Outdoor	2	60	19:00-07:00	-	100	Weekday
Fan	2	540	21:00-06:00	-	100	Weekday
LED Indoor	3	120	19:00-22:00	-	100	Weekend
LED Outdoor	2	60	19:00-07:00	-	100	Weekend
Fan	2	540	12:00-14:00	22:00-07:00	100	Weekend

Figure 42 presents daily load profiles during a cold and a hot season. As can be seen from the figure, the school hours are reflected in no appliance usage. The power consumption is similar for the seasons. However, some reduction in the load during the night can be seen, as less fan usage is accounted for in the cold season.

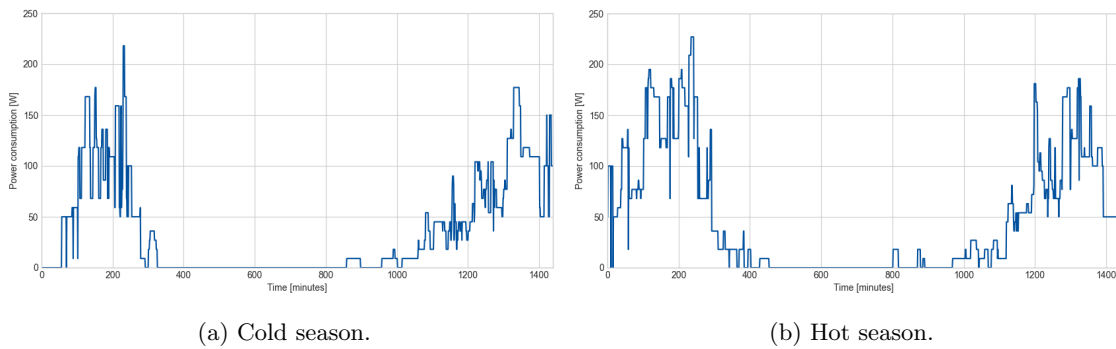

Figure 42: Daily minute based load profiles for the student dorm area with varying temperatures.

### 6.3 Future building projects

The expected expansions of the property will increase the electricity usage. As these are planned to be built within the next couple of years, the energy systems at the property should be able to supply these buildings. Hence, the expected future expansions that are presented in 5.10 are included in the load profiles. To account for the electricity demand of the future building projects, assumptions and predictions have to be made for both appliances and the user behavior related to these. The model input that is given based on this is presented in this chapter.

#### 6.3.1 The Computer Lab

The Computer Lab, with a building type that is denoted as CL, is expected to be used in teaching by classes with about 30 students. A laptop for each student is therefore included in the appliances assumed to be used in the CL. This can be seen in Table 33. As can be seen from the table, two different objects are made for the laptops. They are used as a tool to construct the different usage patterns that are assumed for the daytime. The laptops are expected to be used intensively until 17:00, accounting for possible after-school activities with the laptops as well. This after-school activity could, for instance, entail an educational program for adults in the village. After these activities, it is assumed that 5 laptops are occasionally used. Similar sporadic usage is included in vacations, but it is assumed that the CL is not in use during the weekends.

Table 33: Appliances assumed in a potential CL during the weekdays in the hot season.

Appliance	m [qty.]	Usage [min]	Window 1	Window 2	Frequency [%]
Laptop <sub>Day</sub>	30	360	07:00-17:00	-	100
Laptop <sub>Evening</sub>	5	60	17:00-19:00	-	20
LED Indoor	4	420	17:00-19:00	-	100
Fan	2	420	07:00-19:00	-	100

Figure 43 illustrates the daily electricity usage in the CL. The load profile reflects how the laptops are used until almost 17:00. It can be seen from the curve that there is a period during the middle of the day where none, or only a few, of the laptops are in use. As it is not known exactly how the school schedule will implement the Computer Lab into their classes, it is reasonable to assume that there will be periods where there are no classes, such as presented in the figure. However, it is not likely that the fan is used during other time periods than the laptops. As can be seen from the figure, the load profile captures the peak loads when all laptops are in use during the day.

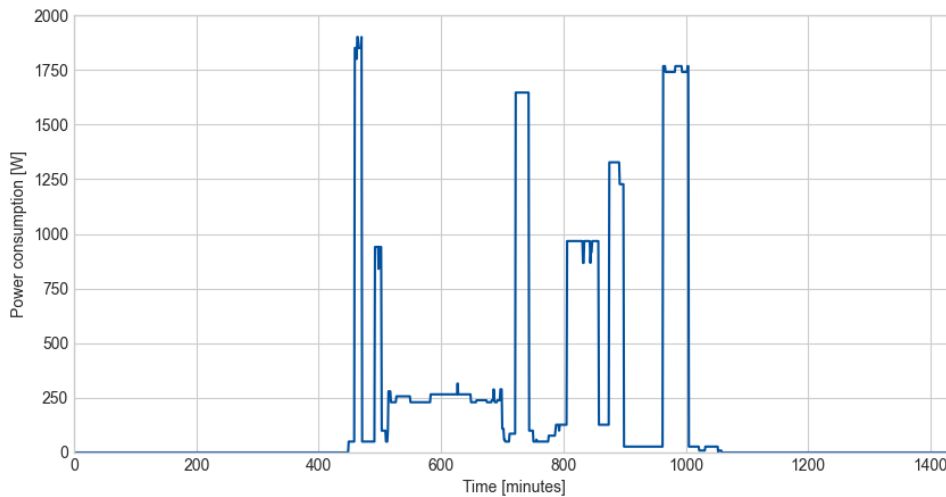

Figure 43: Daily minute based load profile for the CL during a normal school week in the hot season.

### 6.3.2 Expanded visitor area

To facilitate for the future prospects that are planned for the visitor area, the load profiles of this area will be expanded. This entails building more visitor huts, showers and toilets in the visitor area. It is assumed that such an expansion will entail three new buildings of type VH1. The number of visitor showers and toilets are doubled. Additionally, a hangout area (HA) is planned for. The building types related to the expanded visitor area is presented in Table 34. All building types except from the hangout area are identical to the building what was presented in Chapter 6.2.1.

The HA will allow for the visitors to cook their own food, and to hang out during the day. Similar appliances as in the kitchen is therefore assumed, but the usage pattern is more sporadic. The building types that are accounted for in the new visitor area is presented in Table 34, and the appliances associated with the hangout area during periods with high visitor activity is presented in Table 35.

Table 34: Building types defined for the expanded visitor area.

Building type	Acronym	n [qty.]
Visitor hut type 1	VH1	5
Visitor hut type 2	VH2	1
Visitor toilets	VT	2
Visitor showers	VS	2
Hangout Area	HA	1

Table 35: Appliances assumed for the hangout area for visitors during hot season with high visitor activity.

Appliance	m [qty.]	Usage [min]	Window 1	Window 2	Frequency [%]
phone	6	120	07:00-00:00	-	50
Laptop	6	120	07:00-00:00	-	50
Fan	2	420	12:00-15:00	19:00-00:00	50
Small speaker	1	60	12:00-20:00	-	50
Indoor LED	4	240	06:00-07:00	19:00-00:00	100
Outdoor LED	1	120	06:00-07:00	19:00-00:00	100
Fridge	1	1440	00:00-00:00	-	100

**Accounting for seasons with low visitor activity** To account for the periods with low visitor activity, the same adjustments as presented in Chapter 6.2.1 are made to the visitor huts. This entails that only one VH1 with three visitors is accounted for. Additionally, activity in the assumed new visitor showers and toilets is not included. The appliance usage in the HA is adjusted as well. This results in the building types that are presented in Table 36.

Table 36: Building types defined for the expanded visitor area during periods with low visitor activity.

building type	Acronym	n [qty.]
Visitor hut type 1	VH1	1
Visitor toilets	VT	1
Visitor showers	VS	1
Hangout Area	HA	1

The appliances in VH1 is the same as presented in Table 53, whereas the appliances assumed in the HA is presented in Table 37. As can be seen from the table, the number of phones and laptops are reduced.

Table 37: Appliances assumed in hangout-area for visitors during hot season with low visitor activity.

Appliance	m [qty.]	Usage [min]	Window 1	Window 2	Frequency [%]
Phone	3	120	07:00-00:00	-	50
Laptop	3	120	07:00-00:00	-	50
Fan	2	420	12:00-15:00	19:00-00:00	50
Small speaker	1	60	12:00-00:00	-	50
Indoor LED	4	240	06:00-07:00	19:00-00:00	100
Outdoor LED	1	120	06:00-07:00	19:00-00:00	100
Fridge	1	1440	00:00-00:00	-	100

Figure 44 illustrates the daily power consumption in the expanded visitor area during periods with high and low visitor activity. As can be seen from the figure, the load significantly decreases during periods with low visitor activity. The peak load is around 4 lower than for the periods with high activity. The user patterns when the visitor activity low entail less variations as well. When the visitor activity is high, consumption increases in the morning, during lunch, and in the evening. This reflects how the visitors hang out during lunch hours and in the evening. The fridges ensure that there is some constant power consumption throughout the day during both seasons. The figures present how the annual load profile of the expanded visitor area will vary with significantly different electricity needs during the different seasons.

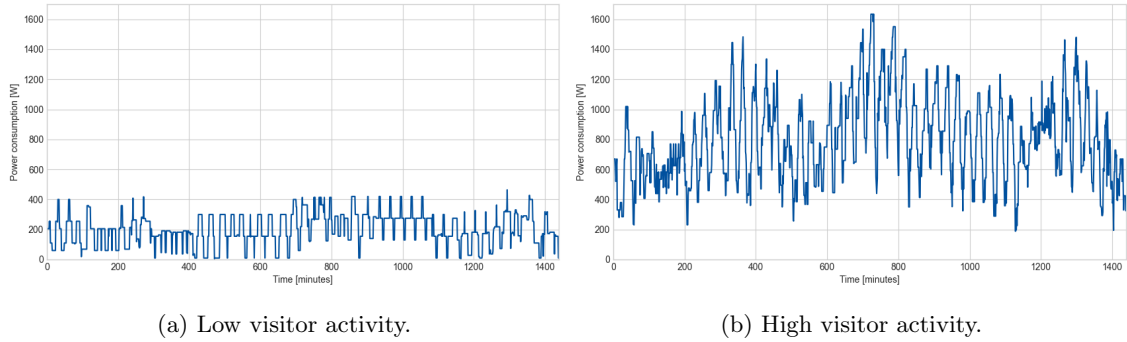

Figure 44: Daily minute based load profiles for the expanded visitor area with varying visitor activity during a warm season.

### 6.3.3 Multi-purpose building

The building type that is established for the multi-purpose building (MPB) is assumed to be using fans and lights during the school day to be used for sports. As it is supposed to be an area that could be used outside of the school schedule as well, the time windows extends until 19:00 in the weekdays. Some phone charging and a speaker is included after the school day ends, to account for people who will use the hall as a place to gather is assumed to be used throughout the week. The building is assumed to be used during the weekends as well, with some adjustments to the time windows. The same user behavior as during the weekends is assumed for the vacation. This is because it can be used as a common area to gather people independently of the school activity. An overview of the appliances assumed to be used in the multi-purpose building during the weekdays and the weekends in the hot season is presented in Table 38 and Table 39, respectively.

Table 38: Appliances assumed in the MPB throughout the weekdays.

Appliance	m [qty.]	Usage [min]	Window 1	Window 2	Frequency [%]
Indoor LED	10	600	07:00-19:00	-	100
Fan	5	480	07:00-19:00	-	100
Phone	5	120	15:00-19:00	-	50
Medium speaker	1	60	12:00-19:00	-	50

Table 39: Appliances assumed in the MPB in the weekends.

Appliance	m [qty.]	Usage [min]	Window 1	Window 2	Frequency [%]
Indoor LED	10	600	12:00-21:00	-	100
Outdoor LED	5	60	19:00-21:00	-	100
Fan	5	360	12:00-21:00	-	100
Phone	5	120	12:00-21:00	-	50
Medium speaker	1	60	12:00-21:00	-	50

Figure 45 presents the daily load profile of the MPB during vacation and weekdays. Figure 45a and Figure 45b respectively present a day during the vacation and a regular school week. As the same user behavior is assumed for the weekend as for the vacation, Figure 45a also represents the weekends.

During the weekdays, the afternoon activity that is accounted for is reflected in a load increase due to phone charging and the speaker. However, the building does not require much power supply, as the hourly peak load is less than 350 W. The peak consumption can be seen to be slightly lower for the vacation. However, it can be seen from the load profile how the appliance’s time window is increased during this period, as the consumption is more spread throughout the day.

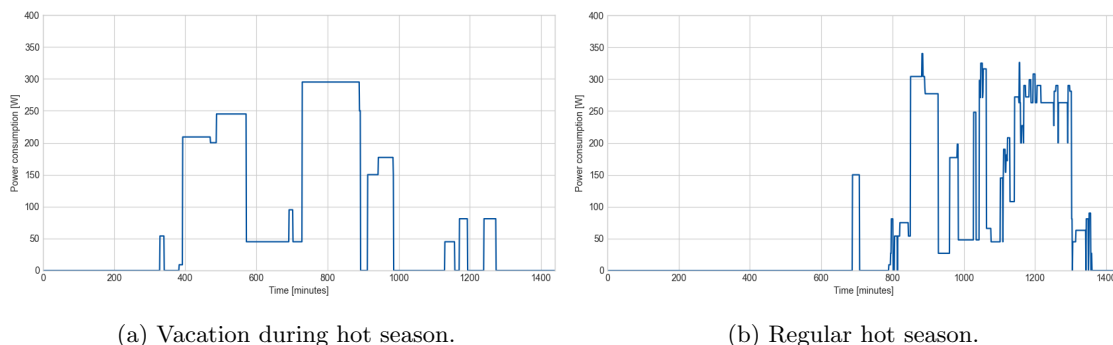

Figure 45: Daily minute based load profiles for the MPB during different periods of the year.

### 6.3.4 Workshop

The workshop (WS) is planned to be used for both teaching and creative work. The Appliances assumed to be used during the weekdays in the workshop is presented in Table 41. Tablets might be used as a part of this as well, and are included as appliances in the building. Appliances related to this part of the WS is assumed to be used after the school day to allow for both after-school activities, and for other people to utilize the facilities.

The maintenance work by the caretaker at the property involves the usage of several tools related to this. These appliances are presented in Table 40. It is assumed that the time window for the usage of these appliances is limited to be after the school day. During the weekends, the time window is expanded. All appliances related to maintenance use are only occasionally used, as it is not known how extensive or regular it will be if the electricity access enables the caretaker to work. This is reflected in the low frequency that is given as model input. Additionally, weekly usage is accounted for in case the tools in the workshop are made available for creative work as well or for other people to use. Some activity related to maintenance work is also assumed to be present during the vacations. The model input that is given for the different appliances is presented in Table 41.



Table 40: Appliances assumed for maintenance work in the WS.

Appliance	m [qty.]	Power [W]	t_min [min]	$\delta_{frames}$ [%]	$\delta_{t_{min}}$ [%]
Drill (cordless)	1	100	5	10	35
Circular saw	1	2400/720	5	10	35
Angle grinder	1	1050	5	10	35

Table 41: Appliances assumed in the WS during the weekdays in the hot season.

Appliance	m [qty.]	Usage [min]	Window 1	Window 2	Frequency [%]
LED Indoor	8	480	07:00-19:00	-	100
Fan	4	480	07:00-19:00	-	100
Tablet	10	120	07:00-19:00	-	50
Drill (cordless)	1	30	15:00-19:00	-	10
Circular saw	1	30	15:00-19:00	-	10
Angle grinder	1	30	15:00-19:00	-	10

### Duty cycles of the circular saw

The circular saw has a much higher starting power consumption than when it is running. Duty cycles are therefore established for the circular saw to ensure that the daily energy consumption is not overestimated. As can be seen from Table 42, the duration of the for starting power consumption is set to 5 minutes.

Table 42: The duty cycles of the circular saw.

Parameter	Value
Duration duty cycle 1 [min]	5
Power rating 1 [W]	2400
Duration duty cycle 2 [min]	25
Power rating 2 [W]	720

Figure 46 illustrates the daily load profile of two scenarios. Figure 46a presents a day where none of the high-consuming maintenance is used, whereas Figure 46b presents a day where such appliances are in use. As seen from the figure, the occasional usage of the maintenance-related appliances highly affects the load profiles. Whereas the other appliances consume less than 250 W in Figure 46a, the peak load is almost 2500 W higher in Figure 46b. This substantiates the choice of using duty cycles on the circular saw, as it highly affects the total electricity usage of the workshop. This could also entail that the power consumption in the workshop is overestimated, as the user behavior related to these maintenance tools might be less frequent than what is assumed. A weekly load profile is presented in Figure 47 for illustrative purposes. This figure demonstrates the usage frequency of the maintenance appliances.

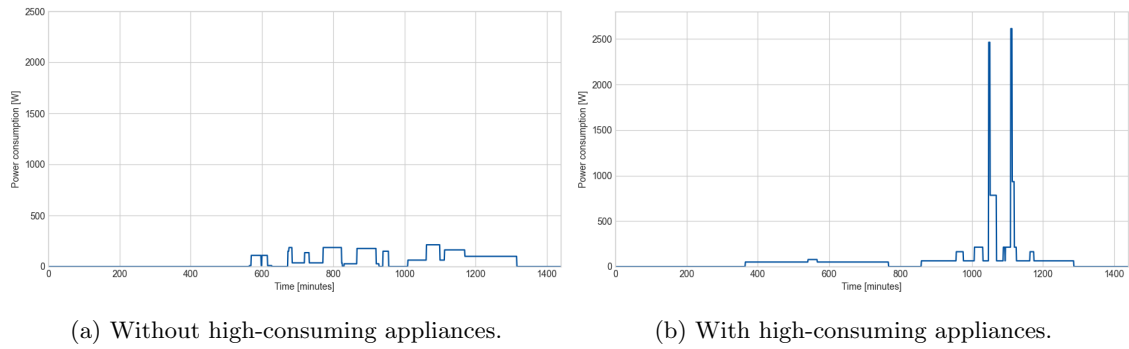

Figure 46: Daily minute based load profiles for the WS when different appliance usage is reflected.

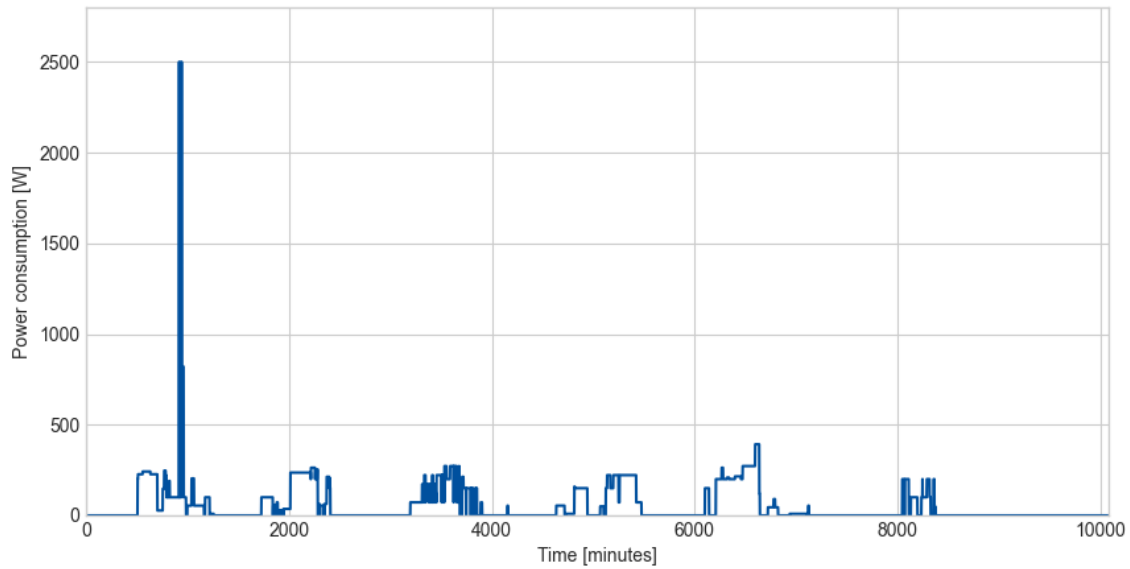

Figure 47: Weekly minute based load profile for the workshop during a regular school week in the hot season.

## 6.4 Daily load profile of the whole property

To compare the power consumption of the different buildings at the property, the graphical presentation presented in Figure 48 is constructed. The figure presents the power consumption at Eco Moyo on a day with high visitor-and school activity during the hot season. Hence, the load profile captures a period when power consumption is at its highest. The load profile of the areas or single buildings at the property is included, in addition to the aggregated load of the property as a whole.

It is desirable to capture how the different buildings' load profiles affect the whole property's power consumption. Additionally, it is interesting to see whether the different buildings' load peaks even out or amplify the peak load of the entire property. This reflects how simultaneously the power consumption is.

It can be seen from the figure that some of the buildings stand out as more decisive for the aggregated load profile. These are the expanded visitor area, the Computer Lab, and the workshop, i.e., all future expansions except the Multiple Purpose Building. The overall high consumption in the expanded visitor area can be seen to affect the overall curve of the aggregated load profile, apart from the hours with peak consumption during the day. The peak consumption of more than 5kW happens in the daytime at around 14:00. This peak seems to be affected by high consumption

---

in the Computer Lab and the Expanded visitor area. The peaks in the workshop a bit later in the day is directly reflected in similar peaks in the aggregated profile. Even though the school-related buildings, such as the Classroom area, have an overall smaller power consumption than, for instance, the expanded visitor area, they can be seen to affect the power consumption at the property when they peak between 11:00 and 12:00.

It can be seen from the graphs that most load profiles follow the same load curve as the aggregated profile, with increased consumption in the middle of the day. The buildings related to activities that are not only related to school also have a load increase in the evening. The most prominent peaks could be avoided by either adjusting the user patterns in, for instance, the Computer Lab by restricting the number of laptops that are charged simultaneously. Additionally, the electricity usage in the expanded visitor area could be better adjusted to the school schedule by reducing daytime consumption. However, the highest power consumption should happen during the hours when the power production from the PV panels is high. This is the case for the presented load profiles.

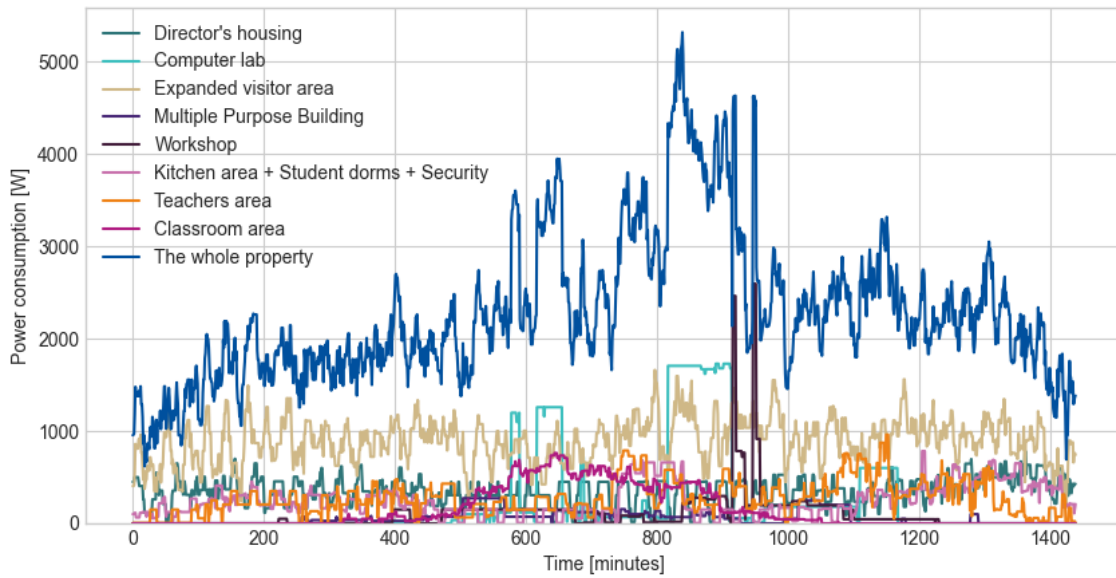

Figure 48: Daily minute based load profile of the whole property during the hot season.

---

## 7 System simulation in PVsyst

After establishing the load profiles, PVsyst is used to find possible system solutions for the property. These systems will be further evaluated in order to define the final optimized alternative, based on characteristics such as cost-effectiveness, acceptable performance, and feasibility. Off-grid solutions supplied by PV panels and batteries will be the main focus as it is desirable to keep Eco Moyo self-sufficient with renewable energy. Solutions where the property is divided into clusters will be compared to results for a microgrid that supplies the whole property without clusters.

Even though renewable, off-grid solutions will be the main focus, it is decided to evaluate alternatives that can enhance the reliability of the electricity supply. Backup solutions with diesel generators and grid connection will therefore be evaluated for the resulting off-grid systems. However, these alternatives will only be evaluated for illustrative and comparative purposes and will not be a part of the final proposed system solution.

Figure 49 presents an overview of the method used to obtain and evaluate possible system solutions. The workflow to obtain the most beneficial off-grid PV systems is marked in the figure with dotted lines, while the process of obtaining results for backup systems are illustrated outside these lines.

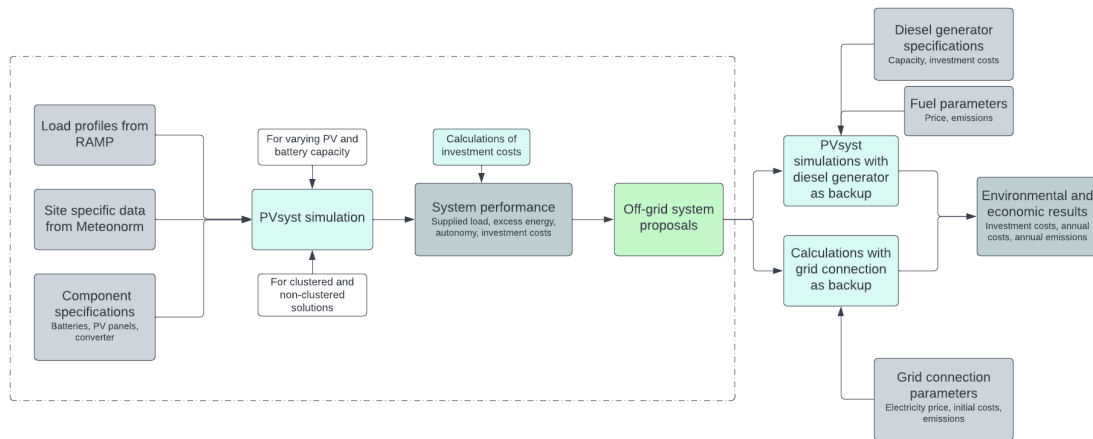

Figure 49: Methodology to obtain the system designs from PVsyst.

The following chapters will introduce a proposed system topology, the cluster-based approach, the simulation variables, and the model inputs. Thereafter, the off-grid system simulations in PVsyst is performed in Chapter 7.5. The results from the off-grid simulations will be used as basis for the backup evaluations with grid connection and diesel generators in respectively Chapter 7.6 and 7.7.

### 7.1 System topology

In this chapter, the system topology that will be used as basis for all system proposals will be presented. Both AC- and DC-coupled microgrids are considered alternatives. It should be noted that PVsyst do not differ between AC and DC load, and do therefore not take specified system topologies according to this as model input (PVsyst 2022g). The system topology presented in this chapter is therefore included to provide a more comprehensive system proposal than what PVsyst provides for off-grid systems. In the decision-making between proposing an AC- or DC microgrid, the different advantages and disadvantages presented in the theory is used as a basis.

The main advantages with DC microgrids used for the system topology decision-making is summarized as follows:

- Both PV panels and batteries are DC based and can therefore be directly connected to a DC bus, avoiding conversion losses. However, DC/DC conversion might be needed.

- If the loads are DC based, they can be supplied directly from the DC bus.
- DC microgrid do not need the voltage-and frequency regulations that AC microgrid requires.
- There are no reactive losses in DC microgrids, which can entail increased system efficiency.
- The power losses for 230 V DC compared to 230 V AC have been found to be generally lower for the DC system. However, for 48 V cables, it is found that the transfer capacity is significantly reduced for longer distances (Sannino et al. 2003)

The main arguments for using AC microgrids as the system topology is summarized as follows:

- The appliances at the property are currently AC based. Hence, an inverter is needed to supply the load, and conversion losses must therefore be accounted for if the microgrid is supplied by a DC distribution system.
- For a DC distribution system, a DC/DC boost converter would be needed to obtain the DC voltage that has better performance than the AC cables (Sannino et al. 2003). A DC/AC conversion would also be needed in the receiving buildings to supply the AC load. These converter losses can be avoided for an AC microgrid with an AC distribution system.
- AC microgrids are compatible with grid connections and diesel generators.
- Chloride Exide is familiar with AC microgrids, and have stated that DC microgrids are not mature enough to be considered by them yet.

Considering the conversion steps needed in a DC microgrid with AC load and potential connections to the utility grid or AC generating units, undesirable conversion losses would be prevented with an AC distribution system. Taking into account that AC microgrids are preferred by Chloride Exide as well, it is decided that an AC-coupled microgrid is a preferred solution for Eco Moyo. Figure 50 shows the resulting system topology used as the basis for all off-grid simulations in PVsyst, and, therefore, all system proposals. The system topology will be further expanded for solutions with grid connection and diesel generators as backup solutions. It should be noted that further details about the distribution systems, such as connection points, specifications related to the cables, and calculations of power losses and costs, are not a part of the research scope.

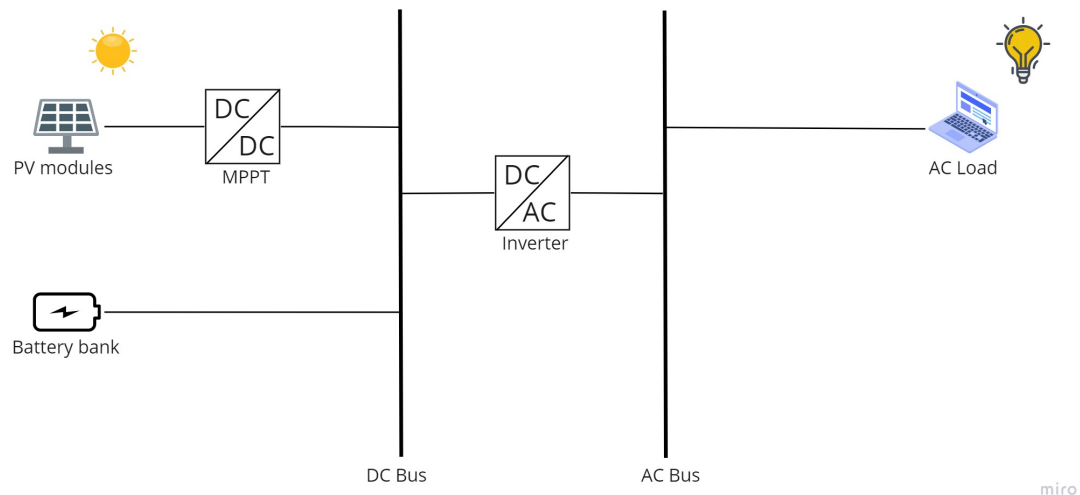

Figure 50: System topology used as basis for off-grid system simulations in PVsyst.

The figure shows that the established system topology includes a DC and an AC bus. The PV panels are connected to a DC bus through a DC/DC converter with an MPPT controller. The

---

choice of using this component will be elaborated in Chapter 7.4.2. A DC/AC conversion step is needed for the electricity from the PV panels and batteries to supply the AC load. Hence, an inverter is included. This conversion step is not accounted for in the PVsyst simulations (PVsyst 2022g). Hence, the simulation results do not entail conversion losses from the inverter. The costs of this component is, however, included in the economic results.

It should also be noted that the DC bus is included because the inverter and the MPPT controller are separate components. However, the DC bus could be removed if a hybrid solar inverter is used. An AC/DC conversion must also be included if DC appliances are to be supplied in the future. However, if the required competence is more available in such a future scenario, solutions with hybrid, i.e. both AC and DC, distribution systems, can be considered. To ensure that the proposed solutions are feasible with the currently available competence this master thesis will not investigate such solutions further.

## 7.2 Cluster based approach

As it is desirable to keep each cluster at the property self-sufficient, both clustered and non-clustered system proposals will be evaluated. A clustered system proposal entails that independent systems supply each cluster, whereas a non-clustered system supplies the whole property as one. There are several advantages and disadvantages related to both alternatives. These will be presented in this chapter.

Main advantages with a clustered solution:

- *Gradual expansions*: expansions of the property depends on having available funding. Investments of varying magnitudes are made to Eco Moyo on an irregular basis. A clustered solution allows for expansions of the electricity supply to happen gradually when funding is received. For a non-clustered solution on the other hand, the total investment cost is needed at once, and this can not be guaranteed with the current financial structure at Eco Moyo.
- *Current systems at the property*: a clustered solutions allows for the existing PV systems to function as temporary electricity supply until funding for further expansions are received. The clusters without any electricity supply can therefore be prioritized in the gradual expansions, as the existing PV systems can supply their respective clusters until they malfunction. This is relevant for the PV system at the kitchen, as well as the different SHS currently distributed throughout the property. As it is defined that such old systems will not be interconnected to the microgrid, this would not be the case for a non-clustered solution. Hence, this scenario would entail replacing components even though they currently work.
- *Reliability in case of failure*: separate systems entails separate faults. This gives that if the system in one cluster fails to supply its electricity demand due to system failure, systems in other clusters can provide electricity to some of the unmet load. This is relevant for movable appliances such as mobile and laptop charging, however not for permanent appliances such as roof fans and fridges.
- *Cable lengths*: a non-clustered solution can possibly entail extra cabling and longer cable lengths than for a clustered solution. This would result in a lower system performance, due to increased power losses in the cables. It could also entail increased investment costs due to both the increased cable lengths, and that larger capacities might be needed.
- *Local expertise*: it is known that Chloride Exide is able to install smaller, separate PV systems, and that a clustered solution is the preferred approach for them in future development of the property. Hence, it is found that the current local technological expertise might not allow for a fully satisfactory non-clustered solution.
- *Available technology*: technologies for modular microgrids exists, and could be applied to the school. Powerblox presents such an alternative, which can easily allow for further expansions without requiring the high experience, or knowledge level that is associated with grid expansions (Powerblox 2022). Currently, such solutions are significantly more expensive, and are

---

not considered a realistic alternative. However, such technology could be good alternatives for projects like Eco Moyo if the prices decrease once it is more mature. In that case, clusters could be interconnected easily if it is found to be desirable later.

- *Required area*: a clustered solution would entail less PV panels and battery packs in the same area. This can make it easier to find suitable locations for the components in the system.
- *Simultaneous electricity demand at the property*: most of the buildings have their peak electricity demand in the daytime, and generally similar curves in their load profiles. As no user flexibility is accounted for, no adjustments are made to even out the peak loads. Hence, the established load profiles do not necessarily require larger system investments for a clustered solution. The aggregated peak load at the property is so high that a large, and hence expensive, inverter would be needed if the solutions were not cluster-based.

Main advantages with a non-clustered solution:

- *Uncertainty related to future buildings*: the decision to include future building prospects in the system proposals might entail additional challenges to a cluster-based approach. Because the locations of these buildings have to be assumed, some of the defined clusters might be different than what will be realized. This gives that the electricity demand for the clusters can be wrongly estimated and that the system's location might have to be re-evaluated as well.
- *Varying electricity demand at the property*: if the peak electricity demand in the buildings varied throughout at the day, a non-clustered solution could be beneficial. If the electricity demand in the different buildings were compatible in the sense of having most of their consumption on different parts of the day, the peak of the load profile would be more evened out. This could entail smaller required system sizes than if adjusted for simultaneous peaks. In a clustered solution, the advantages of compatible loads and evened out peaks would not have been captured, as each system would be sized to their respective peak load.
- *Social aspects*: in a clustered solution, dissatisfaction among users regarding which clusters are expanded and given electricity access first can occur. It is therefore important to account for such social aspects when prioritizing electricity access at the property. Such dilemmas are not relevant for a non-clustered solution as it entails that all users gain electricity access at the same time.

To find the best system proposal, results from both clustered and non-clustered solution will be compared. In the clustered solution, the electricity demand of different areas of the property is supplied separately, where in the non-clustered solution the whole property is accounted for in one large, interconnected system.

### 7.2.1 Clusters and simulation cases

For the clustered solution, it is decided to initially divide the property into six clusters, referred to as Cluster 1 to Cluster 6. They are based on the existing clusters at the property, and on distances between buildings. Future buildings are accounted for. The clusters are presented in Figure 51.

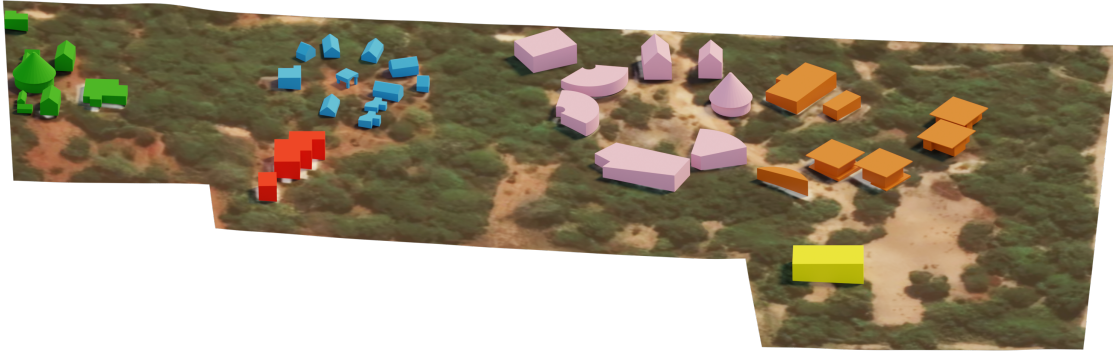

Figure 51: Cluster 1 (green), Cluster 2 (red), Cluster 3 (blue), Cluster 4 (pink), Cluster 5 (orange), and Cluster 6 (yellow).

Source: J. Lervik 2022.

Conclusively, the following seven divisions of the property will be evaluated through off-grid simulations in PVsyst:

1. Cluster 1: Security building, Student dorm area, and Kitchen.
2. Cluster 2: Director's housing area.
3. Cluster 3: Expanded visitor area.
4. Cluster 4: Staff Room, Director's Office, Leap Learning Lab, Workshop, and the closest classrooms. Entails existing system.
5. Cluster 5: Computer Lab, Staff Court, and the closest classrooms.
6. Cluster 6: Multiple Purpose Building.
7. Non-clustered: all buildings.

Conclusively, there are two possible solutions for the division the property in relation to the final proposed off-grid systems, which can be summarized as follows:

- Clustered solution: Cluster 1, 2, 3, 4, 5, and 6 simulated separately.
- Non-clustered solution: the whole property simulated together.

### 7.2.2 Load profiles for the solutions

To establish the load profiles for each cluster, the electricity demand for the relevant buildings are included in the same load profile simulation in RAMP. This ensures that the minute-based load in each building is accounted for, which can correspond to aggregating them into a load for the complete cluster as presented in Equation (8).

$$P_{ci} = \sum_{m \in M} P_{mi} \quad i \in O, c \in C \quad (8)$$

where

- $P_{ci}$  is the load at minute  $i$  in cluster  $c$
- $P_{mi}$  is the load at minute  $i$  in building  $m$



- $O$  is a set of the minutes throughout the year
- $M$  is a set of buildings in cluster  $c$
- $C$  is a set of all clusters

Conclusively, seven load profiles are generated in RAMP; for Clusters 1 to 6, as well as for the non-clustered solution. These load profiles are presented in Chapter 7.5.

### 7.3 Simulation variables

An overview and description of the simulation variables used for evaluation of the off-grid PVsyst simulations is shown in Table 43 (PVsyst 2022f).

Table 43: Simulation variables for off-grid PVsyst simulations.

Variable		Description
Available energy	[kWh/yr.]	The PV production from the given PV system.
Energy demand	[kWh/yr.]	The user's energy need. Defined as input data.
Energy supplied	[kWh/yr.]	Energy supplied to the user.
Energy missing	[kWh/yr.]	Electricity demand - electricity supplied.
Unmet demand	[%]	Ratio of energy missing to energy demand.
Excess energy	[kWh/yr.]	Unused energy due to full battery.
Autonomy	[days]	Time the energy demand can be met with the battery alone.
Investment cost	[NOK]	Total investment cost for batteries, PV panels and controllers.

The main parameters used for the decision-making is the unmet demand, excess energy, and autonomy. These variables are further explained in this chapter. The investment cost is also an important part of the decision-making, as it is desirable to propose a cost-efficient system.

#### Unmet demand

The performance of a system is highly reflected in its ability to supply the electricity demands. Therefore, the unmet demand is found to be one of the most important simulation variables when evaluating system solutions, as it expresses how much of the energy demand that is covered by the system. The unmet demand is defined as the ratio of the missing energy to the energy demand, as given in Equation (9).

$$\text{Unmet demand} = \frac{\text{Missing energy}}{\text{Energy demand}} \quad (9)$$

This value should be low for a well-performing system to ensure that the load is met. For similar parameters related to unmet demand, a value of 1.8 % is accepted in (Narayan, Vega-Garita et al. 2018) whereas an upper limit of 2 % is used in (Hosseinalizadeh et al. 2016). It is therefore concluded that an upper limit of 2 % on the unmet demand is to be applied when evaluating the system proposals for Eco Moyo. The unmet demand will be one of the main focuses when evaluating the simulation results in the following chapters.

#### Autonomy

The autonomy of a system is defined as the time the energy demand can be met with the battery alone. It is important for the system to be able to supply the energy demand in periods with less irradiation or if the system malfunctions. As stated in Chapter 3.3.2, typical values for autonomy is between 2 days and 12 days (Louie 2018, p. 401). A higher value gives a higher reliability for the system, but it will also increase the investment costs due to an increased battery bank capacity.

2 days is considered suitable for Eco Moyo because it can be expected that professional assistance to fix the system can be provided within this time frame. Additionally, if this is not the case, none

of the school activity is critically dependent on electricity supply. Hence, the school is expected to manage some time without electricity. However, as it is desirable to provide reliable electricity supply, it should be evaluated whether it could be beneficial to provide more days of autonomy. This choice depends on the costs.

To demonstrate the increased investment cost related to an improved autonomy, a simple sensitivity analysis is performed. It is performed on four different clusters with significantly different patterns for electricity demand, i.e. load profiles. These load profiles will be presented in Chapter 7.5. The clusters and their energy demands used in the sensitivity analysis for autonomy can be summarized as follows:

- Cluster 2, representing relatively even load throughout the year.
- Cluster 3, representing big variations throughout the year.
- Cluster 5, representing significant annual variations and high peaks loads.
- Cluster 6, representing a very small load.

2 and 4 days of autonomy are used as a respectively lower and upper bound for the analysis. Figure 52 gives the resulting correlation between investment costs and autonomy for the four clusters.

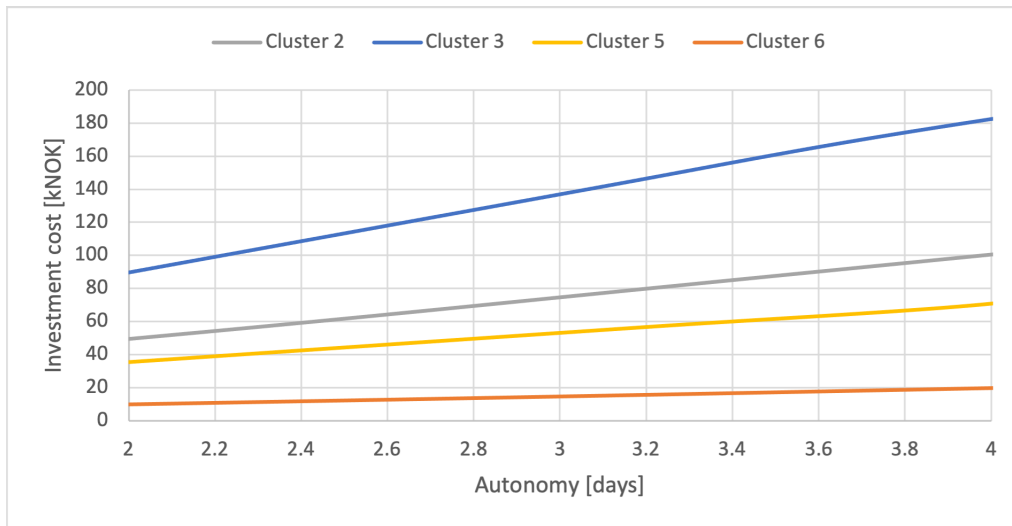

Figure 52: Sensitivity analysis of days of autonomy and related investment cost in kNOK.

The slopes of the graphs in Figure 52 gives that the additional cost for each extra day of autonomy for the four clusters are as follows:

- Cluster 2 : 25,075 NOK/day
- Cluster 3 : 45,675 NOK/day
- Cluster 5 : 19,844 NOK/day
- Cluster 6 : 4,886 NOK/day

Based on these values, it is found that the investment cost of an additional day of autonomy is high. Cluster 6 is the only alternative that has a low enough cost for an extra day of autonomy to be considerable. However, as the electricity usage in this cluster is small, and not considered critical to supply, it is concluded that it is not reasonable to introduce this investment. Hence, it is found that the investment cost of a higher autonomy is not worth the improved performance. Therefore, a minimum value of 2 days of autonomy is set for the system evaluations at Eco Moyo.

---

## Excess energy

The excess energy for the different solutions is not highly emphasized in the decision-making. This is because it is considered more important to make sure that the electricity demand is covered than to have a small amount of excess energy. However, excess energy can be a good indicator of whether a system is overdimensioned or not. If the excess energy value is high, it can indicate that the PV system might be larger than needed, which would entail inefficient investments.

However, in this thesis, the PV systems are designed to be able to supply the periods with the highest electricity demand. The electricity demand of many of the buildings varies much during different periods. This entails that the PV production will be too big for periods where the energy demand is lower than what the system is designed for. Hence, for the PVsyst simulations, a periodically high excess energy production is required and expected for the system to cover the energy demand throughout the year. This will be further evaluated for each cluster simulation in Chapter. 7.5.

## 7.4 Model input

The required model input data used in PVsyst can be summarized as follows:

- Site and weather data.
- Load profiles.
- Information about the system components.

This chapter will present the background of the decision-making regarding the site and weather data, as well as component selection. The resulting input data is also presented. Even though the investment costs are calculated outside the simulations, the component prices are also included in this chapter. It should be noted that the investment costs do not consider any other components than the what was presented in Figure 50.

### 7.4.1 Site and weather data

The first step of the simulation in PVsyst is to define the project site. This is because PVsyst uses the longitude and latitude to calculate the position of the sun every hour throughout the year. PVsyst also requires hourly data about horizontal global irradiance and ambient temperature to perform a detailed simulation. This data can be obtained either through a Meteonorm database implemented in PVsyst, by importing measured data, or importing data from available data sources. In the preliminary project it was found that both Photovoltaic Geographical Information System (PVGIS), NASA SSE and Meteonorm were three suitable alternatives for weather data collection, and all these options are available in PVsyst.

The following section is directly extracted from the preliminary project (K. T. Lervik and Waitz 2021, p.33).

Data sets from NASA SSE are sourced from satellite records, whereas Meteonorm and PVGIS data are mainly collected through interpolating results from records of nearby meteorological stations. The long-term average meteorological data sources of both PVGIS and NASA SSE are within 5 % of the Meteonorm solar radiation (Mahachi and Rix 2017).

According to (Silva et al. 2018), NASA SSE and Meteonorm databases stand out from other meteorological data platforms. (...) NASA SSE is a reliable global solar radiation data provider for areas lacking surface measurements. However, Meteonorm is considered a more robust meteorological data source (Mahachi and Rix 2017). Even

---

though (Silva et al. 2018) conclude that NASA SSE presents results closer to the measured solarimetric data, Meteonorm is considered a more accurate alternative. This is because the measured meteorological data provided by Meteonorm is collected between 1991 and 2010, while the NASA SSE database only provides collected data until 2005 (Silva et al. 2018).

To capture the effects of climate change, which are briefly discussed in Chapter 3.1.2, it is desirable to use the most recent data of the two alternatives. Meteonorm is therefore chosen as the source of site and weather data. This data is provided by Stanislas Merlet at the geographical coordinates 3.5°S and 39.8°E (Merlet 2021).

#### 7.4.2 System components

The choice of PV panels, batteries and controllers used as input to PVsyst is further described in this chapter, as well as the nominal voltage level.

##### PV panels

The PV panels installed at the new PV system during fieldwork had a size of 450  $W_p$ . These panels are known to be available at the site, the price is known, and the data sheet is given. Based on conversations with Chloride Exide it can also be assumed that PV panels with this capacity will be used in the future installations at the property. Hence, using these PV panels in the PVsyst simulations can contribute to a system proposal with less uncertainty. However, a capacity of 450  $W_p$  is relatively big. In comparison, Stanislas Merlet has suggested a capacity in the range 250  $W_p$  to 300  $W_p$  for these types of systems (Merlet 2021). Using PV panels in the simulation that are as big as 450  $W_p$  include big step lengths in relation to the system capacity when adding or removing one PV panel in the system simulations. This can result in solutions where the optimum lies between the 450 W difference. Thus, to analyze the potential impact of having a 450  $W_p$  PV panel capacity compared to a smaller size, a simple sensitivity analysis is performed.

To compare with a 450  $W_p$ , the sensitivity analysis is performed with a 280  $W_p$  PV panel. This is because a PV panel with this capacity from the same brand as the one installed at the property exists in the PVsyst database, and hence it can be assumed that Chloride Exide is able to obtain it. Further, the data sheet for this is found online, and the capacity is also within the boundaries recommended by Stanislas Merlet (Merlet 2021).

The sensitivity analysis is performed by evaluating the difference between the 450  $W_p$  and 280  $W_p$  PV panels in relation to investment costs and performance. The performance parameter used is unmet demand. As presented in Chapter 7.3, a value below 2 % is requested. Hence, the sensitivity analysis entails finding the system proposals that meets this requirement for both PV panel sizes, and comparing the results of these. It should be noted that for the calculation of investment cost, a common price per  $W_p$  is used for both PV panel capacities. This is based on a price comparison of mono crystalline PV panels on the Chloride Exide website, which all have the same price per  $W_p$ , i.e. 4.04 NOK per  $W_p$ . Therefore, this is assumed to be an acceptable assumption.

The same clusters as used for days of autonomy is used due to the distinctions in the load profiles for these clusters. Figures 53 shows the results of the sensitivity analysis, where Cluster 2, 3, 5, and 6 are shown in respectively green, blue, yellow, and grey for both the unmet demand and the resulting investment cost for the PV panels.

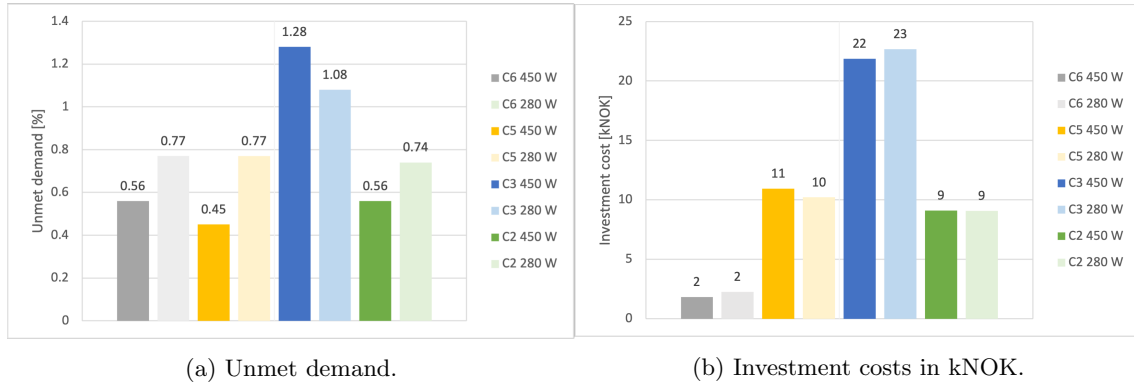

Figure 53: Sensitivity analysis PV panel capacity.

Figure 53a shows that the optimized system solutions with 450 W<sub>p</sub> have a slightly lower unmet demand for all clusters except for Cluster 3. However, the differences for this cluster are small, with an improved unmet demand of 0.2 % for the 450 W<sub>p</sub>. The improved performance regarding unmet demand for the four remaining clusters is also in the same range. Furthermore, Figure 53b shows that the investment costs when using 450 W<sub>p</sub> and 280 W<sub>p</sub> PV panels are the same for both Cluster 2 and 6. However, the 450 W<sub>p</sub> is 1000 NOK more expensive for Cluster 5, and the 280 W<sub>p</sub> is 1000 NOK more expensive for Cluster 3. Despite these differences, it is observed that the 280 W<sub>p</sub> and the 450 W<sub>p</sub> PV panels offer close to equally good solutions regarding performance and cost. This is concluded to confirm that a panel size of 450 W<sub>p</sub> does not entail that the optimum is bypassed. Hence, using PV panels with a capacity of 450 W<sub>p</sub> in the simulations is acceptable and will be used in further simulations.

## Batteries

The new PV system installed during fieldwork included lead-acid batteries. However, based on the advantages of lithium-ion batteries presented in Chapter 3.3.2, it is decided to use this battery type in future installations at the property. Even though these batteries require higher investment costs, it is considered more important to prioritize a battery type with a long lifetime, as well as high efficiency and energy density. It is also important that lithium-ion batteries are considered more environmentally friendly than lead-acid batteries, as this is in line with the green profile that Eco Moyo wants to maintain. Additionally, given that the batteries' discharging rate is regulated so that the lifetime of lithium-ion batteries are prolonged, the LCOE is expected to be lower than for lead-acid because fewer replacements have to be made for this battery type.

A battery with similar capacities as the lead-acid battery installed at the site during fieldwork is used as model input in PVsyst. Chloride Exide is known to have components from the manufacturer Victron Energy, and therefore a 12.8 V and 202 Ah from them is chosen for the simulation of all future PV systems. The SoC is set to the default value determined by PVsyst, which is 10 %. This is lower than what would be recommended based on the theory in Chapter 3.3.2. However, due to lithium-ion batteries' ability to deeply discharge, it is decided to keep the default value.

The Kenyan price for the chosen battery is not found. The price that is used in the calculations of the investment costs of the lithium-ion battery is therefore based on the price difference between lead-acid and lithium-ion batteries in the Norwegian market. It is found that a 12.8 V 200 Ah lithium-ion battery is approximately 2.75 times more expensive than a 12 V 200 Ah lead-acid battery (Solry 2022b, Solry 2022a). The price for the lead-acid battery installed at the property during fieldwork was 2,577 NOK. Assuming the same ratio for the Kenyan market, 7,087 NOK is given as model input for the lithium-ion battery price in PVsyst.

For simulations of the existing PV system, i.e. Cluster 4, lead-acid batteries are used in order to get an as accurate simulation as possible. The default value for SoC<sub>min</sub> of the lead-acid battery is set to 20 % by PVsyst. However, deeply discharging the lead-acid batteries to this level will highly affect the battery lifetime. The SoC<sub>min</sub> is therefore set to 50 % instead. This is in line with the theory presented in Chapter 3.3.2. However, it should be noted that this might differ from what

---

is actually programmed for the charge controller at the property.

### Controller and inverter

The main concern in PVsyst simulations is the sizing of the battery pack and the PV array power as a function of the energy demand, site, and weather data. However, the exact control strategy is not considered essential in this simulation tool. Therefore, PVsyst has introduced an option to choose a so-called “universal generic controller”. During the specification of the PV array and battery pack, the universal generic controller will adapt its parameter so that it always stays compatible with the system’s normal behavior without control losses. This is the recommended option by PVsyst (PVsyst 2022i). Hence, for the simulations, a generic universal controller is chosen.

A choice between an MPPT, DC/DC, and a direct coupling controller strategy needs to be made. All of which include DC/DC conversion steps. Additional DC/AC conversions are not accounted for in off-grid simulations (PVsyst 2022a). An MPPT controller strategy is chosen to ensure that the maximum PV power output is obtained. Even though this is known from the fieldwork to be a more expensive alternative than a DC/DC converter, high system performance is prioritized. It is also known that Chloride Exide can provide, and is experienced with, such components.

To obtain the price for the MPPT controller and the inverter, a common price per watt is used. The price is based on what is provided by Chloride Exide for Victron Energy MPPT controllers and inverter. Based on this, a common price of 5.75 NOK per  $W_p$  is used for the MPPT controller and the inverter in all clusters. The capacity of the MPPT controller and the inverter is set equal to the peak load for each cluster. Hence, the total investment costs of the MPPT controller and the inverter is calculated as presented in Equation (10).

$$IC_{converters} = p_{common} \cdot L_{peak} = 5.75 \cdot L_{peak} \quad (10)$$

where

- $IC_{converters}$  represents the total investment costs of the MPPT controller and the inverter [NOK]
- $p_{common}$  represents the common marginal costs of the components [NOK/ $W_p$ ]
- $L_{peak}$  represents the peak load of the load that is supplied by the system [ $W_p$ ]

### Nominal voltage level

It is decided to use the same nominal voltage level as a basis for all clusters at the property. This is so that the PV systems for each cluster to be more easily connected in the future if desired. Therefore, a nominal voltage of 48 V is chosen for the battery bank. Due to high efficiencies and safety, the research performed in (Anand and Fernandes 2010) states that the optimal DC voltage is 48 V for residential applications. This is the same voltage level as for the installed system in Cluster 4, and also what is recommended for systems with energy demand over 4 kWh per day (Louie 2018). In order to reach this voltage level, four and four batteries have to be connected in series. As 12.8 V lithium-ion batteries will be the proposed battery type, the common nominal voltage will be 51 V for all clusters except Cluster 4.

Using a common nominal voltage level of the battery packs can, however, lead to bigger battery banks than necessary, as the battery quantity needs to be  $+/-$  four. This can give big steps in the performance, where the optimal solution can lie between these  $+/-$  four batteries. An unnecessarily big battery bank would also include inefficiently high investment costs. Therefore, a sensitivity analysis for the impact of the same nominal voltage level for all clusters is performed. PVsyst suggests a voltage level for the battery pack based on the given energy demand. The sensitivity analysis will be performed by comparing the performance and investment costs of system solutions with a 51 V battery bank and the voltage suggested by PVsyst. This will be done for the clusters that have a suggestion of a lower battery bank voltage than 51 V. The presented solutions are chosen based on what can provide the lowest value for the autonomy over the limit of 2 days.

Figure 54 shows the resulting days of autonomy and investment costs for the three different clusters with the two different voltage levels. Cluster 1, 5, and 6 is shown in respectively green, orange, and blue.

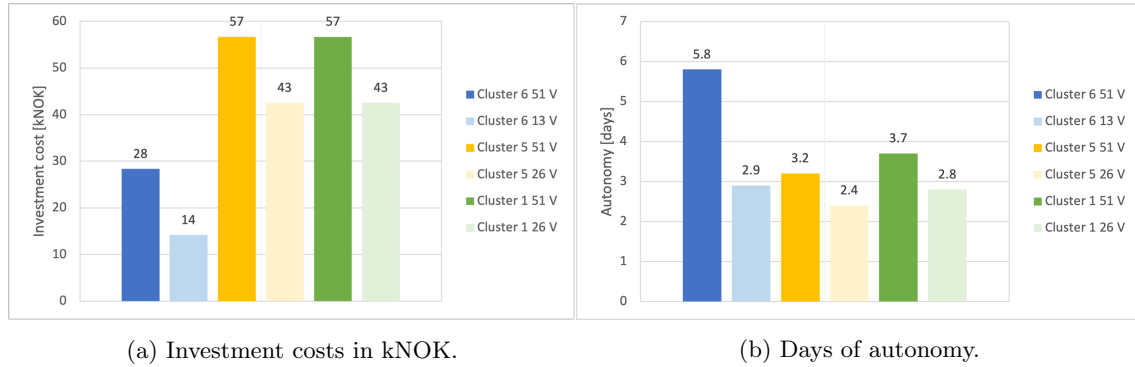

Figure 54: Sensitivity analysis battery pack voltage level.

Figure 54a shows that a voltage level of 51 V gives an increased investment cost of 14,000 NOK for all clusters compared to the default voltage level. This is due to that two additional batteries are needed for all the clusters with a battery pack of 51 V. Figure 54b shows that the resulting autonomy for Cluster 6 with a battery pack of 51 V is 5.8 days. This is considered to be unnecessarily high. The energy demands and activities in this cluster is also considered to not be particularly critical, and therefore an autonomy of 5.8 days is not needed. The 2.9 days of autonomy for a 13 V battery pack is already high enough. Therefore, the additional investment cost of 14,000 NOK is not found to be worth it, and the voltage level for the battery pack in Cluster 6 is set to 13 V.

For Cluster 1 and 5, the energy demand and activities are defined to be more critical than those for Cluster 6. Additionally, more buildings and appliances are included in these clusters, and therefore the energy demands here are higher than that for Cluster 6. Further, if future connections of clusters are to happen, it is likely that Cluster 1 and Cluster 5 is to be included in this. Therefore it is worth the increased investment costs of having battery packs of 51 V in Cluster 1 and Cluster 5. Hence, for all other clusters than Cluster 6 with lithium-ion batteries, the nominal voltage is set to 51 V in the PVsyst simulations.

## 7.5 Off-grid system simulations

In this chapter the off-grid system simulations in PVsyst is presented. Several system solutions, i.e. amount of batteries and PV panels, will be evaluated for each cluster as well as for the non-clustered solution. The optimized system solution will be decided for each cluster and the non-clustered solution based on performance and economic results from PVsyst.

### 7.5.1 Cluster 1 simulations

Cluster 1 includes the kitchen, student dorm area, and the security building. For this cluster, it was found during fieldwork that the only building with roof strong enough to hold larger installments is the kitchen. Hence, the PV panels are proposed to be place at this building. This gives that the PV panels are placed with an azimuth of  $-120^\circ$  and a plane tilt of  $7.5^\circ$ . The cluster and PV panel placements used in PVsyst are illustrated in Figure 55.



Figure 55: Cluster 1 in green with PV panels on kitchen.

Source: J. Lervik 2022.

### Energy demand

The annual energy demand for Cluster 1 is found to be 1,842 kWh, and the peak load is 1,302 W. The plot for the aggregated annual load profile is presented in Figure 56.

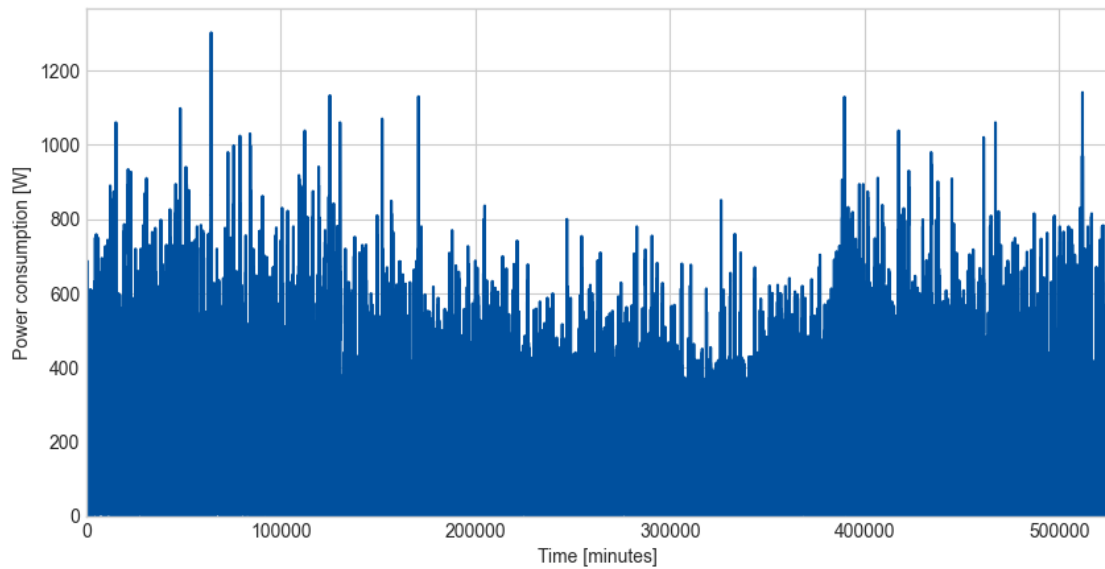

Figure 56: Annual minute based load profile for Cluster 1.

In this cluster the most significant electricity demands are in the kitchen. These are dependent on the amount of visitors at the property, and therefore there are some annual variations. These variations are apparent in Figure 56, e.g. as the significantly lower load in the months from May to August (around 200,000 minutes to 350,000 minutes in the graph) when there is less visitor activity. The figure also shows that there are some prominent peaks when there are more visitors.

### Simulations

The optimized amount of batteries and PV panels are to be decided. First, the amount of batteries will be chosen based on an acceptable value for days of autonomy. Then simulations with this amount of batteries will be used to decide the amount of PV panels, which will be chosen based on an acceptable value for unmet demand. This is the method used that will be used for all simulations for all clusters.

Figure 57 shows the simulation results in relation to autonomy and unmet demand for different



system solutions for Cluster 1.

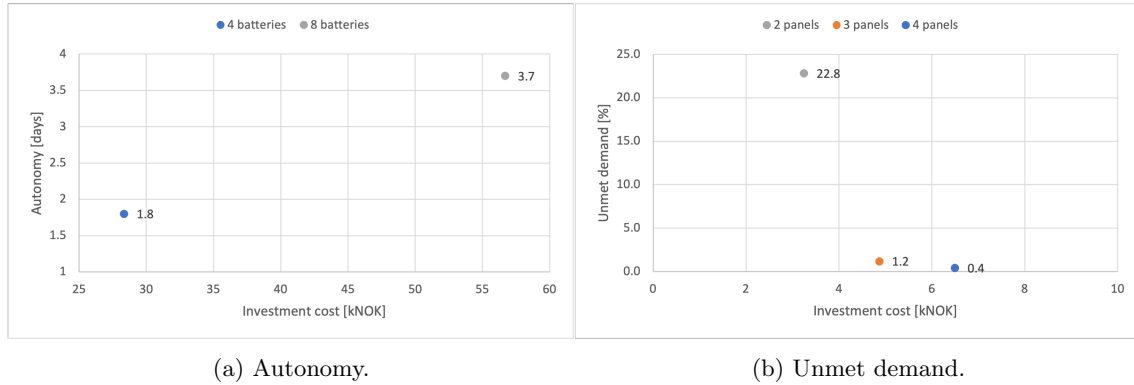

Figure 57: Simulation results for different system solutions in Cluster 1.

Figure 57a shows that system solutions with 4 and 8 batteries give respectively 1.8 days and 3.7 days of autonomy. Even though an autonomy of 1.8 days is in the lower range of what can be considered acceptable, a value of 3.7 days entails an additional cost of approximately 28,000 NOK. This is also a much higher autonomy than what is defined as the desired value. Thus, a solution with 4 batteries and autonomy of 1.8 days is chosen.

Furthermore, Figure 57b shows that system solutions with 2, 3 and 4 PV panels give unmet demands of respectively 22.8 %, 1.2 %, and 0.4 %. The first is considered way too high and is not considered a viable option. The solution with 3 PV panels and a resulting unmet demand of 1.2 % offers an acceptable value for unmet demand for a lower cost than 4 PV panels. Thus, a solution with 3 panels is chosen. This solution also gives an acceptable value for the excess energy of 354 kWh per year, i.e. 16 % of the annual available energy.

Conclusively the system solution offering the best compromise between investment cost and performance for Cluster 1 is with 4 batteries and 3 PV panels. This has an investment cost of 33,000. In addition, the peak load of 1,302 W gives a calculated cost of 7,500 NOK for the controller and inverter. Thus, the total investment cost for Cluster 1 is found to be approximately 40,500 NOK.

### 7.5.2 Cluster 2 simulations

Cluster 2 includes the Director's housing area. The PV panels are placed on the director's house, due to significant shadowing on the material storage roof. The azimuth and plane tilt is therefore set to respectively  $-113^\circ$  and  $6^\circ$  in PVsyst based on values found for the directors house during the fieldwork. The cluster and PV panel placement is illustrated in Figure 58.

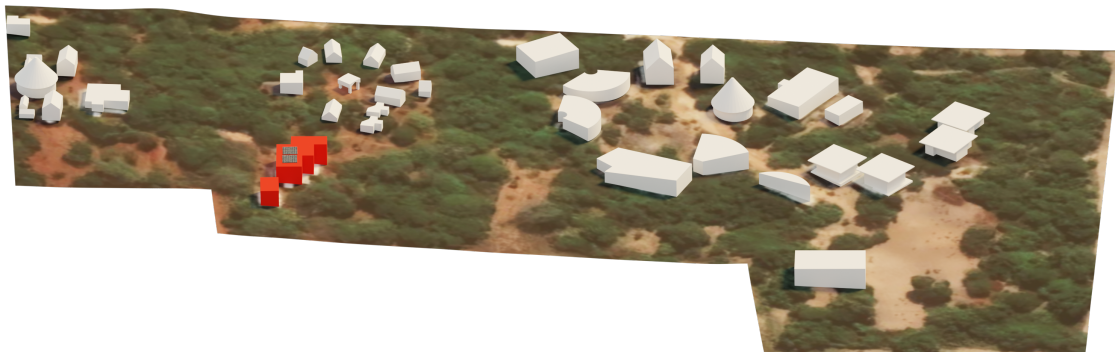

Figure 58: Cluster 2 in red with PV panel on directors house.

Source: J. Lervik 2022.

---

## Energy demand

The annual energy demand for Cluster 2 is found to be 3,019 kWh, and the peak load 937 W. The plot for the aggregated load profile for the cluster is presented in Figure 59.

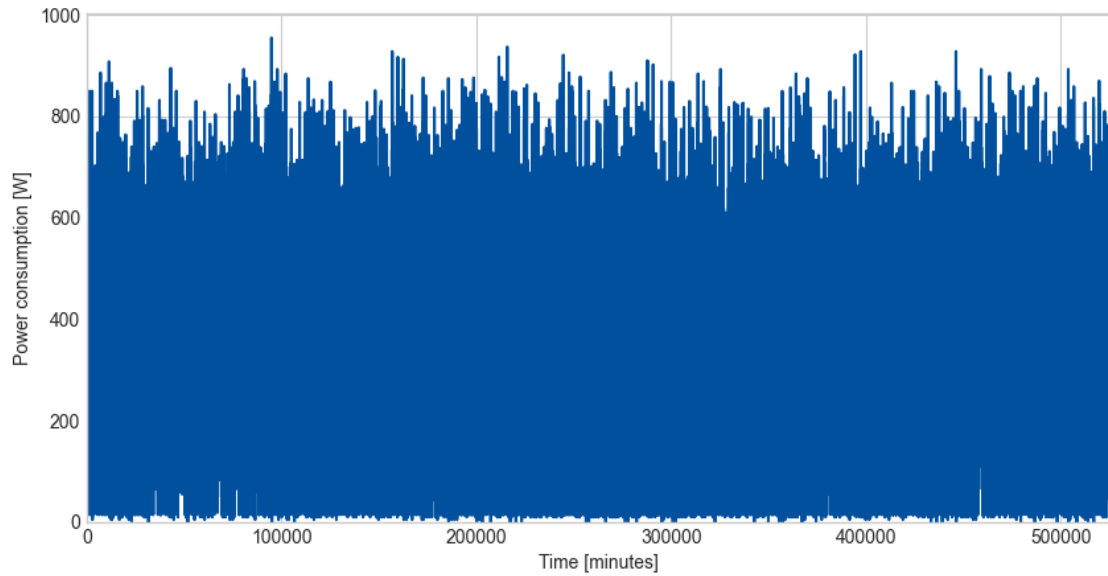
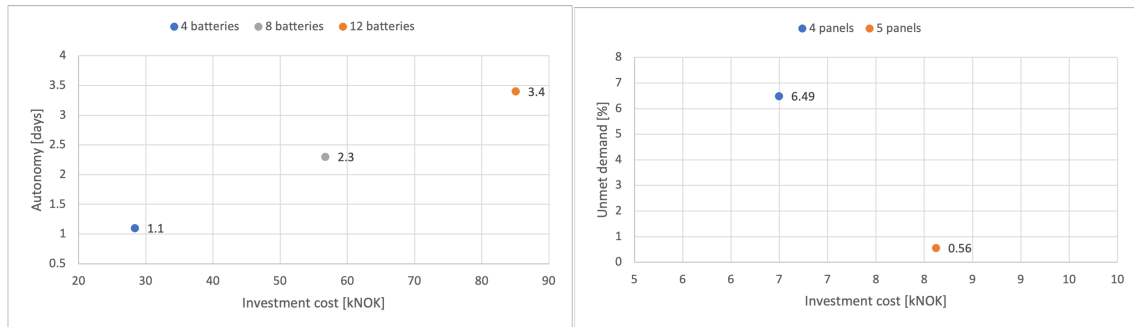

Figure 59: Annual minute based load profile for Cluster 2.

The figure shows that Cluster 2 has a relatively even load as the energy demands are not dependent on school vacations or visitor activity.

## Simulations

Figure 60 shows the simulation results for different system solutions for autonomy and unmet demand for Cluster 2.



(a) Autonomy.

(b) Unmet demand.

Figure 60: Simulation results for different system solutions in Cluster 2.

Figure 60a shows that system solutions with 4, 8 and 12 batteries give respectively 1.1, 2.3, and 3.4 days of autonomy. The solution with 8 batteries and 2.3 days of autonomy provides the only viable option with acceptable values for performance and investment costs.

Furthermore, Figure 60b shows that system solutions with 4 and 5 PV panels give an unmet demand of respectively 6.49 % and 0.56 %. Hence the only viable option is with 5 PV panels. The excess energy is equal to 642 kWh per year, i.e. 17 % of the annual available energy.

Conclusively the system solution offering the best compromise between investment cost and per-

---

formance for Cluster 2 is with 8 batteries and 5 PV panels. This has an investment cost of 65,000 NOK. In addition, the peak load of 937 W gives a calculated cost of 5,386 NOK for the controller and inverter. Thus, the total investment cost for Cluster 2 is found to be approximately 70,000 NOK.

### 7.5.3 Cluster 3 simulations

Cluster 3 entails the Expanded visitors area. As the current visitor area currently works fine with the installed SHS, it is assumed for this cluster that a new PV system will be installed at the same time as the new buildings in the visitors area. For this solution, it is assumed that the PV panels will be placed on a new building, such as the expected hangout area. This is because the current buildings can not hold larger installments. The defined cluster and PV panel placement is illustrated in Figure 61.



Figure 61: Cluster 3 in blue with PV panels.

Source: J. Lervik 2022.

### Energy demand

The load profiles for Cluster 3 also accounts for the expansions that are proposed for the visitor area. The annual energy demand for Cluster 3 is found to be 5,446 kWh, and the peak load is 2,460 W. The annual load profile for the cluster is presented Figure 62.

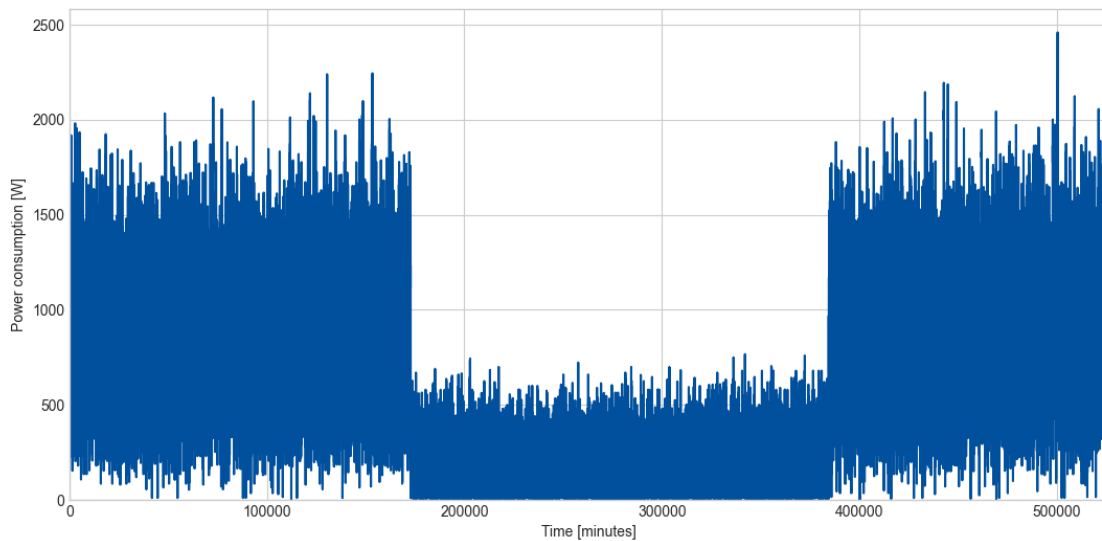

Figure 62: Annual minute based load profile for Cluster 3.

The figure shows the significant annual variations in the electricity demands in months with low and high visitor activity.

### Simulations

As the angles and azimuth of the new buildings are not yet known, they are determined based on the rules given in Chapter 3.2.4. Hence, the azimuth and plane tilt for the visitors area is set to respectively  $0^\circ$  and  $10^\circ$ . These value are to be used for all simulations of PV panels on buildings that are not yet built.

Figure 63 shows the simulation results for different system configurations for autonomy and unmet demand.

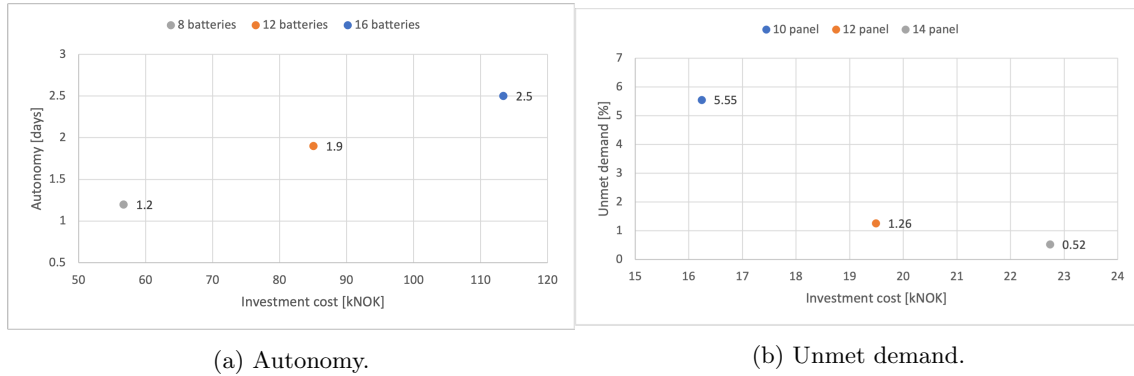

Figure 63: Simulation results for different system solutions in Cluster 3.

Figure 63a shows that system solutions with 8, 12, or 16 batteries give respectively 1.2, 1.9, and 2.5 days of autonomy. The load profile shown in Figure 62 gives that the low visitor activity occurs in the months May to September (around 200,000 minutes to 400,000 minutes in the graph), while Figure 8 gives that the average daily solar irradiation is lowest in these months as well. Thus, the most active visitor season is during periods with high PV production, whereas the low activity visitor season is during periods with lower PV production. Therefore 1.9 days of autonomy is considered acceptable, as the period with no or low generation most likely occurs during the off-season for visitors.

Furthermore, Figure 63b shows that system solutions with 10, 12 and 14 PV panels have unmet demands of respectively 5.55 %, 1.26 % and 0.52 %. The first is too high to be acceptable. A value of 1.26 % is, however, considered acceptable and therefore chosen as it provides a good compromise between investment costs and performance. This solution has a high value for excess energy equal to 3,532 kWh, i.e. 39 % of the annual available energy. However, the excess energy is high for all solutions in Cluster 3 due to the significant difference in the electricity demands in the months with high and low visitor activity. Thus a large system is needed to cover the periods with high visitor activity, which entails an oversized system for the periods with low activity. A high proportion of excess energy is thus considered unavoidable in Cluster 3.

Conclusively the system configuration offering the best compromise between investment cost and performance for Cluster 3 is with 12 batteries and 12 PV panels. This entails an investment cost of 105,000 NOK. In addition, the peak load of 2,460 W gives a calculated cost of 14,140 NOK for the controller and the inverter. Thus, the total investment cost for Cluster 3 is found to be about 119,000 NOK.

#### 7.5.4 Cluster 4 simulations

Cluster 4 will be supplied by the PV system that was installed during the fieldwork. As this PV system is already installed and implemented, the PVsyst simulation of this cluster will have a different objective than for the other clusters. The PVsyst simulation results will be used to

---

determine whether the defined cluster, i.e., included buildings, are suitable. If it is found to be too small or big, buildings can be added or removed. The performance of the installed system will also be evaluated to see if any modifications to the system should be made.

The buildings included in this cluster is based on a match between the electricity demand and the system size, in addition to reasonable distances. Therefore it is decided that the load profile for Cluster 3 will include classes 3 to 6, the Leap Learning Lab, the Staff Room, and the Director's Office. Furthermore, the Workshop is included in the load profiles for this cluster. This is based on the assumption that the Workshop will be built in the same area as the other buildings in Cluster 4. Figure 64 illustrates the buildings included in Cluster 4 and the current placement of the PV panels installed during fieldwork.



Figure 64: Cluster 4 in pink with PV panels on Class 5.

Source: J. Lervik 2022.

### Energy demand

The annual energy demand of Cluster 4 is found to be 2,267 kWh, the peak load 3,917 W. The plot for the aggregated annual load profile is presented in Figure 65.

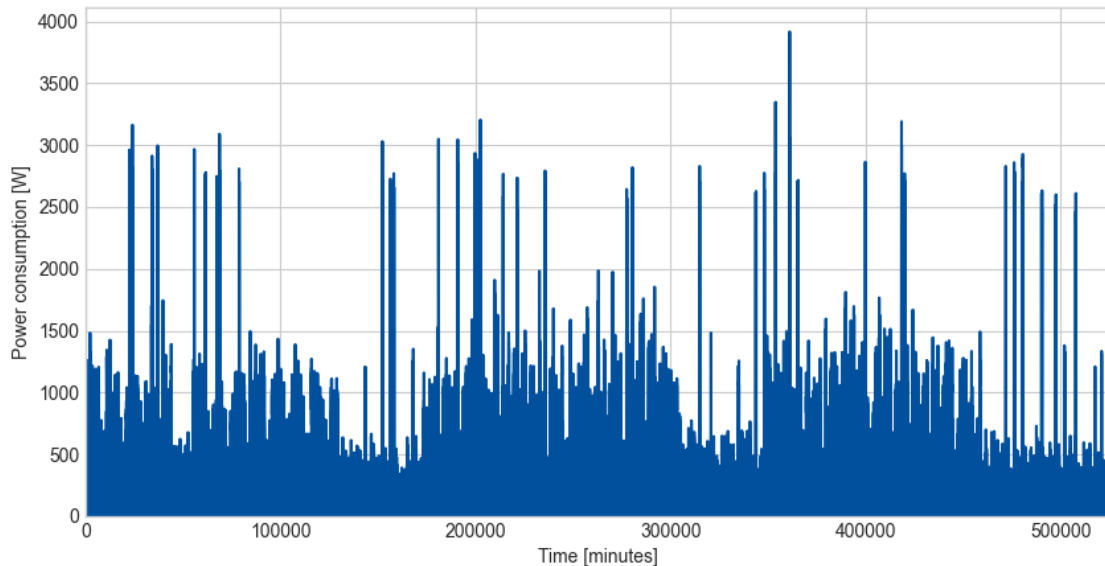

Figure 65: Annual minute based load profile for initial cluster for Cluster 3.

Figure 65 shows that the school schedule highly affects the load profile. This is because all buildings in the cluster have variations in the user behavior related to the vacations. The load profile also

has some significant peaks due to high power appliances in the Workshop.

## Simulations

For Cluster 4, an azimuth of  $-50^\circ$  and roof angle of  $6.2^\circ$  is chosen in accordance with values found for Class 5 during fieldwork. Figure 66 shows the simulation results for different system solutions for autonomy and unmet demand. Excess energy is included in the graph for unmet demand, as this system does not entail any additional costs as the PV panels are already bought and installed.

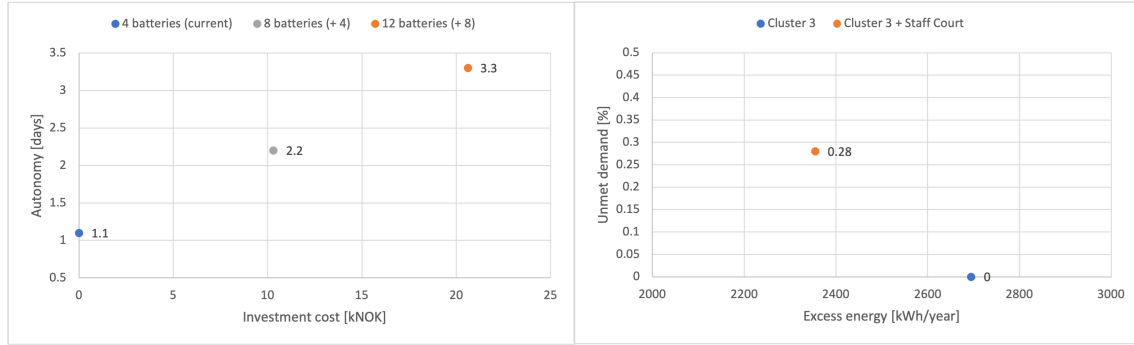

(a) Autonomy.

(b) Unmet demand and excess energy.

Figure 66: Simulation results for different system solutions in Cluster 4.

First, the autonomy of the current system is evaluated, which is illustrated in Figure 66a. It is found that the autonomy is only 1.1 days, which is considered to be a low value. Therefore several batteries are added to the simulation. Adding 4 extra batteries gives an autonomy of 2.2 days, while adding 8 extra batteries achieves an autonomy of 3.3 days. The autonomy of 2.2 days is chosen as the most viable option, given that it is proposed that 4 additional batteries are installed in this cluster to achieve improved performance.

Next, the unmet demand of the current system with the defined cluster is evaluated. It is found to be 0 %, i.e., all the energy demand is met. This can indicate that the system is too big for the given energy demand. Therefore the amount of excess energy is checked. It is found that the current system solution with the defined load gives excess energy of 2,695 kWh per year, i.e., 50 % of the available load. Excess energy is considered unavoidable for the cluster due to the annual variations and peak loads in the load profiles, as shown in Figure 65. However, it is considered that the cluster might have the capacity to supply an additional building, which therefore is tested. This is shown in Figure 66b. Out of the buildings that are not included in the cluster, the Staff Court is the closest building to Class 5. Hence, a new aggregated load profile with the Staff Court is generated. This gives an additional load of 546 kWh per year. The simulation results when including the Staff Court in Cluster 3 gives an unmet demand of 0.28 % and annual excess energy of 2,355 kWh per year, i.e., 40 % of the available energy.

Even though the cluster could include the Staff Court, it is decided to keep it as initially defined. This is because the Staff Court is close to the assumed location of the Computer Lab, which will be simulated to hold the PV panels in Cluster 5. Therefore, it is found that it would not make sense to have cables from class 5 to the Staff Court. Additionally, the capacity of the current controller of 3,500 W is too low to supply the peak load of 3,917 W. It is therefore not desirable to include even more electricity demands.

Conclusively the system solution offering the best compromise between investment cost and performance for Cluster 4 is with 4 additional lead-acid batteries and the existing 7 PV panels. This entails an investment cost of about 10,000 NOK.

---

### 7.5.5 Cluster 5 simulations

Cluster 5 contains the remaining buildings in the teaching area, and will be supplied by a new PV system. The cluster includes Kindergarten 1 and 2, Class 1 and 2, the Staff Court and school toilets. Cluster 5 will include the Computer Lab as well. It is assumed that the PV panels will be placed on this building, as this is assumed to be placed in the middle of the cluster. Figure 67 illustrates the buildings included in Cluster 5 in orange and the suggested PV panel placement.



Figure 67: Cluster 5 in orange with PV panels on the Computer Lab.

Source: J. Lervik 2022.

### Energy demand

The annual energy demand for Cluster 5 is found to be 2,106 kWh, and the plot for the aggregated annual load profile is shown in Figure 68.

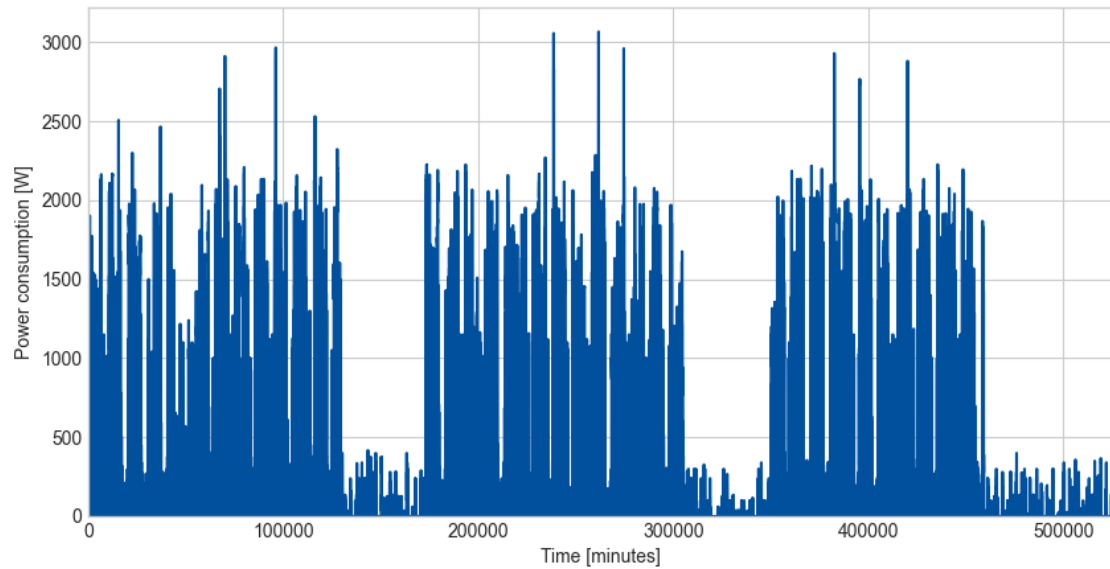

Figure 68: Annual minute based load profile for Cluster 5.

Figure 68 shows that Cluster 5 has significant variability in the load profiles throughout the year. This is due to the change in activity levels in the school vacations, as the load profile is very dependent on the teaching activities in the Computer Lab. The only electricity demands during the vacations are the few laptops that are assumed to be used sporadically by the local community.

### Simulations

As the PV panels are assumed to be placed on the Computer Lab when it is built, the azimuth and tilt angle is set to  $0^\circ$  and  $10^\circ$ . Figure 69 shows the simulation results for different system solution.

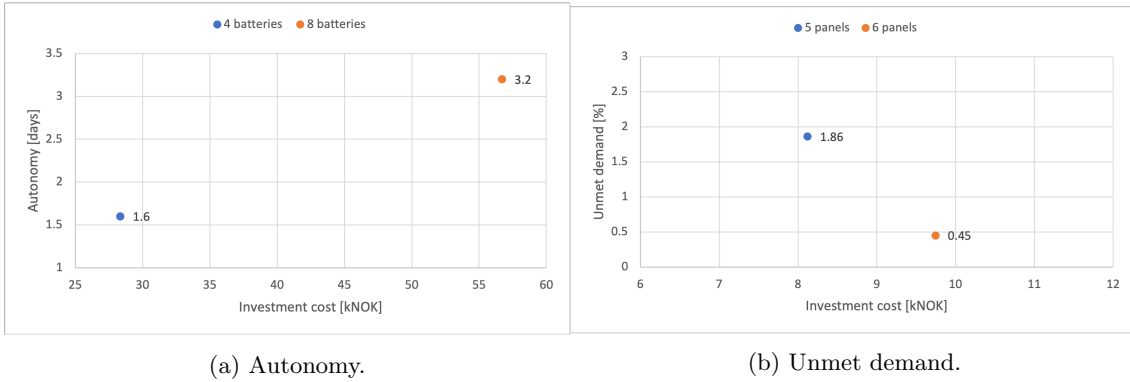

Figure 69: Simulation results for different system solutions in Cluster 5.

Figure 69a shows that system solutions with 4 and 8 batteries give respectively 1.6 days and 3.2 days of autonomy. This is considered respectively too low and too high compared to the desired value of 2 days. The school activities are considered important, and should therefore not be affected by an underdimensioned system. This is especially accurate for the Computer Lab, as teaching depends on electricity supply. Hence, Cluster 5 must have a sufficient autonomy. Thus it is concluded that the additional cost for the heightened autonomy is worth the significant increase in performance, and the solution with 8 batteries and 3.2 days of autonomy is chosen for Cluster 5.

Further, Figure 69b shows that system solutions with 5 and 6 PV panels give unmet demands of respectively 1.86 % or 0.45 %. The first option is close to the maximum limit set for unmet demand. To ensure that teaching in the Computer Lab is reliable, this solution is dismissed. Hence the additional cost to get a significantly improved performance is found acceptable, and the solution with 6 panels and 0.45 % unmet demand is chosen. The annual excess energy is 2,397 kWh, i.e. 53 % of the annual available energy. This is significant and is due to the annual variations due to school vacations, as shown in Figure 68. However, it is found more important to have a sufficient value for the unmet demand rather than lowering the excess energy. Hence, this solution is chosen.

Conclusively the system solution offering the best compromise between investment cost and performance for Cluster 5 is with 8 batteries and 6 PV panels. This gives an investment cost of 66,000 NOK. In addition, the peak load of 3,066 W gives an investment cost of 17,623 NOK for the controller and inverter. Thus, the total investment cost for Cluster 5 is about 83,600 NOK.

### 7.5.6 Cluster 6 simulations

Cluster 6 includes the multi-purpose building. This building is decided to simulate as its own cluster because it is assumed to be built at a long distance from the other buildings at the property. As this is the only building in the cluster, the PV panels are assumed to be placed on the multi-purpose building. Figure 70 illustrates the Cluster 6 and the PV placement.





Figure 70: Cluster 6 in yellow with PV panels on multi-purpose building.

Source: J. Lervik 2022.

### Energy demand

The annual electricity demand for Cluster 6 is 588 kWh, and hence this is a relatively small load. The plot of the annual load profile is presented in Figure 71.

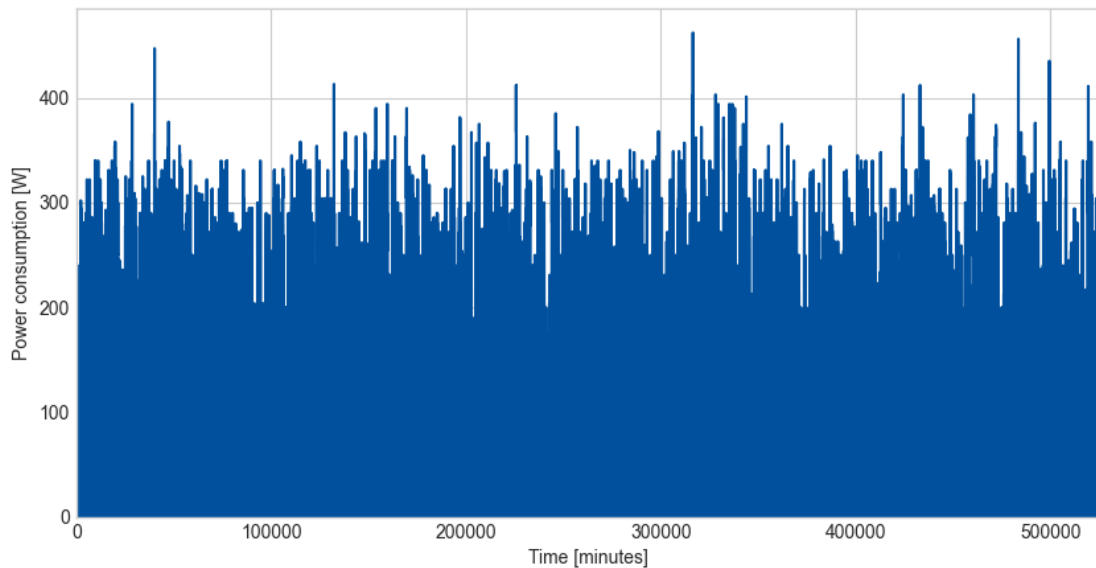

Figure 71: Annual minute based load profile for Cluster 6.

The figure shows that the load is relatively even without any significant annual variations.

### Simulations

Due to the small load, and according to the nominal voltage sensitivity analysis performed in Chapter 7.4.2, it is decided to use voltage level of 13 V for the battery pack in Cluster 6. Further, the azimuth and plane tilt is set to respectively  $0^\circ$  and  $10^\circ$  as the building is not yet built.

Figure 72 shows the simulation results for different system solutions for autonomy and unmet demand for Cluster 6.

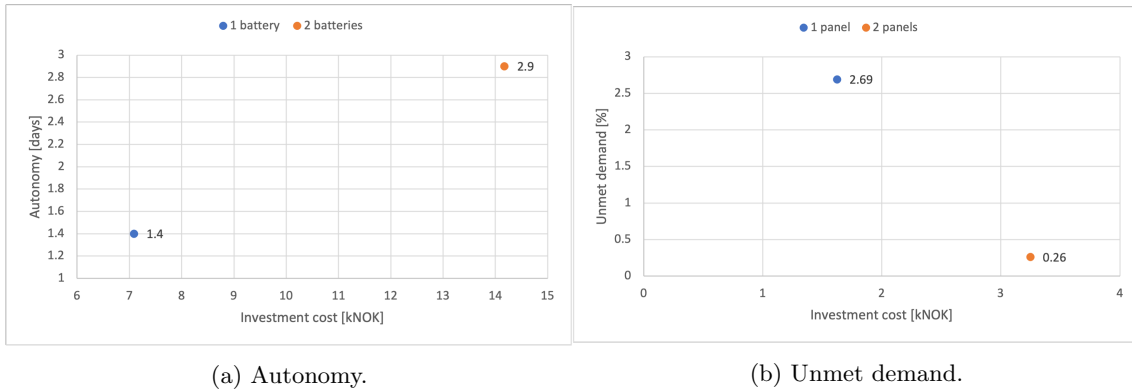

Figure 72: Simulation results for different system solutions in Cluster 6.

Figure 72a shows that system solutions with 1 and 2 batteries give respectively 1.4 days and 2.9 days of autonomy, which is considered respectively too low and too high. However, the multi-purpose building only includes loads that are not considered critical, i.e., fans, lights, speakers, and phones. The activities here are also not considered critical. Therefore it is decided that the higher performance is not worth the additional cost. Conclusively, an autonomy of 1.4 days is considered acceptable for Cluster 6.

Further, Figure 72b shows system configurations with 1 and 2 PV panels gives unmet demands of respectively 2.69 % and 0.26 %. Based on the same arguments as for the autonomy, i.e. that loads and activities are not critical, the high unmet demand of 2.69 % is considered acceptable for Cluster 6.

Conclusively the system solution offering the best compromise between investment cost and performance for Cluster 6 is with 1 battery and 1 PV panel. This gives an investment cost of 9,000 NOK. In addition, the peak load of 462 W gives a calculated cost of 2,656 NOK for the controller and inverter. Thus, the total investment cost for Cluster 6 is found to be about 11,700 NOK.

### 7.5.7 Non-clustered simulations

The non-clustered solution includes all the buildings and energy demands at the property. The location of the system that will supply this solution will not be proposed. The azimuth and plane tilt is therefore set to respectively  $0^\circ$  and  $10^\circ$ , assuming that a new building is suitable.

#### Energy demand

The annual energy demand for the whole property is found to be 14,999 kWh (15 MWh). The aggregated load profile for all buildings at the property is shown in Figure 73.

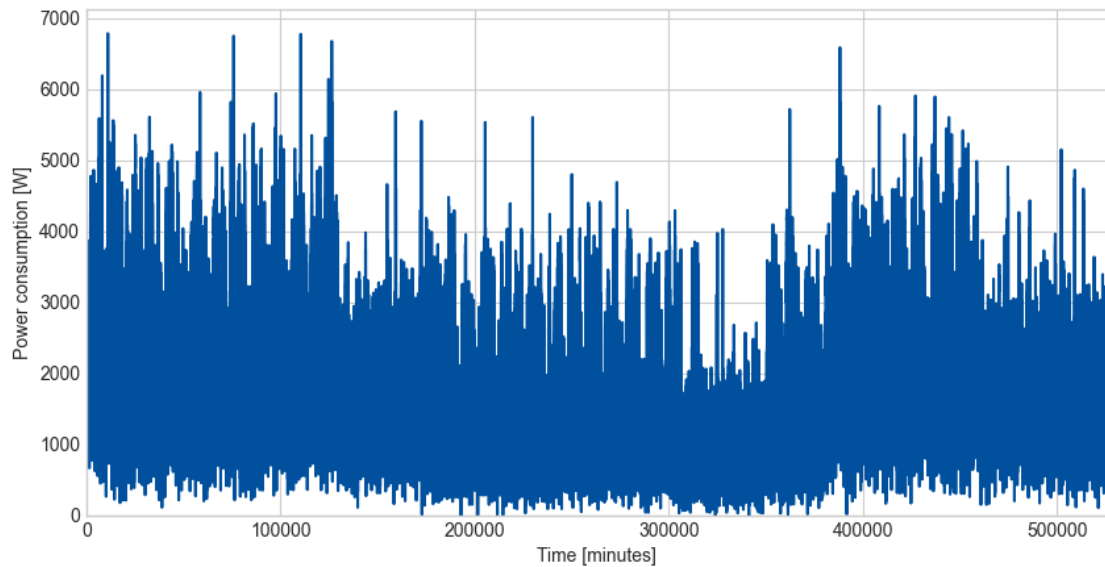

Figure 73: Annual minute based load profile of the non-clustered solution.

The figure shows that there are some significant annual variations in the electricity demands, as well as some significant peak loads. The period between the end of July to the beginning of August especially stands out with a significantly lower load, i.e. about 300,000 minutes to 350,000 minutes. This is due to school vacations combined with an assumed low visitor activity in this period.

### Simulation

Further, for the case that the whole property is to be supplied by one system, a higher autonomy is preferred. This is due to that if the system breaks or have empty batteries, there is no electricity at the site at all. However, to ensure a reasonable comparison to the clustered alternative, the basis for the decision-making should be the same. Therefore, two different system solutions will be made; one with a required autonomy around 2 days and one with a slightly higher value. Figure 74 shows the simulation results for the autonomy of the different system solutions.

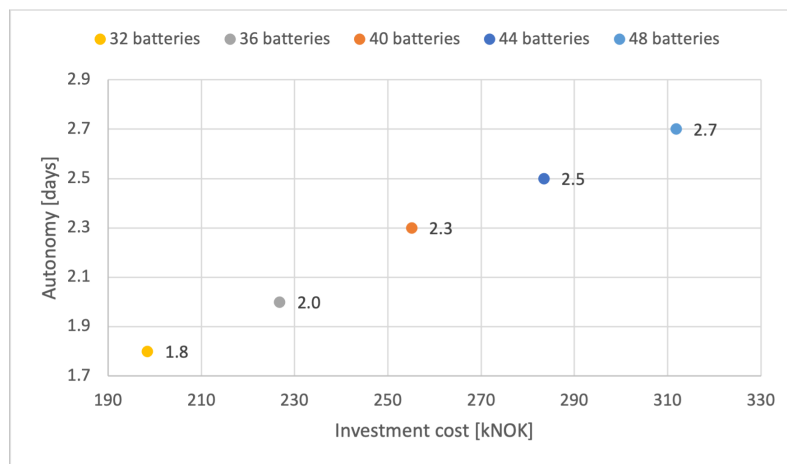
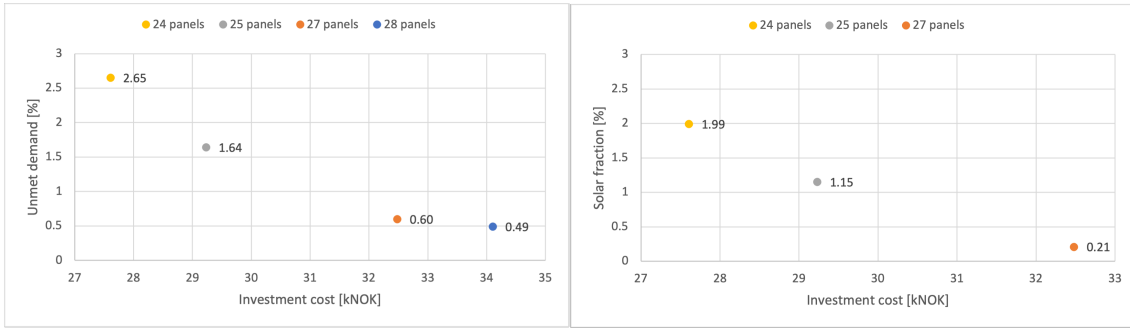

Figure 74: Autonomy results for different system configurations in non-clustered solution.

Figure 74 shows that the autonomies for the different system solutions ranges from 1.8 days to 2.7 days. Solutions with 2.0 days and 2.7 days is chosen for further evaluations. Figure 75a and 75b shows the simulation results for different system solutions in regards to unmet demand with autonomy of respectively 2.0 days and 2.7 days.



(a) Unmet demand with 2.0 days autonomy.

(b) Unmet demand with 2.7 days autonomy.

Figure 75: Unmet demand for different system solutions in Non-clustered solution.

For the non-clustered solution with 2.0 days of autonomy, Figure 75a shows that system solutions with 24, 25, 27, and 28 PV panels give unmet demands of respectively 2.65 %, 1.64 %, 0.60 %, and 0.49 %. The only viable options are the three latter configurations. However, an unmet demand of 1.64 % is considered to be in the higher range of acceptable values and is not further evaluated. For the two latter options, it is found that the most expensive option does not offer a significantly improved performance. Hence, the solution with 27 PV panels and 0.6 % unmet demand is chosen for the non-clustered solution with 2.0 autonomy. The solution has 4,968 kWh excess energy per year, i.e., 24 % of the annual available energy. Conclusively, it is found that the system solution offering the best compromise between investment cost and performance for a non-clustered solution with 2.0 days of autonomy is with 36 batteries and 27 PV panels. This gives an investment cost of about 259,000 NOK. In addition, the peak load of 6,786 W gives a calculated investment cost of 39,000 NOK for the controller and inverter. Thus, the total investment cost for the non-clustered solution with 2 days of autonomy is about 298,000 NOK.

For the non-clustered solution with 2.7 days of autonomy, Figure 75b shows that system solutions with 24, 25, and 27 PV panels give unmet demands of respectively 1.99 %, 1.15 %, and 0.21 %. The first is in the maximum range of the accepted values and is therefore not chosen. For the two remaining options, the latter offers an improved unmet demand of almost 1 % for the cost of 3,000 NOK. It is evaluated that this additional cost is worth the improved performance. This solution has total excess energy of 4,885 kWh/year, i.e. 24 % of the total annual available energy. Conclusively, it is found that the system solution offering the best compromise between investment cost and performance for the non-clustered solution with 2.7 days of autonomy is with 48 batteries and 27 PV panels. This gives an investment cost of about 344,000 NOK. With the additional cost of 39,000 NOK for the controller and inverter, a total investment cost for the Non-clustered solution with 2.7 days of autonomy is found to be about 383,000 NOK.

## 7.6 Backup evaluation: grid connection

The evaluations of a system with grid connections as backup is to be presented in this chapter. This entails an evaluation of the additional costs, possible revenue, and CO<sub>2</sub> emissions associated with grid connection. Figure 76 shows a system topology for grid connected systems. This is a simplified topology as it is not a part of the scope to determine the connection points and whether the distribution system is single- or three-phase.

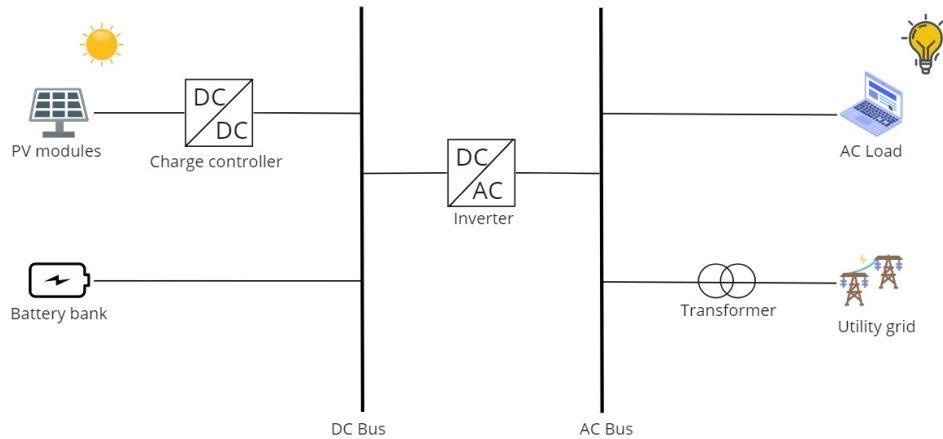

miro

Figure 76: System topology for grid connected system.

For these evaluations, it is assumed that the whole property will get supplied if a grid connection is to happen. Two scenarios will be evaluated, whereas the first will have no additional PV systems or batteries installed at the property. This gives that only the current PV system installed on Class 5 is used for PV production and self-storage. The utility grid will supply the remaining energy demand. The second scenario is a PV system that can supply most of the energy demand at the property through the additional installation of PV panels and batteries. This gives that the utility grid will act as backup for the PV system. The system configuration found for the non-clustered solution with 2.0 days of autonomy will be used for this scenario. This is because the additional performance of 2.7 days of autonomy is not needed when the utility grid acts as a backup. Additionally, evaluations with and without sale of excess energy to the utility grid are performed. To summarize, the following scenarios will be used for the assessment of grid connection:

- grid connection with system size as found in non-clustered solution with 2 days autonomy with and without sale of excess energy to utility grid.
- grid connection with the current system at Class 5 with and without sale to utility grid.

For both scenarios, it will be assumed that all unmet demand found in off-grid simulations in PVsyst will be met by electricity from the utility grid. This amount will be used to find the annual operations costs and the CO<sub>2</sub> emissions. The annual operation costs is found by multiplying the amount consumed from the utility grid by the electricity price. The CO<sub>2</sub> emissions is calculated by multiplying the amount of consumed energy by the emission per kWh. For the cases with the sale of excess energy to the utility grid, it will be assumed that all excess energy found in off-grid simulations in PVsyst will be injected into the grid. The possible revenue is found by multiplying the injected electricity with the feed-in tariff. Therefore, information about the electricity price and feed-in tariff is needed for the grid connected evaluations, as well as CO<sub>2</sub> emissions related to each kWh consumed from the utility grid. The cost of getting connected to the utility grid in the first place also needs to be obtained.

### Consumption and feed-in tariff

The consumption tariff, which is the cost for consuming electricity from the utility grid, is based on the current electricity price in Kenya, which for May 2022 is equal to 1.32 NOK per kWh (Stimatracker 2022). This price includes all surcharges.

As for the feed-in tariff, it is currently only possible to inject power to the Kenyan utility grid if the

production exceeds 500 kW. However, conversations with Chloride Exide indicates that it could also be possible for smaller producers in the near future. A further indication of this is that it is possible in several neighboring countries, such as Uganda and Tanzania. It is therefore considered reasonable to assume that if the sale of excess energy becomes possible in Kenya, the feed-in tariffs will be in the same range as the ones for Uganda and Tanzania. In Tanzania, the annual average feed-in tariff is 0.46 NOK per kWh (IEA 2022a). Uganda, on the other hand, has a significantly higher and more generous feed-in tariff at 1.58 NOK per kWh (Oloya et al. 2021). The average between these two prices is used for the evaluation of grid connection, giving a feed-in tariff of 1.02 NOK per kWh.

### Grid connection cost

Information about the grid connection cost is obtained through conversations with REREC. The cost of getting connected to the utility grid in Kenya depends on several factors, such as the distance to the utility grid and if there is a transformer in the area. REREC assume that for Eco Moyo, this cost will be approximately in the range between 161,000 NOK to 199,000 NOK. These costs include materials such as transformers, poles, conductors, design, supervision, labor, and transportation. However, the authors find a high uncertainty related to these given costs. This is because these values are significantly higher than what has been found in research. (Hansen and A.Xydis 2020, p.257-258) presents that the cost for getting connected to the national grid in Kenya is approximately 3,200 NOK. Additionally, during the fieldwork, a grid connection cost of 1,400 NOK was given by locals. This was the price for grid connection for buildings for domestic use, and conversations gave that the price for a school is probably higher. However, the price given by REREC is used for the grid connection evaluations as this is the most updated and reliable answer obtained. A price in between the range is chosen, which gives a grid connection cost of 180,000 NOK for Eco Moyo.

### CO<sub>2</sub> emissions

To calculate the CO<sub>2</sub>-emissions related to the possible connection to the grid, the CO<sub>2</sub> emission related to the production of the electricity from the utility grid needs to be obtained. Due to the high renewable share in the Kenyan power production, this value is relatively low and found to be approximately 116 grams CO<sub>2</sub> per kWh (Laconde 2022, p.3).

#### 7.6.1 Results for grid connection as backup

Table 44 shows the data for unmet load and excess energy used for the grid connection evaluations, as well as the resulting operation costs, possible revenue, CO<sub>2</sub> emissions, and investment costs for both scenarios.

Table 44: Results with grid connection with non-clustered solution and current system.

Parameter		Non-clustered	Current system
Unmet demand	[kWh/yr.]	89	10,341
Operation cost	[NOK/yr.]	117	13,650
Excess energy	[kWh/yr.]	4,968	48
Revenue	[NOK/yr.]	5,067	49
CO <sub>2</sub> emissions	[kg CO <sub>2</sub> /yr.]	10	1,200
Investment cost	[NOK]	519,665	180,055

For the non-clustered solution, the unmet load is only 89 kWh per year. This is because most of the electricity demand is met by the PV system. This gives a low operation cost of 117 NOK per year, as well as an emission of 10 kg CO<sub>2</sub> per year. The excess energy is however relatively high, with a value of 4,968 kWh per year, resulting in a possible revenue of 5,067 NOK per year. The solution has a high investment cost at 519,665 NOK due to costs both for installation of the extended PV system as well as the grid connection.

On the other hand, 10,341 kWh is consumed from the utility grid per year for the current system

solution. This is because of the low PV generation and battery storage at the property. However, 31 % of the electricity demand is covered by solar energy while the utility grid covers the remaining 69 %. This gives a resulting annual operation cost of 13,650 NOK and annual emissions of 1,200 kg CO<sub>2</sub>. For this solution, the annual excess energy is much lower at only 48 kWh, which gives a negligible revenue possibility of 49 NOK per year. However, this solution's investment cost is relatively low at 180,000 NOK, as it does not include the costs of more PV system installations.

## 7.7 Backup evaluation: off-grid with diesel generator

As for grid connection, off-grid system solutions with diesel generators as backup are evaluated to offer a thorough and complete system evaluation. This entails evaluating the additional costs and CO<sub>2</sub> emissions associated with the use of diesel generators. This evaluation is done by off-grid PVsyst simulations with a defined backup system. Each cluster will be simulated with the off-grid system solution as found to be the optimized for the given cluster in Chapter 7.5. This is used to see if it could be beneficial with a diesel generator at that specific cluster.

Figure 77 shows the system topology for off-grid systems with backup generator. The presented system topology applies to diesel generator evaluations.

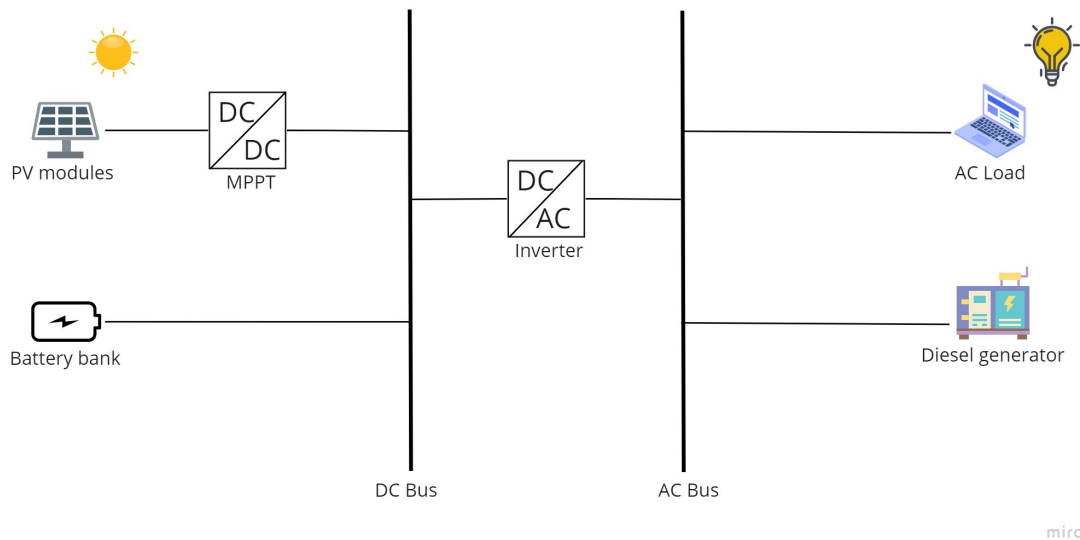

Figure 77: System topology for off-grid system with diesel generator.

### 7.7.1 Additional model input for backup simulations in PVsyst

To simulate for diesel generator as backup, PVsyst requires the nominal and operating power. PVsyst has three diesel generators in the component database, with nominal powers of 1.5 kW, 3 kW, and 5.5 kW. As the diesel generator evaluations are simplified evaluations to get an impression of the magnitude of the impacts of this backup solution, it is found that using the most relevant out of these three components for each cluster is acceptable. Therefore, for each cluster, the lowest generator capacity higher than the peak load will be chosen. As for the effective operating power, it is set to 70 % based on recommendations from (Wiemann et al. 2014, p.58).

In order to calculate the investment costs it is necessary to set a price for the 1.5 kW, 3.0 kW, and 5.5 kW backup diesel generators. For this the prices on a Norwegian website are used, and is assumed to be in approximately the correct range due to that the Norwegian prices and Chloride Exide's prices are in the same range (Solry 2022b, ChlorideExide 2022b). Therefore the price for a 3.0 kW diesel generator is set to 4,489 NOK, and for a 5.5 kW diesel generator it is set to 9,789

NOK (Bygg 2022a, Bygg 2022b). For the 1.5 kW diesel generator the average price per kW for the two other diesel generators is used, giving a resulting price of 2,2457 NOK.

To determine the operating costs due to fuel consumption with a backup generator, it is necessary to set a fuel price. This is, however, a complex task due to the currently unstable situation globally because of the Covid-19 pandemic and the war in Ukraine. These factors have resulted in high diesel prices. It is not known how the prices will develop in the following years. Based on the high uncertainty related to these events, the average fuel price in Kenya between 1990 and 2021 fuel price is used as input, which is found to be 10.97 NOK per L consumed (FXEmpire 2022). Finally it is assumed that diesel engines has CO<sub>2</sub> emissions equal to 2.7 kg per L consumed (NRCAN 2022).

### 7.7.2 Results for diesel generator backup

Figure 78 shows an overview of the resulting annual backup energy, fuel consumption, emissions and operating costs for all clusters as output from PVsyst.

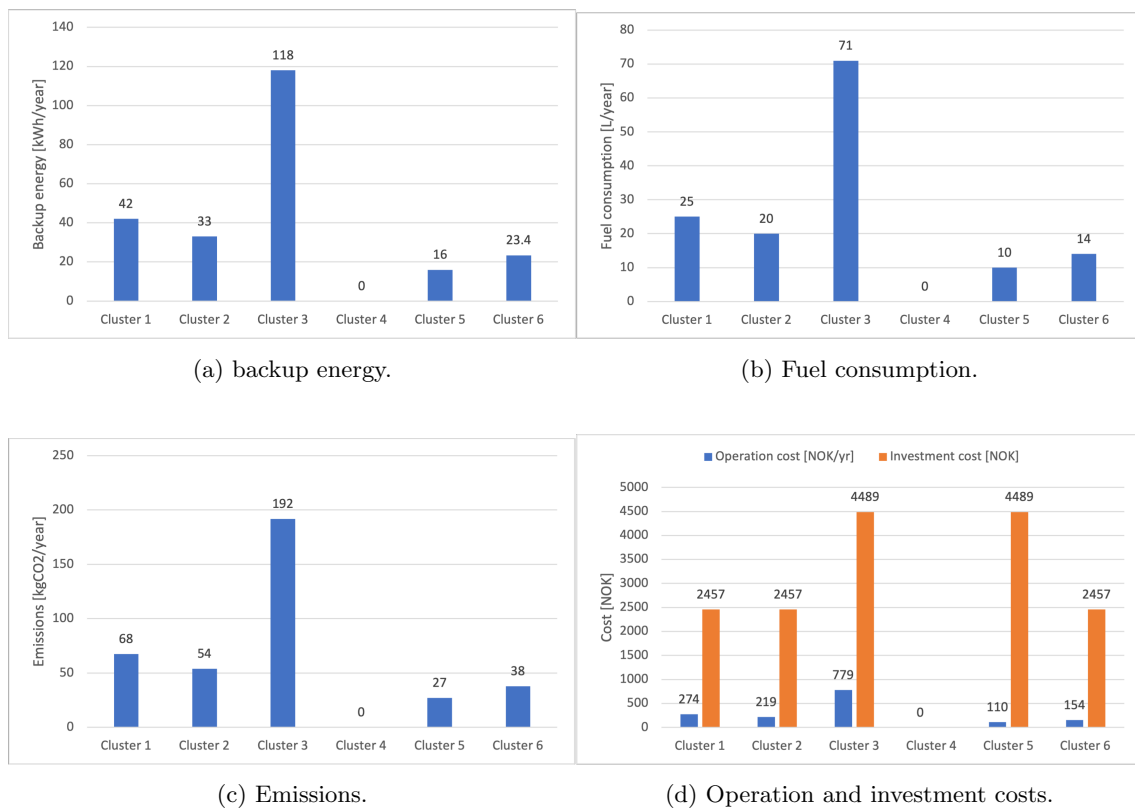

Figure 78: Results from diesel generator backup solution.

The figure shows that Cluster 3 has the most considerable use for a backup generator, with 118 kWh covered by the diesel generator each year. This results in an annual emission of 192 kg CO<sub>2</sub> and an operation cost of approximately 800 NOK for the fuel. Cluster 4, however, has zero energy that is covered by the diesel generator due to an unmet demand for the off-grid system solution equal to 0 kWh. The remaining clusters are in between this range, and the results will be further discussed in Chapter 9.4.



---

## 8 Results

In this section the results for the system solutions obtained for all clusters in Section 7 is presented. These results are related to performance and investment costs, as well as an overview of the resulting components needed for each solution. The results for all clustered and non-clustered solutions will be presented. Figure 79 shows an overview of the clusters with the suggested PV panel placements.



Figure 79: Overview of clusters with PV panel placements.

Source: J. Lervik 2022.

### 8.1 Economic results

The economic results entail the investment costs due to PV panels, batteries, controllers and converters. The investment costs for each cluster is presented, as well as total investment costs for the clustered and non-clustered solutions. This is presented in Figure 80.

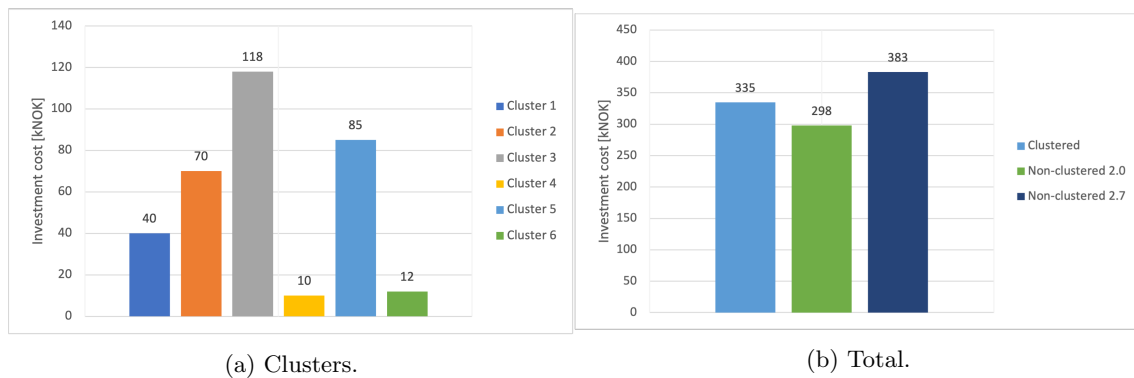

Figure 80: Resulting investment costs for all system solutions.

#### Clusters

The investment costs for all the individual clusters are shown in Figure 80a. It can be seen from the figure that Cluster 3 stands out as significantly more expensive than the other clusters, while Cluster 4 and 6 are prominently cheaper. The low cost for Cluster 4 is because this solution only entails upgrading the existing PV system.

#### Clustered and non-clustered solutions

The total investment costs for the clustered and non-clustered solutions are shown in Figure 80b. The figure shows that the non-clustered solution with 2.0 days of autonomy has the lowest investment cost, while the non-clustered solution with 2.7 days of autonomy is the most expensive

option. Lastly, the clustered solution provides an investment cost in between the two non-clustered solutions.

## 8.2 Performance results

The performance results entail the unmet load, excess energy, and autonomy. These parameters are presented for all of the individual clusters, as well as the total performance results for the clustered and non-clustered solutions.

### 8.2.1 Unmet demand

The unmet demand for all the clusters and system solutions are presented in Figure 81.

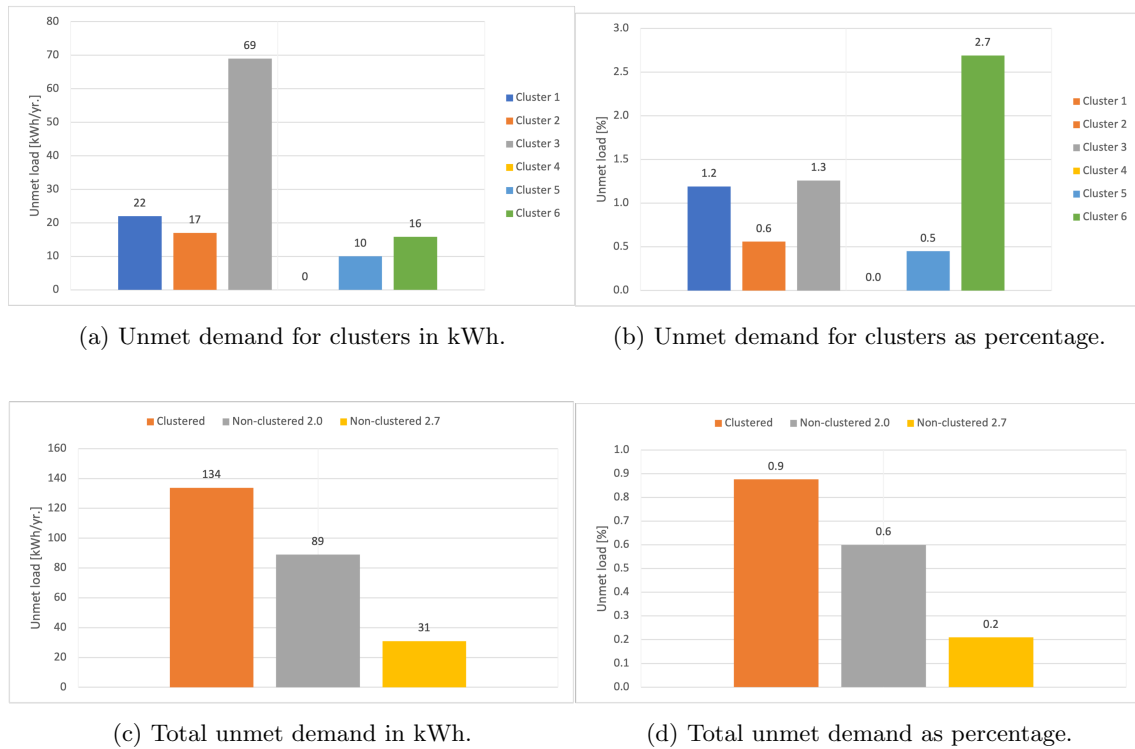

Figure 81: Results for unmet demand for all system solutions.

### Clusters

The unmet demand for all the clusters in kWh and as percentage of the total energy demands are presented in respectively Figure 81a and 81b. The first figure gives that Cluster 3 has a significantly higher unmet demand in kWh than the remaining clusters. However, this does not entail a significantly higher percentage of the total energy demand in the cluster than for the other clusters. This cluster and Cluster 1 have approximately the same value for unmet demand as a percentage at 1.2 % and 1.3 %. Cluster 2 and Cluster 5 have relatively low values for unmet demand at 0.6 % and 0.5 %. Finally, Cluster 6 has the highest value for unmet load at 2.7 %, while Cluster 3 has the lowest with a value of 0 %.

### Clustered and non-clustered solutions

The total unmet loads for the clustered and non-clustered solutions in kWh and as percentage of the total energy demand are presented respectively in Figure 81c and 81b. The figures show that the non-clustered solutions have slightly better values for unmet demand equal to 0.6 % and 0.2 % compared to the 0.9 % for the clustered solution.

## 8.2.2 Excess energy

The unmet demand for all the clusters and all system solutions are presented in Figure 82.

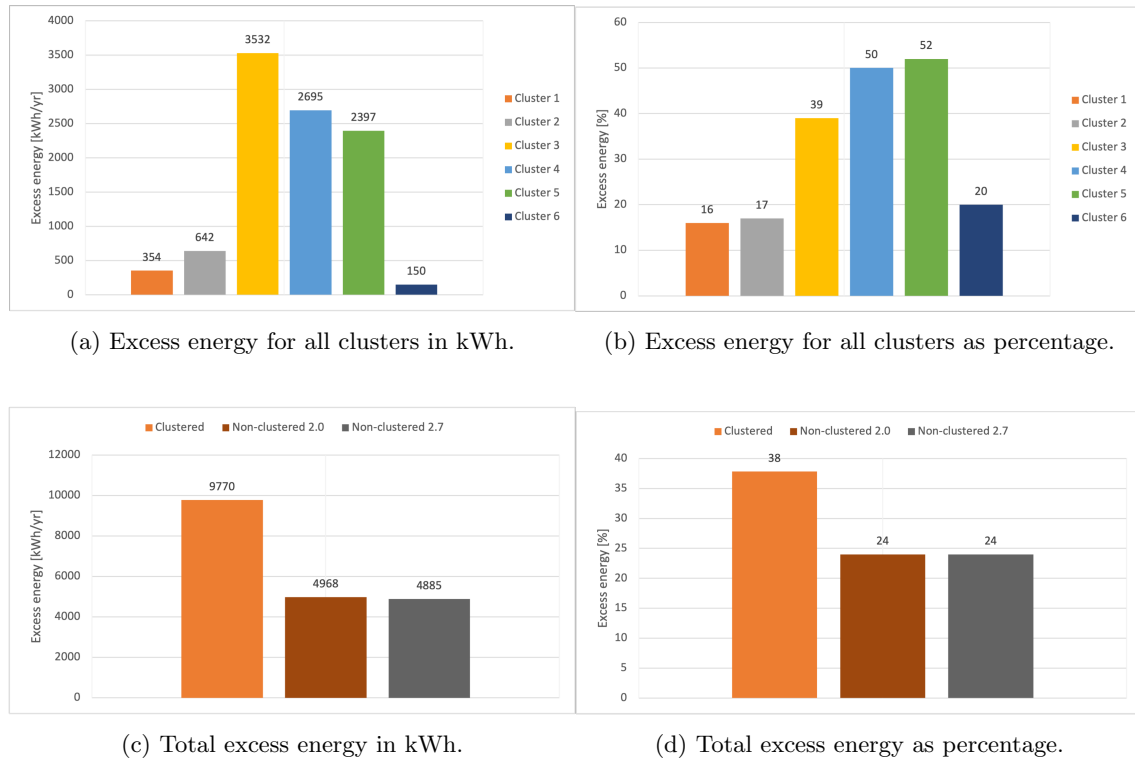

Figure 82: Results for excess energy for all system solutions.

### Clusters

The excess energy for all clusters as an amount of kWh and as a percentage of the total available electricity in each cluster is presented in respectively Figure 82a and 82b. It can be seen from the figures that Clusters 3, 4, and 5 have significantly higher values for excess energy than the remaining clusters. These amounts account for a significant part of the total available electricity at the clusters, respectively 39 %, 50 %, and 52 %. The remaining clusters have significantly lower values, accounting for between 16 % to 20 % of the total available energy at each cluster.

### Clustered and non-clustered solutions

The total excess energy for the clustered and non-clustered solutions as amount in kWh and percentage of the total available energy in the given solution is presented in respectively Figure 82c and 82d.

The figures give that the clustered solution gives twice as much excess energy in kWh per year compared to the non-clustered solutions. This accounts for 38 % of the total available electricity in the clustered solution, while a significantly lower value of 24 % for both non-clustered solutions.

## 8.2.3 Autonomy

The autonomy for all the clusters and the non-clustered solutions are presented in Figure 83.

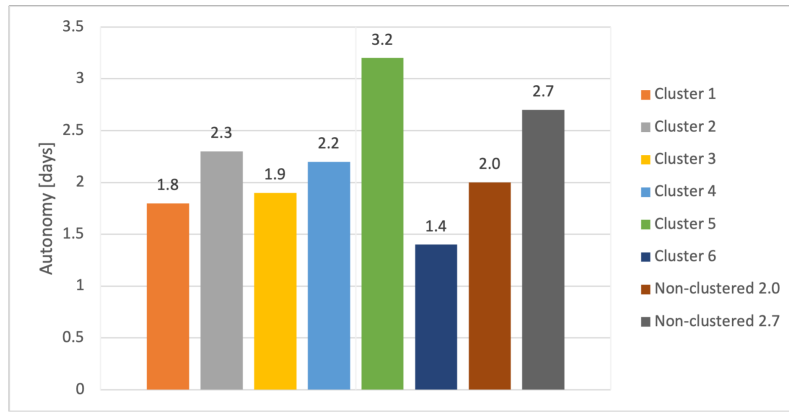

Figure 83: The autonomy of all clusters and non-clustered solutions.

The figure shows that Cluster 4 has a significantly higher value than the others with 3.2 days of autonomy, and the value for non-clustered with 2.7 days of autonomy is also slightly higher. Cluster 5, on the other side, has a significantly lower value with only 1.4 days of autonomy. The remaining clusters have autonomies totalin the range between 1.8 days and 2.3 days.

### 8.3 Component results

The component results entail the amount of PV panels and batteries needed for all of the individual clusters and non-clustered solutions. This is summarized in Figure 84.

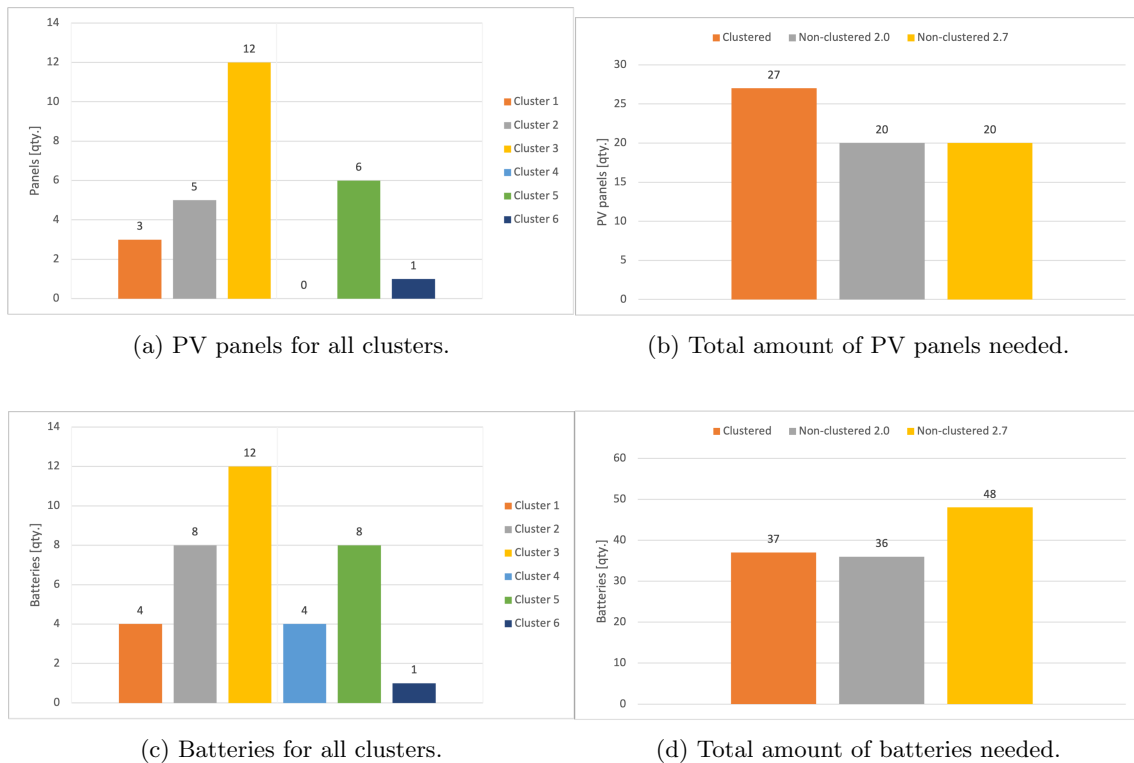

Figure 84: Results for required PV panels and batteries for all system solutions.

#### PV panels

The amount of PV panels needed for each individual cluster is presented in Figure 84a, while the

total amount of PV panels needed for the clustered and non-clustered solutions is presented in Figure 84b. The latter shows that the clustered solution require 27 PV panels in total, while both non-clustered solutions require 20 panels. The needed areas for each cluster as well as total for the clustered and non-clustered solutions are presented in Table 45, based on numbers given from PVsyst.

### Batteries

The amount of batteries needed for each individual cluster is presented in Figure 84c, while the total amount of batteries needed for the clustered and non-clustered solutions is presented in Figure 84d. The latter shows that the clustered solution require 37 batteries in total. Further, the non-clustered solution with 2.0 days of autonomy requires 36 batteries while the non-clustered solution requires 48 batteries. The needed areas needed for each cluster as well as total for the clustered and non-clustered solutions are presented in Table 45, based on the dimensions given in the data sheet in Appendix A.1.

## 8.4 Summary of system solutions

Table 45 shows a summary of the results for the final system solutions for each cluster, as well as for the clustered and the non-clustered solutions. The total clustered solution is referred to as C in the table, and the non-clustered solutions with 2.0 days and 2.7 days of autonomy as respectively NC2.0 and NC2.7.

Table 45: Summary of results.

<b>Parameter</b>	<b>1</b>	<b>2</b>	<b>3</b>	<b>4</b>	<b>5</b>	<b>6</b>	<b>C</b>	<b>NC2.0</b>	<b>NC2.7</b>
Batteries [qty.]	4	8	12	4	8	1	37	36	48
Battery area [m <sup>2</sup> ]	0.35	0.70	1.05	0.35	0.70	0.09	-	3.15	4.20
PV panels [qty.]	3	5	12	0	6	1	27	20	20
PV panel area [m <sup>2</sup> ]	7	11	27	0	13	2	-	60	60
Unmet demand [%]	1.2	0.6	1.3	0.0	0.5	2.7	0.9	0.6	0.2
Excess energy [%]	16	17	39	50	52	20	38	24	24
Autonomy [days]	1.8	2.3	1.9	2.2	3.2	1.4	-	2.0	2.7
Investment cost [kNOK]	40	70	118	10	85	12	335	298	383

---

## 9 Discussion

In this section, a discussion of the results and other considerations will be done in order to make a system proposal selection. The main objective is to make a recommendation in regards to a clustered or non-clustered solution. Furthermore, a discussion of the system solutions with grid connection and diesel generators as a backup will be presented. Finally, moments of uncertainty will be presented.

### 9.1 Result discussion

In this chapter, the results presented in Chapter 8 will be discussed. The discussion will entail the system investment costs, performance, and needed components. Table 45 will be used as a basis for the result discussion. It shows the excess energy and unmet demand, the autonomy, investment costs, and components quantity.

#### 9.1.1 Non-clustered with 2.7 days autonomy

The results give that the non-clustered solution with 2.7 days of autonomy is the most expensive system solution, with an investment cost of 383,000 NOK. It includes an investment cost that is 48,000 NOK more expensive than the second most costly option, which is the clustered solution. It is 85,00 NOK more expensive than the cheapest solution, which is non-clustered with 2.0 days of autonomy. This higher investment cost is due to a higher amount of components compared to the other system solutions. It especially has a high amount of batteries, which is set as the most expensive component in this master thesis. This high amount of components also results in the solution with the highest performance. The unmet demand is only 0.2 % of the total electricity demand, the lowest of all solutions. The excess energy of 24 % is also significantly lower than for the clustered solution. The autonomy of 2.7 days is also the second-highest value found for all clusters and systems solutions.

Conclusively, it is found that the non-clustered solution with 2.7 of days autonomy is the solution that offers the best performance, but also the highest investment cost. Hence, if the financial means are available, and the school is willing to use this amount of money on the electricity supply, this non-clustered alternative is preferred.

#### 9.1.2 Non-clustered with 2.0 days autonomy

The results give that the non-clustered solution with 2.0 days of autonomy is the cheapest option, with an investment cost of 298,000 NOK. This is due to the lower amount of PV panels and batteries than the other solutions. The non-clustered solution with 2.0 days autonomy has the same amount of excess energy as the non-clustered solution with 2.7 days autonomy, i.e., 24 % compared to the 38 % for the clustered solution. However, due to the lower amount of batteries, the unmet demand is slightly higher than for the non-clustered with 2.7 days of autonomy, at 0.6 %. It is still lower than that for the clustered solution at 0.9 %.

Conclusively, it is found that the non-clustered solution with 2.0 days of autonomy offers a cheaper system solution with good performance. Therefore this solution stands out as a good alternative if a significant but lower than required investments for the non-clustered with 2.7 days of autonomy, one-time investment is possible.

#### 9.1.3 Clustered

For the clustered solution, the results give that the total investment cost is 335,000 NOK. This is 48,000 NOK cheaper than the non-clustered solution with 2.7 days of autonomy. It is, however 37,000 NOK more expensive than the non-clustered solution with 2.0 days of autonomy. The

---

clustered system solution provides an acceptable performance with 0.9 % unmet demand. The 38 % excess energy is significantly higher than for the non-clustered solutions. The days of autonomy of the clustered system solutions vary between 1.4 and 3.2 days, whereas Cluster 1, 3, and 6 have lower values than the non-clustered options with 2 days of autonomy. Additionally, the clustered alternative offers a more flexible approach, allowing for system expansions as funding is available, avoiding the high one-time investment costs needed for the non-clustered solutions.

Conclusively, it is found that the clustered solution in general provides a slightly lower performance than for the non-clustered solution with 2.0 days of autonomy at a slightly higher cost. However, in general the clustered system solution offers an acceptable system performance for all clusters. Therefore, this solution is recommended if a gradual expansion of the electricity supply is to happen at the school.

## 9.2 Further evaluations

To make a final decision of the recommended system proposals, other considerations than the simulation results must be evaluated as well. Many aspects related to the clustered and non-clustered solutions are already presented in Chapter 7.2, and most of these will not be re-introduced. However, some aspects should be further discussed on the basis of the simulation results as well. These will be further explored in this chapter.

### 9.2.1 Gradual expansions and electricity demands

An advantage with the clustered solution is that it allows for the electricity access to be gradually adjusted to the expansions of the property. As can be seen from the results, the excess energy is significantly higher for the clustered solution. This could entail that if all systems are installed, and the simulation results are accurate, the clustered solution is less cost-efficient in terms of only investing in energy that is needed at the property. However, if the clusters are gradually supplied by electricity, it could allow for more dynamic decision-making for the proposed solutions at the property. This could for instance entail that some systems supply more buildings than planned for, if it is observed that there is enough excess energy throughout the year to expand the clusters.

Additionally, the clustered solution will allow a gradual expansion as the school receives funding. This entails that the possibility of expanding the electricity supply does not have to be limited by the need for obtaining as significant investment capital as for the non-clustered solution. This can allow for expansions to happen in the near future as well. However, it should be noted that the required investment also must cover new buildings for many of the clusters, as the systems are planned to be installed on them. This is accurate for Cluster 3, 5, and 6.

The non-clustered system size is, on the other hand, adjusted to supply a scenario where the future buildings at the property are present. However, it is not known precisely when these buildings will be realized. Hence, there is a possibility that such a system would represent an inefficient investment if some of the expected building projects are not prioritized within the nearest future. Hence, even though the excess electricity is lower for the non-clustered solution, this result might not be accurate until all future building projects accounted for have been built. This could possibly entail several years with too much power production. Such scenarios could be avoided for a clustered solution, as it would be possible to invest in systems gradually as the property expands.

#### Required area

All solutions entail requirements regarding the area that is needed for PV panels and batteries. Hence, building projects would have to be adjusted to these requirements. This is especially accurate for Cluster 3, 5, and 6, as the systems are assumed to be placed on the buildings that are expected to be built in these areas. It is not known whether it is realistic to expect the new buildings to be of the required size. This could make the results less realistic. On the other hand, it could be beneficial that these required areas are known in advance so that there will be an opportunity to adjust the buildings to the proposed solutions. Additionally, it can be seen from

---

the results that the required area for PV panels in the mentioned clusters ranges between 2 and 27 m<sup>2</sup>. Even the largest area of 27 m<sup>2</sup> can be considered feasible if it is placed on the hangout area. This is because this building is expected to house many visitors, and a building of the required size might therefore be needed regardless of the PV panels. Both the Computer Lab and the Multiple Purpose Building are expected to meet the requirements of respectively 13 m<sup>2</sup> and 2 m<sup>2</sup> as well, as both buildings must be large enough to fit at least a class of 30 students.

The non-clustered solution requires an area of 60 m<sup>2</sup> for PV panels, which is larger than for any of the individual system in the clustered solution. If the systems are to be installed in the same area, this might require a new building at the property. The installment could be combined with other solutions, such as a shadowing area, or the planned future building projects. However, if this is not realized, the required area for the installments could entail undesired encroachments at the property.

### 9.2.2 Social aspects

As was experienced during the fieldwork, dissatisfaction regarding which clusters should be prioritized can occur. Therefore, it is important to account for such social aspects when prioritizing electricity access at the property. However, such dilemmas do not have to be leading to a non-clustered solution, as the system would entail equal electricity access at the school.

The economic results present that the least expensive systems for the clustered solutions are for Cluster 1, Cluster 4, and Cluster 6. If the funding is limited, it could be beneficial to prioritize these systems. There is almost no price difference between the solutions with the lowest investment costs, i.e., Cluster 4 and Cluster 6. However, as there is uncertain exactly when the Multiple Purpose Building in Cluster 5 will be built, it is more challenging to plan for the investments in a system on this cluster. Hence, if decisions were made solely on this aspect and the economic results, it seems reasonable to prioritize Cluster 4 if the budget is low.

However, considering social aspects, this could cause undesired dissatisfaction among employees. This is because Cluster 3 already has a functioning system, whereas other clusters do not. Hence, it is recommended to prioritize saving the investments to a more expensive solution in some of the clusters that need electricity or replacements on insufficient solutions. This is to increase the satisfaction of the people at the school, as the distribution of such investments at the property can be considered more fair. As there already is an installed system in Cluster 1, it could, for instance, be beneficial to prioritize Cluster 2. This allows for the old system in Cluster 1 to be utilized until it malfunctions, and the costs of a new system of 40 kNOK can be delayed.

### 9.2.3 Plausibility

The plausibility, i.e., if the solutions make sense in the real world, of the project should be evaluated as well. The plausibility of the system proposal is significantly increased by the experiences that are accounted for from the fieldwork. It is, for instance, known that lithium-ion batteries, inverters, and MPPT controllers are components that are available locally. An additional essential aspect that increases the project's plausibility is that the local company is known to be reliable and able to deliver high-quality solutions. The fact that the system proposals are adjusted to components and solutions that they are known to be able to provide is therefore important to increase the plausibility. This is the case for proposing an AC-coupled microgrid as well, which is adjusted to the current AC load at the property.

However, the plausibility can be negatively affected by factors that can not be known until they are realized in the future. This is especially relevant for the future building projects that are included in the clusters, even though are not currently existing at the property. This affects the plausibility of the clustered system proposals. If future plans develop in a different direction than expected, the plausibility could be reduced. Firstly, this entails that electricity access that is not yet known is accounted for. If, for instance, building projects are rejected, this would entail that the system proposals are sized based on electricity consumption that will never happen. However, if other



---

building projects are included instead, it is possible that the systems could supply these loads. Hence, the plausibility is not necessarily reduced if the buildings are replaced by similar electricity demands.

The distribution of the system components is, on the other hand, highly affected by a scenario where future building projects are changed or rejected. This is especially accurate for the Computer Lab. This is because the system at Cluster 5 is highly dependent on this building. Firstly, the Computer Lab entails a peak consumption that dominates the load profiles of the cluster. Hence, the system would be unnecessarily big for the cluster's other buildings if the Computer Lab is not built. Secondly, the system is planned to be located in the Computer Lab. Therefore, an important basis for including the load of the Staff Court in Cluster 4 was the assumption that the Computer Lab would be placed close to this building. However, there is a high level of uncertainty related to the location of the buildings. The plausibility of the system proposals of this cluster, therefore, decreases significantly if the Computer Lab is located far away from this cluster. The clusters should then be re-evaluated, as they were established on the basis of distances at the property. This can be said for all clusters with future building projects except Cluster 6. This is because the Multiple Purpose Building does not affect other buildings unless a non-clustered solution is chosen.

The expected visitor area depends on whether the hangout-area to be built with enough space for the required system. Otherwise, the new visitor huts must be built with strong enough roofs to have the system installed on them. Hence, this area is affected if future building projects are rejected. On the other hand, however, this area allows for more opportunities to adjust the system distribution, as more buildings are planned to be built. Therefore, it can be considered more plausible and possible to adjust to future scenarios than Cluster 5.

## 9.3 Grid connection

In this chapter, a discussion of whether or not a grid connection could be feasible in the future for the school is presented. The main parameters that are considered in this chapter are investment costs, operation costs, possible revenue, and CO<sub>2</sub> emissions related to a potential grid connection. The evaluations were made with two different scenarios, one with additional PV panel and battery installations, and one without it. These two scenarios will be evaluated individually in this chapter.

### 9.3.1 Current system

The scenario with the current system at Class 5 connected to the utility grid is to function as a reference case. The thought is to see what the costs and emissions would be by not installing any other PV panels and batteries at the property to have an additional indication and perspective of if the PV system proposal is good. The investment cost of this solution is significantly lower than for all the off-grid solutions at 180 kNOK. This is because no additional components need to be installed, and this only includes the cost of grid connection. It was found that a significant amount, 10,341 kWh per year, of the load was not met by the existing system at the school. This will be met by the utility grid, resulting in an annual operation cost of 13,650 NOK and CO<sub>2</sub> emissions of 1,200 kg. One of the main reasons for considering grid connection was for the authors to consider the possibility of an stable source of income for the school. However, as the excess energy for this solution only is 48 kWh per year, resulting in 49 NOK per year, this is not found to be the case. As the school prefers to be self-supplied and wants to keep a green profile, and the solution does not provide any additional sought-after benefits such as significant revenue, this solution is not found to be a suitable option. This is even though the solution is cheaper than all other options. Conclusively, the combination of a complete PV system and grid connection includes very high investment costs and low rewards and is therefore found not to be a viable option. Taking the unreliability that was found to be associated with the local utility grid during the fieldwork into considerations, this decision is substantiated.

---

### 9.3.2 Non-clustered solution

The scenario with the non-clustered solution connected to the utility grid is the most expensive solution in this master thesis. This is because it includes the cost of grid connection as well as all the components needed for the extended PV system. This gives a total cost of 520 kNOK. As the unmet load for this PV system solution is only 89 kWh per year, connecting it to the grid does not provide any significantly improved performance. The low amount of consumed energy from the utility grid also results in low CO<sub>2</sub> emissions at 10 kg per year. However, this solution provides a higher amount of excess energy than the previous solution, with almost 5,000 kWh/year. Still, this only accounts for an annual revenue of slightly over 5,000 NOK, which is insufficient to make the high investment cost worth it. The same arguments regarding the unreliability of the local utility grid is relevant for this solution as well.

## 9.4 Backup diesel generator

In this chapter, a short discussion of whether or not diesel generators as backup solutions can be feasible for the off-grid system solutions found for each cluster. The main parameters that are considered are the investment cost, operation cost, and CO<sub>2</sub> emissions. In general, as the diesel generator evaluations are based on the optimized off-grid system solutions, the performances in all clusters are already found to be high and sufficient. Therefore, for the clusters without critical loads or any particular characteristics that should be noted, these will not be further evaluated.

For Cluster 3 the diesel generator covers the biggest load at 71 kWh per year, bringing the unmet demand down from 1.3 %. This entails an investment cost of approximately 4,500 NOK and annual operations costs of 800 NOK, as well as 192 kg CO<sub>2</sub> emissions. As the unmet demand in the cluster is of a more significant size than the other clusters, it could be a relevant solution in the future if found necessary. This is especially due to that the users in this clusters are visitors that do not know the system and its boundaries well, and are therefore not as capable of implementing a form of user flexibility. Also, it is assumed that some of the users will pay to live there, and therefore expects the systems to work at all times.

For Cluster 4 the unmet demand is 0 % and therefore it is not really relevant with a diesel generator as backup solution for this cluster. However, as the capacity of 3,500 W of the current installed inverter is not sufficient to cover the peak load of 3,917 W, the diesel generator could be used as backup solution for the cluster if problems are experienced.

For Cluster 5 the unmet demand is low, and it is therefore not really found to be necessary with a diesel backup generator. Many of the electrical demands in the area are lights and fans at the school, which is not found critical, as the buildings are built with an architecture allowing for natural lighting and ventilation. However, the electricity demands concerning the Computer Lab are considered critical as they affect school activities. Therefore, if it in the future turns out to be a problem regarding the supply of this building, a possible option is to include a diesel generator.

It should also be noted that the price for one additional PV panel is found to be 1,624 NOK, which is cheaper than the diesel generators used for these evaluations. Therefore, it is a better solution to install an additional PV panel for all the solutions to bring down the unmet demand to 0 % rather than using diesel generators. This is in line with Eco Moyo's green profile. This will, however, not provide any backup security if the PV system malfunctions.

## 9.5 Other considerations

Some other considerations that should be made regardless of the chosen system solution is discussed below.

---

### 9.5.1 Safety and maintenance

An important aspect that should be considered is the level of competence at the property. The lifetime and performance of the system components that are used in the system simulations is based on the assumption that the components are properly used and maintained. However, as was discovered during the fieldwork, no routines were established for maintaining the PV panels. Hence, it is important that proper training and routines are prioritized to ensure that the system is utilized optimally. It is also critical that safety is prioritized when installing new systems at Eco Moyo. It was acknowledged during the field trip that it should not be assumed that safe behavior is practiced at the property. This should affect the choice of components, as well as the location of these.

### 9.5.2 Communication and knowledge-sharing

Due to the low competence level among consumers at the property, proper communication and knowledge-sharing must be ensured. Measures to ensure this can, for instance, ensure that operators' contact information with relevant knowledge and experience (i.e., Chloride Exide) is easily accessible. This would ensure that safety is not compromised if the system needs supervision or fixing. An essential premise for this to be a well-functioning solution is that help is available once summoned. Maintaining a trusting and reliable relationship is also vital, such that people see the value of contacting external support.

Additionally, communication is essential when evaluating plans for new systems. It is important to explain and prioritize to prevent dissatisfaction among people who do not get easy access to new installments. It could also be beneficial to discuss what people need the electricity for to ensure that the appliances invested in are in line with what is needed by the people at the school. This is especially important in buildings that are currently not supplied with electricity. Additionally, good communication and knowledge-sharing can increase individual ownership of the installed systems. This could ensure that the system is used properly.

## 9.6 Uncertainty analysis

Several factors, such as decisions, assumptions, and obtained data, are contributing to the uncertainty of the results that have been obtained. These factors will be discussed in this chapter.

### 9.6.1 Load profiles

As presented, there are several advantages related to the usage of RAMP to establish the load profiles. However, several assumptions have been made to establish the model input. The moments of uncertainty related to these assumptions will be discussed in this chapter.

#### Appliances

To account for future electricity usage, some of the appliances in the load profiles are included even though they are not currently used at the property. The classrooms are, for instance, built to ensure that appliances such as lights and fans are unnecessary. Even though the authors found it reasonable to assume that some lights and fans could improve the teaching environment, people at the property did not express a great need for it during the fieldwork. Hence, it might be unrealistic to assume that these appliances will be prioritized when the electricity supply is improved. However, the electricity consumption is small in the classrooms compared to other buildings in the associated cluster. Therefore, these assumptions should not be a decisive factor in the sizes of the system proposals for these clusters.

The authors registered that fans could be included in almost all buildings that accommodate, or are often used by, people. The fieldwork was conducted during the hot season, emphasizing the need for cooling opportunities. However, these needs might not be representative of the cooler

---

periods of the year. Additionally, almost none of the buildings currently have fans, and the usage patterns had to be assumed. Therefore, even though the insensitivity of the usage patterns is slightly reduced when the temperatures are lower, it might be overestimated. It should also be noted that the people at the property who are used to the heat might not need the fans as much as the authors have assumed based on their own experiences.

Some fridges are distributed in the buildings as well. As these appliances are assumed to be used throughout the year, they affect the total energy consumption to a large degree. Economic investments would have to be made to include the fridges in the load profiles. It is not known when such investments will be made. Additionally, it is not guaranteed that fridge access will be prioritized in all buildings that are accounted for. The load profiles might therefore account for more fridges than what is realistic. However, all fridges are included based on conversations with the administration of Eco Moyo (Sanner 2022) and people at the property. It is therefore considered to be a reasonable assumption that it will be a priority when the electricity access allows for it.

An overall source of uncertainty is the choices the authors have made based on their assumptions about appliance usage. Because it is difficult to predict how user behavior will adjust with more electricity supply, the assumptions are, to a large degree, based on experiences the author's experiences. In addition, the authors are more familiar with reliable electricity access than the people at Eco Moyo. Hence, the appliance usage predicted in the load profile might not be accurate for people not used to having reliable electricity access.

### **Accounting for seasonal variations**

Seasonal variations were accounted for by dividing the year into seasons based on the temperatures, visitor activity, and school activity. Several moments of uncertainty are related to the method of establishing these seasons.

Kenya is vulnerable to climate change impacts. The increasing average temperatures and the unpredictable weather cause uncertainty related to the annual variations that are accounted for in the load profiles. It might, for instance, not be relevant with a cold season, as all temperatures will be above a certain level. Additionally, the time periods related to the different seasons will likely vary more than what is assumed. However, the only adjustments made to these seasons were the user behavior related to fans and fridges. Therefore, even though these appliances affect the load profiles, it is considered reasonable to assume that the user behavior does not change enough for the system results to be notably changed.

The considerations that accounted for the vacations included the assumption of no activity in several school-related buildings. The activity in the Staff Room, Director's office, and Director's housing was also adjusted. This choice is based on information about the school activity that was obtained during the fieldwork. However, this foundation of knowledge was used to establish consistent user behavior during weekends and vacations. Deviations from this were therefore not accounted for. Hence, the load profiles during vacations do not capture the possibility of other school activities than what was captured in the fieldwork.

It was seen from the resulting load profiles that the energy consumption in the expanded visitor area is highly affected by visitor activity. During periods where the visitor area is assumed only to have three visitors, the load is significantly lower than the rest of the year. Throughout the periods of high visitor activity, the buildings in the expanded visitor area are assumed to house people to their full capacity. Even though it is confirmed by the administration of Eco Moyo (Sanner 2022) that this is a desirable scenario for the given months, it might not be realistic immediately after the visitor area is expanded. The load profiles that are established for the expanded visitor area do therefore not account for when there are more variations in the visitor activity. This results in a load profile with significant contrasts and possibly a wrongly estimated load for the periods with different visitor activity than what is accounted for.

The load profile of the kitchen is adjusted for these periods as well. The biggest difference is that the number of laptops and phones varies with the visitor activity. The peak load almost doubles when there is high visitor activity. However, the differences in power consumption are not

---

significant during most of the day. as can be seen in Figure

### **Time windows**

The time windows that were given as model input to RAMP are based on both interviews, observations during the fieldwork, and the author's assumptions. Even though these sources give an idea of how the user behavior is, more significant deviations are not accounted for. The time windows related to the fans are particularly uncertain, as these had to be based solely on the author's assumptions. Because the people at the school were not used to fans, it was difficult for them to give feedback on how they would use it. As it is assumed that fans will be used during the night, the total electricity usage related to the fans can be more excessive in the load profiles than what is realistic if this assumption is not reasonable.

### **Random variability**

The parameters related to random variability is extracted from the source-file of the RAMP model. However, it would be beneficial to perform a sensitivity analysis to capture the effect of using different values for these parameters. As some appliances could be assumed to have larger deviations in their user habits, especially if they are used by several people, the load profiles might have been more accurate if the random variability was adjusted accordingly.

### **Future expansions**

A high level of uncertainty is related to the load profiles of the future building prospects. Firstly, it is a big assumption that the future buildings are included in the system simulations. Even though the chosen expansions are expected to be built within one or two years, there is a level of uncertainty related to this time frame. Because most of these projects depend on larger investments, the time frame is affected by the timing of such investments. Hence, it might not be realistic to assume that all future expansions are already built when new off-grid systems are installed. However, it is reasonable to conclude that the electricity access at the school should be able to supply these buildings, as they are expected to be a part of the property within the next years.

Secondly, as the future expansions of the property are not yet existing, there was no possibility of observing the user habits related to these buildings. Hence, all appliances, and the user patterns related to these, are assumed based on dialogues with a representative from the administration of Eco Moyo(Sanner 2022). Both the quantity and the user patterns of the appliances might therefore not be representative for when the projects are realized. Additionally, the building plans might be adjusted to fit the budget of the available funding. This would entail that the electricity consumption might be adjusted as well.

The load profile of the whole property emphasizes the possible effects that the assumptions made for the future expansions could have on the results. As these buildings highly affect the aggregated load profile at the property, a wrongly estimated load for these buildings could entail wrongly sized system proposals.

### **User flexibility**

Another aspect that might make the load profiles less accurate is the assumption that there is no user flexibility. For example, many of the load profiles that are presented in Chapter 6 have high load peaks because appliances are used at the same time. These peaks could be reduced by spreading the consumption more throughout the day. This could ensure that smaller system proposals could be sufficient.

It was observed that the teachers had adjusted their user habits to what they had learned that the previous system in the Staff Room could provide. This reflects a willingness for user flexibility. However, the adjustments that people had to make resulted from an insufficient system. As it is desirable to propose solutions that can supply reliant power to the property, it was considered a priority to ensure that it did not require flexibility from the people at the property.

### **Excluding Solar Home Systems**

The current SHSs at the property are not accounted for in the load profile construction. This entails

---

that the system proposals are dimensioned to supply electricity consumption in buildings that are currently supplied by this power source. This could potentially entail that some of the load in these buildings are not necessary to account for. However, because the SHSs only provide electricity to small appliances, it is not considered an influential factor compared to the buildings that use more energy-demanding appliances. Additionally, many of the buildings that are currently supplied by SHSs are assumed to be using fans once they have access to more electricity. Such electricity usage is not possible with only SHSs, and hence the buildings would be limited to continue with smaller appliances if the new system proposals are not able to supply them. It is therefore concluded that it is preferred to include the buildings that currently can be supplied by a SHS.

### **Power ratings**

The power ratings of the appliances used in the load profiles might not be accurate for what is used at the property. It was decided to use nominal power ratings rather than measured for most appliances. This was to remove the possible source of error from incorrect measurements. This could entail a larger load than realistic, as not all appliances are expected to operate at their nominal power rating. However, it is concluded that it is better to ensure that the system can provide the theoretical power ratings to ensure that the system is not undersized.

Additionally, as many of the appliances are not currently at the property, some uncertainty is related to the power ratings of the appliances that are assumed to be used in the future. It is, for instance, decided to use the power ratings of a small, energy-efficient fridge. The proposed systems are therefore not adjusted for fridges with larger power consumption. Hence, they entail some requirements for the appliance purchases that will be made in the future.

### **9.6.2 Utilizing external modelling tools**

There are moments of uncertainty related to using external modeling tools, such as RAMP and PVsyst. All algorithms, specifications, and simplifications that are embedded in these tools can affect the results. This is especially accurate when using default values and configurations, which was done for some of the components in PVsyst. Some of the model input RAMP was also based on values that were obtained from the source code related to this model. However, as RAMP is available as an open-source code, it is possible to get insight in the model configuration.

This is not the case for PVsyst. Without insight into all premises for the tool outputs results, some uncertainty should be accounted for. It is, for instance, known that PVsyst simulations are performed with hourly time steps (PVsyst 2022cI). This entails that an hourly average is calculated for the load profiles, meaning that peak loads that are only present for minutes at the time are not captured. This could possibly entail a smaller system what is needed to supply such peaks.

### **9.6.3 System topology**

The system topologies presented are simplified and might not represent what will be installed at the property. Firstly, the choice between using an AC- and DC microgrid were highly affected by observations made during the fieldwork. With several advantages, such as reduced power losses due to possibly fewer conversion steps, DC microgrids could be a theoretically favorable option. However, the fieldwork demonstrated the difference between what is a theoretically attractive solution and what is realistic. Local expertise could inform that it was not a standard solution locally. The choice of using an AC microgrid was therefore highly affected by the preferences of the local company. However, it is difficult to foresee whether the development toward more use of DC microgrids and DC appliances will happen more rapidly than assumed based on the fieldwork. If the market becomes more mature for both, the advantages related to DC microgrids could make this a preferred solution. In that case, the inverter might not be necessary (given that only DC loads are supplied).

Secondly, using an AC-coupled system is also based on the possibility that the school will be connected to the utility grid or that diesel generators will be used as a backup. However, it is

---

initially not a desirable scenario for Eco Moyo to use these backup solutions. Hence, it might have been unnecessary to include these solutions in the decision-making of the system topology.

It should be noted, however, that PVsyst only accounts for the DC/DC conversion in the MPPT controller. Hence, the simulation results would have been the same, independent of this choice. Additionally, the fieldwork resulted in the important observation that all load at the property is AC. It does not seem to be realistic with development to DC appliances either. Hence, an inverter would be needed to supply the AC load observed at the property either way.

Another source of uncertainty regarding the system topology is the choice of separating the MPPT controller and the inverter, meaning that a DC bus is needed to ensure that the charging of the battery is regulated. However, during the fieldwork, a hybrid solar inverter was used. This choice entailed that a DC bus is unnecessary because the battery is charged directly by the solar inverter. Hence, if this same choice is made for new systems, it would entail that the system topology would look different. However, this change would not be accounted for in the PVsyst simulations either, and the simulation results would be the same. The main difference in the results would be therefore, the investment costs.

#### 9.6.4 Additional losses

As the PVsyst simulations do not account for other conversion steps than the MPPT-controller, more losses than what is presented in the simulation results should be expected. Furthermore, if DC appliances will be used at the property in the future as well, additional losses should be accounted for as a conversion between the AC system and the DC load would have to be accounted for as well. Given these simplifications, the system performance can be assumed to entail worse performance due to power losses than what is presented.

The same can be said for transmission losses. It could, for instance, be beneficial to evaluate whether the choice of supplying buildings through cables is beneficial if they have a low power consumption. There are, for instance, long distances between the system in the kitchen and the security building. The same can be said for many of the classrooms and the system that is expected to supply them. These buildings are not necessarily dependent on more electricity than what small SHSs can provide. Hence, the transmission losses and costs of using cabling to supply these buildings could, for instance, be compared to the costs of installing SHSs on the buildings instead. It should also be evaluated whether electricity access should be prioritized in these buildings if the transmission losses, or the costs, are high. This is especially accurate for the classrooms with architecture that allows for good ventilation and lighting. However, such calculations were not a part of the research scope of this master thesis.

#### 9.6.5 Component selection

An important source of uncertainty is the possible difference in the components used in the PVsyst simulations and the components that will be installed at the property. This is especially true for rural areas, where the availability of certain components varies. However, this uncertainty is significantly decreased due to fieldwork at the site and collaboration with Chloride Exide to perform future installations. This is because data about what components are available at the site, which components Chloride Exide assumes to be used for further installations, and the prices for these components have been confirmed through conversations and observations. Despite these confirmations, moments of uncertainty are related to the components that are used in the simulations. These will be discussed in the following chapters.

#### PV panels

As for the PV panels, there is not a lot of uncertainty related to them. The capacity of 450 W<sub>p</sub> for the panels is not assumed to be changed, as this was recommended by Chloride Exide. However, unforeseen factors such as stock availability and changes in manufacturers used could affect the chosen capacity and the price. This is however assumed to make a small difference.

In relation to installation of PV panels at buildings that do not currently exist, i.e. in the visitor area, the Computer Lab, and the multi-area building, an azimuth and plane tilt is set to respectively  $0^\circ$  and  $10^\circ$ . This is due to recommendations from Chapter 3.2.4, and as this will be given as recommendation for new buildings to the management at the school, it is assumed that this will be used. However, a small sensitivity analysis is performed to explore the impact this constitutes. This is performed in PVsyst by looking at the annual meteo yield, by looking at the parameters Transposition Factor (FT) and loss with respect to optimum. FT is defined as “the ratio of the incident irradiation on the plane to the horizontal irradiation” (PVsyst 2022h). Hence, it is a parameter that says how much that is gained or lost when tilting the plane. Figure 85 shows the graphs for performance yield for the system with regards to the plane tilt and azimuth, respectively to the left and right.

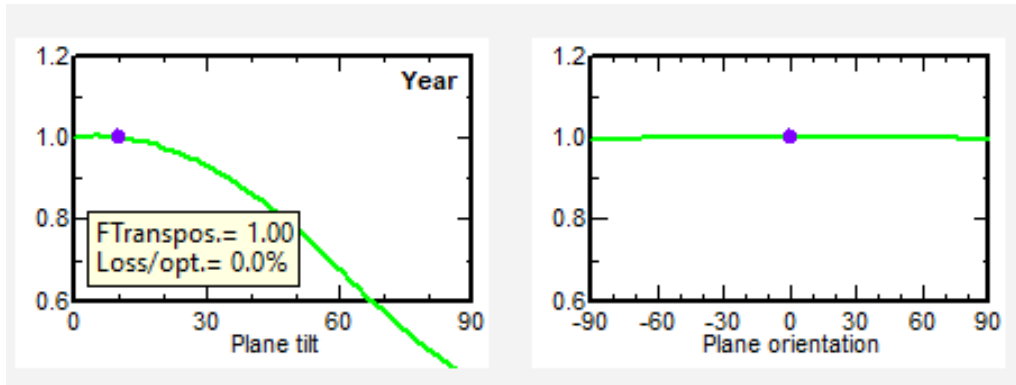

Figure 85: Sensitivity analysis of optimal azimuth and plane tilt.

From the left graph, regarding plane tilt, it is clear that the plane tilt has an impact on the performance. Table 46 shows the results of a sensitivity analysis performed with a fixed azimuth of  $0^\circ$  and where the plane tilt is the sensitivity parameter.

Table 46: Sensitivity analysis plane tilt.

Tilt	FT [-]	Loss [%]	Irradiation [kWh/m <sup>2</sup> ]
$0^\circ$	1.00	0.0	2,008
$5^\circ$	1.00	0.0	2,013
$10^\circ$	1.00	0.0	2,007
$15^\circ$	0.99	-0.9	1,989
$20^\circ$	0.98	-2.4	1,959

The table shows that the loss is not significant until the plane tilt is more than  $15^\circ$ . Hence, as long as the PV panels are not installed at roof with an angle exceeding  $15^\circ$ , the results are assumed to be valid.

In the right graph in the Figure 85 it can be seen that the azimuth’s impact on the performance is negligible. This is confirmed in Table 47, where it is seen that by turning the PV panel the opposite way of the optimal, i.e. towards south at  $\pm 180^\circ$ , the loss with respect to the optimum is only -0.8 %. Hence, it is assumed that the performance will not be significantly affected if they are put in a different azimuth. However, the recommendation will still be to strive to put the panels towards north at an azimuth of  $0^\circ$ .



---

Table 47: Sensitivity analysis of optimal azimuth.

<b>Azimuth</b>	<b>FT</b> [-]	<b>Loss</b> [%]	<b>Irradiation</b> [kWh/m <sup>2</sup> ]
0°	1.00	0.0	2,007
+/- 90°	1.00	-0.4	2,000
+/- 180°	0.99	-0.8	1,991

### Converters and controllers

A source of uncertainty in relation to the component selection is the controllers. In the PVsyst simulations a universal controller is used, as explained in Chapter 7.4.2. All default values remained unchanged as well. This gives a big insecurity in relation to the costs and performance of the controller, as it might not be representative for an inverter that Chloride Exide would prefer to use. The choice of using an MPPT controller is based on the desire to maximize the PV production, and hence the system's ability to supply the load. Even though this is desirable for the system that will be installed, this component is more expensive than if the PV panels were connected through regular converters. As the system would be able to operate without an MPPT controller, this is a component that might not be prioritized if the budget is strictly limited. Hence, the simulation results might not be representative for what it would be if the system did not include the MPPT controller. However, an MPPT controller was included in the system that was installed during the fieldwork even though the budget was limited.

### Batteries

As for the batteries, the recommended solutions for the new systems include lithium-ion batteries. Because the data sheets of the lithium-ion batteries that Chloride Exide can provide are unknown, default values were used in the simulations with these battery types. This could entail that the system simulations might not reflect the actual system that will be installed. Additionally, Chloride Exide has previously decided to use lead-acid batteries at the property. It is therefore a possibility that they will continue to do this even though the recommendation is lithium-ion batteries. This would entail different system performance and costs as well.

When performing simulations for the existing system at the property, the SoC of the lead-acid batteries were set to 50 %. This is based on recommended values to not shorten battery lifetimes. However, this value might not reflect the SoC that is accurate for the current system at the property. However, when determining the values that are used in the system simulations, it was important to not over-estimate the capacity of the current system. If the SoC is set unrealistically low, the simulations might result in better system performance than what is representative for the system. It is therefore decided that the value that is used is reasonable as it represents an upper boundary, as it is not likely that the batteries at the property have a lower SoC. However, it might entail a smaller, or different, battery capacity than what is currently available at the installed system. The SoC of the lithium-ion battery is kept at the default value that PVsyst proposes, i.e. 10 %.

### 9.6.6 Component prices

As it is difficult to obtain realistic prices that reflect the Kenyan market, several assumptions regarding the component prices were made. These assumptions might not reflect the accurate prices for the system. The uncertainty related to these should therefore be considered.

### PV panels

The prices of the PV panels were obtained by finding a common price per  $W_p$ . These were calculated from PV panel prices on the Chloride Exide website. Even though the prices on these websites are known to represent a price indication, it is experienced that other components than what is presented on the websites are used in the actual installations. Hence, the prices might not be an accurate representation. Additionally, a high level of uncertainty is related to the assumption that there is a common price per  $W_p$ .

---

## Batteries

To obtain the battery prices, the ratio between lead-acid and lithium-batteries from a Norwegian supplier was calculated. It was therefore assumed that this ratio is the same for Kenyan suppliers. Because the price of a lead-acid battery was known from the fieldwork, this price was the foundation for the calculated price of the lithium-ion batteries. However, the price difference between lead-acid batteries and lithium-ion batteries might be different in Kenya. Additionally, the brand for the lead-acid battery might not be representative for what would be used for the lithium-ion battery. Hence, even if the ratio is accurate, the prices might be wrong due to differences in the brands or suppliers that are used.

## Converters and controllers

The prices that were used for the controllers and converters in the results, given in NOK per  $W_p$ , entail uncertainties as well. Even though this price is representative for the components that were proposed by Chloride Exide, it might not necessarily be transferable the components that actually will be used. Additionally, the capacities of a component is pre-defined by the supplier. Increasing the size of the component would therefore possibly entail using a capacity that is larger than exactly what is needed, as the size intervals can be large. Hence, the method of using a marginal cost of on the controllers directly on its calculated size is not representable for what the cost would be in reality. As a result, the prices that are calculated for the converters and controllers can therefore be underestimated.

### 9.6.7 Weather data

The following chapter is directly extracted from the preliminary project (K. T. Lervik and Waitz 2021, p.70).

A factor that might affect the performance of the system is the choice of weather resources. As presented in Chapter 7.4.1, Meteonorm provides weather data collected between 1991 and 2010. Even though this weather source was chosen because it had more recent data than NASA SSE, it does not capture the effects of climate change from the last 11 years. Climate change in Kenya entails uncertainties of rainfalls, droughts, and increased temperatures. These phenomena can affect the system performance significantly. It is therefore expected that the installed system will perform worse than what is reflected in the simulation results.

### 9.6.8 Grid connection

For the evaluation of the grid connection, only two scenarios were considered. These scenarios were two “extreme points”; one with almost no PV generation and self storage, and one with almost sufficient PV generation and self storage. These scenarios gave that grid connection was found to be infeasible. A solution in between these two extreme points could give a more viable result. However, the point of including grid connection was mainly to have a reference point to compare the off-grid solutions with, and therefore it was not found necessary to evaluate any more scenarios.

The Covid-19 pandemic and the war in Ukraine have caused an unstable world situation in the recent years, currently, and possible also for years to come. This has had a impact on the prices for both electricity and diesel, which have increased significantly. Therefore there is a great uncertainty related to these values, and it is almost impossible to predict these costs.

The possibility of injecting power to the utility grid in the future in Kenya also stands out as a uncertainty. It is not known if this will be possible at all, and what the prices will be if made possible. However, the feed-in tariff did not have a significant impact on the results, and therefore it is concluded that the uncertainty related to the set feed-in tariff is not highly relevant. It would make a difference if the feed-in tariff was much higher giving that the school could make a significant revenue from sale of excess energy, but this is highly unlikely.

---

The main source of uncertainty for the grid connection evaluations is the investment cost. This is due to that the obtained data for investment costs ranges from approximately 1,500 NOK to 200,000 NOK. A high value in relation to this range was chosen as the numbers were given after a formal offer from the corporation REREC. It is however important to note that if the real grid connection cost is in the lower range, it could be a viable option.

For the scenario with the current PV system, this would include a very low investment cost. Then the only cost would be the operation costs of approximately 14,000 NOK per year. This gives that it would take around 20 years to “break-even” with the investment cost for the cheapest off-grid solution, i.e. non-clustered with 2.0 days of autonomy. This would, however, entail around 24,000 additional kg CO<sub>2</sub> to the atmosphere through the 20 years and is still not considered a good option. However, this illustrates the impact the uncertainty the grid connection cost possibly can have.

The same goes for the scenario with an extended PV system with almost sufficient PV generation and battery storage. If the grid connection cost is almost negligible, it will allow for the school to produce most of the electricity needed to cover its electricity demand, but to utilize a grid connection when the off-grid solutions are insufficient. If it becomes possible to inject power to the grid, and the grid connection cost is not higher than the potential revenue from selling excess energy, found to be 5000 NOK per year, this slight improvement in performance, i.e., 0 % unmet demand, could be justified cost-wise. The CO<sub>2</sub> emissions related to this solution is also low, 10 kg/year or 0.01 tCO<sub>2</sub>/year.

It should also be noted that the calculated supplied energy by the utility grid entails the assumption that the grid can provide reliable and sufficient energy supply whenever it is needed. However, this assumption does not account for the recent black-outs and unreliability that is associated with the local utility grid. Hence, the system performance in terms of supplied energy is expected to be much lower than what was found in the calculations.

### 9.6.9 Backup generator

A source of uncertainty for the backup simulations in PVsyst is the chosen nominal powers for the diesel generators, as only the three nominal powers found in the PVsyst components database were explored. Therefore a more optimal nominal power could be chosen. However, it is found that the sizes are in the correct range even though not optimized.

For the price of the diesel generators, Norwegian prices were used as they were found to be in the same range as the assumed prices from Chloride Exide. There is, therefore, an uncertainty connected to the investment costs of the diesel generator solutions, as the actual costs of the diesel generators in Kenya are not known.

As for the electricity price in the grid connection evaluations, there are some significant uncertainties related to the fuel prices and hence the operating costs due to the unstable situations due to the Covid-19 pandemic and war in Ukraine. Therefore there is a great uncertainty related to these values, and it is almost impossible to predict how much higher the prices will go, if they will stagnate, or if they will be reduced in the near future and next few years.

Conclusively, it is found that the simplifications made concerning the backup simulations with diesel generators are acceptable. This is because the simulations and evaluations were performed to find the approximate magnitudes of impacts and not the exact values.

---

## 10 Conclusion

The research question of this master thesis was defined as:

*What is the optimized system solution for a microgrid to supply the electricity demand at Eco Moyo Education Centre?*

Such an optimized system was defined within project-specific boundaries, and the premise was defined as a cost-effective and reliable system solution. In the establishment of the boundaries of the optimized system, the preliminary project conducted in the fall 2021 by the authors, fieldwork conducted in march 2022 at the site, and preferences defined by Eco Moyo were essential.

A boundary set based on the preliminary results was that the electricity production should be based on PV technology. It also determined the simulation tools used for the load profile establishments and system solution simulations, respectively RAMP and PVsyst. Data collected during fieldwork through measurements, conversations, and interviews set further boundaries for the project and established the foundation for the input to load profiles and system simulations. Further, the preferences defined by Eco Moyo were to keep the school self-sufficient and supplied with renewable energy. A desire to continue the use of clusters at the property and that these are self-sufficient was also defined. It was also essential to ensure that the system proposals could supply future developments at the property. Expected buildings were, therefore, accounted for as well. Finally, the cooperation with a local company for installations also set boundaries for the project regarding available competence, preferences, and components.

The bottom-up stochastic model generation that RAMP provides was used to establish minute-based annual load profiles for the school. This choice was based on the high performance of this modeling tool and the inaccuracy related to user surveys and interviews. Model input accounted for the electricity demand in both current and expected buildings at the property. Seasonal and weekly variations were accounted for as well.

Based on preferences defined by Eco Moyo of a cluster-based approach, it was decided to evaluate system solutions with separate systems for each cluster, referred to as a clustered solution. Six clusters were therefore established. The clustered solution was compared with a system solution where the whole property was supplied by one system, referred to as a non-clustered solution. Hence, load profiles were constructed for all clusters, as well as the non-clustered solution. For the non-clustered solution, two separate solutions were defined, with 2.0 days and 2.7 days of autonomy.

The proposed system topology was an AC-coupled microgrid supplied by PV panels and lithium-ion batteries. The load profiles were used as input to the off-grid PVsyst simulations. The desire to provide self-sufficient clusters was the basis of using off-grid system solutions as the main evaluation. System solutions for each cluster and non-clustered solutions were proposed based on the simulation results in PVsyst. Investment costs, autonomy, and electricity demand coverage were considered important parameters when determining these system solutions. For comparative purposes, backup solution evaluations with diesel generators and grid connection were also performed.

It was found that the non-clustered solution with 2.7 days of autonomy gives the highest system solution performance and the highest investment cost at 383,000 NOK. The non-clustered solution with 2.0 days of autonomy gives a slightly lower system performance but the cheapest investment cost at 298,000 NOK. Finally, the clustered solution has the lowest yet sufficient system performance with a total investment cost of 335,000 NOK.

In general, it was found that the system performances were high and similar for all three system solutions, and other considerations had to be accounted for in order to conclude what the optimized system solution for the school is. The main difference between the clustered and non-clustered solutions is that the clustered solution allows for gradual expansions of the system at the property. This is a significant advantage, as it fits well with the financial structure at Eco Moyo, which includes sporadic funding of different magnitudes. Thus a clustered solution allows for gradual expansions when funding is available and when Eco Moyo finds the need. The electricity demand on the property is also highly dependent on the new building projects, and there is, therefore, uncer-

tainty connected to the placements and electricity demand of these buildings and the established load profiles. A clustered solution allows for a correction of load profiles and system solutions if any project boundaries change in the future. The clustered solution also allows the current functioning systems at the property to be utilized while it is still functioning. The non-clustered solution does not allow for such gradual expansions, and the system can be incorrectly dimensioned if the project boundaries as assumed in the master thesis change.

For the backup evaluation, it was found that grid connection with the current PV system at the property offers the cheapest option for the school in terms of investment costs. However, an off-grid solution provides a better environmental profile and is therefore in line with Eco Moyo's preferences. A combination of an expanded PV system and grid connection resulted in an unjustifiable solution due to the significant investment costs. It was therefore found that grid connection does not pose a viable option for Eco Moyo. This decision is further substantiated by the unreliability related to the local utility grid.

For diesel generators, it was found that a cheaper and more environmentally friendly option to get the unmet demand down to 0 % is to install additional PV panels instead of investing in diesel generators. However, this does not provide any backup security if periods with low irradiation or malfunctioning systems entail that the system can not cover the load.

Conclusively, the optimized system solution for Eco Moyo Education Centre is a clustered off-grid solution with 6 distinct clusters with components and investment costs as presented in Table 48. The suggested PV panel placements for each cluster are on the kitchen, director's house, visitors hangout area, class 5, the computer lab, and multi-purpose area, as illustrated in Figure 86.

Table 48: Final system proposal.

Parameter		1	2	3	4	5	6	Total
Batteries	[qty.]	4	8	12	4	8	1	37
Battery area	[m <sup>2</sup> ]	0.35	0.70	1.05	0.35	0.70	0.09	3.24
PV panels	[qty.]	3	5	12	0	6	1	27
PV panel area	[m <sup>2</sup> ]	7	11	27	0	13	2	60
Investment cost	[kNOK]	40	70	118	10	85	12	335



Figure 86: Illustration of final system solution proposal.

Source: J. Lervik 2022.

---

## 11 Further work

This work has contributed to a foundational system proposal for the optimized microgrid at Eco Moyo. However, simplifications are made to obtain these results. Hence, further work should investigate these simplifications further. Some aspects that could be accounted for in future work can be summarized as below:

- *User flexibility*: The possibility of consumers to adjust their usage patterns to the systems to increase reliability and performance should be considered. This is especially important for the clusters with large variations in their electricity usage. If the largest peak loads are evened out, this might reduce the required system size as well.
- *Interconnections between clusters*: As the system results presents high values of excess energy, the possibility of connecting the clusters should be evaluated. The possibility for clusters supplying each other is relevant if the periods of high excess energy of one cluster is simultaneous to a period where there is unmet load in another cluster.
- *Control strategies*: To ensure optimized and safe system performance, control strategies should be evaluated.
- *Detailed system topology*: A detailed system topology, including interconnection between components, wiring, and safety, should be evaluated further. Losses and costs related to cabling and additional components should be evaluated as well.
- *Possibility of hybrid systems*: If DC appliances become more common at Eco Moyo, the possibilities of expanding the system topology to be a hybrid microgrid with a DC distribution to supply the DC load directly should be evaluated.
- *Advanced economic and performance evaluations*: Additional attention could be paid to economic parameters such as the Net Present Cost (NPC) and LCOE to evaluate the system's long-term performance in terms of financial aspects. This is especially relevant if other system components are to be re-evaluated.

---

## Bibliography

- Adwek, George et al. (2020). ‘The Solar Energy Access in Kenya: A Review Focusing on Pay-As-You-Go Solar Home System’. In: *Environ Dev Sustain* 22, pp. 3897–3938. DOI: <https://doi.org/10.1007/s10668-019-00372-x>.
- Aemro, Yohannes Biru, Pedro Moura and Anibal T. de Almeida (2020). ‘Design and Modeling of a Standalone DC-Microgrid for Off-Grid Schools in Rural Areas of Developing Countries’. In: *Energies*. DOI: <https://doi.org/10.3390/en13236379>.
- Alfergani, Asma et al. (2018). ‘Control strategies in AC microgrid: A brief review’. In: *2018 9th International Renewable Energy Congress (IREC)*, pp. 1–6. DOI: 10.1109/IREC.2018.8362575.
- Alireza Khaligh, Omer C. Onar (2018). *Power Electronics Handbook (Fourth Edition)*. Butterworth-Heinemann. DOI: <https://doi.org/10.1016/B978-0-12-811407-0.00025-8>.
- AlternativeEnergyTutorials (2022). *Series Connected Solar Panels*. URL: <https://www.alternative-energy-tutorials.com/solar-power/series-connected-solar-panels.html>. (visited on 13th June 2022).
- Anand, Sandeep and B. G. Fernandes (2010). ‘Optimal Voltage Level for DC Microgrids’. In: *IECON 2010 - 36th Annual Conference on IEEE Industrial Electronics Society*, pp. 3034–3039. DOI: 10.1109/IECON.2010.5674947.
- Andreu, Jon et al. (2014). ‘AC and DC Technology in Microgrids: A Review’. In: *Elsevier*. DOI: <https://doi.org/10.1016/j.rser.2014.11.067>.
- Blodgett, Courtney et al. (2017). ‘Accuracy of Energy-Use Surveys in Predicting Rural Mini-Grid User Consumption’. In: *Energy for Sustainable Development* 41, pp. 88–105. ISSN: 0973-0826. DOI: <https://doi.org/10.1016/j.esd.2017.08.002>.
- Bygg, Obs (2022a). *Probuilder inverter aggregat 3000W*. URL: <https://www.obsbygg.no/verktoy-og-tilbehor/elektroverktoy/sager/aggregater/2264249?v=ObsBygg-5709386627614> (visited on 6th June 2022).
- (2022b). *Probuilder inverter aggregat 5500W*. URL: <https://www.obsbygg.no/verktoy-og-tilbehor/elektroverktoy/sager/aggregater/2251804>? (visited on 15th May 2022).
- ChlorideExide (2022a). *About Us - Chloride Exide Limited*. URL: <https://www.chlorideexide.com/about-us/> (visited on 24th May 2022).
- (2022b). *Solar Ritar 200AH 12V Power Deep Cycle Maintenance Free Battery*. URL: <https://www.chlorideexide.com/product/solar-200ah-12v-ritar-power/> (visited on 15th May 2022).
- Diouf, Boucar and Ramchandra Pode (2015). ‘Potential of Lithium-ion Batteries in Renewable Energy’. In: *Renewable Energy* 76, pp. 375–380. ISSN: 0960-1481. DOI: <https://doi.org/10.1016/j.renene.2014.11.058>.
- DNV (2021). ‘Energy Transition Outlook 2021: Sub-Saharan Africa Regional Forecast’. In: EcoMoyo (2022a). *Eco Moyo*. URL: <https://www.ecomoyo.com/> (visited on 23rd May 2022).
- (2022b). *Eco Moyo Students*. URL: <https://www.ecomoyo.com/students> (visited on 23rd May 2022).
- (2022c). *The Area Eco Moyo*. URL: <https://www.ecomoyo.com/our-area> (visited on 23rd May 2022).
- Ekici, Sami and Mehmet Ali Kopru (2017). ‘Investigation of PV System Cable Losses’. In: *International Journal of Renewable Nergy Research - IJRER* 7. URL: [https://www.researchgate.net/publication/317701311\\_Investigation\\_of\\_PV\\_System\\_Cable\\_Losses](https://www.researchgate.net/publication/317701311_Investigation_of_PV_System_Cable_Losses).
- EWB (2022). *About EWB*. URL: <https://iug.no/about-us/?lang=en> (visited on 23rd May 2022).
- EWB, EcoMoyo and AUG (2020). ‘Eco Moyo Strategisk Plan’. In: URL: [https://issuu.com/ecomoyokenya/docs/ecomoyo\\_strategisk\\_plan\\_200305](https://issuu.com/ecomoyokenya/docs/ecomoyo_strategisk_plan_200305).
- Ezinwanne, Osisioma, Fu Zhongwen and Li Zhijun (2017). ‘Energy Performance and Cost Comparison of MPPT Techniques for Photovoltaics and other Applications’. In: *Energy Procedia* 107. 3rd International Conference on Energy and Environment Research, ICEER 2016, 7-11 September 2016, Barcelona, Spain, pp. 297–303. ISSN: 1876-6102. DOI: <https://doi.org/10.1016/j.egypro.2016.12.156>.
- FXEmpire (2022). *Kenya Gasoline Prices 1990-2021*. URL: <https://www.fxempire.com/macro/kenya/gasoline-prices> (visited on 15th May 2022).
- Generatorist (2022). *Power Consumption of Household Appliances*. URL: <https://generatorist.com/power-consumption-of-household-appliances> (visited on 13th June 2022).

- 
- Hansen, John Michael and George A. Xydis (2020). ‘Rural electrification in Kenya: a Useful Case for Remote Areas in Sub-Saharan Africa’. In: *Energy Efficiency* 13, pp. 257–272. DOI: <https://doi.org/10.1007/s12053-018-9756-z>.
- Hartvigsson, Elias and Erik O. Ahlgren (2018). ‘Comparison of Load Profiles in a Mini-Grid: Assessment of Performance Metrics using Measured and Interview-based Data’. In: *Energy for Sustainable Development* 43, pp. 186–195. ISSN: 0973-0826. DOI: <https://doi.org/10.1016/j.esd.2018.01.009>.
- Hartvigsson, Elias, Jimmy Ehnberg et al. (2015). ‘Assessment of Load Profiles in Minigrids: A Case in Tanzania’. In: *IEEE*. URL: <https://ieeexplore.ieee.org/stamp/stamp.jsp?tp=&arnumber=7339818>.
- Hlal, Mohamad Izdin et al. (2019). ‘Optimum Battery Depth of Discharge for Off-grid Solar PV/Battery System’. In: *Journal of Energy Storage* 26, p. 100999. ISSN: 2352-152X. DOI: <https://doi.org/10.1016/j.est.2019.100999>.
- Hofstad, Knut (2022). *Solenergi - Store Norske Leksikon*. URL: <https://snl.no/solenergi> (visited on 20th May 2022).
- Hosseinalizadeh, Ramin et al. (2016). ‘Economic Sizing of a Hybrid (PV–WT–FC) Renewable Energy System (HRES) for Stand-Alone Usages by an Optimization-Simulation Model: Case study of Iran’. In: *Renewable and Sustainable Energy Reviews* 54, pp. 139–150. ISSN: 1364-0321. DOI: <https://doi.org/10.1016/j.rser.2015.09.046>.
- IEA (2020). *Solar - Fuels and Technologies*. URL: <https://www.iea.org/fuels-and-technologies/solar> (visited on 20th May 2022).
- (2022a). *2010 Electricity Rules (Feed-in Tariff)*. URL: <https://www.iea.org/policies/4962-2010-electricity-rules-feed-in-tariff?> (visited on 19th May 2022).
- (2022b). *IEA Kenya*. URL: <https://www.iea.org/countries/kenya> (visited on 24th May 2022).
- IPA (2022). *Kenya Rural Electrification Authority*. URL: <https://www.poverty-action.org/organization/kenya-rural-electrification-authority> (visited on 6th June 2022).
- IRENA (2016). ‘Innovation Outlook; Renewable Mini-Grids’. In: *International Renewable Energy Agency*. URL: [https://www.irena.org/-/media/Files/IRENA/Agency/Publication/2016/IRENA\\_Innovation\\_Outlook\\_Minigrids\\_2016.pdf](https://www.irena.org/-/media/Files/IRENA/Agency/Publication/2016/IRENA_Innovation_Outlook_Minigrids_2016.pdf).
- (2019). ‘Renewable Mini-Grids, Innovation Landscape Brief’. In: *International Renewable Energy Agency*. URL: [https://www.irena.org/-/media/Files/IRENA/Agency/Publication/2019/Sep/IRENA\\_Renewable\\_mini-grids\\_2019.pdf](https://www.irena.org/-/media/Files/IRENA/Agency/Publication/2019/Sep/IRENA_Renewable_mini-grids_2019.pdf).
- KenGen (2022). *KenGen - Who We Are*. URL: <https://www.kengen.co.ke/index.php/our-company/who-we-are.html> (visited on 24th May 2022).
- KPC (2022). *Kenya Power - Who We Are*. URL: <https://kplc.co.ke/content/item/14/about-kenya-power> (visited on 24th May 2022).
- Kularatna, Nihal (2015). *Energy Storage Devices for Electronic Systems*. Academic Press. ISBN: 978-0-12-407947-2. DOI: <https://doi.org/10.1016/C2012-0-06356-9>.
- Kurzweil, Peter (2015). ‘Lithium Battery Energy Storage: State of the Art Including Lithium–Air and Lithium–Sulfur Systems’. In: *Electrochemical Energy Storage for Renewable Sources and Grid Balancing*. Ed. by Patrick T. Moseley and Jürgen Garche. Amsterdam: Elsevier, pp. 269–307. ISBN: 978-0-444-62616-5. DOI: <https://doi.org/10.1016/B978-0-444-62616-5.00016-4>.
- Laconde, Thibault (2022). *Kenya: Innovation at the Service of Low-Carbon Electrification*. URL: [https://www.climate-chance.org/wp-content/uploads/2019/02/en\\_fp1-electricite-kenya\\_def-1.pdf](https://www.climate-chance.org/wp-content/uploads/2019/02/en_fp1-electricite-kenya_def-1.pdf) (visited on 15th May 2022).
- Lervik, Johannes (2022). Private Communication. Trondheim, Norway.
- Lervik, Kari Thorset and Anja Myhre Waitz (2021). ‘Development of a Microgrid at the Eco Moyo Primary School in Kenya’. In: *Energy for Sustainable Development* 43, pp. 186–195. ISSN: 0973-0826. DOI: <https://doi.org/10.1016/j.esd.2018.01.009>.
- Logic, Daft (2022). *List of the Power Consumption of Typical Household Appliances*. URL: <https://www.daftlogic.com/information-appliance-power-consumption.htm> (visited on 13th June 2022).
- Lombardi, Francesco et al. (2019). ‘Generating High-Resolution Multi-Energy Load Profiles for Remote Areas with an Open-Source Stochastic Model’. In: *Energy* 177, pp. 433–444. DOI: <https://doi.org/10.1016/j.energy.2019.04.097>.
- (2022). *An Open-Source Bottom-Up Stochastic Model for Generating Multi-Energy Load Profiles*. URL: <https://github.com/SESAM-Polimi/RAMP> (visited on 30th Apr. 2022).
- Lotfi, Hossein and Amin Khodaei (2017). ‘AC Versus DC Microgrid Planning’. In: *IEEE Transactions on Smart Grid* 8.1, pp. 296–304. DOI: [10.1109/TSG.2015.2457910](https://doi.org/10.1109/TSG.2015.2457910).
-



- 
- Louie, Henry (2018). *Off-Grid Electrical Systems in Developing Countries*. Springer International Publishing AG. DOI: <https://doi.org/10.1007/978-3-319-91890-7>.
- Lumby, Ben (2015). *Utility-Scale Solar Photovoltaic Power Plants - A Project Developer's Guide*. IFC. URL: [https://www.ifc.org/wps/wcm/connect/topics\\_ext\\_content/ifc\\_external\\_corporate\\_site/sustainability-at-ifc/publications/publications\\_utility-scale+solar+photovoltaic+power+plants](https://www.ifc.org/wps/wcm/connect/topics_ext_content/ifc_external_corporate_site/sustainability-at-ifc/publications/publications_utility-scale+solar+photovoltaic+power+plants).
- Mahachi, Tafara and Arnold Rix (Jan. 2017). 'Comparison of Various Long Term Averaged Meteorological Data Sources for a Site in South Africa'. In: URL: [https://www.researchgate.net/publication/313249254\\_comparison\\_of\\_various\\_long\\_term\\_averaged\\_meteorological\\_data\\_sources\\_for\\_a\\_site\\_in\\_south\\_africa](https://www.researchgate.net/publication/313249254_comparison_of_various_long_term_averaged_meteorological_data_sources_for_a_site_in_south_africa).
- Mandelli, Stefano, Marco Merlo and Emanuela Colombo (2016). 'Novel Procedure to Formulate Load Profiles for Off-Grid Rural Areas'. In: *Energy for Sustainable Development* 31, pp. 130–142. ISSN: 0973-0826. DOI: <https://doi.org/10.1016/j.esd.2016.01.005>.
- Masters, Gilbert M. (2013). *Renewable and Efficient Electric Power Systems*. John Wiley and Sons, Inc.
- Merlet, Stanislas (2021). *Personal Communication*.
- Morshed, Md. Sifat et al. (2015). 'Designing of a 2kW Stand-Alone PV System in Bangladesh using PVsyst, Homer and SolarMAT'. In: *2015 3rd International Conference on Green Energy and Technology (ICGET)*, pp. 1–6. DOI: 10.1109/ICGET.2015.7315090.
- Motjoadi, Vinny, Pitshoud N.Boroko and Moses O. Onibonoje (2020). 'A Review of Microgrid-Based Approach to Rural Electrification in South Africa: Architecture and Policy Framework'. In: *Energies*. DOI: <https://doi.org/10.3390/en13092193>.
- Narayan, Nishant, Zian Qin et al. (2020). 'Stochastic Load Profile Construction for the Multi-Tier Framework for Household Electricity Access using Off-Grid DC Appliances'. In: *Energy Efficiency* 13, pp. 197–2015. DOI: <https://doi.org/10.1007/s12053-018-9725-6>.
- Narayan, Nishant, Victor Vega-Garita et al. (2018). 'A Modeling Methodology to Evaluate the Impact of Temperature on Solar Home Systems for Rural Electrification'. In: *2018 IEEE International Energy Conference (ENERGYCON)*, pp. 1–6. DOI: 10.1109/ENERGYCON.2018.8398756.
- NRCAN (2022). *Learn the Facts: Emissions from Your Vehicle*. URL: [https://www.nrcan.gc.ca/sites/nrcan/files/oeef/pdf/transportation/fuel-efficient-technologies/autosmart\\_factsheet\\_9\\_e.pdf?](https://www.nrcan.gc.ca/sites/nrcan/files/oeef/pdf/transportation/fuel-efficient-technologies/autosmart_factsheet_9_e.pdf?) (visited on 15th May 2022).
- Oloya, Ivan T., Tar JL. Gutu and Muiyiwa S. Adaramola (2021). 'Techno-Economic Assessment of 10 MW Centralised Grid-Tied Solar Photovoltaic System in Uganda'. In: *Case Studies in Thermal Engineering* 25. DOI: <https://doi.org/10.1016/j.csite.2021.100928>.
- Opiyo, Nicholas Nixon (2019). 'A cMparison of DC- versus AC-based Minigrids for Cost-Effective Electrification of Rural Developing Communities'. In: *Energy Reports* 5, pp. 398–408. ISSN: 2352-4847. DOI: <https://doi.org/10.1016/j.egyr.2019.04.001>.
- Paul Ayeng'o, Sarah et al. (2018). 'Comparison of Off-Grid Power Supply Systems Using Lead-Acid and Lithium-ion Batteries'. In: *Solar Energy* 162, pp. 140–152. ISSN: 0038-092X. DOI: <https://doi.org/10.1016/j.solener.2017.12.049>.
- POWER (2022a). *Feel Quest Bluetooth Høyttaler Svart*. URL: <https://www.power.no/tv-og-lyd/traadloese-hoeyttalere/bluetooth-hoeyttaler/feel-quest-bluetooth-hoeyttaler-svart/p-1141070/store/> (visited on 13th June 2022).
- (2022b). *Harman Kardon Citation 200 Svart*. URL: <https://www.power.no/tv-og-lyd/traadloese-hoeyttalere/smarthoeyttaler/harman-kardon-citation-200-svart/p-1114211/> (visited on 13th June 2022).
- Powerblox (2022). *Easy and Affordable Access to Clean Energy*. URL: <https://power-blox.com/products> (visited on 28th May 2022).
- Primer, Energy (2022). *Levelized Cost of Energy/Electricity (LCOE)*. URL: <https://mitt.uib.no/courses/4050/pages/5-dot-3-levelized-cost-of-energy-slash-electricity-lcoe> (visited on 24th May 2022).
- PVsyst (2022a). *Controller and Power Conditioning*. URL: [https://www.pvsyst.com/help/controller\\_opermodes.htm](https://www.pvsyst.com/help/controller_opermodes.htm) (visited on 12th June 2022).
- (2022b). *General Description of the PVsyst Software*. URL: [https://www.pvsyst.com/help/general\\_descr.htm](https://www.pvsyst.com/help/general_descr.htm) (visited on 20th Apr. 2022).
- (2022c). *Load profile: ASCII File Definition*. URL: [https://www.pvsyst.com/help/load\\_file.htm#loadprofileformat](https://www.pvsyst.com/help/load_file.htm#loadprofileformat) (visited on 9th June 2022).
- (2022d). *Normalized Performance Index*. URL: [https://www.pvsyst.com/help/performance\\_index.htm](https://www.pvsyst.com/help/performance_index.htm) (visited on 9th June 2022).
-

- 
- PVsyst (2022e). *Results*. URL: <https://www.pvsyst.com/help/results.htm> (visited on 9th June 2022).
- (2022f). *Simulation variables: Stand alone system*. URL: [https://www.pvsyst.com/help/index.html?simulation\\_variables\\_standalone.htm](https://www.pvsyst.com/help/index.html?simulation_variables_standalone.htm) (visited on 2nd June 2022).
- (2022g). *Stand Alone System Definition*. URL: [https://www.pvsyst.com/help/index.html?standalone\\_description.htm](https://www.pvsyst.com/help/index.html?standalone_description.htm) (visited on 21st Apr. 2022).
- (2022h). *Transposition Factor*. URL: [https://www.pvsyst.com/help/transposition\\_factor.htm](https://www.pvsyst.com/help/transposition_factor.htm) (visited on 19th May 2022).
- (2022i). *Universal Controller*. URL: [https://www.pvsyst.com/help/controller\\_universal.htm](https://www.pvsyst.com/help/controller_universal.htm) (visited on 16th May 2022).
- Rajani, Sachin Vrajilal and Vivek J. Pandya (2016). ‘Experimental Verification of the Rate of Charge Improvement using Photovoltaic MPPT Hardware for the Battery and Ultracapacitor Storage Devices’. In: *Solar Energy* 139, pp. 142–148. ISSN: 0038-092X. DOI: <https://doi.org/10.1016/j.solener.2016.09.037>.
- Rajesh, K.S. et al. (2017). ‘A Review on Control of AC Microgrid’. In: *Renewable and Sustainable Energy Reviews* 71, pp. 814–819. ISSN: 1364-0321. DOI: <https://doi.org/10.1016/j.rser.2016.12.106>.
- REREC (2022). *Who We Are: Rural Electrification and Renewable Corporation (REREC)*. URL: <https://www.rerec.co.ke/about-us.php> (visited on 6th June 2022).
- RS (2022). *Makita GA5021 125 mm Corded Angle Grinder, UK Plug*. URL: <https://no.rs-online.com/web/p/grinders/6674054?> (visited on 13th June 2022).
- Sanner, Lindsay (2022). *Personal communication*.
- Sannino, A., G. Postiglione and M.H.J. Bollen (2003). ‘Feasibility of a DC network for Commercial Facilities’. In: *IEEE Transactions on Industry Applications* 39.5, pp. 1499–1507. DOI: 10.1109/TIA.2003.816517.
- Silva, Michelle Kitayama da et al. (2018). ‘Comparative Analysis of Transposition Models Applied to Photovoltaic Systems Using Meteornorm and NASA SSE Databases’. In: *2018 13th IEEE International Conference on Industry Applications (INDUSCON)*, pp. 237–241. DOI: 10.1109/INDUSCON.2018.8627354.
- Sivaram, Varun (2018). *Taming the Sun: Innovations to Harness Solar Energy and Power the Planet*. The MIT Press.
- Solar, Deege (2022). *Solar inverters, What are They and How Do They Work?* URL: [https://www.deegesolar.co.uk/solar\\_inverters/](https://www.deegesolar.co.uk/solar_inverters/) (visited on 5th June 2022).
- SolarDesignGuide (2022). *Which Direction Should Your Solar Panels Face?* URL: <https://solardesignguide.com/solar-panel-tilt-and-azimuth/> (visited on 13th June 2022).
- Solry (2022a). *FarcoPower LifePO4 Freeze 12,8/200AH*. URL: <https://www.solry.no/p/farcopower-lifepo4-freeze-12-8-210ah/> (visited on 15th May 2022).
- (2022b). *Ritar 12V 200AH AGM Batteri*. URL: <https://www.solry.no/p/ritar-12v-200ah-agm-batteri/> (visited on 15th May 2022).
- Source, Generator (2022). *Power Consumption Chart*. URL: [https://www.generatorsource.com/Power\\_Consumption\\_Chart.aspx](https://www.generatorsource.com/Power_Consumption_Chart.aspx) (visited on 13th June 2022).
- Statkraft (2022). *Solar Power*. URL: <https://www.statkraft.com/what-we-do/solar-power/> (visited on 20th May 2022).
- Stimatracker (2022). *Electricity price in Kenya*. URL: <https://www.stimatracker.com/> (visited on 19th May 2022).
- Sun, king (2022). *Home 200X Plus*. URL: <https://sunking.com/solar-home-systems/sun-king-home-200x-plus/> (visited on 5th June 2022).
- Swan, Lukas G. and V. Ismet Ugursal (2009). ‘Modeling of End-Use Energy Consumption in the Residential Sector: A Review of Modeling Techniques’. In: *Renewable and Sustainable Energy Reviews* 13.8, pp. 1819–1835. ISSN: 1364-0321. DOI: <https://doi.org/10.1016/j.rser.2008.09.033>.
- Tabatabaei, Naser Mahdavi, Ersan Kabalci and Nico Bizon (2020). *Microgrid Architectures, Control and Protection Methods*. Springer Nature Switzerland AG. URL: <https://link.springer.com/book/10.1007/978-3-030-23723-3>.
- TraceSoftware (2022). *The Effects of Solar Shadings on the Performance of PV Panels*. URL: <https://www.trace-software.com/blog/the-effects-of-solar-shadings-on-the-performance-of-pv-panels/> (visited on 13th June 2022).
- UN (2022a). *Goal 4*. URL: <https://sdgs.un.org/goals/goal7> (visited on 22nd May 2022).
- (2022b). *Goal 4*. URL: <https://sdgs.un.org/goals/goal4> (visited on 22nd May 2022).
-

- 
- UN (2022c). *What is Climate Change*. URL: <https://www.un.org/en/climatechange/what-is-climate-change> (visited on 22nd May 2022).
- UNDP (2022a). *Goal 7 Affordable and clean energy*. URL: <https://www.undp.org/sustainable-development-goals#affordable-and-clean-energy> (visited on 22nd May 2022).
- (2022b). *Quality Education*. URL: <https://www.undp.org/sustainable-development-goals#quality-education> (visited on 22nd May 2022).
- (2022c). *Sustainable Development Goals*. URL: <https://www.undp.org/sustainable-development-goals> (visited on 22nd May 2022).
- UNEP (2022). *Six Sector Solution Climate Change*. URL: <https://www.unep.org/interactive/six-sector-solution-climate-change/> (visited on 22nd May 2022).
- UngEnergi (2022). *Solceller*. URL: <https://ungenergi.no/energikilder/solenergi/solceller/> (visited on 21st May 2022).
- Vega-Garita, Victor et al. (2019). ‘Selecting a Suitable Battery Technology for the Photovoltaic Battery Integrated Module’. In: *Journal of Power Sources* 438, p. 227011. ISSN: 0378-7753. DOI: <https://doi.org/10.1016/j.jpowsour.2019.227011>.
- Veilleux, Gabriel et al. (2020). ‘Techno-Economic Analysis of Microgrid Projects for Rural Electrification: A Systematic Approach to the Redesign of Koh Jik Off-grid Case Study’. In: *Energy for Sustainable Development* 54, pp. 1–13. ISSN: 0973-0826. DOI: <https://doi.org/10.1016/j.esd.2019.09.007>.
- Vision2030 (2022). *Towards 2030*. URL: <https://vision2030.go.ke/towards-2030/> (visited on 24th May 2022).
- WBG (2020). ‘Climate Risk Profile: Kenya’. In: URL: [https://www.acaps.org/sites/acaps/files/key-documents/files/climate\\_risk\\_country\\_profile\\_kenya.pdf](https://www.acaps.org/sites/acaps/files/key-documents/files/climate_risk_country_profile_kenya.pdf).
- (2022). *Access to Electricity, Rural (% of Rural Population) - Kenya*. URL: <https://data.worldbank.org/indicator/EG.ELC.ACCS.RU.ZS?locations=KE> (visited on 22nd May 2022).
- Wiemann, Marcus, Simon Rolland and Guido Glania (2014). ‘Hybrid Mini-Grids for Rural Electrification: Lessons Learned’. In: *Alliance for Rural Electrification*. URL: [https://www.ruralelec.org/sites/default/files/hybrid\\_mini-grids\\_for\\_rural\\_electrification\\_2014.pdf](https://www.ruralelec.org/sites/default/files/hybrid_mini-grids_for_rural_electrification_2014.pdf).
- WorldWeatherOnline (2022). *Kilifi Climate Weather Averages*. URL: <https://www.worldweatheronline.com/kilifi-weather-averages/coast/ke.aspx> (visited on 25th May 2022).

# Appendix

## A Data sheets

### A.1 Solar Tubular Gel Battery 150Ah to 200Ah



#### TECHNICAL SPECIFICATION - Tubular Gel Battery

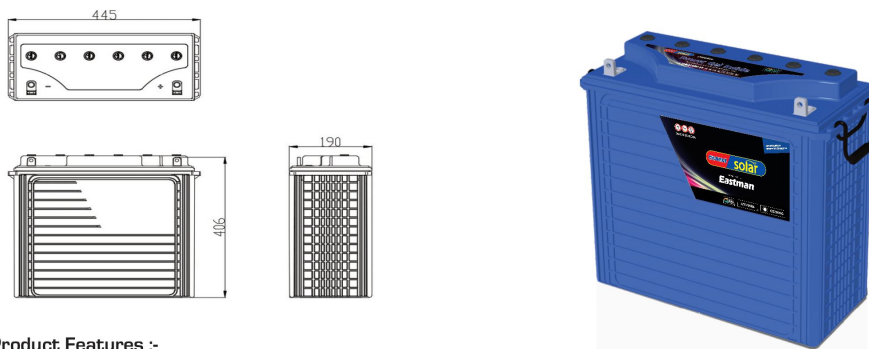

#### Product Features :-

1. Robust Tubular with High pressure diecasted spine - rate of spine corrosion is very low as compare to AGM VRLA
2. Gelled electrolyte - no stratification and no failure due to PSOC
3. Valve regulated - no water top up during service life
4. Antimony free alloy - longer shelf life because of very low self discharge
5. Very High Design & service life as compare to than AGM VRLA
6. Good for Cyclic & Float Applications
7. Wide operating Temperature Range.

#### Technical Specifications

Model	Nominal Voltage	Rated Capacity 10 Hr @ 27°C (Ah)	Dimensions in mm			Filled Battery Weight [Kg] [±3%]	Terminal Type
			Length [± 3 mm]	Width [± 3 mm]	Height [± 3 mm]		
CE150GG [12 V 150 AH @ C20]	12	135	445	190	406	48	L
CE200GG [12 V 200 AH @ C20]	12	180	445	190	406	61.5	L

#### Electrical Parameters & Charging Profile

Battery Specified Capacity Test @ 27 °C						
	C20 @10.5V	C10 @10.5V	C7 @10.5V	C5 @10.5V	C3 @10.5V	C1 @10.5V
CE150GG [12 V 150 AH @ C20]	150	135	124	112	97	68
CE200GG [12 V 200 AH @ C20]	200	180	166	150	129	90
Ah & Wh Efficiency						
Ah Efficiency	>96%		Wh Efficiency		>84%	

- Poly Components Material :- Polypropylene Co polymer
- Color :- Blue
- Testing Parameters :- IS 13369:2005, IEC 60896-21 & IEC 61427-1

**Charging Profile**

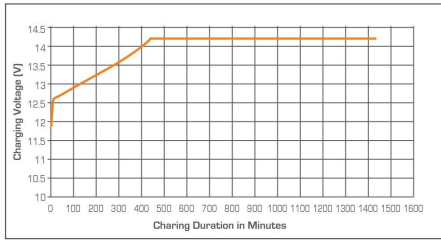

**Self Discharge Characteristics @ Different Temperature**

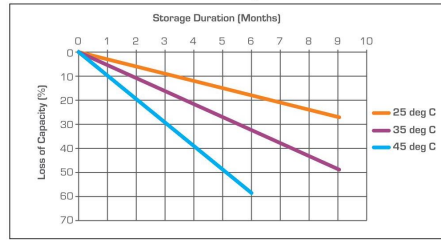

**State of Charge Measure of Open-circuit Voltage @ 27°C**

State of Charge	Specific Gravity	Voltage
100%	NA	13.1V
75%	NA	12.75V
50%	NA	12.45V
25%	NA	12.1
0%	NA	11.9V

**Discharging Characteristics at various rates @ 27°C**

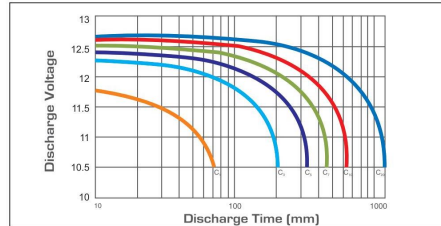

**Service (Float) Life and Temperature**

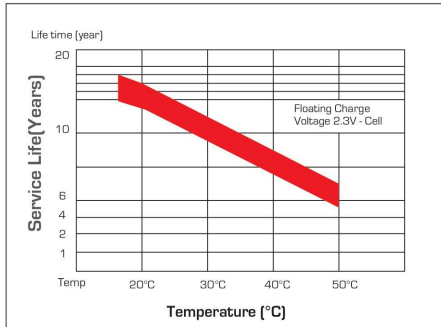

**Expected Capacity vs Temperature**

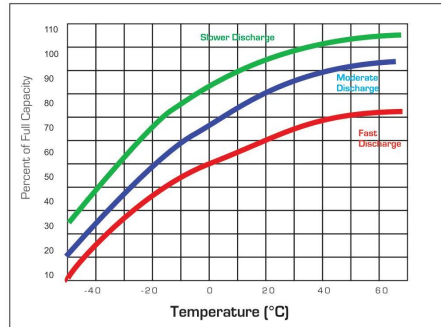

Eastman Battery Manufacturing Certified by Vincotte for





**Specific Gravity & Self Discharge w.r.t. Temperature**

	Add	Subtract
CHARGING TEMPERATURE COMPENSATION	0.005 volt per cell for every 1°C below 25°C	0.005 volt per cell for every 1°C above 25°C or
	0.0028 volt per cell for every 1°F below 77°F	0.0028 volt per cell for every 1°F above 77°F
OPERATIONAL DATA	Operating Temperature	Self Discharge
	-4°F to 131°F (-20°C to +55°C) At temperatures below 32°F (0°C) maintain a state of charge greater than 60%.	As per discharge Graph

**Expected Life**

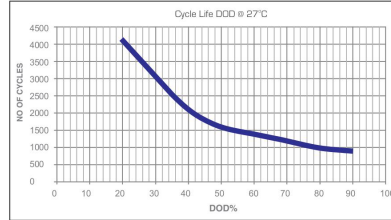

**Charging Instructions**

Charger Voltage Settings (at 77° F/ 25°C)			
System Voltage	12V	24V	48V
Maximum Charge Current	0.2C10		
Maximum Absorption Phase Time (hours)	4		
Absorption Voltage	14.2	28.4	56.8
Float Voltage	13.8	27.6	55.2
Equalization Voltage	14.8	29.6	59.2
Do not install or charge batteries in a sealed or non-ventilated compartment. Constant under or overcharging will damage the battery and shorten its life as with any battery.			
Periodic Charge	Provide a periodic refreshing charge to maintain a SOC greater than the threshold of 70%		

Eastman Gel battery testing procedure adhere IEC , CE & UL 94 test standards

**Comparison in between Chloride Tubular Gel & AGM Gel VRLA**

S.No	Parameter	Chloride Tubular GEL	AGM GEL VRLA
1	Plate Technology	Tall Tubular Plate	Flat Pasted Plate
2	Electrolyte	Electrolyte in-between Gel	Electrolyte in-between AGM
3	Water Loss	Negligible	Negligible
4	Self Discharge	Very Low <2.0%	Very Low <2.0%
5	Life Cycle w.r.t DOD	1000 Cycle @ 80% DOD	450 Cycle @ 80% DOD
6	Water Top up	No water top throughout Life	No water top throughout Life
7	Plastic Material	PPCP	PPCP material & ABS material
8	Battery Technology	Valve Regulated Technology	Valve Regulated Technology
9	Separator	PVC	AGM
10	Life w.r.t Application	Excellent performance on cyclic application	Not good for cyclic application
11	Acid Stratification	NO	No
12	Discharge Current	Low Range	Wide Range
13	Charging setting	Required special set point for chargers	Required special set point for charges
14	Operating Temperature	Wide Temperature Operating range	Temperature Operating range is limited
15	Spillage	Spill-proof	Spill-proof

Terminal Configuration :-  
Terminal Type :- L  
Terminal Height :- 25 mm  
Torque Value :- 8-10 N.m  
Bolt Type :- MB



Vent Plug Type :-  
M18 with vent valve & flame arrestor assembly



**EASTMAN AUTO & POWER LTD.**

572, Udyog Vihar Phase 5, Gurgaon - 122016, Haryana, India | +91 124 4627900 | sales@eastmanglobal.com  
www.eaplworld.com

## A.2 Growatt PV Off-grid Inverter 3.5 kW

Datasheet	SPF 3500 ES	SPF 5000 ES
Battery Voltage	48VDC	
Battery Type	Lithium/Lead-acid	
<b>INVERTER OUTPUT</b>		
Rated Power	3500VA/ 3500W	5000VA/ 5000W
Parallel Capability	Yes, 6 units maximum	
AC Voltage Regulation (Battery Mode)	230VAC $\pm$ 5% @ 50/60Hz	
Surge Power	7000VA	10000VA
Efficiency (Peak)	93%	
Waveform	Pure sine wave	
Transfer Time	10ms typical, 20ms Max	
<b>SOLAR CHARGER</b>		
Maximum PV Array Power	4500W	6000W
MPPT Range @ Operating Voltage	120VDC – 430VDC	
Number of Independent MPP Trackers/ Strings Per MPP Tracker	1/1	
Maximum PV Array Open Circuit Voltage	450VDC	
Maximum Solar Charge Current	80A	100A
<b>AC CHARGER</b>		
Charge Current	60A	80A
AC Input Voltage	230 VAC	
Selectable Voltage Range	170-280 VAC (For Personal Computers) ; 90-280 VAC (For Home Appliances)	
Frequency Range	50Hz/60Hz (Auto sensing)	
<b>PHYSICAL</b>		
Protection Degree	IP20	
Dimension (W/H/D)	330/485/135mm	330/485/135mm
Net Weight	11.5kgs	12kgs
<b>OPERATING ENVIRONMENT</b>		
Humidity	5% to 95% Relative Humidity(Non-condensing)	
Altitude	<2000m	
Operating Temperature	0°C - 55°C	
Storage Temperature	-15°C - 60°C	

### A.3 GCL M8/72H Monocrystalline Module



## GCL-M8/72H Monocrystalline Module

430-465W



**465W**  
Maximum Power Output

**21.0%**  
Maximum Module Efficiency

**0~+5W**  
Power Output Guarantee



Anti-reflection coating and self-cleaning glass



Selected encapsulating material and stringent production process control ensure the product is highly PID resistant and snail trails free



Special cutting and soldering technology leads to low hotspot risk



Sand blowing test, salt mist test and ammonia test passed to endure harsh environments



Optimized system performance due to module level current sorting



Highly transparent self-cleaning glass brings additional yield and easy maintenance

#### GCL Delivers Reliable Performance Over Time

- World-class manufacturer of crystalline silicon photovoltaic modules
- Fully automatic facility and world-class technology
- Rigorous quality control to meet the highest standard: ISO 9001, ISO 14001 and ISO 45001
- Tested for harsh environments (salt mist, ammonia corrosion and sand blowing test: IEC 61701, IEC 62716, DIN EN 60068-2- 68)
- Long term reliability tests
- 2x100% EL inspection ensuring defect-free modules

#### Linear Performance Warranty

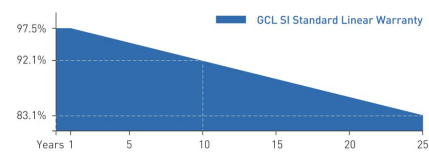

12 Years Product Warranty 25 Years Linear Power Warranty

\* Please refer to GCL standard warranty for details

Additional Insurance Backed by Swiss RE



\* Please refer to GCL for details

Bringing Green Power To Life

[www.gclsi.com](http://www.gclsi.com)



# GCL-M8/72H

Monocrystalline Module 430-465W

## Electrical Specification (STC\*)

Maximum Power	P <sub>max</sub> (W)	430	435	440	445	450	455	460	465
Maximum Power Voltage	V <sub>mp</sub> (V)	40.72	41.08	41.40	41.75	42.10	42.41	42.76	43.10
Maximum Power Current	I <sub>mp</sub> (A)	10.56	10.59	10.63	10.66	10.69	10.73	10.76	10.79
Open Circuit Voltage	V <sub>oc</sub> (V)	48.69	48.99	49.25	49.55	49.84	50.10	50.39	50.68
Short Circuit Current	I <sub>sc</sub> (A)	11.22	11.25	11.28	11.31	11.34	11.37	11.40	11.43
Module Efficiency	(%)	19.5	19.7	19.9	20.1	20.4	20.6	20.8	21.0
Power Output Tolerance	(W)	0--±5							

\* Irradiance 1000W/m<sup>2</sup>, Module Temperature 25°C, Air Mass 1.5

## Electrical Specification (NOCT\*)

Maximum Power	P <sub>max</sub> (W)	313.58	317.30	321.03	324.79	328.57	332.36	336.18	340.02
Maximum Power Voltage	V <sub>mp</sub> (V)	37.26	37.55	37.84	38.13	38.42	38.71	39.00	39.29
Maximum Power Current	I <sub>mp</sub> (A)	8.42	8.45	8.48	8.52	8.55	8.59	8.62	8.65
Open Circuit Voltage	V <sub>oc</sub> (V)	45.04	45.30	45.56	45.82	46.08	46.34	46.60	46.86
Short Circuit Current	I <sub>sc</sub> (A)	9.06	9.09	9.12	9.14	9.17	9.19	9.22	9.25

\* Irradiance 800W/m<sup>2</sup>, Ambient Temperature 20°C, Wind Speed 1m/s

## Mechanical Data

Number of Cells	144 Cells (6×24)
Dimensions of Module L*W*H (mm)	2108×1048×35 mm [82.99×41.26×1.38 inches]
Weight [kg]	25.1 kg
Glass	High transparency solar glass 3.2mm [0.13 inches]
Backsheet	White
Frame	Silver, anodized aluminium alloy
J-Box	IP68 Rated
Cable	4.0mm <sup>2</sup> [0.006 inches <sup>2</sup> ], Portrait: 300/300mm [11.81inches]
Number of diodes	3
Wind/ Snow Load	2400Pa/ 5400Pa*
Connector	MC Compatible

\* For more details please check the installation manual of GCLSI

## Temperature Ratings

Nominal Operating Cell Temperature (NOCT)	44±2°C
Temperature Coefficient of I <sub>sc</sub>	+0.06%/°C
Temperature Coefficient of V <sub>oc</sub>	-0.30%/°C
Temperature Coefficient of P <sub>max</sub>	-0.39%/°C

## Packaging Configuration

Module per box	30 pieces
Module per 40' container	600 pieces

## Maximum Ratings

Operational Temperature	-40~+85°C
Maximum System Voltage	1500V DC
Max Series Fuse Rating	20A

## Optional

Connector:  Original MC4



Contact Us for More Information

website: [www.gctsi.com](http://www.gctsi.com) email: [gctsisales@gctsi.com](mailto:gctsisales@gctsi.com)

## Module Dimension

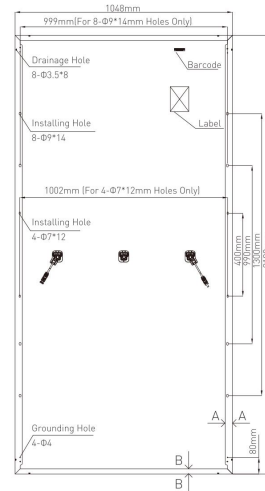

Back View

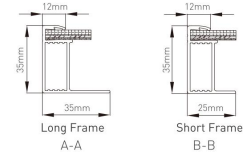

## I-V Curve at Different Temperature (465W)

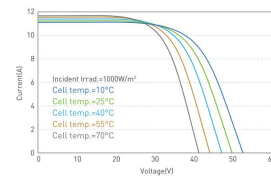

## I-V/P-V Curve at Different Irradiation (465W)

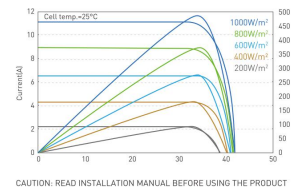

Bringing Green Power To Life

GCL/XXJC/2-MKT-123-D0

---

## B Model input to RAMP

The following chapter present the model input that have not been addressed in Chapter 6. This entails the appliances and parameters for for various buildings and scenarios.

### B.1 Power ratings of appliances

Table 49: Overview of the power ratings of the appliances, and the source of these

Appliance	Power rating [W]	Source
Phone	7	Logic 2022
Laptop	60	K. T. Lervik and Waitz 2021
Fan	50	Fieldwork
Indoor LED	9	Generatorist 2022
Outdoor LED	9	Generatorist 2022
Projector	220	Generatorist 2022
Fridge	150	Lombardi et al. 2022
Blender	400	Logic 2022
Tablet	15	Fieldwork
Printer	150	Lombardi et al. 2022
Radio	5	Generatorist 2022
Shaving machine	15	Logic 2022
Steam iron	1000	Logic 2022
Decoder	10	Lombardi et al. 2022
TV	60	Lombardi et al. 2022
Small speaker	10	POWER 2022a
Medium speaker	50	POWER 2022b
Drill (cordless)	100	Source 2022
Circular saw	2400/720	Source 2022
Angle grinder	1050	RS 2022

### B.2 Current visitor area

Table 50: Appliances assumed in the VS during seasons with high visitor activity.

Appliance	m	Usage [min]	Window 1	Window 2	Frequency [%]
LED light	5	60	19:00-00:00	-	100

Table 51: Appliances assumed in the VT during seasons with high visitor activity.

Appliance	m	Usage [min]	Window 1	Window 2	Frequency [%]
LED Indoor	2	60	19:00-07:00	-	100
LED Outdoor	1	60	19:00-07:00	-	

Table 52: Appliances assumed in VH2 during the hot season with high visitor activity.

Appliance	m	Usage [min]	Window 1	Window 2	Frequency [%]
Mobile	3	120	07:00-00:00	-	100
Laptop	2	240	07:00-00:00	-	100
Fan	1	540	12:00-14:00	21:00-07:00	100
Indoor LED	6	120	06:00-07:00	19:00-00:00	100
Outdoor LED	1	60	19:00-07:00	-	100
Small speaker	1	60	07:00-00:00	-	50
Fridge	1	1440	00:00-00:00	-	100

Table 53: Appliances assumed in VH1 during seasons with low visitor activity.

Appliance	m	Usage [min]	Window 1	Window 2	Frequency [%]
Mobile	3	120	07:00-00:00	-	100
Laptop	3	240	07:00-00:00	-	100
Fan	1	540	12:00-14:00	21:00-07:00	100
Small speaker	1	60	07:00-00:00	-	20

Table 54: Fan activity in VH1 during the cold season.

Appliance	m	Usage [min]	Window 1	Window 2	Frequency [%]
Fan	2	360	12:00-14:00		

### B.3 Teacher's area

Table 55: Appliances assumed in the SC the hot season during the weekdays.

Appliance	m	Usage [min]	Window 1	Window 2	Frequency [%]
Fan	6	540	17:00-07:00	-	100
Phone	6	120	17:00-00:00	-	100
Laptop	6	120	17:00-00:00	-	100
Iron	1	60	17:00-21:00	-	33
LED indoor	12	240	06:00-07:00	19:00-00:00	100
LED outdoor	5	60	19:00-07:00	-	100

Table 56: Appliances assumed in the SCt in the hot season during the weekends.

Appliance	m	Usage [min]	Window 1	Window 2	Frequency [%]
Fan	3	600	12:00-14:00	19:00-07:00	100
Phone	3	120	07:00-00:00	-	100
Laptop	3	120	07:00-00:00	-	100
Iron	1	60	10:00-21:00	-	33
LED indoor	6	240	06:00-07:00	19:00-00:00	100
LED outdoor	5	60	19:00-07:00	-	100

Table 57: Model input for the fan in the SR during cold seasons.

Appliance	m	Usage [min]	Window 1	Window 2
Fan	2	240	12:00-18:00	-

Table 58: Model input for the fan in the SC during cold seasons.

Appliance	m	Usage [min]	Window 1	Window 2	Days
Fan	6	360	17:00-07:00	-	Weekdays
Fan	3	420	12:00-14:00	19:00-07:00	Weekends

Table 59: Model input for the fan in the Office during cold seasons.

Appliance	m	Usage [min]	Window 1	Window 2
Fan	1	180	12:00-17:00	-

Table 60: Appliances assumed in the SR during vacations. The parameters are adjusted to the hot season.

Appliance	m	tot_use [min]	Window 1	Window 2	Frequency [%]
Fan	2	600	12:00-00:00	-	100
Small speaker	1	60	07:00-21:00	-	50
Medium speaker	1	60	07:00-21:00	-	50
Indoor LED	2	300	06:00-07:00	19:00-00:00	100
Outdoor LED	3	120	19:00-00:00	-	100
Fridge	1	1440	00:00-00:00	-	100
Projector	1	60	07:00-19:00	-	50
Printer	1	30	07:00-19:00	-	20
TV	1	360	10:00-00:00	-	100
Decoder	1	360	10:00-00:00	-	100
Phone	2	120	10:00-19:00	-	100
Laptop	2	120	10:00-19:00	-	100

Table 61: Model input for the fan in the SR during the vacations in the cold seasons.

Appliance	m	Usage [min]	Window 1	Window 2
Fan	2	360	12:00-20:00	-

Table 62: Appliances assumed during the week in the Office. The parameters are adjusted to the hot season.

Appliance	m	Usage [min]	Window 1	Window 2
Phone	1	120	07:00-17:00	-
Laptop	1	300	07:00-17:00	-
LED indoor	2	480	07:00-17:00	-
LED outdoor	2	60	19:00-22:00	-
Fan	1	420	07:00-17:00	-

---

## B.4 Classroom area

Table 63: Appliances assumed during the weekdays by the Users in  $Class_{t_2}$ . The parameters are adjusted for the hot season.

Appliance	m	Usage [min]	Window 1	Window 2
Light	2	300	07:00-15:00	-
Fan	1	300	07:00-15:00	-

Table 64: Appliances assumed during the weekdays in  $Class_6$ . The parameters are adjusted for the hot season.

Appliance	m	Usage [min]	Window 1	Window 2
Fan	1	300	07:00-15:00	-

Table 65: Appliances assumed during the weekdays in the PP buildings.

Appliance	m	Usage [min]	Window 1	Window 2
LED indoor	4	420	07:00-17:00	-

Table 66: Appliances assumed during the weekdays in the ST.

Appliance	m	Usage [min]	Window 1	Window 2
LED indoor	4	120	07:00-17:00	-

Table 67: Appliances assumed during the weekdays by the Users in  $Class_{t_1}$  during the cold season.

Appliance	m	Usage [min]	Window 1	Window 2
Light	4	420	07:00-17:00	-
Fan	2	240	12:00-17:00	-

Table 68: Appliances assumed during the weekdays by the Users in  $Class_{t_2}$  the cold season.

Appliance	m	Usage [min]	Window 1	Window 2
Light	2	300	07:00-15:00	-
Fan	1	180	12:00-15:00	-

Table 69: Appliances assumed during the weekdays in  $Class_6$  during the cold season.

Appliance	m	Usage [min]	Window 1	Window 2
Fan	1	180	12:00-15:00	-

Table 70: Model input for the fan in the LLL during cold seasons.

Appliance	m	Usage [min]	Window 1	Window 2
Fan	2	120	12:00-15:00	-

## B.5 Student dorm area

Table 71: Appliances assumed in the SS when the students are staying at the property.

Appliance	m	Usage [min]	Window 1	Window 2	Frequency [%]	Days
LED Indoor	2	120	15:00-21:00	-	100	Weekdays
Led Outdoor	2	60	15:00-21:00	-	100	Weekdays
LED Indoor	2	120	12:00-21:00	-	100	Weekends
Led Outdoor	2	60	12:00-21:00	-	100	Weekends

Table 72: Appliances assumed in the ST when the students are staying at the property.

Appliance	m	Usage [min]	Window 1	Window 2	Frequency [%]
LED Indoor	2	120	19:00-07:00	-	100
LED Outdoor	2	60	19:00-07:00	-	100

Table 73: Appliances assumed in the SD in the cold season during the week.

Appliance	m	Usage [min]	Window 1	Window 2	Frequency [%]	Days
LED Indoor	3	120	06:00-07:00	19:00-21:00	100	Weekday
Led Outdoor	2	60	19:00-07:00	-	100	Weekday
Fan	2	360	21:00-06:00	-	100	Weekday
LED Indoor	3	120	19:00-22:00	-	100	Weekend
Led Outdoor	2	60	19:00-07:00	-	100	Weekend
Fan	2	360	12:00-14:00	22:00-07:00	100	Weekend

## B.6 Director's housing area

Table 74: Appliances assumed in the Stor<sub>Dir</sub>

Appliance	m	Usage [min]	Window 1	Window 2	Frequency [%]
LED Light	2	30	07:00-21:00	-	20

Table 75: Appliances assumed in the RB<sub>2</sub> during the cold season.

Appliance	m	Usage [min]	Window 1	Window 2	Frequency [%]
LED Indoor	6	300	06:00-07:00	19:00-00:00	100
LED Outdoor	3	60	19:00-07:00	-	100
Fan	2	360	21:00-07:00	-	100
Mobile	1	120	07:00-00:00	-	100
Laptop	1	120	13:00-21:00	-	50
Fridge	1	1440	00:00-00:00	-	100

Table 76: Appliances assumed in the RB<sub>1</sub> during cold season

Appliance	m	Usage [min]	Window 1	Window 2
LED Indoor	3	420	06:00-07:00	17:00-00:00
LED Outdoor	1	60	19:00-07:00	-
Fan	1	420	17:00-07:00	-
Mobile	1	120	07:00-00:00	-
Laptop	1	240	07:00-00:00	-
Fridge	1	1440	00:00-00:00	-

Table 77: Appliances assumed in the RB<sub>2</sub> in hot season during vacations.

Appliance	m	Usage [min]	Window 1	Window 2	Frequency [%]
LED Indoor	6	300	06:00-07:00	19:00-00:00	100
LED Outdoor	3	60	19:00-07:00	-	100
Fan	2	540	21:00-07:00	-	100
Mobile	4	120	07:00-00:00	-	100
Laptop	1	120	13:00-21:00	-	100
Fridge	1	1440	00:00-00:00	-	100

## B.7 Kitchen area

Table 78: Appliances assumed in the storage in the Stor<sub>K</sub>.

Appliance	m	Usage [min]	Window 1	Window 2	Frequency [%]
LED light	3	30	19:00-21:00	-	20

Table 79: Appliances assumed in the Kitchen during the cold season.

Appliance	m	P[W]	tot_use[min]	Window 1	Window 2
Mobile	8	7	120	07:00-19:00	-
Laptop	8	60	240	07:00-00:00	-
Fan	3	50	300	12:00-14:00	19:00-21:00
Indoor LED	8	9	300	06:00-07:00	19:00-00:00
Outdoor LED	1	9	120	06:00-07:00	19:00-00:00
Small speaker	1	10	60	12:00-15:00	19:00-00:00
Fridge	1	150	1440	00:00-00:00	-
Blender	1	400	30	07:00-19:00	-

## B.8 Security building

Table 80: Appliances assumed in the security building during the hot seasons.

Appliance	m	Usage [min]	Window 1	Window 2	Frequency [%]
LED Indoor	1	360	19:00-07:00	-	100
LED Outdoor	1	240	19:00-07:00	-	100
Fan	1	540	19:00-07:00	-	100
Mobile	1	120	19:00-07:00	-	100

Table 81: Appliances assumed in the security building during the cold seasons.

Appliance	m	Usage [min]	Window 1	Window 2	Frequency [%]
LED Indoor	1	360	19:00-07:00	-	100
LED Outdoor	1	240	19:00-07:00	-	100
Fan	1	360	19:00-07:00	-	100
Mobile	1	120	19:00-07:00	-	100

## B.9 Future expansions

Table 82: Appliances assumed in a potential CL during the cold season.

Appliance	m	Usage [min]	Window 1	Window 2	Frequency [%]
Laptop	30	360	07:00-17:00	-	100
Laptop	5	60	17:00-19:00	-	20
LED Indoor	4	420	17:00-19:00	-	100
Fan	2	300	12:00-19:00	-	100

Table 83: Appliances assumed in the CL in the hot season during vacations.

Appliance	m	Usage [min]	Window 1	Window 2	Frequency [%]
Laptop	5	180	07:00-17:00	-	50
LED Indoor	4	300	07:00-17:00	-	50
Fan	2	300	07:00-17:00	-	50

Table 84: Appliances assumed in the CL during vacations in the cold season.

Appliance	m	Usage [min]	Window 1	Window 2	Frequency [%]
Laptop	5	180	07:00-17:00	-	50
LED Indoor	4	300	07:00-17:00	-	50
Fan	2	180	12:00-17:00	-	50

## Hang-out area

Table 85: Appliances assumed in the HA for visitors during cold season with low visitor activity.

Appliance	m	Usage [min]	Window 1	Window 2	Frequency [%]
Mobile	3	120	07:00-00:00	-	50
Laptop	3	120	07:00-00:00	-	50
Fan	2	300	12:00-14:00	19:00-21:00	50
Small speaker	1	60	12:00-00:00	-	50
Indoor LED	4	240	06:00-07:00	19:00-00:00	100
Outdoor LED	1	120	06:00-07:00	19:00-00:00	100
Fridge	1	1440	00:00-00:00	-	100

## Workshop



Table 86: Appliances assumed in the WS in the hot season during the weekends.

<b>Appliance</b>	<b>m</b>	<b>Usage [min]</b>	<b>Window 1</b>	<b>Window 2</b>	<b>Frequency [%]</b>
LED Indoor	8	240	12:00-19:00	-	50
Fan	4	240	12:00-19:00	-	50
Tablet	4	120	12:00-:19:00	-	50
Drill (cordless)	1	30	12:00-19:00	-	20
Circular saw	1	30	12:00-19:00	-	20
Angle grinder	1	30	12:00-19:00	-	20

Table 87: Appliances assumed in the WS during the vacations. Frequency is decreased for all appliances.

<b>Appliance</b>	<b>m</b>	<b>Usage [min]</b>	<b>Window 1</b>	<b>Window 2</b>	<b>Frequency [%]</b>
LED Indoor	8	480	12:00-19:00	-	20
Fan	4	240	12:00-19:00	-	20
Tablet	4	120	12:00-19:00	-	20
Drill (cordless)	1	30	12:00-19:00	-	10
Circular saw	1	30	12:00-19:00	-	10
Angle grinder	1	30	12:00-19:00	-	10

Table 88: Appliances assumed in the WS in the cold season during the weekdays.

<b>Appliance</b>	<b>m</b>	<b>Usage [min]</b>	<b>Window 1</b>	<b>Window 2</b>	<b>Frequency[%]</b>
LED Indoor	8	480	07:00-19:00	-	100
Fan	4	240	07:00-19:00	-	100
Tablet	10	120	07:00-19:00	-	50
Drill (cordless)	1	30	15:00-19:00	-	10
Circular saw	1	30	15:00-19:00	-	10
Angle grinder	1	30	15:00-19:00	-	10

Table 89: Appliances assumed in workshop in the cold season during the weekends.

<b>Appliance</b>	<b>m</b>	<b>Usage [min]</b>	<b>Window 1</b>	<b>Window 2</b>	<b>Frequency[%]</b>
LED Indoor	8	480	12:00-19:00	-	100
Fan	4	240	12:00-19:00	-	100
Tablet	4	120	12:00-19:00	-	50
Drill (cordless)	1	30	12:00-19:00	-	20
Circular saw	1	30	12:00-19:00	-	20
Angle grinder	1	30	12:00-19:00	-	20

