

Haakon Trøstheim Flaarønning  
Espen Birkeland Løvhaugen

# Investigating the Use of Point of Sales data in Dynamic Lot Sizing for New Product Launches

Master's thesis in Engineering and ICT  
Supervisor: Anita Romsdal  
Co-supervisor: Fabio Sgarbossa  
June 2022



Haakon Trøstheim Flaarønning  
Espen Birkeland Løvhaugen

# **Investigating the Use of Point of Sales data in Dynamic Lot Sizing for New Product Launches**

Master's thesis in Engineering and ICT  
Supervisor: Anita Romsdal  
Co-supervisor: Fabio Sgarbossa  
June 2022

Norwegian University of Science and Technology  
Faculty of Engineering  
Department of Mechanical and Industrial Engineering





---

# Preface

This master's thesis is part of the master's degree program Engineering & ICT at the Norwegian University of Science and Technology (NTNU). The main profile of our master's degree is Production Management at the Department of Mechanical and Industrial Engineering.

We would like to thank our supervisor Anita Romsdal and co-supervisor Fabio Sgarbossa for the feedback, comments, and support during the semester. Your knowledge within the field of Production Management has been inspiring.

We would also like to thank Brynild for the cooperation during the project. In particular, we would like to thank Supply Chain Director Mathias Holm and Project Manager Digitization/Automation Factory Haris Jasarevic for sharing valuable insights to the company and industry.

---

## Summary

This master's thesis investigated the practical application of demand forecasts based on point of sales data in dynamic lot sizing of new product launches for food manufacturers. Demand forecasting and production planning are particularly challenging in regards to new products due to the high and varying demand uncertainty. Historical data is not available as a predictor of future demand, and there is high uncertainty associated with consumer acceptance and competitive reactions. Regardless of its complexity, production planning and accurate demand forecasting of new products are crucially important to stay competitive in the food market. Product variety is increasing while the average product life-cycle is decreasing. Additionally, food products are perishable, making lot sizing decisions on when to produce and in what quantity particularly important. Manufacturers typically use unreliable and inconsistent forecasting methods when estimating the demand for new products. Pipeline fills are commonly performed, where a product is produced in excess of the anticipated demand to ensure product availability during the early phase of the product's life-cycle. A large pipeline fill increases the risk of overproduction and obsolescence of products. Similarly, underproduction can occur if the pre-launch forecast is too pessimistic as manufacturers are not aware of how well their products are selling until they receive re-fill orders on the new products.

Based on the challenges above, this study investigated how to use downstream supply chain data to aid in production planning and control for food manufacturers. Specifically, it examined how point of sales data from the retailer can be used to facilitate dynamic lot sizing of new product launches. The following research question was introduced to guide the research:

*How can demand forecasting based on point of sales data facilitate dynamic lot sizing of new product launches?*

The research question was addressed through a combination of a literature study and a case study. Multiple forecasting methods were identified and evaluated based on their ability to forecast point of sales data. In the case study, the forecasts from the identified methods were used as input to a dynamic lot sizing model to create a proposed production schedule. The costs derived from executing the proposed production plan were compared to that of the case company to investigate the effects on costs and service level. The results displayed a significant cost reduction, averaging at 30%, from using our proposed methods compared to the case company's approach. These cost reductions were obtained while maintaining a required service level of 97%.

---

The case study findings suggest that utilization of downstream point of sales data can reduce demand uncertainty associated with new product launches. Forecasts of point of sales data proved a reliable indicator of the manufacturer's demand and can be used in a dynamic lot sizing model to aid the producer in producing closer to the actual customer demand while minimizing waste. As a result, production and holding costs during a product's early life-cycle can be reduced, alongside the need for a large pipeline fill prior to launch.

---

## Sammendrag

Denne masteroppgaven undersøkte den praktiske anvendelsen av etterspørselsprognoser basert på salgsdata i butikk i dynamisk lot sizing av nye produktlanseringer for matvareprodusenter. Etterspørselsprognoser og produksjonsplanlegging er spesielt utfordrende i forhold til nye produkter på grunn av den høye og varierende etterspørselsusikkerheten. Historisk data er ikke tilgjengelig som en indikator for fremtidig etterspørsel, og det er stor usikkerhet knyttet til reaksjoner fra forbrukere og konkurrenter. Uavhengig av denne kompleksiteten er produksjonsplanlegging og nøyaktig etterspørselsprognostisering for nye produkter avgjørende for å holde seg konkurransedyktig i matmarkedet. Produktvariasjonen øker mens den gjennomsnittlige produktlivssyklusen minker. I tillegg er matvarer bedervelige, som gjør lot sizing avgjørelser på når man produserer og i hvilken mengde spesielt viktig. Produsenter bruker ofte upålitelige og inkonsekvente prognosemetoder når de estimerer etterspørselen for nye produkter. Produkter produseres vanligvis i overkant av forventet etterspørsel for å sikre produkttilgjengelighet i starten av produktets livssyklus. Denne overflødige produksjonen øker risikoen for overproduksjon. Underproduksjon kan også oppstå hvis prognosen før lansering er for pessimistisk forårsaket av at produsentene ikke er klare over hvordan produktene deres selger før de mottar nye bestillinger fra grossisten.

Basert på utfordringene ovenfor, undersøkte denne studien hvordan man kan bruke nedstrøms forsyningskjededata for å hjelpe produksjonsplanleggingen for matprodusenter. Spesifikt undersøkte oppgaven hvordan salgsdata i butikk kan brukes til å tilrettelegge for dynamisk lot sizing av nye produktlanseringer. Følgende forskningsspørsmål ble introdusert for å lede forskningen:

*Hvordan kan etterspørselsprognoser basert på salg i butikk legge til rette for dynamisk lot sizing av nye produkter for matprodusenter?*

Forskningsspørsmålet ble besvart gjennom en kombinasjon av en litteraturstudie og et casestudie. Flere prognosemetoder ble identifisert og evaluert basert på deres evne til å predikere salgsdata. I casestudien ble prognosene fra de identifiserte metodene brukt som input i en dynamisk lot sizing modell for å generere en produksjonsplan. Kostnadene som kommer av gjennomføring av den foreslåtte produksjonsplanen ble sammenlignet med kostnadene til case-selskapet for å undersøke effektene på kostnader og servicenivå. Resultatene viste en betydelig kostnadsreduksjon, i gjennomsnitt på 30%, ved å bruke våre foreslåtte metoder sammenlignet med case-selskapets tilnærming. Disse kostnadsreduksjonene ble oppnådd samtidig som et nødvendig servicenivå på 97% ble opprettholdt.

---

Disse funnene tyder på at bruk av nedstrøms salgsdata kan redusere etterspørselsusikkerhet knyttet til nye produktlanseringer. Prognoser for salg i butikk viste seg å være en pålitelig indikator på produsentens etterspørsel og kan brukes i en dynamisk lot sizing modell for å hjelpe produsenten med å produsere nærmere den faktiske kundeetterspørselen. Som et resultat kan kostnadene av å produsere og lagre produkter i løpet av et produkts tidlige livssyklus reduseres, sammen med behovet for å produsere overflødig før lansering.

---

## Abbreviations

<b>ANN</b>	Artificial neural network
<b>BOM</b>	Bill of materials
<b>CODP</b>	Customer Order Decoupling Point
<b>CPR</b>	Continuous replenishment planning
<b>CRP</b>	Capacity requirements planning
<b>D-pak</b>	Distribution packet
<b>EOQ</b>	Economic Order Quantity
<b>ERP</b>	Enterprise resource planning
<b>F-pak</b>	Consumer packets
<b>LSTM</b>	Long short-term memory
<b>MAPE</b>	Mean absolute percentage error
<b>MILP</b>	Mixed Integer Linear Programming
<b>MPC</b>	Manufacturing Planning and Control
<b>MPS</b>	Master Production Schedule
<b>MRP</b>	Material requirement planning
<b>MSE</b>	Mean squared error
<b>MTS</b>	Make-to-Stock
<b>MRP II</b>	Manufacturing resource planning
<b>POS</b>	Point of sales
<b>PPC</b>	Production Planning and Control
<b>RCCP</b>	Rough cut capacity planning
<b>RNN</b>	Recurrent neural network
<b>ROP</b>	Reorder Point
<b>RQ</b>	Research question
<b>SKU</b>	Stock-keeping units
<b>S&amp;OP</b>	Sales and operations planning
<b>WIP</b>	Work in progress

---

# Table of Contents

Preface	i
Summary	ii
Sammendrag	iv
List of Figures	x
List of Tables	xiii
<b>1 Introduction</b>	<b>1</b>
1.1 Motivation . . . . .	1
1.2 Problem formulation . . . . .	3
1.3 Research question and objectives . . . . .	4
1.4 Research scope . . . . .	5
1.5 Report outline . . . . .	6
<b>2 Methodology</b>	<b>7</b>
2.1 Literature study . . . . .	7
2.2 Case study . . . . .	9
2.3 Research overview . . . . .	14
<b>3 Theoretical Background</b>	<b>15</b>

---

3.1	Manufacturing Planning and Control . . . . .	15
3.2	Lot sizing . . . . .	35
3.3	Demand forecasting . . . . .	45
3.4	Information sharing in supply chains . . . . .	64
<b>4</b>	<b>Empirical Background</b>	<b>70</b>
4.1	Characteristics of the Norwegian food supply chain . . . . .	70
4.2	Structure of the Norwegian food supply chain . . . . .	72
4.3	Demand forecasting . . . . .	72
4.4	Current state of information sharing in the Norwegian food supply chain . . . . .	75
<b>5</b>	<b>Case Study</b>	<b>77</b>
5.1	Introduction to the case company . . . . .	77
5.2	Data cleaning and transformation . . . . .	84
5.3	Descriptive analysis . . . . .	85
5.4	Model development . . . . .	92
5.5	Results . . . . .	108
5.6	Discussion of findings . . . . .	121
<b>6</b>	<b>Discussion</b>	<b>128</b>
6.1	Demand forecasting of new products . . . . .	128
6.2	Dynamic lot sizing . . . . .	130
6.3	Guidelines on using dynamic lot sizing based on forecasts of point of sales data for new product launches . . . . .	133
6.4	Limitations and further work . . . . .	137
<b>7</b>	<b>Conclusion</b>	<b>139</b>





---

# List of Figures

2.1	Overview of the research . . . . .	14
3.1	Manufacturing Planning and Control System. The figure is collected from Jacobs et al. (2011). . . . .	16
3.2	Significance of planning and control over different time horizons. The figure is collected from Slack et al. (2019). . . . .	18
3.3	Different process types imply different volume–variety characteristics for the process. The figure is collected from Slack et al. (2019). . . . .	21
3.4	CODP for production environments. The dotted lines depict the forecast-driven production activities, whereas the straight lines depict customer-order-driven activities. The figure is collected from Olhager (2003). . . . .	22
3.5	Capacity planning in the MPC system. The figure is collected from Jacobs et al. (2011). . . . .	33
3.6	Illustration of rolling horizon planning environment, from Narayanan and Robinson (2010) . . . . .	44
3.7	Product hierarchy adapted from (Moon, 2018). . . . .	49
3.8	Overview of a perceptron and an artificial neural network . . . . .	57
3.9	Recurrent neural networks . . . . .	58
3.10	Overview of an LSTM cell . . . . .	61
3.11	Bass model S-curve . . . . .	62
3.12	Number of recent articles (2006-2016) on information sharing per information type studied by Viet et al. (2018) . . . . .	68

---

4.1	Distribution channels of food products . . . . .	73
4.2	Collaboration barrier . . . . .	76
5.1	Brynild's products . . . . .	78
5.2	Illustration of the 6-echelon supply chain of Brynild . . . . .	80
5.3	New product launches per year . . . . .	86
5.4	New product launches for each launch period . . . . .	87
5.5	New products launches for each product category . . . . .	87
5.6	Number of sales solutions for each new product launch . . . . .	88
5.7	New products for each sales solution . . . . .	88
5.8	Raw and cumulative point of sales data . . . . .	93
5.9	Illustration of the data split: the arrays inside input and output il- lustrates POS observation at given days after launch . . . . .	94
5.10	Linear regression forecasts after 7 and 14 days of POS data . . . . .	95
5.11	Seasonal POS data . . . . .	97
5.12	Holt-Winters forecasts after 7 and 14 days of POS data . . . . .	98
5.13	Illustration of the data split: the arrays inside input and output il- lustrates POS observation at given days after launch . . . . .	99
5.14	LSTM network architecture . . . . .	101
5.15	Holding costs . . . . .	110
5.16	Setup costs . . . . .	111
5.17	Total costs . . . . .	111
5.18	Holding costs with pipeline reduction . . . . .	114
5.19	Setup costs with pipeline reduction . . . . .	114
5.20	Total costs with pipeline reduction . . . . .	115
5.21	Comparison of production and inventory levels for one new product launch . . . . .	118

---

5.22 Comparison of production and inventory levels for one new product launch with a pipeline cut . . . . .	120
--	-----

---

# List of Tables

2.1	Data from Brynild . . . . .	12
2.2	Data from Tradesolution . . . . .	12
2.3	Data from NorgesGruppen . . . . .	12
3.1	Classification of lot sizing problems based on Haase (1994) and Brahim et al. (2017). . . . .	36
3.2	How forecasts are used by different functions in a manufacturing com- pany. Adapted from Moon (2018). . . . .	47
3.3	Typical lengths and update frequencies for different forecast cate- gories (Lewis, 2012). . . . .	48
5.1	Descriptive statistics of the production data for the 64 new products .	89
5.2	Descriptive statistics of the order data for the 64 new products . . . .	91
5.3	Descriptive statistics of point of sales data for the 64 new products .	92
5.4	Variables in the deterministic dynamic lot sizing model for each new product launch . . . . .	106
5.5	Additional variables in the stochastic dynamic lot sizing model for each new product launch . . . . .	107
5.6	Forecast errors for each week ahead forecasted, measured in MAPE .	108
5.7	Service levels . . . . .	109
5.8	Comparing costs and service level of deterministic and stochastic so- lutions to Brynild’s current approach . . . . .	112

---

5.9	Results for service level after pipeline reduction . . . . .	113
5.10	Comparing costs and service level of deterministic and stochastic solutions to Brynild's current approach with a pipeline reduction . . . .	116

---

# Chapter 1

## Introduction

### 1.1 Motivation

The Norwegian food supply chain is essential to provide food for the population, and consists of many actors including suppliers, manufacturers, wholesalers, grocery stores, and customers. The grocery market account for 40% of the revenue from retail in Norway (Moen et al., 2018). In addition, the grocery market is a highly competitive market with low marginal profits where economies of scale are beneficial (Oslo-Economics, 2017). As a result, a characterization of the Norwegian food supply chain is the presence of large actors at each stage, typically umbrella organizations joining wholesalers and retailers. These integrated organizations takes advantage of the economy of scale and increased bargaining power within the supply chain (Wifstad et al., 2018). The highly competitive market has led manufacturers to frequently launch new products and conduct promotional activity. NorgesGruppen, one of Norway's biggest wholesalers, estimates around 2000 new product launches each year (NOU, 2011). Due to the large product variety, the major wholesalers and retail chains have negotiation power over the smaller manufacturers in deciding assortment, placement in stores and sales price (Draganska and Klapper, 2007).

In order to gain goodwill and bargaining power with wholesalers, food manufacturers need to be able to supply the wholesalers and their associated grocery stores with products in the correct quantity at the right time. The wholesalers measure the service level of the manufacturers and use it as a bargaining tool if the service level is below what they require. This puts pressure on the producer to ensure product availability at all times which in turn can result in excessive production and huge stockpiles (Oslo-Economics, 2017). There is a significant amount of food waste in the Norwegian food supply chain as the products are perishable, estimated to have a

---

cost of 20,5 billion NOK each year (Stensgård and Hanssen, 2016). For that reason, the quantity and timing of production is essential for the manufacturer to maximize profits, increase market shares, provide fresh products and improve relationships with wholesalers and retailers.

To ensure meeting customer demand while simultaneously minimizing waste, accurate demand forecasting is crucial. Food manufacturers need to account for different types of demand, including regular demand, seasonal demand, campaign demand, and demand for new products. Particularly difficult is estimating the demand for new products as historical data is not available as an indicator for future demand. Accurate handling of new products are critical for most companies, and in 2003, 28% of both sales and profits came from new products in the United States (Crawford and Benedetto, 2008). Food manufacturers primarily use historical orders from wholesalers to predict future demand (Dreyer et al., 2016). However, with no previous order history on new products, predicting when re-fill orders will come and at what quantity proves difficult. In an attempt to ensure a satisfactory service level during the uncertain launch period, food manufacturers typically produce vast amounts prior to a product launch (Shen et al., 2014). This product saturation is called a pipeline fill and ensures that the manufacturer can provide the products when new wholesaler orders are received. However, the pipeline fill may lead to waste because of excessive production if the end-consumer demand significantly subceeds the anticipated demand. Oppositely, inadequate production may occur if the actual demand significantly exceeds what was forecasted. In such a case, the manufacturer will risk getting lost sales and a poor service level. As a result, there is an industrial need to conduct research on new product launches and the present challenges of demand forecasting and production planning during the highly uncertain launch period.

Much research has been made on forecasting the demand for new products, particularly through the application of qualitative methods (Kahn, 2014, 2002). Recent studies have also explored quantitative methods for demand forecasting of new products, typically estimating the new product demand by how similar it is to other previously launched products (R.M. van Steenbergen, 2020; Babu, 2018). Additionally, incorporating point of sales (POS) data, showing the quantity purchased of a given product at a given store at a given time, have been examined previously (Dharmawardane et al., 2021; Hartzel and Wood, 2017; Småros, 2005). However, most research is focused on using POS data for demand forecasting in the store generating the POS data. Research is, however, scarce on forecasting the demand of the manufacturer given point of sales data from the grocery stores where its products are selling, obtained through supply chain collaboration. Some research has mapped the potential benefits of using downstream supply chain data in demand forecasting



---

by upstream supply chain actors (Olsen, 2021; Småros, 2005). The benefits argued for include more accurate forecasts, increased response time, and reduced production and inventory costs. Due to these potentially significant benefits, researching ways of utilizing downstream supply chain data is of great importance and should be conducted.

To examine the potential benefits of using supply chain data, like POS, the forecasting methods and the production planning and control system using the forecast should be investigated simultaneously (Tiacci and Saetta, 2009). Despite the fact that demand forecasting for new product launches is important in itself, it is not sufficient to only evaluate the demand forecasting accuracy isolated. In fact, Xi et al. (2012) found that the forecast accuracy is reduced without a proper link to the inventory management which is making decisions based on the forecast. Forecast accuracy affects the manufacturing planning and control system to a large degree. Inaccurate forecasts can be costly for the company as overly optimistic forecasts can lead to redundant production resulting in waste and costly inventories, while pessimistic forecasts can lead to insufficient production resulting in lost sales and poor service levels (Kourentzes et al., 2020). Consequently, lot sizing, which involves determining the quantity and timing of the production to balance inventory, is of great significance (Jans and Degraeve, 2008). Lot sizing can be done statically with a fixed quantity and timing, or it can be done dynamically, where the quantity and timing change depending on the period considered. The forecasted demand for new product launches can drastically evolve over time as actual demand information becomes available, resulting in irregular lot sizing decisions on when and how much to produce (Pauls-Worm et al., 2014). Accordingly, investigating how dynamic lot sizing models perform based on forecasted demand is highly relevant. As most lot sizing models focus on mature products, investigating lot sizing for new products is needed (De Bodt et al., 1984).

## 1.2 Problem formulation

The challenges on new product launches faced by the Norwegian food supply chain substantiates the need for research on the matter. Additionally, the scarce research on both demand forecasting with downstream point of sales data and dynamic lot sizing of new products shows there is a need for further research on these topics. In particular, further examination of the two topics simultaneously is important, as lot sizing decisions often are based on the forecasts. Investigating the use of point of sales data in dynamic lot sizing for new product launches is therefore necessary due

---

to both scarce literature and industrial challenges.

The goal of this master thesis is to investigate the use of downstream supply chain data in production planning and control for food manufacturers. Specifically, examination how point of sales data from retail stores can be used to facilitate dynamic lot sizing of new product launches. Furthermore, our research investigates the effects of dynamic lot sizing, attained by utilizing POS data, on a food manufacturer's ability to meet customer demand and reducing production and inventory costs. In so doing, our research aims to bridge the existing research gap on ways of utilizing downstream supply chain data in the production planning for an upstream supply chain actor.

### 1.3 Research question and objectives

Based on the problem formulation, the following research question have been formalized to guide the research:

**Research question:** How can demand forecasting based on point of sales data facilitate dynamic lot sizing of new product launches?

The underlying goal of the master thesis is to answer the research question stated above. In order to do so, it has been broken down into the following three key objectives to complete:

**Objective 1:** Identify forecasting models suited for forecasting point of sales data of new product launches.

The first objective is to identify some highly regarded forecasting models that can be used to forecast based on point of sales data. To do so, a literature study is conducted examining the most commonly used, and state of the art time-series forecasting models. In addition, the characteristics of the data collected for the case study is examined to investigate what forecasting models that may be particularly suited for the data.

**Objective 2:** Conduct a case study to investigate the effect of dynamic lot sizing with forecasts based on point of sales data on cost reduction and service level for new product launches.

Once suitable forecasting methods are determined, the next objective is to conduct a case study to investigate the effects dynamic lot sizing using forecasts from the selected forecast methods have on cost reduction and service level for the case com-

---

pany. In the case study, the current approach of the case study company is compared to that of using forecasts based on POS data with dynamic lot sizing. The goal is to give an example of how our suggested approach can be applied through a real-world example.

**Objective 3:** Create guidelines explaining how manufacturers can use dynamic lot sizing based on forecasts of point of sales data for new product launches.

Our final objective is to create guidelines explaining the actions required by a manufacturer to implement the proposed solution used in the case study. To answer this objective we will combine the theoretical knowledge acquired in the literature study with the practical knowledge obtained in the case study. The final output will be guidelines that can be followed by manufacturers in order to perform dynamic lot sizing using forecasts based on POS data suited for the characteristics of the given company.

## 1.4 Research scope

The research scope will be limited to new product launches. According to the literature, manufacturers find it particularly challenging to estimate demand for new product launches, and analysis of point of sales data is most beneficial for products with a demand that is difficult to predict (R.M. van Steenbergen, 2020; Kahn, 2014). Additionally, Olsen (2021) conducted research on the same company used in the case study of this master's thesis, Brynild, using the same data foundation as in this master's thesis, and argued for that downstream information sharing of supply chain data is most beneficial for new products. In our research, the use of downstream supply chain data will be limited to point of sales data from the grocery stores. Our assumption is that utilization of POS data will yield the biggest benefits for food manufacturers.

In this master's thesis we investigate the use of point of sales data in short-term demand forecasting to facilitate dynamic lot sizing. We apply forecasting methods that are highly regarded in the literature, however, the aim is not to develop a new forecasting method beating the existing state of the art time-series forecasting methods. Similarly, we apply a dynamic lot sizing model, but we do not attempt to create an improved lot sizing model. Instead, our research examines the utilization of forecasts based on POS data in a dynamic lot sizing model to facilitate dynamic lot sizing of new products for food manufacturers.

---

As we only examine new product launches we are required to determine the length of the launch period, meaning the number of days after product launch where the product can be considered new. Some studies suggests that the launch period can range from 2-12 months depending on the characteristics of the products sold (Schoenherr and Swink, 2015; Soni and Cohen, 2004). In our previous work with the case company, Brynild, the length of the launch period was set as the average number of days it took for the demand to stabilize (Flaarønning and Løvhaugen, 2021). The time it took for the products demand to stabilize was on average about 6 months. In this study we have chosen the same length of the launch period, meaning we will only investigate improving forecasting and production planning during the first 182 days after the product's launch date.

## 1.5 Report outline

The motivation and problem formulation has been presented in this chapter, resulting in a research question with three research objectives and a clear research scope. The next chapter presents the research methodology used to answer the research question in addition to justifications for the selected methods. Following is the "Theoretical Background" chapter, presenting relevant theory on Manufacturing Planning and Control, lot sizing, demand forecasting, and information sharing based on literature study findings. Further, the chapter "Empirical Background" describes the Norwegian food supply chain, including its characteristics, common methods of demand forecasting, and the current state of information sharing within the supply chain. In the chapter "Case Study", the case company Brynild and its supply chain are presented. Additionally, the chapter explains the details regarding the quantitative analysis and model development performed during the research. Afterwards, the case study results are presented followed by a discussion of the findings. Next is the "Discussion" chapter where we discuss the findings in relation to the research question, and argue for the usefulness of the methods used in our research for manufacturers in general. The emphasis lies on interpretation of the findings, limitations and weaknesses of the study, and potential for further research. Finally, the last chapter presents the conclusion drawn from the conducted research.

---

# Chapter 2

## Methodology

The research methodology for the master's thesis is presented in this chapter. Kothari (2004) defines *research methodology* as a methodical approach to solving a research problem, and research methods as the tools researchers employ to conduct research. Furthermore, an essential part of the research methodology involves explaining how and why the selected methods are employed to address the research topic (Kothari, 2004). Based on the characteristics of the methods, qualitative and quantitative research methods can be distinguished. Quantitative methods focus on analyzing numerical data with the use of mathematical and statistical tools (Croom, 2008). Qualitative methods use non-numerical data for understanding concepts and experiences with perception, interpretation, and constructivism (Croom, 2008). A literature review and a case study are chosen as research methods to answer the research question stated in Section 1.3. The following sections will present the methods and the justification for why they are selected, establishing the research methodology.

### 2.1 Literature study

A literature study was selected as a research method. According to Croom (2008), a *literature study* is used to get an overview of the current research on relevant topics and a deep understanding of state-of-the-art solutions. It is a fundamental part of research to make sure that the research is contributory (Snyder, 2019). Further, the literature study helps to narrow the scope of the research to focus on the existing research gap (Karlsson, 2010).

Therefore, the literature study was carried out to gain insights into previous literature on relevant topics and to identify a research opportunity. More specifically, a

---

literature study was required for this research in order to acquire insight into food supply chains and challenges regarding new product launches. The literature study used to get knowledge on production planning and control in order to understand the case company, their data, and the challenges they face. Further, research on lot sizing problems and forecasting methods was necessary to study in order to understand current solutions and to apply them in the case study. In addition, the most recent research on information sharing and utilization of point of sales data was examined to determine the state-of-the-art. The literature study is therefore used to answer research objective 1, to develop the research within the case study, and form the theoretical foundation for research objective 3.

The first step in the literature study process was to find relevant research papers and articles relevant to our research. Initially, a random search approach was used, not relying on scientific research databases. Instead, Google Search was utilized to capture the overall picture of the food industry, including essential actors, common practices, and challenges. Additionally, we were recommended certain publications from people who have conducted research on similar topics within the Norwegian food supply chain at the institute. Simultaneously, several academic textbooks on operation management and production planning were used to acquire knowledge on these topics.

With a broader understanding of the research topic, building block search was the following search strategy used. The initial step resulted in a list containing terms and phrases commonly used in the food supply chain, production planning, forecasting, and information sharing. The terms and phrases from the list were then joined with boolean operators into blocks and used to search in academic databases, mainly Scopus, Google Scholar, and Oria. The block searches resulted in a significant number of papers. The title and keywords were the first to be reviewed in order to filter out irrelevant articles from the large number of total papers. Secondly, the abstract and conclusion were read to ensure the article's relevance further. Simultaneously, as the papers were checked for relevance, the articles were assessed for quality to ensure that the research was reliable. In order to determine the quality of the paper, the authors, publisher, amount of citations, time since publication, language, and peer-reviewing were examined. The number of citations was weighted less if the paper was recently written, as the paper could still have adequate quality (Croom, 2008). The article was skimmed or read in its entirety, and a short review was produced if the article seemed relevant and passed the initial quality evaluation.

Additionally, during the building block search, cited reference search and citation search strategies were utilized to find similar papers of relevant articles. The two

---

search strategies involve examining the papers referencing or citing the selected article. These methods effectively find relevant papers that might have used different terminologies or approaches. Furthermore, because cited papers are older and citing publications are newer, combining them can indicate how the research has evolved through time. These papers were also reviewed, and quality checked as described above. Moreover, new topics or terms acquired from these articles further updated the building blocks search, making the process iterative.

## 2.2 Case study

Yin (2009) describes the *case study* research method as the following: "... the case study is used in many situations, to contribute to our knowledge of individual, group, organizational, social, political and related phenomena". According to Voss et al. (2002), the case study is a frequently used method within operations management that has provided important research using data from case companies. A case study can use both qualitative and quantitative data to conduct theory but also test it in practice (Croom, 2008). Understanding the phenomenon studied should be the goal of the case study, in addition to support validation of the case results (Meredith, 1998).

To answer the research question in this master's thesis, a case study of Brynild was conducted, utilizing both quantitative and qualitative data. The case study was done to develop and test the theory with actual data from a real company as it provides rich and detailed data. Research objective 2 is directly answered from the case study. In addition, the case study provides practical insights into answering research objective 3.

Data from the case company Brynild was captured and collected in multiple ways, including both quantitative and qualitative data. It should be noted that this master's thesis is a continuation of the specialization project of Flaarønning and Løvhaugen (2021). Flaarønning and Løvhaugen (2021) conducted a case study of Brynild with the same data foundation used in this master's thesis. Therefore, some of the data collection presented bellow will be the same.

### 2.2.1 Qualitative data collection

Qualitative data has been collected to understand the production planning and control system at Brynild. In addition, the qualitative data were gathered to provide

---

a better insight into the Norwegian food supply chain. The qualitative data has been necessary to ensure that the research is relevant for the case company and the industry in general. Furthermore, the qualitative data is used to make assumptions and set boundaries for the quantitative analysis. The qualitative data were collected in the following ways:

### **Physical and digital meetings**

Multiple digital meetings with Brynild were held over the fall of 2021. The participants were mainly Haris Jasarevic (Project Manager Digitization/Automation Factory) and Mathias Holm (Supply Chain Director). Digital meetings with Eirik Blå (Senior Production Planner) and a physical meeting at NTNU with Mathias Holm (Supply Chain Director) were held during the spring of 2022. From these meetings, qualitative data on the case company and relevant aspects of the research was provided. The participants shared information on the research topic from their point of view in addition to insights on Brynild. These meetings can be classified as informal interviews as they did not follow a specific structure with an interview protocol. Notes were taken from each meeting and used as a reference for later. Discussion about what quantitative data Brynild had available was the main topic in several meetings. Through these meetings, we mapped what data Brynild had collected from the supply chain over the past years and how complementary the data was for each participant in the supply chain. This was an essential part of the research to make sure that the data collected was able to provide us with insights into the research topic. In addition, we were informed about how Brynild has used this data to date.

### **Emails**

Furthermore, several email exchanges with Brynild took place during the fall of 2021 and spring of 2022, where supplementary questions, clarifications, and assumptions were discussed. The emails were mostly exchanged with Mathias Holm (Supply Chain Director), but some also with Haris Jasarevic (Project Manager Digitization/Automation Factory) and Eirik Blå (Senior Production Planner).

### **Company visit**

A company visit to Brynild was done on 29.10.2021 to better understand the planning and production processes of Brynild. At the factory, we got a tour where the



---

sugar and nuts production was shown and explained in detail. In addition to the tour, we had meetings with Haris Jasarevic (Project Manager Digitization/Automation Factory) and Mathias Holm (Supply Chain Director) to discuss the use of point of sales data and what data was available. During this meeting, Elisabeth Tegneby (Key Account/Business manager) held a short presentation on how Brynild previously had used point of sales data when a new variety of nuts were released in 2020.

## Documents

Documents have been collected and studied to gain knowledge about the case company Brynild. A presentation about Brynild in the course TPK4100 - Operations Management at NTNU has been used to gain a general understanding of the company. Additionally, the document "As-is planning and control of sugar molding at Brynild", a short-term project between NTNU and Brynild, was used to understand Brynild's way of performing production planning and control.

### 2.2.2 Quantitative data collection

The quantitative data collection was done with the help of Haris Jasarevic (Project Manager Digitization/Automation Factory) on two occasions. Haris first supplied us with data of Brynild's customers, products, and sales. He also provided data from the Tradesolution platform, containing information about NorgesGruppen stores and sales from ASKO to the stores of NorgesGruppen. In addition, Haris shared point of sales data Brynild had acquired from NorgesGruppen. This data was received by a SharePoint link sent in an email on October 29th 2021, and also used in the work of Flaarønning and Løvhaugen (2021). Then, on March 31th, Haris granted us access to Brynild's production data, as well as customer orders and sales history, through a SharePoint link. The same day, Eirik Blå (Senior Production Planner) sent us an email containing a file with production information for sugar products.

Tables 2.1, 2.2 and 2.3 shows an overview of the quantitative data collected from Brynild's supply chain. The tables show the dataset received, the number of rows and columns in the dataset, and a short description of what the dataset contains. As can be seen from the tables, a huge amount of data was collected. Dataset 6\*, 7\*, and 8\* were collected during the spring of 2022, while the rest was acquired in the work of Flaarønning and Løvhaugen (2021).

---

Dataset	# rows	# columns	Description
1	7963	11	Brynild's customers
2	10636	35	Detailed data on Brynild's customers
3	8580	92	Brynild's products
4	454622	20	Brynild's sales to wholesalers from 2013-2021
5	553672	21	Brynild's sales to wholesalers for all sale solutions from 2013-2021
6*	217057	11	Brynild's production output from 2015-2021
7*	185518	10	Orders and deliveries to all of Brynild's customers from 2016-2022
8*	27	40	Production information of sugar products

Table 2.1: Data from Brynild

Dataset	# rows	# columns	Description
9	18	3	NorgesGruppen's store profiles
10	5071	38	NorgesGruppen's stores
11	10967804	13	Sales from ASKO to NorgesGruppen stores for all sale solutions
12	10631098	22	Sales from ASKO to NorgesGruppen stores

Table 2.2: Data from Tradesolution

Dataset	# rows	# columns	Description
13	19649364	7	Inventory level for Brynild's products at NorgesGruppen stores from 2015-2020
14	45188348	8	Point of sales for Brynild's products in NorgesGruppen stores from 2015-2020

Table 2.3: Data from NorgesGruppen

### 2.2.3 Validation of case data

The data from Brynild, shown in Table 2.1, is data that Brynild has gathered and stored by themselves, either manually or from the ERP system. Brynild always has access to this data, and other manufacturers usually have similar data. However,

---

historical data on forecasts and forecast accuracy was not able to be acquired in the case study. Additionally, the production data only displayed the output for finished products and not intermediates.

The data from Tradesolution, shown in Table 2.2, is gathered by Brynild through the Tradesolution platform. Tradesolution is a company that is owned by the major actors in grocery retail in Norway, like NorgesGruppen, COOP, REMA 1000, in addition to an interest organization called Dagligvareleverandørens Forening (*DLF*, n.d.). Tradesolution maintains the electronic product database where all products sold in Norwegian grocery stores must be registered (Dulsrud and Alfnes, 2015). Furthermore, Tradesolution stores information on retail stores and sales from wholesalers to retailers (*Tradesolution*, n.d.). Data from Tradesolution should therefore be accessible for Brynild in the future and for other food manufacturers in Norway.

The point of sales data represented in Table 2.3 is acquired by Brynild from NorgesGruppen. The reason NorgesGruppen shared the point of sales data with Brynild was mainly for research purposes through a shared research project, Digimat. Although, NorgesGruppen also shared point of sales data with Brynild when "pick and mix" nuts were replaced by new prefilled cups of nuts in 2020. Only POS data from NorgesGruppen was collected for this master's thesis and gave information for only one of Brynild's primary customers. At the time of collection, Brynild stated that they had purchased POS data from REMA 1000, but the data was not ready for usage yet. The POS data of REMA 1000 is stored at Tradesolution. Furthermore, Brynild had limited access to POS data from COOP, mainly downloads from a business intelligence system. Accordingly, Brynild does not have access to POS data from all retail chains on a regular basis. However, as can be seen for Brynild, there has been a development with increased sharing of supply chain data. Brynild and other manufacturers within the food supply chain may have POS data available if the development continues, at least for some customers.

## 2.2.4 Quantitative data analysis

All the data collected was received as either Excel files or CSV files. To be able to use the data effectively, the first step of the analysis was creating an SQL database with SQLite3 (Hipp, 2020). The database was created by inserting each Excel or CSV file into the database.

The analysis was performed using the programming language Python in Google Colaboratory, allowing the Python code to be run in the cloud (Van Rossum and Drake,

---

2009; *Google Colab*, n.d.). Data from the SQLite3 database was extracted by SQL queries and stored in Pandas dataframes, a Python data analysis and manipulation tool (Pandas, 2020). The data was cleaned and transformed, and some data had to be calculated from other data. The main part of the case study was the model development which is elaborated in detail in section 5.4. The forecasting methods have been implemented with Statsmodels and Tensorflow (Abadi et al., 2015; Seabold and Perktold, 2010). The lot sizing models were developed with Gurobi and solved with the Gurobi Optimizer, a mathematical optimization solver (Gurobi Optimization, LLC, 2022). Some of the results in the case study are visualized as graphs with Plotly, an open source graphing library for Python (Inc., 2015).

## 2.3 Research overview

An overview of the conducted research is illustrated in Figure 2.1. The literature study was used to answer the research question directly but was also necessary to develop the quantitative data analysis of the case study. The case study answered the research question through both qualitative and quantitative data collection in addition to analysis of the quantitative data. Qualitative data collection was essential to guide the quantitative data analysis with data from the case company.

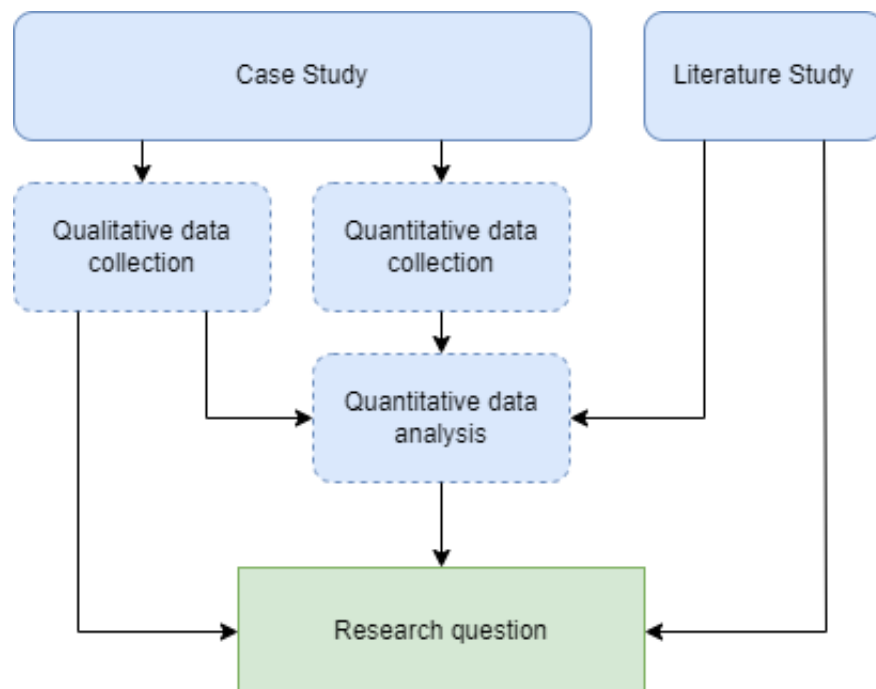

Figure 2.1: Overview of the research

---

# Chapter 3

## Theoretical Background

This chapter presents the theoretical background based on the literature study. Manufacturing planning and control is first introduced, before lot sizing is further elaborated. Then theory on demand forecasting is presented, followed by a section on information sharing in supply chains.

### 3.1 Manufacturing Planning and Control

#### 3.1.1 Introduction and overview

Jacobs et al. (2011) describes manufacturing planning and control (MPC) as a system that is concerned with planning and controlling all aspects of manufacturing. The authors further describe that this includes managing material, scheduling machines and people in addition to coordinating suppliers and key customers. An essential part of the MPC system is that the activities develop over time due to market and strategy changes. Effectively responding to the changes is a key to succeed in any production company, according to Jacobs et al. (2011). MPC is also referred to as production planning and control (PPC) and will be used interchangeably. According to Slack et al. (2019), PPC is concerned with: "... the activities that attempt to reconcile the demands of the market and the ability of the operation's resources to deliver. It provides the systems, procedures, and decisions which bring different aspects of supply and demand together". Manufacturing planning and control is a way to manage resources to meet the demand, which is especially needed with increasingly higher customer demand and expectations in a competitive climate (Stevenson et al., 2005). Typical functions within MPC are planning

material requirements, demand management, capacity planning, and the scheduling and sequencing of jobs (Stevenson et al., 2005).

This chapter introduces theory on MPC based on the manufacturing planning and control system framework developed by Jacobs et al. (2011). Figure 3.1 shows a simplified overview of the MPC system. The figure shows that the MPC system can be divided into three phases. Moreover, the figure displays the use of enterprise resource planning (ERP) systems in all parts, which are typically used in an MPC system today. This paper will focus on the long term and medium term of the MPC system.

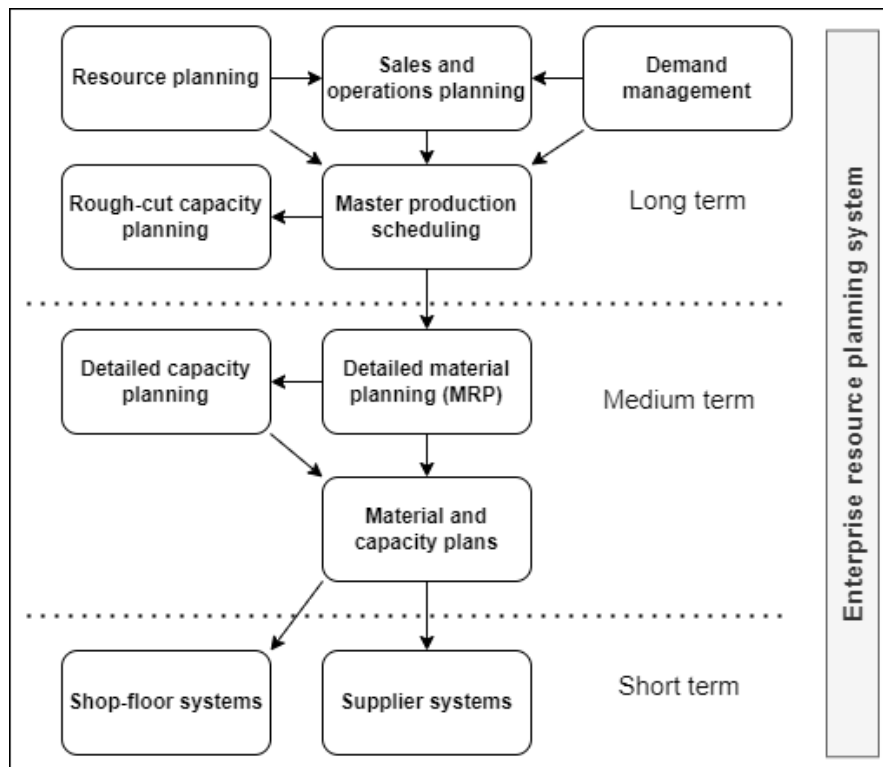

Figure 3.1: Manufacturing Planning and Control System. The figure is collected from Jacobs et al. (2011).

### 3.1.2 Planning and Control

Planning and control are an essential part of MPC, and it is important to understand the differences between them. Slack et al. (2019) defines planning as formalizing what is going to happen in the future. Within production, planning is the overall decisions that are made on how to use current resources, determine the future resources needed, and acquire new resources (Sanders, 2012). As all information about the future is not available in the present, the plans are driven by a forecast.

---

Planning is the process of choosing the right actions based on a forecast (Sanders, 2012).

Control is cornered with monitoring and handling deviations from the initial plans (Slack et al., 2019). Plans are based on forecasts and assumptions that can change throughout the planning period. Assumptions can be machine up time, order delivery from suppliers, and available resources like capital. Therefore, control is needed so the producer can react and make changes if forecast accuracy is low or the assumptions are wrong. In fact, Nahmias and Cheng (2009) argues that forecasts usually are wrong, showing the great need for control when the plans are based on forecasts. Disruptions can always happen in a supply chain, so there are no guarantees that the plans will be successful. However, better plans can be made with more intelligent and accurate forecasts (Jacobs et al., 2011). According to Sanders (2012) the time from awareness of an unforeseen impending event until the need to make a response has become shorter over the last years, emphasizing that forecasting, planning, and control are even more critical today.

Planning and control are complementary tasks that are very related. The time horizon is the key factor in deciding their balance. The planning and control activities can be organized hierarchically based on the time until the event that is being planned for (Bonney, 2000). Slack et al. (2019) and Jacobs et al. (2011) categorize the activities of planning and control by long-term, medium-term and short-term. Figure 3.2 shows the significance of planning and control and how they change over a time horizon. In the long-term, planning is the most important, but the need for control increases closer to the end of the planning horizon (Slack et al., 2019).

The MPC system in the long-term considers strategic decisions on what to make, what resources the company need, and what objectives the company want to achieve (Slack et al., 2019). These plans are less detailed, focusing on volume estimations and financial targets, and there is little use of control principles. Moreover, in the long-term, the MPC system should provide information on the overall capacity and resources needed to evaluate if the market's future demand can be met with the current capacity (Jacobs et al., 2011). Aggregated forecasted demand is often used to determine aggregated resource requirements.

The planning gets more detailed in the medium-term perspective, where in addition to the product volume, the product mix is of focus (Jacobs et al., 2011). The forecasted demand gets more disaggregated to match the supply with the demand in terms of both volume and mix. Therefore, the focal point is to provide the exact production materials and the required capacity so customer needs can be met.

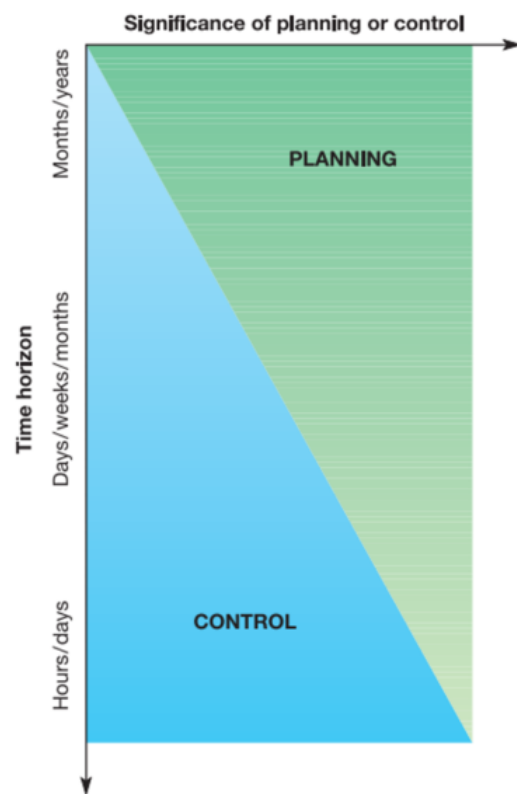

Figure 3.2: Significance of planning and control over different time horizons. The figure is collected from Slack et al. (2019).



---

Jacobs et al. (2011) further elaborates that the right level of raw material, work in progress, and inventory of finished goods and their timing is essential. In the medium-term, deviations from the plans can occur, and reserve resources can be built up to control the variations to make the planning and control in the short-term easier (Slack et al., 2019). As a result, the planning and control are more balanced in this stage.

In the short term, it is harder to make significant changes as the extent of resources has already been planned for (Slack et al., 2019). On the other hand, detailed scheduling of the available resources like time, material, and equipment is required to face the production requirements (Jacobs et al., 2011). The forecasted demand is here totally disaggregated, or the actual orders are used if available. It is essential to measure the manufacturing performance and use of resources to control the execution of the plans (Jacobs et al., 2011). The information must be shared between managers, customers, and suppliers as changes can happen rapidly. Thus, PPC is more focused on controlling rather than planning in the short term.

### **3.1.3 Product process types and production environments**

The manufacturing planning and control system is often designed based on factors like the volume and variety of the production output and the influence customers can have on the final products (Chapman, 2006). Olhager and Wikner (2000) states that it is necessary to understand the environment in terms of customers, markets, and production processes to organize an efficient MPC system. In this section, product process types that correlate with volume-variety characteristics are briefly introduced before production environments are explained.

#### **Project process**

In a project process, the output is often a one-of-a-kind product (Chapman, 2006). The product is highly customized, and the product takes a long time to finish as the process is complex (Slack et al., 2019). The project process has typically very low volume and wide variety (Slack et al., 2019).

#### **Job shop process**

Job shop processes are usually flexible where the equipment is general and can be used for multiple purposes (Chapman, 2006). The workers tend to be highly skilled

---

in producing customer-specific products. The product variety is therefore wide, and the volume is low (Slack et al., 2019). Job shop processes can be complex, and each product shares resources with other products (Slack et al., 2019).

### **Batch process**

The batch process produces multiple products within a period and is one of the most common processes in the world today (Chapman, 2006). Batch processing can produce several items during a period before the setup is changed and another batch of a similar product is made. As a consequence, the product volume and variety in a batch process can differ widely (Slack et al., 2019). The equipment is often more specialized compared to a job shop process and requires a less skilled workforce (Chapman, 2006). However, similar worker skills and machines are often grouped together, making the product move through different specified areas during the process. A batch process can be quite similar to a job shop process, especially if the batch size is small, but the variety is lower in the batch process (Slack et al., 2019).

### **Repetitive flow process**

The repetitive flow process produces products in high volume with a narrow variety, usually highly standardized products (Slack et al., 2019). This type of process is sometimes referred to as a mass process. The equipment is often specialized and requires little labor, making the fixed cost lower due to the high volume (Chapman, 2006). As a result, the product price is often low and competitive.

### **Continuous flow process**

A continuous flow process is on the far end of production processes types where specialized equipment and a low labor force are needed (Chapman, 2006). The product volume is very high with very low variety, and the products are produced in an endless flow (Slack et al., 2019).

Figure 3.3 summarizes the manufacturing process and the volume-variety characteristics. The five process types introduced here are the most common but note that there can be hybrid processes that combine these common processes (Chapman, 2006). This could be the case in the food industry, where some products are

produced in a repetitive flow process before the packaging is done in a batch process.

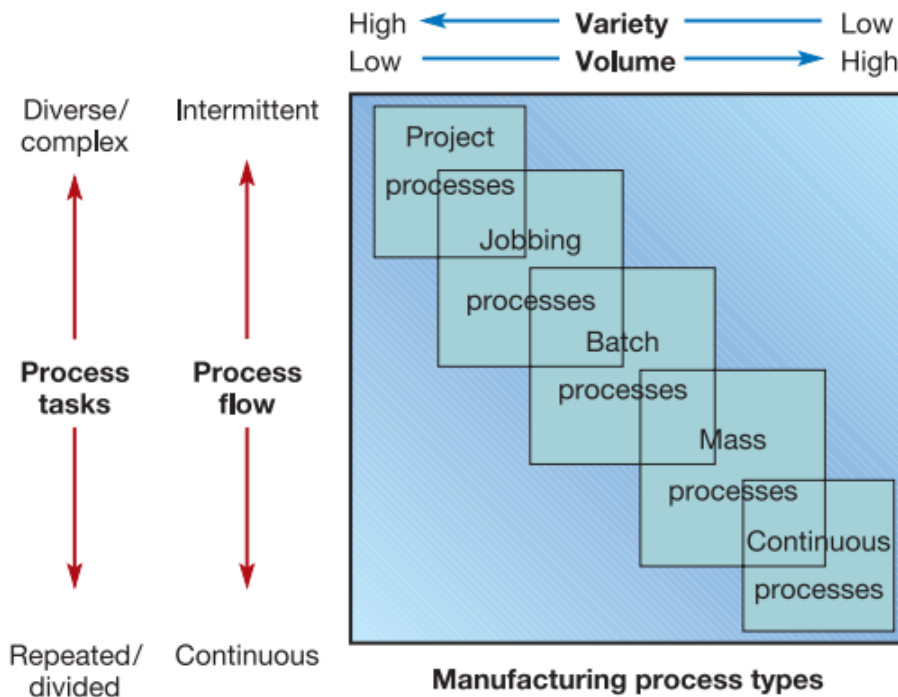

Figure 3.3: Different process types imply different volume–variety characteristics for the process. The figure is collected from Slack et al. (2019).

In addition to the process type, the production environment highly dictates the planning and control needed for a company (Chapman, 2006). The production environment can be classified by where the Customer Order Decoupling Point is located (Jacobs et al., 2011). Olhager (2003) defines the Customer Order Decoupling Point (CODP) as the location of where a specific customer order interacts with the value chain to the manufacturer of the product. The CODP shows how much the customer can influence the final design of the product (Chapman, 2006). As a result, production that is happening before the CODP is based on forecasts and plans, while customer orders are used in the production after the CODP. Therefore, the CODP is the point where the demand changes from independent to dependent (Jacobs et al., 2011). In some cases, the term Order Penetration Point is used. With the use of the CODP, Olhager (2003) and Jacobs et al. (2011) have defined four production environment as shown in Figure 3.4. Make-to-Stock will be presented here as the is most common environment within food manufacturing.

### Make-to-Stock

Jacobs et al. (2011) describes the *make-to-stock* (MTS) environment as an environment where the CODP is located in the finished goods inventory. The products are

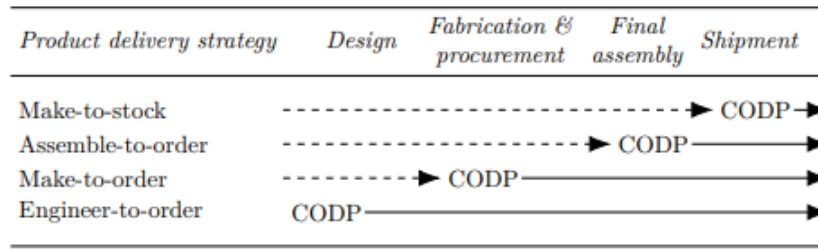

Figure 3.4: CODP for production environments. The dotted lines depict the forecast-driven production activities, whereas the straight lines depict customer-order-driven activities. The figure is collected from Olhager (2003).

completely made and stocked in a finished goods inventory. Customers only consider whether or not to buy the product, and the service level relies on whether the product is in stock or not. The production plans are entirely based on forecasted demand. Therefore, the plans must include in what quantity and at what time the finished goods inventory stock is replenished. Demand management in an MTS environment is focused on the finished goods inventory and the activities connected to replenishing the stock. Chapman (2006) describes the primary focus in an MTS environment to be forecasting, inventory, and safety stock policies. The challenge is to balance inventory and customer service levels. As to say, there is a trade-off between increasing inventory cost and service level. Since the manufacturing plans are based on forecasted demand, the forecast accuracy should be monitored so corrective actions can be made in time. A more optimal trade-off can be made with more accurate forecasts and insights on customer demand.

Additionally, many MTS companies use multiple warehouses and distribution centers to accomplish the desired service level. The forecasting and master scheduling is commonly done at the finished item level, where the master production schedule can be seen as the inventory replenishment schedule (Chapman, 2006). He further states that the most common methods to influence demand are pricing, advertising, and promotions. The communication with the customer is often shallow, except for cases with back-ordering. The customer receives the products within a short period, primarily instantaneously. Batch, repetitive flow, and continuous flow process are mainly present in an MTS environment Chapman (2006). The MTS production environment is very commonly used within the food production industry.

### 3.1.4 Demand Management

There is a need for managing demand as most markets are changing over time. *Demand management* is concerned with activities like estimating the demand, con-

---

verting customer orders to delivery dates, and balancing supply and demand (Jacobs et al., 2011). The customers and the market is in focus where information to consider demand management is gathered through demand planning, customer orders, and product requirements (Jacobs et al., 2011). Chapman (2006) explains four major aspects of demand management presented here.

The first aspect is *prediction*, where forecasting the customer demand is essential. Forecasts are not always correct, and demand management is needed to anticipate how correct the forecasts are and how the incorrect information is handled. Jacobs et al. (2011) argue that this is one of the reasons there is a clear distinction between forecasts and plans. The authors explain that forecasts are estimates, and the plans are made on these estimates. Further, plans and forecasts can differ depending on multiple factors. Nevertheless, the plans based on the forecasts are fully controlled, whereas the demand is not. The MPC system should provide plans that are executable with clear instructions. Furthermore, the control function should make new plans when conditions within the system change. Uncertainty in demand makes MPC and demand management more complex, and inaccuracies in the forecasts can lead to excess inventories or lost sales (Lawrence et al., 2000; Slack et al., 2019) . However, Chapman (2006) presents the following methods of coping with uncertainties in the demand and forecast errors.

1. **Communication.** More communication with the customers to be able to understand the demand patterns faster and more accurately.
2. **Influence.** If forecasts and available resources differ, there is a decision to be made whether to change the resources or to use marketing tools to influence the demand.
3. **Lead time reduction.** The further into the future the forecast is made for, the more inaccurate it will be. With a lead time reduction, the forecasting error and the need for further demand management can be reduced.
4. **Production flexibility.** With high production flexibility, the unexpected demand can be more rapidly met with production changes. This method is closely connected to lead time reduction, as the process setup influences both.
5. **S&OP and the master schedule.** The sales and operations plan(S&OP) and the master production schedule (MPS) are higher-level plans that are often made with the desired customer service level, inventory policy, and more in mind. These plans can greatly impact the ability to handle unexpected demand.

- 
6. **Safety stock or MPS overplanning.** With a safety stock or MPS overplanning, the forecasted errors can be reduced when the forecasted quantity is too low. However, if the forecasted quantity is too high, there is a risk of overproduction and obsolescence of products.

*Communication* is the second aspect of demand management. Good communication with customers is especially important. The communication can be order entries, order delivery promises, or customer service.

The third major aspect of demand management is *influence* and is one of the key tasks of the sales and marketing department. When a forecast of future customer demand has resulted in a plan, the company can decide to influence the demand to better utilize resources within the company and to better match supply with demand. Companies can influence the demand for their products in various ways. With campaigns, advertisements, price changes, and more, the customer's behavior and perception of the products can be changed (Sanders, 2012). Demand management can have an impact on production plans, and as a result, the plans need controlling accordingly (Sanders, 2012). However, when influencing the demand, the sales and marketing department should have a close connection to the production department, so opportunities and constraints are understood (Chapman, 2006).

*Prioritization and allocation* is the last major aspect presented by Chapman (2006). New orders that are entered should be prioritized according to all other orders, and this is often done continually where resources are allocated accordingly. Clear guidelines and rules should be present to ensure that the resources and priorities are best suited for the company.

Chapman (2006) further describes two important reasons why demand management is crucial for planning and control. The first reason is that some demand comes from internal sources. The second is that marketing and sales are more flexible and can change plans faster than production plans can be changed. The first reason is also explained by Jacobs et al. (2011), where they also argue why the distinction between forecasts and plans is essential. The demand patterns and the company's response to the demand can be quite different. The decision to buy a product lies with the customer, independent of each separate customer. The aggregated demand for a product is made up of multiple customers and is hence independent to the company (Waters, 2008). The company can influence the decision with demand management, but the customer's demand is independent. The independent demand thus needs planning and control for forecasting and responding if the forecast is not matched (Slack et al., 2019). On the other hand, parts for planned products are said to be

---

dependent, and the amount can be calculated with relative certainty (Slack et al., 2019). Similarly, products with known customer orders are perceived as dependent demand. To determine the demand from all sources is also an essential part of demand management, where the demand can come from inventory build-up for promotions, spare parts, new products, and inventory changes (Jacobs et al., 2011). Considering all this demand is necessary to create realistic manufacturing planning and control plans.

### 3.1.5 Sales and Operations Planning

*Sales and Operations Planning* (S&OP) is focused on creating low detailed plans that align resources with strategical plans of the company (Chapman, 2006). This requires coordination of several fundamental functions within the company like operations, marketing, financial, and human resources, which can be a challenging task (Grimson and Pyke, 2007). An example is releasing a new product in the market, where manufacturing capacity, promotional marketing plans, financial resources, and capital need coordination so pipeline inventory can be built up. As a result, planning of inventory levels, cash flow, human resources, production outputs, capacity planning, and sales and marketing activities are decisions that need to be established in S&OP (Chapman, 2006).

The key objectives are to create a sales plan and an operations (production/manufacturing) plan that represents management's handle on the business (Jacobs et al., 2011). The length of S&OP plans depends on how long time the company needs to secure resources if estimates show that it is needed, which often is months or years (Chapman, 2006). Jacobs et al. (2011) further states that within manufacturing planning and control, S&OP is likely the least understood aspect, but the benefits of a good S&OP plan are significant. Tavares Thomé et al. (2012) states that S&OP has two purposes, firstly balancing the supply and demand, and secondly, linking operational plans and strategic plans. The role of S&OP is to have a process that creates a balance between demand and supply, in addition, to giving early warnings when they differ (Jacobs et al., 2011). According to Olhager et al. (2001), at the S&OP level, the production plan is based on the sales plan, which again is based on forecasted demand. The authors further explain that any differences between the operations and sales plans will result in a complementary inventory or backlog plan. It will be an inventory plan in an MTS environment and a backlog plan for an MTO environment. The operations plan can differ from the forecast of aggregated demand, as the operations plan is planned production based on strategic decisions

---

(Jacobs et al., 2011).

Another fundamental part of S&OP is the volume and mix of products, which has to be treated differently in the MPC system (Jacobs et al., 2011). Volume means how much to produce, and it considers production rates within product families usually stated in aggregated units. The product mix focuses on more detailed decisions for individual products, like what quantity to make and the sequence. However, Olhager and Rudberg (2002) explains S&OP as mostly volume planning. Jacobs et al. (2011) explain that S&OP is focusing on the big picture, which is matching supply and demand in terms of volume before details of MPC are considered. The mix will then be easier to manage when the volume is planned effectively. Chapman (2006) explains that the aggregation in the volume is essential because forecasts are usually more accurate in terms of aggregation. It is further discussed about the aggregation of time in buckets (weeks, months, or years) and the level of detail in the planning. Aggregation should be done to the degree that allows for easier planning of resources without losing valuable information.

A sales and operations planning process can be divided into five steps (Grimson and Pyke, 2007). The process involves considering changes in the sales plan, operations plan, and the inventory (Jacobs et al., 2011). The five steps could be done monthly where Jacobs et al. (2011) describes the steps as follows:

1. **Sales forecasting**
2. **Demand planning**
3. **Supply planning**
4. **Pre-SOP meeting.**
5. **Executive SOP Meeting**

### **3.1.6 Master Production Schedule**

The *master production scheduling* (MPS) system states what end products are going to be produced in addition to the quantity and timing of the production (Slack et al., 2019). Chapman (2006) explains that MPS is the next logical step after S&OP as the MPS uses the resources that were planned in S&OP. He elaborates further that the MPS is more detailed and planned in terms of end products for a shorter time horizon. The S&OP is, on the contrary, less detailed, often using product families over a longer horizon. The relationship is that the capacity constraints developed



---

in the S&OP work as boundaries in the MPS (Chapman, 2006). From S&OP, resources are planned based on aggregated forecasted demand, often without any customer orders. Therefore, MPS, in addition to using forecasted demand, uses actual customer orders when available (Chapman, 2006). All sources of demand should be included, like spare parts and internal promises. It is also worth noting that the demand forecast methods usually differ in S&OP and MPS. The demand forecasts in MPS are generally made from time series and qualitative methods, whereas casual methods often are used for the long-term aggregated forecasts in S&OP (Chapman, 2006). In addition to forecasted demand and actual orders, the MPS considers the cost of production and capacity limitations (Jacobs et al., 2011).

The MPS can be seen as a disaggregation of the S&OP, and more specific resource and capacity plans are thus needed. As a result, planning and utilization of equipment and labor are done with a base in the MPS (Slack et al., 2019). In an MTS environment, the MPS states the production quantity and timing of end products (Jacobs et al., 2011). The MPS can be seen as a final assembly schedule (FAS), working as a replenishment schedule of the finished goods inventory (Chapman, 2006). The master schedule makes use of the projected available balance to schedule the production (Jacobs et al., 2011). The projected available balance is calculated by adding the previous balance with the scheduled production quantity before subtracting the forecasted demand. The scheduled production quantity is called the lot size, and it represents the number of units made in a batch (Jacobs et al., 2011). Lot sizing decisions often involve a trade-off between inventory holding costs and setup costs (or order costs), making the quantity and timing of the production essential for minimizing the total costs (Chapman, 2006). Other factors like available storage and risk of obsolescence can influence the lot sizing decisions. Further theory on lot sizing is given in section 3.2, as it is a focal point in this master's thesis.

Many production approaches can be used to meet the demand. Chapman (2006) describes three common planning strategies that are used, namely level, chase, and a combination. With a *level* planning approach, resources are set to a level while the demand fluctuates. This approach gives a stable production environment, but building inventories are necessary if the demand cannot be influenced not to fluctuate. With the second approach, *chase*, resources are continuously changed to meet the fluctuating demand. A chase strategy is used if the demand is hard to influence and the resources are easily changeable. The chase strategy is often used with low volume and highly customized products, whereas the level strategy is used for high volumes and standard products (Olhager and Selldin, 2007). The last strategy is *combination*, and a mix of level and chase is used. The combination is the most used approach so companies can alter demand and resources to maximize their per-

---

formance. Safety stocks are often used, especially with the level or combination strategies. The safety stock works as a buffer for the schedule against uncertainty in demand, like forecast errors and backlogging of orders (Jacobs et al., 2011).

Chapman (2006) describes two common time fences used in the MPS planning, the planning time fence, and the demand time fence. The planning time fence is the time horizon currently being planned for. In the demand time face, only customer orders are used in the MPS, often in the first weeks of the planning horizon, as it is believed that customer orders matter more than the forecast in the short term. An essential point in the MPS is that the planning horizon should be longer than the cumulative lead time for the products being scheduled (Chapman, 2006). According to Stevenson et al. (2014) is the time horizon typically six to eight weeks. If new information is acquired during the planning horizon, changes in the MPS might be required to improve performance (Jacobs et al., 2011). However, many changes can be costly and reduce productivity. On the other hand, increased inventory and poor service levels can result from too few changes in the MPS. Changes in the MPS can cause ripple effects as a change in the plan impacts many components of the products. This effect is called nervousness, and safety stocks can reduce the impact (Chapman, 2006). Furthermore, it is more challenging to make changes in the MPS in the demand fence, so it is often looked at as frozen. A frozen time horizon means that no changes are possible (Jacobs et al., 2011). The MPS is increasingly flexible to changes further ahead in the planning horizon.

Additionally, Chapman (2006) explains that the MPS is usually implemented with a rolling horizon, where the current period is deleted before a new period is added at the end of the planning horizon. This implies that the planning horizon always has the same length, and all new information should be incorporated when the period is rolled forward (Chapman, 2006). New information can include inventory status, updated forecasts, and customer orders. The material requirements planning system will be driven by the MPS after it has been developed (Yeung et al., 1998).

*Material requirements planning* (MRP) is an approach for detailed material planning with a time-phased (period-by-period) approach (Jacobs et al., 2011). The MRP system systematically calculates the required number of parts or materials and at what time they are needed (Slack et al., 2019). Jacobs et al. (2011) further explain that MRP is a fundamental and central concept with materials planning and control and is usually a starting point when developing an MPC system. Additionally, MRP is the link to what is actually produced in the MPC system, as overall production plans are translated into detailed individual steps.

---

The MRP record represents the status and plans for the items in a time-phased way (Jacobs et al., 2011). It is used for raw materials, components, and finished goods, making it an essential part of the MPC system. The MRP record is usually divided into time buckets that could be a day, a week, or longer, where the number of periods is called the planning horizon. Chapman (2006) presents the following information in a typical MRP record:

- **Gross requirements** show the quantity needed for an item at the beginning of the period. Value often comes from the MPS for a parent product.
- **Scheduled receipts** are a representation of orders that have been committed and are expected to be available during the period. It also describes the status of open orders for the item at the beginning of the period.
- **Projected available**, available inventory for the item at the end of the period.
- **Net requirement**, the quantity needed of the item after gross requirements and projected available are considered.
- **Planned order releases** represent planned orders at the beginning of the period where lot sizes and lead times are taken into account. This is the main output of the MRP, showing the quantity and timing of the production or purchasing.

The master production schedule (MPS), alongside a bill of materials (BOM) and inventory levels, are used as the primary input for detailed material planning with MRP (Jacobs et al., 2011). The BOM can be thought of as the information about the product structure and how it is put together as it shows what components and parts each product requires (Slack et al., 2019). The inventory levels are used to incorporate information about products in stock, sub-assemblies, and components, so the net requirements are calculated. Slack et al. (2019) explains that with the inputs, the master production schedule is exploded, calculating when and in what quantity the number of parts and sub-assemblies that are required. The calculations start at the parent level and “exploded” through the lower levels in the BOM, where the inventory for the parts is checked before calculating the next level. Jacobs et al. (2011) describes using the inventory and already committed orders as gross to net explosion, where only necessary requirements are calculated. The authors elaborate that gross to net explosion is the concept behind dependent demand, demand that can be calculated from the parent component and thus does not need forecasting.

---

To incorporate the timing of the parts required, lead times are used in a process called back-scheduling (Slack et al., 2019). Back-scheduling determines when different tasks/assemblies need to be executed to get the end product finished in time. This process requires a sound system with accurate data of lead times, BOM, and work in progress (WIP) so components are started at the right time (Jacobs et al., 2011). However, the back-scheduling process gives advantages like reduced WIP, storage of finished components, and commitment to raw materials. In fact, Jacobs et al. (2011) states that the back-scheduling and the explosion are the heart of MRP.

The time-phased MRP records allow for explicit timing, lot sizing, and safety stock (Jacobs et al., 2011). With uncertainties in operations, many companies use safety stocks to deal with the uncertainties. The MRP record can be used to plan for these safety stocks by increasing the gross requirements (Jacobs et al., 2011). As a result, the make-to-stock environment is a good fit for the MRP system (Chapman, 2006). Additionally, Jacobs et al. (2011) elaborates that lot sizing can be done with the time-phased records combined with supplementary data. Discrete lot sizes can be developed so net requirements are satisfied for one or more periods, reflecting the best strategy for the organization. Lot sizing is further discussed in section 3.2.

Although the MRP system is an effective method for creating detailed plans, it should be noted that the MRP system is extremely data dependent (Chapman, 2006). Accurate data is therefore essential. The MRP system is also a push system, where orders are planned and pushed out. As a consequence, the orders can be pushed to work centers before they are needed if unexpected problems occur like machine breakdowns and late supplier deliveries (Chapman, 2006).

The outputs of the MRP are raw material requirements and component parts needed for each period (Jacobs et al., 2011). Production planners are most involved with the MRP system output. The MRP output can further be used in detailed capacity planning, as the MRP explosion assumes adequate capacity (Chapman, 2006). Detailed capacity planning using MRP planned order releases is often conducted iteratively and is described later in this chapter.

Chapman (2006) also explains that the MRP output can be used to plan the overall activities in a company, and different systems for this have been developed over the years. Manufacturing resource planning (MRP II) is one of them and is a closed-loop MRP system where the MRP plans are adjusted to capacity and resource calculations. Further development and evolution of the MRP II have led to enterprise resource planning (ERP) systems and will be presented in the next section.

---

### 3.1.7 Enterprise Resource Planning

*Enterprise resource planning* can be defined as: "...a complete enterprise-wide business solution. The ERP system consists of software support modules such as: marketing and sales, field service, product design and development, production and inventory control, procurement, distribution, industrial facilities management, process design and development, manufacturing, quality, human resources, finance and accounting, and information services. Integration between the modules is stressed without the duplication of information." (Slack et al., 2019). The ERP system provides information that is used in managing the day-to-day execution where standard MPC functions are supported (Jacobs et al., 2011). This includes demand management, S&OP, MPS, MRP, inventory control, forecasting, and more. The idea behind the ERP system is that production plans and all other parts of the company should be connected to maximize customer service and other strategical goals (Chapman, 2006). Material requirement planning is often the system's core and provides managers with information to handle planning and control. Nevertheless, in addition to production planning and control, the ERP is used to manage the whole enterprise, giving the name to the system (Chapman, 2006). Decisions and databases from the entire company are integrated to support this, always available in the system and with real-time information updates (Slack et al., 2019). As an ERP system is a computer system, the development in information technology has given more power, functionality, and flexibility to ERP over the years (Chapman, 2006).

Jacobs et al. (2011) explains multiple benefits of ERP. The ERP system integrates the MPC process, making it more efficient. Real-time data supported by the ERP system can improve responsiveness to customer needs. Additionally, there are advantages of integrating processes and data in an information system. The accuracy of the information can be improved and eliminate redundant processes. Despite these benefits and the popularity of ERP systems, there are challenges to implementing the systems. Chapman (2006) describes the challenges, and one of them is that the flow of information needs to be effective and efficient so that the data generated in the system is accurate and available at the right time. Since the ERP system integrates many aspects of the company, each part has to be well developed to gain the benefits of the integration. Under the circumstances, companies tend to construct a thorough process analysis of the whole organization. During this, they often find themselves in need of reengineering or improvement of the processes to make them fit with the ERP implementation (Chapman, 2006).

---

### 3.1.8 Capacity planning and management

Capacity planning is an essential part of the MPC system. In fact, Jacobs et al. (2011) states that two main activities need to be coordinated in the MPC system: “... planning/control of material and planning/control of capacities”. It is essential that the capacity is planned, making a sufficient amount of capacity available, so the production plans are correctly executed (Chapman, 2006). Excess capacity can be a costly and unnecessary expense, although inadequate capacity can impact service levels, increase work in progress inventories and frustrate workers (Jacobs et al., 2011).

Chapman (2006) describes two main factors to consider within capacity planning, namely the capacity and the load. Capacity is often declared as the production output rate and measured as the output per unit of time. On the other hand, the load is the planned work for a process for a set period. Chapman further describes capacity planning as harmonizing the difference in available capacity and the required capacity needed to satisfy the load that represents customer orders. Planners have to alter the capacity or the load so the two fulfill each other. Adjusting the capacity is most common, but the load is often changed when the capacity is difficult to adjust.

Figure 3.5 outlines the capacity planning in the MPC system and how it is connected with other functions (Jacobs et al., 2011). The figure also shows how capacity planning can be divided into long-, medium- and short-range horizons. The different horizons have different attention to detail appropriate to matching the production planning (Chapman, 2006). As with the rest of the MPC system, the focus of this master’s thesis will be on the long and medium range. Correspondingly, resource planning connected with S&OP, rough-cut capacity planning linked to MPS, and detailed capacity planning connected to MRP will be presented. Figure 3.5 also shows how S&OP, MPS, and MRP systems are respectively linked with double-sided arrows to resource planning, rough cut capacity planning, and capacity requirements planning. The capacity planning system supports the managers in making the right choices, so the material plan and capacity plan correspond (Jacobs et al., 2011). If they do not correspond, the plans will be ineffective or not possible to realize.

#### **Resource planning**

*Resource planning* is closely connected to S&OP, and it is done over the most extended period, often months, quarters, or years (Jacobs et al., 2011). Data from

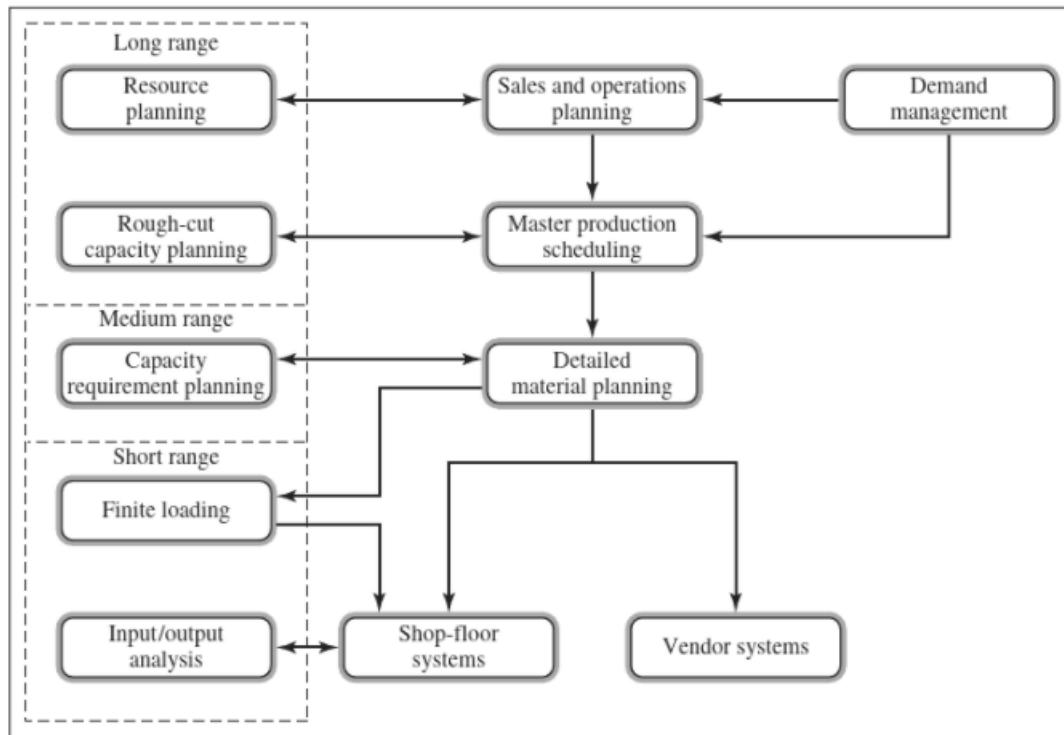

Figure 3.5: Capacity planning in the MPC system. The figure is collected from Jacobs et al. (2011).

the S&OP is used to create aggregated resource plans. The resources can involve machine hours, labor hours, and floor space where the capital, warehouse space, and machine tools need planning. Chapman (2006) describes two common options to achieve resource planning. One deals with the supply side, and the other takes care of the demand side. The supply option gives internal strategies that focus on operations to alter the production. It could involve changing the number of workers, using overtime, subcontracting, and increasing inventory. The demand option gives external strategies focused on the customer, trying to change the demand rate. The strategies could be pricing, promotions, advertising, and package deals. Chapman further states that the external strategies are commonly used with a level production approach while the internal is most used in a chase approach, where the inventory option might be the exception.

### **Rough cut capacity planning**

*Rough cut capacity planning* (RCCP) is connected to the master production schedule and uses information from the MPS (Jacobs et al., 2011). RCCP looks at known capacity bottlenecks to evaluate the capacity constraints on the medium to short term (Slack et al., 2019). Several techniques can be used to estimate the rough cut

---

capacity requirements of an MPS. They are rough and are often easy to calculate, which requires a tiny amount of data (Chapman, 2006). Some common methods are capacity planning using overall factors, capacity bills and resource profiles, but will not be elaborated here. A rough-cut capacity planning method should be selected regarding what level of details are needed and what information is available (Chapman, 2006).

### **Capacity requirements planning**

When a company uses material requirements planning (MRP) to create material plans with much detail, a detailed capacity plan can be made with *capacity requirements planning* (CRP) (Jacobs et al., 2011). Slack et al. (2019) explains that the MRP process needs to be checked to see if the plans are achievable, usually done in a closed-loop where production plans and available capacity are revised if needed. Capacity requirements plans consider orders from the MRP on a day-to-day basis (Slack et al., 2019). CRP uses the MRP as input where the bill of material (BOM), routing, and lead times of the lot sizes have been taken into account (Chapman, 2006). To increase the level of detail, work in progress, inventory levels, demand for spare parts, and expected scrap are also included in the CRP, ensuring that the capacity requirement timing is improved.

The detailed CRP can be challenging to manage effectively as the MRP constantly change when the material is used, received, or produced (Chapman, 2006). This causes the CRP to constantly change accordingly, which can be an issue for practical use.

### **Capacity management**

Capacity planning has been introduced as providing managers with data to support their decisions to manage the capacity. Chapman (2006) describes that the key in capacity management is to continuously compare the available capacity and the required capacity stated in the MPS and the MRP. When a mismatch emerges, changes in the material or capacity plan should be made, preferably the most cost-effective alternative (Jacobs et al., 2011). The capacity plan can be changed by hiring/-firing workers, increasing/decreasing machines, and allowing overtime/undertime. Similarly, the capacity requirements from the material plan can be changed. The options include subcontracting, substituting the raw material, changing inventories, and changing customer delivery promises. Notice that some of these options are



---

similar to those mentioned in resource planning. Although, the critical difference in managing the demand is the time horizon. In the shorter term, some methods to alter the load are not feasible (Chapman, 2006). Anyhow, with accurate forecasting and sound S&OP, the need for capacity management will be lower as overall resources should be in place (Chapman, 2006). More detailed capacity planning will then be more about fine-tuning. Forecasting methods and the S&OP should therefore be revised first if mismatches occur frequently. Lastly, it should be mentioned that it is the capacity that dictates the manufacturing, heavily influencing the flexibility (Jacobs et al., 2011). A completely balanced capacity and material plan will have no room to increase production on short notice. As a result, managers have to consider this aspect to become more dynamic and flexible in their production.

## 3.2 Lot sizing

Equal produced items on the same setup are called a lot, and the number of items in the lot is the lot size (Brahimi, 2004). *Lot sizing* involves the production planning problem of determining the optimal quantity and timing of the production (Jans and Degraeve, 2008). According to Karimi et al. (2003), lot sizing is one of the most challenging and essential problems within production planning. Lot sizing is an essential part of inventory management, and inventories tend to be one of the most extensive uses of capital (Jacobs et al., 2011). Inventories usually exist because there is a mismatch between supply and demand (Slack et al., 2019). Slack further explains that holding inventory can be costly and take up storage space. On the other side, the inventory can provide security against environmental uncertainties, smoothing the supply and demand. Therefore, the objective is usually to reduce the inventory levels but still keep the customer service level at a satisfactory level (Slack et al., 2019). Glock et al. (2014) states: "Determining the most economical inventory levels by balancing its positive and negative consequences in terms of cost has become one of the most influential research areas in the operations management literature", showing the importance of lot sizing.

Numerous methods and models are developed to solve the lot sizing problems considering different aspects of the problem. In general, the objective of lot sizing is to minimize costs by determining when and in what quantity to produce or order (Brahimi et al., 2006). In most cases, setup costs and holding costs are the costs that need to be minimized (Haase, 1994). The bigger lot sizes, the fewer setups are required. On the other hand, a bigger lot size can cause higher inventory levels and thereby higher holding costs. As there are many ways to approach the lot sizing

---

problem, the following section introduces some key characteristics that can be used to classify lot sizing models to get an overview of the problems.

### 3.2.1 Classification of lot sizing problems

Table 3.1, shows an overview of criteria that can be used to classify lot sizing problems. As can be seen, there are many variations and approaches to the problem. Brahimi et al. (2017) remarks that since the work of Brahimi et al. (2006), more than 100 publications on the single item lot sizing problems and extensions have been published. In their tertiary study, Glock et al. (2014) shows that published reviews of lot sizing has increased over the last years. The following section explains the characteristics needed to understand different models.

Parameter	Classifications
Information degree	deterministic, stochastic
Temporal development of parameters	static, dynamic
Planning horizon	finite, infinite
Time scale	discrete(small, large), continuous
Number of items	single, multi
Number of levels	single, multi
Relevant costs	setup, inventory, capacity
Resource constraints	number, type
Service policy	demand satisfied on-time, backorder, lost sales, sub-contracting
Time consuming activities	setup time, processing time, lead time, transportation time
Objectives	minimize costs, maximize service level, smoothing of production load, maximize profit

Table 3.1: Classification of lot sizing problems based on Haase (1994) and Brahimi et al. (2017).

#### Information degree

The lot sizing problems can be classified based on the information degree. If each variable has a known fixed value the problem is *deterministic*, while the problem is *stochastic* if the variables are uncertain (Haase, 1994). This could be for variables like demand (quantity and/or timing), capacity, setup time, machine breakdown, and more. The uncertainty in a stochastic model makes the underlying mathematical

---

model more complex than in a deterministic model, making the lot sizing problem harder to solve (Bushuev et al., 2015,). In stochastic models, the expected costs are minimized (Akartunalı and Dauzère-Pérès, 2021).

### **Temporal development of parameters, planning horizon, and time scale**

If the parameters in the model are constant over the period, the problem is *static*. The problem is *dynamic* if some of the variables change over time, such as demand, capacity, costs, and more (Haase, 1994).

The planning horizon can be classified as *finite* or *infinite*. Usually, the demand is dynamic in a finite planning horizon, whereas, in an infinite planning horizon, the demand is static (Karimi et al., 2003). Besides, the lot sizing problems can be classified into a *discrete* time scale or a *continuous* time scale. Discrete problems generally consider a finite time horizon, while continuous problems consider an infinite time horizon (Brahimi, 2004). The discrete problem can further be divided as either *big bucket* or *small bucket* problems (Karimi et al., 2003). With a big time bucket, the time period is so long that multiple items can be produced on the same machine (with a multi-item case) (Jans and Degraeve, 2008). With a small time bucket, there is only time to produce one item in the period on a machine.

The planning horizon can also be implemented as a *rolling horizon* (Karimi et al., 2003). When a period passes, it will be removed and replaced with a new period added at the end of the horizon (Federgruen and Tzur, 1994). The rolling horizon approach is very common for dynamic lot sizing as it allows for re-planning, incorporating new information about the system (Tavaghof-Gigloo and Minner, 2021). A rolling horizon is normally used in a stochastic model where there are uncertainties in the data (Karimi et al., 2003).

### **Number of items and number of levels**

One of the characteristics of lot sizing problems is the number of end items considered in the problem (Brahimi et al., 2017). The problems are mostly divided into single or multi items. In the *single item* case, only one product is produced, and it is the only product in the model. On the other hand, the *multi item* problem is faced with multiple end items. As a result, the multi-item level is significantly more complex as costs, demands, setups, and more are increasing with more end items in the model (Karimi et al., 2003). The multi-item problem with no capacity constraints can be reduced to a single item uncapacitated problem for each of the items (Brahimi

---

et al., 2006). On the other hand, a multi-item problem with capacity is a very challenging problem that has received much attention in the literature (Jans and Degraeve, 2007).

Another lot sizing problem characteristic of importance is the number of levels, where the production system can be single level or multi level. In a *single level* system, the end items are produced directly from the raw materials where there are no subassemblies or intermediates (Karimi et al., 2003). The single level lot sizing problem is often seen in industries like the medical and chemical industries, where the end products are created with one simple operation. The product demand in a single level system is said to be independent demand, generated directly from market forecasts or orders from the end customers. On the contrary, the end products in the *multi level* problem are created by several assemblies. There are now multiple levels from raw materials to the finished product creating a parent-component relationship, depending on the item structure (Brahimi, 2004). The demand of the intermediates is dependent on the parent, classifying this demand as dependent demand. As with the number of items, the number of levels increases the difficulty of solving the problem as the complexity magnifies (Karimi et al., 2003).

### **Relevant cost parameters**

Many relevant cost parameters can be incorporated in lot sizing problems. Haase (1994) explain four relevant types of costs as following. A *unit production cost* or *unit buy price* can be present in the problem. Additionally, there can be *setup related costs* or *changeover related costs* that are present when a setup or changeover is happening. These costs can be sequence dependent on the item structure or item scheduling. If the lot sizing problem considers ordering rather than production, the setup cost is called *ordering cost*.

Furthermore, there can be *inventory related costs*. The most important is *holding costs*, also called *carrying costs*. The holding cost represents the cost of holding an item in the inventory over a period of time. Many factors can decide the holding costs like capital, risk of obsolescence, insurances, taxes, and operations costs. If there are inventory shortages, penalty costs can be added, like backlogging or lost sales costs (Tempelmeier, 2013).

The last type of cost that can be involved in lot sizing problems presented by Haase (1994), is *capacity related costs*. These costs occur when capacity is used or increased, often involving the use of overtime, subcontracting, or change in the workforce level.

---

## Capacity or resource constraints

Lot sizing problems can be classified as uncapacitated or capacitated. When the lot sizing problem includes restrictions on capacity or resources, the problem is classified as *capacitated* (Karimi et al., 2003). If there are no restrictions, the problem is uncapacitated. Capacity constraints heavily influence the decision making in production planning (Li and Meissner, 2011). The capacitated lot sizing problem can include restrictions on variables like machines, workforce, equipment, capital, inventory, etc. The capacity restrictions make the lot sizing closer to real-world problems as the assumption of an infinite amount of resources is not realistic in most cases (Brahimi et al., 2017). A way to model the problem is to introduce a limited production capacity variable for each period (Absi and Kedad-Sidhoum, 2008). Production in the time period then consumes capacity from the limited variable. Love (1973) explored the problem in another way by adding inventory bounds to the inventory variable, meaning a lower and upper bound is set for the inventory variable. With capacity or resource constraints, there can be periods where the demand exceeds the capacity. This will have an impact on the timing and quantity of products in the other periods to make sure that the demand is met (Karimi et al., 2003). As a result, the capacitated problem is more complicated than the uncapacitated problem.

## Service policy

If the demand can not be satisfied in a period, a decision about the service level must be made. The unsatisfied demand can be considered as a *lost sale* or it can be delayed to a later time period, called *backlogging* (Haase, 1994). It is common to have a safety stock inventory to ensure that the service level is maintained when faced with uncertainties in supply, demand, and lead times. Tempelmeier (2013) summarize four different approaches to model the service level. The service levels can additionally be used as constraints in the lot sizing model, often done with stochastic demand (Tempelmeier, 2013).

## Time consuming activities

There are many time consuming activities that can be considered in lot sizing models, thereby classifying them. The activities can include *transportation time*, *lead time*, *processing time per unit* and *production speed* (Haase, 1994). If the problem is uncapacitated, the production speed is assumed to be infinite, or similarly, the pro-

---

duction time per unit is assumed to be zero. Many lot sizing problems assume that transportation, production, and/or setup take no time and happen instantly, while some consider these time consuming activities. When the setup time is considered, the setup time is determined by the setup structure of the item. The setup structure is called *simple* if the setup time and cost are the same for all sequences and decisions in previous periods. On the other hand, the setup structure is called *complex* if the sequence or previous decisions affect the time and cost (Karimi et al., 2003). The complex setups can be divided into three. The first one is a carry-over setup where the production of an item can be continued from the last period without any setups, reducing both costs and time. The second type of complex setup structure is family (major) and item (minor) setup. The family (major) setup occurs when there are similarities between groups of items and the production process. The item (minor) setup happens when the production change between items within the same family. The third complex setup type is sequence-dependent setup, and in this case, the production sequence determines the setup time and cost. Karimi et al. (2003) states that the complex setup structures make the lot sizing problems harder to solve. Notice also that the setup time can be a stochastic variable.

## Objectives

In most cases, the objective in lot sizing problems is to minimize the total costs. Alternatively, the objective could be to maximize the profit (Brahimi, 2004). However, the objective can also be to maximize the service level or to smooth the production load. Some lot sizing problems also consider scheduling simultaneously, often called the lot sizing and scheduling problem, where the goal is to determine the production quantity and the production sequence (Lee and Lee, 2021).

This paper will not review all the different models that can be developed based on these classifications. Instead, basic lot sizing problems will be in focus, as further extensions of these problems can be used to create more exact models of industrial problems (Jans and Degraeve, 2007). The static lot sizing problems will first be introduced to reflect the origin of the problem. Then, the main focus will be on dynamic lot sizing problems, where the single item uncapacitated and capacitated problems will be given most attention.

---

### 3.2.2 The static lot sizing problem

The first lot sizing problem was reported in 1913 by Ford W. Harris (Harris, 1990). Harris introduced the lot sizing problem as a static single-item model with constant demand, a continuous time scale with an infinite time horizon (Jans and Degraeve, 2007). The model was named the Economic Order Quantity (EOQ), where setup cost and inventory holding cost are balanced to avoid unnecessary inventory build-up (Glock et al., 2014). By using the average inventory level and setup required, the total costs  $TC$  can be formulated as shown in equation 3.1. The parameters average demand  $D$ , setup cost  $S$ , and holding cost  $h$  are assumed to be constant and deterministic.

$$TC = S\frac{D}{Q} + h\frac{Q}{2} \quad (3.1)$$

By minimizing equation 3.1 the economical order quantity  $Q^*$  is given by equation 3.2. The output is the replenishment quantity to produce, so total costs are minimized as a function of setup costs, inventory holding costs, and the average demand (Glock et al., 2014).

$$Q^* = \sqrt{\frac{2SD}{h}} \quad (3.2)$$

The assumption of constant parameters, making the model static, is not always the case in real-life problems. Therefore, the following sections will consider dynamic versions of the lot sizing problem. The most basic dynamic lot sizing problems, often acting as the base for more complex problems, will be introduced.

### 3.2.3 Dynamic lot sizing problems

#### The single item uncapacitated problem

The single item uncapacitated dynamic lot sizing problem is the simplest form of a dynamic lot sizing problem (Jans and Degraeve, 2008). This problem considers only the production of a single product and has no restrictions on capacity. As with the static EOQ model introduced in section 3.2.2, the single item uncapacitated lot sizing model considers the tradeoff between inventory and setup costs to minimize the total cost. However, there is a dynamic demand, discrete time scale, and finite time horizon (Jans and Degraeve, 2007). Despite being a simple problem, the single item

---

uncapacitated dynamic lot sizing problem is often used to solve sub-problems of more complex lot sizing models (Brahimi et al., 2006). In the single item uncapacitated dynamic lot sizing problem, the variables over the period 1 to the length of the decision horizon  $T$  are denoted as the following:

- $d_t$  = demand in period  $t$
- $h_t$  = holding cost per item carried from period  $t$  to period  $t + 1$
- $s_t$  = setup cost in period  $t$
- $x_t$  = products produced in period  $t$
- $I_t$  = inventory at the end of the period  $t$

The goal of the single item uncapacitated dynamic lot sizing problem is to decide when and in what quantity to produce in order to satisfy demand while minimizing the total costs (Brahimi et al., 2017). Equation 3.3 shows the objective function that is minimized subject to the restrictions in equation 3.4 and 3.5.

$$\text{Minimize } \sum_{t=1}^T s_t \delta(x_t) + h_t I_t \quad (3.3)$$

Subject to:

$$I_{t-1} + x_t = d_t + I_t \quad \forall t \in T \quad (3.4)$$

$$I_t, x_t \geq 0 \quad \forall t \in T \quad (3.5)$$

Three decision variables exist in the objective function (Jans and Degraeve, 2007). The production variable  $x_t$  deciding when and how much to produce, the setup variable  $\delta(x_t)$ , and the inventory variable  $I_t$ . There is a need for a setup in each period, and  $\delta(x_t)$  in the equation is a binary Heaviside step function indicating whether there is production in the period and is given by equation 3.6.

$$\delta(x_t) = \begin{cases} 0 & \text{if } x_t = 0 \\ 1 & \text{if } x_t > 0 \end{cases} \quad (3.6)$$

Constraint 3.4 is the inventory balance, where inventory from the previous period and produced items are used to satisfy demand in the period or build inventory for further demand (Jans and Degraeve, 2007). Restriction 3.5 makes sure that the production and inventory are never negative (Jans and Degraeve, 2008).



---

## The single item capacitated problem

The single item capacitated dynamic lot sizing problem can be viewed as an extension of the uncapacitated problem, and the complexity often depends on the capacity parameter (Brahimi et al., 2006). The capacity restrictions constrain the production quantity for each period (Karimi et al., 2003). A limited production capacity variable  $cap_t$  and a capacity consume variable  $v_t$  is often introduced to model the capacity usage. The main difference between the uncapacitated and capacitated problem is the additional capacity constraint shown in equation 3.7 (Jans and Degraeve, 2008).

$$v_t x_t \leq cap_t \quad \forall t \in T \quad (3.7)$$

## Stochastic lot sizing problems

A way to deal with uncertainty in demand is to model the dynamic lot sizing problem as stochastic (Sox et al., 1999). The future demand is often assumed to be equal to the expected value and solved with a linear programming approach (Salomon, 1991). Tarim and Kingsman (2004) states that forecasted demand is often treated as deterministic demand, not evaluating forecast accuracy or errors. Wemmerlöv (1989) investigated how forecast errors impact the performance of lot sizing models, concluding that stockouts and more extensive inventories were the results of forecast errors. In a stochastic environment, the inventory quantities required to assure a specific service level rise dramatically (Winands et al., 2011). Brahimi et al. (2017) presents the three following different strategies for stochastic lot sizing based on recent literature:

- *Static strategy*: This strategy executes production plans without considering new demand information. Setups and production quantity are decided in advance and often beneficial with limited capacity.
- *Dynamic strategy*: The strategy involves forecasting the whole planning horizon but only deciding on plans for the first period. When new demand information is available, an updated production plan is made.
- *Static-dynamic strategy*: In this strategy, decisions about setups are made prior to the whole period, but the quantity of the product is evaluated for each period with the latest demand information.

The dynamic and static-dynamic strategy is often combined with the rolling horizon approach and primarily used in stochastic lot sizing models to manage the uncertainty in the demand (Tavaghoof-Gigloo and Minner, 2021). Lot sizes for immediate periods can be decided before the horizon is rolled forward, and more updated information about demand, inventory and capacity can be taken into consideration (Charles et al., 2021). This approach allows for re-planning and can reduce safety stock inventories (Tavaghoof-Gigloo and Minner, 2021). Figure 3.6 illustrates the rolling horizon approach.

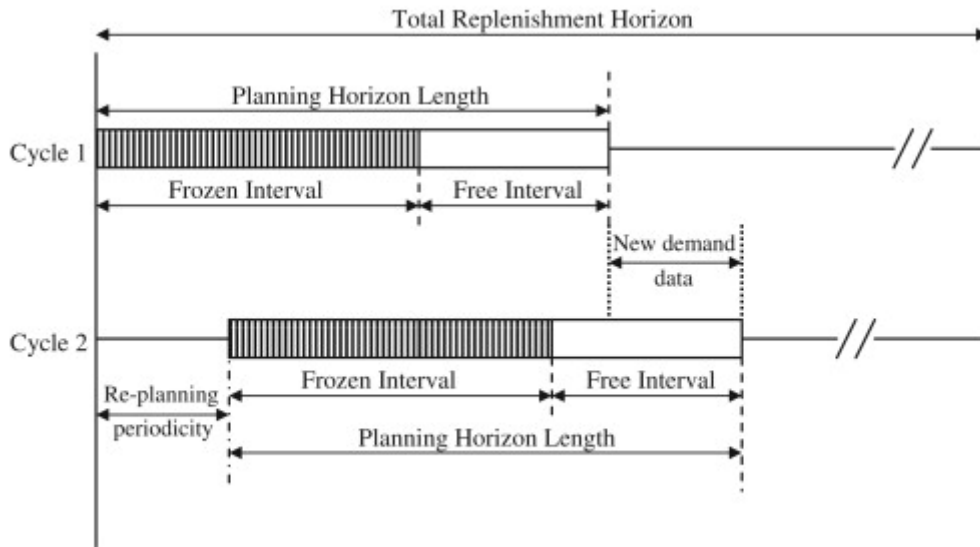

Figure 3.6: Illustration of rolling horizon planning environment, from Narayanan and Robinson (2010)

Despite the benefits of information updates, there are some challenges with the rolling horizon effect. The optimal solution for each period is not a guarantee of an optimal solution for the whole planning period, making each period act as a heuristic (Karimi et al., 2003). Additionally, an end-of-horizon effect can occur as many solutions involve having zero inventory at the end of the horizon, which might not be optimal when the new horizon is added (Charles et al., 2021). Further, dynamic lot sizing with a rolling horizon approach can cause nervousness in the system, mainly from the end-of-horizon effect and effects of revising data (Federgruen and Tzur, 1994). Nervousness in an MRP system happens when many changes in the production plan ripple through the bill of materials causing changes in several components (Chapman, 2006). To reduce the nervousness, parts of the planning horizon can be frozen, meaning changes cannot be made in these periods (Sahin et al., 2013).

---

## Solution approaches

A huge variety of lot sizing problems has emerged from the most basic dynamic lot sizing problem introduced here. Dynamic lot sizing models are often adjusted to fit a specific real world problem, making the parameters and input of the model different for each problem. As a result, different solution approaches to the problem have evolved over time. Wagner and Whitin (1958) were the first to address the single item uncapacitated dynamic lot sizing problem as the EOQ model did not provide optimal solutions when the demands differed for each period. To solve the problem, they used a dynamic programming recursion (Jans and Degraeve, 2007). Dynamic programming is a common way to solve lot sizing problems and is an implicit enumeration method (Brahimi et al., 2006). However, models can be formulated as Mixed Integer Linear Programming (MILP) models, as the single item uncapacitated and capacitated dynamic problem in this section has been (Pochet and Wolsey, 2006). Single item uncapacitated problems are often not solved with MILP, but as more complex models often use these models to solve sub-problems, they are also formulated as MILP (Brahimi et al., 2017). Capacitated problems are mainly solved by linear or mixed integer programming model (Guillaume et al., 2017). MILP models can be solved with optimization software, usually using a branch-and-bound or branch-and-cut algorithm to find the optimal solution (Gurobi Optimization, LLC, 2022).

## 3.3 Demand forecasting

Hyndman and Athanasopoulos (2018) defines demand forecasting as the art of predicting future customer demand as accurately as possible, using all the information you have available. Forecasts help companies anticipate demand fluctuations which enable them to have the necessary capacity and materials available to quickly and reliably respond to their customers (Stevenson et al., 2014). Accurate forecasts are crucial to ensure flexibility and responsiveness in the supply chain (Stevenson et al., 2014). Inaccurate forecasts may lead to shortages and excesses throughout the supply chain. Shortages of materials, parts, and services can lead to underproduction, missed deliveries, and work disruption resulting in poor customer service (Stevenson et al., 2014). Additionally, overly optimistic forecasts may lead to overproduction and excess capacity and materials, which in turn raises costs (Stevenson et al., 2014). However, a forecast is simply an inference of what is likely to happen in the future and not an absolute certain prophesy (Dilworth, 1996). Given the complexity and

---

randomness of most real-world variables, it is very difficult to accurately predict the future values of these variables consistently (Stevenson et al., 2014). Consequently, it is important to have an indication of the extent of deviation the forecast have from the actual value. Decision makers would want to include forecasting accuracy as a key factor when choosing a forecasting technique (Stevenson et al., 2014). Some common measures of forecast error include mean square error (MSE, equation 3.8) and mean absolute percentage error (MAPE, equation 3.9) (Chen and Yang, 2004).

$$MSE = \frac{1}{n} \sum_{i=1}^n (Y_i - \hat{Y}_i)^2 \quad (3.8)$$

where

MSE: Mean squared error

$n$ : Number of data points

$Y_i$ : Observed value for data point  $i$

$\hat{Y}_i$ : Predicted value for data point  $i$

$$MAPE = \frac{1}{n} \sum_{t=1}^n \frac{A_t - F_t}{A_t} \quad (3.9)$$

where

MAPE: Mean absolute percentage error

$n$ : Number of data points

$A_t$ : Actual demand at time  $t$

$F_t$ : Predicted demand for at time  $t$

Demand forecasts are useful for all functions in a manufacturing firm (Moon, 2018), although different departments have different needs regarding the forecast granularity, horizon, and interval. The forecast horizon refers to the length of time for which the forecast is intended, whereas the forecast interval is the period between two forecasts (Stevenson et al., 2014). Moon (2018) discussed key functions and corresponding needs of forecasting, summarized in Table 3.2.

---

	<b>Needs</b>	<b>Forecast horizon</b>	<b>Forecast interval</b>
<b>Marketing</b>	Marketing requires a forecast of expected demand in order to effectively prepare promotional activities, new product introductions, and similar demand generation activities.	One to two quarters	Quarterly
<b>Sales</b>	Sales requires a demand forecast to derive reasonable sales quotas. In addition, it is needed to effectively allocate sales resources to the sub-departments and customers where they can be best utilized.	One quarter to one year	Quarterly or annually
<b>Finance</b>	The finance department needs a forecast to be able to plan for working capital requirements as well as to create future financial projections for the company and for government reporting.	One month to one year	Monthly
<b>Sourcing</b>	Strategic need: Long-term contracts with suppliers of required raw materials and components. Tactical need: To manage short-term raw material and component deliveries and inventories	Lead time dependent	Monthly
<b>Logistics</b>	Strategic need: To manage long-term contracts with transportation providers and warehousing assets. Tactical need: To manage short-term transportation requirements and day-to-day distribution center management	Lead time dependent	Monthly
<b>Operations</b>	The operations department needs demand forecasts to schedule manufacturing runs in the most efficient manner, and to plan for expanded capacity if it is required to meet the expected customer demand.	Lead time dependent	Weekly to monthly

Table 3.2: How forecasts are used by different functions in a manufacturing company. Adapted from Moon (2018).

### 3.3.1 Forecast horizons

Forecasts are made with a pre-defined time horizon in mind (Stevenson et al., 2014). The time horizon may be fairly short, ranging from a week to a month or longer, cov-

---

ering months or years (Stevenson et al., 2014). Table 3.3 displays the time horizons corresponding to different forecasting categories (Lewis, 2012). Each forecasting horizon has its own application and requires the forecasting technique best fitting to that horizon (Hyndman and Athanasopoulos, 2018). Manufacturers often have multiple forecasts, each of which focuses on a different time horizon, in order to facilitate decisions that involve different lead times (Dilworth, 1996). The appropriate time period for one decision may be inappropriate for another. Food manufacturers typically have a long-term forecast to support strategic decisions, as well as a short-term forecast to support tactical, day-to-day operations (Takey and Mesquita, 2006). It is important that there is a coherency between the short-term and long-term forecasts. The short-term forecast should support the objectives established by the long-term forecast (Dilworth, 1996).

Type of forecast	Length of forecast horizon	Update frequency (interval)
Immediate-term	1 hour to 1 day	Daily
Short-term	1 week to 1 month	Weekly
Medium-term	1 month to 1 year	Weekly to monthly
Long-term	1 year to 1 decade	Quarterly to yearly

Table 3.3: Typical lengths and update frequencies for different forecast categories (Lewis, 2012).

### Long-term demand forecasting

As illustrated in Table 3.3, a long-term forecast typically has a forecast horizon of one year to one decade. According to (Moon, 2018), the length of a long-term forecast should at least be as long as it takes to create additional manufacturing capacity. Demand may increase to the point where new capacity is required to meet the extra demand. Increasing production capacity for food manufacturers may require new machines, expansion of already existing manufacturing facilities, or building a new manufacturing facility. The long-term forecast horizon should at least be as long as the time it takes to implement the capacity expansion efforts (Moon, 2018).

The long-term forecast, being the forecast with the longest time frame, is a key input to strategic decisions regarding sourcing and logistics as these decisions typically have an extended lead time (Dilworth, 1996). For food manufacturers, decisions

---

in these areas commonly involve creating and managing long-term contracts with suppliers, wholesalers, and retailers (Moon, 2018). Logistical decisions related to warehousing and transportation typically also have a longer lead time and require a reasonable estimation of long-term demand (Dilworth, 1996). The forecasting hierarchy, as illustrated in Figure 3.7, is highly relevant for the long-term forecast (Moon, 2018). The hierarchy starts at the bottom by estimating the demand for a single product during the forecast horizon in stock-keeping units (SKU). As an example, a confectionery manufacturer will at this level estimate the number of each of its sugar and chocolate products that are anticipated to be sold each month during, for example, the next year. Moving up the product hierarchy level, the forecasts for each product belonging in the same brand can be combined, to answer the question: "How much of a specific brand of products will be demanded each month the next year?". Moving further to the product family level, forecasts of different brands in the same product family can be combined to answer the question, "What will the demand be for all chocolate and sugar products each month the next year?". Finally, all chocolate and sugar product forecasts can be combined to arrive at the overall company forecast. In most cases, these hierarchical relationships are defined in a manufacturer's ERP system (Section 3.1.7). The ERP system takes the complete company forecast as input and calculates the required resources to produce the anticipated demand, thus facilitating long-term decisions (Moon, 2018).

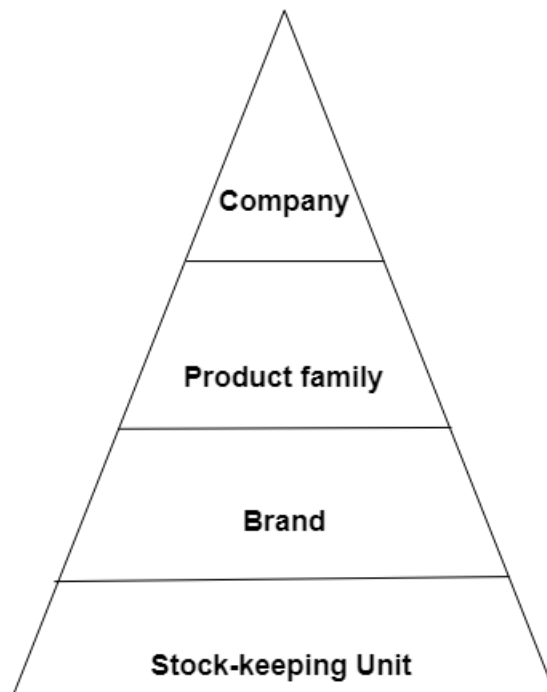

Figure 3.7: Product hierarchy adapted from (Moon, 2018).

---

## Short-term demand forecasting

Short-term forecasts have a time horizon ranging from 1 week to 1 month (Table 3.3), and are especially helpful in planning and scheduling day-to-day operations (Stevenson et al., 2014). In general, forecast accuracy increases as the forecast time horizon decreases (Stevenson et al., 2014). Consequently, flexible companies that are capable of responding quickly to demand fluctuations typically benefit from accurate shorter-range forecasts and obtain a competitive advantage over the less flexible companies that must use longer forecast horizons (Stevenson et al., 2014).

Short-term forecasts usually take recent sales data alongside expert judgment and opinions as input in order to tweak the long-term forecast according to the current market situation (Lewis, 2012). Food manufacturers have shown to benefit from shorter-ranged forecasts, much due to the varying demand uncertainty caused by new product introductions and promotional activity (Verdouw, Beulens, Trienekens and Wolfert, 2010). A food manufacturer will be better able to effectively respond to demand fluctuations through forecasts with shorter time horizons, so long as it is able to adjust its production in time to meet the change in demand (Verdouw, Beulens, Trienekens and Wolfert, 2010). According to Moon (2018), the absolute minimum time length of the forecasting horizon is the production lead time. A safety time length should, in most cases, be added to account for unpredictable events. The short-term forecast is generally not changed as regularly as the long-term forecast. A manufacturing company may choose to freeze the forecast for its entire duration, meaning that no changes will be made to the forecast after its creation. Another approach is to freeze the first couple of weeks but allow edits to the remaining weeks for as long as the company has the ability to adjust the production in time to meet changes in demand.

### 3.3.2 Forecasting methods

Forecasting methods are typically categorized as either qualitative or quantitative (Spyros G. Makridakis, 2008). A qualitative approach involves collecting and appraising judgments, opinions, and best guesses from experts to make predictions (Slack et al., 2019). Common qualitative forecasting methods include the panel approach, Delphi method, and scenario planning (Mateus Meneghini, 2018). Quantitative methods are characterized by using well-defined processes for data analysis. Spyros G. Makridakis (2008) explains that quantitative forecasting can be applied only if all of the following three conditions are met:



- 
1. Information about the past is available.
  2. This information can be quantified in the form of numerical data.
  3. It can be assumed that some aspects of the past pattern will continue into the future.

According to Chiung Song (2007), quantitative methods can produce more precise results than qualitative methods since they employ objective criteria less susceptible to subjective errors. On the other hand, the authors argue that on occasions when there are contextual factors that cannot be included in the statistical model, the qualitative model obtains a better performance in the forecast. The two main approaches to quantitative forecasting are time series analysis and causal modeling (Slack et al., 2019).

### **3.3.3 Causal modelling**

Causal modeling is a forecasting approach that tries to evaluate the cause-effect relationship between key variables used in the demand forecast Friston et al. (2003). Complex techniques are used to comprehend the strength of relationships between the causal variables and the impact they have on each other (Fildes et al., 2019). A simple regression model is an example of a common causal model that uses one independent variable to predict the outcome of another dependent variable (Gomila, 2021).

Understanding the correlation between key variables is crucially important to create accurate demand forecasts for food producers (Lewis, 2012). For example, Hvolby and Steger-Jensen (2015) argues for the importance of knowing how price adjustments on one product can affect the demand for other products in the same category. This phenomenon is called sales cannibalization and is quite common in the food sector. The promotional uplift of one product causes a reduction in sales for other products within that category (Hvolby and Steger-Jensen, 2015). By not adjusting the demand for the other products in the same category, one can often experience overproduction.

### **3.3.4 Linear regression**

Linear regression is one of the most vastly used causal models. As the name suggests, the model predicts values within a continuous numerical range by finding a

---

linear relationship between one or more predictor variables and the outcome variable (Gomila, 2021). Equation 3.10 presents the linear regression formula.

$$Y = \beta_0 + \beta_1x_1 + \beta_2x_2 + \dots + \beta_nx_n \quad (3.10)$$

where

$Y$ : Predicted value (dependent variable)

$\beta_0$ : Constant (the line intercept on the Y-axis)

$\beta_1 \dots \beta_n$ : Slope coefficients (also called the model weights)

$x_1 \dots x_n$ : Feature values (independent variables)

The simplest form of linear regression is a model predicting a single dependent variable with only a single independent variable and is given by Equation 3.11.

$$Y = \beta_0 + \beta_1x \quad (3.11)$$

The goal of the model is to determine the intercept  $\beta_0$  and set of weights  $\beta_1, \beta_2, \dots, \beta_n$ , which forms a regression line that best matches the data. These coefficients are obtained by minimizing the mean squared errors (MSE - Equation 3.8) between the actual data points and the fitted line, in order to form a linear hyperplane that most appropriately describes the observations (Kuhn and Johnson, 2016).

### 3.3.5 Time series forecasting

Time series forecasting examines the historical demand pattern over time in order to estimate the pattern's future behavior (Stevenson et al., 2014). By only taking into account historical demand data, an assumption is made that the demand trend in the past will remain unchanged (Mark Davis, 2003). Quantitative time series forecasting methods can be categorized as either statistical or machine learning based (Parmezan et al., 2019). Each forecasting technique has its advantages and disadvantages, hence the situation which is forecasted needs to be assessed (Waters, 2008). In particular, the data material and data availability must be evaluated (Shaohui Ma, 2016).

---

## Statistical forecasting methods

The first real application of statistical models for the purpose of time series forecasting dates back to the late 1920s (Zoubir, 2017). At that time, simple linear regression methods were applied, and the moving average model was introduced as an effective way to identify and remove fluctuations in time series data (Equation 3.12). When using moving average, the forecaster can decide how many periods to include in the calculation, thus eliminating irrelevant demand history (Moon, 2018). A plethora of research studies has been conducted to investigate the effectiveness of using simple statistical methods for demand forecasting in food retail (Priyadarshi et al., 2019). The studies have found that simple statistical models perform very well in terms of accuracy and ability to be implemented in a manufacturing company (de Almeida and da Veiga, 2022; Mou et al., 2018; Sargut and Isik, 2017).

$$F_{t+1} = \frac{D_t + D_{t-1} + \dots + D_{t-(N-1)}}{N} \quad (3.12)$$

where:

$F_{t+1}$  = Forecast for period t+1

$D_t$  = The demand for period t

$N$  = Number of periods in the moving average

## Exponential smoothing

Today, the most widely used time series methods in the literature are still statistical methods such as moving average and exponential smoothing (Abraham and Ledolter, 2009). Exponential smoothing is an adaptation of the moving average that expands on the idea of eliminating old, irrelevant data from the calculation (Moon, 2018). Forecasts generated using exponential smoothing methods are weighted averages of past observations where the weights decay exponentially as the observations get older (Hyndman and Athanasopoulos, 2018). In other words, the more recent the observation, the higher the associated weight meaning it will affect the forecast to a larger degree than more distant observations. This framework produces accurate forecasts quickly and for a wide range of time series, which is a significant benefit for industrial applications (Stevenson et al., 2014). The simplest exponential smoothing method is called simple exponential smoothing and is suitable for forecasting data with no evident trend or seasonal pattern (Hyndman and Athanasopoulos, 2018). The formula is as follows:

---

$$F_{t+1} = \alpha D_t + (1 - \alpha)F_t \quad (3.13)$$

where:

$F_{t+1}$  = Forecast for period t+1

$F_t$  = Forecast for period t

$D_t$  = The demand for period t

$\alpha$  = The smoothing coefficient ranged between 0 and 1

More advanced adaptations of exponential smoothing are required to forecast time series data containing trend and seasonality. One popular adaptation is called the Holt-Winters' method and is widely used in retail forecasting (Hyndman and Athanasopoulos, 2018).

### **Holt-Winters' method**

Holt (2004) and Winters (1960) extended the simple exponential smoothing method to capture seasonality and trend. The Holt-Winters method is a forecast equation comprised of three smoothing equations. Each smoothing equation helps produce a forecast by capturing one of the following key components:

- Level: The local average in the time series
- Trend: The magnitude of increase or decrease in value between successive time points in the time series
- Seasonality: The deviation from the mean due to repeating cycles in the series.

There are two variations to the Holt-Winters formula - additive or multiplicative - which are determined depending on the seasonal component. The additive method is preferred when the seasonal variations are roughly constant throughout the series, while the multiplicative method is preferred when the seasonal variations are changing proportionally to the level of the series (Hyndman and Athanasopoulos, 2018). The following equations show the formulas for the additive and multiplicative variations of Holt-Winters:

#### **Additive:**

$$F_{t+n} = L_t + nB_t + S_{t+m-s} \quad (3.14)$$

---

$$\begin{aligned}
\textbf{Level: } L_t &= \alpha(F_t - S_{t-m}) + (1 - \alpha)(L_{t-1} + B_{t-1}) \\
\textbf{Trend: } B_t &= \beta(L_t - L_{t-1}) + (1 - \beta)B_{t-1} \\
\textbf{Seasonality: } S_t &= \gamma(F_t - L_t) + (1 - \gamma)S_{t-m}
\end{aligned}
\tag{3.15}$$

**Multiplicative:**

$$F_{t+n} = (L_t + nB_t)S_{t+m-s} \tag{3.16}$$

$$\begin{aligned}
\textbf{Level: } L_t &= \frac{\alpha F_t}{S_{t-m}} + (1 - \alpha)(L_{t-1} + B_{t-1}) \\
\textbf{Trend: } B_t &= \beta(L_t - L_{t-1}) + (1 - \beta)B_{t-1} \\
\textbf{Seasonality: } S_t &= \frac{\gamma F_t}{L_{t-1} + B_{t-1}} + (1 - \gamma)S_{t-m}
\end{aligned}
\tag{3.17}$$

Where

$F_{t+n}$  = Forecasted value at period  $t + n$

$L_t, T_t, S_t$  = Level, trend and seasonality components of the series at time  $t$

$\alpha, \beta, \gamma$  = Smoothing coefficients

$m$  = Number of periods in one seasonal cycle

### Machine learning forecasting methods

Although statistical methods provide satisfactory forecasting accuracy in many cases, a fundamental weakness is that they simply look at past behavior to predict future demand, ignoring causal variables (Makridakis et al., 2018b) (Section 3.3.3). Food manufacturers may benefit from including other data such as inventory levels, promotional ventures, and competitor activities alongside previous demand data to increase forecast accuracy (Fildes et al., 2019). Due to this fact, other time-series forecasting methods have been explored in recent literature, including machine learning based methods which have shown promising results (Parmezan et al., 2019).

As the number of forecasting parameters increases, it becomes more difficult to choose the appropriate technique in a particular context. One possible solution is

---

to rely on a class of algorithms called “universal approximators,” which can approximate any function to an arbitrary accuracy (Pavlyshenko, 2019). Machine learning (ML) techniques, such as artificial neural networks and support vector machines, are examples of such universal approximators and can be used to learn any function (Réal Carbonneau, 2007). They allow the inclusion of supply chain data alongside historical demand data to enhance the forecast. Whereas traditional statistical time-series models simply apply past patterns to future demand, machine learning models go a step further by trying to define the actual relationship between variables and their associated demand patterns (Småros and Kaleva, 2020). In addition, whereas statistical methods require manual manipulation of the baseline forecast to accommodate the impact of, for example, upcoming promotions or price changes, machine learning based methods can be customized to automatically consider these factors in a single model. One of the most prominent machine learning methods to use for time series demand forecasting is using a type of recurrent artificial neural network called long short-term memory (LSTM) network (Pavlyshenko, 2019). The following sub-sections give an introduction to the architecture of neural networks.

### **Artificial neural network (ANN)**

An artificial neural network (ANN) is a computational model that is built to mimic the architecture of the human brain (Yegnanarayana, 2009). It is used to build intelligent agents through multiple iterations of learning. At its base, an artificial neural network is made up of layers of perceptrons, which are simple computational units that send weighted inputs through an activation function and produce a single numeric value as output. A variety of activation functions can be used, including step function, linear, and non-linear functions. The job of the activation function is to determine whether the degree of impact the single neuron should have on the final output of the network. An artificial neural network consists of an input layer, an output layer, and one or more hidden layers, each of which contains one or more perceptrons (Yegnanarayana, 2009). When a neural network includes more than one hidden layer, it is referred to as a deep neural network, giving rise to the term “deep learning” (LeCun et al., 2015). Neural networks are built to discover and interpret patterns in the input data, which is why they have proven to be very good at forecasting time series data (Pavlyshenko, 2019). Figure 3.8a displays a simple perceptron, and Figure 3.8b illustrates a neural network containing an input and output layer as well as two hidden layers.

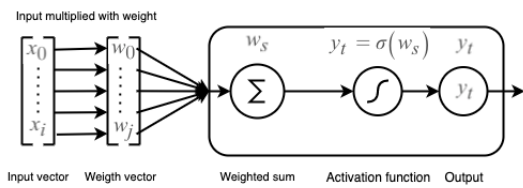

(a) A single perceptron (artificial neuron)

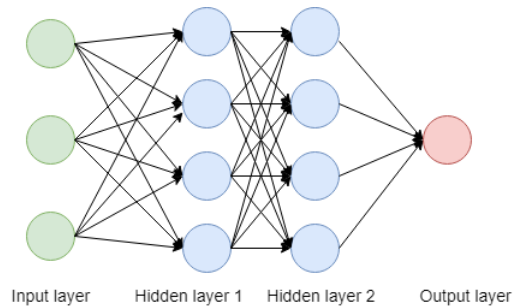

(b) Artificial neural network with two hidden layers

Figure 3.8: Overview of a perceptron and an artificial neural network

## Recurrent neural network (RNN)

A recurrent neural network (RNN) is a specialized neural network built to detect and interpret the sequential information contained in the input data (Mikolov et al., 2010). Regular artificial neural network assumes that the inputs are independent, which is true in many cases (Yegnanarayana, 2009). However, when dealing with sequential data, such as time series, the input sequence contains key information which must be captured in order to make accurate predictions (Fildes et al., 2019). The hidden layers of a recurrent neural network have connections back to themselves, through so-called loops. These loops makes it possible to utilize historical information by transferring data from a previous time step into the calculation for the current time step, making the RNN able to capture the underlying sequential information better (Abiodun et al., 2018). Figure 3.9 displays a folded and unfolded representation of an RNN. At each time step  $t$ , the current input  $x_t$  is fed to the model alongside the output from the previous time step  $h_{t-1}$  which are combined to calculate the new output at time  $t$ .  $w_h, w_y$  and  $w_x$  represents the weights of perceptrons contained in the input, hidden and output layers. These weights are initialized somewhat randomly, but are adjusted during training to fit the data in order to make better predictions.

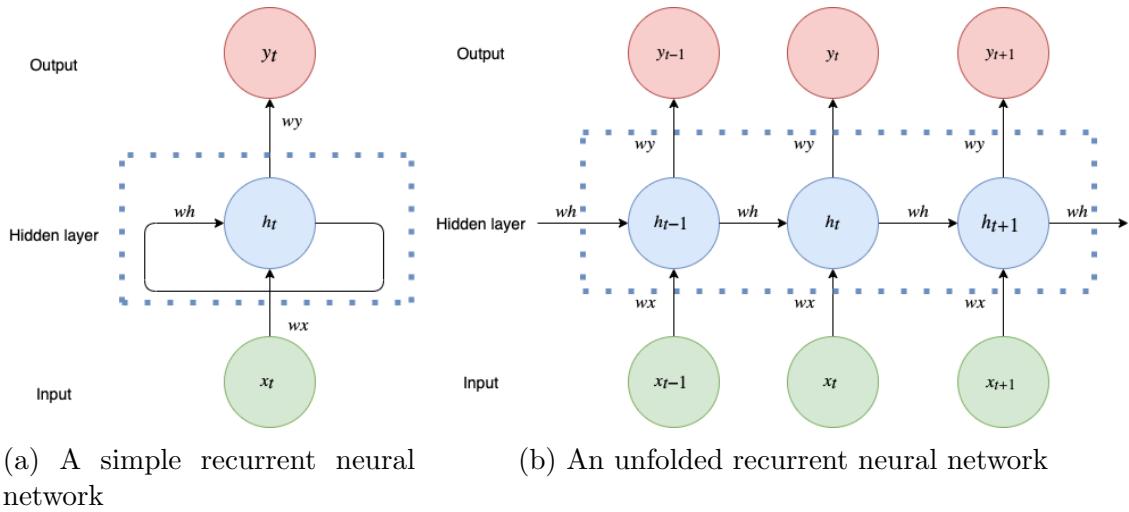

Figure 3.9: Recurrent neural networks

### The vanishing and exploding gradient problem

Recurrent neural networks are good at capturing underlying sequential information, however, they struggle to detect long-term dependencies in the data (Hochreiter, 1998). This is much due to the problem of exploding or vanishing gradients, particularly affecting the perceptrons in the first layers of the network. During back-propagation, the network's weights are updated in proportion to the gradient of the loss function with respect to the weights in the network (Hochreiter, 1998). Each layer in the network have an activation function which typically squishes a large input space into a small input space, normally between 0 and 1, hence making the derivative small. When  $n$  small derivatives are multiplied together as we propagate down the network, the gradient decreases exponentially. A vanishingly small gradient prevents the weights in the network from changing its value effectively and proportionally, slowing down or in the worst case, stopping the network from further training. The minimal change in network weights will not contribute much to minimizing the prediction error. The opposite can also happen if the gradient grows to be excessively large, in which case the network weights gets updated too much and dis-proportionally, also resulting in no significant contribution in minimizing the prediction error. These issues can be solved with the use of a long-short term memory (LSTM) network.

### Long short-term memory (LSTM)

Long short-term memory (LSTM) networks are a type of recurrent neural networks that prevents the problem of exploding and vanishing gradients. The network con-



---

tains LSTM layers which are made up of specialized LSTM cells that are specifically built to capture long-term dependencies. Accurately capturing the level and magnitude of the trend and seasonal components of time series data is critically important to perform accurate forecasting (Abbasimehr et al., 2020). The LSTM cell is specifically designed to maintain important information from past observations and forget unimportant information.

Figure 3.10 illustrates the architecture of an LSTM cell. The cell consists of 3 gates, namely an input gate, an output gate, and a forget gate. Each gate aids the network in learning long-term dependencies by selecting what data to keep and what data to discard. In addition, the cell has an internal cell state,  $c_t$ , that serves as the cell's long-term memory and is updated as new data passes through it. Finally, the cell has a hidden state,  $h_t$ , which serves as the cell's short-term memory and simply contains the cell's output from the previous time step.

The calculations performed in the cell consists of the four following steps (Olah, 2015), as illustrated in Figure 3.10:

The first step is to decide what information to discard from the cell state, which is determined by the forget gate. The new input  $x_t$  and the previous hidden state,  $h_{t-1}$ , is multiplied by the weights of the forget gate, added with the bias of the forget gate, and passed through a sigmoid function (equation 3.18). The sigmoid function returns a final value,  $f_t$ , that ranges between 0 and 1, where a value close to 0 indicates that the information was forgotten and a value close to 1 indicates that the information was retained.

$$f_t = \sigma(W_f[h_{t-1}, x_t] + b_f) \quad (3.18)$$

The next step is to determine what new information to store in the cell state, which is decided by the input gate. A sigmoid layer,  $i_t$  (equation 3.19), decide what values to update, while a hyperbolic tangent layer,  $C'_t$  (equation 3.20), generates a vector of candidate values to potentially add to the new cell state. Finally, these values are multiplied together to obtain the new candidate values for the cell state scaled by how much the sigmoid layer decided to update each state value (equation 3.21).

$$i_t = \sigma(W_i[h_{t-1}, x_t] + b_i) \quad (3.19)$$

$$C'_t = \tanh(W_c[h_{t-1}, x_t] + b_c) \quad (3.20)$$

---

$$G_t = i_t * C'_t \quad (3.21)$$

Where  $W_i$  and  $b_i$  are the weights and bias of the input layer, and  $W_c$  and  $b_c$  are the weights and bias of the hyperbolic tangent layer.

The third step is to update the cell state. This is accomplished by multiplying the old state,  $C_{t-1}$ , with the values from the forget gate,  $f_t$ , thus forgetting the data that the forget gate judged unimportant. Then we simply add the new candidate values  $G_t$  and we are left with the new cell state,  $C_t$  (equation 3.22).

$$C_t = C_{t-1} * f_t + G_t \quad (3.22)$$

The final step is to determine what the cell should output, which is decided by the output gate. The cell's previous hidden state,  $h_{t-1}$  is passed through a sigmoid function alongside the current input,  $x_t$ , to decide what parts of the cell state the cell should output,  $o_t$  (equation 3.23). Following, the new cell state,  $C_t$ , is passed through a hyperbolic tangent function and multiplied by  $o_t$  to produce the output and new hidden state,  $h_t$  (equation 3.24).

$$o_t = \sigma(W_o[h_{t-1}, x_t] + b_o) \quad (3.23)$$

$$h_t = o_t \tanh(c_t) \quad (3.24)$$

### 3.3.6 Forecasting new product launches

Demand forecasting of new products is particularly challenging as historical data is not available as an indicator of future demand (R.M. van Steenberg, 2020). Planners usually have limited analysis time, and there is a high uncertainty related to consumer acceptance and competitive reactions (Lee et al., 2014; Baardman et al., 2017). Even so, accurate demand forecasting of new products is of great importance, particularly because many industries are facing shorter product life cycles (Basallo-Triana et al., 2017). The forecast guides operations such as capacity planning, procurement, and inventory control. Previous research has shown that failing to manage these tasks appropriately can be particularly costly when dealing with new products (Lee et al., 2014; Basallo-Triana et al., 2017; Wright and Stern, 2015).

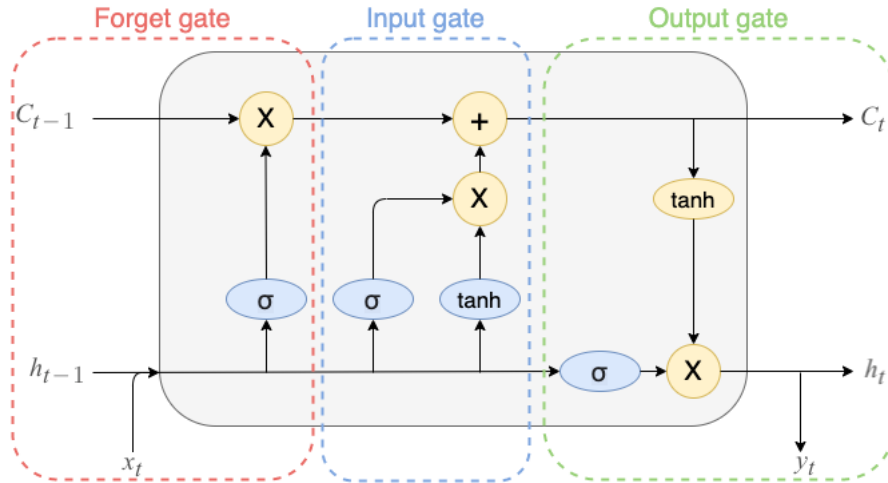

Figure 3.10: Overview of an LSTM cell

Different types of new product launches will result in different demand profiles (Gelper et al., 2016; Surathkal et al., 2017). For example, the demand for a completely new product will likely differ from that of a new product launch within an already existing category. According to (Kahn, 2014), new product launches can be categorized into the following seven types: cost reductions, product improvements, line extensions, new markets, new uses, new category entries, and new-to-the-world products. Kahn (2002) and Kahn (2005) goes on to explain that each category differs in reported forecast accuracy, where bigger changes in most cases lead to a lower prediction accuracy. Consumers tend to respond differently depending on the type of new product, which stresses the importance of selecting the appropriate forecasting method (Kahn, 2014).

Qualitative methods such as expert opinions and surveys are the most widespread techniques applied for new product launches, as they do not require historical data (Kahn, 2002). However, recent literature has explored quantitative approaches for forecasting new product launches (R.M. van Steenberg, 2020; Machuca et al., 2014). Goodwin et al. (2013) argue that quantitative models should be at the core of the forecasting process of new products. Arguably the most widely used quantitative method for new product forecasting is the bass model (Kahn, 2014). The model describes the process of how new products get adopted in a population as an interaction between adapted customers and potential customers (Bass, 1969). The heart of the model is a differential equation that gives rise to a function estimating the incremental sales in future periods (Equation 3.25). The Bass model, first published in 1969, has withstood the test of time and explains the "s-curve" that the cumulative demand profile of new products typically resembles (Babu, 2018).

---

Figure 3.11 illustrates an example of the s-curve one gets by implementing the Bass model.

$$S(t) = [p + q(\frac{Y(t)}{M})] * [M - Y(t)] \quad (3.25)$$

where:

$$Y(t) = \sum_{i=1}^{t-1} S(i) \quad (3.26)$$

and where:

$S(t)$  = Incremental sales in period t

$Y$  = Cumulative adoptions to date

$p$  = Coefficient of innovation

$q$  = Coefficient of imitation

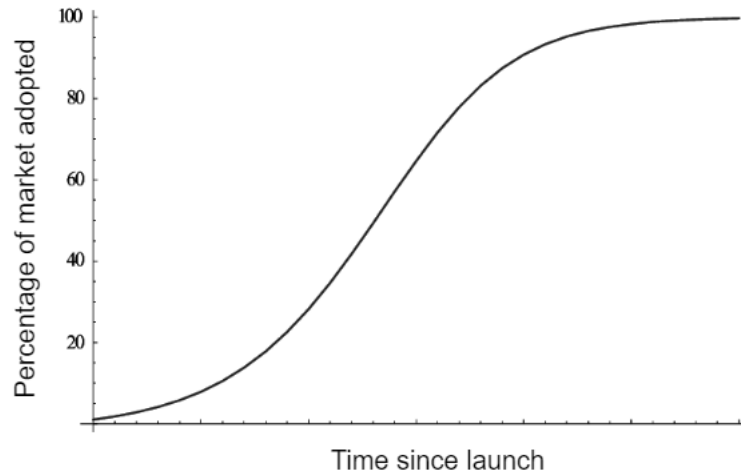

Figure 3.11: Bass model S-curve

In newer times, the Bass model has been adopted and improved through the use of machine learning methods (R.M. van Steenberg, 2020). The general idea of such a machine learning model is to perform similarity clustering of old products to categorize the new product in relation to already existing products (Lee et al., 2014). From there, one can perform curve fitting of past products to determine the p and q coefficients used in the Bass model. By combining the similarity clustering with its corresponding coefficients, it is possible to obtain an estimated demand profile of a new product without the use of historical data. The result is a pre-launch forecast which can support inventory management decisions for new products.

---

### 3.3.7 High-frequency forecasting using point of sales data

Point of sales (POS) data is information collected at the retail store that provides volumetric information on every transaction made (Banerjee and Banerjee, 2000). A single point of sales data point typically includes the quantity sold of a given product, the price at which the transaction was made, the exact time of the transaction, and possibly added information regarding promotional activity at the retail store at the time of the transaction. The increasing availability of customers' transaction level data at the point of sale has facilitated the exploration of high-frequency forecasting in the grocery retail (Dharmawardane et al., 2021). Food manufacturers typically generate forecasts on a monthly or weekly basis, hence forecasting at smaller intervals, such as daily, can be considered high frequency (Fildes et al., 2019). According to Fildes et al. (2019), high frequency forecasting can aid in identifying granular levels of seasonality in demand which in turn helps manufacturers and retailers improve product freshness and availability while reducing spoilage, overstocking, and inventory costs. POS data is absolutely essential in facilitating high-frequency forecasting for food manufacturers (Hartzel and Wood, 2017; Dharmawardane et al., 2021).

Although the use of POS data is heavily appraised in the literature (Chen and Lee, 2009; Lee et al., 1997, 2000), high-frequency forecasting has proved operationally challenging for entities in a food supply chain (Dharmawardane et al., 2021). Wholesalers, having millions of SKU-store combinations, struggles to account for demand variation at high frequencies without introducing manual decisions in the forecasting process (Hartzel and Wood, 2017). However, simply due to the vast amount of data processing required to perform high frequency forecasting, the process must be automated in order to be feasible (Dharmawardane et al., 2021). Seaman (2018) illustrated the scale of the problem through an analysis of Walmart stores in the USA. There are approximately 5000 Walmart stores across the USA. A single store can hold more than 200 000 products, which makes for approximately 1 billion forecasts at store-product level. Creating high frequency forecasts of each store-product combination is not feasible if manual adjustments are required. Performing this kind of high frequency forecasting on all combinations requires state of the art big data analytics (Choi et al., 2018), which leads to major implications for digitalization of operations management (Holmström et al., 2019). Manufacturers face the same challenge. Although they may not have as many product combinations to create forecasts for, they instead have to account for lead times in material and component replenishment which will affect their capability of performing high frequency forecasting (Dharmawardane et al., 2021). Forecasting must be done at an interval and

---

with a time horizon that allows the manufacturer to make changes to the production to meet the new forecasted demand (Fildes et al., 2019).

An area where POS data has proven particularly important is in determining the success of new product launches (Småros, 2005). Forecasting new products is, as elaborated on in Section 3.3.6 particularly challenging as historical data is limited. However, by monitoring early POS data, manufacturers can get an early indication of how well the new product is selling and can begin estimating the expected demand profile of the new product (Småros, 2004). So long as the manufacturing company is capable of altering their production to rapid demand fluctuations, early POS data monitoring can help reduce the risk of stock-outs and enable rapid correction of overly optimistic pre-launch forecasts (Småros, 2005).

## **3.4 Information sharing in supply chains**

This section delves into the advantages and challenges of vertical information sharing in the food supply chain. A brief explanation of the bullwhip effect, a critical consequence of lack of information sharing, is presented. Then, opportunities, benefits, and challenges with information sharing are addressed.

### **3.4.1 The bullwhip effect**

Demand distortion, also known as the bullwhip effect, refers to the amplification of demand variability when moving upstream in the supply chain (Lee et al., 1997). As demand fluctuations occur at the consumer level, the grocery stores will order more from the wholesaler to keep up with the rising demand. This might trigger the wholesaler to order an excessive amount from the manufacturer in anticipation that the demand will continue to rise. Finally, the manufacturer may feel obligated to produce even more in anticipation that the demand from the wholesaler will continue to rise. In most cases, the result is an increase in production variability and the need for buffer stock (Småros, 2005). This, in turn, drives up costs due to inefficient capacity utilization, overtime, stock-outs, warehouse space, and more (Romsdal, 2014).

Lee et al. (1997) discusses the four following primary causes of the bullwhip effect, which are heavily supported in more recent literature (Wang and Disney, 2016; Bhattacharya and Bandyopadhyay, 2011):

---

## **Demand forecast updating**

Each echelon of a supply chain typically performs its own demand forecasting (Paik and Bagchi, 2007). These forecasts are usually based on the order history for the company's immediate downstream customer (Dulsrud and Alfnes, 2016). When the downstream customer places an order, the upstream entity processes that signal and readjusts its demand forecast. In so doing, the upstream entity will send a new signal to its upstream echelon, which in turn, readjusts its forecasts (Lee et al., 1997). Furthermore, each supply chain echelon has its own safety stock policy, which creates varying demand requirements for different entities in the supply chain. The more entities in the supply chain, the more the problem will propagate upstream in the supply chain, and the less these forecast updates will reflect the actual end-customer demand.

## **Order batching**

Each company in a supply chain have its own specific inventory control policy (Lee et al., 1997). As inventory is depleted, the downstream company may choose to not place an order immediately but instead accumulate demand before issuing an order. This accumulation leads to bigger orders which can be interpreted as a surge in demand even though it is not actually reflected by the end-consumer demand. Furthermore, manufacturers typically round up or down the order quantity received from their downstream customer to suit production constraints such as equipment setup or truckload quantities. The more companies that customize their order batching, the more distortion will be made on the original quantities demanded.

## **Price fluctuation**

According to Lee et al. (1997), an estimated 80% of transactions between manufacturers and distributors in the grocery industry are made in an arrangement where items are bought in advance of requirement, usually because manufacturers offer an attractive price offer. Price discounts, quantity discounts, coupons, and rebates all contribute to order variability that does not reflect the demand at the given time. Upstream entities can misinterpret the extra demand as an increase in end-consumer interest, although that may not be the case.

---

## **Rationing and shortage gaming**

When the demand of a product exceeds a manufacturer's available inventory, the manufacturer may choose to allocate the available inventory to its customers in proportion to the amount ordered from the different customers. If downstream entities are aware that the manufacturer will ration the products when it is in short supply, they may make an upward adjustment to the order quantity to ensure they receive what they actually need at the time they need it. This rationing and gaming create distortions in the ordering information that is being received by the supply chain, exacerbating the bullwhip effect (Lee et al., 1997).

## **Information sharing to combat the bullwhip effect**

Information sharing across entities in the supply chain is widely recognized as a means of mitigating demand distortion (Lee et al., 1997). However, there is a disconnect between the ideal integrated supply chain and reality (Gunasekaran et al., 2004). Many companies are unaware of the benefits of information sharing and collaborative forecasting. Premkumar (2001) identifies the following 6 challenges that must be assessed to allow for successful supply chain collaboration:

- Alignment of business interests
- Long-term relationship management
- Reluctance to share information
- Complexity of large-scale supply chain management
- Competence of personnel supporting supply chain management
- Performance measurement and incentive systems to support supply chain management.

### **3.4.2 The value of information sharing in supply chains**

Advancements in technology have facilitated information sharing and moved it to an increasingly electronic character over the years (Jorgenson et al., 2000). Viet et al. (2018) conducted a thorough study of recent literature to investigate and quantify the value of information sharing in supply chains. Figure 3.12 displays the different information types that were studied in the articles reviewed. Effects on



---

demand uncertainty and inventory level were the most researched and were also the areas that displayed the most significant gain by increased information sharing (Viet et al., 2018). The research of Cui et al. (2015) showed that the value of downstream sales information to upstream firms stems from improving upstream order fulfillment forecast accuracy. Such an improvement can lead to lower safety stock and better service levels (Cui et al., 2015). The research is supported by Kovtun et al. (2019), Wei et al. (2019), and Pei and Yan (2019) that all found that increased information sharing reduces the bullwhip effect, causing a reduction in demand uncertainty for upstream echelons.

Cui et al. (2015) and Mason-Jones and Towill (1997) examined the value of manufacturer access to POS data. Both articles argued that the manufacturer is the supply chain entity that receives the most benefits from increased information sharing. Mason-Jones and Towill (1997) examined a case where a company got a sudden increase in demand, greater than 20%. A demand increase of that size can happen due to various reasons such as promotional or marketing efforts, new product launches, or when products move into season. The effect on inventory and production control was measured and compared against a scenario where only order data is used in decision making, without access to POS data. Their results show that demand amplification and response time were reduced significantly. When the manufacturer had access to POS data in real-time, the delay of the initial response to demand fluctuations was eradicated, and overstocking was significantly reduced. Additionally, the findings of Cui et al. (2015) showed that safety stocks could be reduced significantly as demand forecasts are more accurate and reliable when having access to POS data. Lotfi et al. (2013) elaborated on the findings and argued that manufacturers are better fit to reduce the initial pipeline fill prior to the launch of a new product if they receive access to POS data for the new product at an early stage.

Smáros (2005) performed a case study on a food supply chain containing a retailer, a logistics and purchasing company, and two manufacturers. The research examined how manufacturers in practice can utilize access to POS data in managing new product launches. Forecast accuracies and service levels were measured and compared before and after the beginning of the information sharing cooperation with the retailer. The key account manager of one of the manufacturing companies claimed that access to POS data was a key factor in securing availability for at least two of the products included in the study. The research showed that there would have been a significant stock-out risk for the new products without access to POS data, as their initial forecasts were much too low. Additionally, access to POS data reduced the response time and increased forecast accuracies which is consistent with the findings of Kovtun et al. (2019), Cui et al. (2015), and Pei and

Yan (2019). Pei and Yan (2019) and Småros (2005) also explored the effect on the logistics and retail companies. Their findings showed that the increase in service level directly benefits the logistics company and leads to reduced inventory and less likelihood of stock-outs. In addition, the retailer saw opportunities to increase store replenishment efficiency by using the updated forecasts from the manufacturer to set parameters in their automatic store ordering system. The benefits proved huge for new product launches, but neither the manufacturer nor retailer saw any worthwhile benefit in sharing POS data for standard, mature products, as they believed the forecasts based on sell-through data were accurate enough. Cachon and Fisher (2000) supports this claim by stating that sharing of downstream sales data is likely to have a significantly greater value in situations of unknown demand.

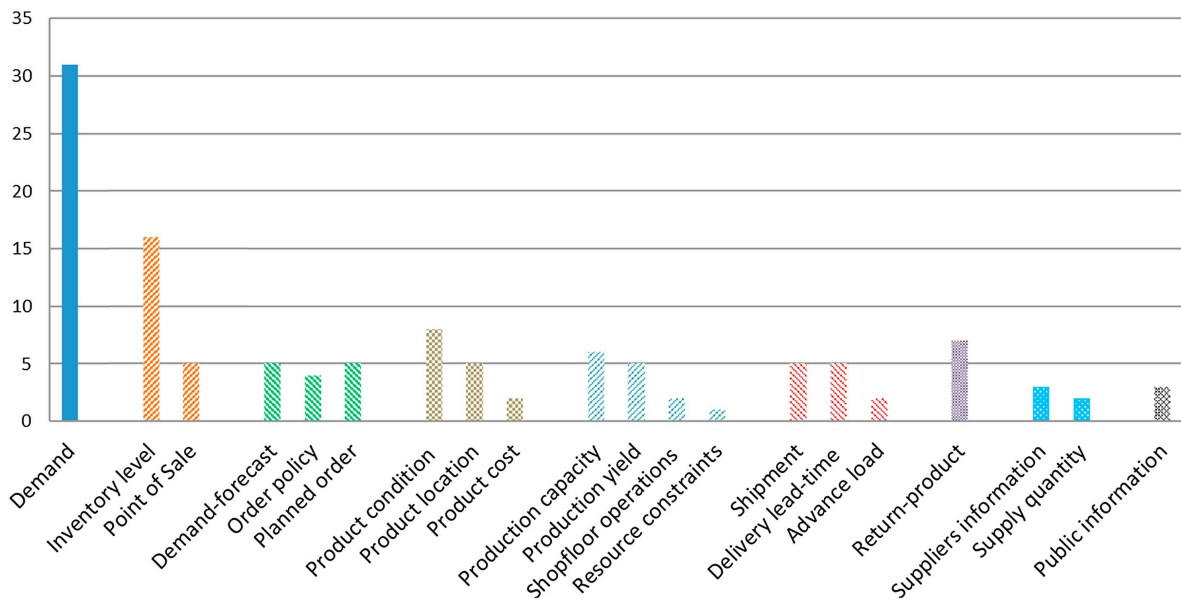

Figure 3.12: Number of recent articles (2006-2016) on information sharing per information type studied by Viet et al. (2018)

### 3.4.3 Challenges with information sharing

Although the literature points to numerous advantages of sharing data with supply chain partners, the research also shows that there are substantial hurdles that must be handled. These issues are inextricably linked to the following question posed by Lee et al. (2000): "What is the minimum set of information to share with my supply chain partners without risking potential exploitation?".

In a case study in the food industry, Nakayama (2000) discovered that information exchange influences the power relationship between grocery stores and their wholesalers, affecting their mutual trust. Although sharing information with supply

---

chain partners may result in efficiency advantages, it also forces retailers to expose key strategic knowledge, exposing them to opportunistic conduct by suppliers, as argued for by Mohtadi and Kinsey (2005). Furthermore, the authors explain that a retailer with lots of suppliers will have a stronger motivation to share information because they are less reliant on individual suppliers, making them less subject to such opportunistic behavior.

Kim and Shin (2019) and Vergin and Barr (1999) examined the effect of continuous replenishment planning (CPR) on all entities in the supply chain. CPR is an agreement where the supplier takes control of the inventory management decisions of the buyer (Parsa et al., 2017). In the case of Vergin and Barr (1999), the manufacturers determined when and how much of its goods the wholesaler or retailer should order. Of the 10 companies studied, all reported that their customers achieved significant improvements through lower inventories and fewer stock-outs. Furthermore, 8 of the 10 manufacturers reported an increase in sales. However, only two of the companies claimed better management of production, and only one achieved lower internal inventories. The same challenges were found in the study of Kim and Shin (2019). This demonstrates that the producer faces difficulty in successfully utilizing downstream supply chain data in practice. Despite the fact that the majority of studies indicates that manufacturers will benefit the most from information-sharing efforts, many manufacturers appear to have had difficulty realizing these benefits in practice (Lapide, 2002).

---

# Chapter 4

## Empirical Background

The following section presents the empirical background of the Norwegian food supply chain, outlining its structure and fundamental characteristics. Further, it delves into the most common ways of performing demand forecasting, particularly how Norwegian food producers handle exceptional demand such as for new product launches. Lastly, the current state of information sharing across actors in the Norwegian supply chain is addressed.

### 4.1 Characteristics of the Norwegian food supply chain

The food supply chain is characterized by a high variety of products produced in large volumes with low profit margins (Georgiadis et al., 2020). Perishability and short shelf life are two essential characteristics of food products, which have significant implications for how they are handled along the supply chain (Romsdal, 2014). Raw materials, intermediates, and finished products have varying constraints regarding shelf-life (van der Vorst, 2000). Perishability challenges affect manufacturers differently as some produce products with shelf-lives of months to years, while others produce products with shelf-lives of only some days (Romsdal, 2014). Retailers and wholesalers require short lead times and frequent deliveries to prevent changes in product quality as the product progresses through the supply chain (Dreyer et al., 2015). Perishable products naturally tend to have a higher order frequency than less perishable products although delivery frequencies in general are quite high (Verdouw, Wolfert, Trienekens, Top, Van der Vorst and Beulens, 2010).

The traditional food supply chain in Norway serves a dynamic marketplace with

---

a diverse variety of consumer segments that demand high service levels and low pricing (Dreyer et al., 2015). Consumers seek convenience through alternative options for purchasing food, such as through internet shopping with home deliveries, although wholesaler distribution is most common (Erland Skogli, 2020). Norwegian wholesalers demand a service level as high as 97.5% which puts much pressure on the producer to deliver the right quantity at the right time (Romsdal, 2014). Failure to fulfill the required service level can result in loss of goodwill and have a negative influence on further negotiations with the wholesaler regarding prices, assortment, product introductions, collaborative marketing and more (Romsdal, 2014). Due to the substantial consequences of not meeting the required service level, food producers put much emphasis on ensuring constant product availability (Dreyer et al., 2016). For most products, inventory costs are low compared to the cost of lost sales (Ketzenberg and Ferguson, 2008). As a result, producers prefer having large inventories of finished products to ensure meeting the demand of their customers (Dreyer et al., 2016, 2014; Romsdal, 2014). Large inventories resolve the issue with meeting demand, but makes for an increase in scrapping and waste, as well as excess capacity in distribution and production departments (Lee et al., 1997). Over the last few decades, Norwegian food producers and wholesalers have invested majorly in structure and infrastructure as a means of overcoming such inefficiencies (Pettersen, 2013). The production have been centralised and specialized, with large-scale production systems being invested in (Romsdal, 2014). Similarly, distribution channels have been industrialized thanks to extremely efficient warehousing and logistics systems that emphasize centralization, big volumes, and economies of scale (Dreyer et al., 2018; Romsdal, 2014).

The Norwegian food market is dominated by three major wholesalers having a large aggregated market share of ordinary retail distribution (NielsenIQ, 2021). These wholesalers are NorgesGruppen, COOP, and REMA 1000, each owning one or more associated retail chains. NorgesGruppen is the biggest with a market share of approximately 44%, followed by COOP with a market share of 29%, and REMA 1000 at 23% (NielsenIQ, 2021). In total, the three wholesalers distribute to approximately 3800 grocery stores (NielsenIQ, 2021). Norway has one of the highest densities in Europe of grocery stores per inhabitant at 400 grocery stores per one million inhabitants (Dulsrud and Alfnes, 2016).

---

## 4.2 Structure of the Norwegian food supply chain

There are four main actors in the Norwegian supply chain: Raw material producers, an industrial manufacturing or processing unit, wholesalers, and retailers (Dulsrud and Alfnes, 2016). A wholesaler distribution is most common, where the material flow goes from the manufacturer to the wholesaler, then to the retailer, and finally to the end-consumer (Romsdal, 2014). In recent times, however, some wholesalers and manufacturers have implemented direct distribution to the end-consumer, giving them the ability to purchase food online right to their door (Erland Skogli, 2020). Figure 4.1 shows the various distribution channels for food products and illustrates the wholesaler distribution.

In Norway, the wholesaler and the stores they supply are integrated. The idea is that the retailer can order a wide range of products from one single wholesaler instead of having to contact every individual producer (Schulze et al., 2006). A single wholesaler with a large inventory increases product availability for the retailers, while the retailers themselves can have small inventories, which is cost-effective (Saitone and Sexton, 2017). The wholesaler acts as an effective intermediary between manufacturers and retailers, as economies of scale ensure that features such as purchasing, assortment, sales and transportation are taken care of in an efficient manner (Tiwari, 2020). The consolidation and vertical integration have led to major productivity gains by streamlining the information and material flow across supply chain entities (NielsenIQ, 2021). However, the typical Norwegian food supply chain can still be considered fragmented with many actors and limited cooperation and information sharing (Romsdal, 2014). The finished-goods products are stored at many different stock points as it moves down the supply chain, and the demand is aggregated at each supply chain actor (Romsdal, 2014). As a result, as one proceeds up the supply chain, upstream actors' information on end-customer demand becomes distorted, resulting in artificial demand variation known as the bullwhip effect (Section 3.4.1) (Lee et al., 1997).

## 4.3 Demand forecasting

Demand uncertainty of food products are varying, and the demand is generally becoming more unpredictable (Verdouw, Beulens, Trienekens and Wolfert, 2010). The increase in demand variability is largely caused by an increased frequency in promotional activities, as well as an increase in new product introductions (Huchzermeier and Iyer, 2006). Due to the high demand fluctuations in the food industry, food

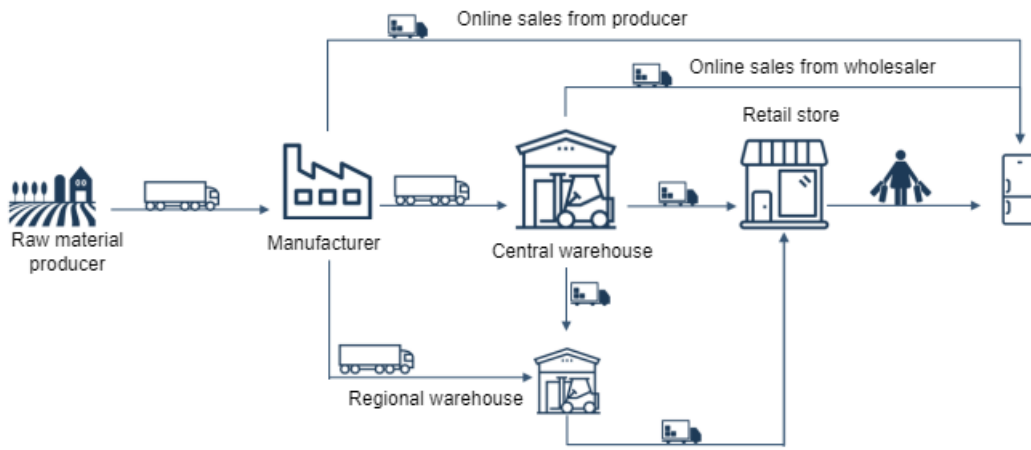

Figure 4.1: Distribution channels of food products

manufacturers struggle to know when to have available stock on hand and when to keep stock levels slim (Hua and Li, 2008). Increased demand variability makes accurate demand forecasting particularly important (Pujara et al., 2022). The research of (Dreyer et al., 2016) and (Dreyer et al., 2018) shows that food manufacturers primarily base their forecasts on historical orders from the wholesaler, alongside expert judgement from in-house planners. Due to the seasonal and promotional demand patterns of food products, food manufacturers need to account for different types of demand when calculating a demand forecast.

### Regular demand

Food manufacturers typically estimate the regular demand for all their pre-existing products 6-18 months ahead (Takey and Mesquita, 2006). The regular demand excludes any promotional activities and new product introductions. Many manufacturers use an enterprise resource planning (ERP) system to perform and store this long-term forecast (Erland Skogli, 2020). Food manufacturers have reported that they obtain a reasonably high forecast accuracy when estimating regular demand through simply using historical orders as primary input to the forecast (Moon, 2018). Basic statistical time series methods are commonly used for forecasting such as the moving average and exponential smoothing. This long-term forecast is used as input alongside information regarding capacity constraints on the machines to the production plan which calculates the weekly production.

---

## Campaign demand

The regular demand of a product is altered when the extent of promotional activities is agreed upon through conversations with the wholesaler and its associated retail stores (Romsdal, 2014). Volumes for campaigns and other market activities are normally agreed with retail chains six weeks in advance to reduce demand uncertainty related to such market activities (Romsdal, 2014). Most of the orders are automatically exchanged through a portal solution (Dreyer et al., 2015). The campaign demand is typically estimated through expert opinions from planners at the manufacturer and retail chain based on empirical knowledge of similar campaigns (Stevenson et al., 2014).

## Demand of new product launches

Implementation of flexible automated production equipment has led to an increase in product variety (Bourlakis and Weightman, 2008). Increased product variety stresses the importance of accurate demand forecasting of new products. The average product life-cycle is decreasing as new products have a high failure rate, meaning it is important to not produce a new product in excess before launch (Horvat et al., 2019). However, because wholesalers require high service levels, manufacturers are typically saturated with a product prior to launch, holding several months' worth of stock on hand (Pinna et al., 2018). This extensive production is called a pipeline fill and is a result of high demand uncertainty for new products.

When a manufacturer wants to launch a new product, they send a new product launch offer to the wholesalers. If the wholesalers accept the offer, they will send a note called a listing indicating where the product will be placed on the store shelves, and in how many stores (Romsdal, 2014). With that information, the manufacturer can begin to estimate the expected demand during the launch period. Demand planners typically rely on their own expertise judgement as well as information of previous similar product launches due to the lack of historical data (R.M. van Steenbergen, 2020). The manufacturer also negotiate with the wholesalers and retail stores to finalize the anticipated demand. Depending on the production capacity constraints the manufacturer may start production several months ahead of launch. Additionally, due to the uncertainty regarding demand, the manufacturer may store several months worth of anticipated demand prior to launch (Pinna et al., 2018).



---

## 4.4 Current state of information sharing in the Norwegian food supply chain

The consolidation between wholesalers and retail stores facilitates information sharing. Point of sales data is continuously sent to the wholesaler's ERP system and used alongside information of planned campaigns in demand algorithms to create a replenishment policy for different products (Erland Skogli, 2020). COOP operates with an automatic replenishment policy where an order is automatically sent once the inventory drops below a given threshold (Dreyer et al., 2015). This way of organizing the information flow in a supply chain is called efficient consumer response and ensures constant availability of products with high quality and low price (Wood, 1993). However, the food manufacturer is not integrated with the wholesaler and does not benefit from collaborative planning and forecasting (Dreyer et al., 2018). According to Dreyer et al. (2016), normally, the only information shared between the food producers and the wholesalers is the orders from the wholesalers. The collaboration barrier is illustrated in Figure 4.2. Each entity in the supply chain does some processing on the demand signal before passing it along to the next member (Dreyer et al., 2018). As the end-customer's demand signal moves up the supply chain, it is increasingly distorted because of this demand signal processing (Lee et al., 1997). Due to lack of information sharing the upstream entities are not able to capture the demand distortion, disabling them to see the actual true demand. Research on Norwegian food producers have shown that producers tend to produce too much, and store managers tend to order too much because they lack the necessary information to make the right decision regarding quantity (Dreyer et al., 2016).

In recent years, some food producers have acquired access to supply chain data from the wholesaler and its associated retail chains (Dulsrud and Alfnes, 2016). Some of the data that have been shared includes sales from the wholesaler warehouses to the retail stores, inventory levels at warehouses and in stores, and point of sales data from the grocery stores. All food products sold in Norwegian retail stores are required to be registered in the electronic product database of Tradesolution (Dulsrud and Alfnes, 2016). The Tradesolution platform also host information about all stores in Norway as well as sales to these stores. Some food producers have purchased access to this data to gain knowledge of the ordering policy for their products downstream in the supply chain. The idea is to use the data to capture and prevent demand distortions and to calculate a more accurate demand forecast (R.M. van Steenberg, 2020). Research in the Norwegian food industry points to severe upsides through increased information sharing in areas such as lead time, reliability, stock level and

---

food wastage (Romsdal, 2014; Dreyer et al., 2016). A more transparent data system allows the actual undistorted customer demand to determine when, what and how to produce, as well as when and what products to pick, pack and deliver (Dreyer et al., 2016). Most manufacturers in Norway are still in an early adaptation phase in terms of utilizing these resources.

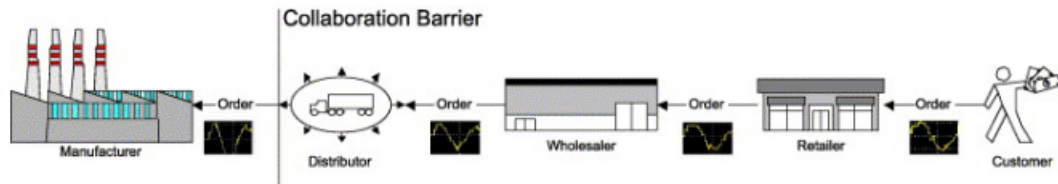

Figure 4.2: Collaboration barrier

---

# Chapter 5

## Case Study

A case study was conducted to investigate the effects of dynamic lot sizing with forecasted demand based on point of sales data for an existing food manufacturer. The first section of the case study is an introduction to the case company, Brynild. The introduction is based on our qualitative data collection and presents characteristics of Brynild and its supply chain, as well as their current use of point of sales data, and way of performing production planning and control. The emphasis is on new product launches as it is the scope of this master's thesis. The next section describes the data cleaning and transformation performed on the quantitative data used for the data analysis. Following, a descriptive analysis of the cleaned data is presented to display key characteristics of Brynild's new product launches. Then, the models developed for the case study, including the forecasting models and lot sizing models, are described. These models are applied to the quantitative data of Brynild, and the effects on costs and service levels resulting from employing them are compared to that of Brynild's approach. Lastly, the final section discusses the findings discovered.

### 5.1 Introduction to the case company

Brynild is a Norwegian chocolate, sugar confectioneries, and nut manufacturer. Its headquarters and only manufacturing facility is situated in Fredrikstad, where all self-made products are produced. The company employs around 200 people and has an annual turnover of around 750 million NOK, with 90% of sales going to Norway and the remaining to Sweden, Denmark, and Finland. Brynild produces products in the six product categories illustrated in Figure 5.1. Den Lille Nøttefabrikken, Dent, Minde Sjokolade, and St. Michael are among Brynild's most well-known brands. In

the Norwegian snacks and confectionery supply chain, national manufacturers like Brynild are challenged by global manufacturers, which have a substantial market share (NOU, 2011). The chocolate and sugar confectionery only make up 5% of the total market value of sales in Norwegian grocery stores (Nielsen, 2020). Brynild's market shares range from a small competitor in the chocolate industry to market leaders in the Norwegian nut market. Brynild manufactures approximately 45 variants of sugar confectioneries, 45 variants of chocolate, and 70 variants of nuts. The case study is focused on new product launches, and new products are launched each year during three different launch periods. The first launch period is in February, the next in May, and the last in September. Brynild launches many different types of new product introductions, where the most common are brand new products, re-launches, and line extensions. How different the new product is from already existing products is an important factor contributing to the likelihood of success. Brand new products are more difficult to predict the likelihood of success compared to line extensions. In general, only a few new products succeed per year.

The production facility in Fredrikstad has three separate production lines producing candy, nuts, and chocolate, respectively. Each production line is strictly isolated from the others to ensure no contamination between production lines. In particular, it is of extreme importance to ensure that sugar and chocolate products are not contaminated with traces of nuts. The strict isolation means that each production line operates as a separate factory. However, all production lines share the same packaging line.



Figure 5.1: Brynild's products

---

### 5.1.1 The supply chain

Brynild is a part of a six-echelon supply chain as illustrated in Figure 5.2. Following production, all products are transported to Leman, a third-party logistics company. Leman is used as there is limited storage space at the factory in Fredrikstad. The products are stored at Leman and picked and packed there when orders arrive. The orders are then picked up by wholesalers and transported to their central and regional warehouses. Brynild supplies the three largest wholesalers in Norway: NorgesGruppen, COOP, and REMA 1000. The three wholesalers make up around 90% of Brynild's total sales. Each wholesaler has its associated retail chains, and in total Brynild's products are delivered to almost 4000 grocery stores across Norway.

As mentioned in section 4.2, Norwegian wholesalers and the retail stores they supply are integrated. This case study focuses on the integrated wholesaler and retail umbrella chain, NorgesGruppen. NorgesGruppen has four major retail chains, KIWI, MENY, SPAR, and Joker, with around 1800 stores and a market share of approximately 44%. ASKO is the name of the wholesaler and distributor in NorgesGruppen. ASKO operates 13 regional warehouses and two central warehouses, one for refrigerated goods and the other for dry goods. Orders from retail stores are sent to their respective regional warehouse. If parts of the products in an order are stored at the central warehouse rather than the regional warehouse, the products are sent from the central warehouse to the regional warehouse before being distributed to the retail store with the other products.

Continuous sharing of supply chain data, such as point of sales data, facilitates effective information and material flow for the integrated partners. However, Brynild is not integrated with its wholesalers, and Brynild's information sharing with supply chain partners is limited. Brynild receives orders from the wholesalers they sell to and uses historical orders in their forecast to predict future demand. Basing their forecast solely on historical wholesaler orders leaves them unable to identify end-customer demand fluctuations as they occur. Brynild does not recognize a surge or plunge in end-consumer demand before they receive an order from the wholesaler. That is why Brynild wants to explore analysis and forecasting using POS data, with hopes of seeing added benefits from identifying demand fluctuations at an earlier stage.

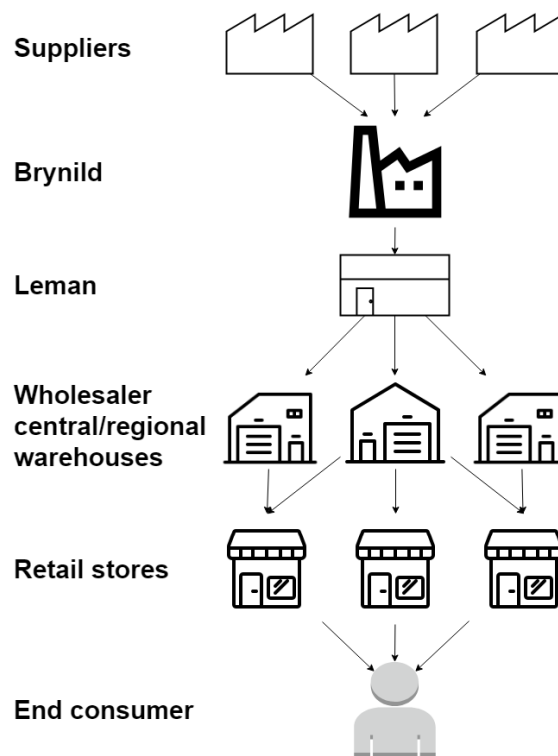

Figure 5.2: Illustration of the 6-echelon supply chain of Brynild

### 5.1.2 Current use of point of sales data

When anticipating future demand, Brynild does not use point of sales data. Nor do they continuously monitor point of sales data to adjust the demand plan if the actual demand looks to significantly subceed or exceed the anticipated demand. However, the marketing team at Brynild did monitor point of sales data during the new product launch of their nuts in plastic cups in 2020. The marketing team noticed that the demand for some products looked to exceed what was forecasted, while other products sold significantly less than anticipated. As a result, Brynild altered their production to produce more of the products that sold well and less of those that did not. The case proved why monitoring point of sales data early in the product life cycle could help meet the customer demand better.

Brynild has the possibility to download point of sales data for its products periodically. However, the POS data is aggregated and three weeks delayed, making it challenging to apply in decision-making processes. Brynild has collected batches of historical POS data for research purposes in recent years. Five years of POS data, from 2015 to 2020, has been collected from NorgesGruppen. Historical POS data from COOP has been made available on request but with a limited download size. Some POS data from REMA 1000 has also been made available, although

---

limited. Brynild wants to explore the possibilities of using POS data to enhance their forecasting and production planning. Investigating ways of doing so is the main objective of our case study.

### **5.1.3 Production planning and control at Brynild**

The production process of Brynild can be categorized as mainly batch processes and with some repetitive flow processes, where the products go through some sort of processing, like washing, cooking, roasting, mixing, and packaging. The products are produced in batches with standardized processes, ensuring the quality and similarity between the products. The production environment is make-to-stock, where the customer order decoupling point is located at the finished goods warehouse of Leman. The production is, therefore, mainly based on forecasts and inventory levels.

The case study investigates new product launches, but Brynild needs to simultaneously consider other types of demand, each of which is forecasted and managed differently. The planning of new product launches will be further explained in the next section. In addition to the demand from new product launches, Brynild has to plan for regular demand. Regular demand corresponds to the demand of normal sales on already existing products, excluding campaign and seasonality. The demand from new product launches turns into regular demand when the launch period ends. Brynild uses an ERP system delivered by SAP. The ERP system calculates the forecasted regular demand based on the historical demand for each product. Statistical forecasting methods are used in the ERP system, and regular demand is usually forecasted 12 months ahead.

Brynild also needs to consider demand from campaigns. Campaign demand refers to the temporary increase in demand caused by promotional activity. Campaigns are planned with individual retail chains, and Brynild is usually informed of which stores that will execute the promotion. Brynild consults with the retail chain in question to determine the anticipated demand during the campaign. After reaching an agreement, Brynild typically delivers the agreed number of products within 4-6 weeks. Campaign demand will affect the demand for new product launches if there are campaigns during the launch period. The campaign demand is often forecasted manually and added to the ERP system.

Lastly, Brynild must consider the demand for seasonal products. Seasonal demand refers to increased product sales during holidays like Easter, Halloween, and Christmas. Seasonal demand is projected using historical data and added to the regular

---

demand to calculate the product's total expected demand. Since the demand during seasonal periods is many times higher than the off-season demand, it tends to be produced well ahead of the season in order to account for capacity constraints. Seasonal demand interferes with the demand for new product introductions when they move into season.

Brynild has weekly S&OP meetings to evaluate the total forecasted volume and typically operates with a planning horizon of 4-26 weeks. The following topics are frequently discussed in these meetings: what to prioritize, whether or not the sales and operations plan is achievable or requires modifications, shift arrangements, and the need for overtime.

The forecasted regular demand 12 months ahead is adjusted with the demand due to campaigns and seasons, as explained above. The ERP system then splits the forecasted demand into weekly demand resulting in a master production schedule (MPS) that shows the production needs for each production line for the next 52 weeks. For the MPS, the lot sizing is determined by the ERP system, prioritizing products with the highest volumes. The lot size is often set equal to the production output from one shift or based on a fixed length between each lot. Moreover, the master production schedule from the ERP system does not consider capacity. As a result, the planners do a rough-cut capacity planning, which is performed every other week during the S&OP meetings. Additionally, as the ERP system does not include functionality to plan for safety stocks or production sequence for each product, it is done manually by the planners at this stage. The planners try to level the production for the following 4-5 weeks, considering capacity, safety stock, and sequencing. As manual adjustments are made, the lot sizing decisions are changed as well. The manually adjusted master production schedule is then exploded based on material requirements planning with the bill of materials in the ERP system. The planners then determine a final detailed production plan and a capacity plan describing what products to produce, at what production lines, in what quantity, and on what days.

Brynild's production strategy is to be responsive so they do not freeze their production plans. New information is incorporated into the planning as soon as it is available. In order to be responsive to new information, there is a need for a buffer inventory of raw materials and packaging materials, usually bought from suppliers abroad. However, the production goal for sugar confectioneries is to minimize the setup time, as the drying cabinet is the limiting factor for these products.



---

## Planning of new product launches

The beginning of a new product launch happens within Brynild's board of innovation, where the decision about launching new products is made. Then, sales and operations planning (S&OP) meetings further discuss the launch of the new product. The volume estimates are based on an initial listing from the retail chains, typically received 2-3 months prior to launch. The initial listing contains information from the retail chains on the expected number of stores the product will be sold in, in addition to the placement in the stores. This information is then used to create a forecast of the demand for the first 2-3 months of the launch, usually manually by qualitative judgment. For line extensions, historical demand for already existing products within the same line is used as a reference for demand calculations. For brand new products, planners try to look at similar products within the same product category as a reference.

The production often starts 2.5 months prior to the launch, where the objective is to produce around 70% of the forecasted demand for the 3 months, based on the initial listing. The last 30% are considered closer to the launch date when the final listings are received from the retail chains, which is typically received within four weeks before launch. The reason for this approach is that there can be a difference between the initial listing and the final listing, meaning that the expected sales volume for the first part of the launch period can change. The remaining 30% can be produced if necessary should the final listing change prior to launch. The lot size is usually decided from a test production run, where the lot size is set to the output of one shift. The production plan is based on this lot size, but there are typically some uncertainties regarding the production output, making the inventory build up more critical. The 70-30 % method described is not fixed for each new product launch but varies based on qualitative decisions from production planners, varying from 60-40% to 80-20% depending on the product.

However, with the approach, the production of 70% of expected demand for the first 2-3 months creates an extensive inventory. The pipeline fill is made to ensure product availability during the initial launch period when demand uncertainty is high. As Brynild has a make-to-stock environment where the customer order decoupling point is located at the finished goods inventory, the service level relies on whether the finished product is in stock or not. As Norwegian wholesalers expect a service level of up to 97% and 2-3 days delivery time, Brynild is left with little room for late or partial orders. Therefore, the huge inventory containing 3 months' worth of expected demand is made to ensure that the required service level is achieved. If the products are not in stock, the order can be backlogged or considered a lost sale, depending on

---

the product. There is no discount on the products if the orders are backlogged, but the total service level is measured and used as a bargaining tool by the wholesalers.

The first indication of how well a new product is selling comes through a rapport from Nielsen, an analytical company. The Nielsen rapport is released every three weeks. Point of sales data from the last three weeks is aggregated and split on individual retailers. From the rapport, Brynild gains insights into how well the products are selling in the different retail chains.

## 5.2 Data cleaning and transformation

To perform our data analysis, we used data from one of Brynild's three primary wholesaler customers, NorgesGruppen. The reason for selecting data from NorgesGruppen was because we had access to more point of sales data from the associated retail stores of NorgesGruppen compared to that of COOP and REMA 1000. The following data were used in our analysis:

1. Point of sales data from stores of the retail chains associated with NorgesGruppen. The data includes sales of all of Brynild's products from 2016 to 2020.
2. Historical sales data from Brynild to NorgesGruppen's warehouses for each of Brynild's products. The data dates back to 2013, but data from 2016 to 2020 were used corresponding to the POS data.
3. Historical production data from 2016 to 2020 of Brynild's products

Section 2.2.2 gives a more detailed explanation of all the datasets that were made available for our research. Since the scope of our project is limited to new product introductions, the first step in our data cleaning process was to identify all of Brynild's new product introductions during the time period we had available POS data. In total, Brynild launched 156 new products between 2016 and 2020. Of the 156 new product launches, a significant number had to be excluded from our data analysis due to data insufficiencies. We made the following selection requirements for the different types of data:

### Point of sales data

- The product must have point of sales data recorded for the full duration of the launch period (26 weeks).

- 
- The point of sales data must start at a low-point, clearly indicating a new product launch and ensuring there are no unrecorded sales prior to launch.
  - The point of sales data must be continuous, showing no prolonged gaps without sales indicating missing data.

### **Production data**

- The product must have recorded production data.
- The product must have production data dated before the first recorded sale to NorgesGruppen of the given product, indicating no missing production pre-launch.

### **Sales data from Brynild to NorgesGruppen**

- The product must have recorded sales to at least one of NorgesGruppen's warehouses
- The product must have recorded sales dated before the first POS data, indicating no missing sales pre-launch.

### **General**

- Brynild's inventory should never fall below 0 for the duration of the launch period, meaning the sum of the production of a product should always be greater than or equal to the sum of sales out of Brynild.
- NorgesGruppen's inventory should never fall below 0 for the duration of the launch period, meaning the sum of the sales to NorgesGruppen should always be greater than or equal to the sum of POS sales in the stores.

In the end, 64 products passed all our selection requirements and were used as the basis for our data analysis.

## **5.3 Descriptive analysis**

This section presents a descriptive analysis of the 64 new products that passed the data cleaning requirements. The descriptive analysis is conducted to give the reader

---

a better understanding of the data and to justify model parameters selected later. New product launches are first examined before production, order, and point of sales data are analyzed descriptively.

### 5.3.1 New product launches

Figure 5.3 shows the distribution of the new products based on what year the product was launched, from 2016 until 2020. The figure shows that most new product launches included in the analysis were launched in 2017, 2019, and 2020, while only a few products from 2016 are used.

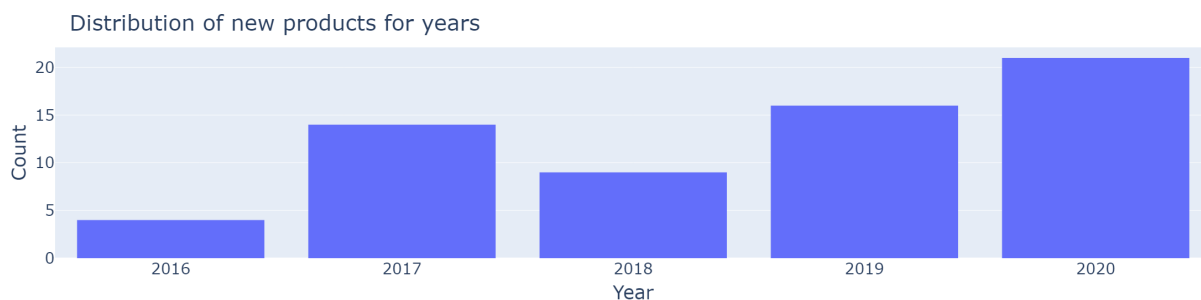

Figure 5.3: New product launches per year

New products can be introduced in grocery stores three times a year in Norway, as explained in section 5.1. Figure 5.4 shows in what period the products were launched, where launch period 1 corresponds with the launch window in February, launch period 2 is the launch window in May, and launch period 3 is in September. More than half of the new product launches in the analysis were released in February. As we have used a launch period of 26 weeks, the analysis of new product launches in period 1 will contain the Easter holidays. Similarly, the new product launches in period 3 will contain the Christmas holidays. Both holidays are periods with increased sales of Brynild’s products and can influence the analysis, especially when predicting the demand for the holiday weeks. Also, it is worth noting that the launch period of 26 weeks is likely to contain campaigns for the new product launches, which is not considered in the analysis.

Figure 5.5 shows how the new product launches in the analysis are distributed in different product categories. The product categories of the new product launches analyzed are sugar candy, pastilles, chocolate, and snack nuts, where a significant amount of new product launches are snack nuts. The noticeable amount of new snack nuts launches is that Brynild changed from pick and mix nuts to snack nuts sold in cups in 2020. This change resulted in many new product launches, particularly because some of the nuts were now sold in different cup sizes.

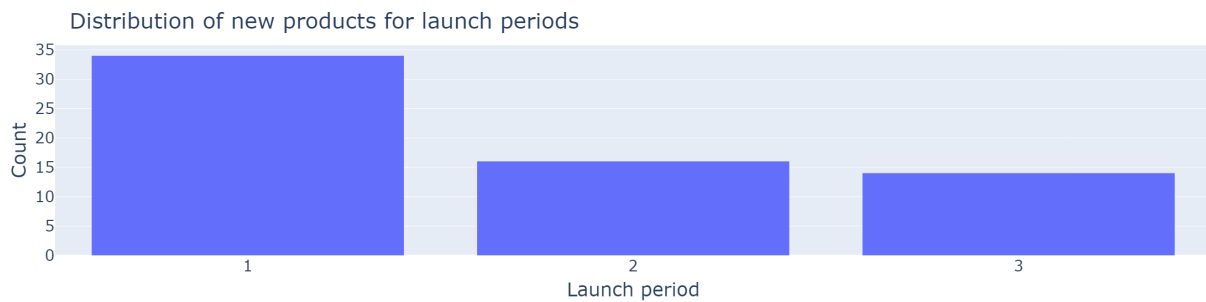

Figure 5.4: New product launches for each launch period

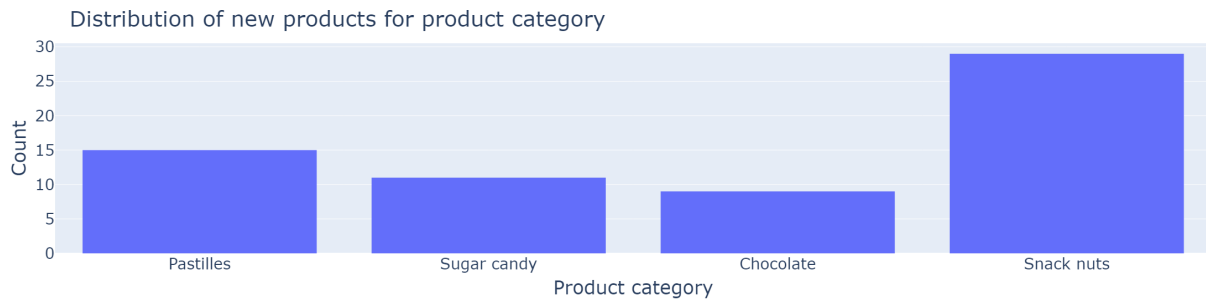

Figure 5.5: New products launches for each product category

When a new product is launched, Brynild operates with three sales solutions for selling the products to the wholesalers. The first sale solution is a "distribution packet" (D-pak), where multiple consumer packets (F-paks) are grouped into a unit and sold together. Secondly, Brynild uses a sales solution called "sales solution one product" (SL 1 variant), where multiple distribution packets (D-paks) of the product are sold together in a large quantity. Finally, "sales solution multiple products" (SL flere varianter) are used, where distribution packets (D-pak) from different products are combined. As a result, when Brynild launches a new consumer product, several new sales solutions can be created. The 64 new product launches used in this analysis resulted in 130 new sales solutions. Therefore, when analyzing the orders of new product launches, all sales solutions of the product have to be included.

Figure 5.6 shows the number of each sales solution for each product. The figure shows that most of the new product launches are included in 2 sales solutions, while a few have 3 or 4 sales solutions. 20 of the products are just sold as distribution packets (D-paks) and not in other sale solutions. Figure 5.7 shows the distribution of sales solutions. This figure shows that all 64 new product launches are sold in D-paks, while 24 of the sales solutions are "sales solution one product" (SL 1 variant), and 42 of them are "sales solution multiple products" (SL flere varianter).

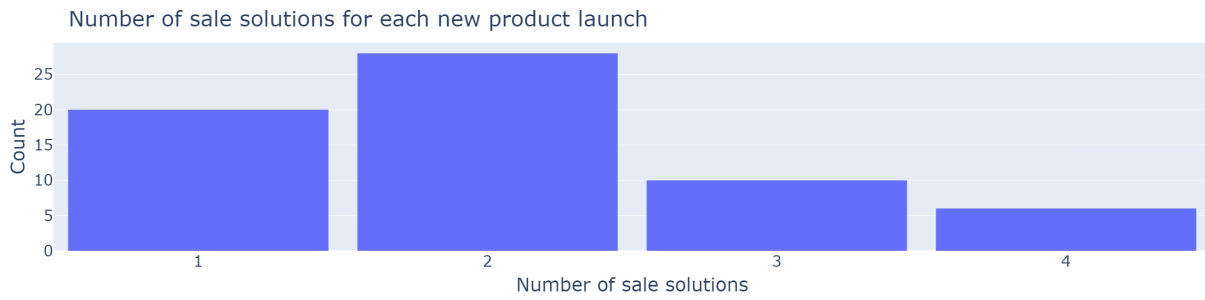

Figure 5.6: Number of sales solutions for each new product launch



Figure 5.7: New products for each sales solution

The following subsections provide further descriptive analysis on production and orders to NorgesGruppen, as well as point of sales data for the 64 new product launches. The descriptive statistics only consider the launch period of 26 weeks and production or orders prior to the launch date.

### 5.3.2 Production

Table 5.1 shows descriptive statistics for the production data of Brynild for the 64 new product launches. The table displays how many setups occur during the weeks when a product is produced. The mean value for all the 64 new product launches is 2 setups per production week, with a standard deviation of 0.6. Additionally, the table shows the number of setups per week for the duration of the launch period, giving a mean of 0.4 setups with a standard deviation of 0.3 setups. The descriptive statistics for the setups show that there are many weeks with no production, but multiple setups usually occur in weeks where there is production. The descriptive statistics on the setups will later be used to decide the capacity in terms of the number of setups per week.

Table 5.1 also shows pipeline fill length, representing the number of days before launch the production was initiated. It has a mean value of 46 days, with a standard deviation of 15 days. The maximum number of days was 82, while the minimum was

---

19 days prior, showing there is some variation in how early the production starts. Notice, however, that the production data only shows when the production of the new products is finished and not when the actual production starts. This could be a reason why the pipeline fill length is shorter than 75-90 days (2,5-3 months) as stated by Brynild for when they start producing the new product launches.

Further, the production quantity per production and per week in terms of consumer packages (F-paks) are shown in the table, and these numbers are scaled with the ratio of orders to NorgesGruppen. The scaling means that the production numbers shown are not the total production but the production that is estimated for NorgesGruppen. The production quantity per production day has a mean of 10796 F-paks and a standard deviation of 8201 F-paks, and the production quantity per week has a mean of 4468 F-paks and a standard deviation of 5045 F-paks. Additionally, we notice a difference between the minimum values and the maximum values for the two, indicating different production quantities for each new product launch. The production quantity per production will be used to set the daily production capacity in the dynamic lot sizing model. The production quantity per week provides an understanding of the weekly production size, which will be the output of the dynamic lot sizing model.

	<b>Setups per production week</b>	<b>Setups per week</b>	<b>Pipeline fill length (days)</b>	<b>Production quantity per production day (F-pak)</b>	<b>Production quantity per week (F-pak)</b>
<b>count</b>	64	64	64	64	64
<b>mean</b>	2.0	0.4	46	10796	4468
<b>std</b>	0.6	0.3	15	8201	5045
<b>min</b>	1.0	0.1	19	972	324
<b>max</b>	4.0	1.5	82	42939	31999

Table 5.1: Descriptive statistics of the production data for the 64 new products

### 5.3.3 Orders from NorgesGruppen

Table 5.2 display descriptive statistics for the orders from NorgesGruppen for the 64 new product launches. The mean value of the sales ratio to NorgesGruppen is 62% with a standard deviation of 28%. That means that on average, for the 64 products analyzed, 62% of sales was to NorgesGruppen. The minimum value of the sales ratio was 13%, and the maximum value was 100%, meaning for some products, all

---

orders were to NorgesGruppen. The mean value is higher than the overall market share of NorgesGruppen at 44%, as stated in 4.1, showing that the new products analyzed have higher sales to NorgesGruppen than the normal. As the sales ratio to NorgesGruppen varies for each new product launch, the scaled production can give wrong estimates. The new product launches with 100% sales to NorgesGruppen will have the right production amount in the database, but the rest must be scaled. The scaling of the production to correspond with the sales to NorgesGruppen can give wrong estimates and cause situations with negative inventory, as the magnitude of the scaling is wrong.

Additionally, table 5.2 shows the percentage of F-paks ordered in the sale solutions "SL 1 variant" or "SL flere varianter". The mean is 25%, and the standard deviation is 22%. The minimum value is 0 %, and the maximum value is 80%, showing that some of the new product launches are just ordered as D-paks, while others have much of the quantity ordered in the other sales solutions. This shows the importance of including all the sales solutions for each product in the analysis to get the total quantity right.

Further, the table shows the wholesaler fill quantity. This is the order quantity prior to the pipeline date, representing the quantity NorgesGruppen orders to fill up the stores. The mean value is 32984 F-paks with a standard deviation of 33478 F-paks. As the standard deviation is higher than the mean value, it indicates a big spread in the data. The wholesaler fill quantity is a quantity Brynild has to produce and can not be reduced by Brynild.

In addition, the table shows the order quantity per week, with a mean of 4205 F-paks, and a standard deviation of 4965 F-paks. Also in this case is the standard deviation higher than the mean. Further, as with the production, we see a big difference in the minimum value of 302 F-paks and the maximum value of 30336 F-paks showing some products are ordered in higher quantities. The order quantity per week represents Brynild's demand and will be used to calculate the deterministic dynamic lot sizing solution for each new product launch. Notice that the order data is aggregated for the 13 warehouses, and analyzing each warehouse alone could give more detailed insights into the ordering.



---

	NorgesGruppen sales ratio (%)	F-paks ordered as "SL 1 variant" or "SL flere varianter" (%)	Wholesaler fill quantity (F-pak)	Order quantity per week (F-pak)
<b>count</b>	64	64	64	64
<b>mean</b>	62	25	32984	4205
<b>std</b>	28	22	33478	4965
<b>min</b>	13	0	900	302
<b>max</b>	100	80	176880	30336

Table 5.2: Descriptive statistics of the order data for the 64 new products

### 5.3.4 Point of Sales at NorgesGruppen stores

Table 5.3 shows descriptive statistics for the point of sales data. From the table, we can see that the mean number of stores selling the new products is 940 stores, with a standard deviation of 426. The minimum number of stores was 76 stores, while the maximum was 1844 stores. We also see that the 64 new product launches have recorded point of sales data almost every day, with a mean of 98% and a standard deviation of 1%. The daily products sold per day are also shown, with a mean of 397 F-paks and a standard deviation of 474 F-paks. For daily products sold, the minimum value is 24 F-paks, and the maximum value is 3040. Further, we see that the mean number of F-paks sold per week in the launch period is 2692 F-paks, and the standard deviation is 3201 F-paks. As the point of sales data will be used to forecast the demand, it is important to understand the data. From the descriptive statistics, we see that most products have point of sales data each day, but the quantity per day varies. The number of stores selling the new product can impact the daily and weekly point of sales data. It is important to have enough data to get an accurate forecast. The point of sales data is aggregated for all stores, and investigating each store could give different information on the point of sales data.

---

	Number of stores selling the new product	Sales each day in the launch period (%)	Products sold per day in the launch period (F-pak)	Products sold per week in the launch period (F-pak)
<b>count</b>	64	64	64	64
<b>mean</b>	940	98	397	2692
<b>std</b>	426	1	474	3201
<b>min</b>	76	89	24	165
<b>max</b>	1844	100	3040	20498

Table 5.3: Descriptive statistics of point of sales data for the 64 new products

## 5.4 Model development

This section gives a description of the lot sizing model and three forecasting models used in the data analysis associated with the case study. It explains our reasons for choosing the selected models and the specifics of how they are designed and function.

### 5.4.1 Linear regression

A linear regression model (section 3.3.4) was chosen as one of the selected forecasting models. The reason for selecting a linear regression model was two-fold. Firstly, when conducting our literature study, we found that linear regression models are highly regarded in many studies because it is easy to implement, computationally inexpensive, and can produce satisfactorily accurate forecasts for real-world use (Gomila, 2021; Parmezan et al., 2019). Secondly, when performing descriptive data analytics, we observed that the cumulative sum of point of sales data resembled a linear line during the launch period of many of the products we examined. Figure 5.8 displays daily point of sales data and the cumulative sum of the point of sales data during the launch period for two of Brynild’s products. As can be seen in the illustration, the raw point of sales data itself does not resemble a linear line. Hence, our linear regression model struggled to find a linear correlation between daily raw POS data and future POS data. However, the cumulative sum of POS data does resemble a linear line, and was therefore regarded as well-fitted to be used for linear regression forecasting. Hence, we chose to include a linear regression model for our

---

case study.

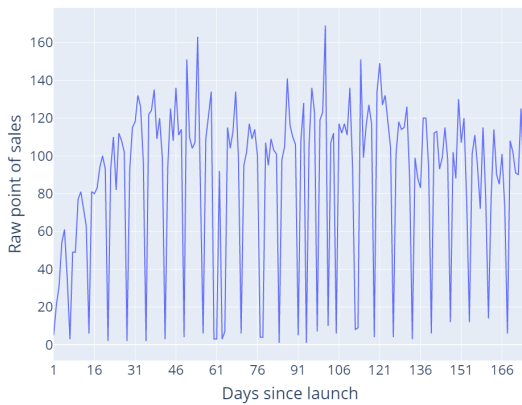

(a) Raw point of sales

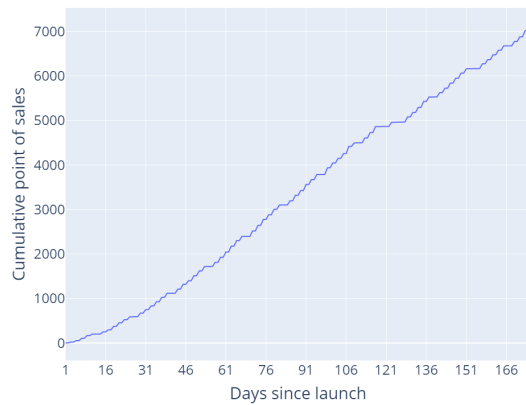

(b) Cumulative point of sales

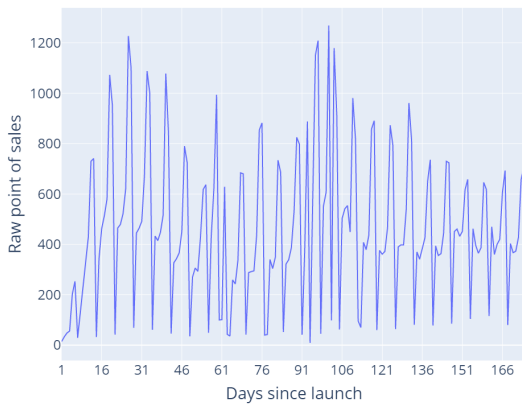

(c) Raw point of sales

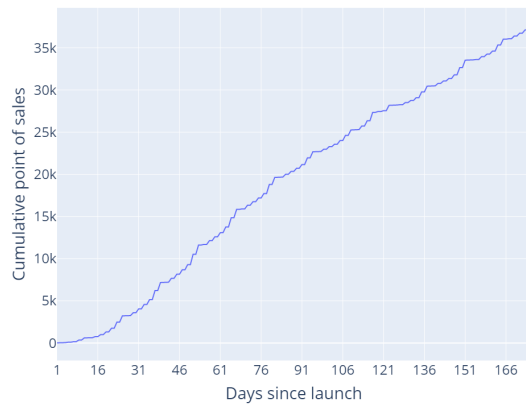

(d) Cumulative point of sales

Figure 5.8: Raw and cumulative point of sales data

## Data pre-processing

As we performed linear regression on the cumulative POS data, the first pre-processing step was to convert raw, daily POS data to the cumulative sum of POS data for all products. Figure 5.8 displays the transformation. The next step was to split the cumulative POS data into bulks of seven as the model was supposed to make a weekly forecast using all the data it had available to date. Figure 5.9 displays the input and expected output of the linear regression model.

---

$$input = \begin{bmatrix} [1, 2, \dots, 7] \\ [1, 2, \dots, 14] \\ \vdots \\ \vdots \end{bmatrix} \quad output = \begin{bmatrix} [8, 9, \dots, 34, 35] \\ [15, 16, \dots, 41, 42] \\ \vdots \\ \vdots \end{bmatrix}$$

Figure 5.9: Illustration of the data split: the arrays inside input and output illustrates POS observation at given days after launch

### Forecasting using linear regression

The only independent variable included in our model was previous POS data, hence the model was a single linear regression model depicted by Equation 3.11. At a weekly interval, the model was fed with all the POS data to date, which it used to calculate the optimal equation intercept and weights to obtain the best fitted regression line. The cumulative POS demand 28 days (4 weeks) into the future was estimated each week by inserting the 28 subsequent dates after the last recorded POS data into the regression equation. The predicted cumulative demand was then transformed into daily demand and aggregated to obtain the model's predicted weekly demand for the next 4 weeks. Figure 5.10 displays an example of the regression line calculated using 7 days and 14 days of POS data.

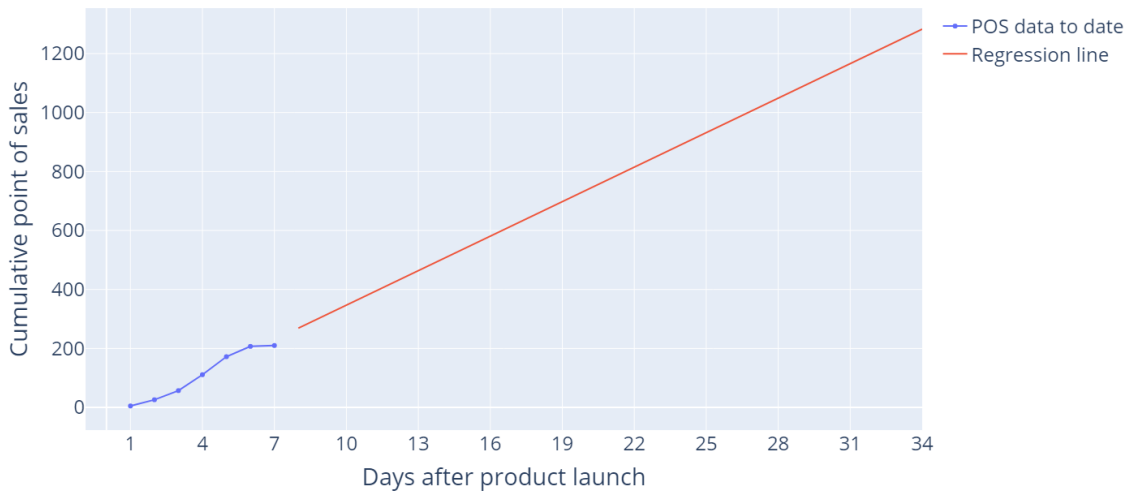

(a) Forecast after one week (7 days of POS data)

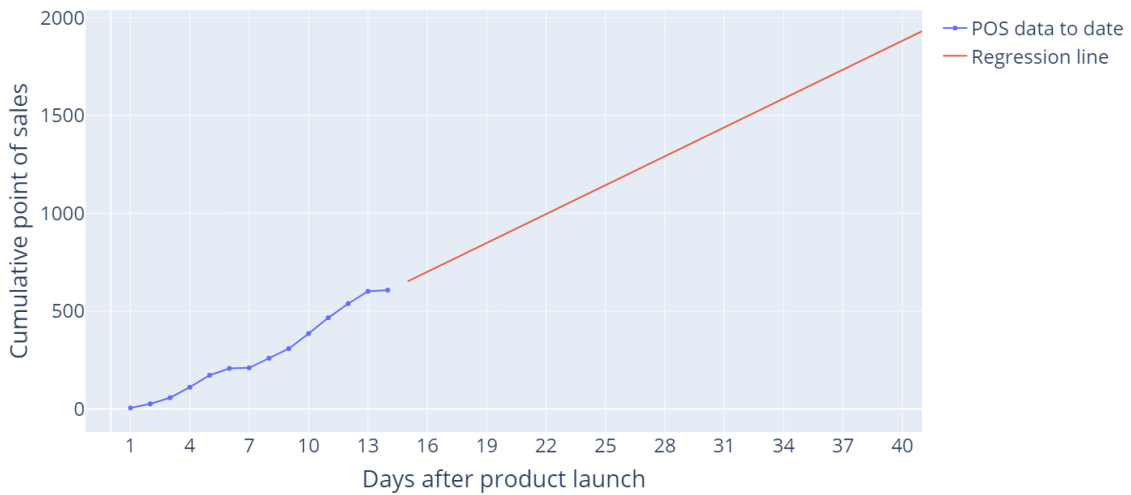

(b) Forecast after two weeks (14 days of POS data)

Figure 5.10: Linear regression forecasts after 7 and 14 days of POS data

### 5.4.2 Holt-Winters' model

The Holt-Winters' model (Section 3.3.5) was the second model implemented to perform forecasting on POS data. In our literature study on commonly used and state of the art forecasting methods, the Holt-Winters' method was one of the models that consistently performed well and proved robust on different data (Parmezan et al., 2019; Holt, 2004). Although the method is old, it is still consistently beating state of the art machine learning methods (Parmezan et al., 2019). A reason for this is that the Holt-Winters' model does not require loads of data in order to train and

---

forecast accurately, which is of particular importance in our case as we have no prior data for the new product launches and a limited number of total products to analyze. Additionally, the Holt-Winters' model is built to capture the seasonality and trend components in the data it forecasts, which is crucial in our case as the POS data have a clear weekly seasonal cycle (Figure 5.11). Another reason for selecting the method is because our case company Brynild is already using the method in their forecasts, although not for POS data. Therefore, it would be relatively simple for Brynild to implement the method on POS data should it give satisfactory results, as they have prior experience.

The Holt-Winters' method can be implemented with additive or multiplicative configurations (equations 3.14 and 3.16). The model configuration resulting in the lowest MAPE was with the additive trend and seasonal components, hence that is the one used for the results.

### **Data pre-processing**

Unlike the linear regression model, the Holt-Winters' model was able to forecast accurately on raw point of sales data. However, similar to the linear regression model the data was split into bulks of seven as the model was supposed to make a forecast every week. Splitting the data every week, starting on Monday, is suitable for our forecasting task as one seasonal cycle of POS data is naturally one week, as can be seen in Figure 5.11. The Holt-Winters' model was set to forecast 4 weeks into the future based on all point of sales data available at that time, as illustrated in Figure 5.9.

All POS observations were added by a unit of 1, because the Holt-Winters' multiplicative method can not function with values of zero due to the possibility of division by zero, as can be seen in Equation 3.17. An addition of a small unit such as 1 does not alter the scale of the observations significantly, hence it is a feasible solution for our task. That means, of course, that the predicted forecast values had to be subtracted by 1 to obtain the final forecasted demand.

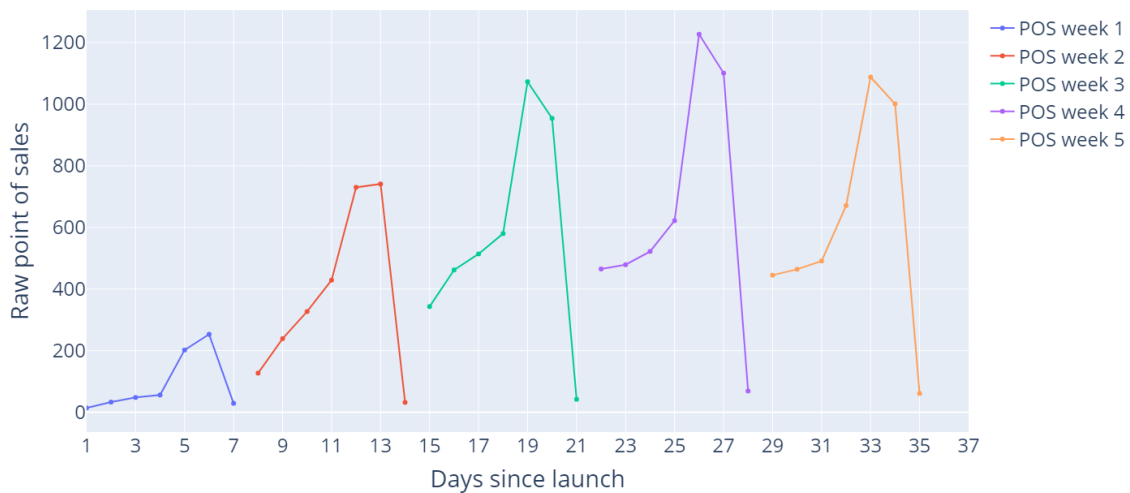

Figure 5.11: Seasonal POS data

### Forecasting using Holt-Winters' model

To find the optimal fit for the smoothing coefficients used in the Holt-Winters' equations, two full seasonal cycles are required. Therefore, the Holt-Winters' model could not be applied without alteration after the first week after launch when all that was available was 7 days of POS data corresponding to only a single seasonal cycle. Instead, simple exponential smoothing (equation 3.13) was used to forecast after the first week of recorded POS data. Simple exponential smoothing disregards seasonal and trend factors, and simply forecasts the expected level, as seen in Figure 5.12a.

For the remaining of the forecasts, the Holt-Winters' model was used. The prediction accuracy of additive and multiplicative model configurations (Equations 3.14 and 3.16) were compared to determine the optimal model configurations. The configuration with the lowest forecast error (MAPE, Equation 3.9) was with the additive trend and seasonal parameters.

Prior to prediction each week, smoothing coefficients were fitted on all the POS data available at that time. The model predicted 4 weeks ahead, as illustrated in Figure 5.12b.

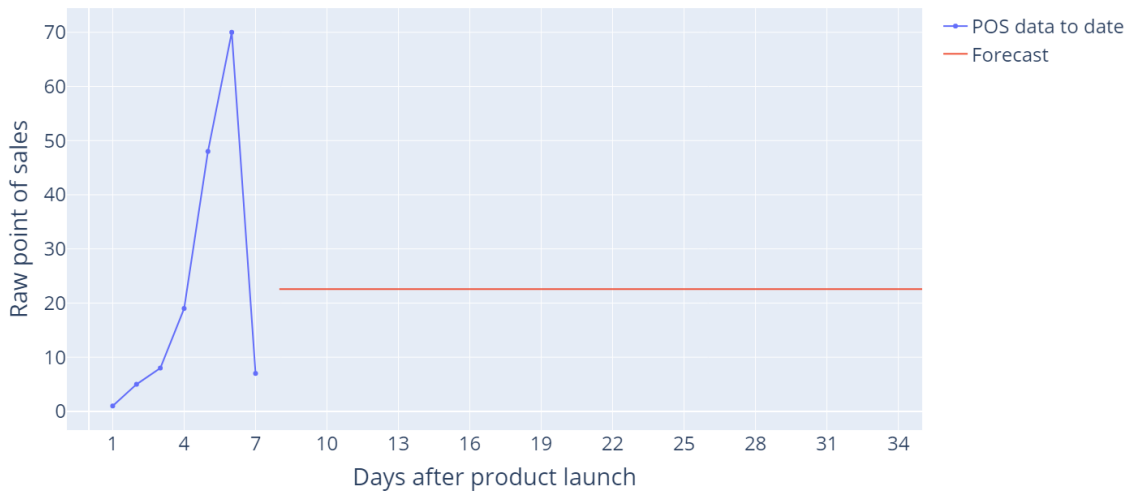

(a) Forecast after one week (7 days of POS data)



(b) Forecast after two weeks (14 days of POS data)

Figure 5.12: Holt-Winters forecasts after 7 and 14 days of POS data

### 5.4.3 Long-short term memory (LSTM) model

As discussed in Section 3.3.5, LSTM networks are one of the most prominent machine learning methods for time series forecasting. Our reason for selecting an LSTM network was due to its ability to capture the underlying sequential information in the input data. The ordered sequence that the point of sales data comes in contains information which is crucial to capture in order to perform accurate forecasting. LSTM networks are the machine learning method that proved most competitive with the state of the art statistical forecasting methods, according to most research



---

examined in our literature study. One of the most highly respected forecasting competitions is the Makridakis competition (Makridakis et al., 2018a). The competition has the intention to evaluate and compare different time-series forecasting methods. The winner of the M4 (Makridakis 4) competition was an LSTM model, showing that the model is state of the art within time-series forecasting.

### Data pre-processing

The data pre-processing steps required for the LSTM network are quite different from that of the linear regression and Holt-Winters models. Neural networks typically do not perform well when the attributes of the input data are in a different or spread numerical range (García et al., 2015). Therefore, normalization was performed to squeeze the input data into an interval. Our selected method of doing so was through min-max normalization. Min-max normalization squeezes the input data to a range between 0 and 1 while retaining the ratio between all data points. Each POS observation was passed through Equation 5.1 to calculate its normalized value  $y_{norm}$ :

$$y_{norm} = \frac{y - \min_A}{\max_A - \min_A} \quad (5.1)$$

where  $\min_A$  and  $\max_A$  refers to the minimum and maximum values of dataset  $A$ .

A neural network also requires a pre-defined input shape in order to learn a specific task. We wanted our models to be able to generate forecasts after the first week of POS data, hence we chose to feed 7 days of POS data as input to the LSTM network and made it forecast the next 28 days (4 weeks) into the future. The input and output data is illustrated in Figure 5.13.

$$input = \begin{bmatrix} [1, 2, \dots, 7] \\ [8, 9, \dots, 14] \\ \vdots \\ \vdots \end{bmatrix} \quad output = \begin{bmatrix} [8, 9, \dots, 34, 35] \\ [15, 16, \dots, 41, 42] \\ \vdots \\ \vdots \end{bmatrix}$$

Figure 5.13: Illustration of the data split: the arrays inside input and output illustrates POS observation at given days after launch

The POS dataset was split into a training, a validation, and a test set so that the LSTM network could train on a set of products, validate its accuracy on a validation set after each iteration of training, and finally test its prediction accuracy on an unseen test set after training. The training set consisted of 80% of the products,

---

the validation set consisted of 10% of the products, and the test set consisted of the remaining 10% of the products. That means that the test set, which forms the basis of the results, only consisted of 9 products.

## **Network configurations**

When building a neural network, it is crucial to test and select the model architecture and parameters best suited for the task it is meant to solve. We chose to test and select parameters for our LSTM network in the following order:

1. Network architecture
  - a. Number of layers and types of layers
  - b. Number of neurons in each layer
2. Loss function and optimizing algorithm
3. Hyperparameters
  - a. Batch size
  - b. Early stopping patience level

## **Network architecture**

Multiple network architectures were tested to find the one that yielded the highest prediction accuracy. A shallow LSTM network containing only a single LSTM layer was tested and compared with deep LSTM networks with multiple LSTM layers. The best performing model was a deep LSTM network containing two LSTM layers, and a standard feedforward output layer. To determine the number of neurons per layer, we followed the following common guidelines on node selection:

1. The number of nodes should be a geometric progression of 2, e.g. 2, 4, 8, 16 etc
2. Hidden layers should have half the number of nodes as the previous layer
3. The output layer should contain as many nodes as the number of days it is supposed to forecast

The resulting network contained two LSTM layers with 32 and 16 nodes respectively, as well as an output layer with 28 nodes corresponding to the 28 days (4 weeks) the network was supposed to forecast. Figure 5.14 illustrates the architecture of the LSTM network used in our data analysis.

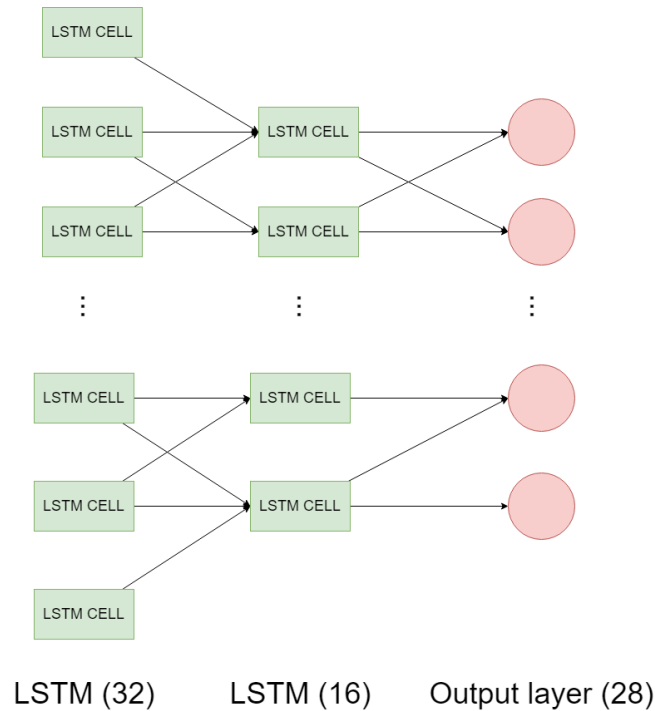

Figure 5.14: LSTM network architecture

### Loss function and optimizing algorithm

The loss function in a neural network is a function that calculates the deviation between the expected outcome and the predicted outcome produced by the machine learning model. From the loss function, we derive the gradients which are used to update the weights in the network. Prediction of point of sales data is a regression task where the expected and predicted values are real numbers, hence we selected a loss function optimized for regression settings. Mean squared error (MSE) was our selected choice for optimizing the algorithm (Equation 3.8).

An optimizing algorithm is an algorithm used to change the attributes of a neural network, such as weights and learning rate, in order to reduce the error calculated by the loss function. Thus it helps the network train efficiently and improves prediction accuracy. Similar to the loss function, the optimizing algorithm should be chosen according to the task at hand. The optimizing algorithm of choice for our data analysis is the Adaptive Moment Estimation (ADAM) optimizer. The ADAM

---

optimizer is regarded positively in much recent research on forecasting and regression analysis (Zhang, 2018), much due to its ability to generalize, fast run time, and low memory requirements.

### **Hyperparameter tuning**

Setting our hyperparameters had the goal of improving prediction accuracy, reducing training time, and avoiding overfitting. Because data was scarce, we used a batch size of 1, so the network could pull any prediction accuracy gains from every sample in our training dataset. Larger batch sizes of 8 and 16 were also tested without seeing any performance gains.

To prevent our model from overfitting on the training data, early stopping was used during training. Early stopping means that the network will stop training after when it gets no increase in prediction accuracy on the validation set. A patience level of 3 was selected such that the training would stop if no accuracy gains were measured in 3 subsequent epochs. The reason for a patience level of 3 was that we observed that the validation loss might increase for one or two epochs before dropping to a new low.

#### **5.4.4 Dynamic lot sizing models**

Two dynamic lot sizing models have been developed in the case study. Table 3.1 presented in the theory chapter is used to classify the two dynamic lot sizing models. The first model is deterministic and uses historical demand, whereas the second is a stochastic model which uses forecasted demand. All other variables are deterministic. Further, both models have a finite planning horizon with a discrete time scale, but the stochastic model is implemented with a rolling horizon approach, explained further later. Both models are single item models, only considering one new product launch at the time. Single item models are selected to reduce the complexity and to focus on the new product launches. Additionally, the models are single level models, where only the finished products are analyzed. This means that they do not consider the production of intermediates and assume that these can be created within the time period of one week. Holding costs and setup costs are the costs considered in both models, and production costs are neglected. Further, both models are capacitated with production restrictions, with a limited production capacity for each period. As for the service level, the models operate with lost sales, and these will not be backlogged. However, service levels will be measured outside of the

---

models for comparison. No time consuming activities are considered in the models, and production and setup times are assumed to happen instantly. The objective of both models is to minimize the total costs of setup costs and holding costs. The two dynamic lot sizing models have been formulated as Mixed Integer Linear Programming (MILP) models in Gurobi and solved with the Gurobi optimizer (Gurobi Optimization, LLC, 2022).

### Assumptions and variable calculations

The data gathered from Brynild provides information about the production, orders out of Brynild, and point of sales in stores. However, some relevant information has not been explicitly given in the data. As a result, some assumptions and calculations from the data are made and used in the dynamic lot sizing models. The list below elaborates on the assumptions and the calculation of the variables which is made for each new product launch.

- (a) **Pipeline date.** We have assumed that the pipeline fill continues until after the first week of point of sales data is recorded. Since the point of sales data starts on a Monday, the pipeline date is the next Monday after the first point of sales sale. The lot sizing models only consider the period after the pipeline date and until the end of the launch period.
- (b) **Launch period length.** In the analysis, we have defined the launch period to last 26 weeks in total from the first recorded POS data. The reason for selecting 26 weeks is based on the results from Flaarønning and Løvhaugen (2021), where the authors showed that the point of sales data took up to 23 weeks to stabilize for some new product launches.
- (c) **Lead time.** The analysis assumes that each new product launch can be produced within a week, having a lead time shorter than a week for the final product.
- (d) **Ratio of sales to NorgesGruppen.** The data on orders out of Brynild contains orders from all of Brynilds customers. The rest of the data, like point of sales, only contains data on one of Brynild's customers, namely NorgesGruppen. The ratio of sales to NorgesGruppen has been calculated and used to scale the production. The ratio of sales to NorgesGruppen multiplied by the production is assumed only to give the production meant for NorgesGruppen, and is calculated for each new product launch. Table 5.2 shows descriptive statistics for the ratio.

- 
- (e) **Holding cost.** Brynild has no data on the holding cost, so the holding costs have to be calculated. Firstly, we make assumptions about the holding cost rate. As we have no data on the production costs, 80% of the median sales price of each product is used to estimate the cost of goods sold. Further, we assume that the holding cost rate is equal to 30% of the cost of goods sold. As we use a weekly holding cost rate, the holding cost rate is divided by 52. The weekly holding cost is calculated by multiplying the weekly holding cost rate with the inventory carried over to the next week.
- (f) **Setup cost.** The data sets do not contain information about the setup costs. Therefore, the setup cost per setup has been assumed to be 1050 NOK per setup. The assumption is based on conversations with Brynild, where the assumption includes having three workers working on the production line with each a personnel cost of 350, giving  $3 \cdot 350 = 1050$  NOK as the setup cost per setup. We do not consider sequence-dependent setup costs.
- (g) **Production capacity per setup.** The production capacity per setup is calculated using the average production quantity per production day for each new product launch. The production has also been scaled with the ratio of sales to NorgesGruppen. Table 5.1 showed descriptive statistics for the variable, providing an understanding of the size.
- (h) **Starting inventory.** The starting inventory of Brynild for a given product is calculated by subtracting the wholesaler fill from the pipeline fill for that product.
- (i) The pipeline fill quantity is calculated as the sum of the production quantity before the pipeline date. It has been scaled by the sales ratio to NorgesGruppen to estimate the pipeline fill produced to NorgesGruppen.
  - (ii) The wholesaler fill quantity is calculated as the sum of the order quantity prior to the pipeline date.
- (i) **Setup function.** Data on setups have not been given in the datasets. We have assumed that the production of a product on the same date is all from one setup. From the data, we have calculated *setups per production week* showing the mean number of setups the weeks there is production, and *setups per week* showing the mean number of setups for all weeks. These calculations are used to estimate the number of setups per week. Table 5.1 shows descriptive statistics for the variables. The mean number of setups per week was 0.43, and the mean number of setups per production week was 2.02. These mean values have been used to assume the setup capacity per week. As our dynamic

---

lot sizing models are single item, we have constrained the model to only allow 1 setup per week. We get the following setup function:

$$\delta(t) = \begin{cases} 0 & \text{if } x_t = 0 \\ 1 & \text{if } x_t > 0 \end{cases} \quad (5.2)$$

where  $\delta(t)$  refers to whether there is a setup in week  $t$ , and  $x_t$  refers to the production in week  $t$ .

(j) **Safety stock level.** The safety stock level has been assumed, and it is set equal to the production capacity per setup. As this is equal to the weekly capacity constraint, the service level reflects the maximum production during a week.

(k) **Service level.** The service level is calculated outside of the lot sizing model, from the resulting output. Equation 5.3 shows how the service level ( $sl$ ) is calculated for each new product launch, where  $ls$  is the total quantity not in stock, and  $d$  is the total quantity demanded. The service level is calculated for all lot sizing models

$$sl_i = 1 - \frac{\sum_{t=1}^T ls_i}{\sum_{t=1}^T d_i} \quad (5.3)$$

### The deterministic model with historical demand

For the deterministic model, the demand used is historical data for the new product launches. It is considered deterministic as the values are known. Table 5.4 shows the variables used over the period from 1 to  $T$ , where  $T$  is the number of weeks in the launch period set equal to 25 weeks, as assumption (a) explained.

The objective function is given by equation 5.4, where the sum of holding costs and setup costs are minimized.

$$\text{Minimize } \sum_{t=1}^T s_t \cdot \delta(x_t) + h_t \cdot I_t \quad (5.4)$$

Subject to:

$$I_{t-1} + x_t = d_t + I_t \quad \forall t \in T \quad (5.5)$$

$$I_t, x_t \geq 0 \quad \forall t \in T \quad (5.6)$$

$$x_t \leq cap_t \quad \forall t \in T \quad (5.7)$$

---

Variable	Explanation	Type	Variable calculation from the list
$d_t$	demand in period $t$	Input	Historical data
$h_t$	holding cost per item carried from period $t$ to period $t + 1$	Input	(e)
$s_t$	setup cost in period $t$	Input	(f)
$cap_t$	capacity for period $t$	Input	(g)
$I_0$	starting inventory	Input	(h)
$\delta(x_t)$	setup for period $t$	Decision	(i)
$I_t$	inventory at the end of period $t$	Decision	
$x_t$	products produced in period $t$	Decision	

Table 5.4: Variables in the deterministic dynamic lot sizing model for each new product launch

Constraint 5.5 is the inventory balance, and restriction 5.6 makes sure that the production and inventory are positive values. The capacity constraint is given by equation 5.7, showing that the production has to be lower than the production capacity.

### The stochastic model with forecasted demand

The stochastic model with forecasted demand is very similar to the deterministic model. Both models have the same objective function. The main difference is that the stochastic model uses forecasted demand as input rather than the actual demand. The stochastic model has the same variables as the deterministic model above, but with one extension, the safety stock, shown in Table 5.5. The main reason for adding the safety stock is to ensure a satisfactory service level. If the forecasted demand is significantly lower than the actual demand, the total costs will most likely be lower than the deterministic solution, but the service level will be lower as well. The safety stock is added as a restriction in the model, given by equation 5.8. The restriction puts a lower bound on the inventory, so the inventory level is always greater than the safety stock.

$$I_t \geq ss_t \quad \forall t \in T \quad (5.8)$$

The other main difference between the deterministic and stochastic models is that the stochastic model is implemented with a rolling horizon. Each week, the demand for the next four weeks is forecasted. The four weeks are then used as input to the stochastic model, where the model will find a solution over the 4-week period.



---

Variable	Explanation	Type	Variable calculation form the list
$d_t$	demand in period $t$	Input	Forecasted data
...	...	...	...
$ss_t$	safety stock in period $t$	Input	(j)

Table 5.5: Additional variables in the stochastic dynamic lot sizing model for each new product launch

Only the suggested production for the first week will be executed before the model receives four new weeks of forecasted demand with updated POS data as input. Algorithm 1 below shows the pseudocode for the rolling horizon implementation.

---

**Algorithm 1** Dynamic lot sizing with rolling horizon

---

```

1: procedure ROLLING HORIZON
2:    $results \leftarrow$  empty list
3:    $N \leftarrow$  length of  $launchPeriod$ 
4:   for  $i \leftarrow 1$  to  $N$  do
5:      $forecast \leftarrow$  runForecast( $i, i+4$ )
6:      $fourWeeksResult \leftarrow$  runLotSize( $forecast$ )
7:      $firstWeek \leftarrow$  fourWeeksResult[0]
8:      $results.append(firstWeek)$ 
9:   end for
10:  return  $results$ 
11: end procedure

```

---

### Dynamic lot sizing models with pipeline reduction

The dynamic lot sizing models described above are also tested with a pipeline reduction. Only the period after the pipeline date is considered by the lot sizing models. However, in order to investigate the period prior to the pipeline date, the production before the date is reduced. This means that the models above have a changed starting inventory, given by assumption (h). The reduction is made by reducing each production by a given percentage without shifting the dates of the productions. As a result, the setups prior to launch are the same as before, but the production quantity per setup is reduced such that the starting inventory, assumption (h), is close to zero.

---

## 5.5 Results

This section presents the results of the data analysis. The results are split three-fold: Firstly, the forecast accuracy of our proposed forecasting models is shown. Secondly, the costs and service levels obtained by using the forecasts from our proposed forecasting methods in a dynamic lot sizing model are compared to Brynild’s approach and the deterministic solution. For this comparison, Brynild’s pipeline fill is not altered. Finally, we compare the costs and service levels obtained by our three dynamic lot sizing models with a reduction of Brynild’s initial pipeline fill.

### 5.5.1 Forecasting models

We used mean absolute percentage error (MAPE, equation 3.9) to measure the forecast error of our forecast methods. The MAPE was calculated individually for each of the four weeks in the forecast horizon. Table 5.6 presents the error for each forecasting method.

	<b>MAPE 1 week</b>	<b>MAPE 2 weeks</b>	<b>MAPE 3 weeks</b>	<b>MAPE 4 weeks</b>	<b>Average MAPE</b>
<b>Linear regression</b>	110%	42%	45%	46%	60.8%
<b>Holt-Winters</b>	25%	38%	49%	62%	43.5%
<b>LSTM</b>	97%	86%	88%	88%	89.8%

Table 5.6: Forecast errors for each week ahead forecasted, measured in MAPE

### 5.5.2 Dynamic lot sizing models

The forecasts from each of our three forecasting models were used as input in the stochastic dynamic lot sizing model, resulting in a proposed production schedule during the launch period for each product analyzed. Similarly, actual order data to Brynild was used as input to the deterministic lot sizing model to create the deterministic production schedule. In addition, Brynild’s current approach has been calculated based on historical data on production and sales orders. Table 5.7 shows the service level descriptively. Figure 5.15, 5.16, and 5.17 illustrates the setup, holding, and total costs resulting from producing the proposed production plans

compared to the deterministic solution and Brynild’s approach. These figures visualize the costs with box plots. Note that the solution using forecasts from the LSTM network only considers the nine products in its test set (Section 5.4.3), so it is not as comparable to Brynild’s solution as the other models.

The service level for each of the solutions was measured and is displayed in Table 5.7. Brynild’s approach has the lowest average service level of 97.07% and the highest standard deviation of 8.91%. The deterministic lot sizing model has a service level mean of 100% with a standard deviation of 0.00%, meaning it was 100% for all. However, the model found 63 solutions, meaning the model did not find a solution for 1 of the new product launches. All forecasted solutions had an average service level above the required 97%. Additionally, the standard deviation was relatively low, and very few products fell below the 97% level. The solutions with LSTM forecasts as input had the best service level with a mean of 99.41% and a small standard deviation of 1.66%. Notice, however, that the LSTM considered only 9 new product launches, and 8 solutions were found. The service level with forecasts from the Holt-Winters’ method had a mean of 98.85% and a standard deviation of 3.15% based on the solution of 60 new products. The linear regression model gave the worst service level of the stochastic solutions with a mean of 97.81% and a standard deviation of 5.99%. However, using linear regression, the lot sizing model found 61 solutions, and the service level is still higher than Brynild’s current approach. The table also shows that the minimum service level was 68.60% using the linear regression solution, while it was 85.30% using Holt-Winters’ and 95.30% using the LSTM solution.

	<b>Brynild’s approach</b>	<b>Deterministic solution</b>	<b>Linear regression</b>	<b>Holt-Winters</b>	<b>LSTM</b>
<b>count</b>	64	63	61	60	8
<b>mean (%)</b>	97.07	100.00	97.81	98.85	99.41
<b>std (%)</b>	7.91	0.00	5.99	3.15	1.66
<b>min (%)</b>	61.97	100.00	68.60	85.30	95.30
<b>max (%)</b>	100.00	100.00	100.00	100.00	100.00

Table 5.7: Service levels

Holding cost results are illustrated in Figure 5.15. The figure shows that the holding cost of Brynild’s approach has a mean value of 143k NOK. The holding cost resulting from the deterministic solution is significantly lower, averaging at 68k NOK. The three stochastic solutions have a mean of 90k NOK, 94k NOK, and 38k NOK for

the linear regression, Holt-Winters, and LSTM, respectively, but the LSTM has considerably fewer observations. These costs are lower than Brynild's approach yet somewhat higher than the deterministic solution.

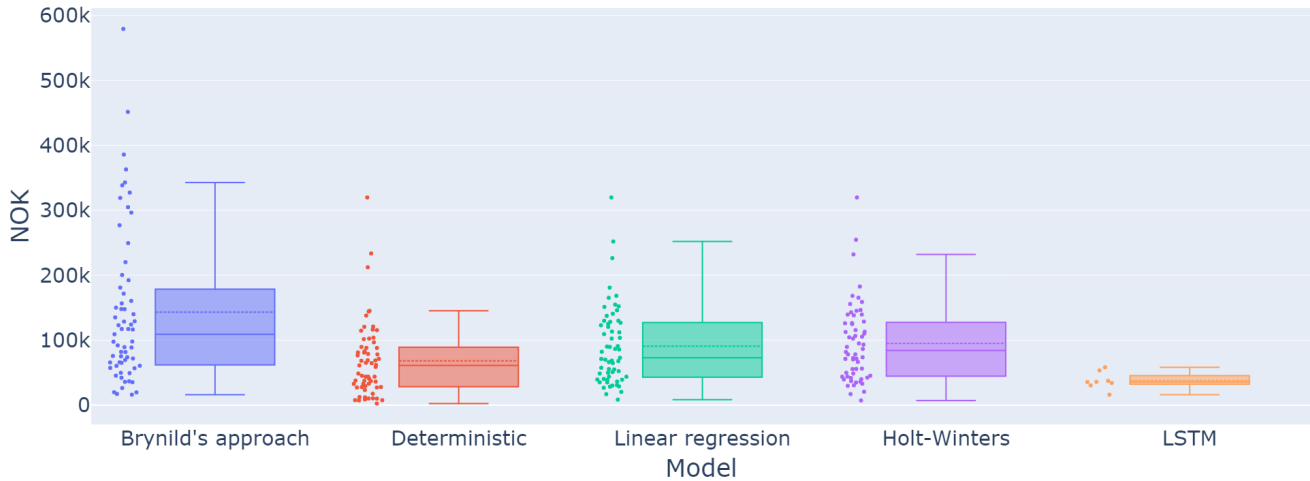

Figure 5.15: Holding costs

The setup costs, displayed by Figure 5.16, show that the mean is slightly higher in our forecasted solutions compared to Brynild's approach, except for the LSTM model. The deterministic solution has a marginally lower setup cost than Brynild, although with a higher standard deviation. The mean values vary from the highest for Holt-Winters with 15.2k NOK to the lowest for LSTM with 12.5k NOK. As the setup cost was set to 1050 NOK per setup, the mean values in terms of the number of setups vary between 14 to 12, showing that all the models have a very similar number of setups. The figure also shows a big spread in setup costs, indicating that some products are produced in higher volumes than others and require far more setups than others.

Figure 5.17 shows the total costs, calculated by summarizing the setup and holding costs. When comparing the setup cost and the holding cost, the holding cost dominates and is notably higher than the setup cost. Therefore, the significant reduction in holding cost is the reason why all solutions also have a lower average total cost than that of Brynild, despite having slightly higher setup costs. Brynild has a mean total cost of 158k NOK, while the deterministic solution has a mean of 82k NOK. The three stochastic solutions have a mean value between Brynild's approach and the deterministic solution with mean values of 106k NOK for linear regression, 110k NOK for Holt-Winters, and 78k NOK for LSTM. The average total cost of the LSTM model is lower than the deterministic due to the scarcity of observations.

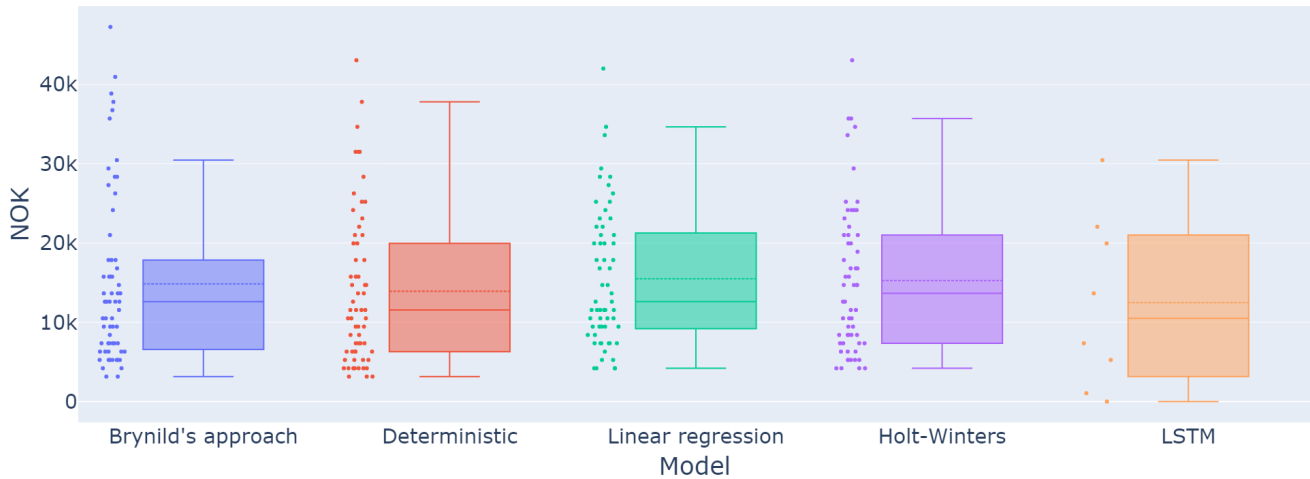

Figure 5.16: Setup costs

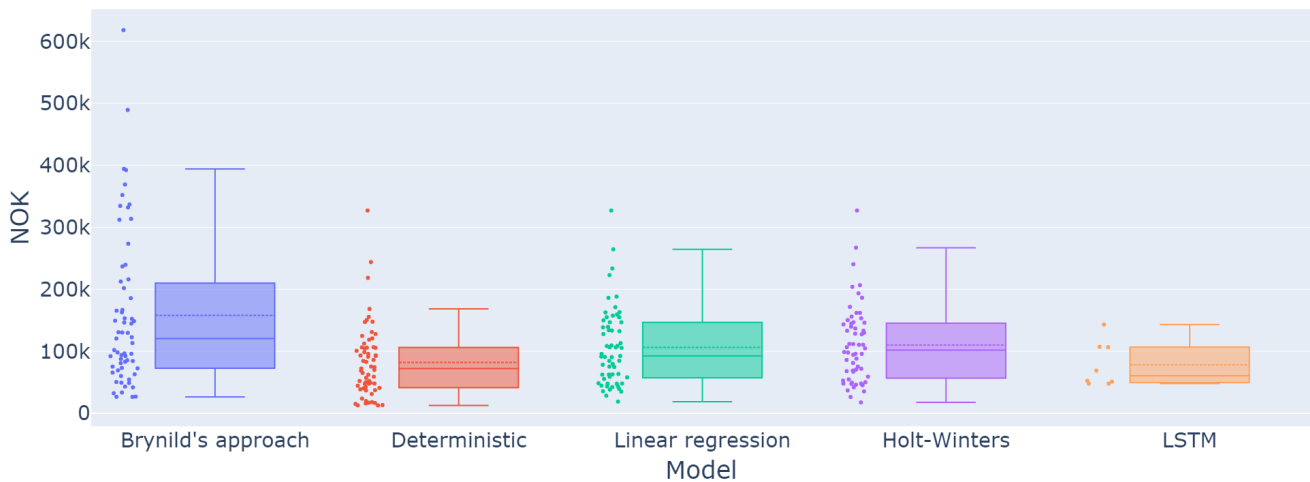

Figure 5.17: Total costs

### Comparing cost reduction

Table 5.8 displays the reduction in holding, setup, and total costs of the deterministic and three forecasted solutions in percentages in relation to Brynild's approach. The final average reduction is calculated by averaging the percentage reduction obtained for each individual product. As an example, since the LSTM solution only have 8 solutions, the final reduction is calculated by averaging the reduction compared to Brynild's approach for those 8 products. The holding cost is reduced for all forecasted solutions ranging from a 15.7% to 23.0% reduction. It is, however, still far away from the deterministic solution with a reduction of 47.2%.

The setup cost is slightly higher for all forecasted solutions, displayed in the table

as negative numbers. All stochastic solutions have a similar increase in setup cost of around 12%. In contrast, the setup costs are lowered for the deterministic solution by 6.2%.

The total cost of the deterministic solution gave a 41.1% reduction, as it reduced both holding costs and setup costs. The total cost is also lower for all stochastic solutions with forecasted demand. As the setup cost increased, the total costs were not reduced as much. The linear regression model had a cost reduction of 14.7% compared to Brynild’s approach. With forecasted demand from the Holt-Winters, the total cost reduction was 11.9%, giving the lowest reduction. The LSTM model, on the other hand, had the most considerable reduction in total costs averaging at 16.7%. However, the reduction for the stochastic solutions is below half the reduction for the deterministic solution.

	<b>Holding cost reduction</b>	<b>Setup cost reduction</b>	<b>Total cost reduction</b>
<b>Brynild’s approach</b>	-	-	-
<b>Deterministic solution</b>	47.2%	6.2%	41.1%
<b>Linear regression</b>	19.3%	-11.7%	14.7%
<b>Holt-Winters</b>	15.7%	-11.6%	11.9%
<b>LSTM</b>	23.0%	-12.9%	16.7%

Table 5.8: Comparing costs and service level of deterministic and stochastic solutions to Brynild’s current approach

### 5.5.3 Dynamic lot sizing models with pipeline reduction

The dynamic lot sizing models were also tested with a reduction in pipeline fill, meaning the models had a starting inventory close to zero. The average pipeline cut percentage was 41.7%, resulting in a 59.67% reduction in starting inventory on average. When comparing the stochastic results with pipeline reduction, we don’t alter Brynild’s approach to include the pipeline reduction as well. However, the pipeline reduction is performed for the deterministic dynamic lot sizing model. Table 5.9 show the resulting service levels while figures 5.18, 5.19, and 5.20 shows the setup, holding, and total costs derived from the models with a pipeline reduction.

The service levels with a pipeline reduction are presented in Table 5.9. Brynild’s

approach has the same service level as before, with a mean of 97.07% and a standard deviation of 7.91% for all 64 new product launches. The deterministic lot sizing model has a service level mean of 100% with a standard deviation of 0.00%. However, the deterministic model only found a solution for 58 of the 64 products. The stochastic model with forecasted demand using linear regression found 61 solutions, resulting in a mean service level of 96.41% and a standard deviation of 7.00%, the lowest mean and highest standard deviation of the stochastic solutions. Using forecasts from the Holt-Winters' method gave a mean service level of 97.56% with a standard deviation of 4.42% for 59 new products. Lastly, with LSTM, the service level was very high at 99.47%, having a standard deviation of 1.60%, and finding a solution for 8 out of 9 new product launches it examined. All stochastic solutions have a service level above 96%, and only the linear regression solution has a worse service level than Brynild's approach.

The service levels with pipeline reductions have a slightly lower mean and a higher standard deviation compared to the service levels without pipeline reductions. However, the change is small, and a satisfactory service level was sustained despite reducing the starting inventory. However, the deterministic and stochastic solution using Holt-Winters found fewer solutions with the pipeline reduction.

	<b>Brynild's approach</b>	<b>Deterministic solution</b>	<b>Linear regression</b>	<b>Holt-Winters</b>	<b>LSTM</b>
<b>count</b>	64	57	61	59	8
<b>mean (%)</b>	97.07	100.00	96.41	97.56	99.47
<b>std (%)</b>	7.91	0.00	7.00	4.42	1.60
<b>min (%)</b>	61.97	100.00	65.60	81.40	95.20
<b>max (%)</b>	100.00	100.00	100.00	100.00	100.00

Table 5.9: Results for service level after pipeline reduction

Figure 5.18 shows the holding costs for the 5 models investigated with a pipeline reduction. As can be seen from the figure, the deterministic solution is significantly lower than Brynild's approach. Brynild's approach gives a mean value of 143k NOK, while the deterministic with the pipeline reduction has a mean value of merely 21k NOK. In addition, the holding costs of the three stochastic models are noticeable lower than Brynild's current approach, although higher than the deterministic. The linear regression model and the Holt-Winters have a mean value of 55k NOK and 60k NOK, respectively. The LSTM, with far fewer solutions, has a mean of 35k NOK. As opposed to Brynild's approach, there are no significant outliers in the

---

holding cost of the stochastic models, indicating a lower standard deviation.

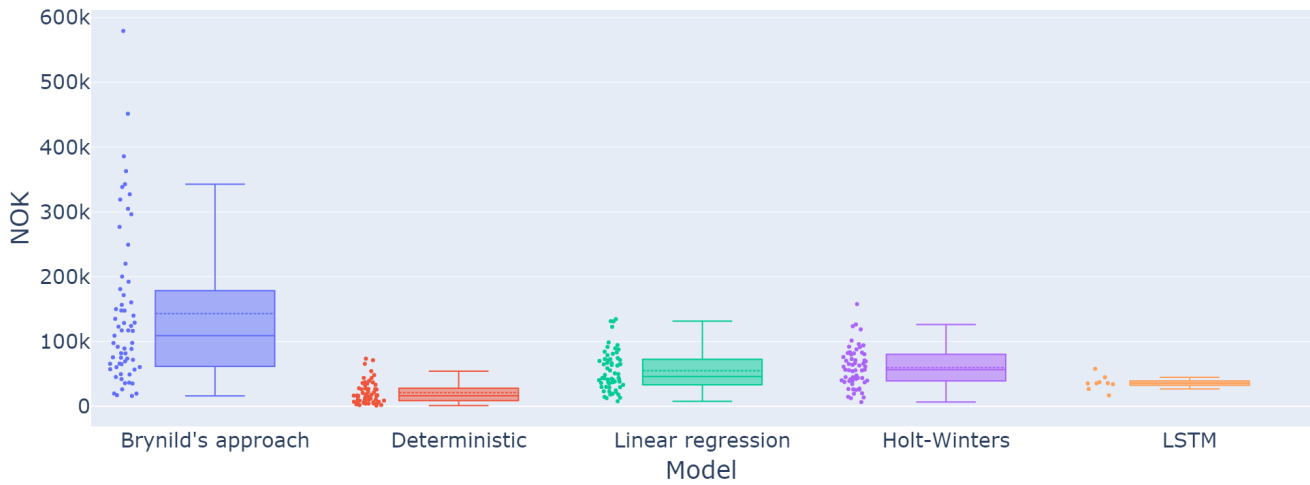

Figure 5.18: Holding costs with pipeline reduction

A comparison of setup costs with a pipeline reduction is illustrated in Figure 5.19. As can be seen in the figure, Brynild's approach and the deterministic solution have very close mean values for the setup cost. The model with forecasted demand using linear regression and Holt-Winters are a bit higher, while the mean for the solution using LSTM is the lowest of all, but also has the fewest observations. The mean setup cost varies from 12.7k NOK to 19.2k NOK, corresponding to a variation in the number of setups between 12.0 and 18.2 setups. The box plots for all models display a big spread, showing that the setups vary from product to product.

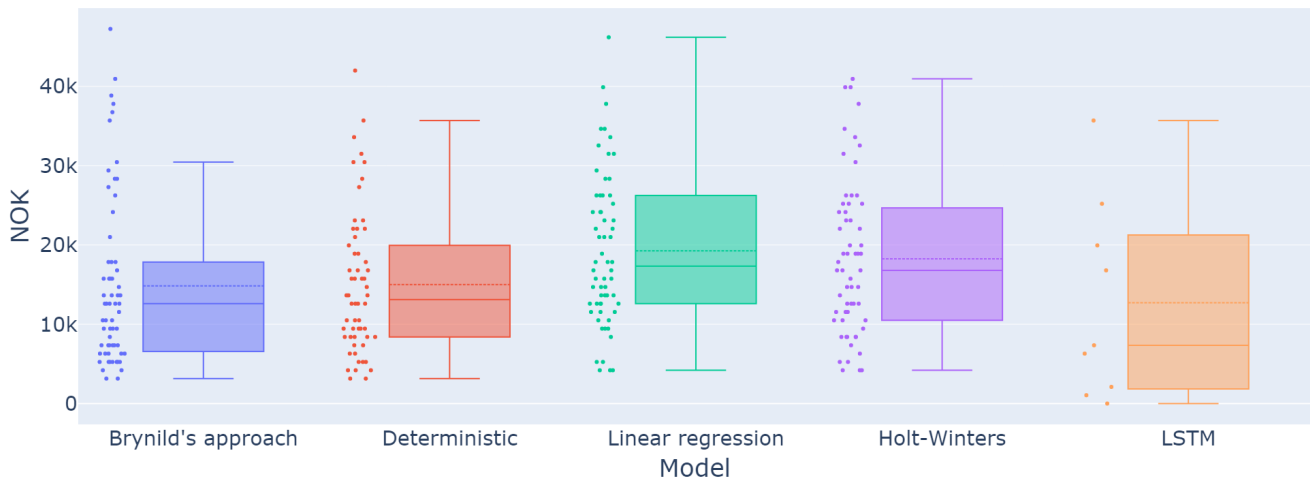

Figure 5.19: Setup costs with pipeline reduction

The total costs associated with a pipeline reduction are presented in Figure 5.20. Compared to Brynild's approach, all models have significantly lower total costs.



The total cost of Brynild’s approach has a mean value of 158k NOK, while the deterministic solution has a mean of only 36k NOK. After a pipeline reduction, all three stochastic models have similar total costs, which are noticeably lower than Brynild’s approach yet higher than the deterministic solution. The linear regression model has a mean total cost of 74k NOK, Holt-Winters has a mean of 81k NOK, and 67k NOK is the mean for the LSTM model. The pipeline reduction has reduced the standard deviation of the total costs, as can be seen in the box plot.

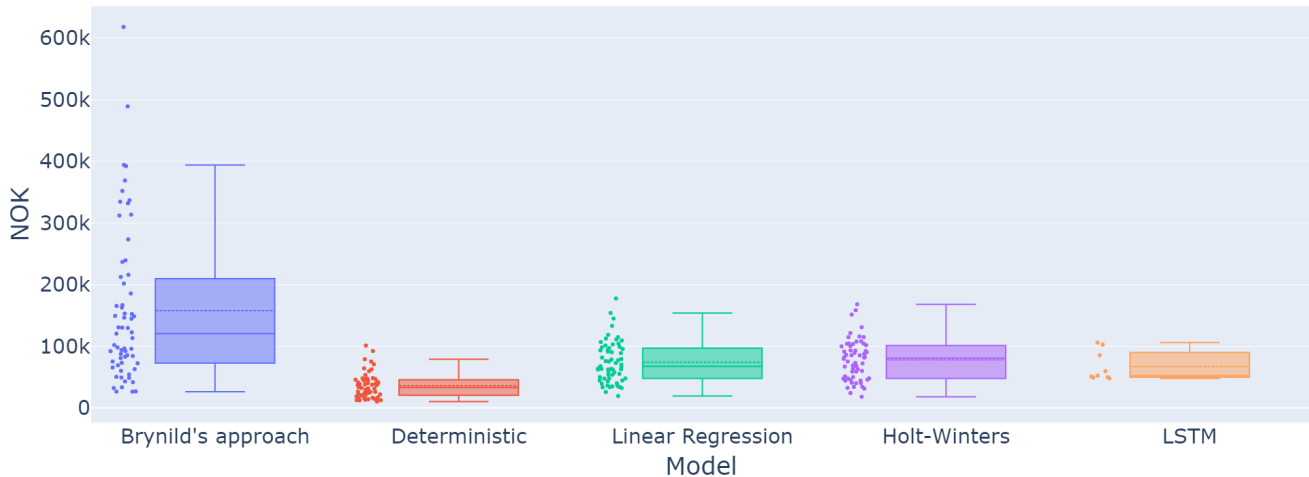

Figure 5.20: Total costs with pipeline reduction

### Comparing cost reduction

A comparison of cost reduction in percentages to Brynild’s approach with the pipeline reduction is displayed in Table 5.10. The deterministic solution has reduced the holding costs by 78.4%, while the reduction for the three stochastic solutions varies between 30.9% and 43.0%. The holding cost with a pipeline reduction is significantly lower than without the pipeline reduction.

Despite a reduced holding cost, the setup costs for all models have increased, displayed by a negative percentage in the table. Setup cost gain for the linear regression and Holt-Winters’ models are pretty similar, with increases of 40.6% and 39.7%. The LSTM has a lower increase at 23.3%, and the deterministic solution has the lowest with an increase of 19.9%. The setup costs have increased for all models compared to the setup costs without a pipeline reduction, meaning a reduced starting inventory implies increased setups.

All models have reduced total costs compared to Brynild’s approach, even with an increase in setup costs, as the holding costs generally are higher than the setup costs.

The deterministic solution reduced the total costs by 66.7%, up from 41.1% without the pipeline reduction. Of the stochastic solutions, the linear regression model gives the highest reduction in total costs of 32.7% on average. The Holt-Winters model follows closely, with a reduction of 29.6%. The LSTM gave the least reduction at 21.9%, despite being the model with the highest reduction compared to Brynild's approach without a pipeline cut. Using stochastic models with a pipeline cut reduces the total costs significantly, but the reduction is about half of the reduction by the deterministic model. For the linear regression and Holt-Winters models, the total cost reduction is closer to the deterministic solution with a pipeline cut than without one. However, the LSTM model was closer to the deterministic solution without a pipeline reduction than with the cut.

	<b>Holding cost reduction</b>	<b>Setup cost reduction</b>	<b>Total cost reduction</b>
<b>Brynild's approach</b>	-	-	-
<b>Deterministic solution</b>	78.4%	-19.9%	66.7%
<b>Linear regression</b>	43.0%	-40.6%	32.7%
<b>Holt-Winters</b>	38.6%	-39.7%	29.6%
<b>LSTM</b>	30.9%	-23.3%	21.9%

Table 5.10: Comparing costs and service level of deterministic and stochastic solutions to Brynild's current approach with a pipeline reduction

#### 5.5.4 Results for one of the new product launches

In order to illustrate the difference between Brynild's approach, the deterministic solution, and the results from a stochastic dynamic lot sizing model with forecasted demand, Figure 5.21 displays the production, sales, and inventory for one new product launch derived from using the three models. The first figure, 5.21a, shows Brynild's approach. The pipeline fill and wholesaler fill are the production and orders prior to the pipeline date. The difference in the two fills gave a starting inventory of around 23k F-paks. The inventory level increases right after the pipeline date, up to the point of around 56k F-paks, then slowly decreases. Following the pipeline date, five setups are performed, two of which are significantly larger than the others (the first setup is on the actual pipeline date, despite being illustrated to

---

the left of the dashed line).

The next figure, 5.21b, shows the deterministic solution. The figure is identical to Brynild's approach prior to the pipeline date, as no pipeline cut is performed. Inventory is immediately reduced due to an 8-week period without production. It is then maintained at a low level, sometimes at zero. There are seven setups following the pipeline date, two more than in Brynild's approach.

Figure 5.21c shows the results from the stochastic dynamic lot sizing model with forecasted demand using linear regression. The figure is identical to Brynild's approach prior to the pipeline date also here. However, after the pipeline date, the inventory level is significantly lower than the one in Brynild's approach, although higher than the inventory in the deterministic solution. Because of the safety stock level, the inventory varies from 10-15k F-paks during the launch period. The number of setups is also increased, with a total of 11 productions.

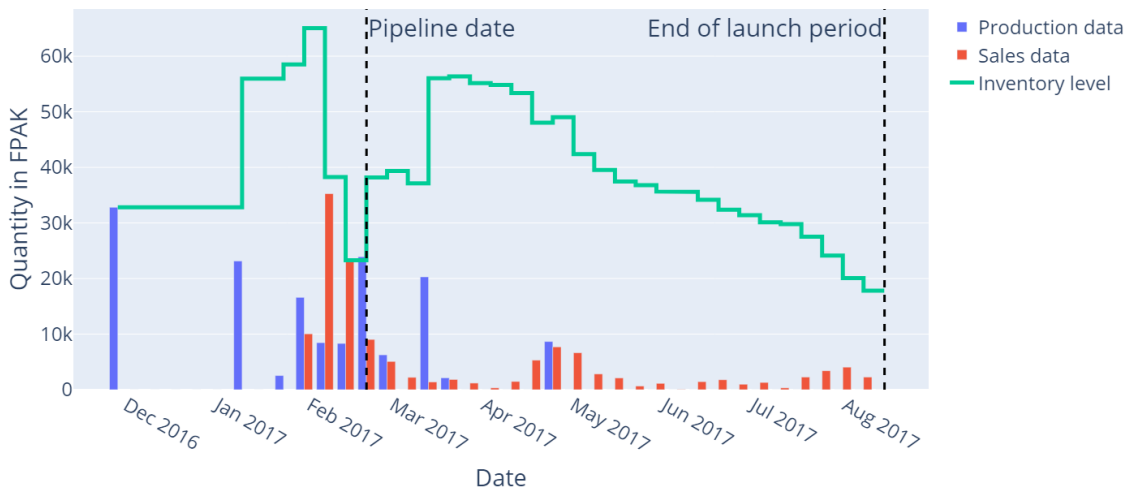

(a) Brynild's approach

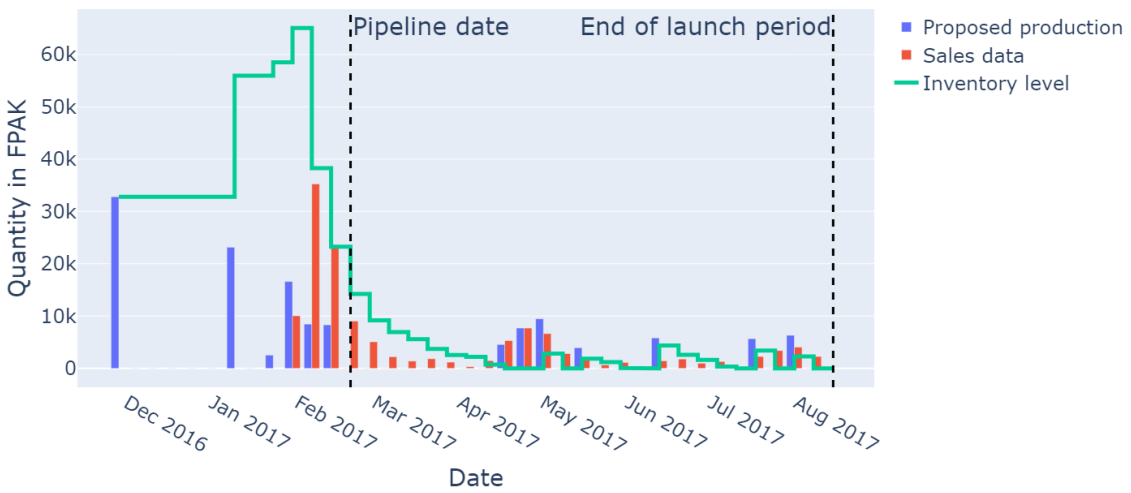

(b) Deterministic solution based on actual demand

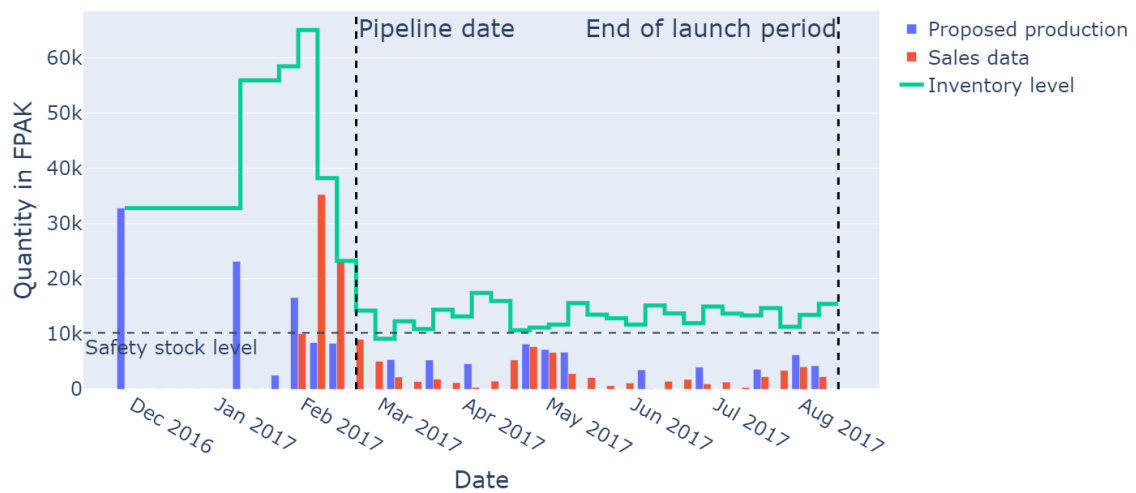

(c) Stochastic solution based on forecasted demand using linear regression

Figure 5.21: Comparison of production and inventory levels for one new product launch

---

Figure 5.22 shows similar images as in Figure 5.21, but this time with a pipeline cut for the deterministic and stochastic dynamic lot sizing solutions. The first sub-figure is the same as in figure 5.21a because there is no applied pipeline cut to Brynild's approach. In the two other graphs, figures 5.22b and 5.22c, the production prior to the launch period is lower for each setup, resulting in a starting inventory of 306 F-paks. The deterministic solution holds little inventory throughout the launch period, with 10 setups, and resembles the solution without a pipeline cut once the inventory has settled at a low point. For the stochastic solution, the safety stock level inventory is immediately produced, after which the inventory level varies similar to the solution without a pipeline cut. The number of setups remains the same at 11. These figures show that the dynamic lot sizing solutions with and without a pipeline cut are quite similar after the pipeline date and are not significantly impaired by a reduced starting inventory.

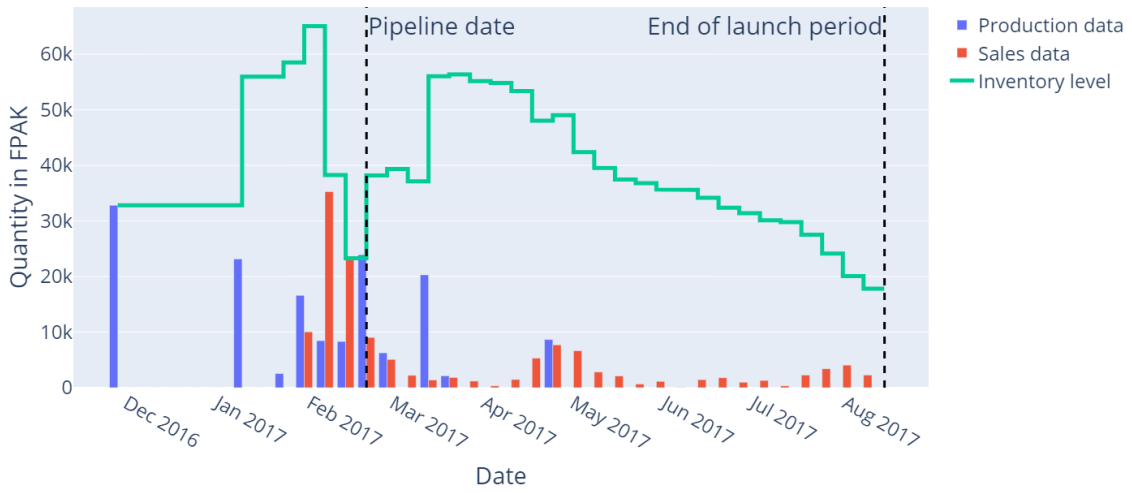

(a) Brynild's approach

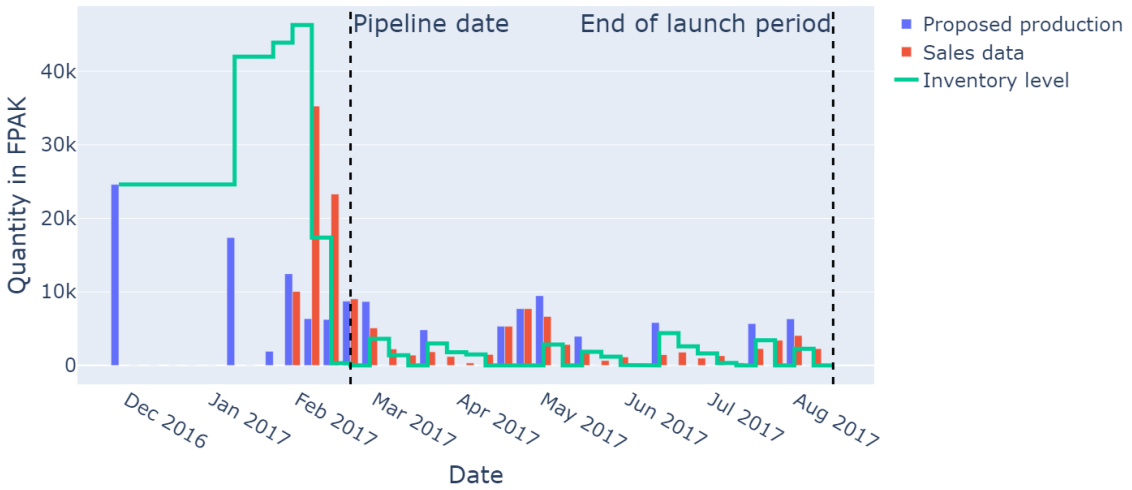

(b) Deterministic solution based on actual demand with a pipeline cut

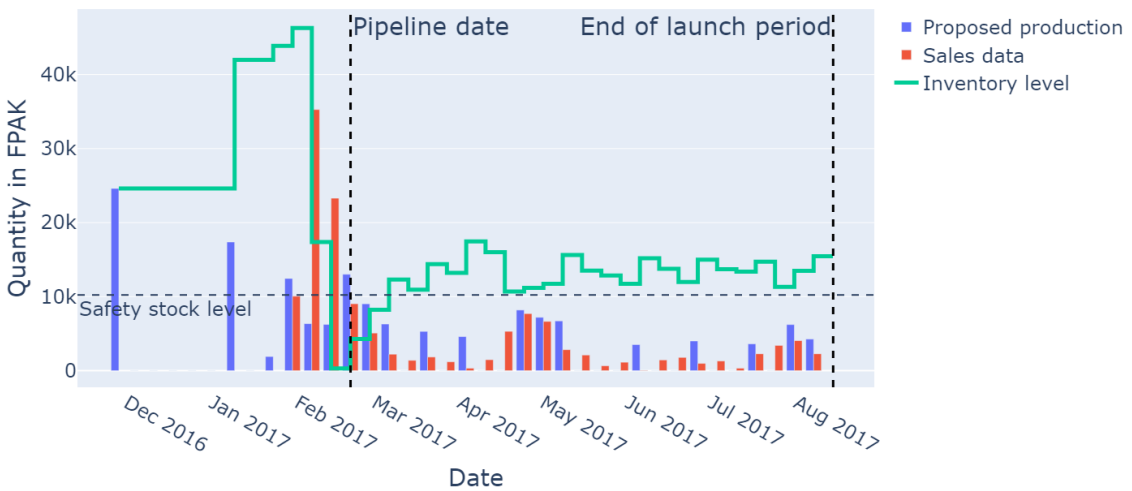

(c) Stochastic solution with forecasted demand using linear regression and a pipeline cut

Figure 5.22: Comparison of production and inventory levels for one new product launch with a pipeline cut

---

## 5.6 Discussion of findings

The goal of the case study was to investigate the effect of dynamic lot sizing with forecasts based on point of sales data on costs and service level for the case company, Brynild. The three forecasting models explained in section 5.4 were used in the data analysis. The methods were evaluated and compared in two different ways: Firstly, the forecast error of each method was measured and compared to each other. Secondly, the forecasts from each method were used as input in the dynamic lot sizing model to compare the effects on costs and service level. Additionally, to better understand the effects, Brynild's approach and a deterministic solution were used for comparison.

### 5.6.1 Forecast accuracy

The mean average percentage error (MAPE - equation 3.9) was measured for each of the four weeks into the future the methods forecasted (table 5.6). The linear regression model had an average MAPE of 60.8% during the four weeks it forecasted. Surprisingly, the model displayed the highest forecast error one week ahead before producing stable and reasonably accurate forecasts two to four weeks ahead. The high forecast error one week ahead indicates that the model is poor at predicting short-term demand spikes as they occur. As a result, it underestimates the demand during demand peaks and overestimates the demand during demand throughs. However, the model is good at estimating the overall trend, confirming our observation that the cumulative sum of the POS data resembles a linear line.

The Holt-Winters method displayed the lowest average MAPE across the four weeks, at 43.5%. As expected, Holt-Winters is good at capturing the weekly seasonality in the POS data (figure 5.12), enabling it to forecast reasonably accurately at a daily level. The forecast error was lowest one week ahead and gradually increased when forecasting further into the future, as is typical for time-series forecasts. As explained in section 5.4.2, simple exponential smoothing had to be used to forecast when only one week of POS data was available. Simple exponential smoothing does not consider seasonality and trend, negatively affecting the forecast accuracy for that week. Therefore, a different forecast method may have been more suitable until at least two complete seasonal cycles (2 weeks) of POS data were obtained.

The LSTM model had a relatively low forecast accuracy which contradicts the findings of much recent literature on LSTM networks for time-series forecasting. However, the result is not surprising as neural networks are known to require lots of

---

data to forecast accurately on unseen data (Abbasimehr et al., 2020). The training dataset consisted of 68 products, each with 26 weeks of data. In order for the network to capture underlying information and generalize to unseen data, the training dataset should ideally be many times bigger. Additionally, the test set only consisted of 9 products, which is too few to confidently argue that it represents the entire range of Brynild's new products. Regular sales after the launch period could have been included in the datasets to increase the number of data points the network was trained on. By doing so, an assumption is made that the POS data after the launch period resembles the POS data during the launch period. The idea was not tested in our study but could be a way to achieve a better forecast accuracy for the LSTM network when data is scarce. LSTM networks are highly regarded in the literature on time-series forecasting. They should not be disregarded, although the prediction accuracy in our data analysis was the worst of the three methods tested.

As explained in section 5.1.3, Brynild relies on qualitative judgment to forecast the demand for new products during their launch periods. It would have been interesting to compare the forecast accuracies of our models to Brynild's approach. However, we were unable to do so as we did not have access to historical forecasts during the launch period of the new products we examined. A requirement for implementing our suggested methods is that the forecast accuracy is greater than what is obtained by the existing approach. Brynild should investigate the matter before deciding to apply the method.

### **5.6.2 Effects on cost and service level**

The three forecasting models displayed an average MAPE ranging between 40-90%. A MAPE that high is not typically considered satisfactory in the context of short-term time series forecasting (Swanson, 2015). However, as argued by Syntetos et al. (2010), it is irresponsible to set arbitrary forecasting performance targets without considering the context of the forecast. The purpose of our forecasts was to be used in a dynamic lot sizing model to create a feasible production plan minimizing costs while maintaining a satisfactory service level. Therefore, the forecasts from all models were tested in the lot sizing model to investigate which gave the most significant cost reduction.

Our results display a significant decrease in total costs for all of our suggested forecasted solutions. The findings further show that Brynild would have been able to sustain a satisfactory service level of at least 97% while simultaneously reducing costs by implementing our suggested methods. These results corroborate the find-



---

ings of a great number of previous work that has mapped the benefits of using downstream supply chain data in demand forecasting (Olsen, 2021; Småros, 2005). With Brynild's current approach, considerable uncertainty is associated with the demand for new products. Brynild only notices how well a new product is selling once they receive re-fill orders from their wholesalers. Using our solution, Brynild can mitigate this uncertainty by using point of sales data to make frequent forecasts estimating when and at what quantity the re-fill orders will be placed.

Despite giving significant cost reductions, the stochastic solutions based on forecasted demand are not very close to the cost reduction obtained by the deterministic solution, where the demand considered is known. Refinements to the forecasting methods could increase forecast accuracy and help close the gap to the deterministic solution.

The forecasts were not accurate enough to achieve a service level above 97% in the lot sizing model without a safety stock. A probable cause is a difficulty in directly applying forecasts of point of sales data to the demand of Brynild. The forecast methods estimate future demand in the grocery stores. However, due to the ordering pattern of the retailer and wholesaler, the demand for the grocery stores one week does not always depict the order quantity of the wholesaler that week. The wholesaler may place a large order one week, although the estimated point of sales data for that week is quite low. In that case, the forecast will underestimate Brynild's actual demand, and the service level will drop as a result. Brynild estimates their safety stock to be about two to three weeks' worth of forecasted demand for a given product, although the number varies. In our analysis, the safety stock level was set as the production capacity of one setup for a given product. A safety stock at that level proved adequate to keep inventory levels slim while maintaining a satisfactory service level. Figures 5.21 and 5.22 illustrates how our proposed methods aim to produce to the forecasted demand while maintaining a necessary, but small safety stock. More accurate forecasting methods are required to reduce the safety stock further. More importantly, the method would need to precisely transform demand in the grocery stores to the demand of Brynild. This is no easy task as each of the big wholesalers Brynild sells to uses their own forecasts and ordering policy to determine when and at what quantity to place an order. Brynild could benefit from acquiring information on the ordering policy of their wholesalers. Without that information, a safety stock level is recommended to ensure a high service level.

---

## Pipeline reduction

A key reason for the observed cost reduction was the substantial cut in pipeline fill made available by our proposed method. On average, Brynild could cut the pipeline fill by 41.7% and still maintain a satisfactory service level. With a pipeline cut, total costs were lowered due to the significant reduction in holding costs, even though the setup costs increased. The increase in setup costs is expected, as the pipeline reduction did not change the number of setups prior to the launch, only the quantity per production. With lower starting inventory, more setups are required to maintain the service level.

The pipeline reduction impacts capacity usage over time. With a pipeline reduction, the need for capacity prior to launch is reduced and can instead be used in the first period after launch. By relieving the required capacity before launch, Brynild is more suited to handle changes in demand on short notice. However, it puts more pressure on Brynild to produce and deliver products quickly during the launch period.

Although a pipeline cut can significantly reduce costs, Brynild should be cautious when choosing to cut it. The pipeline fill for some products could only be cut by 10-15% while maintaining a service level of 97%. Our analysis did not introduce a penalty for not withholding the required service level. However, as explained in Section 4.1, a low service level can affect goodwill and bargaining power with the wholesaler. Therefore, although a significant pipeline fill cut is achievable and will significantly reduce holding costs, it must be carefully selected to ensure that the service level is achieved at all times. The pipeline reduction applied in our case was based on knowing the wholesaler fill. For Brynild to use a similar approach, the final listing from the wholesaler must be available in due time and must be converted into a correct volume estimation. Preferably, Brynild should agree on the quantity of the wholesaler fill long before launch to avoid having to predict it.

### 5.6.3 The dynamic lot sizing models

The dynamic lot sizing models have been developed from the fundamental dynamic lot sizing problems introduced in the theory chapter (section 3.2). As described in the theory chapter, a lot more variables and extensions can be added to the dynamic lot sizing models. The models applied in the case study are relatively simple, where a single item and a single level are used, focusing on end products. Therefore, the complexity of the problems is reduced, but the models might be too generalized compared to the actual production of Brynild, as they face both multi items and

---

levels in the real world.

The lot sizing models could be extended to include capacity variables like overtime, a method Brynild uses to increase the capacity when required. Assumptions about the capacity were made in the models based on the average production quantity per production and the average number of setups. As the model is a single item and single level model, the capacity restrictions might not reflect the total capacity of Brynild. Brynild's capacity is highly affected by the timing of the manufacturing, as multiple machines, such as the packaging machine, are used for multiple products.

The capacity restrictions can be a reason why the lot sizing models could not find a solution for all new product launches, as there is insufficient capacity to meet the demand. The reduced number of solutions found with a pipeline fill reduction supports this, as more capacity is required after the pipeline date in that case. The deterministic lot sizing model without a pipeline reduction did not find a solution for one of the new product launches, indicating that the demand for one product was impossible to produce with the given capacity. For the remaining 63 products, the capacity was sufficient to produce to the demand, resulting in a service level of 100%. The deterministic model with a pipeline reduction did not find a solution for six of the new product launches, indicating that the pipeline reduction was too big for these products.

To make the lot sizing model more realistic, it could consider time-consuming activities like production, setup, and transportation. The models assume one week lead time, meaning that the products produced in a week can be used to meet orders that same week. A lead time of one week is not necessarily feasible for all of Brynild's products, especially those containing multiple items.

The models used in the case study focus on the trade-off between holding costs and setup costs. However, the dynamic lot sizing models could have considered additional variables, such as production costs. From the case study findings, we saw that the holding costs are higher than the setup costs. As a result, the dynamic lot sizing models will try to reduce the holding cost more than the setup cost to find the best solution. The setup and holding costs used in the models were set from general assumptions, which might not reflect the actual costs equally accurately for each product. Inaccurate holding and setup costs could be a source of error in the results. Furthermore, as Brynild does not consider holding costs and setup costs, the dynamic lot sizing models could have been tested with other objective functions like maximizing service levels or minimizing setup times.

The stochastic lot sizing models were implemented with a rolling horizon approach.

---

Further investigation could be made on different planning horizons for the forecasts and production. In the stochastic models, the planning horizon was set to four weeks, and only the suggested production for the first week was executed. A four-week forecast horizon was chosen as the goal was to investigate short-term forecasting. Only the first week of the four-week production plan resulting from the dynamic lot sizing model was executed as forecasts were produced weekly. A production lead time of one week is required for our proposed solution to be feasible. Brynild should investigate different planning horizons for the products with longer lead times.

The stochastic models were implemented using a lost sales service policy. A model considering back-ordering could have been tested. Moreover, the safety stock was introduced because the stochastic lot sizing models gave insufficient service levels without it. The safety stock level was set equal to the average production capacity per setup, which is the same as the capacity for one week. For some products, this could mean a relatively high safety stock, substantially increasing the holding costs. Furthermore, variations in the forecast accuracy could impact the need for a safety stock, thereby affecting the holding costs.

Only point of sales data from NorgesGruppen was used, and the production data of Brynild was therefore scaled down based on the sales to NorgesGruppen ratio, calculated on historical order data. The ratio of sales to NorgesGruppen looks at the whole launch period at once. However, the actual ratio of sales to NorgesGruppen can vary over time, especially in periods with campaigns. As a result, the production data and other scaled variables can give wrong estimates. Wrong scaling distorts the costs derived from Brynild's current approach. The reason for the downscaling was to focus solely on demand from NorgesGruppen, but an alternative could be to scale the demand from NorgesGruppen up to reflect the total demand. This may result in a more holistic model, demonstrating how Brynild could operate if POS data were available from all wholesalers.

The down-scaled production had some implications on the results and the applicability of the methods. Our approach shows how Brynild should produce new products for one of the major customers, but Brynild also has to produce the rest of the demand from other customers and products. In order to use the proposed method, each wholesaler should be forecasted separately, preferably using forecasts based on POS data if POS data is available. Then, the total demand can be aggregated and used in the dynamic lot sizing model. Forecasting and incorporating demand from other wholesalers will increase the production volumes and holding costs. However, setup costs might not increase as much since the capacity for each setup will increase in that case. As the lot sizing models applied here are single item and single level

---

focusing on the finished product, the output of the models results in a production plan similar to the master production schedule. The output of the lot sizing model has to be considered and joined together with the master production schedule of other products to ensure that the total capacity is not exceeded. Then, the schedule must be exploded in material requirements planning to determine the need for parts and materials.

Despite simplified dynamic lot sizing models with several assumptions, they serve the purpose of investigating the effects of forecasted POS data. The deterministic and stochastic models use the same assumptions and are therefore comparable. The models are not as comparable to Brynild's approach, however, the assumptions do not make for a deviation far from the real-world situation.

---

# Chapter 6

## Discussion

This chapter discusses the study's main findings in light of the research question formalized to guide the study:

**RQ:** How can demand forecasting of point of sales data facilitate dynamic lot sizing for new product launches?

Firstly, our findings regarding demand forecasting based on POS data for new product launches are summarised and discussed. Secondly, the development and application of the dynamic lot sizing models are addressed. Finally, guidelines on implementing dynamic lot sizing based on POS forecasts for new products are provided. The guidelines are built on findings from the literature study and case study and aim to give manufacturers step-by-step instructions on how to recreate our solution adapted to the characteristics of the given producer.

### 6.1 Demand forecasting of new products

Demand forecasting of new products is particularly challenging as historical data is not available as an indicator of future demand (R.M. van Steenbergen, 2020). The forecast guides operations such as capacity planning, procurement, and inventory control, and failing to manage these operations appropriately has proven particularly costly for new product launches (Lee et al., 2014; Basallo-Triana et al., 2017; Wright and Stern, 2015). Qualitative methods such as expert opinions are the most widespread techniques applied for new product forecasting as they do not require historical data (Kahn, 2002). However, the literature suggests that qualitative methods can be time-consuming, unreliable, and difficult to generalize (Kahn, 2014), implying the need for quantitative methods for new product launches. Manufacturers

---

primarily use historical customer orders to forecast future demand (Dreyer et al., 2016). However, with no previous order history, predicting the time and quantity of new orders proves difficult. In our case study, we investigated the use of point of sales data from grocery stores in forecasts for a food manufacturer. Combining the forecasts with dynamic lot sizing displayed a significant reduction in costs compared to the case company's current approach, which relied on qualitative methods. Forecasting based on POS data could also be beneficial for other usages than dynamic lot sizing. The forecast should be made available for all departments in a manufacturing company since most departments can benefit from utilizing it for their needs, as elaborated in table 3.2. For example, the sales and marketing department can use the forecasts to effectively perform demand management, like initiating campaigns or decide on a price change. If the sales of a new product stagnate at a lower level than expected, reduced information lead time on actual demand can aid in deciding to initiate a campaign earlier. Deciding on a campaign as quickly as possible is particularly important in the food supply chain as most campaigns need to be agreed upon many weeks prior. Using downstream supply chain data when forecasting new products can also benefit manufacturers other than food manufacturers. Demand uncertainty related to new products is common for most manufacturers, and performing large pipeline fills prior to launch is a widespread method to ensure meeting the demand during a product's launch period. The forecast methods used in our case study can be applied the same way for manufacturers producing other products, as it only considers the product's sales data.

The forecasting error obtained by the forecasting models in the case study was higher than what is common in short-term time-series forecasting, raising the question of whether the selected models are the most suitable for the task. The forecast accuracy of a model is highly dependent on the characteristics of the data it forecasts. It was clear that the LSTM network applied in our case study was trained on too little data as it had a very high and random error distribution across the four weeks it forecasted. Manufacturers with access to POS data during the launch period of more products are likely to see a better performance using an LSTM network. Another selected method was the Holt-Winters' method which is regarded as one of the top statistical forecasting methods in terms of accuracy and applicability. It was selected for our case study due to its ability to capture the seasonality and trend components in the data it forecasts. Sales of sugar and confectionery products in Norway typically follow a weekly seasonal cycle with increased sales on Fridays and Saturdays and a decrease on Sundays as most stores hold close on Sundays. The method was suitable in our case but may not be as fitting for manufacturers producing products without a clear short-term seasonal pattern. If the method

---

requires months of data before being able to forecast accurately, it is not applicable for new product forecasting. The last of our three selected forecasting models was a linear regression model. It was chosen due to the linear correlation identified in the cumulative POS data. The demand profile of other new products may not resemble those of the products examined in this study. Therefore, descriptive data analysis is required to investigate if the model is suitable for another manufacturer.

Converting a forecast of POS data to a prediction of the manufacturer's demand is a particularly challenging task. In our case study, we chose to directly translate the forecasted POS demand to the anticipated demand for the case manufacturer. That means that the anticipated POS demand for one week was used as the estimated demand for the manufacturer the same week. Our chosen method resulted in significant cost savings and gave no trouble sustaining a satisfactory service level after introducing a safety stock. However, manufacturers may experience a delay between sales occurring in the retail store and when it is represented in the form of an order to them. If so, the POS forecast for one week may represent the manufacturer's demand several weeks later, which should be considered when using the forecast. (Flaarønning and Løvhaugen, 2021) analyzed the same case study company and found the delay to be around 11 days. The delay is probably different for each manufacturer as the retailer's lead times and ordering policies may differ. A possible way of surpassing the issue is to create a model to forecast manufacturer demand directly from POS data. Machine learning methods are probably best capable of doing so, as an arbitrary target function can be put to its input data. However, additional data to POS data is probably needed for the model to predict accurately in that case. In particular, information regarding the ordering policy of the retailer may help the model significantly.

## 6.2 Dynamic lot sizing

Using shared supply chain data can provide benefits such as increased forecast accuracy and response time, reducing the uncertainty in the production system (Småros, 2005). Therefore, dynamic lot sizing was applied to test the effects of forecasting based on point of sales data within production planning and control. The dynamic lot sizing models developed and tested in this thesis are relatively simple versions with several assumptions. The deterministic model with known demand was compared to the stochastic models with forecasted demand. Brynild's approach was also used as a reference point when comparing the cost reduction achieved by applying dynamic lot sizing. The results showed a significant cost reduction while the



---

service level was sustained for all forecasting methods, especially with a pipeline reduction prior to launch. However, the stochastic models were still not very close to the deterministic solution. The deterministic solution represents the effect of lot sizing, while the stochastic models have a combined effect of both forecasting and lot sizing. As a result, distinguishing the effects were difficult. Specifying the direct effect of the forecasting on point of sales could have been done if historical forecast data were available and used in the stochastic models for comparison.

Manufacturing planning and control systems are highly impacted by the presence of uncertainties, especially regarding inventory decisions and customer service (Sahin et al., 2013). The lot sizing models of this research only considered the uncertainty in demand, but literature on production planning often differentiates uncertainty from demand, process, and supply (Guillaume et al., 2017). These uncertainties involve production output, lead times, machine breakdowns, and supplier deliveries, all impacting lot sizing decisions (Koh and Saad, 2003). Considering these uncertainties makes the lot sizing decision more complex and challenging. As the focus of our study was new product launches, these uncertainties might be even more present as the manufacturers are unfamiliar with the product. Incorporating these uncertainties in the study could have affected cost reductions and service levels as reducing inventory is more challenging in the face of uncertainties.

Despite the benefits acquired from dynamic lot sizing shown in the case study, it can be challenging to implement. The majority of manufacturing companies use Enterprise Resource Planning (ERP) systems to perform Master Production Scheduling (MPS) and Material Requirements Planning (MRP) (Atadeniz and Sridharan, 2020). Most ERP systems have the functionality to consider lot sizing decisions, but only newer versions have more advanced lot sizing functionality. A decision on whether to develop a lot sizing model outside the ERP system or use the ERP system is a decision manufacturing companies need to make. For this reason, understanding how forecast errors and potentially reduced forecast errors impact the lot sizing is vital to consider. De Bodt et al. (1984) were one of the first to evaluate the effects of forecast errors on the performance of lot sizing with stochastic demand under a rolling horizon. Results from the study showed that the forecast accuracy severely impacts the effect of the lot sizing decisions. Consequently, improved forecast accuracy may not result in cost reductions if the lot sizing policy is neglected.

Dynamic lot sizing with stochastic variables like forecasted demand is commonly implemented with a rolling horizon approach, as was done in the case study (Sahin et al., 2013). The rolling horizon approach gives the advantage of incorporating the newest information on actual demand as soon as it becomes available. This provides

---

the opportunity to adjust original plans not implemented yet, based on updated demand forecasts, which is the main advantage of the rolling horizon approach (Tavaghof-Gigloo and Minner, 2021). The approach is particularly beneficial when demand uncertainty is high such as for new product launches.

However, ERP systems based on MRP are known to be prone to nervousness caused by uncertain demand and lot sizing decisions, especially when using a rolling horizon approach, as new schedules may differ significantly from previous plans (Blackburn et al., 1985). On the other hand, rarely changing the MPS can lead to increased inventory or poor service levels, hence evaluating advantages and disadvantages is necessary (Dolgui and Prodhon, 2007). During a new launch period with highly uncertain demand, actual demand might vary significantly from the forecast. This could happen for any forecast, but using point of sales data in the forecast can reduce the time to awareness of actual demand. Reacting to the actual demand can cause changes in the master production schedule leading to nervousness, but since it is a new product launch, the nervousness can be expected. In addition, as only new product launches are considered in the lot sizing models, the overall nervousness might not be affected as much if mature products are a bigger part of the production system. As a result, the production of new product launches could be focused more on a chase strategy with dynamic lot sizing during the launch period before stabilizing with a level strategy when historical demand patterns are established.

Safety stocks, safety lead times, and freezing the schedule are common approaches that can reduce the uncertainty and nervousness (Guillaume et al., 2017). These decisions should be considered alongside the lot sizing. The rolling horizon approach implemented in the case study did not incorporate freezing of the master schedule, possibly making changes to the schedule each week. Additionally, choosing the right safety stock level is critical for both costs and the nervousness from the stochastic environment (Sahin et al., 2013). However, safety stock planning and lot sizing are often solved sequentially even though safety stocks impact the lot sizing decision (Tavaghof-Gigloo and Minner, 2021; Kumar and Aouam, 2018).

The research of Kovtun et al. (2019); Wei et al. (2019); Pei and Yan (2019) showed that supply chain cooperation and data sharing could reduce the bullwhip effect. Inaccurate forecasting is a major cause of the bullwhip effect, so using accurate short-term forecasts might reduce the effect (Su and Wong, 2008). However, nervousness from a rolling horizon can contribute to the bullwhip effect (Atadeniz and Sridharan, 2020). Understanding how dynamic lot sizing is affected by nervousness and methods to reduce it is therefore essential so that the benefits of sharing supply chain data

---

on the bullwhip effect are not reduced by nervousness. Safety stocks were added in the case study, which could reduce nervousness, but this was not investigated. Nonetheless, the safety stocks are a likely reason why the different stochastic models have relatively similar cost reductions, despite having different forecast accuracy. Safety stocks could also be a reason for why the stochastic models had less reduced costs compared to the deterministic solution.

Furthermore, the study of Ho and Ireland (1998) showed that a properly chosen lot sizing method could counteract some of the nervousness in the system and neutralize the negative effect of forecast errors. These results indicate that thoroughly combining demand forecasting based on point of sales data and dynamic lot sizing can be beneficial for manufacturers during new product launches. This demonstrates that forecasting with point of sales data can facilitate dynamic lot sizing, but decisions such as safety stock levels made to decrease uncertainties heavily influence the final outcome. The focus of this study was on the effect on cost reduction and service level, and nervousness was not examined. However, this should be examined when implementing the proposed method in practice, as the proposed method may increase nervousness, making the planning more challenging to realize.

As described above, lot sizing is one of the most important and complex problems in manufacturing planning and control (Campuzano-Bolarín et al., 2020). Companies wanting to explore the advantages of dynamic lot sizing with forecasted demand based on point of sales data should be fully aware of the possible impacts it can have on their production system. Nevertheless, as uncertainties in production planning and control system are so challenging, improving forecast accuracy to reduce demand uncertainty is particularly important and should be the first thing to consider (Dolgui and Prodhon, 2007). Short-term demand forecasting using POS data considerably reduces the demand uncertainty associated with new product launches and, as a result, facilitates dynamic lot sizing.

### **6.3 Guidelines on using dynamic lot sizing based on forecasts of point of sales data for new product launches**

The following guidelines present a practitioner's guide to implementing dynamic lot sizing based on forecasts of POS data for new product launches. The guidelines were built on the findings from the literature study and case study and aim to give

---

key points for a successful implementation of our proposed method.

Before applying this guide, it is crucial that the manufacturer have a clear motivation for doing so. The process of establishing a well-functioning solution is time-consuming and resource-demanding. Many implications must be considered, as outlined in Section 6.2. Therefore, current challenges concerning new product launches should be explored to identify areas of improvement. The current production planning process should be thoroughly analyzed. Important performance measures to investigate includes inventory and service levels during the launch period of previously released products. Once areas of improvement have been identified, a decision can be made on whether dynamic lot sizing using forecasts based on POS is the right solution to solve the challenges the company is facing. If so, the following guidelines will aid in implementing the solution:

### **Step 1. Identify characteristics and key performance indicators**

Once a decision is made to implement the solution, the first step is to identify important characteristics of the manufacturer and its products that must be considered. In particular, the following characteristics must be established:

- Production lead time for the new products
- Capacity constraints on the machines
- Holding cost associated with storing inventory of the new products
- Setup cost per production setup

The characteristics will be used to configure and set constraints to the dynamic lot sizing model, as well as evaluate the suggested approach. Next, key performance indicators (KPIs) should be determined to provide a way of comparing the dynamic lot sizing solution to the current approach. Possible KPIs include setup and holding costs, service level, and stock level.

### **Step 2. Collaboration and information sharing**

The second step is to arrange for collaboration and information sharing with downstream supply chain actors. Supply chain collaboration can be challenging, as discussed in section 3.4.3. Bargaining power is typically the biggest for the more

---

prominent downstream actors, and as a result, they may need some convincing to agree to share data. Presenting the benefits they can expect to experience, such as increased product availability and store replenishment efficiency, will be crucial in convincing them to enter a collaboration agreement.

Once collaboration is established, the next step is to create a system for sharing data. Most important is gaining access to point of sales data. Additional data, such as inventory data, forecasts, and ordering policies, can also prove beneficial and should be collected if possible, although it is not vital to implement our suggested method. The data needs to be collected at a frequent interval, ideally weekly, and must be complete and up to date. Align the data gathering frequency with the production characteristics defined in step 1 to ensure the data is available in time to make a forecast and produce to the anticipated demand respecting lead times and capacity constraints.

The actual data exchange should be automated to speed up the information exchange and reduce the risks of data entry errors. To ensure system compatibility and that all parties interpret the data alike, the data must be standardized. This is particularly important in the case of collecting data from multiple customers. Data should be collected for all customers, and in the same format, in order to facilitate forecasting the aggregated demand as accurately as possible.

### **Step 3. Determine forecast and production horizon**

Once key production characteristics are identified, and collaboration is agreed upon, the manufacturer must determine the length of the forecast and production horizon. In particular, the following factors must be determined:

- How frequently to forecast
- How many weeks ahead the forecast should cover
- What parts of the production schedule resulting from the dynamic lot sizing model to use in the final production plan

The frequency of forecasts is determined partly by how frequently the manufacturer receives point of sales data from its customers. A weekly forecast frequency is recommended. The number of weeks the forecast should cover depends on the production lead time of the products to produce. If the lead time of a product is one month, forecasting four weeks ahead will not be sufficient, as the production

---

plan can not be altered in time to meet the anticipated demand. The forecast length coincides with what parts of the suggested production plan to keep. Lead times related to procurement, inventory, and transport must be considered.

#### **Step 4. Determine a suitable short-term forecasting method on POS data**

The fourth step is testing and evaluating different time-series forecasting methods on POS data. The models developed during the case study of this study (Section 5.4) can be used as a starting point. However, there is no guarantee that the models will perform equally well on different data. Therefore, multiple models should be tested and compared by measuring the MAPE (Equation 3.9) of the forecasts they produce on historical data. We also recommend trying multiple models in the dynamic lot sizing model to investigate their effects on costs and service level.

#### **Step 5. Develop a dynamic lot sizing model**

The next step is to develop a dynamic lot sizing model similar to the one described in Section 5.4.4. To emulate our proposed method, the objective of the model should be to minimize the sum of setup and holding costs. The characteristics determined in Step 1 must be used to establish the model's constraints. All capacity constraints must be accurately depicted in the model to produce a feasible production plan. The lot sizing model should ideally be multi-item and take into account all of the producer's end items. As a result, the model can be automated to a greater extent without the need for manual adjustments to account for regular demand of mature products.

#### **Step 6. Test and evaluate the solution on historical data**

Before implementing the solution on new product launches, it should be tested on the data of previously launched products. The forecasting accuracy of the selected model should be measured to ensure it can predict accurately. Additionally, the production schedule resulting from the dynamic lot sizing model should be manually examined by production planners to ensure they produce feasible production plans not causing significant nervousness. Coherent policies, like safety stocks, should be evaluated simultaneously. The goal is to create a system that can run without manual interference, hence adjustments to the forecasting and lot sizing model should be made until it can be run on its own. The key performance indicators determined

---

in step 1 should be measured and compared to the current solution. The proposed solution should also be compared against a deterministic solution, as was done in the case study of this master thesis (table 5.8 and 5.10). A requirement for implementing the solution is that it performs better than the current approach. The goal is for it to be as close to the deterministic solution as possible.

### **Step 7. Gradually implement dynamic lot sizing with forecasted demand**

Once the solution is evaluated on historical data and gives satisfactory results, it can gradually be implemented in the actual demand forecasting and production planning of new products. Before applying the solution to all new products, it should be tested on a few products. It is vital to measure all key performance indicators determined in step 1 as accurately as possible. Also, any implications that arise during the test period must be formalized and discussed. The process of developing this method is iterative, and challenges must continuously be addressed to optimize the method for future use.

During our case study, we measured the models' performance based on the cost reduction it gave compared to the current approach, as well as the service level obtained by implementing the method. The service level is particularly important to measure as it is one of the factors in danger of being reduced by implementing the proposed solution. A poor service level affects goodwill and bargaining power to the customers, as discussed in section 4.1. To ensure a satisfactory service level while the methods are still being tested for real use, we recommend a gradual decrease in the pipeline fill. Additionally, the safety stock can initially be set to a relatively high level, further assuring product availability. The goal will be to gradually reduce the pipeline fill and safety stock when the method is refined and tested to the point where the manufacturer is confident enough to rely on it without additional safety measures.

## **6.4 Limitations and further work**

A weakness of the case study is that it only considered one case company. Without considering more companies, we can not confidently argue for the reliability and replicability of the proposed methods. However, the literature studies ascertained the findings from the case study, giving credibility to the solution. Nevertheless, further research should include more companies to investigate the generalisability of the methods in different industries and for different manufacturers.

---

Another limitation of the study is the lack of data as well as partially missing data. The data cleaning in the case study showed that 92 of 156 had to be removed, resulting in only 64 new product launches to investigate. Further research should preferably include more data. In addition, further work should investigate including more supply chain data other than POS data when forecasting new product launches. The additional data may include inventory levels, reorder points at stores, and orders from retail stores to wholesalers.

The dynamic lot sizing models used in the case study were based on many assumptions. The assumptions may not reflect the actual situation of the case company for all products investigated. Effects on costs and service level could differ with other assumptions. More complex lot sizing models, including the option for multi level and multi item production can be considered to make the models more realistic. Further research should investigate how point of sales data can facilitate dynamic lot sizing for new products using richer lot sizing models.



---

# Chapter 7

## Conclusion

Recent literature has mapped potential benefits of using downstream supply chain data in demand forecasting and production planning for manufacturers, including increased response time and significant cost reductions. Research is, however, scarce on the practical application of the data. The purpose of this study was to bridge that existing research gap and answer the following research question:

*”How can demand forecasting based on point of sales data facilitate dynamic lot sizing of new product launches?”.*

Demand uncertainty is particularly high for new product launches, and as a result, manufacturers commonly perform large pipeline fills to ensure product availability during the launch period. In our case study, we showed that using point of sales data could alleviate the need for a large pipeline fill, significantly reducing the holding cost caused by increased demand uncertainty during the early phase of a product’s life cycle. Our proposed method consisted of using POS data from the retailer to forecast the demand of the manufacturer. The forecasts were then used as input to a dynamic lot sizing model whose objective was to minimize setup and holding costs during the launch period of the new product. Significant cost reductions averaging at around 30% were discovered, indicating clear benefits made available through the use of dynamic lot sizing with forecasts based on POS data.

Three objectives were formalized to guide the research. The approach used to carry out the objectives, as well as the contributions derived from them, are outlined below:

*Objective 1: Identify forecasting models suited for forecasting point of sales data of new product launches*

---

The objective was achieved by conducting a literature study examining the state-of-the-art and most commonly used time-series forecasting methods. All forecasting methods were evaluated based on the forecast accuracies they displayed on the POS data, as well as the feasibility and effects of using them in a dynamic lot sizing model. The models identified were a linear regression model, the Holt-Winters' method, and an LSTM network. All models displayed a reasonable forecast accuracy and, more importantly, gave cost reductions for the case company. In that sense, the objective can be marked as complete. However, as discussed in Section 6.1, the most suitable forecast method depends on the characteristics of the data it forecasts. A manufacturer looking to apply our proposed solution should consider the specifics of their data before selecting a method.

*Objective 2: Conduct a case study to investigate the effect of dynamic lot sizing with forecasts based on point of sales data on cost reduction and service level for new product launches*

The second objective was achieved through practical application of our proposed methods on the supply chain data of the Norwegian confectionery manufacturer Brynild. In the case study, the service level and costs derived from our proposed methods were compared to that of Brynild's current approach. All proposed methods gave a significant cost reduction compared to Brynild's approach while maintaining a required service level of at least 97%. The findings shed new light on how manufacturers can use POS data and the cost benefits it can bring.

*Objective 3: Create guidelines explaining how food manufacturers can use dynamic lot sizing based on forecasts of point of sales data for new product launches*

The final objective was achieved by combining the theoretical knowledge acquired in the literature study with the practical knowledge obtained in the case study. A step-by-step guide to implementing our proposed method is outlined in Section 6.3. The guidelines are not exclusive to food manufacturers, as the proposed methods can be equally useful for manufacturers in other industries.

To conclude, this master's thesis investigated the use of point of sales data in dynamic lot sizing of new product launches. From the knowledge obtained through a case study and multiple literature studies, we can confidently assert that dynamic lot sizing using forecasted demand based on POS data can be beneficial to implement for new product launches. It has the ability to reduce demand uncertainty associated with the release of new products and provide significant cost reductions.

---

# Reference list

Abadi, M., Agarwal, A., Barham, P., Brevdo, E., Chen, Z., Citro, C., Corrado, G. S., Davis, A., Dean, J., Devin, M., Ghemawat, S., Goodfellow, I., Harp, A., Irving, G., Isard, M., Jia, Y., Jozefowicz, R., Kaiser, L., Kudlur, M., Levenberg, J., Mané, D., Monga, R., Moore, S., Murray, D., Olah, C., Schuster, M., Shlens, J., Steiner, B., Sutskever, I., Talwar, K., Tucker, P., Vanhoucke, V., Vasudevan, V., Viégas, F., Vinyals, O., Warden, P., Wattenberg, M., Wicke, M., Yu, Y. and Zheng, X. (2015), ‘TensorFlow: Large-scale machine learning on heterogeneous systems’. Software available from tensorflow.org.

**URL:** <https://www.tensorflow.org/>

Abbasimehr, H., Shabani, M. and Yousefi, M. (2020), ‘An optimized model using lstm network for demand forecasting’, *Computers & industrial engineering* **143**, 106435.

Abiodun, O. I., Jantan, A., Omolara, A. E., Dada, K. V., Mohamed, N. A. and Arshad, H. (2018), ‘State-of-the-art in artificial neural network applications: A survey’, *Heliyon* **4**(11), e00938.

Abraham, B. and Ledolter, J. (2009), *Statistical methods for forecasting*, Vol. 234, John Wiley & Sons.

Absi, N. and Kedad-Sidhoum, S. (2008), ‘The multi-item capacitated lot-sizing problem with setup times and shortage costs’, *European Journal of Operational Research* **185**(3), 1351–1374.

**URL:** <https://www.sciencedirect.com/science/article/pii/S0377221706006540>

Akartunalı, K. and Dauzère-Pérès, S. (2021), ‘Dynamic lot sizing with stochastic demand timing’.

**URL:** <https://www.sciencedirect.com/science/article/pii/S037722172101081X>

Atadeniz, S. N. and Sridharan, S. V. (2020), ‘Effectiveness of nervousness reduction policies when capacity is constrained’, *International Journal of Production Re-*

---

*search* **58**(13), 4121–4137.

**URL:** <https://doi.org/10.1080/00207543.2019.1643513>

- Baardman, L., Levin, I., Perakis, G. and Singhvi, D. (2017), ‘Leveraging comparables for new product sales forecasting’, *Available at SSRN 3086237*.
- Babu, K. K. V. (2018), New product forecasting of appliance and consumables: bass model, PhD thesis, Massachusetts Institute of Technology.
- Banerjee, A. and Banerjee, B. (2000), ‘Effective retail promotion management: use of point of sales information resources’, *Vikalpa* **25**(4), 51–60.
- Basallo-Triana, M. J., Rodríguez-Sarasty, J. A. and Benitez-Restrepo, H. D. (2017), ‘Analogue-based demand forecasting of short life-cycle products: a regression approach and a comprehensive assessment’, *International Journal of Production Research* **55**(8), 2336–2350.
- Bass, F. M. (1969), ‘A new product growth for model consumer durables’, *Management science* **15**(5), 215–227.
- Bhattacharya, R. and Bandyopadhyay, S. (2011), ‘A review of the causes of bullwhip effect in a supply chain’, *The International Journal of Advanced Manufacturing Technology* **54**(9), 1245–1261.
- Blackburn, J. D., Kropp, D. H. and Millen, R. A. (1985), ‘Mrp system nervousness: Causes and cures’, *Engineering Costs and Production Economics* **9**(1), 141–146. Special Issue of Engineering Costs and Production Economics Proceedings of the Third International Working Seminar on Production Economics.  
**URL:** <https://www.sciencedirect.com/science/article/pii/0167188X85900217>
- Bonney, M. (2000), ‘Reflections on production planning and control (ppc)’, *Gestao Producao* **7**.
- Bourlakis, M. A. and Weightman, P. W. (2008), *Food supply chain management*, John Wiley & Sons.
- Brahimi, N. (2004), ‘Production planning: Models and algorithms for lot sizing problems’.
- Brahimi, N., Absi, N., Dauzère-Pérès, S. and Nordli, A. (2017), ‘Single-item dynamic lot-sizing problems: An updated survey’, *European Journal of Operational Research* **263**(3), 838–863.  
**URL:** <https://www.sciencedirect.com/science/article/pii/S0377221717304368>

- 
- Brahimi, N., Dauzere-Peres, S., Najid, N. M. and Nordli, A. (2006), ‘Single item lot sizing problems’, *European Journal of Operational Research* **168**(1), 1–16.  
**URL:** <https://www.sciencedirect.com/science/article/pii/S0377221704003923>
- Bushuev, M. A., Guiffrida, A., Jaber, M. Y. and Khan, M. (2015), ‘A review of inventory lot sizing review papers’, **38**(3), 283–298.  
**URL:** <https://doi.org/10.1108/MRR-09-2013-0204>
- Cachon, G. P. and Fisher, M. (2000), ‘Supply chain inventory management and the value of shared information’, *Management science* **46**(8), 1032–1048.
- Campuzano-Bolarín, F., Mula, J., Díaz-Madroñero, M. and Álvaro Ginés Legaz-Aparicio (2020), ‘A rolling horizon simulation approach for managing demand with lead time variability’, *International Journal of Production Research* **58**(12), 3800–3820.  
**URL:** <https://doi.org/10.1080/00207543.2019.1634849>
- Chapman, S. N. (2006), *Fundamentals of Production Planning and Control*, Pearson Education.
- Charles, M., Dauzère-Pérès, S., Kedad-Sidhoum, S. and Mazhoud, I. (2021), ‘Motivations and analysis of the capacitated lot-sizing problem with setup times and minimum and maximum ending inventories’, *European Journal of Operational Research* .  
**URL:** <https://www.sciencedirect.com/science/article/pii/S0377221721010444>
- Chen, L. and Lee, H. L. (2009), ‘Information sharing and order variability control under a generalized demand model’, *Management science* **55**(5), 781–797.
- Chen, Z. and Yang, Y. (2004), ‘Assessing forecast accuracy measures’, *Preprint Series* **2010**, 2004–10.
- Chiung Song, Bryan L. Boulier, H. O. S. (2007), ‘The comparative accuracy of judgmental and model forecasts of american football games’, *International Journal of Forecasting* **23**.
- Choi, T.-M., Wallace, S. W. and Wang, Y. (2018), ‘Big data analytics in operations management’, *Production and Operations Management* **27**(10), 1868–1883.
- Crawford, M. and Benedetto, A. D. (2008), *New products management*, Tata McGraw-Hill Education.
- Croom, S. (2008), *Researching Operations Management*, Taylor and Francis, chapter 3.

- 
- Cui, R., Allon, G., Bassamboo, A. and Van Mieghem, J. A. (2015), ‘Information sharing in supply chains: An empirical and theoretical valuation’, *Management Science* **61**(11), 2803–2824.
- de Almeida, W. M. and da Veiga, C. P. (2022), ‘Does demand forecasting matter to retailing?’, *Journal of Marketing Analytics* pp. 1–14.
- De Bodt, M. A., Gelders, L. F. and Van Wassenhove, L. N. (1984), ‘Lot sizing under dynamic demand conditions: A review’, *Engineering Costs and Production Economics* **8**(3), 165–187.  
**URL:** <https://www.sciencedirect.com/science/article/pii/0167188X84900351>
- Dharmawardane, C., Sillanpää, V. and Holmström, J. (2021), ‘High-frequency forecasting for grocery point-of-sales: intervention in practice and theoretical implications for operational design’, *Operations Management Research* **14**(1), 38–60.
- Dilworth, J. B. (1996), *Operations management*, McGraw-Hill Company.
- DLF (n.d.), <https://www.dlf.no/tradesolution/>. Accessed: 2022-04-02.
- Dolgui, A. and Prodhon, C. (2007), ‘Supply planning under uncertainties in mrp environments: A state of the art’, *Annual Reviews in Control* **31**(2), 269–279.  
**URL:** <https://www.sciencedirect.com/science/article/pii/S1367578807000429>
- Draganska, M. and Klapper, D. (2007), ‘Retail environment and manufacturer competitive intensity’, **83**(2), 183–198.  
**URL:** <https://www.sciencedirect.com/science/article/pii/S002243590700019X>
- Dreyer, H. C., Kiil, K., Dukovska-Popovska, I. and Kaipia, R. (2018), ‘Proposals for enhancing tactical planning in grocery retailing with s&op’, *International Journal of Physical Distribution & Logistics Management*.
- Dreyer, H. C., Strandhagen, J. O., Hvolby, H.-H., Romsdal, A. and Alfnes, E. (2016), ‘Supply chain strategies for speciality foods: a norwegian case study’, *Production Planning & Control* **27**(11), 878–893.
- Dreyer, H. C., Strandhagen, J. O., Thomassen, M. K., Romsdal, A. and Gran, E. (2014), ‘Supply chain control principles in local food production: A norwegian case study’, *International Journal on Food System Dynamics* **5**(1012-2016-81247), 53–68.
- Dreyer, H. C., Swahn, N., Kiil, K., Strandhagen, J. O. and Romsdal, A. (2015), The responsiveness of food retail supply chains: a norwegian case study, in ‘IFIP International Conference on Advances in Production Management Systems’, Springer, pp. 152–160.

- 
- Dulsrud, A. and Alfnes, F. (2015), ‘Dagligvareportalen og kvalitet’, *STATENS INSTITUTT FOR FORBRUKSFORSKNING*.
- Dulsrud, A. and Alfnes, F. (2016), ‘Vareutvalg av mat og drikke i norske dagligvarebutikker’.
- Erland Skogli, Ole Magnus Stokke, S. V. V. K. M. (2020), ‘Grossist- og distribusjonvirksomhet i norsk dagligvare: analyse av dagens organisering og vurdering av innspill knyttet til regulering’, **27**.  
**URL:** <https://www.menon.no/wp-content/uploads/2020-27-Grossist-og-distribusjonsvirksomhet-i-norsk-dagligvare.pdf>
- Federgruen, A. and Tzur, M. (1994), ‘Minimal forecast horizons and a new planning procedure for the general dynamic lot sizing model: Nervousness revisited’, **42**(3), 456–468. Publisher: INFORMS.  
**URL:** <https://pubsonline.informs.org/doi/abs/10.1287/opre.42.3.456>
- Fildes, R., Ma, S. and Kolassa, S. (2019), ‘Retail forecasting: Research and practice’, *International Journal of Forecasting*.
- Flaarønning, H. T. and Løvhaugen, E. (2021), ‘Investigating the use of point of sales data in demand planning of new product launches for food producers’.
- Friston, K. J., Harrison, L. and Penny, W. (2003), ‘Dynamic causal modelling’, *Neuroimage* **19**(4), 1273–1302.
- García, S., Luengo, J. and Herrera, F. (2015), *Data preprocessing in data mining*, Vol. 72, Springer.
- Gelper, S., Wilms, I. and Croux, C. (2016), ‘Identifying demand effects in a large network of product categories’, *Journal of Retailing* **92**(1), 25–39.
- Georgiadis, G. P., Mariño Pampín, B., Adrián Cabo, D. and Georgiadis, M. C. (2020), ‘Optimal production scheduling of food process industries’, *Computers Chemical Engineering* **134**, 106682.  
**URL:** <https://www.sciencedirect.com/science/article/pii/S0098135419309603>
- Glock, C. H., Grosse, E. H. and Ries, J. M. (2014), ‘The lot sizing problem: A tertiary study’, *International Journal of Production Economics* **155**, 39–51. Celebrating a century of the economic order quantity model.  
**URL:** <https://www.sciencedirect.com/science/article/pii/S0925527313005689>
- Gomila, R. (2021), ‘Logistic or linear? estimating causal effects of experimental treatments on binary outcomes using regression analysis.’, *Journal of Experimental Psychology: General* **150**(4), 700.
-

- 
- Goodwin, P., Dyussekeneva, K. and Meeran, S. (2013), ‘The use of analogies in forecasting the annual sales of new electronics products’, *IMA Journal of Management Mathematics* **24**(4), 407–422.
- Google Colab (n.d.), [https://colab.research.google.com/?utm\\_source=scs-index](https://colab.research.google.com/?utm_source=scs-index). Accessed: 2022-04-22.
- Grimson, J. A. and Pyke, D. F. (2007), ‘Sales and operations planning: an exploratory study and framework’, *The International journal of logistics management*. **18**(3), 322–346.
- Guillaume, R., Thierry, C. and Zieliński, P. (2017), ‘Robust material requirement planning with cumulative demand under uncertainty’, *International Journal of Production Research* **55**(22), 6824–6845.  
**URL:** <https://doi.org/10.1080/00207543.2017.1353157>
- Gunasekaran, A. et al. (2004), ‘Supply chain management: Theory and applications’, *European Journal of Operational Research* **159**(2), 265–268.
- Gurobi Optimization, LLC (2022), ‘Gurobi Optimizer Reference Manual’. Accessed: 2022-04-22.  
**URL:** <https://www.gurobi.com>
- Haase, K. (1994), *Lotsizing and Scheduling for Production Planning*, Springer Science & Business Media.
- Harris, F. W. (1990), ‘How many parts to make at once’.
- Hartzel, K. S. and Wood, C. A. (2017), ‘Factors that affect the improvement of demand forecast accuracy through point-of-sale reporting’, *European Journal of Operational Research* **260**(1), 171–182.
- Hipp, R. D. (2020), ‘SQLite’.  
**URL:** <https://www.sqlite.org/index.html>
- Ho, C.-J. and Ireland, T. (1998), ‘Correlating mrp system nervousness with forecast errors’, *International Journal of Production Research* **36**(8), 2285–2299.  
**URL:** <https://doi.org/10.1080/002075498192904>
- Hochreiter, S. (1998), ‘The vanishing gradient problem during learning recurrent neural nets and problem solutions’, *International Journal of Uncertainty, Fuzziness and Knowledge-Based Systems* **6**(02), 107–116.



- 
- Holmström, J., Holweg, M., Lawson, B., Pil, F. K. and Wagner, S. M. (2019), ‘The digitalization of operations and supply chain management: Theoretical and methodological implications’.
- Holt, C. C. (2004), ‘Forecasting seasonals and trends by exponentially weighted moving averages’, *International journal of forecasting* **20**(1), 5–10.
- Horvat, A., Granato, G., Fogliano, V. and Luning, P. A. (2019), ‘Understanding consumer data use in new product development and the product life cycle in european food firms—an empirical study’, *Food Quality and Preference* **76**, 20–32.
- Hua, Z. and Li, S. (2008), ‘Impacts of demand uncertainty on retailer’s dominance and manufacturer-retailer supply chain cooperation’, *Omega* **36**(5), 697–714.
- Huchzermeier, A. and Iyer, A. V. (2006), Supply chain management in a promotional environment, in ‘Retailing in the 21st Century’, Springer, pp. 325–344.
- Hvolby, H.-H. and Steger-Jensen, K. (2015), ‘Managing cannibalization of perishable food products in the retail sector’, *Procedia Computer Science* **64**, 1051–1056.
- Hyndman, R. J. and Athanasopoulos, G. (2018), *Forecasting: principles and practice*, OTexts.
- Inc., P. T. (2015), ‘Collaborative data science’.  
**URL:** <https://plot.ly>
- Jacobs, F., Berry, W. L., Whybark, D. C. and Vollmann, T. E. (2011), *Manufacturing planning and control for supply chain management*, McGraw Hill Professiona.
- Jans, R. and Degraeve, Z. (2007), ‘Meta-heuristics for dynamic lot sizing: A review and comparison of solution approaches’, *European Journal of Operational Research* **177**(3), 1855–1875.  
**URL:** <https://www.sciencedirect.com/science/article/pii/S0377221705008416>
- Jans, R. and Degraeve, Z. (2008), ‘Modeling industrial lot sizing problems: a review’, *International Journal of Production Research* **46**(6), 1619–1643.  
**URL:** <https://doi.org/10.1080/00207540600902262>
- Jorgenson, D. W., Stiroh, K. J., Gordon, R. J. and Sichel, D. E. (2000), ‘Raising the speed limit: Us economic growth in the information age’, *Brookings papers on economic activity* **2000**(1), 125–235.
- Kahn, K. B. (2002), ‘An exploratory investigation of new product forecasting practices’, *Journal of Product Innovation Management: AN INTERNATIONAL*
-

- Kahn, K. B. (2005), *The PDMA handbook of new product development*, Hoboken, NJ: Wiley, c2005.
- Kahn, K. B. (2014), *New product forecasting: an applied approach*, Routledge.
- Karimi, B., Fatemi Ghomi, S. and Wilson, J. (2003), ‘The capacitated lot sizing problem: a review of models and algorithms’, *Omega* **31**(5), 365–378.  
**URL:** <https://www.sciencedirect.com/science/article/pii/S0305048303000598>
- Karlsson, C. (2010), *Researching Operations Management*, Routledge.
- Ketzenberg, M. and Ferguson, M. E. (2008), ‘Managing slow-moving perishables in the grocery industry’, *Production and Operations Management* **17**(5), 513–521.
- Kim, S. C. and Shin, K. S. (2019), ‘Negotiation model for optimal replenishment planning considering defects under the vmi and jit environment’, *The Asian Journal of Shipping and Logistics* **35**(3), 147–153.
- Koh, S. and Saad, S. (2003), ‘Mrp-controlled manufacturing environment disturbed by uncertainty’, *Robotics and Computer-Integrated Manufacturing* **19**(1), 157–171. 12th International Conference on Flexible Automation and Intelligent Manufacturing.  
**URL:** <https://www.sciencedirect.com/science/article/pii/S073658450200073X>
- Kothari, C. (2004), *Research Methodology Methods and Techniques*, New Age International.
- Kourentzes, N., Trapero, J. R. and Barrow, D. K. (2020), ‘Optimising forecasting models for inventory planning’, *International Journal of Production Economics* **225**, 107597.  
**URL:** <https://www.sciencedirect.com/science/article/pii/S0925527319304323>
- Kovtun, V., Giloni, A. and Hurvich, C. (2019), ‘The value of sharing disaggregated information in supply chains’, *European Journal of Operational Research* **277**(2), 469–478.
- Kuhn, M. and Johnson, K. (2016), ‘Applied predictive modeling. corrected 5th printing, vol. 600’.

- 
- Kumar, K. and Aouam, T. (2018), ‘Integrated lot sizing and safety stock placement in a network of production facilities’, *International Journal of Production Economics* **195**, 74–95.  
**URL:** <https://www.sciencedirect.com/science/article/pii/S0925527317303092>
- Lapide, L. (2002), ‘New developments in business forecasting’, *The Journal of Business Forecasting* **21**(1), 12.
- Lawrence, M., O’Connor, M. and Edmundson, B. (2000), ‘A field study of sales forecasting accuracy and processes’, *European Journal of Operational Research* **122**(1), 151–160.  
**URL:** <https://www.sciencedirect.com/science/article/pii/S0377221799000855>
- LeCun, Y., Bengio, Y. and Hinton, G. (2015), ‘Deep learning’, *nature* **521**(7553), 436–444.
- Lee, H., Kim, S. G., Park, H.-w. and Kang, P. (2014), ‘Pre-launch new product demand forecasting using the bass model: A statistical and machine learning-based approach’, *Technological Forecasting and Social Change* **86**, 49–64.
- Lee, H. L., Padmanabhan, V. and Whang, S. (1997), ‘The bullwhip effect in supply chains’, *Sloan management review* **38**, 93–102.
- Lee, H. L., So, K. C. and Tang, C. S. (2000), ‘The value of information sharing in a two-level supply chain’, *Management science* **46**(5), 626–643.
- Lee, Y. and Lee, K. (2021), ‘New integer optimization models and an approximate dynamic programming algorithm for the lot-sizing and scheduling problem with sequence-dependent setups’, *European Journal of Operational Research* .  
**URL:** <https://www.sciencedirect.com/science/article/pii/S0377221721010882>
- Lewis, C. (2012), *Demand forecasting and inventory control*, Routledge.
- Li, H. and Meissner, J. (2011), ‘Capacitated dynamic lot sizing with capacity acquisition’, *International Journal of Production Research* **49**(16), 4945–4963.  
**URL:** <https://doi.org/10.1080/00207543.2010.518991>
- Lotfi, Z., Mukhtar, M., Sahran, S. and Zadeh, A. T. (2013), ‘Information sharing in supply chain management’, *Procedia Technology* **11**, 298–304.
- Love, S. F. (1973), ‘Bounded production and inventory models with piecewise concave costs’, *Management Science* **20**(3), 313–318.  
**URL:** <https://doi.org/10.1287/mnsc.20.3.313>
-

- 
- Machuca, M. M., Sainz, M. and Costa, C. M. (2014), ‘A review of forecasting models for new products’, *Intangible capital* **10**(1), 1–25.
- Makridakis, S., Spiliotis, E. and Assimakopoulos, V. (2018a), ‘The m4 competition: Results, findings, conclusion and way forward’, *International Journal of Forecasting* **34**(4), 802–808.
- Makridakis, S., Spiliotis, E. and Assimakopoulos, V. (2018b), ‘Statistical and machine learning forecasting methods: Concerns and ways forward’, *PloS one* **13**(3), e0194889.
- Mark Davis, Nicholas Aquilano, R. C. (2003), ‘Fundamentals of operations management’, *McGraw-Hill Irwin* **4**.
- Mason-Jones, R. and Towill, D. R. (1997), ‘Information enrichment: designing the supply chain for competitive advantage’, *Supply Chain Management: An International Journal* .
- Mateus Meneghini, Michel Anzanello, A. K. G. L. T. (2018), ‘Quantitative demand forecasting adjustment based on qualitative factors: case study at a fast food restaurant’.
- Meredith, J. (1998), ‘Building operations management theory through case and field research’, **16**(4), 441–454. Reprint: <https://onlinelibrary.wiley.com/doi/pdf/10.1016/S0272-6963%2898%2900023-0>.  
**URL:** <https://onlinelibrary.wiley.com/doi/abs/10.1016/S0272-6963%2898%2900023-0>
- Mikolov, T., Karafiát, M., Burget, L., Cernocký, J. and Khudanpur, S. (2010), Recurrent neural network based language model., in ‘Interspeech’, Vol. 2, Makuhari, pp. 1045–1048.
- Moen, K., Rekdal, K. and Aronsen, K. (2018), ‘Handelsrapporten 2017/2018’, *VIRKE* .
- Mohtadi, H. and Kinsey, J. D. (2005), ‘Information exchange and strategic behavior in supply chains: Application to the food sector’, *American Journal of Agricultural Economics* **87**(3), 582–599.
- Moon, M. A. (2018), *Demand and supply integration: The key to world-class demand forecasting*, Walter de Gruyter GmbH & Co KG.
- Mou, S., Robb, D. J. and DeHoratius, N. (2018), ‘Retail store operations: Literature review and research directions’, *European Journal of Operational Research* **265**(2), 399–422.

- 
- Nahmias, S. and Cheng, Y. (2009), *Production and operations analysis*, Vol. 6, McGraw-hill New York.
- Nakayama, M. (2000), 'E-commerce and firm bargaining power shift in grocery marketing channels: A case of wholesalers' structured document exchanges', *Journal of Information Technology* **15**(3), 195–210.
- Narayanan, A. and Robinson, P. (2010), 'Evaluation of joint replenishment lot-sizing procedures in rolling horizon planning systems', *International Journal of Production Economics* **127**(1), 85–94.  
**URL:** <https://www.sciencedirect.com/science/article/pii/S0925527310001714>
- Nielsen (2020), 'Nielsen kvartalsrapport dvh q1 2020 markedsutvikling kvartalsvis offentliggjøring', *The Nielsen Company* .
- NielsenIQ (2021), 'Nielseniq – pressemelding - dagligvarerapporten 2021'.  
**URL:** <https://www.dlf.no/wp-content/uploads/2021/02/NielsenIQ-pressemelding-Dagligvarerapporten-2021.pdf>
- NOU (2011), 'Mat, makt og avmakt – om styrkeforholdene i verdikjeden for mat', *Norges offentlige utredninger* .
- Olah, C. (2015), 'Understanding lstm networks'.  
**URL:** <https://colah.github.io/posts/2015-08-Understanding-LSTMs/>
- Olhager, J. (2003), 'Strategic positioning of the order penetration point', *International Journal of Production Economics* **85**, 319–329.
- Olhager, J. and Rudberg, M. (2002), 'Linking manufacturing strategy decisions on process choice with manufacturing planning and control systems', *int. j. prod. res* **40**, 2335–2351.
- Olhager, J., Rudberg, M. and Wikner, J. (2001), 'Long-term capacity management: Linking the perspectives from manufacturing strategy and sales and operations planning', *International Journal of Production Economics* **69**(2), 215–225. Strategic Planning for Production Systems.  
**URL:** <https://www.sciencedirect.com/science/article/pii/S0925527399000985>
- Olhager, J. and Selldin, E. (2007), 'Manufacturing planning and control approaches: market alignment and performance', *International Journal of Production Research* **45**(6), 1469–1484.  
**URL:** <https://doi.org/10.1080/00207540600635250>
-

- 
- Olhager, J. and Wikner, J. (2000), ‘Production planning and control tools’, *Production Planning & Control* **11**(3), 210–222.  
**URL:** <https://doi.org/10.1080/095372800232180>
- Olsen, S. E. (2021), ‘The potential value of information sharing in the norwegian food supply chain’.
- Oslo-Economics (2017), ‘Etableringshindringer i dagligvaresektoren’.
- Paik, S.-K. and Bagchi, P. K. (2007), ‘Understanding the causes of the bullwhip effect in a supply chain’, *International Journal of Retail & Distribution Management* .
- Pandas (2020), ‘pandas-dev/pandas: Pandas’.  
**URL:** <https://doi.org/10.5281/zenodo.3509134>
- Parmezan, A. R. S., Souza, V. M. and Batista, G. E. (2019), ‘Evaluation of statistical and machine learning models for time series prediction: Identifying the state-of-the-art and the best conditions for the use of each model’, *Information sciences* **484**, 302–337.
- Parsa, P., Rossetti, M. D., Zhang, S. and Pohl, E. A. (2017), ‘Quantifying the benefits of continuous replenishment program for partner evaluation’, *International Journal of Production Economics* **187**, 229–245.
- Pauls-Worm, K. G., Hendrix, E. M., Haijema, R. and van der Vorst, J. G. (2014), ‘An milp approximation for ordering perishable products with non-stationary demand and service level constraints’, *International Journal of Production Economics* **157**, 133–146. The International Society for Inventory Research, 2012.  
**URL:** <https://www.sciencedirect.com/science/article/pii/S0925527314002370>
- Pavlyshenko, B. M. (2019), ‘Machine-learning models for sales time series forecasting’, *Data* **4**(1), 15.
- Pei, Z. and Yan, R. (2019), ‘Cooperative behavior and information sharing in the e-commerce age’, *Industrial Marketing Management* **76**, 12–22.
- Pettersen, I. (2013), ‘Dagligvarehandel og mat 2013’.
- Pinna, C., Galati, F., Rossi, M., Saidy, C., Harik, R. and Terzi, S. (2018), ‘Effect of product lifecycle management on new product development performances: Evidence from the food industry’, *Computers in Industry* **100**, 184–195.
- Pochet, Y. and Wolsey, L. A. (2006), *Production Planning by Mixed Integer Programming*, Springer Science & Business Media. Google-Books-ID: Uv8vn.kQZqEC.

- 
- Premkumar, G. P. (2001), Interorganizational systems and supply chain management: An information processing perspective, *in* ‘Making Supply Chain Management Work’, Auerbach Publications, pp. 387–408.
- Priyadarshi, R., Panigrahi, A., Routroy, S. and Garg, G. K. (2019), ‘Demand forecasting at retail stage for selected vegetables: a performance analysis’, *Journal of Modelling in Management* .
- Pujara, A., Pattabiraman, V. and Parvathi, R. (2022), Food demand forecast for online food delivery service using catboost model, *in* ‘3rd EAI International Conference on Big Data Innovation for Sustainable Cognitive Computing’, Springer, pp. 129–142.
- R.M. van Steenberghe, M. M. (2020), ‘Forecasting demand profiles of new products’, **139**.
- Romsdal, A. (2014), ‘Differentiated production planning and control in food supply chains’, *Thesis for the degree of Philosophiae Doctor, Norwegian University of Science and Technology* .
- Réal Carbonneau, Rustam Vahidov, K. L. (2007), ‘Machine learning-based demand forecasting in supply chains’, *International Journal of Intelligent Information Technologies* .
- Sahin, F., Narayanan, A. and Robinson, E. P. (2013), ‘Rolling horizon planning in supply chains: review, implications and directions for future research’, *International Journal of Production Research* **51**(18), 5413–5436.  
**URL:** <https://doi.org/10.1080/00207543.2013.775523>
- Saitone, T. L. and Sexton, R. J. (2017), ‘Concentration and consolidation in the us food supply chain: The latest evidence and implications for consumers, farmers, and policymakers’, *Economic Review* **102**, 25–59.
- Salomon, M. (1991), *Deterministic Lotsizing Models for Production Planning*.  
**URL:** <https://link.springer.com/book/10.1007/978-3-642-51649-8>
- Sanders, N. R. (2012), *Supply Chain Management: A Global Perspective*, George Hoffmann.
- Sargut, F. Z. and Isik, G. (2017), ‘Dynamic economic lot size model with perishable inventory and capacity constraints’, *Applied Mathematical Modelling* **48**, 806–820.
- Schoenherr, T. and Swink, M. (2015), ‘The roles of supply chain intelligence and adaptability in new product launch success’, *Decision Sciences* **46**(5), 901–936.
-

- 
- Schulze, B., Spiller, A., Theuvsen, L. et al. (2006), ‘Is more vertical integration the future of food supply chains? empirical evidence and theoretical considerations from german pork production’, *International agri-food chains and networks: management and organization, Wageningen* pp. 49–63.
- Seabold, S. and Perktold, J. (2010), statsmodels: Econometric and statistical modeling with python, in ‘9th Python in Science Conference’.
- Seaman, B. (2018), ‘Considerations of a retail forecasting practitioner’, *International Journal of Forecasting* **34**(4), 822–829.
- Shaohui Ma, Robert Fildes, T. H. (2016), ‘Demand forecasting with high dimensional data: The case of sku retail sales forecasting with intra- and inter-category promotional information’, *European Journal of Operational Research* **249**.
- Shen, W., Duenyas, I. and Kapuscinski, R. (2014), ‘Optimal pricing, production, and inventory for new product diffusion under supply constraints’, *Manufacturing & Service Operations Management* **16**(1), 28–45.
- Slack, N., Brandon-Jones, A. and Johnston, R. (2019), *Operations Management 9th ed.*, Pearson.
- Småros, J. (2004), The value of point-of-sales data in managing product introductions: results from a case study, in ‘16th Annual NOFOMA Conference, Linköping, Sweden, June’, Citeseer, pp. 7–8.
- Småros, J. (2005), ‘Information sharing and collaborative forecasting in retail supply chains’, p. 152.
- Småros, J. and Kaleva, H. (2020), ‘The complete guide to machine learning in retail demand forecasting’.
- Snyder, H. (2019), ‘Literature review as a research methodology: An overview and guidelines’, *Journal of Business Research* **104**, 333–339.  
**URL:** <https://www.sciencedirect.com/science/article/pii/S0148296319304564>
- Soni, A. and Cohen, H. (2004), ‘Successfully launching your product: getting it right’, *Handbook of Business strategy* .
- Sox, C. R., Jackson, P. L., Bowman, A. and Muckstadt, J. A. (1999), ‘A review of the stochastic lot scheduling problem1this paper is based upon work supported in part by the national science foundation under grant number dmi-9409344.1’, *International Journal of Production Economics* **62**(3), 181–200.  
**URL:** <https://www.sciencedirect.com/science/article/pii/S0925527398002473>
-



- 
- Spyros G. Makridakis, Steven C. Wheelwright, R. J. H. (2008), ‘Forecasting methods and applications’.
- Stensgård, A. E. and Hanssen, O. J. (2016), ‘Matsvinn i norge 2010-2015 - sluttrapport fra formatprosjektet’, *Østfoldforskning* .
- Stevenson, M., Hendry, L. C. and †, B. G. K. (2005), ‘A review of production planning and control: the applicability of key concepts to the make-to-order industry’, *International Journal of Production Research* **43**(5), 869–898.  
**URL:** <https://doi.org/10.1080/0020754042000298520>
- Stevenson, W. J., Hojati, M. and Cao, J. (2014), *Operations management*, McGraw-Hill Education Chicago-USA.
- Su, C.-T. and Wong, J.-T. (2008), ‘Design of a replenishment system for a stochastic dynamic production/forecast lot-sizing problem under bullwhip effect’, *Expert Systems with Applications* **34**(1), 173–180.  
**URL:** <https://www.sciencedirect.com/science/article/pii/S0957417406002661>
- Surathkal, P., Dey, M. M., Engle, C. R., Chidmi, B. and Singh, K. (2017), ‘Consumer demand for frozen seafood product categories in the united states’, *Aquaculture Economics & Management* **21**(1), 9–24.
- Swanson, D. A. (2015), ‘On the relationship among values of the same summary measure of error when used across multiple characteristics at the same point in time: an examination of malpe and mape’, *Review of Economics and Finance* **5**(1).
- Syntetos, A., Nikolopoulos, K. and Boylan, J. (2010), ‘Judging the judges through accuracy-implication metrics: The case of inventory forecasting’, *International Journal of Forecasting* **26**, 134–143.
- Takey, F. M. and Mesquita, M. A. (2006), ‘Aggregate planning for a large food manufacturer with high seasonal demand’, *Brazilian Journal of Operations & Production Management* **3**(1), 05–20.
- Tarim, S. A. and Kingsman, B. G. (2004), ‘The stochastic dynamic production/inventory lot-sizing problem with service-level constraints’, **88**(1), 105–119.  
**URL:** <https://www.sciencedirect.com/science/article/pii/S0925527303001828>
- Tavaghoof-Gigloo, D. and Minner, S. (2021), ‘Planning approaches for stochastic capacitated lot-sizing with service level constraints’, *International Journal of Production Research* **59**(17), 5087–5107.  
**URL:** <https://doi.org/10.1080/00207543.2020.1773003>
-

- 
- Tavares Thomé, A. M., Scavarda, L. F., Fernandez, N. S. and Scavarda, A. J. (2012), ‘Sales and operations planning: A research synthesis’, *International Journal of Production Economics* **138**(1), 1–13.  
**URL:** <https://www.sciencedirect.com/science/article/pii/S0925527311004907>
- Tempelmeier, H. (2013), *Stochastic Lot Sizing Problems*, pp. 313–344.
- Tiacci, L. and Saetta, S. (2009), ‘An approach to evaluate the impact of interaction between demand forecasting method and stock control policy on the inventory system performances’, *International Journal of Production Economics* **118**(1), 63–71. Special Section on Problems and models of inventories selected papers of the fourteenth International symposium on inventories.  
**URL:** <https://www.sciencedirect.com/science/article/pii/S092552730800248X>
- Tiwari, S. (2020), ‘Supply chain integration and industry 4.0: a systematic literature review’, *Benchmarking: An International Journal*.
- Tradesolution (n.d.), <https://tradesolution.no/tjenester/salgdata/>. Accessed: 2022-04-02.
- van der Vorst, J. G. (2000), ‘Effective food supply chains: generating, modelling and evaluating supply chain scenarios’.
- Van Rossum, G. and Drake, F. L. (2009), *Python 3 Reference Manual*, CreateSpace, Scotts Valley, CA.
- Verdouw, C., Beulens, A., Trienekens, J. and Wolfert, J. (2010), ‘Process modelling in demand-driven supply chains: A reference model for the fruit industry’, *Computers and electronics in agriculture* **73**(2), 174–187.
- Verdouw, C., Wolfert, J., Trienekens, J., Top, J., Van der Vorst, J. and Beulens, A. (2010), ‘Reference process modelling in demand-driven agri-food supply chains: a configuration-based framework’, *Towards effective food chains: Models and applications* pp. 225–250.
- Vergin, R. C. and Barr, K. (1999), ‘Building competitiveness in grocery supply through continuous replenishment planning:: Insights from the field’, *Industrial Marketing Management* **28**(2), 145–153.
- Viet, N. Q., Behdani, B. and Bloemhof, J. (2018), ‘The value of information in supply chain decisions: A review of the literature and research agenda’, *Computers & Industrial Engineering* **120**, 68–82.

- 
- Voss, C., Tsiriktsis, N. and Frohlich, M. (2002), ‘Case research in operations management’, *International Journal of Operations Production Management* **22**, 195–219.
- Wagner, H. M. and Whitin, T. M. (1958), ‘Dynamic version of the economic lot size model’, *Management Science* **5**(1), 89–96.  
**URL:** <http://www.jstor.org/stable/2626974>
- Wang, X. and Disney, S. M. (2016), ‘The bullwhip effect: Progress, trends and directions’, *European Journal of Operational Research* **250**(3), 691–701.
- Waters, D. (2008), ‘Inventory control and management’.
- Wei, J., Zhao, J. and Hou, X. (2019), ‘Bilateral information sharing in two supply chains with complementary products’, *Applied mathematical modelling* **72**, 28–49.
- Wemmerlöv, U. (1989), ‘The behavior of lot-sizing procedures in the presence of forecast errors’, **8**(1), 37–47.  
**URL:** <https://www.sciencedirect.com/science/article/pii/S027269638980004X>
- Wifstad, K., Jenssen, T. B., Eide, L. S., Grünfeld, L. A. and Skogli, E. (2018), ‘Konkurransen i dagligvaremarkedet - konkurranse i alle ledd’, *Menon Economics* .
- Winands, E. M. M., Adan, I. J. B. F. and Houtum, G. J. v. (2011), ‘The stochastic economic lot scheduling problem: A survey’, **210**(1), 1–9.  
**URL:** <https://www.sciencedirect.com/science/article/pii/S0377221710004170>
- Winters, P. R. (1960), ‘Forecasting sales by exponentially weighted moving averages’, *Management science* **6**(3), 324–342.
- Wood, A. (1993), ‘Efficient consumer response’, *Logistics Information Management* .
- Wright, M. J. and Stern, P. (2015), ‘Forecasting new product trial with analogous series’, *Journal of Business Research* **68**(8), 1732–1738.
- Xi, M. H., Wang, H. X. and Zhao, Q. H. (2012), Regression based integration of demand forecasting and inventory decision, in ‘Materials Science and Information Technology’, Vol. 433 of *Advanced Materials Research*, Trans Tech Publications Ltd, pp. 2954–2956.
- Yegnanarayana, B. (2009), *Artificial neural networks*, PHI Learning Pvt. Ltd.

---

Yeung, J. H., Wong, W. and Ma, L. (1998), 'Parameters affecting the effectiveness of mrp systems: A review', *International Journal of Production Research* **36**(2), 313–332.

**URL:** <https://doi.org/10.1080/002075498193750>

Yin, R. (2009), *Case study research: Design and Methods 4th ed.*, Sage Publications.

Zhang, Z. (2018), Improved adam optimizer for deep neural networks, in '2018 IEEE/ACM 26th International Symposium on Quality of Service (IWQoS)', IEEE, pp. 1–2.

Zoubir, L. (2017), 'A brief history of time series analysis'.

