

Marius Eriksen  
Mathias Espeland Trondal

# Short-term hydropower scheduling in congested areas: A novel approach employing DC power flow and grid limitations

Master's thesis in Energy and Environmental Engineering  
Supervisor: Gro Klæboe  
Co-supervisor: Stine Fleischer Myhre  
June 2022



Marius Eriksen  
Mathias Espeland Trondal

# **Short-term hydropower scheduling in congested areas: A novel approach employing DC power flow and grid limitations**

Master's thesis in Energy and Environmental Engineering  
Supervisor: Gro Klæboe  
Co-supervisor: Stine Fleischer Myhre  
June 2022

Norwegian University of Science and Technology  
Faculty of Information Technology and Electrical Engineering  
Department of Electric Power Engineering



---

## Preface

This master's thesis was completed in the spring of 2022 at The Department of Electric Power Engineering at The Norwegian University of Science and Technology (NTNU). The task was established as SINTEF Energy, Statkraft and NTNU found great interest in investigating the influence of introducing power flow equations into the short-term hydropower scheduling. The thesis marks the end of an era, as we take the step from being students to becoming electrical power engineers.

Early on we found this task to be both challenging and exciting. The relevance, given the current situation and development in the power market, made the task a rewarding experience. As the world move towards a sustainable way of living, the challenges addressed in this thesis will continue to be of importance. We hope this will be one of many thesis's investigating the topic and look forward to see the progress in the future.

We would like to address our sincerest gratitude to our supervisor and co-supervisor, Gro and Stine. The valuable input, fruitful discussions and encouragement were invaluable throughout the semester. We would also like to thank our fellow students, the strong unity and comradeship have made our time at NTNU an absolute pleasure. Last but not least, we would like to thank our parents. Without the unconditional support and encouragement we would not be where we are today. Also, the occasional additions to the food budget were much appreciated.

Trondheim, June 2022

Marius Eriksen



Mathias Espeland Trondal



---

## Abstract

This master thesis evaluates the impact of including power flow equations in the short-term hydropower scheduling algorithm. The research is conducted on a self-produced optimization model in a area with sparse transmission capacity in the power grid. A direct current approximation represents the power flow equations in the optimization model, where this entails that the properties of the power grid is included, and will affect the hydropower producers' decisions. The area of analysis, the northernmost price area in the Norwegian power market (NO4), is represented with a nodal approach due to the bottlenecks in the power grid.

The master's thesis has offered extensive and detailed work related to the development of the optimization model, as well as thorough data construction to make realistic analyzes. As information related to the hydropower plants is secret, efficient and satisfying methods had to be utilized to represent this data in a correct way. The various hydropower plants values the water in their reservoirs, which represent how they intend to produce now and in the future. This information is secret for that reason. With public water values, hydropower producers will reveal their market forecast.

A case study has been carried out on an existing, large-scale problem in the current power grid. Northern Norway experiences substantially lower area prices than the rest of Norway, due to surplus production and limited transmission in the power grid to the coupled price areas. By including the load flow equations in the short-term planning for hydropower, we will analyze whether the hydropower producers change their production pattern in our developed model. A base case, which can represent how the day-ahead market operates today, is compared to cases with limited transmission capacity to perform the analysis.

A result of the work and research done on this master's thesis is a paper submitted to The International Conference on European Energy Markets (EEM) 2022, which is one of the well established conferences in Europe. The paper is included in the Appendix. We are awaiting an answer on whether this will be approved and published at this time. The created datasets for this thesis, regarding production-discharge-curves, water values, inflow, demand and line data, has been passed on to the students who will do further research on this next year.

---

## Sammendrag

Denne masteroppgaven evaluerer virkningen av å inkludere kraftflytlikninger i den kortsiktige vannkraftplanleggingen. Forskningen og arbeidet utføres på en egenutviklet optimaliseringsmodell i et område med begrenset overføringskapasitet i kraftnettet. En likestrømstilnærming representerer kraftflytlikningene i optimaliseringsmodellen, hvor dette innebærer at egenskapene til kraftnettet er inkludert, og vil påvirke vannkraftprodusentenes beslutninger. Analyseområdet, det nordligste prisområdet i det norske kraftmarkedet (NO4), er representert på nodenivå gjennom flaskehalsene i kraftnettet.

Masteroppgaven har bydd på omfattende og detaljert arbeid knyttet til utvikling av optimaliseringsmodellen, samt grundig datakonstruksjon for å gjøre realistiske analyser. Etersom informasjon knyttet til vannkraftverkene er hemmelig, må det benyttes effektive og gode metoder for å representere disse dataene på en korrekt måte. De ulike vannkraftverkene verdsetter vannet i sine magasiner, som representerer hvordan de har tenkt å produsere nå og i fremtiden. Denne informasjonen er hemmelig av den grunn. Med offentlige vannverdier vil vannkraftprodusentene avsløre sitt prissyn på markedet.

Det er gjennomført et case-studie på et eksisterende storskalaproblem i dagens strømmnett. Nord-Norge opplever betydelig lavere områdepriser enn resten av Norge, dette på grunn av overskudsproduksjon og begrenset overføring i kraftnettet til de sammenkoblede prisområdene. Ved å inkludere lastflytlikningene i den kortsiktige planlegging for vannkraft, vil vi analysere om vannkraftprodusentene endrer produksjonsmønsteret i vår utviklede modell. Et referansescenario, som kan representere hvordan day-ahead markedet fungerer i dag, sammenliknes med scenarier hvor det er begrenset overføringskapasitet for å utføre analysen.

Et resultat av arbeidet og forskningen som er gjort på denne masteroppgaven er en artikkel sendt til den Internasjonale Konferansen om Europeisk Energimarkeder (EEM) 2022, som er en av de veletablerte konferansene i Europa. Oppgaven er inkludert i Appendix. Vi avventer svar på om dette blir godkjent og offentliggjort på nåværende tidspunkt. De utviklede datasettene for denne masteroppgaven, knyttet til produksjon-tilsig-kurver, vannverdier, tilsig, forbruk og linjedata, er overført videre til videre forskning på dette området for neste års studenter.

# Table of contents

<b>Preface</b>	<b>i</b>
<b>Abstract</b>	<b>ii</b>
<b>Sammendrag</b>	<b>iii</b>
<b>Table of contents</b>	<b>iv</b>
<b>List of figures</b>	<b>vi</b>
<b>List of tables</b>	<b>vii</b>
<b>Nomenclature</b>	<b>viii</b>
<b>1 Introduction</b>	<b>1</b>
1.1 Context . . . . .	1
1.2 Problem definition . . . . .	2
1.3 Scope of thesis . . . . .	2
1.4 Our contribution . . . . .	2
1.5 Outline . . . . .	3
<b>2 Background</b>	<b>4</b>
2.1 Literature review . . . . .	4
<b>3 Theory</b>	<b>7</b>
3.1 Power system and market . . . . .	7
3.2 Transmission system . . . . .	8
3.3 Hydropower . . . . .	8
3.3.1 Short-term hydropower scheduling . . . . .	9
3.3.2 Linear reservoir model . . . . .	10
3.3.3 Linear plant model . . . . .	11
3.3.4 Objective value . . . . .	12
3.3.5 Water value estimation . . . . .	14
3.4 Optimal power flow . . . . .	14
3.4.1 DC Optimal Power Flow . . . . .	14
3.4.2 Multi-period DC OPF . . . . .	15
3.4.3 AC load flow . . . . .	16
3.4.4 DC load flow . . . . .	16
3.4.5 Effect of assumptions on solution . . . . .	17
3.5 Different solutions to the problem . . . . .	17
3.5.1 Available transmission capacity (ATC) . . . . .	17
3.5.2 Flow-based market coupling (FBMC) . . . . .	17
<b>4 Model and methodology</b>	<b>19</b>
4.1 Model presentation . . . . .	19
4.1.1 Objective function . . . . .	19
4.1.2 Restrictions . . . . .	20
4.2 Method . . . . .	20
4.2.1 Topology . . . . .	21
4.2.2 Hydropower plants . . . . .	21
4.2.3 Nodes . . . . .	22



---

4.2.4	Case study . . . . .	22
4.2.5	Optimization cases . . . . .	23
4.2.6	Software . . . . .	25
<b>5</b>	<b>Data construction</b>	<b>26</b>
5.1	PQ-curves . . . . .	26
5.2	Inflow . . . . .	27
5.3	Water values . . . . .	28
5.4	Start reservoir levels . . . . .	32
5.5	Line data . . . . .	32
5.6	Demand . . . . .	33
<b>6</b>	<b>Results</b>	<b>36</b>
6.1	Base case . . . . .	36
6.2	Case 1 - Ofoten bottleneck . . . . .	37
6.3	Case 2 - East to west bottleneck in Finnmark . . . . .	38
6.4	Quantitative results . . . . .	39
6.5	Nodal prices and objective values . . . . .	40
<b>7</b>	<b>Discussion</b>	<b>42</b>
7.1	Optimization model and data . . . . .	42
7.2	Case study . . . . .	42
7.3	Value for market participants . . . . .	43
7.4	Effects of different congestion management methods . . . . .	44
7.5	Nodal and zonal approach . . . . .	44
7.6	Future work . . . . .	45
<b>8</b>	<b>Conclusion</b>	<b>47</b>
	<b>References</b>	<b>48</b>
	<b>Appendix</b>	<b>i</b>
<b>A</b>	<b>Journal publication - EEM 2022</b>	<b>i</b>

## List of Figures

3.1	Parts of the price areas in the European market. Adapted from: [20]. . . . .	7
3.2	Flow chart of hydropower scheduling and coupling . . . . .	9
3.3	Representation of discharge, spillage/bypass and inflow in hydropower production	10
3.4	Relation between production, $P$ , and discharge, $Q$ . Adapted from: [28] . . . . .	11
3.5	Comparison between ATC and FBMC . . . . .	18
4.1	Nodal representation of parts of the Nordic system . . . . .	21
4.2	Visualization of the restricted line in Case 1 . . . . .	24
4.3	Visualization of the restricted line in Case 2 . . . . .	24
5.1	Aggregated PQ-curve used in the model . . . . .	26
5.2	Capacity factor method of computing water values . . . . .	30
6.1	Power produced at each hydropower plant with no capacity restrictions . . . . .	36
6.2	Power produced at each hydropower plant with capacity restrictions between north and south in NO4 . . . . .	37
6.3	Power produced at each hydropower plant with capacity restrictions between east and west in Finnmark . . . . .	38
6.4	Production in all optimization cases . . . . .	39
6.5	Production in all optimization cases . . . . .	39

## List of Tables

2.1	Literature review . . . . .	6
4.1	Numbering and content at the different nodes . . . . .	22
4.2	Composition of the different cases . . . . .	25
5.1	Water values for the different hydropower plants . . . . .	31
5.2	Weighted nodes for consumption data . . . . .	34
5.3	Weighted nodes for consumption data . . . . .	35
6.1	Nodal prices and objective value for all three cases . . . . .	40
6.2	Total costs and nodal prices for the different cases . . . . .	41

..

## Nomenclature

### Abbreviations

- AC** Alternating current
- ATC** Available transfer capacities
- DC** Direct current
- EEM** European Energy Market
- FBMC** Flow-based market coupling
- LP** Linear programming
- MCP** Mixed complementarity problem
- MILP** Mixed linear integer problem
- MP OPF** Multi-period optimal power flow
- NO4** Spot price area in northern Norway
- NVE** The Norwegian Water Resources and Energy Directorate
- OPF** Optimal power flow
- PQ** Production-discharge
- SHOP** Short-term Hydropower Optimization Program
- STHS** Short-term hydro scheduling
- TSO** Transmission System Operator
- WV** Water value

### Sets

- $\mathcal{K}$  Set of segments by linearizing PQ-curve, where  $\mathcal{K} \in \{1, 2, \dots, k\}$
- $\mathcal{M}$  Set of interconnection between nodes in the system, where  $\mathcal{M} \in \{1, 2, \dots, m\}$
- $\mathcal{N}$  Set of nodes in the system, where  $\mathcal{N} \in \{1, 2, \dots, n\}$
- $\mathcal{S}$  Set of plants in the system, where  $\mathcal{S} \in \{1, 2, \dots, s\}$
- $\mathcal{T}$  Set of time steps of one hour, where  $\mathcal{T} \in \{1, 2, \dots, t\}$

### Parameters

$\Delta n_t$	Number of units started or stopped in time period $t$ .
$f$	Conversion factor between $[m^3/s]$ and $[Mm^3/h]$ . Time step of one hours gives $f = 0.0036$ .
$B$	Susceptance matrix. $[\Omega^{-1}]$
$c_p$	Power generation. $[MW]$
$C_{ap}$	Start-up/shut-down cost of for a number of generating units. $[NOK]$
$C_{i,s}$	Start-up cost of unit $i$ in plant $s$ . $[NOK]$
$e_{n,k}$	Energy equivalent for linear segment $k$ , $\{k \in \mathcal{K}\}$ , at node $n$ , telling how much power one can get from each cubic meter of water through the turbine. $[kWh/m^3]$
$I_{t,n}$	Inflow at node $n$ in time step $t$ . $[m^3/s]$
$k_n$	Water value for reservoir at node $n$ . $[NOK/Mm^3]$
$L_t$	Total demand in time step $t$ . $[MW]$
$MC_n$	Marginal cost of production at node $n$ . $[NOK/MW]$
$p_n(d_t)$	Power loss function for $n$ units in operation at hour $t$ .
$P_{t,ij}^{max}$	Maximum power flow in line from node $i$ to node $j$ in time step $t$ . $[MW]$
$Q_{t,n,k}^{max}$	Maximum discharge level for linear segment $k$ , $\{k \in \mathcal{K}\}$ , at node $n$ in time step $t$ . $[m^3/s]$
$Q_{t,n}^{min}$	Minimum discharge level at node $n$ in time step $t$ . $[m^3/s]$
$V_{t,n}^{max}$	Maximum reservoir level at node $n$ in time step $t$ . $[Mm^3]$
$V_{t,n}^{min}$	Minimum reservoir level at node $n$ in time step $t$ . $[Mm^3]$
$x_{ij}$	Reactance on line from node $i$ to node $j$ . $[\Omega]$

### Variables

$\alpha_{t,n}$	Future expected income from having water left in the reservoir at the end of the scheduling period $t$ for node $n$ . $[NOK]$
$\delta_i$	Phase angle at sending node $i$ . $[rad]$
$\delta_j$	Phase angle at receiving node $j$ . $[rad]$
$\mu_{i,s,t}$	Decision variable, taking the value 1 if unit $i$ in plant $s$ is started in period $t$ .
$e_{t,n}$	Energy sold to the market in period $t$ for a given node $n$ . $[MW]$
$p_{t,ij}^G$	Power flow from node $i$ to node $j$ in time step $t$ . $[MW]$
$p_{t,n,k}$	Power production for linear segment $k$ , $\{k \in \mathcal{K}\}$ , at node $n$ in time step $t$ . $[MW]$
$p_{t,n}^s$	Market price in period $t$ for a given node $n$ . $[NOK/MWh]$

$p_{t,n}^D$	Power consumption at node $n$ in time step $t$ . [MW]
$p_{t,n}^G$	Power production at node $n$ in time step $t$ . [MW]
$q_{t,n,k}$	Discharge for linear segment $k$ , $\{k \in \mathcal{K}\}$ , at node $n$ in time step $t$ . [ $m^3/s$ ]
$q_{t,n}$	Discharge from the reservoir at node $n$ in time step $t$ . [ $m^3/s$ ]
$s_{t,n}$	Spillage from the reservoir at node $n$ in time step $t$ . [ $m^3/s$ ]
$v_{t,n}$	Reservoir level at node $n$ at the end of time step $t$ . [ $Mm^3$ ]

# 1 Introduction

## 1.1 Context

The Norwegian power system will experience challenges with the increasing penetration of renewable energy sources, as many parts of the grid is not dimensioned for the increased power production. The growing need entails major challenges for how capacity is to be allocated between the price zones. To obtain a sustainable society as stated in "The Paris Agreement", emissions need to be reduced drastically. This implies that the importance of renewable energy sources such as hydropower will continue to increase in the future. The goal of the agreement is to limit the increase in temperature, due to global warming, to below 2 degrees Celsius, preferably as low as 1.5 degrees compared to pre-industrial levels [1]. To reach this goal, the participating countries aim to be climate neutral by mid-century, meaning the green shift is imminent.

The Norwegian government has bound itself to the goals set by the agreement, dictating the cuts in emission. The electrification of the society is one of the main tools to reach the emission cuts within the brand years 2030 and 2050. By 2050, Norway is going to be climate neutral, meaning a cut of 90-95% in emissions by that time [2]. The electrification of industry, the transport- and petroleum sector will impose a significant increase in electricity demand. NVE conducted an analysis on how full electrification on some parts of the industry would require additional investments and upgrades in the power grid, called "Elektrifisering av landbaserte industrianlegg i Norge". According to the analysis, NO2 (one of the price zones in the Norwegian power system) would experience a great increase in demand should the evaluated facilities be electrified, adding to the unbalance of power in the system [3]. These challenges will amplify the already experienced difficulties regarding bottlenecks in the grid. The need for an effective electrification implies that these challenges will only increase in the future, highlighting the imminent need for new and effective solutions. Upgrading the power grid is a viable solution to the problem, but at the same time it is an expensive and time consuming measure. Therefore, optimizing the utilization of the existing power grid could prove a more cost efficient solution in the meantime.

The introduction of renewable energy sources into the power mix has been facilitated by targeted measures, in order to reach the goal on emissions. Renewable energy sources introduce uncertainty into the already congested, and at times, overloaded power grid. Issues regarding bottlenecks are already posing a challenge in the power grid, meaning introducing volatile, weather depending energy sources could prove a difficult task. The Norwegian power production has the highest share of renewable electricity in Europe, almost completely emission free [4]. The main source of power is hydropower, with a share of approximately 89%, making it fundamental in the Norwegian power mix. However, today the short-term production planning for hydropower is conducted without consideration for the actual power flow and capacity present in the power grid. Keeping within the limits of the transmission grid is of great importance for the security of the whole system, and the increase in both installed wind power and solar power, could lead to infeasible production scheduling. Therefore, it is important that production planning takes into account the utilization of the grid to ensure security of supply.

The price differences seen in the power system today is usually a result of bottlenecks. Bottlenecks occur when the desired power flow from a low price area to a high price area is infeasible, due to the insufficient capacity between the regions. The issue is commonly seen in the Norwegian power grid, between the northern price zones and the southern price zones. The northernmost price zone of Norway, NO4, has access to large amounts of cheap hydropower as there exists a power surplus due to the low demand in the area. In an optimal power grid, this power would be transferred through the transmission grid further south, where the majority of the demand is located. During the fall of 2021, there was unusual low reservoir levels in the south of Norway. This resulted in an increased demand of power that needed to be transferred from the north,

creating bottlenecks and increased water value in the south, which ultimately lead to higher electricity prices. The price differences seen in the Norwegian power market is due to the market mechanism dealing with congestion in the grid. If congestion is expected, the market will be divided into temporary markets where supply and demand are met internally, causing a local market price [5].

Statnett SF is the transmission system operator (TSO) in Norway and is a state-owned company that builds, operates and develops the Norwegian power system. In October 2019, they investigated the potential benefits of upgrading the capacity in different parts of the Norwegian power grid, to see how it would affect the socio-economic welfare. The results from the analysis lead to the conclusion that even if power flows were increased, the market would still experience price differences between regions. Also, the market value achieved by upgrading the grid would not only accrue Norwegians, but a big portion would also accrue foreign countries, should the price differences decrease significantly [6].

## 1.2 Problem definition

Infeasible power dispatch occur when the desired production planning is limited by the power grid. The issue with neglecting the technical aspects present in the grid is that many solutions to the dispatch problem would have to be rescheduled. Over- and underproduction would occur frequently, making the need for additional regulation of production subsequently. This implies a two-step process, which could result in a decrease in socio-economic welfare. The aim of this thesis is to investigate the influence of taking these technical aspects into consideration when conducting the production planning, in other words: How would the production pattern look when STHS accounts for the limitations present in the power grid?

## 1.3 Scope of thesis

The purpose of the analysis conducted in this thesis, is to investigate the influence of including power flow equations in the short-term hydropower scheduling. The case study in this thesis aims to illustrate which hydropower plants that will experience variations in the amount of produced power, as a result of additional constraints in the network. The simulations are done over a period of 168 time steps. Although this thesis use assumptions and simplifications regarding both hydropower plants and the power grid, it gives a thorough assessment on how the technical aspect in the power grid and production costs of the hydropower producers influence each other. This is done by modelling the northernmost price zone in Norway (NO4) and using realistic data on hydropower plants and grid topology, together with the developed optimization model. The main topics lays the foundation of this thesis. The optimization model developed are based on STHS and DC OPF, which is presented in Chapter 3.

## 1.4 Our contribution

In this thesis we have developed a new algorithm for the short-term hydropower scheduling (STHS), by including the standard method for STHS and introducing power flow equations to the optimization model. As the literature review in Chapter 2 highlights, previous research on STHS has not heavily weighted power flow in the aim of optimizing production. Radial or highly simplified systems have previously been analysed in [7–11], this thesis takes this a step further, by modelling the northernmost price zone in Norway (NO4). The work done in this thesis aims to investigate deeper into the influence power flow equations and grid topology have on the production planning for hydropower producers. The motivation behind the thesis is the large fluctuations in area prices, due to the bottlenecks seen in the Norwegian power grid today, and the possibility of hopefully alleviating the system of these issues. Also, facilitating for better



utilization of the water resources available in the surplus areas in the north, by maximizing the value of the water in the reservoir(s). An overview of our contributions is presented below:

- Developed a new optimization model for STHS.
- Modelled a price zone to conduct an analysis on a deeper level than previous research.
- Included the bottlenecks in the production planning, to see the effect on the hydropower producers.
- Developed a general, realistic, large-scale optimization model based on an existing problem in the power market.

## 1.5 Outline

The thesis consists of eight chapters with the content listed below:

**Chapter 1 - Introduction** introduces the thesis with relevant information regarding today's situation and challenges in the power market. The contribution, scope and problem definition are further introduced here.

**Chapter 2 - Background** gives insight in how STHS combined with OPF has been conducted in previous studies.

**Chapter 3 - Theory** provides the theoretical background and depth for the methods used to build the developed model. The majority of the theory presented is either reused or written with inspiration from the project task written by the authors (unpublished work [12]).

**Chapter 4 - Model and methodology** describes the mathematical optimization model developed and utilized in the optimization, as well as presenting the case study of the thesis, NO4, together with the optimization cases of the analysis.

**Chapter 5 - Data construction** explains how the data used in the optimization model is constructed and possible shortcomings by the construction methods utilized.

**Chapter 6 - Results** contains the most important results of the analysis, highlighting the aspects of interest.

**Chapter 7 - Discussion** interprets the presented results and highlights how the power flow will influence the production pattern. Additionally simplifications and assumptions made are discussed. The benefit from utilizing the optimization model are also evaluated. The discussion ends with possibilities and challenges in the presented analysis.

**Chapter 8 - Conclusion** summarizes the main findings of the thesis.

**Appendix** includes supplementary information, where especially the paper delivered to the European Energy Market Conference 2022 is of interest.

## 2 Background

This chapter presents how state of the art hydropower planning with grid constraints included has been implemented in previous articles and studies. The evaluated studies vary in terms of objective function, modeling of restrictions and topology. Research combining STHS together with power flow equations in an extended way is limited, therefore, studies considering highly simplified systems are included. The systems often analyze a radial network, neglecting the attributes of a meshed power system. The coordination between wind- and hydropower utilities is a typical research area of the combined STHS - OPF model. The reviewed papers include objectives, such as, minimizing wind power curtailment and maximizing the overall revenue. Nodal and zonal pricing models are reviewed, together with coordination and management of congestion problems. These articles have inspired the objective of this report, and laid the foundation for further research.

### 2.1 Literature review

Research that combines a detailed network topology in a DC approximation with short-term planning of hydropower, have not been studied widely. The Norwegian government has presented plans for 30 GW of power from offshore wind, which will correspond to about 140 TWh annually [13]. This corresponds to almost the annual power production in Norway, where the majority of this share comes from hydropower (around 89 %) [14]. New onshore wind power projects are being evaluated continuously, but the best locations for onshore wind power are in areas with insufficient grid capacity. The Norwegian power grid is unable to handle the increased amount of power, at the same time as this unregulated power must interact with the hydropower. If we take future plans into account, the research must also focus on including grid topology in the short-term planning for hydropower, especially as more wind power will affect how the production planning will look in the future.

In [7], a combination of hydropower and wind power were investigated. The purpose of this study is to reduce wind power curtailments in a coordinated case with hydropower, where the hydropower producer has priority on transmission capacity. The coordinated case resulted in increased revenues for both utilities, and a reduced wind power curtailment of 75 %. The future value of storing water in the reservoir and power grid attributes were, however, not assessed.

Ref. [8] looks at how the implementation of a more detailed network and load flow calculations (Kirchhoff's loop rule) of the spot price will give more efficient price signals. A simplified zonal pricing scheme is compared to optimal nodal and zonal pricing. Compared to the unconstrained case, an optimal nodal pricing with security cut constraints (total flow over a line, N-1 security) is the only case that is feasible. They are comparing the nodal pricing with and without security cut constraints, where the case without security cut constraints only looks at thermal capacity at a specific line. As the thermal capacity is decreased from 100 % to 70 %, the total surplus is decreasing, but the solution becomes more feasible. The cost of infeasibilities is not considered, and the future value of water is also not included in the bid curves, which gives a poor visualization of the effect that the various modeling methods have on the total costs.

In [9], the authors address the problems with a zonal pricing model to deal with bottlenecks, as implemented in the Norwegian power market. They discuss the impact a fixed number of zones have, compared to flexible zonal pricing to handle bottlenecks, and if zonal pricing really is a good enough simplification of optimal nodal pricing to manage congestion. Two nodes with different prices in optimal dispatch should belong to different zones, and the way of allocating nodes to zones in a meshed network, to minimize loss of social surplus, is examined. This paper includes restrictions where nodal prices in a given zone are equal, but this can lead to difficulties when consumption or generation at a node reaches zero. Kirchhoff's loop rule is implemented

to show the power grid attributes, but no hydropower production is included.

Ref. [10] develops the model presented in [9], and looks at the Nordic power market, where better utilization of the capacity of the transmission grid is investigated. The Nordic power market is modelled in a simplified manner, and they show that the lack of coordination of congestion management results in additional costs. A more detailed power grid and realistic data could verify this more accurately. A better utilization of the actual grid is achieved when the actual bottlenecks forms the basis for the definition of the price areas. This reduces the "indirect" congestion management by the system operator (TSO), as they move the internal bottlenecks to the limits between the existing price areas. The actual bottlenecks defines the price areas, which can reduce the price differences. Kirchhoff's loop rule is implemented to show the power grid attributes, but no hydropower production is included.

One of the latest models presented for combining wind production with existing reservoir hydropower production in northern Norway with low grid capacity, is presented in [11]. A simulation case was compared with an optimization model, where the optimization model (bilateral power agreement in addition to the grid regulations by NEM) removed the wind power curtailments and increased the social surplus. The simulation case resulted in periods with wind power curtailments and unused transfer capacity, and a bilateral power agreement in the optimization model solved this. There was only one line from the power production of hydro and wind to the load, which is not entirely representative. In addition, a number of assumptions were made related to the hydropower data, and more wind power scenarios should have been assessed.

Ref. [15] introduces a pricing model for an electricity market which combines a nodal and zonal pricing scheme to deal with congestion problems. The model does not include any hydropower production at the 13 nodes in the test system, and production is determined by marginal costs at the different nodes.

Ref. [16] presents a mixed complementarity problem (MCP) for obtaining a one-stage solution to ensure balance between submitted bids and cleared quantities, and a resulting price. By using mixed complementarity, different prices within the same zone are obtained, and the problem is thus non-linear, and therefore not possible to solve as a LP. The authors do not include hydropower production, but a DC approximation to the MCP is also considered.

A large-scale hydrothermal dispatch model for spot pricing in the Brazilian power system is presented in [17]. As the number of hydropower plants in Brazil are significant, the hydropower constraints is very complex and detailed in this model. The model presented is the one used to determine the weekly spot prices in Brazil. The model shows that a convergence towards optimality and feasibility is possible, with a piecewise linear representation of the nonlinear aspects in the model.

The paper presented in [18] shows the dynamics of a coupled European power market. This paper investigates the case of high wind power penetration and both zonal and nodal pricing scheme. High wind penetration from Germany will affect both Germany and Poland in a positive manner, even though Germany applies zonal pricing and Poland applies nodal pricing. The zonal pricing keeps the cheap wind power within the country, while the nodal pricing in neighbouring areas entails that a large amount of unscheduled wind power enters Poland in the north, where the demand is higher than in the south. This helps with network congestion in Poland, and reduces re-dispatching and increases the congestion rent. The paper utilized a DC approximation, but no hydropower production was assessed.

Table 2.1: Literature review

Ref.	Title	Authors	Objective
[7]	Hydropower planning coordinated with wind power in areas with congestion problems for trading on the spot and the regulating market (2009)	Julia Matevosyan Magnus Olsson Lennart Söder	Minimize wind power curtailments
[8]	Simulation of congestion management and security constraints in the Nordic electricity market (2012)	Endre Bjørndal Mette Bjørndal Victoria Gribkovskaia	Maximize social welfare
[9]	Zonal Pricing in a Deregulated Electricity Market (2001)	Mette Bjørndal Kurt Jörnsten	Maximize social surplus
[10]	Benefits from coordinating congestion management - The Nordic power market (2007)	Mette Bjørndal Kurt Jörnsten	Maximize social surplus
[11]	Optimal Utilisation of Grid Capacity for Connection of New Renewable Power Plants in Norway (2021)	Viljar S. Stave et al.	Minimize wind power losses
[15]	Nodal Pricing in a Coupled Electricity Market (2014)	Endre Bjørndal Mette Bjørndal Hong Cai	Maximize social welfare
[16]	Balancing Supply and Demand Under Mixed Pricing Rules in Multi-Area Electricity Markets (2011)	Andreas G. Vlachos Pandelis N. Biskas	Maximize social welfare
[17]	Short/Mid-Term Hydrothermal Dispatch and Spot Pricing for Large-Scale Systems - the Case of Brazil (2018)	André Luiz Diniz et al.	Minimize operational costs
[18]	Hybrid pricing in a coupled European power market with more wind power (2018)	Endre Bjørndal et al.	Maximize social welfare

This chapter has investigated different approaches for power market clearing. The objectives of the studied articles include minimizing operational costs and wind power loss in addition to maximizing social welfare, as seen in Table 2.1. However, the previous studies all focus mainly on the economical aspect of clearing the market. A few studies include radial systems, which are highly simplified, to account for the technical aspect of the power grid and power flow. Neglecting the attributes of the power system, implies that many cases will suggest infeasible solutions for the market clearing, as the dispatch in reality is limited by the possibilities in the nearby power grid. Thus, a meshed power grid with the attributes of a realistic power grid is yet to be included in these type of studies.

### 3 Theory

This chapter presents a thorough review of the theory which lays the basis for the model built and developed in the thesis. The theory is an extended section written with inspiration from the unpublished project task [12], fulfilled last semester.

#### 3.1 Power system and market

Norway is a part of the coupled Nordic power market together with Sweden, Denmark and Finland, which is also integrated in the European power market through foreign cables to Germany, The Netherlands, Estonia, Lithuania, Latvia, Poland and Russia [19]. The North Link and North Sea Link cables to Germany and the United Kingdom, respectively, were put into operation during 2021. In this market, called Nord Pool, large volumes of power are being bought and sold, where the prices for each hour in the following day are scheduled. As electric power is poorly suited for storage, balance between consumption and production is required at all times. The system price is determined by the equilibrium between supply (the producers announce how much they want to produce at a given price level) and demand (the consumers report how much they want to consume at a given price level) in the day-ahead market. This price is a theoretical price, as the system price does not take the bottlenecks into account. As seen in Figure 3.1, the Norwegian power market is divided into five price areas (NO1, NO2, NO3, NO4 and NO5). These five price areas are formed due to the bottlenecks in the power grid, where certain areas have power surplus, while others have power deficit. Areas with power surplus need to export power to deficit areas, and when the grid restrictions entails that not all power can be transferred, there will be price differences. As NO4 is an area with a lot of excess power, and limited transmission capacity out of the area, there is normally much lower prices here than the other price areas. This makes NO4 an area of interest.

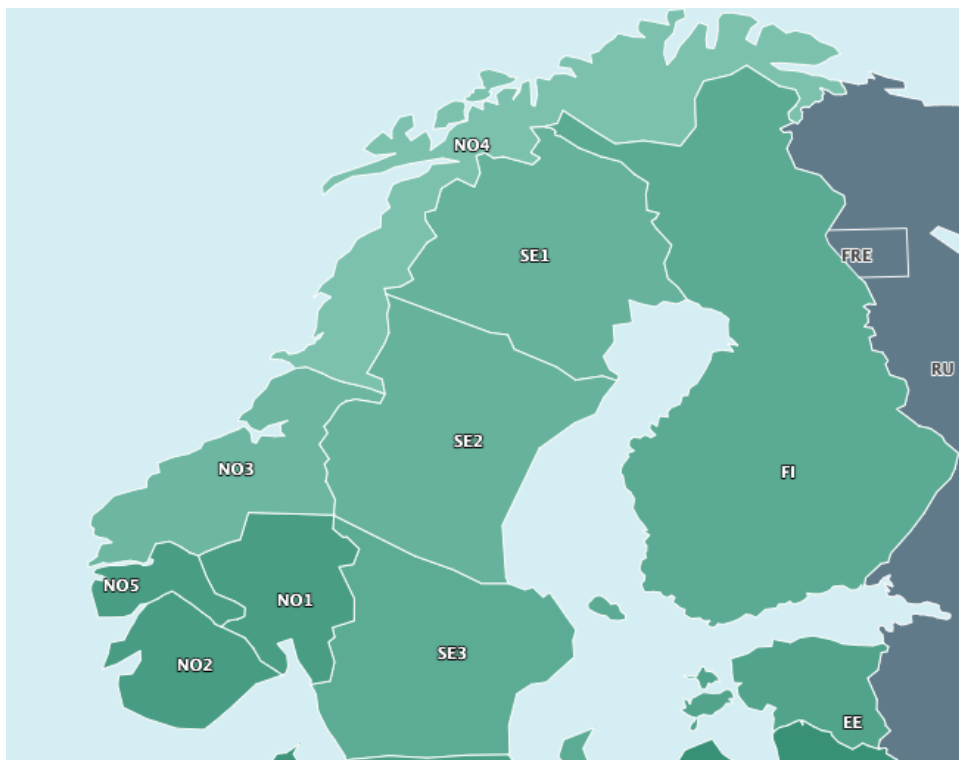

Figure 3.1: Parts of the price areas in the European market. Adapted from: [20].

### 3.2 Transmission system

The transmission grid can be characterized as the highway in the Norwegian power system where the high voltage lines connect all counties to a common marketplace for trading. The grid operates on different voltage levels where 300 kV and 420 kV are the most common, and in some cases 132 kV. The transmission grid also contains the connections to neighboring countries allowing for cross-country trading [21].

The total demand in the power system increases with the ongoing electrification. The demand side experiences an increase in electrification of industry which will lead to an increased load on the transmission grid [22]. The current grid might not be able to handle the increasing power flows needed to cover the load obligation in the system. Statnett is responsible for operating the Norwegian transmission grid and ensuring security of supply. The plan laid out in the report called “Nettutviklingsplan 2021” highlights their expectations on increased demand and investments needed in the power grid [23]. Statnett also acknowledge the importance of renewable distributed energy sources which will cover a great portion of the increased demand. These developments will be time consuming and, therefore, it is important that simultaneously the capacity of the grid is utilized in the best possible way. The main power source in Norway is hydropower and as of today the production planning is still done without consideration of the grid topology, thus including the grid topology could prove an efficient way to map out potential bottlenecks and areas of concern. Nevertheless the general opinion is that to be able to deal with the increased amount of power consumed, the system needs upgrading and new investments together with market and system measures.

One of the measures considered is to split NO4 into two parts. By splitting NO4, the the assumed increased congestion in the northern part of the zone can be avoided [24]. The capacity of the connections to NO4 which can be seen in fig() are together good. Despite this, the grid is not utilized to its full potential as skewed loading of these transmission lines prevents it. The situation is expected to get worse in the future due to the increasing penetration of wind power in the system as well as difficulties with predicting the location of the producing units within the area. The size of NO4 is according to Statnett a challenge as they need to predict the distribution of generation between the northern and the southern part of the zone, to be able to deal with the congestion. Altogether, splitting the bidding zone presents itself as a beneficial solution for the system operation [24].

### 3.3 Hydropower

In the transition to a society with a large integration of renewable energy such as solar and wind power in the energy mix, the interaction between the renewable energy sources become more important, and therefore will hydropower play an important role in ensuring this transition. Hydropower has created great values for the Norwegian society since its introduction at the end of the 19Th century, and it will continue to do so. The role of hydropower as a base load since its beginning has formed these values, and hydropower must be developed to adapt to the changes that include a lot of wind and solar power in the future, and thus contribute with adjustable power in uncertain times. In Norway, hydropower contributes with flexibility and stability in the power supply from short (seconds/minutes) to long (weeks/months) scheduling periods. This service is covered with coal- and gas power in Europe.

Wind and solar power are volatile energy sources with limited flexibility and storability functions. Hydropower contains all the features wind and solar power lacks, with excellent opportunities to store water in the reservoir, in addition to being flexible with up- and down-regulation due to sudden changes in load or faults in the power grid. The countries in Europe must integrate more renewable energy into their existing production mix to achieve the climate goals set in the Paris Agreement. Norway’s role with regulating hydropower in interaction with these more

uncertain energy sources will therefore play an important role. Norway can take on the role as Europe's large battery with hydropower with full reservoirs [25], rather than the coal- and gas power plants that are used today. Detailed hydropower modeling in collaboration with other energy sources is therefore essential to focus on in the future, to achieve the goal of limiting the average global temperature increase to  $< 2\text{ }^\circ\text{C}$  [26].

### 3.3.1 Short-term hydropower scheduling

The short-term hydropower scheduling ranges from a few days to a couple of weeks, with time steps of minutes or hours. Short-term hydropower scheduling is a model related to the functioning of the market, where producers and consumers submit offers and bids to determine the supply and demand for the following day, in addition to the price which balances supply and demand.

The coupling between the water values from aggregated reservoir levels in the long-term model to the water values from each reservoir in the short-term model is important, and the seasonable scheduling model obtains these values. As the long-term model provides boundary conditions for the shorter ones, and due to the complexity of the long-term model (modeling of the uncertainty), it can be difficult to represent every model with the same principles when the degree of detail is varying. The short-term model needs to include all relevant details for the daily operation, so the coupling between from the long-term model to the shorter ones is crucial. The flow chart representing the coupling between the different scheduling models is represented in Figure 3.2:

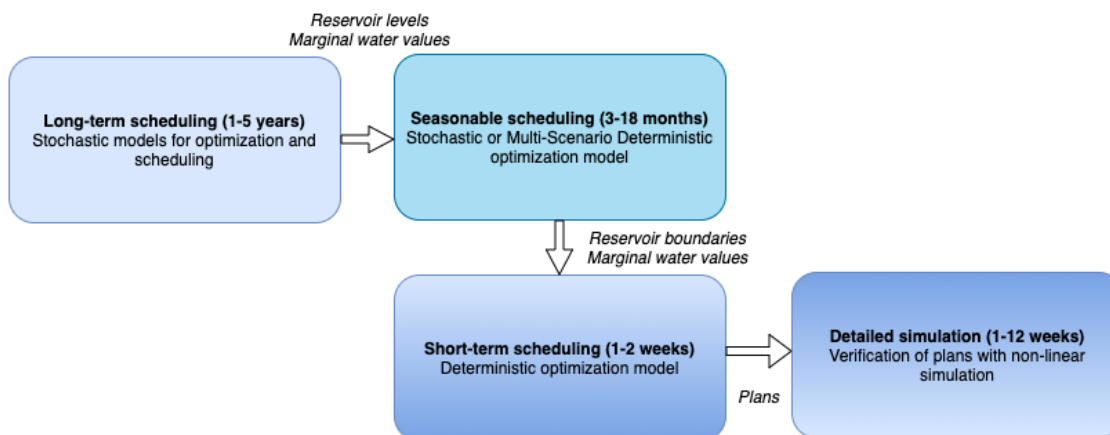

Figure 3.2: Flow chart of hydropower scheduling and coupling

By obtaining the water values and reservoir level for the individual reservoirs one can use the results as border conditions for the short-term scheduling, as:

1. **Volume coupling:** The reservoir levels at the end of the short-term period are fixed.
2. **Price coupling:** The water values from the seasonable model is used for the individual reservoirs.

These two coupling methods are the major ones used between a long-term and short-term model. Both coupling methods have their advantages. The volume coupling is unrealistic in a market-based system since it is impossible to move the discharge between different periods, and in cascaded reservoir systems, where the downstream value is dependent on the upstream value, is it hard to achieve consistency between the endpoints [27]. One advantage by using this model is more flexibility regarding mathematical models used for solving the short-term problem. The price coupling method, by setting the water value at the end of the scheduling period, provides a

more comprehensive model. One alternative solution is to describe the water value as a function of the reservoir level, and the discharged volume is then also a function of the market prices in the bidding period [27]. This relationship gets non-linear, and a linear approximation for the concave function is used to represent the water value as linear. Increased volume in the reservoir will decrease the water value due to risk of spillage, and a number of linear cuts are implemented to express the expected value of a marginal change in reservoir level.

The major components building up the short-term model, and thus also the restrictions, consists of balance in reservoir level, supply and demand, as well as technical aspects of the power plants. The reservoir level is at all times balanced with spillage/bypass, inflow and discharge from/to the given reservoir, as shown in Figure 3.3:

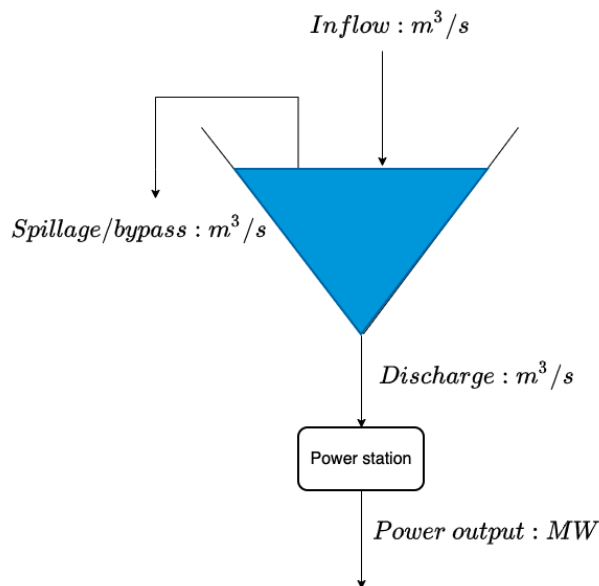

Figure 3.3: Representation of discharge, spillage/bypass and inflow in hydropower production

Furthermore, there must be balance between power produced from the hydropower producer and power sold to the market, as the hydropower producer participates in the day-ahead market (spot market). In more complex systems, where other energy systems can be integrated with hydropower, the number of decisions in the model will increase. Other types of production, especially wind and thermal power, are typically integrated in the same model as the short-term scheduling model. This increases the complexity of the system, as a producer has more variables to take into account when the power is sold to the market.

### 3.3.2 Linear reservoir model

The linear reservoir model is thoroughly presented in Section 4.1, where it is presented in combination with the load flow restrictions, but the most important assumptions are introduced here.

As stated in Section 3.3.1 is the reservoir level balanced through spillage/bypass, inflow and discharge. This reservoir level is denoted as  $v_{t,n}$ , which is the reservoir level at node/reservoir  $n$  at the end of time step  $t$ . In addition to keeping the reservoir level between its minimum and maximum level, a link between the reservoir levels is needed between two consecutive time steps. As the short-term model takes the whole scheduling period (e.g. every hour for a day) into account, a coupling between the time periods is required, since the model is going to take decisions for the whole scheduling period. The initial reservoir level in time step  $t$  is equal to



the final reservoir level in the previous time step  $t-1$ . The reservoir balance is then given by the net flow into the reservoir, which gives the difference between the initial and final reservoir, as:

$$v_{t,n} = v_{t-1,n} + f \cdot (I_{t,n} - q_{t,n} - s_{t,n}) \quad (3.1)$$

where:

- $f$ : Conversion factor between  $[m^3/s]$  and  $[Mm^3/h]$
- $I_{t,n}$ : Inflow to reservoir  $n$  in time step  $t$ . This is a deterministic value in  $[m^3/s]$ .
- $q_{t,n}$ : Discharge from reservoir  $n$  in time step  $t$  in  $[m^3/s]$ .
- $s_{t,n}$ : Spillage from reservoir  $n$  in time step  $t$  in  $[m^3/s]$ .

### 3.3.3 Linear plant model

Every node with hydropower has to include a power station, which is represented by its relationship between discharge through the turbines,  $q_{t,n}$  and power production,  $p_{t,n}$ . A power station is here represented as one unit, even though it could be several units. The power production is calculated as:

$$p = \frac{1}{10^6} \cdot q \cdot \gamma \cdot g \cdot H(q) \cdot \eta(q) \quad [MW] \quad (3.2)$$

where:

- $\gamma$ : Water density, 1000  $[kg/m^3]$
- $g$ : Gravity acceleration, 9.81  $m/s^2$
- $H(q)$ : Net plant head. Function of  $q$  because of head losses in tunnels. An average value is often used.  $[m]$
- $\eta(q)$ : Plant efficiency. Function of  $q$ , but often the point with highest efficiency for the given turbine type is used.

As stated above, both the net head and efficiency depend on the discharge, and therefore are the relationship between discharge,  $q$ , and production,  $p$ , non-linear and non-concave, as shown in Figure 3.4:

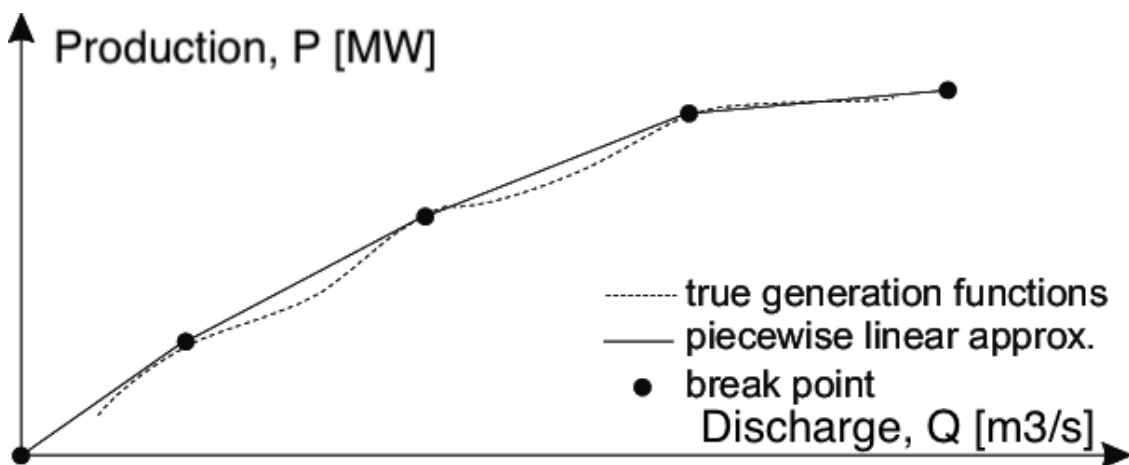

Figure 3.4: Relation between production,  $P$ , and discharge,  $Q$ . Adapted from: [28]

In short-term hydropower scheduling for a time horizon within 2 weeks, with high net head and low discharge, it is reasonable to assume that the net head is independent of the discharge, so that the model can be linearized with segments representing the power-discharge (PQ) - curve. A PQ-curve shows the relation between production and discharge for a given hydropower, and the relation is originally non-linear and non-concave due to the dependencies shown in Equation 3.2. As shown in Figure 3.4 is the non-linear and non-concave PQ - curve linearized with segments, where local, best efficiency points and points of maximum discharge are used as breakpoints. The first segment, from  $(0,0)$  to the first breakpoint, gives a slightly poor approximation, but often more is produced than what is defined as the best point for this segment.

The discharge and production for a given node  $n$  in time period  $t$  are now presented as partial sums over the segments, as presented in Equation 3.3 and 3.4:

$$q_{t,n} = \sum_{k \in \mathcal{K}} q_{t,n,k}, \quad \forall t \in T, \forall n \in N \quad (3.3)$$

$$p_{t,n} = \sum_{k \in \mathcal{K}} q_{t,n,k} \cdot \beta_{n,k}, \quad \forall t \in T, \forall n \in N \quad (3.4)$$

The discharge in each time period  $t$  for each node  $n$  in a segment  $k$  is equal to the sum of each partial discharge  $q_{t,n,k}$ , where  $k \in \mathcal{K}$ .

For the production it is now represented by its linear segments given the discharge in each segment. This is developed and simplified from Equation 3.2 after the assumptions made above. The last segment,  $D$ , will not increase the production, but represents spillage and bypass discharge. Since the relationship between production and discharge is convex, the mathematical model will always complete one segment before starting the next. That is, as long as  $p_A$  is not maximized,  $p_B$  will not take any value. Within a segment, the slope,  $\beta$ , is constant. In a transition to the next segment, the need for a higher discharge will increase for a given amount of production, i.e higher specific discharge. This ensures the model to always use up the amount of water for the lower segment before starting on a higher segment.

### 3.3.4 Objective value

There exists different ways to implement the objective value function to solve the short-term hydropower scheduling as a linear program, depending on what the hydropower producer wants to achieve. If the operation after the clearing of the spot market is the focus, then a load obligation for the hydropower producer(s) is included, for each time step. For this case, the water value represents the future value of storing the water in the reservoir after the scheduling period. This water value is then obtained by the coupling between the long-term and short-term model shown in Figure 3.2, and different approaches can be used to set a value for the different periods. Benders cut [29] for interpolation between two end period values or use of dual variable to the reservoir balance as water value [30], are two methods to implement a change in water value in the short-term scheduling. The objective of the optimization model can then be expressed as:

$$\min \sum_{n \in N} k_{t,n} \cdot (v_{1,n} - v_{t,n}), \quad \forall t \in t_{end} \quad (3.5)$$

Where  $k_{t,n}$  is the water value at node  $n$  in time step  $t$  and  $v_{t,n}$  is the reservoir level at node  $n$  in time step  $t$ . Since this is a minimization problem, the objective is to minimize the value of water used to cover the load, and that's why the difference in reservoir level between the first and

last period is valued. This objective function requires that a load is going to be met, otherwise it will be produced 0 MW to minimize the objective function. Another way to implement the same case is to maximize the value of the remaining water in the reservoir.

Another approach is to maximize the profit from selling energy to the market [31]. This is not the same as above, since the hydropower producer will balance and maximize the income now and in the future. This is balanced with the future expected income of the water remaining in the reservoir, and can be written as:

$$\max \sum_{n \in N} p_{t,n}^s \cdot e_{t,n} + \alpha_{t,n}, \quad \forall t \in T \quad (3.6)$$

Where  $p_{t,n}^s$  is the price in period  $t$  for a given node  $n$  and  $e_{t,n}$  is the energy sold to the market in period  $t$  from a given node  $n$ .  $\alpha_{t,n}$  represents the future expected income from having water left in the reservoir at the end of the scheduling period  $t$  for node  $n$ . This future value is important to include in the model to prevent the reservoir from being emptied during the scheduling period, as the objective is to maximize the profit.

Minimization of total operational costs is a used objective function when the value of stored water is ignored [32]. Since start-up and shut-down of a hydropower plant reduces the lifetime of the machine, this optimization model would like to reduce the number of start-ups and shut-downs, as shown in Equation 3.7:

$$\min \sum_{t \in T} \sum_{s \in S} \sum_{i \in I_s} C_{i,s} \cdot \mu_{i,s,t} \quad (3.7)$$

$C_{i,s}$  represents the start-up cost of unit  $i$  in plant  $s$  and  $\mu_{i,s,t}$  is the decision variable, taking the value 1 if unit  $i$  in plant  $s$  is started in period  $t$ . The shut-down costs could also be included in the same way. The start-up costs could be expressed as a function of nominal power output or history of expenses regarding maintenance given the number of start-ups. This is not a commonly used objective function as hydropower producers cannot ignore the value of the water in their reservoirs. The number of start-ups/shut-downs should rather be reduced by including conditions in the restriction for the relation between production and discharge.

The same thoughts presented in the model above are implemented in some models, where the objective is to minimize the power generation losses [33]. To maximize the efficiency of the power plant, it is desirable to express the losses regarding tailrace elevation, penstock and turbine-generator variations, and include this expression in the objective function. By including the start-up and shut-down costs and generation efficiency, the optimization model can be written as:

$$\min \sum_{t \in T} c_{ap} \cdot |\Delta n_t| + c_p \cdot p_n(d_t) \quad (3.8)$$

The first component in the objective function represents the cost,  $c_{ap}$ , for starting up or shutting down a number of generating units in period  $t$ .  $\Delta n_t = n_t - n_{t-1}$ , where  $n_t$  is the number of generating units in operation in hour  $t$ . The second component tells how the costs related to power generation,  $c_p$ , varies with the power loss function for  $n$  units in operation at hour  $t$ ,  $p_n(d_t)$ . The power loss function is dependent on the number of generating units, and is therefore a function of  $d_t$ , which is the generation schedule in period  $t$ . This is then the number of generating units that have to be active due the restrictions, such as load that has to be met.

After the Norwegian power market was deregulated in 1991, the consumers and producers have seen great changes. To reduce price differences, increase efficiency of the producers and get a better balance between supply and demand were the main goals of the deregulation. Deregulated power systems are integrated in some parts of the world (e.g. Scandinavia, great parts of EU and some parts of USA and Canada), where a market clearing process takes place. An intersection between the supply and demand curves decides the market clearing price and the distribution of electricity production. The objective value represented in Equation 3.6, which maximizes the profit from selling energy to the market, is the most appropriate representation of the deregulated market. Minimizing the value of water used to cover the load, as shown in Equation 3.5, is another objective function that represents a deregulated market well for the hydropower producer.

### 3.3.5 Water value estimation

The estimation of the specific value of the water is of great importance to the hydropower producer. As the water can be stored for later use the hydropower producer will try to optimize the usage, making sure the water is utilized in the best possible way given prospected future value. Estimating the water value is an advanced technique. A majority of factors will affect the value of storing water for the future. The water value is affected by, among other things, reservoir filling related to the individual power plant, efficiency per unit, start-stop costs, inflow and price forecasts in the short and long-term [34].

Of the factors mentioned, both inflows and price forecasts are stochastic variables. This entails uncertainty both in the short and long-term for the pricing of the water. Inflow will depend on precipitation, melting of snow and temperatures. The price will again depend on the inflow, in addition to reservoir level, consumption, cost and capacity of other energy sources in the power system such as thermal plants, wind power, solar power and transmission capacities in the grid. This is a very complex composition that requires advanced models to be able to calculate the water value. The water value is calculated in the long-term and seasonal models which deals with uncertainty [35]. Short-term models inherits the value as a boundary condition from the seasonal model in addition to reservoir boundaries as seen in Figure 3.2, dictating the short-term hydropower scheduling decisions.

## 3.4 Optimal power flow

Optimal power flow is an essential part of the operation of electrical power systems. The operation of the power system is a challenging task, where the interactions between the supplier and the customer plays a vital part in how the grid is utilized. To be able meet the load obligation in the most efficient way many techniques have been developed. Due to the complex nature of power flow, simplifications has been made to decrease the comprehensiveness of the computations, while maintaining the attributes of the system. The power flow in a system can be derived using the network topology, parameters needed to build the admittance matrix (susceptance in the transmission lines) and information about the nodes. These calculations are called load flow calculations. This section presents a thorough explanation of the power flow equations and assumptions used in the model developed in the thesis.

### 3.4.1 DC Optimal Power Flow

DC optimal power flow is a well known technique, used to find the optimal solution to the challenging task of meeting the load obligation in the power system. The technique is derived by using assumptions to simplify the AC load flow, to the linear DC load flow, and then combining it with the optimal dispatch problem. The derivation is for a base case with  $M$  generators, and

linear costs such as a constant marginal cost of production. Without taking into account the characteristics of the power system, the optimal dispatch problem can be defined:

$$\text{minimize} \quad f(P) \quad (3.9)$$

$$\text{subject to:} \quad \sum P = D \quad (3.10)$$

$$P_{min} \leq P \leq P_{max} \quad (3.11)$$

This minimization problem aims to minimize the cost of producing the required power. Here  $f$  is the cost function for the generators in the system,  $P$  is the generation,  $D$  is the demand and  $P_{min}$  and  $P_{max}$  the minimum and maximum production of the generators. The first constraint secures that the production in the system meets the demand. The second constraint introduces some aspects that needs to be taken into account when looking at the result, the three different cases are:

- All generators will have the same marginal costs
- A generator will run at max capacity and have marginal cost lower than the system
- A generator will run at min capacity which can be zero, and have a higher marginal cost than the system

From this simple dispatch problem the DC OPF can be obtained by adding the grid constraints into the problem:

$$\text{minimize} \quad f(P) \quad (3.12)$$

$$\text{subject to:} \quad P - D = -jY\Delta \quad (3.13)$$

$$FL_{min} \leq F\Delta \leq FL_{max} \quad (3.14)$$

$$P_{min} \leq P \leq P_{max} \quad (3.15)$$

Constraint (3.13) says that the difference in production and demand in a node is equal to the transfer to or from the node, and the flow lies between the min and max capacity of the line in question (from Constraint (3.14)). Usually  $FL_{min} = -FL_{max}$ . In the problem  $\Delta$  is the vector containing the voltage angle at the nodes. The F matrix is known as the connection matrix which defines the network topology, where the elements are equal to  $|b_{ij}|$  if  $i$  is the from node, and  $-|b_{ij}|$  if  $j$  is the to node of the line. Y is the admittance matrix of the system, and  $j$  denotes the imaginary number of the entries in the admittance matrix.

### 3.4.2 Multi-period DC OPF

To do an analysis over a period of time it is necessary to extend the DC OPF methodology to account for the time steps in the analysis. The DC OPF problem derived above concern the state of operation at a specific time. To study the dynamics over a period of time the restriction for the storage system in the problem can be used to link the periods together, in this case the reservoir balance is the connection between each time step. The state of the storage system at the start of each period will thus inherit the end-state from the previous time step, coupling each of the time steps together. By doing so, the snapshot of the optimal power flow in the system becomes a series of snapshots, transforming the standard DC OPF-problem into a multi-period problem expanding the analysis horizon. Due to the time-dependencies in the reservoir level, the model needs to make sure the level is within the boundaries in every time step. The coupling

adds to the complexity of the optimization model as the decisions made in one time step directly affect the decisions to be made in other time steps. Thus, the problem can be interpreted as a number of simultaneously solved coupled OPFs.

A multi-period DC OPF problem will contain the same variables as a single-period problem but due to the period of the problem these variables will be assigned different values for each time step. Therefore, a system with  $n$  generators would in this case end up with  $T \cdot n$  generators, assuming the number of time steps are  $T$ . The same applies to all the variables in the model.

### 3.4.3 AC load flow

AC load flow is the most comprehensive way of describing how the power system behaves. Taking into account the non-linearity and the advanced aspects of the system, it gives a thorough representation of the dynamics that makes up the load flow. From the derivation of AC load flow the equation for active power is given as [36]:

$$P_i = \sum_{n=1}^N |V_i V_n Y_{in}| \cos(\theta_{in} + \delta_n - \delta_i) \quad (3.16)$$

In Equation 3.16  $V_i$  represents the voltage at the sending node,  $V_n$  is the voltage magnitude at the receiving node,  $\delta_i$  is voltage angle at sending node and  $\delta_n$  is voltage angle at receiving node,  $Y_{in}$  stands for the entries in the admittance matrix and  $\theta_{in}$  is the angle of the entries of the admittance matrix.

### 3.4.4 DC load flow

In general, load flow computations can be comprehensive and often multiple iterations are required, thus a linear approximation of the load flow is often used: this is called DC load flow. One of the advantages of using this technique is that it's easy to combine with linear optimization problems such as optimal dispatch. In DC load flow assumptions are made so the non-linear load flow equations become linear to reduce the computational time and to make the calculations easier. The following assumptions are made in DC load flow [37]:

- all node voltages is equal to 1 pu
- resistances of the transmission lines are neglected meaning  $G_{ij} = 0$  such that  $Y_{ij} = jB_{ij} = |Y_{ij}| \theta_{ij}$  with  $\theta = \frac{\pi}{2}$  rad,  $G$  and  $B$  are respectively the real and the imaginary part of the admittance
- the difference in voltage angles at the nodes are very small such that:  $\sin(\theta_j - \theta_i) \approx (\theta_j - \theta_i)$  and  $\cos(\theta_j - \theta_i) \approx 1$

By applying these assumptions to Equation 3.16, the power flow equation for active power can be written as:

$$\begin{aligned} P_i &= \sum_{n=1}^N |V_i V_n Y_{in}| \cos(\theta_{in} + \delta_n - \delta_i) \\ &\approx \sum_{n=1}^N |Y_{in}| \cos\left(\frac{\pi}{2} + \delta_n - \delta_i\right) = \sum_{n=1}^N |Y_{in}| \sin(-\delta_n + \delta_i) \\ &\approx \sum_{n=1}^N |B_{in}| (\delta_i - \delta_n) \end{aligned} \quad (3.17)$$

The resulting equation gives the linear relationship between the active power injected at a node, and the voltage for the given node. Where  $B_{in}$  is the susceptance matrix. Further the expression for power flow in the lines is expressed as:

$$P_{ij} = -b_{ij}(\delta_i - \delta_j) = \frac{1}{x_{ij}}(\delta_i - \delta_j) \quad (3.18)$$

In Equation 3.18,  $\delta_j$  is the voltage angle at the receiving node, and the assumption that  $R = 0$  is made.

### 3.4.5 Effect of assumptions on solution

The assumptions and simplifications in the model are made to present a straightforward system, which maintain the vital information needed to assess implications of introducing power flow equations into the STHS. In a real system, power losses, voltage fluctuations etc. need to be addressed. These issues are not the focus in this thesis, as only the larger power flows are considered, meaning the minor details will not be of great interest or influence.

These assumptions makes up an efficient way of calculating the power flows in a system, at the same time some information is lost along the way. In reality the voltages will in most cases not be flat, but will vary across the different buses in the system. This means that the assumed X/R-ratio could be difficult to guarantee, as the influence of the resistance increases with the decrease of voltage, meaning only high-voltage systems can tolerate these conditions. The deviation from the predefined voltage and the the X/R ratio will influence the active power estimation error. Increase in voltage deviations and higher resistance, implicates higher  $P_{error}$  [38]. The assumptions will influence the solution, leading to a less accurate solution to the power flow equation compared to AC load flow [39].

This report focus on the power flows in the transmission system, the effect of the simplifications will not be substantial. In general active power losses in the transmission system are low, meaning the influence on the optimal solution may be ignored for the purpose of this analysis. Voltage drop across lines are also considerably low in the transmission system, justifying the assumption of equal voltages at the nodes. Thus the accuracy of applying the extended DC OPF model in this report, is sufficient to analyse the objective.

## 3.5 Different solutions to the problem

### 3.5.1 Available transmission capacity (ATC)

In the Norwegian power market, Available Transmission Capacity (ATC) is used to clear the day-ahead market coupling. The method deals only with commercial flows between the different bidding zones, as the management of the real physical flows is left to the TSO [40]. Congestion in the system is solved by regulating the net positions on both sides of the congested transmission line. Therefore the TSO has to manage the bottlenecks and prioritize where it should allocate the capacity. The calculations behind this method requires prediction which can be complex especially in a meshed grid.

### 3.5.2 Flow-based market coupling (FBMC)

Another method dealing with the issues encountered between the bidding zones is called Flow Based Market Coupling (FBMC). The method is similar to ATC but differs on how the power flow in the system is accounted for. FBMC allows for more accurate representation of the attributes as it account for how power divide itself along the path from one node to another in the system, given by the impedances present in the lines. Thus, power transfer distribution

factors can be calculated based on this that show the amount of power from a specific node appearing in the lines. As a result of including the power flow with more realistic features, the method removes the TSOs responsibility to handle the physical flows, this will be done by the market algorithm itself. In addition, including a more realistic representation of the power flow in the system will expand the possible solutions to the problem. This is highlighted in Figure 3.5i below, which shows the domain for both methods in the three node system in Figure 3.5ii.

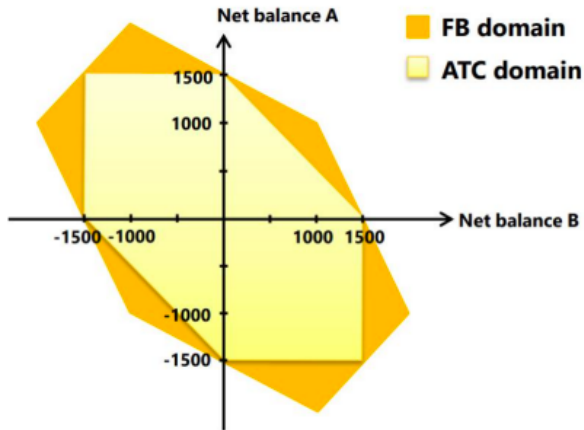

(i) The domain for ATC and FBMC. Adapted from [40]

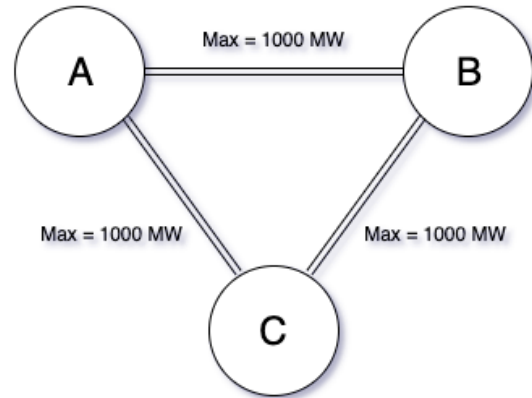

(ii) Three-node system

Figure 3.5: Comparison between ATC and FBMC



## 4 Model and methodology

The optimization model utilized in this thesis is developed and constructed by the authors. The goal of building the model is to extend the STHS to account for the actual possibilities the nearby grid offers. This implies that the producers will not only be limited by their own technical aspects, but also the limitations from the power grid such as capacity limits on transmission flow.

### 4.1 Model presentation

This section presents the mathematical formulation of the optimization model developed in this thesis. The case study in this report is conducted by using a linearized multi-period DC optimal power flow algorithm combined with short-term hydro scheduling. All sets, variables and parameters are presented in the *nomenclature*, giving an overview of the different aspects influencing the algorithm.

The mathematical formulation for the optimization problem can then be formulated as:

$$\underset{v,k}{\text{minimize}} \quad \sum_{n \in \mathcal{N}} k_{t,n} \cdot (v_{1,n} - v_{t,n}), \quad \forall t \in t_{end} \quad (4.1)$$

$$\text{subject to} \quad q_{t,n,k} \leq Q_{n,k}^{max}, \quad \forall t \in \mathcal{T}, \forall n \in \mathcal{N}, \forall k \in \mathcal{K} \quad (4.2)$$

$$\sum_{k \in \mathcal{K}} q_{t,n,k} - q_{t,n} = 0 \quad \forall t \in \mathcal{T}, \forall n \in \mathcal{N} \quad (4.3)$$

$$v_{t,n} \leq V_{t,n}^{max}, \quad \forall t \in \mathcal{T}, \forall n \in \mathcal{N} \quad (4.4)$$

$$v_{t,n} \geq V_{t,n}^{min}, \quad \forall t \in \mathcal{T}, \forall n \in \mathcal{N} \quad (4.5)$$

$$v_{t,n} - v_{t-1,n} + f(q_{t,n} + s_{t,n} - I_{t,n}) = 0, \quad \forall t \in \mathcal{T}, \forall n \in \mathcal{N} \quad (4.6)$$

$$\sum_{k \in \mathcal{K}} q_{t,n,k} \cdot e_{n,k} - p_{t,n}^G = 0, \quad \forall t \in \mathcal{T}, \forall n \in \mathcal{N} \quad (4.7)$$

$$\sum_{i \in \mathcal{N}} p_{t,i}^G - \sum_{i \in \mathcal{N}} p_{t,i}^D = 0, \quad \forall t \in \mathcal{T} \quad (4.8)$$

$$p_{t,ij} \leq P_{t,ij}^{max}, \quad \forall t \in \mathcal{T}, \forall i, j \in \mathcal{N} \setminus \{i = j\} \quad (4.9)$$

$$p_{t,i}^G - p_{t,i}^D = \sum_{j \neq i} p_{t,ij}, \quad \forall t \in \mathcal{T}, \forall i \in \mathcal{N} \quad (4.10)$$

$$p_{t,ij} = \frac{1}{x_{ij}} (\delta_i - \delta_j), \quad \forall t \in \mathcal{T}, \forall i, j \in \mathcal{N} \setminus \{i = j\} \quad (4.11)$$

#### 4.1.1 Objective function

The objective function highlight the overall goal in the optimization algorithm, which is to minimize the value of the water used to cover the load obligation in the system. This is similar to maximizing the value of the water in the reservoir(s). The summation secures that the value

of the water used to cover the demand for all reservoirs is accounted for. This is often referred to as the water value function, as the future value of the water in the reservoir(s) at the end of the planning period is accounted for.

From the literature review executed in Section 2, we can observe from Table 2.1 that there are different objectives for the different research papers. The majority of the objectives in the studied articles want to *maximize social welfare/surplus*, as they seek to find an equilibrium price for a good or service, where producer and consumer surplus are maximized. As we are looking from the hydropower producers perspective, we want to minimize the value of water used to cover the load. Here it is a predefined load obligation to cover, while the other articles search to find equilibrium by including aggregated supply and demand curves.

#### 4.1.2 Restrictions

##### Hydro constraints

The hydro restrictions ensure that the operation of the hydropower plants are within operating limits. Restriction (4.2) keeps the discharge through the turbines below the upper limit for all PQ-segments. Restriction (4.3) ensure that the total discharge for all plants are equal to the sum of the discharge for all PQ-segments in every time step. Together with Restriction (4.7), these restrictions ensure that the relation between the power output  $P$  and the discharge  $Q$  remains linear maintaining a convex problem. Further Restriction (4.4) and (4.5) ensure that the reservoir(s) balance is within the lower and upper bound. (4.6) secures the reservoir balance in the system, where the balance in time step  $t$  is equal the end reservoir level of time step  $t-1$  in addition to any inflow in time step  $t$ , subtracted the discharge in time step  $t$ . If the reservoir level hit the lower bound the power plant connected to the reservoir in question would not be able to produce. In the latter case the reservoir would experience spillage, resulting in the water value dropping to zero. Restriction (4.7) gives the power output for the given discharge through the turbine, accounting for the efficiency for each of the PQ-segments.

##### Power flow constraints

Restriction (4.8) ensure that the load obligation is covered by the producers for each of the time steps. To secure that the transmission lines are not overloaded Restriction (4.9) is implemented, keeping the line flow below the thermal capacity. The restriction on capacity is one of the main differences compared to how STHS is conducted today as the hydropower producers have an additional restriction to account for. Further the balance in both nodes and transmission lines are secured by Restriction (4.10) and (4.11) respectively. From Restriction (4.10) the power flow to or from a node is decided by the difference between the produced power and demand at the node. Restriction (4.11) is the expression for power flow in the DC approximation, where the susceptance in the lines together with the difference in node voltage phase angle for the connected nodes generates the line flow. Together with Restriction (4.9) they represent the technical part of power flow in the optimization model.

## 4.2 Method

The parameters used in the model consist of realistic data, such as line data and PQ-curves obtained from NVE and SINTEF Energy respectively. In addition some vital data has been constructed by various methods. These methods are thoroughly explained below. The first week in January 2021 was decided as the period for the analysis, thus the data obtained and constructed reflect the situation during that week.

### 4.2.1 Topology

The transmission grid seen in Figure 4.1 was constructed on the basis of the hydropower plants given access to through SINTEF Energy. It was desirable to keep the analysis on a transmission grid level to lessen the burden of obtaining the characteristics and building a system to conduct the analysis presented in this thesis. As previously mentioned, data on 19 regulated hydropower plants were provided and the location of these plants highly influenced the decision on where nodes in the network should be located. In some cases the plants were located in the lower layers of the grid such as the regional or the distribution grid. For these cases it was assumed that the capacity of the nearby grid was sufficient, meaning the plants in the underlying distribution grid could feed directly into the transmission grid without experiencing challenges regarding bottlenecks. Also, some of the plants were located in close proximity and it was considered reasonable to create aggregated nodes where the plants in question all could feed power into the system. In addition, nodes were included in the grid on the basis of where larger loads such as cities and industry were located in the region. A map over the grid in NO4 and the connecting price zones is available at NVE [41], and were used to construct the grid presented in Figure 4.1. Furthermore, grid data necessary to run the DC OPF-part of the optimization model such as resistance of the modelled lines was provided by NVE. The transmission capacity was not available thus the capacities had to be constructed to mimic realistic situations in the operation of the power grid.

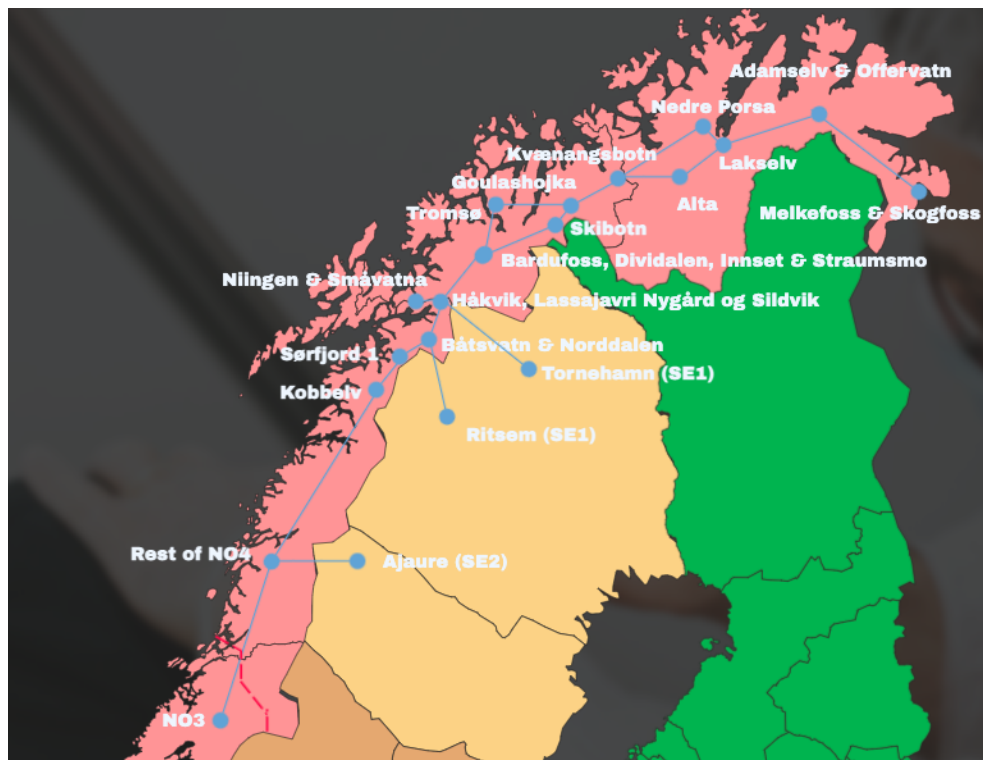

Figure 4.1: Nodal representation of parts of the Nordic system

### 4.2.2 Hydropower plants

The model and methodology are based on data from 24 hydropower plants in the northern part of NO4. These power plants range from Kobbelv, which is the southernmost power plant in the system, to Melkefoss, which borders Russia in the northernmost part of the country. 19 of these power plants are located on regulated reservoirs, so they act as energy storage sites in the Norwegian electricity system, as production can be regulated according to demand. The

remaining 5 hydropower plants are run-of-river power plants, which means that they produce power continuously with the inflow of water. The 4 run-of-river power plants are modeled as negative loads on their associated nodes. Then the data regarding inflow to the reservoir and PQ-curves for the power plant are utilized to provide information regarding the continuous power production at the run-of-river power plants, and you can further remove a share of the load on the relevant node in the system.

### 4.2.3 Nodes

The nodes in the system are represented by the 24 hydropower plants, in addition to load nodes created to generate power flow to locations with high demand. How the demand is determined for the system is presented in Section 5.6. Table 4.1 displays the content at the various nodes:

Table 4.1: Numbering and content at the different nodes

Name	Node number	Comment
Melkefoss & Skogfoss	1	Load
Adamselv & Offervatn	2	Generation and load
Lakselv	3	Only connection node
Alta	4	Generation and load
Nedre Porsa	5	Generation and load
Kvænangsbotn	6	Generation
Guolasjohka	7	Generation
Skibotn	8	Generation
Tromsø	9	Load
Bardufoss, Dividalen, Innset & Straumsmo	10	Generation
Håkvik, Nygård, Sildvik & Lassajavri	11	Generation and load
Niingen & Småvatna	12	Generation and load
Tornehamn (SE1)	13	Load
Båtsvatn & Norddalen	14	Generation and load
Ritsem (SE1)	15	Load
Sørfjord 1	16	Generation
Kobbelv	17	Generation
Rest of NO4	18	Load
Ajaure (SE2)	19	Load
NO3	20	Load

### 4.2.4 Case study

The case study in this thesis is the northernmost price zone in the Norwegian power system, NO4. NO4 has been a region of interest and discussions due to the large surplus of power in the region compared to the capacity of the overlaying transmission grid. As seen in Figure 4.1 NO4

is an extensive zone which to a large degree contains a radial transmission grid. As a result of the surplus and radial grid the spot market price in the region more than often differs from the neighboring price zones, typically lower. NO4 is known to be a surplus area regarding power production. Within NO4 several large hydropower plants are located and they are capable of delivering more power to the rest of the power system should the transmission capacity allow it.

The modelled price zone will provide analytical results allowing for a better understanding on how an extensive grid consisting of loads and hydropower plants will behave. The relevant parameters for the system are presented in Chapter 4 and the optimization cases analyzed are presented in Section 4.2.5. The analysis is conducted for a period of one week where each hour represents a time step, similar to the day-ahead market. Thus, it will be of great interest to see how the production planning will be conducted given the variations in water value together with grid limitations in the system.

#### 4.2.5 Optimization cases

The case study consists of three optimization cases. Each case is designed with inspiration from real challenges encountered in the day to day operation of the Norwegian transmission system, starting from the base case which is similar to how STHS is conducted today and thus will provide a great starting point for comparison. The simulations are done over a time span of 168 time steps representing the first week in January hour by hour.

In general, DC OPF concern a snapshot of the optimal power flow in the system. It is necessary to connect the periods giving the optimization model the ability to plan throughout the time span. Therefore, this model uses the reservoir balance equation (4.6) as the connection between the time steps making the optimization model a multi-period DC OPF.

The load characteristics are extracted from Nord Pool's data base and consider the load for NO4 in 2021. All simulation cases consider the same load data. This case study aims to highlight how the power producers decision making changes to deal with typical situations experienced in the Norwegian power system, which will further contribute to the discussion presented in Chapter 7.

##### Base case

The base case is constructed to imitate how STHS is conducted today meaning the hydropower producers neglect the grid topology and restrictions when production planning is conducted. The simulation is run for the whole time span with this topology. The results from the simulation will serve as a reference point for the influence network characteristics and topology induce into the production planning.

##### Case 1 - Ofoten bottleneck

Within NO4 there are certain passages that restricts the possibility to transport power from the northern part further south as the capacity of the transmission lines are not sufficient. Ofoten is one of the passages that has been widely discussed. In 2017, a new 420 kV transmission line was completed on the distance Ofoten-Balsfjord with the goal of erasing the bottleneck as well as increasing the power supply security [42]. Although the new transmission line dealt with some of the issues regarding capacity and security the region still experiences challenges with surplus of power with little possibilities of transportation out of the area [6]. Thus, this case introduces a capacity restriction on the line close to Ofoten shown in Figure 4.2 below. This is done by introducing a 40 MW capacity limit on the line between node Håkvik and Båtsvatn in the system presented in Figure 4.1. The reason the capacity is set at 40 MW is the scaling of the data previously explained, as the capacity has to be that low to see the effect of the limitations.

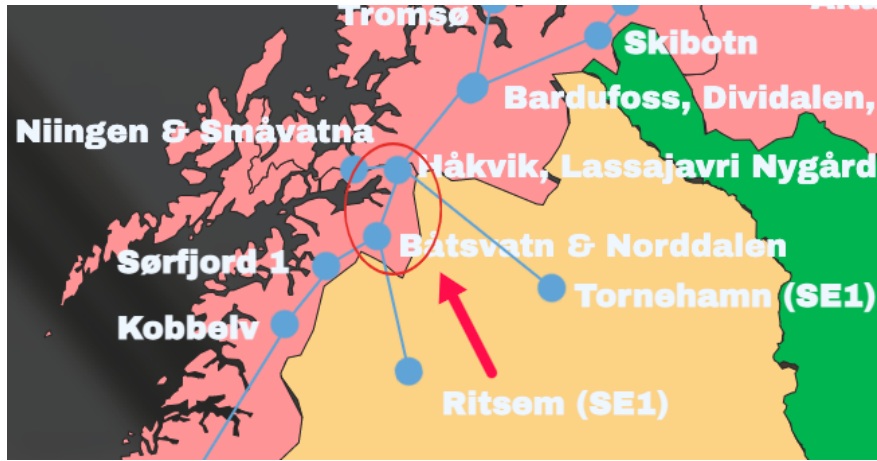

Figure 4.2: Visualization of the restricted line in Case 1

### Case 2 - East to west bottleneck in Finnmark

The second case introduces a restriction in the northernmost part of NO4. The transmission system in Finnmark is a part of the Norwegian transmission system with low capacity. The lines in Finnmark are built in such a manner that they reach the maximum flow at approximately the same time, which is one of the main reasons Statnett consider it to not be beneficial to increase the capacity in the region [43]. This is also the reason for why 175 MW in wind production (Raggovidda and Hamnefjell) with concession given has not been developed. Bottlenecks are often experienced between the eastern and western part of Finnmark. Therefore a restriction on power flow has been introduced on the lines highlighted in Figure 4.3. This is done by introducing capacity limits on the line Nedre Porsa-Kvænangsbotn and Alta-Kvænangsbotn at 10 MW and 40 MW respectively. The reason the capacity is set at 10 MW and 40 MW is the scaling of the data previously explained, as the capacity has to be that low to see the effect of the limitations.



Figure 4.3: Visualization of the restricted line in Case 2

The optimization cases are summarized in Table 4.2:

Table 4.2: Composition of the different cases

Case nr.	Description	Purpose
Base case	Imitation of standard STHS	Laying the foundation for comparison
Case 1	40 MW capacity between Haakvik and Båtsvatn	Imitation of the Ofoten-bottleneck
Case 2	10 MW and 40 MW capacity between Nedre Porsa-Kvænangsbotn and Alta-Kvænangsbotn respectively	Imitation of the scarce transmission capacity between east and west in Finnmark

#### 4.2.6 Software

For the purpose of this thesis the simulations were carried out by an optimization tool called Pyomo. Pyomo is a Python-based open-source software package that supports a diverse set of optimization capabilities for formulating, solving, and analyzing optimization models [44]. Supporting numerous of solvers Pyomo offers many possibilities, in this thesis a solver called GLPK is utilized. GLPK was created to solve large-scale linear programming and also provide the dual values of the problem, making it a desirable solver in the analysis conducted [45]. One of the advantages with Pyomo is how well documented it is, in addition it is made to easily replicate mathematical optimization problem in code, therefore making the implementation of custom mathematical model easy. For these reasons Pyomo was chosen to conduct the optimization necessary in the thesis.

## 5 Data construction

This chapter presents the extensive and detailed work related to the development of the data for the optimization model, to make realistic analyzes. Production-discharge curves for the hydropower plants are provided by SINTEF, but had to be altered. Different methods were used to construct water values, inflow, start reservoir levels and demand for the system, while line data for the power grid in Northern Norway was provided by NVE.

### 5.1 PQ-curves

The PQ-curves presented in Section 3.3.3 is a vital part of the model developed, as they describe the relationship between the amount of water used to produce a given amount of power, at the hydropower plants. For this thesis, SINTEF Energy provided linearized data of the PQ-curves for a selected number of hydropower plants in the northern part of NO4, derived in SHOP, as given in [32]. The provided data allowed for operating points with negative production at the power plants, as showed with the blue line in Figure 5.1. This could have been dealt with in different ways. One of which is by introducing binary variables, activating the linearized segments when the production was above zero. The second option was to alter the segments so that negative production would not occur. The first option would introduce non-linearities into the model. This would cause that information of interest, such as dual values, used to obtain nodal prices, would not be available from the model. Therefore, the second option was chosen, as it kept the model linear. To fit the data into a linearized problem, four of the first segments were aggregated to force the production to become zero when the discharge through the turbines were zero. The number of segments to be aggregated were chosen to be four, as altering fewer segments would introduce higher marginal increase on the latter segments, leading to an incorrect discharge. A visualization of the manipulation can be seen in Figure 5.1. In the figure, the red dotted line is the new aggregated segment used in the model, the figure is purely a visualization with fictive values.

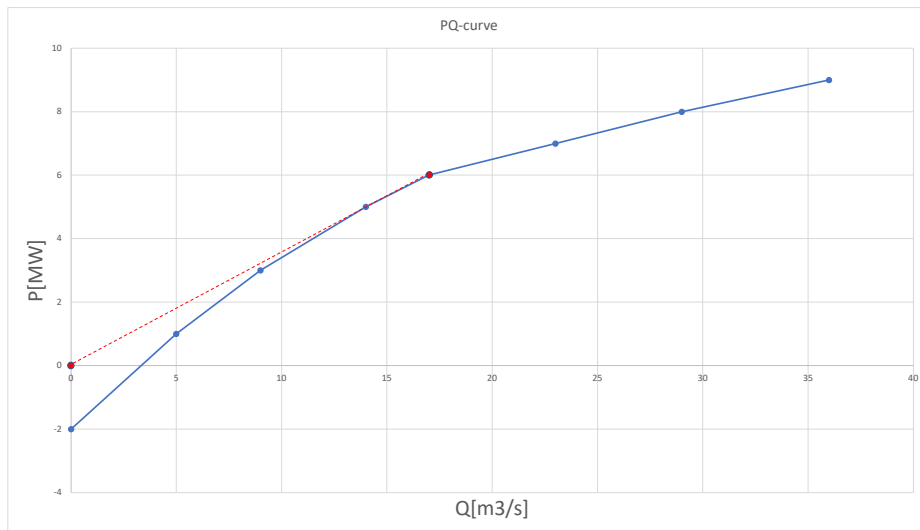

Figure 5.1: Aggregated PQ-curve used in the model

By using this method to alter the curves, the model was kept linear. At the same time, the limit on water used on the aggregated segment was set to be between zero and the best operating point on the last aggregated segment. Therefore, the water usage did not differentiate substantially compared to a case where the original curve had been used. The reasoning behind this can be explained by the fact that if the producer is willing to produce at the minimum capacity, it



would benefit from increasing the production until the plant is operating at the best operating point, as it would obtain higher efficiency. Thus, altering the PQ-curve below the best operating point has little impact on the solution.

Regarding the PQ-curves, which addresses the relation between production and discharge for a hydropower plant, they are provided by SINTEF Energy. They designed a scheduling tool for hydropower called SHOP (Short-term Hydropower Optimization Program), where they use the same structure on the PQ-curves as we do. SHOP is formulated as a MILP (Mixed Integer Linear Programming) model, and they have to obtain linear and concave PQ-curves to run their model, as in our case. The only simplification performed was to alter the segments to avoid negative production. Binary variables could have been introduced, but this would cause the problem to become non-linear. Thus, the PQ-curves were altered below the best operating point, which would not affect the solution to a great extent. If the hydropower producer decides to produce, it is not very favorable to produce under best point, and it justifies the simplifications.

## 5.2 Inflow

Inflow to a reservoir, as mentioned in Section 3.3, is important to be representative for each reservoir, for the model to give a realistic picture of the inflow pattern of reality. The model presented in Section 4.1 is a short-time optimization model reflecting the day-ahead market, where hourly clearing prices are a result of supply and demand. As the time step of the short-time optimization model applies to each hour within 1-2 weeks, this entails that the model needs inflow data for each individual hour within the entire analysis period. This kind of data is not possible to obtain and had to be constructed in a most realistic way.

The data was constructed in the following way:

1. The Norwegian Water Resources and Energy Directorate (NVE) has an overview of all developed power system, hydropower, watercourse, wind power etc. in Norway. There you find the annual average inflow to the reservoir of interest by selecting the desired precipitation field  $\left[\frac{Mm^3}{year}\right]$ . This average inflow to the reservoir is used for scaling.
2. After the first step, you have to find real time data on water flow of an unregulated hydropower station nearest the regulated power plant of interest. Given the topology, this method gives the best possible real-time data on inflow to the reservoir. These data series are available at the database Sildre at NVE [46].
3. Finally, the series are scaled so that they provide actual information regarding inflow to the reservoir. The data series provided in step 2 was given in  $\left[\frac{m^3}{s}\right]$ , and had to be converted to  $\left[\frac{Mm^3}{year}\right]$  for a calendar year. The scaling factor is now calculated by finding the ratio between the annual average inflow for the actual reservoir in step 1, and the calculated annual inflow for the unregulated power station nearest the actual reservoir. The inflow in the desired period can now be calculated by multiplying the scaling factor with the series converted to  $\left[\frac{Mm^3}{year}\right]$  for a calendar year.

The following is an example on how this method was conducted on the hydropower unit Innset, with the precipitation field Altevatn:

- The annual average inflow to the precipitation field Altevatn was  $Q_{normal} = 1063.08 \frac{Mm^3}{year}$ .
- Further, the unregulated hydropower station closest to Altevatn was identified in Sildre. Lundberg was the closest unregulated hydropower station to Altevatn.
- The inflow to Lundberg was downloaded from Sildre and scaled such that only whole calendar years were shown.

- Then the annual inflow were calculated by converting the downloaded values in  $\left[\frac{m^3}{s}\right]$  to  $\left[\frac{Mm^3}{year}\right]$ . This gave an annual inflow of  $Q_{scale} = 411.44 \frac{Mm^3}{year}$ .
- This resulted in a scaling factor for Altevavn to:  $\alpha_{scale} = \frac{1063.08}{411.44} = 2.584$ .
- Inflow of the desired period (the first week of January 2021) were calculated by taking the downloaded data series from Sildre at this period, and multiplied with  $\alpha_{scale}$ .

The method above was conducted at all of the 19 regulated hydropower plants in the system. It was also important to double check that this method actually resulted in the reservoir with the highest  $Q_{normal}$  was getting the highest inflow in the model. As some of the unregulated hydropower stations were located too far away from the respective reservoirs, they could give a misleading indication of the inflow to the reservoirs, and had to be corrected manually.

Inflow in a STHS model is not so important as the inflow at each time step is so small compared to the amount of water in the reservoir, and will not make up the big differences in terms of production patterns in the model. Inflow will affect the model more in cases where the amount of water in the reservoirs approaches the extreme points, as the extreme points can cause the water values to drop towards 0 (risk of spillage, have to produce) or become very large (risk of drought, have no opportunity to produce). High inflow during periods of low reservoir levels or low inflow during periods of high reservoir levels can lead to avoid these situations close to the extreme points.

Apart from this, it was important to ensure that the reservoirs with the highest annual inflow also had the highest inflow during our analysis period. This could mean that some of the data series, which was produced through the method used to create inflow data, based on unregulated hydropower in the proximity of the relevant hydropower plant, had to be scaled up or down. As described above, the inflow will not affect the model significantly in this short analysis period, and it will be more relevant when increasing the time horizon up to two weeks. Real-time data on inflow would clearly be beneficial to get the right attributes in the system at all times. By extending the analysis period to two weeks, and at the same time as hydropower plants with a low reservoir level were analyzed, correct inflow data would have been necessary. Then the inflow data could have affected the water values more, and thus the production pattern and planning had been even more affected in a longer analysis period.

### 5.3 Water values

Water values are the most important aspect of hydropower scheduling, and this is how hydropower producers value the water in their reservoirs, which decides when and how much they choose to produce (their market forecast). Water values must be included in the short-term hydropower scheduling, as this secures the model to take the right decisions. The hydropower producers would not produce if the water value in their reservoir is higher than the market price, but they would choose to produce if the market price is higher than the water value. The expected future value of saving the water to periods with higher market prices could increase their profit, and as the hydropower producers goal is to maximize profits/minimize value of water used to cover the load, the valuation of water in the reservoirs is so important. The connection between the market price and water value is strong, and they influence each other. High inflow and reservoir filling in late spring, summer and early autumn give low market prices, but the hydropower producers want to hold on to the water, as they can expect higher future market prices.

As the water values for the reservoirs connected to the hydropower plants in the model are impossible to obtain (the water value for each producer is secret as it reveals their price view), and the computation from the long-term hydropower scheduling is demanding and not the goal

of this thesis, the Capacity Factor Method is used to determine the water values for the different reservoirs.

This method is based on the operating time of a hydropower plant, which then states how much the plant has to operate to get the inflow through. The capacity factor for a renewable energy source is dependent on the availability of the energy source, because they can be capable to produce, but the driving forces of the energy sources, like wind, sun and water, are unavailable. For hydropower plants, this is more complicated, due to restrictions on water flow and reservoir level, as well as the producers could choose to save the water for periods with higher expected profit.

After the capacity factor of each hydropower plant is obtained, then the historical market prices for NO4 are sorted in a duration curve, from highest to lowest price. As the analysis period is the first week of January 2021, then the market prices of NO4, before the spring flood of 2021, are sorted in this duration curve. The spring flood is a good reference point, as the prices drops distinctly due to increased inflow from the melting of the snow. We would therefore look at the prices before the spring flood to represent the water values in January most accurately. The sorted prices in the duration curve and the capacity factor can thus be used to determine the water value for each reservoir. A hydropower plant with an operating time of 40 % can find the water value on the 60-percentile of the duration curve, while a hydropower plant with an operating time of 80 % can find the water value on the 20-percentile of the duration curve. In other words, a higher operating time gives a lower water value. Hydropower producers will, as mentioned earlier, produce if the market price is higher than the water value. This means that the hydropower plants with a low operating time more frequently experience situations with a higher value of saving the water for later use, and thus higher water value.

An example with Håkvik and Innset are shown in Figure 5.2. The highest market price in NO4 before the spring flood in 2021 was 199.94 €/MWh. Håkvik had a running time of 39.38 % (3450h), and the intersection with the duration curve gave a water value of 31.5 €/MWh. Innset had a running time of 63.47 % (5560h), and the intersection with the duration curve gave a water value of 24.9 €/MWh. Remaining water values are calculated using the same method and shown in Table 5.1.

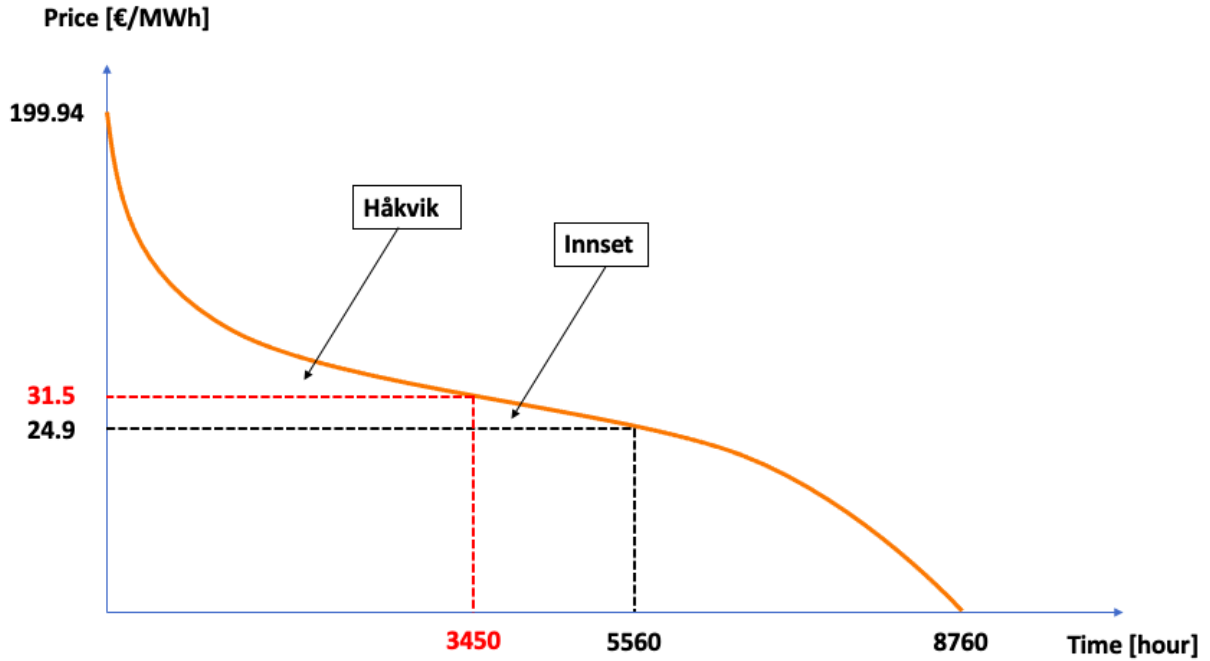

Figure 5.2: Capacity factor method of computing water values

All water values are computed for the different hydropower plants, as shown in Table 5.1. The market price in NO4 are usually stated in €/MWh, but the water values are converted to  $NOK/Mm^3$  with respect to the objective function for the model, presented in Section 4.1. As the reservoir levels are given in  $Mm^3$ , it is more appropriate to have the water values in  $NOK/Mm^3$ , to get the objective value in  $NOK$ . The objective of the model is to minimize the value of water used to cover the load, and therefore is the use of water value in  $NOK/Mm^3$ , multiplied by the change of reservoir level in  $Mm^3$ , a better solution. This also avoids several conversion factors in the objective function.

The conversion from  $€/MWh \rightarrow NOK/Mm^3$  is:

$$\frac{NOK}{Mm^3} = \frac{€}{MWh} \cdot \frac{NOK}{€} \cdot \frac{Wh}{m^3} \quad (5.1)$$

The last term in Equation 5.1 is also referred to as the energy equivalent for the hydropower plant. The energy equivalent tells how much energy a plant can get out per  $m^3$  of water through the turbine [47]. The energy equivalent for each hydropower plant is depending on two factors: efficiency and net head. The overall efficiency of the turbine, generator and transformer at medium loads. The overall efficiency is set to 0.9 for every hydropower plant. Net head is gross fall height minus losses during the fall, from intake to drain. The energy equivalent for each hydropower plant is calculated as:

$$e = \rho \cdot g \cdot \frac{H_n}{3600} \cdot \eta \quad (5.2)$$

where:

- $\rho$ : Relative density of water =  $1000 \frac{kg}{m^3}$
- $g$ : Acceleration of gravity =  $9.81 \frac{m}{s^2}$
- $H_n$ : Net head [m]

- $\eta$ : Overall efficiency of turbine, generator and transformer = 0.9

This further gives that:

$$e = \frac{1000 \cdot 9.81 \cdot 0.9}{3600} \cdot H_n \quad (5.3)$$

$$e = 2.4525 \cdot H_n \left[ \frac{Wh}{m^3} \right] \quad (5.4)$$

Net head varies from 91m at Norddalen, to 719.1m at Guolasjohka, and this leads to the large variations in water values in  $NOK/Mm^3$ . An average Euro exchange rate of 1 €  $\rightarrow$  10.1625  $NOK$  for 2021 was also used for the conversion [48]. An example of the conversion is shown with Guolasjohka, by using Equation 5.1:

$$WV = 28.10 \cdot 10.1625 \cdot 2.4525 \cdot 719.10 \approx 503622.57 \text{ } NOK/Mm^3$$

Remaining water values are shown in Table 5.1:

Table 5.1: Water values for the different hydropower plants

Plant name	Running time	WV [€/MWh]	WV [NOK/Mm3]
Adamselv ( <b>ADA</b> )	4 300.00 (49.09 %)	28.00	139 571.78
Alta ( <b>ALT</b> )	5 082.00 (58.01 %)	26.00	119 882.19
Nedre Porsa ( <b>NED</b> )	4 562.50 (52.08 %)	27.50	147 360.38
Kvænangsbotn ( <b>KVÆ</b> )	3 598.18 (41.08 %)	30.40	233 364.01
Guolasjohka ( <b>GUO</b> )	4 250.00 (48.52 %)	28.10	503 622.57
Skibotn ( <b>SKI</b> )	4 864.29 (55.53 %)	26.50	290 608.37
Dividalen ( <b>DIV</b> )	4 792.31 (54.71 %)	26.60	184 636.01
Innset ( <b>INN</b> )	5 560.00 (63.47 %)	24.90	114 810.25
Straumsmo ( <b>STR</b> )	5 418.46 (61.85 %)	25.00	142 687.22
Håkvik ( <b>HÅK</b> )	3 450.00 (39.38 %)	31.50	170 050.76
Nygård ( <b>NYG</b> )	4 048.00 (46.21 %)	29.00	183 514.45
Sildvik ( <b>SIL</b> )	3 792.31 (43.29 %)	29.70	488 551.06
Lassajavri ( <b>LAS</b> )	4 347.22 (49.63 %)	27.95	101 705.45
Niingen ( <b>NII</b> )	4 094.12 (46.74 %)	28.90	361 369.52
Småvatna ( <b>SMÅ</b> )	3 941.49 (44.99 %)	29.30	161 387.34
Båtsvatn ( <b>BÅT</b> )	3 496.67 (39.92 %)	31.30	159 765.82
Norrdalen ( <b>NOR</b> )	5 320.00 (60.73 %)	25.30	57 381.45
Sørfjord 1 ( <b>SØR</b> )	4 056.00 (46.30 %)	29.00	351 272.25
Kobbelv ( <b>KOB</b> )	2 499.00 (28.53 %)	36.50	536 728.25
<b>Average</b>	<b>4 421.28 (50.47 %)</b>	<b>28.27</b>	<b>240 381.55</b>

Water values, which highlight the value of the water in the reservoirs, decide whether the hydropower producers should produce or not. Therefore, it is important to model them correctly, considering that the analysis should be realistic. The values are based on the Capacity Factor Method. The water values originate from the long-term scheduling through the reasonable scheduling, as shown in Figure 3.2, but this coupling is not considered in our water value estimation. As the water values are dependent on the reservoir level, size of reservoir, type of hydropower plant (run-of-river, controllable, pumped storage), hydropower plants in cascade, restrictions on water level, uncertainty in market price etc., this means that water value estimation is much more complex than what this method shows, and therefore a coupling to long-term scheduling is needed. This coupling was not available in our case. The method applied in our case only takes operating time into consideration. This only reflects if a hydropower plant operated as a producer and sold energy, as the market price was higher than the water value, or not. A hydropower plant with a higher operating time than another hydropower plant would experience a lower water value, as the market price in NO4 more frequently was higher than the water value for this given hydropower plant. This method does not address the complexity of many of the dependent variables described above, and may therefore have given a false impression of the actual water values at the given time. Water values are the driving forces of production patterns in a STHS, and could potentially have decided that the wrong hydropower plant needed to produce at a given time, but this method gave us the most accurate water values for our purpose. Water value calculation was not the goal with this thesis.

#### 5.4 Start reservoir levels

The initial reservoir level is an important aspect to take into consideration when conducting an analysis on the hydro producers' decision making. In some cases the desired production might not be a possibility should the reservoir level be close to the lower limit, or on in other cases where spillage is experienced, and the water value drops to zero. The reservoir levels were for the purpose of this analysis set to the typical level of the first week in January. The data was obtained by using NVE's data base Sildre. However, some of the reservoir levels were not present in the data base, thus they had to be decided by another way. As the period of the analysis was set to be the first week in January, the reservoir levels are typically high, as the producers have planned the production throughout the winter where the inflow to the reservoirs are generally low, therefore the rest of the reservoir levels were initiated as 80% of max capacity.

The reservoir levels in the Norwegian power market are often a hot topic in the media, and the low reservoir levels in southern Norway, combined with low wind power production and high coal-, gas- and  $CO_2$ -prices, have contributed to the high power prices south of NO4 this spring [49]. NVE collects data on the reservoir levels of around 31 % of the hydropower plants (considered as the most important ones) in Norway every week [50]. This is done to keep track of the power situation in Norway at all times. In 2021, the average reservoir level at these power plants was measured at 78.1 % in the first week of January, which is almost as high as the top measurement of 78.8 %. Therefore, it was reasonable to assume a filling degree of around 80 % for the hydropower plants in our system. In comparison, the reservoir level was 53.1 % the same week in 2022, where the lowest measurement registered is 42.7 %. Such fluctuations in reservoir levels will clearly affect the decisions of Norwegian hydropower producers, which in turn will affect the power prices. A more interconnected European power market means that Norwegian power prices are even more reflected of the power prices in Europe in situations with low reservoir levels.

#### 5.5 Line data

The constructed power system accurately reflects today's power grid, and this means that the analyzes carried out in Chapter 4.2.4 provide a realistic picture of the current situation. NVE

provided line data for all lines, where resistance, reactance, voltage and other information were included. As derived in Section 3.4, the information of interest is the susceptance matrix  $B$ . The susceptance is also known as the complement of reactance, and in the DC OPF it is assumed that  $R = 0$ . The reactance value for each line is therefore the only information used to determine and build the power grid in the model. It is important to model the power grid correctly as line data determines phase angles, flow and production, as shown in Restriction 4.10 and 4.11. Large parts of the central grid in NO4 are still at 132kV, while only the southernmost parts have upgraded the grid to 420kV. Higher voltage on the central grid means that the losses are reduced (you can transfer more power) due to higher cross-sections and thus less resistance. An increase to 420kV is a measure to avoid expansion of the power grid, but it must be analyzed in a cost perspective.

Line data of the central grid was acquired from NVE, as stated in Section 5.5. Only the susceptance matrix  $B$  have to be developed, and therefore only the reactance is of interest. Restriction 4.10 and 4.11 determines the phase angles and power flow, in addition to the production coupling to the hydropower production.

Large parts of the central grid in NO4 are still at 132kV, while only the southernmost parts have upgraded the grid to 420kV. Higher voltage on the central grid means that the losses are reduced (you can transfer more power) due to higher cross-sections and thus less resistance. An increase to 420kV is a measure to avoid expansion of the power grid, but it must be analyzed in a cost perspective. It could thus be of interest to run this type of model with the future power grid. Any developments on critical lines can give an indicator of which lines that should have the highest priority, and how the power flows in a meshed network gets affected by these expansions (either upgrading to 420kV or install parallel lines). By reducing the resistance in one line, this could change the power flows, which further can affect the production planning if another line reaches its capacity limit. Hence, the development of the power grid is a complicated assessment, as fixing one bottleneck will only move the bottleneck to another place in the system, as seen in the power grid in Finnmark [43]. With the future increase in both demand and production it will be interesting to analyze how the power grid must look like to take this increase into account. The increasing power flows in the power grid will clearly require expansion of the grid, but a smarter grid and incentives to reduce power peaks are also an essential part of future development.

## 5.6 Demand

Northern Norway is an area based on surplus of power after the market algorithm is cleared, and a great amount of the produced power are going to cover the large loads in southern Norway. The natural flow of power is thus out to the price zones SE1, SE2 and NO3, which is further discussed in Chapter 4.2.4.

Hourly consumption data from the first week in January 2021 is obtained from Nord Pool [20]. This consumption data regards NO4, but not where in NO4 the actual demand belongs. To create the power flows, and decide which nodes the hydropower production have to cover, the population and industry in NO4 have to be analyzed. This determines the proportion of the total load in NO4 the different nodes in our system consume.

The loads in the system are based on population in NO4. There are 480 740 [51] people living in the counties Nordland and Troms & Finnmark, where towns down to around 1% of the total population have been included in the scaling of the load. This means that approximately 43.63% of the total load has been covered. Since the model does not include 100% of the population, thus the total load data for each individual hour is scaled by a factor of 0.4363. Consumption data is provided by Nord Pool. In addition to the load being scaled down due to only including 43.63% of the population, it must be scaled down even more as the model does not include all

the hydropower plants in NO4. From the hydropower database provided by NVE, the regulated hydropower plants in this model account for 26.82% of the installed capacity in NO4 [52], which means that the load must be scaled down even more. The total load data for each individual hour were then scaled by a factor of 0.2682.

As shown in Table 5.2, several of the largest towns are located in the south of NO4. As this model only consists of hydropower plants north of Kobbelv, an additional node must be constructed to take into account the load south of Kobbelv, called *Rest of NO4*. One additional node had to be constructed as almost 30% of the population live in and around Tromsø, but none of the existing nodes can represent this share of the load. The remaining towns could be connected to one of the existing nodes. This gives 6 nodes with generation, 7 nodes with load and 6 nodes with both generation and load, as shown in Tables 4.1 and 5.3.

The nodes in the different price zones SE1, SE2 and NO3 are only load nodes. The load in these nodes are based on the actual transfer of power during this period, as most of the transferred power between the zones flow over the modelled lines. As there are two nodes in SE1 (Ritsem and Tornehamn), the load is divided equally between these. Apart from the load being weighted by population, there are also two large industrial plants with high power consumption. Elkem Salten and Finnfjord produces Ferrosilicon and they are respectively located near Kobbelv and Bardufoss. Elkem Salten has a yearly demand of 1096 GWh, which is an hourly demand of:  $\frac{1096 \cdot 1000 \text{ MWh}}{8760 \text{ h}} \approx 125.11 \text{ MW}$ . Finnfjord has a yearly demand of 788.4 GWh, which is an hourly demand of:  $\frac{788.4 \cdot 1000 \text{ MWh}}{8760 \text{ h}} = 90 \text{ MW}$ . Consumption data has been received by the respective companies and relatively flat consumption is assumed for both industrial plants.

Table 5.2: Weighted nodes for consumption data

Town	Population	Node	Share of load
Bodø	40 705 (8.47 %)	Rest of NO4	18.51 %
Tromsø	38 980 (8.11 %)	Tromsø	17.73 %
Harstad	20 953 (4.36 %)	Niingen & Småvatna	9.53 %
Mo i Rana	18 685 (3.89 %)	Rest of NO4	8.50 %
Tromsdalen	16 787 (3.49 %)	Tromsø	7.63 %
Alta	15 094 (3.14 %)	Alta	6.86 %
Narvik	14 261 (2.97 %)	Håkvik, Lassajavri, Nygård & Sildvik	6.49 %
Mosjøen	9 841 (2.05 %)	Rest of NO4	4.48 %
Kvaløysletta	8 681 (1.81 %)	Tromsø	3.96 %
Hammerfest	8 052 (1.68 %)	Nedre Porsa	3.67 %
Fauske	6 251 (1.30 %)	Rest of NO4	2.84 %
Sandnessjøen	6 043 (1.26 %)	Rest of NO4	2.75 %
Sortland	5 345 (1.11 %)	Niingen & Småvatna	2.43 %
Brønnøysund	5 070 (1.06 %)	Rest of NO4	2.32 %
Vadsø	5 064 (1.05 %)	Adamselv & Offervatn	2.30 %
<b>Total</b>	<b>209 732 (43.63 %)</b>	<b>Total</b>	<b>100 %</b>



It is worth noting that we use the definition of town, and not municipality. This means that the municipality of Tromsø, which contains both Tromsdalen and Kvaløysletta, will be separated into their respective towns. Overall, there is no difference, as these towns will belong to the node of Tromsø, and consumption will be the same, as shown in Table 5.3.

Table 5.3 shows how the load distribution over the system aligns after the population connected to the same nodes are combined. This weighting is after Finnfjord (Bardufoss) and Elkem Salten (Kobbelv) have received their respective 90MW and 125.11MW. The last two columns in Table 5.3 shows a low load hour of 745MW in period 1 and a high load hour of 822.5MW in period 161, and how the load distribution aligns over the nodes given the percentage of the total load.

Table 5.3: Weighted nodes for consumption data

Node	Share of load	Low load [MW]	High load [MW]
Rest of NO4	39.40 %	293.53	324.06
Tromsø	29.32 %	218.43	241.16
Niingen & Småvatna	11.96 %	89.10	98.37
Alta	6.86 %	51.11	56.42
Håkvik, Lassajavri, Nygård & Sildvik	6.49 %	48.35	53.38
Nedre Porsa	3.67 %	27.34	30.19
Adamselv & Offervatn	2.30 %	17.14	18.92
<b>Total</b>	<b>100 %</b>	<b>745</b>	<b>822.5</b>

The demand is based on the population and largest industry in the area. A great amount of the people living in NO4 are located further south in the region, as shown in Table 5.3. Around 50 % of the population is taken care of and represents the actual population in a good way. We would only observe minor differences by modeling the rest of the population, as the largest towns will in any case take the majority of the consumption. Actual data on the industrial buildings Finnfjord and Elkem are received by the respective companies.

The most critical point of the modelling of the demand regards the the other zones: NO3, SE1 and SE2. As there is no production in these areas, there will only be flow in one direction. It is not relevant to model demand in NO3 as *Rest of NO4* is the node above, and there is no production there as well. By having a larger part of a meshed network that contains production in the other zones NO3, SE1 and SE2, modelling of demand in these zones would be much more interesting as well. A radial network with no production in the other zones is not able to represent the dynamics of today's power market.

## 6 Results

First, the results from the base case is presented to show how the system behaves without any restrictions. Then, different line restrictions are introduced to show the effect of these limitations, and how the production level adjust by taking the limitations of the power grid into account.

### 6.1 Base case

The base case of the analysis consists of hydropower power plants and loads at the nodes as given in Table 4.1 and Table 5.2. There are no line restrictions on power flow between the nodes. The water value for the hydropower producing nodes are defined for the end period of the scheduling horizon.

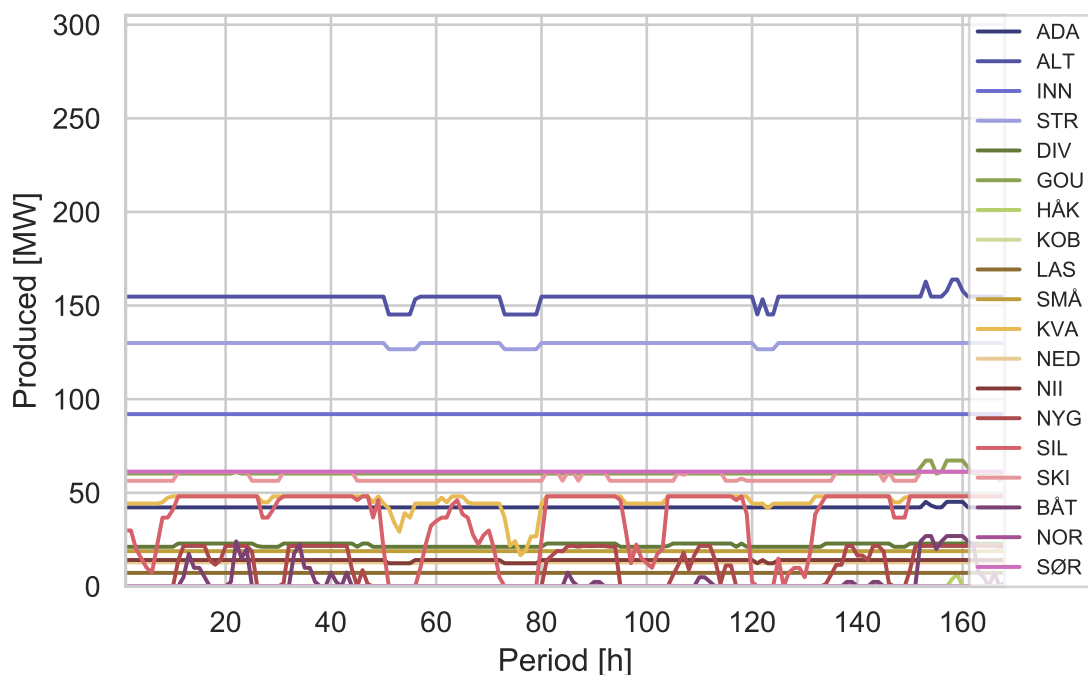

Figure 6.1: Power produced at each hydropower plant with no capacity restrictions

The producing units for the base case can be seen in Figure 6.1. The plot visualizes how the hydropower scheduling would have been conducted today, meaning it is the same as if the reservoir had been aggregated into a big reservoir to cover the demand, using only the cheapest plants to produce the required amount of power.

The solution of the base case is something to expect in a situation where no restrictions or topology is taken into account. The only aspect that decides the producing units, is the value of the water used to produce the required amount of power. Therefore, the nodal prices in the system is the same, implying a common system price in all periods of the analysis.

Looking at the producing units, it's possible to observe how Norrdalen doesn't produce in this case even though the water value at the affiliated reservoir is the lowest in the system. The water values are presented in Table 5.1. This occurs due to the efficiency of the power plant, which makes it less favorable to produce, as you have to use a larger amount of water to produce the same amount of power compared to plants with higher water value, making it

less economically favorable. On the other hand the plants covering the largest share of the load is Alta and Straumsmo, given the low water value of the affiliated reservoirs together with the efficiency of the plants. The variations seen in Figure 6.1 are expected fluctuations due to the varying demand in the region seen throughout the whole period.

## 6.2 Case 1 - Ofoten bottleneck

In this case the well-known bottleneck around Ofoten has been imitated where the power plants in the northern part of NO4 lacks the possibility of covering the demand south of Ofoten. The goal is to highlight and observe how the internal limitations and characteristics of NO4 creates an decoupling within NO4, and initiates production at more expensive hydropower plants.

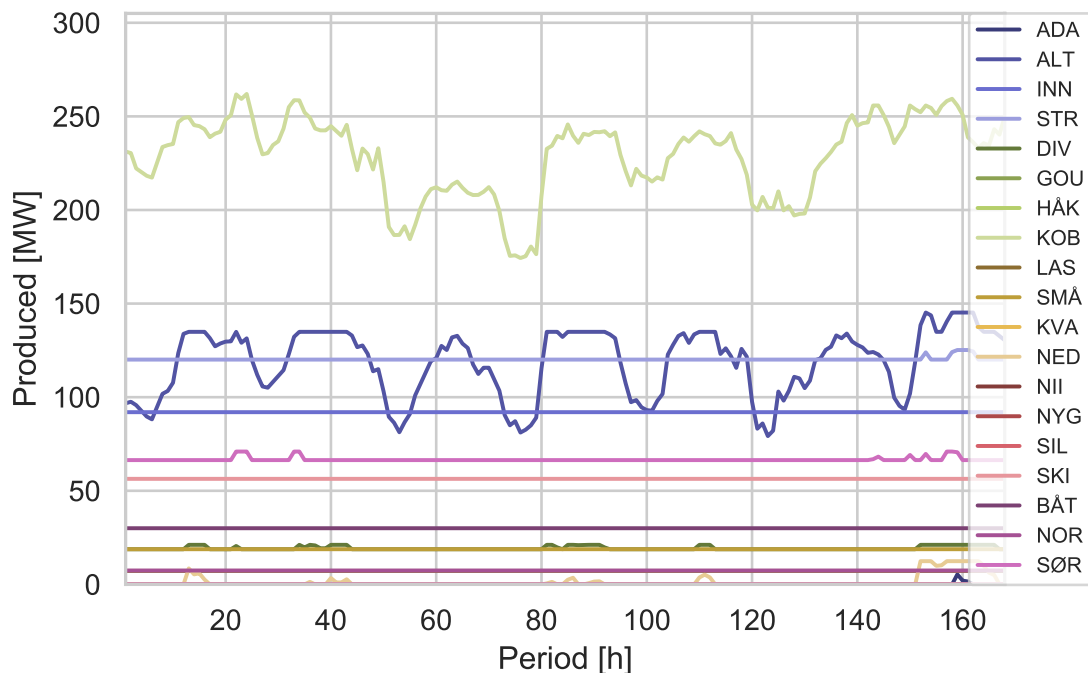

Figure 6.2: Power produced at each hydropower plant with capacity restrictions between north and south in NO4

The power flow on the line between Haakvik and Båtsvatn is at max capacity throughout the whole period, as expected. The location of the largest loads are in the southern part of NO4 while the cheapest production is located at nodes north of the bottleneck at Ofoten, meaning the system will utilize the capacity of the restricted line at full extend. The rest of the system adjust after the flow in the restricted line is set, and the new production pattern can be seen in Figure 6.2.

The solution with the new restriction introduces a decoupling between the northern and the southern part of NO4. The northern part has a surplus of cheaper power resulting in a lower nodal price for the nodes located in the region, while the southern part experiences the opposite with a higher nodal price. This can be seen in the changes in production pattern. Norddalen for instance, is producing a constant amount throughout the period, as the topology of the nearby grid together with the adjacent plants require it to produce. This contributes to the increase in nodal prices nearby. It is also notable how Kobbelv in this situation covers a large amount of the load even though it has the highest water value. This is a result of the radial grid surrounding

the plant, as the resistance in a radial system highly affects the location where production takes place, due to how power flow is generated. These changes in production pattern is a result of over- and underproduction in the original production schedule, the changes can be seen in Figure 6.4i and 6.5ii.

### 6.3 Case 2 - East to west bottleneck in Finnmark

The last case highlights an issue surrounding the internal transmission capacity in Finnmark. To date, concession for around 400 MW wind power in Finnmark has been issued [53]. The challenge is the location of the wind parks in question, the majority lies east in Finnmark where the transmission grid already face challenges with capacity. The goal in this case is to see how the restrictions present in the grid already causes price decoupling within Finnmark, without the prospective wind parks.

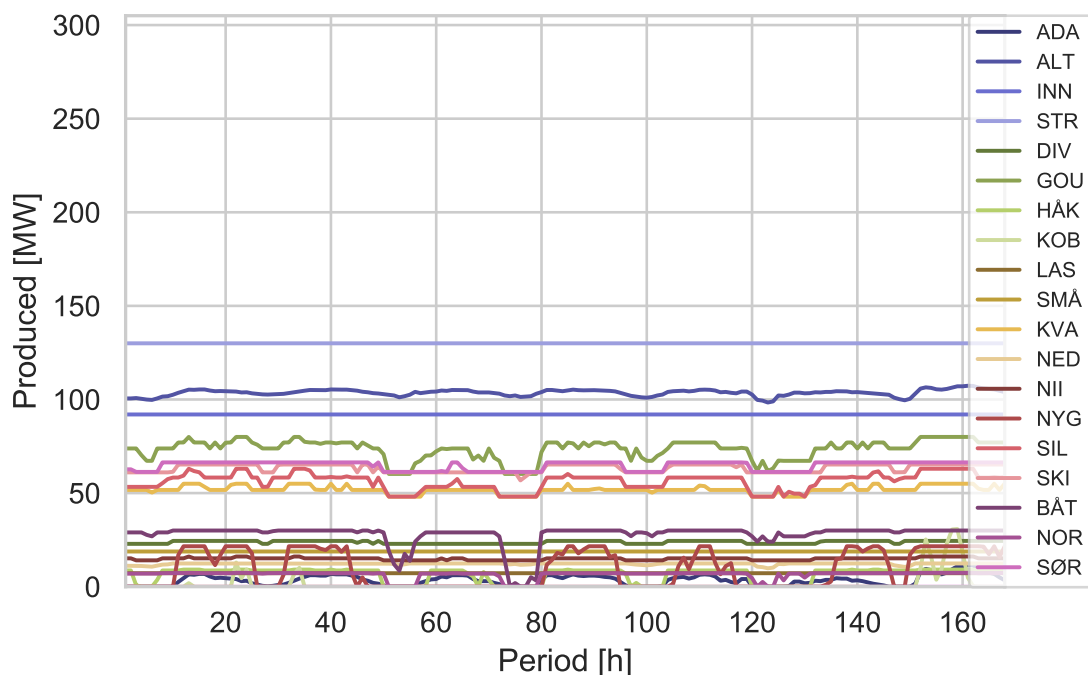

Figure 6.3: Power produced at each hydropower plant with capacity restrictions between east and west in Finnmark

The power flow on the line between Alta and Kvænangsbotn is at max capacity throughout the whole period and therefore creates a bottleneck, while the power flow between Nedre porsa and Kvænangsbotn balances around the limit occasionally creating a bottleneck. Similar tendencies are seen in this case compared to the base case. The system utilizes the capacity of the restricted lines almost at max for both lines throughout the period causing change in the production pattern highlighted in Figure 6.3.

Also in this case there will be an decoupling around the area experiencing congestion within Finnmark. The eastern part has access to cheaper power resulting in lower nodal prices. This is due to production in the region taking place at some of the cheaper plants in the system and due to the capacity of these power plants being below the production capacity. The hydropower plants in the decoupled eastern area need to cover a decreased share of the total load giving the opportunity to use less of the more expensive water. This can be seen in the production pattern

of Adamselv who rarely covers any load in this case as other plants in the region, such as Alta, is cheaper and has capacity to cover much of the decreased load. The change in production pattern for Adamselv can be seen in Figure 6.4ii.

## 6.4 Quantitative results

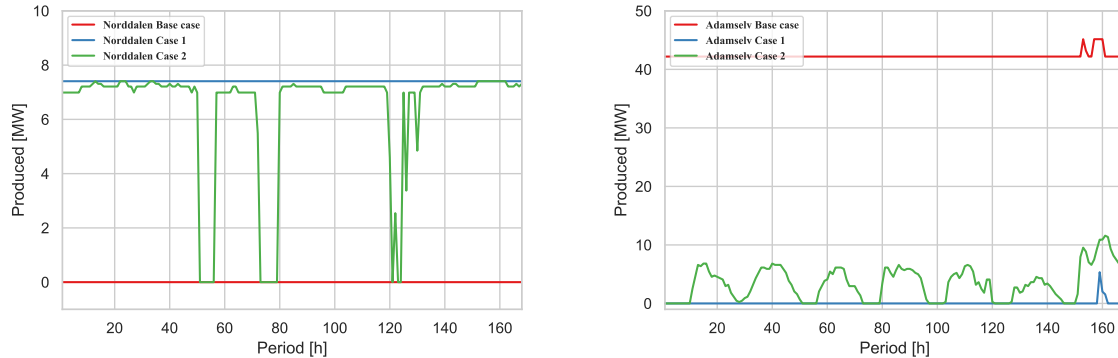

(i) Power produced at Norddalen hydropower plant in all optimization cases (ii) Power produced at Adamselv hydropower plant in all optimization cases

Figure 6.4: Production in all optimization cases

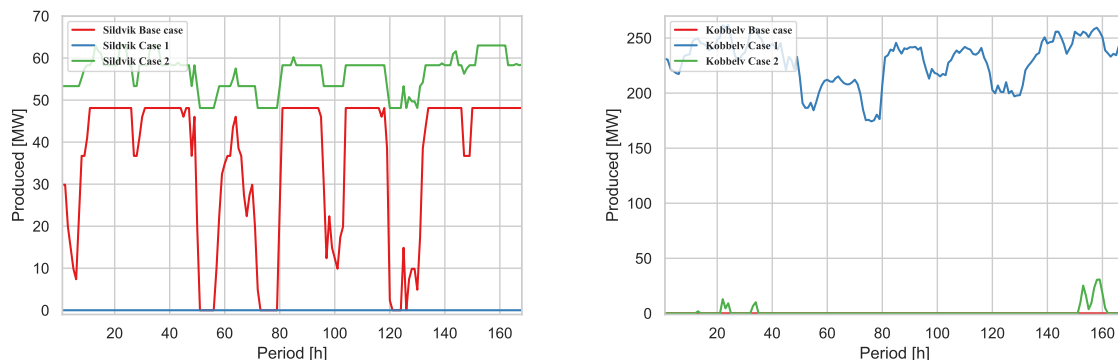

(i) Power produced at Sildvik hydropower plant in all optimization cases (ii) Power produced at Kobbelv hydropower plant in all optimization cases

Figure 6.5: Production in all optimization cases

As previously mentioned it's striking that Norddalen does not produce in the base case given the water value of the plant which is the lowest in the system by far. However, the cost of the water used will also be affected by the technical aspect of the hydropower plant. Norddalen is also the plant with the lowest efficiency. This implies that despite the low water value, it will be more costly to produce at this plant compared to more efficient plants in the system. The production at Norddalen is sensitive to the capacities of the system. From the base case to case 1 the production at the plant increases from 0 MW to 7.4 MW, as seen in Figure 6.4i, implying that decrease in transmission capacity will initiate production at the plant. This differs from the optimal solution, ultimately leading to use of more expensive water to cover the load obligation. The tendency can also be seen in case 2, where the power production at the plant is initiated in peak hours of operation. The hydropower plant experiencing the greatest increase in production is Kobbelv. Between the base case and case 1 the production increases drastically, as seen in

Figure 6.5ii. Kobbelv has the highest water value in the system, which the higher nodal prices for this case reflects. Additionally, the high production will imply that a large amount of water is used. In this case the reservoir level at kobbelv decreases from  $319 \text{ Mm}^3$  to  $295 \text{ Mm}^3$  over the whole week, a decrease from 80 % to 74 % filling degree. By analyzing a two-week period in addition to years with much lower filling degree, Kobbelv would probably not produce as much. The change in water value becomes more observable at low filling degrees, which entails that hydropower producers would have to store the water for periods where they expect to get paid more for the expensive water. Sildvik and Adamselv also experience drastic changes in the production pattern, highlighted in Figure 6.4ii and 6.5i. The effect on the objective value (the value of the water used), reflect these findings. The base case has the lowest objective value, while case 1 experiences the highest objective value. The tendencies are highlighted for a selection of plants in Figure 6.4 and Figure 6.5. The variations seen in production between the cases clearly highlight the influence of the power grid in the production schedule.

## 6.5 Nodal prices and objective values

The nodal prices for all cases are presented in Table 6.1. To highlight the differences, the nodal prices are presented for a low load hour and a high load hour.

Table 6.1: Nodal prices and objective value for all three cases

	Base case		Case 1		Case 2	
	Low load	High load	Low load	High load	Low load	High load
Node 1	301.4	308.8	268.2	274.3	271.6	281.0
Node 2	301.4	308.8	268.2	274.3	271.6	281.0
Node 3	301.4	308.8	268.2	274.3	271.6	281.0
Node 4	301.4	308.8	268.2	274.3	268.2	268.2
Node 5	301.4	308.8	268.2	274.3	274.5	291.8
Node 6	301.4	308.8	268.2	274.3	329.3	366.3
Node 7	301.4	308.8	268.2	274.3	329.3	366.3
Node 8	301.4	308.8	268.2	274.3	329.3	366.3
Node 9	301.4	308.8	268.2	274.3	329.3	366.3
Node 10	301.4	308.8	268.2	274.3	329.3	366.3
Node 11	301.4	308.8	268.2	274.3	329.3	366.3
Node 12	301.4	308.8	268.2	274.3	329.3	366.3
Node 13	301.4	308.8	268.2	274.3	329.3	366.3
Node 14	301.4	308.8	366.3	374.7	329.3	366.3
Node 15	301.4	308.8	366.3	374.7	329.3	366.3
Node 16	301.4	308.8	366.3	374.7	329.3	366.3
Node 17	301.4	308.8	366.3	374.7	329.3	366.3
Node 18	301.4	308.8	366.3	374.7	329.3	366.3
Node 19	301.4	308.8	366.3	374.7	329.3	366.3
Node 20	301.4	308.8	366.3	374.7	329.3	366.3

As expected, the base case solution will be the most profitable. There are no restrictions on power flow, and the hydropower plant with lowest water value will always produce up to its maximum production capacity. Alta, Straumsmo and Innset covers large parts of the load in the base case, as visualized in Figure 6.1. One uniform system price is expected in this case without congestion issues, where the next MW of power (reduced cost to Restriction (4.10)) at any node can be covered by the cheapest hydropower plant with available production capacity.

Case 1, with a capacity constraint on 40 MW between Håkvik and Båtsvatn (Ofoten bottleneck),

represents a case where congestion influences the nodal prices in a way we can observe in the Nordic Market today. The cheap hydropower plants Alta, Straumsmo and Innset are located north of the bottleneck and will cover most of the load here. The nodes north of the bottleneck experience a lower nodal price than the base case due to this. Kobbelv did not produce in the base case, but has to cover a large amount of the load in this case. The nodal prices south of the bottleneck are influenced by the substantial increase in production at the most expensive hydropower plant.

Case 2 experiences a situation where node 4 (Alta) achieves the lowest nodal price, without coupling to any other nodes. The capacity constraint between Alta and Kvænangsbotn (node 4 and 6) is always maximized, creating a bottleneck and big price differences between the areas. Alta covers most of the load in the eastern part of this bottleneck, while Nedre Porsa (node 5) also starts its production. Node 1, 2 and 3 are influenced by the production at Alta and Nedre Porsa. The western part of the bottleneck experiences a uniform price due to the restriction on power flow.

The objective value and average nodal prices for the 3 different cases are presented in Table 6.2, and they are compared to the base case:

Table 6.2: Total costs and nodal prices for the different cases

Case nr.	Value [NOK]	Difference [%]	Average nodal price - Low/high [NOK/MWh]
Base case	24 856 974	0	301.4/308.8
Case 1	28 000 994	+12.65%	302.5/309.4
Case 2	25 431 462	+2.31%	314.9/344.9

The average nodal price must not be confused with the system price. As a large part of the load is located in the south in the system, this entails that the expensive hydropower plants have to cover a great deal of the total load in case 1. This results in an increase of around 12.65 % from the base case. The increase from the base case to case 2 is 10 % lesser compared to case 1. The cheap hydropower plants Alta, Straumsmo and Innset will again produce much, like base case. The average nodal prices do not weight the actual production level for the given hydropower plants, and only gives an indication on the average price for the next produced MW.

## 7 Discussion

In this thesis, an optimization model combining STHS with OPF has been developed and used to carry out an analysis in the case study. This has enabled better insight surrounding the challenges connected to production planning for hydropower producers, and how the decisions will be affected when the grid topology and attributes are included in the problem. To what degree do the characteristics of the plants influence the decision on which plants produce in certain situations? The discussion will also investigate the shortcomings by using LP to solve a problem that in reality will have non-linearities and a possible need for a stochastic model, and how the available data limits the extend of the analysis.

Section 7.1 discusses how the analysis were affected by the simplifications made. Section 7.2 summarizes the findings made in the case study. Section 7.3 expands the analysis to see what value this model can have for the involved market participants. Section 7.4 discusses different methods for managing congestion in the power grid. Section 7.5 shortly illustrates the difference of a nodal and zonal approach. Section 7.6 discusses possible further research within the subject area.

### 7.1 Optimization model and data

The literature review presented in Chapter 2 indicates that there is no previous research combining a detailed power grid together with hydropower scheduling in a short-time planning algorithm. The developed optimization model will be able to analyse how the hydropower producers are affected by grid restrictions in a one-step algorithm.

For the purpose of the thesis we developed an optimization model to conduct the analysis. To make a realistic yet efficient model, some simplifications and assumptions were made. Reasonable assumptions will influence the optimal solution, possibly resulting in a solution that might be infeasible. By using LP to clear the market, valuable data such as nodal prices can be obtained through the dual values. At the same time, linearizing a large-scale problem implies that information about the system behavior is neglected. The PQ-curves used in the model are in reality not piecewise linear, the efficiency of the hydropower plants will vary across the segments. Overestimation of the power output could happen in the linear approach. This can occur if the plant must operate at a lower point of the segment to meet obligations, like environmental constraints [54]. As the penstock losses (head- and frictional losses from source to turbine) are not implemented, this could also cause overestimation. SINTEF Energy discussed a way of incorporating these losses in the unit PQ-curves [55]. The purpose of this analysis was to observe whether the production planning for the hydropower producers changed by including the bottlenecks in the short-term algorithm. The simplifications done in the model still confirms this purpose, but the results are too simple to make plans that are implemented directly by a power plant.

In addition, by using the DC approximation, power losses will among other information be neglected. Neglecting the power losses will lead to uncertainty about the optimal power dispatch in the model. The proposed solutions might not be realistic, or even the optimal solution in the analysed system. However, DC OPF is commonly used in solving the market clearing, and as mentioned in Section 3.4.5, transmission systems experience little of the neglected aspects of the DC OPF. Thus, the linearized optimization model developed in this thesis serves its purpose.

### 7.2 Case study

The case study simulations highlighted that the existing power grid will experience challenges in relation to the capacities under normal operating conditions. The grid has areas with scarce transmission capacity, causing a surplus of cheap power left unused, leading to variation in the



nodal prices. The case study aims to minimize the cost of covering the demand in the system. The base case is a representation on how the production scheduling is conducted today with network topology neglected. Cases 1 and 2 visualize the challenges encountered in the current grid of NO4.

In the base case, where no restrictions on power flow were introduced in the problem, the system obtained what could be perceived as the optimal solution to covering the load with equal prices in all nodes, implying a common system price. The prices, as seen in Table 6.1, shows that the system is able to portion out the cheapest water throughout the whole period, leading to small equal prices at all nodes within each period. The only difference is in peak-periods, where the system price increases as the cheapest plants max their capacity. The flow on the lines keeps, as expected, below the limits in the case where the system experiences no restrictions, meaning bottlenecks and congestion are not a concern. In a system with more than enough capacity this would be the case, and the hydropower producers could make decisions solely based on the production cost. Cases 1 and 2 represent a more precise representation on how the production planning is affected by the possibilities in the grid. The new production pattern highlight the issues with neglecting the capacities in the grid.

### 7.3 Value for market participants

The results of the analysis raises some interesting questions surrounding which of the market participants who will benefit from introducing the algorithm developed in this thesis. Seen from the producers point of view, it would be beneficial to see the actual potential for power delivery, as they aim to maximize their revenue. At the same time, the TSO will aim to operate the grid as smooth as possible, avoiding congestion if possible. Detailed information about the system will entail smarter decisions, both for the producers and the TSO. In addition, consumers would also be affected as the market price would often vary between the nodes.

After the day-ahead market is cleared, the TSO will do a load flow simulation to locate potential bottlenecks in the grid. The base case will give a good representation on how the day-ahead market is cleared. If the production plan result in transmission lines being overloaded, the TSO will have to act through the balancing market to alleviate the overloaded lines. This is done by either paying producers to increase or decrease their production, given the up- and down-regulation bids from the producers. The TSO will aim to minimize the cost for regulation. The results seen in case 1 and case 2 highlight how the production would be if the most important capacity limitations were included in the production planning. In reality the production pattern could be entirely different, due to variations in the regulation bids from the producers.

The submission bids from the producer to the power market would account for the capacity in the nearby grid, meaning they effectively could avoid overbidding to the market. The producers located in power surplus areas often experience low electricity prices. By applying the developed algorithm from the producers perspective, the undesirable low prices could be avoided. The market bids will come as a direct result of deeper knowledge about the market situation and possibilities. At the same time, this implies that the producers could be able to see where it would be smart to take advantage of the bottlenecks in the power grid. The producer could offer power equal to the marginal cost of production, even though its not feasible, because of scarce capacity in the grid. By doing so, the market would need regulation. This would initiate regulation in the balancing market, which often implies an increase in profit for the producer. The producer could also offer less power to the market than the water value indicates, to construct deficit areas. Deficit power areas would require up-regulation at certain power plants to cover the demand. Up-regulation is costly as the TSO will have to pay plants to deliver the required amount of power to achieve power balance. The producers would be incentivized to do so, as they could expect higher profit from up-regulation than their market price forecast. Regulation from the

TSO would imply that the flexibility of the system decreases, meaning a loss of socio-economic surplus [56]. Nevertheless, the direct outcome of this knowledge would be difficult to foresee and will need further research to be able to conclude. In addition, the producers could face penalties from regulative authorities if they try to manipulate the market.

Contrary to the producers, the TSO will try to avoid situations where the need for up- and down-regulation occurs. An optimization model with deeper knowledge of the power system offers the TSO greater insight in where the potential problem areas will be located. This gives the TSO a good starting point for assessing which bids seems reasonable in the balancing market, facilitating for optimal utilization of the power grid. Although, this will be challenging as the bids from the producers will be coupled to the water value at the specific plant. The water values are not public information, making it difficult to assess if the bids are reasonable or not. Therefore, an indication of the water value could be necessary to fully be able to evaluate the bids.

The electricity price is often difficult to interpret for the consumer, and the large fluctuations between the different price zones is a cause of debate in the society. By applying the developed algorithm the prices would still vary as the limitations in the grid is still present. At the same time, the consumer could be more certain that the price for electricity would reflect the actual cost of production.

#### 7.4 Effects of different congestion management methods

As presented in Section 3.5.2, there exist different solutions to keep the power flow within the limits present in the grid. FBMC is a method which entails a more accurate representation of the power flow in the system than the present solution in the Norwegian power system (ATC). In the future, the method will be implemented in the Norwegian system, alleviating the TSO of its responsibility of handling the physical flows between the bidding zones. This would be beneficial to the society as an accurate representation of the grid will lead to an increase in social welfare [57]. Thus, it seems reasonable to assume that increasing the complexity of the grid and power flow modelled would imply better solutions when clearing the market. Although, the internal bottlenecks could still pose a challenge, as the clearing method mainly deals with the critical lines between the bidding zones. DC OPF will be an accurate approach to how the power flow will be distributed in the power grid, both between the zones and internally. At the same time, the model will be comprehensive, as it will require detailed information about all the lines in the system.

#### 7.5 Nodal and zonal approach

A nodal approach was chosen in the developed optimization model. This differs from the current market clearing mechanism used in most of Europe, where a zonal approach is preferred. The nodal approach would require a great amount of information about the power systems attributes. In depth information about the grid would be a comprehensive task to acquire, which makes the zonal approach a reasonable compromise. The challenge with the zonal approach becomes evident when the internal bottlenecks affect the possible power flow between the zones. Previous studies, as mentioned in Chapter 2, have investigated the possibility of using a nodal approach in a country where the connected countries used a zonal approach. The conclusion highlighted that using a nodal approach would be both possible and beneficial. On the other hand, by having fewer, bigger zones, the financial market is easier to run. The financial market is introduced to secure the market participants for the fluctuations in price, where contracts up to ten years can be signed. A zonal approach with large zones would imply that a greater geographical area has the same price, and the financial settlement of the future- and forward contracts are easier to manage. The nodal approach entails different area prices for every active bottleneck in the

system, and the forward contracts, which covers the difference between the system price and the area price for the members, must enter the financial market and make up for this difference.

## 7.6 Future work

The case study of this thesis has highlighted how the combination of STHS together with DC OPF introduces new production patterns for hydropower plants in NO4. However, the real transmission grid consists of many other power sources in addition to hydropower plants. Other renewable energy sources such as solar and wind power are highly relevant for an analysis on the production pattern. Both are volatile non-regulative energy sources, which would affect the spot market price when producing, and in the future wind power penetration is expected to increase in NO4 and the power market in general. The surplus of wind power in the northern part of Sweden also affects this, as they will not always be able to buy the surplus from the Norwegian side in hours of high wind power production. It would be expected that the increase in wind power would enable more decision room for the hydropower producer, making them able to take more cost-efficient decisions on when and where to produce. Some type of collaboration between the hydropower plants and wind farms could be beneficial and could cause better utilization of the existing power grid. Including these type of power sources would imply building a stochastic optimization model, as scenarios for wind would have to be generated. A valid question to raise would then be what could the balancing market be used for. Many of the issues dealt with by the balancing market is extinguished by using a one-step algorithm as in this thesis. A possible way to utilize the already existing balancing market could be to deal with the large fluctuations in production from some renewable energy sources and possible outages creating the need for regulating the power output. Nevertheless, only hydropower plants were modelled in this thesis, more complex algorithms would have to account for the balancing market in some way.

The analysis conducted is limited by the available data. The model itself could be used to do a more comprehensive analysis if data on hydropower plants in the connecting bidding zones were included. As the bottleneck around Ofoten in reality includes the passage through northern Sweden to southern Norway, the analysis could further contribute to the decision making of producers, giving a more realistic representation of where the demand and production must take place. As seen in the nodal prices, the nodes in Sweden will follow the price from the connecting node on the Norwegian side. In reality this would be different in many situations, as power plants on the Swedish side also would contribute with load covering. In addition the transmission capacity between northern Sweden and southern Sweden is significantly larger than the north-south passage in Norway, therefore the majority of power transfer from the north to the south in Norway goes through this passage [58]. This would be important to include in an analysis as the one conducted in this thesis. The capacity between Ofoten and Ritsem could greatly influence the power flow in the system. An increase in capacity on this line, which is restricted at 600 MW even though the thermal limit is 1500 MW would initiate larger power flows from northern to southern Norway [59]. This could also affect the power price, as access to cheaper power in northern Norway would become more accessible. The fact that no plants or transmission grid are modelled on the Swedish side means congestion will not occur on the inter-border lines, as the capacities need to be set so that the load can be covered from the Norwegian side. It would be of great interest, given the current situation experienced in the power market, to see how the decisions would change production pattern and the influence on nodal prices, should hydropower plants and power grid on the Swedish side be included. Additionally the time span for the analysis could be extended to two weeks. This would especially be of interest in situations with low reservoir levels, as the inflow would to a larger degree affect the decision on where to produce.

The hydropower producer face numerous restrictions and obligations it need to fulfill to be allowed to operate. One of the advantages of hydropower is the possibility to regulate up

and down production whenever necessary, although this possibility come with some obligations. In many cases the hydro producers are imposed an environmental constraint, dictating the minimum discharge allowed, to keep for instance the fish stock on a satisfying level. In addition there are restrictions on the reservoir level, meaning the hydro producers will have to make sure they have a minimum amount of water available in their reservoir. This imply that the producers not always will have the opportunity to produce, even though it is desirable from an economic point of view. Therefore, including these type of restrictions in the optimization problem could provide an even more realistic analysis on how the production pattern would change.

## 8 Conclusion

This thesis has investigated the influence of including power flow equations in the short-term hydropower scheduling algorithm. The study conducted is motivated by the current situation experienced in the Norwegian power grid, where low reservoir levels in the south and scarce transmission capacity between NO4 and the rest of Norway has led to large price differences. The simulations use real data from hydropower plants in NO4, transmission lines and historical load data from Nord Pool for the first week of January 2021. Additionally required data has been constructed with methods presented in Chapter 4. The optimization model we developed is a deterministic linear approach to solving a multi-period DC OPF combined with STHS problem.

The results in this paper highlights the difference the inclusion of power flow equations in STHS could mean for the participants in the market. The new production pattern is due to the technical aspect of the power grid being considered alongside the production costs. The production decisions are highly dependent on the possibilities in the nearby grid. This is evident in the simulation cases. Both case 1 and case 2 highlight that less economical decisions has to be made compared to the base case because of the scarce transmission capacity in the grid. The results imply that the current method for STHS will entail both under- and overproduction, making the need for the intraday market evident.

The Norwegian market clearing is currently using a zonal approach, not considering the internal capacities. The balancing market is mainly dealing with the internal congestion of the bidding zones, meaning expensive re-dispatch has to be initiated in the second stage of the clearing algorithm. A model using nodal pricing, as done in this thesis, would imply a change to the market clearing mechanism currently applied in the Norwegian system. By utilizing a nodal approach the internal price signals could become more precise. Additionally, it could help identify areas with scarce access to power and congestion issues in the first stage.

It would be possible to implement a nodal pricing system, even though the neighboring countries apply a zonal approach and has a high share of wind power generation. Norway is affected by wind power from the interconnections to Europe, and could therefore benefit from a nodal approach. Identifying the internal congestion problem between the northern and southern part of Norway in the nodal approach could help the TSO to address the issue. The need for the balancing market would decrease if bottlenecks are foresighted. The consumer could benefit from this. The cost for re-dispatch could therefore decrease and congestion rent collection could increase. This could lead to a lower unit price compared to a model using only zonal prices.

## References

- [1] United Nations Climate Change. "The Paris Agreement" Accessed 4. march 2022 from. <https://unfccc.int/process-and-meetings/the-paris-agreement/the-paris-agreement>.
- [2] Regjeringen. "Klimaendringer og norsk klimapolitikk" Accessed 31. March 2022 from. <https://www.regjeringen.no/no/tema/klima-og-miljo/innsiktsartikler-klima-miljo/klimaendringer-og-norsk-klimapolitikk/id2636812/>.
- [3] D. Spilde et al. "Elektrifisering av landbaserte industrianlegg i Norge" Accessed 4. May 2022 from. [https://publikasjoner.nve.no/rapport/2020/rapport2020\\_18.pdf](https://publikasjoner.nve.no/rapport/2020/rapport2020_18.pdf). 2020.
- [4] NVE. "Hvor kommer strømmen fra?" Accessed 11. April 2022 from. <https://www.nve.no/energi/energisystem/kraftproduksjon/hvor-kommer-strommen-fra/>.
- [5] Lars Ragnar Solberg. "Flaskehalsen i kraftmarkedet" Accessed 8. April 2022 from. <https://www.duo.uio.no/bitstream/handle/10852/17550/LARS-RAGNAR-SOLBERG14.11.08.pdf?sequence=1>.
- [6] Statnett SF. "Analyse av transportkanaler 2019-2040" Accessed 7. May 2022 from. <https://www.statnett.no/globalassets/for-aktorer-i-kraftsystemet/planer-og-analyser/nup-og-ksu/analyse-av-transportkanaler-2019-2040.pdf>.
- [7] Julija Matevosyan, Magnus Olsson, and Lennart Söder. "Hydropower planning coordinated with wind power in areas with congestion problems for trading on the spot and the regulating market". In: *Electric Power Systems Research* 79.1 (2009), pp. 39–48.
- [8] Endre Bjørndal, Mette Bjørndal, and Victoria Gribkovskaia. "Simulation of congestion management and security constraints in the Nordic electricity market". In: *2012 9th International Conference on the European Energy Market*. 2012, pp. 1–8.
- [9] Mette Bjørndal and Kurt Jörnsten. "Zonal Pricing in a Deregulated Electricity Market". In: *The Energy Journal* 22 (Jan. 2001), pp. 51–74.
- [10] Mette Bjørndal and Kurt Jörnsten. "Benefits from coordinating congestion management—The Nordic power market". In: *Energy Policy* 35.3 (2007), pp. 1978–1991.
- [11] Viljar Stensaker Stave et al. "Optimal Utilisation of Grid Capacity for Connection of New Renewable Power Plants in Norway". In: *2021 International Conference on Smart Energy Systems and Technologies (SEST)*. 2021, pp. 1–6.
- [12] M. Eriksen and M. Espeland Trondal. "Optimal short-term hydropower scheduling in constrained areas" Accessed 7. March 2022 from. 2021.
- [13] Ida Andersen. "Regjeringen vil tildele områder for 30 GW havvind før 2040" Accessed 23. May 2022 from. <https://www.tu.no/artikler/regjeringen-vil-tildele-omrader-for-havvind-for-30-gw-innen-2040-i-norge/519422>.
- [14] NVE. "Kraftproduksjon" Accessed 11. May 2022 from. <https://www.nve.no/energi/energisystem/kraftproduksjon/>.
- [15] Endre Bjørndal, Mette Bjørndal, and Hong Cai. "Nodal pricing in a coupled electricity market". In: *11th International Conference on the European Energy Market (EEM14)*. 2014, pp. 1–6.
- [16] Andreas G. Vlachos and Pandelis N. Biskas. "Balancing Supply and Demand Under Mixed Pricing Rules in Multi-Area Electricity Markets". In: *IEEE Transactions on Power Systems* 26.3 (2011), pp. 1444–1453.

- [17] André Luiz Diniz et al. “Short/Mid-Term Hydrothermal Dispatch and Spot Pricing for Large-Scale Systems-the Case of Brazil”. In: *2018 Power Systems Computation Conference (PSCC)*. 2018, pp. 1–7.
- [18] Endre Bjørndal et al. “Hybrid pricing in a coupled European power market with more wind power”. In: *European Journal of Operational Research* 264.3 (2018), pp. 919–931.
- [19] Olje og energidepartementet. “Kraftmarkedet” Accessed 15. May 2022 from. <https://energifaktanorge.no/norsk-energiforsyning/kraftmarkedet/>.
- [20] Nord Pool. “Market data” Accessed 7. April 2022 from. <https://www.nordpoolgroup.com/en/Market-data1/#/nordic/map>.
- [21] Knut A. Rosvold and Lars Olav Askheim. “Transmisjonsnett i Store norske leksikon på snl.no.” Accessed 30. April 2022 from. <https://snl.no/transmisjonsnett>.
- [22] Statnett. “Kraftig forbruksvekst og industrialiseringsplaner gir behov for mer kraftproduksjon” Accessed 10. May 2022 from. <https://www.statnett.no/om-statnett/nyheter-og-pressemeldinger/nyhetsarkiv-2021/kraftig-forbruksvekst-og-industrialiseringsplaner-gir-behov-for-mer-kraftproduksjon/>. 2021.
- [23] Statnett SF. “Nettutvikling 2021” Accessed 4. May 2022 from. <https://www.statnett.no/globalassets/for-aktorer-i-kraftsystemet/planer-og-analyser/nup-2021/nettutviklingsplan-2021.pdf>.
- [24] Entsoe. “Alternative configurations of the Bidding Zone Review Region “Nordics” which are to be considered in the Bidding Zone Review Process” Accessed 5. May 2022 from. <https://www.statnett.no/contentassets/f4a33c4dd9504acbb44399298d8aa822/nordic-bzrr-alternative-configuration.pdf>.
- [25] CenSES. “Norsk vannkraft kan fungere som et batteri for Europa” Accessed 4. May 2022 from. <https://www.ntnu.no/documents/7414984/1282265106/Norsk+vannkraft+som+batteri+for+Europa.pdf/3727e283-58e0-477a-a47a-4bc2b7512e0b>.
- [26] S. Tveitdal. “1.5 grader er kjørt - 2 grader innen rekkevidde” Accessed 28. March 2022 from. <https://energiogklima.no/meninger-og-analyse/kommentar/15-grader-er-kjort-2-grader-innen-rekkevidde/>. 2021.
- [27] O.B. Fosso and M.M. Belsnes. “Short-term hydro scheduling in a liberalized power system”. In: *2004 International Conference on Power System Technology, 2004. PowerCon 2004*. Vol. 2. 2004, 1321–1326 Vol.2.
- [28] Julija Matevosyan and Lennart Soder. “Optimal Daily Planning for Hydro Power System Coordinated with Wind Power in Areas with Limited Export Capability”. In: July 2006, pp. 1–8.
- [29] Mari Haugen et al. “On the Importance of Detailed Thermal Modeling for Price Forecasting in Hydro-Thermal Power Systems”. In: *2019 IEEE Electrical Power and Energy Conference (EPEC)*. 2019, pp. 1–6.
- [30] R. Fernandez-Blanco Carramolino, I. Hidalgo-Gonzales, and K. Kavvadias. “Water-related modelling in electric power systems”. In: *Joint Research Senter (European Commission)*. 2018, pp. 12–20.
- [31] Arild Helseth, Birger Mo, and Hans Olaf Hågenvik. “Nonconvex Environmental Constraints in Hydropower Scheduling”. In: *2020 International Conference on Probabilistic Methods Applied to Power Systems (PMAAPS)*. Aug. 2020, pp. 1–6.
- [32] Jiehong Kong, Hans Skjeltbred, and Olav Fosso. “An overview of formulations and optimization methods for the unit-based short-term hydro scheduling problem”. In: *Electric Power Systems Research* 178 (Sept. 2019).

- [33] A. Arce, T. Ohishi, and S. Soares. “Optimal dispatch of generating units of the Itaipu hydroelectric plant”. In: *IEEE Transactions on Power Systems* 17.1 (2002), pp. 154–158.
- [34] Skagerak Kraft. ”Kraftomsetning” Accessed 13. April 2022 from. <https://www.skagerakkraft.no/kraftomsetning/category1036.html>.
- [35] Olav Fosso and M.M. Belsnes. “Short-term Hydro Scheduling in a Liberalized Power System”. In: Nov. 2004.
- [36] Mohammed Albadi. *Computational Models in Engineering*. 1st ed. IntechOpen, 2020.
- [37] Hossein Farahmand. ”DC Power Flow in Power Markets” Accessed 22. April 2022 from. Blackboard notat. 2021.
- [38] K. Purchala et al. “Usefulness of DC power flow for active power flow analysis”. In: *IEEE Power Engineering Society General Meeting, 2005*. 2005, 454–459 Vol. 1.
- [39] D. Van Hertem et al. “Usefulness of DC power flow for active power flow analysis with flow controlling devices”. In: *The 8th IEE International Conference on AC and DC Power Transmission*. 2006, pp. 58–62.
- [40] Hossein Farahmand. ”Flow-Based Market Coupling” Accessed 24. April 2022 from. Blackboard notat. 2021.
- [41] NVE. ”NVE Atlas” Accessed 14. March 2022 from. <https://atlas.nve.no/Html5Viewer/index.html?viewer=nveatlas#>.
- [42] Statnett SF. ”Ofoten-Balsfjord” Accessed 22. April 2022 from. <https://www.statnett.no/vare-prosjekter/region-nord/ofoten-balsfjord/#om-prosjektet>.
- [43] Statnett SF. ”Vindkraft i Øst-Finnmark: Muligheter og konsekvenser” Accessed 2. May 2022 from. <https://www.statnett.no/globalassets/for-aktorer-i-kraftsystemet/planer-og-analyser/vedlegg---rapport-vindkraft-i-ost-finnmark.pdf>.
- [44] ”Pyomo” Accessed 27. May 2022 from. <http://www.pyomo.org/about>.
- [45] ”GLPK” Accessed 27. May 2022 from. <https://www.gnu.org/software/glpk/>.
- [46] NVE. ”Map” Accessed 11. March 2022 from. <https://sildre.nve.no/map?x=380400&y=7228000&zoom=4>.
- [47] NVE. ”Veileder i planlegging, bygging og drift av små kraftverk” Accessed 27. April 2022 from. [https://publikasjoner.nve.no/veileder/2010/veileder2010\\_01.pdf](https://publikasjoner.nve.no/veileder/2010/veileder2010_01.pdf).
- [48] Norges Bank. ”Valutakurser” Accessed 2. April 2022 from. <https://www.norges-bank.no/tema/Statistikk/Valutakurser/?tab=currency&id=EUR>.
- [49] E24. ”Strømprisene i sør holder seg høye: – Veldig lavt nivå i vannmagasinene” Accessed 19. May 2022 from. <https://e24.no/boers-og-finans/i/a79j1d/stroemprisene-i-sor-holder-seg-hoeye-veldig-lavt-nivaa-i-vannmagasinene>. 2022.
- [50] NVE. ”Magasinstatistikk” Accessed 8. April 2022 from. <https://www.nve.no/energi/analyser-og-statistikk/magasinstatistikk/>. 2022.
- [51] Wikipedia. ”Nord<sub>n</sub>orge” Accessed 4. April 2022 from. <https://no.wikipedia.org/wiki/Nord-Norge>.
- [52] NVE. ”Vannkraftdatabase” Accessed 2. April 2022 from. <https://www.nve.no/energi/energisystem/vannkraft/vannkraftdatabase/>.
- [53] Statnett SF. ”Kraftsystemet i Finnmark: Analyse av behov og tiltak etter 2020” Accessed 2. May 2022 from. <https://www.statnett.no/globalassets/for-aktorer-i-kraftsystemet/planer-og-analyser/kraftsystemet-i-finnmark.pdf>.



- 
- [54] M Haugen and A Helseth. "Primod – A fundamental short-term model for power system analyses and multi-market price forecasting" Accessed 10. May 2022 from. <https://sintef.brage.unit.no/sintef-xmlui/bitstream/handle/11250/2757351/2021-00376.pdf?sequence=2>. 2021.
- [55] SINTEF Energy. "New commands related to build unit PQ curves since SHOP 12" Accessed 27. May 2022 from. <https://www.sintef.no/contentassets/6b622776fc0f4bab9b5168d69ba93da1/getting-energy-conversion-right-pq-curves-jiehong.pdf>.
- [56] Statnett SF. "Verdien av regulerbar vannkraft: Betydning for kraftsystemet i dag og i fremtiden" Accessed 25. May 2022 from. <https://www.statnett.no/contentassets/b82dcf206acc4762b2abcc3182e5bc52/verdien-av-regulerbar-vannkraft-statnett-mars-2021.pdf>.
- [57] Andreas Bo et al. "The impact of Flow-Based Market Coupling on the Nordic region". In: Sept. 2020, pp. 1–6.
- [58] Statnett SF. "Prisforskjeller og kapasitet nord-sør" Accessed 2. April 2022 from. <https://www.statnett.no/contentassets/1d183d99f1d943e1bc67c5ef98887052/presentation-webinar-prisforskjeller-og-kapasitet-nord-sor.pdf>.
- [59] Statnett SF. "Analyse av transportkanaler 2021-2040" Accessed 18. May 2022 from. <https://www.statnett.no/globalassets/for-aktorer-i-kraftsystemet/planer-og-analyser/nup-2021/analyse-av-transportkanaler-2021-2040.pdf>.

## Appendix

### A Journal publication - EEM 2022

# The Influence on Day-Ahead Trading Volumes by Including Power Flow Equations in The Planning Algorithm for Short-Term Hydropower in Congested Areas

**Abstract**—This report investigates the influence of including power flow equations in the short-term hydro scheduling. Ensuring that the load obligation is covered at the lowest cost possible is a vital aspect to the power producers. As of today, the hydropower producers do not include the limits of the power system when planning for the day-ahead market is conducted. A DC approximation is used for the power flow, meaning the scheduled production might not be feasible for the given power system. Bottlenecks in the power system occur because of insufficient transfer capacity, leading to differences in power price within the system. By introducing power flow equations to the short-term hydro scheduling, the dynamics of the power system will be accounted for. Thus, the hydropower producers can utilize their capacity in a more precise manner, by making decisions with a deeper knowledge of when and where to produce. A quantitative case study using realistic data from hydropower plants and power grid in the price area NO4 is presented, which highlights the impact of the optimization model developed by the authors of this paper. The case study is conducted over a time period with 168 time steps (one week), introducing different restrictions in the case study to investigate the dynamics of the power system.

**Index Terms**—Short-Term Hydropower Scheduling (STHS), Multi-Period Optimal Power Flow (MPOPF), Day-Ahead Trading Volumes, Nodal prices, Optimization

## NOMENCLATURE

### Sets

- $\mathcal{K}$  Set of segments by linearizing PQ-curve, where  $\mathcal{K} \in \{1, 2, \dots, k\}$
- $\mathcal{N}$  Set of nodes in the system, where  $\mathcal{N} \in \{1, 2, \dots, 20\}$
- $\mathcal{S}$  Set of plants in the system, where  $\mathcal{S} \in \{1, 2, \dots, s\}$
- $\mathcal{T}$  Set of time steps of one hour, where  $\mathcal{T} \in \{1, 2, \dots, 168\}$

### Variables

- $\delta_i$  Phase angle at sending node  $i$ . [rad]
- $\delta_j$  Phase angle at receiving node  $j$ . [rad]
- $p_{t,ij}^G$  Power flow from node  $i$  to node  $j$  in time step  $t$ . [MW]
- $p_{t,n,k}$  Power production for linear segment  $k$ ,  $\{k \in \mathcal{K}\}$ , at node  $n$  in time step  $t$ . [MW]
- $p_{t,n}^D$  Power consumption at node  $n$  in time step  $t$ . [MW]
- $p_{t,n}^G$  Power production at node  $n$  in time step  $t$ . [MW]
- $q_{t,n,k}$  Discharge for linear segment  $k$ ,  $\{k \in \mathcal{K}\}$ , at node  $n$  in time step  $t$ . [ $m^3/s$ ]

- $q_{t,n}$  Discharge from the reservoir at node  $n$  in time step  $t$ . [ $m^3/s$ ]
- $s_{t,n}$  Spillage from the reservoir at node  $n$  in time step  $t$ . [ $m^3/s$ ]
- $v_{t,n}$  Reservoir level at node  $n$  at the end of time step  $t$ . [ $Mm^3$ ]

### Parameters

- $f$  Conversion factor between [ $m^3/s$ ] and [ $Mm^3/h$ ]. Time step of one hour gives  $f = 0.0036$ .
- $e_{n,k}$  Energy equivalent for linear segment  $k$ ,  $\{k \in \mathcal{K}\}$ , at node  $n$ , telling how much power one can get from each cubic meter of water through the turbine. [ $kWh/m^3$ ]
- $I_{t,n}$  Inflow at node  $n$  in time step  $t$ . [ $m^3/s$ ]
- $k_n$  Water value for reservoir at node  $n$ . [ $NOK/Mm^3$ ]
- $P_{t,ij}^{max}$  Maximum power flow in line from node  $i$  to node  $j$  in time step  $t$ . [MW]
- $Q_{t,n,k}^{max}$  Maximum discharge level for linear segment  $k$ ,  $\{k \in \mathcal{K}\}$ , at node  $n$  in time step  $t$ . [ $m^3/s$ ]
- $Q_{t,n}^{min}$  Minimum discharge level at node  $n$  in time step  $t$ . [ $m^3/s$ ]
- $V_{t,n}^{max}$  Maximum reservoir level at node  $n$  in time step  $t$ . [ $Mm^3$ ]
- $V_{t,n}^{min}$  Minimum reservoir level at node  $n$  in time step  $t$ . [ $Mm^3$ ]
- $x_{ij}$  Reactance on line from node  $i$  to node  $j$ . [ $\Omega$ ]

## I. INTRODUCTION

Bottlenecks occur when the transmission capacity from one part of the power system does not satisfy the demand for power flow out of the given area. This is a highly relevant problem that occurs between the northern and southern parts of Norway. Low prices in the northern part of Norway happens due to lower demand and high possible production in the area. In the fall of 2021 the area prices experienced great differences as the reservoir levels in Southern Norway were lower than usual [1]. As a result the water value increased drastically in those areas. The reason for these price differences is the way bottlenecks are handled in Norway. When bottlenecks occur, the power system will be divided into temporary markets, where supply and demand are met internally in the regions [2]. In October 2019 Statnett SF conducted an analysis to see how upgrading

different parts of the power grid would affect the socio-economic surplus. Statnett is a state-owned company that builds, operates and develops the Norwegian power system. The report concluded that even though power flows increases and price differences between regions decrease, there will still be differences. In addition a big portion of the direct market value of upgrading the capacity in the power grid would accrue foreign countries should the price differences in Norway decrease significantly [3]. Therefore, optimizing the utilization of the power grid and resources already present seems to be the most socio-economic solution.

In the daily operation of a hydropower plant, the utilization of the resources available is the most important challenge for the producer. Increasing penetration of new renewable energy sources increases the strain on the power system. In addition, it will contribute to bottlenecks and more frequent changes in the price differences between the Nordic price zones. The development of tools that explicitly take into account the network topology and its effect on the spot price is therefore an important issue. The operation of hydropower plants are well researched and documented in the literature. Previous studies have investigated this topic in a highly simplified manner, not taking into account the dynamics of a meshed network. In [4] and [5] a combination of hydropower and wind power were investigated, with an objective to include the high penetration of wind in the model, and thus utilize the existing grid better. Both articles analyze a radial system and only evaluate the flow out of the system, not taking into account the dynamics of a meshed network. Neglecting the dynamics could potentially lead to infeasible production planning, laying the basis for the area prices in the system. In this paper, the authors want an answer to whether including load flow equations in STHS will change the production pattern for the hydropower producers, and the aim is thus:

- Compare water disposition with and without grid restrictions in Short-Term Hydropower Scheduling
- Investigate whether it is possible for the hydro power producer to influence bottlenecks and thus achieve price coupling/disconnection between neighbouring areas through storage dynamics and dispatch decisions

## II. MODEL DESCRIPTION AND MATHEMATICAL FORMULATION

The case study in this report is conducted by using a linearized multi-period optimal power flow algorithm combined with short-term hydro scheduling.

The objective function for the optimization problem can then be formulated as:

### A. Objective function

$$\min \sum_{n \in \mathcal{N}} k_{t,n} \cdot (v_{1,n} - v_{t,n}), \quad \forall t \in t_{end} \quad (1)$$

The objective of the optimization problem is to minimize the value of the water used to cover the load obligation. This can be equivalent to maximizing the value of water in the

reservoir(s). The summation secures that the value of storing water in all reservoirs are included, and one cannot empty the reservoir in one period, often referred to as the water value function. This is the future value of water in the reservoir after the planning period, inherited from long-term hydropower scheduling which account for stochastic inflow and demand.

### B. Hydro constraints

The hydro constraints in a STHS problem secures the technical aspects from a hydropower producers perspective, where restrictions on discharge, reservoir level/balance and production are the most essential for implementation of such a model.

$$q_{t,n,k} \leq Q_{n,k}^{max}, \quad \forall t \in \mathcal{T}, \forall n \in \mathcal{N}, \forall k \in \mathcal{K} \quad (2)$$

$$\sum_{k \in \mathcal{K}} q_{t,n,k} - q_{t,n} = 0, \quad \forall t \in \mathcal{T}, \forall n \in \mathcal{N}, \forall k \in \mathcal{K} \quad (3)$$

$$v_{t,n} \leq V_{t,n}^{max}, \quad \forall t \in \mathcal{T}, \forall n \in \mathcal{N} \quad (4)$$

$$v_{t,n} \geq V_{t,n}^{min}, \quad \forall t \in \mathcal{T}, \forall n \in \mathcal{N} \quad (5)$$

$$v_{t,n} - v_{t-1,n} + f(q_{t,n} + s_{t,n} - I_{t,n}) = 0, \quad \forall t \in \mathcal{T}, \forall n \in \mathcal{N} \quad (6)$$

$$\sum_{k \in \mathcal{K}} q_{t,n,k} \cdot e_{n,k} - p_{t,n}^G = 0, \quad \forall t \in \mathcal{T}, \forall n \in \mathcal{N}, \forall k \in \mathcal{K} \quad (7)$$

Restriction 2 corresponds to the upper discharge bounds. Restriction 3 is the lower discharge bound, securing that the discharge is equal to the minimum discharge and discharge from the given segments. These constraints are important, together with restriction 7, to secure a convex relation between  $p$  and  $q$ . By allowing 0 as an operating point, the relation between  $p$  and  $q$  gets non-convex and cannot be solved linearly. Restriction 4 and 5 corresponds to the upper and lower reservoir bounds, keeping the reservoir between its maximum and minimum levels. Restriction 6 secures the reservoir balance in the system. The reservoir level in time step  $t$  is equal to the final reservoir in the previous time step  $t-1$  and any inflow to the system in time step  $t$ , subtracting any discharge and spillage in time step  $t$ . Restriction 7 gives the hydro production given any discharge through the turbine for the different segments. The last segment does not lead to any change in production, but represents spillage and bypass discharge. Together with restriction 2 and 3, the minimum level is used to secure a convex problem. In this model it was decided to allow 0 as an operating point, giving the optimization model the ability to shut down the production on the hydropower plants. The result of this is a less good approximation of the first segment in the PQ-curve.

### C. Power flow constraints

The power flow restrictions couples the hydropower production to the power flow in system, in addition to maintaining energy balance. A DC power flow is applied to the system, where the reactance of the tie-line between the buses determines the power flow.

$$\sum_{i \in \mathcal{N}} p_{t,i}^G - \sum_{i \in \mathcal{N}} p_{t,i}^D = 0, \quad \forall t \in \mathcal{T} \quad (8)$$

$$p_{t,ij} \leq P_{t,ij}^{max}, \quad \forall t \in \mathcal{T}, \forall i, j \in \mathcal{N} \setminus \{i = j\} \quad (9)$$

$$p_{t,i}^G - p_{t,i}^D = \sum_{j \neq i}^3 p_{t,ij}, \quad \forall t \in \mathcal{T}, \forall i \in \mathcal{N} \quad (10)$$

$$p_{t,ij} = \frac{1}{x_{ij}} (\delta_i - \delta_j), \quad \forall t \in \mathcal{T}, \forall i, j \in \mathcal{N} \setminus \{i = j\} \quad (11)$$

Restriction 8 secures the physical obligation for the producer, covering the demand in each hour. The capacity constraint on the line flow is presented in restriction 9. The real power balance in each node the system is secured by restriction 10. Nodal prices are retrieved as the dual variable from this restriction, reflecting the effect of one additional unit of power at the node. To accommodate the DC power flow the balance equation is presented in restriction 11.

## III. CASE STUDY

### A. Implementations

The case study in this paper is the northernmost price zone in the Norwegian power system, NO4. This area has been a region of interest and discussions due to the large surplus of power in the region compared to the capacity of the overlaying transmission grid. As seen in Figure 1 NO4 is an extensive zone which to a large degree contains a radial transmission grid. As a result of the surplus and radial grid the spot market price in the region more than often differs from the neighboring price zones, typically lower. The modelled price zone will provide analytical results allowing for a better understanding on how an extensive grid consisting of loads and hydropower plants will behave. The analysis is conducted for a period of one week where each hour represents a time step, similar to the day-ahead market. Thus, it will be of great interest to see how the production planning will be conducted given the variations in water value together with grid limitations in the system.

The case study consists of three simulation cases. Each case is designed with inspiration from real challenges encountered in the day to day operation of the Norwegian transmission system, starting from the base case which is similar to how STHS is conducted today and thus will provide a good starting point for comparison. The simulations are done for 168 time steps representing the first week in January with increments of one hour.

The following cases are considered:

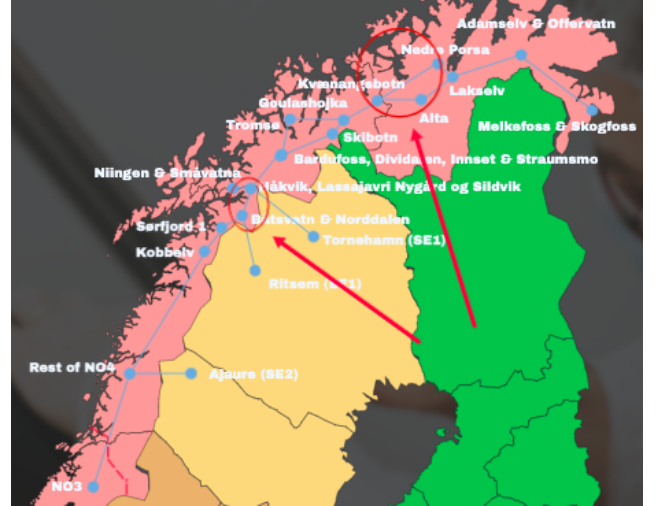

Fig. 1. Nodal representation of the northern part of NO4.

- 1) Base case: The base case is constructed to imitate how STHS is conducted today meaning the hydropower producers neglect the system topology and restrictions when production planning is conducted. The results from the simulation will serve as a reference point for the influence network characteristics and topology induce into the production planning.
- 2) Case 1 - Ofoten bottleneck (as shown as the southernmost red circle in Figure 1): Within NO4 there are certain passages that restricts the possibility to transport power from the northern part further south as the capacity of the transmission lines are not sufficient. Ofoten is one of the passages that has been widely discussed. In 2017 a new 420 kV transmission line was completed on the distance Ofoten-Balsfjord with the goal of erasing the bottleneck as well as increasing the power supply security [6]. Although the new transmission line dealt with some of the issues regarding capacity and security the region still experiences challenges with surplus of power with little possibilities of transportation out of the area. In this case a 40 MW capacity restriction on the line between Haakvik and Balsfjord is introduced.
- 3) Case 2 - East to west bottleneck in Finnmark (as shown as the northernmost red circle in Figure 1): The second case introduces a restriction in the northernmost part of NO4. The transmission system in Finnmark is a part of the Norwegian transmission system with low capacity. The lines in Finnmark are built in such a manner that they reach the maximum flow at approximately the same time, which is one of the main reasons Statnett consider it to not be beneficial to increase the capacity in the region. In this case a capacity limit on the line Nedre Porsa-Kvænangsbotn and Alta-Kvænangsbotn at 10 MW and 40 MW respectively are introduced.

## B. Results

*Base case:* The base case of the analysis consists of hydropower power plants and loads at the nodes as seen in Figure 1. There is no line restrictions on power flow between the nodes. The water value for the hydropower producing nodes are defined for the end period of the scheduling horizon.

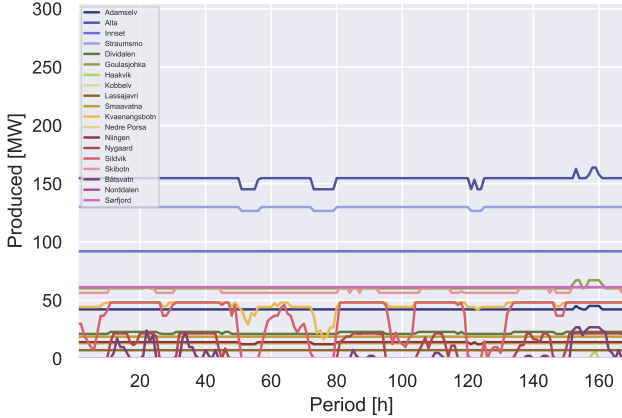

Fig. 2. Power produced at each hydropower plant with no capacity restrictions

The solution of the base case seen in Figure 2 is something to expect in a situation where no restrictions or topology is taken into account. The only aspect deciding which unit should produce is the value of the water used to produce the required amount of power. Therefore, the nodal prices in the system is the same implying a common system price in all periods of the analysis.

Looking at the producing units it is possible to observe how Norddalen does not produce in this case even though the water value at the affiliated reservoir is the lowest in the system. This is due to the fact that the efficiency of the power plant makes it less favorable to produce. This implies that you have to use a larger amount of water to produce the same amount of power compared to plants with higher water value, making it less economically favorable. On the other hand the plants covering the largest share of the load is Alta and Straumsmo, given the low water value of the affiliated reservoirs together with the efficiency of the plants. The variations seen in Figure 2 are expected fluctuations due to the varying demand in the region seen throughout the whole period.

*Case 1:* In this case the well-known bottleneck around Ofoten has been imitated where the power in the northern part of NO4 lacks the possibility of covering the demand south of Ofoten. The goal is to highlight and observe how the internal limitations and characteristics of NO4 creates an uncoupling within NO4 and initiates production at more expensive hydropower plants.

The power flow on the line between Haakvik and Båtsvatn is at max capacity throughout the whole period as expected. The location of the largest loads are in the southern part of NO4 while the cheapest production is located at nodes north

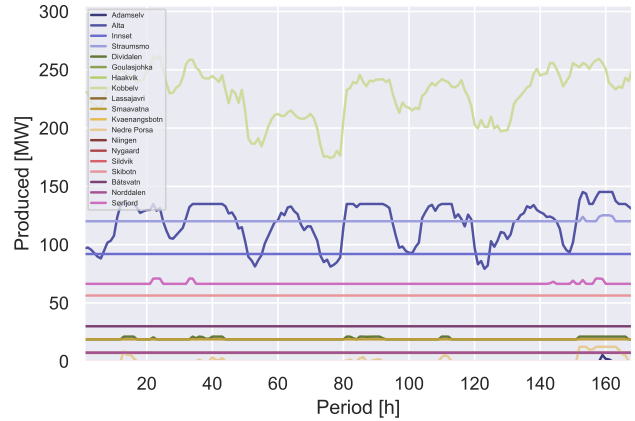

Fig. 3. Power produced at each hydropower plant with capacity restrictions between north and south in NO4

of the bottleneck at Ofoten, meaning the system will utilize the capacity of the restricted line at full extend. The rest of the system adjust after the flow in the restricted line is set, and the new production pattern can be seen in Figure 3.

The solution with the new restriction introduces an uncoupling between the northern and the southern part of NO4. The northern part has a surplus of cheaper power resulting in a lower nodal price for the nodes located in the region, while the southern part experiences the opposite with a higher nodal price. This can be seen in the changes in production pattern as Norddalen for instance is producing a constant amount throughout the period as the topology of the nearby grid together with the adjacent plants requires it to produce, contributing to the increase in nodal prices nearby. It is also notable how Kobbelv in this situation covers a large amount of the load even though it has the highest water value. This is a result of the radial grid surrounding the plant as the resistance in a radial system highly affects the location where production takes place, due to how power flow is generated.

*Case 2:* The last case highlights an issue surrounding the internal transmission capacity in Finnmark. To date concession for around 400 MW wind power in Finnmark has been issued [7]. The challenge is the location of the wind parks in question, the majority lies east in Finnmark where the transmission grid already face challenges with capacity. The goal in this case is to see how the restrictions present in the grid already causes price uncoupling within Finnmark, without the prospective wind parks.

The power flow on the line between Alta and Kvænangsbott is at max capacity throughout the whole period and therefore creates a bottleneck, while the power flow between Nedre porsa and Kvænangsbott balances around the limit occasionally creating a bottleneck. Similar tendencies are seen in this case compared to the base case. The system utilizes the capacity of the restricted lines almost at max for both lines throughout the period causing change in the production

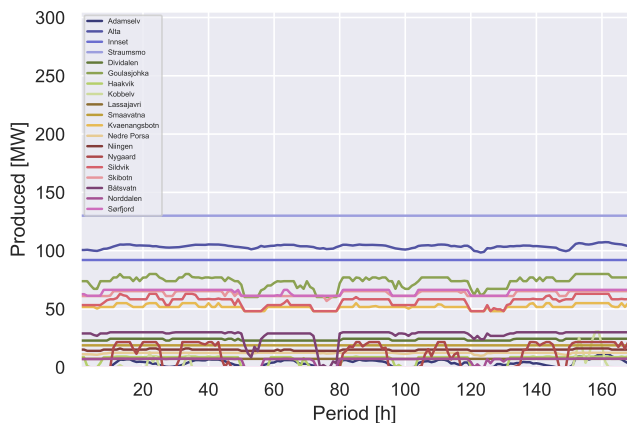

Fig. 4. Power produced at each hydropower plant with capacity restrictions between east and west in Finnmark

pattern highlighted in Figure 4.

Also in this case there will be an uncoupling around the area experiencing congestion within Finnmark. The eastern part has access to cheaper power resulting in lower nodal prices. This comes as a result of production in the region taking place at some of the cheaper plants in the system and due to the capacity of these power plants being below the production capacity. The hydropower plants in the uncoupled eastern area need to cover a decreased share of the total load giving the opportunity use less of the more expensive water. This can be seen in the production pattern of Adamselv who rarely covers any load in this case as other plants in the region such as Alta is cheaper and has capacity to cover much of the decreased load.

#### IV. CONCLUSION

This paper raises the question: 'In what way do the load flow equations affect STHS, and can this be implemented to make better decisions now and in the future?'

Today the power market is cleared by utilizing a two-stage algorithm, namely the day-ahead and intra-day market. The intra-day market is mainly to deal with internal congestion within the bidding zones. The results in this paper underscore the difference including power flow equations in STHS could mean for the participants in the market. They would be able to see where production should take place from an economical and a technical point of view. From the base case to Case 1 it was evident that less economic decisions had to be made when accounting for the power grid. Norddalen and Kobbelv ended up producing contrary to the results seen in the base case. This pattern can also be seen in Case 2 where the production on Adamselv decrease as Alta has access to cheaper power. These results imply that the current planning algorithm entails over- and underproduction. The tendencies seen in the results could also be of value in larger systems, accounting for the power exchange between bidding zones might facilitate for better utilization of the existing grid. In addition more precise

price signals could be obtained reflecting the actual cost of producing, seen in the nodal prices.

This approach to spot market clearance will be of great interest to TSOs and hydropower producers, where better utilization of the existing power grid leads to smarter decisions. This will reduce the need for re-dispatching and thus a decrease in the total costs.

Furthermore, the authors want to expand the power grid to analyze the impact this algorithm will have on the Nordic power market and neighbouring bidding zones. Volatile wind power production and the Intraday market are also of great interest to model in connection with this algorithm. Stochastic data on inflow and correct coupled water values from the long-term hydropower scheduling will contribute to more accurate analyzes.

#### ACKNOWLEDGMENT

We would like to thank our supervisor through good encouragement, great input and fruitful discussions throughout the work on this paper. In addition would we like to thank co-supervisor for valuable contributions. We must also thank for the contribution from The Norwegian Water Resources and Energy Directorate (NVE), SINTEF Energy and Statkraft. It would not have been possible to create this model without data on the hydropower plants and the power grid in NO4.

#### REFERENCES

- [1] Statnett SF, "Det eksepsjonelle kraftåret 2021," <https://www.statnett.no/om-statnett/nyheter-og-pressemeldinger/nyhetsarkiv-2022/det-eksepsjonelle-kraftaret-2021/>
- [2] L. R. Solberg, "Flaskehals i kraftmarkedet," <https://www.duo.uio.no/bitstream/handle/10852/17550/LARS-RAGNAR-SOLBERG14.11.08.pdf?sequence=1>
- [3] Statnett SF, "Analyse av transportkanaler," <https://www.statnett.no/globalassets/for-aktorer-i-kraftsystemet/planer-og-analyser/nup-og-ksu/analyse-av-transportkanaler-2019-2040.pdf>
- [4] J. Matevosyan, M. Olsson, and L. Söder, "Hydropower planning coordinated with wind power in areas with congestion problems for trading on the spot and the regulating market," in *Electric Power Systems Research*, vol. 79, nr. 1, pp. 39–48, 2009
- [5] V. Stensaker Stave, M. Fogstad Dyrge, H. Farahmand, M.Korpås, and Ü. Cali, "Optimal Utilisation of Grid Capacity for Connection of New Renewable Power Plants in Norway," in *2021 International Conference on Smart Energy Systems and Technologies (SEST)*, pp. 1–6, 2021
- [6] Statnett SF, "Ofoten-Balsfjord," <https://www.statnett.no/vare-prosjekter/region-nord/ofoten-balsfjord/>
- [7] Statnett SF, "Kraftsystemet i Finnmark: Analyse av behov og tiltak etter 2020," <https://www.statnett.no/globalassets/for-aktorer-i-kraftsystemet/planer-og-analyser/kraftsystemet-i-finnmark.pdf> <https://www.statnett.no/vare-prosjekter/region-nord/ofoten-balsfjord/>

