

IGF26 - 26th International Conference on Fracture and Structural Integrity

Thickness effect on the mechanical behavior of PLA specimens fabricated via Fused Deposition Modeling

Zhuo Xu^a, Rakel Fostervold^a, Seyed Mohammad Javad Razavi^{a*}

^a*Department of Mechanical and Industrial Engineering, Norwegian University of Science and Technology, Richard Birkeland vei 2B, 7491, Trondheim, Norway*

Abstract

The mechanical properties of components produced with additive manufacturing are known to be dependent on the geometry and the thickness of the fabricated part. The geometry of the components can have a direct influence on the distribution of internal porosities, surface quality, geometrical accuracy, residual stresses in the AM fabricated parts, resulting in variation of the mechanical properties with the input geometry. Therefore, it is vital to understand the link between the mechanical behavior of these components and their geometry and thickness to improve the design technique and applicability of the manufacturing technique. In this study, the influence of the thickness of PLA (Polylactic Acid) specimens fabricated via Fused Deposition Modeling (FDM) technology on their mechanical properties has been investigated. A total number of 20 test specimens were manufactured via FDM technique layer-by-layer with four different thicknesses including 1mm, 3mm, 5mm, and 10mm, where the thickness of 3mm is the value suggested in ASTM standard for tensile testing of polymers. Mechanical properties such as Poisson's ratio, Young's modulus, ultimate tensile stress, yield stress, and elongation at failure were analyzed and determined from uniaxial tensile tests. In order to evaluate the full-field displacement and strains on the surface of specimens, 2D digital image correlation (DIC) analyses were performed on the tested specimens. Furthermore, the fracture surface of the tested specimens was analyzed using optical microscopy to evaluate the building thickness on the governing failure mechanisms. The experimental results revealed that specimens with higher building thickness experience both higher ultimate tensile strength and elongation at failure. Furthermore, the experimental results illustrate the tendency of lower variations of elongation at failure when the thickness increases because of less influence of uneven temperature distribution on the building plate.

* Corresponding author.

E-mail address: javad.razavi@ntnu.no

© 2021 The Authors. Published by Elsevier B.V.

This is an open access article under the CC BY-NC-ND license (<https://creativecommons.org/licenses/by-nc-nd/4.0>)

Peer-review under responsibility of the scientific committee of the IGF ExCo

Keywords: Fused deposition modeling (FDM); Thickness effect; Mechanical properties; PLA; Additive manufacturing; Tensile tests

1. Introduction

Additive manufacturing (AM) is a broad terminology that refers to a variety of technologies that fabricate components from a virtual 3D CAD model (Wu et al. 2020),(Wang et al. 2017),(Daminabo et al. 2020)(Seibert et al. 2020). It is a technology for the fabrication of personal and industrial components which has been developed over the last decade. Additive manufacturing technologies provide major benefits, including a high degree of design freedom, customized products, low material waste, and the ability to manufacture small batches at a lower cost. Unlike several traditional manufacturing methods such as milling and CNC machining, which manufacture parts by eliminating unnecessary material from bulk material, AM begins from nothing and fabricates the components in a layer-by-layer sequence. It provides design flexibility and enables the manufacture of previously inaccessible geometries such as structurally optimized, integrated, and functionally components with nearly no material waste (Ivanova, Williams, and Campbell 2013),(González-Henríquez, Sarabia-Vallejos, and Rodríguez-Hernandez 2019).

Fused deposition modeling (FDM) or fused filament fabrication (FFF) is one of the most widely used 3D printing technologies for thermoplastic due to its cost-effectiveness and simplicity in manufacturing industrial components with complex geometries in the automotive, aerospace, and medical fields (Peng et al. 2020). It is a fabrication method where the filament is heated and extruded through a nozzle, then deposited onto a building platform. Then the building platform will move down with the height of one layer so that the next layer will be printed when the previous layer is completed. Composite materials and printing process parameters optimization of the FDM technology were investigated and reviewed by Mohan et al (Mohan et al. 2017). Thermoplastic materials such as PLA, ABS, PETG, TPU, and Nylon as well as some fiber-reinforced composites are widely adopted in FDM printers.

Numerous experiments have been performed on how parameters can influence the mechanical properties of FDM fabricated specimens, such as printing speed (Žarko et al. 2017), extrusion & building platform temperature (Choi et al. 2016), infill types and density (Pandzic, Hodzic, and Milovanovic 2019), and raster angles (Gebisa and Lemu 2019). Although some researchers have attempted to investigate the thickness effect of conventionally manufactured polymers such as reinforced thermoplastics (Pechulis and Vautour 1998), glass hybrid fiber composites (Sandyal, Sreenath, and Sandyal 2019), short fiber-reinforced resin composite (Medikasari, Herda, and Irawan 2018), carbon fiber-graphite (M. N. Ahmed et al. 2013), and additive manufactured titanium alloy (Razavi, Van Hooreweder, and Berto 2020). However, there is a lack of research on the thickness influence of mechanical properties for FDM fabricated specimens.

Nomenclature

AM	additive manufacturing
CAD	computer-aided design
CNC	computer numerical control
DIC	digital image correlation
FDM	fused deposition modeling
FFF	fused filament fabrication
PLA	polylactic acid
UTS	ultimate tensile strength

2. Experimental Procedures

2.1. Materials and fabrication process

The specimens were fabricated via FDM technique by using an Original Prusa i3 MK3 with a filament diameter of 1.75mm. The working principle is illustrated in Fig. 1. Transparent PLA filament produced by 3DNet was selected as a feedstock due to the fact that colors are reported to affect the mechanical properties of 3D printed PLA (Wittbrodt and Pearce 2015). G-codes were generated by the slicing software Ultimaker Cura 4.8.0. All the specimens were fabricated with 100% infill density in order to approach as closely as the optimal mechanical properties of fully dense material (Torres et al. 2016). In addition, the infill line directions (raster angles) were determined to be ± 45 degrees for alternative layers. All detailed important parameters were demonstrated in Table 1. These parameters were determined based on the experimental results, in which the aim was to fabricate a decent specimen with as few voids as possible while maintaining accurate dimensions and smooth layers. Cross-sectional area and initial gauge length for each thickness are listed in Table 2.

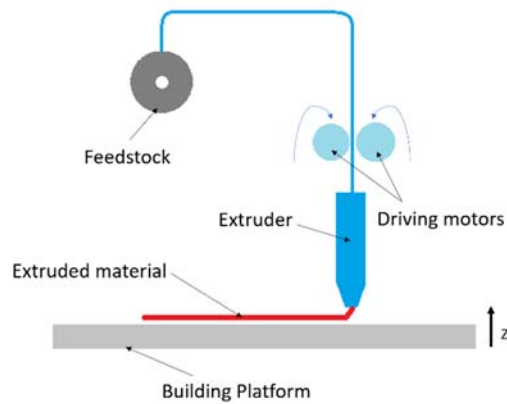

Fig. 1. Schematic illustration of FDM process.

Table 1: Process parameters used for fabricating the specimens.

Building parameters	Parameter value	Building parameters	Parameter value
Layer height	0.1mm	Build plate temperature	75 °C
Infill line distance	0.4mm	Printing speed	45mm/s
Wall thickness	0.8mm	Initial layer printing speed	30mm/s
Wall line count	2	Nozzle diameter	0.4mm
Infill density	100%	Nozzle temperature	215 °C

Table 2: Cross-section and initial gauge length for each thickness

Property: thickness	I-1mm	I-3mm	I-5mm	I-10mm
A_0 [mm ²]	13	39	65	130
L_0 [mm]	57	57	57	57

2.2. Tensile tests

Four different geometries of testing specimens with a thickness of 1mm, 3mm, 5mm, and 10mm were fabricated where the thickness of 3mm is the value recommended in ASTM standard for tensile testing of polymers (Fig. 2). Five specimens were fabricated all at once with a parallel printing sequence for each case as illustrated in Fig. 3. The fabricated specimens were then tested under a displacement rate of 2mm/min until failure as reported in (A. A. Ahmed and Susmel 2018). The actual thickness for each specimen was measured with a caliper before testing in order to obtain more accurate computation results of stress. This operation demonstrated a certain level of manufacturing variability concerning the nominal size.

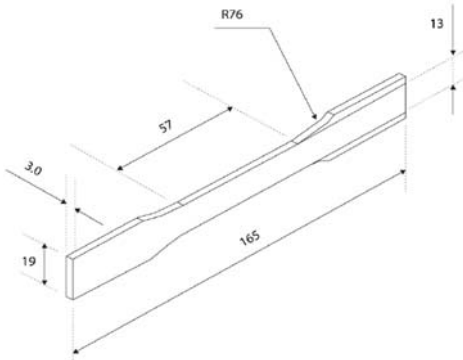

Fig. 2. Standard dimensions of test specimen ASTM D638 type

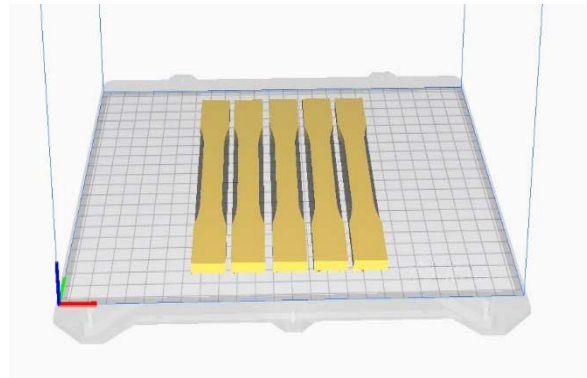

Fig. 3. Specimens printing orientations on a building platform

The tensile tests were performed with Digital Image Correlation (DIC). It is an optical method for accurate 2D or 3D measurements of full-field displacement and strains during mechanical testing. A fixed camera system was used to capture frames with a predefined sampling frequency. In addition, a dedicated software called VIC 2D to subsequently analyze and track changes in images through cross-correlation algorithms (Caporossi, Mazzanti, and Bozzano 2018). In this experiment, specimens were painted white and speckled with black dots in order to make a distinct contrast. The software tracked the movement of the speckles in the X and Y direction and calculated the corresponding strains. A schematic illustration showed in Fig. 4 demonstrated the movement of the dots and the corresponding increase in length. The sampling frequency was set to be 200ms (capturing 5 images per second). Furthermore, Hirox RH-2000 digital microscope was also used to examine the fracture surfaces of the specimens. The pictures were taken from the side of the specimens as well as the fracture surfaces.

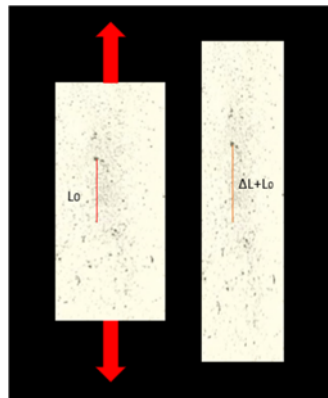

Fig. 4. A schematic illustration of DIC principles

3. Results and Discussions

The purpose of these tensile tests is to investigate the thickness effect of the mechanical properties. Three out of five specimens were selected as representative specimens to study the failure patterns as demonstrated in Fig. 5. It is noticeable that the majority of the fracture location occurred within the edge of the gauge portion of the specimens. One of the reasons could attribute to the printer settings. The Cura slicing software started each new layer at the intersection between the gripping area and the gauge portion as illustrated in Fig. 6. The printing continues in the direction as the red arrow indicates. Lastly, the gripping area on the other side and the gauge part in the middle start to print. As a result, this printing sequence could lead to a potential weak spot in the specimens, because of temperature differences and adhesion between the strands.

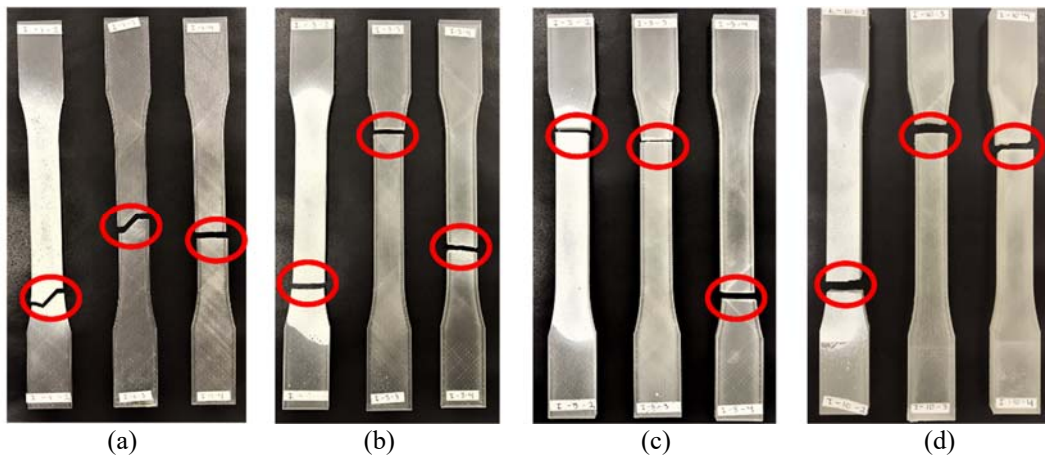

Fig. 5. Specimens after fracture with different thickness: (a) 1mm, (b) 3mm, (c) 5mm, (d) 10mm

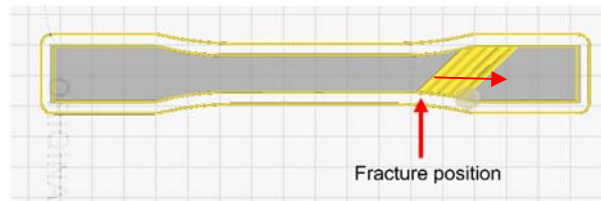

Fig. 6. Printing procedure of each layer during 3D printing

Stress-strain curves for various thicknesses were obtained as shown in Fig. 7. In addition, the average value of yield strength, ultimate tensile strength, Young's modulus, Poisson's ratio, and elongation at failure are calculated and listed in Table 3, accompanied by the standard deviation for relevant values. DIC was also used to obtain the full-field strain distributions of the specimens as illustrated in Fig. 8. It can be discovered that specimens with larger building thickness experience both higher ultimate tensile strength (UTS) and larger elongation at failure. One of the reasons is the first layer influence. The printer speed was set to be 30mm/s for the first layer, which was relatively smaller than the printing speed (45mm/s) for the rest of the layers in order to have a stronger adhesion between the layer and the building platform. Therefore, the actual thickness of the first layer is slightly higher than the rest (0.1mm) even though the thickness of all the layers are pre-defined as the same value in the G-code.

According to the experimental results reported by (Yao et al. 2019), ultimate tensile stress decreases with ± 45 degree raster angles when layer thickness increases from 0.1mm to 0.3mm. Therefore, UTS for 0.15mm layer thickness is slightly lower than that of 0.1mm layer thickness. Consequently, the first layer quality will have less influence when the thickness is larger since it is less dominant. Another reason is that a higher number of layers can

result in a higher temperature gradient in layers, which can lead to an acceleration of the diffusion process between adjacent rasters, lowering the void ratio and increasing the bond's strength (Garzon-Hernandez et al. 2020).

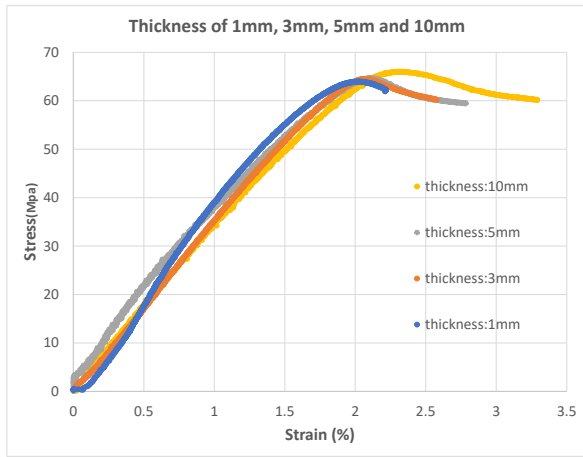

Fig. 7. Representative stress-strain curves for each thickness

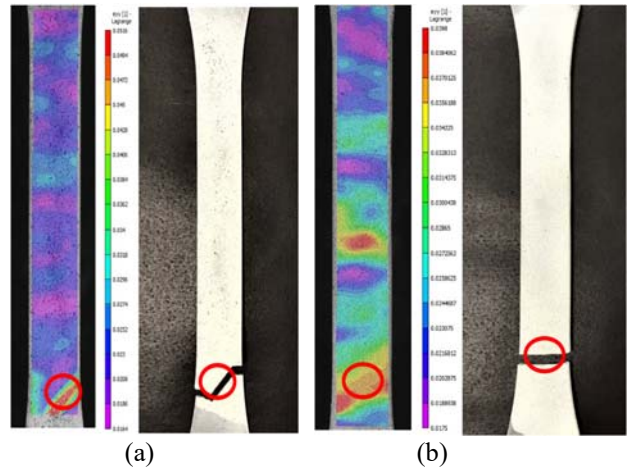

Fig. 8. Strain in Y-direction of DIC compared with tensile tests of thickness: (a) 1mm, (b) 3mm

Table 3: Calculated values of yield stress, ultimate tensile strength (UTS), Young's modulus, Poisson's ratio, and elongation at break for various thicknesses.

Property	Thickness: 1mm	Thickness: 3mm	Thickness: 5mm	Thickness: 10mm
Yield stress [Mpa]	60±0.93	63±0.59	63±1.08	61±0.44
UTS [Mpa]	63.97±1.74	64.50±0.62	64.65±0.26	66.00±0.61
E [Gpa]	3.2	3.1	3.1	2.8
Poisson's ratio	0.275	0.316	0.342	0.378
%EL	2.21±0.36	2.58±0.31	2.78±0.30	3.29±0.26

4. Conclusions

Thickness influences of PLA specimens fabricated via FDM technology on their mechanical properties have been investigated in this study. Tensile tests were performed under uniaxial static loading, and DIC was used to calculate the strains of the specimens. After the tensile tests, the specimens were investigated under an optical microscope and discovered to have a high density with few voids.

The experimental results indicated that there is a high degree of association between tensile properties and thickness. Specifically, specimens with larger building thickness experience both higher ultimate tensile strength and larger elongation at failure. One of the reasons is the influence of the first layer quality. Another reason is attributed to the fact that a higher temperature gradient in the layers can result in improvement of the bonding between layers. In addition, it can be observed that Young's modulus is slightly decreased with an increase in thickness of the specimens, which indicates the stiffness of the specimens decreases when thickness increases. Furthermore, the standard deviation of mechanical properties (yield stress, ultimate tensile strength, and elongation at failure) has a tendency to decrease when thickness increases due to a possible reason that lower influence of uneven temperature distributions on the building platform.

5. References

- Ahmed, A. A., and L. Susmel. 2018. “A Material Length Scale–Based Methodology to Assess Static Strength of Notched Additively Manufactured Polylactide (PLA).” *Fatigue and Fracture of Engineering Materials and Structures* 41(10): 2071–98.
- Ahmed, M Nayeem, P Vijaya Kumar, H K Shivanand, and Syed Basith Muzammil. 2013. “A Study on Effect of Variation of Thickness on Tensile Properties of Hybrid Polymer Composites (Glass Fibre-Carbon Fibre- Graphite) and GFRP Composites.” *International Journal of Engineering Research and Applications* 3(4): 2015–24.
- Caporossi, Paolo, Paolo Mazzanti, and Francesca Bozzano. 2018. “Digital Image Correlation (DIC) Analysis of the 3 December 2013 Montescaglioso Landslide (Basilicata, Southern Italy): Results from a Multi-Dataset Investigation.” *ISPRS International Journal of Geo-Information* 7(9).
- Choi, Young-Hyu, Cheol-Min Kim, Hwan-Seock Jeong, and Jeong-Ho Youn. 2016. “Influence of Bed Temperature on Heat Shrinkage Shape Error in FDM Additive Manufacturing of the ABS-Engineering Plastic.” *World Journal of Engineering and Technology* 04(03): 186–92.
- Daminabo, S. C. et al. 2020. “Fused Deposition Modeling-Based Additive Manufacturing (3D Printing): Techniques for Polymer Material Systems.” *Materials Today Chemistry* 16: 100248. <https://doi.org/10.1016/j.mtchem.2020.100248>.
- Garzon-Hernandez, S., D. Garcia-Gonzalez, A. Jérusalem, and A. Arias. 2020. “Design of FDM 3D Printed Polymers: An Experimental-Modelling Methodology for the Prediction of Mechanical Properties.” *Materials and Design* 188: 108414. <https://doi.org/10.1016/j.matdes.2019.108414>.
- Gebisa, Aboma Wagari, and Hirpa G. Lemu. 2019. “Influence of 3D Printing FDM Process Parameters on Tensile Property of Ultem 9085.” *Procedia Manufacturing* 30: 331–38. <https://doi.org/10.1016/j.promfg.2019.02.047>.
- González-Henríquez, Carmen M., Mauricio A. Sarabia-Vallejos, and Juan Rodríguez-Hernández. 2019. “Polymers for Additive Manufacturing and 4D-Printing: Materials, Methodologies, and Biomedical Applications.” *Progress in Polymer Science* 94: 57–116. <https://doi.org/10.1016/j.progpolymsci.2019.03.001>.
- Ivanova, Olga, Christopher Williams, and Thomas Campbell. 2013. “Additive Manufacturing (AM) and Nanotechnology: Promises and Challenges.” *Rapid Prototyping Journal* 19(5): 353–64.
- Medikasari, M., E. Herda, and B. Irawan. 2018. “Effect of Resin Thickness and Light-Curing Distance on the Diametral Tensile Strength of Short Fibre-Reinforced Resin Composite.” *Journal of Physics: Conference Series* 1073(5).
- Mohan, N., P. Senthil, S. Vinodh, and N. Jayanth. 2017. “A Review on Composite Materials and Process Parameters Optimisation for the Fused Deposition Modelling Process.” *Virtual and Physical Prototyping* 12(1): 47–59. <https://doi.org/10.1080/17452759.2016.1274490>.
- Pandzic, Adi, Damir Hodzic, and Aleksa Milovanovic. 2019. “Effect of Infill Type and Density on Tensile Properties of Pla Material for Fdm Process.” *Annals of DAAAM and Proceedings of the International DAAAM Symposium* 30(1): 545–54.
- Pechulis, Michael, and Daniel Vautour. 1998. “The Effect of Thickness on the Tensile and Impact Properties of Reinforced Thermoplastics.” *Journal of Reinforced Plastics and Composites* 17(17): 1580–86.
- Peng, Xingshuang et al. 2020. “Investigation of Processing Parameters on Tensile Performance for FDM-Printed Carbon Fiber Reinforced Polyamide 6 Composites.” *Composites Communications* 22(September): 100478. <https://doi.org/10.1016/j.coco.2020.100478>.
- Razavi, S. M.J., B. Van Hooreweder, and F. Berto. 2020. “Effect of Build Thickness and Geometry on Quasi-Static and Fatigue Behavior of Ti-6Al-4V Produced by Electron Beam Melting.” *Additive Manufacturing* 36(June): 101426. <https://doi.org/10.1016/j.addma.2020.101426>.
- Sandyal, Prajwal, N Sreenath, and Adarsh Sandyal. 2019. “Effect of Strain Rate and Thickness on Mechanical Properties of Jute / Glass Hybrid Fiber Composites.” : 269–75.
- Seibert, Paul et al. 2020. “Validation of the Averaged Strain Energy Density Criterion for Additively Manufactured Notched Polylactide Acid Specimens.” *Procedia Structural Integrity* 28: 2099–2103.
- Torres, Jonathan et al. 2016. “An Approach for Mechanical Property Optimization of Fused Deposition Modeling with Polylactic Acid via Design of Experiments.” *Rapid Prototyping Journal* 22(2): 387–404.
- Wang, Xin et al. 2017. “3D Printing of Polymer Matrix Composites: A Review and Prospective.” *Composites Part B: Engineering* 110: 442–58. <http://dx.doi.org/10.1016/j.compositesb.2016.11.034>.
- Wittbrodt, Ben, and Joshua M. Pearce. 2015. “The Effects of PLA Color on Material Properties of 3-D Printed Components.” *Additive Manufacturing* 8: 110–16. <http://dx.doi.org/10.1016/j.addma.2015.09.006>.
- Wu, H. et al. 2020. “Recent Developments in Polymers/Polymer Nanocomposites for Additive Manufacturing.” *Progress in Materials Science* 111(November 2019).
- Yao, Tianyun, Zichen Deng, Kai Zhang, and Shiman Li. 2019. “A Method to Predict the Ultimate Tensile Strength of 3D Printing Polylactic Acid (PLA) Materials with Different Printing Orientations.” *Composites Part B: Engineering* 163(December 2018): 393–402. <https://doi.org/10.1016/j.compositesb.2019.01.025>.
- Žarko, Jelena, Gojko Vlačić, Magdolna Pál, and Sandra Dedijer. 2017. “Influence of Printing Speed on Production of Embossing Tools Using FDM 3d Printing Technology.” *Journal of Graphic Engineering and Design* 8(1): 19–27.