

# Liquid Air Energy Storage – Analysis and Prospects

## Abstract

Energy supply is an essential factor for a country's development and economic growth. Nowadays, our energy system is still dominated by fossil fuels that produce greenhouse gases. Thus, it is necessary to switch to renewable energy forms and increase efforts in waste-to-energy systems. However, once renewable energy sources are introduced in the industrial system, the most important considerations are the stability and sustainability of the energy supply because of the intermittency of renewable energy. Based on the previous considerations, storage technologies for electrical energy are discussed in this chapter to compensate for this problem. A few mature technologies are introduced, such as pumped hydroelectric energy storage (PHES), compressed air energy storage (CAES), hydrogen electrolysis and fuel cells (FC), and batteries. However, they have not been widely applied due to some limitations such as geographical constraints, high capital costs and low system efficiencies. Liquid air energy storage (LAES), has the potential to overcome the drawbacks of the previous technologies and can integrate well with the existing components and power systems. In this chapter, the principle of LAES is analyzed and four LAES technologies with different liquefaction processes are compared. Four evaluation parameters are used: round-trip efficiency, specific energy consumption, liquid yield, and exergy efficiency. The results indicate that LAES with hot and cold energy storage has considerable advantages over the other processes. Finally, the future prospects of a hybrid system with higher system efficiency and performance, where LAES is integrated with renewable energy, waste heat and batteries are discussed.

**Keywords:** Energy supply, Renewable energy, Energy storage technologies, Liquid air energy storage

## 1 Introduction

The security of the energy supply has always been a core item on the European political agenda. In 2006, it was listed as one of the cornerstones of the common energy policy, alongside with environmental objectives and economic competitiveness [1].

Currently, we mainly depend on the fossil-based economy. More than 80% of the energy consumption comes from (traditional) fossil fuels, which drives our economy and supports the industrial, transportation and buildings sectors in our society. However, there is a threat from climate change caused by emissions from fossil fuels, which means that we need to take actions [2]. One measure is to switch our energy focus from traditional non-renewable energy structures to renewable energy forms, and also increase efforts in waste-to-energy systems.

With the development of the technologies, renewable energy and power sources are getting cheaper and competitive with existing ones (coal, oil, gas, and nuclear). Once installed, these power sources have limited operational costs. This has led to a growing share of renewable energy sources. If the process industries are to become more energy-efficient and sustainable, industrial energy systems need to integrate different energy sources such as renewable and waste-to-energy systems. However, it is essential to consider one important barrier for the switch, which is the intermittent nature of renewable energy sources. This means that renewable power might hold limited potential to substitute fossil fuels, due to the requirement of stability in a sustainable energy market.

An interesting trend for industrial systems that is likely to be realized in the next decades, is the use of distributed energy systems that are adopted in a systematic and holistic way. A distributed energy system is an efficient, reliable and environmentally friendly alternative to the traditional energy system. With the system, energy conversion units are situated close to energy consumers, and large units are substituted by smaller ones [3]. The advantages of utilizing distributed systems are mainly based on flexibility, locality, and networking. The flexibility of distributed energy systems is associated with their scalability and ability to utilize various energy conversion technologies and energy sources. An improvement can be seen also in the reliability of energy supply because of the tendency of distributed systems to reduce the vulnerability of the overall system. This is related to their ability to operate in networks and utilize local resources. In addition, distributed energy systems are environmentally friendly because of the absence of large power plants and transmission lines [4].

Following the trends of the energy system means that renewable energy is used as a kind of energy source in the distributed energy system, and it seems to be the most promising future energy system. However, once renewable energy is introduced to industrial systems, the most important consideration should be the stability and sustainability of the energy supply because of the intermittency of renewable energy sources. Therefore, it is necessary to adopt energy storage technologies to smoothen variations in supply and demand and guarantee supply during energy deficit periods.

There are many energy storage technologies already reviewed in the literature [5-7]. These technologies are currently at different levels of maturity with a few already proven for commercial scale applications. These technologies can be broadly classified according to the purpose for which the energy is stored, and they include both thermal and electrical energy storage.

### **1.1 Thermal Energy Storage (TES)**

TES is one of the most widely used forms of energy storage. The TES principle is the same for all technologies: energy is supplied during off-peak periods, it is collected and stored in the form of heat (specific, latent or reaction heat), and later in peak periods it is transferred for use. According to the actual application, these processes may occur simultaneously or more than once in the storage cycle. There are three thermal energy storage methods, and these will be briefly described in the following.

#### **Sensible Heat Energy Storage (SHES)**

In this form, the energy storage is based on the specific heat of the material, which means the material does not undergo any form of phase change within the temperature range required for the storage application [8]. The most common materials for high temperature TES include concrete, cast ceramics, and molten salts. Molten salts with high storing temperature have been applied in solar thermal technology, their main disadvantages are that most of them have high melting points and parasitic heating is required to keep them in liquid phase, which can lead to additional energy consumption.

## Latent Heat Energy Storage (LHES)

In this case, the energy is stored during phase change of the material. Such materials have a high potential for thermal energy storage compared to the non-phase changing counterparts due to the high latent heat associated with the phase change. For energy storage applications, the phase of the material changes (usually from solid to liquid) at a temperature matching the thermal input source [9].

## Thermochemical Energy Storage (TCES)

This technology stores heat via reversible reactions. During off-peak periods, surplus thermal energy is used to dissociate a chemical reactant into products in a reaction which is endothermic. The products are stored separately pending periods when energy is needed. When energy is demanded, the stored products are mixed and will react to form the initial reactant in a reaction which is exothermic [10].

Table 1.1 shows typical characteristics for different thermal energy storage technologies, which can give guidance to the choice of the proper TES technology. The efficiency  $\eta$  for different technologies can be calculated as follows [11]:

$$\eta = \frac{\text{energy recovered}}{\text{energy input} + \text{initial energy in storage}} \quad (1)$$

However, the choice depends mainly on operating temperature range, storage capacity and duration required.

**Table 1.1** Typical characteristics for some thermal energy storage technologies [12]

Characteristics	SHES	LHES	TCES
Capacity [kWh/ton]	10 - 50	50 - 150	120 - 250
Thermal power [MW]	0.001 - 10	0.001 - 1	0.01 - 1
Efficiency [%]	50 - 90	75 - 90	75 - 100
Temperature range [°C]	30 - 100 (water)	40 - 120	80 - 1000
Storage duration	Day/month	Hour/month	Hour/day
Barriers	Low capacity (per weight/volume/power?)	High cost Material stability	High cost Complexity

## 1.2 Electrical Energy Storage (EES)

Electrical energy storage is regarded as one of the most readily available forms of storing energy. Electricity in its form cannot be stored (except in superconductors at cold temperatures). The only way to store electricity is to convert it into a more stable energy form, which would be transformed back to electricity when needed. There are various technologies that can be used to convert electricity to other forms of energy that can easily be stored. These technologies

are referred to as electrical energy storage technologies and can be grouped as follows: (i) mechanical energy storage, (ii) chemical energy storage, (iii) electrochemical energy storage (supercapacitors, electrolysis/FC, or batteries), (iv) superconducting magnetic energy storage, and (v) thermal energy storage [6]. In this section, not all EES technologies will be presented, only some mature technologies will be listed, including pumped hydroelectric energy storage (PHES, which belongs to mechanical energy storage), battery energy storage (which belongs to electrochemical energy storage), and compressed air energy storage (CAES, which belongs to thermo-mechanical energy storage). Last, but not least, liquid air energy storage (LAES) will be introduced.

### Pumped Hydroelectric Energy Storage (PHES)

PHES is the most mature and widely used large scale energy storage technology. Figure 1.1 shows the process of a PHES system that uses gravity to store energy. It stores electrical energy by pumping the water to a higher reservoir during off-peak periods when the energy is available. During peak periods, the water flows down to a lower reservoir, through a turbine where electricity is produced by a generator. The efficiency of the system is in the range of 65–85%. One limitation of the PHES is that several natural geological features are needed, and this is typically measured by a performance parameter that is defined as the adequate nearby land area divided by the adequate elevation [13].

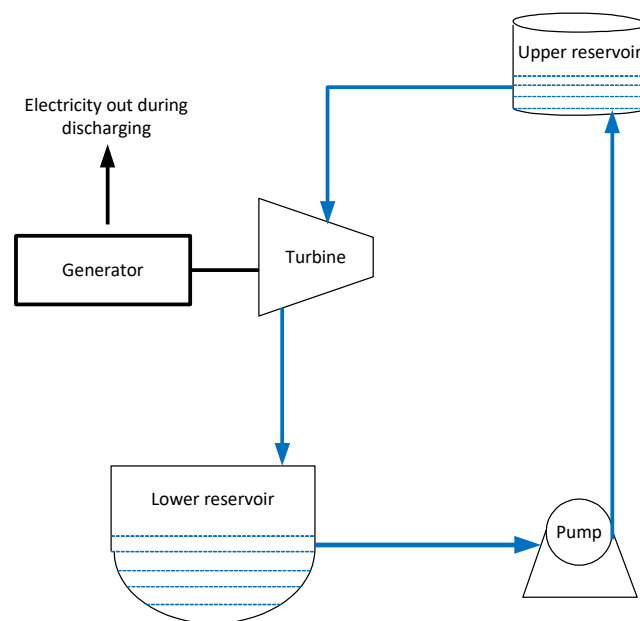

**Figure 1.1** Schematic of PHES system [14]

### Battery Energy storage

Battery system technology is the most widespread energy storage device for power system applications, at least in terms of number of devices (cellular phones, tablets, computers, etc). The electricity is stored as chemical energy in a battery. It is an electrochemical device with the ability to deliver energy by converting chemical energy into electricity through electrochemical reactions. The round trip energy storage efficiency is in the range of 60–95% depending on the operational cycle and the electrochemistry. Batteries have short life cycles (compared to PHES), however, they have a moderate to decent efficiency and are quite cheap

when the storage demand is small [13]. Sodium sulphur (NaS) battery is one of the batteries used for commercial electrical energy storage in distribution grids for electric utility. Its potential comes from its ability to provide high energy density (100-240 Wh/kg), good energy efficiency (>85%) and long discharge period (approximately 7 h) [6]. Lead acid (PbO<sub>2</sub>) battery is the oldest rechargeable battery for both commercial and household applications. It has a rated voltage of 2 V, energy density and power density of about 30 Wh/kg and 150 W/kg, respectively. Its energy efficiency ranges from 85% to 90% with low maintenance and investment costs. Lithium ion (Li-ion) battery is used in a wide range of applications, such as portable electronics, medical devices, transportations and grid supports. Their energy and power density range from 90 to 190 Wh/kg and 500 to 2000 W/kg. They also have a high efficiency range from 90-94% and moderate discharge time (about 2-4 h) [6].

### Compressed Air Energy Storage (CAES)

CAES systems use off-peak electricity to compress air and store it in a reservoir, either an underground cavern or above ground in pipes or vessels [15]. The air is released during peak periods, heated, expanded and used in a turbine and generator to produce electricity, as illustrated in Figure 1.2. The CAES has an estimated efficiency in the range of 46-70% depending on the battery limit for the system, with an expected lifetime of about 40 years. The drawback of CAES is that it is geographically constrained, because the compressed air is preferably kept in underground caverns, otherwise high pressure tanks must be used to store the air above ground.

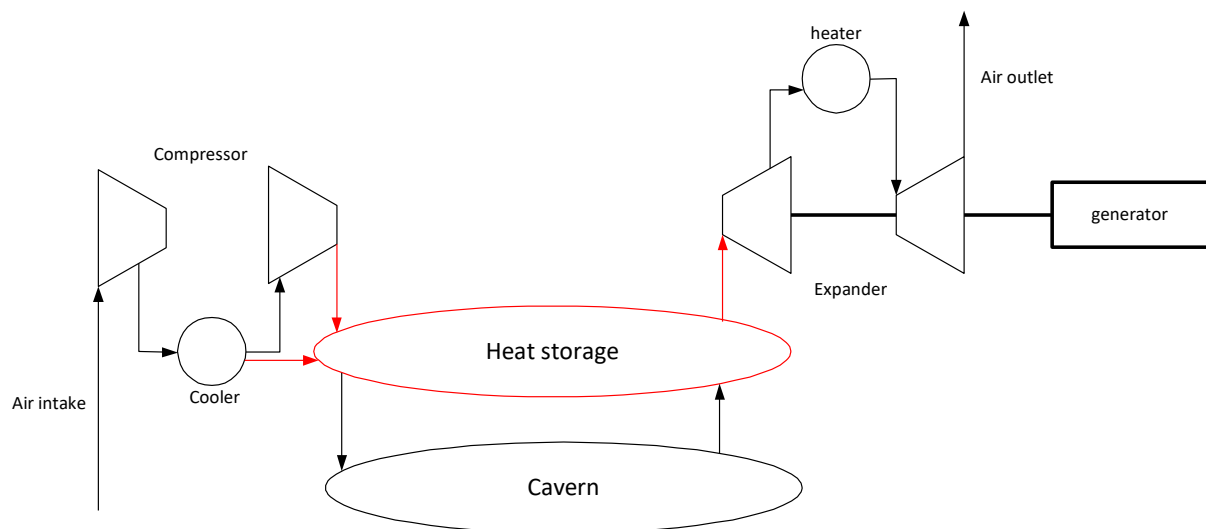

**Figure 1.2** Schematic of an adiabatic CAES system [15]

The three aforementioned technologies (PHES, BES, and CAES) have been available for decades, but have still not been widely applied because of the limitations of the technologies, such as geographical constraints, high capital costs and low system efficiencies. Due to these reasons, efficient, economical, and in particular geographically unconstrained electrical energy storage technologies have the promise to be utilized in future energy systems. Among the proposals, liquid air energy storage (LAES) seems a technology that suits better.

## Liquid Air Energy Storage (LAES)

LAES has the advantage that this technology can be improved by using ideas from established technologies, such as gas liquefaction processes and air separation. The most important reason is that it is not geographically constrained, like *e.g.* PHES. LAES consists of three distinct processes: charging, storing and discharging. During charging, excess electricity (*e.g.* from wind turbines) can drive an air liquefaction process. Air from the environment is compressed in stages and then expanded to ambient pressure and sub-ambient temperature to generate the necessary refrigeration capacity to liquefy air. Liquid air is then stored in cryogenic tanks at nearly ambient pressure. During discharge, liquid air is pumped to high pressure, then regasified and expanded through turbomachines to generate electricity and thereby recover the stored energy.

The charging process, which in essence is a liquefaction process, has direct influences on the liquid yield, and in turn the round-trip efficiency (which is mentioned in Section 3). Thus, the liquefaction process is the crucial step in LAES processes. Four LAES technologies with different liquefaction processes are described and compared in this chapter, and a hybrid arrangement with higher system efficiency and performance is mentioned in Section 4.

## 2 LAES technologies

### 2.1 Simulation of the process concepts

The simulation of four LAES technologies with different liquefaction processes were carried out using Aspen HYSYS. These processes are Linde-Hampson, Claude, Kapitza and a modified Claude process. The design parameters for the simulations are given in Table 2.1.

### 2.2 Linde-Hampson process

The simplest approach to liquefy air was proposed by Linde, and the cycle was patented in 1903 [16]. The Linde-Hampson process for liquefying air is shown in Figure 2.1 (a). First, the air enters the compressor and is compressed to high pressure. Then the air goes through a cooler and a heat exchanger to be further cooled down. The air receives cryogenic energy from the recirculating vapor from the separator. The Joule-Thompson (J-T) valve expands the air to ambient pressure to complete the liquefaction process. The result is a mixture of gas and liquid that is sent to a separator. After the separator, the storing and discharging processes follow, which are the same for the four LAES technologies.

### 2.3 Claude process

The idea of the Claude process [17], which is shown in Figure 2.1 (b), came from the Linde-Hampson process. The compression part in the Claude process is the same as the Linde-Hampson process. The difference occurs after the first heat exchanger, where the stream is split into two branches. One branch passes through the next two heat exchangers, and is then expanded in a J-T valve to generate a gas and liquid mixture, which is subsequently phase separated. The other branch goes directly to an expander to produce electricity, while expanding to ambient pressure. Then the expanded branch is mixed with the recirculating vapor to act as a cold stream to cool down the main incoming air.

## 2.4 Kapitza process

The Kapitza process is distinguished from the Claude process in that the third heat exchanger is removed [18], as shown in Figure 2.1 (c). The recirculating vapor from the separator is mixed directly with the expanded branch.

## 2.5 Modified Claude process

The modified Claude process with hot and cold thermal energy storage has a different layout than the previous processes, as shown in Figure 2.2. The ambient air is first compressed in a two-stage compressor to reach a high pressure. The high pressure air passes through two heat exchangers to obtain the cold energy from intermediate fluids, which are methanol and propane from the cold energy storage sector. Then the air enters a cryoturbine to expand to ambient pressure, which results in a gas and liquid mixture that is sent to a separator. For the process, both heat of compression and cold thermal energy (cooling) from regasification are stored in hot oil and methanol or propane, respectively. In this way, hot and cold thermal energy can be recycled to improve the efficiency of the overall system [19].

**Table 2.1** Design parameters for the processes

Parameter	Liquefaction process			
	Linde-Hampson	Claude	Kapitza	Modified Claude
Ambient temperature (°C)	25	25	25	25
Ambient pressure (kPa)	100	100	100	100
Pressure after compressor (kPa)	20,000	6,000	6,000	18,000
Pressure after pump (kPa)	6,500	6,500	6,500	6,500
Liquid air storage pressure (kPa)	100	100	100	100
Liquid air storage temperature (°C)	-194.3	-194.3	-194.3	-194.3
Propane minimum temperature (K)	-	-	-	-180
Propane maximum temperature (K)	-	-	-	-59
Methanol minimum temperature (K)	-	-	-	-59
Methanol maximum temperature (K)	-	-	-	15
Minimum approach temperature in cold box HX (K)	5	5	5	5
Minimum approach temperature in intercoolers (K)	-	-	-	10
Heat exchanger relative pressure loss	0	0	0	0
Isentropic efficiency of air turbines (%)	85	85	85	85
Isentropic efficiency of air compressors (%)	85	85	85	85
Isentropic efficiency of cryoturbine (%)	70	70	70	70
Recirculation ratio (%)	-	80	80	-

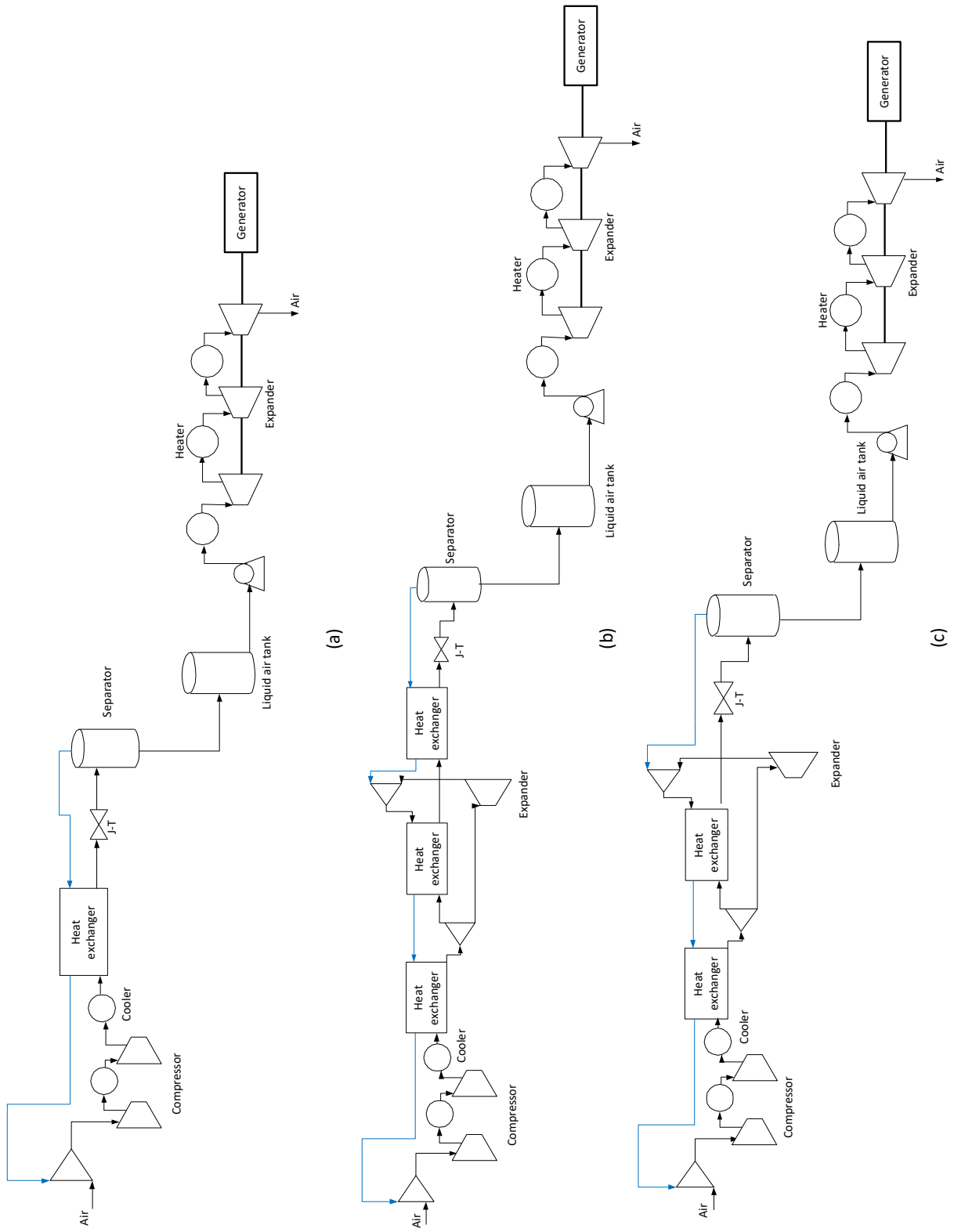

**Figure 2.1** (a) Linde-Hampson process; (b) Claude process; (c) Kapitza process



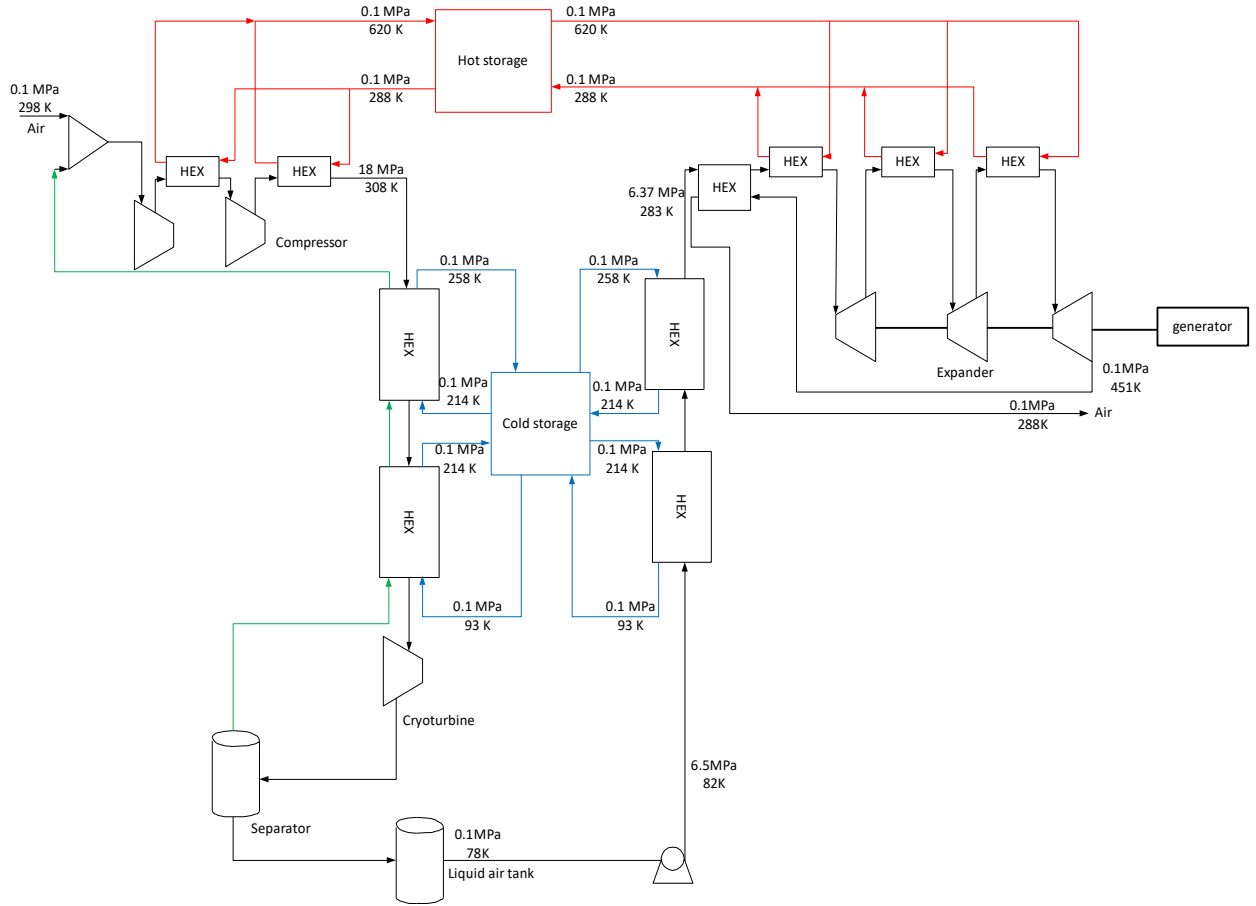

Figure 2.2 Modified Claude process with hot and cold thermal energy storage

### 3 Results and discussion

In order to evaluate the performance of the different processes, a few parameters were selected: liquid yield, round-trip efficiency, specific energy consumption, and exergy efficiency.

Liquid yield  $\eta_{LA}$  is defined as the ratio of the mass flow rate of liquid air ( $m_{liq}$ ) and the total mass flow rate of compressed air ( $m_{comp}$ ):

$$\eta_{LA} = \frac{m_{liq}}{m_{comp}} \quad (2)$$

The most important parameter is certainly the round-trip efficiency  $\eta_{RT}$  that is defined as the work output ( $W_{out}$ ) in recovery mode divided by the work input ( $W_{in}$ ) in storage mode:

$$\eta_{RT} = \frac{W_{out}}{W_{in}} = \frac{m_{liq} w_T}{m_{comp} w_C} = \eta_{LA} \cdot \frac{w_T}{w_C} \quad (3)$$

where  $w_T$  and  $w_C$  represent the specific work [kJ/kg] of the expanders and the compressors, respectively.

Another parameter for specific energy consumption ( $SEC$ ) is the net work consumed per hourly liquid air produced:

$$SEC = \frac{W_{net}}{m_{liq}} \quad (4)$$

where  $W_{net}$  is calculated as follows:

$$W_{net} = \sum W_{comp} - \sum W_{exp} \quad (5)$$

where  $W_{comp}$  and  $W_{exp}$  are the work [kJ] of the compressors and expanders respectively.

Finally, exergy efficiency could also be considered for comparing different processes. There are a number of approaches to calculate exergy efficiency, such as input-output exergy efficiency [20], consumed-produced exergy efficiency [21], and exergy transfer effectiveness [22]. A reasonable method to evaluate exergy efficiency for sub-ambient processes, such as the liquid air energy storage system, is the exergy transfer effectiveness (ETE). The ETE is defined by using a classification of exergy sinks (produced exergy) and exergy sources (consumed exergy). As the name suggests, the ETE can reveal the exergy transfer within a process. In the LAES, there are three sub-processes: charging, storage, and discharging, and it would be valuable to determine the exergy losses for the storage process (both the charging and storing process) and the discharging process. This information could be used to evaluate different sections of the system, and further directions for improvement could be pointed out based on the results of the analysis. The formula for exergy efficiency is given by the definition of the ETE:

$$ETE = \frac{\sum Exergy\ Sinks}{\sum Exergy\ Sources} \quad (6)$$

Marmolejo-Correa and Gundersen [22] proposed the ETE considering thermo-mechanical exergy and decomposed it into temperature-based and pressure-based exergy, which quantify the exergy contributions from the temperature and pressure levels of the streams. The ETE even included shaft work as exergy sink or source depending on production or consumption. The thermo-mechanical exergy  $E^{TM}$ , temperature-based exergy  $E^T$ , and pressure-based exergy  $E^P$  are calculated by Equations (7)-(10). Temperature-based exergy  $E^T$  can be further classified into above ambient, across ambient and below ambient, since the exergy content of heat cannot be estimated in the same way, as shown by Equation (11). Kim and Gundersen [23] further extended the ETE method to include the chemical exergy related to chemical reactions and compositional changes. Therefore, ETE is suitable for low temperature processes, and in particular provides accurate estimation for the case when the operating temperatures of the process range from below ambient to above ambient. The terms involved in the exergy sinks and sources of different LAES processes are listed in Table 2.2. It is assumed that the heat provided to the heaters in the three typical processes (Linde-Hampson, Claude and Kapitza) comes from a source with constant temperature 360 °C.

$$E^{TM} = H(T, p) - H(T_0, p_0) - T_0 [S(T, p) - S(T_0, p_0)] \quad (7)$$

$$E^{TM} = E^T + E^P \quad (8)$$

$$E^T = H(T, p) - H(T_0, p) - T_0 [S(T, p) - S(T_0, p)] \quad (9)$$

$$E^p = H(T_0, p) - H(T_0, p_0) - T_0 [S(T_0, p) - S(T_0, p_0)] \quad (10)$$

$$E[Q(T)] = Q \left[ 1 - \frac{T_0}{T} \right] \quad T \geq T_0$$

$$E[Q(T)] = Q \left[ \frac{T_0}{T} - 1 \right] \quad T \leq T_0 \quad (11)$$

where  $H$ ,  $S$ ,  $Q$ ,  $T$  and  $p$  are enthalpy [kJ/s], entropy [kJ/(kg °C)], heat [kJ/s], temperature [K], and pressure [Pa] of the streams, respectively;  $T_0$  and  $p_0$  are ambient temperature and pressure (25 °C and 1 bar), respectively;  $E[Q(T)]$  is the exergy content of heat [kJ/kg]. In Table 2.2, subscripts liq, hot, cold and heater represent the liquid air, hot oil, cold fluids (methanol and propane) and heaters in the processes.

**Table 2.2** The terms for calculating ETE of different LAES processes

LAES processes	Charging and storage process		Discharging process	
	Exergy sinks	Exergy sources	Exergy sinks	Exergy sources
Linde-Hampson	$E_{liq}$	$w_c$	$w_t$	$E_{liq} + E[Q(T)]_{heater}$
Claude	$E_{liq}$	$w_c$	$w_t$	$E_{liq} + E[Q(T)]_{heater}$
Kapitza	$E_{liq}$	$w_c$	$w_t$	$E_{liq} + E[Q(T)]_{heater}$
Modified Claude	$E_{liq} + E[Q(T)]_{hot}$	$w_c + E[Q(T)]_{cold}$	$w_t + E[Q(T)]_{cold}$	$E_{liq} + E[Q(T)]_{hot}$

Table 2.3 lists the liquid yield, specific energy consumption, exergy efficiency and round-trip efficiency for three typical liquefaction processes and the modified Claude process with hot and cold energy storage. The storage and discharging sections of the four processes are the same, the only difference is the liquefaction section for each process. The comparison of the four processes in Table 2.2 shows that the modified Claude process has advantages in terms of liquid yield, specific energy consumption, exergy efficiency and round-trip efficiency. In fact, without considering investment cost, this process is superior compared to the Claude process and the Kapitza process. This is due to the fact that the modified Claude process has a relatively small recirculation ratio as well as the use of hot and cold thermal energy storage in the process. The Linde-Hampson process has the lowest score for all performance indicators except exergy efficiency for discharging.

**Table 2.3** Performance parameters for liquid air energy storage processes

Performance	Linde-Hampson	Claude	Kapitza	Modified Claude	
Liquid yield (%)	7.32	16.58	16.13	85.34	
Specific energy consumption (kWh/kg)	3.83	0.81	0.81	0.12	
Exergy efficiency (%)	Charging and storage	5.1	21.12	21.16	84.12
	Discharging	38.64	38.64	38.64	78.31
Round-trip efficiency (%)	4.29	15.01	15.04	55.43	

## 4 Future prospects

Thanks to its unique features, LAES overcomes the drawbacks of PHES and CAES. It is not geographically constrained, it uses commercially available equipment (thus reduced upfront costs), and it integrates well with traditional power plants. Therefore, a LAES system can probably be considered as a viable option for grid-scale (hundreds of MWh) electric energy storage, even in stand-alone configuration. Until now, the biggest application scale for LAES is a small pilot with 5 MW storage capacity, which was built by Highview Power Plant in the UK [24]. The round-trip efficiency of the process was around 0.6. Li et al. [25] integrated the LAES with nuclear power plant (NPP) and the round-trip efficiency was claimed to reach 0.7. An approach with liquid air Rankine cycle was proposed by Ameer et al. [26] and the round-trip efficiency of 0.43 could be achieved. A standalone LAES plant was simulated by Guizzi et al. [19] reaching the round-trip efficiency of 0.55. All the present studies discussed have not been applied in large scale. Thus, LAES first needs further research to increase overall efficiency, store hot and cold thermal energy efficiently, and increase response time, and then the technology implemented in practical applications should be considered.

The future applications of LAES systems will be to integrate renewable energy, waste heat and batteries to form a hybrid system [27]. The hybrid plant concept integrating high speed drives for compressor and expander connections together with a small electrochemical storage makes these systems a promising solution, even when fast dynamic response is required. This feature, together with a high round-trip efficiency, are becoming essential performance requirements to manage a power system where the amount of renewable energy sources is rapidly growing, and where the number of power generating units able to offer control services is decreasing. Therefore, hybrid power plants based on LAES technology may be a promising solution to store energy and use it at peak times with satisfactory performance.

## References

- [1] Blyth W, Lefevre N. Energy security and climate change policy interactions: an assessment framework. International Energy Agency (IEA). Paris, France, 2004.
- [2] Burheim OS. Engineering energy storage: Academic Press, 2017.
- [3] Kara M, Hirvonen R, Mattila L, Viinikainen S, Tuhkanen S. Energy visions 2030 for Finland: Edita, 2001.
- [4] Alanne K, Saari A. Distributed energy generation and sustainable development. *Renewable Sustainable Energy Reviews*. 2006;10(6):539-58.
- [5] Arteconi A, Hewitt NJ, Polonara F. State of the art of thermal storage for demand-side management. *Applied Energy*. 2012;93:371-89.
- [6] Aneke M, Wang M. Energy storage technologies and real life applications—A state of the art review. *Applied Energy*. 2016;179:350-77.
- [7] Dunn B, Kamath H, Tarascon J-M. Electrical energy storage for the grid: a battery of choices. *Science*. 2011;334(6058):928-35.
- [8] Fernandez A, Martínez M, Segarra M, Martorell I, Cabeza L. Selection of materials with potential in sensible thermal energy storage. *Solar Energy Materials Solar Cells*. 2010;94(10):1723-9.
- [9] Chen H, Cong TN, Yang W, Tan C, Li Y, Ding Y. Progress in electrical energy storage system: A critical review. *Progress in Natural Science*. 2009;19(3):291-312.
- [10] Pardo P, Deydier A, Anxionnaz-Minvielle Z, Rougé S, Cabassud M, Cognet P. A review on high temperature thermochemical heat energy storage. *Renewable Sustainable Energy Reviews*. 2014;32:591-610.
- [11] Rosen MA. Appropriate Thermodynamic Performance Measures for Closed Systems for Thermal Energy Storage. *Journal of Solar Energy Engineering*. 1992;114(2):100-5.
- [12] Liew PY, Theo WL, Wan Alwi SR, Lim JS, Abdul Manan Z, Klemeš JJ, et al. Total Site Heat Integration planning and design for industrial, urban and renewable systems. *Renewable and Sustainable Energy Reviews*. 2017;68:964-85.
- [13] Ibrahim H, Ilinca A, Perron J. Energy storage systems—Characteristics and comparisons. *Renewable Sustainable Energy Reviews*. 2008;12(5):1221-50.
- [14] Rehman S, Al-Hadhrani LM, Alam MM. Pumped hydro energy storage system: A technological review. *Renewable and Sustainable Energy Reviews*. 2015;44:586-98.
- [15] Bullough C, Gatzen C, Jakiel C, Koller M, Nowi A, Zunft S. Advanced adiabatic compressed air energy storage for the integration of wind energy. Conference Advanced adiabatic compressed air energy storage for the integration of wind energy. London, UK 2004.
- [16] Linde C. Process of producing low temperatures, the liquefaction of gases, and the separation of the constituents of gaseous mixtures. US Patents 727650; 1903.
- [17] Claude G. Process for separation of the constituents of gaseous mixtures. US Patents 607775; 1913.
- [18] Kapitza PL. Method and means for distillation of low boiling point liquids. US Patents 625107; 1946.
- [19] Guizzi GL, Manno M, Tolomei LM, Vitali RM. Thermodynamic analysis of a liquid air energy storage system. *Energy*. 2015;93:1639-47.
- [20] Lior N, Zhang N. Energy, exergy, and second law performance criteria. *Energy*. 2007;32(4):281-96.
- [21] Kotas TJ. The exergy method of thermal plant analysis: Exergon Publishing Company with Paragon Publishing, 2012.
- [22] Marmolejo-Correa D, Gundersen T. A new efficiency parameter for exergy analysis in low temperature processes. *International Journal of Exergy*. 2015;17(2):135-70.
- [23] Kim D, Gundersen T. Development and use of exergy efficiency for complex cryogenic processes. *Energy conversion and management*. 2018;171:890-902.
- [24] Highview Power Storage official site <<http://www.highview-power.com>> [last accessed 04.06.19].
- [25] Li Y, Cao H, Wang S, Jin Y, Li D, Wang X, et al. Load shifting of nuclear power plants using cryogenic energy storage technology. *Applied Energy*. 2014;113:1710-6.

[26] Ameel B, T'Joel C, De Kerpel K, De Jaeger P, Huisseune H, Van Belleghem M, et al. Thermodynamic analysis of energy storage with a liquid air Rankine cycle. *Applied Thermal Engineering*. 2013;52(1):130–40.

[27] Antonelli M, Barsali S, Desideri U, Giglioli R, Paganucci F, Pasini G. Liquid air energy storage: Potential and challenges of hybrid power plants. *Applied Energy*. 2017;194:522-9.