

Marta Magán Domínguez

Evaluation of automating the material handling system in a Confectionery Factory

Master's thesis in Global Manufacturing Management

Supervisor: Fabio Sgarbossa

July 2020



Evaluation of automating the material handling system in a Confectionery Factory.

Marta Magán Domínguez

Supervisor: Fabio Sgarbossa

Co- Supervisor Spain: M^a Cristina De Stefano

Co-Supervisor: Giuseppe Fragapane

Master Thesis 2020 – NTNU

Trabajo Fin de Master 2020 – ETSII - UPM

Acknowledgment

This Master Thesis has been possible thanks to the NTNU which provides the sources necessary for the development of the thesis, including the visit to the Company.

Moreover, the support offered by my supervisor Fabio Sgarbossa has been a great guidance for facing the Thesis and push me to give a better performance.

Finally, I would like to appreciate the collaboration of Brynild Company for share their ideas, thoughts and experience to write this Master Thesis.

INTRODUCCIÓN

Desde principios del siglo XXI, se ha producido una creciente transformación tecnológica en la que la automatización robótica está tomando un papel importante. Una de las razones de esta escala de uso de los robots es la necesidad de las industrias de modernizarse y aumentar sus capacidades de producción (Y. Fernando, 2016). En particular, los sistemas de robots móviles constituyen un área de investigación creciente gracias a los beneficios que aportan como el aumento de la eficiencia o la reducción de los costes (N. Naidoo, 2019).

Paralelamente, la industria alimentaria se ha ido desarrollando durante este periodo impulsada por las nuevas exigencias del mercado y de los clientes (F. Jovane, 2003). Para satisfacer esta nueva demanda, esta industria ha evolucionado hacia una mayor capacidad de respuesta y una producción más eficiente (A. Romsdal, 2014). En este escenario tecnológico, pues, la industria alimentaria se ha actualizado.

El primer enfoque de la robotización en la industria alimentaria tuvo lugar en la década de los ochenta y se centró en el papel de los robots en el paletizado, la manipulación de materiales y el envasado terciario. Sin embargo, hace unos años y debido al gran crecimiento de la automatización, la tendencia actual ha cambiado hacia operaciones robóticas que incluyen procesos como el corte en rodajas (Y. Fernando, 2016). Desde entonces, las ventas de robots industriales para procesar alimentos aumentaron un 19% (F. Bader, 2018).

Los robots pueden ser implementados en casi todas las áreas dentro de una instalación de la industria alimentaria. Sin embargo, los avances tecnológicos en la industria alimentaria se centran mayoritariamente en los robots de procesamiento y menos en el transporte interno de materiales (D.G. Caldwell, 2013). En consecuencia, estos últimos presentan diseños básicos y escasa gama de aplicaciones.

A diferencia que en la industria alimentaria, la logística interna es un campo de investigación relativamente maduro en el que se han aplicado ampliamente muchas tecnologías, incluida la robótica autónoma (J. Wan, 2018). Esto ha permitido realizar investigaciones acerca de la aplicación de robots móviles autónomos como solución de sistema logístico interno tiene un gran impacto en la productividad y eficiencia de la empresa en donde se implementan, por ejemplo, sus aplicaciones en el sistema de intralogística de un hospital (S. Jeon, 2017) o en una empresa manufacturera (B. S. Kumar, 2018). Asimismo, algunos autores sugieren en sus investigaciones el uso de robots como sistema de manipulación de materiales para obtener un mejor rendimiento en sus resultados (H. Ardiny, 2015) (J.A. Estefanía, 2013) (A. Vale, 2014).

En este escenario, se encuentra la Compañía X, uno de los mayores fabricantes familiares de confitería de Noruega. A pesar de su alto nivel de automatización y robotización en todas las operaciones de procesamiento y envasado, el sistema de manipulación de materiales tiene una baja implementación de automatización y la mayoría de las transferencias de material se realizan manualmente. La empresa está buscando nuevas soluciones que puedan mejorar su servicio, eficiencia y productividad a la vez que disminuir sus gastos incurridos al aumentar su nivel de tecnología.

PREGUNTAS DE INVESTIGACIÓN

El presente documento, por tanto, estudiará la posibilidad de implementar una solución móvil autónoma (AGV o AMR) como sistema de manejo de material en el área de azúcar en las instalaciones de la compañía. El objetivo es evaluar los escenarios de la empresa X y diseñar una solución adecuada para ella teniendo en cuenta factores como la inversión necesaria para la mejora de la eficiencia/productividad o la sostenibilidad.

Se pretende, así pues, responder a las siguientes preguntas planteadas a priori:

PI.1: ¿Cuál es la tecnología adecuada para automatizar el sistema de logística interna en una instalación de la industria alimentaria cuya distribución en planta ya está fijo?

PI.2: ¿Cuál es la mejor solución para automatizar el sistema de manejo de materiales en la Compañía X?

METODOLOGÍA

El proyecto se respalda en dos revisiones sistemáticas de la bibliografía y la realización de simulaciones, como técnica cuantitativa, para analizar el caso específico de una empresa de confitería noruega

RESULTADOS DE LA REVISIÓN BIBLIOGRÁFICA

A fin de responder la primera pregunta de investigación planteada, se llevan a cabo dos revisiones bibliográficas. Se ha escogido esta metodología debido a la gran cantidad de investigaciones ya realizadas en el campo de robots móviles automáticos.

La primera revisión gira entorno a la viabilidad y los beneficios de un mayor grado de autonomía y tecnología en la logística interna de la industria alimentaria. Para llevar a cabo este estudio, se usó la plataforma científica Scopus, filtrando los artículos por las palabras claves: autonomous, mobile, robots, material handling, y escogiendo sólo aquellos artículos publicados entre el 2010-2020.

De esta búsqueda se obtuvieron 17 artículos, los cuales fueron clasificados por tipo de industria, tecnología usada, tipo de método de navegación, la razón para su implementación, beneficios y limitaciones. Aunque ninguno de los artículos se centra en la industria alimentaria, la mayoría de ellos muestran alternativas tecnológicas aplicables a cualquier industria. Además, las alternativas propuestas se centran en Automated Guided Vehicles (AGVs) o Autonomous Mobile Robots (AMR). Ambas soluciones se consideran acertadas para obtener mejores resultados dentro de la empresa. No obstante, resaltan más la opción de AMR debido a la flexibilidad que ofrece al poder pensar por sí mismo. Muchos autores subrayan, de hecho, que el AMR es la versión mejorada del AGV y el futuro está en seguir mejorando sus principales características: autonomía y flexibilidad. Asimismo, la información recogida en las demás categorías está alineados con este concepto. El resumen de beneficios y limitaciones de las oportunidades tecnológicas se recoge en las siguientes tablas:

Beneficios:

Automated	Autonomous
Flexibility	More Flexibility
--	No need of facility/infrastructure modification
Stop for avoiding collisions	Deal with dynamic environments. It can recalculate the routes, avoid obstacles
Promote safety	Promote safety
Increase productivity rate, efficient and efficiency	Increase productivity rate, efficient and efficiency
Reduce cost (labor)	Reduce cost (labor)
Availability for several shifts	Availability for several shifts

Limitaciones:

Automated	Autonomous
Need supervision of operators	--
Need to be customized for the implementation (design, dimensions, protocol interaction with the system,...)	Need to be customized for the implementation (design, dimensions, protocol interaction with the system,...)
Fixed path, no option to alterate it	Complex programming to find alternative paths, avoid obstacles, find the shortest distance
Need of facility/infrastructure modification	--
Need time for battery recharging	Need time for battery recharging
Planning and coordination routes for multiple robots	Planning and coordination routes for multiple robots
--	Investment

Tras esta primera parte del proyecto, se concluye que la industria alimentaria tiene oportunidad de mejora en el campo de la logística interna. Basándose en las experiencias de otras industrias, los robots móviles son una buena alternativa para mejorar este campo. Dentro de las dos alternativas encontradas en los artículos seleccionados, se destacan los AMR como el futuro de la logística interna en cualquier sector. Aun así, hoy en día sigue siendo una tecnología en desarrollo por lo que los robots más usados y con buenos resultados son los AGVs.

El conjunto de artículos seleccionados en la primera revisión de la literatura no hace referencia a los beneficios o a la razón por la que las empresas usan un método de navegación en particular. Por esta razón, se realizará una segunda revisión bibliográfica enfocada en esta última categoría.

La segunda revisión bibliográfica sigue los mismos pasos realizados en la primera. En este caso, el criterio de selección se limita a artículos de 2016-2020 con las siguientes palabras clave: navigation method y mobile robots. Esta segunda selección de artículos se reduce a 26 artículos. Al igual que en la primera revisión bibliográfica, se han elegido varias categorías de información

para ayudar a procesar la información y crear una conclusión centrada en la pregunta de la investigación anteriormente expuesta.

En conclusión, no se aprecia ningún patrón a la hora de escoger el tipo de método de navegación y la función atribuida a ese robot. En cambio, se puede sacar en claro que el método de navegación visual que se realiza mediante cámaras es el más usado para AMRs. Por otro lado, en esa selección de artículos los AGVs no han tenido tanta relevancia puesto que muy pocas investigaciones se han apoyado en esta tecnología. En conclusión, se puede decir, que el método de navegación óptimo adaptable a cualquier escenario no existe, sino que depende de los requisitos y necesidades de la compañía. Es decir, depende del coste que puedan afrontar, así como de las limitaciones de la planta, de la disposición de las máquinas, de las de los productos o las de las propias máquinas.

Por lo tanto, con respecto a qué tecnología sería la adecuada para automatizar el sistema intralógico se establece la existencia de diferentes alternativas en función de los requisitos de la empresa o las necesidades que éstas buscan solventar.

Aunque el espectro sea vasto y variado, las dos revisiones bibliográficas han permitido identificar la tecnología más usada hoy en día y hacia dónde se dirige la evolución de esta actividad logística. Como ya se ha señalado anteriormente, las dos alternativas propuestas son dos robots móviles: los AGV con su gran historial de buenos resultados y los AMR adaptables y autónomos.

En este contexto, se ha concluido que la industria alimentaria como el resto de sectores está abierto a adoptar mejoras con el objetivo de incrementar la calidad de sus resultados y servicios.

La compañía para la cual se realiza el estudio presenta una distribución fija y sin intención de ampliación. En el contexto de este proyecto y entre los dos robots estudiados, por tanto, los AMR se van a poder adaptar a cualquier espacio y van a poder operar libremente buscando la mejor ruta y el mejor orden de actividades. No obstante, esta afirmación no implica el descarte completo de los AGVs puesto que existen varios métodos de navegación que se adaptan al espacio mediante una serie de sensores que no modifican la planta. Un claro ejemplo serían los AGVs con navegación de guiado óptico.

En esta primera parte del proyecto, se diluce que la solución tecnológica que más se adapta gira entorno a los AMRs o los AGVs con método de navegación que no altere la distribución de la planta. La elección entre ambas alternativas dependerá de las necesidades y restricciones de la compañía.

RESULTADOS DEL CASO DE ESTUDIO

En esta segunda parte de la investigación, se pretende identificar el tipo de robot que mejor se adapta al sistema logístico interno de una fábrica concreta de confitería noruega.

Para poder llevar a cabo este caso de estudio se sigue la siguiente serie de pasos:

1. Introducción de la empresa y búsqueda del área de mejora
2. Análisis de la información de la empresa
3. Creación de las diferentes alternativas
4. Cálculos teóricos de diseño
5. Simulación de la empresa y de las alternativas previamente propuestas
6. Tabla comparativa de costes de cada alternativa

La empresa para la que se realiza el estudio se trata de una confitería noruega de productos de chocolate, azúcar y frutos secos, que colabora con la universidad noruega, NTNU. Es una empresa que opera mayoritariamente en Noruega, pero tiene varios clientes en los países escandinavos. Su beneficio del año 2019 fue de 760 millones de NOKs (76 millones de Euros).

El abanico de productos es extenso y se divide en tres áreas: azúcar, chocolate y frutos secos. En total, existen 127 diferentes productos, los cuales se pueden agrupar en familia de productos en función de su similitud en su proceso de producción.

Durante una visita a las instalaciones de la compañía, se realizaron y evaluaron todos los flujos de material para entender el funcionamiento de la planta y los procesos de cada producto a fin de encontrar la oportunidad de mejora.

Un ejemplo de flujo de material con su correspondiente diagrama spaghetti del área de productos de azúcar sería el siguiente:

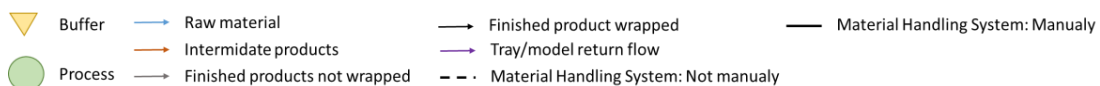
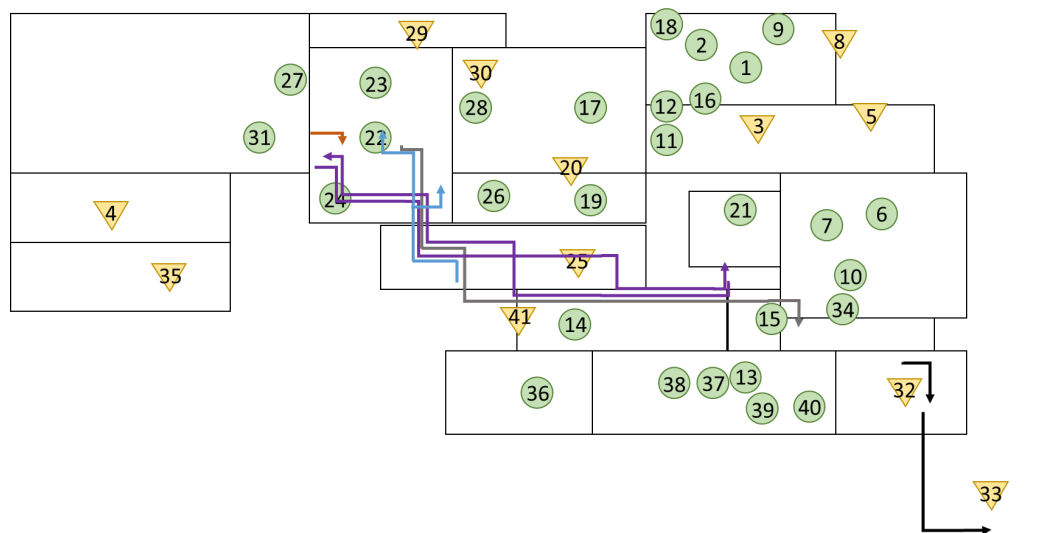
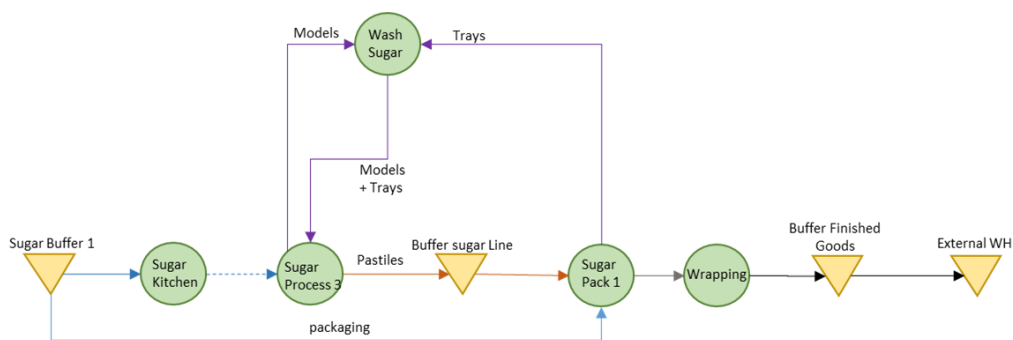

Una vez analizado todos los flujos de material, se detectan las siguientes oportunidades de mejoras:

1. Movimiento de pallets pesados de forma manual ayudados por un porta pallets
2. Distancias largas entre área de azúcar y el puesto de embalaje
3. Pasillos estrechos

4. En la distribución de la planta hay muchos obstáculos (máquinas, stock, personal)
5. Movimientos en vacío de los operarios cuando vuelven a sus puestos de trabajo después de transportar los pallets a la siguiente estación de trabajo

Tras este primer análisis, se decidió centrar la investigación en la mejora del sistema de logística interna del área de azúcar. El objetivo de esta sección constituye la búsqueda de una solución viable y adaptable para poder implementar un robot móvil que absorba las actividades logísticas de movimiento de pallets entre estaciones de trabajo.

Para poder llegar a una solución, primero se han tratado los datos que la compañía ha facilitado. Datos que engloban desde el número de pallets de materia prima y pallets de material de embalaje. Gracias a esta información, se han conseguido saber cuántos pallets se mueven de una estación de trabajo a otra cada día durante un año. Los meses de agosto y septiembre presentaban un comportamiento fuera de lo común, por lo que, tras acordarlo con la empresa, se decidió eliminar estos dos meses del estudio.

Partiendo, pues, de estos datos, se ha podido realizar varias hipótesis necesarias para completar los futuros cálculos. Una vez conocido el volumen de pallets, se ha caracterizado varios escenarios donde se prueban las diferentes alternativas y poder, así, encontrar una solución que se adapte mejor a la situación y a la empresa. Los escenarios creados combinan diferentes niveles de transporte y diferentes robots y son los expuestos a continuación.

A continuación, se presentan todas las combinaciones posibles a estudio y simulación para encontrar la solución más adaptable y que ofrezca un mejor resultado para la compañía:

Escenario 1

Sólo contiene el transporte de pallets entre el proceso de empaquetado y el embalado.

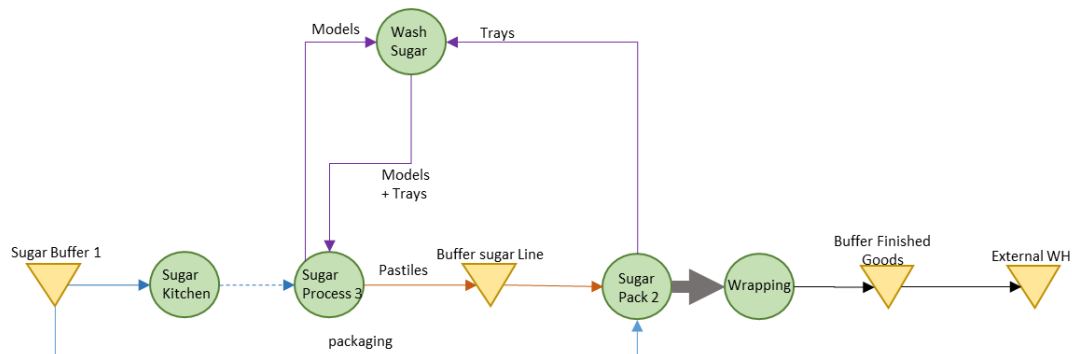

Escenario 2

Añade al escenario 1, el transporte de pallets de material prima y material de empaquetado.

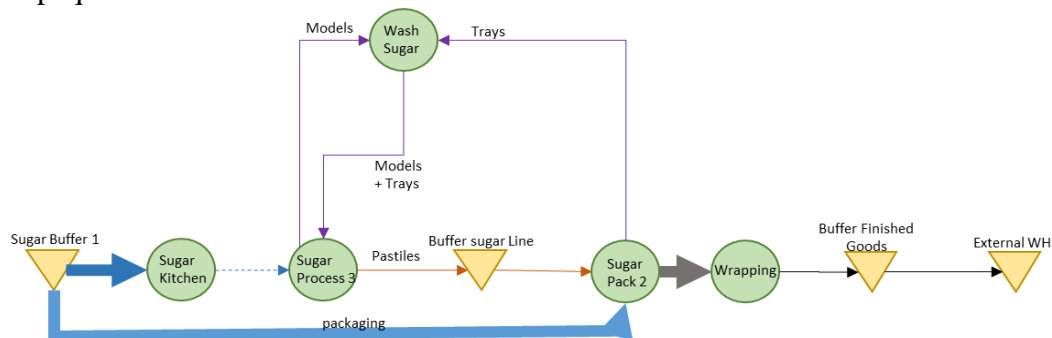

Escenario 3

Se complete el escenario 2, incorporando el transporte entre los diferentes procesos de producción.

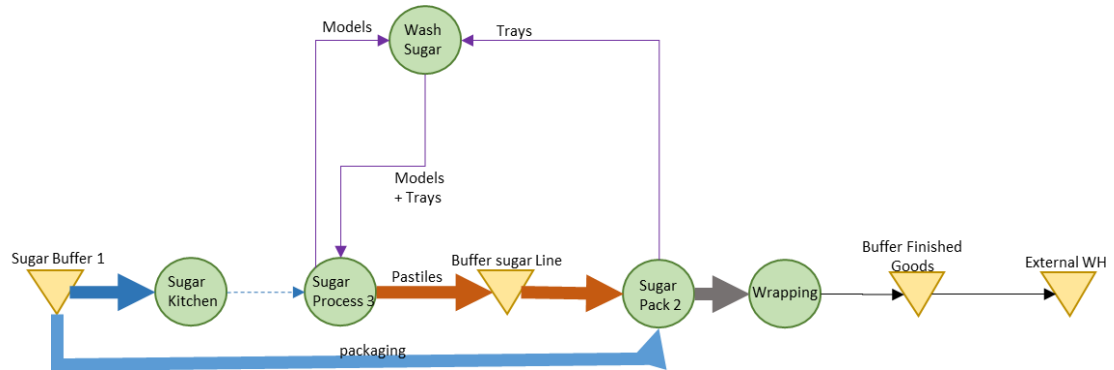

Escenario 4

Se forma con el escenario 3 más los movimientos de pallets del flujo de retorno de los pallets vacíos.

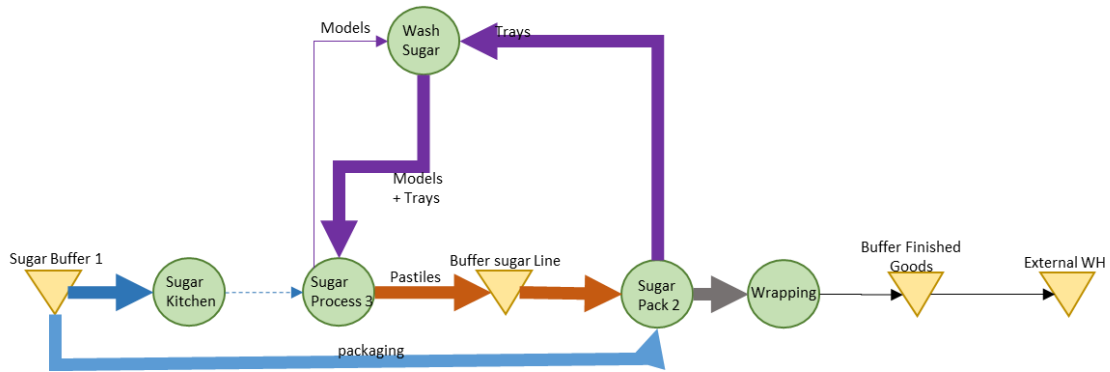

Escenario 5

Se constituye con la suma del escenario 2 más el flujo de retorno de pallets vacíos.

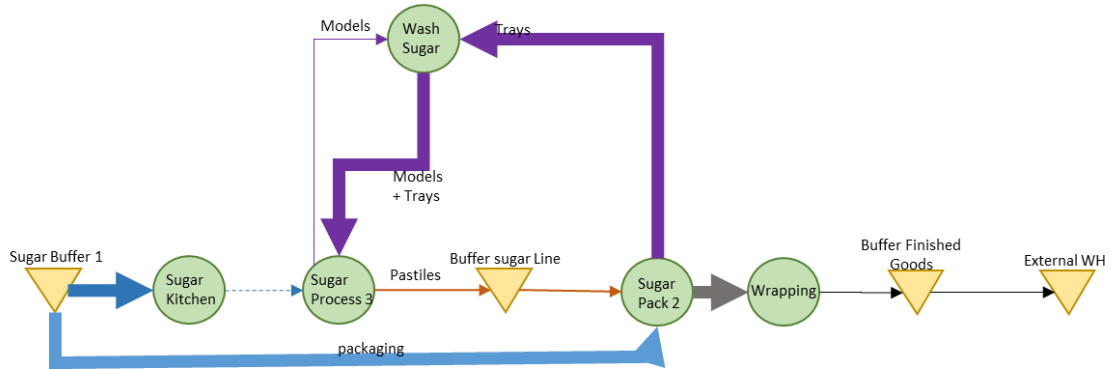

Dichos escenarios se dividen según el tipo de robot propuesto: AGV o AMR. En el caso de los AMRs, los escenarios 3 y 4 no van a ser incluidos debido a que el AMR seleccionado necesita una estructura extra para poder recoger pallets. Dicha estructura requiere una inversión y poner una estructura de este calibre en cada una de las estaciones sería muy caro. Se dejará esta propuesta para futuros trabajos.

Para cada escenario se construyó una tabla From-To para analizar la cantidad de pallets de una estación a otra en cada una de las alternativas. Las tablas elaboradas eran anuales, mensuales y diarias

Pallets/year	SugarBuffer3	SugarBuffer2	SugraProcess1	SugarPack2	SugarProcess2	SugarKitchen	SugarPack3	SugarPack1	SugarProcess3	ChocoWH	Wrapping	WashSugar	Total general
SugarBuffer3				1094,17									1094,17
SugarBuffer2			1094,17	802,52			390,51	131,71					2418,90
SugraProcess1	1094,17												1094,17
SugarPack2										20,61	664,67	802,52	1487,80
SugarProcess2		1094,17											1094,17
SugarKitchen										96,13			96,13
SugarPack3										3,76	291,67	390,51	685,93
SugarPack1										2,82	262,83	131,71	397,36
SugarProcess3		1288,50											1288,50
SugarBuffer1						769,08							769,08
ChocoWH				164,92			30,08	22,58					217,58
WashSugar									2418,90				2418,90
Total general	1094,17	2382,67	1094,17	967,43	1094,17	769,08	420,59	154,29	2418,90	123,33	1219,17	1324,73	13062,68

Esta imagen representa un cuadro From-To anual del escenario 4.

Partiendo de la distancia entre estaciones y ciertos valores característicos de los robots como velocidad y tiempos de descarga, se calcularon el número de robots que necesitaban cada día cada una de las alternativas.

A continuación, se analizaron los resultados de los cálculos para comprender mejor las necesidades de la compañía, siendo los siguientes para cada escenario:

Escenario AGVs: porcentaje de días cubiertos por x número de robots

Nº AGVs	Scce 1	Scce 2	Scce 3	Scce 4	Scce 5
1	100%	100%	81%	67%	93%
2	100%	100%	96%	93%	99%
3	100%	100%	98%	97%	100%
4	100%	100%	100%	100%	100%
5	100%	100%	100%	100%	100%

Escenario AGVs: número de días que se necesitan trabajadores para completar el trabajo

Nº AGVs	Scce 1	Scce 2	Scce 3	Scce 4	Scce 5
1	0,00	0,00	36,00	63,00	14,00
2	0,00	0,00	8,00	13,00	1,00

Escenario AMRs: porcentaje de días cubiertos por x número de robots

Nº ARMs	Scce 1	Scce 2	Scce 5
1	99%	97%	77%
2	100%	100%	90%

Escenario AMRs: número de días que se necesitan trabajadores para completar el trabajo

Nº AMRs	Scce 1	Scce 2	Scce 5
1	0,00	0,00	14,00
2	0,00	0,00	1,00

Una vez analizados los resultados teóricos, se decide que la mayoría de los escenarios se consiguen cubrir con el uso de dos robots. Es por esto que en el siguiente paso se valorarán los diversos escenarios a través de una simulación.

La investigación se completa, por tanto, con una simulación de cada alternativa planteada previamente con el objetivo de comprobar los cálculos teóricos y poder obtener información del comportamiento de la producción en cada escenario.

La simulación se realizó en la versión estudiantil de AutoMod. Para ello, se construyó un plano respetando la disposición real de la planta en cuestión y se programó la simulación para representar lo más fielmente posible a la producción diaria de la compañía, por lo que cada día representado se producen diferente número de pallets.

Como resultado de esta simulación, se obtiene extensa información que ayudará a evaluar los diferentes costes relacionado con cada alternativa. La información recogida de la simulación incluye el número máximo de pallets esperando en cada estación de trabajo para calcular el espacio necesario en cada estación, la media de pallets esperando en cada estación para saber cuál es el coste medio de trabajo en proceso esperando a ser producido y el porcentaje de uso de los robots.

Llegados a este punto, observando los datos recogidos, los escenarios 4 propuestos han sido invalidados debido a que exigen una cantidad de espacio en la estación de lavado para que los pallets recién lavados esperen a ser recogidos.

El último paso del proyecto supone usar todos los datos provenientes de las revisiones literarias, los cálculos teóricos y la simulación para poder conformar una conclusión. Con dicho fin, se ha elaborado un cuadro de costes de cada alternativa. Para poder abarcar todas las posibilidades, se realiza un análisis del que se extraen tres nuevos escenarios: favorable, desfavorable y neutral. La diferencia entre cada escenario es la posición tomada respecto al futuro próximo. El escenario neutral es aquel que representa un futuro constante con pocas variaciones respecto a los años anteriores. En cambio, los otros dos escenarios representan una tendencia positiva o negativa respecto a ese futuro próximo.

El resultado de los tres escenarios es relativamente parecido, por lo que en este resumen se expondrá únicamente el cuadro de costes totales del escenario neutral.

Scenario	Robot	Total cost	% Robot	rate: use/cost
1	1AGV	1410459,27	10,56	7%
2	1AGV	1671029,70	17,34	10%
3	1AGV	4539799,76	55,91	12%
4	1AGV	6613403,12	77,03	12%
5	1AGV	2633837,78	44,21	17%
1	2AGV	2315423,27	5,10	2%
2	2AGV	2662699,69	8,59	3%
3	2AGV	3412902,38	33,41	10%
4	2AGV	10025378,42	48,10	5%
5	2AGV	3487724,30	22,48	6%
1	1AMR	489182,95	8,37	17%
2	1AMR	750847,75	12,63	17%
5	1AMR	1116303,25	32,34	29%
1	2AMR	619157,90	4,10	7%
2	2AMR	880778,87	6,25	7%
5	2AMR	1238994,25	15,67	13%

El coste total se conforma de los siguientes costes:

1. Coste del producto en proceso (WIP) esperando en cada estación de trabajo a ser recogido
2. Coste del espacio reservado en cada estación para que los pallets esperen a ser recogidos
3. Coste de los trabajadores necesarios para complementar el trabajo de los robots
4. Coste de implementación de la solución escogida (software, instalación de sensores, diseño de ruta, etc.)
5. Coste del robot
6. Coste de la electricidad consumida

Los costes elegidos no incluyen todos los costes de cada alternativa, pero sí aquellos que dependen del escenario en el que están y por ello marcan la diferencia.

Esta segunda fase de caso de estudio se enfocaba a encontrar la mejor solución para automatizar el sistema del transporte interno de los pallets en la compañía.

PI.2: ¿Cuál es la mejor solución para automatizar el sistema de manejo de materiales en la Compañía X?

Esta respuesta se ha ido construyendo paso a paso en el análisis. Primero, de los resultados teóricos, se realiza una primera aproximación a las alternativas que ofrecen un mayor grado de viabilidad y que se adecuan a los requisitos de la empresa. Estas alternativas destacadas son los escenarios 1, 2 y 5 con cualquier tipo de robot. Segundo, de los datos recogidos de la simulación, se observa que las alternativas destacadas anteriormente, siguen resaltando favorablemente por bajos costes o alto porcentaje de uso del robot. Con una evaluación más detallada, en donde los costes totales, el porcentaje de uso de los robots y la relación entre estos dos factores, son analizados, se aprecia que los escenarios con AGVs son los que más porcentaje de uso poseen, pero los más caros. Asimismo, teniendo en cuenta la restricción de espacio en la instalación y el descarte de los escenarios 4, las alternativas más aptas se reducen a cuatro opciones con un alto uso del robot: escenario 3 con uno o dos AGVS, y escenario 5 con un AGV o AMR.

De estas cuatro opciones restantes, el escenario 5 presenta los menores costes y el mejor ratio entre coste y porcentaje de uso. Por ello, la solución que más se adapta y más viable para esta empresa es el escenario 5 con un robot. La decisión entre un tipo de robot u otra, si se basa sólo en el coste, se resolvería con la opción de AMR, pero con el AGV se conseguiría un 10% más de uso y no habría que usar ayuda por parte del operador para mover los pallets hasta el punto de recogida.

PRINCIPALES CONCLUSIONES

Las dos revisiones bibliográficas han permitido identificar la tecnología más usada hoy en día y hacia dónde se dirige la evolución de esta actividad logística. Como ya se ha señalado anteriormente, las dos alternativas propuestas son dos robots móviles: los AGV con su gran historial de buenos resultados y los AMR adaptables y autónomos.

En este contexto, se concluye que la industria alimentaria como el resto de sectores está abierto a adoptar mejoras con el objetivo de incrementar la calidad de sus resultados y servicios.

La compañía para la cual se realiza el estudio presenta una distribución fija y sin intención de ampliación. En el contexto de este proyecto y entre los dos robots estudiados, por tanto, los AMR se van a poder adaptar a cualquier espacio y van a poder operar libremente buscando la mejor ruta y el mejor orden de actividades. No obstante, esta afirmación no implica el descarte completo de los AGVs puesto que existen varios métodos de navegación que se adaptan al espacio mediante una serie de sensores que no modifican la planta. Un claro ejemplo serían los AGVs con navegación de guiado óptico.

En la primera parte de este del proyecto, por tanto, se deduce que la solución tecnológica que más se adapta gira entorno a los AMRs o los AGVs con método de navegación que no altere la distribución de la planta. La elección entre ambas alternativas dependerá de las necesidades y restricciones de la compañía.

En el análisis del caso de estudio, se llega a la conclusión que existe la posibilidad de introducir un AMR realizando las actividades marcadas en el escenario 5, es decir, transportar los pallets de materia prima, de material de embalaje, de producto terminado y del flujo de retorno de los pallets usados. Introduciendo esta solución, aparte de conseguir un bajo coste y buenos resultados, se da pie a usar una tecnología puntera y con posibilidad de extender a otras áreas o nuevas funciones debido a su flexibilidad.

ABSTRACT

The purpose of the project is to contribute to the automated mobile robots' investigation which has been developed for a few decades and it will continue for the next years. The use of robots in the industry as a material handling system solution has evolved thanks to the research done but there is room for improvement. In this paper, the research will be focused on food industry material handling due to the lack of investigation done in the last few years. The typical material handling system used in this industry is constituted by basic technology such as pallet jacks, pallet trucks, conveyors, grips, and so on, which facilitates the work done by the operators. Nowadays, the industry has introduced the mobile robots as a new alternative for material handling activities and more different tasks. By using the knowledge developed by previous research, this TFM searches for possible improvement in the material handling system through the implementation of mobile robots. In particular, this TFM aims to understand the benefits and constraints of the implementation of automated robots and analyze whether this technology meets the food factory requirements. The development of this project involves two systematic literature reviews and a case study. This last one is used to better understand the topic and to validate the conclusions reached with the literature review too. Results from the literature review suggest the possibility to implement AMRs or AGVs technologies. The simulations carried out in the case study finally suggest that the best scenario is where AMR technology is introduced.

<u>1.INTRODUCTION</u>	<u>1</u>
1.1 MOTIVATION	1
1.2 PURPOSE.....	2
1.3 METHODOLOGY	2
1.4 THESIS STRUCTURE.....	3
<u>2.SUPPLY CHAIN STRATEGY.....</u>	<u>5</u>
2.1 FOOD SUPPLY CHAIN MANAGEMENT	7
2.2 LOGISTICS.....	9
2.2.1 MATERIAL HANDLING	10
2.2.2 SMART LOGISTICS.....	10
2.2.3 AGV	12
2.2.4 ARM	14
2.3 IMPORTANT DEFINITIONS: RESPONSIVENESS, FLEXIBILITY, AND EFFICIENCY	15
2.3.1 RESPONSIVENESS	15
2.3.2 FLEXIBILITY.....	15
2.3.3 EFFICIENCY.....	15
<u>3. FIRST SYSTEMATIC LITERATURE REVIEW ON TECHNOLOGY</u>	<u>17</u>
3.1 METHODOLOGY	17
3.1.1 SEARCH STRATEGY	18
3.1.2 DESCRIPTIVE ANALYSIS	19
3.1.3 CATEGORY SELECTION	20
3.2 RESULTS OF THE FIRST LITERATURE REVIEW	21
3.2.1 INDUSTRY	21
3.2.2 TECHNOLOGY INVESTIGATED	25
3.2.3 REASONS IMPLEMENTATION	25
3.2.4 BENEFITS	26
3.2.5 LIMITATIONS	26
3.2.6 GUIDING METHODOLOGY	26
3.3 CONCLUSIONS	27
<u>4.SECOND SYSTEMATIC LITERATURE REVIEW ON TECHNOLOGY.....</u>	<u>29</u>
4.1 METHODOLOGY	29
4.1.1 SEARCH STRATEGY	29
4.1.2 CATEGORY SELECTION	30
4.2 RESULTS OF THE SECOND LITERATURE REVIEW.....	30
4.3 CONCLUSION.....	35
<u>5.CASE STUDY.....</u>	<u>37</u>
5.1 INTRODUCTION	38

5.2 METHODOLOGY	42
5.2.1 ANALYSIS OF THE COMPANY AND THEORETICAL CALCULATIONS:	42
5.2.2 SIMULATION	43
5.2.3 COMPARISON COST CHART.....	44
5.3 MATERIAL FLOW MAPPING	45
5.4 THE SPAGHETTI DIAGRAM	46
5.5 THEORETICAL CALCULATIONS.....	51
5.5.1 DATA ANALYSIS.....	51
5.5.2 SCENARIO DESIGN	54
5.5.3 FROM-TO CHART.....	56
5.5.4 NUMBER OF ROBOTS.....	57
5.6 SIMULATION	60
5.6.1 CONFIGURATION LAYOUT	61
5.6.2 PROGRAMMING THE TRIGGERS.....	61
5.6.3 SIMULATION AND INFORMATION	62
5.7 COMPARISON COST CHART	62
5.7.1 COST WIP YEAR.....	62
5.7.2 COST SPACE WIP YEAR	62
5.7.3 COST OPERATOR.....	63
5.7.4 COST ROBOT	63
5.7.5 COST IMPLEMENTATION.....	63
5.7.6 COST ELECTRICITY	63
5.8 RESULTS.....	64
5.8.1 NEUTRAL SCENARIO	64
5.8.2 UNFAVORABLE SCENARIO.....	65
5.8.3 FAVORABLE SCENARIO	65
5.9 DECISION AND DISCUSSION.....	66
6.CONCLUSION	69
<u>ACKNOWLEDGMENT.....</u>	<u>2</u>
<u>ANNEX</u>	<u>71</u>
CODE AUTOMOD	71
COMPARISON COST CHART COMPLETE	78
PLANIFICACIÓN TEMPORAL Y PRESUPUESTO	81
<u>IMAGES.....</u>	<u>82</u>
<u>TABLES.....</u>	<u>82</u>
<u>REFERENCES</u>	<u>83</u>

1. INTRODUCTION

1.1 Motivation

Since the beginning of the 21st century, there has been an increased technological transformation where robotic automation is taking an important role (Y. Fernando, 2016). Nowadays, an intelligent robot with independent capability is widely used in manufacturing, and gradually extended to non-manufacturing (C. Wang, 2016). In particular, mobile robot systems have been a growing area of research during this period due to the benefits of these systems such as increasing efficiencies or reduce cost (N. Naidoo, 2019). One of the reasons for this usages scale of robots is the need for the industries to modernize themselves and increase their production capacities (Y. Fernando, 2016).

In parallel, the food industry is evolving trigger by the new market and customer requirements (F. Jovanel, 2003). For meeting this new demand, the food industry is evolving into more responsiveness and efficient production (A. Romsdal, 2014). In this technology scenario, the food industry has been updated.

The first approach of robotization in the food industry took place in the 1980s and it was focused on the role of robots in palletizing, material handling, and tertiary packaging. At that moment, companies could not encourage a higher level of robotization due to the investment risk required. However, a few years ago, with the big growth in automation, the current trend has changed to robotic operations including processing such as slicing (Y. Fernando, 2016). Moreover, the sales of industrial robots grew 19% per year between 2011 and 2016 intending to improve flexibility and reconfigurability required for product variability (F. Bader, 2018).

As it is observed, robots can be implemented in almost every area inside a food industry facility. However, the technological advances, in the food industry, are more focused on the processing robots rather than the material handling ones (D.G. Caldwell, 2013). As a consequence, material handling robots are used to have a basic design and do not have a wide range of applications.

Furthermore, as a contradiction, material handling in the manufacturing industry is a relatively mature research field, where many technologies, including autonomous robotics, have been widely applied (J. Wan, 2018). Besides, there are a few research were the implementation of autonomous mobile robots as a material handling system solution has a great impact on their productivity and efficiency. Some examples are applied in a hospital intralogistics system (S. Jeon, 2017) or manufacturing company (B. S. Kumar, 2018). Also, some authors conclude their investigation suggesting the use of robots as a material handling system for better performance in their results (H. Ardiny, 2015) (J.A. Estefanía, 2013) (A. Vale, 2014).

A particular example of robots used as a material handling system is the Automated Guided Vehicle (AGV). The basic principle of the operation of the traditional AGV system is in a pre-defined route. At first, this route operated by the induced magnetic field on the floor. Then, the footprint on the floor or magnetic tape on the floor were used. Nowadays, AGVs incorporate GPS navigation modules. Besides, they can communicate with other ones and keep simple traffic rules (G. Fedorko, 2017). This evolution has led to a new update of the robot: Autonomous Mobile Robots (AMR). What is more, this evolution has been driven by customer demand which pushes the industry to be more flexible, adaptability, and pro-activity (A. Lourenço, 2016).

1. Introduction

The suitability of each type of AGV or AMR depends on the products or materials that are planned to be moved, the facilities where the robots need to move, the investment that the company is willing to perform, and so on (A. Lourenço, 2016) (I Lajmi, 2019).

In this scenario, Company X, one of Norway's largest family-owned confectionery manufacturers is located. Its level of automation and robotization is high in all the processing and packaging operations. However, the material handling system has a low implementation of automation. Most of the material transfers are made manually.

The company is looking for new solutions that can improve their service, efficiency, productivity, decrease its expenses incurred by increasing its technology level.

1.2 Purpose

Therefore, this Master Thesis will study the opportunity of implementing an autonomous mobile solution (AGV or AMR) as a material handling system in the sugar area at the company's facility. The objective is to evaluate Company X's scenarios and design a solution suitable for it taking into account factors as the investment needed efficiency/productivity improvement or sustainability.

The purpose of this project will be to answer the following questions:

RQ1: Which is the suitable technology for automating the material handling system in a food industry facility which its layout is already fixed?

RQ2: Which is the best solution for automating the material handling system in Company X?

The objective of this research question is to analyze the different technological alternatives that can be used for automating the material handling system. Thus, guiding methods, the need to implement new structures, and the use of sensors will be evaluated aiming to understand which alternatives can be implemented in a food factory in which its layout is already set up.

The objective of this research question is to understand Company X's requirements and design a material handling system solution that meets these requirements. This design will gather the route, the number of robots needed, the workstations involved, and the area of parking. It will carry a deep analysis of the different alternatives and it will be helped by a simulation model. Furthermore, to conclude there will be a comparison between all the suitable alternatives found at the RQ1. This comparison will be concluded in a visual chart. This answer will go step by step analysis of the production plan data and all the other requirements from Company X to conform to the solution design.

1.3 Methodology

For the development of this thesis, a simulation model will be used to understand better the behavior of every alternative suggested during the development and give a more realistic point of view.

1.4 Thesis structure

Before answering these questions, the thesis provides a brief explanation of the main terms and situation of the topic in the section 2 'Background'. Besides, aiming to answer the first research question, it is developed a literature review. This section 3 and 4 'Fisrt /second systematic literature review' gathers the explanation of the methodology used, and the discussion of the results. To provide a better study, this section holds two literature reviews to provide an accurate conclusion. Afterward, following the same structure as the section before, the case study for simulation is introduced. This next section 5 'Case of Study' has the aim of answering the second research question. At the end of all the investigation, there will be a section 6 'Conclusion' that highlights the main ideas of all the Thesis.

2. Supply Chain Strategy

The principal objective of the companies' supply chains is to reach a better performance. This performance can be measured by the efficiency, productivity, minimizing the expenses, and so on. In this pursuit, the business models are more complex caused by the increase of participants, looking for a seamless chain's management and globalization. This demands higher customized logistics solutions and an increase in the efficiency of execution escalates. This triggers the need for better information flow and better monitoring of transportation operations (K Lumsden, 2008).

Also, customer demand has turned over. Society requires products that are widely affordable and customized, commanding continuous updates of them. These demand changes are expected to continue or even accelerate shortly. Such requirements impacted production leading to seek improvements in the current supply chain practices (O. Ahumada, 2009). F. Jovenal (2003) highlights the three main necessities that will influence this improvement: productivity, customization, and agility.

Every industrial sector has been involved in this demand change, including the Food Industry. In this case, it is observable how the new customer requirements have a direct impact on the business strategy.

Traditionally, customers were offered high-quality products at low prices. This scenario was engaged with the production strategy 'make to stock' which provided a short delivery time increasing the service level and reducing production cost working with large batches. After the demand changes, the responsiveness has been defined as a necessity for achieving competitiveness. This means being able to respond quickly to any changes in the demand requirements (A. Romsdal, 2014). This leads to a strategy modification that can meet the new necessities identified.

Furthermore, the supply chain of food industry has been described as an uncertain and complex (P. Barsing, 2018) due to the perishability of goods and to difficult forecasting. Besides, few authors also mention the following characteristics: high-demand volatility, high-product variety (P Barsing, 2018), seasonality, or extract regulation (J. Jochemen, 2016).

Barsing (2018) mentions that in this uncertain scenario, effective control of the material flow across through the supply chain is required. He highlights that a third of the cost incurred by an organization is related to the distribution process and activities related. Hence, for achieving a better performance in the material flow, efficient management should be taken into consideration. As a result, most companies have adopted a responsiveness strategy.

However, implementing a responsiveness strategy or rising the responsiveness' level at a company triggers an increase in the incurred cost which can be understood as a lower efficiency. Despite this belief, on the other hand, if any implementation is done, the traditional strategy would not be able to meet the new demand requirements. Romsdal (2014) remarks that the consequence of wider product range, uncertain demand and perishability would be large amounts of waste products expired as stock-outs join to other costs related to them.

In particular, the food industry is evolving to a more flexible production in its supply chain supported by a more suitable production planning and control for a different market and product requirements in a more customized manner. This new strategy is aligned with efficiency in

2. Supply Chain Strategy

production and inventory (A. Romsdal, 2014). As was mentioned, this evolution is driven by customer demand.

Continuing with Romsdal's statement, the pursuit of efficiency in production and inventory could be faced with different approaches. In the line of the study, the focus will be on the distribution process and activities related due to the impact on the cost incurred and the several investigations which this paper is built on. Especially, Semih Onut (2009) agrees that only the handling activities generally account for a thirty-forty percentage of the production cost. He also highlights the importance of the material handling role in today's manufacturing system and the productivity rate.

J van der Vorst (2000) highlights that the potential for improvement is based on the flexible production where the logistical network has to take advantage of the recent technological developments and cope with the efficiency goals. He explains that there are three main categories distinguished as interested in supply chain development: social-economic, market structure, and technological development. The last category is the one related to the distribution activities. In particular, he points out that technology is the driver for the development of logistical activities due to it can help in their coordination and efficiency defeating the uncertain and complex of the supply chain's structure. This statement agrees with what Romsdal (2014) supports, the uncertainty cannot be solved with building inventories or providing additional capacity as it used to be causing logistic cost unnecessarily and providing higher flexibility lack of the production organization.

Both references, S. Onut (2009) and J van der Vorst (2000) mention the improvement in logistics as a driver for achieving the competitiveness that the companies and, in particular, the food industry are looking for meeting the new demand requirements.

Also, in the logistic area of investigation, several authors, as Winkelhaus (2019), argue about the relevancy of the logistics activities' role in efficiency achievement. Winkelhaus (2019), especially, supports that logistics fulfill customer demands. He explains how a new production and logistic strategy can avoid an increase in cost and competitive disadvantages on global markets during the current turn towards more customized products.

Connecting the idea of J van der Vorst (2000) about the technology as a direct factor for supply chain development and the thoughts of Winkelhaus (2019) and Onut (2009) about the impact of logistic on the efficiency of production and performance of the supply chain, the investigation points out to technology development at the logistic sector. In this context, the terms logistics 4.0 and smart logistics appear. Even though these terms are not defined in too many articles, it is defined as a new era in logistics based on the use of the new digital technology as IoT, big data, or automated and autonomous solution implementations in the line production and the supply chain (S. Winkelhaus, 2019).

Although robotized solutions had been accompanying the development and evolution of the companies and supply chains, robotized solutions implementations are widely expanding through all the sectors due to the performance improvement presented: increasing productivity and production quality (C: Wang, 2016). Especially, in the food industry, this technology is being used. The most common applications are picking, packing, and palletizing hence material handling activities (Y. Fernando, 2016). Also, some authors go ahead pointing to mobile robots as the main technology in this field of logistics (M. Faisal, 2018).

The investigation will be developed in this background where the mobile robots are suggested as a logistic solution to improve productivity, efficiency, and the general performance from the production line to the whole supply chain. In particular, the logistic activity studied will be the material handling system according to Semih Onut (2009) and other authors who mention it as an important activity that generates costs with not adding value.

To understand better this background already explained, the following sections will define in detail the concepts that are being used during the development of this research such as what is a food supply chain and how it works or what is material handling or what is a mobile robot and the relationship with Company X.

2.1 Food Supply Chain Management

The term supply chain is being described as ‘a system whose constituent parts include material suppliers, production facilities, distribution services and customers linked together via a feed-forward flow of materials and a feedback flow of information’ (Stevens, 1989).

G. Stevens (1989) highlights that the food supply chain is different from the manufacturing industry. This statement can be applied to all the different sectors. Aligned with the definition of the supply chain, each one even offering the same product can have different echelons, suppliers, processes, and so on. However, with this statement, the author wants to advance the complexity that the food products are going to imply.

As an overview, in the food industry, there is a wide range of food products with different requirements and characteristics produced by the same producer. An example of complexity in this particular supply chain is that they have to deal with different perishable degrees in each product (A. Romsdal, 2014). A fresh product such as fruit or vegetables has a higher level of perishability rather than a processed product such as canned food (J. van der Vorst 2000). However, as a complex supply chain such as other industry sectors, it needs to deal with the uncertainty and production lead times. It needs to fulfilling the orders of different customers who demand different quantities of different products at diverse frequencies without forgetting the volatility of the different markets where the producers work (A. Romsdal, 2014).

As it was mentioned before, the complexity is due to the increasing number of products offered for each producer. This is considered by many authors as one of the principals and distinguished characteristics from this type of supply chain. The reason behind this strategy is due to the food industry is a very competitive industry that uses having a huge range of heterogeneous products to fulfill the customer’s demand (C.A. Soman, 2004). This strategy not only involves the increase of the service level but the introduction of new products and the need for its forecasting, overstocking caused by the uncertain forecast of all the different kind of products and its associated costs, and warehousing and distribution management gets more complicated (G. Stevens, 2010).

Furthermore, the costs incurred are increased by the fact that the production lead times are much longer than the delivery lead time. This leads to the use of large finished goods inventories to meet customer requirements for a fast response, which also concludes with a high rate of obsolescence products (A. Romsdal, 2014).

2. Supply Chain Strategy

However, more characteristics differentiate the food supply chain and the rest. They can be summed up as seasonal demand and supply; important management in safety, risk, and quality factors, as soon as the food has a direct impact on human health; and perishability and volatile demand. All these characteristics push the need for responsiveness and short lead times through the supply chain (G. Stevens, 2010).

However, this complexity was not ever since part of the food industry. The food industry has evolved driven by customer demands. This evolution has been influenced by economic, social, environmental, and technological factors that have led to changes in the strategy. In the beginning, supply chains were short, local, and simple (G. Stevens, 2010). They were focused on the quality of the product and used economies of scale as an efficient strategy. Nowadays, with the new customers' requirements, the food industry has changed its strategy to meet these requirements. This new strategy understands that every product is different and needs to have a suitable strategy for each one (A. Romsdal, 2014).

The last statement supports that products with different characteristics need different management product strategies. Aligned with this statement, J. van der Vorst (2000) proposes at his investigation a division of food products and investigates their suitable strategy for each. Each strategy should meet different product's characteristics. He divides between fresh products and processed products, and in each supply chain, the echelons and processes are similar but not the same. Also, Soman (2004) adds that the strategy should take into account, not only the products' characteristics but the production process, market characteristics, and production control. Besides, Rosmdal (2014) uses the strategy fit theory written by Marshall Fisher (1997) to underline the necessity of the new strategy to meet with the different product characteristics and the customers' requirements.

Moreover, for a better understanding, Romsdal (2014) proposes an easy example of the necessity of different strategies. If there are two types of products. The first type has a short shelf life, less than 20 days, and the second type, more than a year. Even though the differences, the customer wants to have both of them at the same time in the same market available. If in this scenario, the same strategy is applied for both products, either the first product is obsoleted before reaching the customer or the customer needs to wait for their product. Both endings are not according to the service level that the food industry is required to offer.

However, designing a suitable strategy is a difficult task. There is a trade-off identified which balances the efficiency and the responsiveness required for meeting the customer necessities (A. Romsdal, 2014). The first one is related to the cost-reducing, and the second one, with giving a fast response to the customer and improving the service level.

As it has been introduced before, each product has its characteristics that should define the management product strategy. However, these characteristics have been identified, gathered, and listed.

Moreover, all the researchers have defined the same categories for these characteristics. As a wide overview, the principal ones are the limited shelf life or perishability, the uncertain demand (O. Ahumada, 2009), seasonality, specific legislation, and changing product quality (J. Jochem, 2016).

The most outstanding researcher, Romsdal (2014), has developed an extended and accurate investigation. According to her, the characteristics can be classified based on the product,

market, and production system. As the rest of the authors, Romsdal mentions the perishability and variety as principal product characteristics. However, she goes deeper and suggests as product characteristics the volume variability and innovation. In the case of market characteristics, demand uncertainty has already appeared. However, this section goes beyond and contemplates the different lead times within the supply chain and the inventory management complex as the supply chain as the limited ability to storage. Furthermore, in the third group related to the production system, it is mentioned the uncertainty across the supply chain, not only caused by seasonality but high reliability for raw materials. All these characteristics are gathered in the following framework by Romsdal (2014).

<i>Aspect</i>	<i>Description</i>
Product characteristics	
Perishability and shelf life	High perishability, with shelf life constraints for raw materials, intermediates and finished products.
Complexity	Varied, with mainly divergent product structure and increasing variety in products, packaging sizes and recipes
Variety	High and increasing, particularly for promotions. High percentage of slow-moving items.
PLC, innovation and NPD	Decreasing PLC, with high failure rates for new products.
Volume and volume variability	High volume, with higher volume variability in downstream processes.
Market characteristics	
Delivery lead time and lead time variability	Varies by product, but generally retailers demand and receive frequent deliveries and short response times. Demand mainly met from finished goods inventory.
Demand uncertainty	Varying and increasing, largely caused by high and increasing frequency of promotional activities. Strong presence of bullwhip effect.
Inventory management and stock-out rates	Limited ability to keep stock. Periodic ordering. High and stable stock-out rates. Cost of lost sales often higher than inventory carrying costs.
Production system characteristics	
Production or make-to-order lead time	Product dependent, but generally long lead times and low degree of postponement.
Plant, processes and technology	Adapted to low variety and large volumes. Mainly integrated and continuous production process on capital-intensive equipment with long set-up times and high set-up costs.
Supply uncertainty	Some uncertainty, mainly caused by seasonality, demand amplification and economy of scale thinking, but generally high reliability for raw materials.

Image 1 Food supply chain characteristics (A. Romsdal 2014)

For managing all this complexity and meeting every characteristic, the supply chain needs to have a fast response to demand variability and an efficient strategy to reach a competitive level. Moreover, this can be defined as the requirements of the food supply chain: responsiveness and efficiency (A. Romsdal, 2014).

2.2 Logistics

A simple way of describing may be as Winkelhaus (2019) does: 'the planning, implementing and controlling efficient, effective flow and storage of goods and services from the beginning point of external origin to the company and from the company to the point of consumption for the confirming to the customer'.

Besides, J. A. Estefanía and B, Ramos (2013) add to the definition 'planing, organization, and control of all the activities about the material and product handling included the associated flow of information'. They, also, remark that the main constraints set by the customers' satisfaction are the cost.

2. Supply Chain Strategy

Logistics is a wide investigation area that embraces every single activity, process, the connection of moving goods, and their design, control, and management. In particular, the connection echelon with this project is the material handling system that gathers the internal goods' movement in the production facilities. More in-depth, the automation solutions.

In this section, the terms of the material handling system, smart logistic, AGVs, and ARM are going to be introduced for a better understanding of the topic.

2.2.1 Material Handling

M. G. Kay (2012) define material handling as “short-distance movement that usually takes place within the confines of a building such as a plant or warehouses and between a building and a transportation agency”. V. Gupta (2013) adds that material handling accounts for 35% of all employees, 45% of all factory space, and 80-90% of production time. This statement underlines the important role that material handling has in manufacturing systems (S. Onut, 2009), especially in the productivity plant (V. Gupta, 2013).

However, a large list of authors highlights the relevant role of the material handling activities and its impact on the production performance and efficiency, they also mention that these activities are an important part of the incurred cost of a company. Furthermore, most of the researchers, describe these activities as a non-value-added activity. However, M. G, Kay (2012) endorses the value of the material handling activities not as formation utility, but as a time and place utility. For example, the value added by having parts stored next to a bottleneck machine is the savings associated with the increase in machine utilization minus the cost of storing the parts at the machine (V. Gupta, 2013).

Moreover, the material handling term involves a wide range of solution variety suitable for the different scenarios at the industrial facilities. For a first and general approach to this term, M.G. Kay (2012) create a classification based on the material handling functionality. There are three categories. In the first place, transport equipment is described. It is focused on the material movement from one workstation to another such as conveyors, cranes and, also, it includes manual solutions. In the second category, it appears the positioning equipment that is used to handle material at a single location. This category also has manual solutions. Finally, the unit load formation equipment completes the third category. This equipment is used to maintain material integrity when the goods are transported and stored.

In the past few years, there has been a tremendous growth of material handling technology and equipment types; robots, automated guided vehicles, computerized picking systems, and so on (V. Gupta, 2013).

The researchers investigating this topic has named this current as smart logistics or, more common, logistics 4.0.

2.2.2 Smart logistics

Logistics 4.0 or smart logistics is the logistical system that enables the sustainable satisfaction of individualized customer demands without an increase in costs and supports this development in industry and trade using digital technologies (S. Winkelhaus, 2019).

This definition is completed by the five characteristics of the smart logistics that Strandhagen (2017) mentions: real-time Big Data analytics (BDA), for example for optimized routing; reduced storage requirement due to new manufacturing techniques; autonomous robots with

tracking and decision systems leading to optimized inventory control; information exchange in real-time avoiding e.g. bullwhip effects; and no information disruption due to smart items.

The project development is related to the third characteristic: autonomous robots. The objective of this thesis is the implementation of an autonomous robot as a material handling system to fulfill Company X's requirements.

Since a few years ago, the robot has been playing a progressively significant role in addressing labor shortages, increasing productivity, improving product quality, and reducing production costs (C. Wang, 2016). Mobile robots, in particular, have been a growing area of research in the past few decades. This is due to the benefits of these systems in a variety of applications such as material handling. Manufacturers have realized the insurmountable advantage of using mobile robots in their processes to increase efficiencies and reduce costs while operating autonomously alongside humans (N. Naido, 2019).

Nowadays, the application of robotics in internal logistics focused on packaging and palletizing, handling two jobs links (C. Wang, 2016). However, the manufacturing industry has grown immensely reaching the fourth industrial revolution, Industry 4.0. Hence, in a world where digitalization and real-time information are the norms (N. Naido, 2019), the development of the logistics industry needs the support of the robot technology revolution (C. Wang, 2016).

However, this evolution is not supported by every author. According to Bonini (2015), implementing robots as material handling systems or logistics incur higher costs and higher technical difficulty than applying them to the field of manufacturing. On the other hand, the researchers in favor of the implementation, they argue that there are some cases where the robots can offer better performance than the human operators. One example is the unloading and loading of containers. This activity embraced at the material handling system, if it is done by a robot, the productivity rate would be higher than if it is performed by a human operator.

This statement enhances the trade-off of this evolution. The choice between robot or humans is among costs (investments), performances (productivity rate), and flexibility (capacity of coping with different scenarios and situations) of autonomous systems (M. Bonini, 2015).

Robots in the industrial sector have evolved from powerful, stationary machines into sophisticated, mobile platforms to address a broader range of automation needs. Autonomous mobile robots utilize feedback from sensors to navigate their environment. Furthermore, they have greater in-built intelligence and can detect obstacles present on its path and recalculate a route around the obstacle to get it to their destination (A. Liaqat, 2019). According to this, the robotic system needs to have a high precision navigation function to carry out the static or dynamic trajectory planning, and then control the robot along the predetermined trajectory forward (C. Wang, 2016).

Autonomous mobile robots have found applications in various industries due to their high efficiency and low operating cost. The challenge, however, is to develop a reliable system that can fully integrate into the existing factory environment addressing complex logistics operations with simple solutions available in the market (A. Liaqat, 2019).

The core of this thesis is the difference between the AGVs and ARMs that make one of each a suitable solution for Company X's facility. Both solutions are part of this technological revolution of the material handling system and logistics.

2.2.3 AGV

Fedorko (2017) defines the AGVs as automatically guided and drive vehicle or equipment which is replacing the transport and part of the handling of the material, part of the internal logistics activities.

The same author, Fedorko (2017) briefs the evolution of the AGVs in a few paragraphs. He highlights that the principle of the operation of the first AGVs is a pre-defined route placed on the floor, which is followed by reading devices that are located at the AGV. In the beginning, the routes operated on an induction principle; then, it evolved to color lines principle which was tracked by color footprint sensors placed at the AGV. Nowadays, the latest and updated versions use GPS navigation modules to navigate and can communicate with other AGVs.

However, during the evolution, between the first version of AGV to the latest embraces more diverse versions that Fedorko (2017) hasn't mentioned. The MHI, material handling, logistics and supply chain organization, classifies seven different types of AGVs.

Laser Triangulation

It is considered the most popular method of AGV navigation. The vehicle is mounted with laser scanners that are going to strobes for the reflective targets that are placed throughout the facilities at know positions. With the information captured by the sensors, the vehicle control algorithms calculate the exact vehicle position via triangulation (MHI org).

Inertial navigation system

In this navigation method, the reference points are embedded in the floor at certain coordinates in a map of the system. The vehicle sensors will detect the reference points as it passes over them. With a wheel encoder placed on the vehicle, the distance traveled is calculated. Moreover, the vehicle is mounted with a gyroscope that measures the vehicle's heading. These three devices will determine the vehicle's location (MHI org).

Magnetic tape navigation system

The route is set up by magnetic tape adhered on the floor. The vehicle will move by detecting the magnetic path with a sensor underside it (MHI org).

Grid Navigation System

This navigation method is similar to the Inertial navigation system already explained. However, instead of embedded the reference points at certain coordinates, the floor is a grid pattern of these reference points. The vehicle will use the feedback from the reference points, the gyroscope, and the wheel encoder to determine the vehicle's location.

Natural feature navigation system or camera guided

The main difference between this navigation system and the rest is that there is not a reference path or references points. In this case, the vehicle will use reference images of the operating area that have been previously recorded and stored in its memory. The vehicle's position is calculated based on its relative position compared to those references. The devices used for records feature during the setup and sense features during navigation (MHI org).

This stride is the trigger event for developing autonomous mobile robots which are going to be explained in the next section (G. Fedorko 2017).

Wire navigation system

This navigate system is similar to the Magnetic tape navigation system, although the path embedded on the floor is a wire. The devices required for detecting a signal from the wire are antennas. Besides the signal receptors, the vehicle uses encoders on wheels to calculate the distance (MHI org).

Optical navigation system

In this method, the route is fixed up to the floor by chemical or tape strip. The vehicle has an onboard sensor which allows it to detect the path.

Mechanical guided

The vehicles move on a rail fixed up on the facility's floor.

MHI org provides a visual chart comparing the performance and costs of the main automated robot transport systems. The chart uses the different systems of guiding implement in each method.

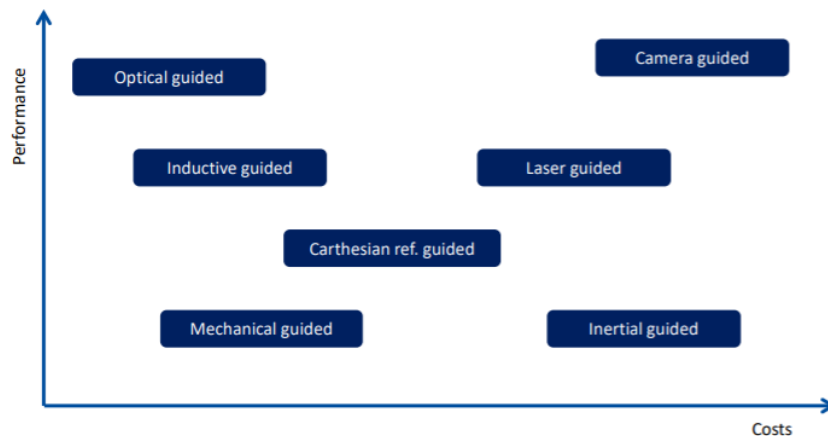

Image 2 Comparison Chart of Navigation methods (MHI org)

The AGVs can also be sorted by the functionality they offered. As it was introduced before, Kay (2012) develops a classification of all the different types of the material handling system, including the AGV family, sorted by functionality. In this classification, the AGV family is included in the transport equipment section. Moreover, this section gathers four different group conveyors, cranes, industrial trucks, and manual. Inside the industrial trucks, the AGVs are allocated.

Kay (2012) highlights five different AGVs:

Tow AGV

It is described as an automated version of a tractor trailer. It is used to pull a train. Normally, trailers are usually loaded manually.

2. Supply Chain Strategy

Unit load AGV

This system is composed by decks that can be loaded manually or automatically. The deck can include conveyor or lift or lower mechanism for an automatic loading procedure.

Assembly AGV

The robot carries the product through the assembly line moving from one workstation to another, stopping in each workstation so the operators can process the product.

Light load AGV

This type of system is designed for transporting light loads. The AGV is composed by many racks where the loads can be placed.

Fork AGV

As the name explains, this is a fork lift with an automated guidance. Typically, it has sensors on forks for pallet interfacing.

On the other hand, the other solution analyze at this project is ARM.

2.2.4 ARM

Fedorko (2017) introduced the link between the AGVs and the ARMs. He introduces the autonomous vehicles as robots which its guiding method is based on reference images and the input from the camera they hold.

However, this author does not call them ARM, he names these robots as autonomous vehicles AGVs.

Lourenço (2016) explains the reason for the evolution from automated to autonomous vehicles. In his research mentions that the AGVs operate with the required predictability and repeatability but the new management strategies with a dynamic shop floor ask for higher flexibility and the ability to avoid obstacles.

The demand for flexibility, adaptability, and pro-activity increases the need for smarter agents within a shop floor to run more complex tasks. Hence, aligned with this new industry requirement, the autonomous robots were designed.

Lourenço (2016) introduces a comparison chart between AVGs and ARMs to conclude his investigation:

COMPARISON	TRADITIONAL VEHICLE AGV	AUTONOMOUS VEHICLE AGV
MANEUVERING	movement acc. to guiding elements , tag, color line, magnetic tape etc.	free movement
INTEGRATION	expensive and lengthy	easy and simple
OBSTACLE DETECTION	stop and waiting	move around

Image 3 Comparison table between AGV and AMR

As the chart shows, the difference between the two alternatives is based on the necessity of seeking a flexible solution.

Along with the state of art and the development of this paper, there are some relevant terms brought up. To give a better understanding of the topic, the following section will be focused on these terms and their definitions.

2.3 Important definitions: Responsiveness, Flexibility, and Efficiency

2.3.1 Responsiveness

This term is defined by Romsdal (2014) by three statements. The first one is replenishment speed or the ability to quickly respond to customer orders within the customer order lead time allowance. The second one is supply chain speed or the ability to respond to customer orders within supply chain lead time allowance. The third statement is volume flexibility or the ability to quickly respond to changes in the required level of aggregated output.

2.3.2 Flexibility

Flexibility is regarded as an attribute that provides a manufacturing system to withstand a certain level of variations in partial styles without any interruption in the production line (G. Manu, 2018).

The same researcher makes a review of the different types of flexibility. Ten types involve: process flexibility, or produced with different types of process; material handling flexibility; machine flexibility, which means a single set up is used for different operations; operation flexibility; product flexibility, related with the variation mix of production; routing flexibility; volume flexibility, or variation in the volume of production; expansion flexibility, which is related with the capacity of production; production flexibility, and control program flexibility (G. Manu, 2018).

A few reasons for the need for a flexible manufacturing system are increased competition at the international platform, to achieve improved market response, reduced production time or reduced cost incurred.

2.3.3 Efficiency

A basic definition of this term is underlined by Zhan (2019): 'Efficiency means doing things right'. He, also, adds that this term is conceptualized as how efficiently the number of input resources is transformed into the number of outputs.

Moreover, to go further and give a more detailed explanation, Hanns de la Fuente-Mella (2019) describes efficiency as the combination of technical efficiency and allocative efficiency. On one hand, the term technical efficiency is introduced and involves maximizing the level of outputs that can be obtained from a given combination of inputs. This term indicates the degree of success in the use of productive resources. Hence, inefficiency is simply the difference between the observed values of production and the maximum achievable values are given a certain technology. On the other hand, allocative efficiency reflects the ability of a firm to use inputs in optimal proportions, depending on their respective prices.

3. First Systematic Literature Review on technology

The first research question of this Master Thesis is: Which is the suitable technology for automating the material handling system in a food industry facility which its layout is already fixed?

To answer to this research question, a systematic literature review has been carried out.

3.1 Methodology

Tranfield (2003) describes the term of the Systematic reviews explaining that they differ from traditional narrative reviews by adopting a replicable, scientific and transparent process, in other words, a detailed technology, that aims to minimize bias through exhaustive literature searches of published and unpublished studies and by providing an audit trail of the reviewers' decisions, procedures, and conclusions.

In addition, this definition can be completed with Ringsberg (2014) who introduces in his methodology section the definition of a literature review as “a systematic, explicit, and reproducible design for identifying, evaluating, and interpreting the existing body of recorded documents”.

Following the instructions of Tranfield (2003), the systematic review has a defined structure. This structure is divided into three sections:

- ‘Planning’. The initial stages of systematic reviews may be an iterative process of definition, clarification, and refinement. Within management, it will be necessary to conduct scoping studies to assess the relevance and size of the literature and to delimit the subject area or topic. Such studies need to consider cross-disciplinary perspectives and alternative ways in which a research topic has previously been tackled. The scoping study also includes a brief overview of the theoretical, practical, and methodological history debates surrounding the field and sub-fields of study. Where fields comprise semi-independent and autonomous sub-fields, then this process may prove difficult and the researcher is likely to struggle with the volume of information and the creation of transdisciplinary understanding (D. Tranfield, 2003).

In other words, in the first stage, it is identified the underlying reasons for a systematic review of collaborative forecasting problems among partners in the FSC. This may be further detailed in the form of research questions. Then, a proposal should be developed for the review along with a review protocol (C. Eksoz, 2014).

- ‘Conducting’. A systematic search begins with the identification of keywords and searches terms, which are built from the scoping study and literature. The search strategy should be reported in detail to ensure that the search could be replicated (D. Tranfield, 2003). Eksoz (2014) adds that the review protocol focused on identifying and selecting articles, assessing their relevance, and extracting unrelated sources along with completing the synthesis process. The exclusion criteria are linked to the desire to base reviews on the best-quality evidence (D. Tranfield, 2003). Ringsberg (2014) details more this section. He adds four steps: material collection or

delimitation and definition of material, where the information sources, the time frame, and keywords are selected and the exclusion criteria are defined and applied; descriptive analysis or predefined characteristics in the research material that provided a background to the theoretical analysis, where the papers are analyzed and the output should be a chart with a general classification based on all the characteristics found related with the topic; dimension and category selection or structural dimension and the analytic categories selected to structure the research field in the literature review; and material evaluation or the analysis and storing of material according to selected dimensions and main analytic categories to identify and interpret significant results.

The outputs of the information search should be the exclusion criteria for the search, a full listing of articles and papers on which the review will be based (D. Tranfield, 2003) (H Ringsberg, 2014), and a chart with the categories selected (H. Ringsberg, 2014).

- 'Reporting' where the findings are reported along pointing out the conclusions (C. Eksoz, 2014).

The output in this section should be the answer to the research questions.

The development of the first research question will follow Tranfield's structure. However, the first step is 'planning' where the background is analyzed and the output is the definition of the research questions. With the answer to these questions, the paper wants to provide more interesting consideration about the topic so it can be developed. This has already made in the first and second sections of the paper. Hence, the next step is conducting.

In this section, it is going to follow the four steps that Ringsberg (2014) describes:

3.1.1 Search Strategy

The main information source was Scopus. This source has been selected due to the wide variety of papers upload in its portal web, the reliability of the source, its friendly design which makes the research activity easier, and the free access offered as an NTNU student.

Secondly, the keywords used are related to the research questions. It has been selected four keywords: Autonomous, Mobile, Robot, and Material handling. Despite the simplicity of the word choice, the reasons for this combination are that they are the technology investigated, they are generic words that can gather all the alternatives that this investigation is looking for, and also, they do not scope around any specific industry. This last statement is due to if the papers were restricted to the food industry, Scopus would not have found any paper.

Thirdly, the time frame selected was, at a first approach, the last five years from 2015 till 2020. This time frame was reformulated from 2010 till 2020 due to the need for more inputs at the research. This change in the time frame selection will take into consideration the conclusions.

To complete the exclusion criteria chart, the research is going to limit the investigation to the papers classified as articles and reviews, excluding the conference papers. With these criteria,

the accuracy will increase (D. Tranfield, 2003). Furthermore, the paper selection will be limited by the English language due to facilitate the reading to the author.

Applying all these constraints, the amount of papers found for the research conforms to a total of twenty papers. At this stage, the exclusion criteria continue with a first approach based on the abstract and a second approach limited by the access constraints. After this material analysis, the total number decrease to seventeen papers.

To sum up the exclusion criteria, all the limitations and constraints explained before gather at the following chart. This chart has the objective that the readers can understand easily the method followed:

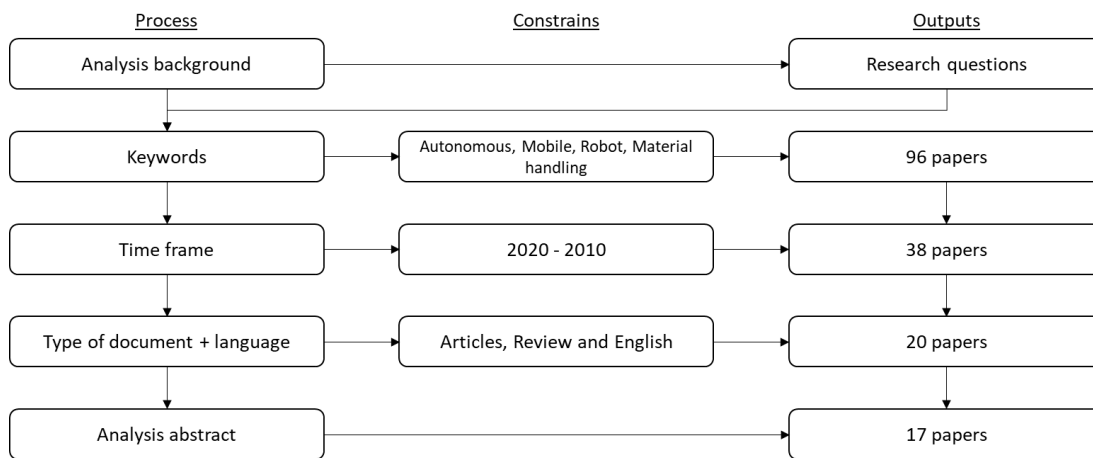

Image 4 Systematic literature review method

3.1.2 Descriptive analysis

Analyzing the papers, it is observed the common topic that gathers all the different investigations. They all agree in the future of the industry evolution becomes by the hand of new autonomous and automatized solutions. In the modern era, to lower the burden of labor on mankind effortlessly, physical tasks are being performed by machines which were considered to be done by humans in the past (F. Gull, 2019). Most of these tasks are involved in the material handling system such as picking, packing, palletizing, moving material from one station to another, and so on. Moreover, a large percentage of traditional manufacturing is undergoing organizational transformation and technology investment that make factories smarter and more efficient due to the global technology shift, the worldwide competition, and the demands of product variety (N. Hornáková, 2019).

Smart technology in industry and logistics is a relatively new concept that entered the market in the last few years (N. Hornáková, 2019). Even though this concept is quite new, automation has long been a part of material handling and goods logistics. At the latest, about 700 companies demonstrated how automation is playing an ever-increasing role in material handling (R. Bloss, 2011).

Also, the impact of the material handling system on the production cost and the final configuration of the layout has been emphasized by many authors. Some of them stated that

almost half of the total manufacturing cost is attributed to material handling costs (A. S. Tubaileh, 2014).

According to the first statement about the common topic of the papers. The technology stride is pointing to new solutions that meet up the new demand for flexible and reconfigurable material flows. The reason behind this new demand is explained by Herrero (2013). He affirms that this change in the customer requirements is due to the necessity of the ability to process or produce different products and allow rapid changes between them and to handle the uncertainty in product demand knowledge, finite manufacturing capacity, and random machine failures. Also, aligned with the tendency of technology, the use of mobile robots in industrial applications is growing on popularity. The use of robotic rather than human workers has enabled the automotive industry to ensure that tasks are performed according to expectations. Robotic workers are superior to human workers in areas such as speed and accuracy. Furthermore, human workers are limited to the number of hours they are allowed to work or the maximum loads they are allowed to handle or are capable of handling. (T. Ferreira, 2016).

Moreover, the need for flexibility and new technological solutions are support by other authors. D. Herrero (2013) highlights that “a wide spectrum of industry demands material handling systems that allow flexibly reconfigure automation processes without reducing their availability” and creating a tremendous impact in efficiency, productivity, and reducing costs. In this scenario, where the material flows are reconfigured flexibly, machines are normally arranged in single or multirow layout patterns. These layout configurations provide efficient operation of the material handling systems as automated guided vehicles or a mobile robot (A. S. Tubaileh, 2014).

Furthermore, getting close to the solutions suggested in the different papers, automated or autonomous robots lead the investigations. It is analyzed that automated guided vehicle systems are amongst the most flexible material handling equipment in manufacturing. They are used in various domains, from mail distribution to part transportation in heavy industry. The actual implementations of such systems have increased rapidly in the past decade, particularly in Europe and Asia. The implementations show effectiveness in different areas such as transportation, health care, logistics, etc. Several issues must be addressed in the setting up of an automated guided vehicle system (H. Fazlollahtabar, 2015). The main issues recorded in the paper selection are the obstacle avoidance and the recalculation of a new route due to some planning changes.

Most of the papers suggest ‘autonomy’ as the solution for facing these issues. The autonomous mobile robots are introduced as an alternative that can be suitable for every layout without any facility modification.

Despite all the information given about the different autonomous robots and how they can improve efficiency as a material handling system, most of the papers are investigations about how to improve them and how to make them more suitable to the different scenarios. This means, that the evolution still in process and there is room for improvements such as autonomous navigation which has been the main topic in the research read or extra structures that add more functionalities to the robots, such as picking products with a robotic arm.

3.1.3 Category selection

After the review of all the information given by the paper selection, it can be concluded that the most relevant information can be categorized into six groups of information: industry

implementation, technological solution investigated, guiding methodology used, reason for implementation, benefits of the solution, and limitations of the solution.

With these categories, the information will be analyzed more accurate in the following section.

3.2 Results of the first literature review

The information gathers by the table 1 will be analyzed divided in each category.

3.2.1 Industry

C. Wang (2016) highlights that the usage of an intelligent robot with independent capability is mainly made by manufacturing due to the high level of repetitiveness task and high level of possible standardization. However, in the last decades, this usage has been gradually extended to non-manufacturing. In particular, M. Bonini (2015) underlines that the activities associated with material handling systems are also repetitive and need high accuracy for avoiding damages or errors, which triggers the opportunity of robot implementation. Besides, if efficiency and efficient are added as requirements, the robots are more suitable for carrying these activities (M. Bonini, 2015).

M. Faisal (2018) concludes from his investigation that mobile robots will be responsible for several tasks that right now are carried by humans, some examples will be warehouse management, packet distribution and arrangement, product handling inside stockrooms, and in working inaccessible but dangerous sites.

Besides, H Fazlollahtabar (2015) underlines that the application of this new technology solution can be extended not only through the manufacturing industry but to the different types of industry including services. The examples given in this investigation are transportation, health care, logistics, and so on.

However, in the paper selection, there is none reference to the food industry. The investigations related to material handling, new technology solutions, and the food industry explained before in the 'Background' section can conclude that the robots are integrated into the production line in the operational tasks and maybe in some material handling basic activities as picking and packing.

Analyzing all the statements, there are two ideas:

- Autonomous mobile robots as a material handling solution can be applied in any type of industry with some exceptions based on the company requirements. In this statement, the food industry is included without hesitation. However, the success or not of the implementation should be analyzed at the end of the investigation.
- The lack of study in the implementation of autonomous mobile robots in the food industry is the objective of this investigation and the contribution to Academia and following researchers.

It is necessary to underline that the implementation of mobile robots depends on the company requirements more than the type of industry. This means that the main constraints are limited by the company facilities, objectives, possibility of investment, characteristics of the product, service level, and so on.

Article	Industry	Technology	Guiding Methodology	Reasons Implementation	Benefits	Limitations
AHP method application in the selection of appropriate material handling equipment in selected industrial enterprise	Industrial enterprise	Autonomous Mobile Robot (AMR)	Camera guiding	Increase production volume, optimization, and improvement of post-production handling process	Flexibility, versatility, not alteration of the existing environment, autonomy	Investment
A comprehensive study for robot navigation techniques	Transportation, rescue activities	AMR	Camera guiding	--	--	Program and design the obstacles avoidance and path following
A Prototype Smart Materials Warehouse Application Implemented using Custom Mobile Robots and Open Source Vision Technology Developed using EmguCV	Warehouse	Automated guided vehicles (AGV)	Inductive guided	Add flexibility to production, growth of the demand	Costs reduce, promote safety, agile and flexible	If the robot cannot deal with a situation, it calls the supervisor
Pathfinder Development of Automated Guided Vehicle for Hospital Logistics	Hospital	Autonomous Guided Vehicle	Camera guiding	--	Avoid obstacles, deal with dynamic environment, safety	--
Automation meets logistics at the Promat Show and demonstrates faster packing and order filling	Warehouse, Manufacture	Stationary and mobile robots for picking and packing. Conveyors. Palletizers, self-guided robotic with picking application	Laser guiding	Increase productivity rate	Autonomous decisions, cooperation with human operators	Customized for every characteristic and special need of the line production
Human Expertise in Mobile Robot Navigation	warehouse, distribution, dangerous sites	ARM	Camera guiding	Industry requirements more complex	Flexible to complex and unknown environments	Program and design the obstacles avoidance and path following

Layout of flexible manufacturing systems based on kinematic constraints of the autonomous material handling system	Manufacture Factories	AGV	--	In the layout design, the material handling system and activities need to be taken into account	Mobile Robots can face continuous curvature smoothly and safely	The fixed path
Development Of An Automated Guided Vehicle Controller Using A Model-Based Systems Engineering Approach	Industrial and logistic enterprise	AGV	Inductive guiding	--	Reduce cost, Robots are more accuracy and fast than operators, safety, improved production efficiency, flexibility, continuous operation for 16 hours	--
Ease of programming and sophisticated sensors see robots advancing in transport logistics, palletizing, order picking, and assembly	Manufacturing parts replenishment, hospital logistics, warehouse product movement	Forklift, self-contained transport	Inductive/camera guiding	--	No need for facility modification	Battery recharging
Mathematical model for deadlock resolution in multiple AGV scheduling and routing network: a case study	Manufacture, transportation, health care, logistics	AGV	Inductive/optical guiding	--	Lower labor costs than manual delivery methods, improved delivery speed, and reliability reduced injuries and compensations claims, increased payload delivery potential over manual lifting and transporting	Space limitations, planning routes for multiple robots
Bi-directional navigation intent communication using spatial augmented reality and eye-tracking glasses for improved safety in human-robot interaction	--	AGV forklift	--	--	Safety, efficiency	---

Multi-sensors multi-baseline mapping system for mobile robot using stereovision camera and laser-range device	Warehouse, rescue activities, manufacture	Autonomous Robots	Comparison of different sensors for guiding	--	Real-time map build on accurate, real-time data for mobile robots	Obstacles avoidance, autonomous navigation
Robotized and Automated Warehouse Systems: Review and Recent Developments	Warehouse	Automated Robotic picking systems	--	Saving space, reduce labor costs, demand variability	Flexibility, availability	Lack of study in the picking with AGV's
Self-Configuration of waypoints for Docking Maneuvers of Flexible Automated Guided Vehicles	Manufacture	Robotic forklifts, Autonomous AGV	--	Flexible material flow	Adapt to layout modification, plan alternative routes, productivity rate increase	Error positions
Scheduling of smart intra – factory material supply operations using mobile robots	Manufacture	AGV	--	Increase efficient, growth of demand	Autonomous decisions, decrease the error	--
Trajectory optimization for autonomous mobile robots in ITER	Energy engineering industry	AMR	Camera guiding	Need for moving heavy materials in high volume	Hazard environments	Optimizing routes
Modified crash-minimization path designing approach for autonomous material handling robot	--	Autonomous Robots	Camera guiding	--	Increasing production rate, maximum utilization of available resources, machinery, reduction of tool and material handling time minimization of manufacturing lead time	Path planning: complex environment surroundings and implementation on the field

Table 1 Articles Selection

3.2.2 Technology investigated

In the paper selection, it can be observed that the technology applied is diverse. In particular, there is a broad range of mobile robots implemented. The principal solutions are automated guided vehicles, autonomous mobile robots or autonomous guided vehicles, and some picking stationary robots. Most of the papers are focused on the two first types.

Hornáková (2019) introduces the definition and difference between these two types of technology.

Automated guided vehicles (AGV) are a mature technology that can safely transport payloads ranging from several Kg to multiple tons, essentially acting as semi-rigid distributed conveyor belts covering large areas. Nowadays, there is a wide range of options available with different technologies such as laser, magnetic tape, or wire guidance. However, it is a technological solution that requires modification of the infrastructure or facilities for installing the guidance.

Autonomous mobile robots (AMR) are radically different although AMR will ultimately enable automation to largely keep the flexibility and versatility of human-operated vehicles. AMRs use computer-based vision systems to navigate through their environment without guidance. This type of robot is free to roam and perform tasks anywhere in the facility.

Also, Hornáková (2019) draws a chart with a comparison between both solutions:

	AGV	AMR
Navigation	Infrastructure: wire guidance, reflective markers, Radio frequency ID, etc.	Trackless navigation. All sensing is done on-board. Senses the environment in a live fashion
Obstacles	Obstacles stop an AGV	Goes around obstacles and finds what the best path is according to its internal map
Flexibility	New tracks and infrastructure to be installed	Easily be remapped and taught new destinations and goals
Expandability	Possible to add new tracks and new units to it	Everything is managed on a fleet software package
Charging	Docking Station	Docking Station

Image 5 Characteristics AVG and ARM (N. Hornáková 2019)

Even though the AMR provides a higher level of flexibility, as it is not a mature technology, the AGV has been implemented in more industries.

However, all the future works which are related to the AGV suggest that the next steps should provide autonomy to the robot.

3.2.3 Reasons implementation

Some of the papers are possible implementations in the real industry, some of them are real implementations and the rest are investigations related to improving characteristics, or introducing the different models available in the market.

The real or possible real cases have their reasons and are already written in table 1. For not being redundant, the two more common reasons are a change in customers' demand and looking for efficiency.

Furthermore, the change in customers' demand is due to a growth in the demand (D. Culler, 2016) or a growth of the product portfolio. Either growth requires a flexible system (S. Pattanayak, 2019).

Therefore, the principal idea is that mobile robots can support industry changes due to their flexible characteristics. Furthermore, as was explained before, the food industry requirements

3. First Systematic Literature Review

have changed turning over more responsiveness, flexibility, and efficiency (A. Romsdal, 2014). Hence, the implementation of mobile robots in the food industry maybe can contribute to better performance.

3.2.4 Benefits

Even though all the benefits are listed in the table 1, this section will highlight the principal ones of the automated and autonomous in separated ways.

Automated	Autonomous
Flexibility	Flexibility
--	No need of facility/infrastructure modification
Stop for avoiding collisions	Deal with dynamic environments. It can recalculate the routes, avoid obstacles
Promote safety	Promote safety
Increase productivity rate, efficient and efficiency	Increase productivity rate, efficient and efficiency
Reduce cost (labor)	Reduce cost (labor)
Availability for several shifts	Availability for several shifts

Table 2 Benefits comparison between AVG and ARM

3.2.5 Limitations

Following the same structures as the last section, the limitations can be gathered at the next chart:

Automated	Autonomous
Need supervision of operators	--
Need to be customized for the implementation (design, dimensions, protocol interaction with the system,...)	Need to be customized for the implementation (design, dimensions, protocol interaction with the system,...)
Fixed path, no option to alterate it	Complex programming to find alternative paths, avoid obstacles, find the shortest distance
Need of facility/infrastructure modification	--
Need time for battery recharging	Need time for battery recharging
Planning and coordination routes for multiple robots	Planning and coordination routes for multiple robots
--	Investment

Table 3 Limitation comparison between AVG and ARM

3.2.6 Guiding methodology

Even though, it can be some relationship between the technology and the guiding method, through this selection of papers it cannot be found a specific solution to which guiding method is better or worse for each type of technology.

However, all the guiding methods used were indeed based on the facility implemented, the functionality they need to perform, and the requirements of the company or the project.

These three characteristics will help to pick the automated technology solution for material handling in the food industry.

3.3 Conclusions

The purpose of this section is gather all the information collected by the papers selected for this literature review. There are three main ideas:

1. AMR vs AGV

According to every information explained in the development of the research, the autonomous mobile robots (AMR) is a technological solution for material handling system which offers flexibility and versatility to the material and information flow within a company. This flexibility is understood as the capability of a system to withstand any modification in the planning production due to the variability of the customers' demand or other market factors. This can be provided by AMR due to its capability of adapting to dynamic systems where the layout is not always set up the same or operators or other robots are moving around it. This means that the AMR doesn't need to follow any guidance because it can calculate its path and recalculated if there is an obstacle or a new planning order. This is possible thanks to their intelligent processor and its camera that provides real-time mapping of the facilities. Moreover, as the AMR doesn't need any input for working, the facilities or infrastructure, where it is operating, doesn't need to be changed.

Besides, the AMR will support all the repetitive and non-value added activities, the efficient of the company will be improved. Furthermore, the robots have a long battery life, so they can work through several shifts without being recharged. Consequently, the costs are reduced, and the productivity rate increase.

However, this technology is not mature enough due to the lack of investigation done. Moreover, the investigations are aligned reaching a better algorithm for the recalculation route and better coordination between multiple robots working in parallel. Furthermore, the technology more developed and more used in the industry is the AGV. According to these statements, the investment needed is high but the experts ensure that the technology will be more affordable in the few next years (D. Culler 2016).

2. Food industry

As is already discussed through the investigation, the food industry has been robotized decades ago with the introduction of the robots for picking, packing, and palletizing. After this first robot, the process robots came. Hence, the food industry has room for robots.

Even though robots already exist in the food industry, nowadays the food industry is requiring more technological development to meet new customers' demands.

On one hand, all the papers selected relate the use of autonomous or automated mobile robots with an increase in flexibility in their manufacturing facilities and better performance in their service level as the hospital logistic case. They are sold as a solution for facing the demand variability, all the new characteristics demanded by the customers as new products or a fast

response, and, also, for giving a higher service level. On the other hand, any paper refers to the food industry or similar.

Therefore, taking into account all the information analyzed and all the background about food supply chain and its necessities, it can be concluded that the technological solution investigated, AMR and AGV is perfectly suitable for being implemented in the food supply chains at any echelon where a material handling system is needed. In particular, the papers point out that AMR is the future for material handling system solutions. However, this technology maybe not be suitable for every factory due to budget, functionality or the company specifications.

3. Navigation Method

This literature review was not a suitable investigation to conform to a critical idea of which type of navigation method is the most convenient one for the food industry.

It can be concluded that the navigation method should meet the company requirements and facility constraints.

It is needed another literature review more focus on this topic to understand the benefits and limitations of the different navigation methods for ARM and AGV.

4. Second Systematic Literature Review on technology

The literature review developed before was focused more on understanding the opportunities for automating the material handling system in the Food industry. The conclusion above explained that like other industries that have already introduced automated technology as a material handling solution, the food industry can benefit from the implementation of these solutions.

The only incomplete concept that is not solved with this literature review, is the suitable navigation method that can benefit the food industry in the case it exists one.

To answer the first research question showed at the beginning of this investigation, the author believes that another literature review is needed. In this second review, the method explains in the last section will be used again.

4.1 Methodology

4.1.1 Search Strategy

First of all, the main information source is Scopus.

Secondly, the keywords used are related to the research questions. It has been selected: Navigation Method and Mobile robots. This selection is made based on the result of the research, using more specific words as AGV or AMR or Material handling reduced the number of papers to less than five papers. This scenario would not have been enough for reaching a critical conclusion. In addition, to improve the accuracy, the subject area will be scope to “Engineering”.

Thirdly, the time frame selected was the same as the last literature review, from 2015 to 2020.

To complete the exclusion criteria chart, the research is going to limit the investigation to the papers classified as articles and reviews, excluding the conference papers. With these criteria, the accuracy will increase (D. Tranfield, 2003). Furthermore, the paper selection will be limited by the English language due to facilitate the reading to the author.

Applying all these constraints, the amount of papers found for the research conforms to a total of 35 papers. At this stage, the exclusion criteria continue with a first approach based on the abstract and a second approach limited by the access constraints. After this material analysis, the total number decreases to 26 papers.

To sum up the exclusion criteria, all the limitations and constraints explained before gather at the following chart. This chart has the objective that the readers can understand easily the method followed:

4. Second Systematic Literature Review

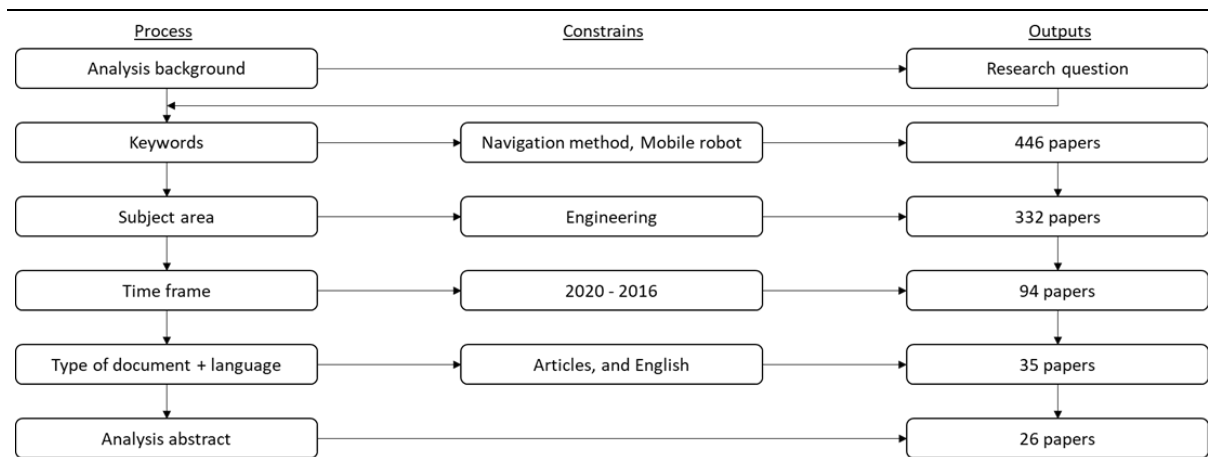

Image 6 Systematic literature review method

4.1.2 Category selection

Based on the research question made at the beginning of the investigation and the lack of information in the first literature review, this research is focused on the selection of the navigation method. Due to this aim, the information that is going to be collected from this selection of papers will be the type of navigation method, the type of robot used, the benefits and limitations highlighted about the navigation method used, if it can be implemented in a fixed layout, and if the paper is connecting a navigation method with an application of the robot. These will confirm the categories of the literature review.

4.2 Results of the second literature review

In this literature review, the information gathers by table 2 will be analyzed all together.

There is not a pattern or a clear stream of how the different navigation methods are assigned for one function or another. However, it is observable, that most of the methods in research are focused on visual methods based on the configuration of several cameras.

In addition, a high percentage of the papers use at their investigation AMR or they mentioned the words “autonomous navigation method”. This statement is aligned with the first literature review that supports the ARM as the next generation of material handling solutions. However, the research does not mention any particular example of AGVs. This can be considered a constraint for the critical conclusion but, also, brings the conclusion that if researches are pointing in the AMR direction, in a short future, the technology will evolve to AMR and the AGVs will not be suitable anymore.

However, AMR solutions are currently under investigation. The paper selection is more focused on new navigation methods and algorithms develop rather than the real application of the methods. This statement leads to the possibility of use AGVs due to is technology is known, trustful, and used nowadays in the manufacturing industry.

Article	Navigation Method	Robot use	Benefits	Limitations	Fixed layout?	Application
RFID Based Navigation System for Indoor Mobile Robots	landmarks (RFID tags) + laser	MR	Cheap, adaptable to every facility already fixed, the RFID tags doesn't need a power supply	Needs a wall to have a reference to be guided, a lot of RFID tags around the facility, needs a extra system to get localisation information	yes	not especified
Implementation of RFID Robotics Based Vehicle Real Time Navigation System	Vision-guided + landmarks (RFID tags)	MR	ideal for indoor environment, obstacle avoidance (dynamic atmosphere)	needs a GPS/GPRS for an accurate localisation information, expensive	yes	not especified
Mobile robot indoor dual Kalman filter localisation based on inertial measurement and stereo vision	Stereo vision (guided by QR readers, as landmarks) + inertial navigation	MR		error at localisation information, need of filters and GPS to improve		
Visual navigation method for indoor mobile robot based on extended BoW model	recognition of natural landmark	MR		in process of investigation, no need of tags or other system to understand the environment	yes	not specified
A hand-drawn map-based navigation method for mobile robots using objectness measure	visual navigation + hand drawn map	MR	not precise distance information, not use of gps for localisation	The path needs the approval of an operator, current investigating	yes	not specified
A hybrid approach for autonomous navigation of mobile robots in partially-known environments	visual navigation + near-time-optimal trajectory-planning method + path-planning method	AMR	not precise localisation information, reduce memory requirements,	miss the presence of unexpected obstacles encountered while tracking a reference trajectory	yes	not specified
A novel fuzzy three-dimensional grid navigation method for mobile robots	grid map-based navigation methods	MR	self-navigation while reducing the resources cost and promoting the running efficiency and speed	complex design/calculations	yes	not specified

Formation experiment with heading angle reference using sky polarization pattern at twilight	polarization navigation sensor	AMR	no error accumulation, low range of error	design for outdoors, current investigation		not specified
A Single RF Emitter-Based Indoor Navigation Method for Autonomous Service Robots	RF-based localisation (using antennas)	AMR	no need of gps, cheap,	difficult calculations in complex environments	yes	not specified
Autonomous Dam Surveillance Robot System Based on Multi-Sensor Fusion	grid map-based navigation methods + gps	AMR	assign risk task, agile	for improving the localization information use laser and odometry wheels	yes	dam surveillance
Autonomous navigation using received signal strength and bearing-only pseudogradient interpolation	Wireless sensor network navigation system	AMR	minimize the overall trajectory by utilizing the inter-node space	sophisticated hardware, complex algorithms, limit number of sensors, obstacle avoidance	yes	not specified
Deep-Learning-Based Pedestrian Inertial Navigation: Methods, Data Set, and On-Device Inference	inertial navigation	MR	simple infrastructure, insensitive to environmental dynamics	current investigation, need of a lot of sensors	yes	not specified
Homing with stereovision	Visual homing (algorithm) navigation	AMR	map is not necessary, localisation not necessary	not in long distance navigation		not specified
Interval Type-2 Neural Fuzzy Controller-Based Navigation of Cooperative Load-Carrying Mobile Robots in Unknown Environments	Visual navigation	MR	adaptable to dynamic environments	proposition for two robots collaborating together (cooperative load-carrying), complex, needs a guidance reference (wall)	yes	carrying load
Machine vision and fuzzy logic-based navigation control of a goal-oriented mobile robot	vision-based deliberative control approach into a behavior-based control architecture	AMR	achieve the goal avoiding obstacles	needs complex algorithms to improve accuracy	yes	not specified
MGRO Recognition Algorithm-Based Artificial Potential Field for Mobile Robot Navigation	Ostu threshold segmentation method (MGRO) for the navigation of mobile robots with visual sensors	MR	avoid obstacles	processing time, needs filters due to the noise	yes	not specified

Multi-sensors multi-baseline mapping system for mobile robot using stereovision camera and laser-range device	stereo vision and laser method	AMR	build 3D map, dynamic environments	laser only to localisation information	yes	housework, security patrolling, search-and-rescue operations, material handling, manufacturing, or automated transportation systems
Navigation Algorithm Using Fuzzy Control Method in Mobile Robotics	odometry navigation method	MR		needs a control algorithm		not specified
Teaching-Playback Navigation Without a Consistent Map	teaching-playback navigation method (visual navigation)	AMR	teaching-playback autonomous navigation can be achieved without any off-line processes, obstacle avoidance, not require a consistent map built	needs excellent SLAM techniques, a lot of data	yes	not specified
Path Navigation For Indoor Robot With Q-Learning	Q-learning based path navigation method	AMR	smooth collision avoidance	fixed path, the robot needs to be trained everytime the layout changes	yes	not specified
An effective depth map navigation for mobile robot in indoor environments	visual navigation method + kinect sensors	AMR	avoid obstacles, not need localisation information	extra depth camera to improve precision	yes	not specified
Road area detection method based on DBNN for robot navigation using single camera in outdoor environments	vision-based navigation system + neural network	MR	detection of obstacles outdoors	needs a guidance reference, not all the types of roads are detected		wheel chair
Robotic Path Planning Based on Episodic-cognitive Map	episodic-cognitive map based navigation	AMR	dynamic environments, reduce processing time	needs visual and odometry methods, time for processing map	yes	not specified

Seamless autonomous navigation based on the motion constraint of the mobile robot	motion constraint navigation system (gyroscop, magnetic sensor, satellite receptor)	MR	good results without GPS signal, cheap	current investigation	yes	not specfied
Study of the Navigation Method for a Snake Robot Based on the Kinematics Model with MEMS IMU	inertial measurement unit navigation method	MR	good results, precision	current investigation, only outdoors, not application for industry yet, only short distance	no	none
Toward evaluation of visual navigation algorithms on RGB-D data from the first- and second-generation Kinect	visual navigation method + kinect sensors	MR	precision	needs cameras all across the ceeling	yes	not specified

Table 4 Articles Selection

Moreover, the benefits and limitations categories are full of different concepts. The principal ones are that the navigation method works better indoors with limited space, that they require algorithms for improving the accuracy of position, direction, and obstacle avoidance. Furthermore, the use of cameras, visual navigation method, is the most investigated method. This method has the inconvenience of the price due to cameras are not cheap devices.

The rest of the methods investigated in the papers selected proposed are the inductive guidance based on magnet tags around the facility or the visual method with different sensors that improve the precision. Both alternatives are cheaper than a set of cameras as the visual navigation method. The magnet tags are easy to implement and do not need energy, even though the accuracy is not the highest one. The alternative of using the visual navigation method with different sensors such as laser or odometry sensors reduced the price of the robot and increase the quality of the localization information and the performance creating and following paths.

Besides, all the robots investigated are defined as autonomous or characterized by their autonomous navigation method. Either way, the AMR has the characteristic of flexibility and adaptability to any facility. This means that all of them can be implemented in a facility where the layout is already fixed. The information that it was expected to find was more related to the AGVs which depending on the guided method they adapt better to a fixed layout or not. For example, the mechanical guidance implies digging the floor and built a mechanical path around the facility. This alternative cannot be considered as adaptable to fixed layout as optical guidance which only needs to add a colorful tape to create the path.

Finally, the last category aimed to relate a navigation method with a robot application. It did not give any type of information due to all the papers where more focused on develop the algorithms of precision and try them rather than a real case implementation.

4.3 Conclusion

The purpose of this section is to answer the first research question with all the information gather by the first and second literature review.

RQ1. Which is the suitable technology for automating the material handling system in a food industry facility which its layout is already fixed?

Firstly, the food industry is opened to every opportunity of technology development to improve its performance as the rest of the industries. In the first literature review, it was observed that the researchers highlight that the automated material handling system used in the food industry was focused on simple activities of packaging and palletizing. Hence, it is found an opportunity to improved and to introduced the benefits of the technology to this industry.

Secondly, nowadays, the technology implemented as a material handling system in the industry is AGVs. However, the AMR is getting more relevance day by day and all the investigations are focused on its advance and development. This leads to understanding both solutions as good alternatives but, if other factors as prize or flexibility or functionality do not count, the AMR alternative has a better future projection.

Thirdly, the navigation method has not a clear relation to robot functionality. This allows the company to choose a broad range of possibilities. However, the visual navigation method with or without other sensors has been the principal investigation for the last 5 years.

Fourthly, the company's choice of material handling solution needs to take into account their requirements and applications they looked for. This means, that even though there is no relation between navigation method and application, not every method meets the company's needs. The decision should take into consideration the company's requirements and its facility's constraints. In particular, in this investigation, a solution for a layout already fixed is been searching. The constraints are that the implementation should not request for changing the layout or rebuilding the facility. The navigation method examples that meet these limitations can be optical, magnetic, or visual guidance. The two first examples are related to AGVs and the visual guidance with cameras is connected to autonomous navigation.

All things considered, there is a clear opportunity of automating the material handling system in a food industry facility which its layout is already fixed, even though there is not an exact perfect navigation method for the investigated scenario. The choice needs to be done taken into account the requirements and constraints of the company, and, also, the task given to the robot.

5. Case study

The purpose of completing the investigation with a real case is to provide more preciseness to the research and a better understanding of the topic. It is expected that the conclusions obtained with the literature reviews above bring enough knowledge to understand better the problem and requirements of the company.

The development of this case will rise up the answer of the second research question of the Master Thesis: Which is the best solution for automating the material handling system in Company X?

This case study will be solved by a simulation methodology. Simulation is described as the imitation of the operation of a real-world process or system over the time. Moreover, it is used to describe and analyze the behavior of a system, and aid in the design of real systems (J. Banks, 1998)

Hajjar (1996) explains that the simulation tool is conform by three steps: a pre-processor, a simulation algorithm and a post-processor. The first step's objective is to model the scenario. The simulation engine, the second step, performs the required analysis generating results and statistics to output files. Then, all this raw information provided by the simulation is going to be treated in the third step.

In this investigation, the most elaborated procedure is the first step, building the process, due to the second step is going to be performed by AutoMod tool and the analysis carried in the third step has simple data easy to evaluate with Excel.

Building the process gathers several data preparation and assumptions for creating the simulation design. This process can be divided as Hajjar (1996) shows:

- Preliminary conceptual design. In this step, it is needed to be defined the initial problem statement, the description of the processes and their relationships which will conform the simulation tool. It is important to highlight the variants, the sequence of events, the triggers of each event. At this point, the assumptions and constraints have to be determinate.
- Simulation level design. The simulation Tool is already design, so this step will only need to understand how the different events are related, when they start and finish, and which comes first. This step is the creation of the code that simulation tool is going to read.
- Data structure design. The simulation tool will read the code to generate the simulation, but first needs to understand what does it read. The data structure involves the definition of the data objects or classes that will represent the elements and processes of the tool.
- Preprocessor desing. This step is already built thanks to the use of AutoMod simulation Tool.

All this steps are going to be followed to design the simulation. However, the preliminary conceptual design needs to be completed with the theoretical calculation to understand the case study evaluated.

The following case study will follow this structure. The company is going to be introduced to understand the case. Following this introduction, the methodology of how the data is going to be treated is going to be explained. In this section, the first analysis of the Company data is focused on finding opportunities of improvement to select the unit of analysis. Afterwards, the data is going to be processed and analysis. The results of this analysis is going to be validated by a simulation which is going to hold a realistic representation of the production line during the last year. During the development of the study, the data, results and assumptions are going to be validated with the company.

5.1 Introduction

Company X is one of Norway's largest confectionery manufacturers. It operates within the segment of fast-moving consumer goods, such as chocolate, confectionery (sweets), and snacks (nuts and dried fruits). Moreover, its turnover is about 760 million NOK and there are about 220 employees.

Company X operates in all of the nordic countries. Norway, Sweden, Finland, and Denmark. It has one production facility, located in Fredrikstad, Norway, where the workup and manufacturing of nuts & snacks, chocolate and sweets are done.

Company X gather four brands: Brand 1, which serves candy, lollipops, pastilles, and mixed confectionery bags; Brand 2, which offers sugar-free pastilles with a wide range of flavors; Brand 3, which has a wide range of nut and dried fruit products; and Brand 4, which has been serving quality chocolate.

As is said, its product portfolio is divided into three categories: chocolate, sweets, and nuts. Each category gathers a wide variation of products not only different food products but also the different packages of the same product. In total, there are 127 finished products. Some of these finished products are elaborated with a mix of several intermediates products.

Category	Family type	Number of products
Sugar	Sugar 1	14
	Sugar 2	2
	Sugar 3	12
	Sugar 4	14
	Sugar 5	4
Chocolate	Choco 1	8
	Choco 2	6
	Choco 3	4
	Choco 4	1
	Choco 5	9
	Choco 6	3
	Choco 7	2
	Choco 8	11
Nuts		37

Table 5 Product Portfolio

This previous chart is a brief introduction of all the product portfolios, divided into the three categories and subdivided by family types. The selection of the family types is based on the material flow of each product. One family type gathers the products that follow the same material flow. This decision is made to facilitate the next analysis.

Every product category is also separated from each other in the facilities of the company due to avoid allergic issues. This means, three main areas divided the layout. This is complete with the office space and the several warehouses needed for storing raw and packaging material and intermediates and finished goods.

For a better understanding, the layout will be explained better with images with all the important points highlighted.

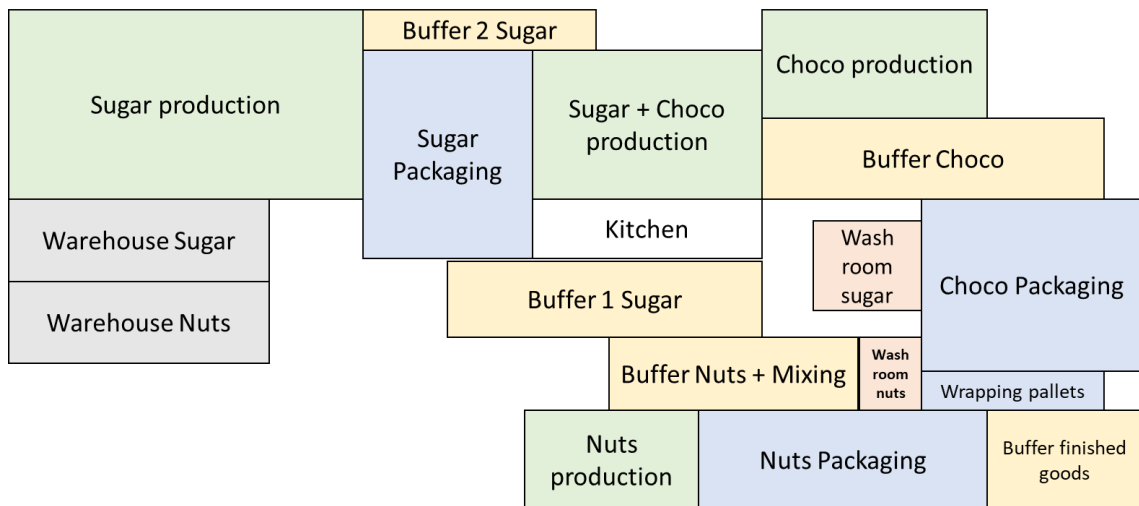

Image 7 Layout Company X

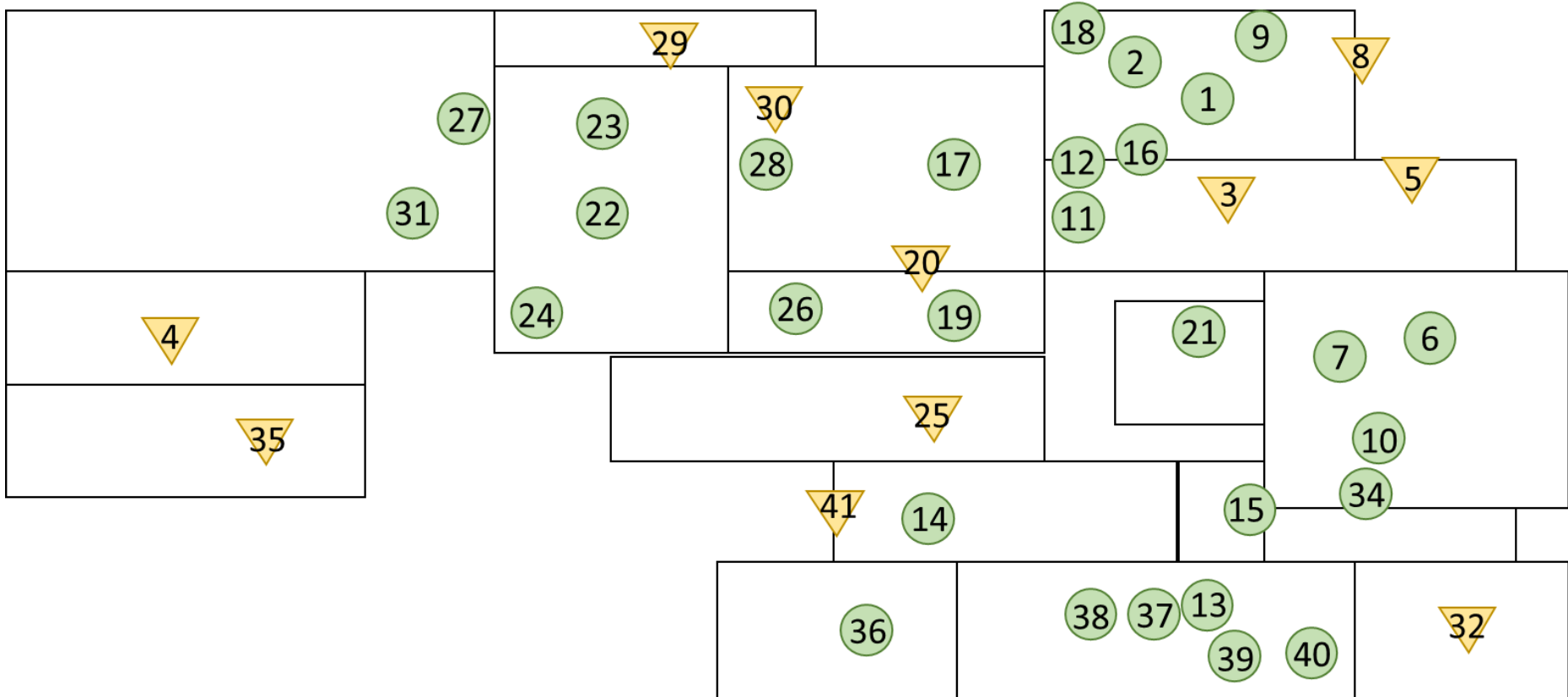

Image 8 Layout Company X

#	Name	14	ChocoProcess5	28	SugarProcess2
1	ChocoProcess1	15	Wash Nuts	29	SugarBuffer2
2	ChocoProcess2	16	ChocoProcess6	30	SugarBuffer3
3	ChocoBuffer1	17	ChocoProcess7	31	SugarProcess3
4	ChocoWarehouse	18	ChocoProcess8	32	BufferFinishedGoods
5	ChocoBuffer2	19	ChocoKitchen	33	ExternalWarehouse
6	ChocoPack1	20	ChocoBuffer4	34	Wrapping
7	ChocoPack2	21	Wash Sugar	35	NutsWarehouse
8	ChocoBuffer3	22	SugarPack1	36	NutsProcess
9	ChocoPack3	23	SugarPack2	37	NutsPack1
10	ChocoPack4	24	SugarPack3	38	NutsPack2
11	ChocoProcess3	25	SugarBuffer1	39	NutsPack3
12	ChocoProcess4	26	SugarKitchen	40	NutsPack4
13	ChocoPack5	27	SugarProcess1	41	NutsBuffer

Table 6 Layout Description Company X

As can be observed, the layout is divided into the three main areas already explained. Each area is divided into processed activities and packaging. Besides, every area has a buffer for intermediates products, trays, and pallets empty, and packaging and raw material which is going to be used in a short period. Moreover, each section has a washing area and a warehouse. In this last warehouse, raw material with a long shelf life and packaging material is stored. Furthermore, there is a reception area and delivery area for the logistical activities made by trucks.

For a confidential contract, not all the information provided will be shown in this thesis. This is the reason the following information is only about the sugar area which is the studied area. This choice of area for the research will be explained after the analysis of the material flow.

According to the information constraints, the following interesting information is the number of products processed in the company’s facilities:

Category	Family type	Production (tons per year)
Sugar	Sugar 1	1550,5
	Sugar 2	52,3
	Sugar 3	3613,8
	Sugar 4	2473,1
	Sugar 5	---

Table 7 Production (tons/week) of each family type

The product Sugar 5 is not going to be evaluated in this investigation due to is a mixed product between sugar area and chocolate area. Between both areas, there are several cleaning points to not contaminate one area with the products of the other area. This is the reason, a robot between areas will not be investigated.

5.2 Methodology

This case of study will be divided in three sections: analysis of the company and theoretical calculations, simulation and comparison cost chart.

5.2.1 Analysis of the company and theoretical calculations:

The purpose of this section relies on the necessity of understanding the Company, its flow material, its products, and its requirements.

For the first analysis, there are several approaches. Some of them can be considered global which includes every detail of the whole company including information and material flow, lead times, tack time, and so on. This kind of analysis is drawn in a map call Value Stream Mapping (VSM), introduced by the Lean Manufacturing philosophy and methodology to raise the rate of value-added operation to non-value added and waste (E. Jimenez 2012) (L. Chen 2010). Its objective is finding improvements in the Supply Chain or line production of a company. There is another analysis more local to the problem and focus only on one area of the company using fewer tools to understand the situation.

In the local approach, the Lean methodology offers diverse tools such as material flow map, spaghetti diagram, from-to chart, and so on (D. Falcone 2011).

The scope of this analysis only involves the path made by the raw materials until they are transformed into the finished products. In this analysis is needed the amount of material moving across the facilities and how much-finished product is delivered at the end of the line production. This material distribution inside the facility is done by the material handling system which is the main concern in this paper. In between the transportation of materials (raw material, intermediates products, packaging material, or finished products), other movements are needed to be taken into account such as the return of empty pallets or trays.

According to the necessities of the project, the suitable and selected tools are the material flow map and the spaghetti diagram.

The material flow map

The purpose of using this tool is to represent the material flow in a draw for a better understanding to find room for improvement (D. Falcone 2011).

However, before starting to map the material route, it is needed to understand the company, how it is structured, how many products are processed, how much is processed. The output of this first approach is a family product classification.

The first step for drawing this map is collecting all the company data about its line production that is related to the material flow. In this research, the information was collected in an arranged visit. The data collected was the path that each product made in its transformation, the amount of material moving per pallet, and per way, type of material handling system used, and the production planning.

For drawing the map, there is a standard code by ASME, where every element in the material flow has its figure (D. Falcone 2011).

The spaghetti diagram

This tool has been selected to support the information given by the material flow map. The purpose of using the spaghetti diagram is due to this diagram the material movements can be visualized (D. Falcone 2011).

For a better understanding, it is going to be used the same standard code than the material flow map.

Theoretical calculations

For the theoretical calculations, the methodology will follow the different tools and methods learned at the course “Industrial Logistics system design” imparted by Fabio Sgarbossa, Doctor at the Production Management Department at NTNU, Norway. The objective of this analysis is to calculate the theoretical number of robots that conform to the material handling system.

Firstly, the data provided by the company needs to be processed and selected aiming for the data necessary for understanding better the flow material and how many products are move from one station to another. This analysis result will be the number of pallets produced in the area of sugar at the company every day from March 2019 until February 2020.

Secondly, several scenarios will be defined to evaluate the different requirements and, after the analysis, can compare which is the most suitable alternative.

Thirdly, the information about the material flow will be gathered in a From-To Chart sort by the different scenarios.

Fourthly, the calculate the number of robots in each scenario.

5.2.2 Simulation

The simulation aims to check the theoretical result previously calculated, and provide an accuracy platform to understand the behavior of the solutions in each scenario.

The modeling of the data used for the simulation is based on the same data provided by the company. The simulation will reproduce the performance of the company facility in the sugar area during a year, in this case, they would have implemented robots as a material handling system.

For the simulation, the program that is going to be used is AutoMod, which provides a student license for free. It was the one recommended by the Supervisor of this thesis.

Furthermore, the student license has restrictions on the number of variables that can be created. This constrains triggers the necessity of formulating several assumptions. For example, the simulation will only represent the creation of pallets and the movement of these. This means, that the flow material will not be replicated exactly showing how the products are processing in each scenario. This assumption helps to reduce the number of variables needed without decreasing the accuracy of the simulation.

The process of how the simulation will be executed is the following:

1. Configuration of the layout. Place the different workstations, buffers, and warehouses that are taking part. Set up the paths that connect the workstations.

For this step, the layout provided by the company will be the reference.

1. Programming the different triggers for the production of pallets and movement of them.
2. Introduce at the code the possibility of reading a text file in which all the information of in which time every pallet is produced is gathered.
3. Simulate the different scenarios and collect information about the work in process (WIP), usage of the robots, capacity at the workstations' queue, and so on.

All this information will take an important role in the following section.

5.2.3 Comparison Cost Chart

The objective of this thesis is to answer the research questions wondering at the beginning of the investigation. The first research question was answered by the literature review. The second research question is going to be solved by the case of the study. A comprehensive method for evaluating the most suitable solution between the different alternatives studied is a comparison chart of all the scenarios. In particular, an objective option to compare these alternatives can be the cost incurred by each scenario.

The main costs to be considered are going to be those that can be different between one scenario and another due to the hours worked, the number of robots, the space needed, and so on. The reason behind this statement is that including all the costs of the company's performance will take time and the result will be the same.

The cost that is going to be included in this analysis will be:

1. Cost of the robots
2. Cost of the workforce needed to help the robot
3. Cost of the WIP
4. Cost of the space needed for the pallets waiting to be moved by the robots
5. Cost of the implementation (software, design path)

All the costs will be summed, and taking into account the average usage of the robot, the choice of the most suitable alternative will be done.

The criteria for evaluating the different possible scenarios will be supported by the results of the Comparison Cost Chart. The evaluation will analyze three main factors the total costs incurred, the percentage of the robot's usage, and the relation between these two factors.

The solution which is looking for should have one of the smallest incurred costs, a high usage percentage, and a high rate between the usage and the cost. This solution will be selected also by the conclusion at the end of the literature review. Taking into account the cost but, also, the technology more suitable to the company's facility.

5.3 Material Flow Mapping

As is explained in the methodology, the material flow mapping is a standardized process, where all the product's steps taken are recorded in a draw to understand the path of each product and seek improvement.

According to the information constraints, only the sugar area maps will be shown.

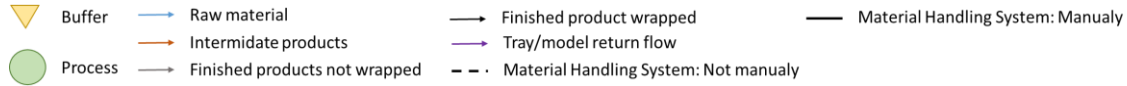

Image 9 Visual Legend

Family type: Sugar 1

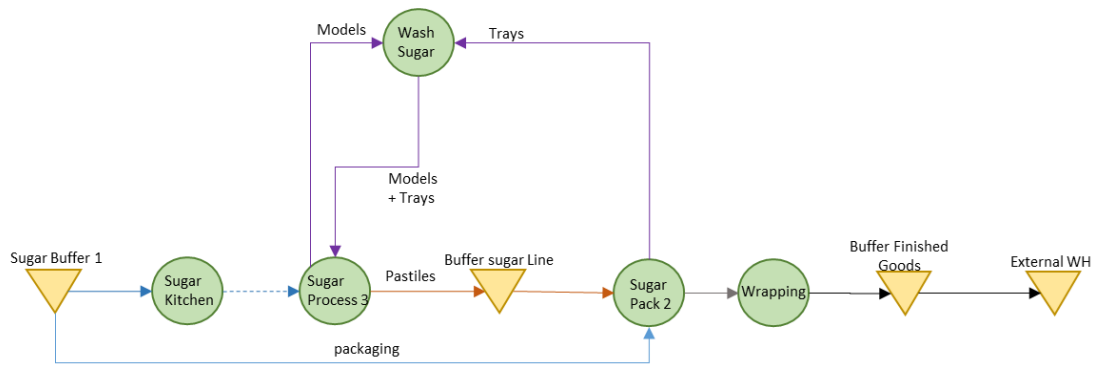

Image 10 Material Flow Sugar 1

Family type: Sugar 2

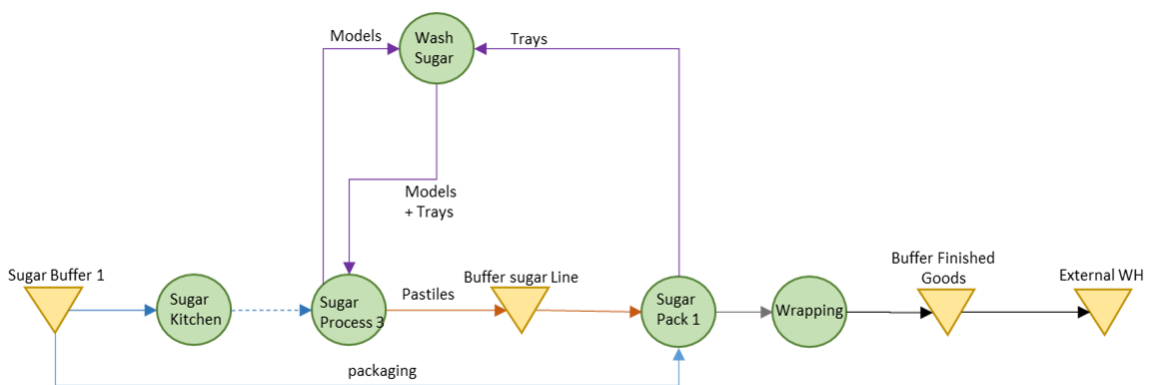

Image 11 Material Flow Sugar 2

Family type: Sugar 3

5. Case Study

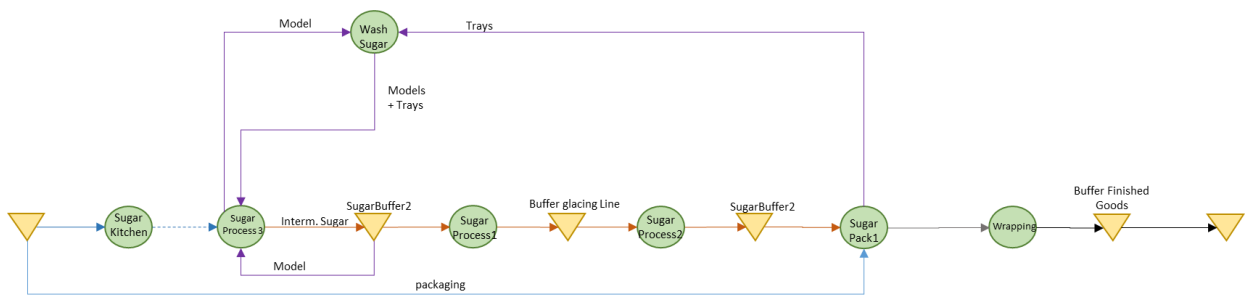

Image 12 Material Flow Sugar 3

Family type: Sugar 4

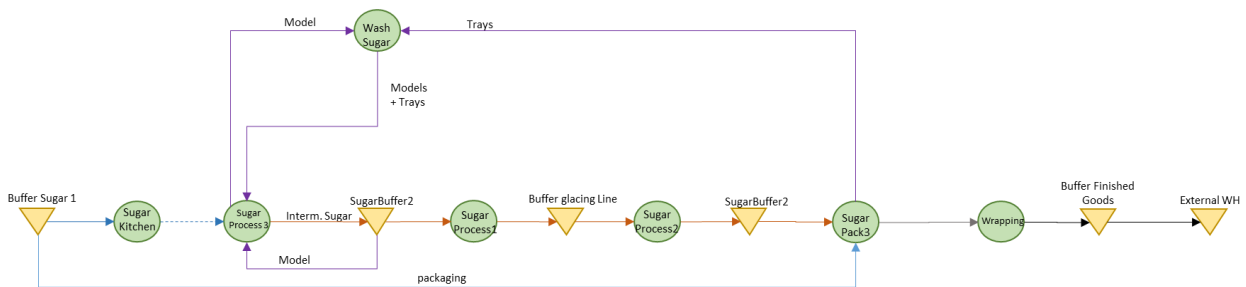

Image 13 Material Flow Sugar 4

5.4 The Spaghetti Diagram

The diagrams will be attach to the investigation at the next pages due to the configuration of the design.

Family type: Sugar 2

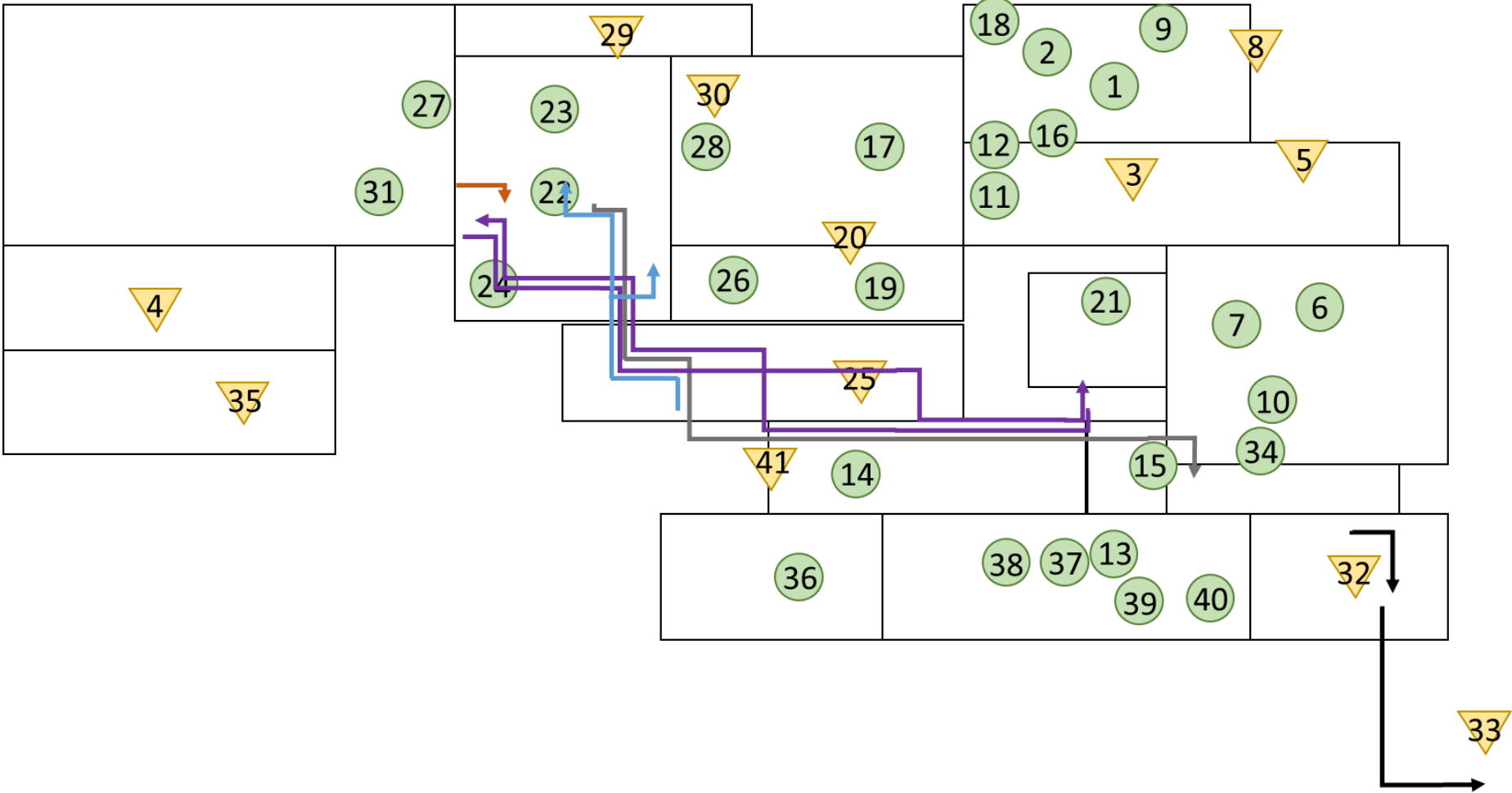

Image 15 Spaghetti diagram Sugar 2

The company fits with the description of the company profile this investigation is focused on. The process has a high level of robotization with autonomous robots that transforms the raw material into a finished packed product. Meanwhile, the material handling system is fulfilling with a lower level of automation such as pallet jacks for facilitating operators' work of the internal material transportations.

Besides, Company X has an already-built facility and well-divided due to the avoidance of food contamination. Moreover, there is no chance of layout extension because it has already built the allowed area. Furthermore, as it was underlined, the paths are narrow and with a lot of angles with a lot of obstacles in between, which does not allow a redesign or a modification of the infrastructure for implementing.

Furthermore, taking into account all the information that is gathered in the Material Flow mapping and the Spaghetti diagram, several conclusions about the company and areas of improvement that will help the development of the investigation, are highlighted.

Even though all the products have different paths and some of them are larger than others, there are several similar characteristics:

- Most of the material movements are made manually to help with pallet jacks and pallet trucks.
- The distances of the material transportation are long
- The paths are narrow
- The layout has a lot of obstacles (machinery, trays, pallets)
- The operators work in the middle of the corridors where the material flow cross
- Half of the movements made by the operators because of material transportation are for returning to the picking point without adding value

As can be observed, the introduction of a mobile robot as a material handling solution can reduce a lot of non-value-added activities and as an outcome, better performance, and an increase at the technological level of the company.

In particular, this investigation will focus on the sugar area due to has the largest trajectories between working stations, and, also, because the process of the family products from sugar area are only allocated at the sugar area. This last statement means that the products at the sugar area are not mixed with other products from others.

Following the methodology explain, the next steps are aligned for calculating the number of robots needed.

5.5 Theoretical calculations

5.5.1 Data analysis

First, all the information provided by the company has to be processed.

The assumptions made in this sections are:

1. The intermediate products will be gather in pallets of 320 kilograms.
2. The raw material pallets (sugar) will weight one ton each.
3. For one kilogram of sugar, it is made one kilogram of sugar product.

4. The finished product (not wrapped) will be gathered in pallets of a specific weight based on a conversion chart the company provided.
5. The packaging material will be gathered in pallets of 0,7 tons.
Each product is classified by the type of package needed. There are several cases:
 - If the client selling packaging unit (fpk) is different from the wholesaler selling packaging unit (dpc), it is needed another extra package to gather the different fpk in a dpc. The packaged needed will be a bigger and heavier box than the individual fpk package. So, it's going to be used that this package will weight 350g;
 - Sugar 1 or sugar 2 package are little cartoon board like a Tabaco pack which weight 3.5g each.
 - Sugar 3 package is a bag zip or a simple bag. For the first package alternative: there is needed two elements: plastic and zip. So there is always going to be needed 2 types of pallets. Each bag will weight 5 g and the zip 5g too; For the second alternative, the bags are a little big heavier. The bags will weight 10g.
 - Sugar 4 package. Each product needs a different size of the package. It is going to use an average bag which weights 250g; 6. Box (pick and mix): each box will weight 250g
6. The return flow will take into account that at least once a week, the trays are going to be washed.

The data provided was the number of tons packaged per each machine day by day. These numbers were converted in the number of pallets depending on the type of product. Knowing the number of tons packaged, the number of intermediate products and raw material was calculated. Then, with the number of tons of intermediate products and raw material, the number of pallets for each was calculated supported by the assumptions already explain. Furthermore, the same process was used for the packaging material.

In the end, the result of the analysis was the number of tons and the number of pallets for each row at the material flow mapping.

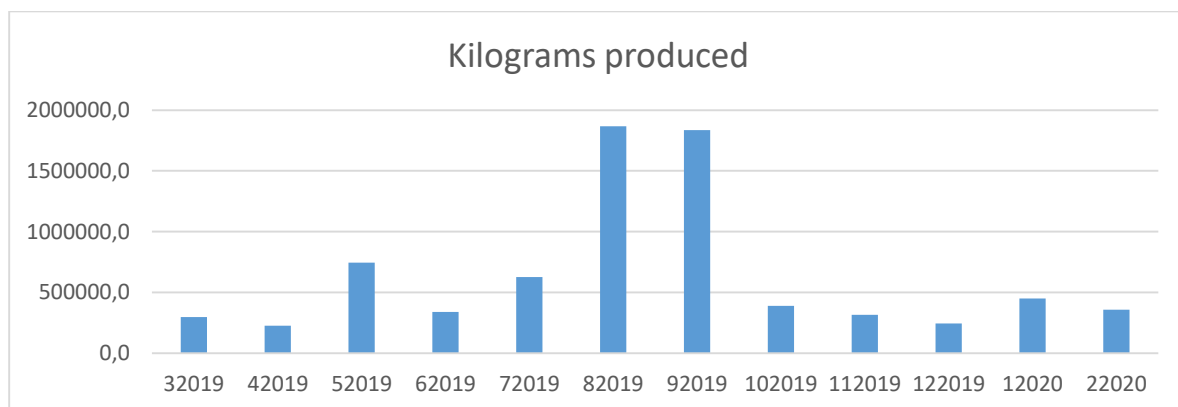

Image 18 Kilograms produced monthly

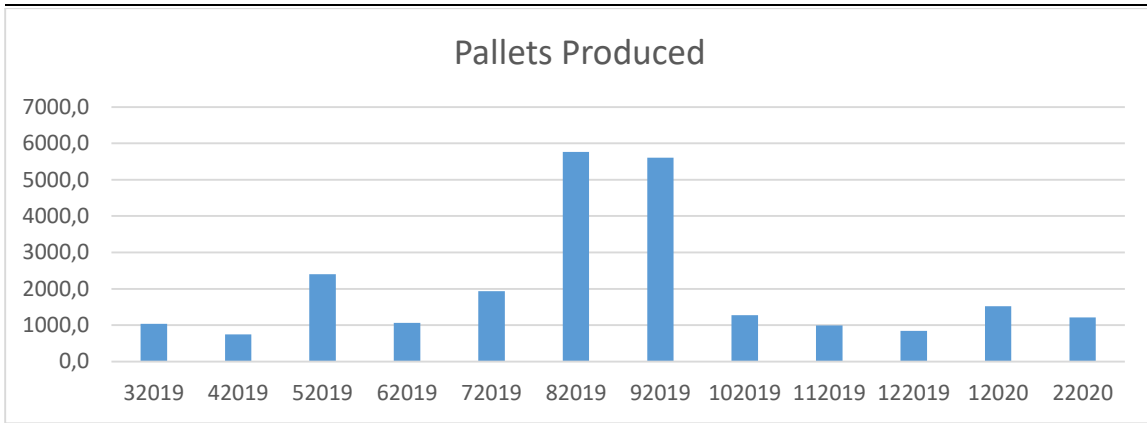

Image 19 Pallets produced monthly

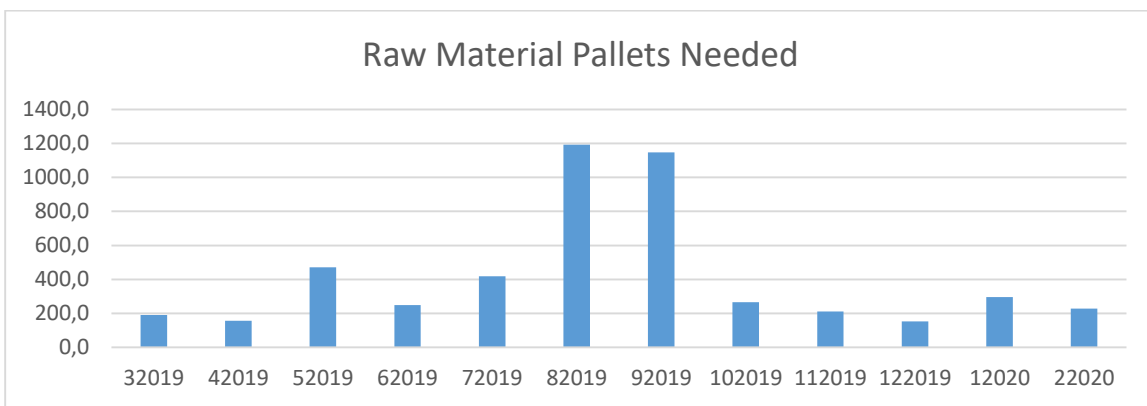

Image 20 Raw material Pallets Needed monthly

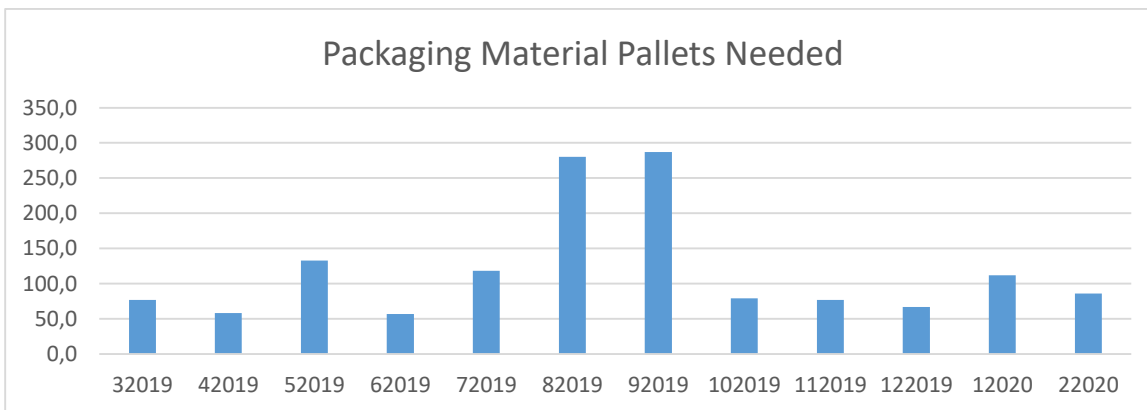

Image 21 Packaging Material Pallets Needed monthly

The information processed shows a rough pick during August and September months. According with the company, the production should not suffer any type of extreme variation and going through the data with them, we agreed to take out from the investigation these two months.

5. Case Study

5.5.2 Scenario design

The purpose of creating several scenarios is the creation of several alternatives that can adapt better to the facility and the company's requirements. The study of these alternatives will give a richer evaluation of the investigation.

The difference between scenarios will be the number of travels made by the robots.

Scenario 1

This scenario will only assume the travels between the packaging line and the wrapping area.

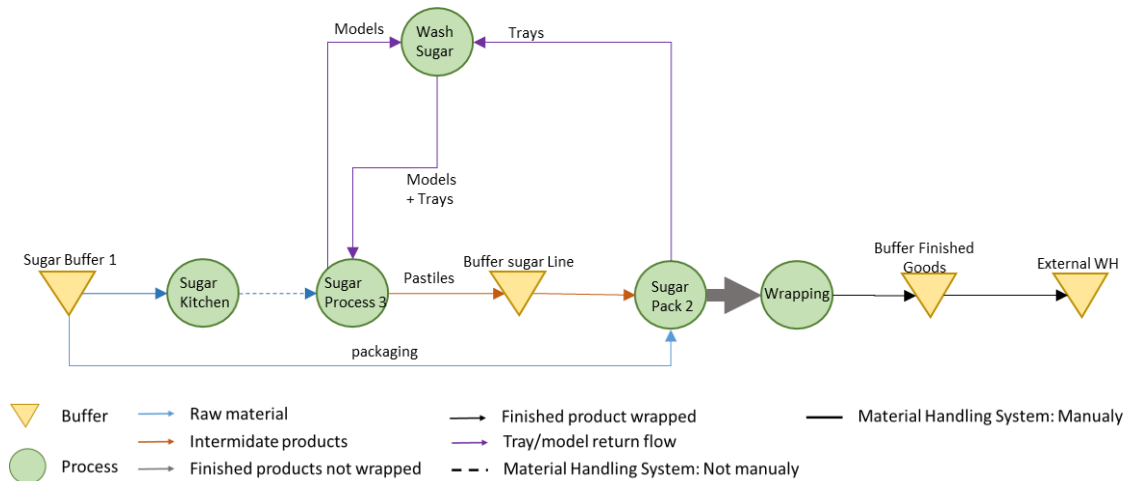

Image 22 Material flow Scenario 1

Scenario 2

In this case, the raw material and the packaging material pallets are included.

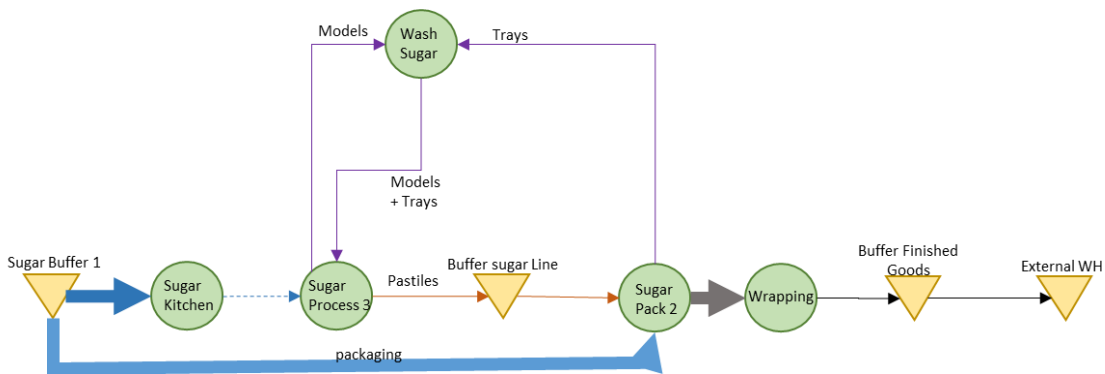

Image 23 Material Flow Scenario 2

Scenario 3

This scenario will add the intermediate product pallets travels to the Scenario 2.

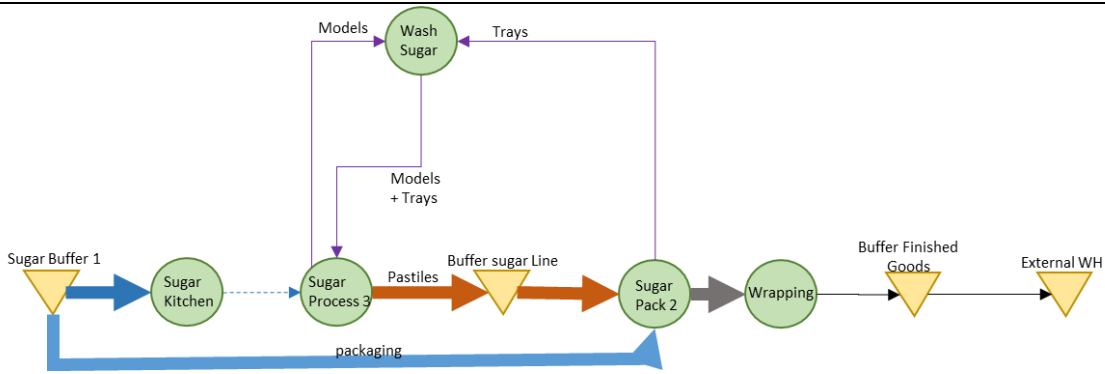

Image 24 Material Flow Scenario 3

Scenario 4

Scenario 4 will gather the following travels: raw material pallets, packaging material pallets, intermediate product pallets, ‘packaging line to wrapping’ pallets, and the return flow of the pallets that are washed.

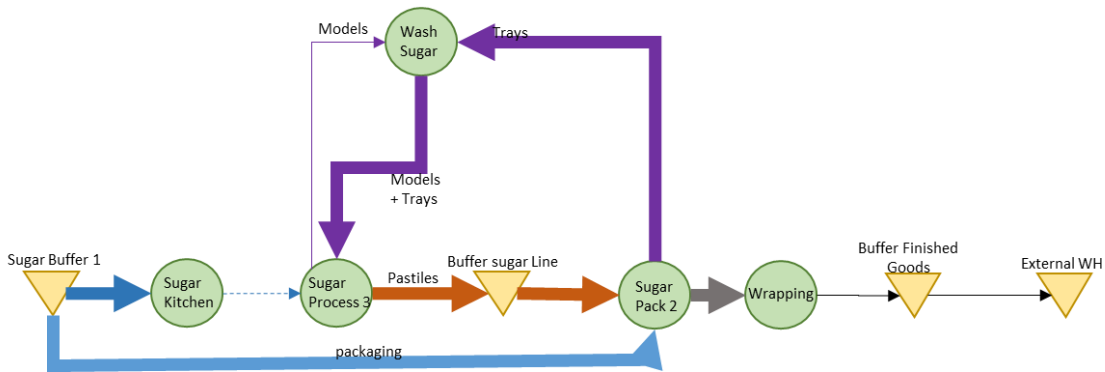

Image 25 Material Flow Scenario 4

Scenario 5

In this scenario, the travels that are going to be done are: raw material pallets, packaging material pallets, ‘packaging line to wrapping’ pallets, and the return flow of the pallets that are washed.

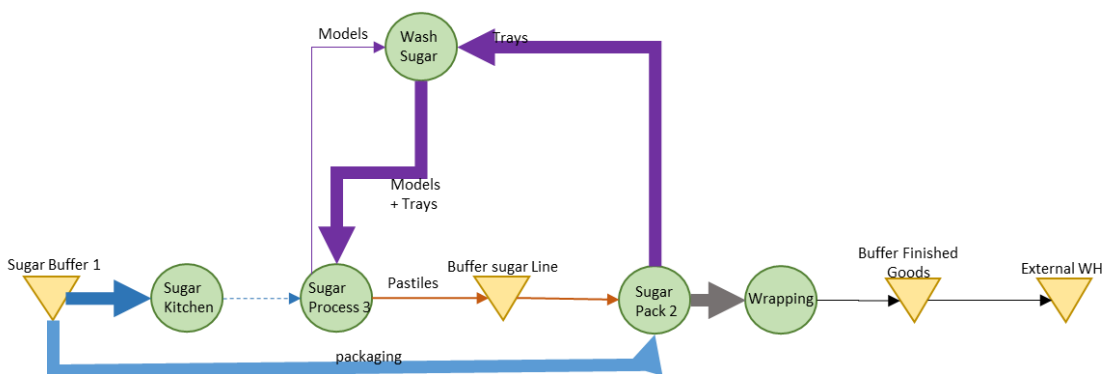

Image 26 Material Flow Scenario 5

Moreover, there will be two types of mobile robots that are going to be investigated. The first one will be a forklift AGV and the second one will be an AMR which needs a specific structure where the pallets are lifted and the robot can pick the pallets.

The AGVs can go to every workstation and move the pallets between them. However, the AMR can do it but installing a pallet structure in every workstation will not be feasible in economic terms. Maybe this idea can be faced in future work. Aligned this constrain, the AMR alternative will have an established picking point where the pallets are left by the operators and are picked by the AMR. This picking point was selected based on the number of meters traveled by the robot. Besides, if there is a picking point at the Sugar Buffer 1, the scenarios 3 and 4, where the travels of the intermediate product are included, the feasibility of using the robot will decrease. This is because the intermediate product workstations are close and going to the picking point and return to the next workstation add that many extra meters, that require more than 2 robots on average.

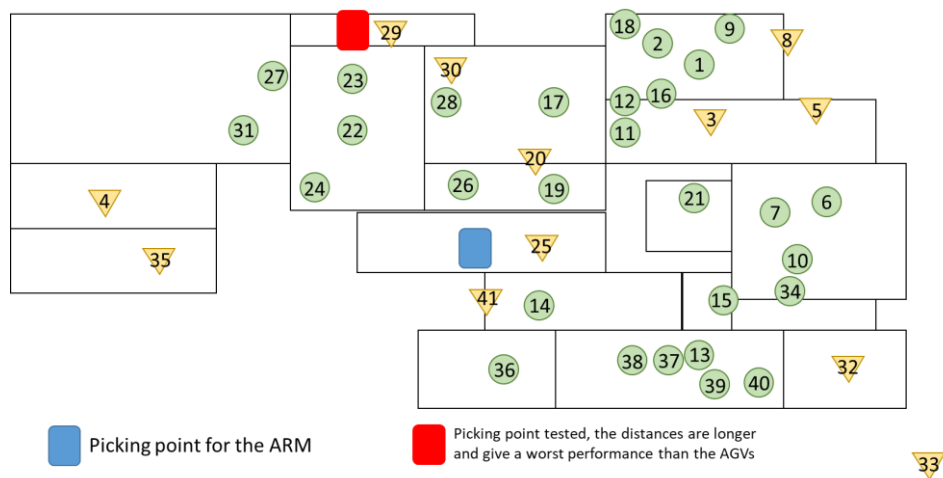

Image 27 Location Picking Point AMR scenarios

To sum up, the scenarios investigated according to the AMR limitations will be scenario 1, 2 and 5.

5.5.3 From-To Chart

Once the material flow is established, the data is analyzed, and the scenarios are created, the relation between workstation needs to be quantified. For this section, the From-To chart method will be used.

For calculating the number of robots day by day, a From-To Chart daily is needed. Besides, for future calculations, the From-To Chart monthly and year is also needed.

Furthermore, the assumptions made in this section are:

1. The raw and packaging material pallets are divided uniform every day of the year.
2. The rest of the pallets are divided uniform each day due to the data provided is daily.

As the information is confidential, and there are more than two hundred charts, the investigation is going to show only the yearly one to have a reference of the movements between the stations at the scenario 4 which includes all the possible movements.

Evaluation of automating the material handling solution in a confectionery Factory

Pallets/ year	SugarBuffer3	SugarBuffer2	SugraProcess1	SugarPack2	SugarProcess2	SugarKitchen	SugarPack3	SugarPack1	SugarProcess3	ChocoWH	Wrapping	WashSugar	Total general
SugarBuffer3					1094,17								1094,17
SugarBuffer2			1094,17	802,52			390,51	131,71					2418,90
SugraProcess1	1094,17												1094,17
SugarPack2										20,61	664,67	802,52	1487,80
SugarProcess2		1094,17											1094,17
SugarKitchen										96,13			96,13
SugarPack3										3,76	291,67	390,51	685,93
SugarPack1										2,82	262,83	131,71	397,36
SugarProcess3		1288,50											1288,50
SugarBuffer1						769,08							769,08
ChocoWH				164,92			30,08	22,58					217,58
WashSugar												2418,90	2418,90
Total general	1094,17	2382,67	1094,17	967,43	1094,17	769,08	420,59	154,29	2418,90	123,33	1219,17	1324,73	13062,68

Table 8 From-To Chart Example Scenario 4

5.5.4 Number of Robots

The calculations are going to follow the next equation:

$$N_{AGV} = \frac{T_{Total}}{T_{AGV} * A}$$

T_{total} is the sum of the time that the robot spends carrying the loads from one station to another plus the time it spends returning to the stations empty to continue its labor.

T_{AGV} is the time that the robot is operable to work and A comes from Availability and means the percentage of time where the robot is available to work due to stops of maintenance, stops for charging, and so on.

T_{total} will be defined as:

$$T_{Total} = T_{loaded} + T_{empty\ trips}$$

The T_{loaded} will be calculated as the time needed for the robot to pick up a load (in this case a pallet), carry it to the next workstation and unload the pallet at the workstation.

$$T_{loaded} = \sum_i \sum_j N_{ij} * (T_{load\ pallet} + T_{ij} + T_{unloaded\ pallet})$$

N_{ij} represent the number of trips from station I to station j.

T_{ij} represent the time that the robot takes from station I to station j. To calculate this time, it is needed to know the distance between the stations and the speed of the robots.

Assumptions made at this point:

1. Time for loading and unloading a pallet will be 30 seconds each
2. Robot speed will be 0,7 m/s
3. The availability of the robot is 0,88 due to, for eight hours working, it needs one hour to be charged
4. The distance between stations will be measured at the layout provided by the company.

5. Case Study

5. In a trip, a robot can only carry a pallet. This means that N_{ij} will be equal to the number of pallets per hour each day.
6. The company works in two shifts of eight hours.

The time of empty trips is a little more complex. Its equation is:

$$T_{empty\ trips} = \sum_i \sum_j X_{ij} * (T_{ij})$$

X_{ij} represent the number of empty trips between station i and station j .

This term is calculated by solving several equations. For a better understanding, an example is going to be shown. The example will be from Scenario 2, from January 3rd.

The information needed is: the number of pallets per hour which represent the number of trips made per hour.

Pallets/hour	SugarBuffer3	SugarBuffer2	SugraProcess1	SugarPack2	SugarProcess2	SugarKitchen	SugarPack3	SugarPack1	SugarProcess3	ChocoWH	Wrapping	WashSugar
SugarBuffer3	0,0	0,0	0,0	0,0	0,0	0,0	0,0	0,0	0,0	0,0	0,0	0,0
SugarBuffer2	0,0	0,0	0,0	0,0	0,0	0,0	0,0	0,0	0,0	0,0	0,0	0,0
SugraProcess1	0,0	0,0	0,0	0,0	0,0	0,0	0,0	0,0	0,0	0,0	0,0	0,0
SugarPack2	0,0	0,0	0,0	0,0	0,0	0,0	0,0	0,0	0,0	0,0	0,2	0,0
SugarProcess2	0,0	0,0	0,0	0,0	0,0	0,0	0,0	0,0	0,0	0,0	0,0	0,0
SugarKitchen	0,0	0,0	0,0	0,0	0,0	0,0	0,0	0,0	0,0	0,0	0,0	0,0
SugarPack3	0,0	0,0	0,0	0,0	0,0	0,0	0,0	0,0	0,0	0,0	0,0	0,0
SugarPack1	0,0	0,0	0,0	0,0	0,0	0,0	0,0	0,0	0,0	0,0	1,5	0,0
SugarProcess3	0,0	0,0	0,0	0,0	0,0	0,0	0,0	0,0	0,0	0,0	0,0	0,0
SugarBuffer1	0,0	0,0	0,0	0,0	0,0	0,9	0,0	0,0	0,0	0,0	0,0	0,0
ChocoWH	0,0	0,0	0,0	0,2	0,0	0,0	0,1	0,1	0,0	0,0	0,0	0,0
WashSugar	0,0	0,0	0,0	0,0	0,0	0,0	0,0	0,0	0,0	0,0	0,0	0,0

Table 9 From to Chart per hour

Then the number of trips to a workstation and the number of trips from a workstation needs to be calculated.

Resource	SugarBuffer3	SugarBuffer2	SugraProcess1	SugarPack2	SugarProcess2	SugarKitchen	SugarPack3	SugarPack1	SugarProcess3	ChocoWH	Wrapping	SugarBuffer1
From	0,00	0,00	0,00	0,19	0,00	0,0	0,00	1,50	0,00	0,33	0	0,88
To	0,00	0,00	0,00	0,19	0,00	0,88	0,06	0,09	0,00	0,00	1,69	0
To - From	0,00	0,00	0,00	0,00	0,00	0,88	0,06	-1,41	0,00	-0,33	1,69	-0,88
Leaving empty trips	SugarBuffer3	SugarBuffer2	SugraProcess1	SugarPack2	SugarProcess2	SugarKitchen	SugarPack3	SugarPack1	SugarProcess3	ChocoWH	Wrapping	SugarBuffer1
Resource	0,00	0,00	0,00	0,00	0,00	0,88	0,06	0,00	0,00	0,00	1,69	0,00
Arriving empty trips	SugarBuffer3	SugarBuffer2	SugraProcess1	SugarPack2	SugarProcess2	SugarKitchen	SugarPack3	SugarPack1	SugarProcess3	ChocoWH	Wrapping	SugarBuffer1
Resource	0,00	0,00	0,00	0,00	0,00	0,00	0,00	1,41	0,00	0,33	0,00	0,88

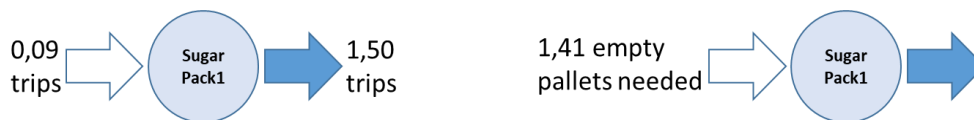

Image 28 Matrix of Return flow

Understanding that some workstations are going to be the source of empty pallets and the other workstations are going to be the client of those empty trips, the matrix of equation is built:

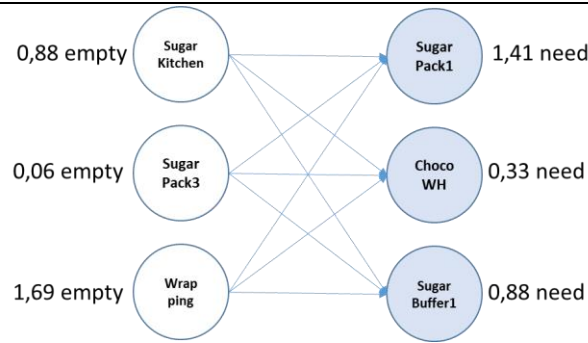

Image 29 Equations empty trips

Equations: Leaving empty trips from i

$$X_{sk-sp1} + X_{sk-cwh} + X_{sk-sb1} = 0,88$$

$$X_{sp3-sp1} + X_{sp3-cwh} + X_{sp3-sb1} = 0,06$$

$$X_{w-sp1} + X_{w-cwh} + X_{w-sb1} = 1,69$$

Equations: Arriving empty trips to j

$$X_{sk-sp1} + X_{sp3-sp1} + X_{w-sp1} = 1,41$$

$$X_{sk-cwh} + X_{sp3-cwh} + X_{w-cwh} = 0,33$$

$$X_{sk-sb1} + X_{sp3-sb1} + X_{w-sb1} = 0,88$$

A solution could be:

$$X_{sk-sb1} = 0,88$$

$$X_{sp3-cwh} = 0,06$$

$$X_{w-cwh} = 0,28$$

$$X_{w-sp1} = 1,41$$

This process will be done for each scenario, each day of the whole year. Automating the calculation was not possible with Excel solver due to the high amount of variables. Hence, the investigation assumed that:

1. The time empty trips will be calculated as a percentage of the time load. For accuracy, the percentage will be the result from the time empty trips divided by the time load of each month and scenario. This reduces the number of calculations.

Following all this steps and help by Excel programs, the result of the number of robots day by day is calculated. Then, this information has been analyzed to understand the requirements of each scenario and also, to calculate the number of days the robot needs help from operators to finish the task.

Here are the results:

This chart represent the percentage of the days cover by one, two, three, four or five robots.

Nº AGVs	Scce 1	Scce 2	Scce 3	Scce 4	Scce 5
1	100%	100%	81%	67%	93%
2	100%	100%	96%	93%	99%
3	100%	100%	98%	97%	100%
4	100%	100%	100%	100%	100%
5	100%	100%	100%	100%	100%

Table 10 Days covered by the Robot

This means, that the scenario 1 is covered by one robot, meanwhile the scenario 4 needs four robots to covered every day of the year. It is interested to see that with one robot is covered a high percentage of the work.

The days which required workforce are the following:

Nº AGVs	Scce 1	Scce 2	Scce 3	Scce 4	Scce 5
1	0,00	0,00	36,00	63,00	14,00
2	0,00	0,00	8,00	13,00	1,00

Table 11 Days when workforce is required

The results for the AMR scenario are next:

Nº AMRs	Scce 1	Scce 2	Scce 5
1	99%	97%	77%
2	100%	100%	90%

Table 12 Days covered by the Robot

Nº AMRs	Scce 1	Scce 2	Scce 5
1	0,00	0,00	14,00
2	0,00	0,00	1,00

Table 13 Days when workforce is required

With these first results, it can be observed that some alternatives can be scenario 1, 2 and 5 with one mobile robot (AGV or AMR) due to the high percentage covered.

5.6 Simulation

As it was explained in the 'Methodology' section, there are several steps to follow:

1. Configuration of the layout.
2. Coding the program
3. Simulate the different scenarios to gather information

5.6.1 Configuration Layout

The limitation of the program used, leads to a basic layout where all the workstations are allocated following the coordinates from the map provided.

The layout created will look like image X shown.

The red squares are the different workstations and the path is color in purple.

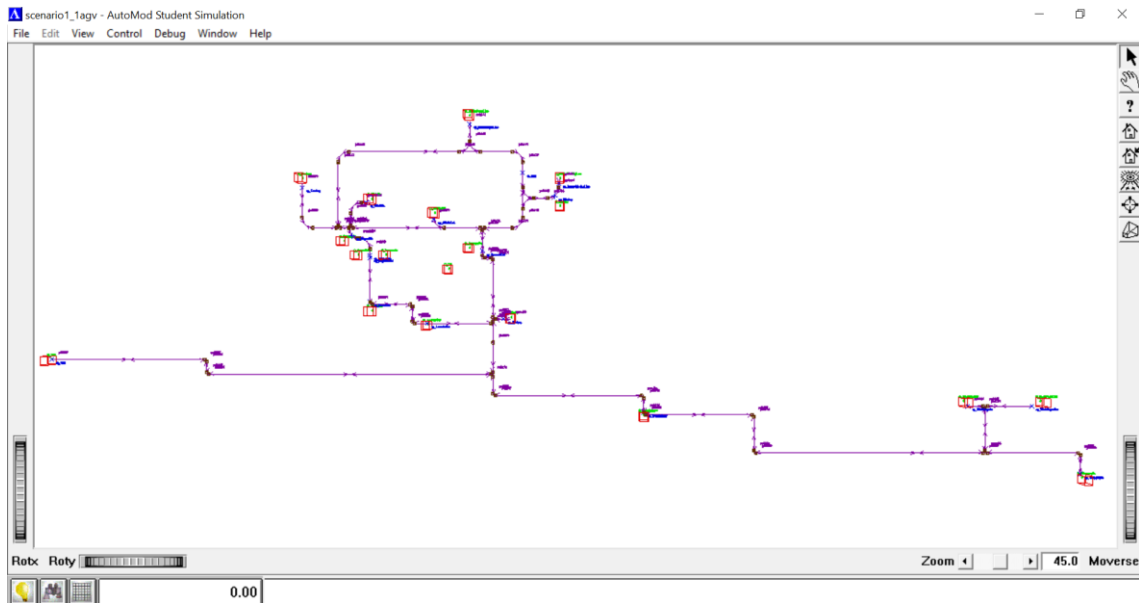

Image 30 Layout displayed in AutoMod

5.6.2 Programming the triggers

AutoMod facilitates the configuration of the program. The code was based in a particular language code where you need to link process by process to create a material flow.

Moreover, the simulation objective was to represent the day by day of the facility at the sugar area with the higher precision as the program let. According to this, the simulation is representing day by day the creation of the pallets following the From-To Chart daily calculated before. This information is given to the program by a text file that AutoMod is going to read. Every time, the program reads a new creation of a pallet, it also reads the hour of creation and the type. The code is programmed so based on the type of the pallet one material flow is triggered or another.

Besides, for a better simulation, the days that the work assigned to the robots is over their capacity, are not going to be represented as they are. These days are going to be substituted by a day with the same characteristics that have the full capacity of their robots. This assumption permits not to accumulate the error of overcapacity that the robots cannot cover.

The code will be shown as an annex.

5.6.3 Simulation and Information

All the scenarios were simulated and all the alternatives. To sum up, there were two types of mobile robots (AGV, AMR). The AGVs has five types of scenarios and the simulation takes into account two other alternatives: representing the work of one or two robots. In the case of AMR, there are three types of scenario, which are going to be simulated with one and two robots, too.

The information gathered by running the simulation is:

1. Maximum capacity needed at the different workstations
2. Average WIP at the different workstations
3. Percentage of robots' usage

All this data has been processed with the purpose of obtaining information for the next step, the Comparison Cost Chart. It will be shown at the next section and as an annex.

5.7 Comparison Cost Chart

The objective of this chart is proving an objective method to evaluate the different scenarios simulated.

For this evaluation, it has been thought several costs that depending on the alternative change. For example, the cost of maintenance the facility will not change between one scenario or another, this cost will not be included. Meanwhile, the cost of workforce needed change from one scenario to another, this cost is relevant in this chart.

The cost selection is:

5.7.1 Cost WIP year

This cost wants to represent the amount of money the company will not be able to spend or invest due to the pallets are waiting to be collected by the mobile robots.

$$C_{WIP} = \text{Average WIP year} * \text{Average cost of one pallet} * \text{percentage holding cost}$$

The assumption made here is that the holding cost is 15% of the total average pallet cost.

The average cost of one pallet at the sugar area will be calculated like:

$$C_{Pallet} = \frac{\text{Turnover}}{3 * \text{Total pallets produced}}$$

The turnover is divided by three to split the income equal between the three areas of products.

5.7.2 Cost space WIP year

The pallets waiting at the different workstation queues needs a space that is limited and that occupied a certain squares meters which can be used with other purpose that can increase the productivity or the income.

$$C_{spaceWIP} = \text{Dimension europallet} * \frac{\text{Turnover}}{\text{squares meters layout}} * \sum \text{maximum capacity of each WS queue}$$

5.7.3 Cost Operator

This cost is related with the days the work assigned to the robots is above their capacity. In this case, workforce is needed. With the information provided by the theoretical calculations, the extra hours needed can be quantified.

$$C_{spaceWIP} = \text{Operator salary per hour} \\ * \left(\sum \text{Extra hours} \right) \\ + \sum \text{Hours needed at AMR scenarios to move pallets to picking point}$$

The average salary for an operator in Norway is around: 150 kr/hour (Salary Explorer, 2020)

5.7.4 Cost Robot

$$C_{WIP} = \text{Number of robots needed} * \text{Cost of one robot}$$

The assumptions made are the following (agvnetwork, 2020):

1. Cost of a forklift AGV: 80.000 NOKs
2. Cost of an AMR: 70.000 NOKs

5.7.5 Cost Implementation

This cost can be described as the price of the software, the path design, the installation of the sensors if they are needed around the facility.

$$C_{implementatio} = \text{Cost of implementation of one robot} * \text{if}(there\ is\ 2\ robots; 1.3; 1)$$

Furthermore, implementing a second robot should not be the double of the price due to the factors taken into account are shared by the number of robots available. This means that each robot does not need one software each, because it is the same. The same happens to the sensor placed around the facilities. This is the reason, if the scenario requires a second robot, the cost of implementation will only increase a 30% of the cost.

The cost of implementing one robot rises up to, in the case of AGVs, 350.000 NOKs, and, in the case of AMRs, 200.000 NOKs (agvnetwork,2020).

5.7.6 Cost Electricity

It is the only cost related with the average use of the robot in each alternative.

$$C_{electricity} = \text{Consumption (kWh)} * \text{number of robots} * \text{operable hours per year} \\ * \text{rate of use} * \text{cost of 1 kWh}$$

The assumptions made in this sections:

1. The robots consume 2kWh (MiR, 2020)
2. Operable hours: eight hours per shift, two shifts, 191 days
3. The cost of one kWh in Norway the day the calculation was done, was: 2,7 NOKs (statista, 2018)

Moreover, aside of the costs, the evaluation will be more accuracy if a sensitive analysis is done. For this, there is going to present three different scenarios: favorable, unfavorable and neutral. The difference between them are:

5. Case Study

Factor	Unfavorable	Neutral	Favorable
Turnover	-20%	0%	+20%
Price robots	+20%	0%	-20%
Price Electricity	+20%	0%	-20%
Implementation cost of 2nd robot	2	1,33	1

Table 14 Difference between Scenarios

These assumptions want to represent the different performance each solution can have in a short future, either if in a short future the company grows or not.

5.8 Results

In this sections, all the results from the Comparison Cost chart are going to be shown.

5.8.1 Neutral Scenario

Scenario	Robot	Total cost	% Robot	rate: use/cost
1	1AGV	1410459,27	10,56	7%
2	1AGV	1671029,70	17,34	10%
3	1AGV	4539799,76	55,91	12%
4	1AGV	6613403,12	77,03	12%
5	1AGV	2633837,78	44,21	17%
1	2AGV	2315423,27	5,10	2%
2	2AGV	2662699,69	8,59	3%
3	2AGV	3412902,38	33,41	10%
4	2AGV	10025378,42	48,10	5%
5	2AGV	3487724,30	22,48	6%
1	1AMR	489182,95	8,37	17%
2	1AMR	750847,75	12,63	17%
5	1AMR	1116303,25	32,34	29%
1	2AMR	619157,90	4,10	7%
2	2AMR	880778,87	6,25	7%
5	2AMR	1238994,25	15,67	13%

Table 15 Costs incurred in Neutral Scenario

5.8.2 Unfavorable Scenario

Scenario	Robot	Total cost	% Robot	rate: use/cost
1	1AGV	1518386,83	10,56	7%
2	1AGV	1726884,82	17,34	10%
3	1AGV	4031536,75	55,91	14%
4	1AGV	5697239,32	77,03	14%
5	1AGV	2498760,61	44,21	18%
1	2AGV	2828350,82	5,10	2%
2	2AGV	3106197,32	8,59	3%
3	2AGV	3708861,43	33,41	9%
4	2AGV	9002168,95	48,10	5%
5	2AGV	3766325,87	22,48	6%
1	1AMR	459789,25	8,37	18%
2	1AMR	669381,61	12,63	19%
5	1AMR	965407,18	32,34	34%
1	2AMR	743764,20	4,10	6%
2	2AMR	953312,72	6,25	7%
5	2AMR	1242098,18	15,67	13%

Table 16 Costs incurred in unfavorable Scenario

5.8.3

Favorable Scenario

Scenario	Robot	Total cost	% Robot	rate: use/cost
1	1AGV	1302531,71	10,56	8%
2	1AGV	1615174,58	17,34	11%
3	1AGV	5048062,76	55,91	11%
4	1AGV	7529566,92	77,03	10%
5	1AGV	2768914,95	44,21	16%
1	2AGV	1942495,71	5,10	3%
2	2AGV	2359202,05	8,59	4%
3	2AGV	3256943,32	33,41	10%
4	2AGV	11188587,90	48,10	4%
5	2AGV	3349122,73	22,48	7%
1	1AMR	518576,65	8,37	16%
2	1AMR	832313,89	12,63	15%
5	1AMR	1267199,31	32,34	26%
1	2AMR	574551,60	4,10	7%
2	2AMR	888245,01	6,25	7%
5	2AMR	1315890,31	15,67	12%

Table 17 Costs incurred in Favorable Scenario

For helping the evaluation, in the results, it has added a new column about the rate between the percentage of robot usage and the total cost.

The range of colors are selected on purpose, so at first sight, the reader can be able to understand which is the alternative most expensive, which alternative has a better usage of a robot and which one has the best relation between cost and usage.

Moreover, gathering all the information, it could be observed that the alternatives of Scenario 4 driven by one or two AGVs are not feasible due to the requirement of space needed at the wash sugar station. These alternatives have 64 and 134 pallets with 40 trays each cleaned waiting to be lifted to the buffer area. Even though these pallets can be stacked, the amount of space needed is not available at the facility.

After all the study is done, all the scenarios have been simulated and the results have been achieved, it is time to evaluate the results and find a suitable solution that meets the requirements of the company and gives a good performance.

5.9 Decision and Discussion

In this section, the evaluation of the Comparison Cost chart is going to be analyzed taking into consideration the knowledge gathered with the literature reviews and the case of study. This will be the answer to the second research question.

RQ2: Which is the best solution for automating the material handling system in Company X?

According to the literature reviews, all the investigations developed the last few years point to the AMR solutions as the new alternative for increase the performance of the company due to the level of flexibility and adaptability it can hold.

Furthermore, the theoretical calculations give a first approach of which alternatives can be more suitable. However, it only takes into consideration the percentage of work covered by robots. This first approach is scenarios 1, 2, and 5 with one mobile robot. With this information choosing a type of mobile robot is not possible.

Moreover, the simulation provided relevant information to build the Comparison Cost Chart. The three scenarios at the chart provide very similar use-cost rates. Hence, even though the close future predicts a growth or a decrease in the company's performance, the suitable alternatives for automating the material handling system will remain the same.

Looking at the results of the costs, the alternatives with the highest use-cost rate are the scenarios with one AMR and thee scenario 5 performed by one AGV. However, if it is observed the percentage of robot usage or the total cost, there are different positions. On the one hand, if only the total cost was into consideration, the alternatives with AMR are the cheapest ones. On the other hand, if the percentage of robot's usage, the AGV scenarios will be more suitable.

Before making more conclusions, it is needed to remind that Scenario 4 driven by one or two AGVs are not feasible due to the space constraint at the wash sugar station.

Continuing with the evaluation, two alternatives have a high rate and high usage of the robot: scenario 5 driven by one AGV or one AMR. The difference between both alternatives is 12%

more of usage of AGV but the double price. Besides, knowing that the AMR is more flexible and adaptable to the layouts, which also allows being used in other areas or extended its used in the same area without making a big investment again.

Taking into consideration all the points of view, this investigation leads to the most suitable solution for automating the material handling solution is to implement an AMR in Scenario 5.

6.CONCLUSION

The investigation has the objective of comprehending the requirements for implementing automated material handling systems at the Food Industry and put the knowledge in practice in a confectionery factory.

The conclusion obtained by the literature review is related to the opportunity of implementing an automating material handling solution in the Food industry. It is explained that the Food industry has room for improvement in this area due to there is not a lot of investigation around this topic. Besides, the other sectors have to implement this technology for a long time ago with great results. In particular, the researches point out that the new direction at the material handling system is AMRs. Also, the AMR solution provides a high level of flexibility which is the suitable characteristic for meeting the Food industry and a fixed layout's requirements.

Furthermore, the investigation has been completed by a case of study of a confectionery factory which has provided all the necessary data. After theoretical calculations about the number of robots in different possible scenarios and the simulation of each scenario, the comparison cost chart was completed and analyzed. This analysis is focused on the evaluation of the total costs that will be incurred in each scenario and the percentage of robot usage. The result of this evaluation was that the alternative of Scenario 5 driven by an AMR will be the most suitable. In this analysis, the information gathered and the conclusions got from the literature review and the theoretical calculation have been taken into account.

Annex

Code AutoMod

```
begin model initialization function
create 1 load of type L_Pallet to P_Read

return true

end

begin P_Read arriving
while 1=1 do begin

read A_Time, A_Parttype, A_Traveltime
from "arc/R_Escenario_1.txt" with
delimiter "\t"

if A_Parttype = "L_RovemaOutWrapping"
then clone 1 load to P_RovemaOut nlt
L_RovemaOutWrapping

else if A_Parttype = "L_GIMAOutWrapping"
then clone 1 load to P_GIMAOut nlt
L_GIMAOutWrapping

else if A_Parttype =
"L_LosvektOutWrapping" then clone 1 load
to P_LosvektOut nlt
L_LosvektOutWrapping

else if A_Parttype = "L_Stoperi1BSL" then
clone 1 load to P_Stoperi1Out nlt
L_Stoperi1BSL

else if A_Parttype = "L_BSLGIMAIn" then
clone 1 load to P_BSLOutGIMA nlt
L_BSLGIMAIn

else if A_Parttype = "L_BSLCoating" then
clone 1 load to P_BSLOutCoating nlt
L_BSLCoating

else if A_Parttype = "L_BSLRovemaIn" then
clone 1 load to P_BSLOutRovema nlt
L_BSLRovemaIn

else if A_Parttype = "L_BSLLosvektIn" then
clone 1 load to P_BSLOutLosvekt nlt
L_BSLLosvektIn

else if A_Parttype = "L_WHGIMAOut" then
clone 1 load to P_WHOutGIMA nlt
L_WHGIMAOut

else if A_Parttype = "L_WHRovemaIn" then
clone 1 load to P_WHOutRovema nlt
L_WHRovemaIn

else if A_Parttype = "L_WHLosvektIn" then
clone 1 load to P_WHOutLosvekt nlt
L_WHLosvektIn

else if A_Parttype = "L_TransittlagerKitch"
then clone 1 load to P_Transittlager nlt
L_TransittlagerKitch

else if A_Parttype = "L_CoatingBGL" then
clone 1 load to P_CoatingOut nlt
L_CoatingBGL

else if A_Parttype = "L_BGLGlacing" then
clone 1 load to P_BGLOut nlt L_BGLGlacing

else if A_Parttype = "L_GlacingBSL" then
clone 1 load to P_GlacingOut nlt
L_GlacingBSL

else if A_Parttype = "L_GIMAInWS" then
clone 1 load to P_GIMAIn1 nlt
L_GIMAInWS

else if A_Parttype = "L_RovemaInWS" then
clone 1 load to P_RovemaIn1 nlt
L_RovemaInWS

else if A_Parttype = "L_LosvektInWS" then
clone 1 load to P_LosvektIn1 nlt
L_LosvektInWS
```



```
send to P_LosvektIn
end
/*7*/
begin P_BSLOutRovema arriving procedure
move into Q_BufferSugarLine
wait for 30 sec
move into AVG1.cp_BufferSugarLine
send to P_RovemaIn
end
```

```
/*8*/
begin P_WHOutGIMA arriving procedure
move into Q_WH
wait for 30 sec
move into AVG1.cp_WH
send to P_GIMAOut1
end
```

```
/*9*/
begin P_BGLOut arriving procedure
move into Q_BufferGlacingLine
wait for 30 sec
move into AVG1.cp_BufferGlacingLine
send to P_GlacingIn
end
```

```
/*10*/
begin P_Transittlager arriving procedure
move into Q_Transittlager
wait for 30 sec
move into AVG1.cp_Transittlager
```

```
send to P_Kitchen
end
/*11*/
begin P_WHOutLosvekt arriving procedure
move into Q_WH
wait for 30 sec
move into AVG1.cp_WH
send to P_LosvektOut1
end
```

```
/*12*/
begin P_WHOutRovema arriving procedure
move into Q_WH
wait for 30 sec
move into AVG1.cp_WH
send to P_RovemaOut1
end
```

```
/*13*/
begin P_GIMAOut arriving procedure
move into Q_GIMAOut
wait for 30 sec
move into AVG1.cp_GIMAOut
send to P_WrappingIn
end
```

```
/*14*/
begin P_RovemaOut arriving procedure
move into Q_RovemaOut
wait for 30 sec
move into AVG1.cp_RovemaOut
send to P_WrappingIn
end
```

```

/*15*/
begin P_LosvektOut arriving procedure
move into Q_LosvektOut
wait for 30 sec
move into AVG1.cp_LosvektOut
send to P_WrappingIn
end

/*16*/
begin P_GIMAln1 arriving procedure
move into Q_GIMAln
wait for 30 sec
move into AVG1.cp_GIMAln
send to P_WashSugarIn
end

/*17*/
begin P_LosvektIn1 arriving procedure
move into Q_LosvektIn
wait for 30 sec
move into AVG1.cp_LosvektIn
send to P_WashSugarIn
end

/*18*/
begin P_RovemalIn1 arriving procedure
move into Q_RovemalIn
wait for 30 sec
move into AVG1.cp_RovemalIn
send to P_WashSugarIn
end

/*19*/
begin P_BGLIn arriving procedure
travel to AVG1.cp_BufferGlacingLine
wait for 30 sec
move into Q_BufferGlacingLine
send to die
end
/*20*/
begin P_BSLIn arriving procedure
travel to AVG1.cp_BufferSugarLine
wait for 30 sec
move into Q_BufferSugarLine
send to die
end
/*21*/
begin P_CoatingIn arriving procedure
travel to AVG1.cp_Coating
wait for 30 sec
move into Q_Coating
send to die
end
/*22*/
begin P_GIMAln arriving procedure
travel to AVG1.cp_GIMAln
wait for 30 sec
move into Q_Die
/*move into Q_GIMAln*/
send to die
end
/*23*/
begin P_LosvektIn arriving procedure
travel to AVG1.cp_LosvektIn
wait for 30 sec

```

```
move into Q_Die
/*move into Q_LosvektIn*/
send to die
end
/*24*/
begin P_RovemaIn arriving procedure
travel to AVG1.cp_RovemaIn
wait for 30 sec
move into Q_Die
/*move into Q_RovemaIn*/
send to die
end

/*25*/
begin P_GIMAOOut1 arriving procedure
travel to AVG1.cp_GIMAOOut
wait for 30 sec
move into Q_Die
/* move into Q_GIMAOOut*/
send to die
end

/*26*/
begin P_GlacingIn arriving procedure
travel to AVG1.cp_Glacing
wait for 30 sec
move into Q_Glacing
send to die
end

/*27*/
```

```
begin P_Kitchen arriving procedure
travel to AVG1.cp_Kitchen
wait for 30 sec
move into Q_Kitchen
send to die
end
/*28*/
begin P_LosvektOut1 arriving procedure
travel to AVG1.cp_LosvektOut
move into Q_Die
/*move into Q_LosvektOut*/
wait for 30 sec
send to die
end
/*29*/
begin P_RovemaOut1 arriving procedure
travel to AVG1.cp_RovemaOut
wait for 30 sec
move into Q_Die
/*move into Q_RovemaOut*/
send to die
end

/*30*/
begin P_WrappingIn arriving procedure
travel to AVG1.cp_WrappingIn
wait for 30 sec
move into Q_WrappingIn
send to die
end
```

```

/*31*/
begin P_WashSugarIn arriving procedure
travel to AVG1.cp_WashSugarIn
wait for 30 sec
move into Q_WashSugarIn
send to die
end
/*32*/
begin P_WashSugarOut arriving procedure
move into Q_WashSugarOut
wait for 30 sec
move into AVG1.cp_WashSugarOut
send to P_Stoperi1In
end
/*33*/
begin P_Stoperi1In arriving procedure
travel to AVG1.cp_Stoperi1In
wait for 30 sec
/*move into Q_Die*/
move into Q_Stoperi1In
send to die
end
/*34*/
begin P_ReturnGIMAOOutWH arriving
procedure
move into Q_GIMAOOut
wait for 30 sec
move into AVG1.cp_GIMAOOut
send to P_WHIn
end
/*35*/
begin P_ReturnRovemaOutWH arriving
procedure
move into Q_RovemaOut
wait for 30 sec
move into AVG1.cp_RovemaOut
send to P_WHIn
end
/*36*/
begin P_ReturnLosvektOutWH arriving
procedure
move into Q_LosvektOut
wait for 30 sec
move into AVG1.cp_RovemaOut
send to P_WHIn
end
/*37*/
begin P_ReturnKitchenWH arriving
procedure
move into Q_Kitchen
wait for 30 sec
move into AVG1.cp_Kitchen
send to P_WHIn
end
/*38*/
begin P_WHIn arriving procedure
travel to AVG1.cp_WH
wait for 30 sec
move into Q_WH
send to die
end

```

Scenario	Robot	MAX Capacity WashSugarIn	Average WIP WashSugarIn	MAX Capacity WashSugarOut	Average WIP WashSugarOut	MAX Capacity Rovemaln	Average WIP Rovemaln	MAX Capacity GIMAln	Average WIP GIMAln	MAX Capacity LosvektIn	Average WIP LosvektIn	MAX Capacity PickingPoint	Average WIP PickingPoint	% use AVG
1	1AGV	0	0	0	0	0	0	0	0	0	0	0	0	10,558
2	1AGV	0	0	0	0	0	0	0	0	0	0	0	0	17,34
3	1AGV	0	0	0	0	0	0	0	0	0	0	0	0	55,911
4	1AGV	1	0,005	64	3,315	1	0,022	1	0,061	2	0,119	0	0	77,026
5	1AGV	1	0,005	6	0,319	1	0,005	2	0,046	2	0,086	0	0	44,213
1	2AGV	0	0	0	0	0	0	0	0	0	0	0	0	5,097
2	2AGV	0	0	0	0	0	0	0	0	0	0	0	0	8,5875
3	2AGV	0	0	0	0	0	0	0	0	0	0	0	0	33,413
4	2AGV	1	0,007	134	5,618	1	0,009	1	0,027	3	0,091	0	0	48,0955
5	2AGV	1	0,005	6	0,12	1	0,002	2	0,028	2	0,046	0	0	22,484
1	1AMR	0	0	0	0	0	0	0	0	0	0	5	0,087	8,371
2	1AMR	0	0	0	0	0	0	0	0	0	0	8	0,175	12,629
5	1AMR	0	0	0	0	0	0	0	0	0	0	16	0,795	32,344
1	2AMR	0	0	0	0	0	0	0	0	0	0	5	0,071	4,096
2	2AMR	0	0	0	0	0	0	0	0	0	0	8	0,131	6,2525
5	2AMR	0	0	0	0	0	0	0	0	0	0	16	0,451	15,669

Neutral Scenario

Scenario	Robot	Total Average WIP	Cost WIP (Kr) /year	Feasible space pallets	Space needed	Cost m^3 (kr)	Worfce (days)	Workforce (hours)	Workforce (moving pallets to picking point)	Cost operator (Kr)	Cost robot (kr)	Cost implementation	cost electricity
1	1AGV	0,062	97,063654		5,76	260362,2089	0	0	0	0	800000	350000	1742,323392
2	1AGV	0,195	305,2808473		11,52	520724,4179	0	0	0	0	800000	350000	2861,51616
3	1AGV	1,864	2918,171791		73,92	3341315,015	57	303,777135	0	45566,57025	800000	350000	9226,656864
4	1AGV	6,385	9995,990819	not WS	119,04	5380818,985	100	483,920963	0	72588,14444	800000	350000	12711,13862
5	1AGV	0,983	1538,928579		32,64	1475385,851	15	46,086674	0	6913,001099	800000	350000	7296,206112
1	2AGV	0,039	61,05616945		5,76	260362,2089	0	0	0	0	1600000	455000	1682,254656
2	2AGV	0,12	187,8651368		13,44	607511,8209	0	0	0	0	1600000	455000	2834,2872
3	2AGV	0,98	1534,23195	not WS	29,76	1345204,746	15	74,42264966	0	11163,39745	1600000	455000	11027,89382
4	2AGV	6,815216	10669,51238		175,68	7941047,373	22	124,4102467	0	18661,53701	1600000	455000	15873,82358
5	2AGV	0,446	698,2320917		31,68	1431992,149	1	0,226125062	0	33,9187593	1600000	455000	7420,799232
1	1AMR	0,087	136,2022242		4,8	216968,5074	0	0	13,85493827	2078,240741	70000	200000	1381,415904
2	1AMR	0,175	273,9699911		10,56	477330,7164	0	0	21,62043418	3243,065126	70000	200000	2084,088096
5	1AMR	0,795	1244,606531		18,24	824480,3283	15	46,64505236	90,5437047	20578,31356	70000	200000	5337,536256
1	2AMR	0,071	111,1535393		4,8	216968,5074	0	0	13,85493827	2078,240741	140000	260000	1351,876608
2	2AMR	0,131	205,0861077		10,56	477330,7164	0	0	21,62043418	3243,065126	140000	260000	2063,62512
5	2AMR	0,451	706,0598057		18,24	824480,3283	1	1,508683656	90,5437047	13807,85825	140000	260000	5171,522112

Unfavorable Scenario

Scenario	Robot	Total Average WIP	Cost WIP (Kr) /year	Feasible space pallets	Space needed	Cost m^2 (kr)	Worforce (days)	Workforce (hours)	Workforce (moving pallets to picking point)	Cost operator (Kr)	Cost robot (kr)	Cost implementation	cost electricity
1	1AGV	0,062	97,063654		5,76	208289,7672	0	0	0	0	960000	350000	1393,858714
2	1AGV	0,195	305,2808473		11,52	416579,5343	0	0	0	0	960000	350000	2289,212928
3	1AGV	1,864	2918,171791		73,92	2673052,012	57	303,777135	0	45566,57025	960000	350000	7381,325491
4	1AGV	6,385	9995,990819	not WS	119,04	4304655,188	100	483,920963	0	72588,14444	960000	350000	10168,9109
5	1AGV	0,983	1538,928579		32,64	1180308,681	15	46,086674	0	6913,001099	960000	350000	5836,96489
1	2AGV	0,039	61,05616945		5,76	208289,7672	0	0	0	0	1920000	700000	1345,803725
2	2AGV	0,12	187,8651368		13,44	486009,4567	0	0	0	0	1920000	700000	2267,42976
3	2AGV	0,98	1534,23195	not WS	29,76	1076163,797	15	74,42264966	0	11163,39745	1920000	700000	8822,315059
4	2AGV	6,815216	10669,51238		175,68	6352837,898	22	124,4102467	0	18661,53701	1920000	700000	12699,05887
5	2AGV	0,446	698,2320917		31,68	1145593,719	1	0,226125062	0	33,9187593	1920000	700000	5936,639386
1	1AMR	0,087	136,2022242		4,8	173574,806	0	0	13,85493827	2078,240741	84000	200000	1105,132723
2	1AMR	0,175	273,9699911		10,56	381864,5731	0	0	21,62043418	3243,065126	84000	200000	1667,270477
5	1AMR	0,795	1244,606531		18,24	659584,2626	15	46,64505236	90,5437047	20578,31356	84000	200000	4270,029005
1	2AMR	0,071	111,1535393		4,8	173574,806	0	0	13,85493827	2078,240741	168000	400000	1081,501286
2	2AMR	0,131	205,0861077		10,56	381864,5731	0	0	21,62043418	3243,065126	168000	400000	1650,900096
5	2AMR	0,451	706,0598057		18,24	659584,2626	1	1,508683656	90,5437047	13807,85825	168000	400000	4137,21769

Favorable Scenario

Scenario	Robot	Total Average WIP	Cost WIP (Kr) /year	Feasible space pallets	Space needed	Cost m^2 (kr)	Worforce (days)	Workforce (hours)	Workforce (moving pallets to picking point)	Cost operator (Kr)	Cost robot (kr)	Cost implementation	cost electricity
1	1AGV	0,062	97,063654		5,76	312434,6507	0	0	0	0	640000	350000	2090,78807
2	1AGV	0,195	305,2808473		11,52	624869,3015	0	0	0	0	640000	350000	3433,819392
3	1AGV	1,864	2918,171791		73,92	4009578,018	57	303,777135	0	45566,57025	640000	350000	11071,98824
4	1AGV	6,385	9995,990819	not WS	119,04	6456982,782	100	483,920963	0	72588,14444	640000	350000	15253,36635
5	1AGV	0,983	1538,928579		32,64	1770463,021	15	46,086674	0	6913,001099	640000	350000	8755,447334
1	2AGV	0,039	61,05616945		5,76	312434,6507	0	0	0	0	1280000	350000	2018,705587
2	2AGV	0,12	187,8651368		13,44	729014,185	0	0	0	0	1280000	350000	3401,14464
3	2AGV	0,98	1534,23195		29,76	1614245,695	15	74,42264966	0	11163,39745	1280000	350000	13233,47259
4	2AGV	6,815216	10669,51238	not WS	175,68	9529256,847	22	124,4102467	0	18661,53701	1280000	350000	19048,5883
5	2AGV	0,446	698,2320917		31,68	1718390,579	1	0,226125062	0	33,9187593	1280000	350000	8904,959078
1	1AMR	0,087	136,2022242		4,8	260362,2089	0	0	13,85493827	2078,240741	56000	200000	1657,699085
2	1AMR	0,175	273,9699911		10,56	572796,8597	0	0	21,62043418	3243,065126	56000	200000	2500,905715
5	1AMR	0,795	1244,606531		18,24	989376,394	15	46,64505236	90,5437047	20578,31356	56000	200000	6405,043507
1	2AMR	0,071	111,1535393		4,8	260362,2089	0	0	13,85493827	2078,240741	112000	200000	1622,25193
2	2AMR	0,131	205,0861077		10,56	572796,8597	0	0	21,62043418	3243,065126	112000	200000	2476,350144
5	2AMR	0,451	706,0598057		18,24	989376,394	1	1,508683656	90,5437047	13807,85825	112000	200000	6205,826534

Planificación temporal y presupuesto

A continuación, se va a presentar la planificación temporal del proyecto desarrollado de una forma visual siguiendo el orden cronológico de los eventos.

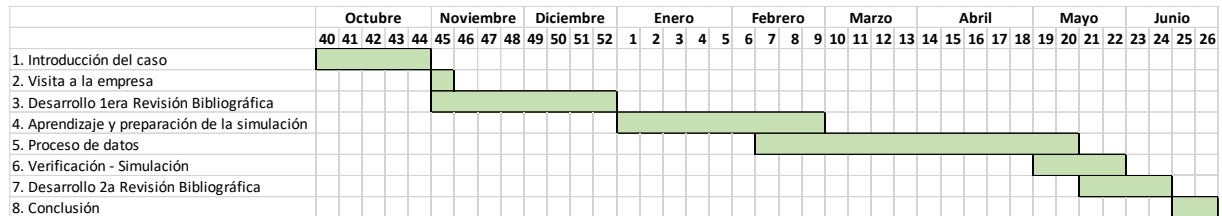

Con un total de 9 meses trabajados a jornada laboral de 8 horas por día sin contar los fines de semana.

Con esta información se puede desglosar el presupuesto del proyecto desarrollado. En este presupuesto se incluirá los costes por las horas trabajadas más el coste invertido para poder visitar la compañía.

Las hipótesis usadas son:

1. 20 días laborables por mes
2. 8 horas por día laboral
3. Salario noruego de un ingeniero en los primeros años de trabajo o en PhD: 30 euros/hora (antes de impuestos)

Con toda esta información, se construye el presupuesto:

Entrada	Coste (€)
Coste Visita	500
Coste Ingeniero	43200
Total	43700

Este proyecto tiene un presupuesto de 43.700 euros por un total de 1440 horas.

Images

<i>Image 1 Food supply chain characteristics (A. Romsdal 2014)</i>	9
<i>Image 2 Comparison Chart of Navigation methods (MHI org)</i>	13
<i>Image 3 Comparison table between AGV and AMR</i>	14
<i>Image 4 Systematic literature review method</i>	19
<i>Image 5 Characteristics AVG and ARM (N. Hornàkova 2019)</i>	25
<i>Image 6 Systematic literature review method</i>	30
<i>Image 7 Layout Company X</i>	39
<i>Image 8 Layout Company X</i>	40
<i>Image 9 Visual Legend</i>	45
<i>Image 10 Material Flow Sugar 1</i>	45
<i>Image 11 Material Flow Sugar 2</i>	45
<i>Image 12 Material Flow Sugar 3</i>	46
<i>Image 13 Material Flow Sugar 4</i>	46
<i>Image 14 Spaghetti diagram Sugar 1</i>	47
<i>Image 15 Spaghetti diagram Sugar 2</i>	48
<i>Image 16 Spaghetti diagram Sugar 3</i>	49
<i>Image 17 Spaghetti diagram Sugar 4</i>	50
<i>Image 18 Kilograms produced monthly</i>	52
<i>Image 19 Pallets produced monthly</i>	53
<i>Image 20 Raw material Pallets Needed monthly</i>	53
<i>Image 21 Packaging Material Pallets Needed monthly</i>	53
<i>Image 22 Material flow Scenario 1</i>	54
<i>Image 23 Material Flow Scenario 2</i>	54
<i>Image 24 Material Flow Scenario 3</i>	55
<i>Image 25 Material Flow Scenario 4</i>	55
<i>Image 26 Material Flow Scenario 5</i>	55
<i>Image 27 Location Picking Point AMR scenarios</i>	56
<i>Image 28 Matrix of Return flow</i>	58
<i>Image 29 Equations empty trips</i>	59
<i>Image 30 Layout displayed in AutoMod</i>	61

Tables

<i>Table 1 Articles Selection</i>	24
<i>Table 2 Benefits comparison between AVG and ARM</i>	26
<i>Table 3 Limitation comparison between AVG and ARM</i>	26
<i>Table 4 Articles Selection</i>	34
<i>Table 5 Product Portfolio</i>	38
<i>Table 6 Layout Description Company X</i>	41
<i>Table 7 Production (tons/week) of each family type</i>	41
<i>Table 8 From-To Chart Example Scenario 4</i>	57
<i>Table 9 From to Chart per hour</i>	58
<i>Table 10 Days covered by the Robot</i>	60
<i>Table 11 Days when workforce is required</i>	60
<i>Table 12 Days covered by the Robot</i>	60
<i>Table 13 Days when workforce is required</i>	60
<i>Table 14 Diference between Scenarios</i>	64
<i>Table 15 Costs incurred in Neutral Scenario</i>	64
<i>Table 16 Costs incurred in unfavorable Scenario</i>	65
<i>Table 17 Costs incurred in Favorable Scenario</i>	65

References

- Farah Bader, Shahin Rahimifard (2018). Challenges for Industrial Robot Applications in Food Manufacturing. ISCSIC '18, September 21–23, Stockholm, Sweden.
- Darwin G. Caldwell. Robotics and Automation in the Food Industry: Current and Future Technologies. Woodhead Publishing Limited, 2013. Philadelphia, PA 19102-3406, USA
- Jiafu Wan, Shenglong Tang, Qingsong Hua, Di Li, Chengliang Liu, and Jaime Lloret (2018). Context-Aware Cloud Robotics for Material Handling in Cognitive Industrial Internet of Things. IEEE INTERNET OF THINGS JOURNAL, VOL. 5, NO. 4.
- F.Jovanea, Y.Koren, C.R.Boëra (2003). Present and Future of Flexible Automation: Towards New Paradigms. CIRP Annals **52**, 543-560
- Henrik Ringsberg (2014). Perspectives on food traceability: a systematic literature review. Supply Chain Management. An International Journal 19/5/6 ,558–576
- David Tranfield, David Denyer and Palminder Smart (2003). Towards a Methodology for Developing Evidence-Informed Management Knowledge by Means of Systematic Review. British Journal of Management, Vol. 14. 207-222
- Can Eksoz, S. Afshin Mansouri, Michael Bourlakis (2014). Collaborative forecasting in the food supply chain: A conceptual framework. Int. J.Production Economics 158, 120–135
- Domenico Falcone, Alessandro Silvestri, Vincenzo Duraccio, Gianpaolo Di Bona (2011). Material Flow Map and Layout Optimization: action plan and software validation.
- Lixia Chen, Bo Meng (2010). The Application of Value Stream Mapping Based Lean Production System. International Journal of Business and Management. Vol. 5, No. 6
- E. Jiménez , A. Tejada , M. Pérez , J. Blanco & E. Martínez (2012) Applicability of lean production with VSM to the Rioja wine sector, International Journal of Production Research, 50:7, 1890-1904, DOI: 10.1080/00207543.2011.561370
- Barsing, Prashant & Daultani, Yash & Vaidya, Omkarprasad & Kumar,, Sushil. (2018). Cross-docking Centre Location in a Supply Chain Network: A Social Network Analysis Approach. Global Business Review. 19. 097215091875784. 10.1177/0972150918757847.
- Van der Vorst, Jack. (2000). Effective food supply chains; generating, modelling and evaluating supply chain scenarios. Wageningen Universiteit. Promotor: prof.ir. A.J.M. Beulens n prof.dr. P. van Beek. - Wageningen : Vorst, 2000. - ISBN 90 5808 26 -X.
- Jovane, Francesco & Koren, Yoram & Boer, Claudio. (2003). Present and Future of Flexible Automation: Towards New Paradigms. CIRP Annals - Manufacturing Technology. 52. 543-560. 10.1016/S0007-8506(07)60203-0.
- Ahumada, Omar & Villalobos, J.. (2009). Application of Planning Models in the Agri-Food Supply Chain: A Review. European Journal of Operational Research. 196. 1-20. 10.1016/j.ejor.2008.02.014.
- Romsdal, Anita & Strandhagen, Jan Ola & Dreyer, Heidi. (2014). Can Differentiated Production Planning and Control enable both Responsiveness and Efficiency in Food Production?. 10.18461/ijfsd.v5i1.514.
- Onut, Semih & Kara, Selin & Mert, Sinan. (2009). Selecting the suitable material handling equipment in the presence of vagueness. The International Journal of Advanced Manufacturing Technology. 44. 818-828. 10.1007/s00170-008-1897-3.
- Winkelhaus, Sven & Grosse, Eric. (2019). Logistics 4.0: a systematic review towards a new logistics system. International Journal of Production Research. 10.1080/00207543.2019.1612964.

Stefansson, Gunnar, and Kenth Lumsden. (2008) "Performance Issues of Smart Transportation Management Systems." *International Journal of Productivity and Performance Management* 58 (1): 55–70. doi:10.1108/17410400910921083

Mena, Carlos & Stevens, Graham. (2010). *Delivering Performance in Food Supply Chains*. 10.1533/9781845697778.1.

Romsdal, Anita. (2014). Differentiated production planning and control in food supply chains.

Septiani, Winnie & Astuti, Pudji. (2017). Identifying research advancements in supply chain risk management for Agri-food Industries: Literature review. *IOP Conference Series: Materials Science and Engineering*. 277. 012064. 10.1088/1757-899X/277/1/012064.

C.A. Soman et al. / *Int. J. Production Economics* 90 (2004) 223–235:

Manzini, Riccardo & Accorsi, Riccardo. (2013). The new conceptual framework for food supply chain assessment. *Journal of Food Engineering* 115 (2): 251-263.

Jonkman, Jochem & Bloemhof-Ruwaard, Jacqueline & Van der Vorst, Jack & van der Padt, Albert. (2016). Selecting food process designs from a supply chain perspective. *Journal of Food Engineering*. 195. 10.1016/j.jfoodeng.2016.09.015.

Nakandala, Dilupa & Lau, H.C.W.. (2018). Innovative adoption of hybrid supply chain strategies in urban local fresh food supply chain. *Supply Chain Management: An International Journal*. 10.1108/SCM-09-2017-0287.

Sven Winkelhaus & Eric H. Grosse (2019): Logistics 4.0: a systematic review towards a new logistics system, *International Journal of Production Research*, DOI: 10.1080/00207543.2019.1612964

Estefanía , José Antonio and Ramos, Benjamín. (2013). Warehouse logistics from casbega point of view *Proceedings. IEEE 9th International Conference on Intelligent Computer Communication and Processing, ICCP 2013*.

Kay, Michael G. (2012). *Material Handling Equipment*

Andrew Kusiak (2018) Smart manufacturing, *International Journal of Production Research*, 56:1-2, 508-517, DOI: 10.1080/00207543.2017.1351644

Vikas Gupta, et. al., "A Review Onmaterial Handling Equipment and their Selection for Potential Applications", *International Journal of Technical Research (IJTR)*, Volume 2, Issue 1, pp 51-54, 2013.

Chunjie Wang, Dandan Du. (2016). Research on Logistics Autonomous Mobile Robot System. *IEEE International Conference on Mechatronics and Automation*, Article number 7558574, 275-280.

A. Liaqat, W. Hutabarat, D. Tiwari, L. Tinkler, D. Harra, B. Morgan, A. Taylor, T. Lu & A. Tiwari. (2019). Autonomous mobile robots in manufacturing: Highway Code development, simulation, and testing. *The International Journal of Advanced Manufacturing Technology*, 104, 4617–4628.

Nicol Naidoo, Glen Bright, Riaan Stopforth. (2019). A Distributed Framework for Programming the Artificial Intelligence of Mobile Robots in Smart Manufacturing Systems. *IEEE*.

Centers. Marco Bonini, Domenico Prenesti, Augusto Urru, Wolfgang Echelmeyer. (2015). Towards the Full Automation of Distribution. *4th IEEE International Conference on Advanced logistics and Transport*.

Yudi Fernando, Anas Mathath, Mohsen Ali Murshid. (2016). Improving Productivity: A Review of Robotic Applications in Food Industry. *International Journal of Robotics Applications and Technologies*, 4, (1).

Mohammed Faisal, Mohammed Algabri, Bencherif Mohamed Abdelkader, Habib Dhahri, And Mohamad Mahmoud Al Rahhal. (2017). Human Expertise in Mobile Robot Navigation. *IEEE* , 6, 1694-1705.

- Hanns de la Fuente-Mella, José Luis Riojas Fuentes & Victor Leiva. (2019). Econometric modeling of productivity and technical efficiency in the Chilean manufacturing industry. *Computers & Industrial Engineering*
- Wenting Zhan. Wei Pan. (2019). An Efficiency-orientated Total Factor Productivity Measurement Model for Construction Projects. MOC Summit.
- Seohyun Jeon, Jaeyeon Lee and Jaehong Kim. (2017). Multi-Robot Task Allocation for Real-Time Hospital Logistics. *IEEE International Conference on Systems, Man, and Cybernetics (SMC) Banff Center, Banff, Canada*
- Hadi Ardiny, Stefan Witwicki, Francesco Mondada. (2015). Construction Automation with Autonomous Mobile Robots: A Review. *Proceedings of the 3rd RSI International Conference on Robotics and Mechatronics October 7-9, 2015, Tehran, Iran*
- B. Satish Kumar, G. Janardhana Raju & G. Rangajanardhana. (2018). Performance Analysis Of Different Material Handling Devices In Flexible Manufacturing System. *International Journal of Mechanical and Production Engineering Research and Development (IJMPERD) Vol. 8 (6), 425-436*
- Alberto Vale, Daniel Fonte, Filipe Valente, Isabel Ribeiro. (2014). Trajectory optimization for autonomous mobile robots in ITER. *Robotics and Autonomous Systems Volume 62 (6), 871-888*
- Horn, Natá & Luká, • & Jurík, Lukáš & Hrablik, Henrieta & Cagá, Dagmar & Babčanová, Dagmar. (2019). AHP method application in selection of appropriate material handling equipment in selected industrial enterprise. *Wireless Networks*. 10.1007/s11276-019-02050-2(.
- Bloss, Richard. (2011). Automation meets logistics at the Promat Show and demonstrates faster packing and order filling. *Assembly Automation*. 31. 315-318. 10.1108/01445151111172880.
- Ferreira, Tremaine & Gorch, I.A.. (2016). Development of an automated guided vehicle controller using a model-based systems engineering approach. *South African Journal of Industrial Engineering*. 27. 206-217. 10.7166/27-2-1327.
- Bloss, Richard. (2013). Ease of programming and sophisticated sensors see robots advancing in transport logistics, palletizing, order picking and assembly. *Industrial Robot: An International Journal*. 40. 10.1108/IR-03-2013-335.
- Tubaileh, Allan. (2014). Layout of flexible manufacturing systems based on kinematic constraints of the autonomous material handling system. *International Journal of Advanced Manufacturing Technology*. 74. 1521-1537. 10.1007/s00170-014-6063-5.
- Faisal, Mohammed & Algabri, Mohammed & Bencherif, Mohammed & Dhahri, Habib & Alrahal, Mohamad. (2017). Human Expertise in Mobile Robot Navigation. *IEEE Access*. PP. 1-1. 10.1109/ACCESS.2017.2780082.
- Culler, David & Long, James. (2016). A Prototype Smart Materials Warehouse Application Implemented Using Custom Mobile Robots and Open Source Vision Technology Developed Using EmguCV. *Procedia Manufacturing*. 5. 1092-1106. 10.1016/j.promfg.2016.08.080.
- Bačík, Ján & Durovsky, Frantisek & Biros, Milan & Kyslan, Karol & Perdukova, Daniela & Sanjeevikumar, P.. (2017). Pathfinder – Development of Automated Guided Vehicle for Hospital Logistics. *IEEE Access*. 5. 26892 - 26900. 10.1109/ACCESS.2017.2767899.
- Chadalavada, Ravi Teja & Andreasson, Henrik & Schindler, Maike & Palm, Rainer & Lilienthal, Achim. (2019). Bi-directional navigation intent communication using spatial augmented reality and eye-tracking glasses for improved safety in human-robot interaction. *Robotics and Computer-Integrated Manufacturing*. 61. 10.1016/j.rcim.2019.101830.
- Herrero-Perez, David & Villagra, Jorge & Barberá, Humberto. (2013). Self-Configuration of Waypoints for Docking Maneuvers of Flexible Automated Guided Vehicles. *IEEE Transactions on Automation Science and Engineering*. 10. 470-475. 10.1109/TASE.2013.2240386.
- Pattanayak, Suvranshu & Choudhury, Bibhuti. (2019). Modified crash-minimization path designing approach for autonomous material handling robot. *Evolutionary Intelligence*. 10.1007/s12065-019-00247-0.

- Niki Kousi, Spyridon Koukas, George Michalos & Sotiris Makris (2019) Scheduling of smart intra – factory material supply operations using mobile robots, *International Journal of Production Research*, 57:3, 801-814, DOI: 10.1080/00207543.2018.1483587
- Fazlollahtabar, Hamed & Saidi-Mehrabad, Mohammad & Masehian, Ellips. (2015). Mathematical model for deadlock resolution in multiple AGV scheduling and routing network: A case study. *Industrial Robot: An International Journal*. 42. 10.1108/IR-12-2014-0437.
- Vale, Alberto & Fonte, Daniel & Valente, Filipe & Ribeiro, Isabel. (2014). Trajectory optimization for autonomous mobile robots in ITER. *Robotics and Autonomous Systems*. 62. 10.1016/j.robot.2014.01.007.
- Azadeh, Kaveh & De Koster, René & Roy, Debjit. (2019). Robotized and Automated Warehouse Systems: Review and Recent Developments. *Transportation Science*. 53. 10.1287/trsc.2018.0873.
- Faisal, Mohammed & Mathkour, Hassan & Alsulaiman, Mansour & Zuair, Mansour. (2016). Multi-sensors multi-baseline mapping system for mobile robot using stereovision camera and laser-range device. *Advances in Mechanical Engineering*. 8. 10.1177/1687814016654634.
- Faiza Gul, Wan Rahiman & Syed Sahal Nazli Alhady | Kun Chen (Reviewing editor) (2019) A comprehensive study for robot navigation techniques, *Cogent Engineering*, 6:1, DOI: 10.1080/23311916.2019.1632046
- Tsukiyama, Toshifumi. (2011). RFID Based Navigation System for Indoor Mobile Robots. 10.3182/20110828-6-IT-1002.00990.
- AkhilaBoggavarapu1, Mr.NagarajuSonti. (2020). Implementation of RFID Robotics Based Vehicle Real Time Navigation System. *International Journal of Advanced Science and Technology*, 29(06), 3150 - 3157. Retrieved from <http://sersc.org/journals/index.php/IJAST/article/view/13877>
- Cheng, Lei. (2019). Mobile Robot Indoor Dual Kalman Filter Localization Based on Inertial Measurement and Stereo Vision. *CAAI Transactions on Intelligence Technology*. 2. 10.1049/trit.2017.0025.
- Li, Xinde. (2019). Visual Navigation Method for Indoor Mobile Robot based on Extended BoW Model. *CAAI Transactions on Intelligence Technology*. 2. 10.1049/trit.2017.0020.
- Niu, Jie & Qian, Kun. (2019). A hand-drawn map-based navigation method for mobile robots using objectness measure. *International Journal of Advanced Robotic Systems*. 16. 172988141984633. 10.1177/1729881419846339.
- Hank, Madjid & Haddad, Moussa. (2016). A hybrid approach for autonomous navigation of mobile robots in partially-known environments. *Robotics and Autonomous Systems*. 86. 10.1016/j.robot.2016.09.009.
- Shi, Haobin & Li, Xuesi & Pan, Wei & Hwang, Kao-Shing & Li, Zhixin. (2017). A novel fuzzy three-dimensional grid navigation method for mobile robots. *International Journal of Advanced Robotic Systems*. 14. 172988141771044. 10.1177/1729881417710444.
- Guo, Xiaoqing & Chu, Jinkui & Yinlong, Wang & Wan, Zhenhua & Li, Jinshan & Lin, Muyin. (2019). Formation experiment with heading angle reference using sky polarization pattern at twilight. *Applied Optics*. 58. 9331. 10.1364/AO.58.009331.
- Sherwin, Tyrone & Easte, Mikala & Chen, Andrew & Wang, Kevin & Dai, Wenbin. (2018). A Single RF Emitter-Based Indoor Navigation Method for Autonomous Service Robots. *Sensors*. 18. 585. 10.3390/s18020585.
- Zhang, Chao & Zhan, Quanzhong & Wang, Qi & Wu, Haichao & He, Ting & An, Yi. (2020). Autonomous Dam Surveillance Robot System Based on Multi-Sensor Fusion. *Sensors*. 20. 10.3390/s20041097.
- Deshpande, Nikhil & Grant, Edward & Henderson, Thomas & Draelos, Mark. (2015). Autonomous navigation using received signal strength and bearing-only pseudogradient interpolation. *Robotics and Autonomous Systems*. 75. 10.1016/j.robot.2015.10.009.

Chen, Changhao & Zhao, Peijun & Lu, Chris & Wang, Wei & Markham, Andrew & Trigoni, Niki. (2020). Deep Learning based Pedestrian Inertial Navigation: Methods, Dataset and On-Device Inference.

Nirmal, Paramesh & Lyons, Damian. (2015). Homing with stereovision. *Robotica*. 1-18. 10.1017/S026357471500034X.

Lin, Chun-Hui & Wang, Shyh-Hau & Lin, Cheng-Jian. (2018). Interval Type-2 Neural Fuzzy Controller-Based Navigation of Cooperative Load-Carrying Mobile Robots in Unknown Environments. *Sensors*. 18. 4181. 10.3390/s18124181.

Nattharith, Panus & Guzel, Mehmet. (2016). Machine vision and fuzzy logic-based navigation control of a goal-oriented mobile robot. *Adaptive Behavior*. 24. 10.1177/1059712316645845.

Pang, Ming & Meng, Zhankai & Zhang, Wenbo & Ru, Changhai. (2016). MGRO Recognition Algorithm-Based Artificial Potential Field for Mobile Robot Navigation. *Journal of Sensors*. 2016. 1-7. 10.1155/2016/1959160.

Faisal, Mohammed & Mathkour, Hassan & Alsulaiman, Mansour & Zuair, Mansour. (2016). Multi-sensors multi-baseline mapping system for mobile robot using stereovision camera and laser-range device. *Advances in Mechanical Engineering*. 8. 10.1177/1687814016654634.

Cviklovič, Vladimír & Olejár, Martin & Hrubý, Dušan & Palkova, Zuzana & Lukáč, Ondrej & Hlaváč, Peter. (2016). Navigation Algorithm Using Fuzzy Control Method in Mobile Robotics. *Acta Technologica Agriculturae*. 19. 10.1515/ata-2016-0004.

Akai, Naoki & Morales, Y. & Murase, H.. (2018). Teaching-Playback Navigation Without a Consistent Map. *Journal of Robotics and Mechatronics*. 30. 591-597. 10.20965/jrm.2018.p0591.

Lvwen Huang, Dongjian He, Zhiyong Zhang & Peng Zhang (2016): Path Navigation For Indoor Robot With Q-Learning, *Intelligent Automation & Soft Computing*, DOI: 10.1080/10798587.2015.1095485

khanh hoa, Dang & Duc, T.V. & Hoang, Vu & Tung, Vu & Nguyen, Tien. (2018). An effective depth map navigation for mobile robot in indoor environments. *JP Journal of Heat and Mass Transfer*. 15. 221-237. 10.17654/HMSI218221.

Khalilullah, K. M. Ibrahim & Ota, Shunsuke & Yasuda, Toshiyuki & Jindai, Mitsuru. (2018). Road area detection method based on DBNN for robot navigation using single camera in outdoor environments. *Industrial Robot: An International Journal*. 10.1108/IR-08-2017-0139.

Zou, Qiang & Cong, Ming & Liu, Dong & Du, Yu. (2019). Robotic Path Planning Based on Episodic-cognitive Map. *International Journal of Control, Automation and Systems*. 17. 10.1007/s12555-018-0141-7.

Chen, Weina & Zeng, Qinghua & Liu, Jianye & Wang, Huizhe. (2017). Seamless autonomous navigation based on the motion constraint of the mobile robot. *Industrial Robot: An International Journal*. 44. 178-188. 10.1108/IR-06-2016-0171.

Zhao, Xu & Dou, Lihua & Su, Zhong & Liu, Ning. (2018). Study of the Navigation Method for a Snake Robot Based on the Kinematics Model with MEMS IMU. *Sensors*. 18. 879. 10.3390/s18030879.

Kraft, Marek & Nowicki, Michał & Schmidt, Adam & Fularz, Michał & Skrzypczyński, Piotr. (2016). Toward evaluation of visual navigation algorithms on RGB-D data from the first- and second-generation Kinect:. *Machine Vision and Applications*. 10.1007/s00138-016-0802-6.

MHI org: <https://www.mhi.org/>

MiR, 2020: <https://www.mobile-industrial-robots.com/en/solutions/robots/>

Electricity cost: <https://www.statista.com/statistics/596381/electricity-household-price-norway/#:~:text=Norwegian%20household%20consumers%20have%20seen,lower%20than%20%2C500%20kilowatt%20hours.>

Average Salary:

<http://www.salaryexplorer.com/salariesurvey.php?loc=162&loctype=1&job=33&jobtype=1>

Cost robots: <https://www.agvnetwork.com/agv-vs-amr>

Meyer, Christine Benedichte. (2001). A Case in Case Study Methodology. Sage Journals. *Field Methods*, Vol. 13, No. 4, 329–352.

Hajjar, Dany & Abourizk, Simaan. (1996). Building a special purposes simulation tool for earth moving operations. Winter Simulation Conference Proceedings. 1313-1320. 10.1145/256562.256955.

