

Adel Ramadan

Energy optimization of offshore gas installation

Master's thesis in Natural Gas Technology

Supervisor: Lars O. Nord

Co-supervisor: Even Solbraa, Marlene Louise Lund

March 2021

Adel Ramadan

Energy optimization of offshore gas installation

Master's thesis in Natural Gas Technology
Supervisor: Lars O. Nord
Co-supervisor: Even Solbraa, Marlene Louise Lund
March 2021

Norwegian University of Science and Technology
Faculty of Engineering
Department of Energy and Process Engineering



EPT-M-2020

MASTER'S THESIS

for

Student Adel Ramadan

Fall 2020

English title:

Energy optimization of offshore gas installation**Background and objective**

The attempt to reduce the environmental impact of oil and gas installations has been the driver for researching energy efficient process solutions and to supply energy offshore. In addition, the EU has set an ambitious target to reach carbon neutrality by 2050, which pushed energy companies to draw the roadmap that would lead them to that goal. Previous studies have either focused on the process side (energy demand side), or on the heat and power generation side (energy supply side). This project will jointly consider the supply and demand sides to achieve an energy optimized solution that minimizes the energy related CO₂ emissions of the installation. How can the energy demand and supply sides be optimally matched to minimize the CO₂ emissions? Can novel process designs and configurations be employed? What solutions on the heat and power generation can improve the energy efficiency? How much closer can we get to carbon neutrality after implementing these solutions?

The main objective of the thesis is to design and evaluate an optimum solution for an offshore installation by jointly considering both energy supply and demand sides.

The following tasks are to be considered:

1. Literature review on offshore heat and power generation, and the gas processes.
2. Evaluate possible processes and process configurations and pinpoint the most promising ones for the selected case study.
3. Design the offshore systems and build process model(s) of the systems in Aspen HYSYS for the selected case study.
4. Perform process simulations of the concepts, conduct energy optimization, critically analyse the performance, and compare to a reference case.

Academic supervisor:

Lars O. Nord, NTNU

Co-supervisors:Even Solbraa, NTNU and Equinor
Marlene Louise Lund, Equinor

Acknowledgments

Because of the worldwide public health emergency caused by the outbreak of COVID-19, it was not possible for me to be present in NTNU's campus in Trondheim for the duration of my research. This made the whole process of writing my master's thesis all the more challenging because I was not surrounded by the proper working environment, which sometimes resulted in a feeling of disconnection from my work and a lack of motivation. Nevertheless, I was extremely fortunate to have the support of several persons, even if from a distance, which kept me moving forward at every step of the way. To these persons, I would love to express my sincere gratitude.

First and foremost, I would like to thank my main supervisor at NTNU, Associate Professor Lars Olof Nord, to whom I have reached out and expressed my interest in the research fields in which he is involved. From start to finish, he never missed a chance to provide me with insightful input to complement my research, all while showing a high level of trust in the work that I was doing. I would also like to thank him for the effort he had put in to help me with the bureaucratic hurdles for my enrolment at NTNU that had to be handled remotely, and for making this experience the best that it can ever be.

I would also like to give special thanks to my co-supervisors at Equinor, Professor Even Solbraa and Marlene Louise Lund, who constantly showed readiness in providing assistance and guidance for the technical parts of my work. Not to forget my supervisor at Politecnico di Torino, Associate Professor Giovanni Andrea Blengini, for raising my interest in topics related to the scope of this master's thesis.

To my friends in Beirut and in Turin, I express my appreciation for constantly pushing me forward and for being my personal escape whenever I was overwhelmed with work and felt the need for a breath of fresh air.

Finally, to my parents and sister. For their unconditional love and understanding, for their faith and trust in me, for showing interest and support in everything that I do, and for their constant sacrifices that allowed me to achieve my dreams and be where I am today. They are my true backbone and my ultimate source of inspiration in life.

Abstract

The attempt to reduce the environmental impact of offshore gas installations has been the main driver for research in process energy efficiency and energy supply concepts. On the one hand, offshore gas processing is an energy intensive activity, and therefore a major source for energy related CO₂ emissions. On the other hand, a fair share of the current energy supply methods emit a considerable amount of CO₂ from power and heat generation. Therefore, striking a balance between process optimizations and relying on cleaner energy supply sources is the key to achieving the desired environmental goals.

This study focuses on evaluating the environmental impact of several energy supply methods, namely a gas turbine, a combined cycle, and electricity from the onshore power grid, to determine the concept that exhibits the lowest cumulative CO₂ emissions over the gas field's production lifetime. Platform electrification was presented as the best energy supply alternative from the environmental point of view with a potential CO₂ emissions savings of up to 85.8%. To optimize the setup even further, an innovative internal heat recovery system from the process fluids using heat exchangers was simulated. The results showed that emission savings potential could be increased from 85.8% to 86.6%, validating the advantages of the proposed setup.

The main challenge for the development of the process design configurations and the comparison of the proposed setups is the differences between the primary energy sources involved, each with its own key performance indicators. Therefore, the chosen basis for comparison was the carbon emission factor for electricity generation in the case of platform electrification, and the net plant efficiency for the scenarios involving a gas turbine and a combined cycle, which is directly proportional to the amount of natural gas consumed and hence, the amount of CO₂ emitted from each of the two technologies.

Table of Contents

Acknowledgments	I
Abstract	III
Table of Contents	V
List of figures	VIII
List of tables	X
Nomenclature	XII
1. Introduction	2
1.1. Background	2
1.2. Motivation	2
1.3. Objectives	3
1.4. Contribution.....	4
1.5. Methodology	4
1.5.1. Collection of information on gas processing.....	5
1.5.2. Aspen HYSYS process simulation design.....	5
1.5.3. CO ₂ emission evaluation	6
1.6. Thesis outline	7
2. Environmental background	8
2.1. Climate change	8
2.2. The role of natural gas in clean energy transition	9
2.3. The role energy efficiency in clean energy transition	11
3. Offshore oil and gas platforms	13
3.1. Description of the platform and system boundaries	13
3.2. Natural gas processing.....	14
3.2.1. Oil and condensate removal	15
3.2.2. Water removal	16
3.2.3. Sour gas removal	17
3.3. Process components.....	17
3.3.1. Separators	17
3.3.2. Compressors	18
3.3.3. Pumps:	19
3.3.4. Heat exchangers:	20
4. Power and heat supply offshore	22

4.1.	Gas turbines	22
4.1.1.	General definitions	22
4.1.2.	Combustion of fuel in a gas turbine.....	24
4.1.3.	Gas turbine cooling.....	25
4.2.	Heat recovery	25
4.2.1.	Cogeneration.....	27
4.2.2.	Combined cycles	29
4.2.2.1.	Steam bottoming cycles.....	30
4.2.2.2.	Organic rankine bottoming cycles.....	31
4.3.	Electrification	32
4.4.	Performance indicators.....	33
4.4.1.	Source to Site ratio	33
4.4.2.	Net plant efficiency	34
4.4.3.	Carbon emission factor.....	35
5.	Case study.....	37
5.1.	Process data	37
5.2.	Scenarios	41
5.3.	Assumptions	41
6.	Results and discussions	43
6.1.	Energy supply determination.....	43
6.1.1.	Process description and results.....	43
6.1.2.	Process energy demands.....	52
6.1.3.	Carbon dioxide emissions.....	53
6.2.	Process optimization.....	55
6.2.1.	Process description and results	56
6.2.2.	Process energy requirements	59
6.2.3.	Carbon dioxide emissions.....	60
6.3.	Limitations.....	61
7.	Conclusion and future works.....	63
7.1.	Conclusion.....	63
7.2.	Future works.....	64
	Bibliography	65
	Appendix A	70

List of figures

Figure 1.1: Workflow to generate process design configurations in Aspen HYSYS	6
Figure 2.1: CO ₂ savings from coal-to-gas switching compared to 2010	10
Figure 2.2: CO ₂ abatement by technology to reach sustainable development scenario ...	11
Figure 3.1: Schematic of the different blocks of an offshore gas installation	13
Figure 3.2: Gas treatment plant schematic.....	15
Figure 4.1: Simplified schematic of a gas turbine	23
Figure 4.2: Effect of TIT on gas turbine efficiency	23
Figure 4.3: Simplified schematic of a recuperated gas turbine.....	24
Figure 4.4: Schematic of a gas turbine topping cycle couple with a WHRU	28
Figure 4.5: Simplified schematic of a combined power cycle.....	29
Figure 4.6: Drum-type HRSG.....	31
Figure 4.7: Share of renewable power in energy generation worldwide	36
Figure 6.1: Generated process design configuration in Aspen HYSYS	44
Figure 6.2: Phase envelope of the rich gas stream exiting the inlet separator	45
Figure 6.3: Phase envelope of the rich gas stream exiting the first stage scrubber	46
Figure 6.4: Phase envelope of the rich gas stream exiting the second stage scrubber.....	47
Figure 6.5: Source energy and site energy of the three simulations	52
Figure 6.6: Cumulative CO ₂ emissions of the proposed energy supply concepts.....	54
Figure 6.7: Process configuration of the optimized case	57
Figure 6.8: Source and site energy of PFS and PFS+HX	59
Figure 6.9: Cumulative CO ₂ emissions of PFS and PFS+HX	60

List of tables

Table 4.1: Temperature ranges of waste heat and their share from the total	26
Table 5.1: Initial well stream composition	38
Table 5.2: Properties of the hypo components contained in the well stream.	39
Table 5.3: Production profile of the offshore gas installation	40
Table 6.1: Product export from the offshore gas installation.....	50
Table 6.2: Composition of export products	51
Table 6.3: Fluids inlet and outlet temperatures from the heat exchangers	58

Nomenclature

GHG	Greenhouse gas
GT	Gas Turbine
HRSG	Heat recovery steam generator
HX	Heat exchanger
LHV	Lower heating value
NGL	Natural gas liquids
ORC	Organic Rankine cycle
OTSG	Once through steam generator
PFS	Power from shore
SC	Steam cycle
TEG	Triethylene glycol
TIT	Turbine inlet temperature
TVP	True Vapor pressure
WHR	Waste heat recovery
WHRU	Waste heat recovery unit

1. Introduction

1.1. Background

In November 2018, the European commission established a vision to reach an economy with net-zero greenhouse gas emissions, which was later endorsed by the European Parliament in March 2019 [1]. This transition poses an urgent challenge as well as an unprecedented opportunity to build a better future for the whole society [1]. To reach this ambitious goal, all parts of the society along with the different economic sectors, including industry, power, mobility and agriculture, must contribute their efforts. National strategies have then been developed to reach this target, pushing public and private companies to redraw their roadmaps in order to reach this goal. Specifically, oil and gas companies have been in the spotlight since then, due to their notorious reputation of being the main drivers of climate change, whether it is with the products that they provide, or the means by which they provide them. When it comes to the products that these companies provide, namely oil and natural gas, it is becoming more and more evident that these fuel sources are going to be an integral part of the energy supply mix for decades to come despite continuous efforts to cut greenhouse gas emissions [2]. This is because oil and natural gas offer an advantage in terms of efficiency and reliability compared to other energy supply sources such as renewable energy. What is left is therefore attempting to minimize the environmental impact of producing these fossil fuels. This has been the main driver for research aiming to find alternative solutions for the supply of energy for oil and gas installations, and to increase energy efficiency of the processes involved in oil and gas extraction and processing. The scope of this master's thesis falls under the topic of reducing energy consumption of offshore oil and gas processing units and therefore energy related CO₂ emissions, and aims to provide insightful contribution in this research area.

1.2. Motivation

Since the beginning of the industrial revolution, worldwide energy consumption has been increasing at an exponential level. Also, during this period, standards of living throughout

the globe improved drastically due to unprecedented human and technological developments, and a link between energy use and quality of life was observed [3].

Fossil fuels were, still are, and will remain one the main constituents of the energy supply mix for most industrial and economic activities. However, with the continuous consumption of fossil fuels, greenhouse gas emissions around the world were constantly reaching all-time highs. The correlation between energy consumption and GHG concentration in the atmosphere presented a dilemma of whether to prioritize human and technological development by keeping up with the increasing energy consumption trend, or the preservation of the environment. This problem can be overcome by decoupling energy consumption from human development to ensure a constant improvement of the quality of living, while minimizing the environmental impact of energy intensive practices. Increasing the energy efficiency of industrial and economic activities, as well as using alternative energy supply sources that emit lower amounts of GHG into the atmosphere are two of the main focus points to reach this end goal [3].

The author's motivation to write this master's thesis therefore lies in the ambition of joining the efforts to reach an environmentally conscious approach concerning energy supply and demand, and therefore guarantee a constant advancement in human development worldwide.

1.3. Objectives

The main objective of this master's thesis is to present an energy optimized solution that minimizes energy related CO₂ emissions of an offshore gas installation by jointly considering energy supply alternatives in addition to process design optimizations. With the object of achieving the desired results, the following tasks are considered:

- Literature review on natural gas processing and treatment, as well as offshore heat and power supply methods.
- Shortlisting the most promising methods of energy supply for the selected case study.

- Designing an offshore natural gas processing system and building a process model in Aspen HYSYS that produces both rich gas and condensate that meet product export specifications.
- Fitting the shortlisted energy supply methods to the designed process and comparing their energy related CO₂ emissions.
- Performing process optimization to minimize energy demands of the system and therefore proposing a system setup with the lowest cumulative CO₂ emissions over the production lifetime of the field.

Once these tasks have been completed, the objectives of this master's thesis shall be satisfied, and an optimized setup is presented.

1.4. Contribution

Previous research has focused either exclusively on the process side (energy demand), by optimizing oil and gas processing units and therefore minimizing their energy consumption, or on the heat and power generation side (energy supply side), by developing innovative systems and presenting new concepts for energy supply offshore. This master's thesis combines these two topics to provide a more complete overview for a potential system setup of an offshore gas processing unit that maximizes CO₂ emissions savings. Hence, this paper will look deeply into the opportunities and limitations of the different energy supply methods for offshore gas installations and present potential process optimizations that fit into a specific energy supply method with reference to a specific case study. The findings of this master's thesis will therefore show that a thorough assessment of individual scenarios can further improve the overall performance of a proposed setup and that adapting a similar approach would yield finer results in future studies related to this research area.

1.5. Methodology

To meet the objective of this research paper, process design configurations with the lowest energy requirements had to be created using Aspen HYSYS starting from the provided gas field data. The result should be to determine the setup with the lowest CO₂ emissions over

its production lifetime. Therefore, the workflow is divided into three main tasks consisting of background information on energy supply technologies and natural gas processing, translating the knowledge gained in a design simulation using Aspen HYSYS, and finally proposing a setup with the lowest carbon emissions for the case study. The approach taken to satisfy each of the tasks is presented in the following subsections.

1.5.1. Collection of information on gas processing

All the necessary knowledge concerning gas processing in offshore platforms was acquired through literature review and by collecting information from recorded natural gas technology courses at NTNU. A review on the fundamentals of thermodynamics was also deemed necessary in order to facilitate the simulation of the process design configuration and the manual optimizations that followed. Since offshore gas-processing system configurations vary from field to field and are dependent on the composition of the produced streams, only conceptual information was retrieved from literature, upon which the simulation of the process design was based and fitted into the case study involved.

1.5.2. Aspen HYSYS process simulation design

In order to design the optimal configuration for the processing of the natural gas stream, an iterative approach was adapted in order to refine the design to the furthest extent possible. Unfortunately, the use of the optimizer tool in Aspen HYSYS was not useful in this regard since the decisive variables to be fixed (True Vapor Pressure at 37°C for oil export and cricondenbar pressure for gas export) were not supported. To overcome this limitation, process data was compiled in a table and the total energy requirements were manually monitored until the optimal results where overall energy requirements are lowest were reached.

The parameters that were constantly manipulated were mostly the temperatures and pressures of the material streams and the compression ratios of the compressors, which determined the number of compression and recompression stages. Figure 1.1 illustrates the workflow adapted for the simulation of the process designs with the lowest energy requirements.

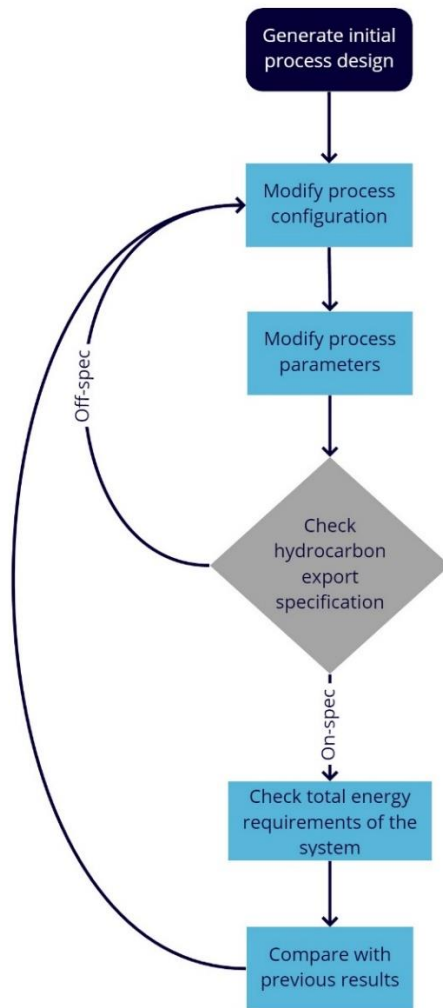

Figure 1.1: Workflow to generate process design configurations in Aspen HYSYS.

1.5.3. CO₂ emission evaluation

For each of the simulated process designs, cumulative CO₂ emissions were computed and compared based on information gathered from literature on carbon emissions of different energy supply methods to determine the scenario with the lowest CO₂ emissions.

1.6. Thesis outline

This master's thesis is divided into seven chapters (introduction included) and an appendix, providing background information on the topic at hand and presenting the work done to achieve the objectives of this research.

In Chapter 2, an environmental background is provided to give an overview of the current challenges and their relationship with the topic of this master's thesis. Chapter 3 discusses offshore oil and gas installations and puts an emphasis on the gas processing block, with detailed explanation of the different operations and equipment involved. In Chapter 4, the most promising energy supply methods for offshore gas installation are presented and discussed.

The case study involved in this research is displayed in Chapter 5, along with its associated data that form the basis of this master's thesis. The results of the process design simulations done to determine the optimal energy supply method with the lowest carbon dioxide emissions, as well as the process optimizations that entailed are presented and critically analyzed in Chapter 6, along with remarks on the limitations of this study. Finally, a conclusion to wrap up the findings of this master's thesis as well as suggestions for complementary future works are included in Chapter 7. The final appendix contains the data and design parameters of the heat exchangers involved in the proposed process optimization setup.

2. Environmental background

2.1. Climate change

Climate change is a disturbance in weather pattern, effecting oceans, land surfaces and ice sheets [4]. One of the main drivers of climate change is the concentration of greenhouse gases in the atmosphere. Even though the most abundant gases in the atmosphere, namely nitrogen (N_2) and oxygen (O_2), do not interact with infrared radiation coming from the sun, other gases that are present in smaller quantities, such as carbon dioxide (CO_2), methane (CH_4), and water vapor, absorb this infrared radiation and re-radiate some of it back to the earth's surface [4]. This phenomenon causes the warming of the earth's surface, resulting in the rising of sea levels, the shrinking of glaciers, and the loss of biodiversity just to name a few. The environmental consequences of climate change pose unprecedented challenges on both the social and economic levels to adapt to the changes and deal with the damages caused by it [4]. Therefore, there exists an urgent need to act against the phenomenon of climate change by limiting the causes led by human activities. In an ideal case, the entire world needs to achieve carbon neutrality in order to theoretically stop human-induced greenhouse gas effects and avoid catastrophic future scenarios.

Carbon neutrality is defined as scoring a balance between the amount of CO_2 emitted and the amount of CO_2 removed from the atmosphere [5]. To achieve this goal, two approaches need to be considered:

1. Minimizing the carbon intensity of all social, economic, and industrial activities.
2. Maximizing carbon removal from the atmosphere through carbon sequestration.

On a more specific level, the European Union aims to become climate-neutral by 2050 with net zero GHG emissions in accordance with the Paris Agreement (November 2016) and the European Green Deal (December 2019), both of which aim to limit human contribution to climate change and control the temperature rise of earth's surface.

The aim of this research paper falls under the scope of minimizing carbon emissions accelerate the reaching of carbon neutrality.

2.2. The role of natural gas in clean energy transition

The shift towards a carbon neutral world is heavily dependent on the ability to switch to a renewable and carbon-neutral energy generation system. Knowing that renewable energy, in many of its forms such as solar and wind is uncontrollable and therefore not reliable as much as fossil fuels, some solutions need to be addressed that can fill the gap between energy supply and demand curves [6]. Natural gas is therefore an attractive candidate that provides security in terms of constant and reliable energy supply with lower greenhouse gas emissions over its entire lifecycle, from extraction to combustion, than its fossil fuel competitors such as oil or coal [6].

The increasing use of natural gas in the current energy mix will benefit carbon-cutting initiatives and will accelerate the process on the short to medium term. Coal-to-gas switching is one of the main areas of concern because of the advantages of using existing power infrastructures without having the need of major capital requirements for infrastructure reworks [7]. Therefore, a simple fuel switch offers a quick and straightforward win in terms of emission reduction. When put into direct comparison with coal, natural gas exhibits an emission reduction of 33% per unit of heat generated and 50% per unit of electricity generated [7]. Consequently, the appreciating use of natural gas has the potential to bring down emissions from the power sector by 10% and total energy related CO₂ emissions by 4%; this already secures 8% of the emission savings needed to reach the sustainable development scenario [7]. Moreover, coal-to-gas switching already has a proven record of reducing global CO₂ emissions as presented by IEA's "The Role of Natural Gas in Today's Energy Transitions" [7], which states that between 2010 and 2018, coal-to-gas switching allowed the mitigation of 536 Mton of CO₂ emitted, as shown in Figure 2.1.

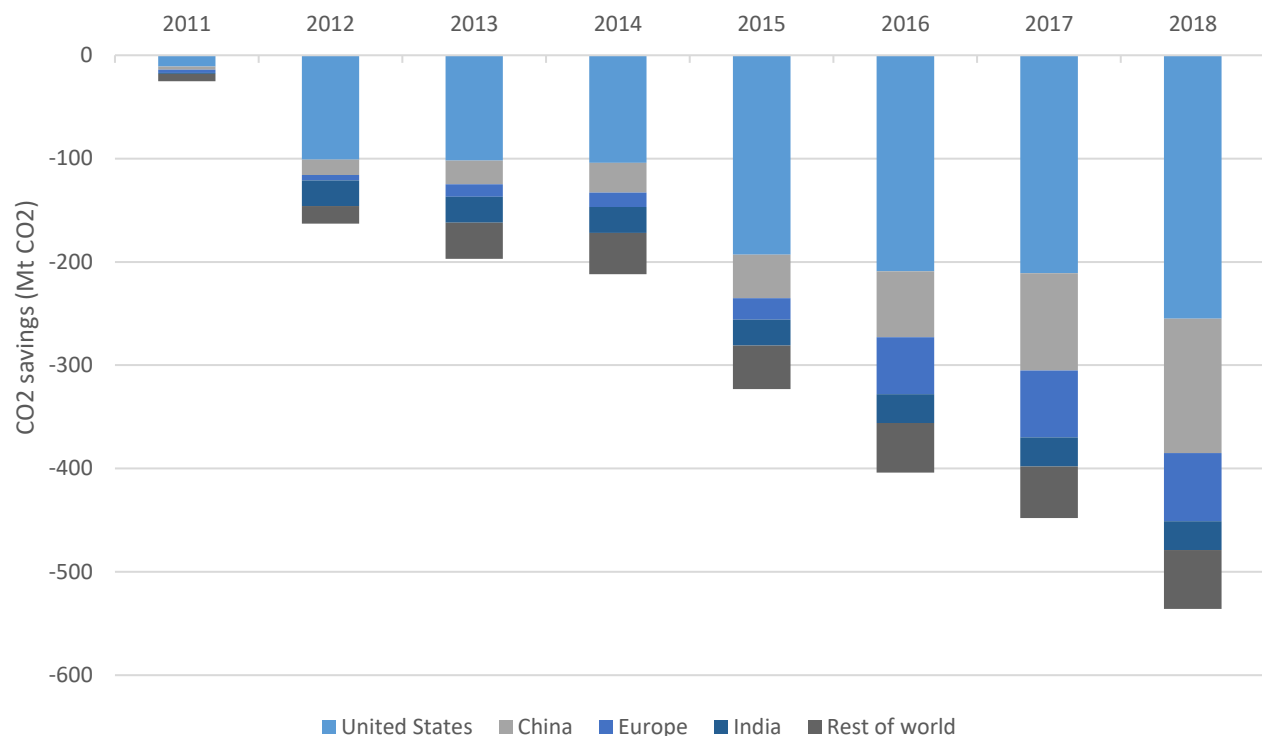

Figure 2.1: CO₂ savings from coal-to-gas switching compared to 2010

In addition to the reduction in carbon dioxide emissions, natural gas is considered to be a more environmentally friendly fuel source than its competitors because it emits a significantly lower amount of other pollutants such as nitrous oxides, sulfur oxides and particulate matter [7].

The advantages of using natural gas as a primary energy supply source have made it into one of the main constituents of today's and the future's energy mix [2]. Oil and gas companies are therefore an integral part of energy transition and will still be major contributors for energy supply worldwide. The question therefore lies in how can oil and gas companies still provide essential primary energy supply while at the same time decreasing the environmental impact of gas production, processing, and transportation.

2.3. The role energy efficiency in clean energy transition

Energy efficiency is defined as achieving the same level of economic or industrial contribution while consuming less energy [7]. Increasing the energy efficiency of the different economic and industrial activities delivers a great number of environmental and social benefits since it contributes to the reduction of both direct and indirect GHG emissions and increases energy accessibility [8]. In chapter 2.2, it was demonstrated that switching to cleaner fuels secures a share of 8% from the total emission savings needed to reach sustainable development goals, though when it comes to energy efficiency the contribution towards the same goal is of 33% as demonstrated in Figure 2.2 [9].

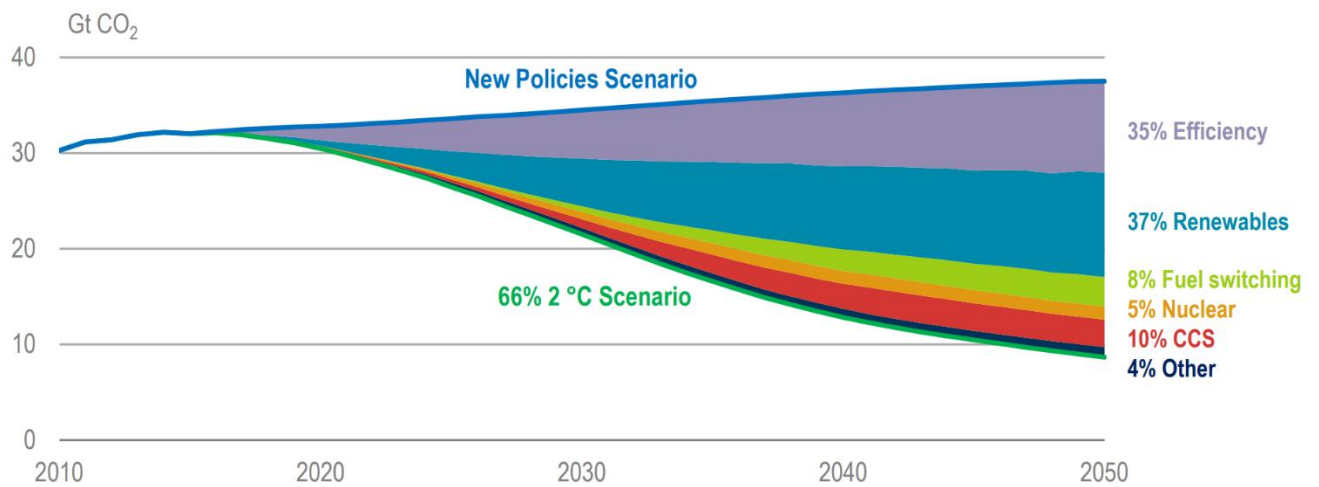

Figure 2.2: CO₂ abatement by technology to reach sustainable development scenario

Achieving higher energy efficiency across the different sectors of the economy tackles climate change in two different ways at the same time. First, the most straightforward result of increasing energy efficiency is the lower consumption of primary energy sources, which leads to lower energy related emissions. Second, a better utilization of the available energy sources reduces costs related to energy supply and can help bring down worldwide energy prices [10]. Improving energy efficiency is possible either by switching to technologies that are more efficient or by implementing operational changes that make better use of the existing technologies through process optimizations [7].

GHG emissions come from different sources of economic and industrial activities, however, energy production and consumption is the largest contributor to global GHG emissions [11]. Oil and gas companies can therefore provide major contribution in cutting global CO₂ emissions by increasing the energy efficiency of the production, processing, and transportation of oil and natural gas and limit the environmental impact of their industrial activities. This master's thesis tackles this challenge by investigating energy optimization for oil and gas processing offshore.

3. Offshore oil and gas platforms

3.1. Description of the platform and system boundaries

An offshore hydrocarbon production platform is a facility whose aim is to extract hydrocarbons from reservoirs present under the seabed. Offshore production accounts for 30% of global oil production and 27% of global gas production [12]. Often times, offshore platforms are erected at a far distance from the shore in remote locations, which is why most of these platforms are designed to be self-sufficient when it comes to energy needs [13]. The utility plant, commonly in the form of a conventional gas turbine, generates power and heat for all the different system blocks of the platform, such as the living quarter of the crew, the drilling activities, and the oil and gas processing plant. The scope of this research paper focuses solely on the energy requirements of the oil and gas processing plant. Figure 3.1 shows the different blocks making up the offshore installation along with their utility inlet and outlets, and highlights the systems boundaries of the occurring study.

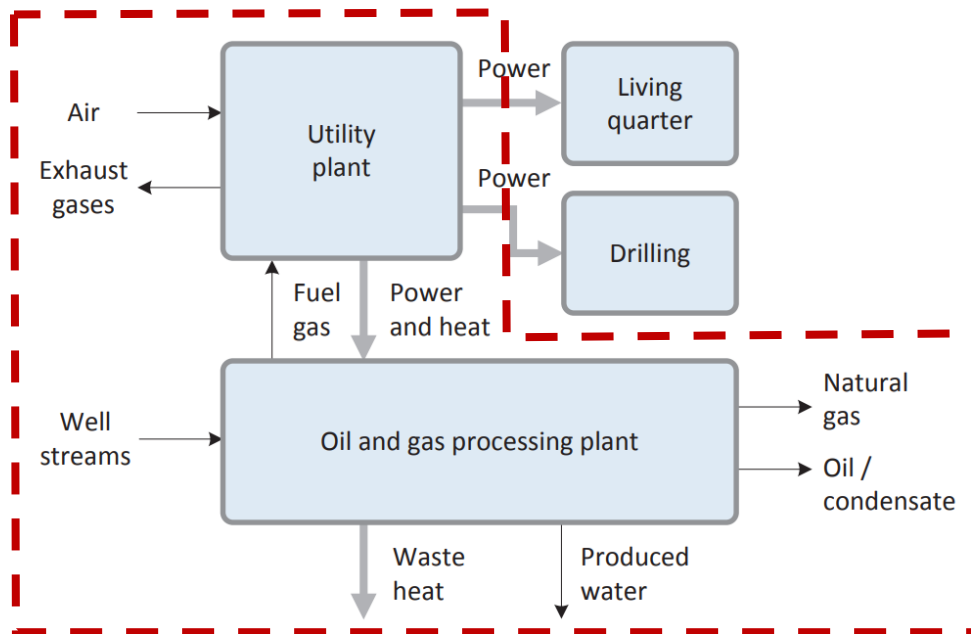

Figure 3.1: Schematic of the different blocks of an offshore gas installation [14]

3.2. Natural gas processing

Processing of natural gas following extraction is necessary to meet certain market and pipeline specifications. Natural gas can be produced from oil wells, gas wells, and condensate wells. Associated gas is the term used to label natural gas coming from oil wells, whereas if it is produced from gas or condensate reservoirs then it is termed non associated gas [14]. In oil wells, the gas either exists freely in the formation or is dissolved in the crude oil due to the high pressure in the reservoir. Condensate wells produce free gas as well as liquid hydrocarbon condensate, and gas wells produce raw natural gas. Even though natural gas is primarily composed of methane, it often exists in mixtures with other heavier hydrocarbons such as ethane, propane, butanes and even pentane. Other impurities are also commonly present such as nitrogen, oxygen, CO₂, H₂S, and water [15].

After extraction, natural gas is not directly transported to onshore processing facilities because if a multiphase flow occurs, pressure drop across the pipeline will increase and affect the material streams' transport mechanism. Therefore, it is preferred to have single-phase transport through pipeline. Primary treatment of the produced gas near the wellhead is necessary to separate the phases present in the produced streams to export rich gas and stabilized oil or condensate, and discharge the produced water [16].

After primary separation at or near the wellhead, natural gas is sent to an onshore gas processing plant where it is further treated to meet market specifications. If the produced gas has a high quality directly after primary separation, then it is directly exported to the final consumers via pipeline.

Primary natural gas processing can be segmented into three different tasks: Water removal, impurities removal, and heavy hydrocarbon removal. Figure 3.2 illustrates a typical gas treatment plant with the different processes involved. Each of the gas treatment processes is thoroughly explained in the following paragraphs.

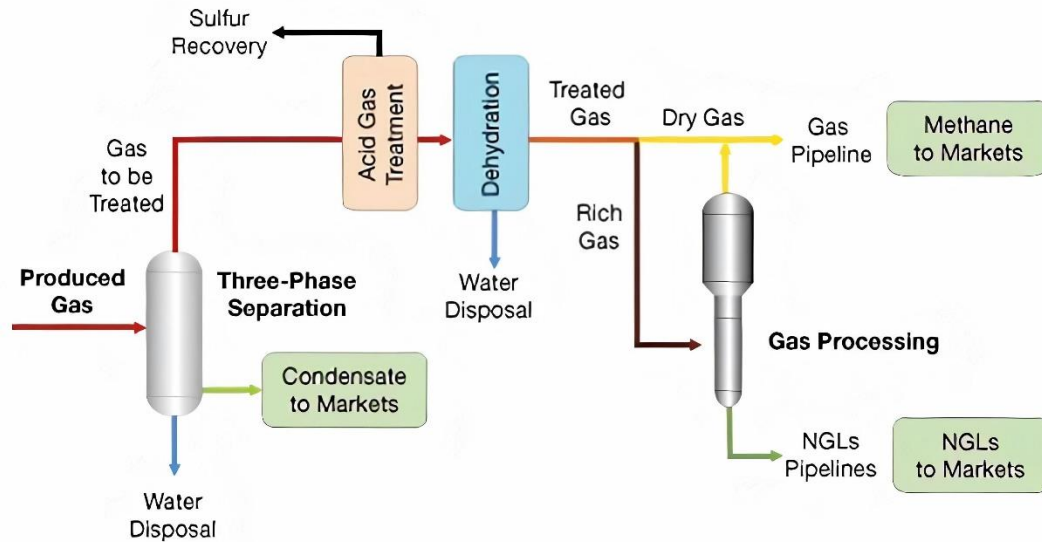

Figure 3.2: Gas treatment plant schematic [17]

3.2.1. Oil and condensate removal

Raw natural gases have different compositions depending on the initial conditions in which they exist. Therefore, the separation process and the equipment needed to achieve the desired grade of separation vary from one hydrocarbon field to the other [14]. When natural gas is dissolved in the produced oil, additional heating is needed to boil off and separate the light hydrocarbons from the heavy hydrocarbons into two different phases. If the wellhead stream produces two different phases, a conventional separator is used where gravitational segregation causes the light gases to rise into the gas treatment and compression train, and the heavy liquids to move into the oil stabilization train. Further treatment of the natural gas is often needed to achieve the desired “pipeline quality” specifications, which are set by the pipeline operators to ensure a safe and efficient mode of transportation [16]. Specifications for rich gas transport are mainly focused on the cricondenbar pressure of the rich gas produced. Often, the gas stream exiting the first stage separator of the produced well stream contains a fair amount of medium and heavy hydrocarbons, resulting in a bigger phase envelope and a high cricondenbar pressure compared to the pipeline specifications. A manipulation of the phase envelope of the rich gas by means of NGL removal reduces the phase envelope and consequently also the

cricondenbar pressure [18]. NGL removal can be achieved by applying a series of compression, cooling and separation steps to condensate and remove the desired amount of NGL, achieving the target cricondenbar pressure.

NGL that have been removed from the rich gas stream is sent to the oil stabilization train. The produced oil or condensate is stabilized at atmospheric pressure to ensure that there are no more volatile compounds dissolved in the mixture and is exported either by pipeline or by oil vessels with storage tanks at around 1 atm. A common practice in the oil and gas industry consists of heating up the oil to stabilize it at a higher temperature for final export [18].

3.2.2. Water removal

The extraction of natural gas is usually accompanied by the production of reservoir water. Much like gas, the produced water can either be obtained as free water or in solution with the natural gas produced. The presence of water in combination with natural gas can lead to several technical problems such as the formation of methane hydrates that can plug valves and even pipelines, the formation of corrosive materials if the natural gas contains sulfur contaminants, and the erosion of pipelines due to water condensation [19]. It is therefore necessary to control the water composition of the natural gas to avoid technical complications.

When free water is produced, a three-phase separator is applied at the inlet to obtain a gas stream, an oil stream, and a water stream. If the temperature of the well stream is relatively low, water and oil are separated from gas at the inlet, then free water is removed from oil in a second stage separation operating at a higher temperature. Oil/water separation at higher temperatures is more advantageous due to the high viscosity of the oil [20].

When water is present in solution with the natural gas, a more complex treatment is required for the dehydration of the rich gas involving either adsorption or absorption processes, with absorption being the most widely used method [21]. Absorption occurs when a dehydrating agent with high chemical affinity to water is introduced to the mixture. A frequently used sorbent for dehydration is triethyleneglycol (TEG) in liquid form [19]. When put into contact with the gas mixture, TEG absorbs the water vapor, which increases

its density and forces it to settle on the bottom of the contactor where it is removed. The dried gas exits the contactor and the liquid mixture is sent to a TEG regeneration unit where the absorbed water is boiled out and TEG can be reused [19].

3.2.3. Sour gas removal

Sour gas, or acid gas, is a gas that contains relatively high amounts of sulfur contaminants (more than 4 ppmv H₂S [22]). The presence of sulfur in the production stream imposes various technical and safety hazards. From the technical point of view, sulfur contaminants can be very corrosive, especially in the presence of water, and can easily damage process equipment and piping systems. From the health and safety perspective, sulfur compounds can be very dangerous, and even lethal to breathe.

Sour gas removal involves purifying the extracted natural gas from sulfur contaminants and from CO₂ if present in high levels to produce sweet gas. The process involves putting the gas stream in contact with a lean solvent, usually amine solutions, in an absorber column [23]. Similar to gas dehydration, the amine solution absorbs the sulfur contaminants and CO₂ from the natural gas and is recuperated from the bottom of the column. Sweet effluent gas exits the contactor and the rich solvent then enters an amine regeneration unit where acid gases are released and the amine solution is purified for reuse [24].

3.3. Process components

3.3.1. Separators

A separator is a vessel that is used to separate the different phases from the incoming production stream. Different types and classifications of separators are presented by depending on their function [25]. Horizontal separators have the advantage of a larger area of transfer from the liquid phase to the gas phase; however, vertical separators are advantageous in offshore settings because they occupy a lower surface area compared to horizontal separators. To meet hydrocarbon export pipeline and market specifications, separators are often designed in stages. The first stage separator is usually used for phase separation of the inlet production stream. Further stages of separation, both from the oil

stabilization and the gas treatment sides, are used for additional treatment of the separated material streams in order to meet process requirements [26]. From the gas compression and treatment side, separators are used to remove fluid mists in scrubbers and to eliminate other unwanted substances such as Hydrogen Sulfide (H₂S) and Carbon Dioxide (CO₂) if they have high concentrations in the produced flow. From the liquid side, separators are applied to remove water from the oil often at higher temperatures to enhance the separation process due to the high viscosity of the oil.

3.3.2. Compressors

Compressors are pressure changers used to increase the pressure of an incoming gas stream [27]. Because gas is a compressible fluid, the volume of the gas is reduced upon discharge from the compressor. The compressor consumes energy in the form of electric power and transfers it to the gas, which translates into a higher-pressure and higher-temperature flow [27]. In oil and gas applications, compressors are used to pressurize natural gas streams, allowing its transportation from the production platform onto either a petroleum refinery or directly to final consumers. In an ideal case, isothermal compression would require the lowest possible amount of power to bring the gas up to the desired pressure. However, since this is not actually feasible in real-life applications, the compression of natural gas is done over several stages with similar compression ratios [27]. After each compression stage, the gas stream is cooled down before entering the next stage, mimicking the isothermal compression process to a certain extent and therefore decreasing the total amount of power needed to reach the desired end pressure. The following formula correlates the inlet and outlet temperatures and pressures to the power required by the compressor:

$$P = \frac{2.31 \times \frac{n}{n-1} \times \frac{T_{out} - T_{in}}{M} \times \dot{m}}{\eta}$$

$$pV^n = C$$

P : power kW

p : pressure

T_{in} : inlet suction temperature (K)

M : Molar weight of gas (g/mol)

\dot{m} : inlet mass flow rate (t/h)

n : Gas polytropic coefficient

This formula is valid for centrifugal compressors; in the case of an isentropic compressor, the polytropic coefficient is replaced by an isentropic coefficient k .

3.3.3. Pumps:

Similar to compressors, pumps are pressure changers used to increase the pressure of an incoming liquid stream [28]. It also consumes electrical energy and converts it into hydraulic energy. In Oil and Gas applications, pumps are used to pressurize liquid hydrocarbon products for exports from the platform, and in seawater cooling circulation systems. Centrifugal pumps are the most frequently used pumps in the oil and gas industry. In this type of pumps, fluid is drawn into the inlet of the pump by centrifugal force from the rotation of an impeller, and forced through the discharge [28]. The following formula is used to determine the power required by the pump to bring the fluid up to the desired pressure to meet process specifications:

$$P = \frac{\dot{V} \times H \times \rho}{1000 \times 367 \times \eta}$$

$$H = \frac{p_2 - p_1}{\rho \times g}$$

p_1 : Suction pressure

p_2 : Discharge pressure

ρ : Density

\dot{V} : Volumetric flow rate m³/hr.

H : Total head m

η : Efficiency

g : Gravitational acceleration

3.3.4. Heat exchangers:

Heat exchangers are devices used to transfer heat between two or more process fluids [29]. The uses and applications of these devices are numerous and vary from one use case to another. A detailed and thorough design of a heat exchanger is essential to have the optimal setup for a selected function. The physical and chemical properties of the fluids involved in the process, the characteristics of the materials used in the construction of such equipment, and the amount of heat that needs to be dealt with are all factors to be taken into consideration when designing a heat exchanger [30].

In order to design a heat exchanger for a specific application, key design characteristics have to be taken into account, namely flow configuration, construction method, and heat transfer mechanism [31].

In terms of flow configuration, there exist four main arrangements. Cocurrent flow heat exchangers are devices where the process fluids move parallel to each other and in the same direction. Countercurrent flow heat exchangers also have parallel fluid streams; however, they flow in opposite directions. In crossflow heat exchangers, fluids streams are perpendicular to each other. Finally, hybrid flow heat exchangers include a combination of the aforementioned flow configurations [32]. Typically, countercurrent heat exchangers provide the highest heat transfer efficiency compared to other flow configurations.

When it comes to the construction method, the most widely used type of heat exchanger is the shell and tube heat exchanger. It is classified as an indirect heat exchanger where the process fluids are not put into direct contact with each other [33]. A shell and tube heat exchanger consists of either a single tube or multiple tubes enclosed inside a sealed pressure vessel (shell). The concept behind it is that one fluid passes through the tubes and the other flows around it in the shell [31]. The total heat transferred between the shell and tube sides, or the heat exchanger duty is determined using the following formula:

$$\dot{Q} = UA\Delta T_{LM}F_t$$

\dot{Q} : Total heat load

U : Overall heat transfer coefficient

A : Heat transfer area

ΔT_{LM} : Log mean temperature difference (LMTD)

F_t : LMTD correction factor

Regarding the oil and gas industry, heat exchangers have numerous applications both upstream and downstream, and can serve to accomplish both cooling and heating duties. Some examples regarding common applications of heat exchangers in the oil and gas industry include oil cooling, preheating, steam generation and vapor recovery systems [31].

4. Power and heat supply offshore

In order to run the process equipment and achieve the desired goal of the hydrocarbon treatment processes, energy needs to be supplied to the oil and gas processing block of the installation. Currently there exist a fair number of technologies already employed in energy supply offshore, as well as some proposed technologies in literature that provide interesting solutions. In this chapter the most interesting concepts for heat and power supply offshore are presented.

4.1. Gas turbines

4.1.1. General definitions

The use of gas turbines is advantageous in applications where a large amount of power is needed but there are constraints in terms of physical size or area available, which is the case of offshore gas platforms. When considering this type of setup, the power and heat requirements of the offshore gas platform are met through local energy generation. A gas turbine is installed on the offshore platform to provide energy for the different processing blocks of the facility [34]. In a gas turbine, atmospheric air is pressurized by a compressor at the inlet. Pressurized atmospheric air is then mixed with fuel, namely natural gas or diesel fuel, to add energy to the material flow. In an offshore gas platform, the fuel gas used to feed the gas turbine is directly provided from the produced natural gas. The mixture is then ignited and the combustion results in a high-temperature, high-pressure flow. The inlet material stream mixture enters a turbine where it expands, generating shaft work, which is then converted into electricity by an electric generator [34]; Figure 4.1 shows a simplified schematic of a gas turbine.

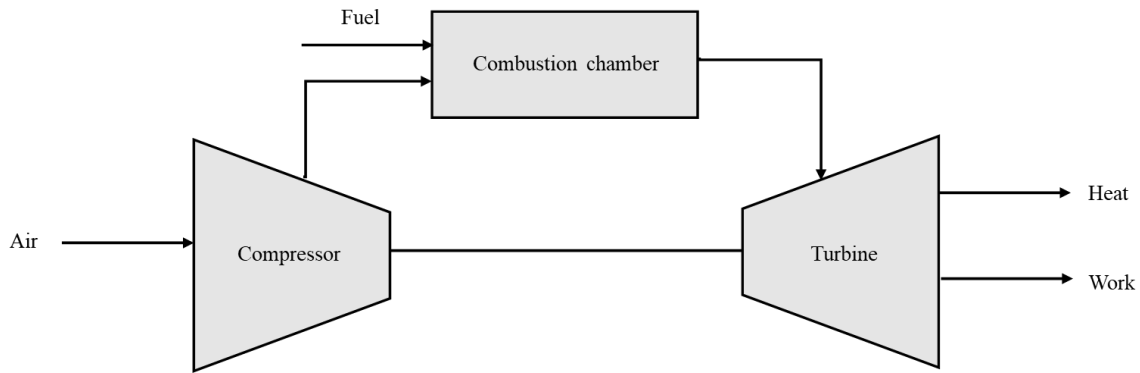

Figure 4.1: Simplified schematic of a gas turbine

However, not all of the energy available is converted into shaft work; around half of the produced power is consumed by the compressor at the inlet of the gas turbine, and the unconvered energy is released in the flue gases either in the form of high temperature or high velocity stream [34]. The turbine inlet temperature (TIT) is an important parameter that determines the cycle efficiency and the specific power (net power output divided by air flow rate $\text{kJ}_{\text{power}}/\text{kg}_{\text{air}}$) of the system as shown in; the higher the TIT, the higher the efficiency and specific power as shown in Figure 4.2. Combustion in a gas turbine usually takes place with a high excess air ratio, typically in the range between 2.5 and 3.0 [35].

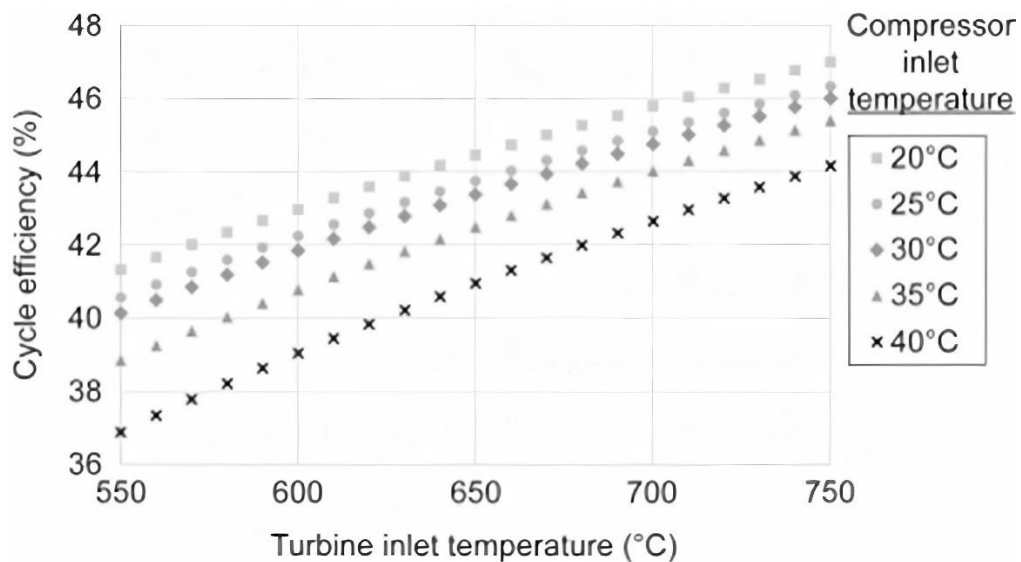

Figure 4.2: Effect of TIT on gas turbine efficiency [36]

A recuperated gas turbine is an optimized simple cycle gas turbine setup which employs internal heat recovery from the exhaust gases exiting the turbine at high temperatures. A fraction of the exhaust gases are introduced into a heat exchanger from the hot utility fluid side to pre heat the air entering the combustion chamber which enters from the cold utility fluid side [37]. This setup allows for a significant saving in terms of fuel consumption since the air requires a lower amount of heat to reach the same temperature in comparison with a simple cycle gas turbine model. A simplified schematic of the the recuperated gas turbine cycle is show in Figure 4.3.

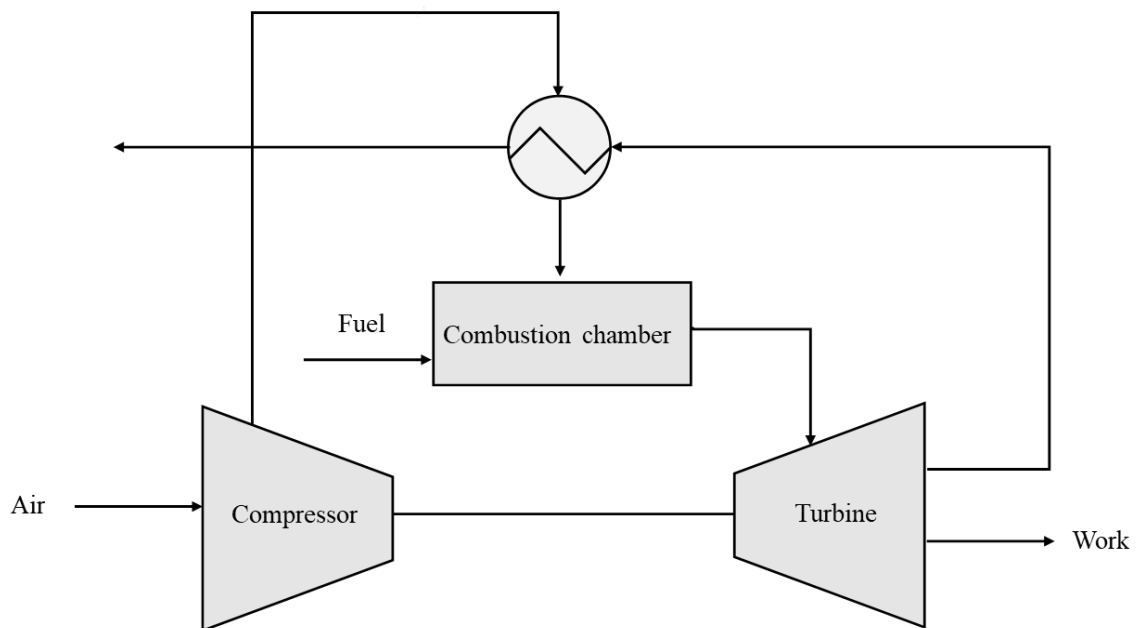
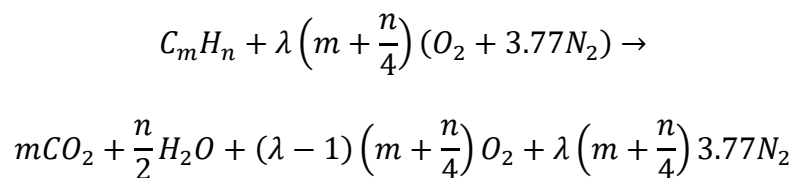

Figure 4.3: Simplified schematic of a recuperated gas turbine

4.1.2. Combustion of fuel in a gas turbine

As stated before, the combustion of fuel in gas turbines usually takes place with high excess air ratio. The chemical reaction for complete combustion of fuel with excess air is as follows [35]:



From this equation it is deductable that the higher the molecular weight of the fuel used in the combustion process, the higher the CO₂ fraction in the combustion products for the same air excess. Also, for the same type of fuel used, the lower the air excess, the higher the fraction of CO₂ in the combustion products. This technically justifies the lower emissions that occur from the combustion of natural gas when compared to the combustion heavier fossil fuels such as coal as presented in Chapter 2.2.

4.1.3. Gas turbine cooling

When dealing with very high temperatures, gas turbines require blade cooling to prevent damaging the material from which the vanes and the blades are made. In most cases, this operation is done by using air coming from the compressor at the inlet of the gas turbine and sending it through the turbine blades to cool them, after which, it mixes with the hot gases flowing inside the turbine [35]. Even though turbine cooling is absolutely necessary when the turbine inlet temperature is above the maximum allowable for the materials used in its construction, mixing both cold and hot fluids in the turbine causes some performance losses of the system. This is mainly due to the lowering of the overall temperature of the expanding gas, reducing the momentum of the hot gas, and disturbing the flow profile around the turbine blades. Turbine cooling can be performed using different methods, out of which, the most important ones are convection cooling, film cooling, and water or steam cooling [35].

4.2. Heat recovery

Industrial waste heat is defined as the energy generated in industrial processes and that is not put into use and simply released into the environment [38]. To put it into numbers, it is estimated that around 53% of global energy use eventually ends up as waste heat [39], which highlights the vast range for the potential improvements in terms of increasing the thermal energy efficiency of processes. Waste heat is classified into high, medium or low temperature range. The different temperature ranges used in the classification of heat loss can be found in Table 4.1 [38] [39]. For each temperature range, different technologies exist to exploit the unused heat in an efficient manner depending on the amount of heat available. Considering the oil and gas industry, sources of waste heat include heat loss

transferred from equipment and processes and heat released from combustion activities and in flue and exhaust gases [41].

Table 4.1: Temperature ranges of waste heat and their share from the total

	Low temperature WHR	Medium temperature WHR	High temperature WHR
Temperature (°C)	< 120	120-450	>450
Share of total waste heat in industry	64.6%	30.2%	5.2%

The amount of waste heat available for recuperation is a function of the heat-carrying substance's thermophysical properties and can therefore be determined using the following equation:

$$Q = \dot{V} \times \rho \times C_p \times \Delta T$$

Q : Heat content

\dot{V} : Volumetric flow rate of the substance

ρ : Density of the substance

C_p : Specific heat of the substance

ΔT : Difference between highest and lowest temperatures

When it comes to the combustion of fuel for heat or power generation, there exist three main classifications of the thermodynamic cycles involved based on the sequence of energy use. In topping cycles, the primary function of the fuel combustion is to produce power and then thermal energy as a byproduct, which can be exploited to provide heat for some process sections. In bottoming cycles, the primary function of the combustion of the fuel is to supply thermal energy for a specific process, and then the dissipated heat is recuperated to generate additional power [42]. Topping and bottoming cycles serve the function of providing separate heat and power production to satisfy the different energy needs for a given activity; these setups are termed combined heat and power generation or simply

cogeneration. The last classification consists of a combination of both a topping and a bottoming that can further increase the net power plant efficiency if in a specific application the amount of recuperable heat is higher than the process heat requirements. In this case, a topping cycle is applied to produce power, which releases heat that is recovered in a waste heat recovery unit and introduced into a bottoming cycle that uses a share of this heat to produce additional electricity and provide supplementary power for the system; this setup is termed combined cycle power generation.

In applications where a gas turbine is the chosen method for energy supply in an offshore oil and gas platform, making use of waste heat can be performed either through cogeneration or by applying combined cycles that work in conjunction with the same heat source [43]. Thus, the wasted heat can be used for multiple purposes including electricity generation and heating up other processes or equipment.

4.2.1. Cogeneration

Theoretically speaking, cogeneration can achieve up to 92% in thermal energy efficiency if all the wasted heat is put into practical use [44]. In offshore oil and gas installations, fuel is consumed by the gas turbine to generate electric power, and then heat as a byproduct in the exhaust gases. Therefore, the Brayton cycle, upon which the gas turbine is based upon, acts as a topping cycle for combined heat and power generation. A simplified schematic of a topping cycle is presented in Figure 4.4.

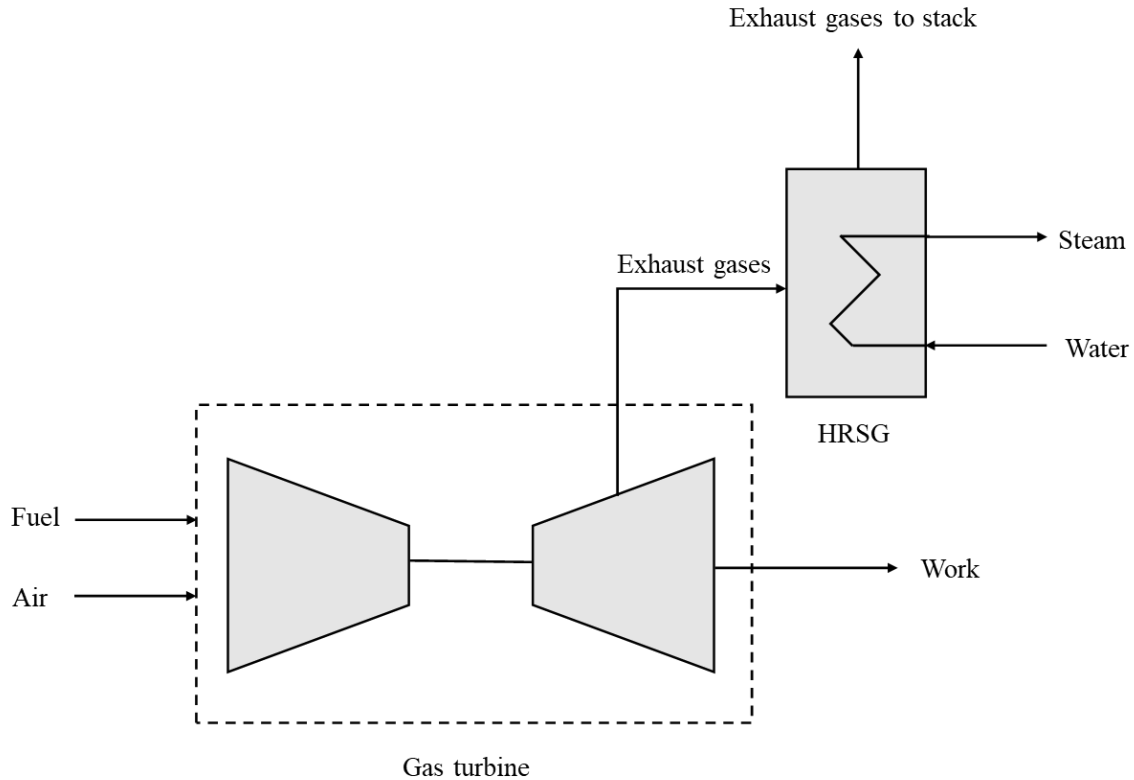

Figure 4.4: Schematic of a gas turbine topping cycle couple with a WHRU

Following the principles of a topping cycle, thermal energy that is generated as a byproduct is recuperated and transferred into another medium in what is called a waste heat recovery unit (WHRU). The most widely used heat-carrying medium is water, which is circulated through a heat exchanger that is referred to as heat recovery boiler or heat recovery steam generator (HRSG). In the HRSG, thermal energy contained in the turbine exhaust gases is transferred to a pressurized cold water stream to generate hot steam. The generated steam is circulated through a heating circuit to supply heat for the selected process sections. In a cogeneration system, process heat requirements determine the pressure, temperature, and the amount of steam to be provided by the HRSG for the heating circuit. The advantage of such implementation is the potential of either reducing or eliminating the need for additional heaters, and consequently reduce the overall energy requirements of the system, resulting in lower overall emissions [45].

4.2.2. Combined cycles

As stated previously in this chapter, a combined cycle consists of a series of heat engines working in tandem with the same heat source. A combined cycle setup can yield up to 60% in net plant thermal efficiency [46]. The number is lower when compared to the maximum theoretical thermal efficiency in cogeneration applications because the secondary conversion from heat to power will further suffer from heat losses. In an offshore setting, a combined cycle is formed by a gas turbine, acting as a topping cycle, followed by a rankine bottoming cycle. A typical layout of a combined cycle is presented in Figure 4.5.

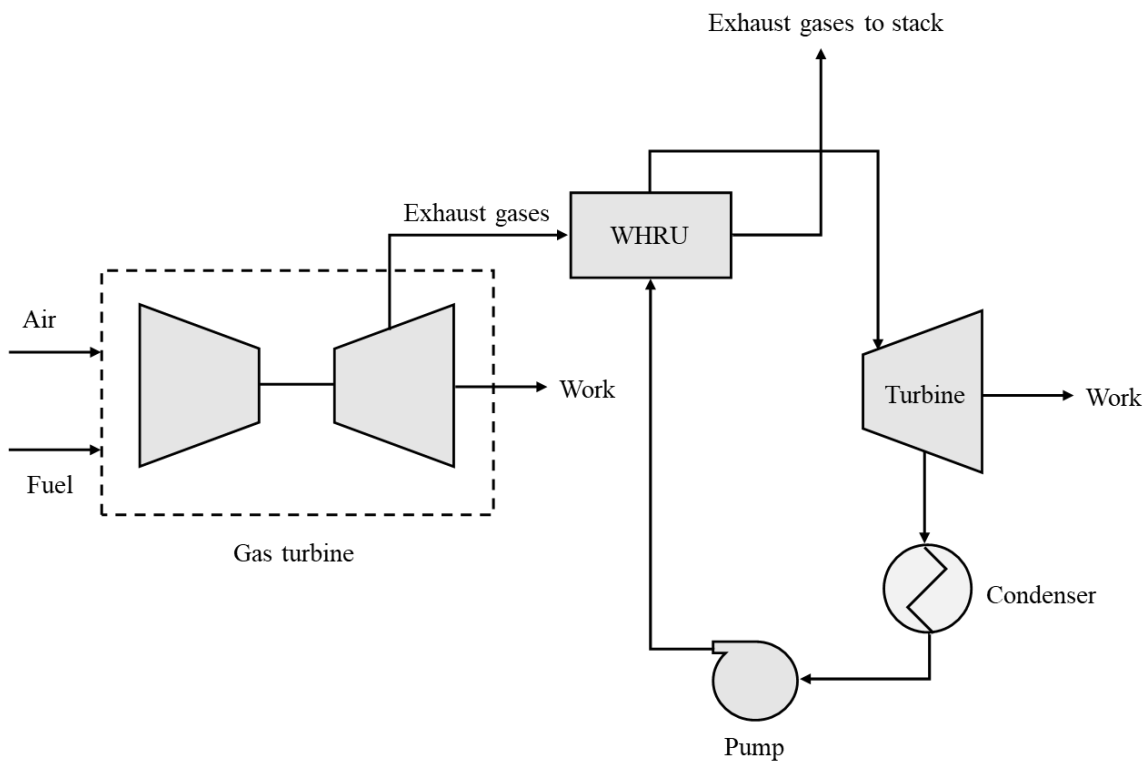

Figure 4.5: Simplified schematic of a combined power cycle

Since there is a temperature range for waste heat sources, and that the bottoming cycle's configuration is dependant of the amount of heat available to work with, rankine cycles include subdivisions of different setups depending of the type of fluid involved in the closed system and the differences in configurations that contribute to an increase in operational efficiency. Steam bottoming cycles and organic rankine cycles are the most

investigated bottoming cycles for offshore applications. A detailed overview of these two technologies is presented in the following subsections.

4.2.2.1. Steam bottoming cycles

A steam bottoming cycle is a Rankine cycle that uses water/steam as a working fluid. The circulated water exploits the heat recuperated by the WHRU to generate steam and move a turbine to generate electricity. Steam bottoming cycles require constant high temperature heat (above 500°C) to operate and are usually very big in size, which makes their implementation challenging in settings where occupational area is limited [42].

When the HRSG is part of a combined cycle system, the steam conditions are determined by the steam turbine requirements and by efficiency optimization parameters of the whole plant. This renders the HRSG to be technically more complex than in the case of cogeneration due to the involvement of more sensitive equipment with more specific operating parameters than a simple heating circuit. The conventional HRSG is the drum-type shown in Figure 4.6, consisting of three stages of heat exchange with three different modules [47]. The first module is referred to as the economizer, where low grade heat is added to the feedwater returning from the heating circuit. The hot water is then introduced into the second module called the evaporator that raises the water's temperature up to its boiling point. The evaporator is coupled with a steam drum at the top, where steam is separated from the water. The water is redirected into the evaporator and the steam is driven into the last module of the HRSG called the superheater. In the superheater, the incoming steam is further heated and dried before being driven into the steam turbine [47]. The drum-type HRSG has proven to be efficient in onshore applications, however in an offshore setting, size limitations pose a handicap for the implementation of such a setup. The once through steam generator (OTSG) offers an advantage over the drum-type since the conversion from water to steam happens in the evaporator, eliminating the need for the steam drum which takes up big chunks of space. In offshore applications, where area is very limited, the compactness of the OTSG in comparison to the drum-type HRSG renders the implementation of steam bottoming cycles more feasible, making it an attractive option for cogeneration application in these settings.

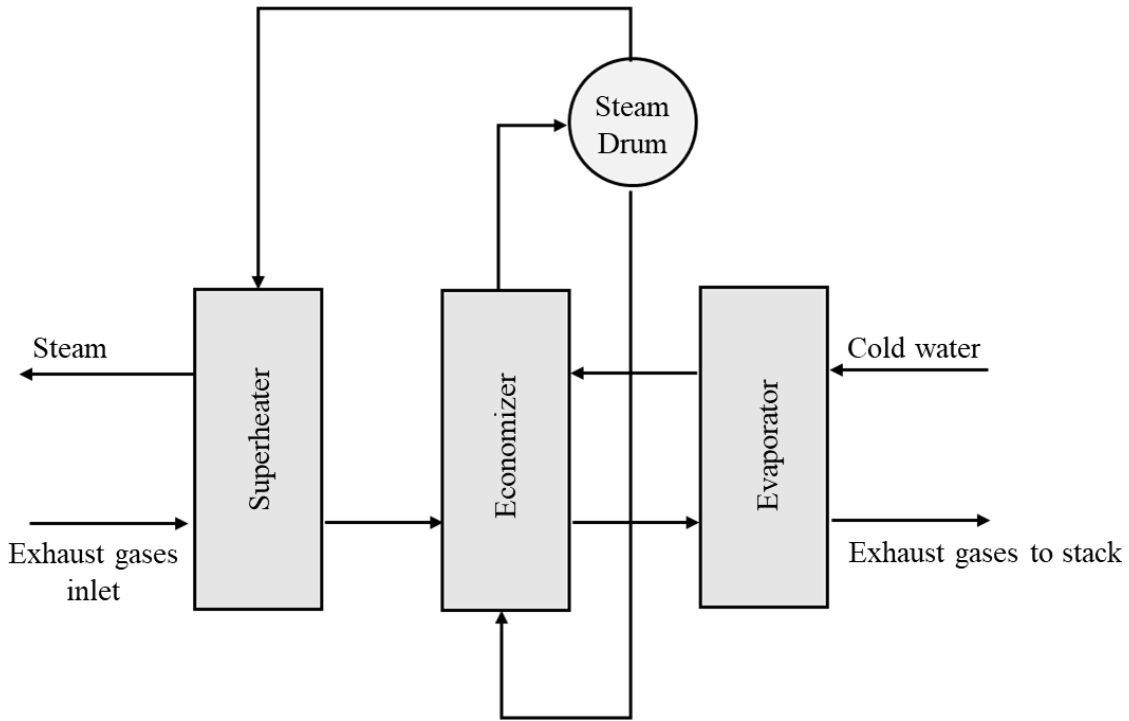

Figure 4.6: Drum-type HRSG

4.2.2.2. Organic rankine bottoming cycles

An organic rankine cycle is very similar to the steam bottoming cycle in terms of configuration, except that the working fluid is an organic compound that has a lower boiling temperature than water. Some examples of organic working fluids used in ORC applications include, but are not limited to, R-123, R-134a, ammonia, and benzene [48].

The advantages of this setup mainly lie in the fact that it is a better tool for recuperating lower temperature heat (between 80°C and 350°C [49]) to generate electricity in cases where a steam cycle would be inefficient [50]. ORCs are also more flexible than the conventional steam cycles thanks to the diverse options of organic working fluids, which means that thermal efficiency can be maximized for each individual case when the proper fluid is selected to match the amount of heat available. Moreover, operation and maintenance costs of ORCs are lower compared to SCs because they operate at lower temperatures and pressures, and are subject to lower mechanical stresses, which guarantees a longer lifetime for the setup.

Despite the advantages that ORCs exhibit, some drawbacks have to be mentioned. Because ORCs exploit low temperature heat sources, the overall efficiency and the plant size are limited [48]. Also, the use of organic fluids might impose some health and safety hazards due to their high flammability and their questionable environmental performance as some of these working fluids are capable of damaging the ozone layer [48].

4.3. Electrification

Offshore platform electrification allows that all the energy requirements of the installation are provided from electricity produced in onshore power plants and transmitted through underwater cables. This concept lately received major social and political support due to its claimed environmental benefits [51].

Some things though have to be taken into consideration when discussing the option of full electrification, such as the source through which electricity is being provided for the offshore platform. Hence, electricity can be supplied either from traditional power plants that run on fossil fuels such as coal, oil or gas, or from other renewable sources such as wind, solar or hydro power, or even from nuclear power plants. Therefore, since electrification is often seen as the ultimate solution to decarbonize the oil and gas industry, carbon emissions from the different power generation sources have to be taken into account to better assess the true advantages of switching from local energy generation to electricity import from shore [51]. Also, the fact that renewable electricity production, which is the main contributor of bringing down the CO₂ emission factor for electricity generation, is already operating at full capacity. Therefore, to account for the additional load that needs to be allocated on the grid to power the offshore gas installation, it is most probable that this will require the startup of either a coal, oil, or gas power plant to accommodate for the increase in electricity demand. Consequently, the problem that this alternative is attempting to tackle is not solved and can even perhaps have negative consequences in terms of CO₂ emissions. Therefore, importing power from shore is a very attractive approach from a theoretical point of view, but in real life applications, this could imply that this alternative is actually the least attractive and the most polluting [51].

Some alternative approaches are studied in literature where dedicated solar or wind farms are built exclusively to meet the platform's energy demands, which in theory will greatly impact the carbon emission factor of the source of electricity and will contribute to its decarbonization. However, the huge capital expenditure for the realization of such projects undermine the emission-cutting and environmental advantages of the aforementioned approach [51].

In either case, whether power was supplied from the onshore grid or from a dedicated renewable power source, electricity supply will suffer from transmission losses from the cables through which electricity is driven. The further the power source is from the offshore platform, the more transmission losses will occur [51]. Consequently, full platform electrification is more advantageous when there is a developed network of transmission cables and where electricity production is abundant enough in a proximity radius of the offshore platform. This minimizes transmission losses from the source, resulting in a more energy efficient setup. To minimize transmission losses, AC current is converted into DC current before being sent in the cables, and then back to AC current by transformers mounted on the offshore installation. [52]

4.4. Performance indicators

CO₂ emissions are related to certain parameters that correspond to different energy supply methods. In the following subsections, an overview of the key performance indicators that have a direct impact on the amount of CO₂ emissions are presented.

4.4.1. Source to Site ratio

According to ENERGY STAR, source to site ratio is a parameter used to evaluate the energy performance of commercial facilities [53]. On the one hand, site energy is defined as the amount of heat and electricity directly consumed by a commercial facility. On the other hand, source energy is the amount of energy provided by the source, taking into account conversion, transmission, and distribution losses. The lower the source to site ratio, the more energy efficient is the system. In an ideal case, source to site ratio would be equal to 1 when zero losses occur due to inefficiencies and conversion [53].

4.4.2. Net plant efficiency

The efficiency of a power plant, or net plant efficiency, relates the net power output of the plant to the heat value of the fuel. The higher the efficiency, the more of the fuel's heat value is utilized and converted into electricity or heat [54]. The unutilized energy contained in the fuel is either lost during conversion or released in exhaust gases. The greater the efficiency, the lower the amount of CO₂ emitted per unit of work done. The net plant efficiency can be computed using the following formula:

$$\eta_{net,plant} = \frac{\dot{W}_{net,plant}}{\dot{m}_f \times LHV_f}$$

$\eta_{net,plant}$: Net plant efficiency

$\dot{W}_{net,plant}$: Net plant power output

\dot{m}_f : Mass flow rate of the fuel

LHV_f : Lower heating value of the fuel

The net plant power output includes power generated and power consumed by the different blocks of the utility plant. It is therefore defined as:

$$\dot{W}_{net,plant} = \sum \dot{W}_{output} - \sum \dot{W}_{requirement}$$

\dot{W}_{output} : gross power output at generator(s) terminal

$\dot{W}_{requirement}$: utility plant power requirements

Net plant power out can be computed for a single gas turbine or for a more complex system involving waste heat recovery and combined heat and power generation systems.

The typical range for gas turbine efficiency is between 35-40% for large gas turbines used in power plants, 37-42% for medium sized gas turbines (10-50 MW), and 25-32% for small gas turbines designed for propulsion purposes (1-10 MW) [35].

In this research paper, General Electric's LM2500+G4 is the chosen gas turbine in the simulation with a gross efficiency of 39.3%.

4.4.3. Carbon emission factor

A Carbon dioxide emission factor is defined as the total amount of CO₂ emitted per unit of activity done. In the case of energy generation, whether it is power or heat, the CO₂ emission factor is the amount of carbon dioxide released into the atmosphere per unit of power or heat generated (kg CO_{2 eq}/kWh) [45]. The emission factor considers the amount of CO₂ emitted during the entire lifecycle of an energy source, including its production, processing, transportation, and combustion. Previous research has been conducted to determine the CO₂ emission factor of different energy sources, both fossil and renewable. One can only observe that the computed numbers vary drastically from one source to the other. This is because there are no specified criteria on which source of CO₂ emissions to take into consideration when computing the total lifecycle emissions of an energy source. CO₂ emission factor can also be determined on a national, regional, and global scale. It is calculated as the ratio of CO₂ emissions from public electricity and heat production and gross electricity production from all the different energy sources [55]. Data shows that CO₂ emission factors differ from one energy source to the other (for example: 0.393 kg CO_{2 eq}/kWh for anthracite, 0.237 kg CO_{2 eq}/kWh for natural gas 0.007 kg CO_{2 eq}/kWh for wind power [56]) and from one geographical location to the other (for example in 2017, the CO₂ emission factor for electricity generation was 0.1476 kg CO_{2 eq}/kWh in Denmark, 0.419 kg CO_{2 eq}/kWh in Germany, and 0.0093 kg CO_{2 eq}/kWh in Sweden [57]). Lower CO₂ emission factors imply that in these geographical areas, renewable energy makes up a bigger share of the energy mix. Nevertheless, data shows that the share of primary energy from renewable sources has been constantly increasing over the last dozen years [58], as illustrated in Figure 4.7. Under the assumption that this trend will continue, it is likely that

the CO₂ emission factor for public electricity and heat generating around the world will decrease over time.

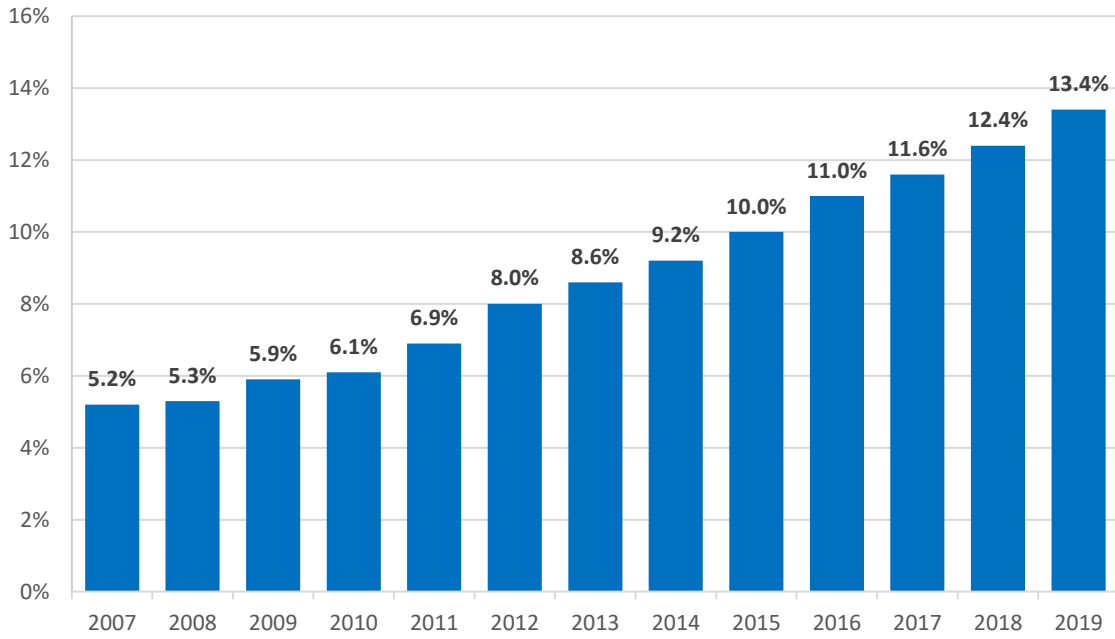

Figure 4.7: Share of renewable power in electricity generation worldwide

5. Case study

5.1. Process data

The production data provided corresponds to a gas-condensate field located in the North Sea. Gas condensate reservoirs are characterized by the production of free gas and a condensate mixture having a low density and a high API gravity. During production from such reservoirs, some complications might arise due to the pressure sensitivity of some condensates, meaning that some of the components that make up the reservoir's fluid can switch from one phase to the other with changing pressures [59]. When brought to the surface, the produced hydrocarbon stream therefore requires a treatment process to separate the natural gas from the heavier condensates and stabilize the final products to meet final pipeline and market specifications.

Accordingly, the product export specifications are as follows:

- Oil/condensate: True vapor pressure at 37.8 °C must be below 1 atm and the oil export pressure should be of 10 bar.
- Gas: Cricondenbar pressure must be below 105 bar and the gas export pressure must be of 200 bar.

The initial well stream composition is presented in Table 5.1 and the physical properties of the hypo components involved is presented in the Table 5.2. Also, the production profile of the offshore gas installation is provided in Table 5.3.

Table 5.1: Initial well stream composition

Composition	mol fraction
Nitrogen	6.55E-03
CO ₂	0.024798468
Methane	0.819148398
Ethane	6.66E-02
Propane	3.59E-02
i-Butane	5.28E-03
n-Butane	1.06E-02
i-Pentane	3.00E-03
n-Pentane	3.60E-03
C6*	3.34E-03
C7*	4.44E-03
C8*	3.82E-03
C9*	2.32E-03
C10-C11*	3.23E-03
C12*	1.08E-03
C13-C14*	1.75E-03
C15-C16*	1.20E-03
C17-C18*	8.04E-04
C19-C22*	9.26E-04
C23-C29*	7.47E-04
C30-C40*	5.88E-04
C41-C80*	3.62E-04

Table 5.2: Properties of the hypo components contained in the well stream.

	Normal boiling point [°C]	MW	Liquid density [kg/m³]	Tc [C]	Pc [kPa]	Vc [m³/kgmol]	Acentricity
C6*	68.75	84.70	667.60	234.25	2968.85	0.37	0.30
C7*	91.95	91.00	738.90	265.23	3436.46	0.45	0.45
C8*	116.75	104.80	762.00	290.20	3002.75	0.48	0.49
C9*	142.25	121.00	768.20	314.97	2552.00	0.54	0.54
C10-C11*	175.50	139.57	786.92	341.45	2258.80	0.61	0.59
C12*	208.35	161.00	804.00	368.33	2018.15	0.68	0.65
C13-C14*	236.37	181.82	820.19	392.67	1861.11	0.76	0.71
C15-C16*	273.40	212.81	839.09	425.27	1692.55	0.89	0.79
C17-C18*	306.25	243.70	853.46	454.79	1572.92	1.02	0.86
C19-C22*	341.70	279.11	867.52	486.54	1479.22	1.18	0.94
C23-C29*	404.30	343.08	890.81	539.12	1387.98	1.49	1.07
C30-C40*	485.03	463.93	925.43	584.51	1246.78	2.12	1.26
C41-C80*	586.85	687.19	1008.30	727.63	1345.95	3.43	1.31

Table 5.3: Production profile of the offshore gas installation

Year	Well stream [BSm³/y]
2018	5.3
2019	4.8
2020	5
2021	5.5
2022	5.6
2023	4.6
2024	4.5
2025	5.3
2026	4.3
2027	4.6
2028	5
2029	4.8
2030	4.6
2031	4.7
2032	4.5
2033	4.3
2034	4.2
2035	3.5
2036	3.4
2037	3.1
2038	2.7
2039	2.2
2040	1.5
2041	1.1
2042	0.75
2043	0.55

5.2. Scenarios

Different process models were created including a reference case and two other proposed scenarios to compare the energy requirements and the environmental impact of each configuration. In the first scenario (GT+WHRU), energy requirements are met by local energy generation using a conventional gas turbine (GE LM2500+G4) coupled with a waste heat recovery unit to supply heat for the process. This is the most widely used energy supply method in offshore oil and gas installations and is therefore considered to be the reference case, to which the other scenarios will be compared. The second scenario (GT+WHRU+SC) corresponds to the use of a gas turbine with a waste heat recovery unit, coupled with a steam bottoming cycle for the exploitation of waste heat for additional power generation; this setup increases the utility plant's efficiency compared to GT+WHRU. The necessary data regarding the GT+WHRU+SC scenario, namely net plant efficiency (51.7%) and carbon emissions (385 kg CO₂ /MWh), were retrieved from a simulation by Nord et al. [60] and fitted into the case study. Finally, the third scenario (PFS) involves the full electrification of the offshore platform by importing power from the onshore electricity grid to run the hydrocarbon processing unit; in this scenario the Nordic CO₂ emission factor (0.06 kg CO₂ /kWh [61]) is taken as a reference, upon which, the final results of this simulation are based.

The proposed design configurations will then form the base cases of this study, upon which, process optimizations will be made to minimize energy demands of the processing block and eventually determine the best setup from both the energy supply and the energy demands sides.

5.3. Assumptions

To simplify the simulation of potential design configurations, some assumption had to be applied. These assumptions render the whole work simpler and more manageable in the timeframe given to conduct this research. Nevertheless, this master's thesis aims at paving the ground for future research that can further validate the key findings of this paper.

The key assumptions taken are as follows:

- Process inlet conditions are constant throughout the entire production lifetime of the field and correspond to an inlet pressure of 20 bar and an inlet temperature of 40 °C.
- The composition of the produced hydrocarbon stream is constant throughout the entire production lifetime of the field.
- No water or gas injection for enhanced oil and gas recovery.
- No water production throughout the production lifetime of the field.
- Compressors' and pumps' adiabatic efficiency of 75%.
- The offshore installation is always fully operational during the production lifetime of the gas field.
- For the GT+WHRU and GT+WHRU+SC setups, source energy is determined by the heat content of the amount of natural gas fuel consumed.
- For the PFS scenario, source energy is determined by the amount of electricity supplied from the grid, taking into account only the transmission losses and neglecting conversion losses from onshore power plants.
- Transmission losses from the grid are of 8% for the PFS scenario.
- Electricity is only imported from the Nordic electricity grid in the PFS scenario.

6. Results and discussions

The given process data, namely well stream inlet temperature, pressure, and composition, were compiled in Aspen HYSYS and several design simulations were generated accordingly. The goal is to generate a reference process design where the produced hydrocarbons meet the products' export specifications. The first objective of these simulations is to compare the energy requirements of the process as well as the cumulative CO₂ emissions when coupled with each of the shortlisted energy supply methods. Once the energy supply method with the lowest cumulative CO₂ emissions is determined, a thorough analysis of the possibilities and limitations of the chosen method is used as basis for process optimizations to minimize energy consumption of the system. By the end of this chapter, a complete solution of the most promising design setup that jointly considers energy supply and demand is presented.

6.1. Energy supply determination

Choosing the right energy supply method can have the greatest impact on energy related CO₂ emissions due to the large number of proposed concepts with varying environmental impacts. Therefore, a process design was generated and the shortlisted energy supply methods in Chapter 5.3 were simulated and compared.

6.1.1. Process description and results

In this section, a description of the different parameters and the thought process behind the design of the generated configuration (Figure 6.1) will be illustrated.

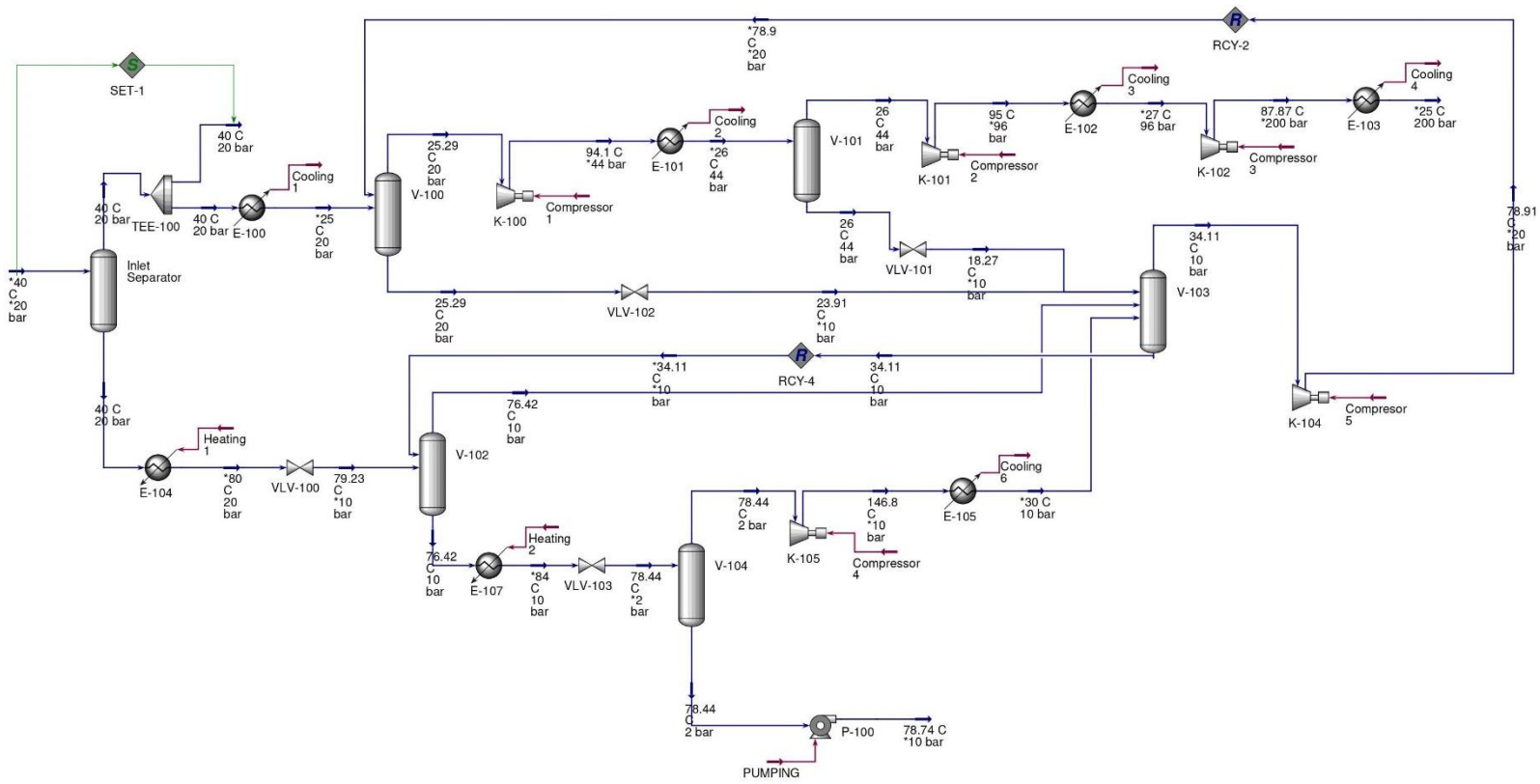

Figure 6.1: Generated process design configuration in Aspen HYSYS

At the inlet, the produced stream with a temperature of 40°C and a pressure of 20 bar enters a two-phase separator (Inlet Separator) with a gas outlet from the top and a liquid hydrocarbon outlet from the bottom. The cricondenbar pressure of the gas stream exiting at the top is of 116.7 bar as how in Figure 6.2.

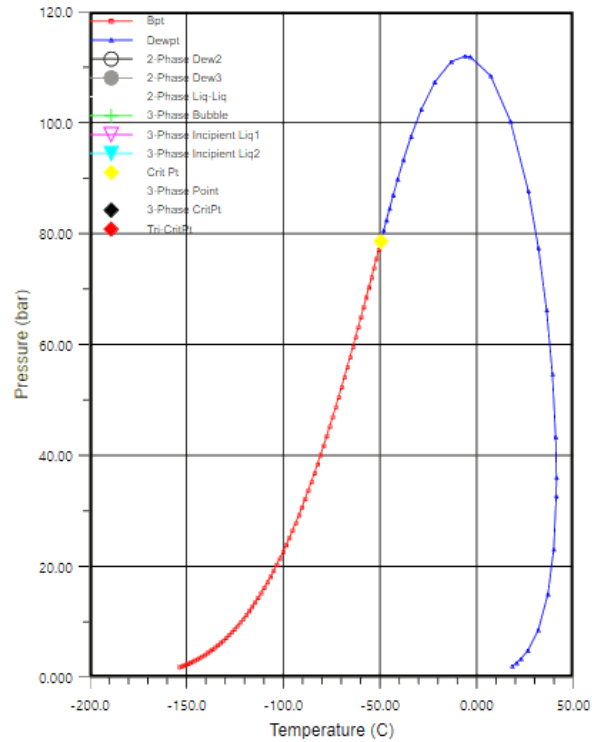

Figure 6.2: Phase envelope of the rich gas stream exiting the inlet separator

From the vapor outlet, the product enters a cooling, separation and compression train that reduces the phase envelope of the rich gas and obtain a final product stream that meets the pipeline specifications. A first stage cooling (E-100), where the gas temperature is brought down to 25 °C, causes some heavier hydrocarbons to condensate. The stream is introduced into a second stage scrubber (V-100) where the condensate is removed from the mixture and the obtained vapor has a cricondenbar pressure of 107 bar as shown in Figure 6.3.

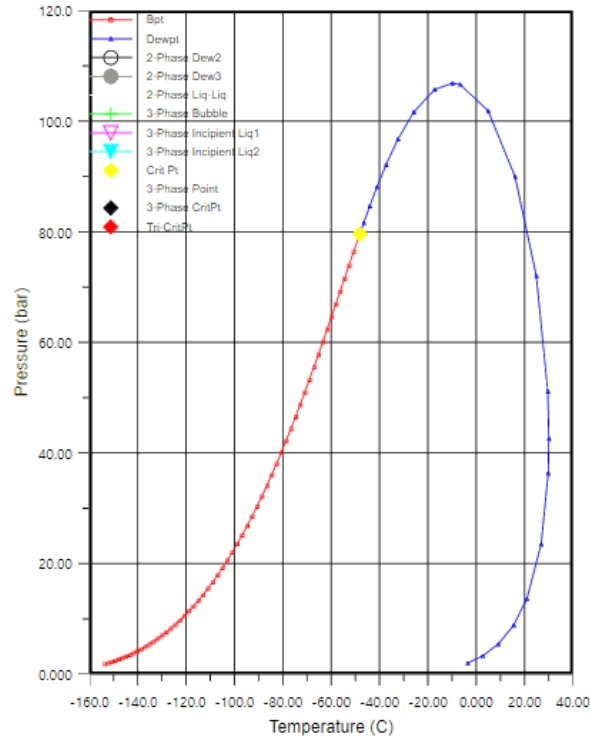

Figure 6.3: Phase envelope of the rich gas stream exiting the first stage scrubber.

The stripped gas then enters a first stage compressor (K-100) with a compression ratio of 2.2, increasing the pressure of gas stream to 44 bar. The compressed hot gas is then subject to a second stage cooling (E-101) and its temperature is brought down to 26 °C. The increase in pressure followed by cooling of the stream forces more of the intermediate and heavy hydrocarbons to pass into the liquid phase. The stream is therefore introduced again into a third stage scrubber (V-101) to strip the gas from the liquid hydrocarbons. Following its exit from V-101, the stripped gas meets the cricondenbar specification of the pipeline and has a cricondenbar pressure of 104.5 bar as demonstrated in the Figure 6.4.

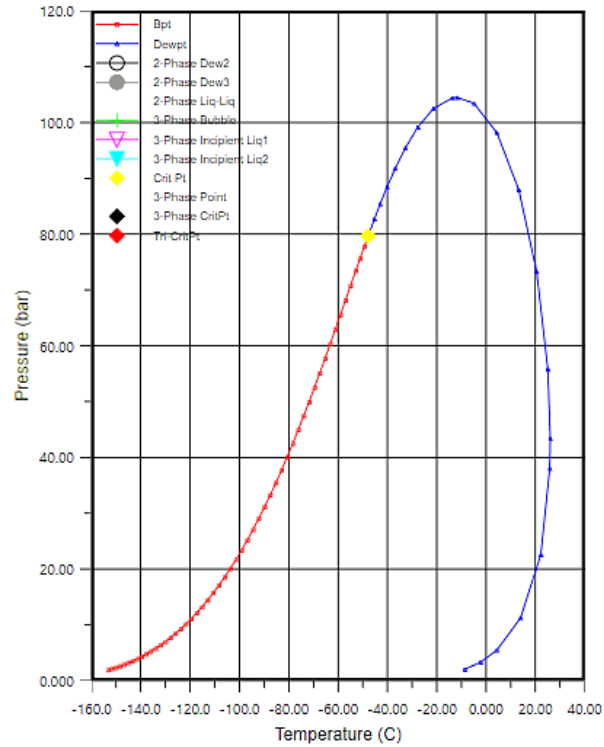

Figure 6.4: Phase envelope of the rich gas stream exiting the second stage scrubber.

From this point on, the gas stream is submitted to two more stages of compression and cooling. In the second stage compression (K-101), pressure is increased to 96 bar by a compressor with a compression ratio of 2.18. The material stream is again cooled down (E-102) to 27 °C and directed into the third and last compression stage (K-102) that will increase the pressure up to the specified export pressure of the rich gas, which is 200 bar. The rich gas undergoes a last cooling step (E-103) down to 25 °C before being exported through pipeline. With the given process data assumption of no production of water throughout the lifetime of the field, it would be possible to further cool down the natural gas in the compression train and reduce the power consumption of the compressors. However, a higher temperature was chosen to mimic real-life practices where the formation of gas hydrates can disrupt the process if the natural gas stream was cooled by a bigger margin.

From the liquid hydrocarbon outlet, the product enters a separation train to stabilize the oil and condensate products. Before entering the first stage separator, the liquid mixture is

heated (E-104) to a temperature of 80 °C to boil off some volatile hydrocarbons, and depressurized (VLV-100) to 10 bar. The stream enters a first stage separator (V-102) and the oil to be stabilized is recuperated from the bottom. In order to provide stable oil at the end of the process, the final product needs to be stabilized at atmospheric pressure. However, a common practice in the oil and gas industry consists of stabilizing the oil at a higher temperature and therefore also a higher pressure. A heater (E-107) is installed at the liquid outlet of V-102 to increase the temperature of the oil from 75.3 °C to 84 °C, after which, the flow is depressurized (VLV-103) down to 2 bar. A second and final stage separator (V-104) is used to remove the remaining volatile compounds. The liquid stream exiting V-104 is stable oil with a true vapor pressure of 0.996 atm at 37.8°C. The oil is finally pumped (P-100) to the desired export pressure of 10 bar.

For the gas recompression process, a single recompression stage is found to be sufficient for running the process. The vapor stream from the third separation stage (V-104) on the oil side is compressed to a pressure of 10 bar (K-105), cooled down to 30°C (E-105), and then introduced into a separator (V-103) along with the vapor stream from the second stage separation (V-102) of the oil stabilization process. Liquid streams from the first and second stage separation of the gas (V-100 and V-101) are depressurized to 10 bar and introduced to V-103 as well. The vapor phase exiting V-103 then enters a compressor (K-104) from which it discharges at a pressure of 20 bar and is recirculated through the second stage separator from the gas side (V-100). The liquid phase coming from V-103 is recycled into the second stage separator from the oil side (V-102). Recycling gas into the process helps in controlling the volume of gas entering the compressors and therefore, prevents compressor surge issues.

A sour gas treatment process was not included in the design because the produced gas does not contain any sulfur contaminants to be removed. In addition, the amount of CO₂ present in the rich gas is relatively low (2.442 mole %) and meets the pipeline requirement of a maximum of 2.5 mole % of CO₂.

A gas dehydration process was also not included in the simulation due to the assumption that there is no free nor dissolved water production throughout the lifetime of the field.

In the simulations where a gas turbine unit was the main energy supply method, namely the GT+WHRU and GT+WHRU+SC scenarios, a fraction of the natural gas is being directly taken after the first stage separator to fuel the gas turbine (TEE-100). It was found to be necessary to factor in the amount of natural gas used as fuel because this will impact the power demands of the system and therefore the overall energy requirements. Since the composition of the produced gas is assumed to be constant throughout the whole production lifetime of the field, power and heat requirements were found to be directly proportional to the yearly production of hydrocarbons. Function SET-1 was used to set the natural gas fuel flow rate into the gas turbine depending on the requirement of the utility plant; in the PFS scenario, SET-1 was given a value of zero. The amount of gas that had to be redirected into the gas turbine inlet is dependent on the net plant efficiency of the chosen setup for the utility plant and was therefore determined using the net plant efficiency formula for both GT+WHRU and GT+WHRU+SC.

The thermal efficiency of the GE LM2500+G4 gas turbine is equal to 39.3% and is provided by the manufacturer's product spec sheet [62]. However, considering that a WHRU is included in the setup to satisfy the heating demands of the process, the net plant efficiency for the GT+WHRU setup was computed and was found to be equal to 41.7%. On the other hand, as presented by Nord et al. [60], the net plant efficiency of the GT+WHRU+SC setup is equal to 51.7%.

Determining a specific LHV of the natural gas involved in this study falls outside the scope of this research paper, therefore a LHV of 50 MJ/kg was retrieved from literature [63] and used in the calculations.

Natural gas and condensate exports over the production lifetime of the field are shown in Table 6.1, and their composition is presented in Table 6.2.

Table 6.1: Product export from the offshore gas installation

Year	Rich gas (Sm³/h)	Stabilized Oil (Sm³/h)
2018	590300	119.1
2019	534700	107.9
2020	556900	112.3
2021	612600	123.6
2022	623700	125.8
2023	512400	103.4
2024	501200	101.1
2025	590300	119.1
2026	479000	96.62
2027	512400	103.4
2028	556900	112.3
2029	534700	107.9
2030	512400	103.4
2031	523500	105.6
2032	501200	101.1
2033	479000	96.62
2034	467800	94.38
2035	389800	78.65
2036	378700	76.41
2037	345300	69.65
2038	300700	60.67
2039	245000	49.44
2040	167100	33.71
2041	122500	24.71
2042	83540	16.85
2043	61260	12.36

Table 6.2: Composition of export products

	Rich gas	Stabilized oil
Nitrogen	0.00672	0.00000
CO2	0.02442	0.00031
Methane	0.83977	0.00090
Ethane	0.06920	0.00306
Propane	0.03631	0.01928
i-Butane	0.00514	0.01088
n-Butane	0.01003	0.03289
i-Pentane	0.00252	0.02206
n-Pentane	0.00284	0.03347
C6*	0.00180	0.06437
C7*	0.00096	0.14196
C8*	0.00027	0.14443
C9*	0.00003	0.09303
C10-C11*	0.00000	0.13090
C12*	0.00000	0.04380
C13-C14*	0.00000	0.07098
C15-C16*	0.00000	0.04867
C17-C18*	0.00000	0.03261
C19-C22*	0.00000	0.03756
C23-C29*	0.00000	0.03030
C30-C40*	0.00000	0.02385
C41-C80*	0.00000	0.01468

6.1.2. Process energy demands

Once the process simulations of the different scenarios were generated, the duty and power of the different process equipment, namely compressors, pumps, and heaters, was collected and compiled in a table. Consequently, heat and power demands of the different systems were aggregated under total site energy requirements, and a distinction between site energy and source energy for each setup is highlighted.

In order to obtain the yearly energy requirements of the simulated process (between 2018 and 2043), a case study was created in Aspen HYSYS where the changing variable was the inlet flow rate to cover the whole production profile of the offshore gas installation. The results of the simulation for the three different setups can be found in Figure 6.5.

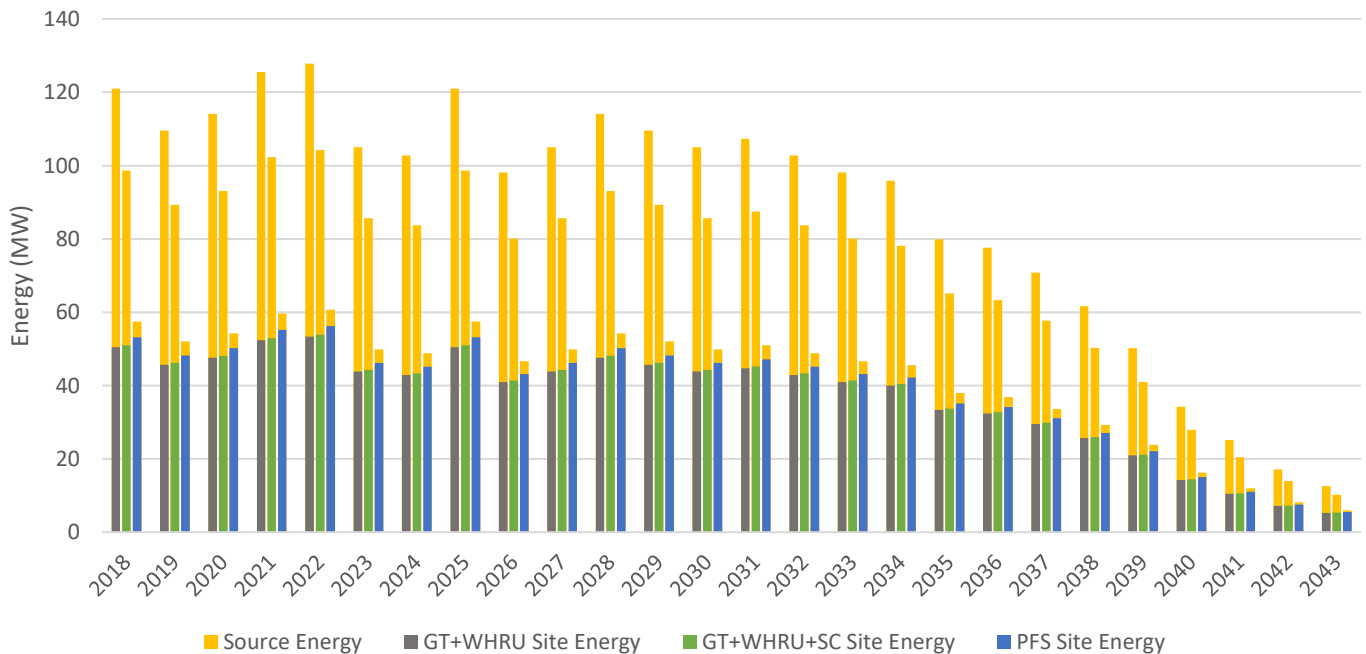

Figure 6.5: Source energy and site energy of the three simulations

On a yearly basis, total site energy requirements for the reference case (GT+WHRU) are lowest compared to the other proposed solutions, followed by the implementation of GT+WHRU+SC and finally PFS with the highest energy consumption. This difference is caused by the variation of the amount of natural gas that enters the compression train. When comparing the scenario of GT+WHRU+SC to GT+WHRU, the former has a higher net

plant efficiency (51.7%) compared to the latter (41.7%), which requires a lesser amount of fuel to meet the process' total energy requirements. This results in a higher amount of natural gas entering the compression train, which therefore requires more power. It is to be noted though that site energy requirements for GT+WHRU+SC are only 1% higher than for GT+WHRU on a yearly basis, nevertheless, this difference illustrates the effect of having a higher amount of natural gas to be processed. Following the same logic, in the PFS scenario the entire flow of the natural gas extracted is driven into the gas compression train, resulting in even higher power requirements for running the process compared to the reference case. Therefore, site energy for the PFS scenario is 5.16% higher than in GT+WHRU.

Source to site ratios were then computed for each of the simulated energy supply concepts. For GT+WHRU, the source to site ratio is of 2.4, however for GT+WHRU+SC, the source to site ratio lower and is equal to 1.95. The difference between the obtained numbers is due to difference in the efficiency that each plant exhibits when it comes to the conversion of natural gas to power and heat. For both scenarios, site energy was nearly identical, but the amount of natural gas fuel used in GT+WHRU+SC is lower than in GT+WHRU, which translates into lower source energy for the former setup. In offshore oil and gas installations, turbine exhaust gases can be a source of internal energy supply and can be coupled with several technologies, as presented in Chapter 4.2, to exploit the remaining available energy and increase the utility plant's efficiency; the use of a steam bottoming cycle accomplishes that and therefore justifies the difference in the numbers obtained. In the PFS scenario, source to site ratio was found to be of 1.08; the computed number is only influenced by the transmission losses from the onshore grid to the offshore gas installation.

The calculated source to site ratios for each energy supply concept present an indication of the inefficiencies that each setup exhibits. Therefore, the reduction of these parameters must be investigated to increase the performance of the proposed solutions.

6.1.3. Carbon dioxide emissions

Cumulative carbon dioxide emissions were computed over the whole lifetime of the field for the different chosen scenarios in this study. In the PFS scenario, the Nordic carbon

emission factor for electricity generation [61] is adapted, whereas with regard to the GT+WHRU and GT+WHRU+SC scenarios, the amount of CO₂ released from the combustion of natural gas was multiplied by the required flow rate of the fuel into the gas turbine for each of the two setups. The results are shown in Figure 6.6.

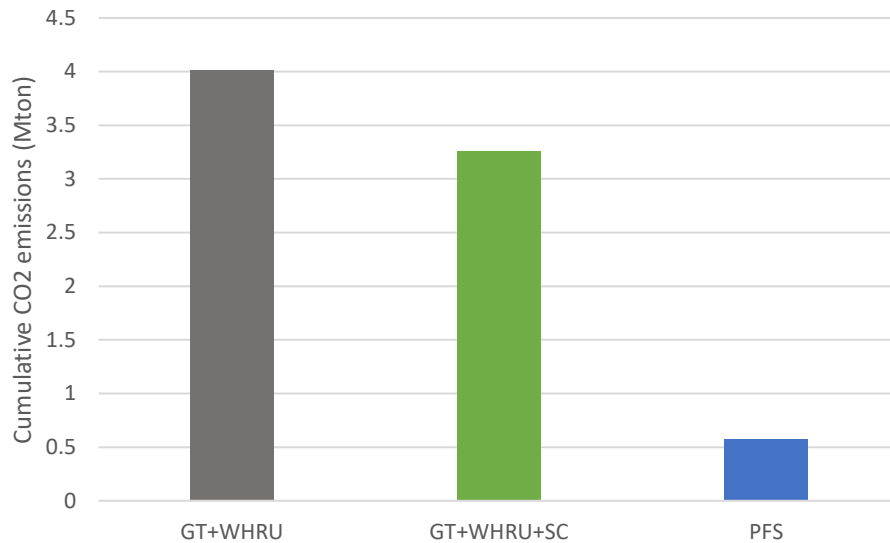

Figure 6.6: Cumulative CO₂ emissions of the proposed energy supply concepts

When comparing the three different scenarios, cumulative CO₂ emissions from the GT+WHRU setup are the highest, accounting for 4.01 Mton of CO₂ emitted over the production lifetime of the field. When applying GT+WHRU+SC, cumulative CO₂ emissions are reduced by 19% in relation to the reference case and are equal to 3.25 Mton. Finally, if the offshore gas installation was to be electrified (PFS), cumulative CO₂ emissions could be reduced by an impressive 85.8% compared to the reference case and thus exhibit the lowest cumulative emissions amongst the proposed concepts with 0.57 Mton of CO₂ emitted. Therefore, when evaluating the different concepts for energy supply, importing power from the onshore grid to run the offshore gas processing plant seems to be the most promising alternative for the reduction of CO₂ emissions.

The variations in the results displayed in Figure 6.6 underline the payoffs of selecting a proper energy supply method when looking to reduce the environmental impact of offshore oil and gas installations.

Considering the PFS scenario, the system exhibited the highest site energy requirements compared to the two other proposed concepts, however, its attributed CO₂ emissions were the lowest. This is simply related to the source from which energy is supplied for the offshore gas installation. The results are based on the assumption that electricity is provided from the neighboring Nordic countries, where the carbon emission factor for electricity production is relatively low because of the large share of renewable energy, as illustrated in Chapter 4.4.2. Therefore, the energy provided to run the offshore gas installation in the PFS scenario comes mostly from clean energy sources with very low carbon emissions. Nevertheless, the advantages of platform electrification might be overturned if the imported power came from an onshore electricity grid that relies more heavily on fossil fuels and thus has a relatively high carbon emission factor. In this case, it might become more favorable to consider local energy generation solutions, knowing that importing power from shore will further suffer from transmission losses. A detailed analysis concerning the impact of a change in the carbon emission factor for electricity production on the PFS concept falls outside the scope of this master's thesis and thus the results are solely based on the Nordic setting.

When comparing GT+WHRU to GT+WHRU+SC, the difference between cumulative CO₂ emissions can be attributed to the lower source to site energy ratio. The superior conversion of primary fuel to secondary energy (power and heat) played a major role in limiting the environmental impact of the offshore gas processing activities, highlighting the benefits of increasing energy efficiency and supporting the claims presented in Chapter 2.3.

6.2. Process optimization

Once the different energy supply concepts were analyzed and their environmental impact assessed, optimizations regarding the process' energy demands were conducted. From the first assessment, importing power from shore exhibited the highest emission savings compared to the other proposed alternatives, and was therefore the chosen energy supply

method, upon which, optimizations will be based. To determine where process optimizations would have the best possible outcome, it is necessary to investigate the shortcomings of platform electrification.

A noticeable difference between the setups involving the operation of a gas turbine and the concept of importing power from shore is the possibility to exploit additional energy from the utility plant and optimize the energy supply method. In the former setups, thermal energy is readily available and is recovered from the hot turbine exhaust gases to increase the system's efficiency, however in the latter, electricity powers the different sections of the processing unit, which leaves little to no room for additional energy recovery from the utility plant of the offshore gas installation.

Starting from this statement, optimizations with regards to utilizing the processing block's recoverable energy by means of internal heat recovery are evaluated, along with their effect on the site to source energy ratio.

6.2.1. Process description and results

Using basic thermodynamic principles and after observations regarding the different physical and thermodynamic properties of the material and energy streams, it was found that some material streams have relatively high temperatures and can therefore provide useful heat for some sections in the process.

In the gas compression train, natural gas is discharged from each compressor stage at a high temperature before being cooled again. Following this process, heat is lost to the environment through the cooling circuit and not put into practical use. An internal heat recovery system is proposed to study the possibility of exploiting useful heat from the hot gas streams to supply the oil stabilization process and lower the overall energy requirements of the processing block in the PFS scenario. An optimized process design, designated by PFS+HX referring to the heat exchangers, is therefore generated and presented in Figure 6.7.

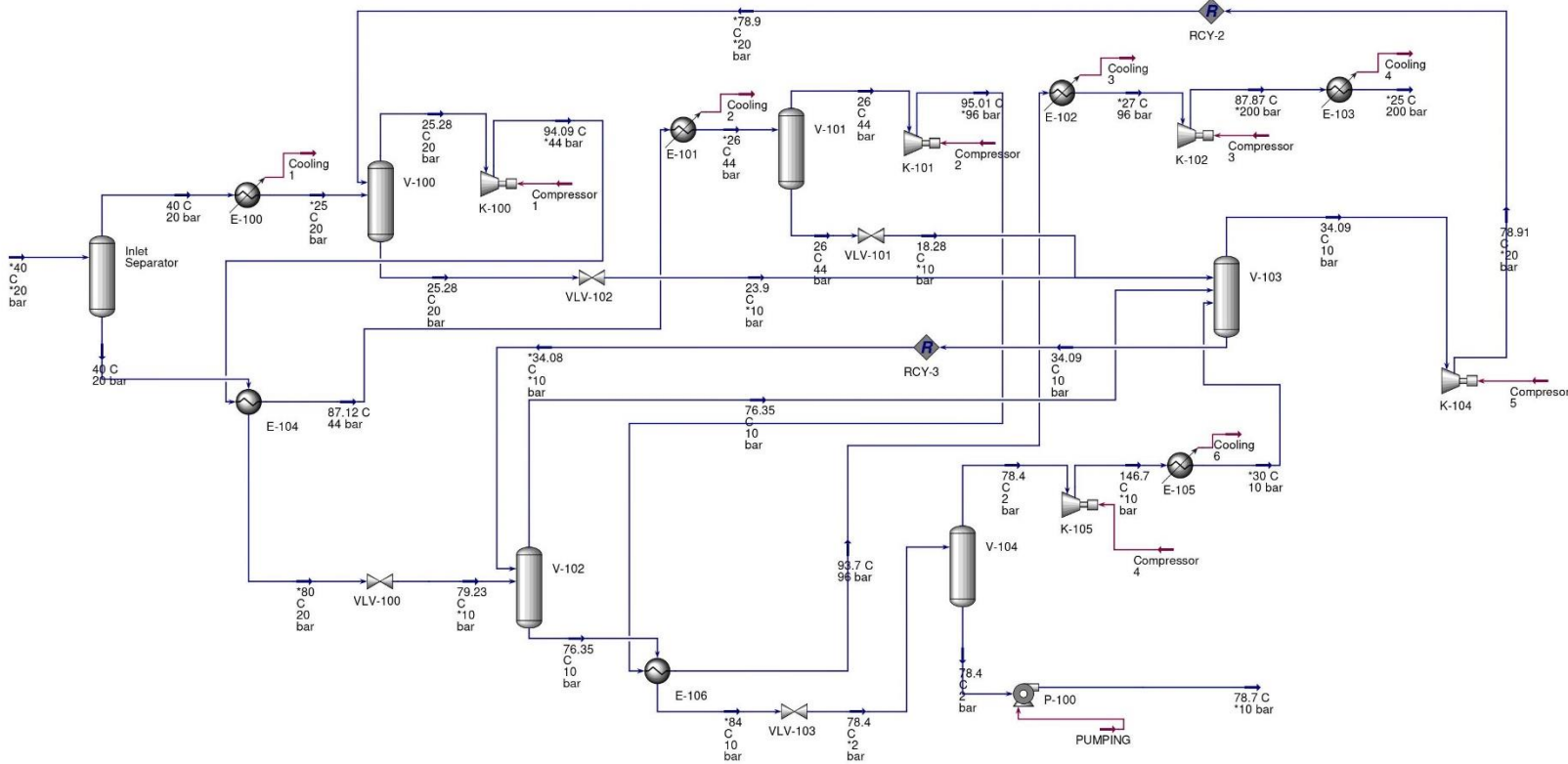

Figure 6.7: Process configuration of the optimized case

In this setup, two heat exchangers replace the two electric heaters used previously (E-104 and E-106). Shell and tube heat exchangers are the equipment of choice used in the simulation, where the hot utility fluid (compressed natural gas) passes through the shell and the cold utility fluid (oil/condensate) passes through the tubes. For the first heat exchanger, hot natural gas is taken after the first compression stage (K-100), and in the second heat exchanger, hot natural gas is taken after the second compression stage (K-101).

The choice of Heat exchangers that directly transfer heat from one process fluid to the other is based on the fact that the temperature of the hot compressed gases is classified as low temperature for heat recovery as presented in Chapter 4.2, hence the most efficient way to exploit the thermal energy from within the fluids is through direct heating.

A simple end point model for the heat exchanger was used in Aspen HYSYS where the only parameters to be specified are the cold utility fluid’s outlet temperature, corresponding

to 80°C after the first heat exchanger (E-104) and 84°C after the second heat exchanger (E-106), and the pressure drop on both the shell side and tube side which was assumed to be zero. The simulation of the process optimization yielded positive results, with the heat requirements of the system being completely satisfied through heat transfer from the hot gas streams in the compression train to the oil streams in the stabilization train. The results of the simple end point model only give information on the feasibility of the setup from a theoretical heat transfer perspective, regardless of the design limitations for the equipment. Nevertheless, the data and parameters corresponding to the simulated heat exchangers can be found in Annex A.

The inlet and outlet temperatures of the fluids from each heat exchanger are represented in Table 6.3.

Table 6.3: Fluids inlet and outlet temperatures from the heat exchangers

	E-104		E-106	
	Inlet T (°C)	Outlet T (°C)	Inlet T (°C)	Outlet T (°C)
Natural Gas	94.06	87.09	95.02	93.53
Oil/condensate	40	80	75.42	84

Economizers were the source of inspiration for the proposed methodology, as the heat exchangers used in the optimized process design serve a similar function, which is to preheat a fluid for a given process and therefore reduce energy consumption. Similar applications involving mechanical vapor recompression are also used in industry where pressurized gas streams are used to heat up processes to increase efficiency and lower energy consumptions.

6.2.2. Process energy requirements

Process optimization results showed that for the given hydrocarbon production data coupled with the simulated process design, internal heat recovery is sufficient to meet the process' heat requirements. Therefore, energy supply from the source (onshore electricity grid) is reduced by eliminating the energy needed for the electric heaters and its associated transmission losses, which results in a more attractive setup in terms of energy efficiency. The reduction in electricity supply from the onshore grid over the whole production lifetime of the field are presented in Figure 6.8.

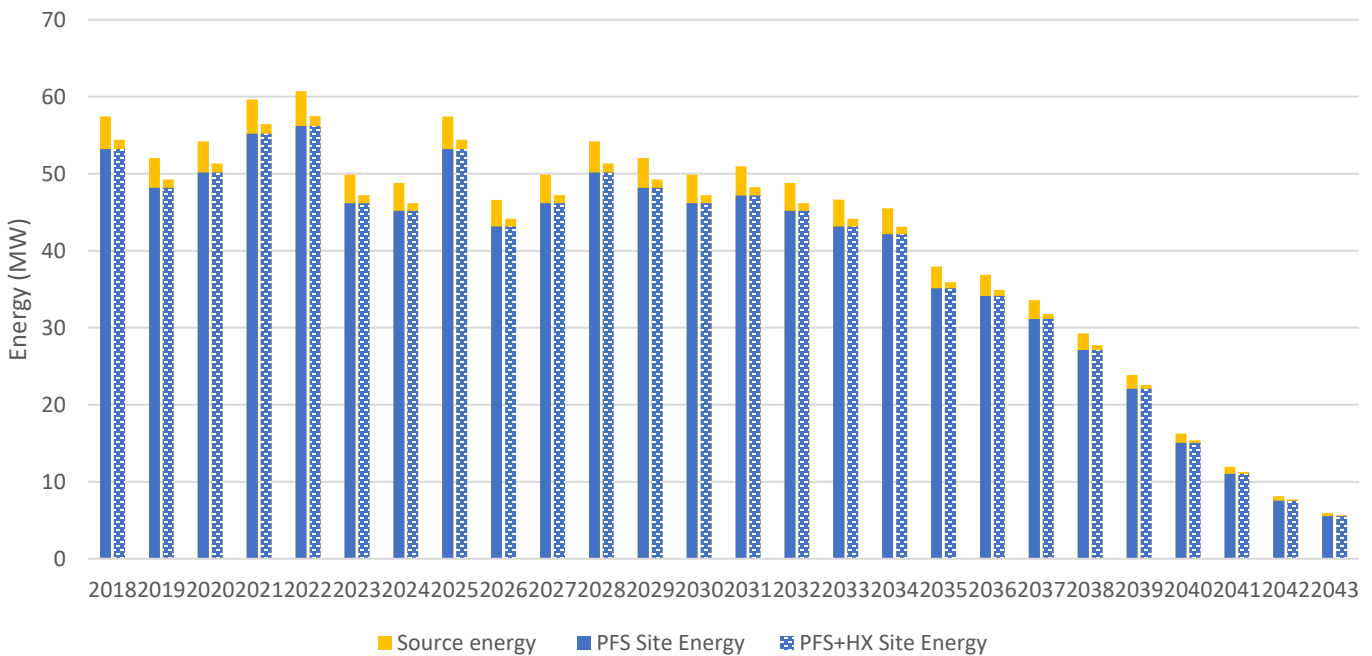

Figure 6.8: Source and site energy of PFS and PFS+HX

Internal energy supply from within the process was able to reduce electricity imports from the onshore grid by 5.6% from the total energy requirements on a yearly basis compared to the base case PFS scenario. Consequently, the source to site energy ratio was brought down from 1.08 in the base case to 1.02 in the optimized case.

Supplying heat for the process when considering electrification of offshore gas installations usually presents a drawback for this concept as stated in Chapter 4.3. The proposed solution contributes to reducing, or even eliminating the need for additional power to run the electric heaters and can perhaps serve as a starting point for further investigations regarding this

approach, which could render platform electrification as an even more attractive energy supply alternative for offshore gas installations.

In addition, despite the fact that a seawater cooling system was not included in the process design configuration since its contribution to the total energy demand would be minimal, it is evident that implementing the proposed internal heat recovery solution would also contribute to the decrease in power demand for the pumps involved in the seawater cooling system. This is because the temperatures of the hot compressed gases that are used in the internal heat recovery system drop partially upon exiting the heat exchangers as presented in Table 6.3. This will then require a smaller amount of cooling water to be circulated to achieve the desired temperatures in the gas compression train.

6.2.3. Carbon dioxide emissions

Following the determination of the yearly energy requirement of the optimized setup, a comparative analysis of cumulative CO₂ emissions between the base case (PFS) and the optimized case (PFS+HX) was conducted to assess the potential mitigation of carbon emissions when considering internal heat recovery in the system. The results can be found in Figure 6.9.

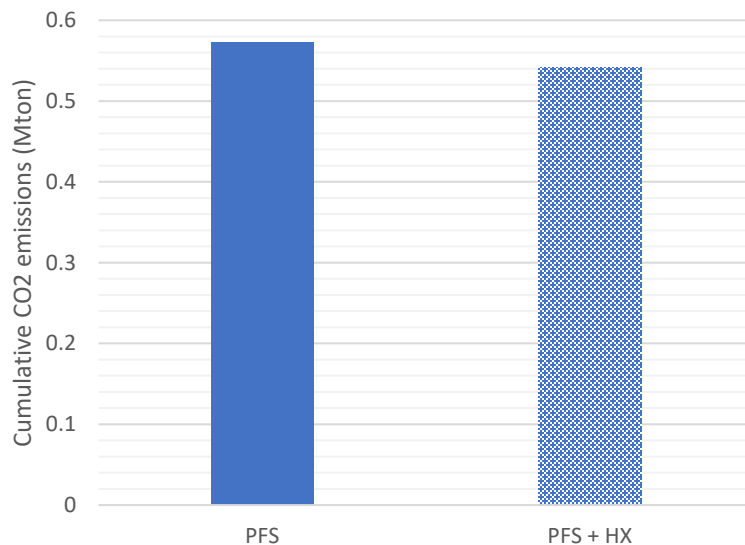

Figure 6.9: Cumulative CO₂ emissions of PFS and PFS+HX

It was found that applying an internal heat recovery system when importing power from the onshore grid results in total emissions reductions of 5.26% compared to the base case (PFS) with a total of 0.54 Mton CO₂ emitted over the entire production lifetime of the field. In comparison to the reference case (GT+WHRU), the base case (PFS) exhibited emission reductions of 85.8%, as presented in the previous results, and the optimized case (PFS+HX) allowed emission savings of 86.6%.

The additional CO₂ emission savings obtained when considering PFS+HX are not substantial, however, the numbers displayed proved that there is room for energy recuperation from within process fluids, which can therefore contribute the further reduction of the environmental impact of offshore gas installations. The reason behind that could be allocated to the relatively low heating requirements of the process, which account to roughly 5.3% of the total site energy requirements. As stated in the previous chapters, power requirements are mainly devoted to the gas compression process, and heating requirements are mainly determined by the oil separation and stabilization process. Knowing that the given data for the case study involved in this master's thesis corresponds to a gas condensate reservoir where the main export product is rich gas, the low heating requirements of the system are therefore justified. Moreover, the proposed solution could only serve to provide supplementary heat for the process, without investigating technologies for additional power generation from the recuperated heat. Its effectiveness is therefore directly linked to the heating requirements of the system.

6.3. Limitations

The shortcomings of the simulated designs are mainly attributed to assumptions taken to simplify the design and simulation of the offshore gas processing unit and the system boundaries established.

The only parameter that was manipulated to evaluate and compare cumulative CO₂ emissions was the inlet flow rate of the well stream, corresponding to the production profile of the offshore gas installation. The results obtained do not take into consideration the variations of the well stream temperature and pressure over the production lifetime of the field. Moreover, in real life, the changes in the composition of the well stream over

continuous production will have a great impact on power and heat requirements of the hydrocarbon processing unit and can impose severe limitations on the suggested process optimizations. Thus, a dynamic simulation that accounts for these operational changes is necessary to reach end results that more closely match real life scenarios.

Also, the results obtained are based on a simplified process design configuration that does not take into account some process sections whose input does not necessarily change the magnitude of the results nor the order of preference between the analyzed scenarios. However, these process sections, for example seawater pumping for the cooling circuit, must be accounted for when doing a complete thorough analysis of process energy requirements.

Specific utility plant optimizations were not done to perfectly fit the case study involved in this research. Decisive parameters, namely plant efficiency and load allocations for the gas turbine and bottoming cycles, were retrieved from literature and directly applied. Therefore, for a proper assessment and comparison of energy supply concepts, a detailed simulation that takes into consideration the process data at hand needs to be realized for more deterministic results.

The actual feasibility of the proposed internal heat recovery system when importing power from shore was not properly assessed from an economic and logistic point of view.

Finally, in the author's point of view, the shortlisted concepts for energy supply offshore are the most promising ones with regards to the current industry trends. However, due to the large number of proposed solutions in literature, some concepts might theoretically yield more attractive results when coupled with the given case study data.

7. Conclusion and future works

7.1. Conclusion

To sum up, the current global environmental situation is more sensitive than ever, and necessary action must be taken for climate change mitigation by limiting greenhouse gas emissions. Favoring the use of natural gas instead of other fossil fuels can provide major contribution in accelerating the transition towards a carbon neutral world, as it emits a substantially lower amount of CO₂ than other pollutants upon combustion. However, the extraction, processing, and transportation of natural gas from the reservoir to final consumers is an energy intensive process and is therefore a major source of CO₂ emissions. Oil and gas companies are therefore looking to reduce the environmental impact of oil and gas installations by implementing energy efficiency measures on both the supply and demand sides.

Throughout this master's thesis, an evaluation of the technical and environmental performances of different energy supply methods for an offshore gas processing unit was conducted and process optimizations were done accordingly. A process design configuration was generated using Aspen HYSYS and simulations of the following energy supply methods were run: A gas turbine coupled with a waste heat recovery unit, a combined cycle power generation consisting of a gas turbine with a steam bottoming cycle, and platform electrification by importing power from the onshore grid. The results showed that platform electrification is the most attractive setup with CO₂ emissions saving potential of 85.8% compared to supplying energy through a gas turbine coupled with a waste heat recovery unit, which was the reference case in this study.

Process design optimizations were then investigated in the scenario involving platform electrification. An internal heat recovery system consisting of recuperating the thermal energy from the hot gases in the compression train to provide heat for the oil stabilization process through heat exchangers was tested. The results showed that for the given process, internal heat recuperation completely satisfies the process' heat requirements and eliminates the need for electric heaters. Consequently, the total energy requirements of the system were decreased, as well as their affiliated CO₂ emissions. For the optimized case,

cumulative CO₂ emissions were 5.26% less in comparison to the base case and 86.6% less in comparison to the reference case.

Therefore, platform electrification coupled with heat utilization from process fluids proved to be the most beneficial setup in limiting the environmental impact of offshore gas installations and could potentially present a solution for the drawbacks of platform electrification when it comes to heat supply.

7.2. Future works

The results provided in this master's thesis can be complemented by additional research that can validate the feasibility of the proposed process optimizations, as well as to test other possibilities for internal heat recovery from within the process. A few suggestions on complementary work include:

- Study the effect of importing electricity to an offshore gas installation on the overall grid supply and make a detailed assessment of the concept's environmental impact.
- Test the actual feasibility of the proposed solution by designing a heat exchanger equipment and evaluate its implementation in an offshore setting.
- Techno-economic assessment of the implementation of the proposed internal heat recovery system.
- Investigate the possibility of exploiting the remaining heat from the compressed gas by low temperature heat recovery technologies such as ORC to supply additional power for the process.
- Evaluate the possibility of exploiting process heat from the gas dehydration and sour gas treatment processes, which were not simulated in this study.
- Make a proper assessment on the source to site ratio for the concept of platform electrification, taking into consideration the energy supply mix for the electricity grid.

Bibliography

- [1] Anonymous, “2050 long-term strategy,” *Climate Action - European Commission*, Nov. 23, 2016. https://ec.europa.eu/clima/policies/strategies/2050_en (accessed Feb. 02, 2021).
- [2] “World Energy Outlook 2018,” p. 661.
- [3] N. S. Ouedraogo, “Energy consumption and human development: Evidence from a panel cointegration and error correction model,” *Energy*, vol. 63, pp. 28–41, Dec. 2013, doi: 10.1016/j.energy.2013.09.067.
- [4] “1. What is climate change? | Australian Academy of Science.” <https://www.science.org.au/learning/general-audience/science-climate-change/1-what-is-climate-change> (accessed Jan. 13, 2021).
- [5] “What is carbon neutrality and how can it be achieved by 2050? | News | European Parliament,” Mar. 10, 2019. <https://www.europarl.europa.eu/news/en/headlines/society/20190926STO62270/wh-what-is-carbon-neutrality-and-how-can-it-be-achieved-by-2050> (accessed Dec. 25, 2020).
- [6] A. F. Townsend, “Natural Gas and the Clean Energy Transition,” p. 8.
- [7] “The Role of Gas in Today’s Energy Transitions – Analysis,” *IEA*. <https://www.iea.org/reports/the-role-of-gas-in-todays-energy-transitions> (accessed Dec. 21, 2020).
- [8] “Emissions savings – Multiple Benefits of Energy Efficiency – Analysis,” *IEA*. <https://www.iea.org/reports/multiple-benefits-of-energy-efficiency/emissions-savings> (accessed Feb. 18, 2021).
- [9] “Perspectives for the Energy Transition: The Role of Energy Efficiency – Analysis,” *IEA*. <https://www.iea.org/reports/the-role-of-energy-efficiency> (accessed Feb. 18, 2021).
- [10] N. G. Author, “Energy Efficiency as a Low-Cost Resource for Achieving Carbon Emissions Reductions,” 1219670, Sep. 2009. doi: 10.2172/1219670.
- [11] “The Role of Energy Efficiency in Long-Term Climate Change Planning,” *World Resources Institute*, Sep. 12, 2018. <https://www.wri.org/climate/expert-perspective/role-energy-efficiency-long-term-climate-change-planning> (accessed Feb. 18, 2021).
- [12] “Offshore Oil and Gas Production,” *Planète Énergies*. <https://www.planete-energies.com/en/medias/close/offshore-oil-and-gas-production> (accessed Jan. 27, 2021).
- [13] C. J. Cleveland and C. Morris, Eds., “O,” in *Dictionary of Energy (Second Edition)*, Boston: Elsevier, 2015, pp. 413–430.
- [14] “» Processing Natural Gas NaturalGas.org.” <http://naturalgas.org/naturalgas/processing-ng/> (accessed Jan. 28, 2021).
- [15] “Natural gas - Composition and properties of natural gas,” *Encyclopedia Britannica*. <https://www.britannica.com/science/natural-gas> (accessed Jan. 28, 2021).
- [16] “PHMSA: Stakeholder Communications - NG Processing Plants.” <https://primis.phmsa.dot.gov/comm/factsheets/fsnaturalgasprocessingplants.htm> (accessed Jan. 29, 2021).

- [17] “Midstream Gas: Gas Processing and NGL Markets.” https://www.ihrdc.com/els/po-demo/module14/mod_014_01.htm (accessed Jan. 29, 2021).
- [18] H. K. Abdel-Aal, “Natural Gas Processing,” *Pet. Eng.*, p. 9.
- [19] M. Netušil and P. Ditl, “Natural Gas Dehydration,” *Nat. Gas - Extr. End Use*, Oct. 2012, doi: 10.5772/45802.
- [20] R. K. Gupta, G. J. Dunderdale, M. W. England, and A. Hozumi, “Oil/water separation techniques: a review of recent progresses and future directions,” *J. Mater. Chem. A*, vol. 5, no. 31, pp. 16025–16058, Aug. 2017, doi: 10.1039/C7TA02070H.
- [21] S. Mokhatab, W. A. Poe, and J. G. Speight, Eds., “Chapter 9 - Natural gas dehydration,” in *Handbook of Natural Gas Transmission and Processing*, Burlington: Gulf Professional Publishing, 2006, pp. 323–364.
- [22] “Sour gas,” *PetroWiki*, Dec. 02, 2016. https://petrowiki.spe.org/Sour_gas (accessed Jan. 29, 2021).
- [23] “Acid Gas Removal | Koch-Glitsch.” <https://koch-glitsch.com/Applications/Acid-Gas-Removal> (accessed Jan. 29, 2021).
- [24] “The Global Syngas Technologies Council.” <http://www.globalsyngas.org> (accessed Jan. 29, 2021).
- [25] T. Ahmed, “Chapter 4 - PVT Properties of Crude Oils,” in *Equations of State and PVT Analysis (Second Edition)*, T. Ahmed, Ed. Boston: Gulf Professional Publishing, 2016, pp. 239–466.
- [26] “Oil and gas separators,” *PetroWiki*, Jan. 15, 2018. https://petrowiki.spe.org/Oil_and_gas_separators (accessed Jan. 21, 2021).
- [27] “What is a Compressor? - Definition from Corrosionpedia,” *Corrosionpedia*. <http://www.corrosionpedia.com/definition/4654/compressor-equipment> (accessed Feb. 21, 2021).
- [28] “Types of Pumps in Oil and Gas Industry | Upstream, Midstream, Downstream,” *Integrated Flow Solutions*, Jun. 25, 2019. <https://ifsolutions.com/types-of-pumps-in-oil-and-gas-industry/> (accessed Jan. 21, 2021).
- [29] B. Zohuri, “Chapter 12 - Heat Exchangers,” in *Physics of Cryogenics*, B. Zohuri, Ed. Elsevier, 2018, pp. 299–330.
- [30] “What is a Heat Exchanger? How do Heat Exchangers Work?” <http://www.thermex.co.uk/news/blog/160-what-is-a-heat-exchanger> (accessed Feb. 01, 2021).
- [31] “Understanding Heat Exchangers - Types, Designs, Applications and Selection Guide.” <https://www.thomasnet.com/articles/process-equipment/understanding-heat-exchangers> (accessed Jan. 29, 2021).
- [32] D. B. Spalding, “Handbook of heat transfer,” *Int. J. Heat Mass Transf.*, vol. 18, no. 10, p. 1221, Oct. 1975, doi: 10.1016/0017-9310(75)90148-9.
- [33] F. V. Hanson, “Heat exchangers selection, design and construction,” *Fuel Process. Technol.*, vol. 23, no. 1, pp. 87–88, Sep. 1989, doi: 10.1016/0378-3820(89)90046-5.
- [34] C. Borgnakke, R. E. Sonntag, G. J. Van Wylen, and R. E. Sonntag, *Fundamentals of thermodynamics*, 7th ed. Hoboken, NJ: Wiley, 2009.
- [35] “Compendium_TEP4185_2018.pdf.” .

- [36] “5 – Modeling and cycle optimization | Elsevier Enhanced Reader.”
<https://reader.elsevier.com/reader/sd/pii/B9780081008041000050?token=A6B1493CE3BB3C92AA65D2ABD669C9800013CE062E2B73F80602FC3E9EF243D00EB912DF9571C7C5322C6C6BA7982C54> (accessed Feb. 04, 2021).
- [37] U. Desideri, “3 - Fundamentals of gas turbine cycles: thermodynamics, efficiency and specific power,” in *Modern Gas Turbine Systems*, P. Jansohn, Ed. Woodhead Publishing, 2013, pp. 44–85.
- [38] “Waste heat recovery technologies and applications | Elsevier Enhanced Reader.”
<https://reader.elsevier.com/reader/sd/pii/S2451904918300015?token=646C749324282689AE273D23B90A7D62C55CAB18D43011365814A16F490182CF56355EB9B5AE90C3A01C0DD02FEDA4F7> (accessed Jan. 28, 2021).
- [39] A. Firth, B. Zhang, and A. Yang, “Quantification of global waste heat and its environmental effects,” *Appl. Energy*, vol. 235, pp. 1314–1334, Feb. 2019, doi: 10.1016/j.apenergy.2018.10.102.
- [40] S. Brückner, S. Liu, L. Miró, M. Radspieler, L. F. Cabeza, and E. Lävemann, “Industrial waste heat recovery technologies: An economic analysis of heat transformation technologies,” *Appl. Energy*, vol. 151, pp. 157–167, Aug. 2015, doi: 10.1016/j.apenergy.2015.01.147.
- [41] I. Johnson, W. T. Choate, and A. Davidson, “Waste Heat Recovery. Technology and Opportunities in U.S. Industry,” BCS, Inc., Laurel, MD (United States), Mar. 2008. doi: <https://doi.org/10.2172/1218716>.
- [42] S. C. Bhatia, “19 - Cogeneration,” in *Advanced Renewable Energy Systems*, S. C. Bhatia, Ed. Woodhead Publishing India, 2014, pp. 490–508.
- [43] “Combined heat and power,” *IPIECA*. <https://www.ipieca.org/resources/energy-efficiency-solutions/power-and-heat-generation/combined-heat-and-power/> (accessed Jan. 12, 2021).
- [44] “Combined cycle power vs cogeneration | Inoplex Cogeneration Australia.”
<https://www.inoplex.com.au/information/combined-cycle-power-vs-cogeneration> (accessed Feb. 04, 2021).
- [45] H. Jouhara, N. Khordehgah, S. Almahmoud, B. Delpech, A. Chauhan, and S. A. Tassou, “Waste heat recovery technologies and applications,” *Therm. Sci. Eng. Prog.*, vol. 6, pp. 268–289, Jun. 2018, doi: 10.1016/j.tsep.2018.04.017.
- [46] M. P. Boyce, “1 - Combined cycle power plants,” in *Combined Cycle Systems for Near-Zero Emission Power Generation*, A. D. Rao, Ed. Woodhead Publishing, 2012, pp. 1–43.
- [47] P. Breeze, “Chapter 7 - Combined Cycle Power Plants,” in *Gas-Turbine Power Generation*, P. Breeze, Ed. Academic Press, 2016, pp. 65–75.
- [48] B. Hoffschmidt *et al.*, “3.18 - Concentrating Solar Power,” in *Comprehensive Renewable Energy*, A. Sayigh, Ed. Oxford: Elsevier, 2012, pp. 595–636.
- [49] “ORC,” *EXERGY - ORC Generating electricity from low-medium temperature heat sources*. <https://www.exergy-orc.com/orc> (accessed Feb. 19, 2021).
- [50] K. Sipilä, “3 - Cogeneration, biomass, waste to energy and industrial waste heat for district heating,” in *Advanced District Heating and Cooling (DHC) Systems*, R. Wiltshire, Ed. Oxford: Woodhead Publishing, 2016, pp. 45–73.

- [51] L. Riboldi, S. Völler, M. Korpås, and L. O. Nord, “An Integrated Assessment of the Environmental and Economic Impact of Offshore Oil Platform Electrification,” *Energies*, vol. 12, no. 11, Art. no. 11, Jan. 2019, doi: 10.3390/en12112114.
- [52] J. I. Marvik, E. V. Øyslebø, and M. Korpås, “Electrification of offshore petroleum installations with offshore wind integration,” *Renew. Energy*, vol. 50, pp. 558–564, Feb. 2013, doi: 10.1016/j.renene.2012.07.010.
- [53] “The difference between source and site energy.”
<https://www.energystar.gov/buildings/facility-owners-and-managers/existing-buildings/use-portfolio-manager/understand-metrics/difference> (accessed Feb. 21, 2021).
- [54] “Power plant types determine the efficiency - Kraftwerk Forschung.”
<https://kraftwerkforschung.info/en/quickinfo/basic-concepts/power-plant-types-determine-the-efficiency/> (accessed Jan. 31, 2021).
- [55] “CO2 emission intensity — European Environment Agency.”
[https://www.eea.europa.eu/data-and-maps/daviz/co2-emission-intensity-5#tab-googlechartid_chart_11_filters=%7B%22rowFilters%22%3A%7B%7D%3B%22columnFilters%22%3A%7B%22pre_config_ugeo%22%3A%5B%22European%20Union%20\(current%20composition\)%22%3B%22Germany%22%5D%7D%7D](https://www.eea.europa.eu/data-and-maps/daviz/co2-emission-intensity-5#tab-googlechartid_chart_11_filters=%7B%22rowFilters%22%3A%7B%7D%3B%22columnFilters%22%3A%7B%22pre_config_ugeo%22%3A%5B%22European%20Union%20(current%20composition)%22%3B%22Germany%22%5D%7D%7D) (accessed Jan. 26, 2021).
- [56] “technical_annex_en.pdf.” Accessed: Jan. 26, 2021. [Online]. Available: https://www.covenantofmayors.eu/IMG/pdf/technical_annex_en.pdf.
- [57] “CO2 Intensity of Electricity Generation — European Environment Agency.”
<https://www.eea.europa.eu/data-and-maps/data/co2-intensity-of-electricity-generation> (accessed Jan. 26, 2021).
- [58] “Renewable power generation share worldwide 2019,” *Statista*.
<https://www.statista.com/statistics/489131/share-of-renewables-in-power-generation-globally/> (accessed Jan. 26, 2021).
- [59] L. Fan *et al.*, “Understanding gas-condensate reservoirs,” *undefined*, 2005.
[/paper/Understanding-gas-condensate-reservoirs-Fan-Harris/947f0f6128844c3334638325ae38efe17bb802c7](https://www.sciencedirect.com/science/article/pii/S0924646005000000) (accessed Feb. 16, 2021).
- [60] L. O. Nord, E. Martelli, and O. Bolland, “Weight and power optimization of steam bottoming cycle for offshore oil and gas installations,” *Energy*, vol. 76, no. C, pp. 891–898, 2014.
- [61] N. E. R. S. 25 N.-0170 Oslo and N. O. no: 984809255, “Relative CO2 intensity on downward path – Nordic Energy Research.”
<https://www.nordicenergy.org/figure/relative-co2-intensity-on-downward-path/> (accessed Feb. 05, 2021).
- [62] “datasheet-lm2500plusg4.pdf.” Accessed: Jan. 27, 2021. [Online]. Available: <https://www.geaviation.com/sites/default/files/datasheet-lm2500plusg4.pdf>.
- [63] “Fuels - Higher and Lower Calorific Values.”
https://www.engineeringtoolbox.com/fuels-higher-calorific-values-d_169.html (accessed Jan. 31, 2021).

Appendix A

This appendix shows the heat exchanger data from the process optimizations (Chapter 6.2)

Table A.1 Heat exchanger data

Year	E-104 - Overall U (W/m ² .K)	E-104 - Overall UA (W/K)	E-104 - Duty (MW)	E-106 - Overall U (W/m ² .K)	E-106 - Overall UA (W/K)	E-106 - Duty (MW)
2018	756.9	85610.0	2.3	308.2	34850.0	0.5
2019	685.5	77530.0	2.1	279.0	31550.0	0.4
2020	714.1	80760.0	2.2	290.6	32870.0	0.5
2021	785.5	88840.0	2.4	319.8	36170.0	0.5
2022	799.8	90450.0	2.5	324.9	36750.0	0.5
2023	657.0	74300.0	2.0	267.4	30240.0	0.4
2024	642.7	72690.0	2.0	262.2	29660.0	0.4
2025	756.9	85610.0	2.3	308.2	34860.0	0.5
2026	614.1	69460.0	1.9	249.8	28250.0	0.4
2027	657.0	74300.0	2.0	267.4	30240.0	0.4
2028	714.1	80760.0	2.2	290.6	32860.0	0.5
2029	685.5	77530.0	2.1	279.0	31560.0	0.4
2030	657.0	74300.0	2.0	267.5	30250.0	0.4
2031	671.3	75920.0	2.1	272.6	30830.0	0.4
2032	642.7	72690.0	2.0	262.1	29640.0	0.4
2033	614.1	69460.0	1.9	250.0	28280.0	0.4
2034	599.8	67840.0	1.9	244.8	27690.0	0.4
2035	499.9	56530.0	1.5	203.2	22980.0	0.3
2036	485.6	54920.0	1.5	198.2	22410.0	0.3
2037	442.7	50070.0	1.4	180.2	20380.0	0.3
2038	385.6	43610.0	1.2	157.0	17760.0	0.2
2039	314.2	35540.0	1.0	127.8	14460.0	0.2
2040	214.2	24230.0	0.7	87.1	9852.0	0.1
2041	157.1	17770.0	0.5	63.9	7226.0	0.1
2042	107.1	12110.0	0.3	43.6	4925.0	0.1
2043	78.6	8884.0	0.2	31.9	3613.0	0.1

