

Majbrit Hirche

Wood Weathering as Design Option

Thesis for the degree of Philosophiae Doctor

Trondheim, September 2014

Norwegian University of Science and Technology
Faculty of Architecture and Fine Art
Department of Architectural Design,
History and Technology



NTNU – Trondheim
Norwegian University of
Science and Technology

NTNU

Norwegian University of Science and Technology

Thesis for the degree of Philosophiae Doctor

Faculty of Architecture and Fine Art

Department of Architectural Design, History and Technology

© Majbrit Hirche

ISBN 978-82-326-0456-2 (printed ver.)

ISBN 978-82-326-0457-9 (electronic ver.)

ISSN 1503-8181

Doctoral theses at NTNU, 2014:272

Printed by NTNU-trykk

Contents

	Acknowledgements	7
	Summary	9
1	Introduction	11
1.1	Problem statement	15
1.2	Research objectives	15
2	Current state of the research field	19
2.1	Weathering of the wooden surface independent of a building context	19
2.2	Weathering of wooden claddings	21
2.3	Weathering color development related to elements in the building façade and the building envelope	22
2.4	Weathering color development related to factors in the near environment	23
3	Materials and methods	25
3.1	Developing a conceptual grasp for working with weathering of wooden claddings	25
3.1.1	Terms for describing weathering of untreated claddings	36
3.1.2	The Weathering Equation	36
3.1.3	Options for designing an untreated wooden cladding	37
3.1.4	Concepts on the relations between cladding design, weather exposure and weathering colors	45

3.2	Research design	49
3.2.1	Initial consideration on methods for developing weathering colors	49
3.2.2	Strategy for the experimental design	51
3.2.3	Design of cladding types for the experiment	53
3.2.4	Method for registration of weathering colors	72
3.3	Experimental procedures	73
3.3.1	Production of claddings for the experiment	73
3.3.2	Experimental setup at Voll research fields	74
3.3.3	Registration of weathering colors and display of the data	75
3.4.1	Directional Weather Map	80
3.4.2	Spherical Weather Map	82
3.4.3	Surface Weather Map	82
4	Results and Discussion	87
4.1	Method for analyzing the color development of the claddings	87
4.1.1	Identification and description of the weathering color patterns	87
4.1.2	Analysis of the color development	88
4.1.3	Deviations from the color pattern repeat	89
4.1.4	Display of the scanned images	89
4.1.5	Photos taken after five years of exposure	91
4.2	Characterization of weather towards the four experimental supporting frames at Voll research fields	91
4.3	Cladding 1	96
4.3.1	Weathering color pattern	96
4.3.2	Analysis of the color development	96
4.3.3	Edge effects	97
4.4	Cladding 2	104
4.4.1	Weathering color pattern	104
4.4.2	Analysis of the color development	104
4.4.3	Edge effects	108
4.5	Cladding 3	122
4.5.1	Weathering color pattern	122
4.5.2	Analysis of the color development	122
4.5.3	Edge effects	123

4.6	Cladding 4	136
4.6.1	Weathering color pattern	136
4.6.2	Analysis of the color development	136
4.6.3	Edge effects	136
4.7	Cladding 5	144
4.7.1	Weathering color pattern	144
4.7.2	Analysis of the color development	144
4.7.3	Edge effects	147
4.8	Cladding 6	160
4.8.1	Weathering color pattern	160
4.8.2	Analysis of the color development	160
4.8.3	Edge effects	160
4.9	Cladding 7	161
4.10	Cladding 8	174
4.10.1	Weathering color pattern	174
4.10.2	Analysis of the color development	174
4.10.3	Edge effects	175
4.11	Summary of the color development of the claddings	188
4.11.1	Claddings 1 and 4	188
4.11.2	Claddings 2 and 3	188
4.11.3	Claddings 5 and 6	189
4.11.4	Cladding 8	189
4.12	Weathering colors after five years of exposure	190
4.12.1	Claddings 1 and 4	190
4.12.2	Claddings 2 and 3	190
4.12.3	Claddings 5 and 6	190
4.12.4	Cladding 8	190
4.13	Evaluation of the experimental procedures	196
4.14	Evaluation of the weather maps	197

5	Discussion	199
5.1	Compass direction as a guideline for predicting color development of wooden cladding	199
5.2	The cladding geometry as a guideline for predicting weathering colors of wooden cladding	201
6	Suggestions for future research	203
7	References	209
	Appendix A	211
	Appendix B	217
	Appendix C	218

Acknowledgements

This project would not have been possible without the guidance, inspiration and encouragement from supervisors, colleagues, family and friends. I take this opportunity to express my gratitude to the people whose contribution has been vital to the success of this project:

Supervisor Professor Jan Siem, University of Science and Technology (NTNU), Department of Architectural Design, History and Technology taught me the basic principles of experimental design. His contribution ensured scientific robustness of applied methodology.

SINTEF Byggeforsk in Trondheim provided space for the experiments at the Voll research fields in Trondheim. The hospitality offered was essential to the execution of this work.

Dr. Steen Aagaard Sørensen collaborated in the analysis and modeling of weather data. The weather maps developed for this work were essential for understanding details in the color development and inspired new ideas on ways to work with wood weathering in architectural design.

Professor Per Jostein Hovde, Professor Knut Einar Larsen and Associate Professor Finn Hakonsen were driving forces in initiating the Strategic University Research Programme in wood as a building material at NTNU, funded by the Research Council of Norway. This project was part of the programme.

Professor Anne Grete Hestnes, NTNU, contributed with important critical comments in early stages of shaping this project.

Professor Olav Høibø and Professor Geir Vestøl at the Norwegian University of Life Sciences, UMB, Department of Ecology and Natural Resource Management, INA, offered working facilities during my studies in wood technology and equipped me with knowledge on wood technology essential for understanding the processes of wood weathering.

Dr. Lone Gobakken at The Norwegian Forest and Landscape Institute, UMB, generously shared her large expertise on wood inhibiting fungi.

Associate Professor Torben Dahl, former head of Institute of Technology at The Royal Danish Academy of Fine Arts Schools of Architecture, Design and Conservation, KADK, offered me hospitality as a guest researcher.

Norwegian Armed Forces allowed access and photographing of the wooden clad buildings at Rena Military Camp.

Architect Arvid Rønsen Ruud, LPO Architects in Oslo, provided building specifications on the wood façades at Rena Military Camp.

Architect Max Rieder provided building specifications on the wood façades at Aigen Kindergarten in Salzburg.

Einar Borgfjord and his skilful craftsmen at The Coastal Heritage Museum at Stadsbygd, Norway, did an outstanding job building the claddings for the experiment.

The Technical University of Denmark, DTU, Department of Civil Engineering offered me ideal working environment during the last critical phase of writing.

Associate Professor Staffan Svensson, Department of Civil Engineering, DTU, provided me outstanding mentorship and advice on the completion of this work. His whole-hearted emphasizing of the potentials of this work was a great inspiration and a personal motivation when times were tough.

Professor Ole Mejlhede Jensen, researchers and staff at the Department of Civil Engineering, DTU: It was a privilege and a pleasure to work in your highly dedicated and welcoming environment.

Dale Sadlik did a great job proof-reading.

Family and friends, I am grateful for your constant support. You know who you are.

Data and tools

Weather data from meteorological weather stations were used to develop the wind-driven rain visualization tools for this project.

Norwegian Meteorological Institute, provided weather data for Voll research fields used in the analysis of the experiments.

Zentralanstalt für Meteorologie und Geodynamik, ZAMG, provided weather data for Salzburg used in a study of the wooden façades at Aigen Kindergarten, designed by architect Max Rieder.

Federal Office of Meteorology and Climatology, MeteoSwiss, provided weather data for Disentis and Chur used in a study of the wooden façades of Haus Gugalun, designed by architect Peter Zumthor.

Max Planck Institute for solar system research provided the graphics library, DISLIN, used for visualization of the weather data.

Funding

The Norwegian Research Council provided an additional founding for this work.

Tresenteret in Trondheim, headed by Dr. Harald Landrø, provided sponsorship for materials that were used in the experiment.

Materialbanken at Røros, led by Jakob Trøan provided sponsorship of the wood used in the experiment.

Summary

The objective of the presented work is to provide a more thorough understanding of weathering colors and color patterns of untreated wooden claddings. The perspective taken throughout this work is that weathering is clearly an option for creating unique color settings on untreated wooden cladding and that a better knowledge of the color aspect of weathering will enable and encourage additional creative design in wood architecture. This approach is in direct contrast to the dominant view in the area of wood weathering research in which weathering is perceived as a negative consequence of weather exposure. Chapter 1 introduces the background of this study and specifies the research objectives. The current state of the research field is discussed in Chapter 2.

Established methods in wood weathering research were of little relevance to this study. Hence, a preliminary idea-generating exercise on ways to approach the topic was made. Chapter 3, Section 3.1 discusses the preliminary exercise.

The exercise resulted in four concepts for working with wood weathering:

- Terms for describing weathering of untreated cladding
- The Weathering Equation
- Options for designing an untreated wooden cladding
- Concepts on the relations between cladding design, weather exposure and weathering colors

The investigation of color development of untreated wooden claddings is based on data obtained from experiments. The overall idea for the experimental design was to create a setup that simulated conditions as closely as possible to real life weathering of wooden cladding in order to generate data with maximum comparability and relevance to real life situations. The experimental setup was designed to simulate a house with four vertical, perpendicular façades. A series of 8 different claddings was designed using untreated, planed, quarter sawn heartwood of Scots Pine (*Pinus Sylvestris L.*). Each design was produced in four samples and placed in an above ground vertical position on walls facing approximately cardinal compass directions at Voll research fields in Trondheim, Norway. Each sample measured 60x900mm. After 20 months of exposure, the claddings were disassembled and the surfaces scanned with a flatbed scanner in the same manner as one would scan a piece of paper. Chapter 3, Sections 3.2 and 3.3 discuss details of the experimental design, setup and procedures.

The scanned images showed significant variations in the color development of identical samples that had been exposed to weather from four different directions. Since wind-driven rain and solar radiation are the main weather factors responsible for color changes on untreated wooden surfaces, a separate study was undertaken of the distribution of these weather elements at the Voll research fields. This study is used in Chapter 4 to help understand details of the color development of the claddings. Using data from an automatic weather station located at the Voll research fields, three types of weather maps were designed:

- The Directional Weather Map. The map shows the main tendencies in the distribution of wind-driven rain, UV and sun hours on the horizon.
- The Spherical Weather Map. The map was designed to give an overview of the mean annual distribution of rain and solar radiation on the hemisphere above Voll.
- The Surface Weather map. The map was designed to visualize the distribution of wind-driven rain, UV and sun hours on the individual surfaces of the claddings in the experiment.

The information provided by the weather maps was used to establish the suggestion of a relationship between the Voll weather and the weathering color development of the claddings. Chapter 3, Section 3.4 discusses the weather maps. Details in the modeling and calculation methods are found in Appendix C.

The results documented that the four samples of each cladding type oriented towards four compass directions at the Voll research fields, developed differences in the weathering color and color patterns. The differences in color development could be explained by differences in weather incident on these four compass directions, as demonstrated by the weather maps. Chapter 4, Section 4.3-4.10 describes the weathering color development of the cladding and analyzes the relationship between cladding design, weather exposure and color development of the wood surfaces.

The results also showed that current guidelines on weathering of untreated wooden cladding are inadequate for evaluating the potential weather exposure conditions and the subsequent color development of wooden cladding. A critical hypothesis of this work is that knowledge of the specific in-situ weather conditions is necessary when determining the color potentials of any given wooden cladding. The weather maps designed for this work provide information on the specific in-situ weather conditions. Chapter 5 discusses the results of this study in relation to current guidelines on weathering of untreated wooden cladding.

The results obtained in this work point to a number of interesting options for further development of this field of research in ways that should appeal not just to the architectural profession but also to the general public, for whom the use of untreated wood and the ability to predict color outcomes in outdoor applications may be of interest. Chapter 6 discusses suggestions for future research.

1 Introduction

Untreated wooden building façades change color when exposed to weather in the form of precipitation and solar radiation. The general term for weather-induced changes on surfaces is weathering. Weathering is a surface phenomenon and must not be confused with the destructive processes of wood decay.

The colors of weathered wood include various grey and brown nuances. In addition nuances of brown colored extractives may emerge on the wood surface. Untreated wooden façades can develop beautiful color patterns as a result of the interplay of the cladding design and the actual weather exposure. Examples of interestingly weathered wooden façades are shown in Fig. 1.1.

Wood weathering research is mainly carried out by forestry or building research institutes. A commonly held attitude among researchers in the field is that weathering and color changes of wooden surfaces is an undesired consequence of exposure to weather, a material weakness and an esthetic problem. Phrases like “discoloration”, “staining” and “degradation without decomposition” are commonly found in literature on wood weathering (Kirk, T.K. and Cowling, E.B. 1984). As a consequence of this perception, efforts to prevent or reduce the effects of weathering are research priorities.

However, rather than an undesirable consequence of weather exposure, color changes of wooden surfaces may be regarded as an interesting and unexploited architectural potential by using weather to produce desired weathering colors on untreated wooden façades. This approach to wood weathering is fundamentally different from the rationale that guides many of today’s research activities and offers a new branch within the field of wood weathering research that is highly relevant in contemporary architectural design. Untreated wood as façade material has become a high profiled material worldwide in rural as well as in urban locations. Environmental concerns, awareness of renewable resources, low maintenance costs and an appreciation for the esthetics of the naturally weathered wooden surfaces are some of the factors that have made untreated wood an attractive choice and an alternative to chemically modified and painted wood.

Literature on and recommendations for designing with untreated wood as façade material predominantly provides information on matters regarding material durability.

Technical aspects of material properties and performance are always important in architectural design, but cannot stand alone. In the case of untreated wooden claddings

the short and longer term color settings of the façade are vital and integral parts of the architectural design. Information on weathering colors and color patterns to be expected from a particular design is scarce due to limited research on the matter. Present day information on color development of untreated wooden façades is mainly concerned with recommendations on how to achieve a mono color grey weathered appearance of the wooden surface. However the wood weathering color register, and the options for creating unique and naturally developed color patterns of a wooden cladding through the interactions of design and local weather, is enormous and has been largely left unexplored.

The purpose of this study is to gain more knowledge on weathering colors of untreated wooden façades with particular focus on the color development of the cladding part of the façade. In this study the cladding is considered an individual building element that can be detached from the façade and studied separately. The wooden cladding can be compared to a piece of fabric sold by the meter for design of clothing.

More knowledge on weathering of untreated wooden claddings can be used as an active parameter in architectural design to create wooden façades that develop unique color settings according to the cladding design and the local weather conditions.

1.1 Problem statement

When exposed to weather, untreated wooden claddings develop colors naturally as a result of the interplay between the wood surface, the cladding design and the actual weather exposure. There are unlimited options for designing claddings with untreated wood but only a small number of cladding types, and their subsequent weathering color development has been studied, documented and described.

Equipped with more comprehensive knowledge of the weathering color development of different types of cladding design, the architect would benefit from having more options of choosing a cladding design where the future anticipated weathering color development is known. Knowledge on the future weathering of the cladding allows the architect to incorporate the color scheme into the overall architectural concept of the façade and the building.

1.2 Research objectives

In order to address the problem statement, the overall goal of this research is to understand more about weathering color development of different cladding designs with untreated wood. This goal is addressed through the following research objectives:

Objective 1: Design an experiment where a number of untreated wooden claddings with different geometries weather under different types of natural weather conditions.

Objective 2: Document and present the results in a way that allows the reader the possibility to independently evaluate the weathering color development in a manner that closely resembles real life experience.

Objective 3: Analyze the relationship between cladding design, weather exposure and weathering color development.

Objective 4: Develop climate visualization tools for supporting the analysis of the color development of the claddings in the experiment.

The aim of this study is to establish a territory within the wood weathering research field which focuses on the esthetic values of natural wood weathering in a way that is relevant to the architectural profession. Figure 1.2 shows an overview of the wood weathering research field, the scope and limitations of this work.



Figure 1.1 Examples of weathered untreated wooden façades. 1: Stovewood barn. Ner Skjørtad, Oppdal, Norway. Construction year around 1840. Photo taken 2004. 2 and 3: Villa Kittilsen, Ålesund, Norway. Architects: Jensen and Skodvin. Construction year 1997. Fotos taken 2007. 4: Hamar town hall, Hamar, Norway. Architects: Snøhetta. Construction year 2000. Photo taken 2007.

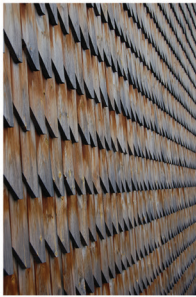

5

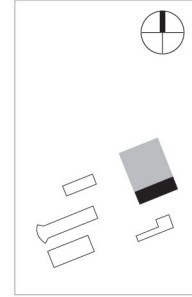

6

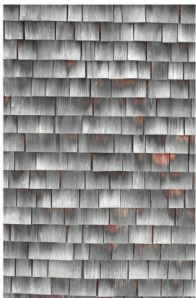
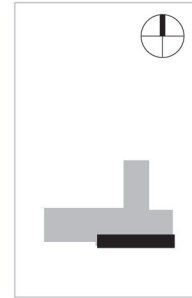

7

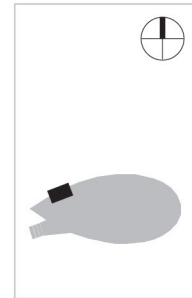

8

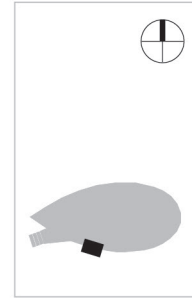

5 and 6: Rena military camp, Rena, Norway. LPO Architects. Construction year 2004. Photos taken 2008. 7 and 8: Saint Benedict Chapel, Sumvitg, Graubünden, Switzerland. Architect: Peter Zumthor. Construction year 1988. Photo taken 2011. All photos © Majbrit Hirche.

CHAPTER 1: INTRODUCTION

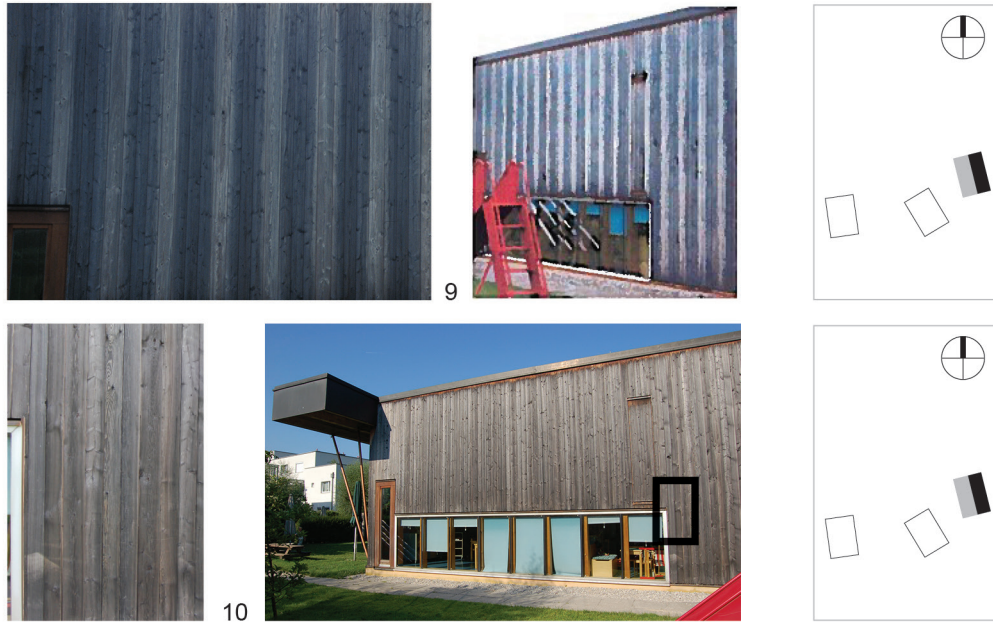

Figure 1.1 continued Aigen Kindergarten, Salzburg, Austria. Architect: Max Rieder. Construction year 1998. 9: Left foto © Helge Solberg 2003. Right foto from SINTEF Byggforsk 2008. 10: Photos taken in 2008 after 10 years of weather exposure. Photo © Majbrit Hirche.

THE USE OF UNTREATED WOOD IN OUTDOOR APPLICATIONS

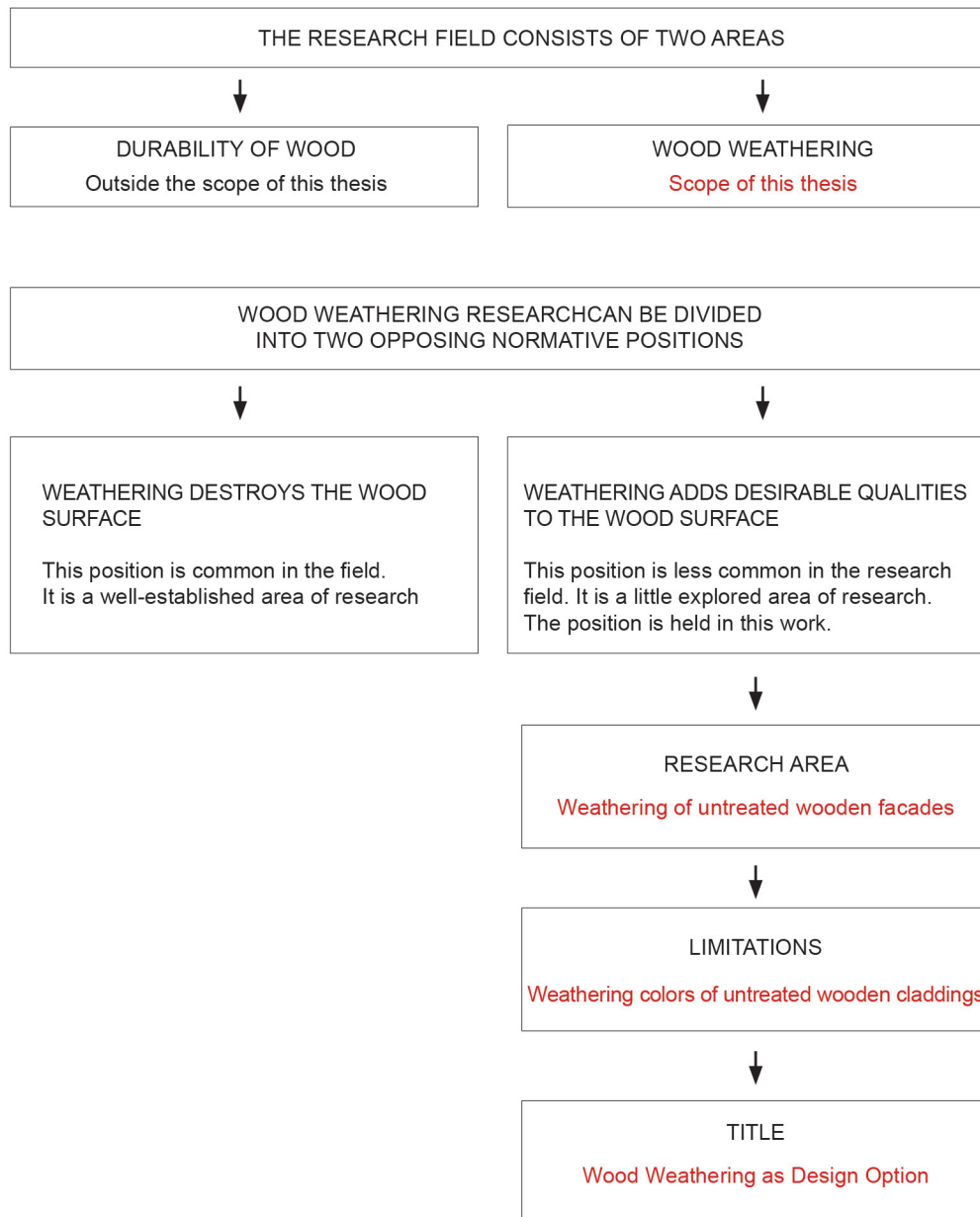

Figure 1.2 Schematic overview of the research field and the scope of this work.

CHAPTER 2: CURRENT STATE OF THE RESEARCH FIELD

2 Current state of the research field

Weathering of wooden claddings is a context-dependent phenomenon, where elements typically present as part of a building façade and the environment plays a role in the way the wooden cladding develops its color and color patterns. The current state of knowledge on weathering of wooden claddings can be divided into knowledge on a) the processes that causes the color changes of the wooden surface, and b) factors in building design and the surroundings that influence the weathering color processes. Whereas weathering processes independent of influence from any building context is a well-established field of research, wood weathering in the context of building design is less studied.

Literature on the weathering of wooden claddings and façades is mainly published by building research institutes in the form of recommendations to the building sector. Knowledge is based on experience from weathered wooden façades rather than based on research, hence no peer-reviewed scientific articles are readily available on the topic. Building design is by definition a contextual discipline, and knowledge on weathering is typically communicated in the form of rules of thumb that discuss matters in a general way. The majority of references used in this presentation of the current state of research in the field relate to review literature on wood weathering processes and publications from building research institutes in Norway on weathering related to the context of a building.

In order to establish a structured overview on the topic, current knowledge on the matter is grouped into categories defined by different scales in a building context. First there is a presentation of weathering of the wooden surface independent of any influence from a building context, followed by knowledge on weathering of wooden claddings. Aspects of weathering related to elements typically present in a building façade and building envelope are presented separately, and finally there is a presentation of elements in the environment known to affect the weathering color development of the cladding.

2.1 Weathering of the wooden surface independent of a building context

The wooden surface independent of any building context that may influence the exposure pattern and the color development has the potential for developing either mono color grey or brown.

Grey weathering color is produced by micro fungal growth in the outer- most wood cell layers of the wooden surface (Zabel, R.A. and Morrell, J.J. 1992). These fungi are commonly referred to as dark walled fungi due to the black color pigment, melanin, present in the fungal hyphae. A wooden surface colonized by dark walled fungi appear grey to the human eye. The most common species among the dark walled fungi are the *Aureobasidium pullulans* (Eaton, R.A. and Hale, M.D.C. 1993). Growth requirements for the dark walled fungi are nutrients in the form of sugars, oxygen in cell lumen, the absence of toxic substances such as extractives, temperature between 15–45 °C (optimal), moisture content above the fiber saturation point (FSP) and duration of time (Zabel, R.A. and Morrell, J.J. 1992). The fungal spores are airborne and omnipresent globally. In the event of precipitation, typically in the form of rain, the wooden surface is wetted and the moisture content in the outer-most cells rises to favorable levels for fungal growth. Once the dark walled fungi have become established on the wooden surface, growth will occur when conditions are favorable, and slow down or pause when conditions are unfavorable for growth, for instance when the moisture content drops below the FSP or temperatures are too low.

The value of wood as a substrate for dark walled fungal growth varies significantly between different wood species and tissue quality. As a rule of thumb, heartwood has lower nutritional value compared to sapwood due to the presence of toxic extractives in the heartwood. This result in a significantly lower rate of fungal growth on heartwood compared to sapwood (Zabel, R.A. and Morrell, J.J. 1992).

High density wood provides a poorer substrate compared to low density wood. All other variables being equal, high density wood requires more water to reach moisture levels above the FSP compared to low density wood (Kollmann, F.F.P. and Côté, W.A. jr. 1968). This allows for faster establishment and growth of dark walled fungi on low density compared to high density material.

Dark walled fungi must not be confused with wood-decaying fungi. Whereas the dark walled fungi live on sugars in the wood cell lumen and spread the mycelia web via the pits in the wood cells, wood-decaying fungi derive nourishment from the cell wall constituents and extend the hyphae through the cell walls. Whereas the dark walled fungi are considered harmless to the substrate material, the presence of wood-decaying fungi results in material destruction (Eaton, R.A. and Hale, M.D.C. 1993). The ensuing grey color development is often referred to as biological weathering due to the biological nature of this type of weathering process.

Brown weathering color development of the wooden surface occurs when the surface is exposed to solar radiation. The wood cell wall constituents; cellulose, hemicelluloses and lignin, have different chemical reactions at different wavelengths. The principal brown color generating processes are divided into a) non-degrading oxidative processes caused by light and b) lignin-degrading processes caused by UV radiation (Feist, W.C. and Hon, D.N.-S 1984).

The non-degrading process occurs when the wood surface is exposed to daylight at wavelengths ranging from 400–3000nm, causing the cellulose and hemicelluloses part of the cell wall matrix to brown (Williams, R.S. 2005). The lignin-degrading process

occurs when the wooden surface is exposed to UV radiation at wavelengths of 295-400nm. In this case, the UV radiation causes the lignin molecule to break down, resulting in the formation of brown chromophores (Feist, W.C. and Hon, D.N.-S. 1984). In the lignin-degradation process, the lignin molecule is detached from the cell wall matrix and the loosely attached waste products accumulate on the wooden surface. In the event of repeated exposure to UV radiation, the degradation waste products continue to accumulate on the wooden surface. In the event of exposure to a combination of UV radiation and precipitation, the loosely attached lignin degradation waste products are removed from the surface (Williams, R.S. 2005). This process is often referred to as “washing out”. The result of repeated cycles of lignin degradation and the subsequent washing out is that lignin is removed from the wood surface. This process results in higher concentrations of cellulose on the wood surface, since lignin is removed from the cell wall matrix (Feist, W.C. and Hon, D.N.-S 1984). In some instances the cellulose strands are visible to the human eye as tiny threads emerging from wood surface. This phenomenon is sometimes referred to as a “cellulose matt”. The process of lignin degradation, in combination with precipitation and washing out, results in a slow erosion of the wood surface. As a rule of thumb, the erosion rate is 5-7 mm per 100 years (Feist, W.C. and Hon, D.N.-S 1984). The erosion rate for low density wood is higher compared to high density wood (Williams, R.S. 2005). In addition, as a result of the presence of water in the process of washing out, dark walled fungi become established on the wood surface.

Solar-induced brown color development is often referred to as chemical weathering due to the chemical nature of the processes that occur at wooden surface. The processes are also referred to as photochemical or photo oxidative-processes.

2.2 Weathering of wooden claddings

Once the wooden surface is part of a cladding, it is also part of a physical environment that may influence the weather exposure pattern and consequently how weathering colors develop on the surface.

Literature describes two principal types of claddings and related weathering color development: a) the plane, shade-free type of cladding and b) the non-plane, shade-generating type of cladding (Larsen, K.E. and Mattsson, J. 2009).

Weathering colors related to plane cladding types are mono color grey or brown. Mono color weathering is made possible due to the geometry of this type of cladding, which allows for a uniform distribution of weather effects across the entire surface area (Larsen, K.E. and Mattsson, J. 2009). The grey color option occurs when the cladding is exposed to precipitation alone or in combination with solar radiation. Precipitation activates the biological weathering processes. The brown color option occurs when the plane cladding is exposed to solar radiation which activates chemical processes in the wooden surface. Details of these weathering processes are described above.

Literature on weathering color of non-plane types of claddings and the related color development is limited. The three-dimensional structure of the geometry of non-plane

types of cladding generates elements that create varying degrees of shade on the surfaces, resulting in uneven distribution of weather across the surface (Larsen, K.E. and Mattsson, J. 2009). What little available literature there is on the subject contains no clear description of non-plane type of claddings and related weathering color development. In a text accompanying a photo of a weathered clinker type of cladding the color pattern is described as uneven (Larsen, K.E. and Mattsson, J. 2009).

According to literature, an uneven distribution of weather results in uneven color development. Although literature is not specific on the matter, it seems that the term “uneven” describes a color development that involves grey and extractive deposits. Extractive is the general term for soluble wood substances, of which some are soluble in water (Kollmann, F.F.P. and Côté, W.A. jr. 1968). Wetting of wood may cause water soluble extractives to dissolve, migrate and deposit on the wood surface upon drying. This is often referred to as extractive stains or simply discolor.

Fasteners and joints may be part of the design of both plane and non-plane cladding types and influences the color development locally. If fasteners like screws and nails protrude from the vertical wood surface, they may serve as small water collecting trays that lead water onto the surface below the fastening device. This causes elevated levels of moisture locally, potentially resulting in faster growth of dark walled fungi in areas below fasteners. Fasteners may also be placed deep in the material, in which case the wood surface is crushed and end grain may come in direct contact with water. Exposure to water in end grain regions causes elevated moisture levels locally due to capillary actions, resulting in faster local growth of dark walled fungi. Corrosive stains from metal fasteners may color the wooden surface locally. Butt joints or similar types may be used to extend the length of wooden boards in a cladding. Joints represent two end grain surfaces that potentially come in direct contact with water. The capillary actions in the end grain results in elevated levels of moisture, resulting in fast growth of dark walled fungi locally (SINTEF Byggforsk 2008, Brandstätter, M. 2002).

2.3 Weathering color development related to elements in the building façade and the building envelope

Once the cladding is placed in the context of a façade, the cladding is likely to be influenced by the physical environment of that particular façade. Elements that are typically part of a building façade, such as window sills, door canopies and roof hang, may influence the weather exposure patterns resulting in local color development of the cladding that differs from that in other areas of the cladding. It may be that by creating shade on parts of the cladding that prevents exposure to precipitation and/or radiation, or by directing additional water onto areas of the cladding, more or less favorable fungal growth conditions can be created locally compared to other parts of the cladding. Any adaptation on the façade, such as electrical installations or other elements that interfere with the distribution of weather on the cladding has the potential to influence the color development of the wooden surface (SINTEF Byggforsk 2008).

Thermal bridges may also affect the color development of the wooden surface.

Higher or lower temperatures on the wooden surface caused by the interior structures may affect the local growth conditions for dark walled fungi on the cladding (Gobakken, L.R., Mattsson, J. and Alfredsen, G. 2008).

The lowermost part of a wooden cladding is typically exposed to higher amounts of water, causing more favorable conditions for dark walled fungi compared to the remnant part of the façade cladding. These varied conditions in moisture content result in a darker grey area of the cladding closest to the ground. Splash from the ground and capillary suction in the end grain area of vertically mounted boards are factors that raise the moisture content in the lower-most part of a wooden cladding (SINTEF Byggforsk 2008).

A façade is a part of the whole building envelope that may consist of several façades facing in entirely different directions. Precipitation in the form of wind-driven rain, as well as solar radiation, comes from different directions and in different amounts. Identical claddings on a building envelope facing in different directions are typically exposed to different weather conditions and may develop different weathering color pattern. A clinker type of cladding may develop a color pattern of grey on the lower and extractive deposits on the upper part of the boards, and exposure to wind-driven rain may increase the area of grey and reduce the area of extractives. North facing façades are attributed to grey color development. South facing façades are attributed to first grey color that turns into brown after a period of time (SINTEF Byggforsk 2008).

2.4 Weathering color development related to factors in the near environment

Environmental factors may affect the color development of the wooden cladding. Vegetation close to the building façades may cause changes in the microclimate locally that deviate from that to which other parts of the wooden cladding are exposed to. Bushes and trees in particular may affect the local microclimatic conditions, causing shade that lowers the temperature, resulting in longer Time of Wetness (TOW) of the wooden surface. This favors the growth of dark walled fungi (SINTEF Byggforsk 2008).

CHAPTER 2: CURRENT STATE OF THE RESEARCH FIELD

3 Materials and methods

This chapter is structured in three parts. The first part concerns the development of ideas and concepts on working with weathering of wooden claddings. In the second part, methods to analyze and study weathering are discussed. The third part concerns the development of tools to visualize the main weather elements responsible for color changes on wooden surfaces i.e. wind-driven rain and solar radiation. This part of the work is made in collaboration with Dr. Steen Aagaard Sørensen. The author is responsible for the developing of ideas to visualize weather as well as the graphic design of the weather maps. Dr. Sørensen is responsible for the calculation and modeling of the weather maps.

3.1 Developing a conceptual grasp for working with weathering of wooden claddings

The topic of weathering of untreated wooden claddings is little studied and therefore documented knowledge on the matter is scarce. In order to develop a deeper understanding, a preliminary study was made. The study was carried out by means of constructing small scale sketch models, which served as the basis for generating ideas on way to approach the interactions between cladding design, weather exposure and weathering color development. The ideas were analyzed and further developed into concepts useful for approaching this topic. The method of developing ideas by means of sketch models is commonly used to develop architecture and design and serves the purpose of creating a basis for inspiration and a non-biased approach to a topic.

The exercise was designed and executed as follows: Medium-density fibreboard (MDF) was used to simulate natural wood. The advantage of MDF over natural wood in this type of exercise is that MDF allows for a more abstract approach on the topic due to its neutral and homogeneous visual appearance compared to that of natural wood. An MDF stick with a cross-section of $1 \times 1 \text{ cm}^2$ was used as the proportioning unit. The MDF sticks simulating small scale wooden boards were referred to as the “basic elements”. 5 different basic elements were designed. These were one square, two rectangular, one triangular and one circular. In addition, a few cladding models were made of basic elements made of branches with and without bark and thinly cut natural wood for woven patterns.

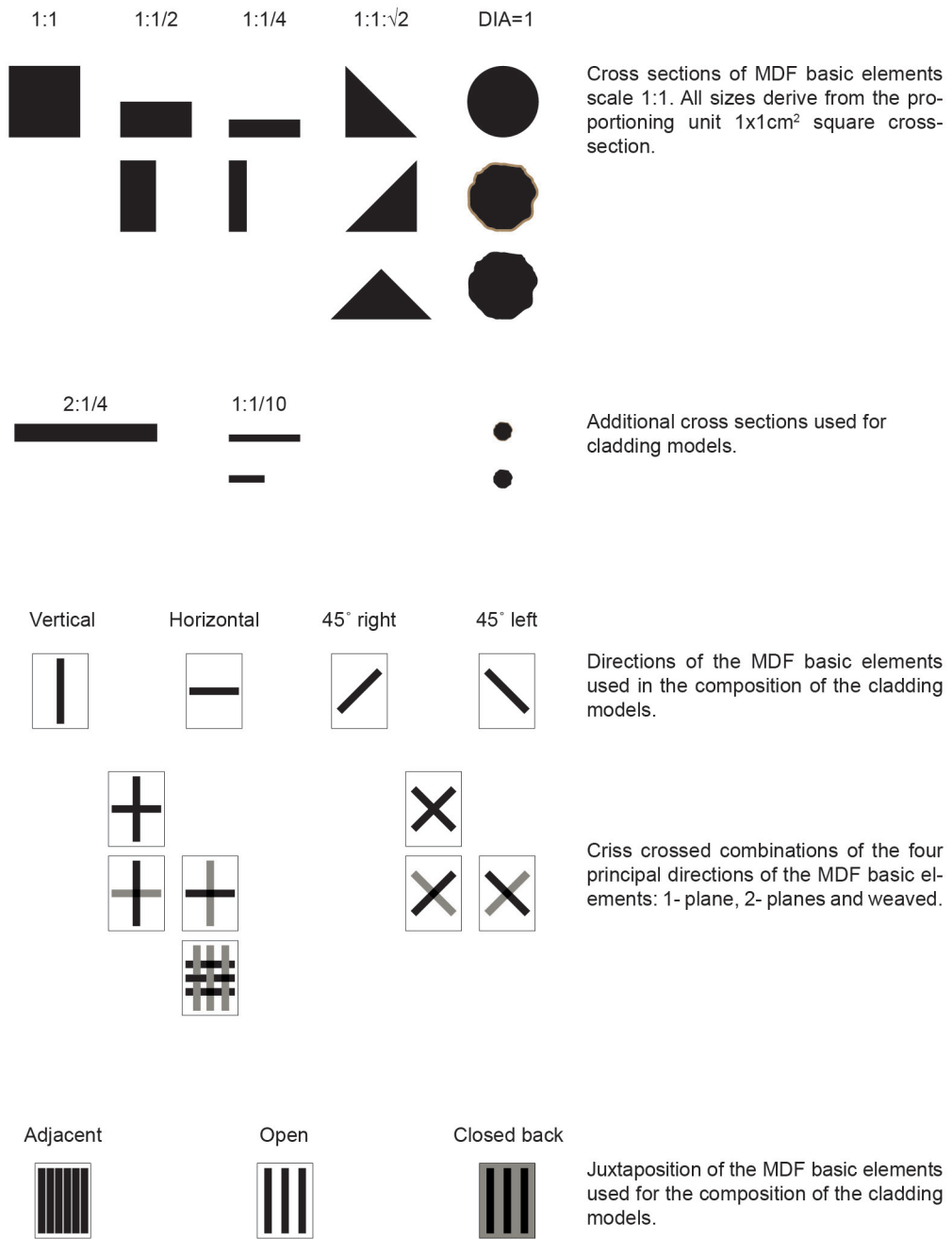

Figure 3.1 Systematics used for creating the small scale MDF study models.

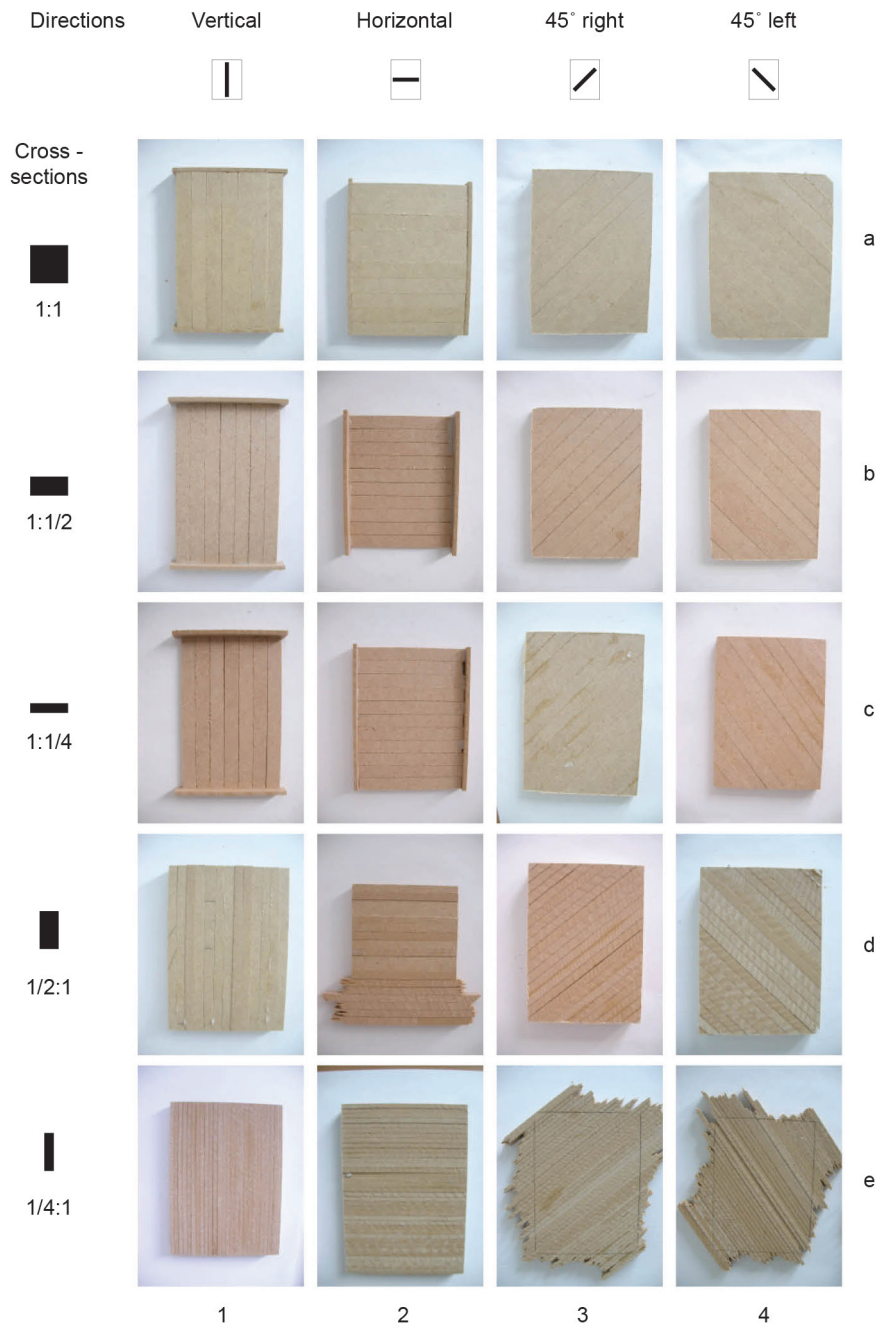

Figure 3.2 MDF study models. Claddings with square (row a) and rectangular (rows b-e) cross-sections in an adjacent composition.

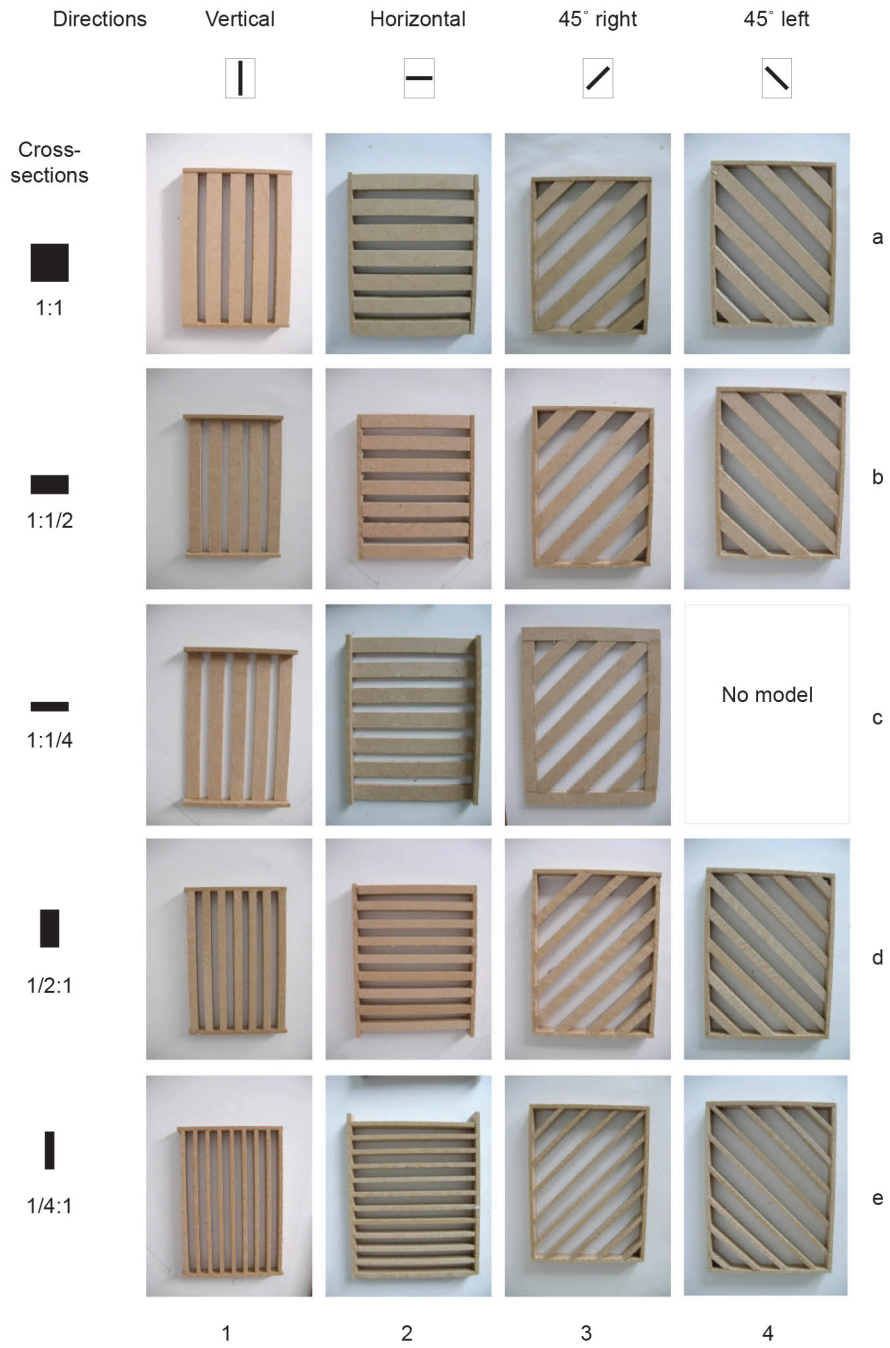

Figure 3.3 MDF study models. Claddings with square (row a) and rectangular (rows b-e) cross-sections in an open composition.

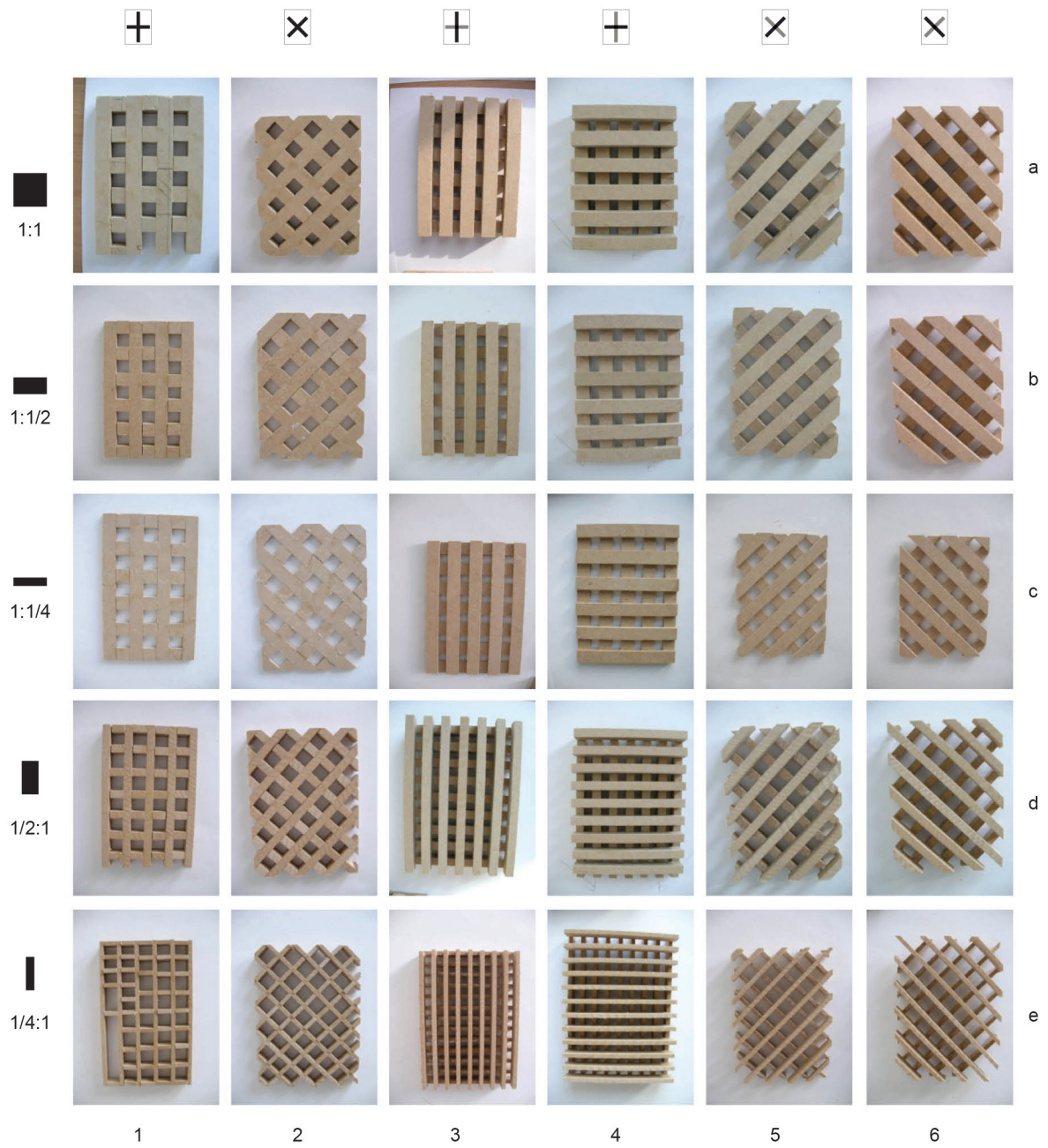

Figure 3.4 MDF study models. Claddings with square (row a) and rectangular (rows b-e) cross-sections in an open composition. Columns 1-2 are composed in one plane, column 3-6 are composed in two planes.

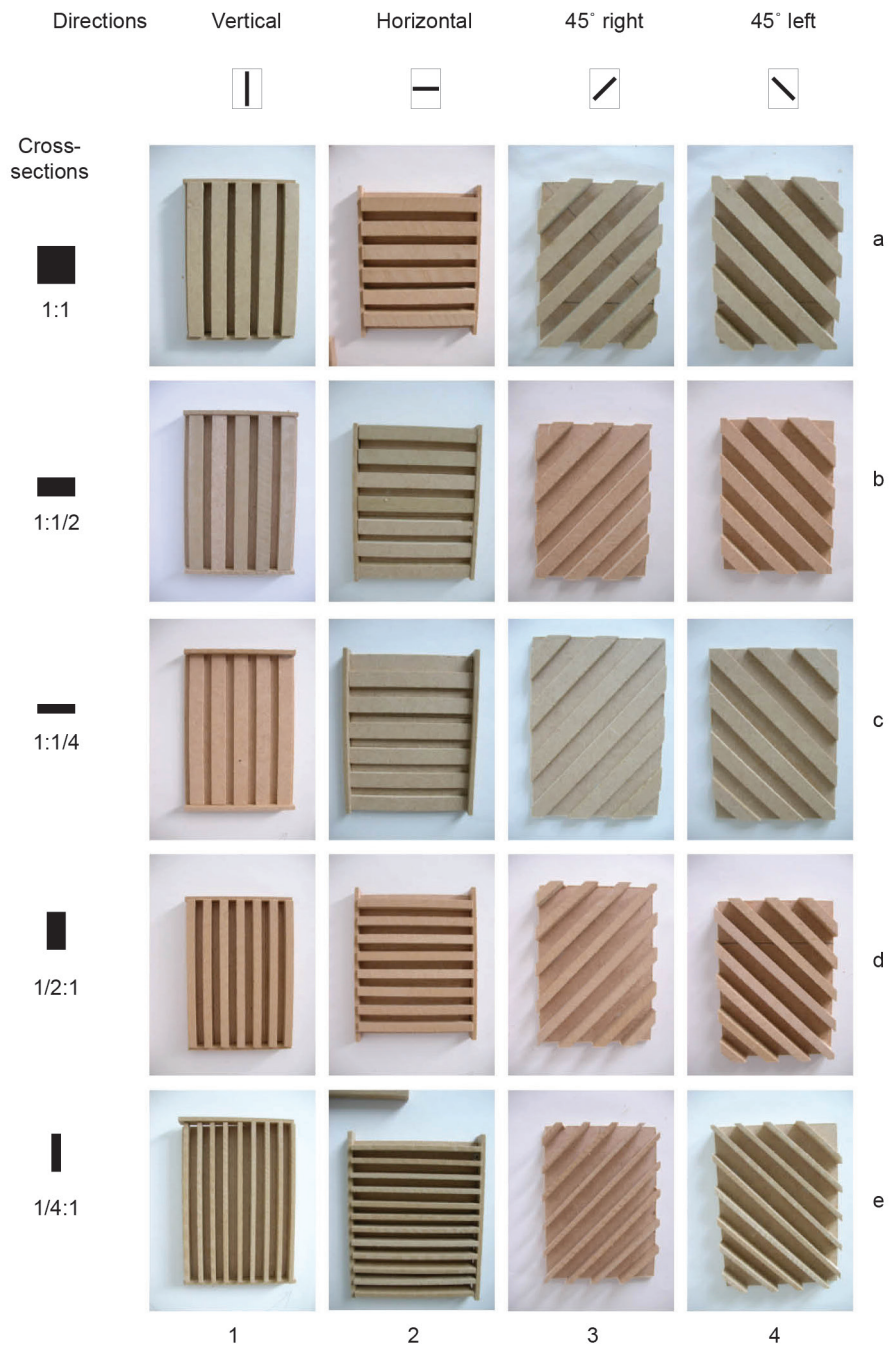

Figure 3.5 MDF study models. Claddings with square (row a) and rectangular (rows b-e) cross-sections in an open composition with a closed back.

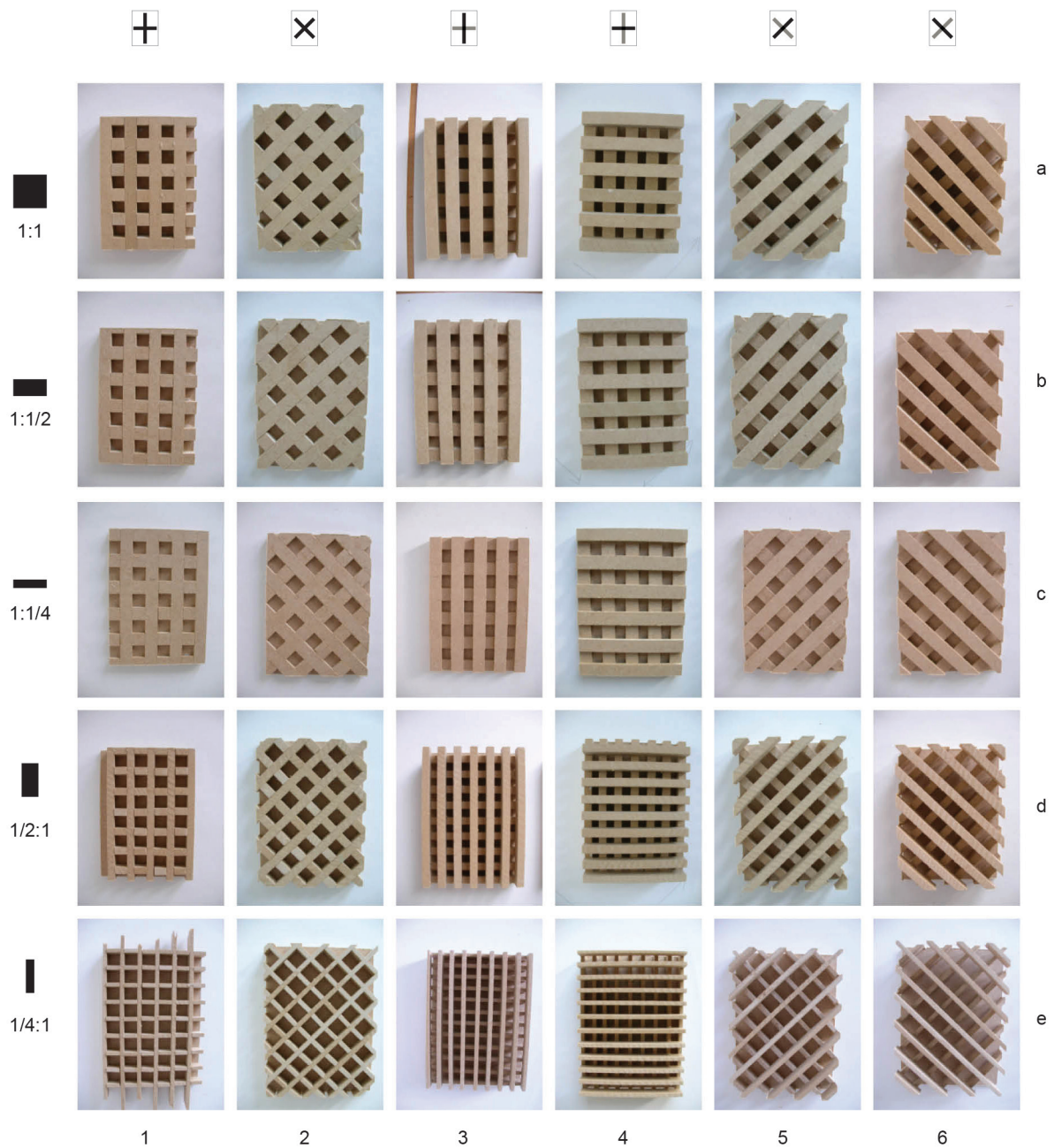
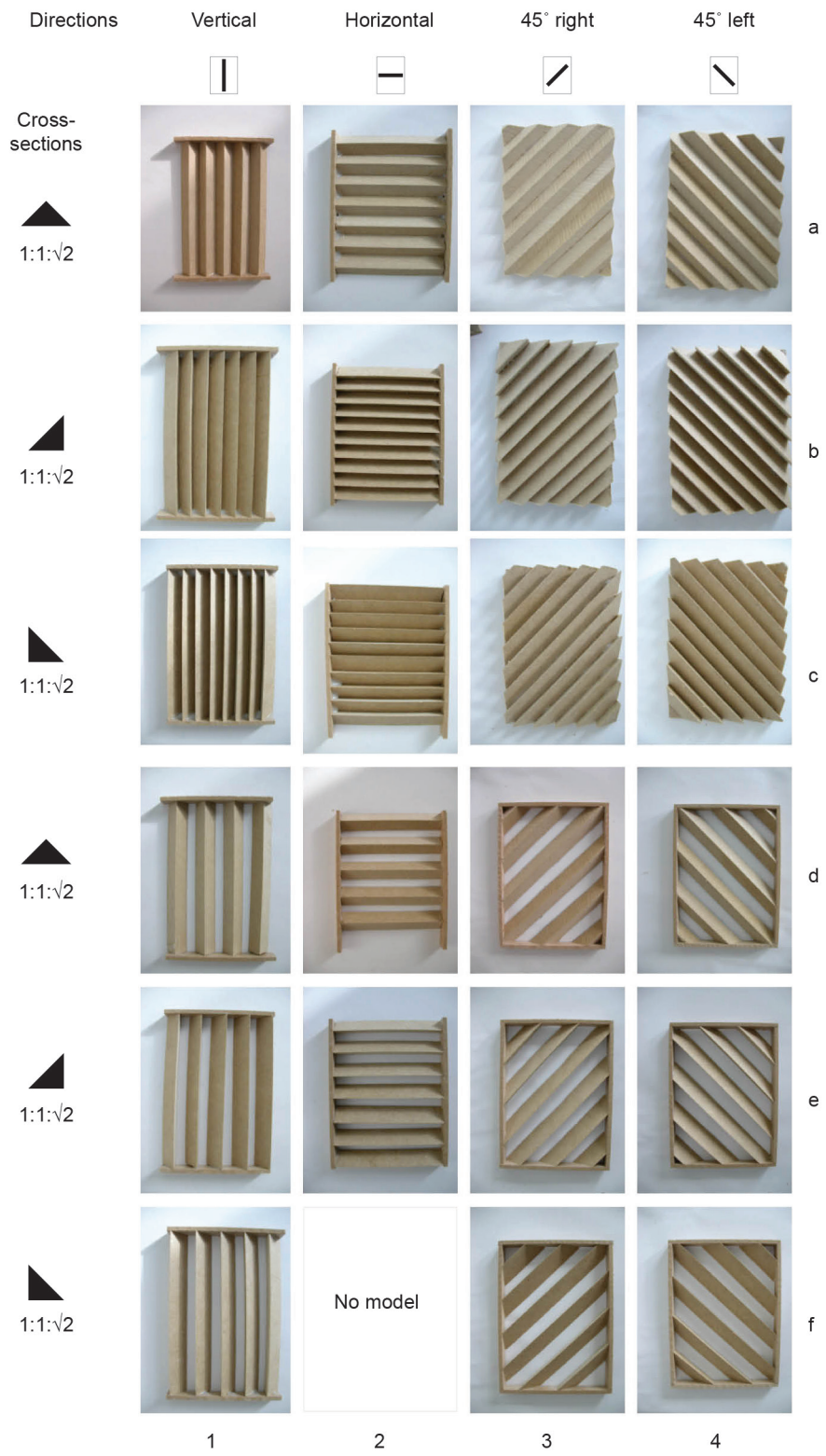

Figure 3.6 MDF study models. Claddings with square (row a) and rectangular (rows b-e) cross-sections in an open composition with a closed back. Column 1-2 are composed in one plane, column 3-6 are composed in two planes.

CHAPTER 3: MATERIALS AND METHODS



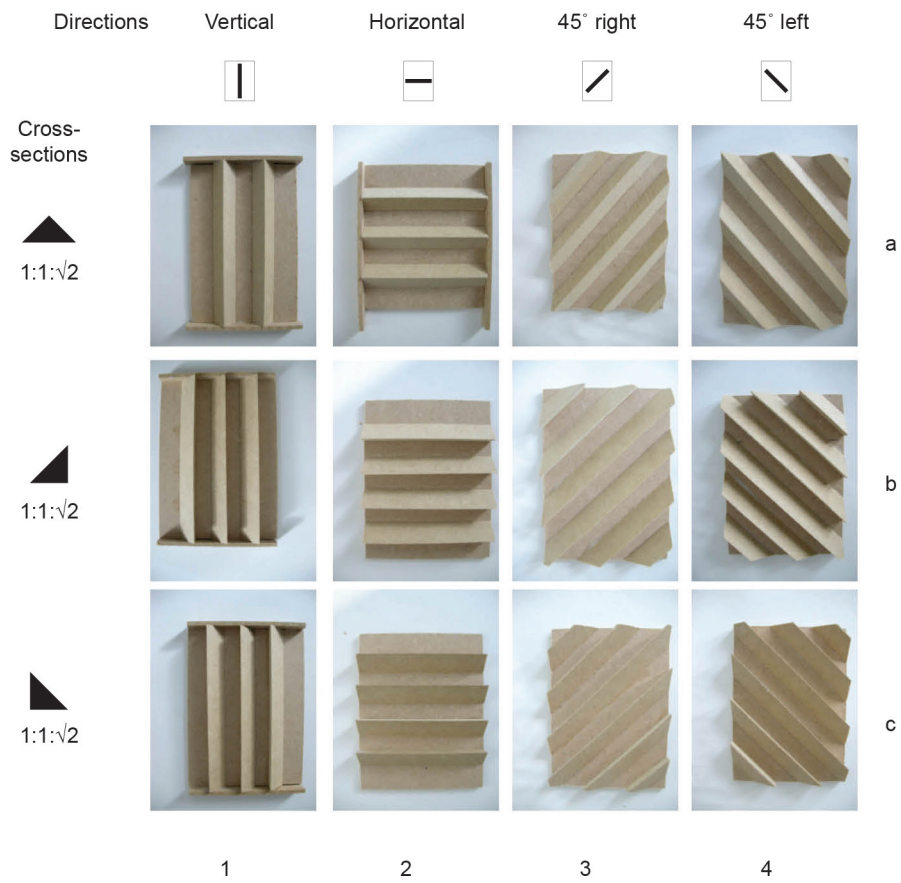

Figure 3.8 Above. MDF study models. Claddings with a triangular cross-section arranged in an open composition with a closed back.

Figure 3.7 Left. MDF study models. Claddings with a triangular cross-section arranged in an adjacent composition (rows a-c) and open composition (rows d-f).

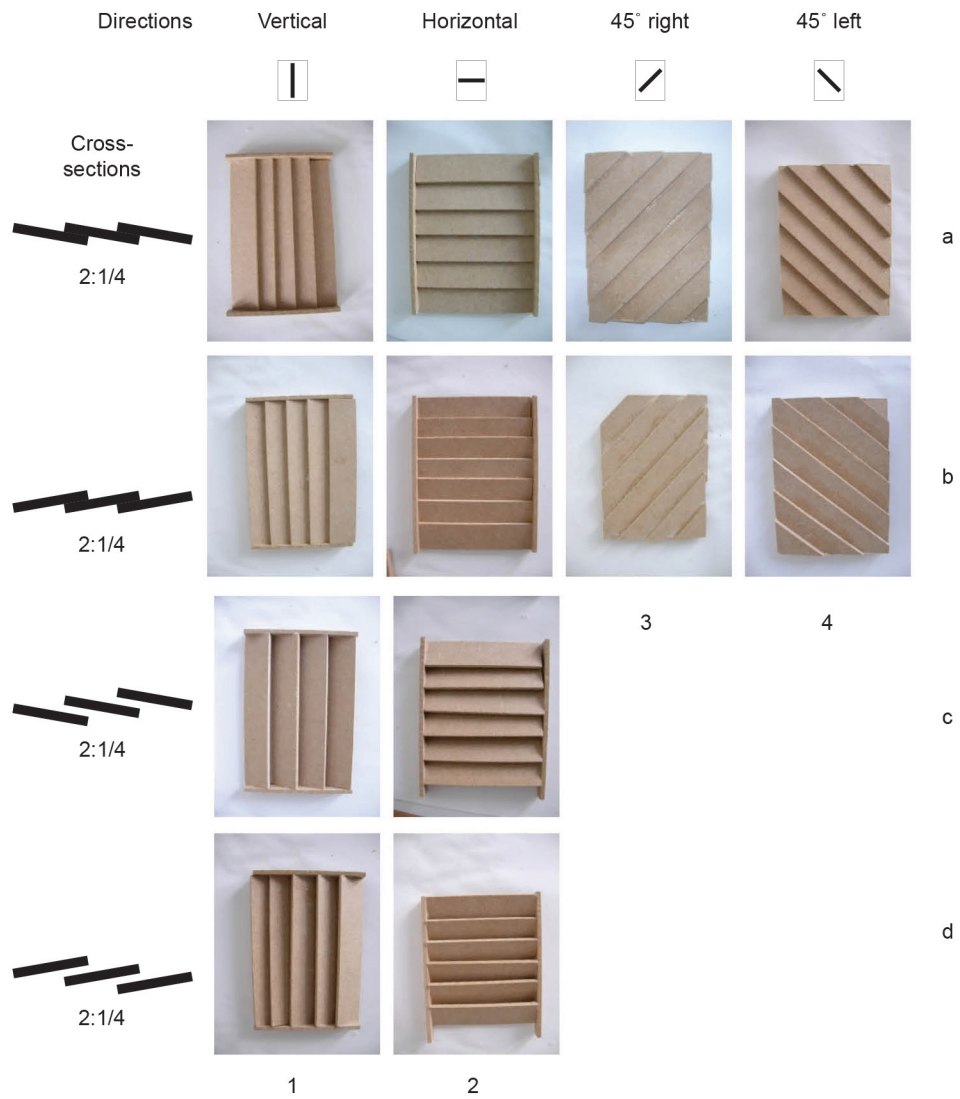

Figure 3.9 MDF study models. Claddings with rectangular cross-sections arranged in a closed, overlapping composition (rows a-b) and in an open, overlapping composition (rows c-d).

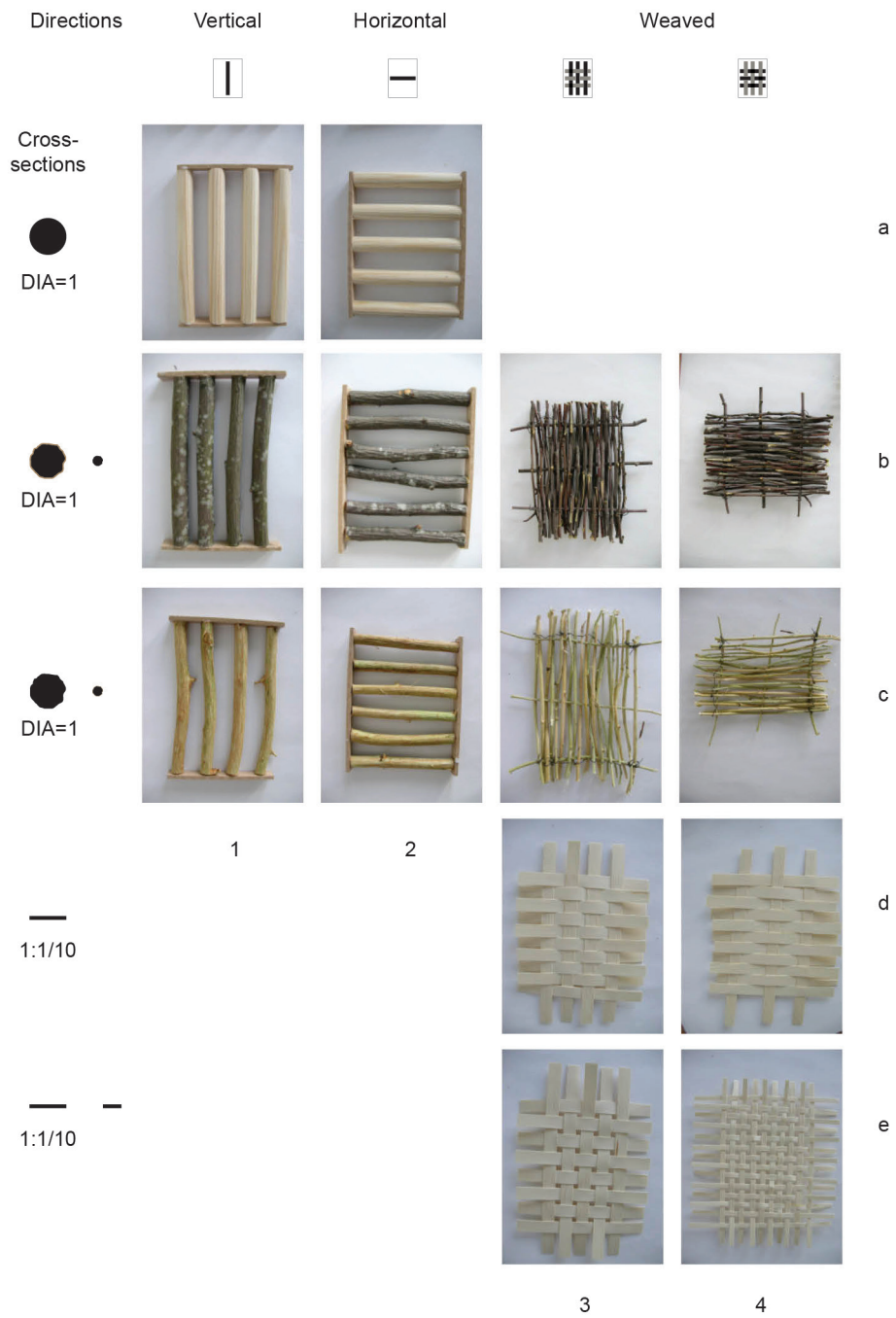

Figure 3.10 MDF study models. Claddings with round cross-sections (rows a-c). Column 1-2 are arranged in an open juxtaposition. Column 3-4 are weaved.

The basic elements were affixed to small-scale cladding models according to the following principles: the basic elements were to be arranged in one adjacent and one open type of juxtaposition. In the adjacent arrangement, the MDF sticks were mounted in a close side-by-side juxtaposition, in the open composition the sticks were mounted apart leaving open space between the individual boards. A third option was defined as the work progressed and referred to as open juxtaposition with a closed back. The intention of this third compositional principle was to include claddings like board and batten that have an open structure on a closed back. The rectangular and triangular basic elements were rotated along the vertical and horizontal axis respectively for more variation in the design. Four different mounting directions of the basic elements were defined: vertical, horizontal, and inclined 45° to the left and 45° to the right. The four directions were additionally combined in a crisscross pattern. In total a pool of 181 models were constructed. The models measured approximately 8 x 12cm² (W x H). Fig. 3.1 shows the systematics used for the exercise. Figs. 3.2-3.10 show the MDF models.

The cladding models were studied and gave inspiration to new terms, ideas and concepts on how to approach the topic of weathering of untreated claddings. These were organized in four subjects:

- Terms for describing weathering of untreated claddings
- The Weathering Equation
- Options for designing an untreated wooden cladding
- Concepts on the relations between cladding design, weather exposure and weathering colors

The following is a presentation of ideas and concepts.

3.1.1 Terms for describing weathering of untreated claddings

It was clear from the beginning that often used value-laden terms such as *discolor*, *disfigure*, *stain* and *uneven* had to be replaced with an objective vocabulary. As the study of the sketch models progressed and ideas began to surface, it also became clear that more terms were needed in order to describe various aspects related to weathering of wooden claddings. The terms designated for this purpose are listed in Table 3.11, together with definitions of the terms. The terms are organized into three principal groups according to their relation to cladding design, weather exposure and weathering colors. The list is far from complete. This branch of wood weathering research is scarcely developed, and there is plenty of room for inventing new terms and definitions on wood weathering as advances are made in this field.

3.1.2 The Weathering Equation

The principal factors involved in weathering of wooden claddings are the wood material, and the design of the cladding in combination with the actual weather exposure. In addition, time is an important factor, since weathering is a process that evolves over time.

The principal factors can be described in a condensed form as:

WOOD + DESIGN + WEATHER + TIME = WEATHERING

This simplified statement is referred to as The Weathering Equation. The individual factors in the equation are defined as follows: the wood factor covers all types of wood species and wood tissue. The design factor covers all imaginable cladding designs. The weather factor covers weather elements responsible for the color change of the wooden surface. The principal weather factors are precipitation and solar radiation alone or in combination, as discussed in Chapter 2. Implicit in the weather factor is the omnipresent airborne fungal spores responsible for the grey weathering color, also discussed in Chapter 2. The time factor is defined as the duration of the weather exposure from one point in time, for instance the beginning of the weather exposure, to any given point in time at which the weathering colors are documented.

The outcome of the weather exposure is weathering. Weathering is the general term covering all non-degrading processes on wooden surfaces. The principal weathering colors are grey and brown color nuances as well as various nuances of brown extractive deposits. Each of the elements in the weathering equation has multiple sub-elements.

3.1.3 Options for designing an untreated wooden cladding

There are countless ways of designing a wooden cladding: variations in wood species, tissue, surface quality and dimensions of the material are limitless, as are the number of possible ways in which to compose the cladding. The following basic statement frames the principal elements that are present in any cladding design: a wooden cladding is made of wood that is processed in a certain way, composed into a pattern and fastened. With this basic statement it is possible to point out four overall categories:

WOOD + PROCESSING + COMPOSITION + FASTENING

The four categories can be perceived as processes in a production line where the processes of selecting and processing the wood constitute the first part of the process, compose and fasten the processed wood element constitute the latter part of constructing a wooden cladding. The term “basic element” now describes the individual elements which are the outcome of the processing of the raw wood material. The basic element can for example be a board, a shingle or a rafter. The actual composition of a wooden cladding can be described as the way the basic elements are composed into a pattern.

The following is a description of the four overall categories and the sub-groups. The content in the sub-categories is far from comprehensive, since it is not possible to account for all options. Rather the intention is to construct a framework that demonstrates the innumerable options available for the design of wooden claddings. The framework can be used as a tool for identifying the elements in any given wooden cladding and to serve as inspiration for designing a cladding. A table of the framework is shown in Fig. 3.12.

Terms related to weather exposure	
Term	Explanation
Exposure potential	The term is used in the analysis of the weathering color options of a specific cladding.
Uniform exposure potential	The term describes a situation where a cladding or a surface has the potential of a uniform weather access to the total surface area. Uniform replaces the commonly used term “even” exposure.
Differentiated exposure potential	The term describes a situation where the whole cladding or the individual surfaces have differentiated exposure due to the geometry of the cladding. The differentiated exposure is found in relief types of claddings.
Direct weather exposure	Describes an exposure situation where the surface is exposed to precipitation or solar radiation directly.
Indirect weather exposure	Describes a situation where the surface is indirectly exposed to precipitation or solar radiation for instance in the form of dripping rain, splash or run off water.
In-situ weather conditions	The term refers to the specific weather conditions at a given site.

Terms related to weathering colors	
Term	Explanation
Weathering color potential	The term is used in the analysis of the weathering color options of a specific cladding or surface.
Uniform weathering color potential	Describes a situation where the weather has uniform access to the whole cladding or to some of the surfaces in a cladding resulting in a mono color type of weathering of the cladding or of individual boards in a cladding.
Differentiated weathering color potential	Describes a situation where weather has differentiated access to the surfaces of a cladding.
Weathering color pattern	Term used in the description of a weathered cladding.
Pattern repeat	Term borrowed from textile design. The term describes the smallest unit of the sequence of color in a weathered cladding.
Mono color weathering	Same color of the cladding or the surface i.e. grey or brown.
Multi color weathering	Color variations of the cladding and/or of the surfaces.
Weathering grey	The characteristic grey color of the wooden surface developed through the actions of precipitation alone or in combination with solar radiation.
Grey color fungi, dark walled fungi	General terms for all wood inhibiting and non-degrading fungi that cause the wooden surface to appear grey due to the black color pigment, melanin, contained in the fungal hyphae.
End grain grey	The term describes the specific grey color development close to end grain caused by capillary actions. Typically found on the lower part of vertical cladding closest to the ground and in connection with wood joints.
Oxidation brown	The term describes the color brown associated to the chemical processes induced by solar radiation that causes the wooden surface to develop brown color.
Extractive brown	The term describes the brown color associated to extractives that have migrated and deposited on the wooden surface.
Extractive deposits	The term replace the commonly used “extractive stains” that is a value-laden term.

Terms related to wooden cladding design	
Term	Explanation
Plane cladding geometry	Plane type of claddings have a 2-dimensional geometry. This geometry does not produce shade. Plane type of claddings are associated to mono color weathering due to the absence of protruding elements which allows for a uniform weather exposure. Plane types of cladding may also be referred to as one-face type of cladding.
Relief cladding geometry	Relief type of claddings have a 3-dimensional geometry. This geometry produces shade. Relief type of claddings are associated to multi color development due to protruding elements which allows for a differentiated weather exposure. Relief types of cladding may also be referred to as multi-face cladding.
Open structure	Open type of claddings have a non-adjacent juxtaposition of the basic elements and clearly visible air gaps between the basic elements. The open types of claddings are typically used in front of windows where the construction side is visible from the inside of the building.
Closed structure	Closed type of claddings have adjacent juxtapositions and small or no air gaps between the basic elements. Typically the closed structure claddings are only visible from the weather side of the cladding as opposed to the open structure claddings.
Weather accessibility	The term weather access is used to describe a relation between the cladding geometry and weather exposure.
Uniform weather access	Uniform weather access describes a situation where the cladding geometry allows for theoretically uniform weather access of the total surface area. This condition applies to plane type of claddings.
Differentiated weather access	Differentiated weather access describes a situation where the cladding geometry allows for differentiated weather access of the surface area. This condition applies to relief type of claddings.
Weather side	Weather side refers to the side of a wooden cladding that faces weather directly. The term is used synonymously with front of a cladding.
Construction side	Construction side refers to the side of a wooden cladding that is turned away from direct weather exposure. The term is used synonymously with back of a cladding.
One or two sided visibility	This expression is used to define if a cladding is to be viewed from one or two sides i.e. from weather side only or from weather- and construction side.
Shade pattern	The term refers to the pattern of shades produced by the cladding geometry. The term can be applied to the whole cladding or the individual surfaces in a cladding.

Figure 3.11 Terms for describing weathering of untreated claddings.

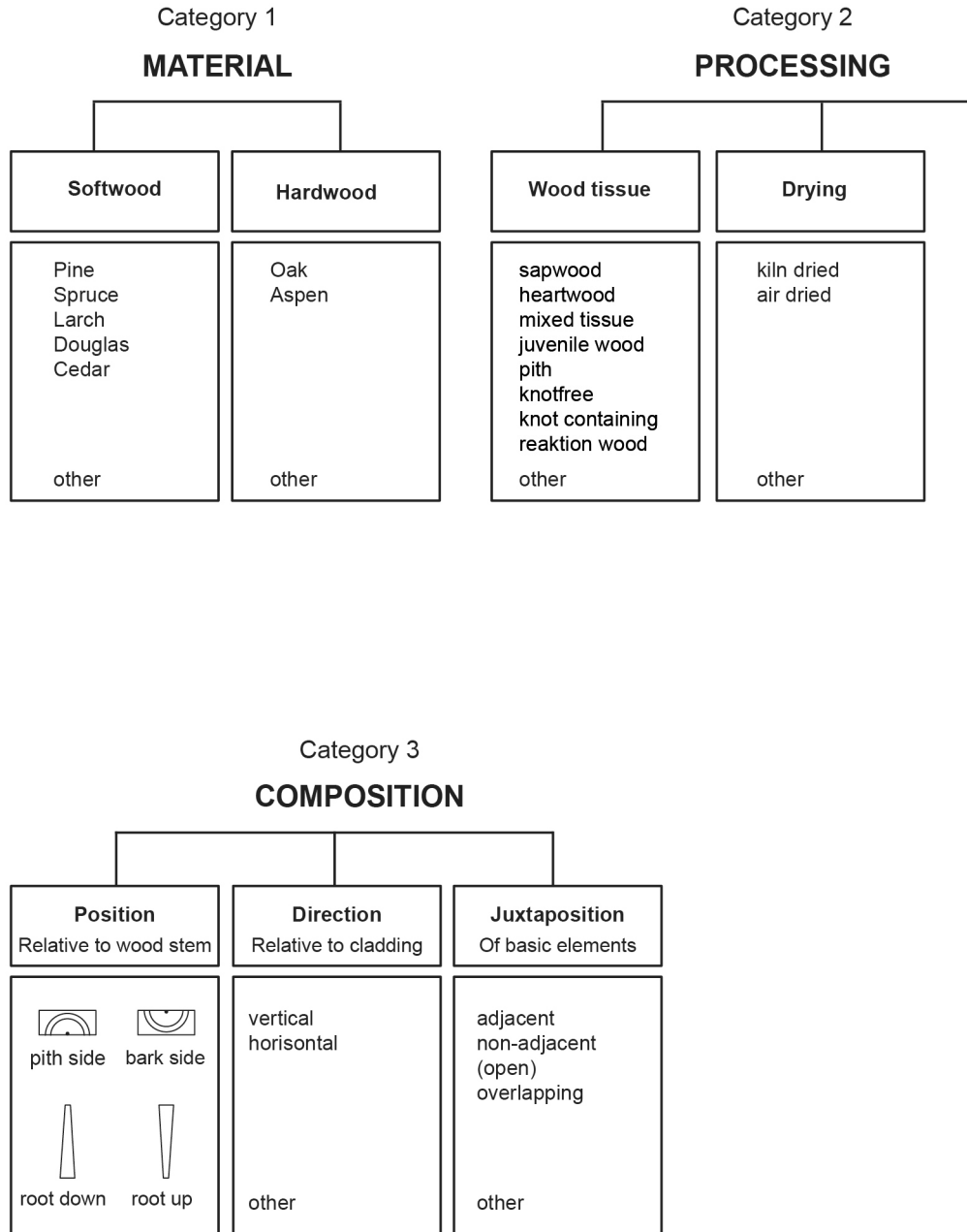

Figure 3.12 A framework showing the principal options for designing a wooden cladding.

Category 2

PROCESSING continued

Cutting pattern	Shape and dimension	Surface character	Joining
radial sawn tangential sawn other	unlimited shapes and dimensions e.g. rectangular square triangular rounded profile board other	sawn planed split ax cut with bark charred surface other	finger- scarf- butt joints other

Category 4

FASTENING

Visible	Invisible
nails screws wood nail lashing other	nails screws wood nail lashing other

Category 1 and 2 constitute the first part of a production process where the basic elements for the construction of a cladding are designed.

Category 3 and 4 constitute the latter part of the process where the basic elements are assembled to a cladding.

The term "other" indicates that there are many more options than listed in this framework.

Category 1: Wood. The first category defines a starting point: the raw material in its basic form, which is the tree prior to any processing of the material. This category contains all wood species in the world. The category is sub-grouped into hard- and softwoods. Each of the sub-groups contains many species. Only solid wood is included in the table Fig. 3.12 but the framework could also include wood based products such as plywood, oriented strand board (OSB), chemically treated wood, thermowood as well as bamboo and grasses.

Category 2: Processing. Processing of the raw materials offer numerous possibilities of shaping wood into the basic elements that constitute the building elements of the wooden cladding. In order to get an overview of the processing options, this category has been sub-divided according to the principal choices in the process of shaping the basic elements. The choices can be described as deciding on the wood tissue, cutting pattern, shape and dimensions, surface character, drying method, as well as joining of the basic elements, provided that this is necessary. Following is a more detailed description of the six sub-categories.

The wood tissue

This sub-category defines the specific wood tissue for the basic elements. All possible options for choosing the wood tissue are present in this sub-category. Conventional choices are heartwood and sapwood either pure or mixed tissue. But the wood stem offers more options for tissue with interesting visual qualities. This could be pith- and juvenile-wood containing tissue, or reaction wood. It could be wood with or without bark. It could be knot-free or knot-containing wood, defined by the size and quantity of knots. The tissue could also be defined by its density. It could be blue stained wood or wood with chemical stains from the drying process. The point here is that any visually interesting feature has the potential to allow the creative use of wood in cladding design.

Drying method

This sub-category defines the way the wood is dried. Even though the drying method is not immediately evident in the finished product, the method used can add esthetic qualities to the basic element. The principal options in this sub-category are air dried and kiln dried material. Air drying techniques include drying of the wood planks in an outdoor, naturally ventilated roofed construction.

Wood can also be air dried when the tree is still standing on its roots in the forest. A traditional method is to cut off the treetop and to allow the wood moisture to evaporate naturally prior to the felling of the tree. Another related method is to fell the tree and leave the trunk with branches and leaves on the ground. Moisture is removed from the trunk as a result of ongoing photosynthesis, which continues for some time after felling. Fresh wood, also referred to as green wood, can be used directly in a construction without any form of drying prior to mounting. An example of this is the traditional Norwegian cladding type called Barn panel (Norwegian: *Låvepanel*), where the freshly cut planks are mounted directly onto the façade and left to dry.

Kiln drying of material is by far the most common way of drying wood in the industrialized wood-producing countries since it is much faster than air drying wood.

The cutting pattern

This subcategory defines the cutting pattern which is the specific way in which the tree trunk is cut into smaller parts. Conventional wood cutting patterns produce radially and tangentially cut material but there could be other less conventional patterns of interest designed to achieve a specific task in a cladding design. The anisotropy of the material, in conjunction with the cutting pattern, also defines some technical properties of the basic element.

The shape and dimensions of the basic elements

This sub-category defines the shape and dimensions of the basic elements. Within this sub-group there are unlimited options for creating unique basic elements for the cladding. Conventional shapes are boards with a rectangular cross-section. Among the shingle type of basic elements there is a tradition of a broad variety of refined shapes and dimensions.

The surface character

This sub-group defines the character of the wooden surface. Conventional types of surface characters are created by circular or band saws, in which cases the surface is left with the marks of the machine used. A newly sharpened saw blade can make the surface appear almost planed whereas dull blades leave clearly visible marks on the surface as testimony to the processing method. Planing is a conventional method of post-processing the sawn wood surface. Other distinct surface characteristics are cutting marks from axes or knives. These can be authentic handmade cuts or an industrial imitation of old craft. Splitting the wood is a traditional processing method which leaves the wood surface with a distinct pattern of torn fibers in the radial section of the material. Wood with bark still attached is another interesting option for lending the surface a distinctive appearance.

Joining of material

This sub-category defines the joining method, provided joining of the basic elements is necessary. Commonly used joining methods for extending the length of wooden boards are tongue and groove, finger-, scarf and butt joints. The deliberate use of joints to create an interesting visual interplay with the overall design has an esthetic potential which is rarely considered.

Category 3: Composition. The previous categories and sub-categories were about shaping the wood into its desired technical and esthetic properties. This third category is about arranging the processed material into the final composition of the cladding.

The composition of any wooden cladding can be described by the direction and the juxtaposition of the basic elements. The term direction is used to describe two principal directions: the direction of the material relative to the original position in the wood

stem, and the mounting direction of the wood elements in a cladding.

The terms for describing the directions relative to the wood stem are pith- and bark side, root and top. These directions have relevance in the design of an untreated wooden cladding. It is recommended to mount the boards with the pith side out. In tangentially cut boards with mixed heartwood and sapwood, the portion of heartwood is larger on the pith side, and hence mounting the boards with the pith side out maximizes the amount of heartwood that is oriented towards the weather side of the cladding.

The mounting direction of the boards relative to the root and top of the wood stem is perhaps of less importance in the design of a cladding however, some technical and esthetic properties could come into play in a cladding design. Root stem material (the lowermost part of the tree stem) contains more extractives compared to material cut out of the middle and top part of the tree stem. This property is of interest when using untreated wood in outdoor applications. In relation to an untreated wooden cladding, the use of root stem material mounted vertically with the root direction at the bottom could potentially increase the service life of the boards since the lowermost areas close to the ground are typically exposed to more humid conditions compared to those higher up. The growth pattern of the tree creates the characteristic conically shaped wood stem composed of layers of annual rings. In a tangential section of the stem, the annual rings overlap in a cascade type of arrangement. Theoretically, positioning the tangentially cut board vertically in a top up position helps water drain from the surface like from feathers on bird. By contrast, the top down position allows rain water to penetrate the individual annual ring layers, potentially leading water deeper into the wooden board. In order to keep track of the specific section of the wood stem as well as the board direction relative to the root and top it would be necessary to introduce a marking system throughout the whole production line and furthermore communicate this information to the end-user.

The term direction is also used to specify the mounting direction of the boards in a cladding. Vertical and horizontal directions are the most commonly used, however any direction can be used in a cladding design.

Juxtaposing the basic elements into a composition can be done in numerous ways. Three principal juxtapositions of the basic elements seem to cover the principal options: adjacent, non-adjacent (also referred to as open) and overlapping juxtapositions. The adjacent juxtaposition is where the basic elements are positioned close to the neighboring material. This can be done by mounting the boards in a close alongside composition or joined by tongue and groove. Whereas the alongside composition typically has tiny air gaps of varying size between the boards, the adjacent juxtaposition joined by tongue and groove is tight and has no air gaps. The non-adjacent juxtaposition is where the basic elements are positioned apart from the neighboring material leaving clearly visible air gaps between the individual elements. This type of composition is often referred to as grating or louver.

The overlapping juxtaposition is where the basic elements alternately over- and underlie neighboring material. This can be in the form of inclined cascade type of

composition as seen in clinker and shingle style claddings. Another very common overlapping juxtaposition is the board and batten type of cladding. The overlapping types can also be in the form of interwoven material. Weaved compositions are also referred to as latticework.

Category 4: Fastening. This category finalizes the construction of a wooden cladding. Fasteners are a very important part of the visual appearance of a wooden cladding and the deliberate use of fasteners to create a visual interplay with the wooden pattern represents an esthetic potential which is unfortunately rarely used. More often than not material is carelessly mounted and the result is visually poor. Fasteners may be visible or invisible. When visible, the fastening pattern constitutes an important visual element in the esthetics of the cladding. Fasteners come in countless shapes, sizes and materials. Commonly used fasteners are steel screws and nails but any fastening device that serves the purpose can be used to create a visually interesting addition to the pattern of the cladding. Invisible fastening is often seen in clinker and shingle type of claddings. Hiding the fastening devices behind overlapping components or mounting from the back, allows for a design that expresses the shape, cutting pattern and surface character of the basic elements, free of visual interference from any fastening device.

The framework Fig. 3.12 provides an overview of design options and demonstrates the many variables that might be taken into consideration when designing wooden claddings. The framework can be used as a source of inspiration and a decision-making tool in the design process. It also allows for a structured approach to the description and analysis of the components in any given cladding. In relation to weathering the framework allows for a structured approach in identifying elements of interest and relevance to the topic.

3.1.4 Concepts on the relations between cladding design, weather exposure and weathering colors

The final group of ideas and concepts that originated from the study of the small scale cladding models concerns ways of approaching a cladding design in relation to weather exposure and color development.

Current practice on the color development of untreated wooden claddings is based on case studies. The assessment of weathering color addresses the relation between the façade and cladding design, and the color development. The actual weather exposure of the cladding in question is left out.

The state of the art perception of the relation between cladding design and color development is based on the understanding that claddings with no protruding elements (claddings with no shade) are exposed to even weather resulting in even weathering color. By contrast, designs with protruding elements (claddings with shade) are exposed to uneven weather, resulting in uneven weathering color development. Even color is typically used as synonym for the grey weathering color, whereas uneven color deviates from the weathering grey. Further specifications on uneven color schemes are left out in literature on wood weathering (SINTEF Byggforsk 2008).

Two different approaches are relevant for the analysis of the relation between cladding

design and color development: one that is based solely on the design of the cladding and the other that is based on the cladding design in combination with information about the expected exposure conditions. This principal distinction of separating the analysis according to the level of information is important. It clarifies whether the analysis deals with evaluation of the weathering color development of the cladding *prior* to any knowledge of the actual exposure conditions, or if the analysis includes information on the actual exposure conditions. The first type of analysis can be perceived as evaluating the weathering color potentials or options of a cladding design whereas the latter allows for a more realistic description of the colors and patterns to be expected.

Following are ideas on how to approach the relations between cladding design, weather exposure and color development.

Categorizing claddings according to geometry

Claddings typically have traditional and/or commercial names. But instead of naming a cladding according to its proper noun, claddings can be addressed according to the geometry. This concept allows for identifying and defining elements common to all types of claddings and to establish a vocabulary that can be applied to any cladding.

All imaginable claddings can be grouped into two major categories: “plane” and “relief” types of claddings. Plane types of claddings have a two-dimensional geometry whereas relief claddings have a three-dimensional type of geometry.

Deconstructing a cladding to its constituent surfaces

Deconstructing a cladding to its constituent surfaces and analyzing the surfaces individually allows for a more nuanced approach to the understanding of a cladding in relation to weather exposure and color development.

Following observations based on the study of the MDF cladding models apply for the weather side surface of plane type of claddings:

- Plane type of cladding have one exposed surface
- The plane type of cladding is non-shaded hence only one surface shade option
- The surface has only one direction towards the sky hence only one weather exposure option
- Weather has uniform access on the total surface area hence the surface has a uniform exposure potential
- The uniform exposure potential allows for a mono color weathering potential of the total surface area of the cladding





Categorizing claddings according to geometry

Geometry of cladding	Plane types of cladding (2-D)	Relief types of cladding (3-D)
----------------------	-------------------------------	--------------------------------





Deconstructing a cladding to its constituent surfaces

	Plane types of cladding (2-D)	Relief types of cladding (3-D)
Number of exposed surfaces	1	> 1
Surface shade options	1	> 1
Surface directions towards the sky	1	> 1
Surface weather exposure potential	Uniform	Uniform and differentiated
Surface weathering color potential	Mono color	Mono and multi color

Surface shade options of plane and relief type of claddings

	Plane types of cladding (2-D)		Relief types of cladding (3-D)			
Surface shade options	Non-shade		Non	Full	Attenuated	Gradual
Diffuse light visualization						

Examples of claddings with different surface shade pattern

	Plane types of cladding (2-D)		Relief types of cladding (3-D)			
	A		B	C	D	
MDF cladding models						

- A: Plane type of cladding with one weather side surface and no surface shade.
- B: Relief type of cladding with four weather side surfaces. The foremost surfaces are non-shaded the remaining surfaces have gradual shade.
- C: Relief type of cladding with four weather side surfaces. Foremost surfaces are non-shaded, downward facing surfaces are fully shaded. The remaining surfaces have gradual shade.
- D: Relief type of cladding with two weather side surfaces. Front faces have gradual shade, downward towards the ground inclined surfaces have attenuated shade.

Figure 3.13 Concepts on the relations between cladding design, weather exposure and weathering colors of untreated wooden cladding.

Following observations based on the study of the MDF cladding models apply for the weather side of relief type of claddings:

- Relief cladding types have several exposed surfaces
- The relief type of cladding create shade hence more than one surface shade option
- The surfaces point towards different directions of the sky hence a differentiated weather exposure potential of the individual surfaces of relief type of claddings
- Weather has differentiated access to the surfaces hence a differentiated exposure potential of the individual surfaces.
- The differentiated exposure potential allows for both mono and multi color weathering potential of the individual surfaces and of the cladding

In a typical building context a cladding would cover, for instance, four façades hence also face four different compass directions. Weather, i.e. precipitation and solar radiation, is unevenly distributed in the sky, and therefore the four façades of a typical building construction will generally be exposed to four different weather conditions. Plane type of claddings covering four façades that face four different directions will generally be exposed to four different weather conditions. Likewise, relief type of claddings facing four different directions could also be facing four different weather conditions. However, due to the geometry of the relief type of claddings, that per definition have more than one surface, surface shade and different directions towards the sky, the exposure conditions are significantly more complex compared to plane type of claddings.

As long as the actual in-situ weather conditions are unspecified, an evaluation of the surface exposure should be assessed as an exposure potential only. Once the in-situ weather is known however, it is possible to evaluate the actual exposure and weathering color development of the surfaces.

Further analysis of the surface shade options of plane and relief type of claddings

The small scale models used in this study demonstrate that the surface shade of the individual surfaces in a relief type of cladding varies. The study of surface shade patterns was initially assessed through visual observations only and later further developed to be visualized by diffuse light patterns calculated by means of solid angles. The approach was to visualize a diffuse light source located at a distance from the cladding and to calculate the diffuse light intensity distribution on each individual surface in a cladding with the resolution of 1mm^2 . The method is demonstrated in Section 3.2.

Four principal surface shade types were established:

- non-shade
- fully shade
- attenuated shade
- gradual shade

The non-shaded surface has no shade. In a diffuse light visualization calculated by means

of solid angles, this surface shade type is uniformly white due to 100% access of diffuse light to the total surface area. This is characteristic of the plane type of claddings as well as the foremost protruded, non-shaded surfaces of the relief type of claddings.

The fully shaded surfaces are in complete shade. In a diffuse light visualization this surface type is uniformly black due to no access of diffuse light. This is characteristic of downward facing surfaces.

The term “attenuated shade” was introduced to describe a surface shade pattern characterized by uniform diffuse light intensity due to identical solid angles as is the case with the non- and fully shaded surfaces. The diffuse light intensity of the attenuated shade is less than 100% and more than 0%. This particular surface shade option is characteristic of downward, towards the ground, inclined surfaces.

The term “gradual shade” was introduced to describe a surface shade pattern of varying diffuse light intensity. This shade pattern emerges in situations where diffuse light has varying degree of access to the surface area hence the variations in the solid angles. This seems to be characteristic of many surfaces in relief types of claddings where a gradual shade pattern is created due to protruding neighboring elements.

Deconstructing a cladding to its constituent surfaces and analyzing the shade conditions of the individual surfaces allows for comparing the shade pattern of different types of cladding design. This approach involves interesting perspectives and could be further developed as part of a more detailed study on how different types of surface shade patterns relate to different types of color development.

Note that the term “shade” is used to describe the shade caused by the geometry of the cladding when exposed to diffuse or indirect light. The shade pattern generated by diffuse light is always the same. The shadows caused by direct light, which in an outdoor environment originate from sun rays, vary with the sun’s position relative to the surfaces of a cladding. Note also that diffuse light and shade must not be confused with the actual weather exposure or color development.

Fig. 3.13 sums up the principal differences between plane and relief types, as well as the ideas on how to assess relationships between cladding design, weather exposure and color development.

3.2 Research design

3.2.1 Initial consideration on methods for developing weathering colors

Weathering of wooden claddings can be created artificially in laboratories or naturally in an outdoor environment. The principles behind the methods for artificial weathering are to simulate temperature, precipitation and radiation in a controlled environment. The problem with present day artificial weathering machines is the lack of ability to simulate the growth of dark walled fungi responsible for the grey surface color development. This single factor, omnipresent in nature, plays an important part in the weathering color development of wooden claddings. Leaving out this factor results in weathering color development which significantly differs from the coloration developed in a natural outdoor environment. This leaves the laboratory methods with little relevance

to the present study since wooden façades and claddings will be exposed to a natural outdoor environment. Studying weathering under natural weather conditions and collecting data on a natural time scale was therefore the only option for this study.

There are two principal options for the study of naturally developed weathering colors of wooden claddings: studies of already weathered wooden claddings i.e. case studies or design of an experimental setup where the development of weathering colors on wooden claddings can be followed over time.

Both options have benefits and disadvantages. Studies of already weathered wooden claddings have the obvious advantage of being ready to study and document. The study of already weathered wooden claddings is however an unreliable method. There follows a discussion of the problems encountered during preliminary studies of weathered wooden claddings at an early stage of developing this project.

The lack of control of factors influencing the weathering color development of the cladding

In a case study the factors controlling the weathering color development are all fixed prior to the study. This gives no option of studying the effect of a single factor with all factors kept fixed. Further factors outside the scope of the study may influence the color development: in a typical building context, elements such as roof hang, window sills, lamps and other elements may be present as part of a façade and these are known to affect the color development as discussed in Chapter 2. Neighboring constructions, vegetation such as tall trees and the like are also potential factors to interfere with the color development of the cladding. Any interference with the color development, apart from the factors included in the study, can be a source of disturbance and lead to inaccurate conclusions when analyzing the weathering color development of the cladding.

The problem of comparability of weathering colors of different building façades

The weathering color development of a building façade is unique and cannot readily be compared to the color development of another building façade. Differences in in-situ weather conditions, duration of the exposure to weather, material and surface quality and potentially factors in the physical surroundings makes comparison of color development between different building façades problematic.

The problem of reliable information on building history

Obtaining accurate information on the building history can be very difficult. Lack of accurate knowledge may lead to wrong conclusions. Building maintenance, replacements and remodeling may be part of the building history which has played a role in the weathering color development. Another aspect of this problem is accurate information on material specifications such as wood species and tissue. This particular problem became clear during the study of the façades of Aigen Kindergarten in Salzburg. In a guideline publication (SINTEF Byggforsk 2008) it is stated that this façade is made of larch, alternately planed and unplanned board surfaces. The architect Max Rieder claims that the cladding is made from alternating unplanned fir and planed larch (Rieder, Max 2008).

Observations made by this author are that all surfaces appear to be planed. Which is the correct wood species and surface quality would need further extensive investigation. This example demonstrates the potentially unreliable information regarding material specifications. Fig. 1.1 example 9-10 shows photos of this façade.

The lack of data from the early stages of weathering

Investigating color development of claddings at any stage after the onset of exposure means that early stages of weathering remain unknown leaving possibly interesting information undiscovered. The case of Aigen Kindergarten in Salzburg also demonstrates this particular aspect. A visit to the house in 2008, 10 years after construction, showed that the East facing façade was almost uniformly grey colored. A publication (SINTEF Byggforsk 2008) published ten years after construction includes a picture of the same façade showing a clearly two-colored, vertically striped pattern of this cladding. The time of documentation of the striped façade is not stated in the publication. The transition from the striped to the mono color grey appearance remains undocumented. Fig. 1.1 example 9-10 shows photos of the striped façade as it appeared in the early stages of weathering together with photos that show the weathering color after ten years of exposure.

The problem of data acquisition and close up inspection of material surfaces

Data acquisition and close up inspection is a potential problem when documenting colors of real life building façades. In the field, registration of weathering colors is limited to methods that can be carried out on location, since demounting of façade material for further studies and color registration is typically not a viable option. In the case of color registration by means of photography, the recorded colors are influenced by different lighting conditions as well as reflections from the surface. Also it should be noted that positioning a camera at favorable angles and distance to the façade may be difficult in some instances due to conditions in the terrain, vegetation or other elements obstructing the view from the best shooting angle.

The alternative to case studies is the experimental method. Advantages of an experimental method are that the above mentioned problems of case studies can be eliminated. A major advantage of the experimental method, as opposed to case studies, is that the setup can be designed according to specific demands to clarify areas of particular interest of the study. It is possible to design the experiment in a way which allows for comparing weathering color development of different types of claddings. Other advantages are the control over material specifications, knowledge of weathering history, possibility of documentation of early stages of the weathering process and access to the site at any time of the day. There is no need for coordination with private owners, and no limitations for demounting material for closer inspection and color registration.

One problem common to case- and experimental methods is to determine at which point a distinct and permanent color pattern has developed. This question is left open. Having analyzed the benefits and drawbacks of artificial versus natural weathering, and

case studies versus experimental methods, it was decided to proceed with an experimental study, in which wooden claddings were to weather in an outdoor environment.

3.2.2 Strategy for the experimental design

The overall idea for the experimental design was to create a setup that could simulate conditions as close to real life weathering of wooden claddings as possible in order to generate data with maximum comparability and relevance to real life situations. The strategy was to simulate a standard type of house with wooden façades. The standard reference house was defined as a house with four vertically standing façades perpendicular to one another and pointing to four different compass directions. A typical house has openings for doors and windows in the façade, roof hang and possibly other elements apart from the cladding itself. This part of the typical house reference was omitted in order to create a situation, in which the cladding could develop weathering colors without interference from building elements and surroundings.

The strategy for the experimental setup was to design a number of different claddings, produce four samples of each cladding type, and mount the samples in a vertical position towards the four cardinal compass directions, north, south, west and east.

The strategy for the construction of the claddings for the experiment was to follow current recommendations for best practice constructing methods for untreated wooden claddings, as recommended by the Norwegian building research institute, SINTEF (SINTEF Byggforsk 2008). The recommendations are as follows:

- Use heartwood of a species that exhibits long natural durability
- Radially sawn material for best durability and stability performance
- Ventilated construction allowing for drying of the material
- No water traps in the construction
- Protection of end grain from direct water exposure
- A minimum distance of 300mm between the ground and the construction
- Lower end of vertically standing boards cut at an angle for creating a dropping point in order to minimize capillary suction through the end grain

In addition to the technical specifications, the following strategies were employed to mitigate the risk of undesired color development from factors other than the cladding itself:

- The claddings were to be assembled from the back surface in order to avoid color development from the fastening device on the weather side
- Fasteners were to be of stainless steel to avoid risk of corrosive stains affecting the color development on the weather side
- The claddings were to be constructed using only whole board lengths to avoid color development related to joined boards

- The back surfaces of the claddings were to be protected from direct weather exposure to mitigate the risk of construction side exposure influencing the color-development on the weather side

The solution for protecting the construction side from direct exposure as well as protecting the end grain was to insert each cladding in a protective frame. In addition, the protective frame would serve as a system for mounting the claddings onto a supporting frame at the site of the experimental setup. The roof of the protective frame could be compared to a real life situation where a roof would also protect the upper ends of the wooden cladding.

The drawback of this solution was that the protective frame could influence the weathering color development however, no better alternative was found. Matters regarding the influence of the protective frames are discussed in Chapter 4.

3.2.3 Design of cladding types for the experiment













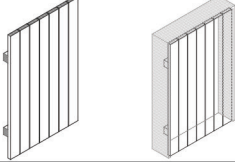



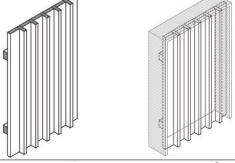



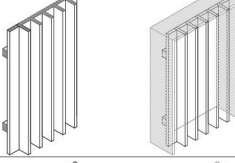

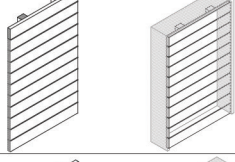

The small-scale cladding models and the subsequent analysis served as inspiration for the selection of cladding geometries for the experiment. In fact, all cladding types were of interest for direct study but for obvious practical reasons a limited number of cladding types had to be selected. The overall strategy was to include plane as well as relief types of claddings. Claddings with different material directions as well as open and closed structures were also to be included.

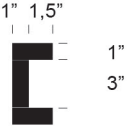
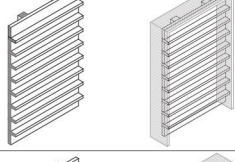
Eight different types of claddings were chosen, representing vertical and horizontal as well as horizontally-inclined material directions. The vertical and horizontal claddings were to be represented in two different depths. The idea of designing similar types of relief claddings with variations in depth originated from the cladding models that inspired the approach of addressing the aspect of depth variations. Having decided on the types of claddings to be included in the experiment, it was then decided to design the claddings with proportionally interrelated ratios. The principle behind the proportional system was as follows: a standard size unadjusted wooden board measuring (B x W) 1" x 3" or 25mm x 75mm was chosen as the proportioning unit of the claddings. All dimensions in the claddings were derived from this standard. With this research design it was possible to study the effects of the factors:

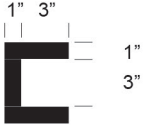
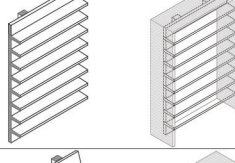
- cladding geometry (plane and relief)
- cladding orientation towards the sky (four compass directions)
- surface orientation towards the sky (vertical, horizontal and inclined)
- relief depth (two depths)

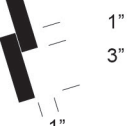
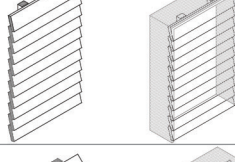
The effect of the factors could be studied individually as well as in any combination.

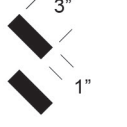
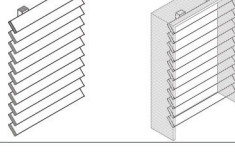
Having decided on the cladding types and the proportions, a 1:1 scale prototype was built to determine the actual size of the claddings to be constructed for the experiment. Considerations regarding the size of each cladding were that the size should be sufficiently large to allow for the development of a weathering pattern which would be

MDF model reference	Proportions 1" x 3" board	Cladding design Plywood frames measure 150/200 x 600 x 900mm	Cladding No.	Wood claddings
			1	
			2	
			3	
			4	
			5	
			6	
			7	
			8	

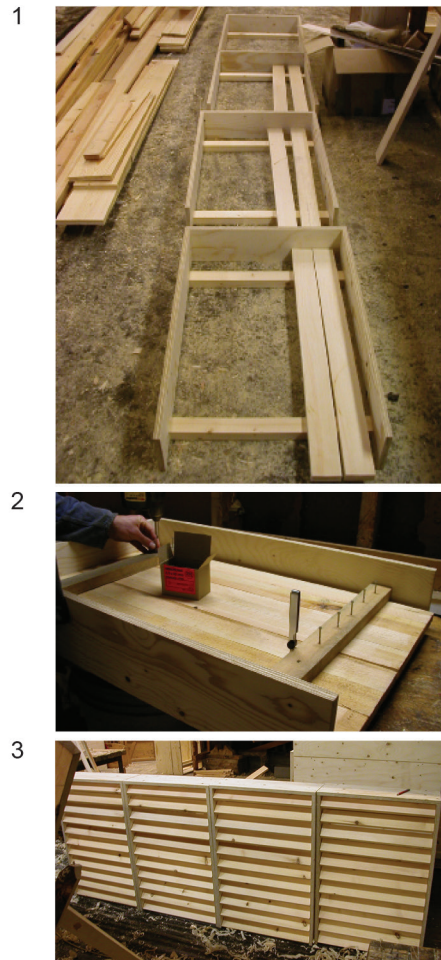
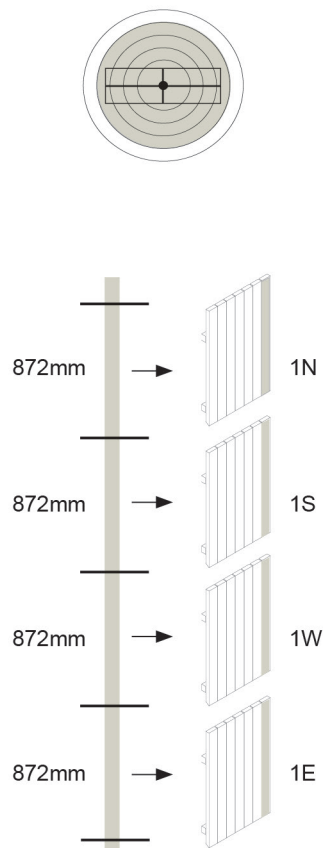

Figure 3.15 Principle for the construction of four identical the claddings. Radial cut heartwood of Scots pine (*Pinus Sylvestris* L.) was used. The long boards were divided into four shorter boards with the length needed for the vertical and horizontal claddings. Every four boards from the same larger board were distributed in corresponding places of the four samples of a cladding. Photo 1 and 2 show the principle for the construction of Cladding 1 and the fastening of the boards from the back of the cladding. Photo 3 shows the four samples of Cladding 8. Photo © Majbrit Hirche.

Figure 3.14 Left. MDF model references and the interrelated proportions of the claddings, the cladding design, cladding numbers and photos of the wood claddings for the experiment. Large scale photos of the claddings are shown in Figs. 3.16-3.30.



Figure 3.16 Cladding 1, Sample 1S. The dark horizontal shade on the upper part of the surface is a shadow from the wire fence around the Voll research field. Photo © Majbrit Hirche.

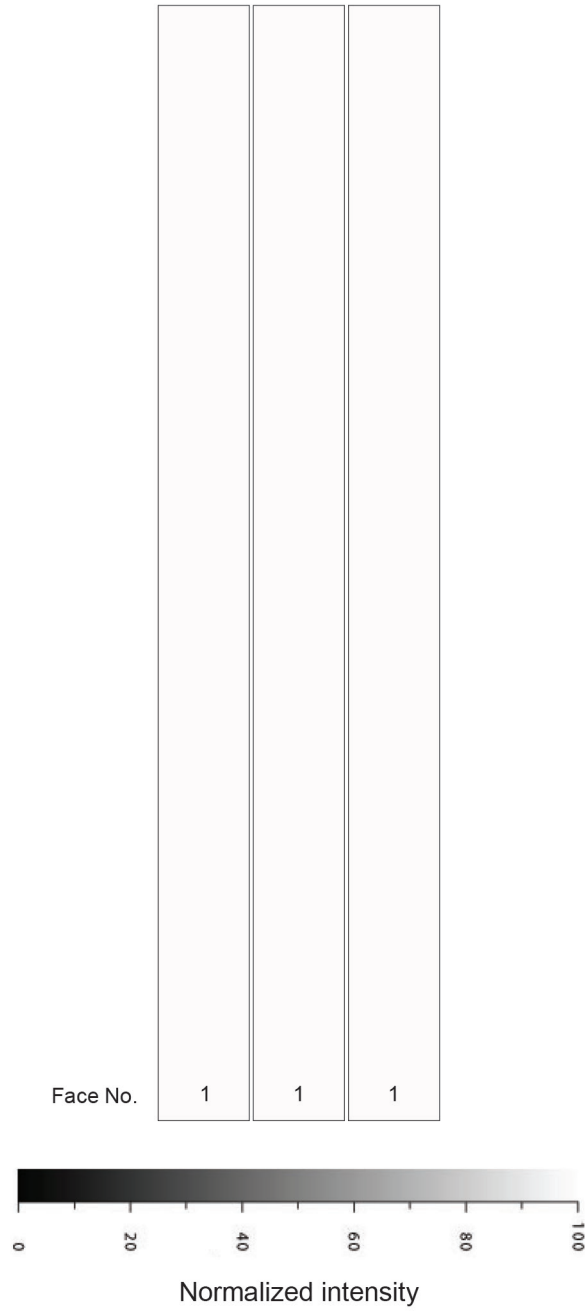

Figure 3.17 Diffuse light visualization Cladding 1. Cladding 1 is non-shaded.



Figure 3.18 Cladding 2, Sample 2S. The dark horizontal shade on the upper part of the surface is a shadow from the wire fence around the Voll research field. Photo © Majbrit Hirche.

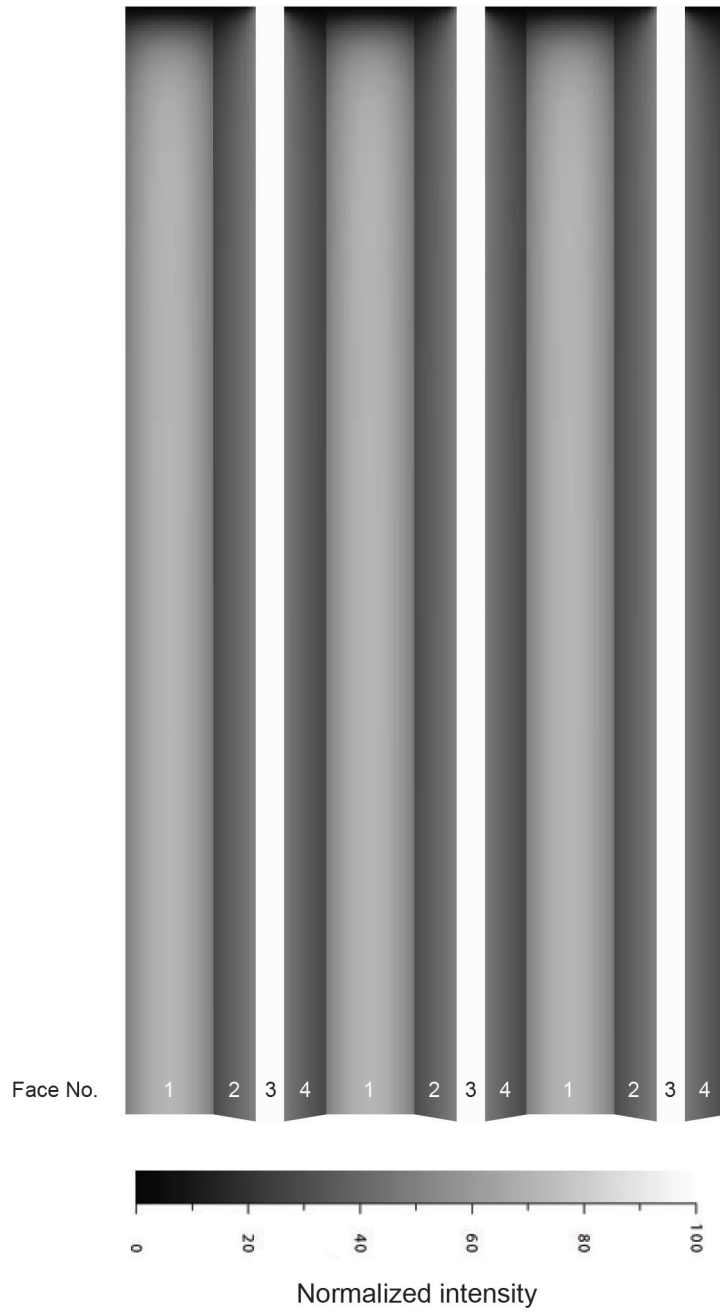

Figure 3.19 Diffuse light visualization Cladding 2. Face 3 is non-shaded. Face 1, 2 and 4 have gradual shade. Face 2 and 4 have identical surface shade.



Figure 3.20 Cladding 3, Sample 3S. Photo © Majbrit Hirche.

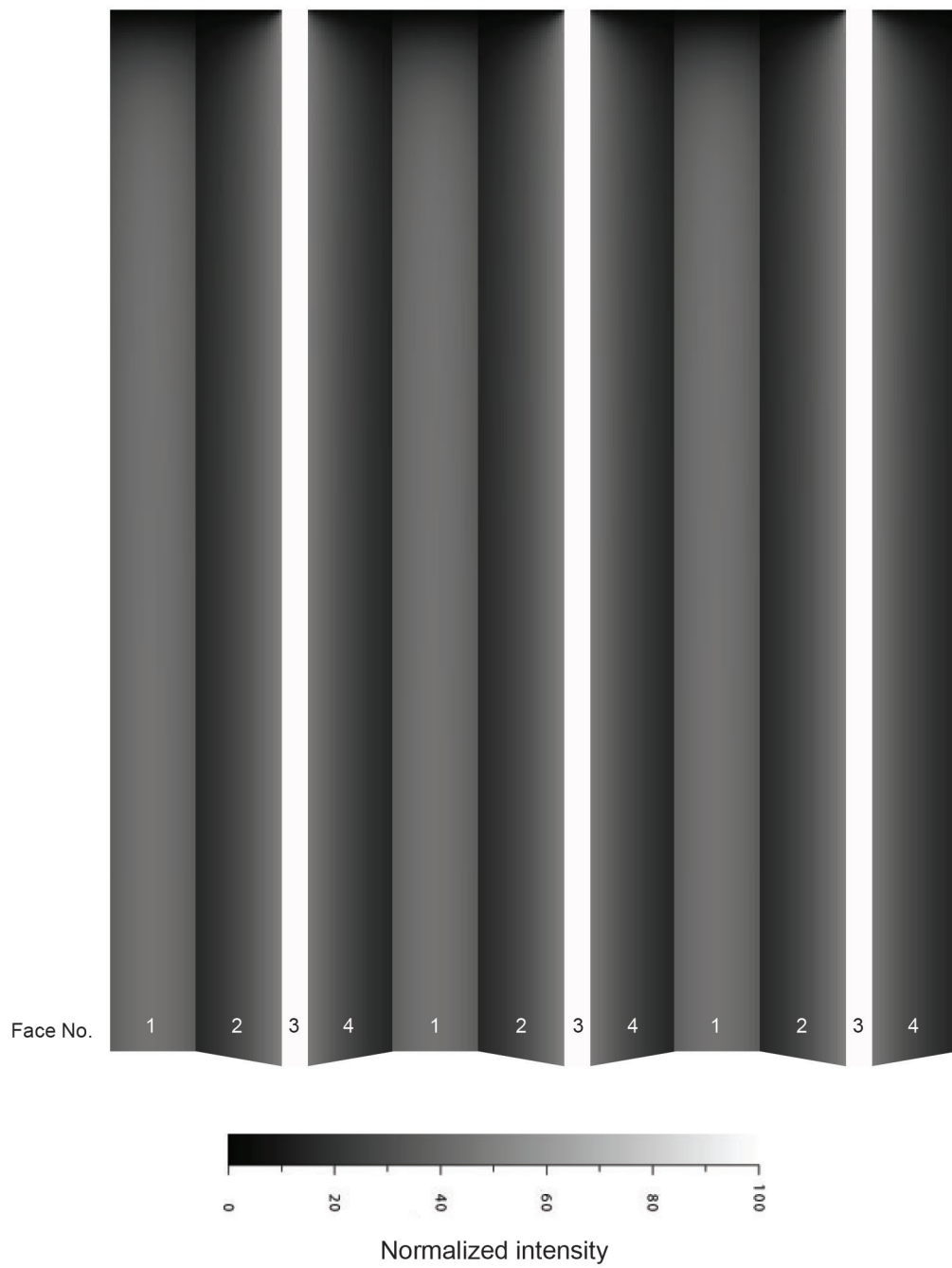

Figure 3.21 Diffuse light visualization Cladding 3. Face 3 is non-shaded. Face 1, 2 and 4 have gradual shade. Face 2 and 4 have identical surface shade.



Figure 3.22 Cladding 4, Sample 4S. The dark horizontal shade on the upper part of the surface and the vertical shade on the right side are shadows from the wire fence around the Voll research field. Photo © Majbrit Hirche.

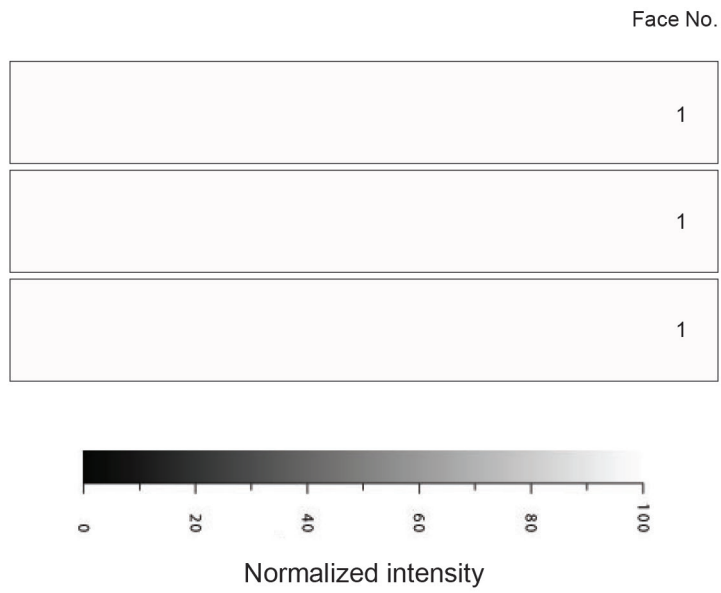

Figure 3.23 Diffuse light visualization Cladding 4. Cladding 4 is non-shaded.



Figure 3.24 Cladding 5, Sample 5S. Photo © Majbrit Hirche.

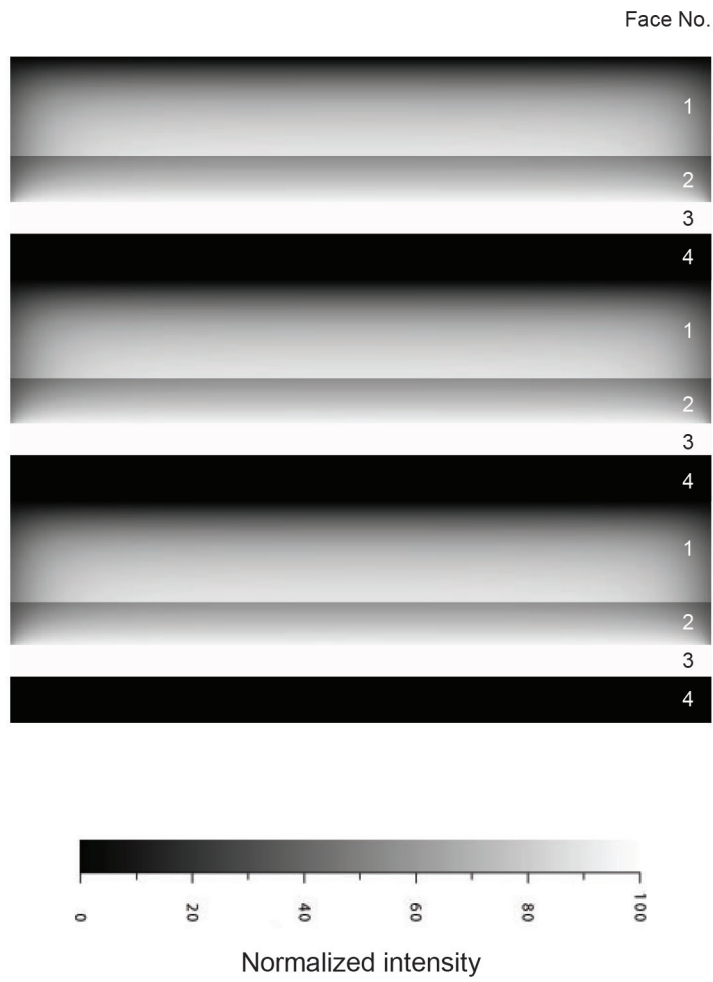

Figure 3.25 Diffuse light visualization Cladding 5. Face 1 is non-shaded, Face 4 is fully shaded. Face 1 and 2 have gradual shade.



Figure 3.26 Cladding 6, Sample 6S. Photo © Majbrit Hirche.

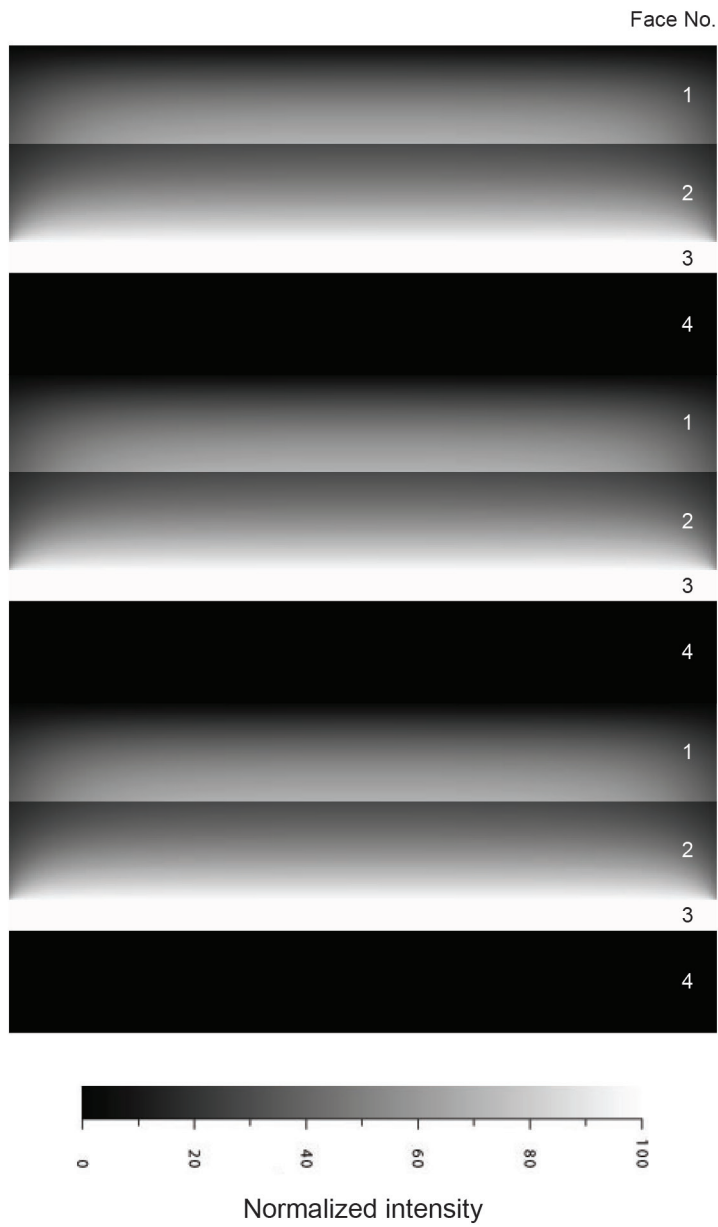

Figure 3.27 Diffuse light visualization Cladding 6. Face 1 is non-shaded, Face 4 is fully shaded. Face 1 and 2 have gradual shade.



Figure 3.28 Cladding 7, Sample 7S. Photo © Majbrit Hirche.

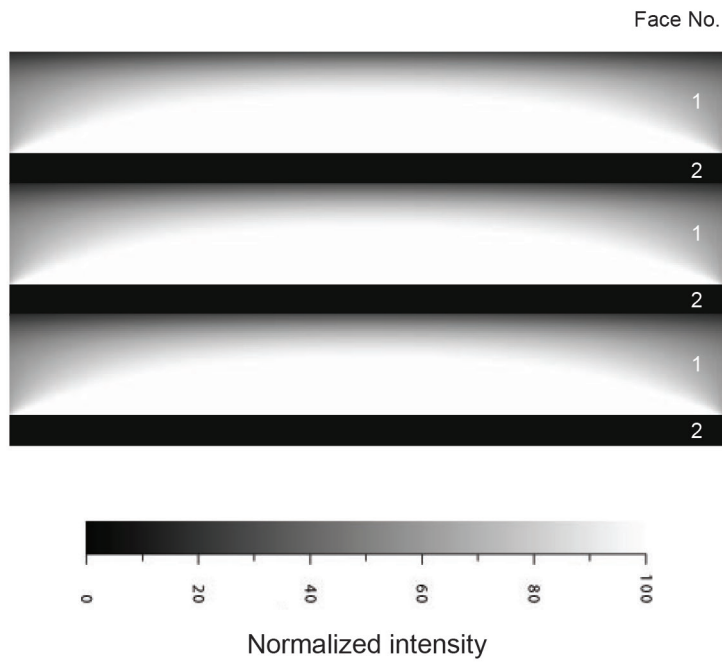

Figure 3.29 Diffuse light visualization Cladding 7. Face 1 has gradual shade, Face 2 has attenuated shade.



Figure 3.30 Cladding 8, Sample 8S. The dark vertical shade comes from a post in the fence around the Voll research fields. Photo © Majbrit Hirche.

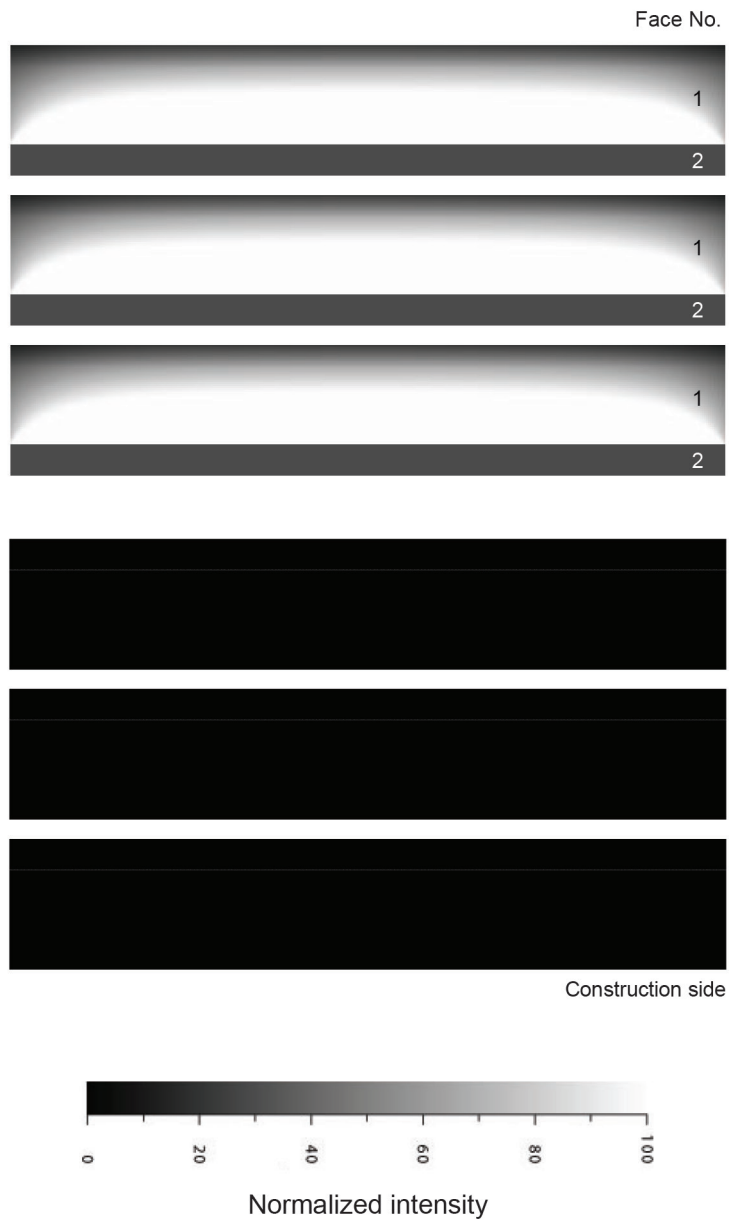

Figure 3.31 Diffuse light visualization Cladding 8. Face 1 has gradual shade, Face 2 has attenuated shade. The construction side surfaces are fully shaded.

comparable to a real life situation as well as avoiding edge effects from the protective frame. In addition it had to be possible for one person to manually handle a sample. It was decided that the claddings should have the approximate size 900mm x 600mm (H x W). The depth of the protective frame would depend on the geometry of the cladding. Fig. 3.14 shows a table of the sketch model references, the proportions and dimensions of the claddings. A small scale photo of a sample of the finished claddings to be used in the experiment are also shown. Drawings of the eight cladding types are shown in Appendix A.

The shade patterns of the claddings chosen for the experiment were visualized by means of diffuse light simulations. The intention was to demonstrate the concept of surface shade developed through study of the MDF cladding models. The visualizations of the surface shade pattern have interesting perspectives. The method allows for an easy identification of the four principal types of surface shade pattern options: non-, full-, gradual, and attenuated shade. The visualizations also make comparison of the shading patterns of different claddings and surfaces easy. The images provide an excellent visual common ground for a discussion of the shading patterns of a cladding. Digital modeling of diffuse light patterns could be an interesting tool in a preliminary analysis of the weathering color potential of a cladding prior to actual weather exposure, as discussed in Section 3.1. The diffuse light simulations are shown together with the wooden claddings for the experiment in Figs. 3.16-3.31.

3.2.4 Method for registration of weathering colors

Having decided for the overall strategy of the experimental setup and chosen which cladding types to include in the experiment, the next task was to decide which method to use for the documentation of the weathering colors as well as the frequency of the documentation. The “close to real life” philosophy which guided the strategy for the experimental design was also present in the considerations regarding documentation and presentation of the weathering of the claddings. A requirement for the method of registration of the weathering colors should be capable of communicating the colors and color patterns as closely to a real life experience as possible. An additional requirement was that the method used allows for comparison between the weathered surfaces.

The requirement for documentation that could communicate weathering colors as closely to real life as possible ruled out the often-used color registration method of spectroscopy where local areas of the surface are measured (spot measurement) and the colors described in RGB values. Data obtained by spectroscopy does not provide any sense of a real life experience of colors.

Color registration by means of photography seemed at first a good option, since data could provide a good sense of real life color and color patterns. A 1:1 mock-up of cladding Number 3 was built and photographed. It turned out that documenting the colors by means of photography had serious drawbacks. One important requirement was to make sure that surfaces were uniformly illuminated in order to obtain comparable colors in the photos. Plane cladding types have no surface shade and the total surface area can be uniformly illuminated. For this type of cladding geometry photography is a workable

method. With relief types of claddings it is not a good solution. The geometry produces shade, which causes different degrees of obscurity on the surfaces. This affects the color experience since colors in obscured areas i.e. in shaded areas, appear darker than those in less or non-shaded areas of the same cladding. Illuminating the obscured areas by means of artificial light generated shadows, which only served to complicate the situation further.

Another problem of documenting colors of relief type of cladding using a camera is that it is not possible to capture all surfaces within the same focal plane as used for the plane type of cladding. Either the cladding or the camera or both must be tilted in order to capture all surfaces. In changing the distance and angle between the object and the detector plane, the demand for uniform lighting for comparison of colors is compromised. It takes only one photo to document a plane type of cladding whereas documenting a relief type may take several photos. One way of overcoming the problems that the method of photography caused would be by making old fashioned drawings of the surfaces. Limitations of drawings are that colors are likely to be reduced to fewer nuances thus compromising the demand of a representation that is as close to real life experience as possible – unless of course the drawings are made with an accuracy comparable to that of a Renaissance painter, alas, not an option in this study.

Having studied various methods for color registration, the solution was to scan the weathered board faces in a flatbed scanner. This method was inspired by the work of Petra Rütter who used the method in her Ph.D. work to document weathering colors of wooden surfaces (Rütter, P. 2011). A few test scans were made to check the accuracy of the color reproduction, and it turned out that the level of detail was amazingly good. The benefit of using a flatbed scanner was that all surfaces would be documented in high resolution images with the same distance and source of illumination, making it possible to compare the color development of the surfaces. The drawback of this method was that the three-dimensional experience of a relief type of cladding would be lost since the representation of the claddings would be in the form of its individual surfaces. However this drawback could be compensated for by comparing the scanned surfaces to photographs of the respective claddings.

3.3 Experimental procedures

3.3.1 Production of claddings for the experiment

The claddings for the experiment were constructed in collaboration with carpenters at the coastal heritage museum in Rissa outside Trondheim. Radial cut heartwood of Scots pine (*Pinus Sylvestris L.*) delivered by Materialbanken in Røros, Norway was used. This company has a history of delivering high quality wood products for building projects.

Weather side surfaces were planed in order to secure identical surface quality prior to weather exposure. The claddings were mounted from the back surface with stainless steel grade A4 screws. Lower ends of vertical claddings Numbers 1, 2 and 3 were cut at an angle of approximately 45° to create a dropping point for minimizing capillary suction. Horizontal upward facing surfaces in claddings Numbers 5 and 6 were planed in

an approximately 2° downward sloping gradient to allow rain water to run off the surfaces.

Four samples of each cladding type were built. The principle for constructing four similar samples was as follows: the long boards were divided into four shorter boards with the length needed for the vertical and horizontal claddings. Every four boards from the same larger board were distributed in corresponding places of the four samples of a cladding. This methodology made it possible to observe the weathering color development of material with the same origin exposed to different weather types. Fig. 3.15 shows the principle for building four samples of the same type of cladding together with photographs from the building process.

Each cladding was mounted in a frame made of 18mm spruce plywood. The outer dimensions of each frame were 900mm x 600mm. An air gap of 5mm between the plywood frame and the cladding allowed for air circulation. The back surface of each frame was provided with a layer of asphalted roofing felt in order to prevent direct weather exposure on the construction side of the claddings. The frames were designed with a simple system for easy mounting on and demounting from the supporting frames at the experimental site. Due to differences in the depth of the cladding types, plywood frames of 150mm and 200mm depth were made. The site plan Fig. 3.24 shows the depth used for each cladding as well as the actual location on the supporting frames at the experimental site. Photographs of each cladding type are shown in Figs. 3.16–3.32 together with diffuse light simulations of the claddings. Note that the shade from the protective plywood frame is included in the diffuse light simulations. The simulations are displayed according to the standard for displaying patterns in textile design, where the pattern repeat is showed three times in order to help the human eye understand the whole motive.

3.3.2 Experimental setup at Voll research fields

The experiment was carried out at an open field at Voll field station operated by SINTEF-Byggforsk. The field is located at Jonsvannsveien 159 in Trondheim, Norway. The geographical coordinates are: latitude 63°24'38"N., longitude 10°27'14"N. at an altitude of 127m A.S.L.

The experiment started in February 2006 and is still running. Two vertical supporting frames for mounting the claddings were constructed. The original intention was to setup the experimental claddings to face the cardinal compass directions, but for practical reasons this was not possible at Voll. The normal directions of the mounted claddings were 354°, 174°, 254° and 74° corresponding to approximately north, south, west and east respectively. The claddings were mounted with a minimum clearance of 600mm between the ground and the lower end of the cladding in order to minimize the risk exposure to raindrop splashes and snowdrifts from the ground. Fig. 3.32 shows the site plan and an aerial photograph of the Voll testing fields.

3.3.3 Registration of weathering colors and display of the data

After 20 months of exposure to natural climate at Voll from February 11th 2006 to

November 1st 2007 the experimental claddings were demounted from the supporting frames and dried in an indoor ambient climate. All board faces were marked with a number and the claddings disassembled. Frottages were made of the end grain of the claddings and later used to identify possible areas of sapwood. The frottages are shown in Appendix B.

The weathered board faces were scanned using an A3 Epson GT15000 flatbed scanner and scanned at a resolution of 300 ppi. For the sake of control of the scanning quality and later reproduction in print a Kodak color scale was glued to the glass plate of the scanner and scanned with every image. For maximum authenticity and through fear of damaging the weathered surfaces, there was no cleaning of the surfaces prior to the registration of colors. This is particularly evident on the east facing horizontal claddings Numbers 5 and 6, where bird droppings cover most of the upward facing surfaces.

The lengths of the boards were larger than the length of the scanner hence each half of all board faces needed scanning separately. Whereas the total length of the horizontal boards could be covered in two scanning operations, the vertical boards would need scanning three times to capture their total length. It was decided to scan the vertical boards only twice and accept a minor gap in the registration at the middle of each vertical board. The scanned images were post-processed in order to create visually clearer images of the individual board surfaces. All scanned board faces were cut out of the original digital image, rotated and the two halves that constituted one board were merged into one image. The area of the board faces that had been covered by adjacent boards were cut out of the image. The digital post-processing was done using Photoshop. Fig. 3.33 shows the phases in the scanning and post-processing work flow.

Some of the scanned surfaces have differences in color nuances on the two halves of the same board. An example can be seen in Fig. 4.43 Sample 5E, Face 4. There seem to be no color differences when comparing the color nuances of the Kodak color scale. It seems that the light from the flatbed scanner has different reflection depending on which direction the wooden surfaces are scanned in.



Figure 3.32 Upper photo. Aerial view of the Voll research fields in Trondheim operated by SINTEF-Byggforsk. The black rectangle indicates the area of the site shown on the opposite side. The dashed circle marks the area where Voll Automatic Weather (AWS) station is located. Photo © GisLink.no.

Photo showing the south facing structural frame at Voll research fields. Voll AWS is seen to the left. Photo © Majbrit Hirche.

Opposite side. The location of the claddings at Voll research fields. The compass directions as well as the normal direction of the two structural frames are shown.

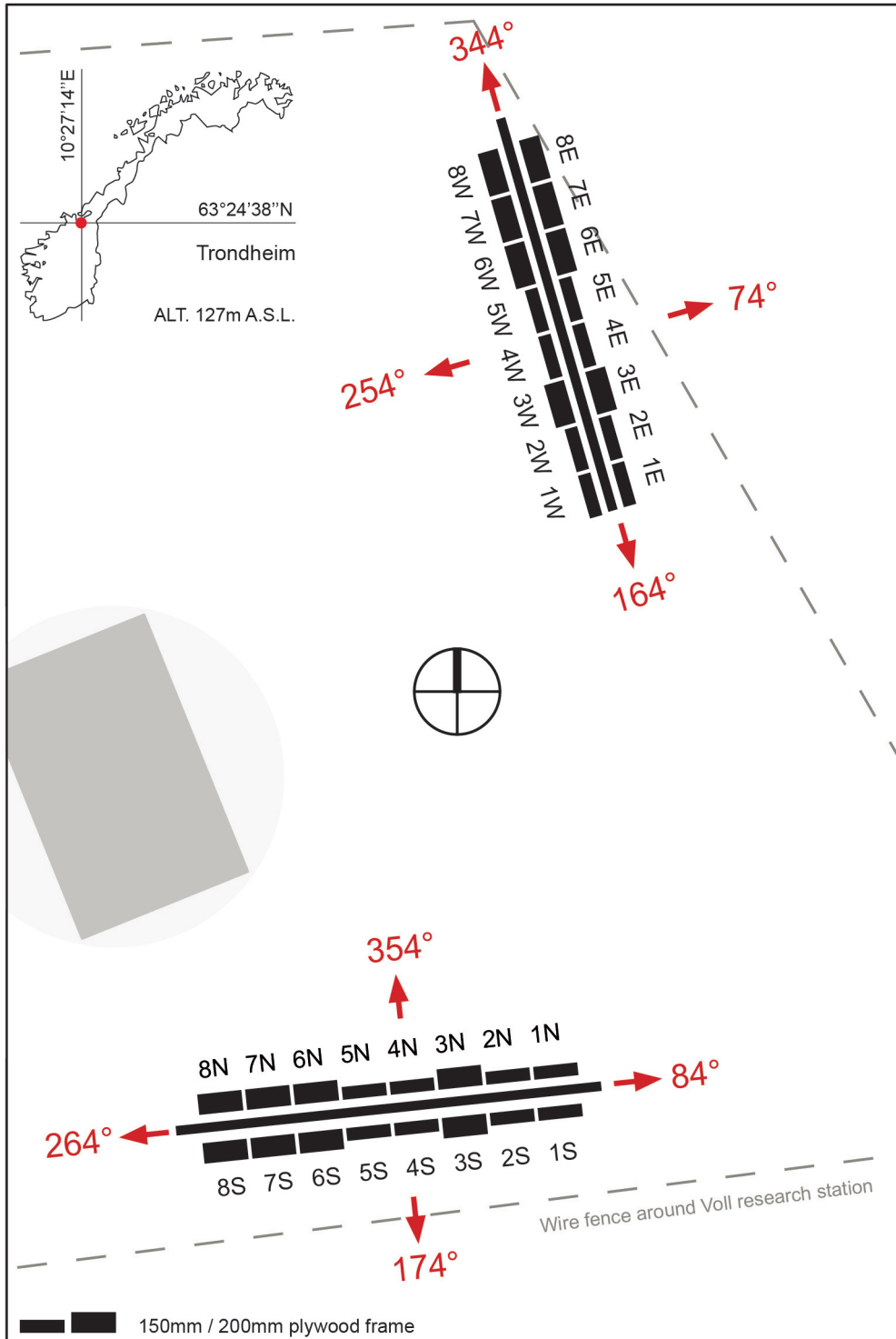



The size of the unscanned area is approx. 30-35mm

Cross-section of Sample 2S and the location of the scanned surfaces shown above.

Figure 3.33 The scanning and post-processing process of the weathered surfaces. Here exemplified for Face 2 of Sample 2S. Each half of the board surfaces were scanned and the two halves merged into one image. The brown left side area of these surfaces is invisible in the assembled Cladding 2 and therefore removed in the post-processing.

3.4 Developing tools for analyzing the weathering of the experiments

It was expected that there would be variations in the weathering color development among the four samples of identical claddings. The weathering color development of Cladding Number 2 caught special attention. The surfaces of Sample 2W appeared all grey and it seemed that the grey color process was highly advanced. The surfaces of Sample 2N and 2E appeared still brownish with a light grey tone indicating that these samples were developing grey at a slower rate compared to Sample 2W. Sample 2S had a remarkable asymmetry in the color development characterized by a repeated pattern of brown and extractive deposits on the left side corners (Face 4 and left edge of Face 1) and dark grey on the remaining surfaces. The color pattern of Cladding 2 can be seen in Chapter 4 Fig. 4.10 and Figs. 4.14-4.17.

Based on the knowledge that the grey color is created by surface fungal growth and that the growth requires water, it seemed that growth conditions for grey color fungi were indeed very favorable on the surfaces of Sample 2W. Growth conditions seemed less favorable on the surfaces of Sample 2N and 2E since the graying was very light compared to Sample 2W. On the surfaces of Sample 2S it seemed that conditions were favorable on the south and west facing surfaces (Faces 1, 2 and 3) whereas growth conditions on the east facing surfaces (Face 4) were not favorable at all except at the end grain area at the bottom of the board. However, the presence of extractives on Sample 2S Face 4 indicated exposure to water in some form.

These early observations of the color development of particularly Cladding Number 2 indicated significant variations in the weather towards the four compass directions in the experimental setup:

- West and south facing surfaces were apparently exposed to larger amounts of precipitation compared to surfaces facing other compass directions. This was consistent with information available on the prevailing wind-driven rain (WDR) direction at the Voll research fields; the main WDR direction is west by south west (Geving, S. et al. 2006).
- The asymmetry of the color pattern of Sample 2S indicated that this sample was facing two different types of weather. The west and south facing surfaces (Faces 1, 2 and 3) seemed to be exposed to a wet type of weather and presumably faced the main WDR direction at Voll. The east facing surfaces (Face 4) seemed to be exposed to a more dry type of weather.

The observations also indicated some inconsistency from current guidelines that north facing surfaces develop grey color faster than surfaces facing other directions (Larsen, K.E. and Mattsson, J. 2009). It rather seemed that facing the direction of the main wind-driven rain was the determining factor in the rate of the graying processes.

In order to understand details of the variation, it was decided to do a separate study of the local weather at Voll to support the analysis of the weathering color development

of the claddings. The study of the Voll weather resulted in three different types of weather maps that illustrate the main tendencies in the occurrence of rain and sun at Voll as these two weather elements are the principal factors causing the wooden surfaces to change color as discussed in Chapter 2.

The maps were especially designed to support the analysis of the weathering color development of the claddings in this project. The three types of maps are termed

- Directional Weather Map
- Spherical Weather Map
- Surface Weather Map

A description of the modeling and calculation methods is found in Appendix C. The following is a description of the maps and how they are used in the analysis of the color development of the claddings in this experiment.

3.4.1 Directional Weather Map

The directional weather map was designed to give a fast overview and an intuitively easily understanding of the in-situ weather situation at any given site, in this case Voll. The advantage of the visualization in a polar diagram, as opposed to the often used bar charts, is that the information is easily transferable to the view of the horizon when observing in the field, as well as to the projection of a situational plan. The weather elements, in this case wind-driven rain, sun and UV hours can be displayed individually as shown in Fig. 3.34 or combined in the same polar diagram as shown in Fig. 3.35. The advantage of a combined diagram is that it allows for an immediate overview of the weather combinations in the total sector. The drawback of the combined diagram is that the radial scale has different values for the different weather elements.

Principles in the calculation method for wind-driven rain curve

Traditionally, a bar chart type histogram with a linear direction-angle x-axis has been used to visualize the exposure of plane vertical surfaces to wind-driven rain. Each bar in this histogram represents the amounts of WDR collected on a vertical surface facing the direction of the bar's x-axis value. As a vertical surface collects WDR from an angular section of 180°, the traditional histogram is badly suited for visualizing the WDR exposure of a three-dimensional façade cladding with a narrower directional opening e.g. Cladding Numbers 2 and 3 in this project. Further, the linear arrangement of the directions on the x-axis is not intuitively transferred to the circular horizon in a field observation or to the projection of a situational plan.

To obtain a more detailed and transferable visualization of the angular distribution of wind-driven rain, the directional weather map was developed as a polar histogram with each bin spanning 10°. Each 10° bin represents the average annual sum of WDR associated with rain events with wind direction within the direction interval of the bin as collected by a surface directly facing the wind direction. In this way, the directional weather diagram mimics the histogram resulting from a directional binning of the WDR

amounts collected by a rotating WDR gauge. As an example, the 10° bin of the directional weather map centered around 180° accumulates the WDR amount from rain events with wind direction within the interval $175^\circ - 185^\circ$. In contrast to this, the bar at 180° in the traditional WDR histogram accumulates rain events with wind direction within the much larger interval $90^\circ - 270^\circ$, but with a weighting of the contribution of each event according to incidence angle, i.e. the angle between wind direction and the surface normal direction.

Data for calculating the WDR comes from the Voll automatic weather station (AWS), located at the Voll testing field. The location of the Voll AWS is shown on the aerial photo Fig. 3.32. The data used are logged in free field, hence the WDR diagram illustrates the tendencies of the WDR in the sky above Voll. This calculation method must not be confused with calculations of an actual load of wind-driven rain on an actual vertical surface.

Principles in the calculation of directional sun and UV hour curves

The solar path is well known and a few common rules can readily be applied to make a rough estimate of the intensity of the sun relative to the cardinal compass directions, the altitude and to the inclination of a surface. However, it was found useful to try developing a method for visualizing the solar path in a way that was relevant to this study. The solution was to calculate the total annual amount of hours the sun is above the horizon and to display a curve showing the amount of sun hours for every 10° sector, similar to what was done with the wind-driven rain curve. The distribution of sun in each 10° sector was calculated as the total annual amount of hours the sun is above the horizon in any given sector at Voll. The model does not account for cloud covering of the sky hence assuming a permanent clear sky.

In order to illustrate the number of sun hours responsible for the strongest effect on the wooden surface, the UV part of the solar spectrum, a separate curve was calculated displaying an estimate of the number of UV hours, i.e. the solar hours multiplied by UV atmospheric extinction coefficient. For this calculation, a simplified homogeneous atmospheric model was applied to account for the extinction of the UV solar radiation. Note that the radial circles in the sun and UV curves represent different values in Fig. 3.34.

The directional weather map was used to aid the analysis of the color development of the claddings. This was done by positioning drawings of the horizontal sections of the claddings rotated to compass directions corresponding to the actual location at Voll. The direction of the surfaces was compared to the WDR, sun and UV curves in the sectors opposing the surfaces. In this way it was possible to see the main trends in the weather corresponding to the individual surfaces in a cladding and to evolve a probable explanation for the color development. For instance, in the case of Cladding Number 2S, it seems probable that Face 4 developed brown due to exposure to high amounts of sun hours and absence of direct exposure to WDR, whereas Faces 1, 2 and 3 developed grey as a result of exposure to WDR. The directional weather maps corresponding to Sample 2S can be seen in Fig. 4.12.

3.4.2 Spherical Weather Map

The Spherical Weather Map is designed to give an overview of the mean annual distribution of rain on the hemisphere above Voll. The purpose of this map is to introduce a three-dimensional type of visualization of wind-driven rain that complements the directional weather map which visualizes weather from the direction of the horizon only.

The distribution of rain is calculated from the height and azimuth angles of the falling raindrops. Each rain event is placed in a grid of angular cells measuring 10° in the horizontal plane and 10° in height angle forming a total of 324 cells in the spherical grid.

3.4.3 Surface Weather Map

The Surface Weather Map is designed to visualize the distribution of WDR as well as sun and UV hours on the individual surfaces of claddings.

The program designed for modeling the WDR surface weather map combines the information in the spherical weather map with the actual geometry of a cladding. As is the case with the directional and spherical maps, the data used for generating the WDR maps are logged in free field and therefore the surface weather maps displays a situation where WDR is not influenced by any physical object. In the present calculations, the trajectories of rain drops are treated as straight beams.

The visualizations of the sun and UV hours follow the same principles as described in the directional weather map for sun and UV hours. The surface weather maps for sun and UV hours do not visualize the actual exposure conditions but simulate the maximum possible number of hours a surface in any given direction and under any given shade conditions can be exposed to at Voll. This information is a measure of an exposure potential that serves as a reference for comparing the sun and UV distribution on the individual surfaces in a cladding as well as among the other samples in the experiment.

In an initial version of the modeling of the surface maps, a linear scale was used. This was later changed to a logarithmic scale. In the linear scale, information on the lowest amounts of WDR, sun and UV hours was lost. The use of a logarithmic scale was an important improvement in the calculation and modeling methods since it allows for detecting nuances on surfaces exposed to very low amounts of WDR, sun and UV hours, as seen for instance on the north-facing surfaces. The nuances in the upper range of the scale displaying the highest amounts of exposure to weather are lost in the logarithmic scale.

There are two advantages of visualizing the low range in the logarithmic scale at the expense of visualizing the upper range of the scale. Information on exposure to very low amounts of WDR is important in understanding why some surfaces develop grey at a very slow rate. The time of establishment and growth of dark walled fungi depends largely on the amounts of WDR as discussed in Chapter 2. Information on surfaces exposed to very low amounts of WDR, sun and UV is an important factor in assessing the time aspect of weathering.

Displaying the lowest amounts of WDR, sun and UV hours also allows for distinguishing between areas of a cladding that are fully shaded and therefore not exposed to direct weather from those areas that are exposed to very low amounts of weather. This information is particularly valuable for the understanding of the grey color development. It seems of less importance to the study of weathering color development to be able to distinguish between exposure to high and very high amounts of WDR, sun and UV hours. However, it could be of interest for studies of wood durability to visualize details of the exposure conditions in the upper range of the scale.

Visualizations of WDR, sun and UV hours were made for all surfaces in the claddings in the experiment. The shading effect of the protective plywood frame was included in the calculations. In order to facilitate the best and most intuitively easy transfer of information on the modeled surfaces to the weathered surfaces in the experiment, the images are displayed in sizes comparable to the individual boards. The surface weather maps are shown in Chapter 4 together with the scanned surfaces.

The surface weather maps were used to support the analysis of the weathering color development of the claddings. The surface weather maps, directional and WDR spherical maps support each other mutually in characterizing the overall weather in-situ conditions as well as providing valuable information on the probable exposure conditions of the wooden surfaces in this experiment.

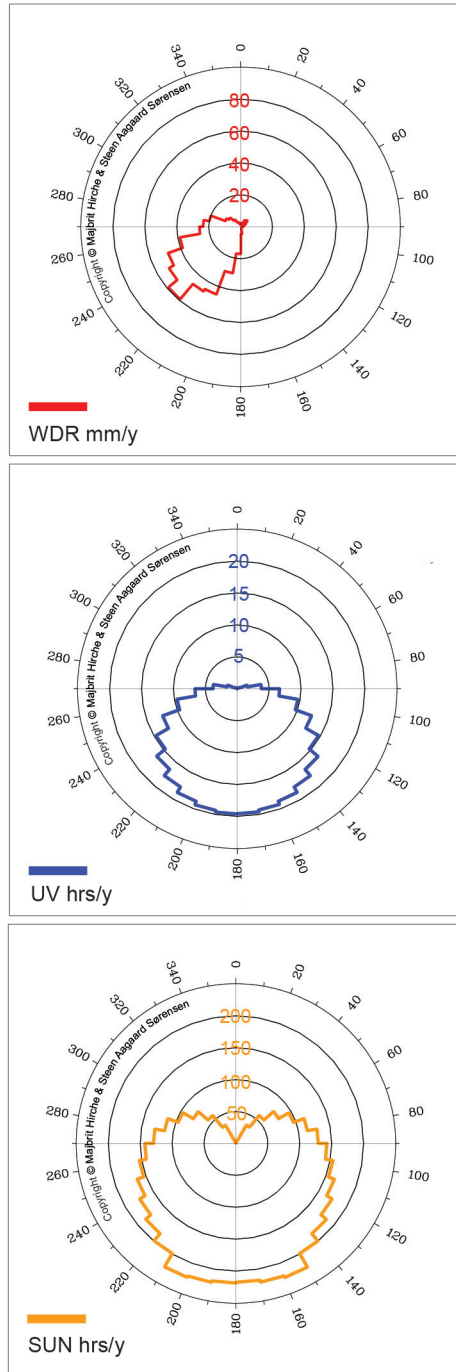
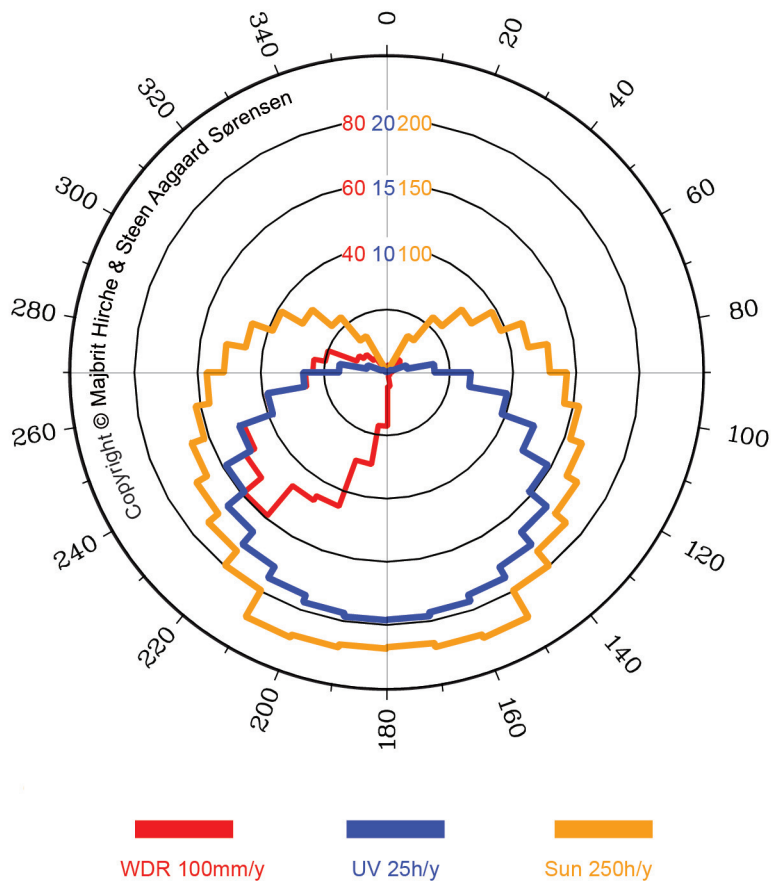
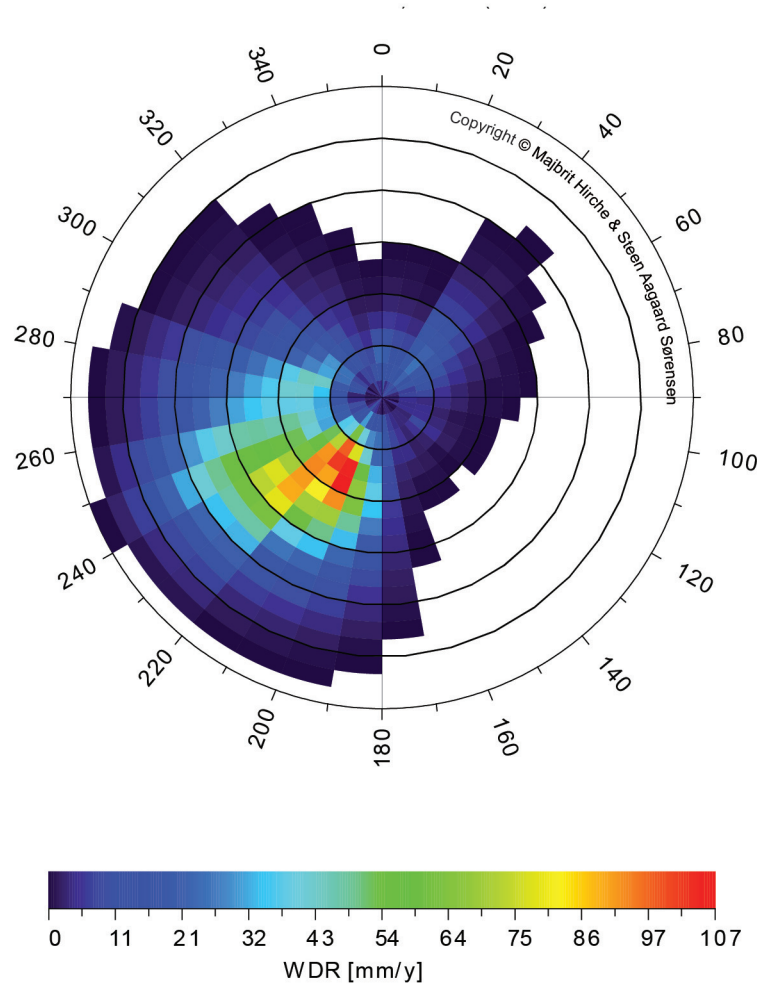

Figure 3.34 The directional WDR, UV and sun hour weather maps for Voll.



MAX. RADIAL VALUE	WDR 100mm/y	UV 25h/y	Sun 250h/y
LOCATION	VOLL/ TRONDHEIM/ NORWAY		
LAT.	63°24'38"N		
LONG.	10°27'14"E		
ALT.	127m A.S.L.		
CLIMATE STATION	Voll AWS # 68860 (WMO # 01257)		
DATA ACQUISITION PERIOD	1999 - 2006		
MEAN PRICIPATION	785mm/y		
SOURCE	WWW.EKLIMA.NO		

Figure 3.35 The directional WDR, UV and sun hour weather maps combined into one diagram.



RADIAL VALUE RANGE	90° Zenith (center) — 0° Horizon (outer circle)
LOCATION	VOLL/ TRONDHEIM/ NORWAY
LAT.	63°24'38"N
LONG.	10°27'14"E
ALT.	127m A.S.L.
CLIMATE STATION	VoII AWS # 68860 (WMO # 01257)
DATA ACQUISITION PERIOD	1999 - 2006
MEAN PRICIPATION	785mm/y
SOURCE	WWW.EKLIMA.NO

Figure 3.36 The WDR spherical weather map for Voll.

4 Results and Discussion

4.1 Method for analyzing the color development of the claddings

The analysis and discussion starts with a characterization of the main tendencies of weather in terms of the four experimental directions at the Voll research fields as suggested by the directional and spherical weather maps.

There follows an analysis and discussion of the color development of the claddings in order of sequence, beginning with the four samples of Cladding 1. The analysis is structured in three parts. First there is an identification and description of the weathering color pattern of the samples, then an analysis of the color development, and finally comments on edge effects where they are present. The analysis focuses on understanding the color development through the interactions of cladding design, weather exposure and the wood surface reactions to weather.

4.1.1 Identification and description of the weathering color patterns

The identification of weathering colors and color patterns by means of the author's visual interpretation of the scanned images, rather than quantitative measurements, introduces the potential problem of subjectivity. In order to mitigate any inherent bias, the total set of data is displayed. Presentation of a common reference set allows the reader to evaluate details in the color development, and if so desired, derive own conclusions in parallel with the analysis presented in this work.

Defining the level of detail in the color description and analysis turned out to be challenging. The high resolution color documentation obtained through the method of scanning the surfaces reveals a very large number of color nuances. A satisfactory strategy had to be developed to determine what to include and what to omit from the description. A first attempt was made to establish and name a number of color categories based on a qualitative assessment of the color values. However, this turned out to be difficult since the color nuances numbered in the hundreds, if not thousands, of values. It should be reasonably straight forward to eventually design a program that can identify and categorize colors based on the digital images. In this work though, a simplified approach of identifying and naming the weathering colors was used: colors that appear grey to the human eye are simply termed "grey". Adjectives like "lighter" and "darker" are used when comparing color nuances. Likewise, colors that appear brown are simply termed "brown", with nuances qualified by "lighter" or "darker" brown. Extractives are termed "extractives" or "extractive deposits". Note that in some instances

it is not possible with the present set of data to determine whether a brown color represents light induced chemical processes, or extractive deposits, or a combination of the two. Knots appear as brown areas of varying form and size scattered over the surfaces. The colors of the knots are not discussed in this work.

Identification of the weathering color patterns of the samples was done by placing the scanned board surfaces side by side in the same order in which they had been positioned in the cladding during weather exposure. In the display of the results, three pattern units, taken from the central area of each cladding, are shown, and the color patterns described. Note that the scanned surfaces of Cladding 2 and 3 are of slightly varying lengths due to the minor gap in the registration at the middle of the vertical boards as discussed in Section 3.3.3. The upper edges of the assembled surfaces appear irregular instead of the straight line that would be expected had the boards been of the same lengths.

A number of boards turned out to be of mixed heartwood and sapwood. The color pattern identifications are based on the heartwood color. The sapwood parts of the boards are identifiable as clearly darker grey areas compared to neighboring tissue of the same surface. Where the presence of sapwood was suspected, the boards in question were compared to corresponding frottage images showing the annual ring pattern. In this way it was possible to see if the area of suspected sapwood was located towards the pith or bark side of the boards in question. The frottages are shown in Appendix B.

Where sapwood is clearly visible, it is noted in the text. Note that sapwood may be present in a board but not detectable from the present set of data.

4.1.2 Analysis of the color development

The analysis of the color development is based on knowledge of wood surface reactions to precipitation and solar radiation as described in Chapter 2. The emphasis is on the effect of precipitation in the form of rain, since the color grey that originates from the water-induced biological processes is easy to identify with the naked human eye. The distinct identification of the effects of solar radiation requires a type of data that is not available in this work. The brown color development could be interpreted as the result of solar induced chemical processes or extractives emerging on the surface. For the analysis of the color development, the scanned images are displayed in groups of the individual surfaces.

The directional, spherical and surface weather maps are used to establish a probable connection between weather exposure and the color development of the surfaces. One directional and one spherical weather map are shown for each of the individual surfaces in a cladding. A horizontal section of the cladding, with an indication of the specific surface, is shown together with each of the maps. The horizontal sections are rotated to a position corresponding to their orientation at the Voll research field. In the weather maps, areas that correspond to the angle openings of the individual surfaces are illustrated with a white background color, whereas areas of the sector that is outside the angular opening are masked with a transparent color. This visual display allows for an intuitively easy identification of the weather in the sectors

corresponding to the individual surfaces, as well as illustrating weather that is not likely to affect the surfaces. A surface weather map is modeled for all surface types in the claddings.

4.1.3 Deviations from the color pattern repeat

Some of the samples have developed deviations from the dominant color pattern repeat. In order to understand the origin of colors that are not readily explainable, causes are looked for in the experimental design. It is clearly recognized that the plywood protective frame has played a role in the color development on some of the samples. This aspect is discussed where relevant in relation to the analysis of the samples.

As mentioned above, a number of boards contain sapwood. This had already become clear during production of the claddings, when the surfaces were planed. Upon exposure to water the sapwood tissue became clearly distinguishable from the heartwood since, due to the low concentrations of extractives, sapwood develops grey color at a significantly faster rate than to heartwood. The consequence in terms of weathering is that a number of samples appear distinctly two-toned grey. Had the samples been made of heartwood only, as was intended, the visual appearance of the grey colored surfaces would have been more uniform.

During the experimental period and prior to the color registration of the claddings, a problem occurred with the east-west facing experimental supporting frame. The prevailing western winds at the Voll research field had caused this frame to bend approximately 7° towards the east. Fig. 4.1 shows a photo of the inclined frame prior to restoration to vertical and the location of the claddings that were possibly affected. The bending was primarily at the southern end of the frame, potentially affecting samples 1W, 2W, 3W and 1E, 2E and 3E. The problem most likely occurred during the thaw in the spring of 2007, and was detected and repaired on July 7th, 2007. The possible effects of this bending on the claddings could be exposure to higher or lower amounts of WDR and solar radiation on the west and east facing claddings respectively than would have been the case if the claddings had been exposed in the intended vertical position. With the prevailing weather conditions towards these two experimental directions, the west-facing claddings could have developed darker grey whereas the east-facing claddings could have developed lighter grey than would have been the case had the claddings been exposed in the intended vertical position.

The four samples of Cladding 7 were removed from the experiment. It is suspected that these may have been mistakenly mixed up during inspection of the samples, possibly with 7W being placed at the location of 7E and vice versa. Removing the samples fully mitigates the risk of incorrect conclusions being drawn as a result of experimental error.

4.1.4 Display of the scanned images

The scanned images are displayed in a small and a large scale version. The small scale images are assembled as the pattern repeat as well as in groups of the individual board

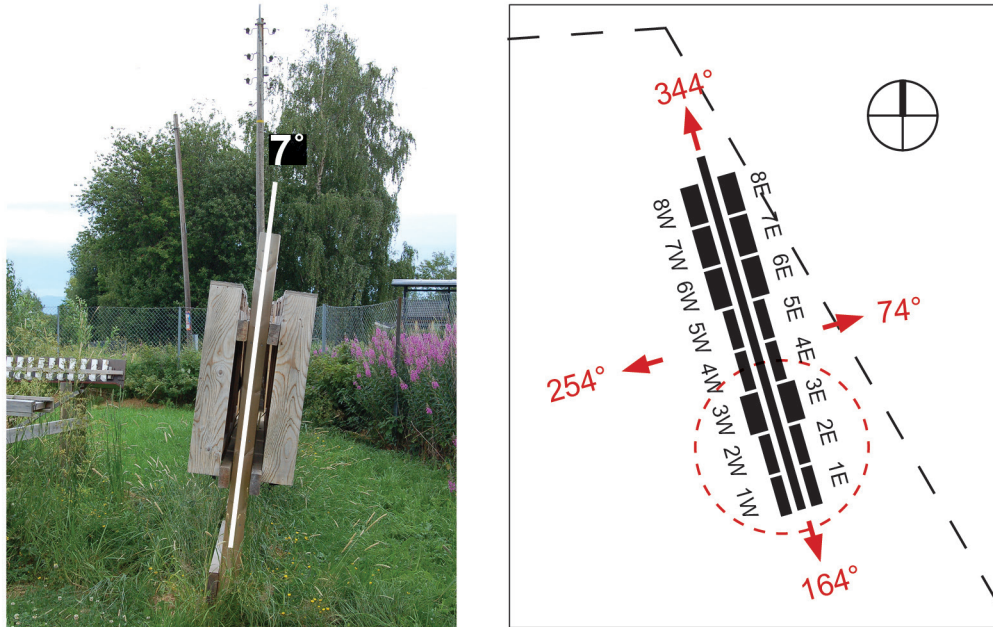

Figure 4.1 Left. Photo showing the tilted east-west facing supporting frame leaning approximately 7° towards east. Photo © Majbrit Hirche.

Right. The samples that were possibly affected by the change in exposure conditions due to the tilted supporting frame are shown in the red circle.

types. The small scale display shows the main tendencies in the color development and facilitates the color comparison of the four samples of a cladding type. The large scale version facilitates the study of details in the color development. The individual surfaces of all samples are individually numbered and the numbers are used as a reference throughout the text.

4.1.5 Photos taken after five years of exposure

Photos taken after five years of weather exposure are included in this material and shown in Fig. 4.60. The photos give valuable information on the color development at a late stage of weathering. The information was particularly useful when analyzing surfaces of which the color development was difficult to interpret due to slow-developing colors. In addition, the photos were used to understand the influence of the plywood frame on the color development. Note that the photos were taken on location at Voll with the samples mounted on the supporting frames and under the prevailing daylight conditions, moisture content and shade generated by the geometry of the claddings. This prevents direct comparison of the colors in the photos with the samples and the scanned images. Still, the photos clearly show the main tendencies in the color development after five years of exposure.

4.2 Characterization of weather towards the four experimental supporting frames at Voll research fields

The directional and spherical WDR maps Fig. 4.2 show the weather impacting the four experimental supporting frames at the Voll research fields. The claddings mounted on the four frames are exposed to weather from four different 180° sectors as illustrated in the maps. The white area of the maps illustrates weather in a 180° sector opposing the frames, whereas the 180° sector masked with a transparent layer illustrates weather incident on the rear side of the frames. The weather from the 180° sector opposing a supporting frame contributes to weathering of the claddings mounted on the frame, whereas weather behind the frame does not contribute.

The four 180° sectors corresponding to the four directions of the experimental supporting frames have the following angular ranges on the horizon:

- 264°–84° for the north-facing frame
- 84°–264° for the south-facing frame
- 344°–164° for the west-facing frame
- 164°–344° for the east-facing frame

The maps demonstrate that there are significant differences in the weather incident on each of the four experimental frames in terms of the amount of WDR, UV and sun hours. The main WDR direction at Voll research fields is located in a sector from approximately 180°–270° at the horizon with the highest amounts at around 220° azimuth.

The west-facing and south-facing frames are oriented towards the main WDR direction

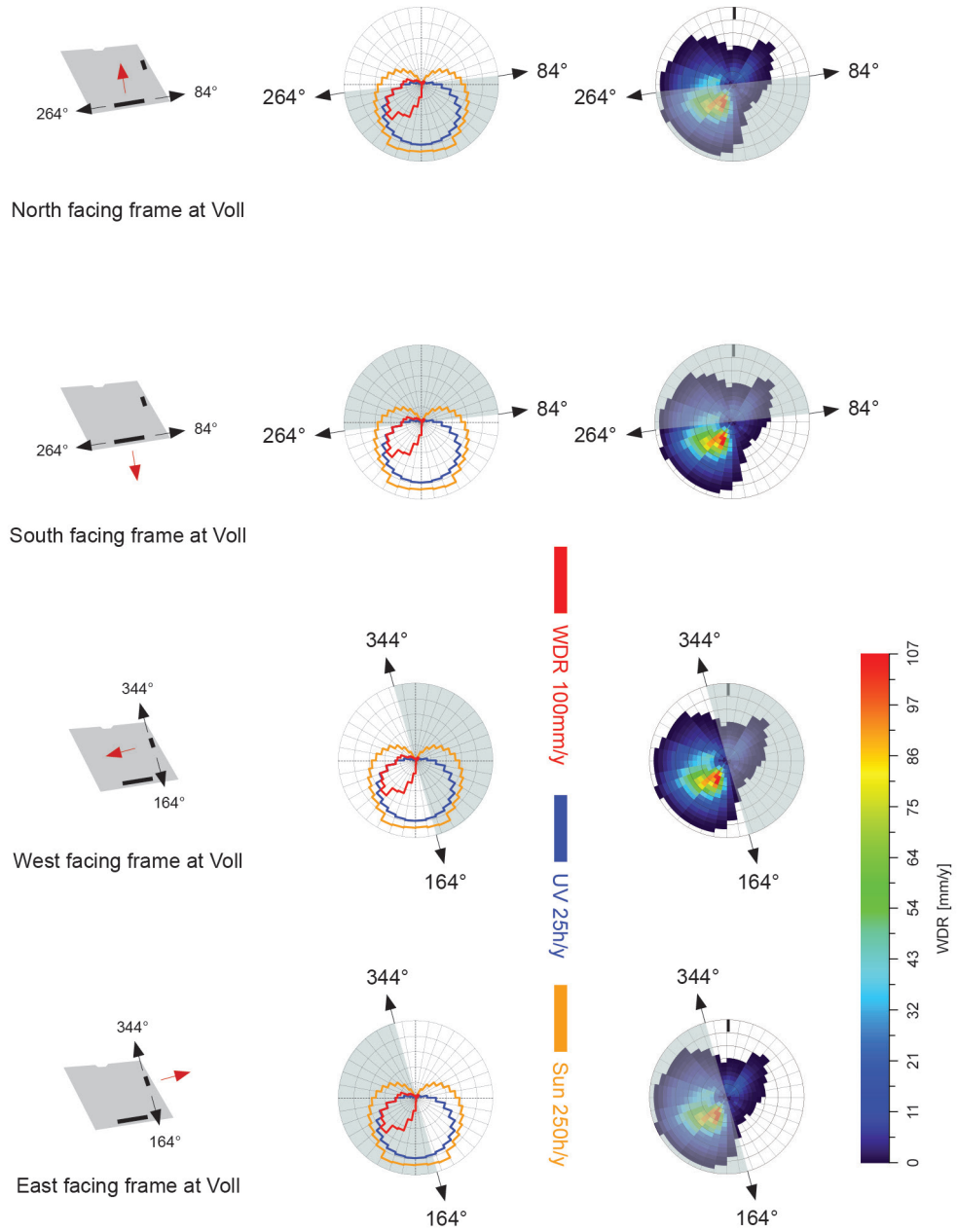

Figure 4.2 The directional and spherical weather maps showing the weather incident on the four supporting frames at the Voll research fields.

at Voll, whereas the north-facing and east-facing frames are oriented towards areas of the horizon outside the main WDR direction. The amounts of UV and sun hours in the Northern Hemisphere are highest towards the south, and lowest towards the north. The amounts of UV and sun hours towards the west-facing and east-facing frames would have been identical had this frame been orientated directly towards the cardinal compass directions. However, due to the 16° offset of the frame towards the west, the amounts of UV and sun hours are slightly higher on the west-facing frame than on the east-facing frame. The amounts of UV and sun hours incident on the west-facing and the east-facing frames are roughly half of the amounts incident on the south-facing frame.

The distribution of WDR on the sky as illustrated by the spherical weather maps suggests that the highest amounts of WDR comes from an area of the sky located at approximately 190° - 250° azimuth and 45° - 75° height angle (the red, orange, yellow and green colored areas). Very low amounts of WDR falling at high angles are found in the eastern sector from approximately 340° - 160° azimuth angle.

A series of photos Fig. 4.3 of all samples were taken at the Voll research fields on a winter's day, January 17th, 2007, when the samples were covered in snow. The snow deposits in the photos illustrate the main tendencies in the wind direction and consequently also the main tendencies in the distribution of wind-driven rain at Voll.

The north-facing samples have little snow on them. Small amounts of snow have piled up in the left corner of samples 5N, 6N, 7N and 8N. Note that the snow to the left of Sample 4N is piled up on the plywood frame of the neighboring Sample 3N. The small pile of snow in the left corners of the horizontal claddings shows the wind direction towards the north-facing frame.

The south facing samples, except for Sample 1S have snow on them. On samples 4S, 5S, 6S, 7S and 8S the snow has piled up in the right side corners. This demonstrates the direction of the wind towards the south-facing frame.

The west-facing samples are covered in large amounts of snow, except for Sample 1W, which is covered in ice. These samples are facing the main wind direction at Voll.

The east-facing samples have little snow on them. These samples are facing a direction with little wind.

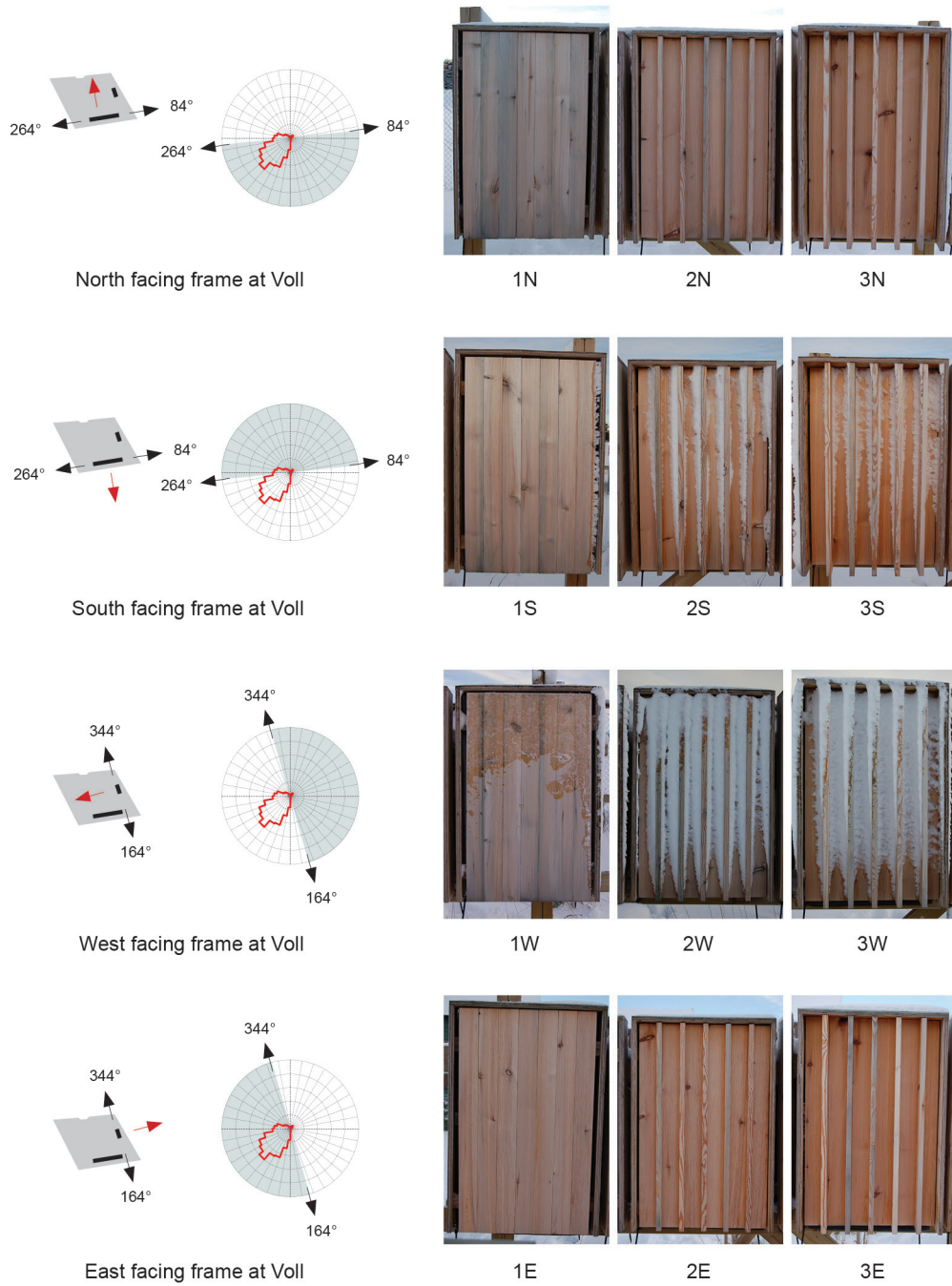

Figure 4.3 Photos demonstrating the main tendencies in the differences in precipitation incident on the four supportive frames. Photos were taken on January 17th 2007. Photo © Majbrit Hirche.



4N

5N

6N

7N

8N



4S

5S

6S

7S

8S



4W

5W

6W

7W

8W



4E

5E

6E

7E

8E

4.3 Cladding 1

Fig. 4.4 shows an overview of the color development of the four samples of Cladding 1. For details of the color development please refer to Figs. 4.8–4.11. Figs. 4.5–4.7 show the weather maps for Cladding 1.

4.3.1 Weathering color pattern

1W is darkest grey, followed by 1S, 1N and 1E as judged by the heartwood part of the boards. All samples of Cladding 1 contain sapwood, which makes the weathering pattern appear two-toned.

Sapwood is present in board numbers 1N1, 1N3, 1N5, 1N9, 1N13+ 1S1, 1S3, 1S5, 1S7, 1S9 + 1W1, 1W3, 1W5, 1W9 + 1E1, 1E3 and 1E7.

4.3.2 Analysis of the color development

Cladding 1 has a non-shaded type of geometry which allows for uniform weather exposure over the total surface area. The directional and spherical weather maps Figs. 4.6 and 4.7 show that the four samples of Cladding 1 were exposed to weather from 180° sectors identical to the sectors opposing the experimental frames.

1W developed darkest grey of the four samples. The surface weather maps, Fig. 4.5, suggest that, of the four samples, 1W was exposed to the highest amounts of WDR, which may explain the fastest dark grey color development of 1W. Due to the tilting of the frame as noted in Section 4.1.3, Sample 1W has possibly been exposed to even higher amounts of WDR thus further accelerating the development of grey color on Sample 1W.

1S developed a lighter grey nuance compared to 1W. The surface weather maps, Fig. 4.5, suggest that 1S was exposed to lower amounts of WDR compared to 1W. This likely caused 1S to develop a lighter grey compared to 1W. In addition 1S was exposed to very high amounts of UV and sun hours. This could dry out the surface of 1S at a faster rate compared 1W, resulting in a shorter time with favorable conditions for dark walled fungal growth on 1S compared to 1W. Thus the difference in exposure to UV and sun hours most likely played a part in the grey color differences between 1S and 1W.

1N developed a lighter grey nuance compared to 1S. The surface weather maps, Fig. 4.5, suggest that 1N was exposed to a combination of low amounts of WDR, UV and sun hours. The WDR exposure is significantly lower on 1N compared to 1S yet the grey color of 1N is only slightly lighter than that of 1S. Exposure to low amounts of UV and sun hours slow down the drying process and keeps the moisture content at favorable conditions for fungal growth for longer periods of time compared to sun-exposed surfaces. This condition is typical for north-facing surfaces and known as Time of Wetness (TOW). Hence, very low amounts of UV and sun hours can explain why 1N developed a grey color, despite exposure to very low amounts of WDR.

1E developed a very light grey to brownish color. The surface weather maps, Fig. 4.5, suggest that 1E was exposed to a combination of very low amounts of WDR and high amounts of UV and sun hours. 1E developed a grey color nuance considerably lighter

than the remaining samples. Only the sapwood part of the surface has developed a clearly recognizable grey color tone, as seen on the right side of 1E1. It is possible, that the light greyish nuance that developed after 20 months of exposure is caused by bleaching of the extractives in the heartwood. The combination of low amounts of WDR and high amounts of UV and sun hours kept the surface moisture content very low and retarded the grey color development significantly compared to the other samples. 1E could have been exposed to lower amounts of WDR due to the tilted frame as noted in Section 4.1.3.

4.3.3 Edge effects

Cladding 1 was possibly affected by edge effect from the plywood protective frame. The dark grey color on particularly Sample 1N on the lower part of boards 1N1, and the upper and lower parts of 1N3 and 1N5 is not readily explainable by the presence of sapwood in these boards. This color development could stem from exposure to an indirect water source possibly originating from water run off from the plywood roof.

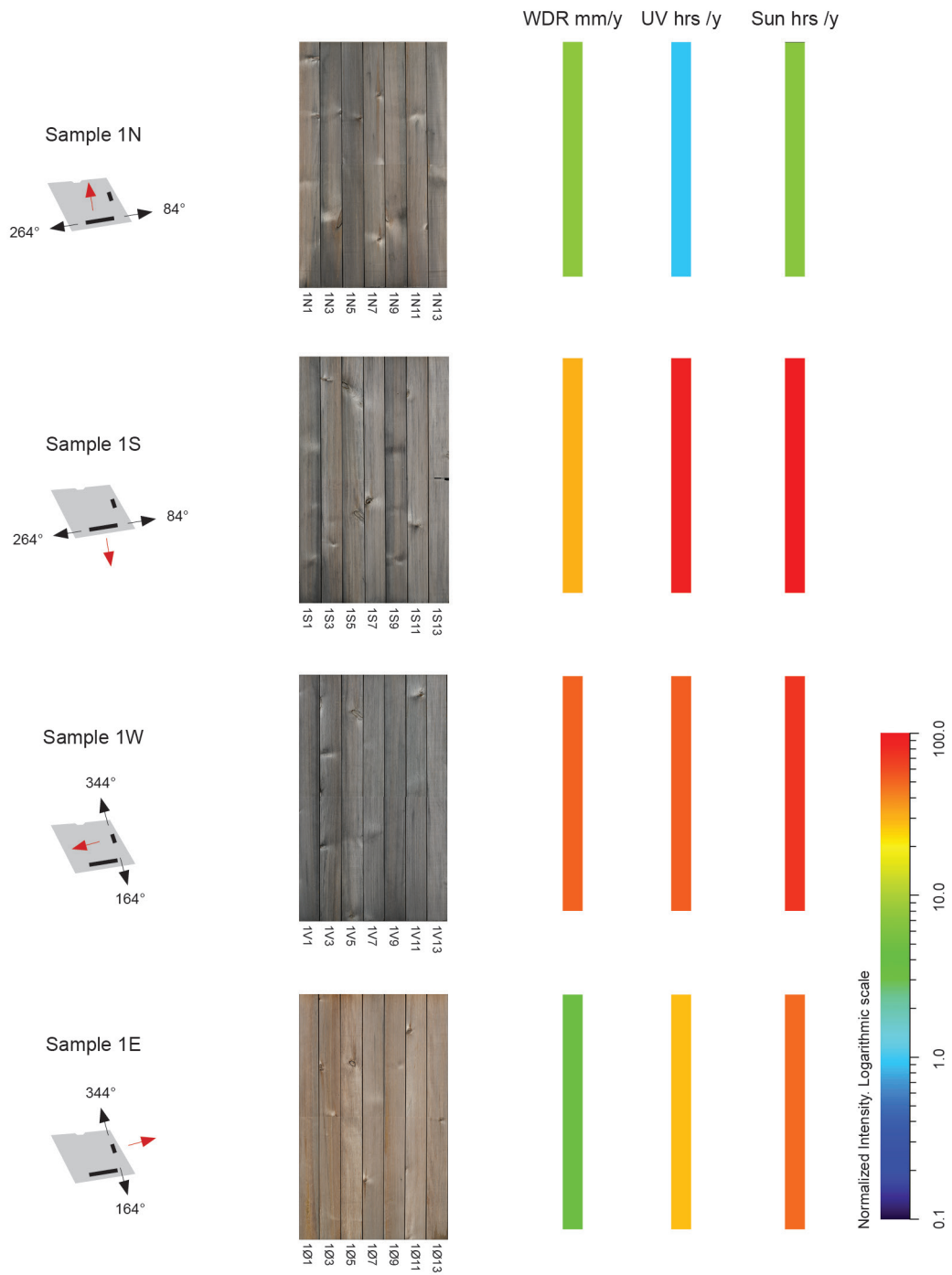

Figure 4.5 Cladding 1. Surface Weather Maps.

Figure 4.4 Cladding 1. Weathering colors of the four samples after 20 months of exposure to weather at Voll research fields in Trondheim.

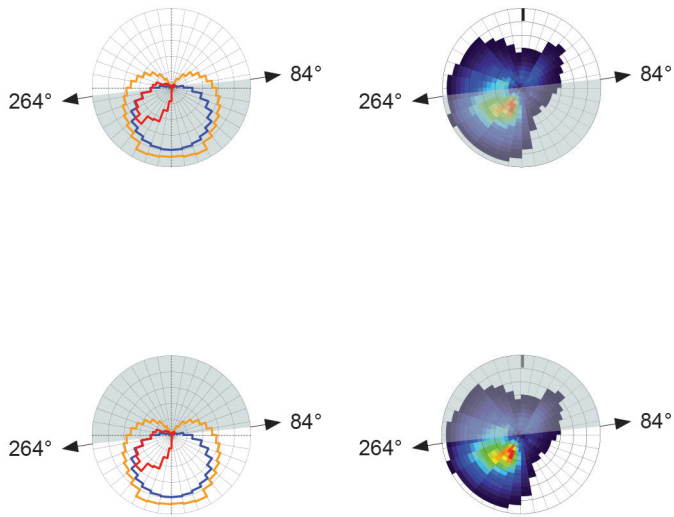

Figure 4.6 Cladding 1.
Directional Weather Maps.

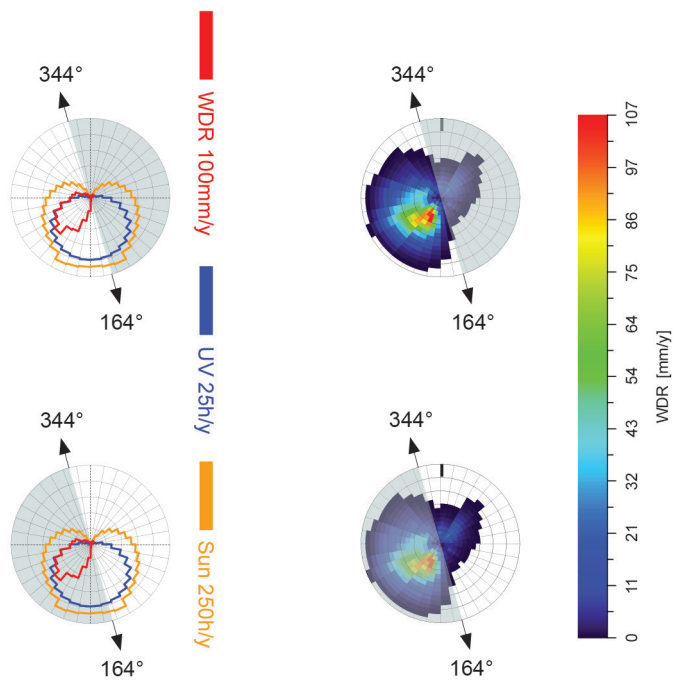

Figure 4.7 Cladding 1.
Spherical Weather Maps.



Figure 4.8 Sample 1N. Color development after 20 months of exposure to weather at the Voll research fields in Trondheim, Norway.



Figure 4.9 Sample 1S. Color development after 20 months of exposure to weather at the Voll research fields in Trondheim, Norway. Note that in the middle section of board 1S13 a small part of the surface was not covered in the scanning process.



Figure 4.10 Sample 1W. Color development after 20 months of exposure to weather at the Voll research fields in Trondheim, Norway.



Figure 4.11 Sample 1E. Color development after 20 months of exposure to weather at the Voll research fields in Trondheim, Norway.

4.4 Cladding 2

Fig. 4.12 shows an overview of the color development of the four samples of Cladding 2 displayed in groups of the individual surfaces and as the pattern repeat. For details of the color development please refer to Figs. 4.16–4.19. Figs. 4.13–4.15 show the surface, directional and spherical weather maps for Cladding 2.

4.4.1 Weathering color pattern

2N has developed a color pattern of light grey on Face 1, light brownish to light grey on Face 2, darker grey on Face 3 and a light brownish to light grey on Face 4 that resembles the color of Face 2. End grain grey is present on Faces 2 and 4, and is most pronounced on boards 2N6E+2N6W, 2N8E+2N8W and 2N10E+2N10W.

2S has developed a two-colored pattern on Face 1 characterized by brown extractive deposits on the left edge and grey color on the right side. Faces 2 and 3 are dark grey. Face 4 is brown with longitudinal streaks of extractives and a repeated pattern of end grain grey.

2W has developed a pattern of grey color on all surfaces with variations in the grey color nuances between the faces. In order of darkest to lightest grey: Face 3 is darkest grey followed by Face 1, the grey color nuance of Faces 2 and 4 appear similar.

2E has developed a pattern of light grey to brownish on Face 1. Face 2 appears brown with a fuzzy pattern of extractives. Face 3 has distinct color differences between early and late wood which appear grey and brown respectively. Face 4 appears slightly darker brown than Face 2.

4.4.2 Analysis of the color development

The surface weather maps, Fig. 4.13 suggest that the four surfaces of each of the four samples were exposed to different amounts of WDR, UV and sun hours.

The directional and spherical weather maps, Figs. 4.14 and 4.15 demonstrate how the four surfaces of this cladding type face different areas of the horizon. Due to the directional differences in the distribution of weather at Voll, the individual surfaces face areas of the horizon with significant differences in the amount of WDR, UV and sun hours.

Face 3

Face 3 of Cladding 2, the foremost surface, has developed darker grey compared to the other faces in the respective samples. Face 3 is a non-shaded surface. The exposure conditions for Face 3 of the four samples of Cladding 2 can be compared to the exposure conditions of corresponding samples of Cladding 1. The clearly darker grey colored Face 3 surfaces are sapwood.

Sapwood is present in boards 2N6+2N8, 2S2+2S6+2S8, 2W2, 2W4 2W8 and 2E2+2E8. The surfaces of Face 3 have distinct color differences between early- and late wood in the heartwood. The low density early wood has developed grey whereas the higher density late wood is still brown. The visually distinct color differences between early- and late wood of Face 3 is due to the tangential cutting pattern that creates

broader bands of the annual rings making the color differences visually more pronounced. On the radial cut surfaces, the color differences between early- and late wood appear less pronounced to the eye.

Assessed by the grey color nuance of the early wood, Face 3 of 2W is darkest grey, 2N and 2S appear rather similar in both the grey color nuance of the early wood as well as the brown color of the late wood. 2E is very light grey in the early wood and still brown in the late wood.

The dark grey color of 2W agrees well with exposure to the highest amounts of WDR facilitating favorable conditions for the growth of surface fungi. By contrast, exposure to a combination of high amounts of UV and sun hours and low amounts of WDR kept the surfaces of 2E Face 3 very dry which resulted in slow growth of surface fungi. Faces 3 of 2N and 2E seem to be developing grey at the same rate. As proposed in the analysis of 1S and 1N, these surfaces developed grey due to exposure to large amounts of WDR in the case of 1S, and in the case of 1N it was argued that long TOW due to low amounts of UV and sun hours facilitated the surface fungal growth. Face 3 of Samples 2S and 2N are exposed to similar weather conditions and the same explanation for the grey color development applies for these surfaces. Due to the small surface area of Face 3, and still clearly visible color differences between early- and late wood in the tangentially cut surfaces, it is less easy to infer a definitive correlation between the weather exposure and the color development of these surfaces.

Faces 2 and 4

Faces 2 and 4 of Cladding 2, the right and left side surfaces, are facing opposite directions of a 180° sector as demonstrated in the surface and spherical weather maps Figs. 4.14 and 4.15. Faces 2 and 4 are shaded by the geometry that creates differentiated exposure conditions characterized by higher exposure on the outermost areas, which gradually decreases towards the rear areas of the surfaces as illustrated in the surface weather maps, Fig. 4.13.

A dark grey color developed on 2S Face 2 and 2W Faces 2 and 4. The surface weather maps, Fig. 4.13 suggest that 2S Face 2 and 2W Face 4 were exposed to high amounts of WDR. The directional and spherical weather maps show that these surfaces were facing the main WDR direction at Voll. The dark grey color development of these surfaces agrees well with exposure to high amounts of WDR which creates favorable conditions for fast growth of dark walled fungi. The surface weather maps, Fig. 4.13 suggest that Face 2 of 2W was exposed to significantly lower amounts of WDR than 2W Face 4, yet the grey color nuances are similar. The directional weather maps, Fig. 4.14 show that 2W Face 2 was facing a sector with significantly lower amounts of WDR than 2W Face 4. The similarly fast grey color development of 2W Face 2 can be explained by exposure to significantly lower amounts of UV and sun hours compared to 2W Face 4. Exposure to low amounts of UV and sun hours could have kept 2W Face 2 at favorable moisture content levels for longer periods of time, resulting in longer periods of favorable growth conditions for dark walled fungi. Another possible explanation for the fast dark grey color development of 2W Face 2 could be raindrop

splash from 2W Faces 1 and 4 deflecting onto Face 2 and resulting in surface moisture conditions similar to those of 2W Face 4.

A light brown to grey color developed on 2N Faces 2 and 4, and on 2E Face 4. These surfaces developed grey at a significantly slower rate compared to the dark grey surfaces discussed above. The photos taken after five years of exposure, Fig. 4.60 show that these surfaces did develop grey over time, however a distinct grey color had not developed after 20 months of exposure. The surface weather maps suggest that 2N Faces 2 and 4 and 2E Face 4 were exposed to a combination of low amounts of WDR, UV and sun hours. The directional weather maps, Fig. 4.14 show that these surfaces were facing north and were turned away from the main WDR direction at Voll. The slow rate of grey color development can be explained by exposure to very low amounts of WDR. These surfaces were also exposed to low amounts of UV and sun hours which is known to prolong the TOW that favor the growth of dark walled fungi. Still, growth conditions for dark walled fungi were significantly less favorable on these north-facing surfaces than on the surfaces which had been exposed to high amounts of WDR.

A brown color with extractive deposits developed on 2S Face 4 and 2E Face 2. The brown color of 2S Face 4 appears darker, and the extractive deposits more pronounced than those on 2E Face 2. The surface weather maps, Fig. 4.13 suggest that these surfaces were exposed to a combination of very low amounts of WDR and high amounts of UV and sun hours. The directional weather maps, Fig. 4.14 show that these surfaces were turned away from the main WDR direction at Voll. The combination of very low amounts of WDR and high amounts of UV and sun hours created surface moisture levels that were too low for visually recognizable colonization of dark walled-fungi. The extractive deposits on these surfaces could have developed during periodic wetting of the surfaces or wetting from rain drop splash. The emergence of extractive deposits on these dry surfaces could also have been influenced by interaction with the WDR-exposed opposite side of the boards, i.e. Face 2 of 2S and Face 4 of 2E. Extractives could have migrated with water from the wet to the dry surface of the protruding boards. In the case of 2S Face 4, the exposure to high amounts of WDR on the opposite Face 2 could explain the fast-developing extractive deposits compared to 2E Face 2. A similar process could have occurred, but at a slower rate in the case of exposure to low amounts of WDR and slower rate of extractive development on the dry side as seen on 2E Face 2. The end grain grey clearly visible on 2S Face 4 can be explained by exposure to high amounts of WDR on 2S Face 2. Some of the moisture may have been taken up by the end grain, resulting in elevated amounts of moisture on the lower part of the otherwise dry Face 4.

Face 1

Face 1 of Cladding 2 is oriented in the same compass direction as Face 3, but the protruding vertical boards narrow down the angle opening towards the horizon as illustrated in the directional weather maps, Fig. 4.14. The surface weather maps, Fig. 4.13 show that Face 1 of the four samples was exposed to significantly different amounts of

WDR, UV and sun hours.

A dark grey color developed on 2W Face 1. The fast dark grey color development can be explained by the surface direction towards the main WDR direction at Voll as shown on the directional and spherical maps, Figs. 4.14 and 4.15. The surface weather maps, Fig. 4.13 suggest that 2W Face 1 was exposed to significantly higher amounts of WDR compared to Face 1 of the remaining samples. Exposure to high amounts of water facilitated fast growth of dark walled fungi as was the case with 2S Face 2 and 2W Face 4.

A clearly lighter grey to brown color developed on Face 1 of 2S, 2N and 2E. Face 1 of 2S also developed extractive deposits along its left edge.

Sapwood seems to be present on the right hand side edge of these surfaces. On 2N and 2E, the sapwood shows as a darker brown color, except for board 2N7, on which it shows as a dark grey edge. On 2S, the sapwood shows as a dark grey right side hand edge. The sapwood tissue appears on corresponding locations of the samples. Sapwood is typically clearly distinguishable from the heartwood when colonized by dark walled fungi. This appears to be the case on the right hand side grey edges of 2S Face 1. The surface weather maps, Fig. 4.13 suggest that 2N and 2E Face 1 were exposed to low amounts of WDR, yet the sapwood did not develop grey coloring, except for 2N7. The color variations on Face 1 of 2N and 2E can be explained by bleaching of extractives in the left hand side heartwood part of the boards, which would visually distinguish the heartwood from the sapwood. The darker grey right side edge of 2N7 is a color deviation from the pattern repeat as are the locally dark grey areas of the lower parts of boards 2N5, 2N7, 2N9 and 2N11. Similar color deviations are found on corresponding surfaces of 2S. It is suspected that these parts of Samples 2N and 2S were exposed to elevated amounts of water coming from the roof of the plywood case. The late stage photos, Fig. 4.60 show that over time the roof developed a downward sloping curve, which could have directed water from the roof to the lower parts of the centrally located surfaces of 2N and 2S. The grey color development of the right hand side area of 2S Face 1 can be explained by exposure to high amounts of WDR, as suggested by the surface weather maps, Fig. 4.13. The surface weather maps also suggest that the left hand side of 2S Face 1 was exposed very low amounts of WDR and high amounts of UV and sun hours. The extractive deposits on the left hand side of this surface can be explained by the migration of extractives from the WDR-exposed right hand side to the drier left hand side area, where they deposited.

The light grey color development of 2N Face 1 can be explained by exposure to low amounts of WDR. It might also, as suggested above, be explained by exposure to light which caused the extractives in the heartwood to bleach and appear greyish. The surface weather maps, Fig. 4.13 suggest that the left hand side of 2N Face 1 was exposed to a combination of low amounts of WDR and sun hours. This could have caused bleaching of extractives as well as some surface fungal growth.

The still very brown appearance of 2E Face 1 can be explained by exposure to very low amounts of WDR in combination with high amounts of UV and sun hours, as

suggested by the surface weather maps, Fig. 4.13. These surfaces faced sectors that were oriented away from the main WDR direction at Voll. Weather towards 2E Face 1 was very dry and colonization of dark walled fungi occurred at a slow rate. The photos taken after five years of exposure, Fig 4.60 show that 2E Face 1 did indeed develop grey, however it was still lighter than Face 1 of the other samples.

4.4.3 Edge effects

The uppermost areas were shaded from direct exposure to precipitation by the plywood roof. The shading effect of the roof is visible on the uppermost areas of the modeled surfaces in the WDR surface weather maps Fig. 4.13. The brown color on the upper most areas can be explained by the absence of exposure to WDR, hence the absence of colonization by dark walled fungi. It is also likely that extractives migrate from the WDR-exposed lower areas to drier areas right below the plywood roof, where they deposit on the surface. The brown color under the plywood roof is clearly distinguishable, whereas the adjacent lower area surface color is grey. This applies to 2N Face 1, 2S Faces 1 and 2, 2W Faces 1, 2 and 4. Where the surface color is predominantly brown, a clearly distinguishable effect from the shading of the roof is not readily observable. This applies to 2N Faces 2 and 4, 2S Face 4 and 2E Faces 1, 2 and 4.

The spherical weather maps, Fig. 4.15 show that precipitation is characterized by low amounts falling at high angles in the sectors corresponding to 2N and 2E. By contrast, precipitation corresponding to 2W and 2S, except for 2S Face 4, is characterized by high amounts of WDR falling at low angles. The roof of the plywood frame may have influenced the access of WDR to the surfaces, particularly of 2N and 2E where the shading effect from the roof is more pronounced when rain falls at high angles. The shading effect of the roof may be less pronounced towards the surfaces of 2W and 2S due to WDR falling at low angles.

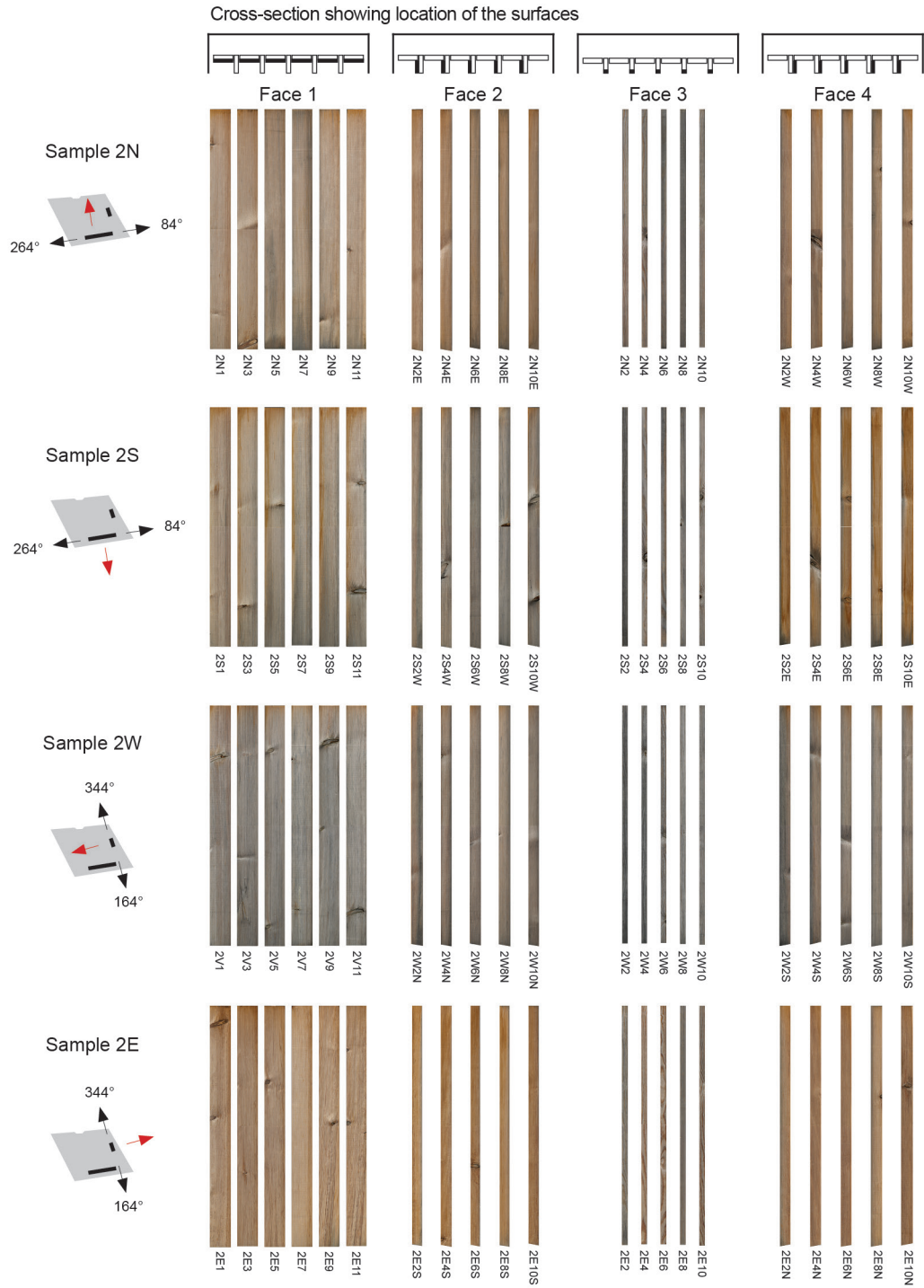

Figure 4.12 Cladding 2. Weathering colors of the four samples after 20 months of exposure to weather at the Voll research fields in Trondheim. The surfaces are displayed in groups of the individual surfaces and as pattern repeat.



Pattern repeat

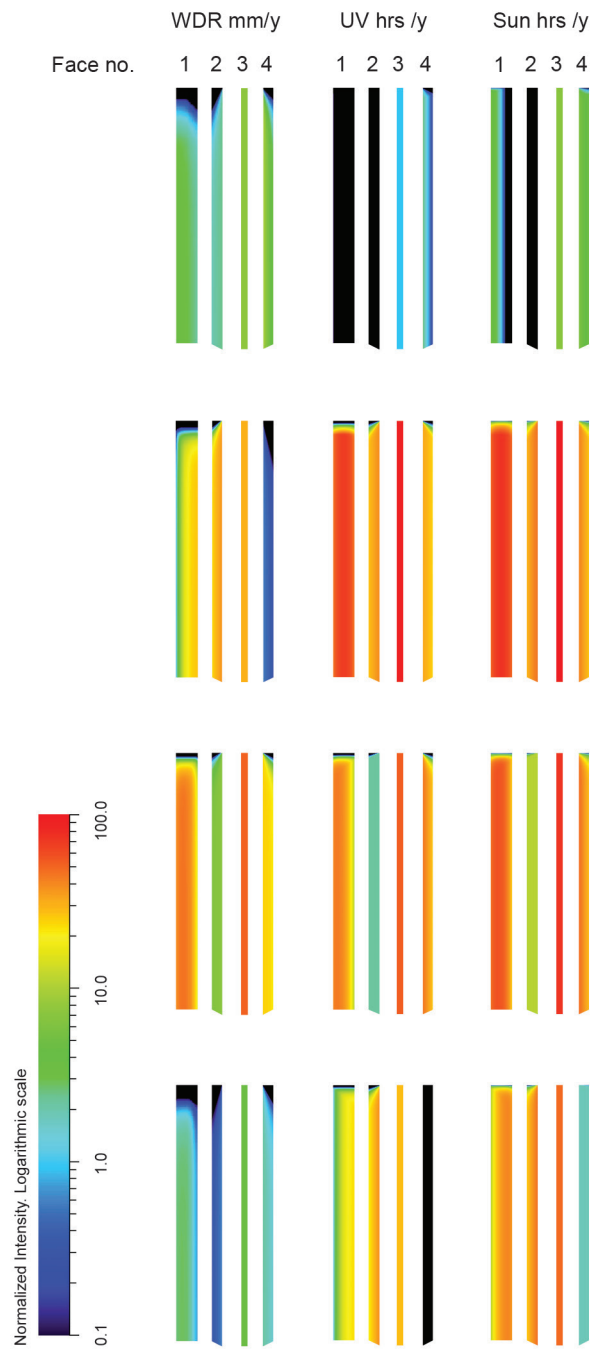

Figure 4.13 Cladding 2. Surface Weather Maps.

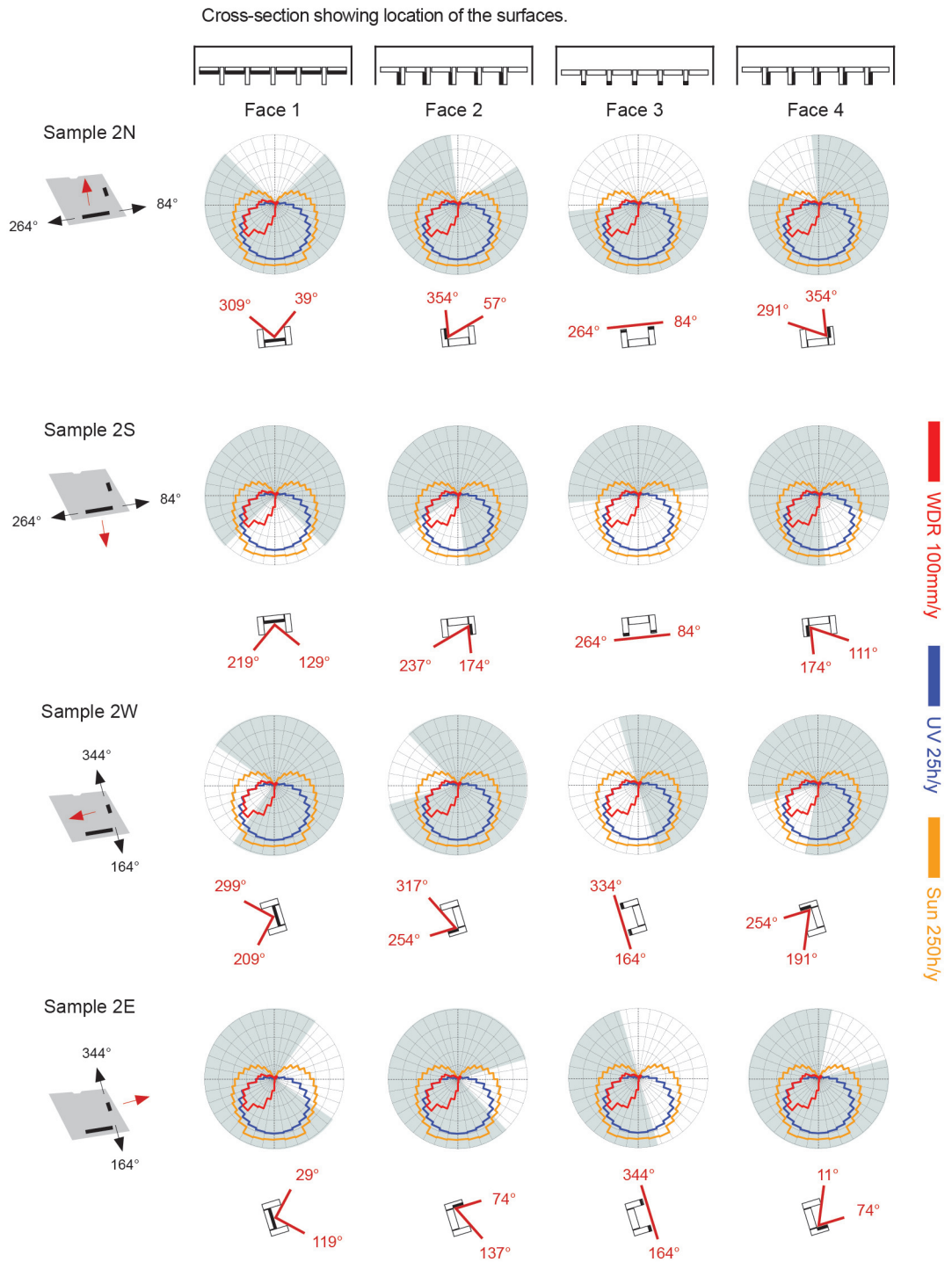

Figure 4.14 Cladding 2. Directional weather maps for the individual surfaces of Cladding 2. The white areas indicate sectors corresponding to the angle openings of the surfaces.

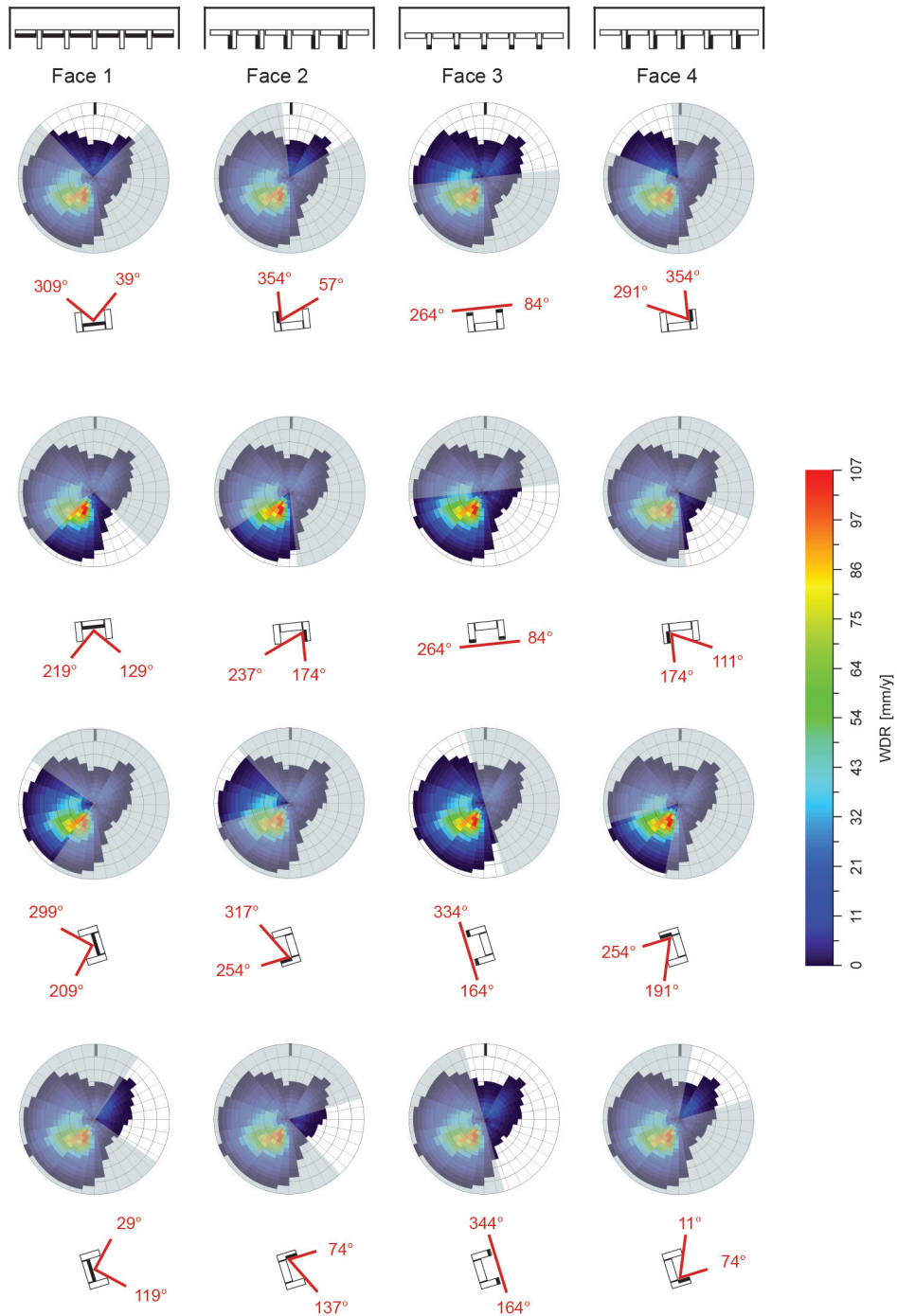

Figure 4.15 Cladding 2. Spherical weather maps for the individual surfaces of Cladding 2. The white areas indicate sectors corresponding to the angle openings of the surfaces.



Figure 4.16 Sample 2N. Color development after 20 months of exposure to weather at the Voll research fields in Trondheim, Norway. From left to right face 1, 2, 3 and 4.



2N2 2N4 2N6 2N8 2N10



Face 3



2N2W 2N4W 2N6W 2N8W 2N10W

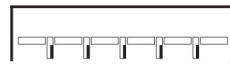

Face 4

Color of the newly planed wood surface





Figure 4.17 Sample 2S. Color development after 20 months of exposure to weather at the Voll research fields in Trondheim, Norway. From left to right face 1, 2, 3 and 4.



2S2 2S4 2S6 2S8 2S10



Face 3



2S2E 2S4E 2S6E 2S8E 2S10E



Face 4

Color of the newly planed wood surface





Figure 4.18 Sample 2W. Color development after 20 months of exposure to weather at the Voll research fields in Trondheim, Norway. From left to right face 1, 2, 3 and 4.

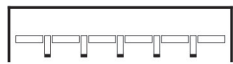

Face 3



Face 4

Color of the newly planed wood surface



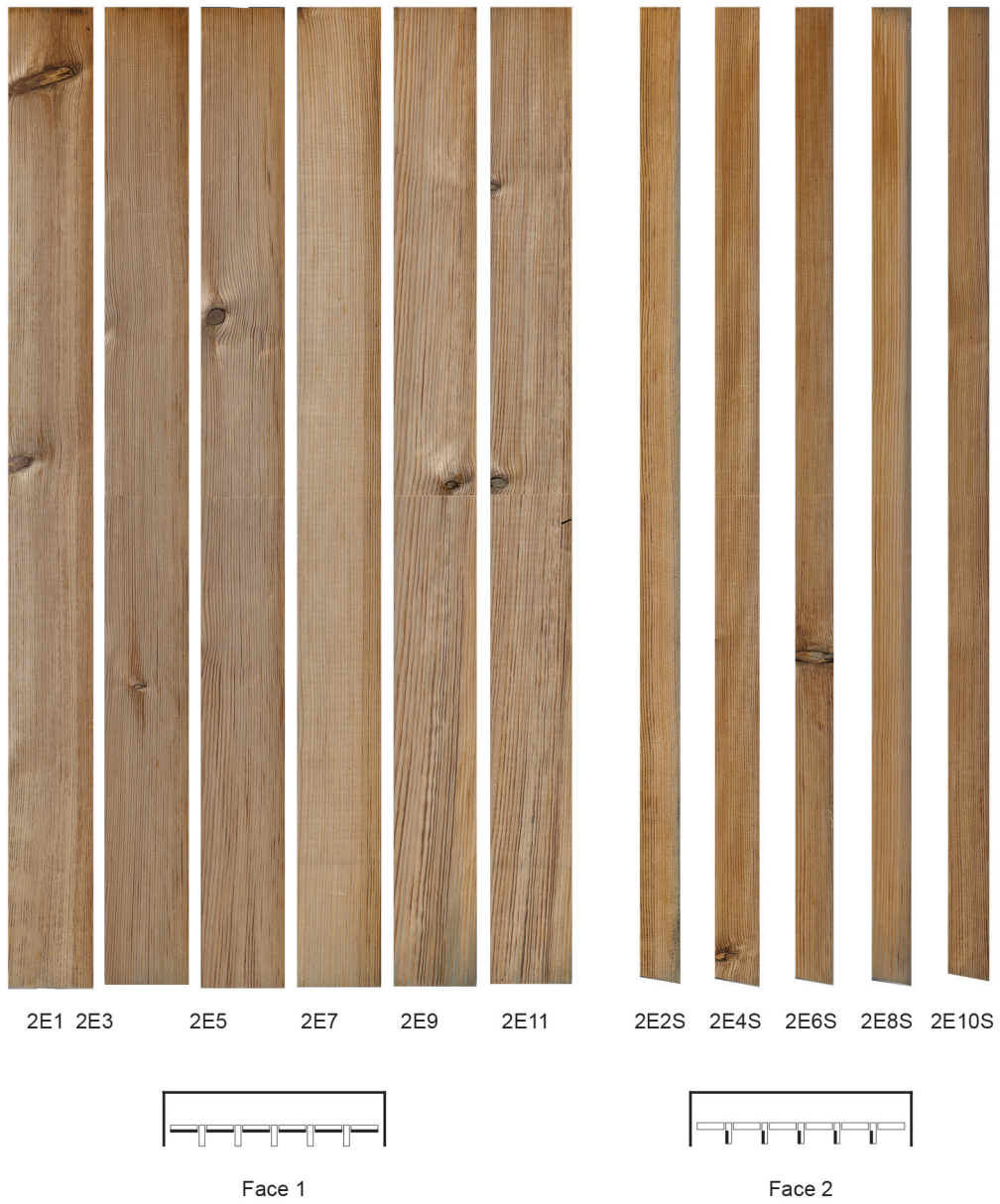

Figure 4.19 Sample 2E. Color development after 20 months of exposure to weather at the Voll research fields in Trondheim, Norway. From left to right face 1, 2, 3 and 4.



2E2 2E4 2E6 2E8 2E10



2E2N 2E4N 2E6N 2E8N 2E10N



Face 3

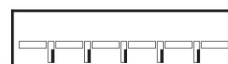

Face 4

Color of the newly planed wood surface



4.5 Cladding 3

Fig. 4.20 shows an overview of the color development of the four samples of Cladding 3 displayed in groups of the individual surfaces and as pattern repeat. For details of the color development please refer to Figs. 4.24–4.27. Figs. 4.21, 4.22 and 4.23 show the weather map modeling for Cladding 3.

4.5.1 Weathering color pattern

Cladding 3 shares geometrical features with Cladding 2 except that Cladding 3 was designed with protruding vertical boards that were twice the depth of those of Cladding 2. Comparing the surfaces of Cladding 3, Fig. 4.20 with corresponding surfaces of Cladding 2, Fig. 4.12 shows that the color development of Cladding 3 follows the same pattern as that of Cladding 2.

4.5.2 Analysis of the color development

The most distinct differences appear in the rate of grey color development of 3S Faces 1 and 2 and 3W Faces 1, 2 and 4. The grey color nuance is lighter on these surfaces of Cladding 3 compared to corresponding surfaces of Cladding 2.

The directional and spherical weather maps for Cladding 3, Figs. 4.22 and 4.23 compared to corresponding maps for Cladding 2, Figs. 4.14 and 4.15 demonstrate how the angle openings towards weather for Faces 1, 2 and 4 narrows as the relief deepens. The angle openings towards weather for Face 3 of Claddings 3 and 2 are identical.

The amount of WDR, UV and sun hours are all lower for Face 1 of Cladding 3 than for the corresponding Face of Cladding 2 as modeled in the surface weather maps, Figs. 4.21 and 4.13. This is the result of the shade created by the extended length of the protruding vertical boards.

The surface weather maps for Faces 2 and 4 of Cladding 3, Fig. 4.21 compared to Faces 2 and 4 of Cladding 2, Fig. 4.13 show that the weather exposure of the outermost half of these surfaces is identical.

The surface weather maps modeled for the rear half Faces 2 and 4 of Cladding 3 show a gradual decrease in the amount of WDR, UV and sun hours. The surface weather maps for Face 3 of Claddings 3 and 2 are identical, since these surfaces have identical locations in the respective samples.

Face 3

Face 3 of Claddings 3 and 2 share the same weather exposure conditions, and weathered in a similar manner. Sapwood is present in Face 3 of Cladding 3 in Boards 3N2+3N4+3N10, 3S4+3S6+3S10, and 3E4+3E6+3E10. Face 3 of 3W was not scanned.

Faces 2 and 4

Faces 2 and 4 of Cladding 3, Fig. 4.20 compared to corresponding surfaces of Cladding 2, Fig. 4.12 show that the surfaces share the same weathering characteristics on the outermost halves. The outermost halves are exposed to identical weather

conditions since the geometry of these parts of the claddings is identical.

Faces 2 and 4 of 3N, Face 4 of 3S, Faces 2 and 4 of 3E are predominantly brown on the foremost half and the color nuances continue towards the rear of these surfaces.

Sapwood is present in the outermost areas of Faces 2 and 4 where they adjoin Face 3 on boards 3N2E+3N10E, 3N2W+3N10W, 3S4W+3S6W+3S8W+3S10W, 3W2N+3W4N+3W6N+3W8N+3W10N+ 3W2S+3W4S+3W6S+3W8S+3W10S, 3E4S+3E6S+3E8S+3E10S, 3E4N+3E6N+3E8N, and 3E10N.

The dark grey color streaks on 3N2E+3N10E, and 3N4W+3N10W originate from cracks in the upper end grain area of these boards. It is likely that water originating from the plywood roof is the cause of elevated levels of moisture content that facilitated the growth of surface fungi locally. The cracks may have developed due to exposure to water or they may have been present from the beginning of the experiment. In either case the cracks collected and directed water onto the surfaces, resulting in dark grey streaks that are visually pronounced on the brown color background of these surfaces.

Face 2 of 3S and Faces 2 and 4 of 3W have developed a gradual transition from grey on the outermost part to a brown color towards the rear. This feature in the color development of the deeper relief cladding type corresponds to the information in the surface weather maps, Fig. 4.21. The maps show that the amount of WDR exposure decreases towards the rear. Lower amounts of WDR on the rear half can explain the decrease in the rate of the surface fungal growth, resulting in a brown color.

Face 1

Face 1 of Cladding 3, Fig. 4.20 compared to Face 1 of Cladding 2, Fig. 4.12 shows the same tendencies in color development, except that Face 1 of Cladding 3 developed grey at a slower rate than corresponding faces of Cladding 2.

Sapwood seems to be present on the right hand side edges of Face 1 of Cladding 3 as was the case for Face 1 of Cladding 2. The sapwood is particularly visible on right hand side of 3S and 3W as darker grey color compared to the neighboring heartwood tissue.

The surface weather maps suggest that exposure to WDR, UV and sun hours is lower for Face 1 of Cladding 3 than for corresponding surfaces of Cladding 2. This decrease in weather exposure on Face 1 is caused by the extended length of the protruding elements that decrease the angle opening towards weather. The slower rate of grey color development of Face 1 of Cladding 3 can be explained by the narrowing of the angle opening that reduced WDR access to Face 1.

4.5.3 Edge effects

Extractive deposits and dark grey color are visible on the uppermost areas of 3N Faces 1, 2 and 4 which is an indication of exposure to water. Since these areas should have been protected from direct exposure to water, it is likely that water exposure originated from the roof of the plywood frame.

Brown color and extractives are visible on the uppermost areas of 3S, 3W and 3E Faces 1, 2 and 4. These deviations have their origins in the shade created by the plywood roof, as discussed in the analysis of Cladding 2.

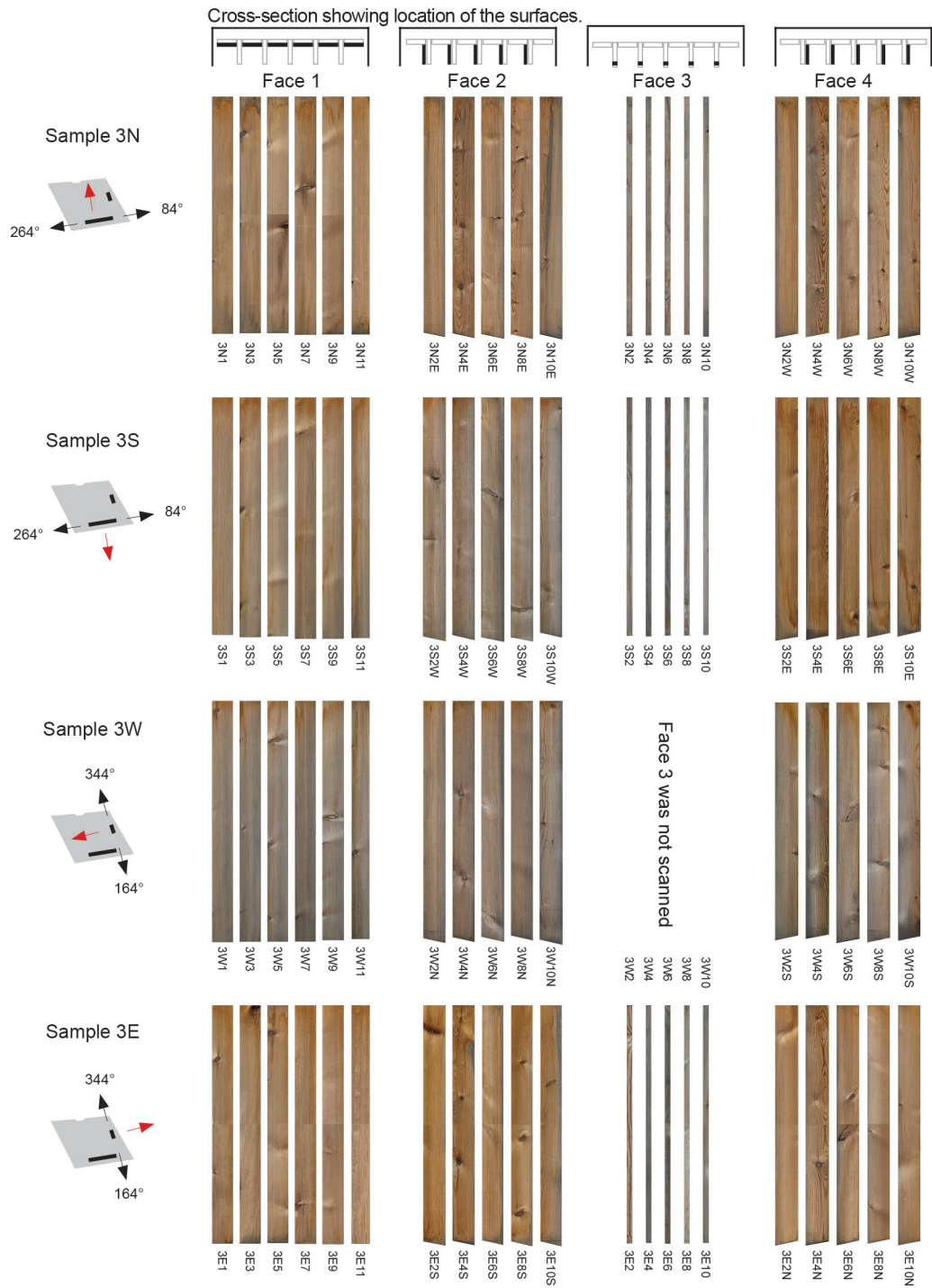

Figure 4.20 Cladding 3. Weathering colors of the four samples after 20 months of exposure to weather at the Voll research fields in Trondheim. The surfaces are displayed in groups of the individual surfaces and as pattern repeat.

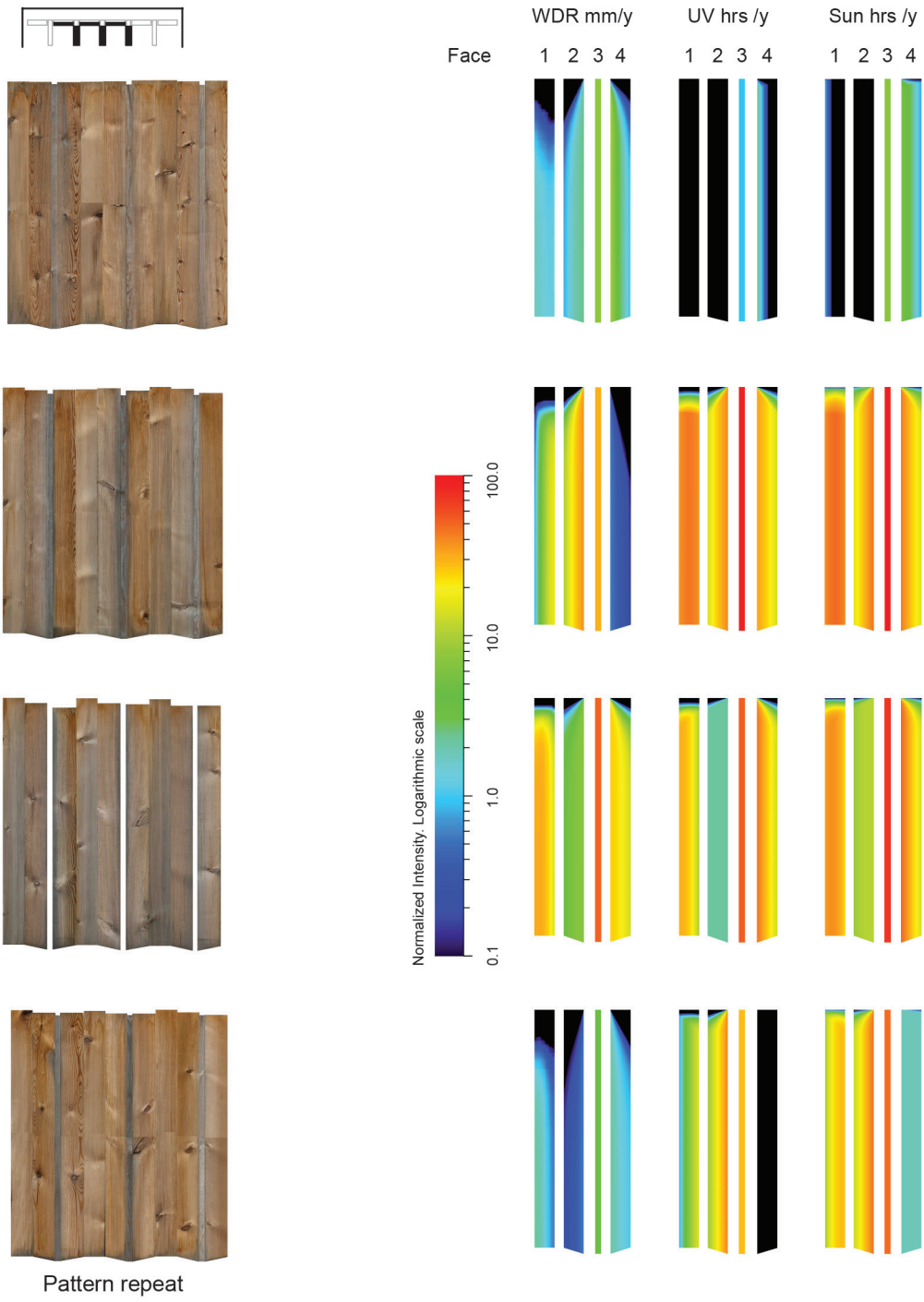

Figure 4.21 Cladding 3. Surface Weather Maps.

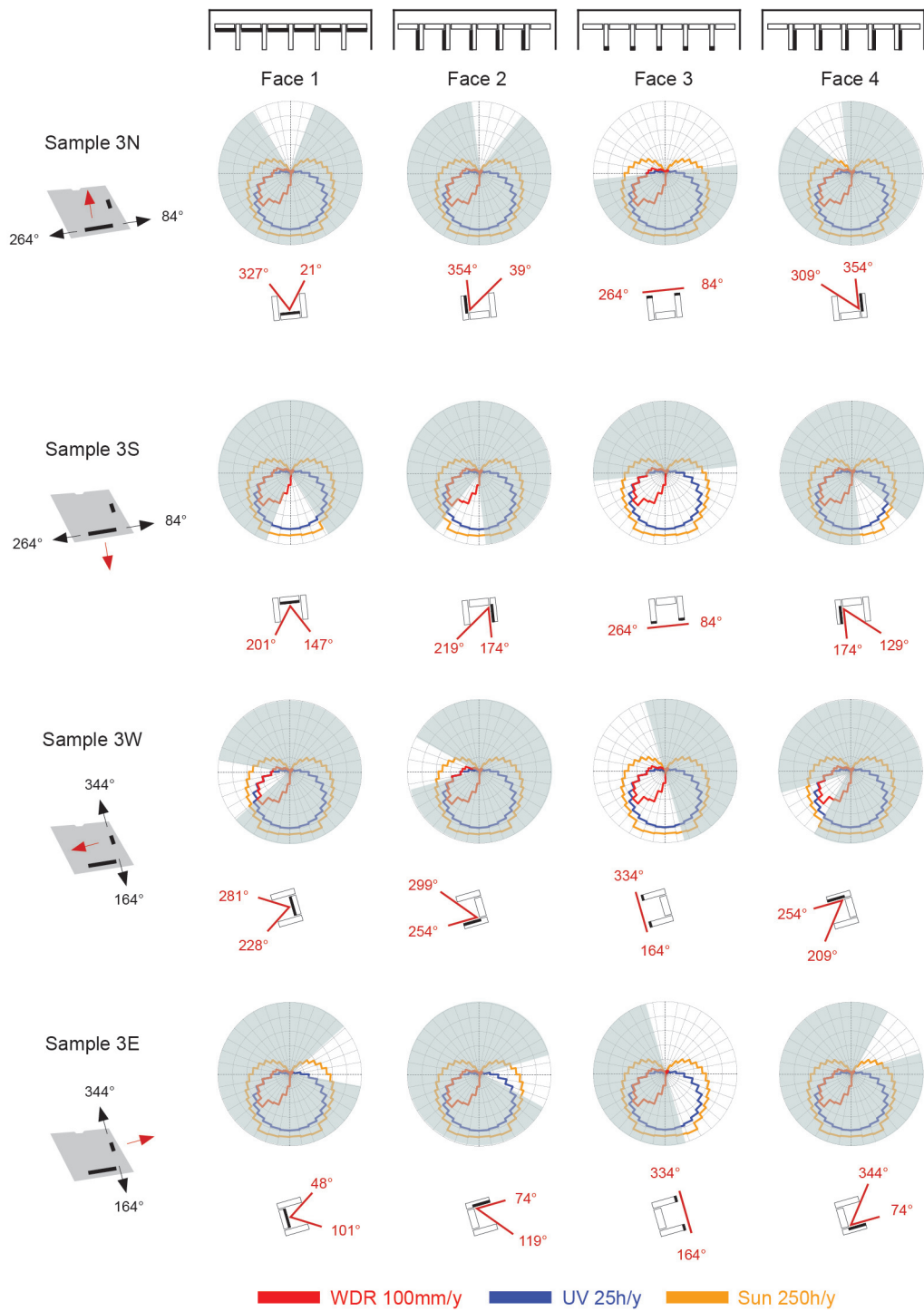

Figure 4.22 Cladding 3. Directional weather maps for the individual surfaces of cladding 3. The white areas indicate sectors corresponding to the angle openings of the surfaces.

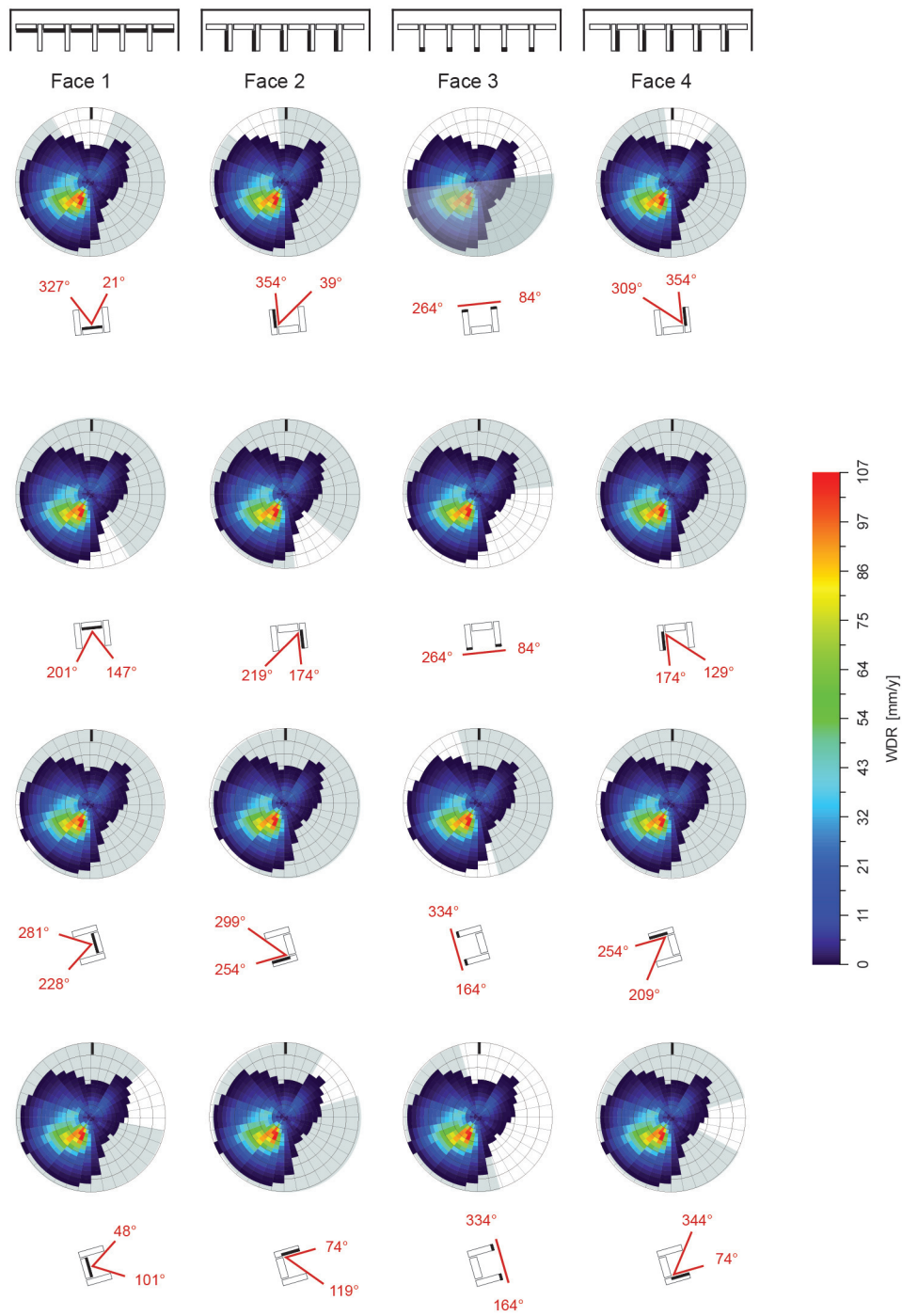

Figure 4.23 Cladding 3. Spherical weather maps for the individual surfaces of cladding 3. The white areas indicate sectors corresponding to the angle openings of the surfaces.

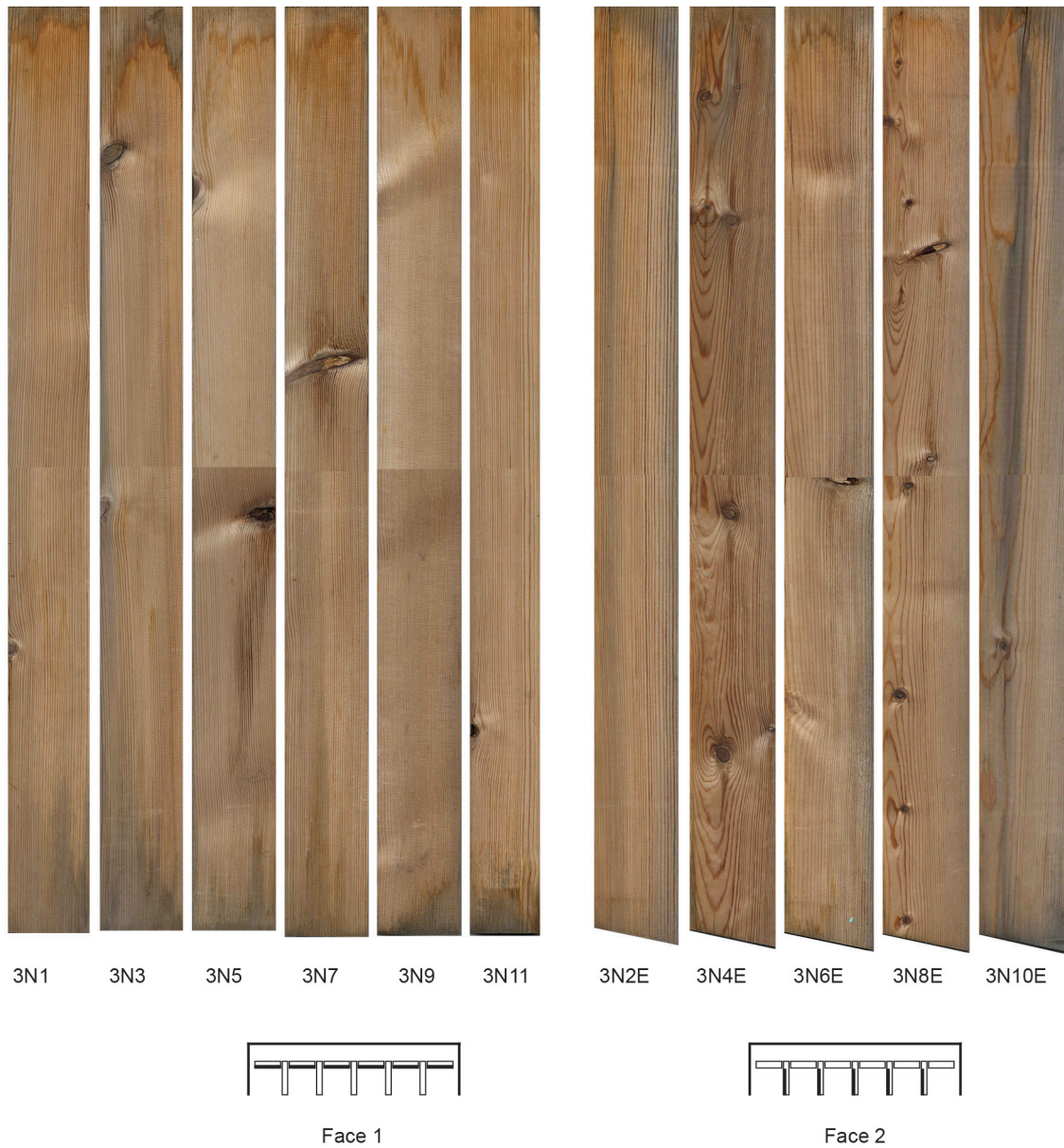

Figure 4.24 Sample 3N. Color development after 20 months of exposure to weather at the Voll research fields in Trondheim, Norway.



3N2 3N4 3N6 3N8 3N10



3N2W 3N4W 3N6W 3N8W 3N10W

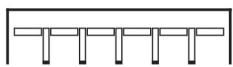

Face 3



Face 4

Color of the newly planed wood surface



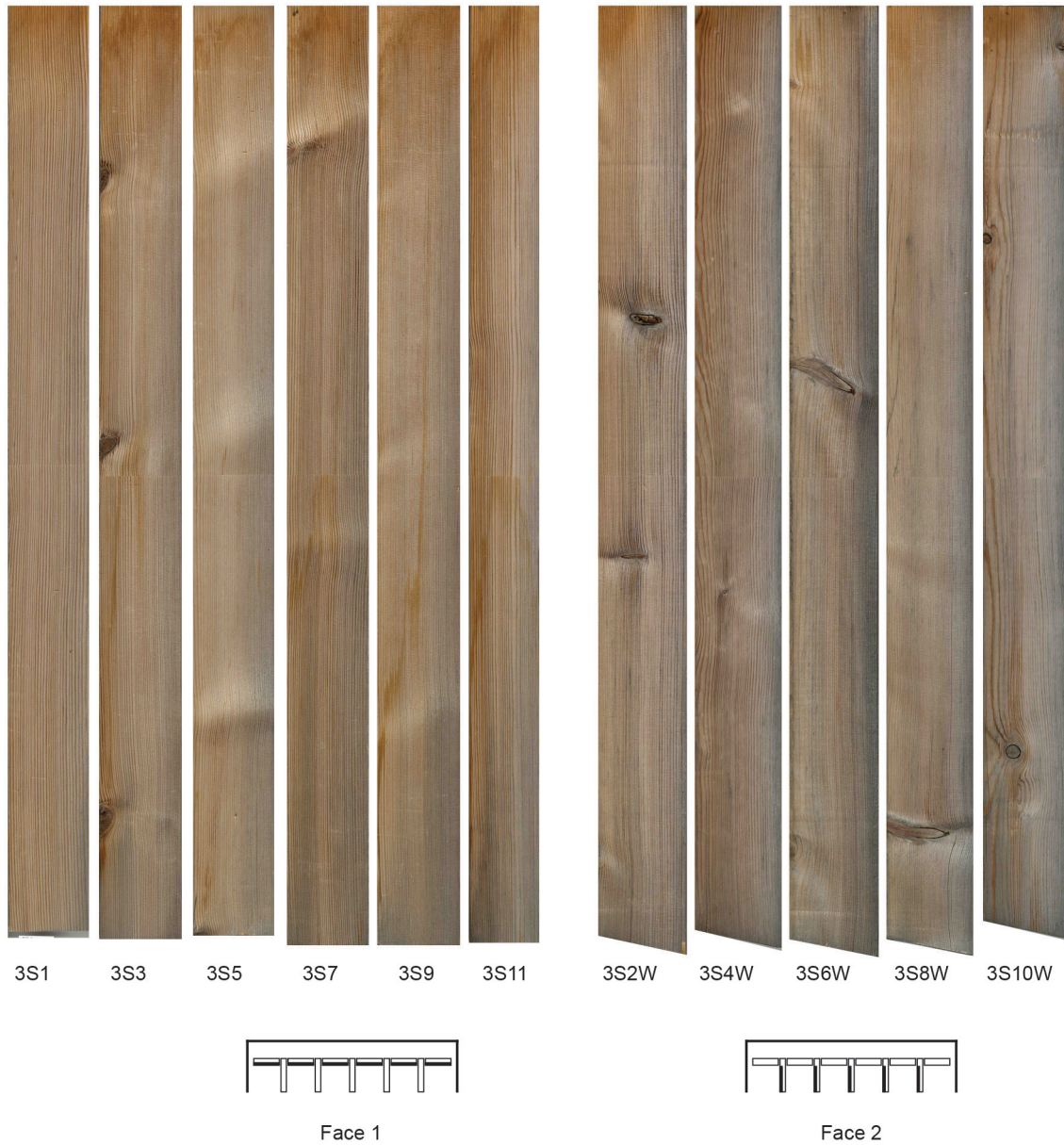

Figure 4.25 Sample 3S. Color development after 20 months of exposure to weather at the Voll research fields in Trondheim, Norway.



3S2 3S4 3S6 3S8 3S10



3S2E 3S4E 3S6E 3S8E 3S10E

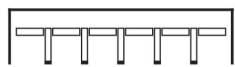

Face 3



Face 4

Color of the newly planed wood surface





Figure 4.26 Sample 3W. Color development after 20 months of exposure to weather at the Voll research fields in Trondheim, Norway.

Face 3 not scanned.
3W face 3 resemble 2W face 3.



3W2 3W4 3W6 3W8 3W10

3W2S 3W4S 3W6S 3W8S 3W10S

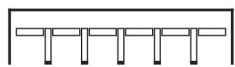

Face 3

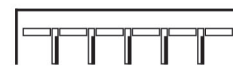

Face 4

Color of the newly planed wood surface



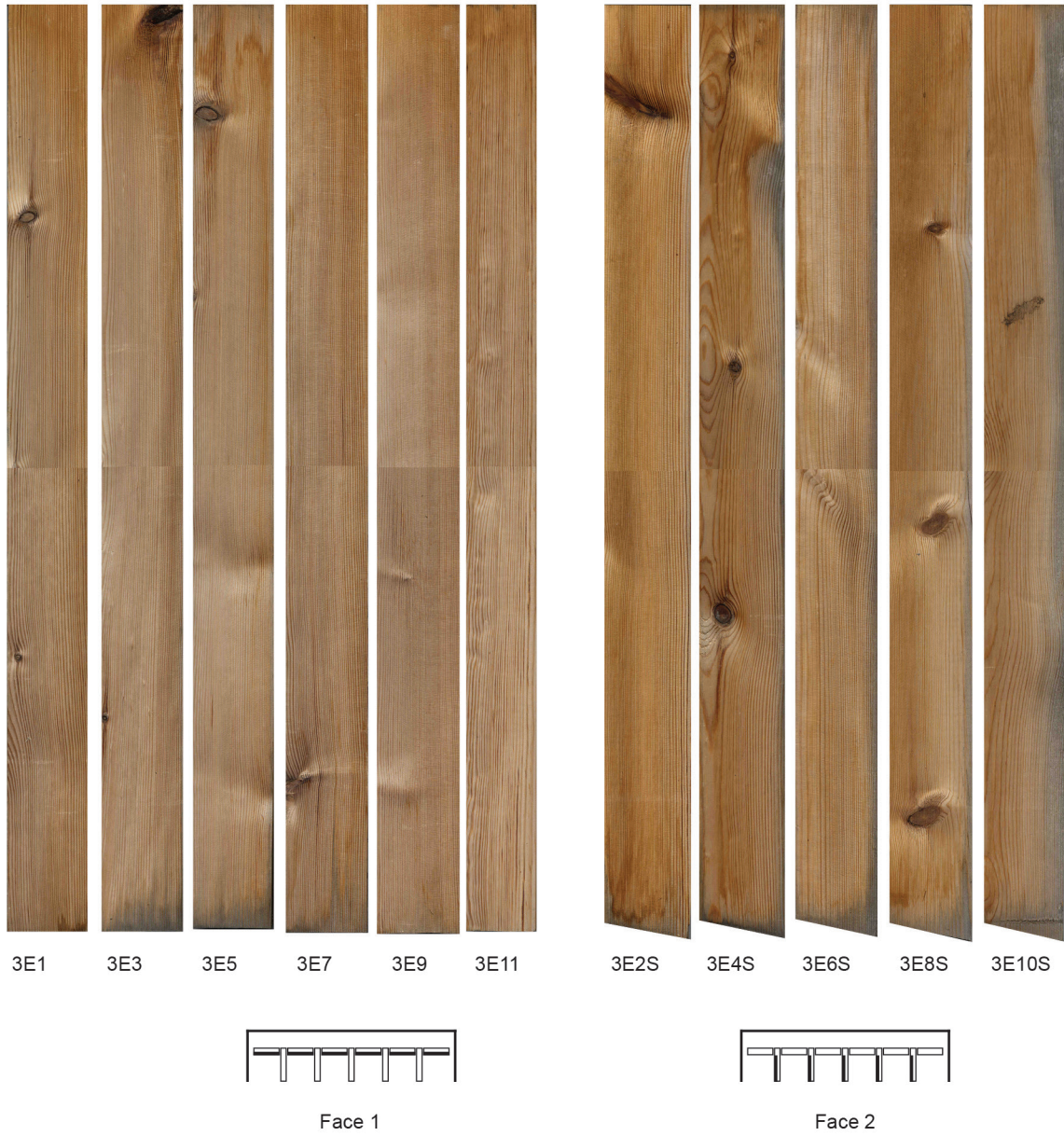

Figure 4.27 Sample 3E. Color development after 20 months of exposure to weather at the Voll research fields in Trondheim, Norway.



3E2

3E4

3E6

3E8

3E10

3E2N

3E4N

3E6N

3E8N

3E10N

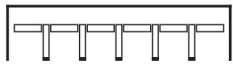

Face 3



Face 4

Color of the newly planed wood surface



4.6 Cladding 4

Fig. 4.28 shows an overview of the color development of the four samples of Cladding 4. For details in the color development please refer to Figs. 4.32–4.35. Figs. 4.29–4.31 show the weather maps modeled for Cladding 4.

The geometry of Cladding 4 is similar to that of Cladding 1 except for the direction of the boards that are mounted horizontally in cladding 4. The directional, spherical and surface weather maps modeled for Cladding 4 are identical to the maps modeled for Cladding 1.

4.6.1 Weathering color pattern

The heartwood parts of Sample 4W appear to be slightly darker grey than those of 4S followed by 4N and 4E. These samples also contain sapwood which makes the weathering pattern appear two-toned.

Sapwood is clearly visible in boards 4N5+4N7+4N15+4N17+4N19, 4S5+4S7+4S15+4S17+4S19, 4W1+4W5+4W15+4W17+4W19, and 4E17+4E19.

4.6.2 Analysis of the color development

Comparing the overview of the color development for Cladding, 4 Fig. 28 to that of Cladding 1, Fig. 4.4 shows that 4W appears lighter grey than 1W, and 4E appears to be darker brown than 1E. Comparing 4S to 1S and 4N to 1N show that the heartwood color nuance of these samples appear to be of similar grey color tone.

Logically, all samples of Cladding 4 should have developed color similar to corresponding samples of Cladding 1. The differences between 4W+4E and 1W+1E can be explained by the tilted east-west facing frame as discussed in Section 4.1.3. It is likely that the weathering color of 4W and 4E represent the weather exposure of vertically standing claddings whereas 1W and 1E represent the weathering under the tilted conditions.

The lowermost boards of Cladding 4, Boards 21, were unplanned. In all four samples, Boards 21 appear darker and more homogeneous compared to the other planed surfaces in the respective samples. The darker and more homogeneous appearance can be explained by the roughness of the unplanned surface, which blurs the color differences between early and late wood. These differences are more distinctive on the planed surfaces. The darker appearance can also be explained by capillary suction in the numerous strands of end grain in the surfaces created during machining of the wet logs.

4.6.3 Edge effects

Sample 4E was possibly affected by edge effect from the plywood protective frame. There appears to be a darker grey color on the right hand side of the cladding which could have originated from water dripping off the plywood roof.

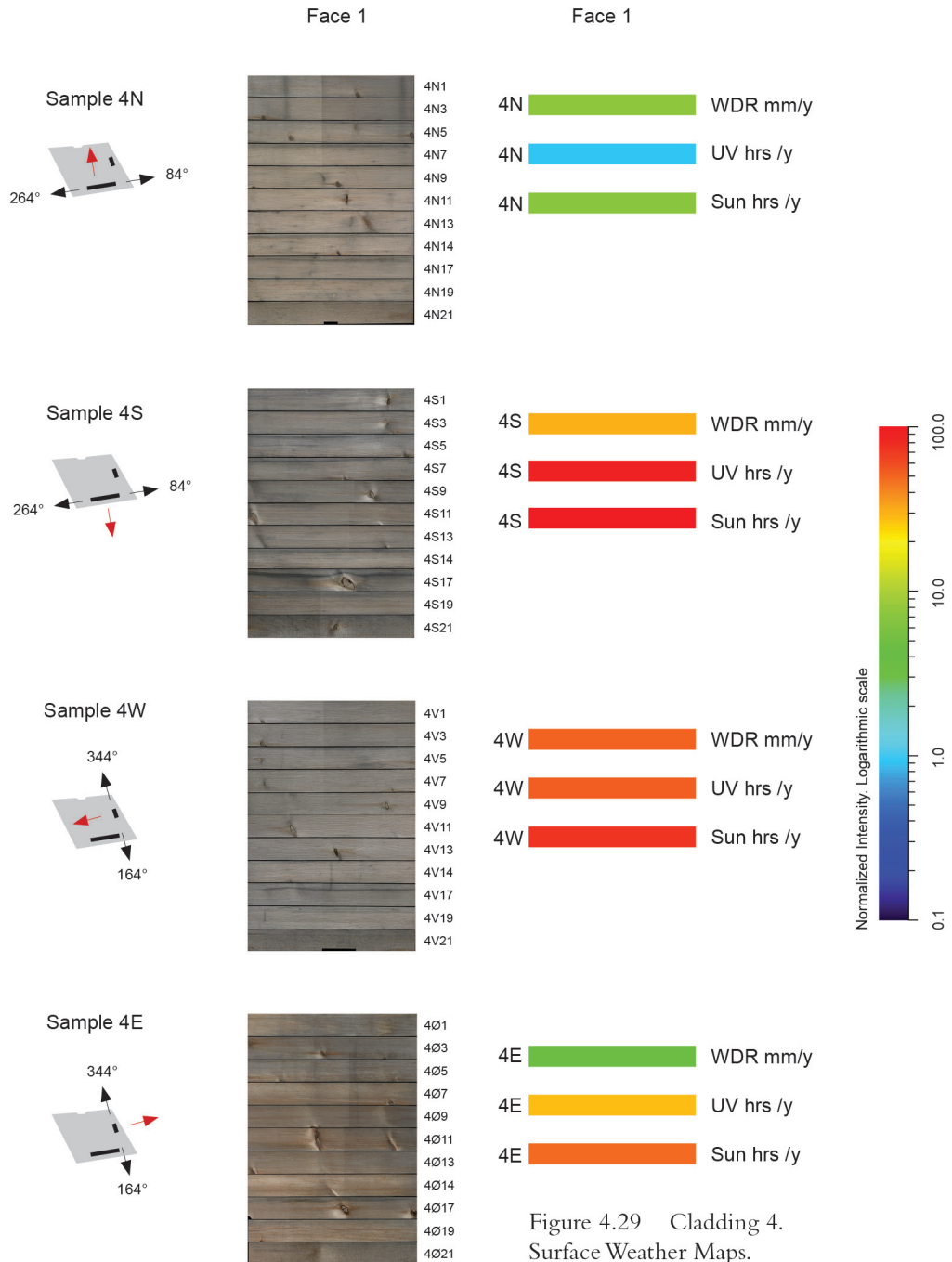

Figure 4.28 Cladding 4. Weathering colors of the four samples after 20 months of exposure to weather at the Voll research fields in Trondheim.

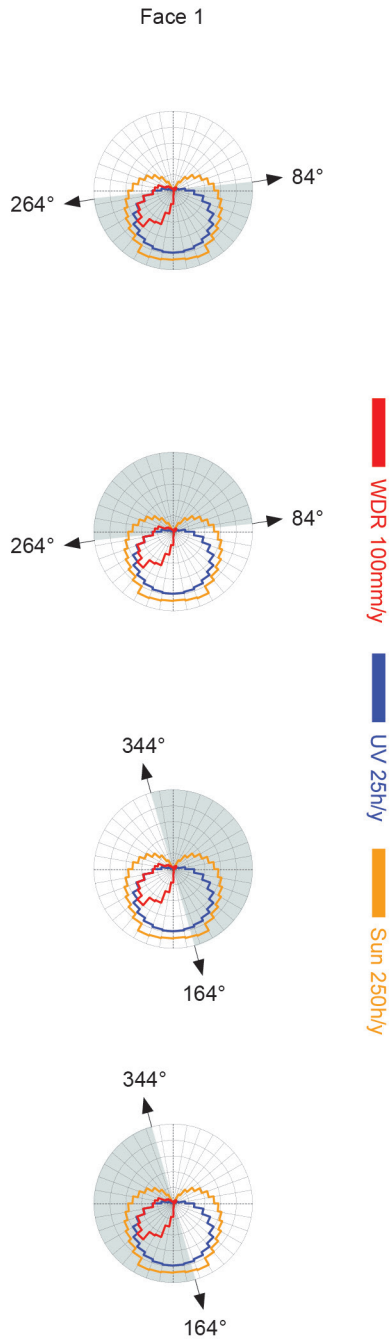

Figure 4.30 Cladding 4.
Directional Weather Maps.

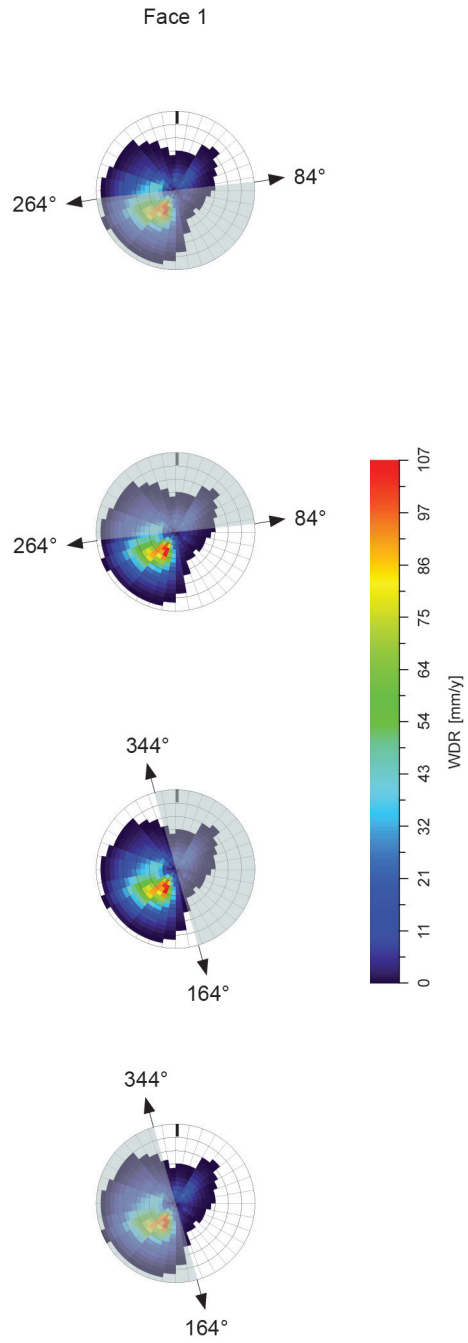
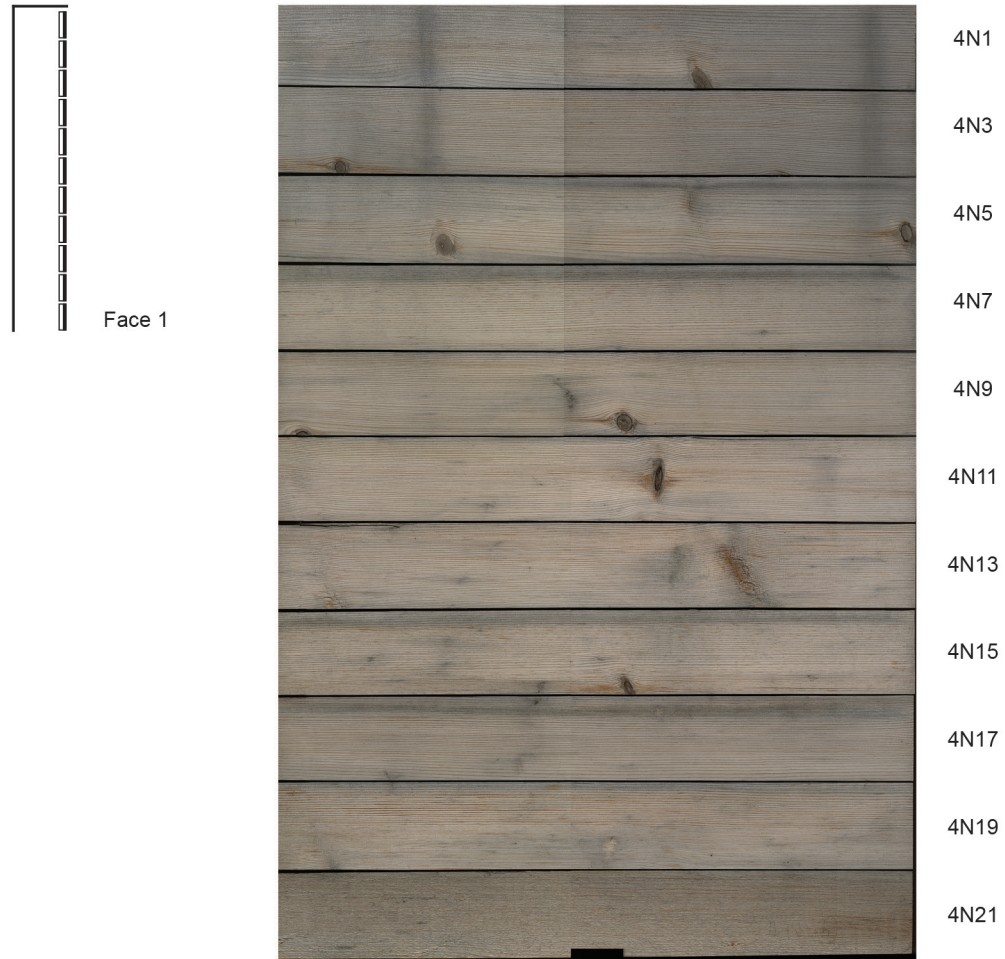

Figure 4.31 Cladding 4.
Spherical Weather Maps.



Color of the newly planed wood surface.

Figure 4.32 Sample 4N. Color development after 20 months of exposure to weather at Voll research fields in Trondheim, Norway.

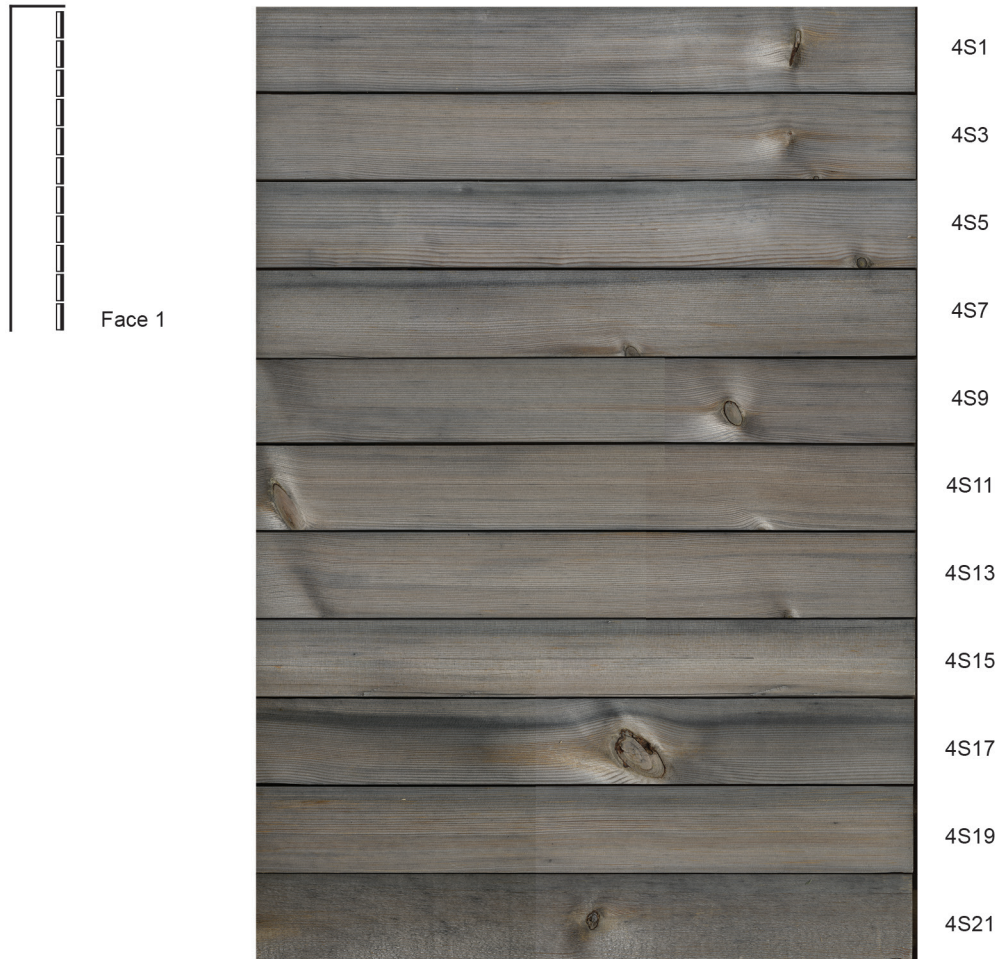
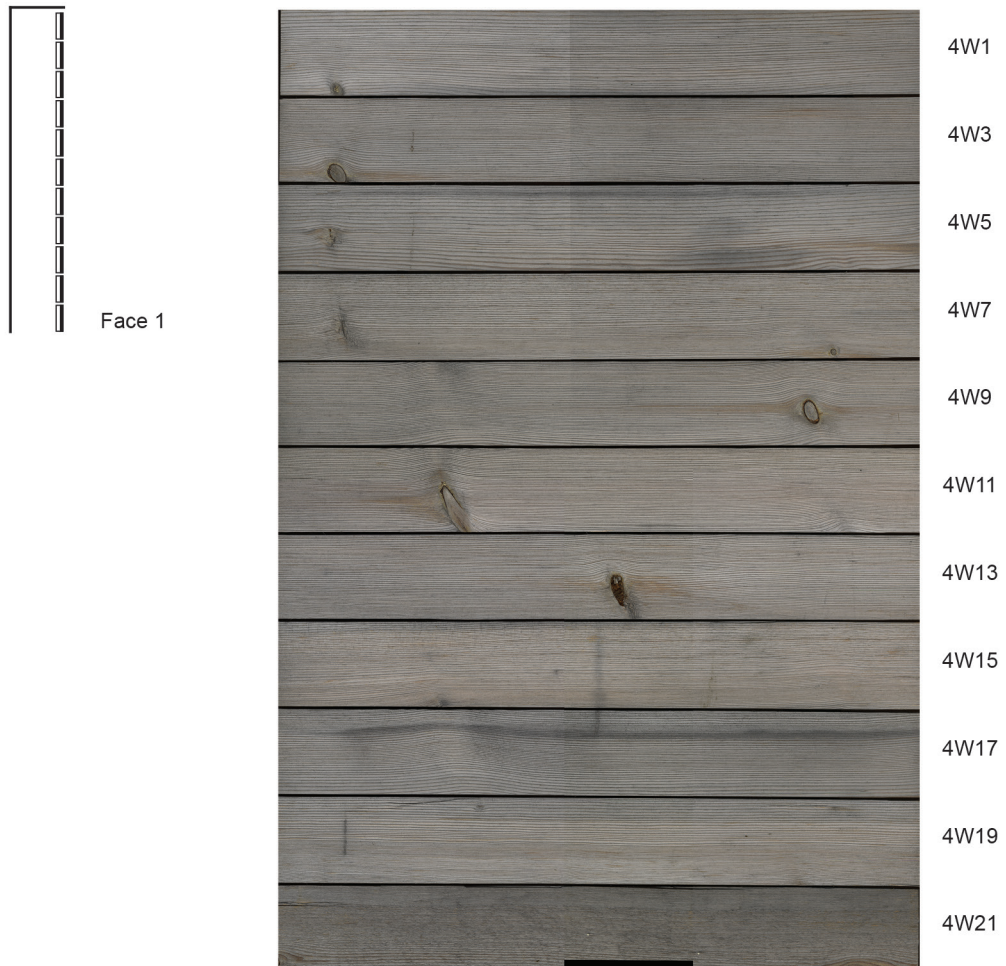

Figure 4.33 Sample 4S. Color development after 20 months of exposure to weather at the Voll research fields in Trondheim, Norway.



Color of the newly planed wood surface.

Figure 4.34 Sample 4W. Color development after 20 months of exposure to weather at the Voll research fields in Trondheim, Norway.

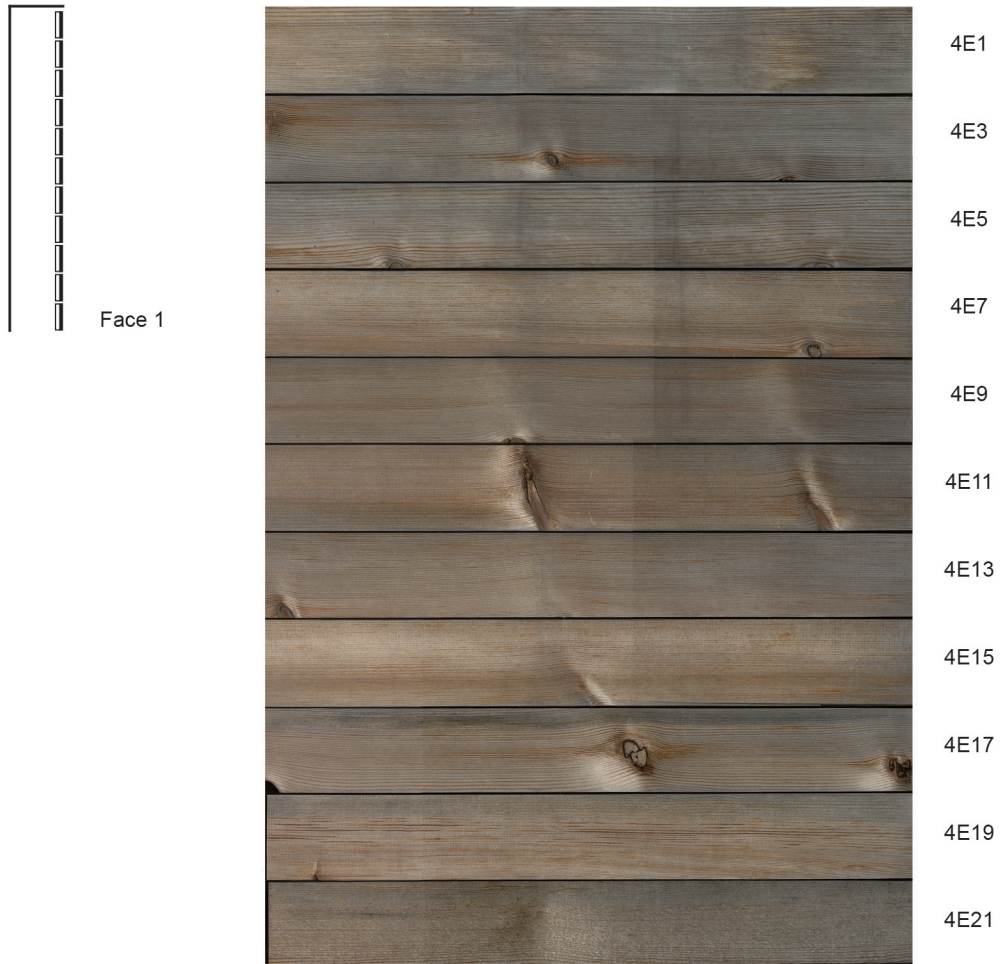

Figure 4.35 Sample 4E. Color development after 20 months of exposure to weather at the Voll research fields in Trondheim, Norway.

4.7 Cladding 5

Fig. 4.36 shows an overview of the color development of the four samples of Cladding 5 displayed in groups of the individual surfaces and as the pattern repeat. For details in the color development please refer to Figs. 4.40-4.43. Figs. 4.37, 4.38 and 4.39 show the weather maps modeled for Cladding 5.

4.7.1 Weathering color pattern

5N has developed a pattern of two-colored Face 1, characterized by a grey colored streak on the lowermost part of the boards and brown with extractives on the upper area. Face 2 is dark grey with a light covering of bird droppings. Face 3 is dark grey. Face 4 is brown and grey with extractives, and a grey edge on the foremost part adjoining Face 3.

5S has developed a pattern of two-colored Face 1, characterized by dark grey coloring of the lower half of the boards, and brown with extractives on the upper part. Faces 2 and 3 are dark grey. Face 4 is grey-brown with extractives and a grey edge on the foremost part adjoining Face 3.

5W has developed a pattern of two-colored Face 1, characterized by dark grey color on the larger part of the surface area, and a streak of brown with extractives on the uppermost part. Faces 2 and 3 are dark grey. Face 4 has a pattern of grey-brown with extractives and a grey edge on the foremost part adjoining Face 3.

5E has developed a pattern of two-colored Face 1, characterized by light grey to brown color on the lowermost half and brown color with some extractives on the uppermost part. Face 2 is light grey with substantial coverage of bird droppings. Face 3 is grey on the early wood and brown on the latewood tissue. Face 4 is brown with extractives and a grey edge on the foremost part adjoining Face 3.

4.7.2 Analysis of the color development

The directional and spherical weather maps for Faces 1 and 2, Figs. 4.38 and 4.39 are shown as identical maps. For both faces, the angle opening towards weather is illustrated as a 165° opening calculated from the center of the place where Faces 1 and 2 adjoin. The horizontal angle opening of Face 1 can change a maximum of 15° in the sideways horizontal plane, but does not change when changing the point of calculation in a vertical plane. The horizontal angle opening of Face 2 can change a maximum of 15° in the horizontal plane from its minimum angle opening of 165° at the rear, to a maximum opening of 180° where face 2 adjoins Face 3. No better solution was found than illustrating the horizontal angle openings towards weather in a similar manner for Faces 1 and 2. Face 3 is illustrated with a 180° angle opening, similar to Face 3 of Claddings 2 and 3. Face 4 is fully shaded, which is illustrated as a complete masking of the sector.

The directional and spherical weather maps, Figs. 4.38 and 4.39 demonstrate that the four surfaces in this cladding type face the same 180° sector, as opposed to the surfaces of Claddings 2 and 3 that face different parts of the horizon. Cladding 5 has large angle openings towards the horizon, whereas Claddings 2 and 3 have narrower angle openings.

The vertical sides of the plywood frame narrow the weather access of Faces 1 and 2. Without the plywood frame, the angle opening towards the horizon would be a 180° sector identical to that of Face 3.

The horizontally protruding boards of this cladding type create gradual shade on Faces 1 and 2. Face 3 is non-shaded and Face 4 is fully shaded. The significant differences in the surface shade conditions create differences in weather accessibility to the surfaces, resulting in significant color variations of the surfaces of the cladding type. Most pronounced is the color contrast between the upward facing Face 2, and downward facing Face 4, that developed grey and brown color respectively. The four samples of Cladding 5 developed similar characteristic color patterns towards the four directions at Voll, however distinct differences in the proportion of grey and brown color developed on Face 1.

Face 1

Face 1 of all samples of Cladding 5 developed a two-colored surface characterized by grey on the lower, and brown with extractives on the upper parts of the surfaces. 5W developed the darkest and most grey coverage, followed by 5S, 5N and 5E.

Sapwood seems to be present on the lowermost part of Face 1 of all samples. On 5E sapwood is only clearly recognizable on 5E1, 5E5 and 5E7.

The directional weather map, Fig. 4.38 shows that 5W and 5S were facing the main WDR direction at Voll and 5N and 5E were turned away from the main WDR direction. The spherical WDR weather maps, Fig. 4.39 suggests that WDR falls in high amounts at low angles directly towards 5W and 5S, whereas low amounts of WDR fall at high angles towards 5N and 5E.

The surface weather maps, Fig. 4.37 suggest that the WDR exposure pattern for Face 1 is characterized by the highest exposure towards the lower parts of 5W, followed by 5S, 5N and 5E. This WDR exposure pattern agrees well with the color development of Face 1 of the four samples. Exposure to high amounts of WDR on a large part of the lower surface area facilitated the fast growth of dark walled fungi on 5W. Exposure to lower amounts of WDR over a smaller area can explain why 5S Face 1 developed a smaller area of grey compared to 5W Face 1. In addition, 5S Face 1 was exposed to high amounts of UV and sun hours which may have shortened the TOW resulting in shorter periods of favorable moisture conditions for surface fungal growth. Exposure to low amounts of WDR falling at high angles can explain why 5N Face 1 developed a small streak of grey on the lowermost edge. Note that sapwood is present in the lowermost part of Face 1, which could be the cause of the grey streaks particularly visible on 5N. Exposure to a combination of very low amounts of WDR, in combination with high amounts of UV and sun hours, kept 5E Face 1 very dry, which retarded the growth of surface fungi significantly compared to 5W, 5S and 5N.

Extractives developed at the upper border of the grey color of Face 1. The emergence of extractives can be explained by migration of water containing soluble extractives from the lower WDR-exposed areas to the upper drier areas of the surfaces where they deposit.

Face 2

Face 2 of 5W developed uniform dark grey color whereas Face 2 of 5S, 5N and 5E developed dark grey on the foremost half, and dark brown on the rear part of the surfaces. In addition, bird droppings cover a substantial part of 5E, and to a lesser degree Face 2 of 5N. The surface weather maps, Fig. 4.37 suggest that Face 2 of 5W was exposed to high amounts of WDR covering the total surface area, which can explain the dark and uniform grey color development of 5W. The surface weather maps suggest that Face 2 of 5S was exposed to high amounts of WDR on its foremost part gradually decreasing to the rear part of the surface. This can explain the brown color to the rear of Face 2 of 5S. The surface weather maps suggest a similar WDR exposure pattern of Face 2 of 5N and 5E, with significantly lower amounts of WDR to the front of the surfaces and a decrease towards the rear. This can explain the grey color in the front and brown color towards the rear of these surfaces.

Birds seem to have likes using the horizontally protruding boards of Cladding 5 as a resting place. 5E was heavily covered with bird droppings. There was significantly less on 5N, and practically none on 5W and 5S. Exposure of 5W and 5S to regular showers probably washed the droppings off these surfaces, whereas dirt remains on 5E, due to the low amounts of WDR directed towards these surfaces. Whether dirt was washed away from 5N by rain, or if the shady, north-facing location is just a less attractive resting place for birds remains an open question.

Face 3

Face 3 of the four samples of Cladding 5 share the same exposure conditions as Face 3 of Claddings 2 and 3. It appears that these foremost, non-shaded surfaces of Cladding 5 are somewhat darker grey than corresponding surfaces of Claddings 2 and 3. This can be explained by water running off the slightly downward inclined Face 2, resulting in elevated amounts of water on Face 3. This favors fast growth of dark walled fungi.

Face 4

Face 4 of 5W and 5S has developed a grey-brown color, whereas 5N and 5E appear clearly more brown than grey. These surfaces are downward facing and unexposed to direct weather, yet have still developed weathering colors. The brown color clearly visible on Face 4 of all samples may have developed from exposure to daylight, heat and possibly also reflections from sun rays. The grey color particularly visible on 5W and 5S most likely stems from raindrops splashing from Faces 1 and 2, and being deflected onto Face 4. 5W and 5S were facing sectors with large amounts of WDR falling at low angles, as suggested by the spherical weather maps, Fig. 4.39. This can explain why Face 4 of these two samples developed a grey-brown color. 5N and 5E were facing sectors with significantly lower amounts of WDR falling at high angles, likely resulting in less wetting of Face 4 from deflected raindrop splash. The foremost edge that adjoins Face 3 has developed dark grey on all samples. This dark grey color streak most likely originates from the WDR-exposed Face 3 that adjoins Face 4. Wetting of this surface, and water running off Face 3, most likely adds moisture to the

adjoining area of Face 4. This results in favorable growth conditions for dark walled fungi.

Extractives also developed on these downward facing surfaces. Extractives may have developed as a result of migration and deposit caused by moisture from rain-drop splash. Extractives may also have developed as a result of extractive-containing water migrating from the WDR-exposed Face 2 to the drier opposite surfaces of Face 4. This extractive migration pattern was also suggested for Face 4 of 2S and 3S and Face 2 of 2E and 3E.

4.7.3 Edge effects

The color development of the lowermost boards of Face 1, (Boards 17) and Face 4 (Boards 16) is distinguished from that of the remaining surfaces of Faces 1 and 4. This is particularly visible on 5S and 5W. The geometry of these surfaces differs from the geometry of the remaining surfaces. These two boards finish the cladding and there are no horizontally protruding boards below to play a part in the color development of the above-located surfaces.

The grey color on the left and right sides of Face 1 of all samples covers a larger area than the central part of the surfaces. It is likely that this particular color development of Face 1 is an edge effect caused by the vertical sides of the plywood protective frame. In the event of WDR, raindrops also hit the plywood side surfaces from where splash may project onto the left and right sides of Face 1. Capillary action in the end grain areas of these surfaces also likely contribute to elevated amounts of moisture in the end grain regions, resulting in more favorable growth conditions for dark walled fungi compared to the central parts of these surfaces.

Left and right sides of Face 4 of all samples also have distinct color differences between the end grain regions and the central areas, however less pronounced than those of Face 1. This detail in the color development could likewise stem from a combination of edge effects from the vertical plywood sides and capillary actions in the end grain areas.

CHAPTER 4: RESULTS AND DISCUSSION

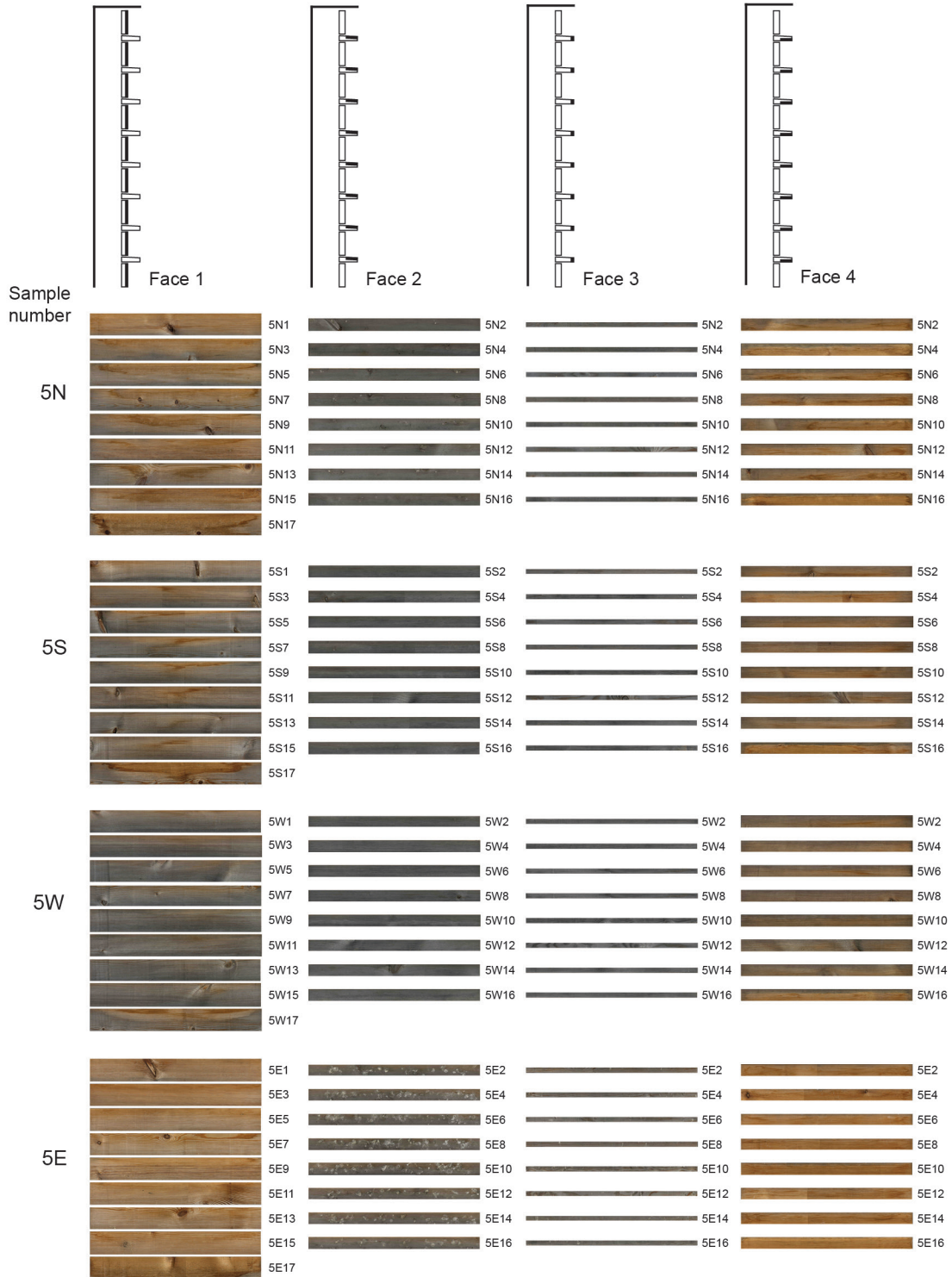
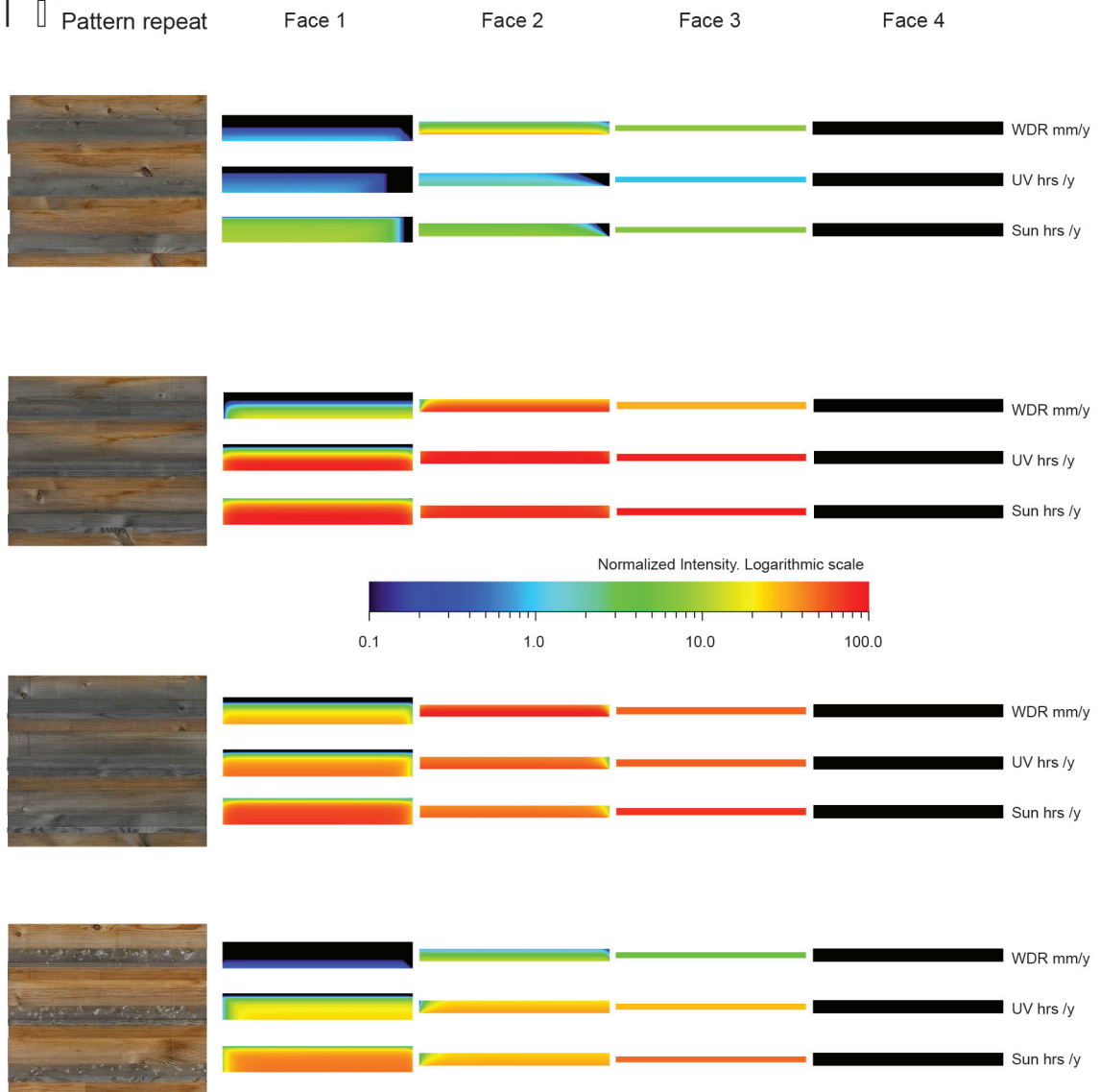



Figure 4.36 Left side. Cladding 5. Weathering colors of the four samples after 20 months of exposure to weather at the Voll research fields in Trondheim. Displayed in groups of the individual surfaces and as the pattern repeat.

Figure 4.37 Below. Cladding 5. Surface Weather Maps.



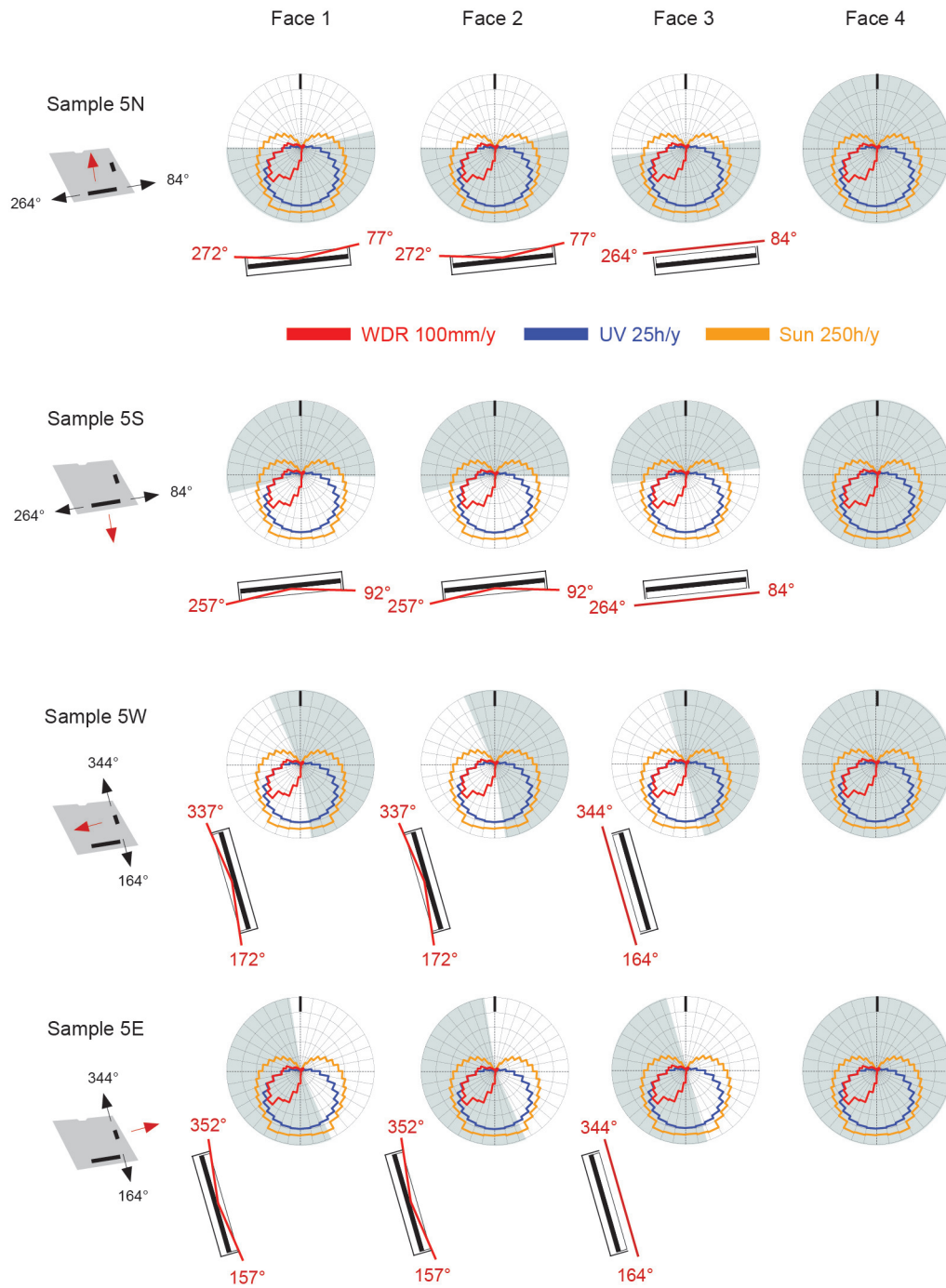

Figure 4.38 Cladding 5. Directional weather maps for the individual surfaces of Cladding 5. The white areas indicate sectors corresponding to the angle openings of the surfaces.

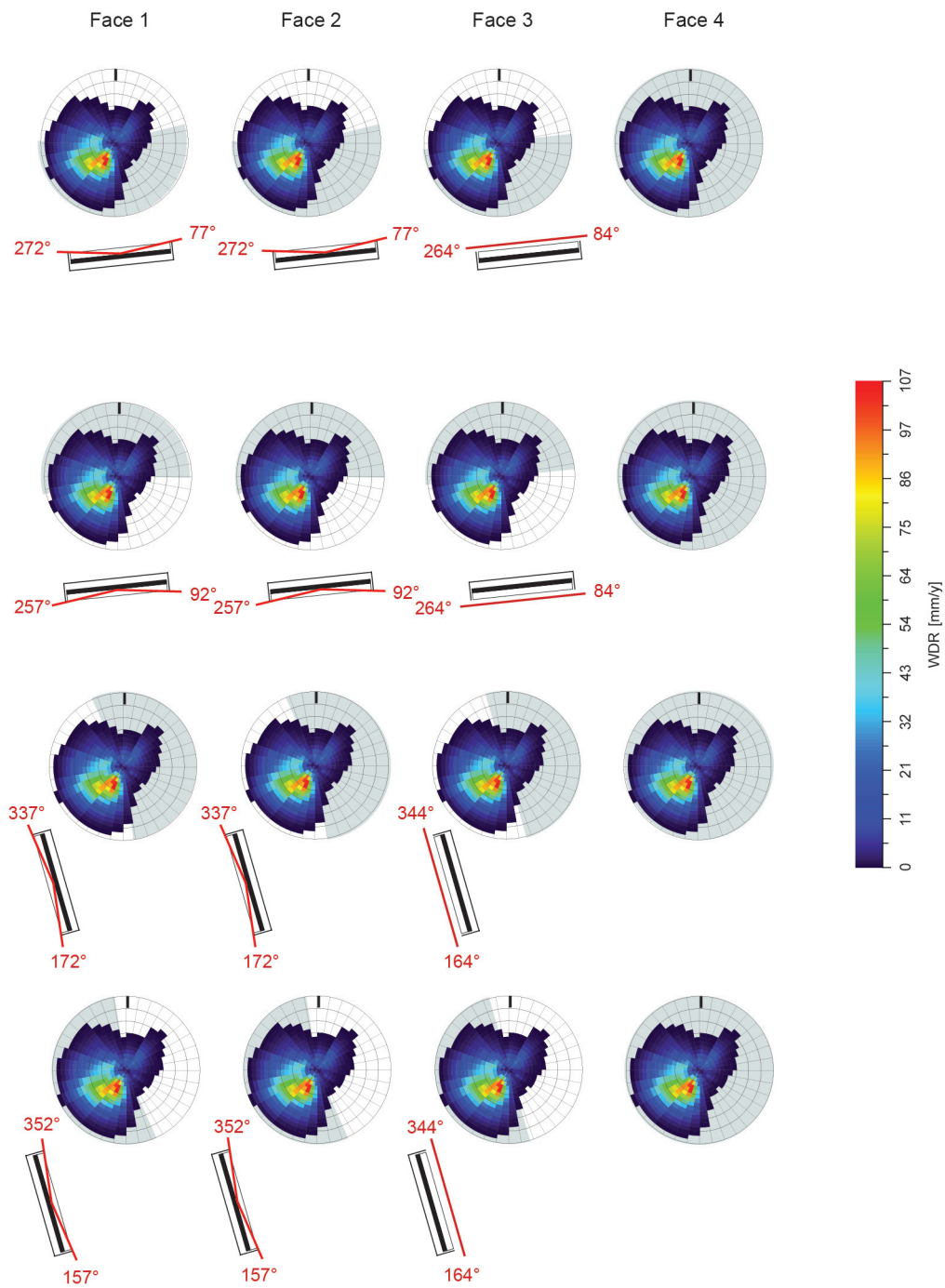

Figure 4.39 Cladding 5. Spherical weather maps for the individual surfaces of Cladding 5. The white areas indicate sectors corresponding to the angle openings of the surfaces.

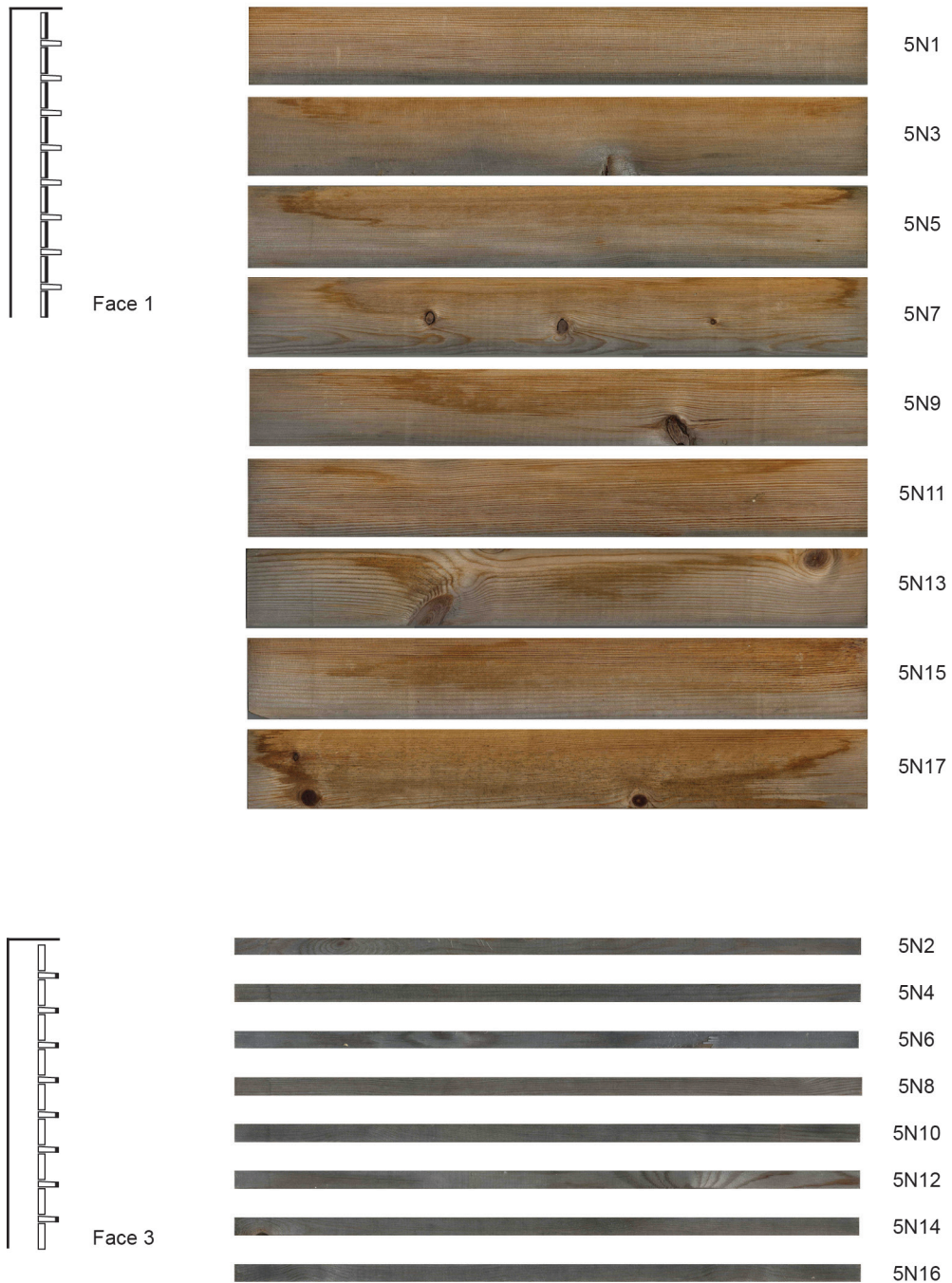

Figure 4.40 Cladding 5N. Color development after 20 months of exposure to weather at the Voll research fields in Trondheim, Norway.



Face 2



5N2

5N4

5N6

5N8

5N10

5N12

5N14

5N16



Color of the newly planed wood surface.

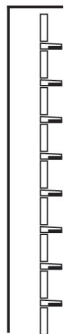

Face 4



5N2

5N4

5N6

5N8

5N10

5N12

5N14

5N16

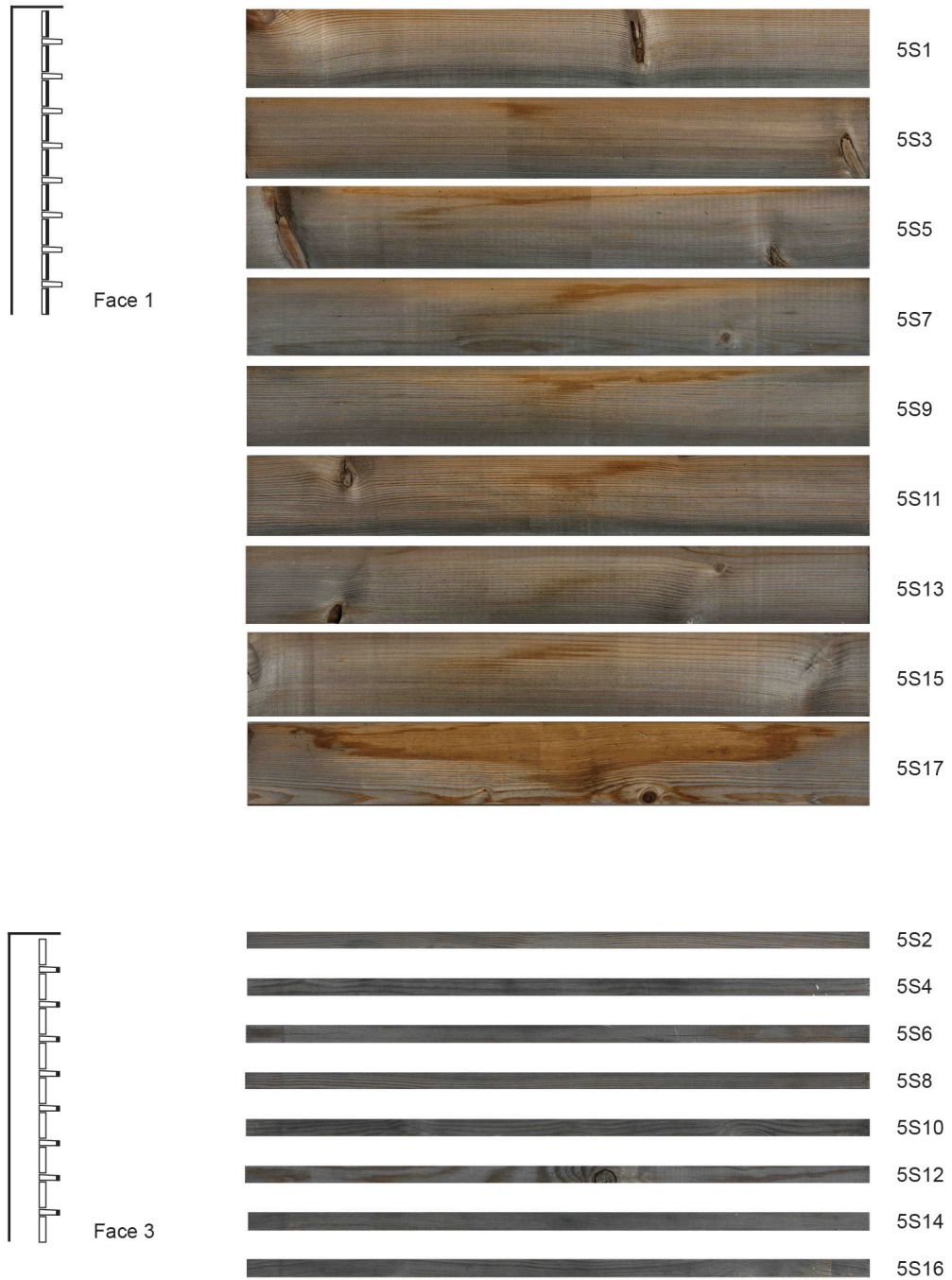
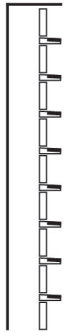
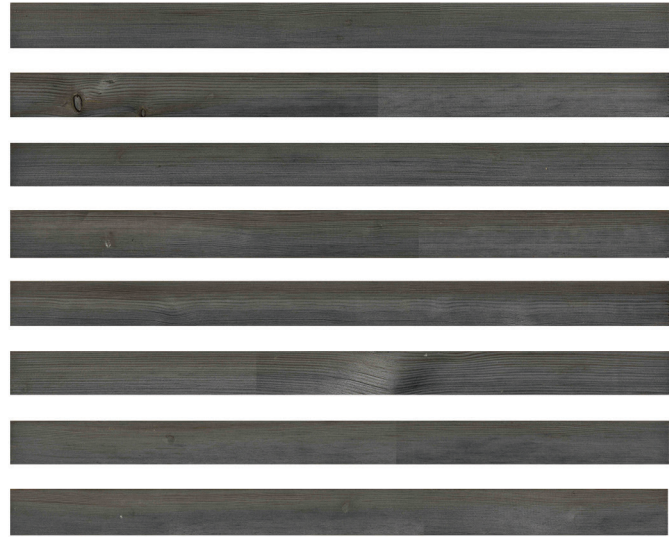

Figure 4.41 Cladding 5S. Color development after 20 months of exposure to weather at the Voll research fields in Trondheim, Norway.



Face 2



5S2

5S4

5S6

5S8

5S10

5S12

5S14

5S16



Color of the newly planed wood surface.

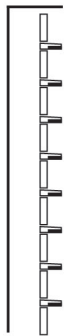

Face 4



5S2

5S4

5S6

5S8

5S10

5S12

5S14

5S16

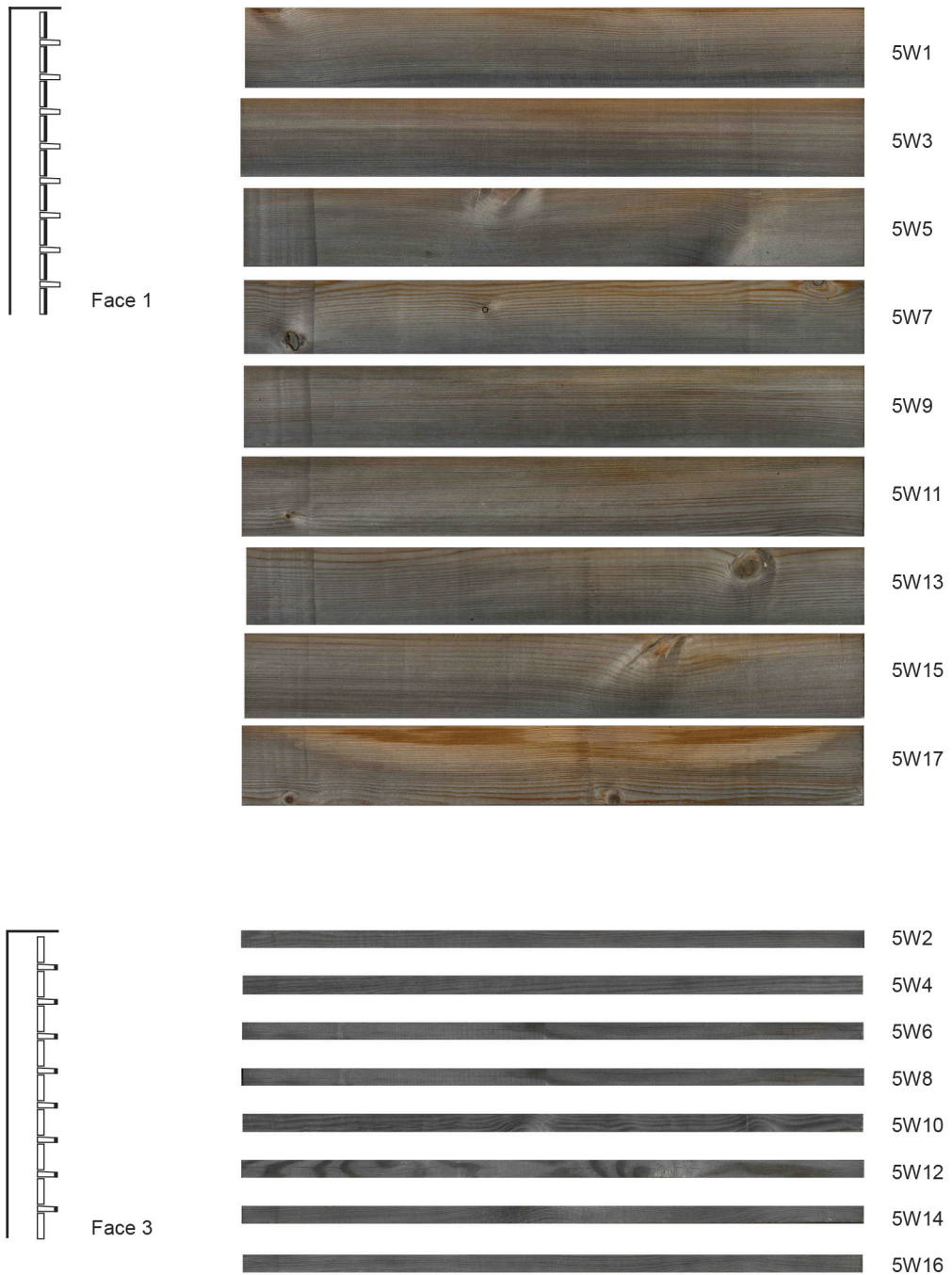
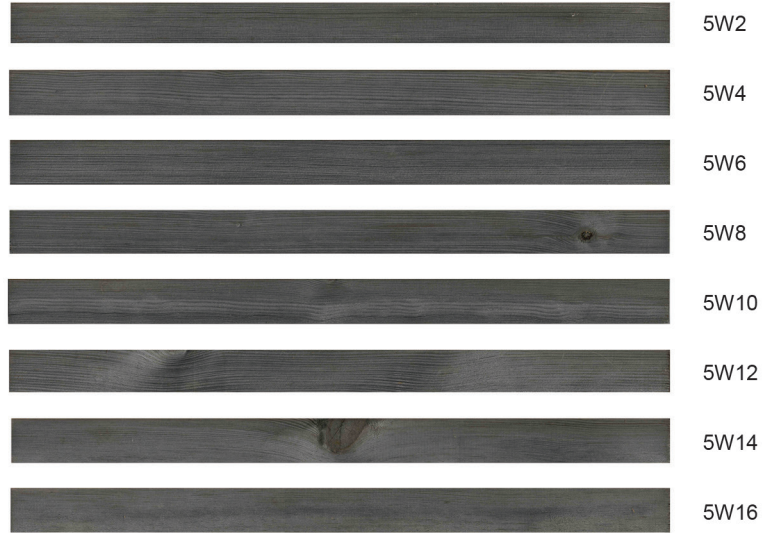

Figure 4.42 Cladding 5W. Color development after 20 months of exposure to weather at the Voll research fields in Trondheim, Norway.



Face 2



Color of the newly planed wood surface.

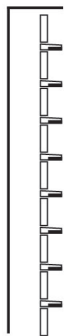

Face 4



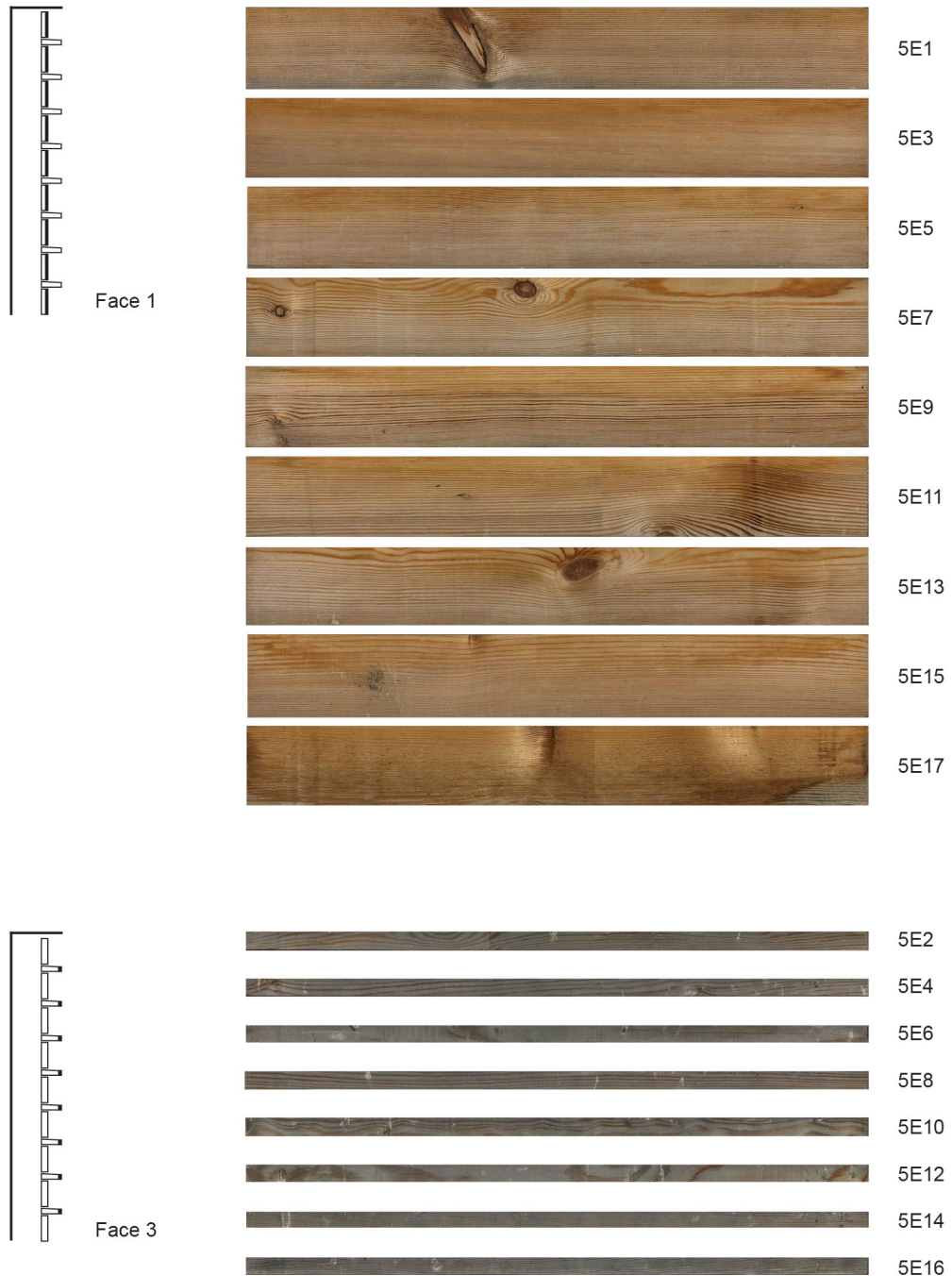
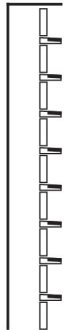

Figure 4.43 Cladding 5E. Color development after 20 months of exposure to weather at the Voll research fields in Trondheim, Norway.



Face 2



5E2



5E4



5E6



5E8



5E10



5E12



5E14



5E16



Color of the newly planed wood surface.

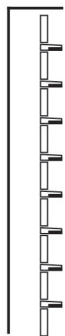

Face 4



5E2



5E4



5E6



5E8



5E10



5E12



5E14



5E16

4.8 Cladding 6

Fig. 4.44 shows an overview of the color development of the four samples of Cladding 6 displayed in groups of the individual surfaces and as the pattern repeat. For details of the color development please refer to Figs. 4.48–4.51. Figs. 4.45–4.47 show the weather maps modeled for Cladding 6.

4.8.1 Weathering color pattern

Claddings 6 and 5 largely share the same geometrical features, except that Cladding 6 was designed with protruding horizontal boards twice the depth of those of Cladding 5. Comparing the surfaces of Cladding 6, Fig. 4.44 with corresponding surfaces of Cladding 5, Fig. 4.36 shows that the color development of Cladding 6 is very similar to that of Cladding 5.

4.8.2 Analysis of the color development

The color differences between Claddings 6 and 5 are most distinct on Face 1. The grey color appears lighter and covers a smaller area of the lower part of Face 1 of Cladding 6 compared to that of Face 1 of Cladding 5.

The directional and spherical weather maps, Figs. 4.46 and 4.47 for Faces 1 and 2 of Cladding 6 compared to corresponding maps for Cladding 5 Figs. 4.38 and 4.39 demonstrate how the angle openings towards weather narrows as the relief deepens. The angle openings towards weather for Faces 3 and 4 are identical for Claddings 6 and 5.

The surface weather maps for Cladding 6, Fig. 4.45 compared to the surface weather maps for Cladding 5, Fig. 4.37 show that the amount of WDR, UV and sun hours modeled for Cladding 6, Faces 1 and 2 is lower than corresponding surfaces of Cladding 5, Faces 1 and 2. This is the result of the shade created by the extended length of the protruding horizontal boards. It appears that the color development caused by the increased depth of Cladding 6 compared to that of Cladding 5 exhibits the same tendencies as was seen when comparing the color development of Cladding 3 with that of Cladding 2: the narrowing of the angle openings towards weather caused by the increased depth result in lower amounts of WDR incident on the rear areas of the deeper relief claddings. Exposure to lower amounts of WDR resulted in slower rate of grey color development on the rear part of the deeper relief claddings. In the case of Cladding 6, a slower rate of grey development was found on Face 1 and the rear part of Face 2.

4.8.3 Edge effects

The edge effects on Cladding 6 are similar to those seen on Cladding 5.

4.9 Cladding 7

Cladding 7 was removed from the experiment. There was some suspicion that an exchange may have occurred during removal and experimentation with ways to document cladding coloring; it is thought that 7W may have been unintentionally exchanged with 7E.

CHAPTER 4: RESULTS AND DISCUSSION

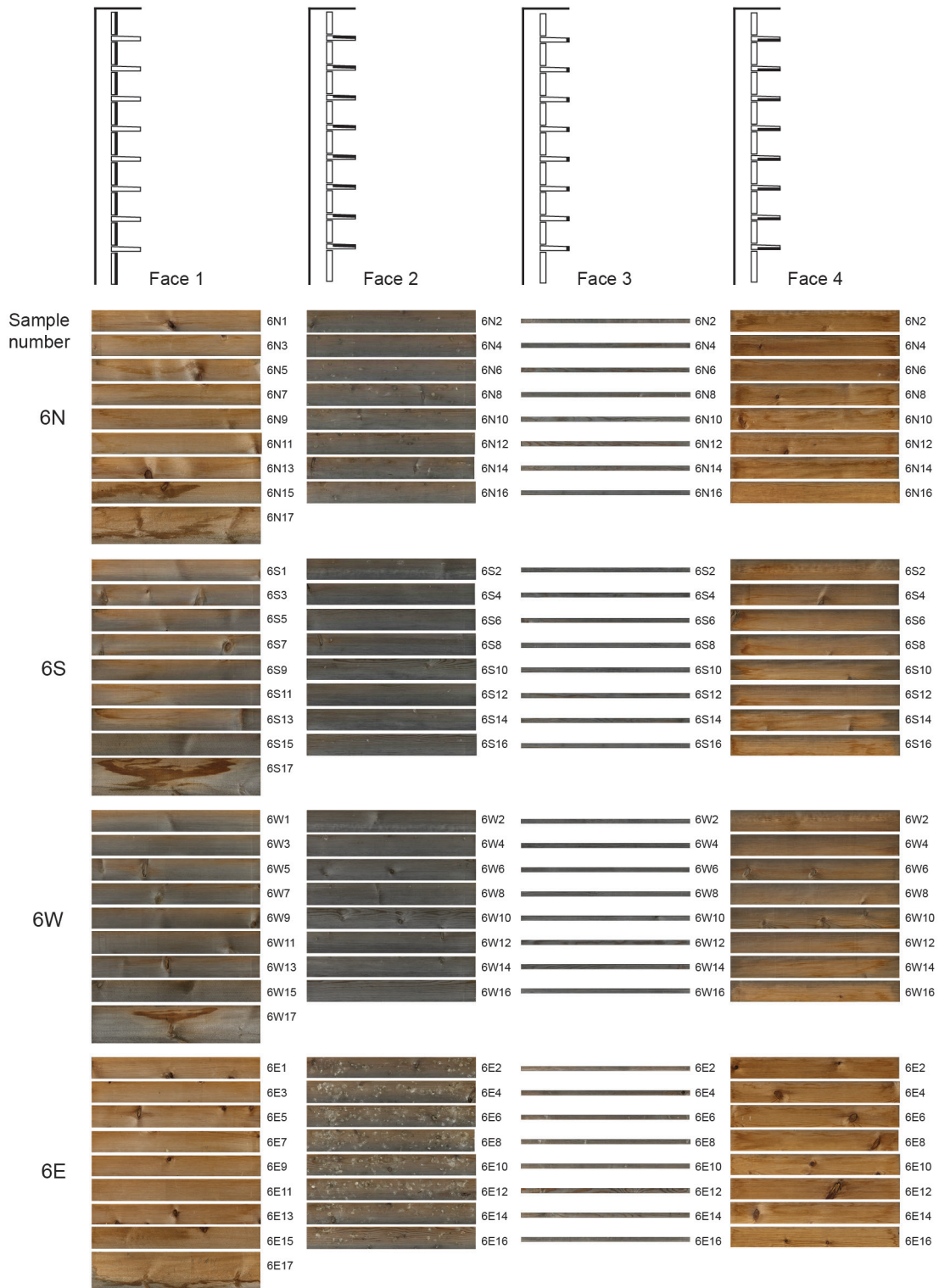
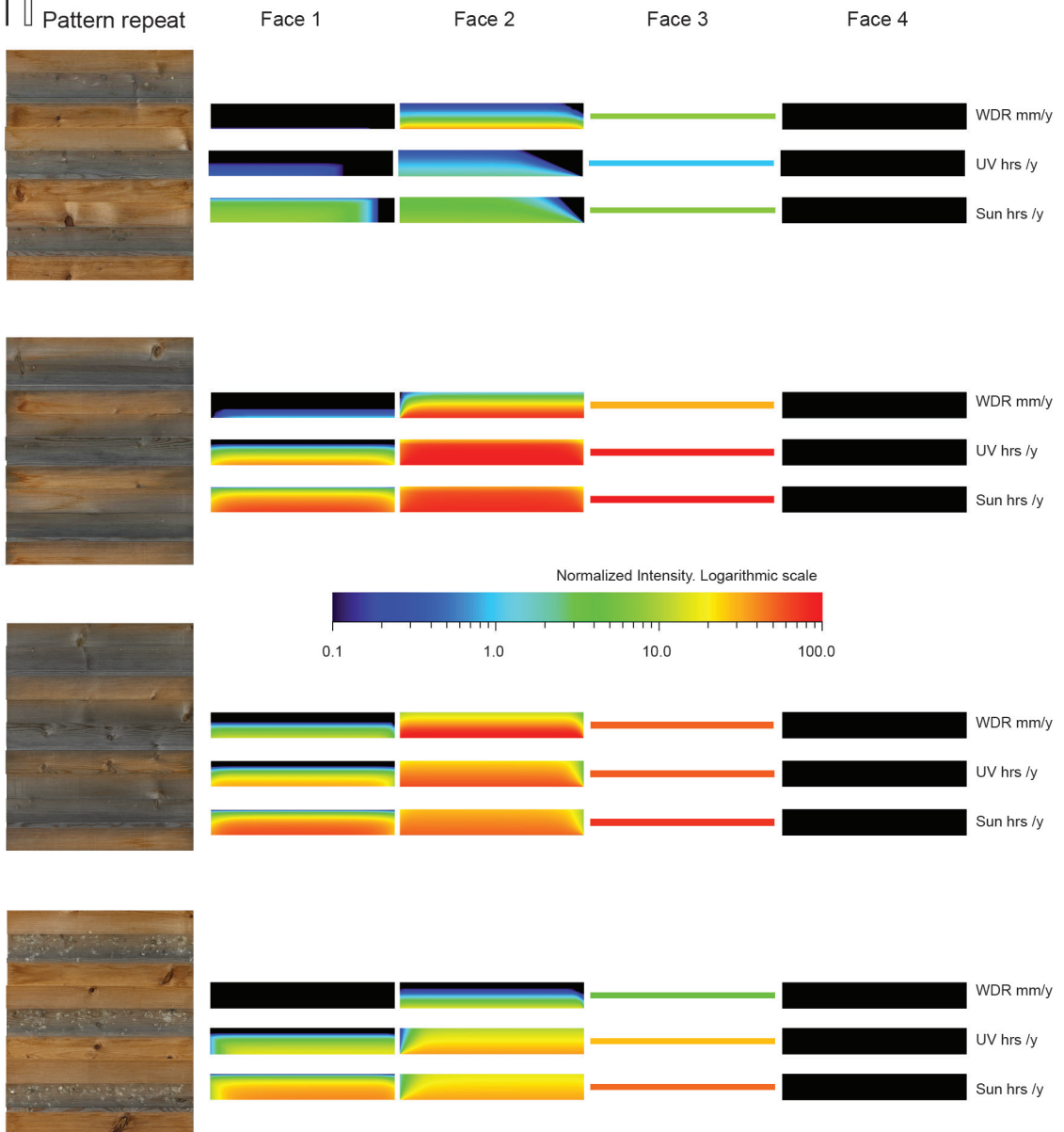



Figure 4.44 Left side. Cladding 6. Weathering colors of the four samples after 20 months of exposure to weather at the Voll research fields in Trondheim. Displayed in groups of the individual surfaces and as the pattern repeat.

Figure 4.45 Below. Cladding 6. Surface Weather Maps.



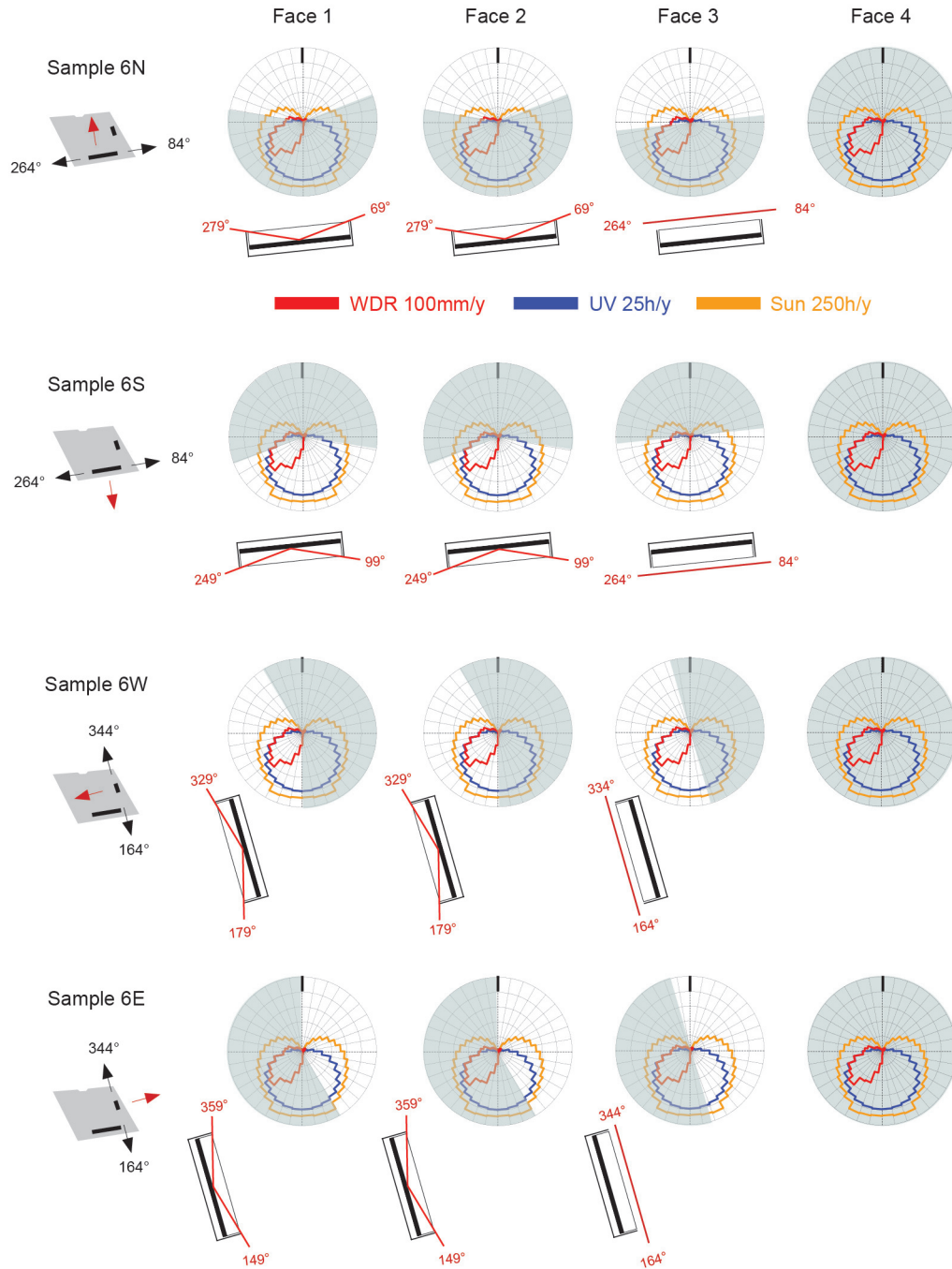

Figure 4.46 Cladding 6. Directional weather maps for the individual surfaces of Cladding 6. The white areas indicate sectors corresponding to the angle openings of the surfaces.

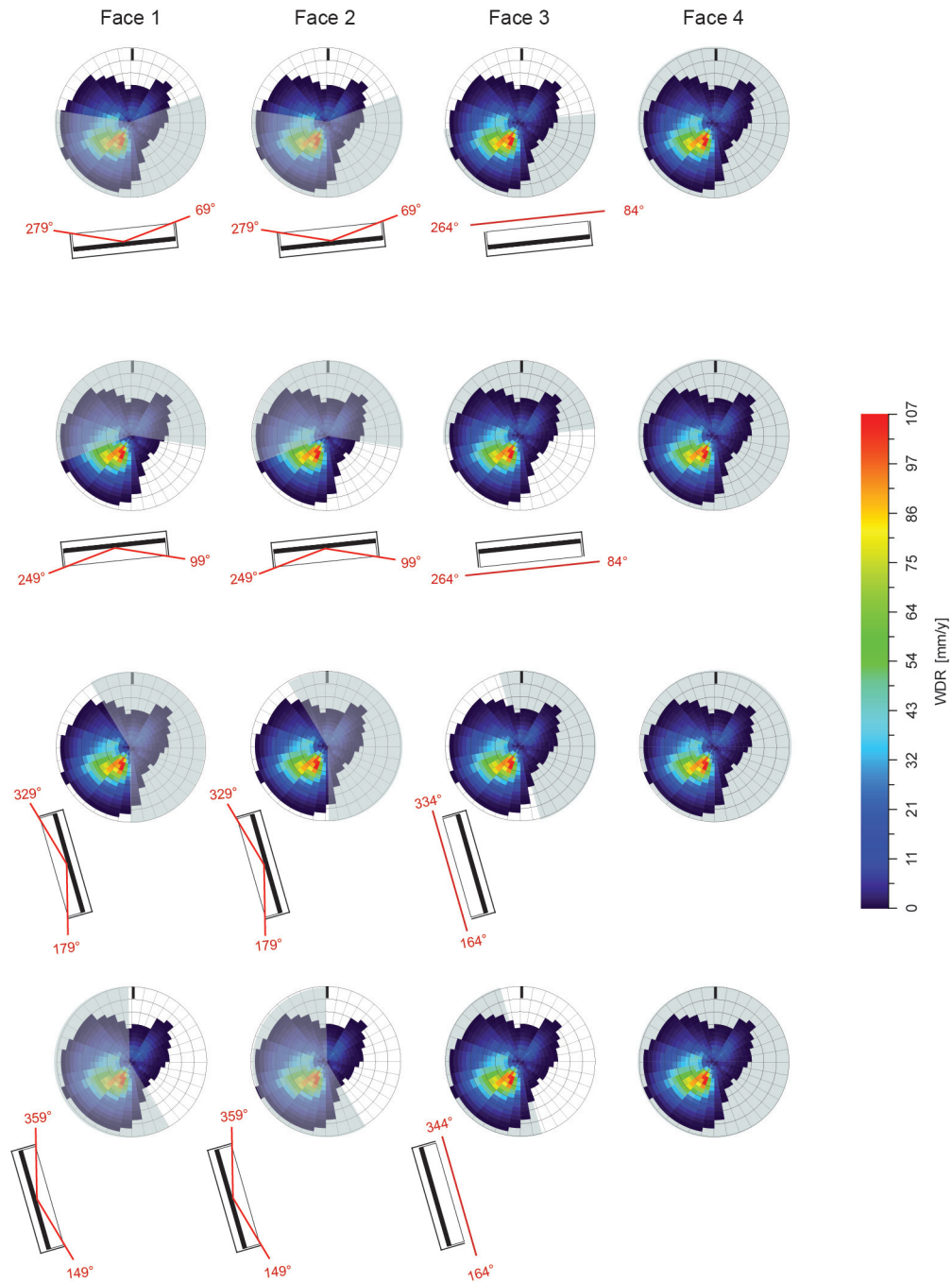

Figure 4.47 Cladding 6. Spherical weather maps for the individual surfaces of Cladding 6. The white areas indicate sectors corresponding to the angle openings of the surfaces.

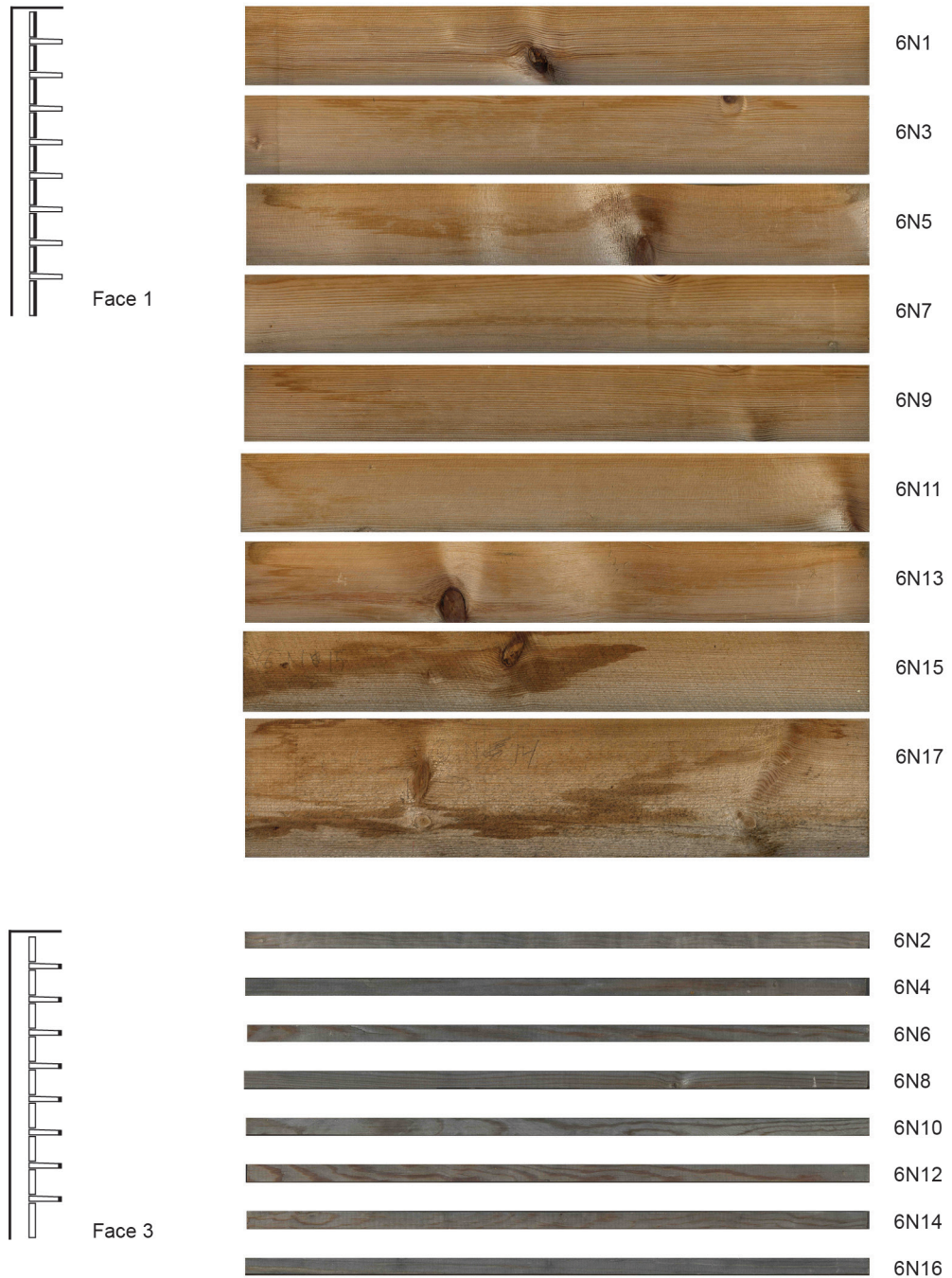
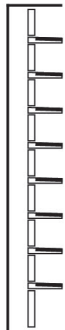

Figure 4.48 Cladding 6N. Color development after 20 months of exposure to weather at the Voll research fields in Trondheim, Norway.



Face 2



6N2



6N4



6N6

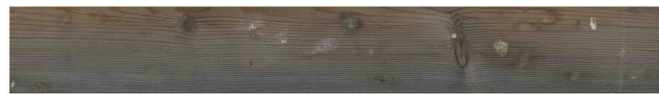

6N8

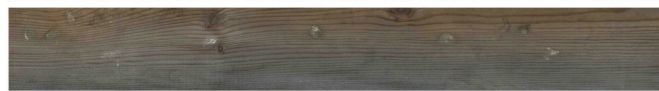

6N10



6N12



6N14



6N16

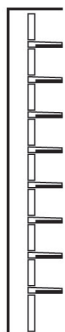

Face 4



6N2

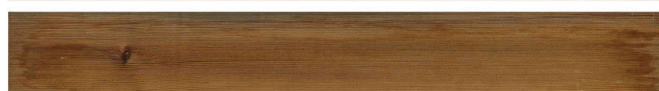

6N4

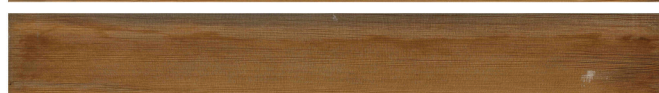

6N6



6N8



6N10



6N12



6N14



6N16

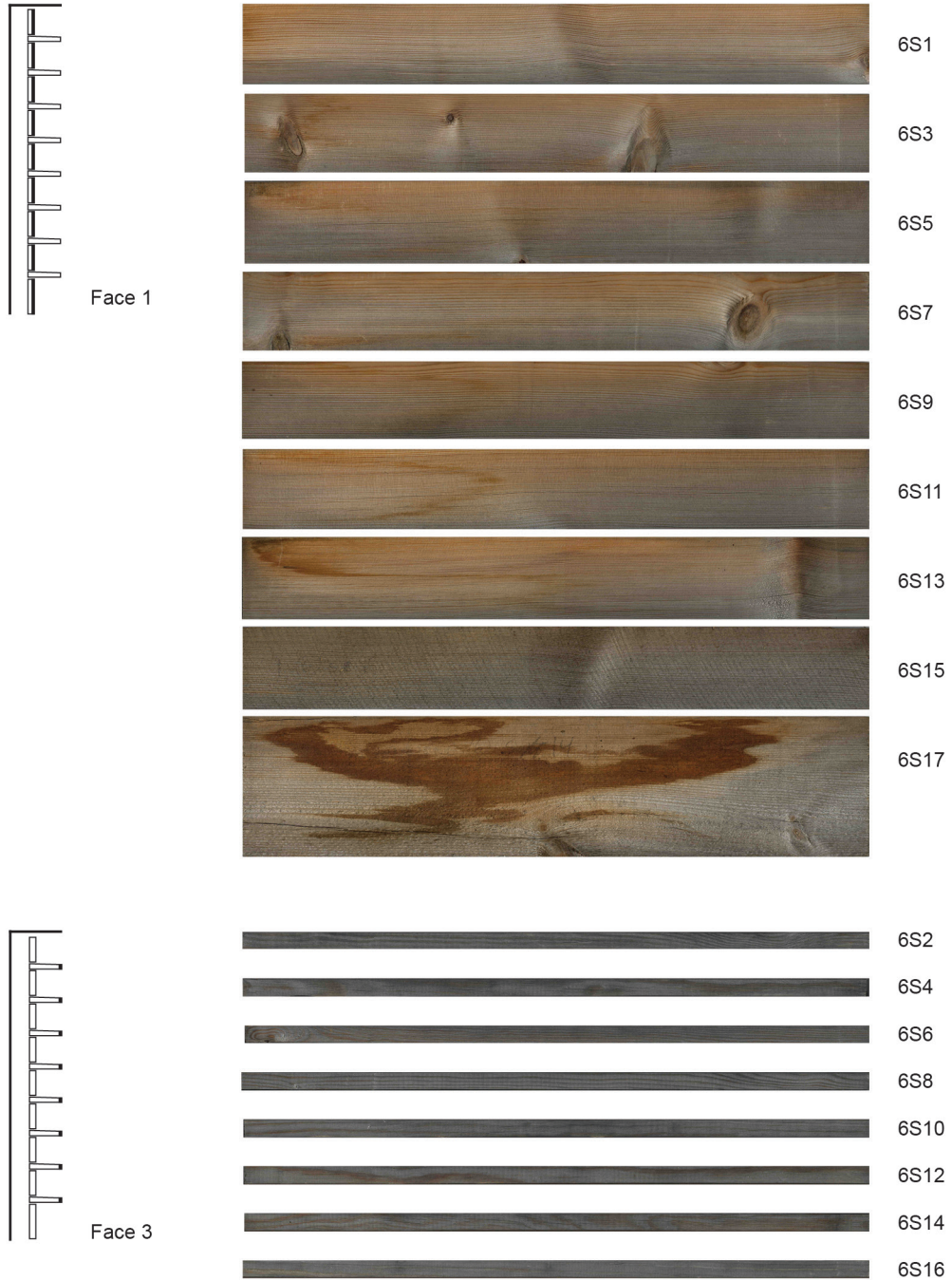
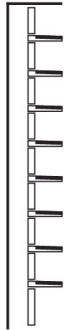

Figure 4.49 Cladding 6S. Color development after 20 months of exposure to weather at the Voll research fields in Trondheim, Norway.



Face 2



6S2



6S4



6S6



6S8



6S10

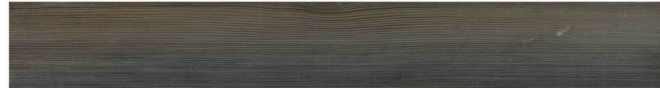

6S12



6S14



6S16



Face 4



6S2



6S4



6S6



6S8



6S10



6S12



6S14



6S16

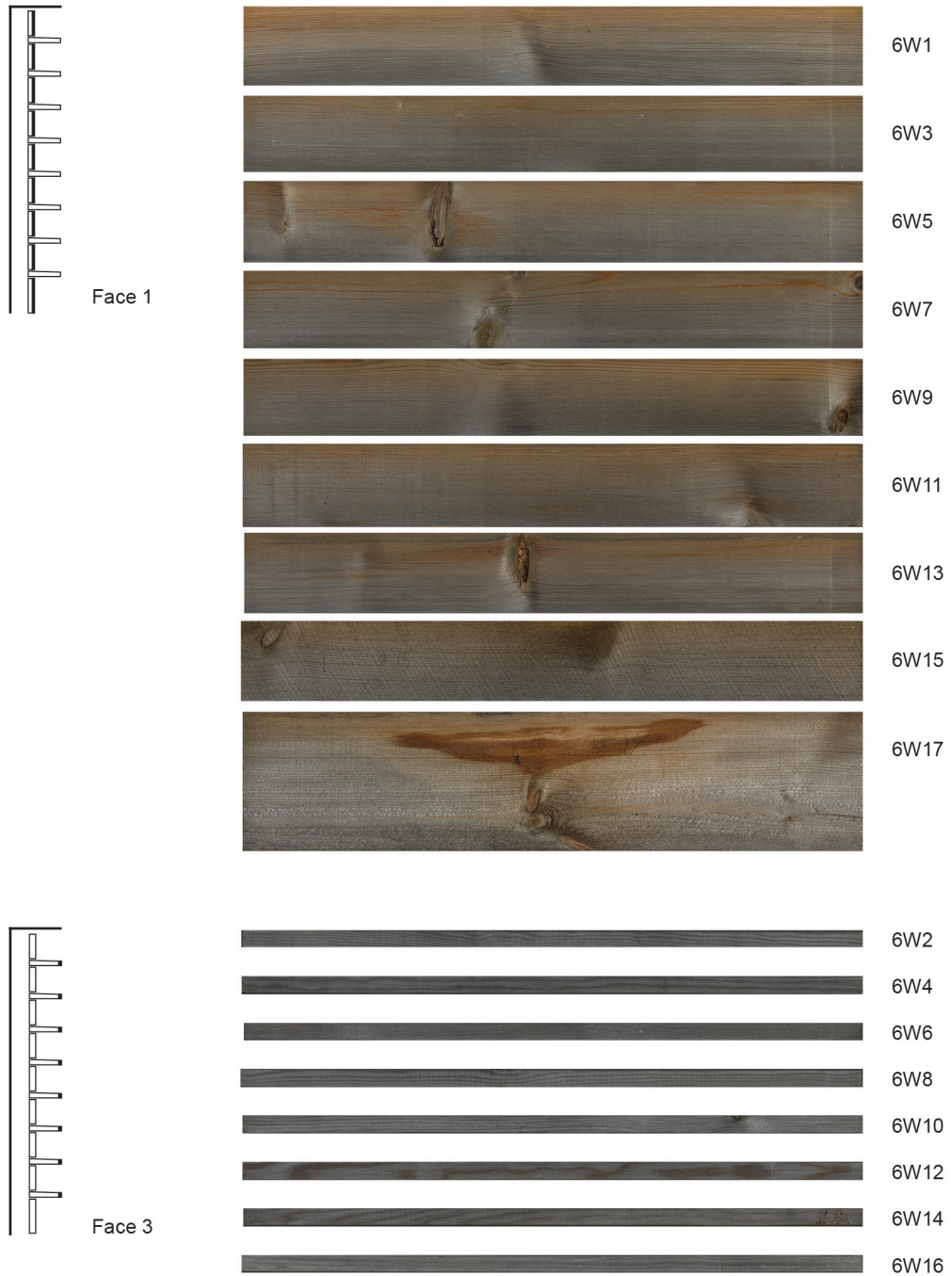
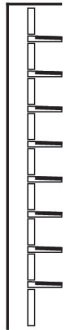

Figure 4.50 Cladding 6W. Color development after 20 months of exposure to weather at the Voll research fields in Trondheim, Norway.



Face 2



6W2



6W4



6W6



6W8



6W10



6W12



6W14

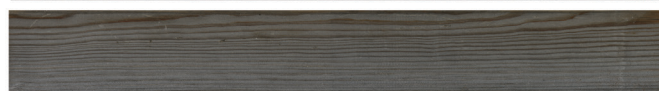

6W16



Face 4



6W2



6W4



6W6

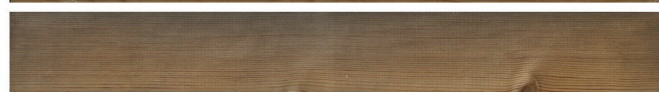

6W8



6W10



6W12



6W14



6W16

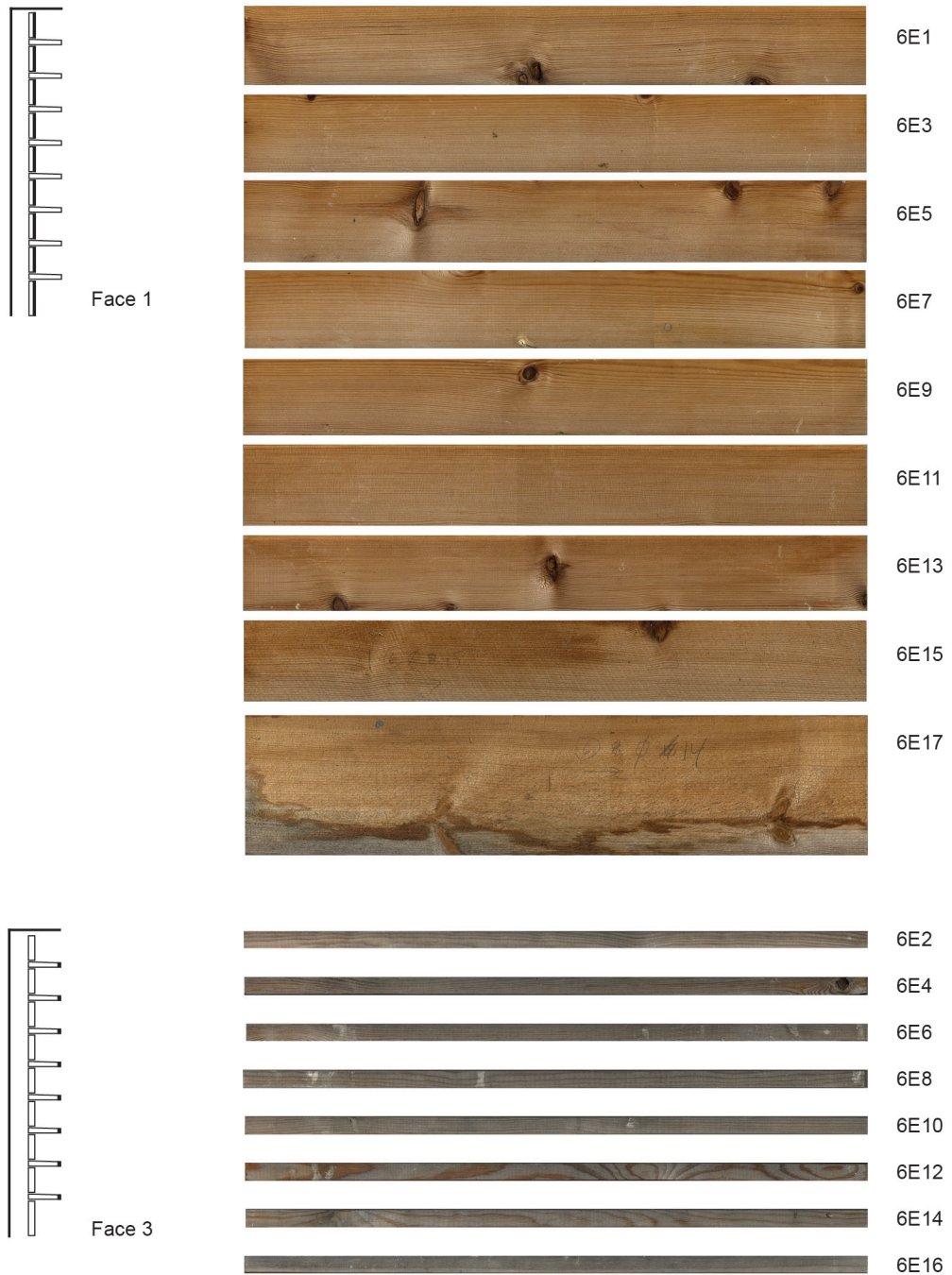
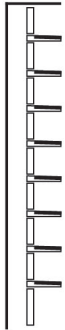

Figure 4.51 Cladding 6E. Color development after 20 months of exposure to weather at the Voll research fields in Trondheim, Norway.



Face 2



6E2

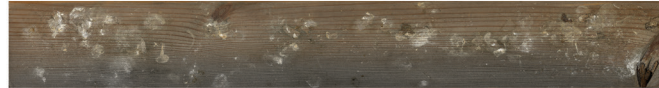

6E4



6E6



6E8



6E10



6E12



6E14



6E16

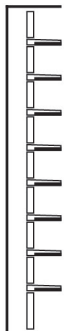

Face 4



6E2



6E4



6E6



6E8

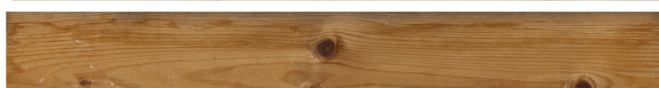

6E10

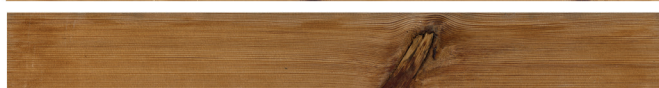

6E12



6E14



6E16

4.10 Cladding 8

Fig. 4.52 shows an overview of the color development of the weather- and construction sides of the four samples of Cladding 8. For details of the color development please refer to Figs. 4.56–4.59. Figs. 4.53–4.55 show the weather maps modeled for Cladding 8.

4.10.1 Weathering color pattern

The weather side surfaces of all four samples of Cladding 8 have developed a similar type of color pattern characterized by grey on the lower and brown with extractives on the upper part of the boards. The extent of the grey and brown areas varies on the four samples.

8W has developed the largest grey coverage and a small line of brown with extractives on the upper edges.

8S has a slightly smaller area of grey and a proportionally larger area of brown with extractives on the upper part of the boards compared to 8W.

8N and 8E have the smallest grey coverage and appear rather similar. The extractive deposits cover the upper half and are considerable.

The construction side surfaces of the four samples have also developed similarities in the color development characterized by a pattern of grey-brown on the lower and brown on the upper part of the boards. A line of extractives has developed in the border region between the grey and brown color. 8N and 8E appear very similar in the color nuances and pattern. Likewise 8S and 8W appear similar in color and pattern. 8S and 8W are darker grey than 8N and 8E. Board 8S3 is lighter brown than the remaining surfaces of sample 8S. This surface was planed, whereas the remaining construction side surfaces of the four samples were unplanned.

4.10.2 Analysis of the color development

This cladding type is characterized by inclined boards that overlap. Every overlapping board creates shade on the uppermost part of the board right below it. The cladding has a weather side and a construction side. The weather side surfaces are exposed to higher amounts of WDR, UV and sun hours than vertically positioned surfaces such as on Claddings 1 and 4, due to the inclined position towards the sky. By contrast, the construction side surfaces are fully shaded.

Weather side surfaces

The directional weather maps, Fig. 4.54 show that 8W and 8S were facing the main WDR direction at Voll whereas 8N and 8E were facing areas with low amounts of WDR. The spherical weather maps, Fig. 4.55 show that WDR falls in high amounts at low angles towards 8W and 8S and by contrast falls in low amounts at high angles towards 8N and 8E. The surface weather maps, Fig. 4.53 suggest a WDR exposure pattern of the weather side surfaces characterized by exposure to high amounts of WDR on the lower part of the boards and significantly lower amounts on the uppermost part of the boards. The amount of WDR towards 8W and 8S is significantly higher than towards 8N and 8E. This WDR exposure pattern agrees well with the color development of the four samples of Cladding 8.

Exposure to high amounts of WDR on the majority of the surface area explains the large coverage of grey color on 8W and 8S. Exposure to lower amounts of WDR on a

smaller area of the lower part of the boards explains the smaller area of grey color coverage on 8N and 8E.

The extractive deposits developed on the upper areas of the surfaces that were shaded by boards protruding from above. It appears likely that the extractives migrated from the lower WDR-exposed part of the surfaces to the drier upper areas where they were deposited. A similar pattern of grey on the lower, and brown with extractives on the upper part of the surfaces developed on Face 1 of Claddings 5 and 6, as seen in Figs. 4.36 and 4.44. Likewise, the surface weather maps for Face 1 of Claddings 5 and 6 suggest a WDR exposure pattern that resembles that of Cladding 8.

Construction side surfaces

The construction side surfaces were fully shaded, yet they too developed weathering colors. The color development of the construction side surfaces resembles that of the fully shaded Face 4 of Claddings 5 and 6 as seen in Figs. 4.36 and 4.44. In all cases the west and south facing samples developed more grey color, whereas the north and east facing samples developed more brown color. The grey color development of the fully shaded construction side surfaces can be explained by raindrop splash from the weather side surfaces that project to the above located construction side surface. The clearly more grey appearance of Samples 8W and 8S can be explained by exposure to higher amounts of WDR on the weather side surfaces that may cause more raindrop splash onto the construction side. By contrast the amount of WDR incident on the weather side of 8N and 8E were significantly lower which can explain why these surfaces appear browner.

The extractives can be explained by migration from the WDR-exposed weather side surfaces to the opposite drier construction side. It is also possible that wetting caused by raindrop splash contributed to the development of extractive deposits on the construction side. A similar color pattern developed on the equally fully shaded surfaces on Face 4 of Claddings 5 and 6.

Board 8S3 on the construction side was planed and appears clearly more brown than the remaining grey-looking planed surfaces of Sample 8S. This color variation indicates less favorable growth conditions for dark walled fungi compared to remaining unplaned surfaces. During the planing process, the surface is slightly compressed, which increases the wood density in the uppermost cell layers. Higher density material requires more water to reach a moisture content level above the fiber saturation point, which is a necessary condition for surface fungal growth.

4.10.3 Edge effects

It appears that the vertical plywood sides influenced the color development of the left and right hand side areas of both the weather and construction side surfaces. The left and right sides have more grey coverage compared to the central areas of the boards. This pattern was also present on Faces 1 and 4 of Claddings 5 and 6. Raindrop splash projecting from the vertical sides of the plywood frame, in combination with capillary suction in the end grain areas, are most likely the cause of the larger coverage of grey color on the left and right hand sides of the boards.

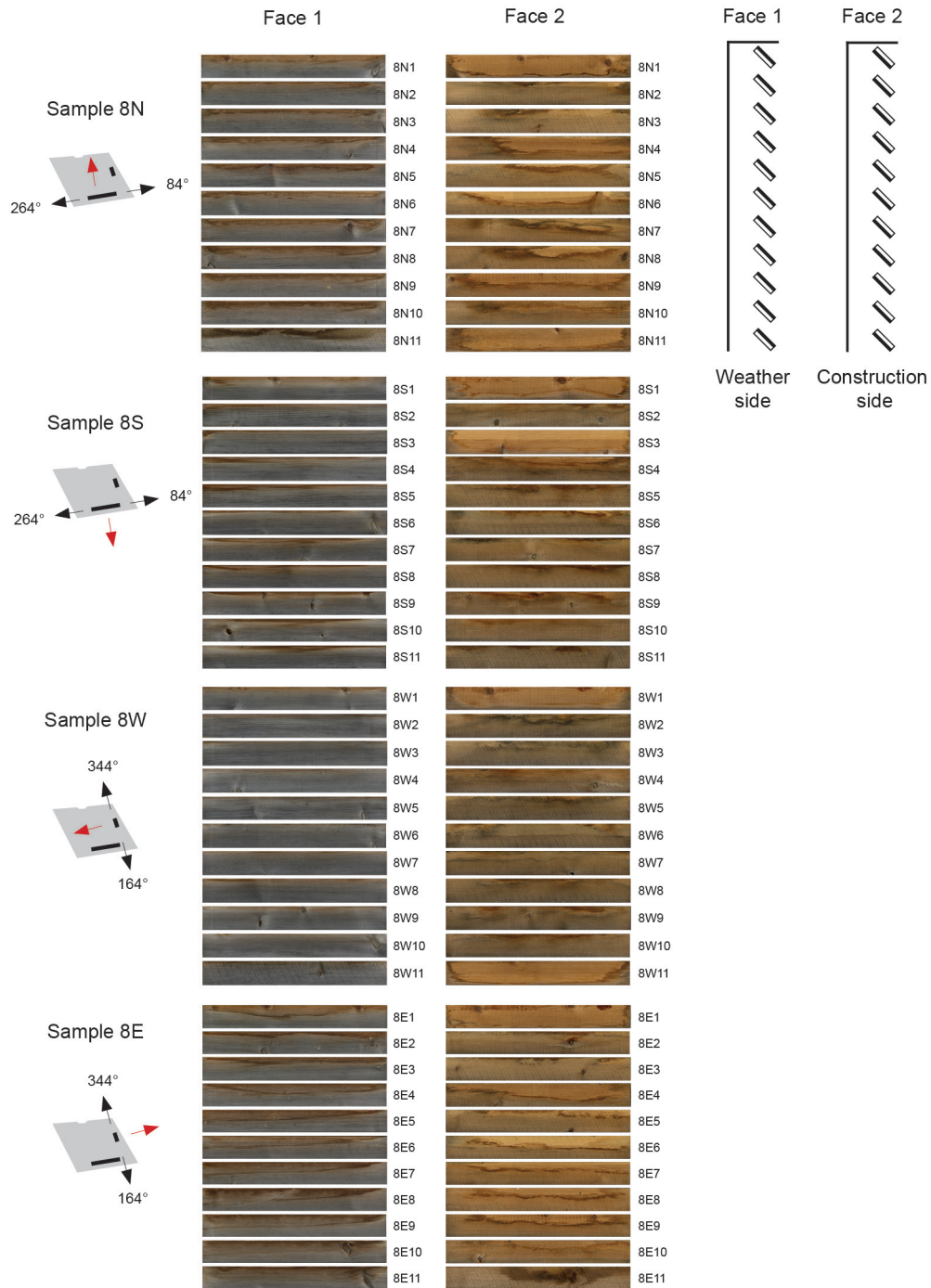

Figure 4.52 Cladding 8. Weathering colors of the four samples after 20 months of exposure to weather at the Voll research fields in Trondheim.

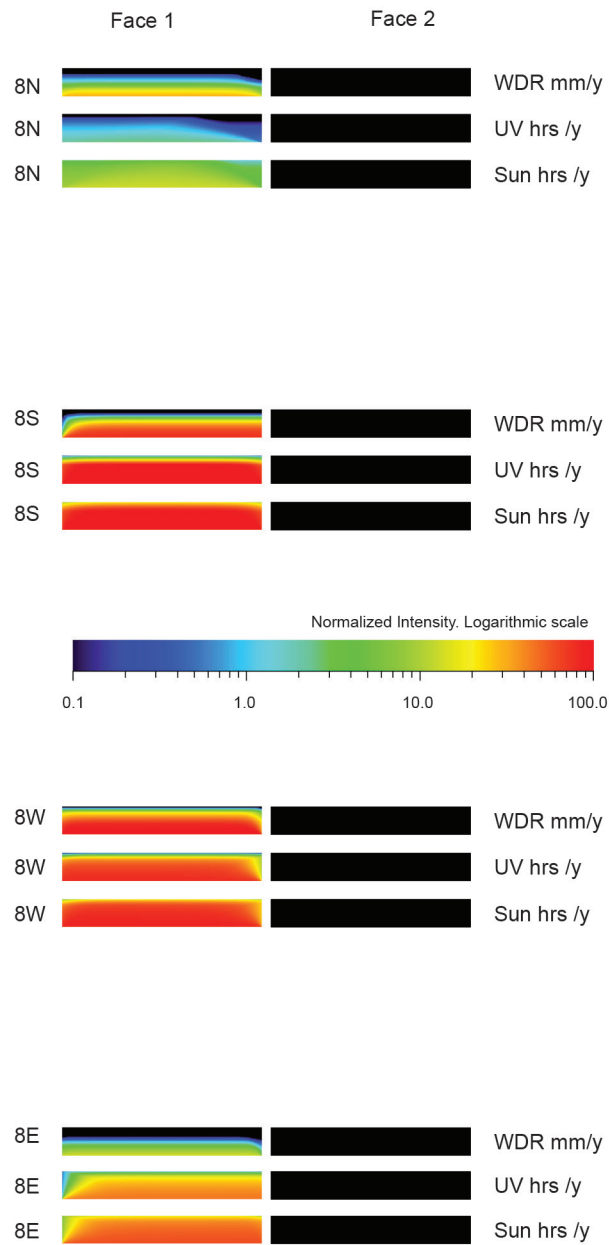

Figure 4.53 Cladding 8. Surface Weather Maps.

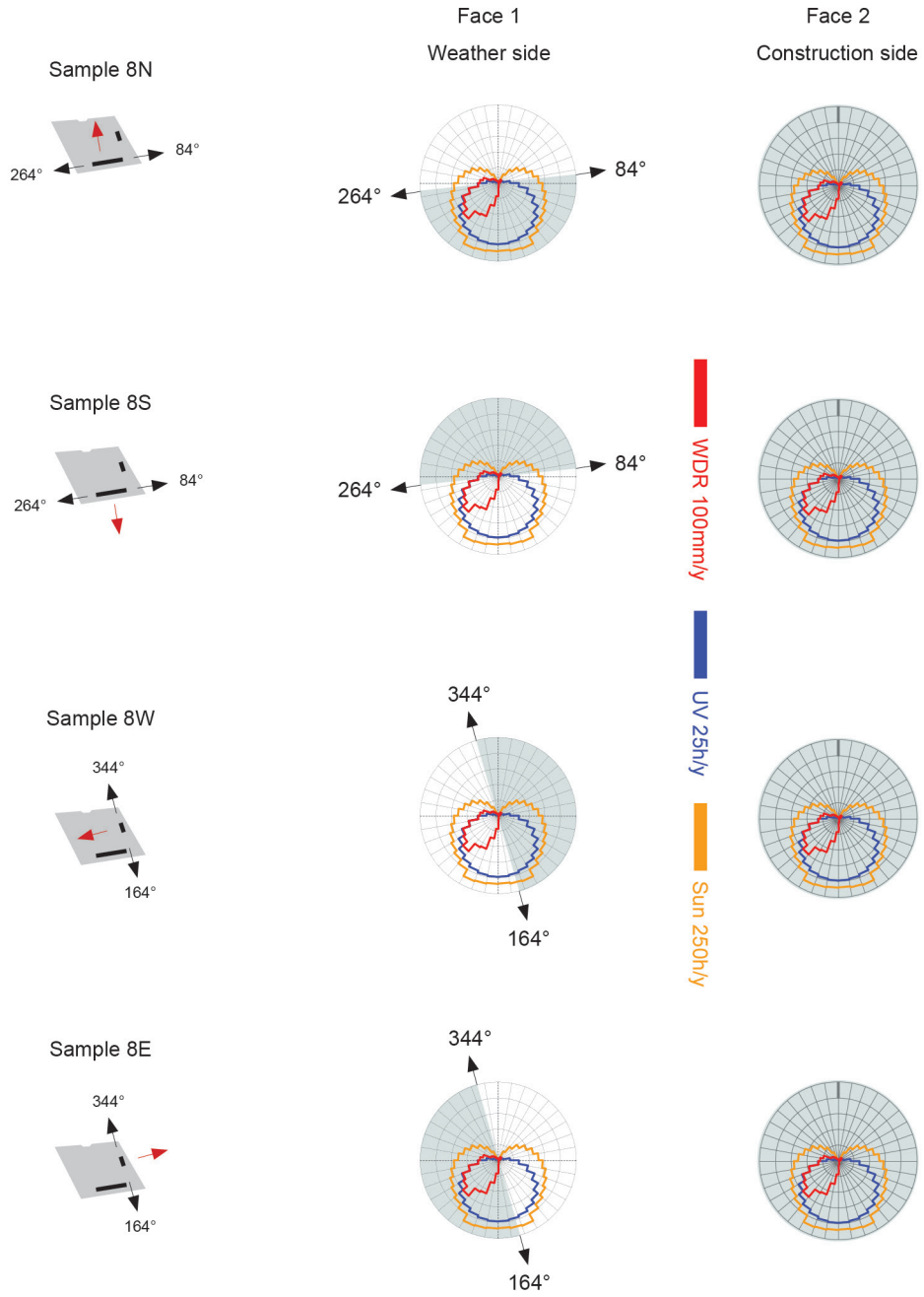

Figure 4.54 Cladding 8. Directional weather maps.

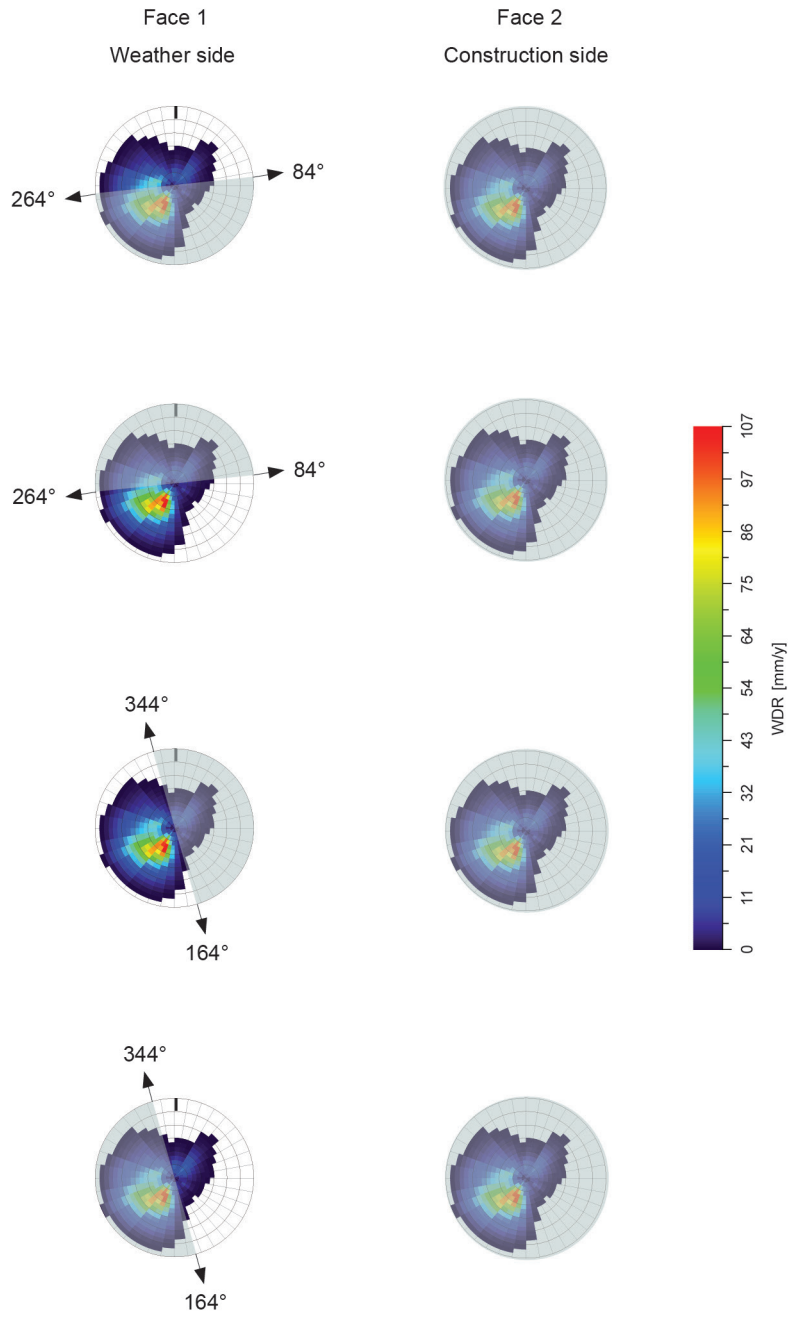

Figure 4.55 Cladding 8. Spherical weather maps.

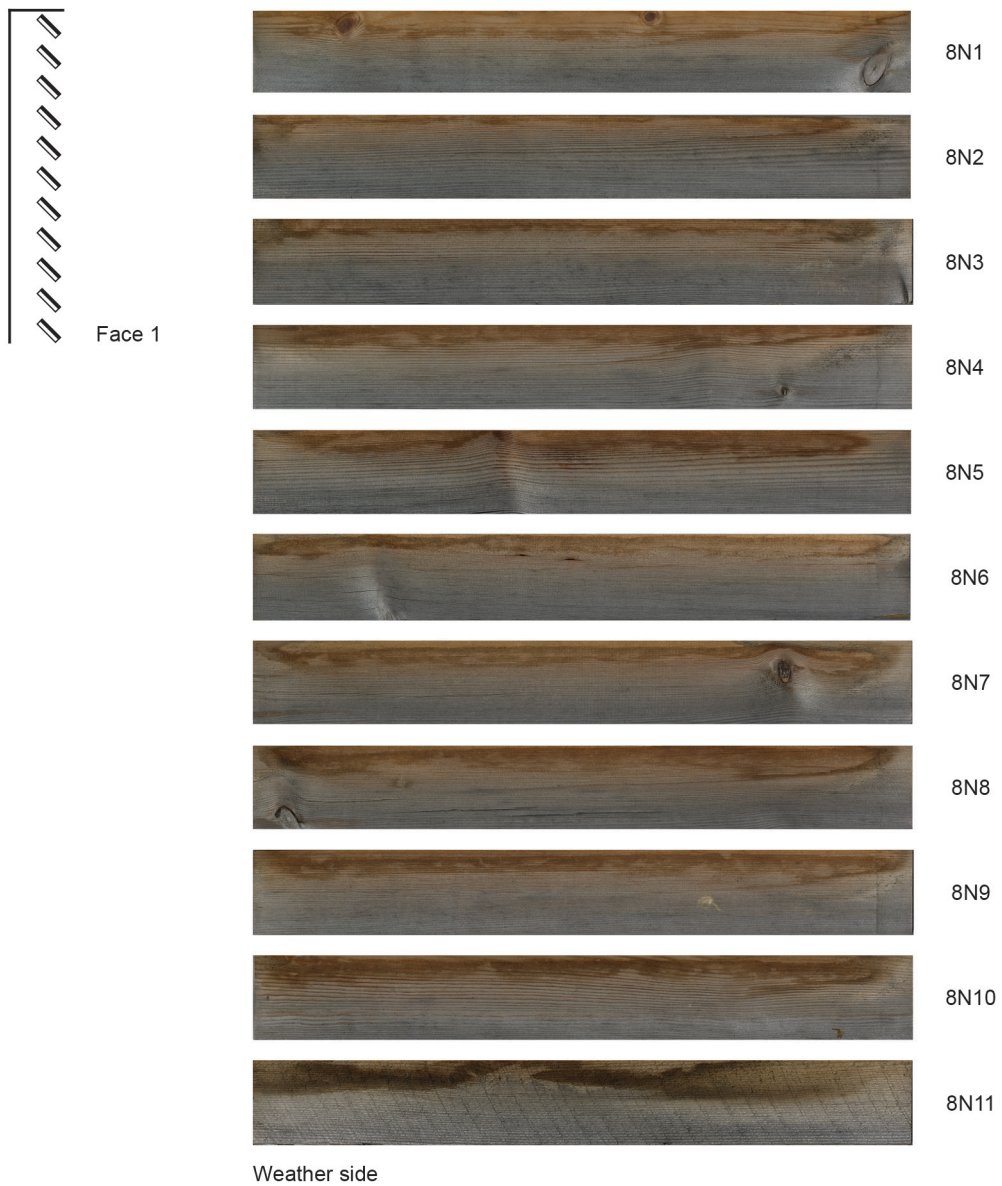
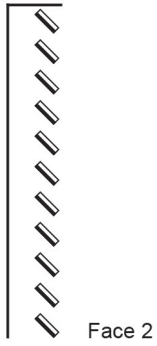

Figure 4.56 Cladding 8N. Color development after 20 months of exposure to weather at the Voll research fields in Trondheim, Norway.



8N1



8N2

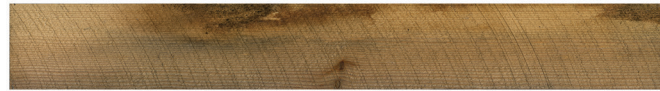

8N3



8N4



8N5



8N6



8N7



8N8



8N9



8N10



8N11

Construction side

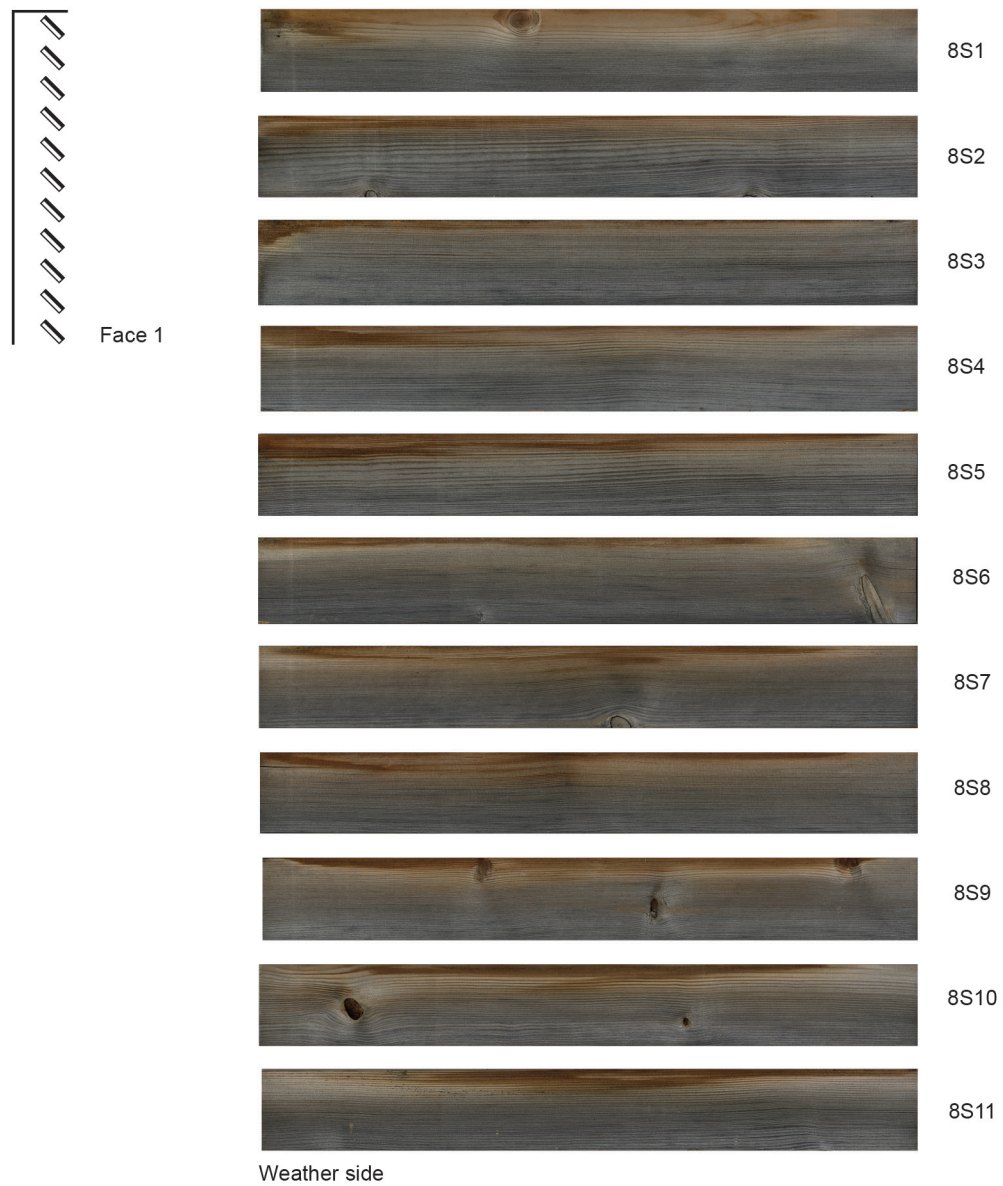

Color of the newly planed wood surface.

Figure 4.57 Cladding 8S. Color development after 20 months of exposure to weather at the Voll research fields in Trondheim, Norway.

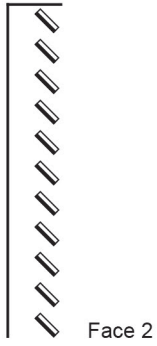

8S1



8S2



8S3



8S4

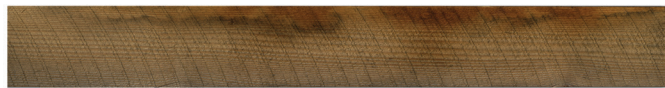

8S5



8S6



8S7



8S8



8S9



8S10



8S11

Construction side

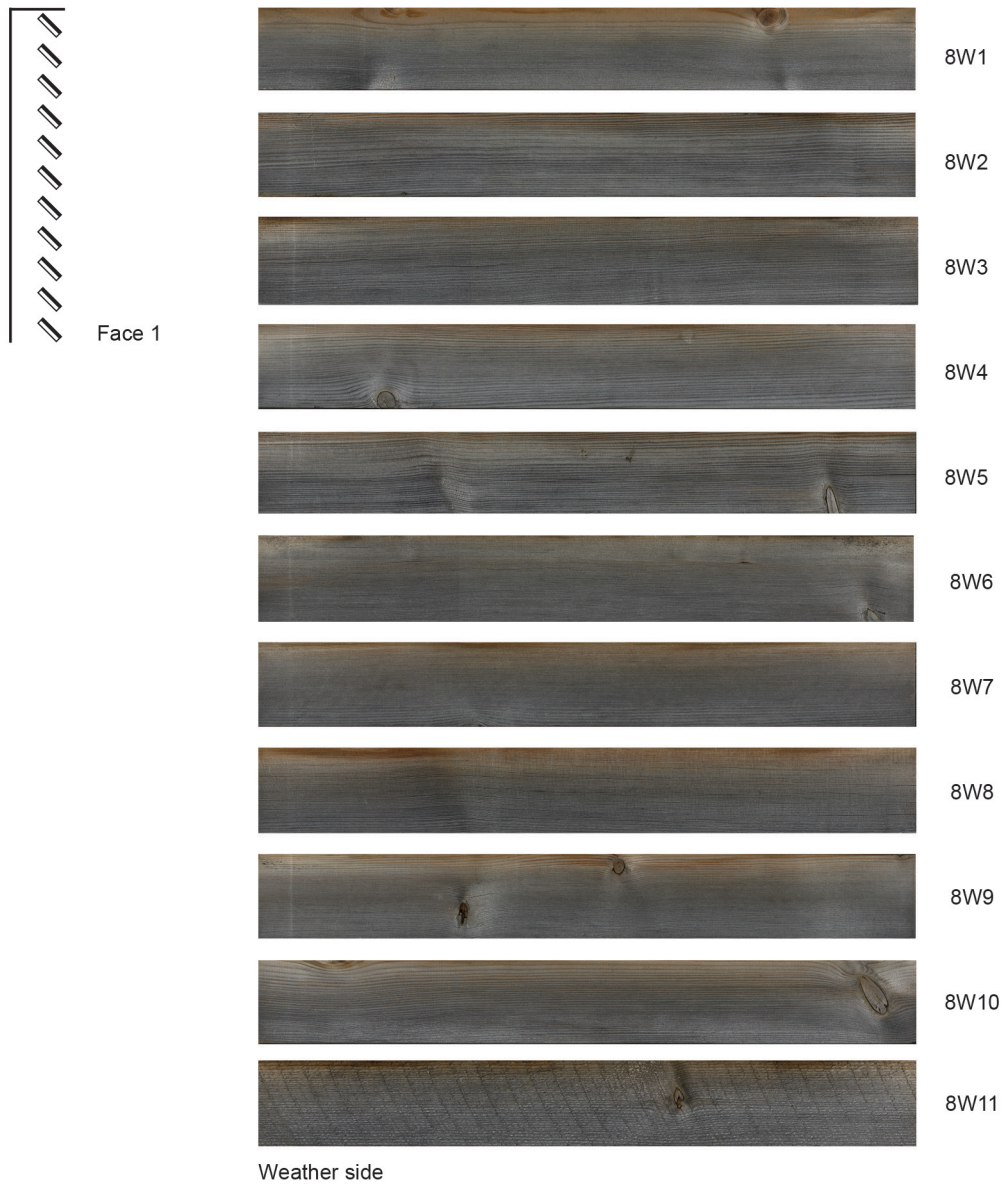
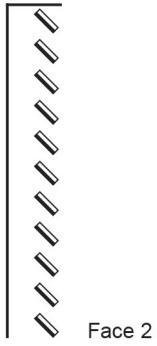

Figure 4.58 Cladding 8W. Color development after 20 months of exposure to weather at the Voll research fields in Trondheim, Norway.



8W1



8W2



8W3



8W4

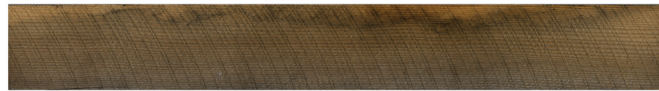

8W5



8W6



8W7



8W8



8W9



8W10



8W11

Construction side

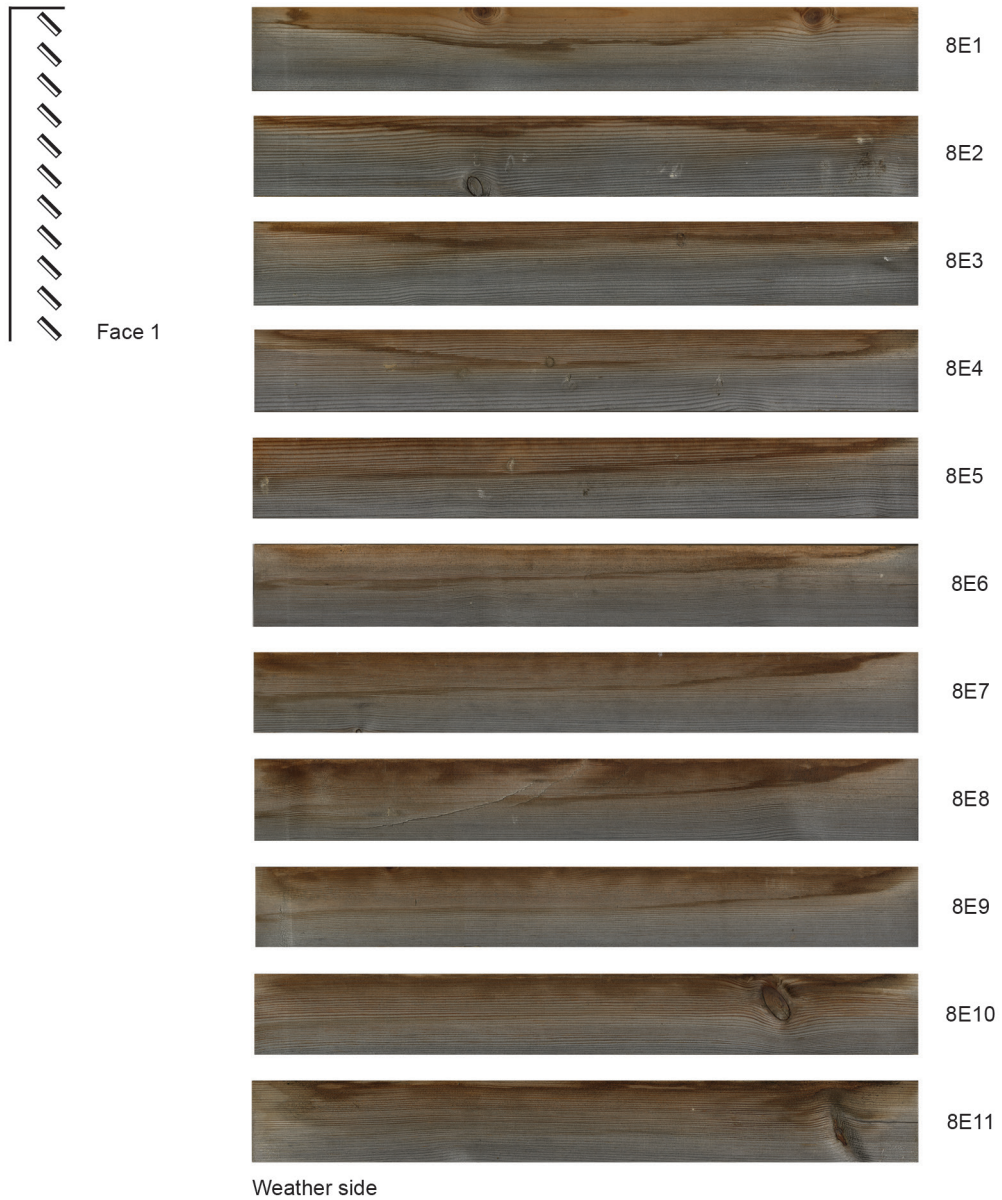
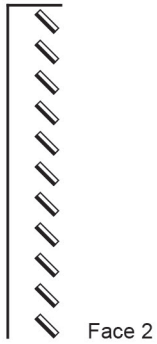

Figure 4.59 Cladding 8E. Color development after 20 months of exposure to weather at the Voll research fields in Trondheim, Norway.



8E1



8E2



8E3



8E4



8E5



8E6



8E7



8E8



8E9



8E10



8E11

Construction side

4.11 Summary of the color development of the claddings

4.11.1 Claddings 1 and 4

The geometry of Claddings 1 and 4 is characterized by a plane surface composed of vertical and horizontal boards respectively. This cladding type is non-shaded and weather has access to the total surface area. The four samples of Claddings 1 and 4 developed grey color at different rates. The darkest grey color was found on 1W, 4W, 1S and 4S. The fast dark grey color development agrees with exposure to the highest amounts of WDR at the experimental site at Voll. A lighter grey color developed on 1N and 4N, presumably due to exposure to a combination of low amounts of WDR, UV and sun hours. This provided longer TOW, which favored the surface fungal growth on these samples. 1E and 4E developed the lightest grey color of the four samples, which agrees well with exposure to a combination of low amounts of WDR and high amounts of UV and sun hours. This kept these surfaces very dry, thus retarding the surface fungal growth. The two-colored appearance of Claddings 1 and 4, and to a lesser extent of Samples 1W and 4W is the result of the presence of mixed sapwood and heartwood tissue.

4.11.2 Claddings 2 and 3

The geometry of Claddings 2 and 3 is characterized by vertically protruding boards. The boards of Cladding 3 have twice the depth of those of Cladding 2. The right and left hand sides of the protruding boards (Faces 2 and 4) have gradual shade from the outside to the rear of the surfaces, and create shade on Face 1. Face 3 is non-shaded. The right and left hand sides of the protruding boards in a cladding with this geometry face different areas of the horizon as demonstrated in the directional weather maps. This particular feature of the geometry allows for exposure to different types of weather incident on Faces 2 and 4. The experiment demonstrated that the cladding type has several different weathering color pattern potentials. In cases of exposure to WDR on one side and solar radiation on the other side of the protruding boards, these surfaces can develop grey on one and brown color on the opposite side. This is seen on Samples 2S, 3S, 2E and 3E. This type of cladding may also develop mono color grey in cases of exposure to rain on both sides of the protruding boards. This is seen on Sample 2W. Sample 3W also appeared to be experiencing a process of grey mono color development, however this was not clearly visible at the time of documenting the weathering colors. The weathering color patterns of 2N and 3N were heavily influenced by colors developed due to exposure to indirect water, which made the color pattern appear less distinct.

The four samples of Cladding 3 developed a color pattern very similar to corresponding samples of Cladding 2. The extended length of the protruding boards resulted in narrower angle openings towards weather, as illustrated in the directional weather maps. This resulted in exposure to lower amounts of weather incident on Face 1 and the rear halves of Faces 2 and 4. This was particularly visible on WDR-exposed surfaces that developed lighter grey compared to corresponding samples of Cladding 2.

The information in the directional weather maps agrees well with the color development of Claddings 2 and 3. Surfaces exposed to high amounts of WDR falling at low angles quickly developed grey color. This was seen on 2W, 3W and 2S, 3S Faces 1, 2 and 3. Surfaces exposed to low amounts of WDR falling at high angles developed grey at a slower rate as seen on 2N, 3N, 2E and 3E Faces 1, 3 and 4. Surfaces exposed to low amounts of WDR in combination with high amounts of UV and solar radiation developed brown color as seen on 2S and 3S Face 4 + 2E and 3E Face 2. The latter was only clearly recognizable in the photos taken after five years of exposure, Fig. 4.60.

4.11.3 Claddings 5 and 6

The geometry of Claddings 5 and 6 is characterized by horizontally protruding boards. The boards of Cladding 6 have twice the depths as those of Cladding 5. The protruding boards create significant differences in the shading conditions of the four surfaces of this cladding type. Faces 1 and 2 had differentiated shade, Face 3 is non-shaded, and Face 4 is fully shaded. The differences in the shading conditions resulted in significant color differences of the surfaces.

The four samples of Cladding 5 developed similarities in the color pattern. The color pattern of the four samples was characterized by a two-colored Face 1 that developed grey on the lower part and brown with extractives on the upper part, and grey colored Faces 2 and 3. Face 4 developed a grey to brown color with extractive deposits. The principal differences in the color development of the four samples of Cladding 5 were found on the two-colored Face 1, where the proportion of grey and brown vary significantly. The largest coverage of grey color was found on 5W and 5S, which agrees well with exposure to large amounts of WDR falling at low height angles as illustrated in the spherical weather maps. The smallest coverage of grey color was found on 5N and 5E, which agrees with exposure to low amounts of WDR falling at high height angles as illustrated in the spherical weather maps.

The four samples of Cladding 6 developed a color pattern very similar to corresponding samples of Cladding 5. The principal differences between corresponding samples of Cladding 5 and 6 was found on Face 1 where the grey color on the lower part of the surfaces was lighter and covered a smaller area on the four samples of Cladding 6 compared to Cladding 5. Longer protruding horizontal boards of Cladding 6 caused a narrower access of WDR to Face 1, resulting in a lighter grey color and coverage of a smaller area of the lower part of Face 1 of Cladding 6 compared to Face 1 of Cladding 5.

4.11.4 Cladding 8

The geometry of Cladding 8 is characterized by horizontally inclined boards that overlap. The overlap creates shade on the upper areas of the weather side boards resulting in a weathering color pattern characterized by grey on the lower part and brown with extractives above the grey area, right below the overlapping board. This weathering color pattern was found on all four samples. The proportion of grey and brown varies with the WDR exposure conditions. In the event of exposure to large amounts of WDR falling at low height angles, the grey area covered the larger part of the surfaces. In the

event of exposure to lower amounts of WDR falling at high angles the shading effect of the protruding boards was higher, resulting in a smaller area of grey and a larger area of extractive deposits.

4.12 Weathering colors after five years of exposure

Fig. 4.60 shows photos of Claddings 1-6 and 8 taken five years after the beginning of the experiment. These photos show that the tendencies in the color development after 20 months of exposure are to a large extent also discernible after five years of exposure

4.12.1 Claddings 1 and 4

Claddings 1 and 4 are a mono grey color. The mottled appearance of the surfaces stems from wasps rasping. It seems that the vertical mounted boards of Cladding 1 are more attractive to wasps than the horizontal boards of Cladding 4. Vertical rasping is perhaps the preferred working position for wasps?

4.12.2 Claddings 2 and 3

The color pattern that developed after 20 months of exposure is still clearly visible after five years of exposure. It is particularly noticeable that Samples 2S and 3S Face 4, as well as 2E and 3E Face 2 are still clearly brown with extractives.

4.12.3 Claddings 5 and 6

The pattern of the two-colored Face 1 of these claddings is still clearly visible after five years of exposure. It is noticeable that the extractive deposits on the upper area of Face 1 are clearly more visible on Cladding 5 than on corresponding surfaces of Cladding 6.

4.12.4 Cladding 8

The pattern of two-colored weather side surfaces is also recognizable on the four samples of Cladding 8. It appears that 8W is a mono grey color whereas 8N, 8S and 8E still clearly have streaks of extractives on the upper part of the surfaces.

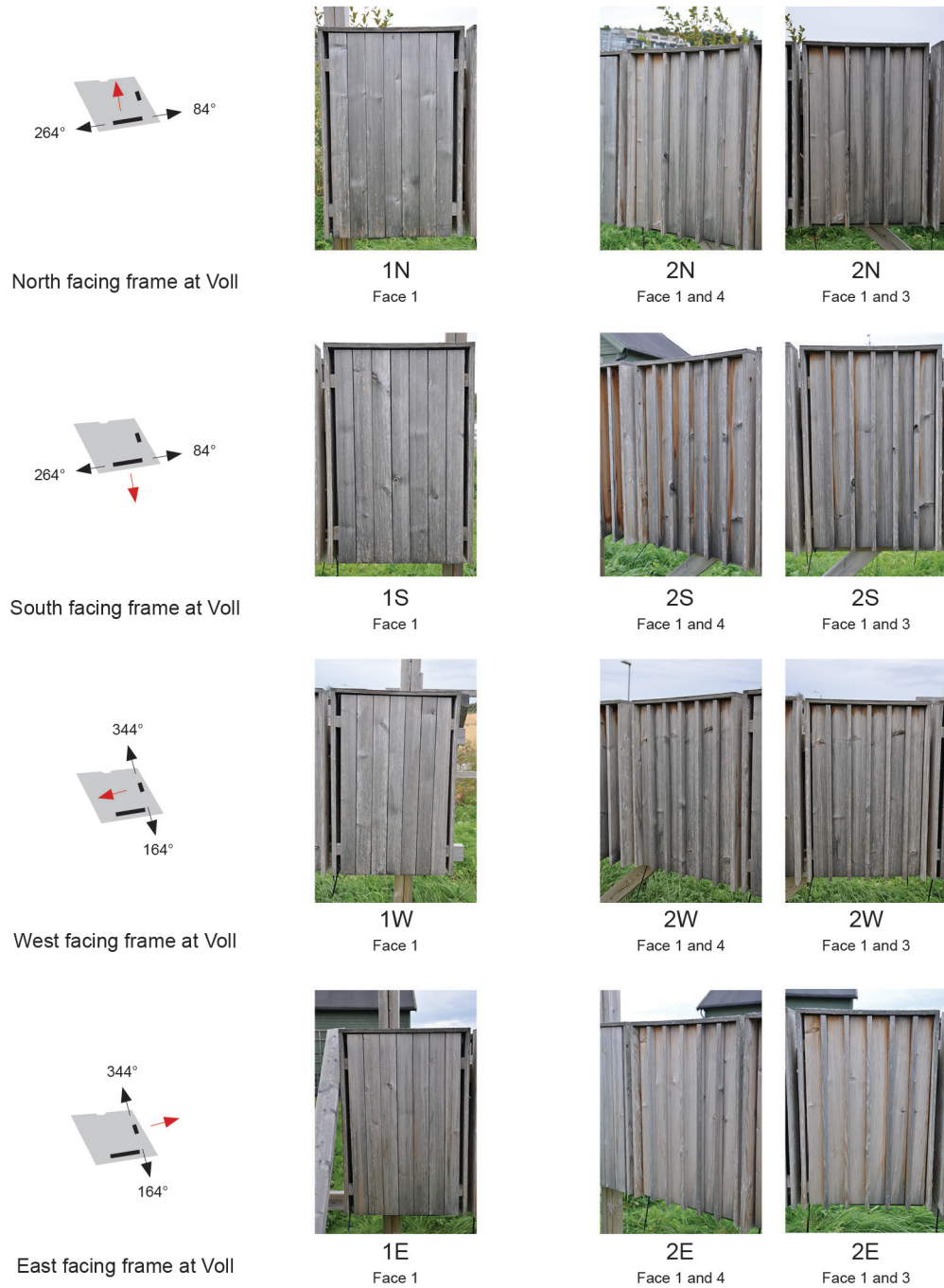

Figure 4.60 Claddings 1, 2 and 3. Color development after exposure to weather at the Voll research fields from February 11th 2006 to September 11th 2010. Claddings 4, 5, 6 and 8 are displayed on the next page. Photo © Majbrit Hirche.



2N
Face 1 and 2



3N
Face 1 and 4



3N
Face 1 and 3



3N
Face 1 and 2



2S
Face 1 and 2



3S
Face 1 and 4



3S
Face 1 and 3



3S
Face 1 and 2



2W
Face 1 and 2



3W
Face 1 and 4



3W
Face 1 and 3



3W
Face 1 and 2



2E
Face 1 and 2



3E
Face 1 and 4



3E
Face 1 and 3



3E
Face 1 and 2

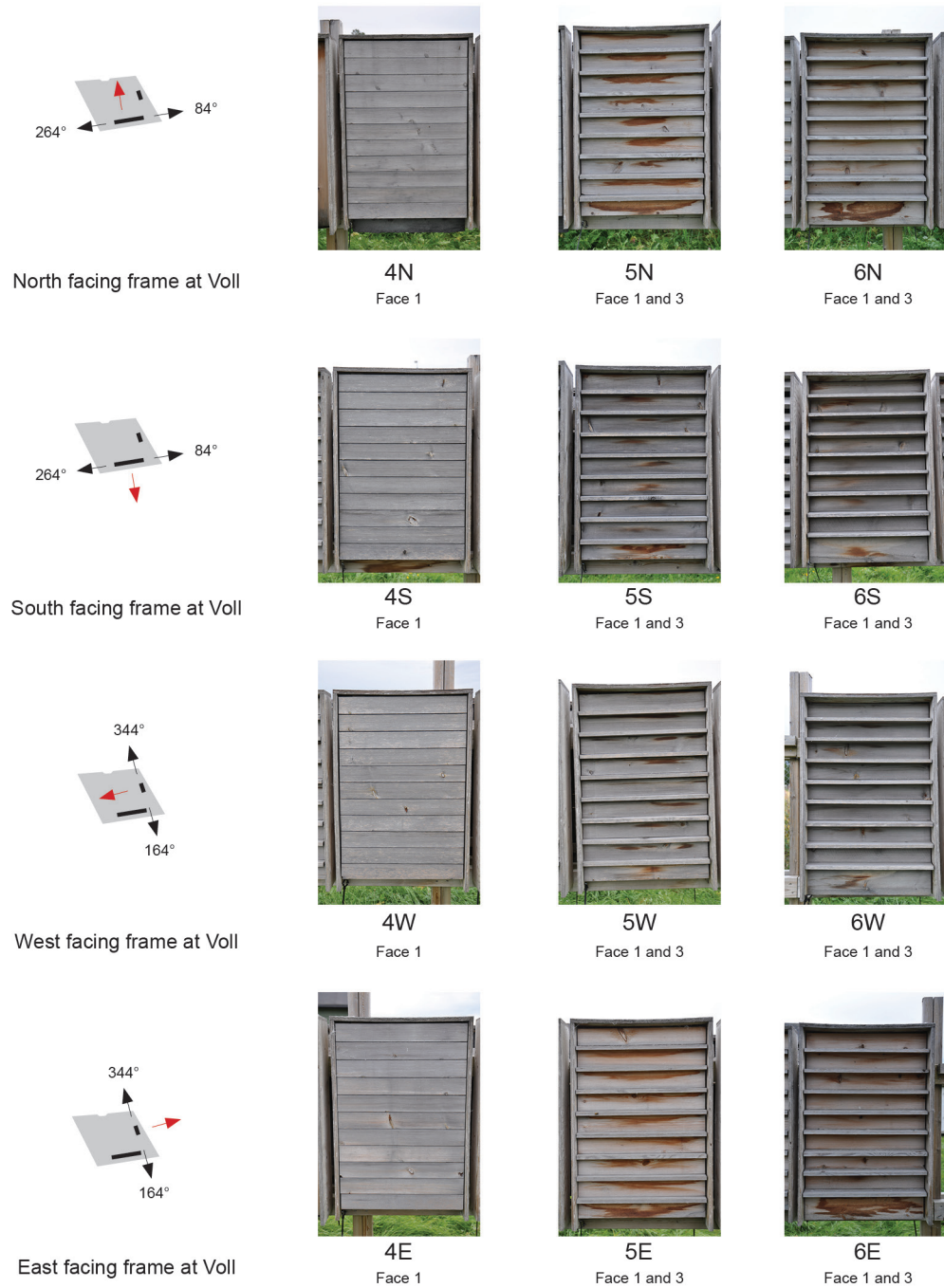

Figure 4.60 Continued from previous page. Claddings 4, 5, 6 and 8. Color development after exposure to weather at the Voll research fields from February 11th 2006 to September 11th 2010. Photo © Majbrit Hirche.



8N
Face 1



8S
Face 1



8W
Face 1



8E
Face 1

4.13 Evaluation of the experimental procedures

Methods for the experimental procedures were developed specifically for this work and used here for the first time, and hence a great deal of experience was gained throughout the cause of the study. For the sake of future reproduction of this kind of experimental setup, the following notes were made on ideas for improvement of the procedures.

End grain protection

Protecting the end grain areas of the claddings was considered important and the solution for doing so was to insert the cladding into a plywood protective frame. This solution seems to be workable, however details in the construction need to be improved.

The plywood roofs bended downward towards the weather side of some of the claddings, which directed water from the roof onto the claddings. This resulted in deviations from the pattern repeat. This was particularly visible on 2N and 3N. A solution to this problem could be constructing the roof with a backward slope allowing for water to run off behind the claddings.

The protective frames seem to have influenced the color development of particularly the left and right hand sides of the horizontal claddings, possibly due to reflections from raindrop splash from the vertical sides of the plywood frame. A solution to this problem could be making the samples larger. This would create a larger area at the central part of the horizontal claddings that was unaffected by this edge effect.

The protective frame was produced in 150 and 200mm depths due to varying depths of the claddings. This doesn't seem to have influenced the color development however, a single size frame would probably have been preferential.

Distance to the ground

In this experiment all samples were mounted on the supporting frames at a minimum height of 60cm above ground in order to minimize the effect of exposure to water splash and snow drift on the lowermost parts of the claddings. One might consider lowering the samples in future experimentation to more closely simulate real life situations in which the lower parts of a cladding are typically situated close to the ground. In a typical situation, the lower parts of particularly vertical claddings would most likely develop end grain grey coloring due to capillary action.

The size of the samples

The claddings in this experiment measured 600x900mm² including the plywood protective frame. One might consider increasing the size of the samples. Larger size samples would facilitate weathering on a larger area, thus minimizing the proportional size of the edge effects from a protective frame, provided that one is used. Larger size samples may also be preferable if the samples are mounted at a lower distance to the ground, as discussed above.

Scanning procedures

Scanning of the weathered surfaces proved a very interesting method for documentation of the colors. In order to optimize the procedures, following time-saving improvements are recommended:

The cladding should be constructed in a way that allows for fast and easy disassembly and reassembly of the boards. In this project ordinary screws were used. Unscrewing the fasteners was time-consuming, since the screws had fastened tightly into the wood. Likewise, reassembling the claddings after scanning took a long time.

The scanning should be performed using equipment with the size of the total length of the boards. In this project an A3 size flatbed scanner was used. Every board needed to be handled twice in order to capture the entire surface area. The scanning process, as well as the post-processing of merging the two halves of a board into a single image, was very time consuming. In addition, the merging of the scanned images had undesired esthetic consequences, particularly on the vertical claddings where the middle part of the surface was omitted.

One might consider scanning all surfaces prior to weather exposure. Photo-documentation of the initial color would serve as a good baseline reference for effectively communicating the progression in the color development. In addition, documentation of the starting point could be useful for some aspects of the subsequent analysis of the color development. For instance, it might prove invaluable in helping confirm whether a crack in the wood was present from the beginning of the experiment or developed at a later stage, as discussed in Section 4.3 regarding the surfaces of 3N2E, 3N10E, 3N4W and 3N10W.

4.14 Evaluation of the weather maps

The directional, spherical and surface weather maps developed for this study is designed to visualize the main weather factors responsible for weathering of untreated wooden surfaces, i.e. rain and solar radiation. The information provided by the maps is used to understand the relationship between local weather conditions at the Voll research fields and the weathering colors and color patterns that develops on the wooden claddings in this experiment.

The directional weather map provides an overview of the distribution of WDR, UV and sun hours from a 360° sector at Voll. With this information, the main characteristics of weather in the total sector is easily understood and related to the Voll site plan, as well as to the direction of the samples and that of the individual surfaces. The method of using horizontal sections of the claddings showing the angle openings towards weather, in combination with the display of the specific areas of the weather maps that corresponds to the angle openings, is a useful method for specifying the weather elements relevant for the analysis of the individual surfaces.

The spherical weather map provides a visualization of WDR as it is distributed in the sky above the Voll research fields. With this information, it is possible to point out

the main tendencies in the distribution of WDR in terms of both azimuth and height angles.

The spherical weather map provides useful information, particularly in the analysis of the horizontal relief claddings where the height angle of the precipitation is critical to the exposure of the shaded surface areas.

The surface weather maps provide an image of the distribution of WDR, UV and sun hours on the individual surfaces of the claddings. With this information, it is possible to compare the actual weathering colors of the individual surfaces of the claddings to a modeled image of the exposure conditions. The surface weather maps provide interesting suggestions for the understanding of the relationship between weather exposure and cladding design.

The surface weather maps only provide information on the weather exposure conditions. Understanding the wood surface reactions to the weather exposure requires knowledge of the biological and chemical weathering processes.

The WDR surface weather maps provide information on the direct WDR exposure. Exposure from indirect weather such as raindrop splash is not included in the visualizations. However, the results suggested that color development due to indirect WDR exposure played a part in understanding the actual full color development of the surfaces.

Despite the simple methods used for calculating WDR, UV and sun hours, the maps provide convincing information on the weather conditions at the Voll research fields that is in agreement with the weathering color development of the claddings in this experiment.

5 Discussion

The experimental setup in this work was designed to lend better understanding to how untreated wooden claddings with different geometries develop weathering colors when exposed to different weather conditions. No prior investigation of this kind has been reported hence little research based information is available for comparison to the results obtained in this work.

It has been customary to use case studies as the primary source of information about weathering colors of wooden cladding and consequently conventional guidelines for the building sector are mainly based on experience derived from built works. However, some of the results obtained in this work clearly bring into question the veracity of key aspects of conventional knowledge in the field. The principal areas of discussion concerns the use of

- Compass direction as a guideline for predicting color development of wooden cladding
- The cladding geometry as a guideline for predicting weathering colors and color pattern

In the following, conventional knowledge and guidelines are discussed in relation to the results obtained from this experiment.

5.1 Compass direction as a guideline for predicting color development of wooden cladding

North facing wooden façades are commonly associated with fast mono color grey weathering (Larsen, K.E. and Mattsson, J. 2009). However, the weathering that occurred under the prevailing weather conditions at the Voll research fields did not comply with this rule of thumb. The fastest and most uniform grey color development occurred towards the main WDR direction i.e. west and south-west, as shown in the directional weather map.

South-facing wooden surfaces are associated with brown color development after a period of grey color in the initial phases of weathering (Larsen, K.E. and Mattsson, J. 2009). The south-facing surfaces in this experiment developed grey. It seems unlikely that the south-facing surfaces, weathered under the prevailing weather conditions at

Voll, will, with time, turn brown. The south-facing surfaces are exposed to WDR as demonstrated in the directional weather map and repeated exposure to moisture is likely to favor the continuous growth of dark walled fungi, thus keeping these surfaces grey colored.

In this experiment, the south-facing instances closest to complying with a brown color development are the brown colored 2S+3S Face 4 and 2E+3E Face 2. These samples were mounted at the south- and east- facing supporting frames respectively. The brown colored surfaces of these samples were facing east and south respectively as demonstrated in the directional weather maps Figs. 4.14 and 4.22. The brown color of these surfaces weathered under conditions characterized by low amounts of WDR in combination with high amounts of UV and sun hours, which kept the growth conditions for colonization of dark walled fungi at a minimum apart from the lower ends of the boards. Exposure to this combination of weather is known to cause brown color development on south facing surfaces in high altitude regions. The UV-intensity increases with the altitude. This experiment was carried out at an altitude of 127m A.S.L., and hence the weather conditions under which these surfaces developed brown cannot readily be compared to conditions in high altitude locations. It appears that the brown color of these surfaces is primarily the result of extractive deposits rather than UV-exposure and the accumulation of lignin degradation products on the surfaces.

It is questionable to what extent the use of compass directions is a valid point of reference for predicting color development of wooden surfaces and cladding. The fast and uniform grey color development associated with north-facing surfaces may in some instances apply, whereas in other instances orientation towards the main WDR direction is the dominant factor in the grey color development. The brown color development associated with the south-facing surfaces is equally uncertain. In high altitude regions, where low amounts of WDR in combination with increased levels of UV radiation are found, the brown colored south-facing wooden surfaces are often seen. Due to the decrease in the UV-intensity from high to low altitude locations, a general rule of thumb that associates brown color to the south-facing direction should be used only when it is certain that the wooden surfaces are to weather in high altitude locations.

Another problem associated with using compass directions as a guideline for weathering color development is that the geometry factor of the wooden cladding is left out. The weathering colors and color patterns are created through the interaction of geometry and weather, as demonstrated in this work. It is the specific location in the context of the specific cladding geometry in combination with the specific exposure conditions of the individual surfaces that determine the color development. The use of compass direction as a guideline for color development is far too open-meshed for any realistic evaluation of the color development of wooden claddings.

A final remark on the use of compass directions concerns the problem that current guidelines only assess the cardinal compass directions: north and south. Building envelopes may face several directions, hence guidelines that consider only two directions are inadequate for evaluating the potential exposure conditions of the total building envelope.

Weathering of wooden claddings is a context-dependent phenomenon. The principal factors to include in an evaluation of the color options of a wooden cladding are the geometry and the actual exposure options.

Any general statement that relates compass direction to color development of a wooden surface is uncertain and the risk of misguiding the end users is high. In this work, methods for modeling and visualization of the in-situ weather i.e. WDR, UV and sun hours, were developed. These tools provide far more detailed information on the weather factors that must be taken into consideration when assessing color options for untreated wooden claddings than the current use of compass directions. In order to establish a realistic relationship between compass direction, exposure- and color options of any given wooden cladding, it is essential to know the specific in-situ weather conditions at the building site. Without accurate knowledge of the actual weather conditions at a site, any prediction of weathering colors and color pattern of wooden claddings is guesswork.

5.2 The cladding geometry as a guideline for predicting weathering colors of wooden cladding

Conventional knowledge of color development of different types of cladding geometries associate the plane type of cladding geometries with uniform mono color grey weathering, and relief types of claddings with multi-color weathering (SINTEF Byggforsk 2008). The latter involves extractive deposits however, this aspect of weathering is not further specified in current literature on weathering of wooden cladding. The results in this work demonstrate that the plane type of cladding displays the mono color grey option whereas the relief types display both mono and multi-color options. The mono color grey option for the relief type of cladding occurred on Cladding 2 Samples 2W and also at a later phase on the deeper relief Cladding 3 Sample 3W. In addition, 8W was close to mono color grey except for a minor brown streak on the upper edges.

Accurate prediction of colors based on the geometry seems possible with plane types of cladding. Plane types of cladding geometries are much simpler compared to the relief types since there is only one surface type and no shading elements to interact with the weather exposure. The rate of grey color development of the plane types may vary, as clearly demonstrated in this work. The mono color brown option did not occur on the plane type of claddings in this experiment. This color option is typical for high altitude regions and it remains an open question whether this color option is also available to plane cladding types located in the lowlands of temperate zones.

Predicting the color development of relief types of claddings requires knowledge of the color potentials of the specific type of geometry. As demonstrated in this work, one cladding type may have several color pattern options. Which color pattern ultimately develops depends on the actual exposure. The phenomenon of several color pattern options for identical types of claddings was particularly clear on Cladding type 2 and 3 in this work. Only when the color potentials for a specific type of cladding is studied and documented is it possible to realistically assess and evaluate the color options for

the cladding in question in relation to the exposure conditions available at a given building site.

The claddings in this work were made of primarily heartwood of Scots Pine (*Pinus Sylvestris L.*). The presence of sapwood in the claddings was not intended. Conclusions regarding color options related to a specific type of cladding are based on the results obtained from this experiment, hence limited to one type of wood species, tissue and surface character only. However, as demonstrated in the framework for design options Fig. 3.12, a number of variables can be applied to the design which most likely would add more color options to a cladding.

An idea that emerged during the analysis of the results was to deliberately use sapwood to help facilitate grey color development on areas of a cladding that are less likely to develop grey, for instance due to dry surface conditions caused by shade. One proposed additional experiment would be to replace Face 1 of Cladding 5+6 with boards containing mixed sapwood and heartwood. Mounting the boards with the sapwood part up at the dry area and the heartwood part on the WDR-exposed area could perhaps lead to grey color development on areas that would otherwise develop extractive deposits. This design variable could result in a mono color grey of Face 1 of this type of cladding, thus adding another color pattern option to the already documented weathering color patterns of this cladding type. Likewise the use of unplanned surfaces could add interesting nuances to a color pattern. These examples are but some thoughts on creative ways to deliberately use the potentials of wood to create interestingly weathered claddings.

Relying on the compass direction and/or the geometry of a cladding for the prediction of weathering colors and color patterns of a wooden cladding is highly uncertain. The optimal basis for assessing the color potentials of a wooden cladding is knowledge of the in-situ weather conditions. One way of obtaining information about the in-situ weather is by means of weather maps generated from local weather data, as illustrated in this work. With information on the in-situ weather conditions, it is possible to assess the specific weather at the building site and to evaluate possible exposure- and weathering color options of a wooden cladding and façade.

6 Suggestions for future research

The results obtained in this work point to a number of interesting options for further development of this field of research in ways that address not just the architectural profession but also the general public, for whom the use of untreated wood in outdoor applications may be of interest.

Suggestions for future research focuses on three principal areas:

1. Further experimental research
2. Further development of weather diagrams
3. Publications on wood weathering

Further experimental research

Investigating weathering colors of wooden claddings by means of experimental methods that resemble conditions in a building context seems like a very good strategy. It allows for the best possible use of information obtained from an experimental environment to address problems that arise in real life situations.

The options for designing a cladding are numerous as discussed in Chapter 3. All options represent design variables for the construction of a wooden cladding and therefore also design variables regarding weathering. The framework shown in Fig. 3.12 may serve as inspiration for future research on specific elements present in a wooden cladding.

Of particular interest for further experimental investigation is to understand more about

- Weathering of wood species grown in the Nordic region. A growing number of consumers assess and choose wood material based on environmental, political and ethical considerations. Very often overseas wood is used as façade material due to powerful marketing of these products and lack of locally produced alternatives. It would be of high interest to investigate material grown in the near regions from the perspectives of weathering as well as durability in the above ground environment.

- Weathering of wood with different surface characteristics. Although only a limited number of unplanned surfaces were present in this work, it seems that weathering of unplanned surfaces differs from that of planned surfaces in ways that are potentially very interesting for designing with color variations of the wooden surfaces.
- Mono color grey weathering, and in particular silver grey weathering, are often appreciated and requested by the consumer. It would be of high interest to further investigate options for obtaining specific weathered appearances of wooden cladding and to communicate this information to the consumers. Pre-weathered material could be one interesting research activity within this area, as well as investigating options for implementing and controlling surface fungal growth on areas that are less likely to be exposed to weather conditions that facilitate biological weathering.
- In-situ weather conditions play a vital role in the way that untreated wooden cladding develops its unique color pattern, as was clearly demonstrated in this work. It would be of interest to investigate weathering of untreated wooden cladding under different weather conditions such as those prevalent in urban, woodland, coastal and mountainous locations.
- The presence of extractive deposits as part of the weathering color pattern of a wooden cladding is often regarded as a negative consequence of weathering. However, this wood weathering color option has interesting perspectives. It would be of interest to develop a series of claddings that make deliberate use of extractives as part of the color design and to communicate this fascinating and unique weathering color option to the consumer.
- Sapwood is an interesting type of wood tissue due to its ability to quickly facilitate colonization of dark walled fungi. Sapwood is also a high quality substrate for wood decaying fungi and always recommended against due to the risk of rotting when it is exposed to water. However, if used with care, sapwood could perhaps replace heartwood in locations that are exposed to only very small amounts of water. This would facilitate grey color development in these locations. It would be interesting to carry out experiments where sapwood is studied from the perspective of weathering in a predominantly dry outdoor environment.
- Wood is available in a large variety of tissue types. Differences in density, toxicity, porosity, cell type and -organization, as well as the chemical composition of the cell wall matrix and the extractives are all variables that come into play in the processes of weathering. It would be of interest to carry out experiments on a variety of tissue types to understand more about the details of weathering with regard to color nuances and surface materiality. More understanding of the details of the weathering of different types of wood tissue would further enlarge the register of refined wood weathering design options.

- Claddings may be grouped into typologies according to the geometric features. In this work, two types were defined: plane and relief types. Relief types can be further sub-grouped and the surface shade characteristics of the types described by means of diffuse light simulations, as was demonstrated in this work. The cladding types can be tested experimentally, in a manner similar to what was done in this work, and the weathering color options related to the specific cladding type documented and analyzed. A study like this could form the basis for a catalogue of basic cladding types and their related color pattern options under different weather conditions. The catalogue could be expanded as more knowledge is accumulated on details in color variations between tissue types, surface character and other factors of interest.
- Weathering is a process that develops over time. The time factor is included in the weathering equation: wood + design + weather + time = weathering. However in this work, the time factor was only discussed to a limited extent. Knowledge of the visual appearance of a wooden cladding as the process develops is of interest to further understand and document. This knowledge can be used to inform and prepare the client for the different stages of weathering and the related visual appearance of the cladding, thus creating realistic expectations of the color development in all stages of weathering.
- The color description of the weathered wood turned out to be a challenging task as discussed in Section 4.1.1. It would be of interest to further study this particular aspect of wood weathering in order to communicate effectively the broad range of color nuances of weathered wood surfaces.

Further development of weather diagrams

The three types of diagrams proved very useful for understanding the relationship between the in-situ weather at the Voll research fields and the weathering colors of the claddings in the experiment. But the diagrams have wide-ranging perspectives for use in the architectural profession, as well as to consumers in general.

The directional weather map, complemented by the WDR spherical map, can be used to gain a fast overview of the dominant weather conditions at a given site. The directional weather map can supplement site plans, terrain- and plantation maps and other materials that provide the architect with information about the building site. The information provided by this type of map can be used as inspiration for designing architecture that is specifically adapted to the in-situ weather conditions in an effort to achieve a predictable outcome. For instance, information on the directional distribution of WDR can be implemented in the overall design scheme for the building and its relation to the location, as well as the choice of materials and detailing according to the main exposure conditions at the site.

Surface weather maps can be used to simulate the distribution of WDR, UV and sun

hours on the surfaces, as demonstrated in this work. The weather exposure can be simulated at any given time in the design process and provide the architect with useful information about what to expect in terms of surface weather exposure. The design can be evaluated and modified according to the simulated weather exposure and the intentions of the architectural ideas, for instance in relation to the design of construction details and the choice of materials.

In the design of wooden envelopes, and in particular when untreated wood is used, the possibility of simulating weather has very interesting perspectives. Information on weather and in particular WDR on the wood surface area can be used as a guideline for choosing wood quality. With reference to the results obtained in this work, the weather conditions simulated for the west and east facing surfaces represented wet and dry surface weather conditions respectively. This kind of information, should it be readily available in the design process, can open up very interesting design options. For instance, wood species and qualities that today are recommended against may actually be used on areas of the envelope where dry surface conditions are to be expected. A more detailed knowledge of weather exposure conditions allows for a much more differentiated approach to the use of wood material than is currently practiced. At best, realistic expectations of what surface weather, and hence what coloring results to expect, could inspire creative exploration of the limitless options available for designing with wood as façade material.

Of particular interest for further research activities related to the weather diagrams are:

- Validate the applicability of the three types of weather diagrams. One research activity would be to carry out experimental as well as field studies, where weathered wooden claddings are compared to the information in weather diagrams based on data from nearby weather stations. In order to understand more about the possibilities and limitations of the surface weather maps, it would be of interest to compare a WDR exposure pattern as calculated by Computational Fluid Dynamics modeling (CFD) to the WDR exposure pattern as calculated by the surface weather maps.
- Develop software that can translate information on WDR and solar radiation to weathering colors of the modeled wood surfaces and claddings. Renderings that illustrate the weathering color and color pattern would be a very useful tool, used to create realistic images of the color potentials of a given surface and cladding.
- Put up for debate present day standards for recommendations for the use of untreated wood in above ground outdoor applications with regard to durability. Although this work focuses on wood weathering, it also provides knowledge on aspects of in-situ weather with particular regard to WDR that can be applied to the field of durability of untreated wood.

- The diffuse light simulations developed for this project and discussed in Section 3.1.4 allows for the study of shade pattern created by the geometry of a cladding. It would be of interest to further develop the method of diffuse light simulations for studies on how different types of surface shade and shade patterns relate to different types of color development.

Publications on wood weathering

Publications available on weathering of untreated wooden claddings can roughly be grouped into four categories: scientific articles, building guidelines typically published by building research institutes, architectural publications and commercial sales promotional material.

Scientific articles on wood weathering typically have little relevance in practical architectural design. Understanding the content requires an expert's knowledge. The language is highly technical and the topics concern narrow aspects of wood and wood weathering.

Building guidelines typically combine science based knowledge with experience from built works. Publications address the general public and the information relates to actual problems in building contexts. Unfortunately, more often than not, the authors advocate for certain types of outcome of the weathering processes. The concealed esthetical agenda is promoted through biased language and stressed with photos that favor one type of color development and discourage others. It is a problematic mixture of personal preferences and scientific publishing that inevitably influences consumers' choices.

Architectural publications on wood architecture predominantly focus on the architecture and not specifically on the weathering aspects of the façade and the cladding. New constructions are published as soon as the work is finished and off course at this stage of development the wooden cladding always appears in the mono color of the fresh wood. Aspects of weathering of untreated wooden claddings are rarely mentioned.

Commercial sales promotional material typically claims that information is based on scientific knowledge, and may even be recommended by experts. Commercial promotional material, by its very nature to support the sale of a particular product must be regarded as highly biased.

In the opinion of the author, publications on weathering that target the end user, must combine solid science based knowledge with objective information that can inspire and encourage the reader to further pursue constructing with untreated wood in outdoor applications.

This would include publications that:

- Describe the multiplicity of options for creating interestingly weathered wooden claddings and façades, and provide guidelines on how to achieve a particular weathered look of the cladding and the façade.

CHAPTER 6: SUGGESTIONS FOR FUTURE RESEARCH

- Describe the natural wood weathering processes in a way that combines the technical aspects of weathering with visually inspirational photos that demonstrate the multitude of options with regard to color and materiality of the weathered wooden surface. The author would like to specifically recognize the beautifully designed work on wood anatomy by Rudi Wagenführ (Wagenführ, R. 1999) as a source of inspiration.

The suggestions presented here for future activities in this particular branch of wood weathering research represent but a limited selection of ideas on how to develop the field. The suggestions all relate to practical use in building design. As stressed throughout this work, the options for combining wood, design and weather to create interestingly weathered wooden claddings and façades are infinite. Equally infinite are the options for research activities that can produce new knowledge which one can hope will inspire and encourage the use of untreated wood as façade material.

7 References

- Brandstätter, M. et al. (2002) *Holzfassaden: Rohstoff Material Befestigung Detail System Oberfläche*. Wien: Forschungsinstitut und akkreditierte Prüf- und Überwachungsstelle der Österreichischen Gessellschaft für Holzforschung (Holzforschung Austria).
- Eaton, R.A. and Hale, M.D.C. (1993) *Wood: Decay, Pests and Protection*. London: Chapman & Hall. Ch.
- Feist, W.C. and Hon, D.N.-S. (1984) *Chemistry of Weathering and Protection*. In: Rowell, R.M. (ed.) *The Chemistry of Solid Wood*. Washington D.C.: American Chemical Society.
- Geving, S., Erichsen, T.H., Nore, K. and Time, B. (2006) *Hygrothermal conditions in wooden claddings – Test house measurements*. Report from the R&D -programme “Climate 2000”. Project report 407-2006. Trondheim: Norwegian Building Research Institute.
- Gobakken, L.R., Mattsson, J. and Alfredsen, G. (2008) *In-Service Performance of Wood depends upon the Critical in-situ Conditions. Case Studies*. The International Research Group on Wood Protection. 39th Annual Meeting 2008, Istanbul, Turkey. Available at: http://www.skogoglandskap.no/filearchive/irg_08-20382.pdf (29.3.2014)
- Kirk, T.K. and Cowling, E.B. (1984) *Biological Decomposition of Solid Wood*. In: Rowell, R.M. (ed.) *The Chemistry of Solid Wood*. Washington D.C.: American Chemical Society.
- Kollmann, F.F.P. and Côté, W.A. jr. (1968) *Principles of Wood Science and Technology*. Berlin - Heidelberg: Springer Verlag.
- Larsen, K.E. and Mattsson, J. (2009) *Ubehandlede trefacader*. FOKUS på tre nr. 30. Norsk Treteknisk Institutt.
- Rieder, Max (2008) Private communication: email dated 31.5.2008 from Max Rieder to Majbrit Hirche regarding details in the design of Aigen Kindergarten.
- Rüther, P. (2011) *Wood Weathering from a Service Life Perspective*. Ph.D. thesis, NTNU, Norway.
- SINTEF Byggforsk (2008) *Kledninger av ubehandlet tre*. Byggforskserien nr. 542.645.
- Wagenführ, R. (1999) *Anatomie des Holzes*. Leinfelden – Echterdingen: Weinbrenner-GmbH & Co.

CHAPTER 7: REFERENCES

- Williams, R.S. (2005) *Weathering of Wood*. In: Rowell, R.M. (ed.) *Handbook of Wood Chemistry and Wood Composites*. Boca Raton: CRC Press.
- Zabel, R.A. and Morrell, J.J. (1992) *Wood Microbiology: Decay and its Prevention*. San Diego: Academic Press, Inc.

APPENDIX A. FROTTAGES OF SAMPLE 1N, 1S, 1W AND 1E

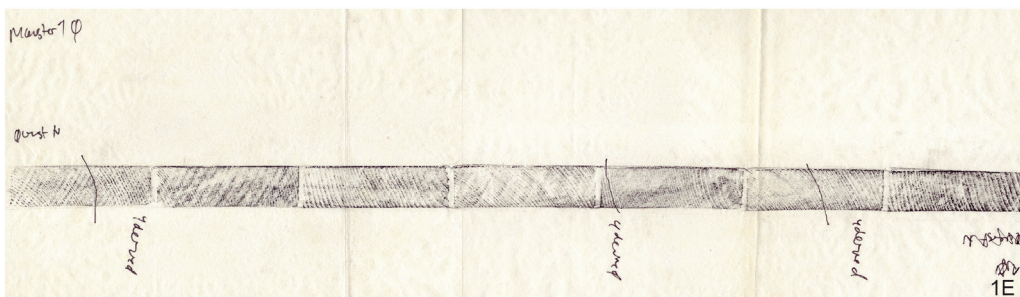
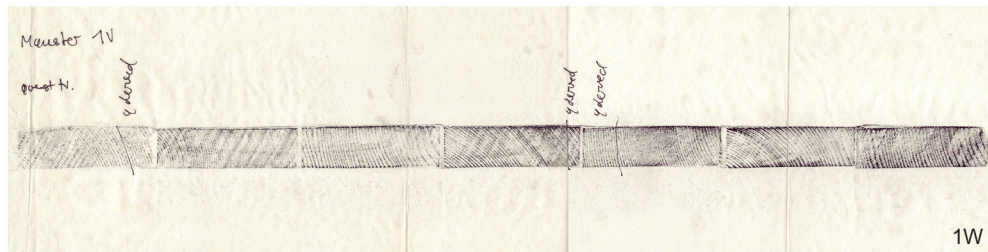
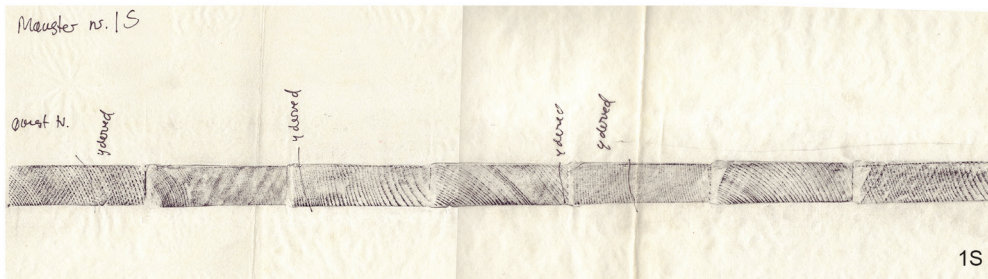
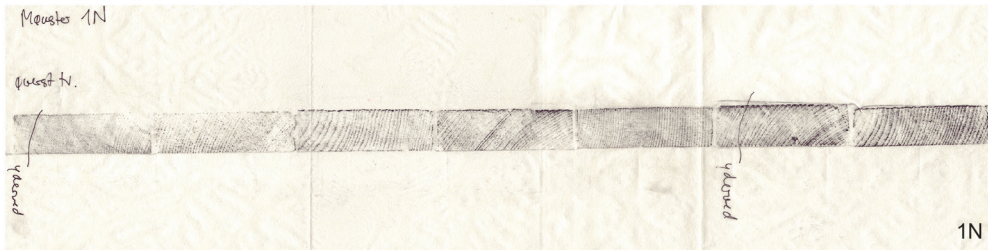

APPENDIX A. FROTTAGES OF SAMPLE 2N, 2S, 2W AND 2E

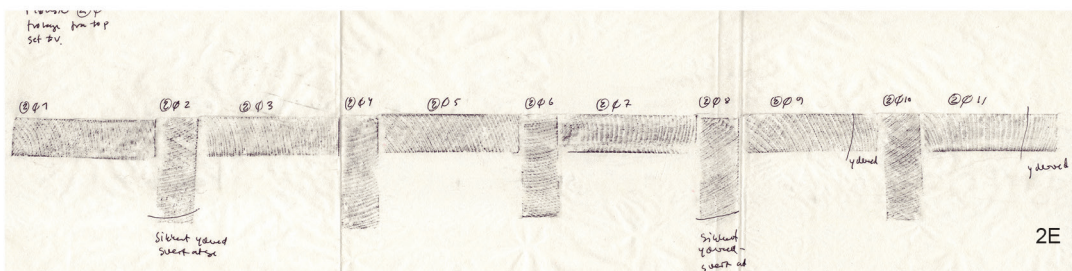
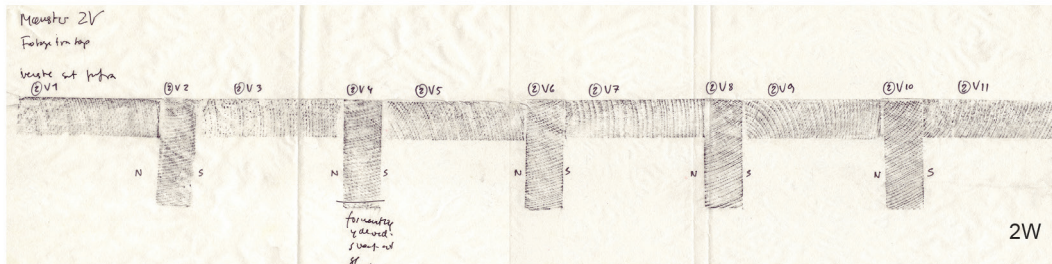
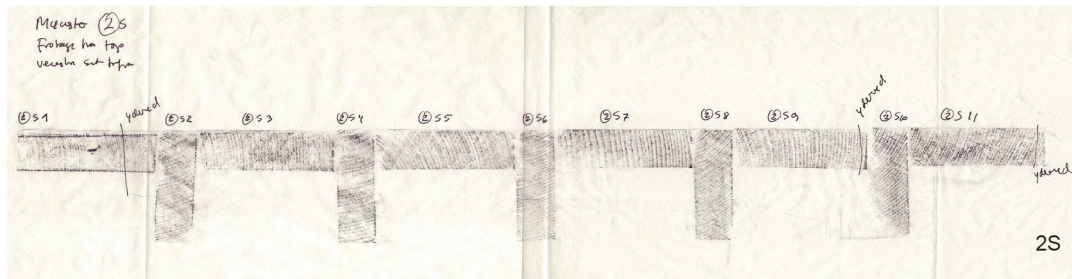
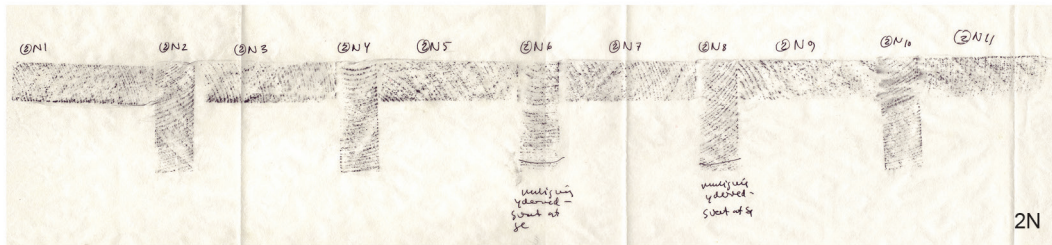

APPENDIX A. FROTTAGES OF SAMPLE 3N, 3S, 3W AND 3E

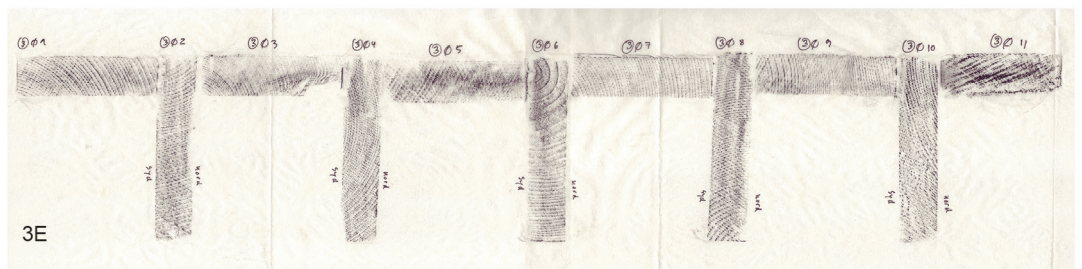
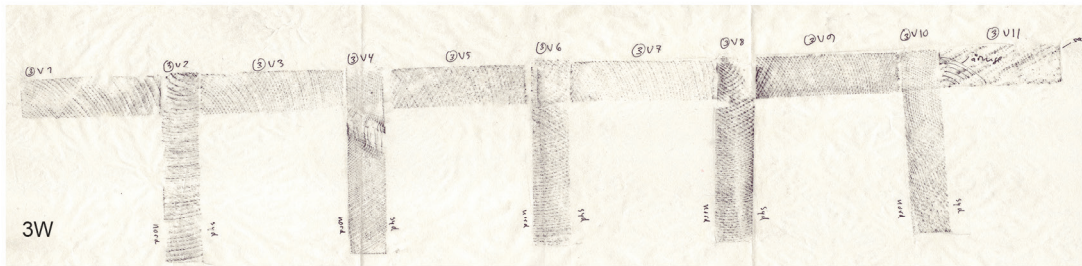
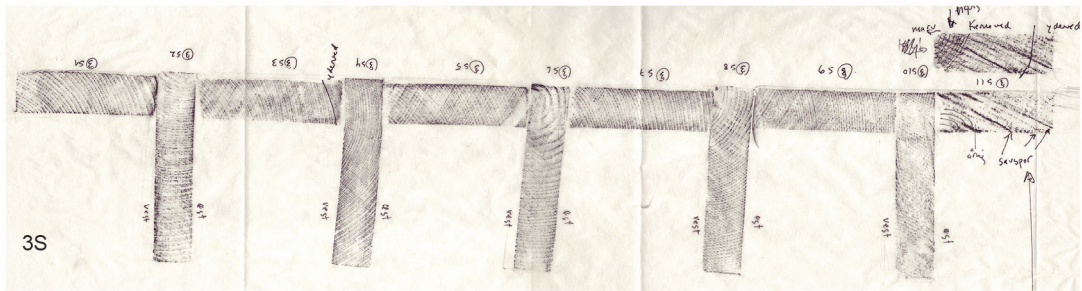
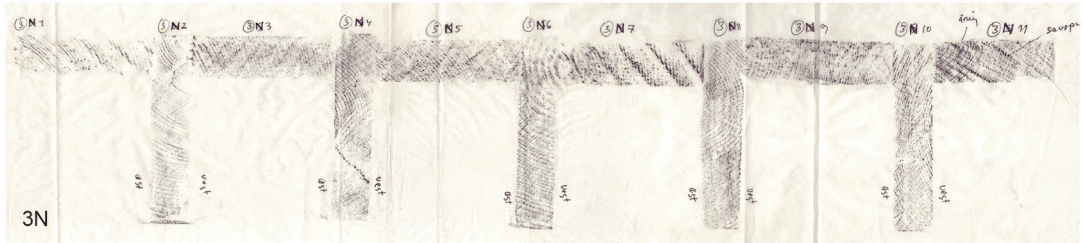

APPENDIX A. FROTTAGES OF SAMPLE 4N, 4S, 4W AND 4E



APPENDIX A. FROTTAGES OF SAMPLE 5N, 5S, 5W AND 5E

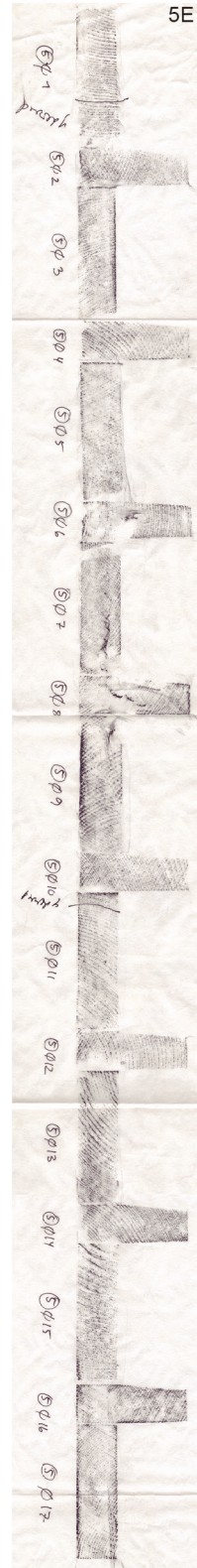
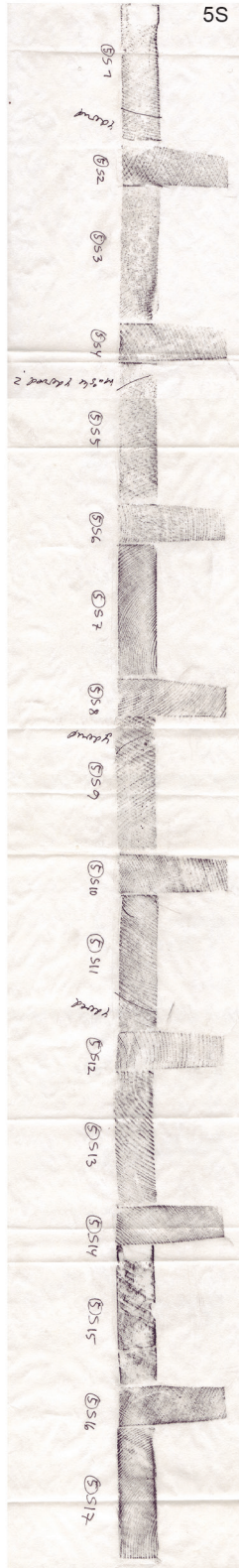
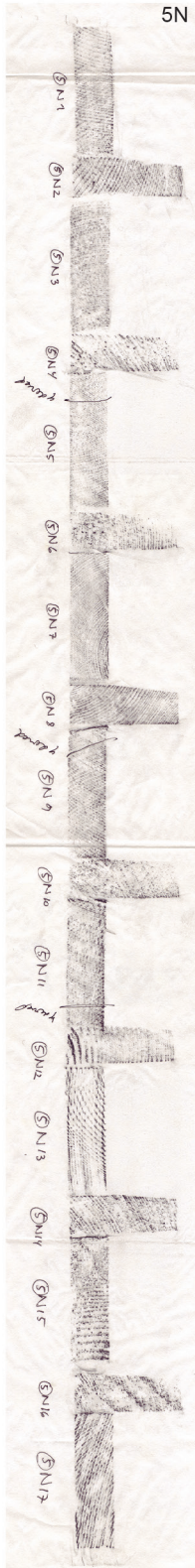

APPENDIX A. FROTTAGES OF SAMPLE 6N, 6S, 6W AND 6E

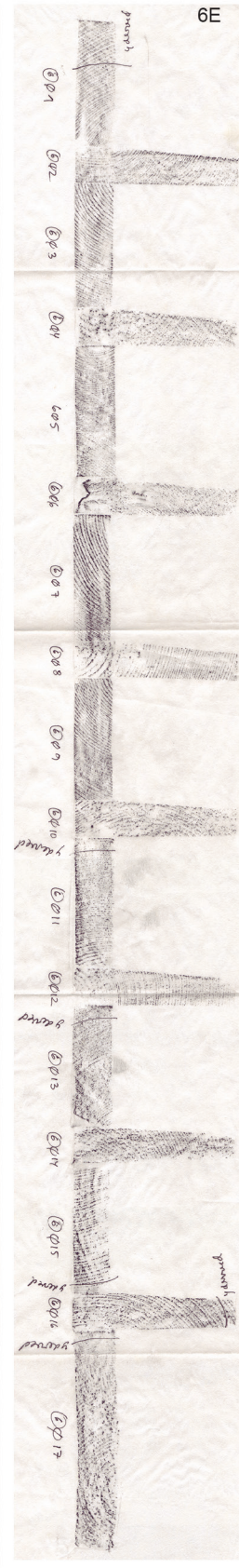
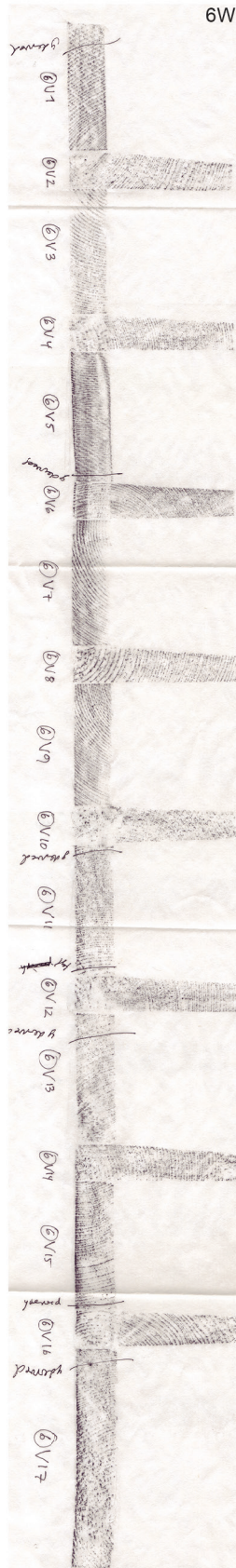
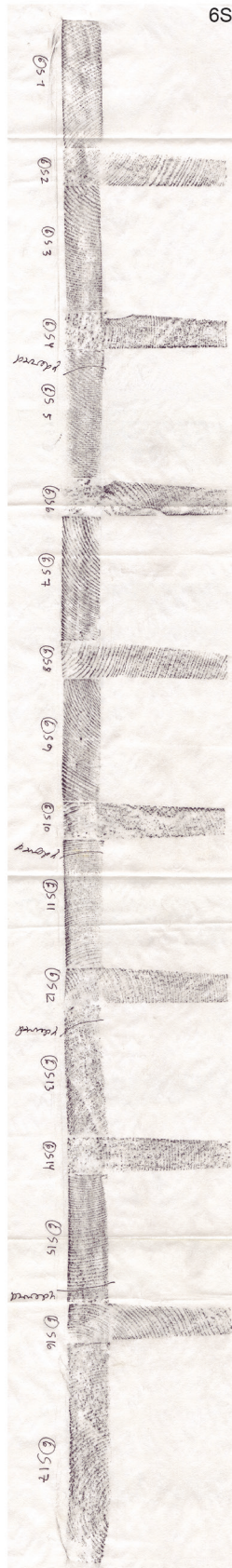
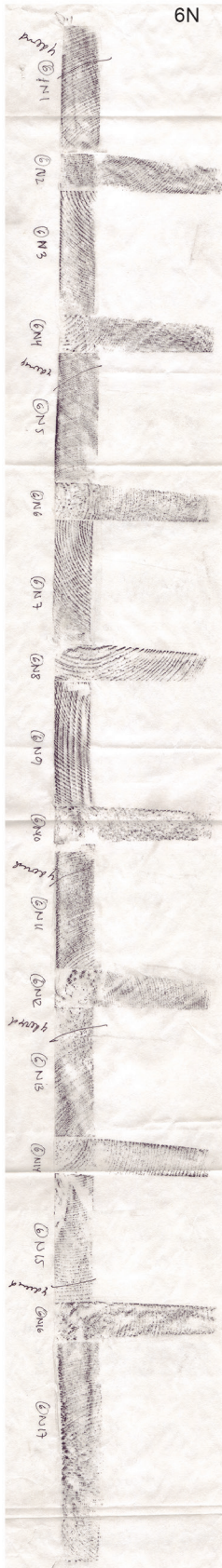

APPENDIX B. DRAWINGS OF THE CLADDINGS IN THE EXPERIMENT

Claddings mounted in a 150mm deep plywood protective frame

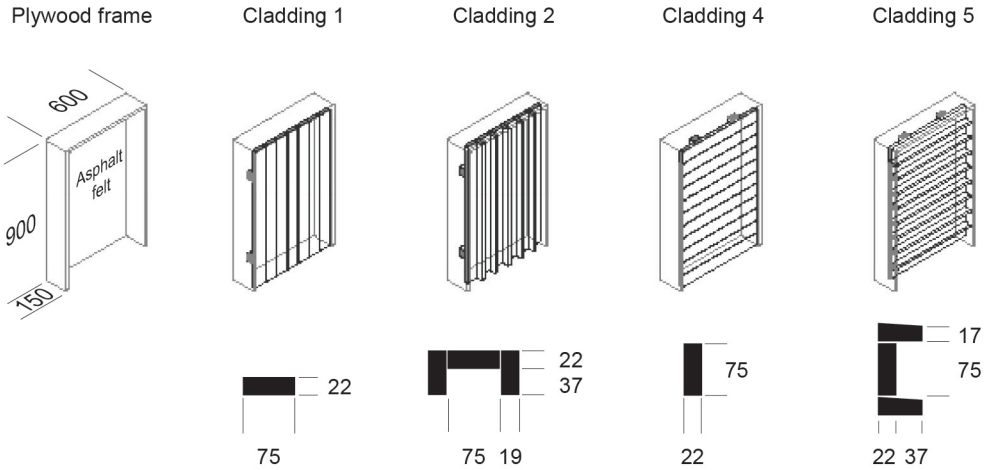

Claddings mounted in a 200mm deep plywood protective frame

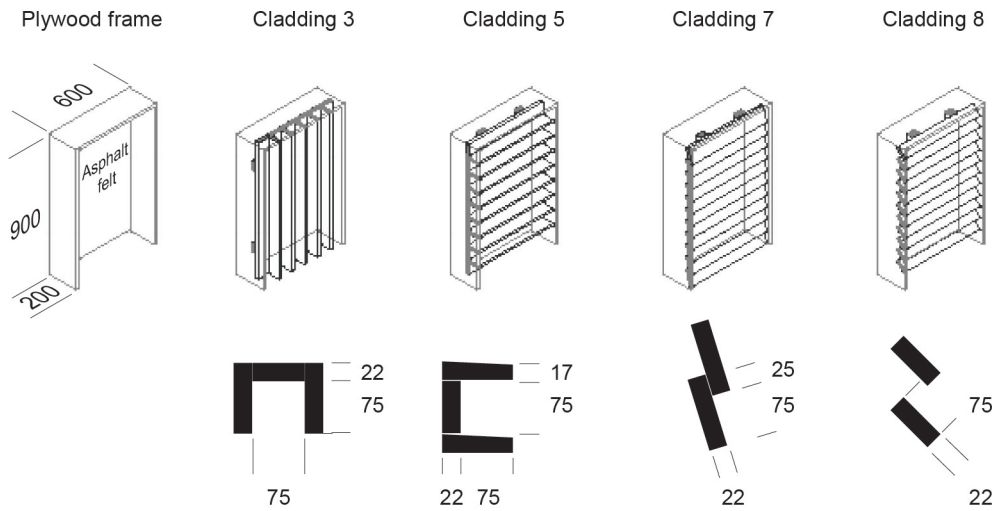

All measures are derived from a standard size unadjusted board of Scots Pine measuring 1"x3" or 25x75mm. Upon planing the surface is cut 3mm. The protective frames are made of 18mm plywood boards from spruce. All measures are in mm.

Weather Maps

Steen Aagaard Sørensen

May 2, 2014

Abstract

This minute summarizes the methods and models applied in the construction of weather maps and surface weather exposure visualizations.

1 Data and Model Basis

The data basis for all diagrams is a set of weather time series data obtained in the period 1999 - 2006 from an automatic weather station (type "Vaisala") placed at the experimental site. With the identification number 68860 (WMO 01257), the applied station is part of the weather station network operated by the Norwegian Institute of Meteorology (MET Norway).

The following elements are used :

- *RR*: Accumulated amount of precipitation in the data point observation period (*i.c.* one hour) in units of mm (equivalent to liter/m²). The amount of precipitation is determined by weighing. This implies that precipitation in other forms than liquid water (*e.g.* snow or hail) is accounted for as the amount of water after melting. Occasionally, the element is denoted *RR.1* to emphasize the collection period of one hour.
- *RT*: Number of minutes with precipitation during the period of collection.
- *DM*: Average wind direction during the data point observation period (*i.c.* one hour) measured 10 meters above terrain. The average direction is reported in degrees measured clock-wise from true North.
- *FM*: Average wind speed during the data point observation period (*i.c.* one hour) measured 10 meters above terrain. The average wind speed is reported in units of m/s.
- *TA*: Average air temperature during the data point observation period (*i.c.* one hour). Reported in degrees centigrades.

The time resolution of one hour is the highest resolution obtainable from accessible data archives. Due to irregularities in the operation of the precipitation and wind speed gauges during 2007 - 2009, the time series has been trimmed down to cover 1999 - 2006 only.

1.1 Wind Driven Rain

The amount of wind driven rain (WDR) (*i.e.* the amount of rain driven by wind onto a vertical surface) is estimated by the Lacy WDR expression¹:

$$RR_{WDR} \approx 0,222 \frac{FM}{\left(\frac{RR}{RT} 60 \text{min/h}\right)^{0,123}} RR \quad (1)$$

The expression estimates the amount of water, RR_{WDR} , collected on a vertical surface directly facing the wind direction (surface normal parallel to wind direction) in a data point observation period. RR denotes the amount of rain falling on a horizontal surface during RT minutes and with the wind speed FM . Lacy's expression is derived from the flux consideration:

$$RR_{WDR} = \frac{v_h}{v_v} RR$$

with v_h and v_v denoting the horizontal and vertical speed of rain drops, respectively. During the fall of a raindrop in the atmosphere, a steady-state will form with v_h equal to the local wind speed: If the horizontal speed of the drop exceeds the horizontal speed of the surrounding air mass, the drop will be slowed down by the air resistance. Conversely, if the horizontal speed of the drops is lower than the horizontal speed of the surrounding air, the drop will be accelerated by the air drag. Hence, v_h can be directly replaced by FM . The terminal value of the vertical speed of the drop depends upon the size of the drop as it is determined by a balance between gravity and buoyancy on one side and air resistance on the other. Lacy's WDR model uses the empirical values of the terminal vertical speed established by Gunn and Kinzer². With this basis, the ratio $\frac{v_h}{v_v}$ (known as the catch ratio) may be estimated for a given rain drop size. A rain shower consists of a continuous distribution of drop sizes depending on the intensity of the shower. From empirical studies, Best³ has established a relation between shower intensity expressed as mm rain falling on a horizontal surface per hour and the drop size distribution. For a

¹B. Blocken, J. Carmeliet: J. Wind Engineering and Industrial Aerodynamics, **92** (2004) 1079-1130

²R. Gunn, G. D. Kinzer: J. Meteorology, **6** (1949) 243-248

³A. C. Best: Quarterly J. Roy. Met. Soc. **76** (1950) 16-36

one-hour based observation point, the average shower intensity is estimated by then ratio:

$$\frac{RR}{RT} 60\text{min/h}$$

Now combining this with the Best size distribution and the terminal speed measurements of Gunn and Kinzer gives the average catch ratio estimate:

$$\left\langle \frac{v_h}{v_v} \right\rangle \approx 0,222 \left(\frac{RR}{RT} 60\text{min/h} \right)^{-0,123}$$

As mentioned, the Lacy expression (1) estimates the amount of WDR falling on a vertical surface facing the wind direction. If we have a fixed surface and a number of rain events with different wind directions, the total amount of WDR on the surface is calculated as the sum of contributions from the individual events weighted by cosine of the angle between wind direction and surface normal, *i.e.*:

$$RR_{WDR} \approx 0,222 \cdot \sum_i \frac{FM_i}{\left(\frac{RR_i}{RT_i} 60\text{min/h} \right)^{0,123}} RR_i \cos(DM_i - \theta) \quad (2)$$

with the sum including observations with wind direction in the interval $\pm 90^\circ$ around the surface normal direction, θ .

When dealing with WDR in the framework of the Lacy model, the following reservations are to be observed:

- The Lacy expression in the forms (1) and (2) estimates the amount of WDR assuming an unperturbed wind field. No attempts have been made to take into account the effects of buildings, vegetation, terrain or any other sources of wind field perturbation. The standard document ISO 15927-3 introduces a number of corrections for the Lacy expression: The *topography factor*, T , the *terrain factor*, R , the *obstruction factor*, O and the *wall factor*, W . These corrections represent crude average treatments of the various effects and they have not been considered relevant for the present treatment of weathering induced color changes. A more detailed treatment of the distribution of WDR on building surfaces involves a computational fluid dynamics (CFD) modeling of both the wind field and the motion of rain drops in this field. Such calculations have been done for a very limited set of archetype building geometries⁴ but the calculations are highly involved and require high quality data for wind and precipitation with a time resolution of at least 10 minutes. No attempts have been made to conduct CFD modeling in the present work.

⁴B. Blocken, J Carmeliet, J. Wind Engineering and Industrial Aerodynamics, **94** (2006) 101-127

- All precipitation events (*i.e.* observations with $RR > 0$) are treated as rain. When it comes to air dragging, snow behaves very differently from water, and one may consider excluding all observations with the average air temperature element, TA less than 2 centigrades.
- When using (2) to sum the WDR contributions from rain events, the events are weighted with the cosine of the angle between surface normal and wind direction. Although this weighting is part of the standard approach put forth by ISO 15927-3, the validity of the cosine weighting in a building context has been seriously questioned on the basis of CFD modeling⁵. The problem is partly addressed by ISO 15927-3 by a limitation of the summation to the interval $\pm 80^\circ$ around the surface normal.
- In both the expressions (1) and (2) the wind speed appears as the observation element FM , *i.e.* the average wind speed as measured 10 meters above terrain. To account for the reduction of wind speed closer to the ground, a power law type wind speed profile has been applied with an exponent value of 0.15 corresponding to a 3 cm terrain roughness consistent with a vegetation of short grass. Hence, the wind speed at height h above terrain has been estimated as:

$$U(h) = FM \left(\frac{h}{10m} \right)^{0,15}$$

In the treatment of the weathering experiments, the height of the experiment surfaces has been set to 2 meters.

- In cases where the available meteorological data is not collected in immediate vicinity of the experimental site or building site, it must be decided from the local topographical conditions if data from a nearby placed weather station is applicable. The problem is treated at a general level in ISO 15927-3 and it is discussed in further details by Rydock⁶.

1.2 UV radiation

The exposure of the experimental wood material to ultra violet (UV) radiation has been estimated by a calculation of the Sun's daily motion on the sky⁷ and a homogenous atmospheric model⁸. The horizontal coordinates (height and

⁵B. Blocken, J. Carmeliet: Building and Environment **41** (2006), 1182-1189

⁶J. P. Rydock: Building and Environment **42** (2007) 1229 - 1235

⁷P. Duffett-Smith: Practical Astronomy with your Calculator, 2nd Ed., Cambridge University Press, 1981

⁸Diaz *et al.*: Phys. Stat. Sol. (a) **139** (1993) 549-554

azimuth) of the Sun are calculated for the experimental site during a full year with 4 minutes interval. For each calculation point, the UV extinction of the Earth atmosphere is calculated using the Lambert-Beer law:

$$I(\lambda) = I_0(\lambda)e^{-\alpha(\lambda)ml_0} \quad (3)$$

with $I(\lambda)$ and $I_0(\lambda)$ denoting the radiation intensity at wave length λ at the surface of the Earth and outside the Earth atmosphere, respectively. $\alpha(\lambda)$ denotes the extinction coefficient at wave length λ , l_0 denotes the scale height of the atmospheric model and m denotes the air mass passed by the radiation.

In a homogeneous atmospheric model, the air mass, m is calculated from a simple geometric consideration:

$$m = \sqrt{\left(\frac{R}{l_0} \cos z\right)^2 + 2\frac{R}{l_0} + 1} - \frac{R}{l_0} \cos z \quad (4)$$

with R denoting the Earth radius and z denoting the Solar Zenith distance (*i.e.* the angle complementary to the Solar height). The atmospheric scale height, l_0 is set to 11km and the value of the extinction coefficient (αl_0) has been chosen as 1.1 corresponding to the average of values given by Diaz *et al.*⁹ at wave length 312nm. In relation to the calculation of UV exposure, the following points are to be observed:

- The homogeneous atmospheric model applied should be considered a very crude first approximation to the UV extinction. A better alternative is a layered model, *e.g.* DISORT¹⁰.
- No account has been made for the variation in the cloud coverage of the sky.
- No account has been made for the variation of atmospheric UV absorption due to varying atmospheric content of UV absorbing constituents (*e.g.* ozone and aerosols) or varying temperature.
- No account has been made for the variation in Solar emission or variation in the Earth-Sun distance.

2 Bar Charts

The exposure of a vertical surface (a plain wall) to the weathering factors WDR and UV radiation has been visualized as simple bar charts for the four

⁹Diaz *et al.*, *loc. cit.*

¹⁰K. Stamnes et al.: Applied Optics **27** (1988) 2502 - 2509

main surface normal directions (74° , 174° , 254° and 354°). For WDR, the height of a bar is directly calculated from (2) with summing over the full azimuth angle interval $\pm 90^\circ$ around the surface normal direction. The UV exposure of a surface has been calculated from horizontal Solar coordinates calculated with 4 minutes interval for a full year. For each of these calculation points with Solar azimuth in the interval $\pm 90^\circ$ around the surface normal and the Sun above the horizon, an UV exposure contribution is calculated as the atmospheric extinction factor according to (3) multiplied by cosine of the angle between surface normal and the direction to the Sun, i.e.

$$\cos h \cos(Az - \theta)$$

with h denoting the Solar height, Az denoting Solar azimuth and θ denoting the surface normal bearing.

3 Directional Weather Map

The Directional Weather Map visualizes the angular distribution of the three weathering factors WDR, UV radiation and wind in a single polar histogram.

3.1 The Wind Histogram

When constructing the wind histogram (wind rose), the horizon is divided into 36 angular sections each spanning 10° . The center azimuth value for a section is given by:

$$5^\circ + i \times 10^\circ; 0 \leq i \leq 35$$

Hence, the center azimuth value of the first section ($i = 0$) is 5° and 355° of the last section ($i = 35$). Correspondingly, the wind speed interval $[0 - 15\text{m/s}]$ is divided into 15 subintervals of width 1m/s . Hence, the wind speed center value of the subintervals are:

$$0, 5\text{m/s} + j \times 1\text{m/s}; 0 \leq j \leq 14$$

For each observation point, the associated azimuth section is determined from the element DM and the wind speed subinterval is determined from the element FM . With all observations thus classified in one of the $36 \times 15 = 440$ combinations of azimuth section and wind speed subinterval, the number of observations in each combination is counted. Since each observation represents a period of observation of one hour, a count represents the number of hours in the full period of the data time series where the wind has (on average) been blowing with speed in the associated subinterval and direction in the associated azimuth

section. By dividing each count with the ratio between the total number of data points in the time series, N_{Obs} and the number of nominal observations per year ($365, 25\text{d}/\text{y} \times 24\text{h}/\text{d} \times 1\text{Observation}/\text{h} = 8766\text{Observations}/\text{y}$), *i.e.* dividing by the ratio

$$\frac{N_{Obs}}{8766\text{Observations}/\text{y}}$$

the resulting quotients represent the average annual number of hours with wind speed in a given subinterval and wind direction in a given azimuth section. In the following, this quotient will be denoted *specific wind frequency*. The unit of this property is $\text{h}/\text{y}/10^\circ/(\text{m}/\text{s})$. By summing the specific wind frequencies within each azimuth section - *i.e.* summing over the 15 wind speed subintervals - the *wind frequency* is formed with the unit of $\text{h}/\text{y}/10^\circ$.

The specific wind frequencies are plotted in a polar diagram with the polar angle representing azimuth and the radial coordinate representing wind frequencies. In each of the 36 azimuth sections, the 15 associated specific wind frequencies are plotted according to subinterval center wind speed as wedge shaped sections with a radial extension according to the specific wind frequency. The sections are color coded according to the associated center wind speed value.

3.2 The WDR Histogram

To visualize the angular distribution of WDR, the amount of WDR is estimated for each time series data point according to the Lacy expression (1). As for the wind observations, the horizon is divided into 36 azimuth sections each covering 10° . The azimuth section of each data point is identified from the element DM and the amount of estimated WDR, RR_{WDR} is accumulated for each section giving the total amount of WDR on a surface facing the wind direction accumulated in each section during the full period of the data time series. By normalizing these amounts as above, *i.e.* dividing each accumulated amount by $\frac{N_{Obs}}{8766\text{Observations}/\text{y}}$, an estimate of the average annual WDR in each azimuth section is obtained. In the following these estimated annual average amounts are designated *WDR frequencies* with the unit of $\text{mm}/\text{y}/10^\circ$. The 36 WDR frequencies are plotted in the same polar diagram as the wind histogram: Each of the 36 WDR frequencies are shown as a point with azimuth angle as the center azimuth value of the azimuth section and the WDR frequency value as radial coordinate. The resulting 36 points are connected with straight lines.

3.3 UV Histograms

The angular distribution of the UV radiation is visualized analogously to the WDR visualization: Again, the horizon is divided into 36 sections each spanning 10° of azimuth angle. The results of a calculation of horizontal Solar coordinates and atmospheric extinction in 4 minutes intervals during a full year are accumulated in each section to give the relative annual UV exposure for Solar azimuth in each interval. For each interval, this accumulated relative exposure is plotted as radial coordinate and the center azimuth value of the interval as the polar coordinate. The resulting 36 points are connected with straight lines to form an exposure curve.

4 Surface Weather Maps

In order to visualize the WDR and Solar radiation (UV and visible light) exposure of specific surfaces of specific cladding geometries, WDR and radiation exposure have been visualized on surface maps. A surface is covered by a $1\text{mm}\times 1\text{mm}$ grid. To calculate the WDR exposure in a grid point, it is determined for each rain event, if the WDR direction estimated from the catch ratio according to the Lazy expression (1) allows the WDR to access the grid point. If the grid point is accessible for the rain event, the associated WDR amount weighted by the cosine of the angle between surface normal and estimated direction of incidence is added to the accumulated WDR exposure of the grid point. With WDR contributions of all rain events thus accumulated for all accessible grid points, a surface map plot is generated simply by applying a grey scale or color scale (Rainbow scale is typically used) to the accumulated contributions. Likewise for the surface maps for Solar exposure: For each calculated 4 minutes interval Solar position during a year, it is determined for each point of the grid if the point is accessible for the Solar radiation and in case it is, the cosine - and in case of UV exposure the atmospheric extinction - weighted contribution is added to an accumulated exposure for the grid point. After processing all Solar positions and all grid points, a surface map plot is formed as in the WDR case described above.

