

# HVDC Circuit Breakers: A Comprehensive Review

Fazel Mohammadi, *Senior Member, IEEE*, Kumars Rouzbehi, *Senior Member, IEEE*,  
 Masood Hajian, *Senior Member, IEEE*, Kaveh Niayesh, *Senior Member, IEEE*,  
 Gevork B. Gharehpetian, *Senior Member, IEEE*, Hani Saad, *Member, IEEE*,  
 Mohd. Hasan Ali, *Senior Member, IEEE*, and Vijay K. Sood, *Life Fellow, IEEE*

**Abstract**—High Voltage Direct Current (HVDC) systems are now well-integrated into AC systems in many jurisdictions. The integration of Renewable Energy Sources (RESs) is a major focus and the role of HVDC systems is expanding. However, the protection of HVDC systems against DC faults is a challenging issue that can have negative impacts on the reliable and safe operation of power systems. Practical solutions to protect HVDC grids against DC faults without a widespread power outage include (1) using DC Circuit Breakers (CBs) to isolate the faulty DC-link, (2) using a proper converter topology to interrupt the DC fault current, and/or (3) using high power DC transformers and DC hubs at strategic points within DC grids. The application of HVDC CBs is identified as the best approach that satisfies both DC grids and connected AC grids' requirements. This paper reports a comprehensive review of HVDC CBs technologies, including recent significant attempts in the development of modern HVDC CBs. The functional analysis of each technology is presented. Additionally, different technologies based on information obtained from literature are compared. Finally, recommendations for the improvement of CBs are presented.

**Index Terms**—DC Circuit Breakers (CBs), DC Faults, High Voltage Direct Current (HVDC) Systems, Multi-Terminal HVDC (MT-HVDC) Systems, Voltage Sourced Converter (VSC)-HVDC Systems.

## I. INTRODUCTION

THE fast development of power electronics technology and the urgent need for integration of large amounts of Renewable Energy Sources (RESs) have led to further developing and expanding High Voltage Direct Current (HVDC) systems. The fundamental advantages of HVDC systems are: (1) the

ability to connect long-distance underground/underwater cables, (2) fewer transmission lines required to transfer the same power compared to High Voltage Alternative Current (HVAC) systems, (3) the ability to connect asynchronous networks, (4) improve power flow controllability and stability, (5) preventing propagation of faults and disturbances between networks, (6) interconnection of multiple power generation units and/or loads at different DC voltage levels using high power DC transformers and multi-port DC hubs, and (7) reactive power support to interconnected AC grids during AC faults. Such advantages have led to an emerging need for the development of Multi-Terminal HVDC (MT-HVDC) systems [1].

MT-HVDC systems development is mainly possible using Voltage Sourced Converter (VSC) technology, in which power flow reversal on each terminal is achieved using DC-link current direction change [1]–[3]. Since VSCs are particularly vulnerable to DC faults, using fast detection and isolation mechanism is vital. Although fast DC Circuit Breakers (CBs) are now feasible, they are still in their infancy and are not yet commercially viable, and the only possible solution for isolating DC faults in HVDC links is to open CBs on the AC side [4]–[7]. However, this practice is not amenable for MT-HVDC systems because it can bring down the entire power flow of grids following a DC fault on a single DC cable or overhead link [8].

It is also noted that not only very large fault levels are expected following a DC fault because of low total line impedances of DC transmission links, but also a very fast Rate of Rise (RoR) of fault current is envisaged compared to counterpart AC systems. Furthermore, the stability of the interconnected AC systems may be adversely impacted by DC faults in MT-HVDC systems [9],[10]. This is of particular importance for connections to weak AC systems where long power disruptions due to DC faults can highly impact their stability. This issue implies that the application of fault-tolerant hybrid or full-bridge Modular Multilevel Converter (MMC) stations with conventional mechanical DC CBs cannot fully resolve the protection of such grids. While uncontrolled VSC operations discharging AC grids into a DC fault is avoided, AC power systems may not tolerate long power flow interruptions associated with the slow response of mechanical CBs. This further highlights the urgent need for a fast HVDC CB for such MT-HVDC systems deployment. Typically, the DC fault current has to be interrupted in less than 20 ms in total to limit them within their acceptable fault levels [11]. It should be noticed that the location of the DC fault within MT-HVDC grids is challenging [12],[13]. Another challenging issue in

Fazel Mohammadi (corresponding author) is with the Department of Electrical and Computer Engineering, University of Windsor, Windsor, ON N9B 1K3, Canada (e-mail: fazel@uwindsor.ca, fazel.mohammadi@ieee.org).

Kumars Rouzbehi is with the University of Seville, Seville 41092, Spain (e-mail: krouzbehi@us.es).

Masood Hajian is with the Department of Electrical and Computer Engineering, Isfahan University of Technology, Isfahan 84156-83111, Iran (e-mail: m.hajian@iut.ac.ir).

Kaveh Niayesh is with the Department of Electric Power Engineering, Norwegian University of Science and Technology, 7491 Trondheim, Norway (e-mail: kaveh.niayesh@ntnu.no).

Gevork B. Gharehpetian is with the Electrical Engineering Department, Amirkabir University of Technology (Tehran Polytechnic), Tehran 1591634311, Iran (e-mail: grptian@aut.ac.ir).

Hani Saad is with the Réseau de Transport d'Électricité, Paris 92932, France (e-mail: hani.saad@rte-france.com).

Mohd. Hasan Ali is with the Department of Electrical and Computer Engineering, University of Memphis, Memphis, TN 38152, U.S.A. (email: mhali@memphis.edu).

Vijay K. Sood is with the Department of Electrical and Computer Engineering, Ontario Tech University, Oshawa, ON L1H 7K4 Canada (e-mail: vijay.sood@uoit.ca).

Manuscript received November 04, 2020; Revised February 17, 2021.

a DC protection system is to distinguish between the faults on the AC and DC sides [14],[15] These all suggest an urgent need for fast and reliable DC CBs to be located at both sides of all DC transmission lines [16]. It is noted that applications of fault-tolerant DC transformers and DC hubs within DC grids are the other promising solutions for DC fault management. However, this is not a grid-wide solution and can only be used at strategic points of large-scale DC grids.

Conventional AC CBs employed in HVAC systems require 4-5 cycles (80-100 *ms*) to interrupt the fault current where interruption with minimal arcing is achieved using zero crossing of the fault current. Consequently, they are not capable of DC fault current interruption because of the lack of current zero crossing. They can be effectively adapted for DC systems if a passive or active resonant circuit is added enabling the required current zero crossing. Another advanced solution to deal with the fault current interruption in DC grids is the application of semiconductor-based HV CBs consisting of a series connection of multiple forced-commutated power switches, e.g., Insulated-Gate Bipolar Transistor (IGBTs). Nevertheless, this is an expensive solution considering the high operating costs associated with such conduction losses of CBs [17],[18].

Several research studies for DC CB design attributing fast and reliable performance have been reported so far. They incorporate applications of conventional AC interrupters, resonant circuits, fast mechanical CBs, semiconductor switches, charging units, varistors, etc., and they each have their own specific advantages and disadvantages. This paper aims at providing an overview of HVDC CBs technology from the beginning till today. It intends to identify areas that are relevant to this key technology, where research and development are required, and thus, reviving technical discussions on this subject. A thorough analysis and comparison between the state-of-the-art HVDC CBs are also presented to identify the areas where further research and development are required.

The rest of this paper is organized as follows. Section II presents HVAC/HVDC grids as a new paradigm in modern power systems. Sections III and IV review the design criteria for HVDC CBs and various types of HVDC CBs along with their characteristics, respectively. Different technologies/topologies for HVDC CBs are investigated in Section V. A comparison of various technologies for HVDC CBs is provided in Section VI. Available HVDC CBs in service are reported in Section VII. Recommendations for future research are determined throughout the paper and summarized in Section VIII. Finally, Section IX concludes this paper.

## II. HVAC/HVDC GRIDS—NEW PARADIGM

Electric power transmission in modern power systems relies on both AC and DC grids. The large integration of conventional energy sources and RESs, as well as power converters into power grids, has led to an emerging need for High Voltage (HV), Extra-High Voltage (EHV), and Ultra-High Voltage (UHV) hybrid AC/DC transmission grids and changes the modern power systems paradigm. Protecting HVAC/HVDC grids against faults both on the AC and DC sides is crucial to ensure the security and reliable operation of modern power systems [19],[20].

The interconnection of more than two HVDC terminals forms an MT-HVDC system with more functionality compared to point-to-point HVDC systems. The protection issue is the main barrier against the development of MT-HVDC grids. However, active research studies on both discriminative fault detection and fault isolation in large-scale DC grids are ongoing [21]–[23].

The old mechanical HVDC CBs were designed to protect Line-Commutated Converter (LCC)-based point-to-point HVDC grids while such CBs could not satisfy the requirements of VSC-based HVDC grids. The behavior of the power converter during DC faults should be considered as one of the main protection criteria. This is due to the fact that non-fault tolerant IGBT-based power converters are vulnerable to DC faults. The semiconductor switches of such converters are exposed to high currents during DC faults and if additional protective measures are not taken, such switches may not withstand more than a few milliseconds [24],[25]. Hence, it is vital to develop fast HVDC CBs to protect power converters. The application of Fault Current Limiters (FCLs) on the AC or DC side of power converters leads to reduced fault current RoR. It is worthwhile mentioning that the application of fault-tolerant VSCs and/or FCLs may reduce (1) the dependency on fast HVDC CBs [26] and (2) the size of CBs [27]. However, there is still a need for HVDC CBs to disconnect the faulty branch [22],[28]. Additionally, slow fault isolation may not be acceptable considering connected AC grids stability constraints.

## III. DESIGN CRITERIA FOR HVDC CIRCUIT BREAKERS

The major criteria for HVDC CBs design and deployment are given as follows:

### A. Fault Current Interruption Time

Fault current interruption time is the time interval from the fault inception till the end of CB breaking time, i.e., it is the aggregated protection operating time and breaking time of the CB. This should be kept below 5 *ms*, which is challenging when compared to counterpart AC systems [1].

### B. Maximum Current Breaking Capability

This is the maximum current that a CB is capable of interrupting without being damaged or leading to an electric arc with impermissible duration. This is typically much larger than counterpart AC systems due to the smaller total impedance of transmission systems. [1].

### C. Over-voltage Protection

Over-voltage protection is considered as operation when the voltage exceeds its predetermined value [1].

### D. Switching Losses

Such losses occur when the IGBT switches are transitioning from the conduction state to the blocking state, and vice versa. This transition is determined by a considerable voltage across the terminals of the IGBT switches and a major current passing through them [1].

### E. Fault Current Rate Limiting Reactor

A key element in the HVDC CB is the series rate limiting reactor. This component is used to allow a longer time for detection and isolation of fault current. Adding these reactors to MT-HVDC grids can cause unwanted oscillations between

VSCs' capacitors and such inductors, which may lead to an adverse impact on the grid stability. Furthermore, the traveling waves associated with the DC fault can be reflected by such inductors leading to a transient voltage rise at the DC CBs. The traveling wave effect can cause an initial faster RoR of current for a non-terminal fault that occurred far from the CB than a terminal fault. After a few milliseconds, the current eventually rises to a larger fault level in a terminal, than a non-terminal, fault as a result of the smaller series impedance between the fault and the converter. However, for that time interval, a non-terminal fault leads to a higher fault current. Since DC CBs must act within the first few milliseconds, this means from the protection point of view, a non-terminal fault can be the worst-case fault condition for such CBs. The sizing of such inductors is highly dependent on the discriminative detection system adopted, the DC cables' length, and maximum high impedance fault detection. Generally speaking, the lower the better performance of DC grids [1].

#### F. Maximum Dissipated Energy

A Metal Oxide Varistor (MOV) is utilized to damp large energy oscillations associated with fault current flowing through CB series inductor. This energy should be minimized to avoid the need for large bulky arresters. The power ratings of MOVs for continuous and transient current are significantly low and high, respectively. MOVs are capable of absorbing destructive energy and dissipating it as heat and thus, they protect vulnerable components and prevent major damage [1],[29],[30].

#### G. Total Cost

This is also of great importance considering the high number of components required in future MT-HVDC systems. Obviously, every effort must be made to keep the total cost low.

### IV. DIFFERENT TYPES OF HVDC CIRCUIT BREAKERS AND THEIR CHARACTERISTICS

Considering the design criteria presented in the previous section, DC CBs can be categorized into three main types: (1) Mechanical, including passive and active resonance circuits, (2) Solid-state, only relying on power electronics switches and (3) Hybrid DC CBs, involving a combination of power electronics and mechanical disconnectors [31],[32]. The mechanism of each of the mentioned DC CBs are given as follows:

#### A. Mechanical DC Circuit Breakers

Mechanical CBs are appropriate for applications at the medium voltage and power levels. The principle of operation of such CBs is based on creating a current zero using a resonant circuit [33],[34]. There are three major paths in mechanical CBs that the current can pass through: (1) the main branch consisting of a low-resistance mechanical interrupter, e.g., an AC Vacuum Interrupter (VI) [35], (2) the current injection path consisting of an *LC* resonant circuit, [36], and (3) the energy absorption branch consisting of single/multiple banks of surge arrestors. Mechanical CBs can be classified into two major categories, as follows:

##### 1) Passive DC Circuit Breakers

In passive CBs, a branch consisting of an inductor in series with a capacitor is connected in parallel with the *SF<sub>6</sub>* CB, as shown in Fig. 1(a) [37]. Such a circuit may lose its stability

under certain conditions and large oscillations may develop till current zeros are created and the electric arc is extinguished. When the electric arc is totally extinguished, the capacitor starts charging instantly until the non-linear resistor, MOV, controls the current and limits the voltage to a certain range. In addition, the energy is dissipated in the non-linear resistor.

It should be noted that if the instantaneous rate of voltage change versus current change ( $dU/dI$ ) becomes negative, the discharged current through the electric arc with a parallel capacitor starts oscillating leading to an undesired current chopping in AC systems [38], while it can be used for DC current interruption.

##### 2) Active DC Circuit Breakers

The active DC CBs are used to create current zero crossing when the level of DC fault current is above the instability limit. The commonly used structure for an active DC CB is to place a pre-charged capacitor into the auxiliary circuit once both the length of the electric arc and the blast pressure in the *SF<sub>6</sub>* CB are sufficient. Fig. 1(b) shows the typical structure of an active DC CB [37].

If either a passive or active DC CB is being used for VSC-based HVDC systems without current limiting inductors, a large capacity should be considered while selecting the inductor (*L*) and capacitor (*C*). Additionally, the action speed of such CBs is much lower compared to the DC fault current RoR, with their interruption time in the order of 30-50 *ms*. This makes them unsuitable for VSC-HVDC systems [39].

#### B. Solid-State DC Circuit Breakers

Solid-state DC CBs consist of two or more solid-state based high voltage valves that are capable of interrupting the DC fault current much faster than mechanical DC CBs without requiring a current zero crossing [21],[22],[40]–[42]. The desired current breaking capability can be achieved by properly configuring the switches in solid-state DC CBs. To bidirectionally interrupt the fault current, it is mandatory to use two back-to-back high voltage valves, each consisting of hundreds of IGBT switches, for solid-state DC CBs. Fig. 1(c) shows the typical topology of a solid-state DC CB consisting of two branches [43]. The main breaker is supported by a parallel surge arrester to avoid high voltage valve over-voltage damage at fault current interruption time. The voltage and current ratings of the solid-state CB determine the number of valves. The current flows through the valves during the normal operation and in the case of a DC fault, the valves are turned off and block the current flow. Then, the parallel MOV limits the voltage across the breaker valves. Compared to the mechanical DC CBs, solid-state DC CBs are faster in terms of operation time.

The thermal limit of the IGBT switches is not significant. To dissipate a large amount of energy issue, the IGBT switches should be connected either in series and/or parallel. The HV valves are to be designed for hundreds of kVs in future MT-HVDC systems using commercially available IGBTs up to a few kVs. Thus, a chain of IGBTs is required for CB valves, which results in high total cost and power losses. The static and dynamic voltage sharing between individual IGBTs of CB high voltage valves is another issue, which adds to its complexity. While much faster fault isolation is achieved,

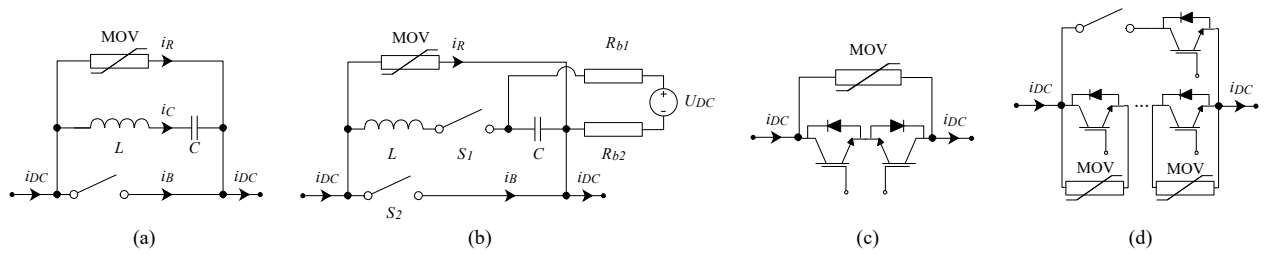

Figure 1. Typical structures of DC CBs: (a) Passive, (b) Active, (c) Solid-State, and (d) Hybrid.

the conduction losses are too excessive and unacceptable compared to mechanical DC CBs [43],[44]. Additionally, they suffer from much less reliability compared to mature mechanical CB technology. Consequently, solid-state CBs are not a suitable option for MT-HVDC grid applications [37].

### C. Hybrid DC Circuit Breakers

Hybrid DC CBs are the third category of HVDC CBs obtained from combining mechanical and solid-state DC CBs, having the advantages, such as faster operation time, higher current breaking capability, and less power losses [23],[24]. Mechanical DC CBs are cheaper but their operation speed is too slow. On the other hand, solid-state DC CBs are faster to interrupt the DC fault current while in the case of a complicated configuration for VSC-HVDC systems, their total cost and power losses (due to the existence of permanent resistance) are high. The operation of hybrid DC CBs is based on using a low impedance path for current in the normal operation and redirecting it to a solid-state high voltage valve in the event of a DC fault [45]. Fig. 1(d) illustrates the typical topology of a hybrid DC CB [45]–[48].

## V. VARIOUS TECHNOLOGIES/TOPOLOGIES FOR HVDC CIRCUIT BREAKERS

### A. Electromechanical DC Circuit Breakers

An electromechanical DC CB with a pre-charged capacitor [49] is a traditional mechanical DC CB for HVDC grid applications. While the topology with a pre-charged capacitor involves an active commutation mechanism relying on a charging auxiliary circuit, a non-pre-charged capacitor option is equipped with a passive commutation mechanism. The counter-current magnitude is dependent on the surge impedance of the discharge branch and the voltage of the capacitor. Accordingly, in [50], the values of such components are optimally selected to improve the performance of the electromechanical CB in the active commutation scheme. In [51], an electromechanical DC CB using non-linear resistors and commutation switches in the parallel path is proposed. Saturable reactors are good candidates in electromechanical DC CB to minimize the size of both the inductor and capacitor of the active resonant circuit and reduce the cost of implementation of such DC CBs [39]. The application of Crossed Field Interrupt (CFI) tubes in mechanical DC CBs with the aim of faster fault current interruption is studied in [52], and it is shown that the fault current interruption time is approximately 60 ms. [53],[54] The disadvantage of this method is the delay incurred in opening the metallic contacts. Correspondingly, this issue is addressed in [55] using fast hydraulic actuators, four  $SF_6$  interrupters, and four VIs.

It is worth mentioning that a reliable DC CB should tolerate transient recovery voltage after fault current interruption [56]. In [57], the performance of the VI and gas interrupter considering transient recovery voltage after fault current interruption is analyzed. In [58], the topology of a mechanical DC CB considering trigger gap, pulse transformer, and blocking capacitor with shunt arrangement of the surge arrester is investigated. Using the modified topology presented in [58], by changing the arrangement of the surge arrester branch, a 1.2 kA at 250 kV DC CB is implemented in [57]. Another attempt using a VI with the presented topology in [58] is made in [59], which led to developing a prototype of 10 kA at 3.3 kV DC CB. Using the basic principles of the mechanical DC CB, a prototype is tested in [60] for the DC fault current interruption of 8 kA at 250 kV. Another configuration for DC CB is based on airblast breaker units. In [61], a prototype of 2 kA at 500 kV DC CB using four airblast breakers in terms of the main interrupters in series connection is developed, and in [62], the maximum current breaking capability of the airblast mechanical DC CB is increased to 4 kA. In [63], a 500 kV HVDC CB for switching the load and fault current interruption up to 2.2 kA is implemented. A hybrid topology consisting of a mechanical switch, an arrester, and a snap-off diode is investigated in [64]. In this configuration, the diode should be charged by a high current pulse in the forward direction prior to opening the mechanical CB contacts. In [65], a topology based on a series connection of VI units for DC CB development is proposed. In addition, the series connection of a VI unit and an  $SF_6$  interrupter unit for a DC CB is considered in [66]. The main consideration in [66] is that the insulation characteristics and the arc characteristics of the VI unit and  $SF_6$  interrupter should be coordinated.

In the past few years, several attempts have been made to model mechanical DC CBs [67],[68]. The optimal design of the active commutation branch in terms of reducing the commutation period and improving the interruption probability for mechanical DC CBs is investigated in [69]. In [70] and [71], different topologies for mechanical DC CBs with the aim of reducing the ratings of required semiconductor devices are proposed. Such DC CBs use VI units for the main interrupter implementation and generate the counter-current using a power electronics-based converter. In [72], the multiple series gaps are used to design the active resonance circuit. In [73], the bidirectional current breaking capability of mechanical DC CBs is studied. In addition, topologies for active resonance mechanical DC CBs are proposed in [74] and [75]. Their main drawback is the inability to successfully interrupt the load current during the normal and over-current fault conditions.

The investigation on safe stroke as a breaking parameter of mechanical DC CBs is presented in [76]. In [77], the transient current interruption characteristics of a mechanical DC CB are analyzed and evaluated by software simulation models. In [78], an arc-induced DC CB consisting of mechanical contacts, induction needles, an induction ring, and a ground line, as a mechanical CB for DC grids is proposed. In [79], two HVDC CBs for DC fault current interruption are proposed. In the proposed DC CBs, a current limiting inductor, a current control inductor, mechanical switches, and a multilevel converter with phase-shifted carrier modulation, are employed.

In all mentioned designs, the current interruption occurs in the mechanical switch responsible for carrying the current, and therefore, the switching arc plays a key role in its behavior, similar to conventional HVAC CBs. This imposes high demands on the fast recovery of the switching gap and causes considerable limitations in the maximum interruptible current of this type of HVDC CBs. Moreover, the relatively slow opening of the mechanical CBs leads to high spontaneous arc currents and most likely to a failure in current interruption, especially in grids with high RoR of fault current. This limits the applicability of mechanical HVDC CBs to load current interruption, e.g. metallic return transfer switches or fault current interruption (up to a few kA) in grids with high fault impedances.

### B. Solid-State DC Circuit Breakers

The semiconductor switches are the main components in purely solid-state DC CB for the fault current interruption [44],[80]. The basic configuration of a solid-state DC CB comprises a series connection of semiconductor switches in the main current branch. Such switches can be IGBTs [81], Gate Turn-Off Thyristors (GTOs), or Integrated Gate Commutated Thyristors (IGCTs) [82] and they must be opened when the trip signal is sent. If the semiconductor switches are open, the current flows into the surge arrester branch [44]. Due to the current interruption, the voltage across the solid-state DC CB increases to a level clamped by surge arresters. The transient recovery voltage of a solid-state DC CB, which is determined by the surge arrester over-voltage protection, can be used to specify the voltage rating of the main CB unit of solid-state DC CB [44],[83],[84]. The snubber circuit can be used to achieve equal static and dynamic divisions across the switches connected in series [81]–[85]. Using active driving signal adjustment methods, the voltage unbalances due to the difference in the true values of the snubber circuit components can be minimized [86]. In [84] and [87], the proposed configurations of solid-state DC CBs are based on placing surge arrester branch in series and shunt connections with a diode stack and the load side of the main CB, respectively. In [88], a topology for a solid-state DC CB aiming at removing the surge arresters by adopting two coupled inductors, a capacitor, and a diode, is proposed. The design consideration, protection method, and validation testing of a solid-state DC CB for DC shipboard power systems are presented in [89].

In [90], it is proposed to employ thyristors in the main CB of solid-state DC CB while the inability to turn off the thyristors using the gate signals is a major challenge. To resolve this issue and provide conditions for forced commutation of

thyristors, it is suggested in [91] to use fully rated components in the auxiliary circuits. This issue can be resolved using Z-source inverters in the design consideration [92]. The typical configuration of a Z-source solid-state DC CB includes a thyristor, a crossed LC branch, resistors, and diodes [93]. During the normal condition, the thyristor is in conduction mode, and the current flows through the thyristor. In the event of the DC fault, the current rapidly increases, but the inductors prevent sudden changes in the current, and the fault current flows through capacitors, which are already charged up to the DC voltage level and discharging into the fault impedance. Hence, the thyristor current drops below its holding value, and it turns off. An auxiliary circuit detects the thyristor current dropping to zero and avoids sending any further gate pulses. The two LC circuits subsequently resonate causing the stored energy to dissipate in the fault impedance. This also causes a positive cathode to anode voltage across the thyristor for a small portion of time when the reverse recovery of the switch is achieved. The current and voltage capabilities of DC CBs can be increased by connecting the Z-source inverters in series or parallel. Compared to the typical solid-state DC CBs, Z-source solid-state DC CBs have the following drawbacks:

- Conventional Z-source solid-state DC CBs are not capable of bidirectional fault current interruption.
- Load current interruption cannot be performed using Z-source solid-state DC CBs.
- The Z-source solid-state DC CBs are not capable of receiving the trip signal for fault current interruption.
- If the Z-source solid-state DC CBs are connected in series, in case of the fault condition, the closet Z-source solid-state DC CB can be turned off.
- The proper operation of Z-source solid-state DC CBs is highly dependent on the RoR of the fault current.
- The allocation of the conventional Z-source solid-state DC CBs should be on both poles of the transmission line.

In [94] and [95], modified topologies of Z-source solid-state DC CBs are proposed, in which the size of the capacitor is inversely proportional to the magnitude of fault current and the size of the inductor. In [42] and [96], other alternative designs of Z-source solid-state DC CBs are investigated. The bidirectional power flow problem of Z-source solid-state DC CBs is studied in [41]. Considering the limitations of Z-source solid-state DC CBs, the majority of the proposed topologies are applicable to the medium and low voltage DC grids [97]. In [98], analysis and experimental verification of bidirectional Z-source DC CBs are performed. The optimization and control of a Z-source DC CB with the aim of reducing the switching losses of the protection device are analyzed in [99]. A bidirectional series Z-source CB to disconnect the DC faults autonomously is proposed in [100]. A combination of a thyristor and IGBT as an active Z-source DC CB is proposed in [101].

As mentioned earlier, high power losses are considered to be a dominant issue in solid-state DC CBs while such CBs are used as neutral bus switches for HVDC grid applications. The neutral bus switches are essential in clearing DC faults in point-to-point VSC-HVDC systems. Using solid-state DC

CBs as neutral bus switches can enhance the fault current interruption capability of neutral bus switches. As a result, DC faults can be isolated before the operation of AC CBs [102]. To reduce the switching losses in solid-state DC CBs, wide band gap power devices are investigated [103],[104]. Compared to the conventional solid-state DC CBs, wide band gap power devices can be implemented with higher blocking voltage levels and reduced power losses. In [105], a 22 kV Silicon Carbide Emitter Turn-Off (ETO) thyristor as a single switching device is presented. A typical configuration of a wide band gap-based solid-state DC CB is presented in [106]. In addition, the external power requirements of wide band gap-based solid-state DC CBs are studied in [107]. A Silicon Carbide Junction Gate Field-Effect Transistor (JFET)-based solid-state DC CB with a digitally controlled current-time profile is proposed in [108]. The proposed self-powered DC CB can be used for over-current protection, as well as ultra-fast short circuit protection.

DC/DC converters are capable of limiting and interrupting the DC fault current and hence, they can be used as DC CBs [43]. In [109], a thyristor-based bidirectional DC/DC converter for HVDC systems is proposed, in which the converter regulates the power flow and isolates the faulty section of DC grids without impacting the rest of grids. As thyristors are used in this topology, the power losses are low, and bidirectional power flow can be achieved. In [110] and [111], the dual active bridge DC/DC converter and bidirectional DC/DC converter as DC CBs are proposed. In [112], a double switch topology of a DC/DC converter along with some modifications is presented. In [113], a bidirectional LLC DC/DC converter as a DC CB is investigated. The proposed converter is designed to minimize the physical footprint and maximize operational efficiency. However, in this topology, a special transformer with certain insulation requirements is needed. A topology for high-power DC hub implementation enabling connection of multiple HVDC links is presented in [114], in which fault isolation from each port is achieved.

In [115], the configuration of solid-state DC CB based on coupled inductors is proposed. During the normal condition, the fast disconnecter is closed, and both the load commutation switch, including a few series-connected IGBTs, and the main breaker (auxiliary current branch), consisting of hundreds of high voltage IGBTs, are turned on. As the impedance of the auxiliary current branch is much higher than the main current branch, consisting of the fast mechanical disconnecter and load commutation switch, the majority of the current flows through the main current branch resulting in very low conduction losses compared to a pure semiconductor-based breaker. In the event of a DC fault, the current within both branches increases rapidly. Once the DC fault is detected within microseconds, the load commutation switch is switched off, while the main breaker remains closed. Subsequently, the fast mechanical disconnecter opens at zero current without arcing within a few milliseconds. Once the fast mechanical disconnecter is completely opened, the main branch breaker is tripped to successfully interrupt the DC fault. Finally, the current rate limiting inductor energy associated with interrupted fault current is dissipated in the surge arrester bank and

the fault is cleared within 2–5 ms. While a bidirectional CB provides comprehensive protection for internal and external faults, a unidirectional one incurring less total cost and losses is recognized as the best choice in meshed DC grids. In this way, the backup protection against reverse fault currents associated with external faults is achieved using an HVDC CB located at the remote side of DC cables. The main issue in the configuration proposed in [115] is its inability to provide bidirectional power flow. In [116], the existing inductors in Z-source converters are employed as coupled inductors, which leads to reducing the size of inductance used in solid-state DC CB by almost 30%.

### C. Hybrid DC Circuit Breakers

Hybrid DC CBs, as the latest technology, benefit from low power losses and fast operation speed. They have a current branch with low power losses (recognized as the main branch), a semiconductor-based CB (recognized as the auxiliary branch), and an energy absorption branch to limit voltage spikes at CB tripping instant [1]. The main difference between mechanical DC CB and hybrid DC CBs topologies is that in mechanical DC CBs, the current interruption is performed inside the mechanical interruption unit. The parallel branch cannot interrupt the current while generates a counter-current opposite to the DC fault current [1]. The main characteristic of hybrid DC CB topologies is the fault current interruption in an auxiliary branch, which is connected to the main conduction path in parallel.

In [45]–[47], the basic configuration of a hybrid DC CB for DC applications is studied. In [117], the applicability of the basic configuration of the hybrid DC CB for DC applications at medium voltage level is studied. In [118], the basic configuration of a hybrid DC CB using VI and Silicon Carbide-based semiconductor switching devices is investigated. In [119], a prototype implementation of the hybrid DC CB for interrupting 10 kA fault current at 1 kV is reported. The main issue in the basic topology of a hybrid DC CB is the risk of commutation failure at higher voltage levels. High voltage applications require hundreds of IGCTs and IGBTs in series connection to withstand the transient recovery voltage. Then, the voltage drop across the semiconductor-based CB increases, and this may lead to arcing. In the case of a lower level of arc voltage than the voltage drop across the semiconductor-based CB, it is not possible to redirect the current into the semiconductor-based CB (auxiliary branch), and this can cause a commutation failure. The performance analysis and experimental validations for IGCT, IGBT, Injection-Enhanced Gate Transistor (IEGT), and Bimode Insulated Gate Transistor (BIGT) in hybrid DC CBs are presented in [120],[121]. A coupled inductor-based hybrid DC CB with zero current switching is proposed in [122]. The proposed topology is capable of interrupting the DC fault current, as well as mitigating the requirement of MOV for network demagnetization.

An improved hybrid DC CB, known as proactive hybrid DC CB, with its detailed description are reported in [21]. In this configuration, the main current branch consists of a fast mechanical disconnecter in a series connection to a load commutation switch. During the normal condition, the fast disconnecter is closed, and both the load commutation switch

and the main breaker (auxiliary branch, which consists of IGBTs or IGCTs switches) are turned on. As the impedance of the auxiliary branch is higher than the main current branch, the majority of the current flows through the main current branch. In the case of a DC fault, the current in both branches increases rapidly. Once the DC fault is detected, the load commutation switch turns off, and the main breaker should be closed. By opening the load commutation switch, the voltage across it increases rapidly, and the fast mechanical disconnecter opens at zero current without arcing. Once the fast mechanical disconnecter is completely opened, the auxiliary branch should be opened to successfully interrupt the DC fault. After that, the current flows through the surge arrester branch and can be diminished. The operation time of a fast mechanical disconnecter can be as much as 2 ms [7],[21]–[23],[48],[83]. The proposed proactive hybrid DC CB, which does not include a fast mechanical disconnecter, is capable of interrupting 9 kA fault current at 80 kV. In [48], the proactive hybrid DC CB, including a fast mechanical disconnecter is implemented. It is indicated that for 1 kA commutation current at 300 kV, the peak voltage across load commutation switch does not exceed 3.5 kV. Therefore, a few semiconductor switches connected in series should be used in the load commutation switch development, which is of great advantage for DC CB improved efficiency [16]. Another hybrid DC CB using VI and Silicon Carbide-based semiconductor switching devices is proposed in [123].

Several research studies are conducted to analyze the different aspects of utilizing proactive hybrid DC CB, such as current commutation process in proactive hybrid DC CB [16],[123], the integration of proactive hybrid DC CBs to MT-HVDC systems [124]–[127], and detailed modeling of proactive hybrid DC CB [128]–[131]. In [132], a self-powered IGBT gate driver circuit design for hybrid DC CB applications is investigated. Different load current commutation schemes using thyristor, inductor, pre-charged capacitor, and diode, are proposed in [133] while their main drawbacks are the longer breaking time and the complexity of the control process in the case of bidirectional power flow. A topology of hybrid DC CB similar to the proactive hybrid DC CB is proposed in [134], in which the main difference is in the CB that uses thyristors, capacitors, and surge arresters. A prototype of this topology is developed to interrupt the 7.5 kA fault current at 120 kV. In [135], another topology of a hybrid DC CB is presented, and based on the reported simulation results, at 500 kV, the proposed DC CB shows a maximum of 800 kV transient recovery voltage.

In [136], an alternative configuration of a hybrid DC CB utilizing full-bridge sub-modules in the load commutation switch and mechanical CB is investigated. The experimental results illustrate successful fault current interruption of 15 kA within 3 ms, and the transient recovery voltage across the proposed DC CB is 75 kV. The main drawback of the proposed topology in [136] is the higher development cost as a result of using full-bridge submodules in the main branch. In [137], a thyristor-based hybrid DC CB for fault current interruption is presented. Another topology of current commutation circuit for hybrid DC CB is presented in [138],[139] and implemented

for current commutation of 3.4 kA at 44 kV within 130  $\mu$ s. The topology of an H-bridge-based hybrid DC CB is presented in [140]. Compared to the proactive hybrid DC CB, the proposed topology in [140] uses fewer number of semiconductor switches in the CB but it needs two extra fast mechanical disconnecter units, which leads to an increase in the implementation cost. The other attempt to reduce the number of gate-controlled semiconductor switching devices in the CB is made in [141] by proposing a topology based on Silicon Carbide-based semiconductor switches. In [142], two topologies of bridge-type integrated hybrid DC CBs with the aim of reducing the number of semiconductor switches are proposed. In [143], the traditional half-bridge MMC is modified to be used as an auxiliary DC CB for HVDC grid applications.

In [24], the configuration of a hybrid DC CB aiming at reducing the cost of implementation considering less interruption time, as well as less power losses, is investigated. This topology consists of an active short circuit breaker, mechanical CB, fast mechanical disconnecter, and accessory discharging switch. In [144], a topology based on a thyristor-controlled resistor in series connection with the current limiting inductor of a hybrid DC CB is proposed. This topology is capable of minimizing the amount of absorbed energy in the surge arresters and can be used in VSC-HVDC systems. In [145], the conceptual topology of a bidirectional hybrid DC CB for the quench protection circuit is presented. A systematic study on modeling and control of hybrid DC CB based on fast thyristors is provided in [146]. The parameters of the proposed DC CB are determined for a 120 kV, 1.5 kA test CB with an interrupting DC fault current of 10 kA.

#### D. Other Types of DC Circuit Breakers

A current limiting DC CB is capable of limiting fault current or its RoR. The fault current limiting at different voltage levels can be performed using a driver circuit for semiconductor switches for a limited time interval [147]. The fault current limiter can be used in DC CBs for HVDC grid applications, as well. For such applications, a fault current limiter consists of inductive, resistive, or superconducting components to limit the fault current or its RoR [148]–[154]. There are two types of superconducting fault current limiters, called quench and non-quench types [155].

Several research studies are carried out to analyze the characteristics of DC current limiting of various superconducting fault current limiters. These include DC dual reactor type based on switching mode of high-temperature superconducting components [155], DC type superconducting fault current limiter consisting of superconducting transformer [156], and DC resistive type superconducting fault current limiter [157]. In addition, the applications of superconducting fault current limiters in DC grids, such as DC grids equipped with slow mechanical CBs [158], point-to-point VSC-HVDC systems [159], and MT-HVDC systems [160], are investigated. In [161], modeling and analysis of superconducting fault current limiters for HVDC systems are presented. In [162], the Yttrium Barium Copper Oxygen-coated conductor tape as a resistive type of superconducting fault current limiter is determined as a good candidate for HVDC grid applications. In [163],

a study on the parameter matching between active saturated Iron-core superconducting fault current limiter and DC CBs is conducted. In addition, the characteristics of DC CB using transformer-type superconducting fault current limiter for DC fault current interruption are analyzed in [164]. An artificial current zero crossing DC CB based on superconducting fault current limiter without the need for an external charging device is pretended in [165]. Due to the fact that conventional thyristor-based DC fault current limiters are not capable of interrupting a permanent fault, in [166], the integration of DC CB and the fault current limiter based on zero-voltage resonant switching technique is investigated.

The combination of superconducting fault current limiters and various topologies of DC CBs is suggested in [167]. It is reported in [168] and [169] that the combination of the resistive type of superconducting fault current limiter in a series connection with a mechanical CB can reduce the fault current interruption requirements of VI. In [170], the superconducting fault current limiter-based mechanical CBs are used in the selective protection of MT-HVDC systems. The combination of superconducting fault current limiters and hybrid DC CBs can reduce the overall required current interruption capability. In this case, a proactive hybrid DC CB with a superconducting fault current limiter in the main branch is proposed in [171] and the feasibility analysis of this configuration is performed in [172]. Also, the impact of superconducting fault current limiter on fault current interruption in MT-HVDC systems using continuous wavelet transform protection scheme and the proactive hybrid DC CB is investigated in [173]. It is shown that superconducting fault current limiter significantly reduces the DC fault current interruption requirements of hybrid DC CBs. In [174], a module for reciprocating the topology of HVDC CB, in which the connections of branches can toggle between series and parallel modes, for limiting the RoR and interrupting the DC fault current is presented. In [175], the design and experimental validations of a superconducting hybrid DC CB consisting of a Magnesium Diboride coil, a VI unit, and an IGBT module are provided. In [176], a passive resonance DC CB considering Carbon Dioxide/Oxygen mixed gas with superconducting fault current limiter is proposed.

#### VI. COMPARISON OF VARIOUS TECHNOLOGIES FOR HVDC CIRCUIT BREAKERS

According to the research studies in the literature and considering the mentioned design criteria in Section III, as well as voltage and current ratings and total cost, the comparison among different technologies for DC CBs based on their characteristics, is summarized as follows:

- Mechanical DC CBs, including passive and active ones, are capable of interrupting DC fault current within 60 *ms*. For such DC CBs, the required commutation time for contact separation is 20 *ms*. In addition, the required energy absorption time for passive and active DC CBs are 30 *ms* and 2 *ms*, respectively. The maximum rated voltage of mechanical DC CBs is 550 kV and they can be employed as metallic return transfer breakers. The maximum current breaking capability of such DC CBs is up to 4 kA (if active DC CBs are used, this value

may increase to 8 kA). The expected power losses of mechanical DC CBs compared to VSC-HVDC systems are  $\leq 0.001\%$  (only because of metal contacts existence).

- Solid-state DC CBs interrupt DC fault current in 1-2 *ms* in total. The required commutation time for solid-state DC CBs is 0.1 *ms*. Furthermore, the required energy absorption time for such CBs is approximately 1 *ms*. So far, solid-state DC CBs are not applied to conventional HVDC systems. However, the prototype solid-state DC CBs have the maximum rated voltage and the maximum current breaking capability of 800 kV and  $\sim 6\text{--}12$  kA, respectively. As the semiconductor switches are connected in series, the expected power losses of solid-state DC CBs compared to VSC-HVDC systems are considerably higher, i.e.,  $\leq 30\%$ .
- Hybrid DC CBs can interrupt DC fault current within 2 *ms*. The required commutation time for contact separation and fast mechanical disconnecter in hybrid DC CBs are 0.2 *ms* and 1 *ms*, respectively [1]. Moreover, the required energy absorption time for such CBs is in the range of 1 *ms*. Successful results achieved by testing hybrid DC CBs at downscaled voltage-ratings. The maximum rated voltage of such DC CBs is 320 kV and their maximum current breaking capability is estimated between 9 and 20 kA. There are only a few IGBTs in series connection in the main branch and as a result, the expected power losses of hybrid DC CBs compared to VSC-HVDC systems are  $\leq 1\%$ .

#### VII. AVAILABLE HVDC CIRCUIT BREAKERS IN SERVICE

The number of HVDC CBs in service is indeed limited. Therefore, the well-known and successful applications are discussed in this section.

A prototype active current injection DC CBs have been used in  $\pm 160$  kV Nan'ao three-terminal flexible DC project in China [177]–[179]. In addition, prototype 5 kA DC commutation CBs have shown an acceptable performance in the west-to-east UHV DC power transmission project from Xiluodu (Southwest China) to Zhejiang (East China) [180]. The prototype hybrid DC CBs have been installed for the protection requirements of Zhoushan  $\pm 200$  kV five-terminal HVDC systems in China [181]. Sixteen prototype DC CBs have been used in the  $\pm 500$  kV Zhangbei four-terminal HVDC systems in China [182].

Different types of DC CBs for various applications in HVDC systems are under development. In order to provide a relative comparison, HVDC CBs designed and implemented by ABB [21],[48], Alstom Grid [134], and Siemens [183],[184] are discussed in this paper. Figs. 2 and 3 show the structure of ABB and Alstom Grid HVDC CBs, respectively. The DC current breaking method used in both DC CBs is the current commutation scheme. The main branch in both DC CBs consists of one fast mechanical disconnecter in series connection with at least two anti-series connected IGBTs. The main components in the auxiliary branch of the ABB HVDC CB are IGBTs while thyristor stacks in series connection with a capacitor are used in the Alstom Grid HVDC CB. For energy dissipation, the third branch of the mentioned DC CBs



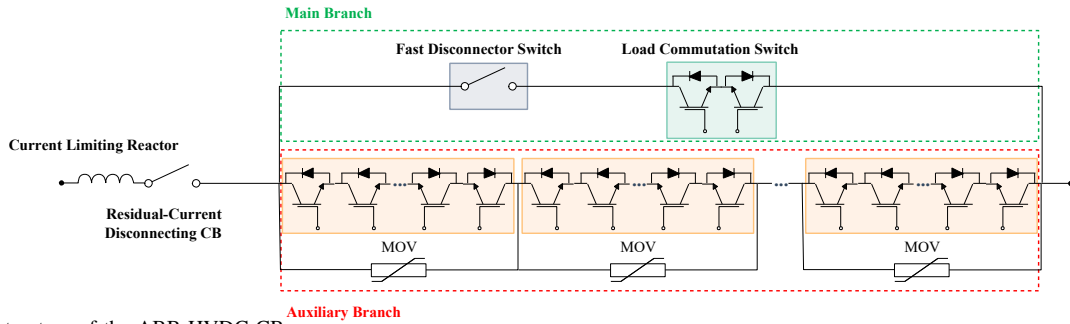

Figure 2. The structure of the ABB HVDC CB.

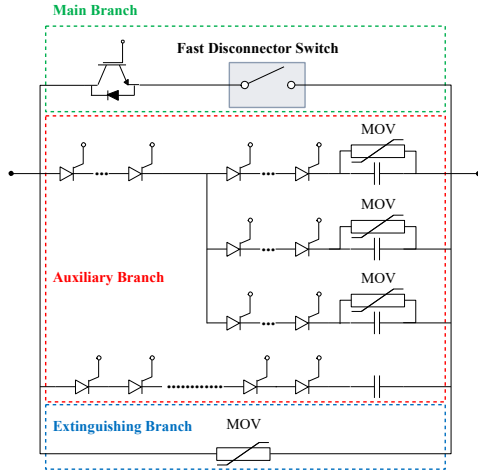

Figure 3. The structure of the Alstom Grid HVDC CB.

consists of MOVs with a proper voltage rating. Depending on the number of components used in the main and auxiliary branches, the cost of implementation increases. As the voltage increases, the ABB HVDC CB requires more IGBTs while the Alstom Grid HVDC CB needs more thyristor stacks, as well as a capacitor with large capacity.

The main characteristic of the ABB HVDC CB is its capability of fast switching because of the IGBT switches. However, in the case of DC faults, IGBTs cannot withstand the high peak current. On the contrary, the Alstom Grid HVDC CB uses thyristors that can tolerate a high fault current, but turning thyristors off is a major challenge. In addition, to automatically turn off the Alstom Grid HVDC CB, a series capacitor is needed that can help to reduce the DC fault current to zero. The switching losses and fault current interruption time of the ABB HVDC CB are higher than the Alstom Grid one. The ABB HVDC CB is suitable for HVDC systems with fast DC fault current interruption capability and the Alstom Grid HVDC CB is useful for protecting HVDC systems if a longer time delay is required.

As shown in Fig. 4, the structure of the Siemens HVDC CB is similar to the ABB one but instead of power electronics switching devices in the auxiliary branch, an uncharged capacitor is used. In this structure, damping resistors and MOVs are also employed. A controller is considered to open the mechanical switch once the auxiliary electronics-based DC switch opens. Alternatively, the auxiliary electronics-based DC switch can be opened immediately subsequent to opening the mechanical switch.

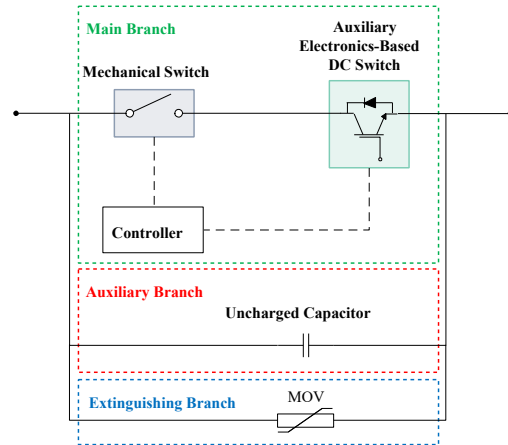

Figure 4. The structure of the Siemens HVDC CB.

### VIII. RECOMMENDATIONS FOR FUTURE RESEARCH

As mentioned earlier, the main barrier against the development of HVDC systems is to find the techno-economic justifications to build such systems and the supplementary cost for HVDC CBs required in such modern power systems. It is worth-mentioning that HVDC CBs are still immature, and they need to be substantially improved before industry-wide acceptance. An evaluation of the previous sections reveals the following concerns:

- *Scalability*: Most of the case studies are small-scale testbeds and prototypes and are subject to specific laboratory conditions with limited capabilities. The wider ranging test experience from real-world applications is limited.
- *Robustness Assessment*: Robustness is a quantifiable concept. Nevertheless, in many research studies, the robustness of the proposed DC CBs is not clearly determined. Obviously, there is not a perfect universal DC CB that would fit all needs in HVDC systems. Hence, the limitations of the proposed DC CBs should be discussed along with the conditions to which the DC CBs are proved to be robust.
- *Evaluation Approach*: Laboratory-based DC CBs are commonly proposed as case studies to evaluate their effectiveness. Real-world existing grids are not as simple as limited laboratory-based systems and they may exhibit features that may have been over-looked. As an example, in many research studies, back-to-back and/or simultaneous DC faults in different parts of DC grids are not considered which may be possible conditions

in real-world power systems, such as DC fault current propagation.

Considering the research studies reported in the literature, future developments of HVDC CBs should be focused on the following items during the design and operation phases:

1) *Design Phase*

- Modifications and improvements in HVDC CBs topologies, such as the type of components employed inside CBs, are highly required.
- The existing HVDC CBs configurations should be optimized, in terms of the minimum size of fundamental components, i.e., power switches, inductors, capacitors, MOVs, etc. while minimizing the cost of implementation and interruption time.
- Improvements in the performance of fast mechanical disconnecter considering low switching losses, fast operation, and high transient recovery voltage should be performed.
- Using high-performance semiconductor switches, such as wide band gap power devices, with low power losses should be well-studied.
- DC arc extinction modeling in order to properly understand the current interruption phenomenon and its effect on DC CB applications should be thoroughly investigated.
- Minimizing and interrupting the switching arcs considering their characteristics under various conditions for different CBs should be fully investigated.
- Modifications and improvements in fault current limiters and coordination with DC CBs are needed to be performed.
- Transient fault removal detection and HVDC CBs coordination to reconnect should be investigated.
- Simultaneous optimization schemes considering HVDC CBs and protection systems should be analyzed in-depth.

2) *Operation Phase*

There is a lack of HVDC CBs standards, including thresholds for acceptable power losses and operation speed. To establish a baseline for comparison purposes, a benchmark system for testing future HVDC CBs is vital. The testing of future HVDC CBs should follow the following steps:

- Proof-of-concept simulation studies using software models.
- Validation studies based on real-time digital simulators and Transient Network Analyzer (TNA) models.
- Prototype studies in the laboratory-based models utilizing Hardware-in-the-Loop (HIL) equipment connected to real-time digital simulators.
- Actual testing in real-world applications.

IX. CONCLUSIONS

This paper presents an exhaustive overview of High Voltage Direct Current (HVDC) Circuit Breaker (CB) considering different technologies/topologies presented in literature so far. For all HVDC CBs technologies/topologies, the main

characteristic(s) and possible applications are comparatively discussed. Moreover, several research gaps are identified regarding case studies and evaluation approaches. Finally, new research lines are recommended to improve the performance of existing HVDC CBs for different applications.

REFERENCES

- [1] F. Mohammadi, *et al.*, "A New Topology of a Fast Proactive Hybrid DC Circuit Breaker for MT-HVDC Grids," *Sustainability*, Vol.11(16), Aug. 2019.
- [2] F. Mohammadi, *et al.*, "An Improved Mixed AC/DC Power Flow Algorithm in Hybrid AC/DC Grids with MT-HVDC Systems," *Appl. Sci.*, Vol.10(1), Jan. 2020.
- [3] F. Mohammadi, *et al.*, "An Improved Droop-Based Control Strategy for MT-HVDC Systems," *Electronics*, Vol. 9(1), Jan. 2020.
- [4] P. Bucher, *et al.*, "Real-Time Simulation with An Industrial DCCB Controller in A HVDC Grid," *Electr. Power Syst. Res.*, Vol. 189, Dec. 2020.
- [5] M. K. Bucher, *et al.*, "Analytic Approximation of Fault Current Contributions From Capacitive Components in HVDC Cable Networks," *IEEE Trans. Power Deliv.*, Vol. 30(1), Feb. 2015.
- [6] A. Shukla, *et al.*, "A Survey on Hybrid Circuit-Breaker Topologies," *IEEE Trans. Power Deliv.*, Vol. 30(2), Apr. 2015.
- [7] A. Hassanpoor, *et al.*, "Technical Assessment of Load Commutation Switch in Hybrid HVDC Breaker," *IEEE Trans. Power Electron.*, Vol. 30(10), Oct. 2015.
- [8] A. Mokhberdorani, *et al.*, "Multiport Hybrid HVDC Circuit Breaker," *IEEE Trans. Ind. Electron.*, Vol. 65(1), Jan. 2018.
- [9] M. Amin, *et al.*, "Stability Analysis of Interconnected AC Power Systems with Multi-Terminal DC Grids Based on the Cigré DC Grid Test System," *3rd Renew. Power Gen.*, Sep. 2014.
- [10] S. Zhang, *et al.*, "Impact of DC Fault in Multi-Terminal DC Grid on Connected AC System Stability," *2017 IEEE Energy Conv. Cong. Expo.*, Oct. 2017.
- [11] N. A. Belda, *et al.*, "Test Circuits for HVDC Circuit Breakers," *IEEE Trans. Power Deliv.*, Vol. 32(1), Feb. 2017.
- [12] E. Kontos, *et al.*, "Impact of HVDC Transmission System Topology on Multiterminal DC Network Faults," *IEEE Trans. Power Deliv.*, Vol. 30(2), Apr. 2015.
- [13] J. Sneath, *et al.*, "Fault Detection and Interruption in An Earthed HVDC Grid Using ROCOV and Hybrid DC Breakers," *IEEE Trans. Power Deliv.*, Vol. 31(3), Jun. 2016.
- [14] N. Ahmed, *et al.*, "Efficient Modeling of An MMC-Based Multiterminal DC System Employing Hybrid HVDC Breakers," *IEEE Trans. Power Deliv.*, Vol. 30(4), Aug. 2015.
- [15] D. Jovicic, *et al.*, "Offshore DC Grids as An Interconnection of Radial Systems: Protection and Control Aspects," *IEEE Trans. Smart Grid*, Vol. 6(2), Mar. 2015.
- [16] O. Cwikowski, *et al.*, "Analysis and Simulation of the Proactive Hybrid Circuit Breaker," *IEEE 11th Intl. Conf. Power Electron. Drive Syst.*, Jun. 2015.
- [17] Y. Wang, *et al.*, "Future HVDC-Grids Employing Modular Multilevel Converters and Hybrid DC-Breakers," *15th Eur. Conf. Power Electron. App.*, Sep. 2013.
- [18] Y. Wang, *et al.*, "A Fast Switching, Scalable DC-Breaker for Meshed HVDC-SuperGrids," *Intl. Exhib. Conf. for Power Electron., Intell. Motion, Renew. Energy and Energy Mngmt.*, May 2014.
- [19] F. Mohammadi, *et al.*, "A Fast Fault Detection and Identification Approach in Power Distribution Systems," *IEEE 5th Intl. Conf. Power Gen. Syst. Renew. Energy Tech.*, Aug. 2019.
- [20] F. Mohammadi, *et al.*, "Stability Analysis of Electric Power System," *4th National Conf. Tech. in Elec. Comp. Eng.*, Dec. 2018.
- [21] J. Häfner, *et al.*, "Proactive Hybrid HVDC Breakers—A Key Innovation for Reliable HVDC Grids," *CIGRÉ Intl. Symp.: Electric Power System of the Future—Integrating Supergrids and Microgrids*, Sep. 2011.
- [22] A. Mokhberdorani, *et al.*, "A New Topology of Fast Solid-State HVDC Circuit Breaker for Offshore Wind Integration Applications," *17th Eur. Conf. Power Electron. App.*, Sep. 2015.
- [23] W. Lin, *et al.*, "Modelling of High-Power Hybrid DC Circuit Breaker for Grid-Level Studies," *IET Power Electron.*, Vol. 9(2), Feb. 2016.
- [24] G. Liu, *et al.*, "Assembly HVDC Breaker for HVDC Grids with Modular Multilevel Converters," *IEEE Trans. Power Electron.*, Vol. 32(2), Feb. 2017.

- [25] L. Feng, *et al.*, "A 320kV Hybrid HVDC Circuit Breaker Based on Thyristors Forced Current Zero Technique," *IEEE Appl. Power Electron. Conf. Expo.*, Mar. 2017.
- [26] H. Radmanesh, *et al.*, "A Novel Solid-State Fault Current-Limiting Circuit Breaker for Medium-Voltage Network Applications," *Power Deliv.*, Vol. 31(1), Feb. 2016.
- [27] M. Abedrabbo, *et al.*, "Systematic Approach to HVDC Circuit Breaker Sizing," *IEEE Trans. Power Deliv.*, Vol. 35(1), Feb. 2020.
- [28] O. Cwikowski, *et al.*, "Operating DC Circuit Breakers with MMC," *IEEE Trans. Power Deliv.*, Vol. 33(1), Feb. 2018.
- [29] M. Bröker, *et al.*, "Testing Metal-Oxide Varistors for HVDC Breaker Application," *IEEE Trans. Power Deliv.*, Vol. 34(1), Feb. 2019.
- [30] X. Liao, *et al.*, "Voltage Overshoot Suppression for SiC MOSFET-Based DC Solid-State Circuit Breaker," *IEEE Trans. Compon. Packaging Manuf. Technol.*, Vol. 9(7), Apr. 2019.
- [31] A. Mokhberdoran, *et al.*, "A Review on HVDC Circuit Breakers," *3<sup>rd</sup> Ren. Power Gen. Conf.*, Sep. 2014.
- [32] Q. Guo, *et al.*, "Novel Topology of DC Circuit Breaker and Current Interruption in HVDC Networks," *IEEE Trans. Elec. Electron. Eng.*, Vol. 12(4), Jul. 2017.
- [33] M. K. Bucher, *et al.*, "Fault Current Interruption in Multiterminal HVDC Networks," *IEEE Trans. Power Deliv.*, Vol. 31(1), Feb. 2016.
- [34] T. Eriksson, *et al.*, "A Low Loss Mechanical HVDC Breaker for HVDC Grid Applications," *CIGRE Session*, Aug. 2016.
- [35] D. Jovcic, *et al.*, "Adopting Circuit Breakers for High-Voltage DC Networks: Appropriating the Vast Advantages of DC Transmission Grids," *IEEE PES Mag.*, Vol. 17(3), May-Jun. 2019.
- [36] M. Heidemann, *et al.*, "A Systematic Study on Fault Currents in Multiterminal HVDC Grids," *CIGRE Lund Symp. 2015 - Aer. Bdr. - HVDC Syst. Mkt. Integ.*, May 2015.
- [37] W. Xiang, *et al.*, "Research on Fast Solid State DC Breaker Based on a Natural Current Zero-Crossing Point," *J. Mod. Power Syst. Clean Energy.*, Vol. 2(1), Mar. 2014.
- [38] D. Andersson, "Current Instability and Chopping with Arcs in Series," *IEE Proceedings C - Gen., Trans. Dist.*, Vol. 132(4), Jul. 1985.
- [39] S. Tokoyoda, *et al.*, "High Frequency Interruption Characteristics of VCB and Its Application to High Voltage DC Circuit Breaker," *3<sup>rd</sup> Intl. Conf. Elec. Power Eqpt. - Switch. Tech.*, Oct. 2015.
- [40] K. A. Corzine, "A New-Coupled-Inductor Circuit Breaker for DC Applications," *IEEE Trans. Power Electron.*, Vol. 32(2), Feb. 2017.
- [41] D. Keshavarzi, *et al.*, "A Z-Source-Based Bidirectional DC Circuit Breaker with Fault Current Limitation and Interruption Capabilities," *IEEE Trans. Power Electron.*, Vol. 32(9), Sep. 2017.
- [42] A. Maqsood, *et al.*, "Modified Z-Source DC Circuit Breaker Topologies," *IEEE Trans. Power Electron.*, Vol. 31(10), Oct. 2016.
- [43] D. Jovcic, *et al.*, "Fast Fault Current Interruption on High-Power DC Networks," *IEEE PES General Mtg.*, Jul. 2010.
- [44] C. Meyer, *et al.*, "Circuit Breaker Concepts for Future High-Power DC-Applications," *14<sup>th</sup> IAS Annu. Mtg. Conf. Rec. of the 2005 Ind. App. Conf.*, Oct. 2005.
- [45] P. Van Gelder, *et al.*, "Zero Volt Switching Hybrid DC Circuit Breakers," *Conf. Rec. of the 2000 IEEE Ind. App. Conf. 35<sup>th</sup> IAS Annu. Mtg. World Conf. Ind. App. of Elec. Energy (Cat. No.00CH37129)*, Oct. 2000.
- [46] D. Bösche, *et al.*, "Breaking Performance Investigation of Hybrid DC Circuit Breakers: An Experimental Approach," *IEEE 61<sup>st</sup> Holm Conf. Elec. Con.*, Oct. 2015.
- [47] D. Bösche, *et al.*, "Hybrid DC Circuit Breaker Feasibility Study," *IEEE Trans. Compon. Packaging Manuf. Technol.*, Vol. 7(3), Mar. 2017.
- [48] M. Callavik, *et al.*, "The Hybrid HVDC Breaker, An Innovation Break-through Enabling Reliable HVDC Grids," *ABB Grid Syst., Technical Paper*, Nov. 2012.
- [49] A. N. Greenwood, *et al.*, "Theory and Application of the Commutation Principle for HVDC Circuit Breakers," *IEEE Trans. Power Appar. Syst.*, Vol. PAS-91(4), Jul. 1972.
- [50] H. A. Darwish, *et al.*, "Enhanced Commutation Circuit Design of HVDC Circuit Breaker Using EMTP," *2005/2006 IEEE/PES Trans. Dist. Conf. Exhib.*, May 2006.
- [51] H. Brumshagen, *et al.*, "New Developments in Design and Testing of HVDC Circuit Breakers," *IEEE Trans. Power Appar. Syst.*, Vol. PAS-93(5), Sep. 1974.
- [52] G. A. Hofmann, *et al.*, "A High Speed HVDC Circuit Breaker with Crossed-Field Interrupters," *IEEE Trans. Power Appar. Syst.*, Vol. 95(4), Jul. 1976.
- [53] G. A. Hofmann, *et al.*, "Field Test of HVDC Circuit Breaker: Load Break and Fault Clearing on the Pacific Intertie," *IEEE Trans. Power Appar. Syst.*, Vol. 95(3), May 1976.
- [54] D. J. Melvold, *et al.*, "Three Terminal Operation of the Pacific HVDC Intertie for DC Circuit Breaker Testing," *IEEE Trans. Power Appar. Syst.*, Vol. 95(4), Jul. 1976.
- [55] B. L. Damsky, *et al.*, "A New HVDC Circuit Breaker System Design For  $\pm 400$  kV," *7<sup>th</sup> IEEE/PES Trans. Dist. Conf. Expo.*, Apr. 1979.
- [56] S. Yanabu, *et al.*, "Development of HVDC Circuit Breaker and its Interrupting Test," *IEEE Trans. Power Appar. Syst.*, Vol. PAS-101(7), Jul. 1982.
- [57] T. Senda, *et al.*, "Development of HVDC Circuit Breaker Based on Hybrid Interruption Scheme," *IEEE Trans. Power Appar. Syst.*, Vol. PAS-103(3), Mar. 1984.
- [58] S. Yanabu, *et al.*, "Development of HVDC Circuit Breaker and Its Interrupting Test," *IEEE Power Eng. Rev.*, Vol. PER-2(7), Jul. 1982.
- [59] D. Alferov, *et al.*, "DC Vacuum Circuit-Breaker," *23<sup>rd</sup> Intl. Symp. Disch. Elec. Insuln. in Vac.*, Sep. 2008.
- [60] K. Arimatsu, *et al.*, "Development and Interrupting Tests on 250KV 8KA HVDC Circuit Breaker," *IEEE Trans. Power Appar. Syst.*, Vol. PAS-104(9), Sep. 1985.
- [61] B. Bachmann, *et al.*, "Development of a 500kV Airblast HVDC Circuit Breaker," *IEEE Trans. Power Appar. Syst.*, Vol. PAS-104(9), Sep. 1985.
- [62] B. Pauli, *et al.*, "Development of a High Current HVDC Circuit Breaker with Fast Fault Clearing Capability," *IEEE Trans. Power Deliv.*, Vol. 3(4), Oct. 1988.
- [63] A. Lee, *et al.*, "The Development of a HVDC SF6 Breaker," *IEEE Trans. Power Appar. Syst.*, Vol. PAS-104(10), Oct. 1985.
- [64] R. Jungblut, *et al.*, "Hybrid High-Speed DC Circuit Breaker Using Charge-Storage Diode," *Conf. Record of the 1998 IEEE Ind. Comm. Power Syst. Technical Conf. (Cat. No.98CH36202)*, May 1998.
- [65] Z. Q. Shi, *et al.*, "Design and Numerical Investigation of A HVDC Vacuum Switch Based on Artificial Current Zero," *IEEE Trans. Dielectr. Electr. Insul.*, Vol. 22(1), Feb. 2015.
- [66] G. Ge, *et al.*, "HVDC Hybrid Circuit Breaker Based on SF6 Interrupter and Vacuum Interrupter in Series," *2<sup>nd</sup> Intl. Conf. Elec. Power Eqpt. - Switch. Tech.*, Oct. 2013.
- [67] W. Lin, *et al.*, "Modelling of High Power Mechanical DC Circuit Breaker," *IEEE PES Asia-Pac. Power and Energy Eng. Conf.*, Nov. 2015.
- [68] M. Bonkarev, *et al.*, "Simulation-Based Performance Evaluation of Different Current Breaking Techniques Employed in Mechanical HVDC Circuit Breakers," *IEEE Intl. Conf. High Voltage Eng. App.*, Sep. 2016.
- [69] Y. Shan, *et al.*, "Successful Fault Current Interruption on DC Circuit Breaker," *IET Power Electron.*, Vol. 9(2), Feb. 2016.
- [70] L. Ångquist, *et al.*, "A New DC Breaker with Reduced Need for Semiconductors," *18<sup>th</sup> Eur. Conf. Power Electron. App.*, Sep. 2016.
- [71] L. Ångquist, *et al.*, "Fast HVDC Breaker Using Reduced-Rating Power Electronics," *13<sup>th</sup> IET Intl. Conf. AC DC Power Trans.*, Feb. 2017.
- [72] L. Li, *et al.*, "Nonlinear Frequency Characteristic of Multiple Series Gaps with Voltage-Dividing Network and Its Application in HVDC Circuit Breaker," *IEEE Trans. Plasma Sci.*, Vol. 44(10), Oct. 2016.
- [73] L. Liu, *et al.*, "The DC Circuit Breaker with Necessary Bidirectional Interruption Capability," *IEEE PES Asia-Pac. Power and Energy Eng. Conf.*, Oct. 2016.
- [74] K. Tahata, *et al.*, "HVDC Circuit Breakers for HVDC Grid Applications," *11<sup>th</sup> IET Intl. Conf. AC DC Power Trans.*, Feb. 2015.
- [75] T. Schultz, *et al.*, "Circuit Breakers for Fault Current Interruption in HVDC Grids," *VDE High Voltage Tech. 2016: ETG-Symp.*, Nov. 2016.
- [76] N. Xia, *et al.*, "Investigations on the Safe Stroke of Mechanical HVDC Vacuum Circuit Breaker," *The J of Eng.*, Vol. 2019(16), Mar. 2019.
- [77] W. Wen, *et al.*, "Transient Current Interruption Characteristics of a Novel Mechanical DC Circuit Breaker," *IEEE Trans. Power Electron.*, Vol. 33(11), Nov. 2018.
- [78] S.-Y. Park, *et al.*, "Design and Implementation of Arc-Induction Type DC Circuit Breaker Confirming Prototype Model," *IEEE Trans. Appl. Supercond.*, Vol. 30(4), Jun. 2020.
- [79] A. Suzuki, *et al.*, "HVDC Circuit Breakers Combining Mechanical Switches and a Multilevel PWM Converter: Verification by Downscaled Models," *IEEE Trans. Power Electron.*, Vol. 34(5), May 2019.
- [80] R. Rodrigues, *et al.*, "A Review of Solid-State Circuit Breakers," *IEEE Trans. Power Electron.*, Vol. 36(1), Jan. 2021.
- [81] M. Kempkes, *et al.*, "Solid-State Circuit Breakers for Medium Voltage DC Power," *2011 IEEE Elec. Ship Tech. Symp.*, Apr. 2011.
- [82] H.-J. Jang, *et al.*, "A Configuration Concept of Solid State Switch for 2kV Class DC Circuit Breaker," *3<sup>rd</sup> Intl. Conf. Elec. Power Eqpt. - Switch. Tech.*, Oct. 2015.
- [83] C. M. Franck, "HVDC Circuit Breakers: A Review Identifying Future Research Needs," *IEEE Trans. Power Deliv.*, Vol. 26(2), Apr. 2011.

- [84] K. Sano, *et al.*, "A Surgeless Solid-State DC Circuit Breaker for Voltage-Source-Converter-Based HVDC Systems," *IEEE Trans. Ind. Appl.*, Vol. 50(4), Jul.-Aug. 2014.
- [85] L. Feng, *et al.*, "Development of a 10kV Solid-State DC Circuit Breaker Based on Press-Pack IGBT for VSC-HVDC System," *IEEE 8<sup>th</sup> Intl. Power Electron. Motion Cont. Conf.*, May 2016.
- [86] F. Zhang, *et al.*, "Voltage Balancing Optimization of Series-Connected IGBTs in Solid-State Breaker by Using Driving Signal Adjustment Technique," *IEEE 2<sup>nd</sup> Intl. Fut. Energy Electron. Conf.*, Nov. 2015.
- [87] H. Li, *et al.*, "Solid State DC Circuit Breaker for Super Uninterruptible Power Supply," *2014 Intl. Power Electron. App. Conf. Expo.*, Nov. 2014.
- [88] S. Negari, *et al.*, "A New Solid-State HVDC Circuit Breaker Topology for Offshore Wind Farms," *IEEE 5<sup>th</sup> Intl. Symp. Power Electron. for Distrib. Gen. Syst.*, Jun. 2014.
- [89] L. Qi, *et al.*, "Solid-State Circuit Breaker Protection for DC Shipboard Power Systems: Breaker Design, Protection Scheme, Validation Testing," *IEEE Trans. Ind. Appl.*, Vol. 56(2), Mar.-Apr. 2020.
- [90] J.-Y. Kim, *et al.*, "New DC Solid State Circuit Breaker with Reclosing and Rebreaking Capabilities," *IEEE 8<sup>th</sup> Intl. Power Electron. Motion Cont. Conf.*, May 2016.
- [91] J. Mu, *et al.*, "Analysis and Design of Topological Structure for DC Solid-State Circuit Breaker," *2009 World Non-Grid-Connected Wind Power and Energy Conf.*, Sep. 2009.
- [92] F. Z. Peng, "Z-Source Inverter," *IEEE Trans. Ind. Appl.*, Vol. 39(2), Mar.-Apr. 2003.
- [93] K. A. Corzine, *et al.*, "A New Z-Source DC Circuit Breaker," *IEEE Trans. Power Electron.*, Vol. 27(6), Jun. 2012.
- [94] K. A. Corzine, *et al.*, "Structure and Analysis of the Z-Source MVDC Breaker," *2011 IEEE Elec. Ship Tech. Symp.*, Apr. 2011.
- [95] P. Prempraneerach, *et al.*, "Optimization of a Z-Source DC Circuit Breaker," *2013 IEEE Elec. Ship Tech. Symp.*, Apr. 2013.
- [96] A. Overstreet, *et al.*, "Modified Z-Source DC Circuit Breaker Topologies," *2014 Clemson Univ. Power Syst. Conf.*, Mar. 2014.
- [97] A. H. Chang, *et al.*, "Analysis and Design of DC System Protection Using Z-Source Circuit Breaker," *IEEE Trans. Power Electron.*, Vol. 31(2), Feb. 2016.
- [98] S. G. Savaliya, *et al.*, "Analysis and Experimental Validation of Bidirectional Z-Source DC Circuit Breakers," *IEEE Trans. Ind. Electron.*, Vol. 67(6), Jun. 2020.
- [99] L. Mackey, *et al.*, "Optimization and Control of a Z-Source, Ultrafast Mechanically Switched, High-Efficiency DC Circuit Breaker," *IEEE Trans. Ind. Appl.*, Vol. 56(3), May-Jun. 2020.
- [100] D. J. Ryan, *et al.*, "A Bidirectional Series Z-Source Circuit Breaker," *IEEE Trans. Power Electron.*, Vol. 33(9), Sep. 2018.
- [101] J. Shu, *et al.*, "An Active Z-Source DC Circuit Breaker Combined with SCR and IGBT," *IEEE Trans. Power Electron.*, Vol. 35(10), Oct. 2020.
- [102] A. Hassanpoor, *et al.*, "Cost-Effective Solutions for Handling DC Faults in VSC HVDC Transmission," *18<sup>th</sup> Eur. Conf. Power Electron. App.*, Sep. 2016.
- [103] A. Bindra, "Wide-Bandgap-Based Power Devices: Reshaping the Power Electronics Landscape," *IEEE Power Electron. Mag.*, Vol. 2(1), Mar. 2015.
- [104] D. P. Urciuoli, *et al.*, "A Compact 100-A, 850-V, Silicon Carbide Solid-State DC Circuit Breaker," *2016 IEEE Energy Conv. Cong. Expo.*, Sep. 2016.
- [105] X. Song, *et al.*, "Theoretical and Experimental Study of 22 kV SiC Emitter Turn-OFF (ETO) Thyristor," *IEEE Trans. Power Electron.*, Vol. 32(8), Aug. 2017.
- [106] Y. Zhang, *et al.*, "Over-Current Protection Scheme for SiC Power MOSFET DC Circuit Breaker," *2014 IEEE Energy Conv. Cong. Expo.*, Sep. 2014.
- [107] Z. Miao, *et al.*, "A Self-Powered Bidirectional DC Solid State Circuit Breaker Using Two Normally-On SiC JFETs," *2015 IEEE Energy Conv. Cong. Expo.*, Sep. 2015.
- [108] D. He, *et al.*, "A SiC JFET-Based Solid State Circuit Breaker with Digitally Controlled Current-Time Profiles," *IEEE Trans. Emerg. Sel. Topics Power Electron.*, Vol. 7(3), Sep. 2019.
- [109] D. Jovic, *et al.*, "Developing DC Transmission Networks Using DC Transformers," *IEEE Trans. Power Deliv.*, Vol. 25(4), Oct. 2010.
- [110] M. J. Carrizosa, *et al.*, "DC / DC Converters as DC Circuit-Breakers in HVDC Networks Operation," *16<sup>th</sup> Eur. Conf. Power Electron. App.*, Aug. 2014.
- [111] P. Cairoli, *et al.*, "Coordinated Control of the Bus Tie Switches and Power Supply Converters for Fault Protection in DC Microgrids," *IEEE Trans. Power Electron.*, Vol. 28(4), Apr. 2013.
- [112] L. Tang, *et al.*, "Fast Acting DC Circuit Breaker for HVDC Transmission Line Based on DC/DC Chopper," *2014 Intl. Power Electron. Conf.*, May 2014.
- [113] R. L. Sellick, *et al.*, "A High-Speed HVDC Breaker Topology with Integral Voltage-Changing Capability," *2015 IEEE Elec. Insuln. Conf.*, Jun. 2015.
- [114] D. Jovic, *et al.*, "Multiport High-Power LCL DC Hub for Use in DC Transmission Grids," *IEEE Trans. Power Deliv.*, Vol. 29(2), Apr. 2014.
- [115] Y. Liu, *et al.*, "Topological Analysis of HVDC Circuit Breaker with Coupling Transformer," *2015 IEEE 1<sup>st</sup> Intl. Conf. DC Microgrids*, Jun. 2015.
- [116] A. Maqsood, *et al.*, "Z-Source DC Circuit Breakers with Coupled Inductors," *2015 IEEE Energy Conv. Cong. Expo.*, Sep. 2015.
- [117] J. Magnusson, *et al.*, "Design Aspects of A Medium Voltage Hybrid DC Breaker," *IEEE PES Innov. Smart Grid Tech.*, Oct. 2014.
- [118] K. Yasuoka, *et al.*, "A Hybrid DC Circuit Breaker with Vacuum Contact and SiC-MOSFET for Arcless Commutation," *IEEE 62<sup>nd</sup> Holm Conf. Elec. Cont.*, Oct. 2016.
- [119] L. Novello, *et al.*, "Development and Testing of a 10-kA Hybrid Mechanical-Static DC Circuit Breaker," *IEEE Trans. Appl. Supercond.*, Vol. 21(6), Dec. 2011.
- [120] Z. Chen, *et al.*, "Analysis and Experiments for IGBT, IEGT, and IGCT in Hybrid DC Circuit Breaker," *IEEE Trans. Ind. Electron.*, Vol. 65(4), Apr. 2018.
- [121] M. Rahimo, *et al.*, "The Bimode Insulated Gate Transistor (BIGT), An Ideal Power Semiconductor for Power Electronics Based DC Breaker Applications," *CIGRE Session*, Apr. 2014.
- [122] A. Ray, *et al.*, "Coupled Inductor-Based Zero Current Switching Hybrid DC Circuit Breaker Topologies," *IEEE Trans. Ind. Appl.*, Vol. 55(5), Sep.-Oct. 2019.
- [123] C. Peng, *et al.*, "Current Commutation in a Medium Voltage Hybrid DC Circuit Breaker Using 15 kV Vacuum Switch and SiC Devices," *2015 IEEE Applied Power Electron. Conf. Expo.*, Mar. 2015.
- [124] D. Schmitt, *et al.*, "DC-Side Fault Current Management in Extended Multiterminal-HVDC-Grids," *Intl. Multi-Conf. Syst., Sig. and Dev.*, Mar. 2012.
- [125] M. Hajian, *et al.*, "Evaluation of Semiconductor Based Methods for Fault Isolation on High Voltage DC Grids," *IEEE Trans. Smart Grid*, Vol. 4(2), Jun. 2013.
- [126] A. Yanushkevich, *et al.*, "Switching Phenomena of HVDC Circuit Breaker in Multi-Terminal System," *11<sup>th</sup> IET Intl. Conf. AC DC Power Trans.*, Feb. 2015.
- [127] Y. Li, *et al.*, "DC Fault Protection of Multi-Terminal VSC-HVDC System with Hybrid DC Circuit Breaker," *2016 IEEE Energy Conv. Cong. Expo.*, Sep. 2016.
- [128] J. A. Martinez, *et al.*, "EMTP Modeling of Hybrid HVDC Breakers," *2015 IEEE PES General Mtg.*, Jul. 2015.
- [129] D. Pefitsis, *et al.*, "Design Considerations and Performance Evaluation of Hybrid DC Circuit Breakers for HVDC Grids," *18<sup>th</sup> Eur. Conf. Power Electron. App.*, Sep. 2016.
- [130] X. Su, *et al.*, "Modeling DC Circuit Breaker in MTDC for Wind Farms Based on Delay Slope Method," *42<sup>nd</sup> Annu. Conf. of IEEE Ind. Electron. Soc.*, Oct. 2016.
- [131] N. Lin, *et al.*, "Detailed Device-Level Electrothermal Modeling of the Proactive Hybrid HVDC Breaker for Real-Time Hardware-in-the-Loop Simulation of DC Grids," *IEEE Trans. Power Electron.*, Vol. 33(2), Feb. 2018.
- [132] F. B. Effah, *et al.*, "Hybrid HVDC Circuit Breaker with Self-Powered Gate Drives," *IET Power Electron.*, Vol. 9(2), Feb. 2016.
- [133] Y. Bingjian, *et al.*, "A Hybrid Circuit Breaker for DC-Application," *2015 IEEE 1<sup>st</sup> Intl. Conf. DC Microgrids*, Jun. 2015.
- [134] C. C. Davidson, *et al.*, "A New Ultra-Fast HVDC Circuit Breaker for Meshed DC Networks," *11<sup>th</sup> IET Intl. Conf. AC DC Power Trans.*, Feb. 2015.
- [135] R. Sander, *et al.*, "A Novel Current-Injection Based Design for HVDC Circuit Breakers," *Intl. Exhib. Conf. for Power Electron., Intell. Motion, Ren. Energy and Energy Mngmt.*, May 2015.
- [136] W. Zhou, *et al.*, "Development and Test of a 200kV Full-Bridge Based Hybrid HVDC Breaker," *17<sup>th</sup> Eur. Conf. Power Electron. App.*, Sep. 2015.
- [137] Y. Guo, *et al.*, "A Thyristor Full-Bridge-Based DC Circuit Breaker," *IEEE Trans. Power Electron.*, Vol. 35(1), Jan. 2020.
- [138] W. Wen, *et al.*, "Research on a Current Commutation Drive Circuit for Hybrid DC Circuit Breaker and Its Optimisation Design," *IET Gen., Trans. Dist.*, Vol. 10(3), Oct. 2016.
- [139] W. Wen, *et al.*, "Research on Current Commutation Measures for Hybrid DC Circuit Breakers," *IEEE Trans. Power Deliv.*, Vol. 31(4), Aug. 2016.

- [140] F. Xu, *et al.*, "Topology, Control and Fault Analysis of a New Type HVDC Breaker for HVDC Systems," *2016 IEEE PES Asia-Pac. Power and Energy Eng. Conf.*, Oct. 2016.
- [141] X. Song, *et al.*, "A Medium-Voltage Hybrid DC Circuit Breaker, Part I: Solid-State Main Breaker Based on 15 kV SiC Emitter Turn-OFF Thyristor," *IEEE Trans. Emerg. Sel. Topics Power Electron.*, Vol. 5(1), Mar. 2017.
- [142] S. Wang, *et al.*, "Bridge-Type Integrated Hybrid DC Circuit Breakers," *IEEE Trans. Emerg. Sel. Topics Power Electron.*, Vol. 8(2), Jun. 2020.
- [143] S. Li, *et al.*, "An Auxiliary DC Circuit Breaker Utilizing An Augmented MMC," *IEEE Trans. Power Deliv.*, Vol. 34(2), Apr. 2019.
- [144] J. Liu, *et al.*, "A Hybrid Current-Limiting Circuit for DC Line Fault in Multiterminal VSC-HVDC System," *IEEE Trans. Ind. Electron.*, Vol. 64(7), Jul. 2017.
- [145] S. Wang, *et al.*, "Conceptual Design of Bidirectional Hybrid DC Circuit Breaker for Quench Protection of the CFETR," *IEEE Trans. Appl. Supercond.*, Vol. 28(8), Dec. 2018.
- [146] A. Jamshidi Far, *et al.*, "Design, Modeling and Control of Hybrid DC Circuit Breaker Based on Fast Thyristors," *IEEE Trans. Power Deliv.*, Vol. 33(2), Apr. 2018.
- [147] M. Komatsu, "Approach and Basic Evaluation for the DC Circuit Breaker with Fault Current Limiting Feature," *2016 IEEE Intl. Telecom. Energy Conf.*, Oct. 2016.
- [148] C. Zhou, *et al.*, "The Application of Superconducting Fault Current Limiters in Manitoba Hydro HVDC System," *2013 IEEE PES General Mtg.*, Jul. 2013.
- [149] S. Roy, *et al.*, "Development of a Prototype Hybrid DC Circuit Breaker for Superconducting Magnets Quench Protection," *IEEE Trans. Appl. Supercond.*, Vol. 24(6), Dec. 2014.
- [150] S. Li, *et al.*, "A New Topology for Current-Limiting Solid-State HVDC Circuit Breaker," *IEEE 2<sup>nd</sup> Annu. Southern Power Electron. Conf.*, Dec. 2016.
- [151] S. Li, *et al.*, "Study on the Current Limiting Performance of a Novel SFCL in DC Systems," *IEEE Trans. Appl. Supercond.*, Vol. 27(4), Jun. 2017.
- [152] A. Heidary, *et al.*, "A Bridge-Type Fault Current Limiter and Hybrid Breaker for HVDC Grids Applications," *IET Gener. Transm. Distrib.*, Vol. 14(18), Sep. 2020.
- [153] A. Heidary, *et al.*, "Controllable Reactor Based Hybrid HVDC Breaker," *High Voltage*, Jun. 2020.
- [154] A. Heidary, *et al.*, "A DC-Reactor Based Solid-State Fault Current Limiter for HVDC Applications," *IEEE Trans. Power Deliv.*, Vol. 34(2), Apr. 2019.
- [155] S.-H. Lim, *et al.*, "Fault Current Limiting Characteristics of DC Dual Reactor Type SFCL Using Switching Operation of HTSC Elements," *IEEE Trans. Appl. Supercond.*, Vol. 16(2), Jun. 2006.
- [156] J. Shi, *et al.*, "The Application of Active Superconducting DC Fault Current Limiter in Hybrid AC/DC Power Supply Systems," *IEEE Trans. Appl. Supercond.*, Vol. 18(2), Jun. 2008.
- [157] Y. Chen, *et al.*, "Design and Application of a Superconducting Fault Current Limiter in DC Systems," *IEEE Trans. Appl. Supercond.*, Vol. 24(3), Jun. 2014.
- [158] C. Peng, *et al.*, "Potential Use of Fault Current Limiter in VSC Based DC Transmission Systems," *2012 Asia-Pac. Power and Energy Eng. Conf.*, Mar. 2012.
- [159] W. Ahmed, *et al.*, "DC Line Protection for VSC-HVDC System," *2012 IEEE Intl. Conf. Power Electron., Drives and Energy Syst.*, Dec. 2012.
- [160] J. Descloux, *et al.*, "Protection System for Meshed HVDC Network Using Superconducting Fault Current Limiters," *2013 IEEE Grenoble Conf.*, Jun. 2013.
- [161] F. A. Mourinho, *et al.*, "Modeling and Analysis of Superconducting Fault Current Limiters Applied in VSC-HVDC Systems," *2015 IEEE PES General Mtg.*, Jul. 2015.
- [162] B. Xiang, *et al.*, "DC-Current-Limiting Characteristics of YBCO Tapes for DC Currents of 50 A to 10 kA," *IEEE Trans. Appl. Supercond.*, Vol. 27(4), Jun. 2017.
- [163] B. Li, *et al.*, "Research on the Parameter Matching Between Active SI-SFCL and DC Circuit Breaker in DC Systems," *IEEE Trans. Appl. Supercond.*, Vol. 29(2), Mar. 2019.
- [164] S.-H. Hwang, *et al.*, "Characteristics of DC Circuit Breaker Applying Transformer-Type Superconducting Fault Current Limiter," *IEEE Trans. Appl. Supercond.*, Vol. 28(4), Jun. 2018.
- [165] K. Yang, *et al.*, "A Self-Charging Artificial Current Zero DC Circuit Breaker Based on Superconducting Fault Current Limiter," *IEEE Trans. Appl. Supercond.*, Vol. 29(2), Mar. 2019.
- [166] H.-C. Lin, *et al.*, "Integration of DC Circuit Breaker and Fault Current Limiter Based on Zero-Voltage Resonant Switching Approach," *IET Circ Devices Syst.*, Vol. 13, May 2019.
- [167] J.-G. Lee, *et al.*, "Impact of SFCL on the Four Types of HVDC Circuit Breakers by Simulation," *IEEE Trans. Appl. Supercond.*, Vol. 26(4), Jun. 2016.
- [168] B. Xiang, *et al.*, "A DC Circuit Breaker Based on Superconducting Current-Limiting Technology," *3<sup>rd</sup> Intl. Conf. Elec. Power Eqpt. - Switch. Tech.*, Oct. 2015.
- [169] X. Pei, *et al.*, "Superconducting Interface for a DC Circuit Breaker," *8<sup>th</sup> IET Intl. Conf. Power Elec., Mach. Drives*, Apr. 2016.
- [170] W. R. Leon Garcia, *et al.*, "Full-Selective Protection Strategy for MTDC Grids Based on R-Type Superconducting FCLs and Mechanical DC Circuit Breakers," *5<sup>th</sup> IET Intl. Conf. Ren. Power Gen.*, Sep. 2016.
- [171] U. Amir Khan, *et al.*, "A Novel Model of HVDC Hybrid-Type Superconducting Circuit Breaker and Its Performance Analysis for Limiting and Breaking DC Fault Currents," *IEEE Trans. Appl. Supercond.*, Vol. 25(6), Dec. 2015.
- [172] U. Amir Khan, *et al.*, "Feasibility Analysis of A Novel Hybrid-Type Superconducting Circuit Breaker in Multi-Terminal HVDC Networks," *Physica C: Superconductivity and its App.*, Vol. 518, Nov. 2015.
- [173] B. Chang, *et al.*, "Impact of Fault Current Limiter on VSC-HVDC DC Protection," *12<sup>th</sup> IET Intl. Conf. AC DC Power Trans.*, May 2016.
- [174] J. Xu, *et al.*, "Modular Reciprocating HVDC Circuit Breaker with Current-Limiting and Bi-Directional Series-Parallel Branch Switching Capability," *J. Mod. Power Syst. Clean Energy*, Vol. 8(4), Jul. 2020.
- [175] X. Pei, *et al.*, "Design and Experimental Tests of a Superconducting Hybrid DC Circuit Breaker," *IEEE Trans. Appl. Supercond.*, Vol. 28(3), Apr. 2018.
- [176] B. Xiang, *et al.*, "A CO<sub>2</sub>/O<sub>2</sub> Mixed Gas DC Circuit Breaker with Superconducting Fault Current-Limiting Technology," *IEEE Trans. Power Deliv.*, Vol. 35(4), Aug. 2020.
- [177] H. Rao, "Architecture of Nan'ao Multi-Terminal VSC-HVDC System and Its Multi-Functional Control," *CSEE J. Power Energy Syst.*, Vol. 1(4), Mar. 2015.
- [178] G. Tang, *et al.*, "Basic Topology and Key Devices of the Five-Terminal DC Grid," *CSEE J. Power Energy Syst.*, Vol. 1(2), Jun. 2015.
- [179] Z. Zhang, *et al.*, "Research and Development of 160 kV Ultra-Fast Mechanical HVDC Circuit Breaker," *Power Syst. Tech.*, Vol. 42(7), Jul. 2018.
- [180] H. Thakur, "HVDC Circuit Breaker: A Review on Challenges and Innovations," *Intl. J. of Elec. Eng. Tech.*, Vol. 6(9), Nov.-Dec. 2015.
- [181] Z. Jie, *et al.*, "Research of DC Circuit Breaker Applied on Zhoushan Multi-Terminal VSC-HVDC Project," *2016 IEEE PES Asia-Pac. Power and Energy Eng. Conf.*, Oct. 2016.
- [182] H. Pang, *et al.*, "Research on Key Technology and Equipment for Zhangbei 500kV DC Grid," *2018 Intl. Power Electron. Conf.*, May 2018.
- [183] Mohaddes-USP2015 D. Döring, *et al.*, "System Integration Aspects of DC Circuit Breakers," *IET Power Electron.*, Vol. 9(2), Feb. 2016.
- [184] M. Mohaddes Khorassani, "Hybrid DC Circuit Breaking Device," *U.S. Patent 2015/0022928A1*, Jan. 2015.