

By Tomasz Tarasiuk, Yuri Zunino,  
Maximiliano Bueno-López, Federico Silvestro,  
Andrzej Pilatis, and Marta Molinas

# Frequency Fluctuations in Marine Microgrids

Origins and identification tools.

**F**LUCTUATION OF FREQUENCY IS ARGUABLY the most characteristic feature of marine microgrids. This concerns both frequency drift during step load change and all quasi-periodic fluctuation due to the impact of various factors like generators' prime movers, the governor's characteristic, and sea conditions. This article aims to provide insight into the latter phenomena. Such quasi-periodic frequency fluctuations can have detrimental effects on electrical receivers' work, especially electric motors. For the study of these fluctuations, the use of time-frequency (TF) analysis methods is the most natural choice. Among TF analysis methods, the Hilbert-Huang transform (HHT) offers some advantages to analyze signals with multiple frequency components. It is well suited for nonlinear and nonstationary signals as it estimates the instantaneous frequency of the signal, which is defined

locally as the time derivative of the signal phase. The zoom discrete Fourier transform (zoom-DFT) is another method that can provide an instantaneous frequency representation of the signal using spectral zoom operation [usually a chirp z transform (CZT) method is used] and with that can portray quasi-periodic frequency fluctuations, should they exist. This article shows the ability of the HHT and the zoom-DFT in estimating the frequency fluctuations of the main frequency component of the microgrid voltage signals and of the various quasi-periodic components of the voltage signal. Finally, the current standard framework related to frequency changes in marine networks is presented, possible origins of the instantaneous frequency fluctuations are discussed, and tools for the phenomenon identification and related models are proposed. These considerations are based on the careful analysis of the behavior of three real marine systems onboard a research-training ship during the work of auxiliary generating sets, roll-on/roll-off (ro-ro)

<AU: Kindly check that ro-ro is spelled out correctly.>

Digital Object Identifier 10.1109/MELE.2020.3005698  
Date of current version: 2 September 2020

ship with mechanical propulsion and shaft generator as well as the integrated power system of the ship with electrical propulsion.

### Origins of Instantaneous Frequency Fluctuations on Shipboard

The maritime electric power systems belong to a class of isolated power systems called *microgrids*. The widely recognized issues with microgrids are power quality problems, such as harmonics, voltage fluctuations, and instantaneous frequency variations. These variations are a distinct feature of marine microgrids and will impact the operation of numerous receivers, particularly the electric motors. <AU: Please check whether the preceding edited sentence conveys the intended meaning.> To properly address this issue, origins, severity, and consequences of the instantaneous frequency fluctuations have to be properly recognized.

Generally, there are two major sources of instantaneous frequency fluctuations in maritime microgrids: pulsating torque of the generators' prime movers and load variations. The most commonly used prime movers for driving generators on shipboard are four-stroke medium-speed diesel engines. The output of such an engine is not constant but pulsating, with one positive peak and one negative peak (smaller one) of torque for every piston per 720° of crankshaft rotation. The positive peak can reach a value equal to several mean torque values. The frequency of this torque angular pulsation depends on the number of engine cylinders. To reduce the effect, additional inertia in the engine shaft is added in the form of a flywheel. Nevertheless, the pulsating torque of diesel engines has a detrimental effect on frequency in the maritime systems. The final result would depend on, among other things, mean rotational speed and the number of poles of the generator. As a result, instantaneous frequency modulation will be observed. The frequency of this modulation equals the actual power frequency divided by an integer.

The next source, namely frequent load variations in maritime microgrids, is a common feature of these systems. Usually they are attributed to fast demand changes as, e.g., during ship maneuvering. This results in significant voltage and frequency dips, which can be severe, but they have limited duration. The problem is commonly known and well recognized, so the ship classification societies established limits of voltage and frequency transient variations and recovery times. For instance, the permissible limit for frequency transient variation is  $\pm 10\%$  and recovery time is up to 5 s.

However, in maritime microgrids the load is constantly modulated as well because of the impact of environmental conditions like waves and wind. These phenomena lead to ship rolling and pitching, resulting, e.g., in the movement of fluids in tanks and fluctuation of pressures in fuel, cooling, and lubrication systems. <AU: Please

check whether the preceding edited sentence conveys the intended meaning.>

These usually small changes lead to minor instantaneous frequency variations. More important is the impact of waves and wind on the ship propeller force. Generally, harsh wave and wind conditions adversely impact the ship propulsion performance due to wake, thrust, and torque fluctuation in waves as well as possible increased resistance caused by wind. This will affect both mechanical and electrical propulsion of the ship. The latter leads to irregular (but quasi-periodic) electric propulsion load modulation. The characteristic of such a modulation generally depends on

- ▶ irregular wave characteristic (described by significant wave height and wave period; the irregular waves can be expressed as a sum of linear waves by linear superposition)
- ▶ ship speed
- ▶ ship course
- ▶ hull and propeller characteristic.

Finally, the resulting instantaneous frequency fluctuations depend on the interaction between both generation and load with varying instantaneous characteristics. The most important factors behind the fluctuations can be summarized as

- ▶ the characteristic of load modulation
- ▶ the diesel engine (generator's prime mover) governor type and settings
- ▶ the number of diesel engine cylinders and flywheel
- ▶ the generator and its automatic voltage regulators characteristics
- ▶ the number of generators working in parallel and mean load.

Nevertheless, the resulting instantaneous frequency fluctuation is a combination of components related to torque angular pulsation and components related to load modulation.

Finally, there is another reason for instantaneous frequency fluctuation in maritime microgrids: sometimes, to save fuel, the shaft generator is used. This means that the main engine used for ship propulsion also will be the prime mover of the generator. The changes of this engine rotational speed related to sea conditions obviously lead to fluctuations of the frequency on the shaft generator's terminal. To stabilize the frequency in the entire system, the energy is transferred via the power converter, with adverse impact on the system performance and the voltage waveform distortions. Sometimes the shaft generator is directly connected to the ship's main bus bars. However, this simple low-cost solution leads to instantaneous frequency fluctuation in waves comparable or even greater than in ships with electric propulsion.

### Standard Framework

The standards related to maritime microgrids usually do not concern the instantaneous frequency fluctuations, except for the previously mentioned transient variation.

The sole exception is the IEEE Standard 45 series. This phenomenon was mentioned in *IEEE Recommended Practice for Electrical Installations on Shipboard*, IEEE Standard 45, 2002, and *IEEE Recommended Practice for Electrical Installations on Shipboard-Design*, IEEE Standard 45.1, 2017. These standards define the frequency modulation as

The permitted periodic variation in frequency during normal operation that might be caused by regularly and randomly repeated loading. For the purpose of definition, the periodicity of frequency modulation should be considered to not exceed 10 s.

The severity of frequency modulation is calculated as the ratio of the difference between maximum and minimum instantaneous frequency and twice the nominal frequency expressed in percentage. The level of the frequency modulation is not to exceed 0.5%. Similarly, in *Lloyd's Register Rules and Regulations for the Classification of Ships 2019* it was stated there is to be "A maximum rate of change of frequency not exceeding  $\pm 1,5$  Hz per second during cyclic frequency fluctuations."

### Systems Under Research

For this article, three shipboard electrical power systems were selected. The systems represent the following three different classes of maritime microgrids:

- ▶ "classic" research-training ship with mechanical propulsion (Figure 1)
- ▶ ro-ro ship with mechanical propulsion and shaft generator working on main bus bar via gear (Figure 2)
- ▶ dynamic positioning of a ship with electrical propulsion (Figure 3)

The devices switched on during investigation are marked by green on each figure. For each investigated ship, the voltage samples were registered on main switchboards for two conditions: *calm* and *harsh sea*. For the first ship, the registrations were carried out in the North Sea during stormy conditions (sea condition approximately 8 B) and at Kattegat (sea condition approximately 2 B). <AU: Kindly spell out B.> For the second ship, the registration took place in the Baltic Sea during stormy conditions (sea condition approximately 6–7 B) and at Sund Strait (sea condition approximately 1–2 B). Finally, the third ship was investigated in the Baltic Sea during harsh sea conditions (sea condition approximately 5–6 B) and the Gdańsk Gulf (sea condition approximately 1–2 B).

The instantaneous frequency on each of the selected ships will be differently affected by sea conditions due to the various electric power system topologies. The common feature will be the existence of the component due to torque angular pulsation of the generator's prime mover.

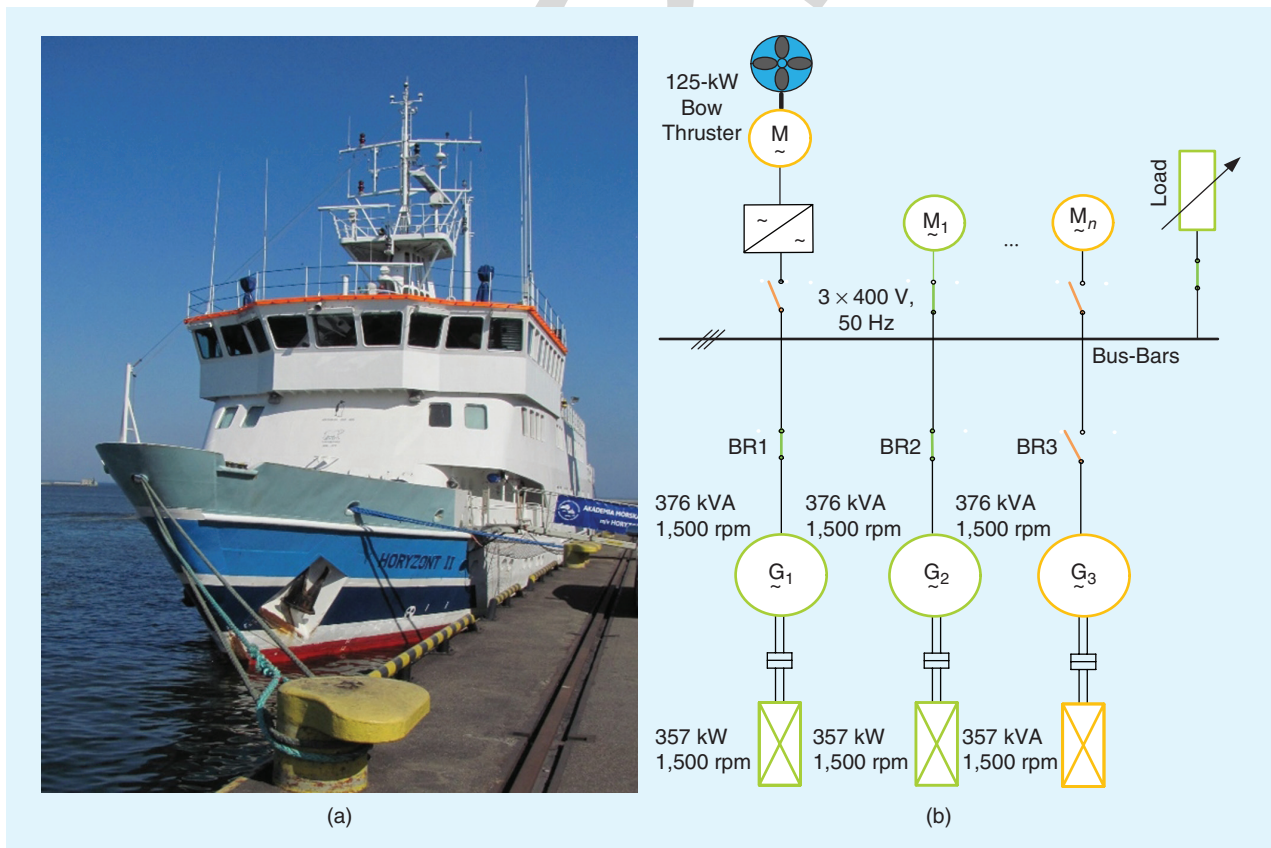

**Figure 1.** (a) A "classic" research-training ship with mechanical propulsion. (b) A simplified diagram of the electric power system of the ship with mechanical propulsion without shaft generator (the main engine is not presented in the figure). The generator prime movers are four-stroke diesel engines with 10 cylinders. <AU: Please confirm whether the edited caption text is acceptable and accurate. Also, kindly spell out M and G so that the definitions may be added to the caption.>

## Detection of Instantaneous Frequency for Marine Microgrid Applications

The empirical mode decomposition (EMD), part of the HHT, has been proposed as an adaptive TF data analysis method and combined with the Hilbert transform (HT) proved to be very useful for the detection of instantaneous frequency of the single components identified by the EMD decomposition. EMD has demonstrated its great advantages in different fields, and now we can show that it is possible to extend this application to marine microgrids. It does not require any restrictive assumption on the underlying model of the process/system under analysis, and it is able to handle both nonlinear and nonstationary signals. However, the algorithm has shown some limitations in identifying closely spaced spectral tones and components appearing intermittently in the signal, a phenomenon known as *mode mixing*.

The aim of the EMD method is to decompose the nonlinear and nonstationary signal  $y(t)$  into a sum of intrinsic mode functions (IMFs), which are independent oscillatory modes that satisfy two conditions: symmetric upper/lower envelopes (zero mean) and the numbers of zero-crossing and extrema that are either equal or differ by exactly one. Each IMF is projected into a complex plane through the HT. Therefore, the instantaneous frequency is defined as the time derivative of the IMF's vector in the complex plane:

$$\text{IMF}(t) = x(t) + j \text{IMF}(t) = a(t) e^{j\theta(t)} \xrightarrow{\text{HT}} f(t) = \frac{1}{2\pi} \frac{d\theta(t)}{dt}$$

Finally, a median filter has been implemented to more clearly compare the signals obtained through HHT with the zoom-DFT ones.

The second technique proposed in this article to identify the instantaneous frequency is the zoom-DFT. This method consists of the calculation of parts of the frequency spectrum around rated frequency with increased frequency resolution. The frequency bin with the highest value represents the actual instantaneous power frequency. Usually, a CZT is used for this purpose. For this research, the frequency resolution was assumed to be 0.001 Hz. The results of zoom-DFT calculations were refreshed every 1 ms, and the Kaiser window (parameter  $\beta = 7.65$ ) was used to suppress spectrum leakage from negative frequency fundamental component and harmonics. The window was dynamically synchronized (every 1 ms) to the momentary duration of three fundamental cycles. Because the great advantage of the HHT (Figure 4) **<AU: Kindly check whether the citation of Figure 4 is appropriate.>** is the opportunity to use only the information relevant to the application (Table 1), only the 50-Hz components will be considered in the following figures to make a fair comparison with the instantaneous frequency analysis obtained by the zoom-DFT technique (Figure 5). **<AU: Kindly check whether the citation of Figure 5 is appropriate.>**

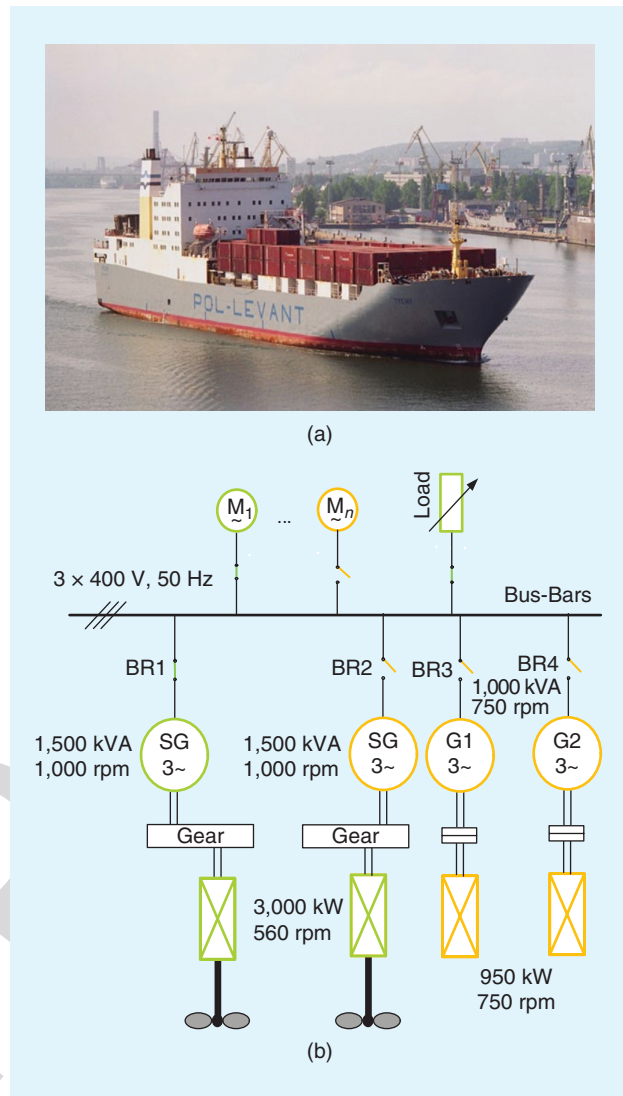

**Figure 2.** (a) A ro-ro ship with mechanical propulsion and a shaft generator working on main bus bar via gear. (b) A simplified diagram of the electric power system of the ship with mechanical propulsion and shaft generators. The main engines used for driving the generators are six-cylinder engines. **<AU: Please confirm whether the edited caption text is acceptable and accurate.>**

All of the results, except those from the research-training ship, show that there is a clear oscillation difference between the calm and rough sea conditions. In each case, it is possible to see the different oscillations of the instantaneous frequency, which confirm the hypothesis regarding the presence of instantaneous frequency fluctuations in marine microgrids. The difference between the results obtained through zoom-DFT and HHT can be attributed to the fact that the plots represent only the 50-Hz component in HHT analysis, whereas with the zoom-DFT, the plots represent the unique oscillatory frequency of the signal under analysis. **<AU: Please check whether the preceding edited sentence conveys the intended meaning.>**

The other components obtained by HHT (Table 1) show that the frequency components identified for each ship are the same for both calm and rough sea conditions but



(a)

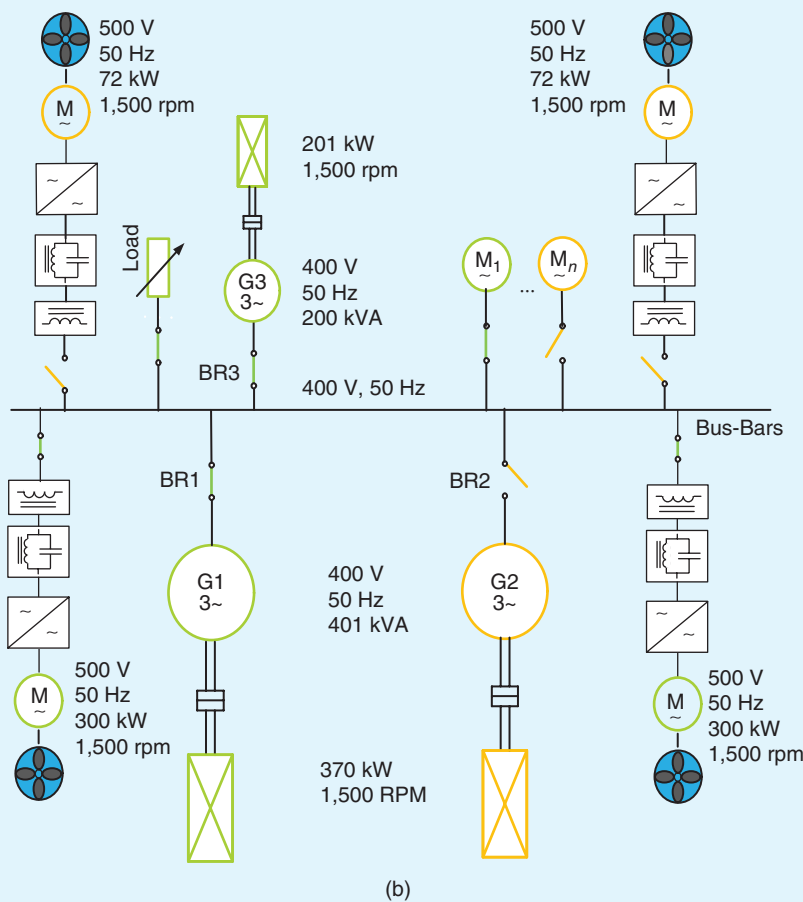

(b)

**Figure 3.** (a) The dynamic positioning of a ship with electrical propulsion. (b) A simplified diagram of the electric power system of the ship with electrical propulsion. The generators' prime movers are six-cylinder diesel engines. **<AU: Please confirm whether the edited caption text is acceptable and accurate.>**

with different amplitudes. However, there is no evident correlation between the peak amplitude of the individual components and the sea conditions. Nevertheless, all of the components identified are multiples of the 50-Hz frequency, and their origins can be associated with some of the causes discussed earlier in the article, such as pulsating torque characteristics, load modulation, and type of frequency converter of the propulsion system [active-front

end (AFE) for the dynamic positioning ship]. **<AU: Kindly check that DP is spelled out correctly>**

Regarding the research-training ship in Figure 1 (mechanical propulsion), two generators are operating in parallel with a 10-cylinder diesel engine as a prime mover. No shaft generators and frequency converters are present, which can indicate that the origins of the frequency components and the fluctuation of the 50-Hz frequency can be associated with the pulsating torque of the generators' prime movers. However, small instantaneous frequency fluctuation related to the impact of waves on ship auxiliary systems also is visible for the rough sea condition.

The ro-ro ship in Figure 2 (mechanical propulsion and shaft generator) has a six-cylinder engine connected to a shaft generator and there are no power converters. A large number of frequency components for this ship can be associated with the possible reflections of the sea conditions on the engine rotations and on the frequency on the shaft generator's terminal as well as the impact of gear between shaft generator and main engine, which is visible for a ro-ro ship with a 1,250-Hz component. Furthermore, in Figures 6 and 7, it is possible to see that the HHT and zoom-DFT results of the rough sea condition appear to be slightly phase shifted. This can be explained by the different phase properties of the two techniques. The strength of the HHT lies in its ability to preserve phase and amplitude while empirically separating signal from noise.

For the dynamic positioning ship in Figure 3 (electrical propulsion), two generators are operating

in parallel with a 10-cylinder diesel engine as a prime mover. Motors for dynamic positioning are connected to the bus through frequency converters with AFE and filters to accurately adjust the speed of the engines during the positioning operations. This is the case with less frequency components, and the presence of only the fifth harmonic in the signal can be attributed to the filters and the type of frequency converters used. The origins of the

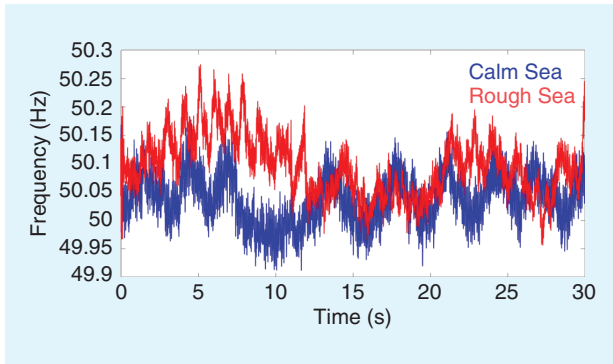

**Figure 4.** A research-training ship's instantaneous frequency (through HHT).

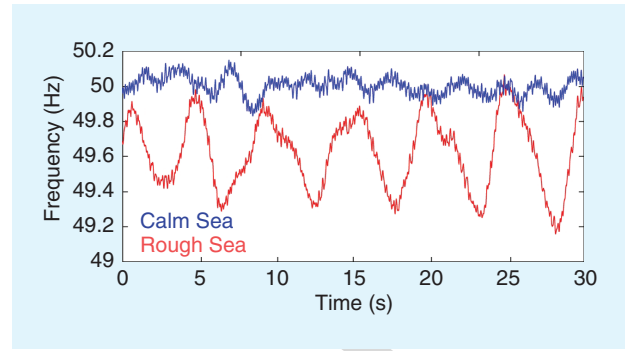

**Figure 7.** A ro-ro ship's instantaneous frequency (through zoom-DFT).

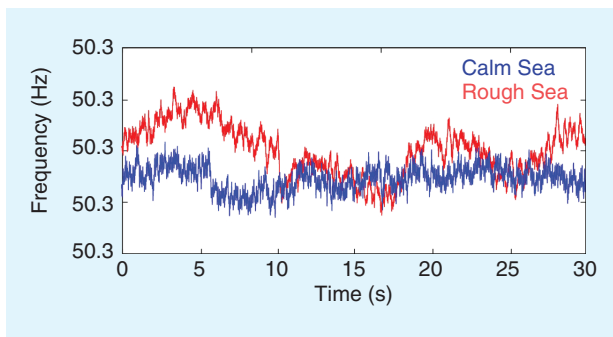

**Figure 5.** A research-training ship's instantaneous frequency (through zoom-DFT).

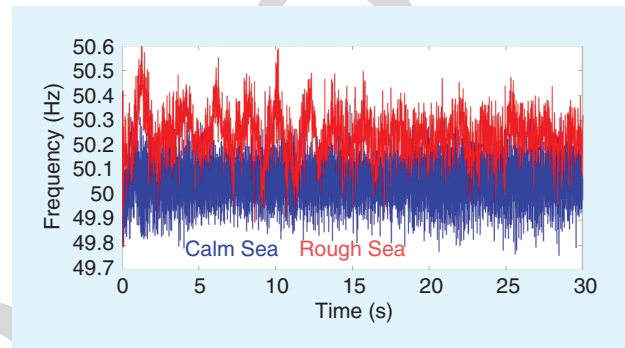

**Figure 8.** A dynamic positioning ship's instantaneous frequency (through HHT).

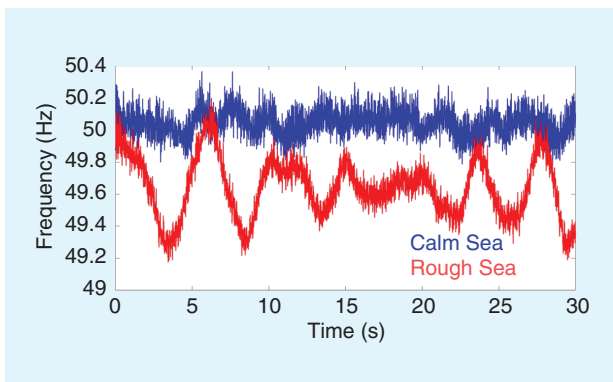

**Figure 6.** A ro-ro ship's instantaneous frequency (through HHT).

fluctuation of the 50-Hz frequency can be associated with the pulsating torque of the generators' prime movers for calm sea and waves for a rough sea condition (Figures 8 and 9). **<AU: Kindly check whether the citations of Figure 8 and 9 are appropriate.>** Analysis of the obtained results against the standard framework leads to the conclusion that only for the ro-ro ship during the rough sea condition is the level of frequency modulation beyond recommended permissible value laid in the IEEE standards (0.7% versus 0.5%). **<AU: Please check whether the preceding edited sentence conveys the intended meaning.>**

Finally, it must be stressed that both signal-processing techniques lead to similar results except for the rough sea

**TABLE 1. The frequency of the main components obtained through HHT.**

Ship	Sea Condition	Main Components' Frequency (Hz)	Peak Amplitude (% of the Fundamental)
Research-training (Figure 1)	Calm	550, 350, 50	1.59, 1.15, 100
	Rough	550, 350, 50	1.30, 2.29, 100
Ro-ro (Figure 2)	Calm	1,250, 650, 350, 250, 50	2.10, 4.63, 0.39, 0.97, 100
	Rough	1,250, 650, 350, 250, 50	2.11, 1.89, 0.45, 2.35, 100
Dynamic positioning (Figure 3)	Calm	250, 50	2.73, 100
	Rough	250, 50	9.01, 100

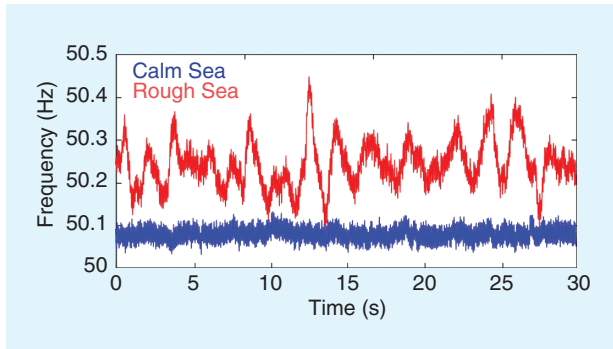

**Figure 9.** A dynamic positioning ship's instantaneous frequency (through zoom-DFT).

conditions for the ro-ro ship, and this enables us to reach the same conclusion regarding the considered systems behavior. With the exception of the ro-ro ship incongruence previously mentioned, the HHT seems to be suitable for these types of signals. Based on this statement and after the simulations conducted on the data to confirm the origins of the oscillations, the knowledge of the components found using the HHT will be useful to improve the power quality of the systems under analysis.

#### For Further Reading

O. B. Fosso and M. Molinas, "EMD mode mixing separation of signals with close spectral proximity in smart grids," in *Proc. 2018 IEEE PES Innovative Smart Grid Technologies Conf. Europe (ISGT-Europe)*, Sarajevo, pp. 1–6. doi: 10.1109/ISGTEurope.2018.8571816.

N. E. Huang et al., "The empirical mode decomposition and the hilbert spectrum for nonlinear and non-stationary time series analysis," *Proc. R. Soc. A, Math., Phys. Eng. Sci.*, vol. 454, no. 1971, pp. 903–995, 1998. doi: 10.1098/rspa.1998.0193.

<AU: Please confirm the inserted volume number, issue number, and page range are correct.>

T. Wang, "The segmented chirp Z-transform and its application in spectrum analysis," *IEEE Trans. Instrum. Meas.*, vol. 39, no. 2, pp. 318–323, Apr. 1990. doi: 10.1109/19.52508.

#### Biographies

**Tomasz Tarasiuk** (t.tarasiuk@we.umg.gdynia.pl) is with the Department of Marine Electrical Engineering, Gdynia Maritime University, Poland.

**Yuri Zunino** (yurizunino@gmail.com) is with the University of Genova, Italy.

**Maximiliano Bueno-López** (mbuenol@unicauca.edu.co) is with the Department of Electronic, Instrumentation and Control, Universidad del Cauca in Popayan, Colombia.

**Federico Silvestro** (federico.silvestro@unige.it) is with the Department of Electrical, Electronic, Telecommunication Engineering and Naval Architecture, University of Genova, Italy.

**Andrzej Pilatis** (a.pilat@we.umg.edu.pl) is with the Department of Marine Electrical Engineering, Gdynia Maritime University, Poland.

**Marta Molinas** (marta.molinas@ntnu.no) is with the Department of Engineering Cybernetics, The Norwegian University of Science and Technology, Trondheim, Norway.

***Fluctuation of frequency is arguably the most characteristic feature of marine microgrids.***

***The maritime electric power systems belong to a class of isolated power systems called microgrids.***

***The widely recognized issues with microgrids are power quality problems, such as harmonics, voltage fluctuations, and instantaneous frequency variations.***

***The severity of frequency modulation is calculated as the ratio of the difference between maximum and minimum instantaneous frequency and twice the nominal frequency expressed in percentage.***

***The instantaneous frequency on each of the selected ships will be differently affected by sea conditions due to the various electric power system topologies.***



***All of the results, except those from the research-training ship, show that there is a clear oscillation difference between the calm and rough sea conditions.***

***The strength of the HHT lies in its ability to preserve phase and amplitude while empirically separating signal from noise.***

IEEE PRO