



Norwegian University of
Science and Technology

MASTER THESIS

The Development of a Low-Cost Autonomous Pipe Leakage Sonar Device

Johan Christian Wigen Hjorth

February 2020

Norwegian University of Science and Technology (NTNU)

Department of Mechanical and Industrial Engineering (MTP)

Supervisor: Martin Steinert



Abstract

40 % of the 81 participating Norwegian municipalities lose more than 40 % of their freshwater to their water distribution network, according to Norsk Vann (2017). Only 50% of the studied network had a sufficient standard. Leakages may cause drops in pressure, which may release contaminants into the distribution network. Contaminated water can be dangerous and may cause sickness and even death. This is not sustainable in terms of health, environment or economy.

This master thesis aims to develop a new low-cost concept to locate water pipe leakages through the use of the Wayfaring Method within a framework of engineering design. Exploratory prototyping with rapid design iterations has been used to probe ideas with design-build-test cycles. In this way, knowledge gaps have been bridged, and emerging requirements for the solution have been defined.

From a pre-project where several ways of measuring distances underwater in low-cost manners were explored, a concept that could be applied in locating leakages emerged. The concept lets a passive sonar flow with the water stream in a pipe, and measures the distance traveled with a pinger positioned at a known point. With this concept, two key variables have been identified, which together determine the location of a leakage. These are the distance between the pinger and the sonar, and the sound pressure level (SPL) ambient to the sonar. Three subsystems of the prototype were designed, built, and tested concurrently to meet individual requirements set from the start, as well as emerging requirements. When the individual requirements were met, the subsystems were integrated into more relevant test environments.

The final prototype was tested to measure the two key variables successfully. Although the distance measurement was accurate and had a sufficient extrapolated range in an underwater environment, the results were not equal when tested in an actual pipe system. This unveiled not only insufficient knowledge of the problem space but also insufficient knowledge of how the integrated prototype interacts with its intended environment. Therefore, it is suggested that the product developer should early-on actively alternate testing the prototype integrated into the actual intended environment and prototyped test environments in future work. During the project, a paper concerning this experience was submitted to the NordDesign 2020 conference.

Based on the results of the project, the concept is considered feasible, with important unanswered questions. Furthermore, it is suggested a set of specific alterations on the prototype that may increase range, as well as other improvements that may add capabilities and increase the concept's application field. The outcome of this project is a prototype of a new low-cost solution with promising results, and a need for further development.

ACKNOWLEDGEMENTS

I would like to thank Martin Steinert for including me in the TrollLabs community, which have provided me with technical knowledge and generative questions, as well as the opportunity to nurture my ideas. I would also like to thank Norbit which have provided important technical help and Trondheim Vann og Avløp for giving me a firsthand experience of how pipe leakages are located and repaired today, as well as critical assistance in actual environment testing.

 CONTENTS

Abstract	ii
Preface	iv
Contents	vi
List of Figures	viii
1 Introduction, Background & Problem Statement	1
1.1 Approach: Wayfaring Method within an Engineering Design Framework . . .	1
1.2 Motivation - Status of Norwegian water distribution system today	2
1.3 Scope	3
1.4 Thesis structure	3
1.5 The water distribution network in Trondheim	3
1.6 How are water pipe leakages located today?	4
1.7 How is the leakage repair practice today?	5
1.8 Competing Innovative Solution	6
1.9 Problem Statement	6
1.10 Requirement by Trondheim Vann og Avløp	6
1.11 Research Questions	7
2 Theory	8
2.1 Sonar	8
2.2 Speed of sound	8
2.3 Frequencies and wavelength	8
2.4 Reflection	9
2.5 Absorption	10
2.6 Dissipation	11
2.7 Transducers	12
2.8 Transducer Analysis	14
2.9 Noise level	16
2.10 Range equation	16
3 Prototype	18
3.1 Concept Overview	18
3.2 Pinger	19
3.3 Sonar transducer	24
3.4 Sonar Electronics	27
3.5 Summary of the final prototype	34
4 Integration Testing and Results	35
4.1 Leakage detection	35
4.2 Distance measurement in pool	37

4.3	Distance measurement in actual pipe-network environment	41
4.4	Summary of Integration Testing and Results	44
5	Paper submitted to the NordDesign 2020 Conference	45
5.1	The Submitted Paper	45
6	Discussion and Future Work	56
6.1	Results	56
6.2	Potential Error Sources	56
6.3	Emerging requirement and key insights	58
6.4	Concept	59
6.5	Method	60
6.6	Summary of Method	62
6.7	Future Work	62
7	Conclusion	66
	Bibliography	67
	Appendix A The Recording Script of The Sonar	69
	Appendix B Post-processing Script of Recorded Data in Matlab	71
	Appendix C Project Thesis, Johan Hjorth	73
	Appendix D Risk Assesment for Metallography Lab	137

LIST OF FIGURES

1.1	The Hunter-Gatherer Model Steinert & Leifer (2012)	1
1.2	A Trondheim Vann og Avløp professional listening for leakages	4
1.3	A Typical Leak	5
2.1	Transmission and reflection of an incident wave on a normal boundary	9
2.2	Acoustic material data on common materials from Regtien & Dertien (2018)	10
2.3	Illustration of wave dissipation	11
2.4	The pinger-transducer provided by Norbit.	12
2.5	Impedance of the pinger-transducer.	13
2.6	The sonar-transducer.	14
2.7	Impedance of the pinger-transducer.	14
2.8	The sonar-transducer.	15
2.9	The noise level in the pool test.	16
3.1	Working principle of the concept	18
3.2	Pinger working principle	19
3.3	The oscilloscope for Pulse Generation: the Analog Discovery 2 board	20
3.4	The oscilloscope interface while armed to generate pulse when triggered	21
3.5	The car-amplifier used to amplify the pulse	22
3.6	One of the GPS-units connected to antenna.	22
3.7	The final mechanical structure of the pinger.	23
3.8	A typical armature that connects pipes in manholes. The picture is provided by Trondheim Vann og Avløp.	24
3.9	The sonar-transducer in the making process.	25
3.10	The mobile transducer with a epoxy layer and water tight lid.	26
3.11	Sonar working principal	27
3.12	Sketch of the pre-amplification card circuit.	29
3.13	The pre-amplification card circuit.	30
3.14	The two sound cards used for testing. Xtrfy SC1 at the bottom, and the USB-MA from Andrea Communications with altered form factor at the bottom.	31
3.15	The Raspberry Pi 3 Model A+ was used as the on-board computer.	32
3.16	The battery used to power the sensor package with power.	33
4.1	A recording with no simulated leakages in Matlab Signal Analyzer.	35
4.2	Plot of recording of simulated leakage at 156.3 m in Matlab Signal Analyzer.	36
4.3	Plot of recorded simulated leakage at 0.5 m.	36
4.4	Recorded simulation at 0.5 m, in Matlab Signal Analyzer.	37
4.5	Recording from distance measurement test at 8.55 m with a V_{out} of 2V.	38
4.6	Section of recording from distance measurement test at 8.55 m with a V_{out} of 2V.	39
4.7	Recording from distance measurement test at 8.55 m with a V_{out} of 2V in Matlabs Signal Analyzer tool.	40
4.8	The results of measurements with different V_{out} and distances.	41
4.9	Overview map of the test site provided by Trondheim Vann og Avløp.	41
4.10	Approximately 9.5 seconds of recording by the sonar with no simulated leakages. Red lines show expected time of pinger signal which is calculated below.	42

4.11	Matlabs Signal Analyzer	43
4.12	Matlabs Signal Analyzer with a data overlay.	44
6.1	Summary of key features of the final integrated prototype.	56

1 INTRODUCTION, BACKGROUND & PROBLEM STATEMENT

The purpose of this master thesis is to explore a new low-cost way to locate leakages in water pipes. Due to the hazardous conditions, these environments represent the concept explored need to not only be accurate and reliable but also robust and possible to make cord independent. In this section, the reader will be presented with the approach used, the motivation behind the project as well as the scope and a description of the thesis' structure and the problem space. The goal is to give the reader an understanding of what the problem is and different ways it is solved today. The section is summed up by a problem statement, a requirement for a leakages location device as well as specific research questions, which will be the aim of the master thesis.

1.1 APPROACH: WAYFARING METHOD WITHIN AN ENGINEERING DESIGN FRAMEWORK

In this project, we have used a framework of Engineering design by Pahl & Beitz (2013). Having a clear vision of how the concept should materialize, the system and subsystems have been designed and tested to meet requirements set from the start. This has been followed by more complex tests, testing the integrated system in more realistic environments.

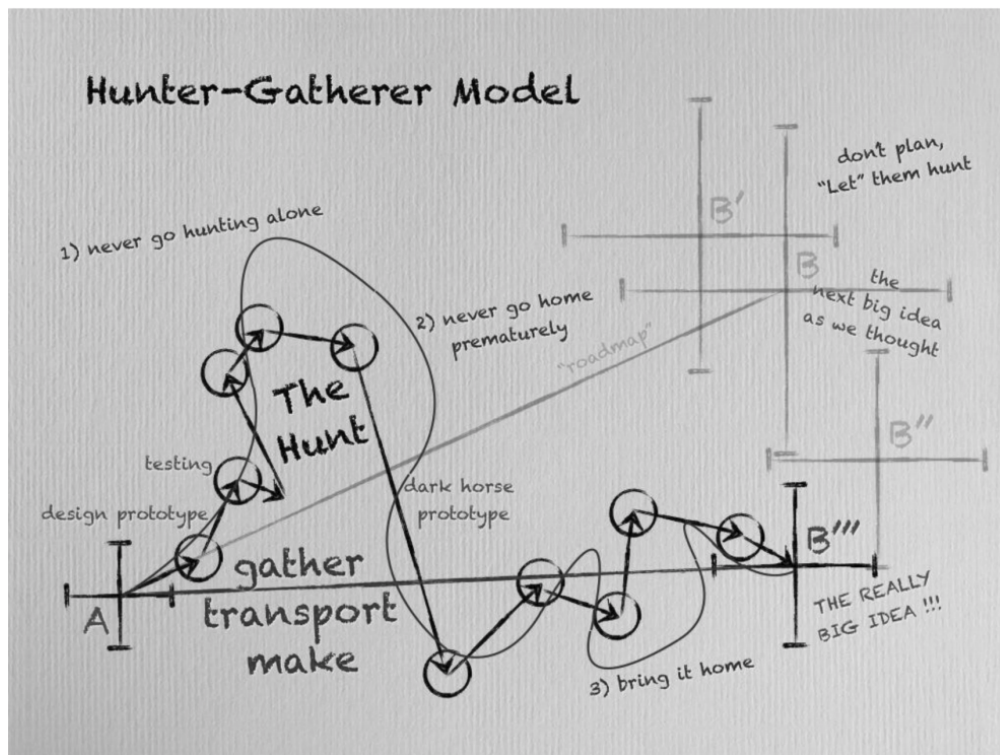

Figure 1.1: The Hunter-Gatherer Model Steinert & Leifer (2012)

Within the framework of Engineering Design, an exploratory approach with an emphasis on testing to learn has been used to gain knowledge of problem space and the concept at hand. This approach is often referred to as the Wayfaring Method as described by Steinert & Leifer

(2012) which again was based on the Hunter-Gatherer Model introduced by Gerstenberg et al. (2015). This method can be visualized as a map where the end-point changes as the path is explored along the way, as with the old wayfaring way of traveling. The direction of where to go next is guided by gained knowledge from newly probed ideas. By building rapid prototypes and testing them in design-build-test cycles, ideally, a team with a diverse skill set probes the solution space. An illustration of this can be seen in figure 1.1. The aim of these prototypes is to rapidly learn more about their current surroundings in the solution space, and not to make perfect solutions. Letting insights guide you through the solution space in this way can lead you to unexpected twists and turns which may help you uncover ‘the big next idea’ and find unknown unknowns as referred to by Sutcliffe & Sawyer (2013) and Gerstenberg et al. (2015). As one learns more about the problem and possible solutions through this journey one can in addition set dynamic requirements. Kriesi et al. (2016) propose that this way of letting the insights from exploring setting the requirements may generate more radical and innovative solutions. Winjum et al. (2017) suggests that one should also prototype different test-setups to measure the solution’s performance to specific individual variables of the intended environment.

One can also adapt the set-based approach as described by Sobek et al. (1999) and Kennedy et al. (2014) in the setting of this project. To identify possibilities and learn more about the different parts of the task individually, the task is separated into subsystems which will be explored separately. The Wright Brothers developed a wind tunnel to generate their own aerodynamic data Kennedy et al. (2014). This is an interesting example of this set-based approach. Using prototypes to build a solid data foundation about the problem. Gathering knowledge and learning through the process of prototyping will be central in this project Berglund & Leifer (2013).

To sum up, the design approach used in this project will be of an exploratory nature, where prototyping leads the way Schrage (1996) within the framework of engineering design. With a strong bias toward building and testing, knowledge and insights about the problem and solutions will be acquired Schön (1983). The set-based mindset will also be a part of the overall approach with prototypes that allow testing with different subsections and configurations.

1.2 MOTIVATION - STATUS OF NORWEGIAN WATER DISTRIBUTION SYSTEM TODAY

In 2017 a report Norsk Vann (2017) was published by bedreVANN on the quality of the 81 Norwegian municipalities’ water distribution and sewage systems. Water loss is defined in this context as the difference between the amount of water supplied to the distribution network and the measured or estimated consumed. Out of the 81 participating municipalities, 9% have a water loss of less than 20%, and 40 % of the municipalities have a water loss higher than 40%. The rapport also reveals that amongst the participating municipalities there is an average 0.06 sewage blockages per km in 2017. Only 50% of the studied pipe network had a sufficient standard. Leakages may also cause drops in pressure which again may cause contaminants to enter the distribution network. Contaminated water can be highly dangerous and may cause sickness and even death. This is not sustainable in terms of health, environment or economy.

1.3 SCOPE

The scope of this master thesis is to introduce a new low-cost way to locate water pipe leakages and testing it. Preventative inspection, leakage prediction, a thorough analysis of how sound waves traverse pipes and user interaction will not be a part of this master thesis.

1.4 THESIS STRUCTURE

First, the reader will be presented with a description of the problem space, ending in a problem statement, a requirement given by Trondheim Vann og Avløp and a set of research questions. The basic theory of relevant aquatic acoustic will be presented to give the reader an understanding of the underlying principles of this prototype, ending in a mathematical equation describing the relationship between the different electronic, acoustic and physical parameters of the concepts. In the next section the development of the prototype will be presented, followed by a description of three integration tests and their results. This will be followed by a discussion of results and methods used, future works and a conclusion.

1.5 THE WATER DISTRIBUTION NETWORK IN TRONDHEIM

To understand the problem space of this thesis properly one needs to have an understanding of the freshwater distribution system in use in Norway today. We will in this subsection elaborate on the situation in Trondheim municipality because it is a relevant example of typical systems in Norway.

In 1863 wooden pipelines leading to common water sources were replaced with cast iron pipes, and in 1880 it was normal to have water inlet in every household. In the mid-1960s "ductile cast iron pipes" were introduced. Today materials like polyethylene (PE) and polyvinyl chloride (PVC) are more common to implement because of their robustness and resistance to corrosion. However, they introduce new challenges in leakage detection methods which will later be discussed. It should also be mentioned that other materials like concrete and copper are operational depending on the use case, diameter and placement in the distribution line.

The distribution network in Norway has typically a pressure of (3-10 bar), which is high compared to other countries. This is because of historical reasons and challenging topography. This is practical in many respects, but it contributes to more wear on the network.

The network typically consists of pipe sections of a 100 meters with a manhole at each end. It is approximately 2 meters beneath ground level with a parallel drainpipe somewhere beneath. The network in Trondheim consists of 800 000 km of piping and 7000 manholes. To prevent households at sea level to have a too high pressure, and household at higher altitudes to have a low pressure; the network is divided into different pressure zones.

According to professionals at Trondheim Vann og Avløp, most of the leakages appear in the "ductile cast iron pipes" from the 1960s. Because of the robust mechanical properties of these pipes, they were implemented directly in the clay foundation found in Trondheim. Time has shown that the clay foundation alone is not suitable in spite of the strong pipes. This wrong assumption is causing several problems and leakages today. The pipes from late 1800 which are implemented in a more robust foundation are less common to cause problems.

However, when a pipe section of this type starts to leak, the walls have typically grown thin by corrosion and fixing a leakage will just trigger other leakages. This is handled by replacing the whole or parts of the pipe section.

1.6 HOW ARE WATER PIPE LEAKAGES LOCATED TODAY?

Currently, four professionals have a full-time job of locating water leaks in Trondheim Kommune. How a leakage is detected, is dependent on the size of the leakage, the material of the pipe as well as accumulated knowledge of the area of the network. They have several tools, techniques, and strategies they use depending on the situation. On a network of this size and age, there is always a certain amount of leakage. The size of the leakage is not the only variable that sets the priority, but factors like the estimated cost of repair and simplicity to located are also considered. Following are a simplistic elaboration of their approach to locating a leakage. In figure 1.2 a professional from Trondheim Vann og Avløp can be seen listening for leakages.



Figure 1.2: A Trondheim Vann og Avløp professional listening for leakages

In key locations in the network, there are flow sensors. They measure the amount of water flowing into, and possibly out of, a closed section of the network. The lowest amount of flow each day is compared to the average measurement. An increase in this variable indicates a possible leak within the closed area. From here with knowledge of the different pipe types, geography, and experience they decide where to start the search. They start by driving to different key manholes and listen to the pipe walls. If an irregular noise is detected it can

be hard to separate it from for instance water use in a near household and it is also hard to decide which of the direction the noise is coming from. Here experience in where to look as well as recognizing different sound signatures with the human ear is key. They check different manholes until the area of interest is narrowed down to a few manholes. Then loggers are put on the remaining manholes and will log sound data for the next night. If lucky they will have put loggers on either side of the leakage and a data analysis program will pinpoint the exact location on the pipe section. If not; they will relocate the loggers and try again. They are also currently experimenting with using more loggers which are designed to monitor key manholes permanently.

There are of course exceptions to this typical leakage location approach. They may get calls from households with abnormally low water pressure, or leakages which are visible from ground level. Clues such as these will make their approach more direct.

1.7 HOW IS THE LEAKAGE REPAIR PRACTICE TODAY?

Depending on pipe material and the piping situation there are different ways to repair leakages. Typically old parts and joints are replaced or even whole pipe section. A common and quick way to repair the leak is to mount a flexible muffle. We will not go deeper into this because of limited relevance for the project. In figure 1.3 a typical leakage can be seen.



Figure 1.3: A Typical Leak

1.8 COMPETING INNOVATIVE SOLUTION

Smartball by Pure Technologies (2020) is a leakage detection method that uses sound and GPS to determine the location of leakages. In short, they allow a hydrophone to traverse the pipe and pick up the sound signature of leakages and gas pockets. To our understanding, they put out sensors with GPS sensors at about every 500 meters of the pipe. Combining detection of when the ball passes these sensors, data from an accelerometer on the unit as well as the assumption that the water flow is approximately constant at 0.5 m/s, the location of the ball during the inspection is calculated.

In 2011 the SmartBall solution was tested in Trondheim Kommune. One of the tests was successful as they managed to locate 5 leakages and one gas pocket in a stretch of 2.5 km. Another test did not go successful. At the moment the ball was released in the pipe a house caught fire opposite of the direction the ball was supposed to flow. The fire brigade used such amounts of water that the direction of the water changed and the ball became lost in the distribution network. The ball was found months later far away from the test site. The episode cost a lot of unplanned time and resources. Listed below are some of the challenges the professionals at Trondheim Vann og Avløp encountered when trying the solution in 2011:

- The water flow needs to be constant and in one known direction, which is challenging to attain in a typical distribution network. It is typically needed to close two valves every 100 meters, which is time-consuming and requires all the valves to be functional. This may also deny water in certain areas. It is also needed to release great amounts of water at the end of the section to ensure the direction of the flow.
- The water speed in the pipe needs to be exactly 0.5 m/s, which is both challenging and cumbersome to attain in this type of water distribution network.
- It is needed to enter the pressured pipe to release and capture the logging unit.
- Sensors are needed to be placed at about every 500 m of the inspected section.
- They were told that the unit had a cost at about 300 000 NOK.

1.9 PROBLEM STATEMENT

Today there is no effective way to inspect longer stretches of water pipes which are low-cost and available for municipalities of Norway. More specifically; typical leak detection methods used today are not effective on modern polymer pipes which are now implemented. This poses as a potential future problem.

1.10 REQUIREMENT BY TRONDHEIM VANN OG AVLØP

Based on interviews and experience with Trondheim Vann og Avløp, we have derived the following requirement to a leakage location device that would be useful to them: The low-cost system must be able to identify leaks in 6" wide polyethylene pipe stretches with at least 1 m accuracy. This requirement was used to set requirements for the different subsystems.

1.11 RESEARCH QUESTIONS

- May we observe water pipe leakages with a low cost self-made audio sensor?
- Is measuring distance with acoustic time-of-flight a possible solution with low-cost equipment?
- If so; is the accuracy and range of the solution satisfactory?

2 THEORY

In this section, the reader will be presented with the basic relevant theory to the concept. This so that aspects and decisions made in prototyping and testing may be better understood. The section concludes with an analysis of the two used transducers and an equation that mathematically describes the relationship between the different prototype parameters and the range of the prototype.

2.1 SONAR

Sonar is originally an acronym for "Sound navigation ranging", and it is a common technique to communicate, navigate and detect objects on or in water. Sound waves are mechanical waves of energy transmitted by alternating rarefactions and compression of the medium it is propagating in. These fluctuations in pressure can be generated by an actuator from an electronic signal and be read by a different sensor. There are two types of sonars, active and passive sonars. An active sonar first sends out a wave and then observe the reflected wave, while a passive sonar only observe signals like a hydrophone.

2.2 SPEED OF SOUND

The speed of sound c in a specific medium the wave is traversing, is determined by the material's bulk modulus B and density ρ .

$$c = \sqrt{B/\rho} \quad (1)$$

Resistance a medium have to compression is determined by the Bulk modulus. Bulk modulus must not be confused with Young's modulus, which determines the strain resistance of a solid material. Even though an increased density reduces speed, it will often be associated with such an increase in Bulk modulus that the speed is increased. An example of this is the fact that sound travels 14 times faster in iron than in air, even though iron is much denser, due to the more significant increase in Bulk modulus. The speed of sound in freshwater is typically around 1420 m/s, dependent on pressure and temperature.

2.3 FREQUENCIES AND WAVELENGTH

The relation between frequency, speed and wavelength can be described by the following equation where λ is the wavelength, v is the speed of the wave in a given medium, and f is frequency.

$$\lambda = \frac{v}{f} \quad (2)$$

The speed of sound in the conditions relevant to this project is approximately 1420 m/s, which makes the wavelength of a 15kHz pulse 95 mm.

2.4 REFLECTION

The measure of the opposition a system has to acoustic flow is called Acoustic Impedance Z , and it has the unit of Rayl or $[\text{Pa}\cdot\text{s}/\text{m}]$. The constant is given by the following function.

$$Z = \rho * c = \sqrt{\rho * B} \quad (3)$$

To illustrate the mechanism behind a wave reflection and a wave transmission, we will consider the reflection of an incident wave on a normal plane boundary, which can be seen illustrated in figure 2.1

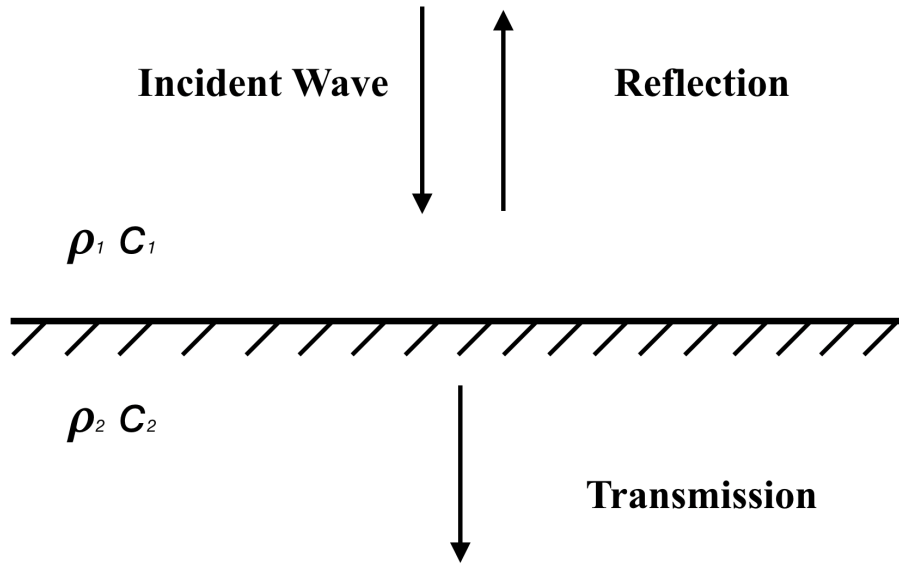

Figure 2.1: Transmission and reflection of an incident wave on a normal boundary

R_s is the reflection coefficient, which is the ratio of the stress (or pressure) amplitude of the incident wave, which makes a reflected wave. The reflection coefficient (R_s) has a value between -1 and 1, where a negative sign represents a 180° phase shift.

$$R_s = \frac{\tau_r}{\tau_i} = \frac{Z_2 - Z_1}{Z_2 + Z_1} = \frac{\rho_2 c_2 - \rho_1 c_1}{\rho_2 c_2 + \rho_1 c_1} \quad (4)$$

The reflected waves can interfere with incident waves, producing patterns of constructive and destructive interference.

The transmission coefficient (T_s) will have a value between 0 and 2. This means that it can increase the amplitude of the signal but will never phase shift. The transmission coefficient (T_s) represents the ratio of the stress amplitude transmitted to the second medium.

$$T_s = \frac{\tau_r}{\tau_i} = \frac{2Z_2}{Z_2 + Z_1} = \frac{2\rho_2 c_2}{\rho_2 c_2 + \rho_1 c_1} \quad (5)$$

Medium	Density (kg/m ³)	Velocity (m/s)	Impedance (kg m ⁻² s ⁻¹)
Air	1.3	330	0.4×10 ³
Water	10 ³	1.5×10 ³	1.5×10 ⁶
PVDF	1.8×10 ³	2.2×10 ³	2.5×10 ⁶
Perspex	1.2×10 ³	2.7×10 ³	3.2×10 ⁶
Quartz	2.6×10 ³	5.7×10 ³	1.5×10 ⁷
PZT (ceramic)	7.5×10 ³	3.8×10 ³	3×10 ⁷
Stainless steel	5.8×10 ³	3.3×10 ³	4.7×10 ⁷

Figure 2.2: Acoustic material data on common materials from Regtien & Dertien (2018)

In figure 2.2 acoustic data on a variety of common materials can be seen.

2.4.1 SOUND LEVEL MEASUREMENT

When measuring sound levels, the two scalars Sound Intensity Level (SIL) and Sound Pressure Level (SPL), are often used. SPL is a figure of the deviance from the ambient pressure at a certain point in a medium. The loudness at a certain distance from a speaker, for instance. SIL, on the other hand, is a measure of how much energy is transformed to sound waves per area. Unlike SPL, this scalar is independent of the medium the sound is traversing and can be calculated by parameters given of the source. When measuring the transmission sensitivity of a sound source, the unit tells how much pressure that is generated per voltage at a certain distance from the source. Sound pressure level decreases with the factor $\frac{1}{R}$ over the distance R .

Numbers are often impractically extreme in the context of acoustic measurements. It is common to use the decibel scale to make this simpler. Note that in water acoustics $1 \mu\text{ Pa}$ is used as the reference value, opposed to $20 \mu\text{ Pa}$ in air.

$$B = 20 \log_{10} \frac{SPL}{1 \mu Pa} \quad (6)$$

2.5 ABSORPTION

The viscosity of the medium determines the absorption of a sound wave. The viscosity and absorption of sound in water depend on variables such as acidity, salinity, frequency, temperature and depth of the propagating wave. Higher frequencies will be more vulnerable to the viscosity because the pressure fluctuates a higher amount per time unit. Three different algorithms are common to calculate the absorption of sound in water. We have chosen Ainslie & McCole (1998) to calculate the absorption in the table below.

Transmitted Frequency	15 kHz
Temperature	3.5 °C
Depth	74 m
pH	8
Salt in fresh water vs oceanic water	0 ppt / 35 ppt
Sound pressure loss (Ainslie and McColm, 1998)	0.096 dB/km / 2.424 dB/km

Table 1

From the calculations, we can tell that the absorption values are insignificant at the relevant ranges. We will not go deeper into the underlying physics of this phenomenon.

2.6 DISSIPATION

A mechanical wave will propagate with an angle. The radiation shape and angle depends on transducer and frequency. As the signal traverse, the signal area will increase, and energy density will decrease. This dispersion energy loss is significant and must also be considered at short ranges. L is the distance from the source to the target in meters, and ϕ is the cone angle. In figure 2.3 these parameters are illustrated.

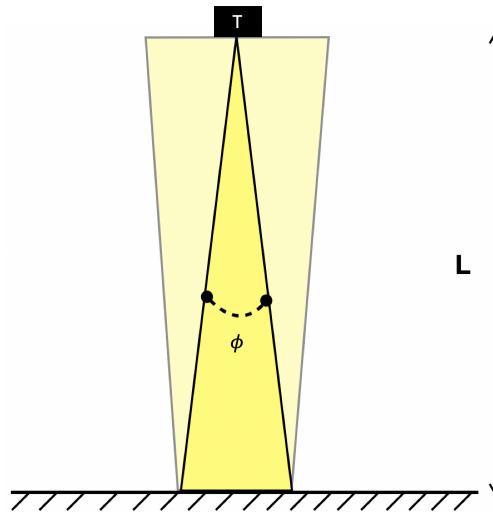

Figure 2.3: Illustration of wave dissipation

$$\delta = \frac{1}{\pi(\tan(\phi/2)2L)^2} \quad (7)$$

When operating with cylindrical transducers, the equation is different. The pinger-transducer, which will later be discussed, has a 180° radiation sector. The relevant variable, in this case, is the radiation angle between the XY-plane and the Z-axis. The beamwidth angle can be determined equation 7 which is given from equation A13.13 in the book Sherman & Butler (2007). Where L is the height of the transducers, and λ is the wavelength.

$$BW \approx \frac{51 * \lambda}{L} \quad (8)$$

This equation is, however, only relevant when $L \gg \lambda$. Since $L = 10$ cm and $\lambda \approx 10$ cm, at 15kHz, one can safely assume that the radiation angle of the transducer is high, and the beam shape is half-spherical according to Norbit professionals. This factor is relevant when considering a transducer's electro-acoustic efficiency but not range. This is because dissipation is already accounted for as both transmission and receiving sensitivity is determined by the pressure fluctuation at 1 m.

2.7 TRANSDUCERS

A transducer is a unit that converts mechanical waves to electronic signals and the other way around. In this subsection, the relevant theoretical aspects of the transducers used will be considered. Two different transducers have been used when developing a prototype in this thesis. One is to emit the pinger signals, which will be referred to as the pinger-transducer, and one is to observe the sound ambient to the sonar, which will be referred to as the sonar-pinger.

2.7.1 THE PINGER TRANSDUCER

This simple, low-cost transducer was found in storage at Norbit's facilities and has, therefore, an unknown name and set of properties. The data on the unit presented is the result of an analysis. In figure 2.4 the pinger-transducer provided by Norbit can be seen.



Figure 2.4: The pinger-transducer provided by Norbit.

Impedance magnitude $|Z|$ has an inverse proportional relationship with the electronic efficiency of a transducer. Note that the electronic efficiency only considers the amount of energy the transducer is able to consume at different frequencies and not the actual amount of energy transformed to mechanical waves. This figure is called electronic-acoustic efficiency and is more complex to derive because one must, for instance, consider the radiation, which is dependent on frequency and energy lost to heat. In this thesis, we had only one transducer available, and another built. We used this parameter only to get familiar with a transducer

and located key frequencies quickly. We will, for that reason, not go deeper into this part of the theory.

In figure 2.5 the impedance magnitude $|Z|$ of the pinger-transducer can be seen. The plotted response indicates that the transducer will work best at 15 kHz, 10.7 kHz and >18 kHz, and that it will be less efficient at 11.5 kHz, 15.8kHz and <8 kHz. Arguably the band-width is not wide enough to use match-filtering and pulse compression, but more on that in further work. This test was performed with the transducer submerged in water because the response will be different in the air. These results were later confirmed with a test observing the SPL at different frequencies, where 15kHz was measured to be the most effective.

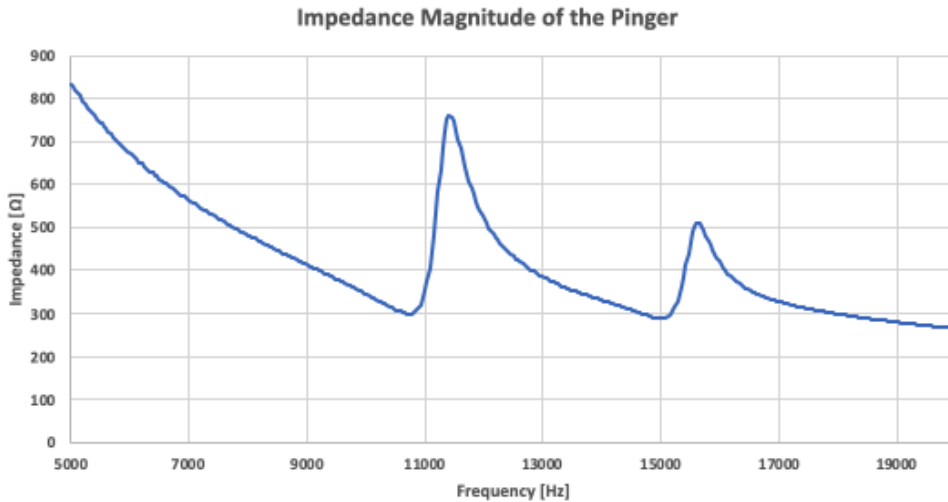

Figure 2.5: Impedance of the pinger-transducer.

To obtain crucial information of the sensor we had to measure and analyze the transducer. The steps of the analysis will not be presented. The acquired information is listed in table 2. Note that the listed transmission sensitivity is valid at 15kHz.

Dimensions	D =90 mm, h = 120mm	Main working Frequency	15 kHz
Weight	1.2kg	Conductance at relevant frequency	0.0035 1/Ω
Radiation Shape	Half Sphere	Impedance at relevant frequency	289 Ω
Transmitting sensitivity [dB]	150.1 dB μ Pa/V at 1m	Transmitting sensitivity	3.2 E2 μ Pa/V at 1 m

Table 2: Relevant data on the transducer captured through analysis.

2.7.2 THE SONAR TRANSDUCER

During the project, a prototype of a transducer for the sonar was made. This development process is described in section 3.3, and the result can be seen in figure 2.6.



Figure 2.6: The sonar-transducer.

To quickly get familiar with the new low-cost transducer from an acoustic point of view, the impedance magnitude plot of the sonar-transducer in figure 2.7 was made. We learned that it has a decent resonance at 15 kHz, a dissonance point at 13 kHz and that it resonates less at frequencies less than 9 kHz, from the figure.

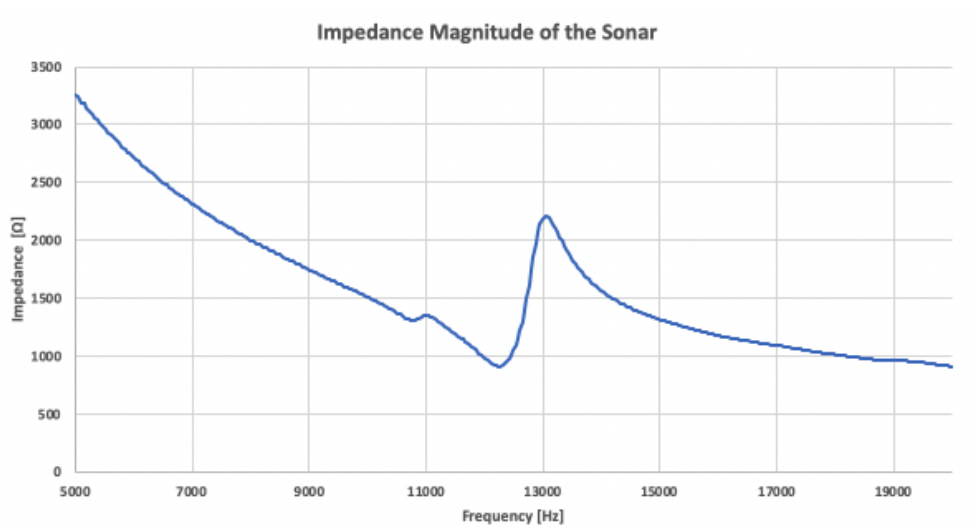

Figure 2.7: Impedance of the pinger-transducer.

2.8 TRANSDUCER ANALYSIS

To be able to choose correct parameters for the system, it is needed an equation to describe the relationship between range and chosen intensity of the emitted pinger pulse. First, we need to obtain the receiving sensitivity R_x of the sonar-transducer at 15 kHz. It was obtained by performing a test in a pool with the pinger-transducer at a distance R from the sonar-transducer. A pulse of a known amplitude V_{out} and a known gain was sent from the pinger-transducer, and the response of the sonar-transducer was observed. The transmission sensitivity of the pinger-transducer was found similarly with a different hydrophone.

1 ms pulses with the frequency of 15kHz and amplitude of 1V were sent out at 2.54 m. The recorded response can be seen in figure 2.8. It is a plot of the .wav-file where an amplitude of 1 represents a signal of 230 mV, and the x-axis is the number of samples. A new pulse being received each second can be seen.

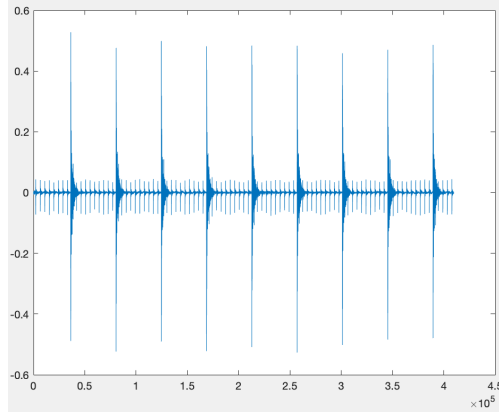

Figure 2.8: The sonar-transducer.

The received ping has an initial amplitude of 0.5276 and declines quickly. The smaller spikes are echos going back and forth in the pool. The parameters used and values obtained are listed in the table below.

V_{out}	Amplitude of voltage of pulse	1 V
G_{outA}	Gain of transmitted signal by amplifier	5
G_{outT}	Gain of transmitted signal by transformer	10
G_{inP}	Gain of received signal by Pi	10
G_{inA}	Gain of received signal by Pre-Amp	10
T_x	Transmitting sensitivity	3.2 E7 $\mu\text{Pa}/\text{V}$ at 1 m
R	Measuring distance	2.54 m
C	Conversion ratio from digital sample value to voltage	230 mV
S_{in}	Digital sample value of signal	0.5276

Table 3: Parameters used and values obtained when testing to find Receiving Sensitivity.

The total signal out:

$$S_{out} = V_{out}G_{outA}G_{outT} = 50V \quad (9)$$

The voltage of the received signal:

$$V_{in} = \frac{S_{in}C}{G_{inP}G_{inA}} = 1.213mV \quad (10)$$

The amplitude of the pressure fluctuation at 1 m from the receiving transducer:

$$PressureAmplitude = \frac{T_x S_{out}}{R} = 6.35 E8 \mu Pa \quad (11)$$

Receiving sensitivity of the sonar-transducer:

$$R_x = \frac{V_{in}}{PressureAmplitude} = 1.9 E - 12 V/\mu Pa \text{ at } 1m \quad (12)$$

In the table 4 the relevant results of the analysis of the sonar-transducer can be seen. Note that the maximum and minimum observable pressure fluctuation is calculated at the end of the section.

Dimensions	D =100 mm, h = 117mm	Main working Frequency	12 kHz and 10.5 kHz
Weight	850 g	Conductance at relevant frequency	7.6161 E4 1/ Ω
Radiation Shape	Sphere	Impedance at relevant frequency	1313 Ω
Receiving sensitivity [dB]	-234.4 dB V/ μ Pa at 1m	Receiving sensitivity	1.9 E-12 V/ μ Pa at 1m
Minimum observable pressure fluctuation	12.1 Pa	Minimum observable pressure fluctuation	1.21kPa

Table 4: Relevant data on the transducer captured through analysis.

2.9 NOISE LEVEL

It is important to know the base level of noise compared to the received signal, to be able to determine the maximum range with a certain set of parameters. The base level of noise represents the level just below the minimum required received signal amplitude. Sounds with a lower signal amplitude than the set noise level is viewed unobservable.

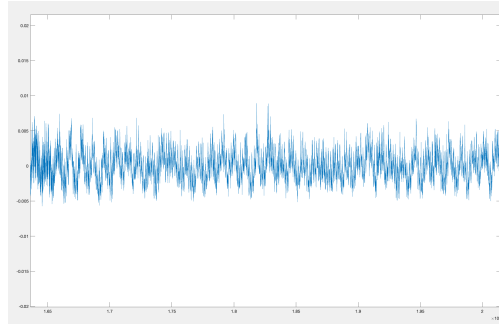

Figure 2.9: The noise level in the pool test.

A recording with only noise can be seen in the figure. From this the noise level can be determined to be at approximately 0.01. This noise level was confirmed by looking at the noise level of several recordings in several environments.

2.10 RANGE EQUATION

By setting the S_{in} to be a minimum of 0.005 above the noise level of 0.01, an equation giving the theoretical range with the given variables can be derived as follows.

$$R = V_{out} \frac{T_x R_x G_{outA} G_{outT} G_{inA} G_{inP}}{S_{in} C} \quad (13)$$

V_{out}	Amplitude voltage of pulse	5 V
G_{outA}	Gain of transmitted signal by amplifier	5
G_{outT}	Gain of transmitted signal by transformer	10
G_{inP}	Gain of received signal by Pi	10
G_{inA}	Gain of received signal by Pre-Amp	10
T_x	Transmitting sensitivity	3.2 E7 μ Pa/V at 1 m
R_x	Receiving sensitivity	1.9 E-12 V/ μ Pa at 1m
C	Conversion ratio from digital sample value to voltage	230 mV
S_{in}	Minimum digital sample value of signal	0.015
R	Maximum theoretical range	4.4 km

Table 5: Values from calculating extrapolated maximum range.

When setting amplitude voltage V_{out} to 5V, which is maximum for our signal generator and determining that 0.015 is the lowest required level of S_{in} , the equation gives that the maximum theoretical range of the system is 4.4 km. One can also determine that S_{in} should theoretically be 0.4228 when $R = 156.3$ m. This figure is relevant later in the thesis. This maximum range is without filtering. With filtering or techniques like signal compression, the range may be more significant. Some of these techniques will be commented on in future works. Using equation 11 and the Receiving sensitivity R_x , we can also calculate that the minimum observable pressure fluctuation with the sonar-transducer is 12.1 Pa, and the maximum is observable pressure fluctuation is 1.21 kPa.

3 PROTOTYPE

In this section, the development of the prototype, and a description of its working principle will be presented. We have divided the prototype into three different parts or subsystems. The three parts are the sonar-transducer, the pinger and the sonar electronics. The different solutions will be described in the necessary level of detail so that the reader may get an understanding of decisions made, as well as weaknesses and strengths with the concept. The three descriptions begin with a presentation of the requirements for the subsystem and end with a description of how the requirements are met.

3.1 CONCEPT OVERVIEW

In a pre-project several ways of measuring distances underwater in low-cost manners were explored, and a concept that could be applied in locating leakages emerged. A leakage in a pressurized water pipe generates sound, which can be detected and used for determining location. Acoustic leakage detection has been proven to be effective Fantozzi et al. (1993), Fuchs & Riehle (1991) and Liston & Liston (1992) and is in common use in the water industry. In this master thesis, we propose putting the hydrophone inside the pipe instead of statically detect leakages with hydrophones or microphones. By letting the water carry the sonar through the pipeline, long stretches of the pipeline may be inspected effectively, and leakages, as well as other data, may be observed. An illustration of the working principle of the concept can be seen in figure 3.1.

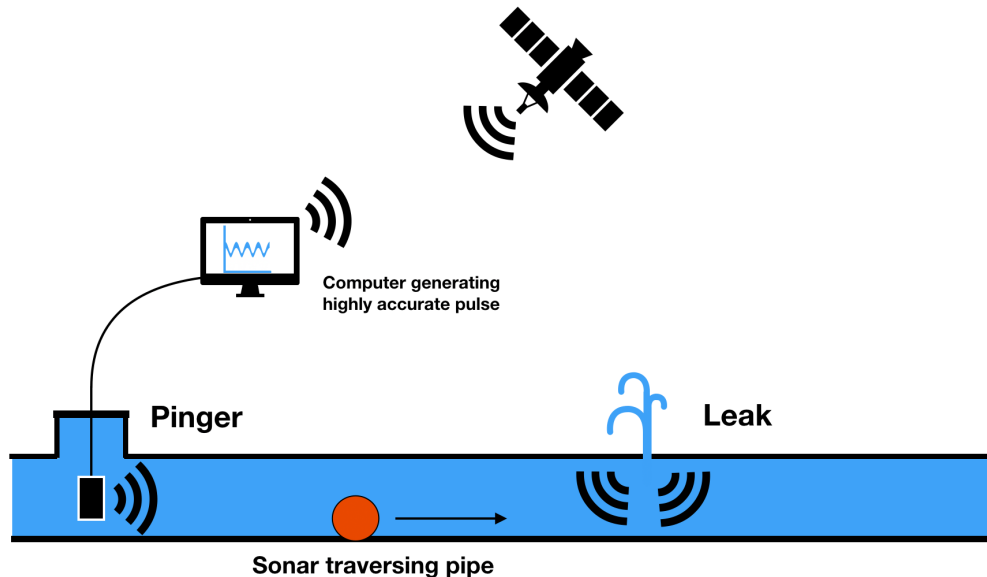

Figure 3.1: Working principle of the concept

One of the biggest challenges with this concept is not to detect leakages, but to determine the location of the sonar at points in time. We have solved this by having a pulse sent out from the start position with accurate rhythm. By knowing the speed of sound in the medium and, the point in time, the signal is emitted and received, the distance between the pinger

and the sonar can be calculated. It was chosen to divide into three subsystems because they in themselves had precise requirements that would have to be met individually. It was, therefore, effective to develop and test them concurrently.

3.2 PINGER

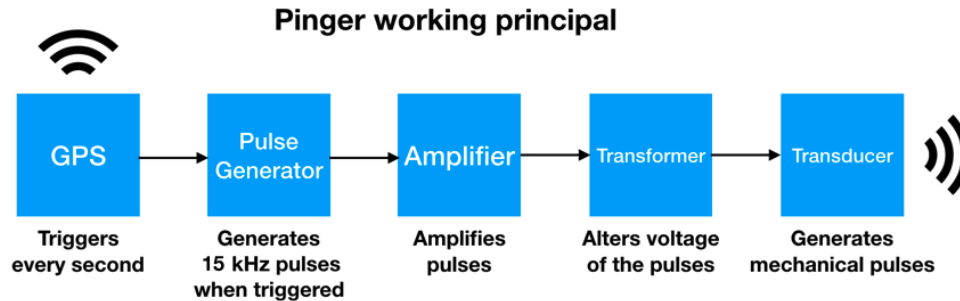

Figure 3.2: Pinger working principle

This subsection describes the development as well as the working principle of the pinger subsystem. A pinger is a device that emits pulses at a specific points in time. In this solution, a pinger is used to send out a pulse through the pipe every time a second passes. A GPS which is locked on a satellite is used to determine the exact time, because the accuracy of this pulse is critical. The GPS triggers the pulse generator to generate a pulse of, for instance, 15 kHz and 1 ms. This signal is amplified before the transducer alters the signal to a mechanical wave. An illustration of the working principle of the pinger can be seen in figure 3.2.

3.2.1 REQUIREMENTS FOR PINGER

The general requirement of this subsystem is that it needs to emit an accurate pulse that reaches the sonar in a pipe. This requirement is summed up by the more specific and testable requirements below.

- The pinger needs to be able to emit a mechanical pulse through at least 150 m in water.
- The frequency of pulse needs to make sense in terms of pipe dimension and transducer.
- The amplitude of the pulse needs to be amplified to a necessary degree.
- The pinger needs to communicate directly with satellites to ensure accurate triggering of the pulses.
- The pinger needs to be firmly mounted inside the pipe at the center of the pipe cross-section.
- The pipe mount needs to be watertight at 10 bar and let a cable go from the inside to the outside.

- The resolution distance measurement needs to be at least 1 m with the sonar moving at 1m/s.

3.2.2 TRANSDUCER

The pinger-transducer which is used to emit the pinger signal, was an old unit found at Norbit. This unit has been described in necessary level in section 2.7.1.

3.2.3 PULSE GENERATOR

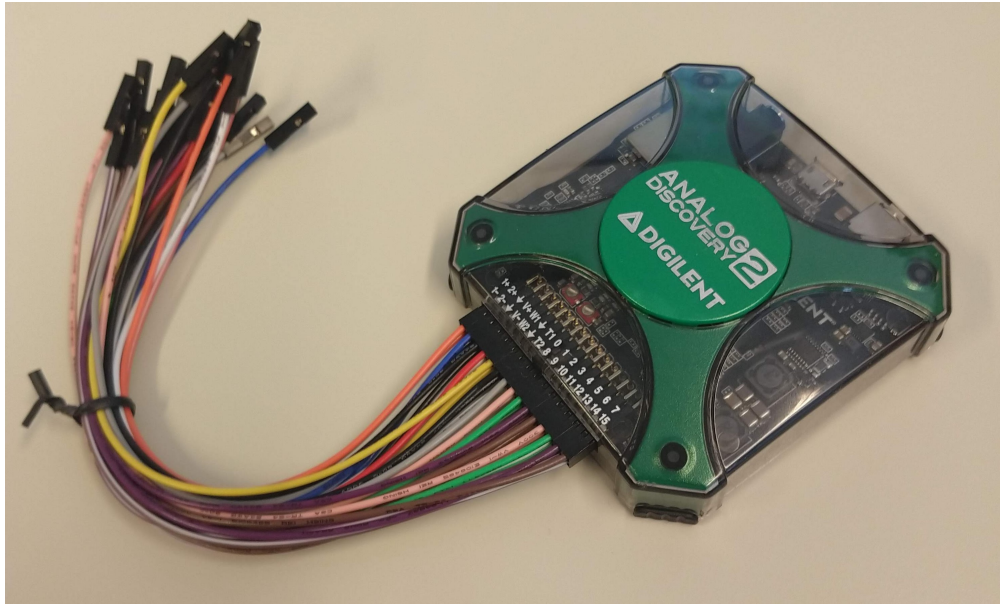

Figure 3.3: The oscilloscope for Pulse Generation: the Analog Discovery 2 board

To make a working prototype of a pinger, we would need one unit to generate waves for the pinger to emit. For this, we used the Analog Discovery 2 board, which can be seen in figure 3.3. This is a low-cost and pocket-size oscilloscope with many functionalities. It is easy to change all parameters on this oscilloscope and adapt it to different prototypes and applications. In a more high-resolution prototype, this unit can be replaced by a simpler specialized circuit if we are to optimize for size, simplicity, or cost. The maximum voltage amplitude of the signal sent from the oscilloscope board is 5 V.



Figure 3.4: The oscilloscope interface while armed to generate pulse when triggered

In figure 3.4 the display of the interface to the oscilloscope can be seen. The bottom half on the left shows an 11kHz, 2V signal being ready to generate for 100 ms followed by a 200 ms wait when triggered. The exact parameters depend on the different tests performed. The top half is the scope used in module testing as well in other electronic diagnostics. For the working prototype, however, this part is not in use. On the bottom right, there is a simple power supply we used to power the GPS unit because it was convenient.

3.2.4 AMPLIFICATION

A transformer and a regular amplifier for a typical sound system in a car was used to amplify the generated pulse. For the prototype, we used a Boschmann PCH-2682EX, as can be seen in figure 3.5. It has a minimum gain of 5 and a maximum gain of 50 or ~ 20 V in amplitude. The absolute maximum of ~ 20 V is due to the voltage of the power source the amplifier is designed. There was a rotational lever to regulate the amount of gain. It was problematic that there was no way of directly knowing the exact amount of gain except for at the maximum and minimum. We could reach the voltage maximum with the signal generator and the minimum level of 5. This resulted in that we only used the minimum gain, and that we used the signal generator to regulate the signal strength.

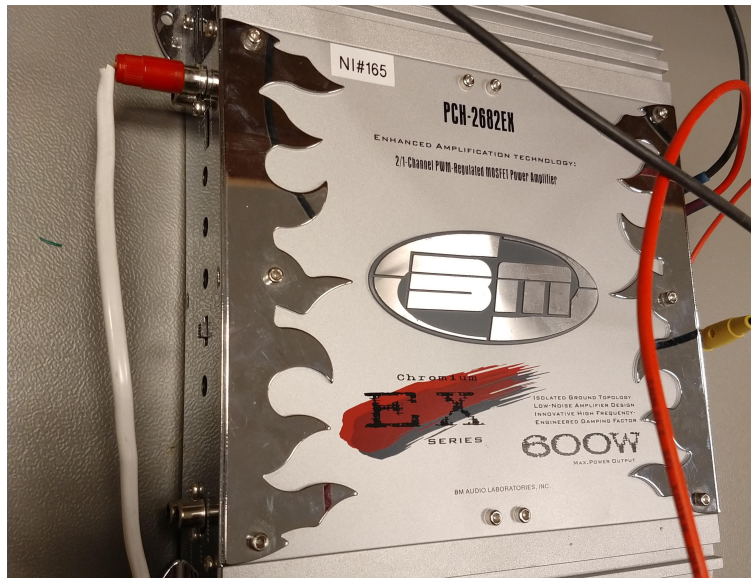

Figure 3.5: The car-amplifier used to amplify the pulse

3.2.5 TIME TRACKING

For time tracking with high precision, we used two GPS units. One to trigger the pulse from the pinger and one to keep time in the sonar. A GPS or Global Positioning System is a unit that determines the geographical position of the unit through communication with several satellites. To be able to do this, the satellites and GPS units require highly accurate synchronized clocks, which we exploit in this prototype. There will be no closer elaboration on the theory behind a GPS because it is considered not relevant to understand the working principle of the prototype.



Figure 3.6: One of the GPS-units connected to antenna.

For the prototype, it was used Ublox LEA-M8T-0-01, which can be seen in figure 3.6.

The connected wire on the top right is the antenna, and it can be seen in the top middle of the picture. On the left side of the circuit, there are three wires. From the top: power, common-ground and "Time 1". The GPS is programmed to set the "Time 1" pin to true every time a second passes. The wires are twisted as a measure to limit noise.

When testing, the GPS unit in the pinger has lock-on with satellites through the duration of the test to ensure that the time is as accurate as possible. Through testing, it was found that the unit pulls 0.04 A.

3.2.6 PINGER MOUNT

The mechanical structure of the pinger is critical. The structure must be able to hold the transducer elevated in the middle of the pipe cross-section encumbered by varying water flows and pressures. The main challenge, however, is to have a lid that is water and pressure-tight at 10 bar, while a signal cable runs from the outside and in. The final result can be seen in figure 3.7.



Figure 3.7: The final mechanical structure of the pinger.

An aluminum pipe was welded to a disc on the left and to a made lid for the pinger-transducer on the right. A threaded steel pipe was put through the aluminum pipe with bolts on either side to compress the aluminum disc against the blue steel armature lid. A regular cable runs through the steel pipe. All components are made from the ground up, except the blue armature lid, the transducer and the cable. The mechanical structure is designed in a way that the high pressure in the pipe works to further make it watertight. To test if the requirement was met, the lidded transducer was tested to be watertight at 20 bar in a pressure chamber. A similar armature we were building the pinger to fit can be seen in figure 3.8.



Figure 3.8: A typical armature that connects pipes in manholes. The picture is provided by Trondheim Vann og Avløp.

3.2.7 HOW REQUIREMENTS ARE MET

Testing of the subsystem with the chosen amplifiers indicates that it theoretically will have a range greater than 200 m. See the calculation in subsection 2.10. Ideally, the optimal frequency for the pinger-transducer would also have a greater wavelength than the pipe-diameter. Unfortunately, this was not the case with the transducer available to us, so the main frequency of 15kHz was chosen for its superior electro-acoustic properties with the transducer at hand. See section 2.7.1 for the reasoning for the decision made. The built pinger mount meets both relevant requirements and is also tested in a pressure chamber to ensure that it is watertight. The chosen GPS-technology has sufficient accuracy, and the resolution for moving distance measurement is ensured with transmitting pulses with a frequency of 1 Hz.

3.3 SONAR TRANSDUCER

The transducer is the part of the sonar which transforms the ambient mechanical waves to electronic signals as well as contains all the electronics in a watertight environment. This subsection describes the development as well as the working principle of the sonar-transducer. The sonar-transducer was built from the ground up during this project.

3.3.1 REQUIREMENTS

The general requirement of this subsystem is that it needs to be sensitive enough to detect leakages and a pinger pulses, while carrying all electronics in a robust and watertight way. This requirement is summed up by the more specific and testable requirements below.

- It must be able to register relevant frequencies from leakages and pinger.
- It must be able to contain all electronics for the sonar physically.
- It needs to be able to roll in all three taxis inside a 6" pipe.
- It must be watertight at least at 10 bar.
- It must have a total higher density than water so that it will not float.
- Noise created from motion cannot saturate the transducer.

3.3.2 DEVELOPMENT

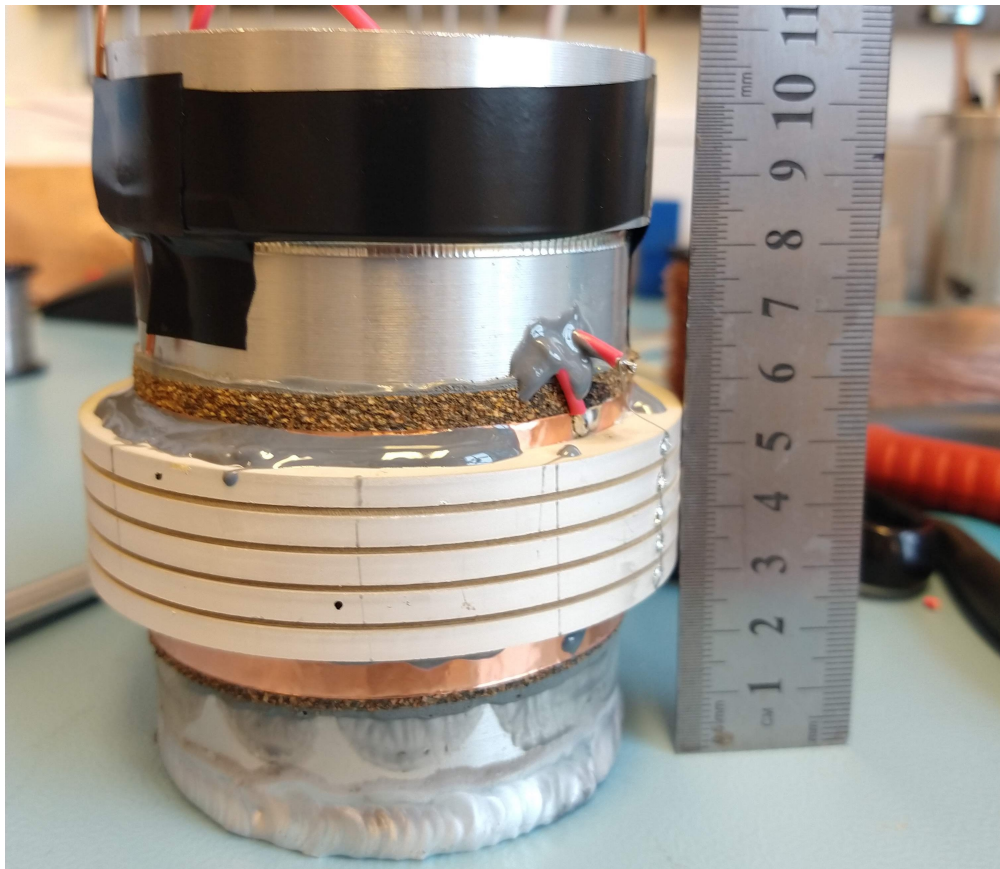

Figure 3.9: The sonar-transducer in the making process.

In figure 3.9, the unit can be seen before it is cast in epoxy and lathed. In the middle, there is a thin-shelled aluminum cylinder with a welded lid on the bottom. The surrounding layer of cork wood and thin cardboard between the ceramic rings allow the five ceramic rings to vibrate freely.

The ceramic rings have the property that they vibrate radially when subjected to certain frequencies. A piezoelectric element is located on the inside and outside of the cylinders. The

deformation of the elements caused by the vibration generates a subtle voltage inequality between the outside and inside. This voltage difference is an electronic representation of the ambient mechanical waves, and it is measured and logged continuously by the electronics in the sonar. The five rings are connected in parallel to increase the sensitivity of the unit. The wires from each side go through the shell wall to the inside of the unit.



Figure 3.10: The mobile transducer with a epoxy layer and water tight lid.

The unit was cast in epoxy, lathed, and given a watertight lid on top. The lid was tested to be watertight at 20 bar, which we considered sufficient as the maximum probable pressure in the pipes during testing is 10 bar. The result can be seen in figure 3.10.

3.3.3 HOW REQUIREMENTS ARE MET

The transducer is able to receive all frequencies from 0 Hz to 22kHz to a satisfying degree. The outer dimensions of the prototype are small enough to be able to roll in a 6" pipe in all three axes. The inner dimensions are great enough to fit the electronics. When housing the intended electronic, the sonar has a higher total density than water, and it is tested to be watertight in at least 20 bar. Recordings have been performed when the unit is rolling. The rolling generates a slight noise, but it is deficient compared to the extreme values that a leakage generates, which can be seen in the next section. This indicates that the transducer

is able to detect leakages while moving. As we did not have the opportunity to test the sonar moving in its intended environment, we will not go further into this. The noise of motion does not saturate the transducer, so the requirement is met. The final physical properties of the sonar transducer are listed below.

Property	Value
Height	117 mm
Diameter	100 mm
Volume	0.9 L
Weight with electronics	1.13 kg
Density	1.26 kg/L

Table 6: A summation of the physical key features of the sonar transducer.

3.4 SONAR ELECTRONICS

The purpose of the sonar electronics is to amplify, convert and store the analog signal read from the transducer. This must be done automatically for the whole duration of an inspection, and the data needs to be stored in a way that makes it possible to connect the recordings to a correct timeline. An illustration of the working principle of the sonar electronics can be seen in figure 3.11.

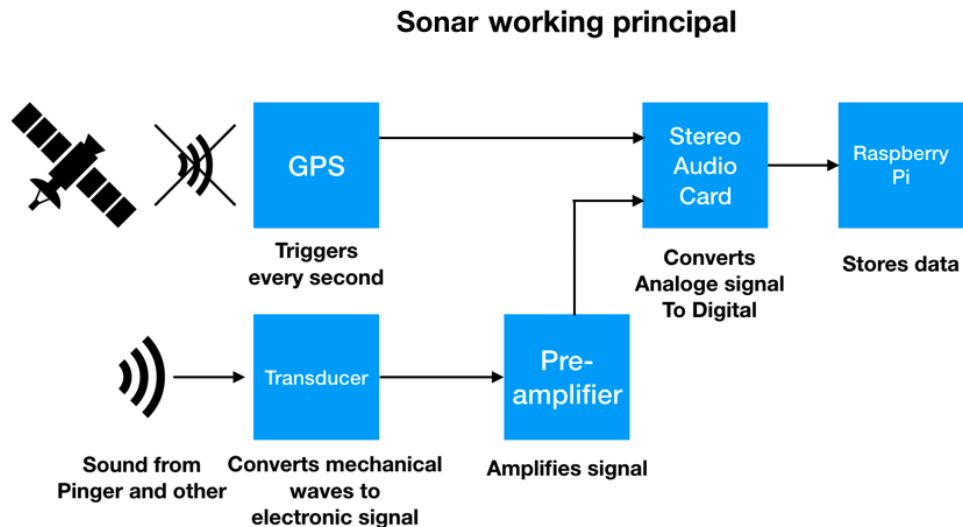

Figure 3.11: Sonar working principal

3.4.1 REQUIREMENTS

The general requirement of this subsystem is that it needs to be able to record all relevant data for the duration of an inspection. This requirement is summed up by the more specific and testable requirements below. Note that the last listed requirement has emerged when building and testing the subsystem.

- It needs to fit inside the sonar-transducer.
- It needs to record autonomously for at least three hours.
- It cannot overheat in three hours
- Battery life needs to be at least three hours
- File-size and storage capacity needs to fit three hours of recording
- The data needs to be stored in such a way that it is possible to calculate distance accurately from it and that it can be synced with a correct timeline.
- It needs to record an accurate time-pulse from a GPS and record signals from the transducer simultaneously.
- The GPS needs to be able to be synchronized before and after entering the pipe.
- It needs to amplify signals from transducer if necessary.
- Abrupted loss of power or other malfunctions should compromise as little recorded data as possible.

3.4.2 PRE-AMPLIFICATION CIRCUIT

The pre-amplification circuit is intended to amplify the signal that comes from the transducer. The board itself was also made to be the electronic link between all the different components in the sonar, for convenience.

This circuit was originally also intended to supply power to the sonar with a compact lithium battery. Testing showed that this solution did not provide sufficient amounts of current, and an alternate solution for providing power was made. This rendered some of the pre-amplification circuit obsolete. A sketch of the pre-amplification circuit can be seen in figure 3.12, and table 7 explains the purpose of the different parts.

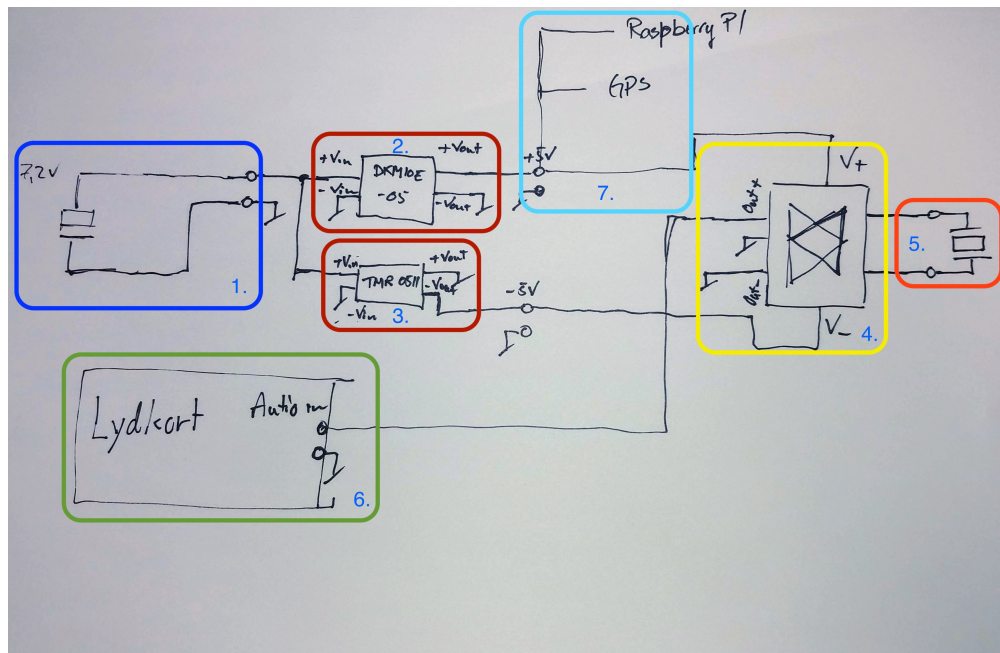

Figure 3.12: Sketch of the pre-amplification card circuit.

Index	Name of Circuit Part	Purpose or Function
1.	Battery	Provide power to the circuit. The original 7.2 V lithium battery was replaced by a 5 V alkaline battery.
2.	DKM10R - 05	Convert the + 7.2V signal to a stabile + 5V signal for the amplifier.
3.	TMR 0511	Convert the + 7.2 V / + 5V signal to a stabile - 5V signal for the amplifier.
4.	Amplifier	Amplifies the signals from the transducer (5.) with the positive and negative voltages from 2. and 3.
5.	Transducer	Creates a electronic signal from ambient mechanical waves.
6.	Sound Card	Converts the amplified analog signal to a digital signal for the computer to read.
7.	Initial Power Source	Originally this point would provide 5V for the other components in the sensor package. This point was moved directly to the battery (1.)

Table 7: This table explains how the different parts of the pre-amplification circuit work.

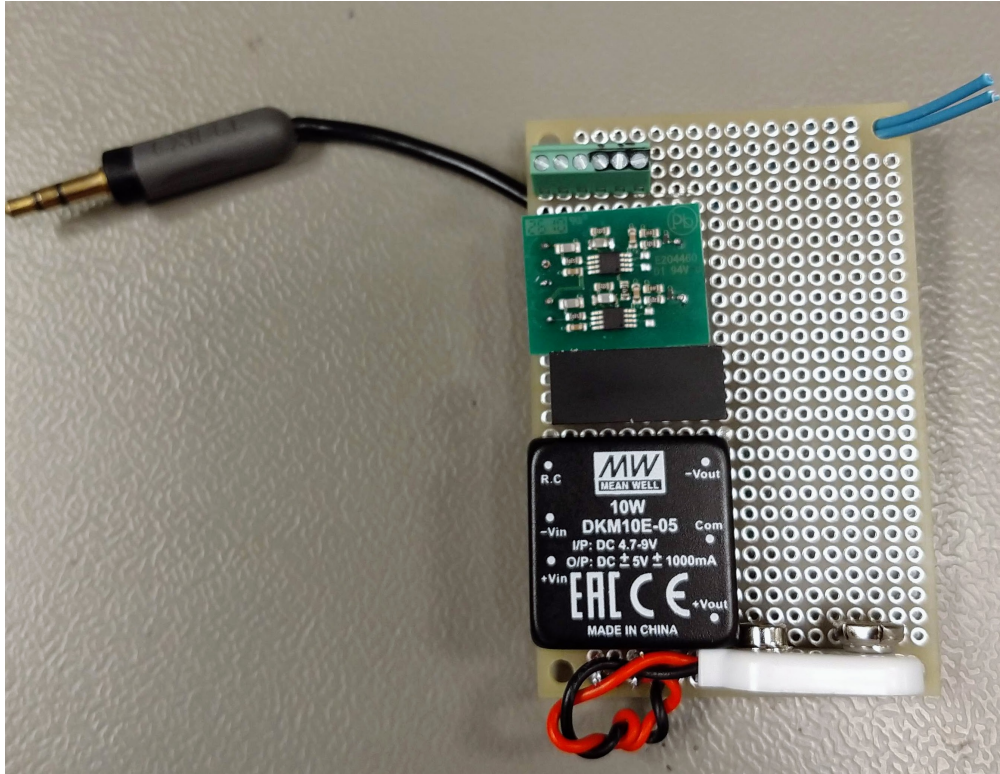

Figure 3.13: The pre-amplification card circuit.

Figure 3.13 displays the up-side of the finished pre-amplification board. The wire on the top left is the output for the sound card, and the two blue wires at the right are the input from the transducer.

3.4.3 SOUND CARD

The purpose of the sound card in this prototype is to convert the analog signal to a digital signal, which then can be logged with an on-board computer. It was used a sound card with two audio-in ports, originally. One input from the local GPS unit and one to pick up the sound from the transducer. The sound card we used was a USB-MA form Andrea Communications which has a stereo audio-in with a 16-bit resolution.

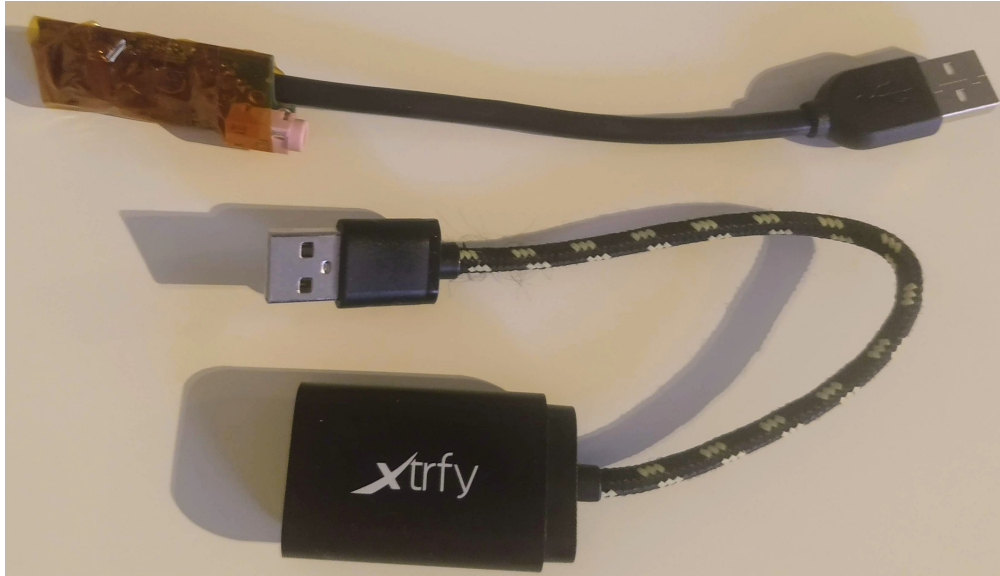

Figure 3.14: The two sound cards used for testing. Xtrfy SC1 at the bottom, and the USB-MA from Andrea Communications with altered form factor at the top.

The form factor of the sound card in the technical data provided by the retailer, mismatched with the product we received. We, therefore, had to alter its form-factor. The result can be seen at the top of figure 3.14. The sound card with our configuration functioned at times. It was not always seen by the computer it was connected to. This critical instability, resulted in that we switched to a reserve sound card with only one channel, in the final prototype. This, the Xtrfy SC1 Sound Card can be seen at the bottom of figure 3.14.

3.4.4 COMPUTER AND SOFTWARE

Raspberry Pi Model A+ was used as the on-board computer with the purpose of logging all the incoming data. A Raspberry Pi is a small unit that can serve as a computer and a microcontroller with a variety of applications. It was chosen because it is low-cost, power-efficient and the fact that it is powerful enough to run the software in this prototype. The Model A+ was chosen instead of its more common brother, the Model B+, because of its critical smaller form factor. Note that this general-use computer easily could be replaced in a higher resolution prototype with a more specialized circuit that is optimized to our needs in terms of cost, power-efficiency and form factor.

The Raspberry Pi holds a script that starts running automatically when the Pi is powered. The script records incoming data from the sound card through the USB-port and stores it in approximately 9 second long sound bites. The approach of storing the data every 9 seconds instead of having one continuous recording was chosen to make the prototype less vulnerable to unexpected power downs or other malfunctions. This requirement emerged when performing testing. The file type chosen is 2 channel 24-bit .wav files. The mentioned script can be found in appendix A. The Raspberry Pi we used can be seen in figure 3.15.

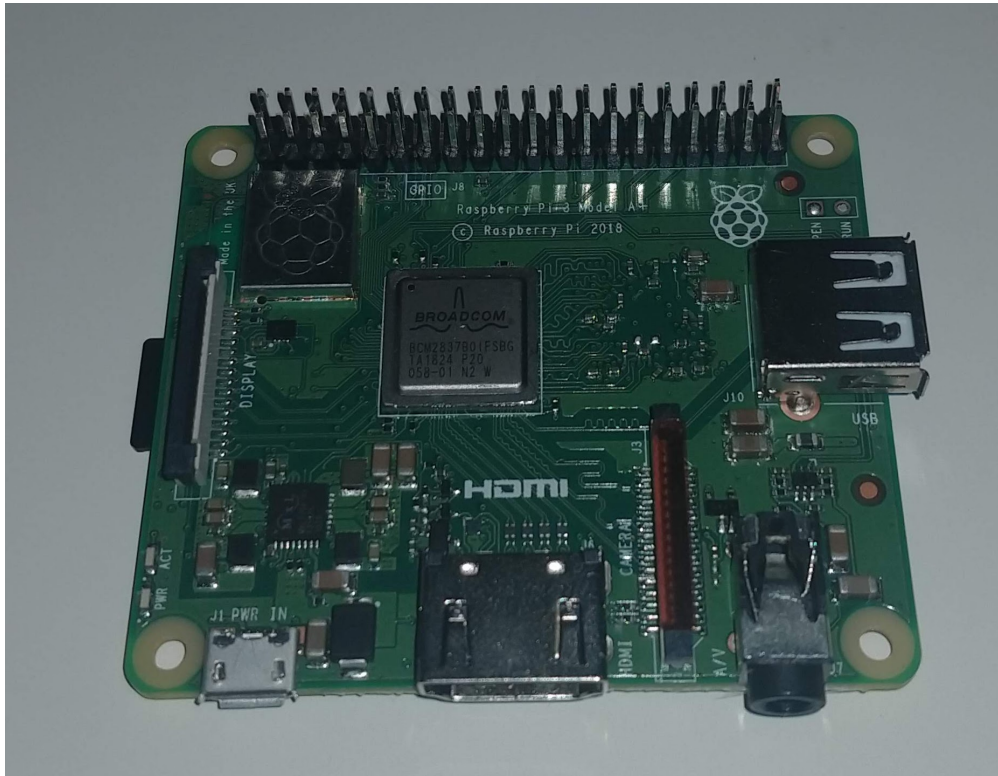

Figure 3.15: The Raspberry Pi 3 Model A+ was used as the on-board computer.

The Pi is also programmed to connect to a certain shared cellphone Wifi network when it is turned on. This, to synchronize its perceived time and date. The synchronized clock is important to keep track of when the different files are recorded. Each file is given a name which is containing information of date and time in minutes and seconds of when it is recorded.

Amount of data per sample	24 bits / 3 Bytes
Number of channels	2
Sample rate	44100 Hz
Amount of data produced every second	0.26MB
Amount of data produced every hour	936 MB
Available data capacity with chosen drive	~ 8GB
Maximum Recording time	~ 8.5 hours

Table 8: Calculation of data storage requirements and maximum recording time.

It is important that the reader does not confuse this clock with the one of the GPS-es. The clock on the Pi is more inaccurate than a synchronized GPS and is not suitable for acoustic distance measurement. However, it is accurate enough to keep track of the different recordings.

3.4.5 POWER SUPPLY

A regular power bank battery was used to supply the sonar with power. This because of it's price and convenience to acquire and recharge.



Figure 3.16: The battery used to power the sensor package with power.

Its original aluminum plastic container was removed, and the circuit converting the power was bent to the wall of the battery, as can be seen in figure 3.16, to fit in the limited space in the container. It was also wrapped in non-conductive temperature resistant tape to protect the other components.

The battery delivers 5 V with a maximum of 1 A, and it contains 2600 mAh. From testing the power consumption of the finished sensor package is measured at 0.29 A when fully operational. With the chosen battery that gives a battery life of almost 9 hours which is more than satisfactory.

GPS	0.2 W
Rasberry Pi	1.2 W
Pre-Amplifier	0.05 W
The measured current drawn when operational	0.29 A
The sum energy requirement	1.45 W
Battery Capacity	2600 mAh
Battery Life time	~ 9 hours

Table 9: A summary of power consumption and battery life.

3.4.6 TIME TRACKING

The time tracking unit used in the sonar electronics is the same as the one used in the pinger, so we will not describe the unit in further detail here. There are however some important details of the GPS unit in the sonar which will be elaborated.

The unit in the sonar has only lock-on before entering the pipe to synchronize its clock. It also has lock-on with the satellites as soon as possible after exiting the pipe to re-synchronize

in case the clock in the unit has drifted during the test. Testing indicates that this drifting is neglectable in the time span of three hours, but this has not been tested while in its intended environment.

When using a sound card with one audio-in channel, the time-stamp of the GPS is signaled on the same channel as the sound recording. This represents a blind spot because it, through testing, has shown to saturate the recording at these particular points in time. By saturated recording, it is meant that the recorded value of the samples is maximum. This is above 1 in value, rendering the sonar blind for other sounds. Through testing, it has been found that typically four samples are set to one as a consequence of the time-stamping signal, on the final prototype. With a sampling rate of 44.1 kHz, this gives a blind spot of 90 μ s recording time and limits the minimum range to 130 mm. This is found to be acceptable considering the use-case.

3.4.7 HOW THE REQUIREMENTS ARE MET

The electronics were built to fit inside the sonar transducer successfully. Theoretically, the unit is able to record for more than eight hours, and testing has confirmed that it is able to record well over the required three hours. To be able to connect the recordings with a correct timeline, the Raspberry Pi is programmed to synchronize with a cellular network, and robustness against power loss is ensured by storing the data every nine seconds. The unit has proven able to record accurate time-pulses and sound to a satisfying degree through testing.

3.5 SUMMARY OF THE FINAL PROTOTYPE

A prototype of the envisioned concept has been designed, built and tested, in several cycles. The three subsystems have been developed and tested separately, and all meet their preset and emerged requirements. The key features of the prototype are listed below. Note that these values are measured and calculated in a laboratory setting, and may be different in other environments. For instance, is the value of the theoretical range extrapolated from measured properties of the prototype with known theory. How it is derived can be seen in subsection 3.9. How the prototype performs in its intended environment will be explored and tested in the next section.

Prototype Property	Value
Weight of Sonar	1.13 kg
Volume of Sonar	0.9 L
Operational Time	> 4 hours
Theoretical Range	130mm - 4.4km
Lowest observable SPL amplitude	12.1 Pa
Highest observable SPL amplitude	1.21 kPa
Distance measurement rate	1 Hz

Table 10: Features of the final prototype

4 INTEGRATION TESTING AND RESULTS

Several tests have been performed in this project, but three integration tests test the core functionalities of the concept and prototype in a realistic environment. In this section, gathered data from integration tests will be presented, the post-processing of the data will be described, and the following results and conclusions will be presented. The purpose is to give the reader a thorough understanding of how the tests were performed, what data was gathered, how the data was analyzed and understood, and what insights that was captured.

4.1 LEAKAGE DETECTION

The sonar was put in water-filled pipes with 3.5°C and 7.3 bar to test the sonar's ability to detect leakages. Leakages were simulated by opening a valve to release a tiny flow of water from the system resulting in the sound signature similar to a typical leakage. This is the way the professionals simulate leakages when they are training. Leakages were simulated at 156.3 m and 0.5 m from the sonar at different points in time. On the professionals' advice, we avoided being in the manholes when the valves were opened for safety purposes. This prevented us from quantifying the openings of the valves or the amount of water flowing.

In figure 4.1, a screenshot from the Matlab Signal Analyzer can be seen. The bottom part displays the whole signal in the time domain. The top part shows the power spectrum in the frequency domain. It displays the amount each frequency from zero to 22050 Hz is represented on average for the chosen time section of the signal, which in this case, is approximately nine seconds. The maximum registered frequency is 22050 Hz, because it is half of the sampling rate, following the Nyquist rule. The section in the middle is a combination of the one at the top, and the one at the bottom. Time is on the x-axis, frequency is on the y-axis, and the intensity at a small section in time is represented by color.

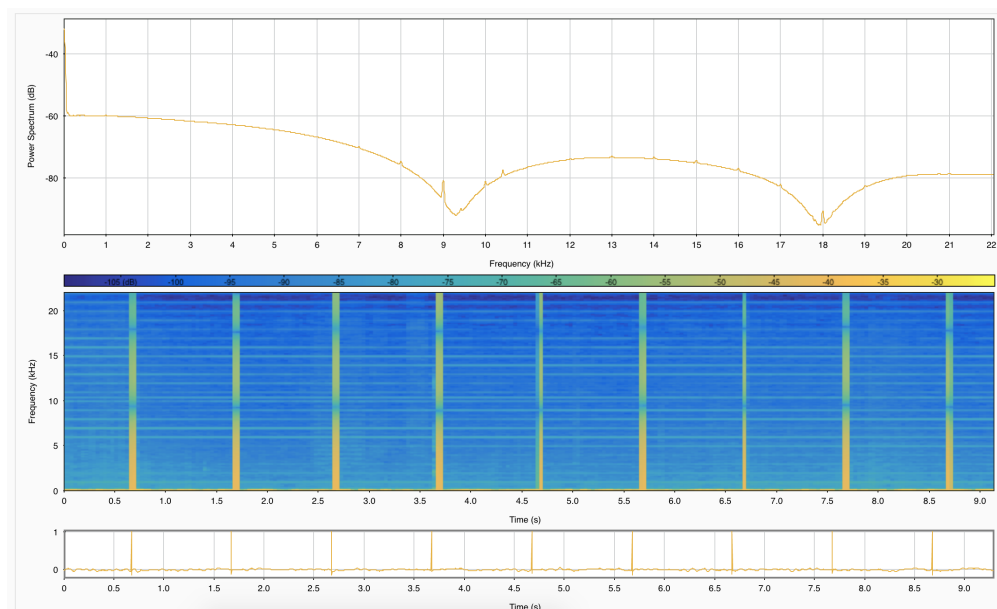

Figure 4.1: A recording with no simulated leakages in Matlab Signal Analyzer.

Figure 4.2 is a screenshot of an analysis of a recording with a simulated leakage at 156.3 m. When comparing figures 4.1 and 4.2, it is hard to distinguish them. It is not the same recording, but there is no obvious difference in them in terms of frequency, intensity, or other patterns. When listening to the recordings, there is no notable difference either. To not be able to hear leakages with hydrophones at 156.3 m, fits well with the professionals' experience.

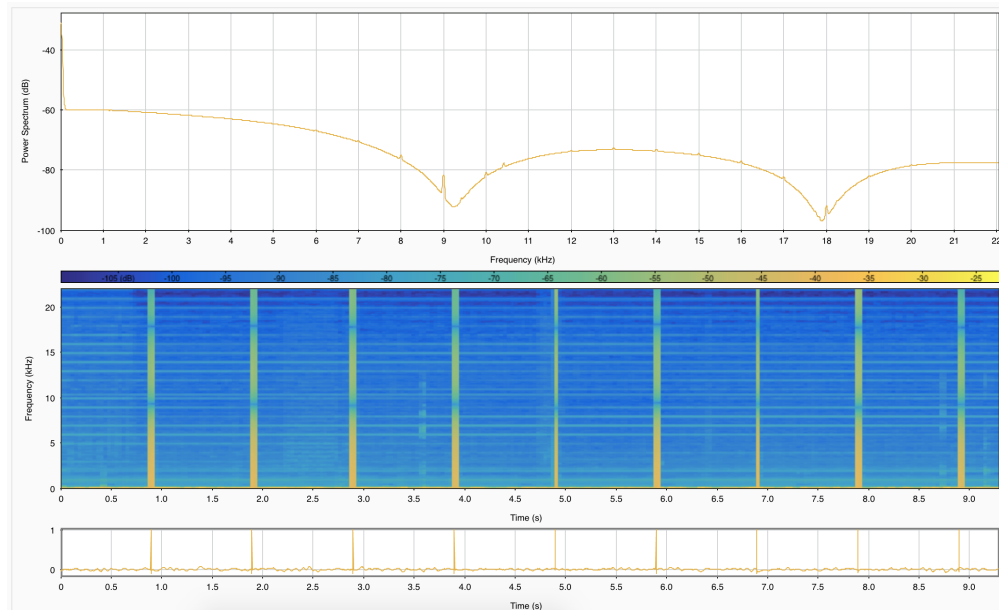

Figure 4.2: Plot of recording of simulated leakage at 156.3 m in Matlab Signal Analyzer.

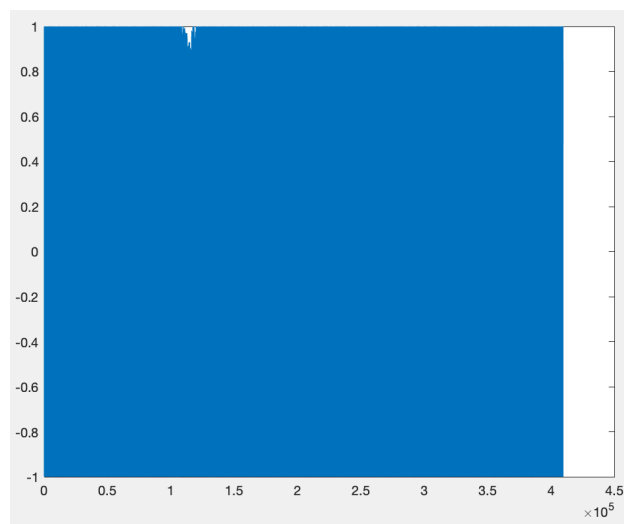

Figure 4.3: Plot of recorded simulated leakage at 0.5 m.

In figure 4.3, a plot of the recording of the simulated leakage at 0.5 m can be seen. The same recording can be seen in the Matlab Signal Analyzer tool in figure 4.4. Compared to

figure 4.1, a distinct increase in amplitude across the whole time sequence can be seen. All frequencies have an increase and the lower ones increase the most. When listening to them with the human ear, one can easily distinguish them. The signals are off the scale. This means that the sonar-transducer is saturated. Using equations 11 and 13, we can calculate that the pressure amplitude of the noise is more than 1.2 kPa. The theoretical range for this pressure amplitude is more than 3.5 m, which is not very helpful, as we cannot know the exact theoretical range.

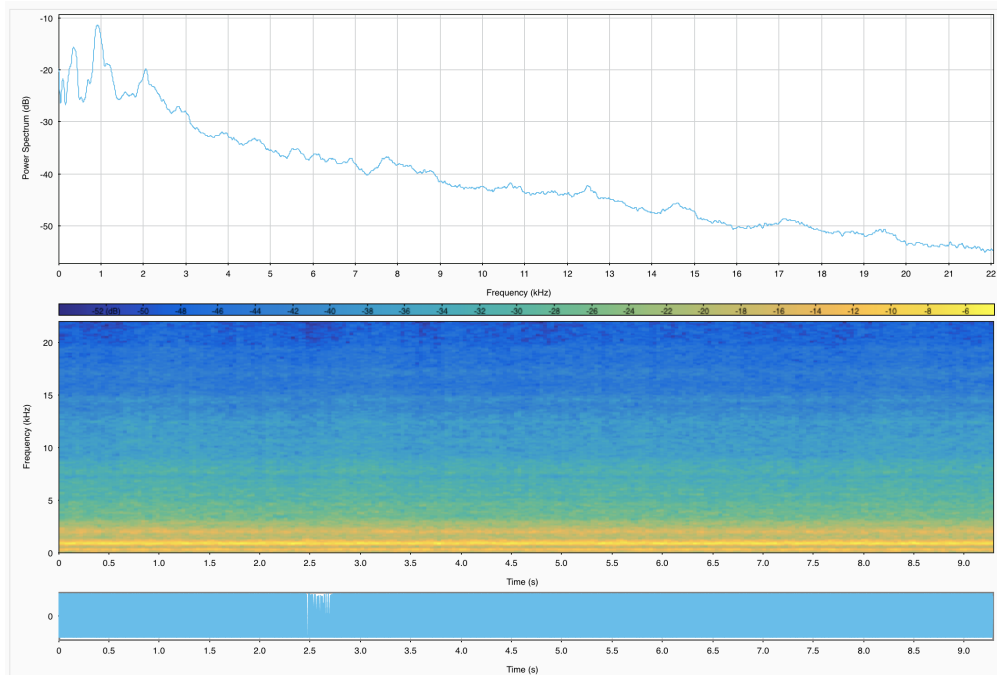

Figure 4.4: Recorded simulation at 0.5 m, in Matlab Signal Analyzer.

The fact that the sizes of the two leakages were not quantified makes it hard to compare them accurately. However, they were made as similar as possible in terms of the hearable sound for the professionals turning the valves.

4.1.1 CONCLUSION

The conclusion of the test is that it is possible to clearly distinguish when the sonar is close to a leakage and when it is not. We can also conclude that 156.3 m is too far to detect a typical leakage for the sonar.

4.2 DISTANCE MEASUREMENT IN POOL

The aim of this test was to determine if the full system was able to measure distances under water, as well as become familiar with the characteristics of the pinger pulse and how it was received by the sonar. This knowledge was also used to develop a script to calculate distances from the recorded files. The test was performed in an inside pool with freshwater.

The pool was approximately 10 m long, 5 m wide, and 3 m deep. The tests were performed at distances of 8.55 m and 2.54 m at a depth of approximately 0.5 m.

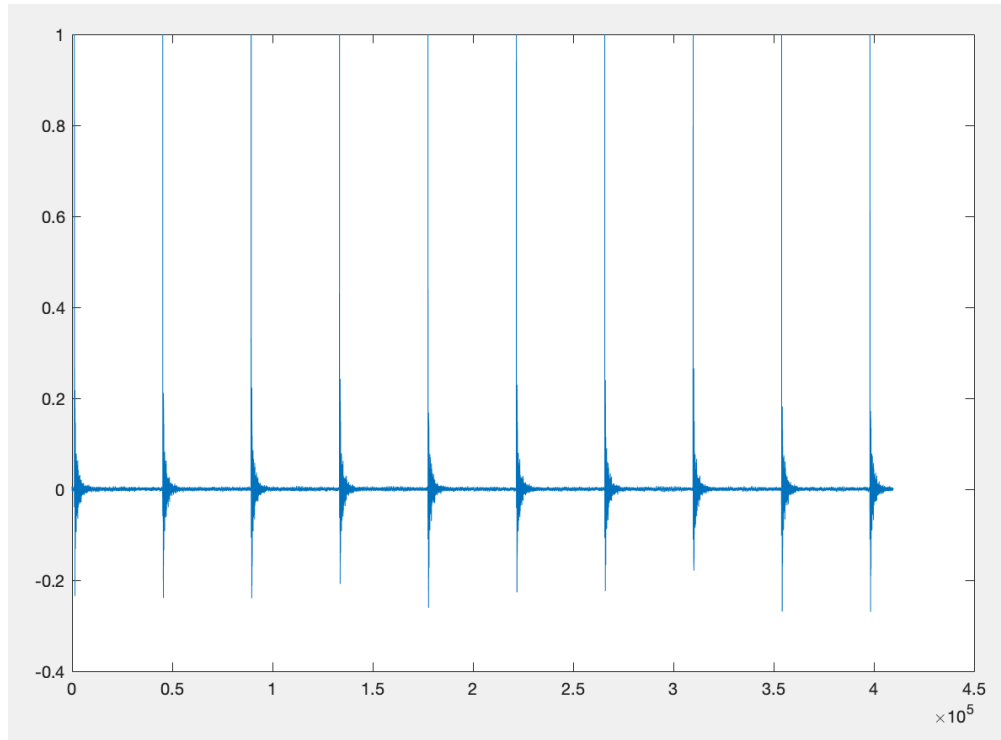

Figure 4.5: Recording from distance measurement test at 8.55 m with a V_{out} of 2V.

In figure 4.5, approximately nine seconds of the recording from the test can be seen. The y-axis is the digital value of where 1 is 230 mV, and the x-axis is the samples. The sudden increase in amplitude every 4410 samples is the sonar's local GPS time-stamping.

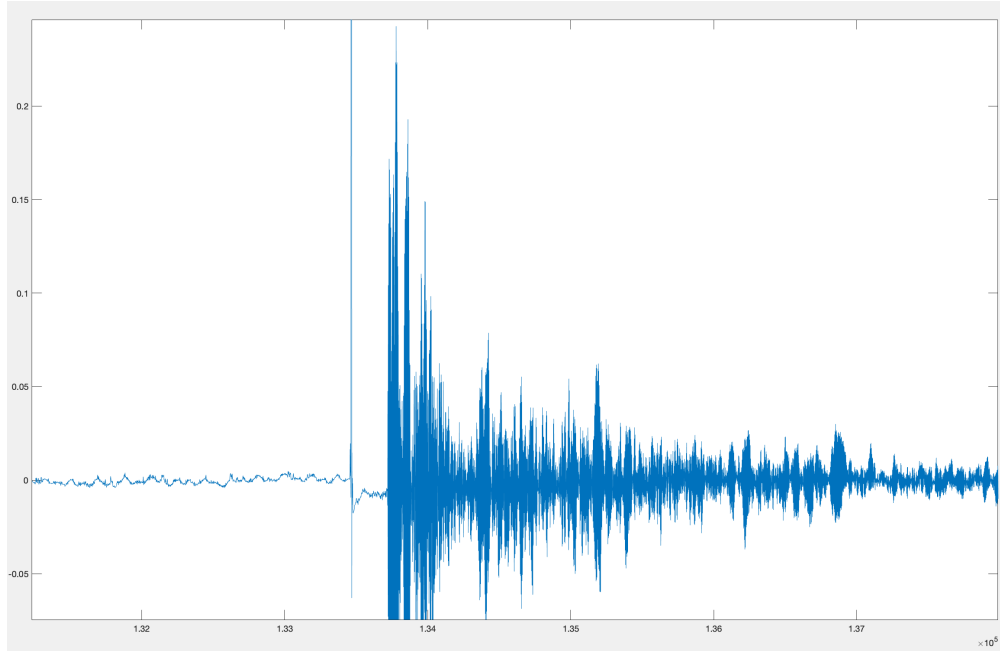

Figure 4.6: Section of recording from distance measurement test at 8.55 m with a V_{out} of 2V.

A closer look at one of the time-stamps in figure 4.6 reveals a gap between the time-stamp and a different signal. The signal after the gaps is the pulse from pinger. Calculating the difference in time of the time-stamp and the onset of the pinger-pulse gives the distance between the two units, given that the GPSes are in sync. A screenshot of the file in Matlab Signal Analyser tool is added for later comparison in figure 4.7.

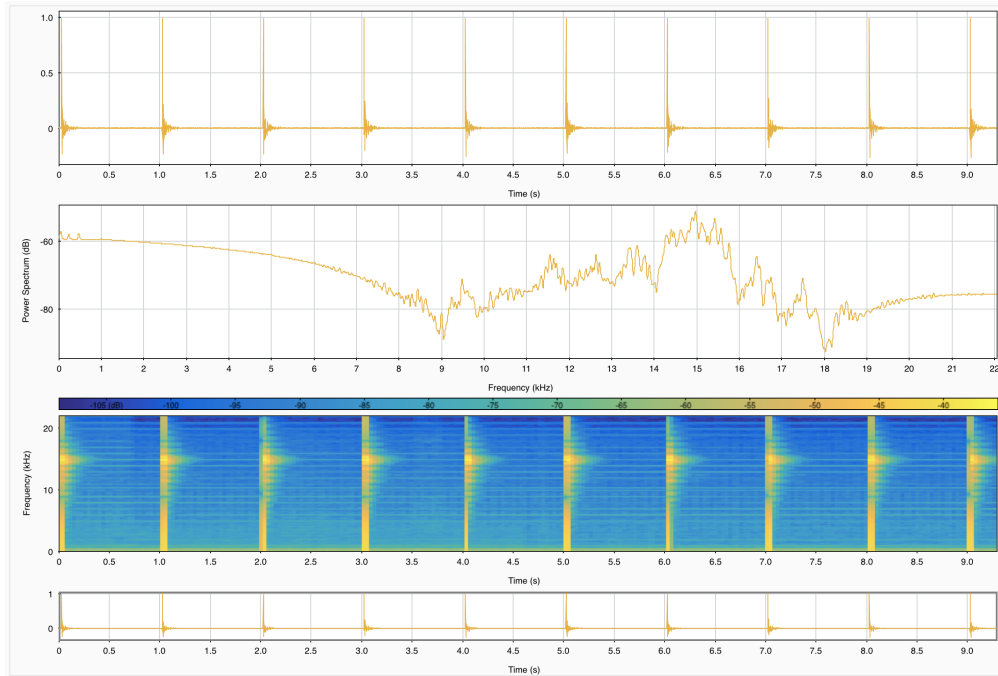

Figure 4.7: Recording from distance measurement test at 8.55 m with a V_{out} of 2V in Matlabs Signal Analyzer tool.

4.2.1 DISTANCE MEASUREMENT SCRIPT

To quicker post-process a high number of recordings from this test, a simple script was made. The script extracts the most relevant information from the files, such as the amplitude of the pinger pulse and calculates the distance.

The script first extracts channel one from the .wav file and creates variables of known data such as sample rate and speed of sound. The script then creates a vector to hold the sample numbers of all the time-stamps from local GPS. Then it counts the number of samples to the onset of the pinger pulse, and calculates the average. The measured distance is calculated from the average, and a while-loop goes through the file to find the highest amplitude, that is not from the time-stamp. A plot of channel one is also generated so that the user may quickly determine the validity of the output of the script. The full script can be found in appendix B.

4.2.2 CONCLUSION

From this test, we have learned that the system is capable of performing more than sufficiently accurate measurements under water. The signal strengths measured at different distances also indicate that the prototype will be able to measure distances up to at least 4 km. The calculation of this figure can be seen in section 2.10.

Filename	Signal strength V_{out} [V]	Distance [m]	Measured [m]	Amplitude of pulse
1VLangAvs.wav	1,0	8,55	8,5375	0,1598
2VLangAvs.wav	2,0	8,55	8,5541	0,2234
4VLangAvs.wav	4,0	8,55	8,5560	0,3799
1VLangAvstand.wav	1,0	8,55	8,5409	0,1174
HalvVOLTLangAvstand	0,5	8,55	8,5818	0,05289
Avstandsmåling16031V	1,0	2,52	2,5247	0,4563
Avstandsmåling16062V	2,0	2,52	2,4730	0,6283

Figure 4.8: The results of measurements with different V_{out} and distances.

The results in figure 4.8 indicates that the prototype have a sufficient accuracy, at least at short ranges relative to the use case. The received signal amplitudes makes sense based on signal strength and known theory.

4.3 DISTANCE MEASUREMENT IN ACTUAL PIPE-NETWORK ENVIRONMENT

The two previous tests have shown that the integrated prototype can detect realistic leakages and that it can measure the distance between the pinger and the sonar under water with high accuracy. With the aim to determine if the prototype could do measurements in the actual environment the concept is intended for and learn more of how the pinger pulse traversed an actual pipe, we were able to perform a test at a pipe-stretch in the Trondheim water distribution network. The pressure and the temperature in the pipe on the test day were 7.3 bar and 3.5 °C, respectively. The material of the pipe is polyethylene, and it has an inner diameter of 184 mm.

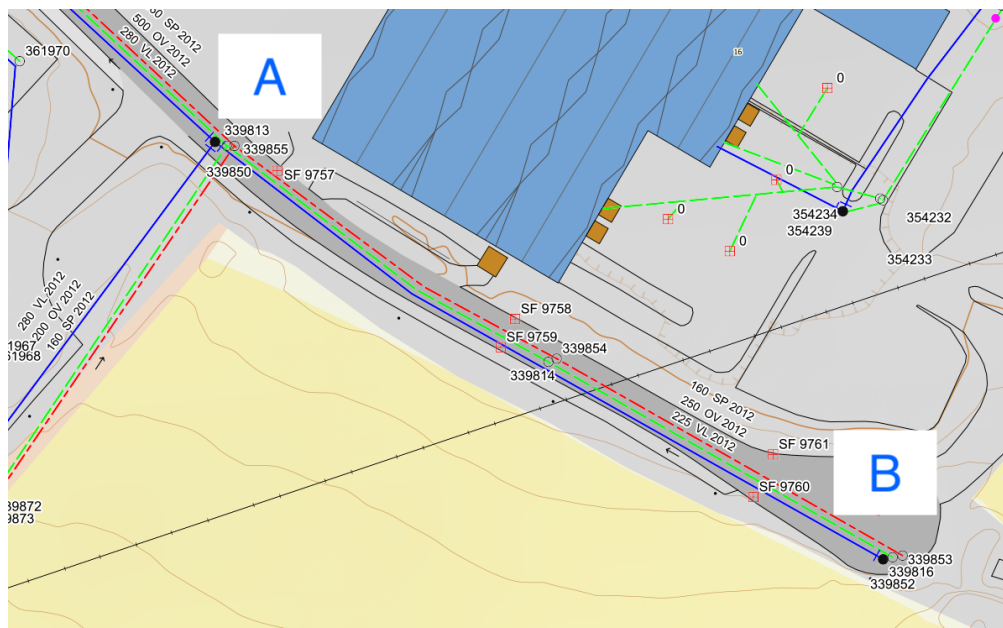

Figure 4.9: Overview map of the test site provided by Trondheim Vann og Avløp.

An overview map of the test site can be seen in figure 4.9. The manhole at point A is where the pinger was mounted, and the sonar was put inside the pipe in point B. The blue

line represents the freshwater pipe we were testing in. Note the slight bend in the pipe stretch between point A and B, which will be commented in the discussion.

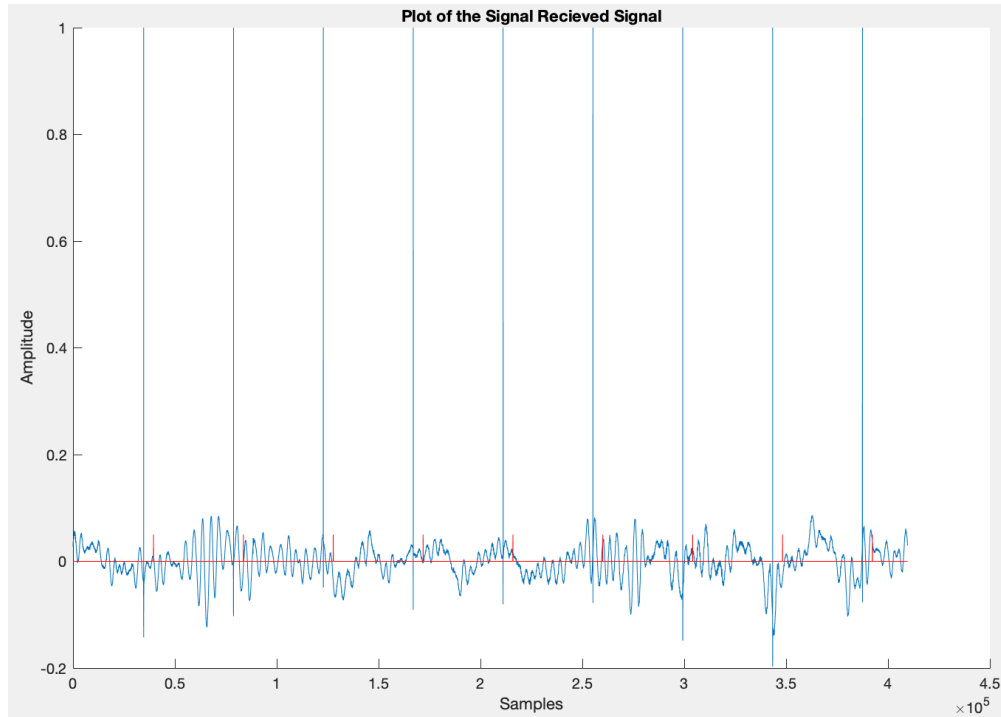

Figure 4.10: Approximately 9.5 seconds of recording by the sonar with no simulated leakages. Red lines show expected time of pinger signal which is calculated below.

In figure 4.10 a recording from the test can be seen, and at first glance, there is no apparent trace of the pinger pulse. To further investigate the data, we start by calculating when the pinger signal is expected. At 3.5°C and 7.3 bar, the speed of sound in freshwater is about 1420 m/s. Then the expected sample numbers of the pinger signals can be calculated as follows.

$$t_{ping} = t_{local} + \frac{156.3m}{1420m/s} = t_{local} + 0.11s \quad (14)$$

The following calculation converts the time values to specific samples with the sampling frequency f_s of 44100 Hz.

$$s_{ping} = s_{local} + 0.11s * 44100Hz = s_{local} + 4851samples \quad (15)$$

The results of this equation are illustrated by the vertical red lines in figure 4.10 with an arbitrary amplitude of 0.05.

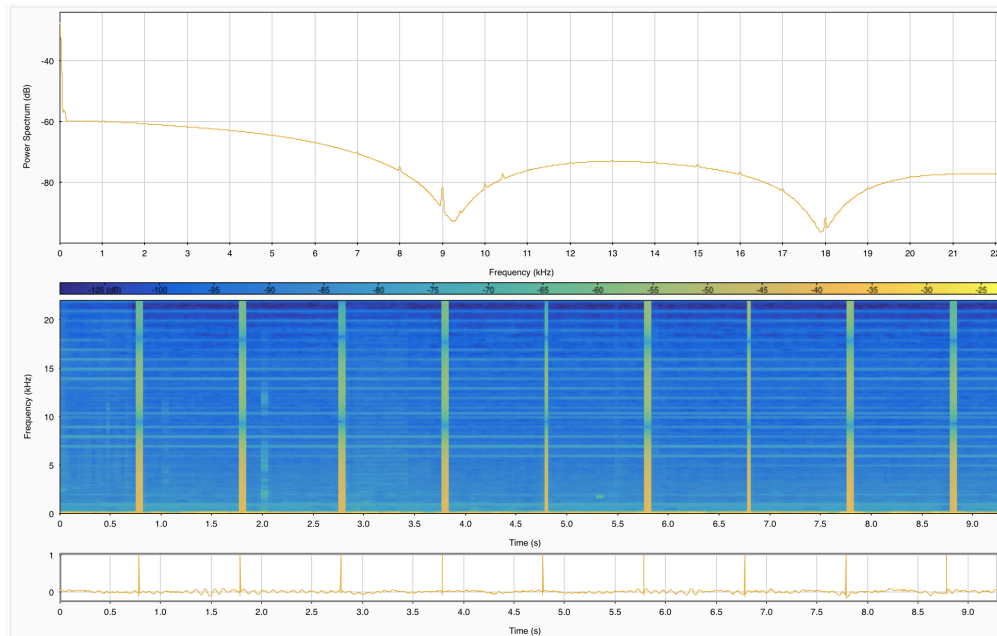

Figure 4.11: Matlabs Signal Analyzer

In figure 4.11, a screenshot from the Matlab Signal Analyzer can be seen. There are no apparent signs of the 15kHz signal here either. The characteristics seen in figure 4.7 can not be identified in figure 4.11. At approximately 2 seconds, there is a noise with a wide range of frequencies. The length, frequencies, inconsistency and timing, of the noise do not match the pinger pulse, so it is ruled out to be an arbitrary noise of which there are several in the different recordings. We cannot identify any signs of the pinger-pulse in both figure 4.10 and figure 4.11.

4.3.1 DATA OVERLAY

A data overlay was created to show what an expected received signal would look like in the signal analysis tools used above. The constructed data overlay is a 15kHz pulse at the expected points in time with a length of 1 ms. The amplitude of the data overlay is set to 0.04228, which is 10 % of expected amplitude from equation 14 with the used parameters on the test day.

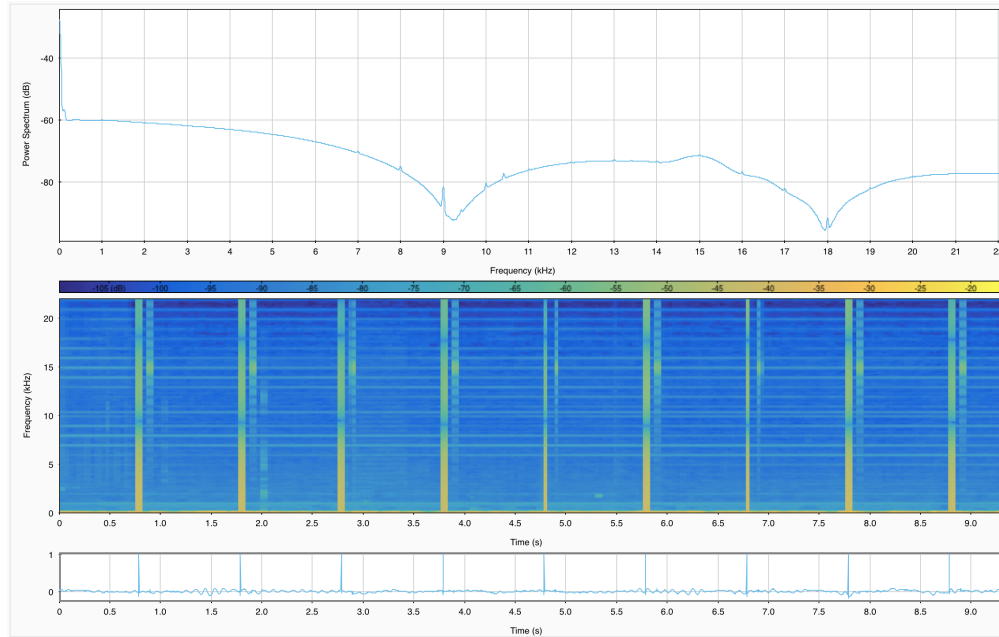

Figure 4.12: Matlabs Signal Analyzer with a data overlay.

4.3.2 CONCLUSION

When comparing figures 4.11 and 4.12, it can be seen that the data overlay is clearly visible with our analysis tool, and that there are no indication of a similar signal in figure 4.11. This leads us to the conclusion that pinger-pulse is not recorded with the sonar in a way that we can observe. A variety of different pulse-configurations were used through the test with an equal result. There is no obvious reason why the pulse is not there since the subsystems work separately as well as integrated into a similar environment.

4.4 SUMMARY OF INTEGRATION TESTING AND RESULTS

With three integration tests we have been able to measure the two key variables and answer the research questions of this master thesis, while we have uncovered a new important question. The tests confirm that with a low-cost self-made audio sensor, it is possible to measure a water pipe leakage, and measure distance with acoustic time-of-flight with a satisfying theoretical range and accuracy. Results from measuring distance at 8.55 m in a pool, indicate a theoretical range of 4.4 km, but the prototype have no valid measurements at 156.3 m in the actual pipe-network environment. This generates the question of what the key difference between these environments for our prototype is. This will be further commented in the discussion.

5 PAPER SUBMITTED TO THE NORDDESIGN 2020 CONFERENCE

5.1 THE SUBMITTED PAPER

Based on insight gained from building the prototype and testing it in different environments during this project, a paper was produced. The paper considers the application field of testing a prototype in prototyped test environments versus in the actual intended environment. The paper has been submitted to the NordDesign 2020 conference, and can be found on the next page. The authors are Johan Christian Wigen Hjorth, Heikki Sjöman and Martin Steinert.

NordDesign 2020
August 11-14, 2020
Kgs. Lyngby, Denmark

The Crux of Integration Prototyping in Complex Environments

A case study of integration prototyping with a low-cost sonar leakage system

Johan Chr. W. Hjorth¹, Heikki Sjöman¹, Martin Steinert¹

*¹Norwegian University of Science and Technology (NTNU)
Department of Mechanical and Industrial Engineering (MTP)
jchjorth@stud.ntnu.no
heikki.sjoman@ntnu.no
martin.steinert@ntnu.no*

Abstract

This paper considers the application field of testing a prototype in prototyped test environments versus in the actual intended environment. This is done by studying a project with the aim of developing a new low-cost concept to locate water pipe leakages. The concept lets a passive sonar flow in the water stream in a pipe, and measures the distance traveled with a pinger positioned at a known point. The pipe network is defined as a complex environment in that it is inaccessible, except for professionals with special training. The two key variables in this concept that together determine a leakage's location are the distance from the start point to the sonar, and the sound pressure level (SPL) ambient to the sonar. Wayfaring with a bias toward building and testing have been used within a framework of engineering design. Three subsystems were designed, built, and tested separately to meet individual requirements set from the start, as well as emerging requirements (Kriesi, Blindheim, Bjelland, & Steinert, 2016). When the individual requirements were met, the subsystems were integrated into more relevant test environments. The final prototype has been tested to be able to measure the two key variables. Although the distance measurement is accurate and has a sufficient range in an underwater environment, the results are not equal when tested in the real pipe-system. We wanted to share a snapshot of our system in a realistic development case before taking the project further illustrating the real problems developers face during projects. A focus on prototyping test environments with the aim to test the solution's performance to different specific variables of the intended environment may have been an efficient way to capture the knowledge necessary to develop a successful solution. However, we argue that in order to unveil what relevant attributes that are different between a test environment and the intended environment to our solution, one must test the solution in the actual environment as well. We therefore, suggest alternating approach of testing in the intended environment and prototyped test environments. This paper illustrates the value of developing prototypes with a low resolution so that critical variables of the problem and solution space, and other negative consequences, can be illuminated, with a minimum amount of time and resources.

Keywords: *Product Development, Prototyping, Integration, Leakage-detection, Sonar, Test Environments*

1 Introduction

In this paper we will describe on our experience with the relationship between prototyping test setups to fit specific test variable as (Winjum, Wulvik, Erichsen, Welo, & Steinert, 2017 Welo, & Steinert, 2017) suggests, and comparing the results with integrated testing in the actual environment. The emerged opportunity from this study was to understand how to find the variables that play the key role in development process when prototyping for complex environments and what of this can be generalized. We do this by analyzing a real-life development project done by authors in our development laboratory resolving a need from the industry:

In 2017 a report (Norsk Vann, 2017) on the quality of the 81 Norwegian municipalities' water and sewage systems was published. Out of the 81 participating municipalities, 9 % have a water loss of less than 20 %, and 40 % of the municipalities have a water loss higher than 40 %. Leakages may also cause drops in pressure, which again may cause contaminants to enter the distribution network. Contaminated water can be dangerous and may cause sickness and even death. This is not sustainable in terms of health, environment, or economy. Many of the techniques used to locate leakages today are based on the iron pipes' acoustic abilities, which is less effective when handling newer polymer pipes that are implemented today. In this development project, we have aimed to develop a new low-cost method to locate leakages in water pipes. The research questions for the project are as follows:

- May we observe water pipe leakages with a low-cost self-made audio sensor?
- Is measuring the distance with acoustic time-of-flight a possible solution with low-cost equipment?
- If so, is the accuracy and range of the solution satisfactory?

1.1 Concept

From a pre-project where several ways of measuring distances underwater in low-cost manners were explored, a concept that could be applied in locating leakages emerged. Our solution is to measure the mechanical waves that propagate through the liquid as a result of a leakage in the pressurized pipe. Instead of statically detect leakages with hydrophones or microphones, a hydrophone is put inside the cold (3.5 °C) and pressurized (7.3 bar) pipe. By letting the water carry the sonar through the pipeline, long stretches of the pipeline may be inspected effectively, and leakages, as well as other data, may be detected accurately (< 1 meter). We benchmarked a similar solution, that uses a different measuring principle for determining the location of leakages (Pure, 2020). The overview of our concept is illustrated in the Figure 1.1.

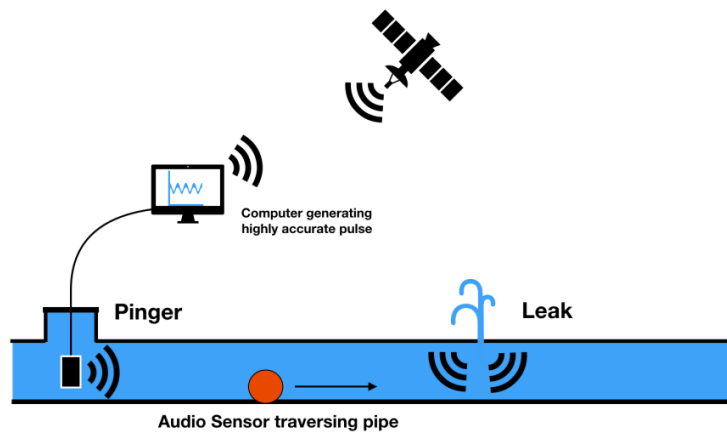

Figure 1.1

One of the biggest challenges with this concept is not to detect leakages but the ability to determine the location of the sonar at the point in time the leak was detected. We have solved this by having a pulse sent out from the start position with very accurate rhythm. By knowing the speed of sound in the medium as well as the point in time, the signal is emitted and received, the distance between the pinger and the sensor package can be calculated.

2 Method

In this project, we have used a framework of Engineering design by (Pahl & Beitz, 2013). Having a clear vision of how the concept should materialize, the system and subsystems have been designed and tested to meet requirements set from the start. This has been followed by more complex tests, testing the integrated system as a whole, which has generated emerging requirements.

Within this framework, an exploratory approach with an emphasis on testing to learn has been used to gain knowledge of problem space and concept at hand, namely, the Wayfaring Method that was described by (Gerstenberg, Sjöman, Reime, Abrahamsson, & Steinert, 2015; Abrahamsson, & Steinert, 2015), which again was based on the Hunter-Gatherer Model introduced by (Steinert & Leifer, 2012). This method can be visualized as a map where the end-point changes as the path is explored along the way, as an analogy to the old wayfaring way of traveling. The direction of where to go next is guided by gained knowledge from newly probed ideas. By building rapid prototypes and testing them in design-build-test cycles, ideally, a team with a diverse skill set probes the solution space. The aim of these prototypes is to rapidly learn more about their current surroundings in the solution space, but it is not to make perfect solutions. Letting insights guide the product developer through the solution space in this way can lead you to unexpected twists and turns, which may help you uncover 'the big next idea' and find unknown unknowns as referred to by (Gerstenberg et al., 2015; Sutcliffe & Sawyer, 2013). As one learns more about the problem and possible solutions through this journey, one can, in addition, set dynamic requirements. (Kriesi et al., 2016 & Steinert, 2016) propose that this way of letting the insights from exploring to set a part of the requirements may generate more radical and innovative solutions

The design approach used in this project have been of an exploratory nature, where prototyping leads the way within the framework of engineering design (Schrage, 1996). With a strong bias toward building and testing, knowledge and insights about the problem and solutions have been acquired (Schón, 1983). The set-based mindset will also be a part of the overall approach with prototypes that allow separate building and testing of subsections and configurations (Kennedy, Sobek, & Kennedy, 2014).

3 Development path

Through interviewing Trondheim Vann og Avløp a clear requirement for a leakage detection tool was formulated as follows: The low-cost system must be able to identify leaks in 6" wide and polyethylene pipe stretches with at least 1 m accuracy. To meet these requirements with our concept, sets of start-requirements were set for the different subsystems. The different modules were designed built and tested concurrently. The start-requirements for the three different modules are listed below, with a quick description of the development, followed by requirements for the integrated system. It was chosen to divide into these subsystems because they in themselves had clear requirements that would have to be met individually. It was, therefore, effective to develop and test them concurrently.

3.1 Sonar Transducer requirements:

Main requirement: The Sonar Transducer needs to be sensitive enough to detect leakages and pinger pulses while carrying all electronics in a robust and watertight way.

- It must be able to register relevant frequencies from leakages and pinger
- It must be able to contain all required electronics for the sonar physically.
- It needs to be able to roll in all three axes inside a 6" pipe.
- It must be e watertight at least at 10 bar.
- It must have a total higher density than ambient water so that it will sink in water.
- The noise created from motion cannot saturate the transducer.

The sonar transducer was created from the ground up in this project. An aluminum cylinder was lathed to a thin shell with a welded lid in the bottom. On the outside of the cylinder, five ceramic rings that vibrate radially when subjected to sound were mounted with connected wires. The cylinder was then cast in epoxy, and a PVC lid was lathed. The transducer with the lid was tested to be watertight in a pressure chamber at 20 bar. To map the sensitivity of the transducer do different frequencies and determine its receiving sensitivity at relevant frequencies, it was tested and analyzed. Through testing, it was found that it met all the start requirements.

3.2 Sonar Electronics requirements:

Main requirement: The Sonar Electronics needs to be able to record all relevant data for the duration of an inspection.

- It needs to fit inside the sonar Transducer.
- It needs to record autonomously for at least three hours.
 - It cannot overheat in three hours
 - Battery life needs to be at least three hours
 - File-size and storage capacity needs to fit three hours of recording
- The data needs to be stored in such a way that it is possible to calculate distance accurately from it.
- Abrupted loss of power or other malfunctions should compromise as little recorded data as possible.

- It needs to record an accurate time-pulse from a GPS and record signals from the transducer simultaneously.
- The GPS needs to be able to be synchronized before and after entering the pipe.
- Needs to amplify signals from transducer if necessary.

To record and store the data from the transducer, a Raspberry Pi 3 A+ was used to. A circuit to amplify the signal from the transducer was also made. A battery from a power-bank was used as a power source for the electronics, and a Ublox LEA M8T was used as the GPS unit. To convert the analog signal to digital, an Xrtyfy SC1 soundcard with one channel was used. The recording script, parameters such as GPS-ping and the physical layout of the circuit, was developed iteratively as our knowledge grew through testing.

3.3 Pinger Requirements:

Main requirement: The Pinger needs to emit an accurate pulse that reaches the sonar in a pipe.

- Needs to be able to emit a mechanical pulse through at least 150 m in water.
 - The frequency of pulse needs to make sense in terms of pipe dimension and transducer.
 - The amplitude of the pulse needs to be amplified to a necessary degree.
- The pinger needs to communicate with satellites to ensure accurate triggering of the pulses.
- The pinger needs to be firmly mounted inside the pipe at the center of the pipe cross-section.
- The pipe mount needs to be watertight at 10 bar and let a cable go from the inside to the outside.
- The resolution distance measurement needs to be at least 1 m with the sonar moving at 1m/s.

For the pinger a transducer with unknown parameters was provided by Norbit. To map the sensitivity of the transducer, do different frequencies and determine its transmitting sensitivity at relevant frequencies, it was tested and analyzed. The main resonance frequency of the transducer was found to be 15kHz. The mount was constructed from the ground and was fixed to a lid used in pipe armature in Trondheim Kommune. The pinger was tested to be watertight at 20 bar in a pressure chamber. An Analog Discovery 2 was used to generate desired pulses, and the scope was used for diagnostics of the whole prototype. A typical amplifier for sound-systems in cars was used to amplify the signal as well as a transformer. A Ublox LEA M8T GPS unit was used in this module as well to trigger the pulse generator.

3.4 Integrated requirements:

- The sonar needs to detect leakages from inside of the water distribution network. (Leakage Test)
- It must be possible to derive the distance between the pinger and the sonar accurately underwater from the gathered data. (Under Water Distance Measurement Test)
- The pinger needs to emit a pulse that reaches the sonar through a pipe stretch in the water distribution network. (Under Water Distance Measurement Test in Actual Environment)

4 Integration Tests

4.1 Leakage Test

To test if the sonar was able to detect leakages, the sonar was put in water filled pipes with 3.5 degree C and 7.3 bar. Leakages was simulated by opening a valve to release a tiny flow of

water from the system resulting in the sound signature of a typical leakage. This is the way the professionals simulate leakages when they are training.

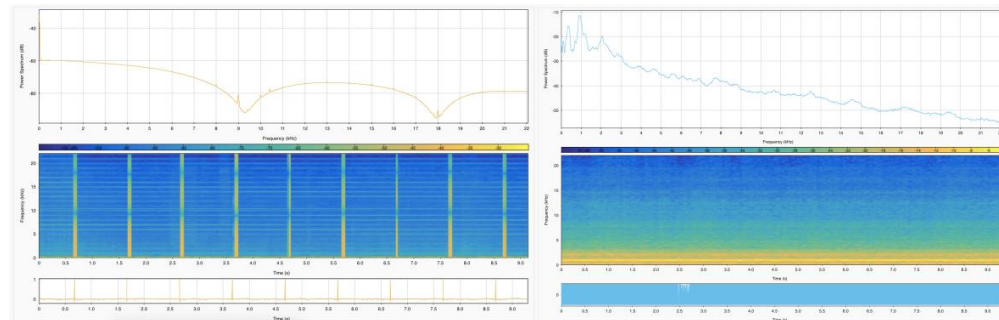

Figure 4.1

Figure 4.2

In figure 4.1 a screenshot from the Matlab Signal Analyzer can be seen. The bottom part displays the whole signal in the time domain. The top part show the power spectrum in the frequency domain. It displays the amount each frequency from zero to 22050 Hz is represented on average for the chosen time section of the signal, which in this case is approximately nine seconds. The section in the middle is a combination of the one at the top and the one at the bottom. Time is on the x-axis, frequency is on the y-axis and the intensity at a small section in time is represented by color.

In figure 4.2 the recording of the simulated leakage at 0.5 m in the Matlab Signal Analyzer tool can be seen. Compared to figure 4.1, an obvious increase in amplitude across the whole time sequence can be observed. The lower frequencies increase the most. When listening to them with the human ear, one can easily distinguish them, and professionals recognize the sound as a definite leakage. The signals are off the scales which means that the sonar-transducer is saturated and that the amplitude of the alternating pressure is more than 1.2kPa. Theoretically this means that we should be able to detect the leakages more than 3.5 m away.

A leakage was also simulated at 156.3 m, but no recognizable signal was recorded by the sonar. The conclusion of the test is that it is possible to clearly distinguish when the sonar is close to a leakage and when it is not. We can also conclude that 156.3 m is too far to detect a typical leakage for the sonar.

4.2 Under Water Distance Measurement Test

The aim of this test was to determine if the full system was able to measure distances under water, as well as become familiar with the characteristics of the pinger pulse and how it was received by the sonar. This knowledge used to develop a script to calculate distances from the recorded files. This test was performed in an inside pool with fresh water. The pool was approximately 10 m long, 5 m wide and 3 m deep, and the tests were performed at distances of 8.55 m and 2.54 m, and the depth of approximately 0.5 m.

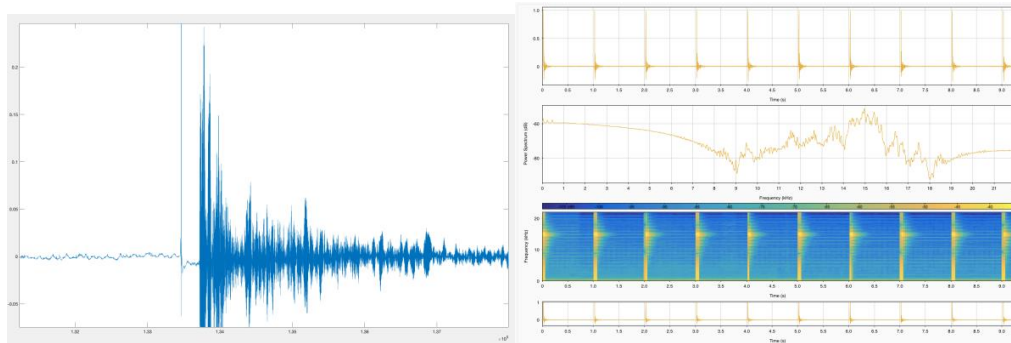

Figure 2.3

Figure 4.4

In figure 4.3 a closer look at one of the recorded pinger-pulses can be seen. The y-axis is the digital value of where 1 is 230mV, and the x-axis is the sample number. The first amplitude spike from the left is the GPS in the sonar giving setting a timestamp. After a small gap a different signal with a high amplitude is recorded. This is the pinger-pulse reaching the sonar followed by different echoes from the pool. Calculating the difference in time of the timestamp and the onset of the pinger-pulse gives the distance between the two units, given that the GPSes are in sync and the speed of sound in the medium is known.

In figure 4.4 the recording can be seen in Matlabs Signal Analyser tool. One can clearly see the presents of the 15kHz pinger pulse in the recording. From this test we have learned that the system is capable of performing more than sufficiently accurate measurements under water. The signal strengths measured at different distances also indicates that the prototype will be able to measure longer distances such up to at least 4 km assuming that the signal decreases with $1/R$. The results of the different measurements are listed below.

Filename	Signal strength Vout [V]	Distance [m]	Measured [m]	Amplitude of pulse
1VLangAvs.wav	1,0	8,55	8,5375	0,1598
2VLangAvs.wav	2,0	8,55	8,5541	0,2234
4VLangAvs.wav	4,0	8,55	8,5560	0,3799
1VLangAvstand.wav	1,0	8,55	8,5409	0,1174
HalvVoltLangAvstand	0,5	8,55	8,5818	0,05289
Avstandsmåling16031V	1,0	2,52	2,5247	0,4563
Avstandsmåling16062V	2,0	2,52	2,4730	0,6283

4.3 Under Water Distance Measurement Test in actual Environment

With the aim to determine if the prototype could do measurements in the actual environment the concept is intended for, and learn more of how the pinger pulse traversed an actual pipe, we were able to perform a test at a pipe-strech in the Trondheim water distribution network. The pressure and temperature in the pipe on the test day was 7.3 bar and 3.5 degrees Celsius respectively. The material of the pipe is polyethylene and it has diameter of 200 mm.

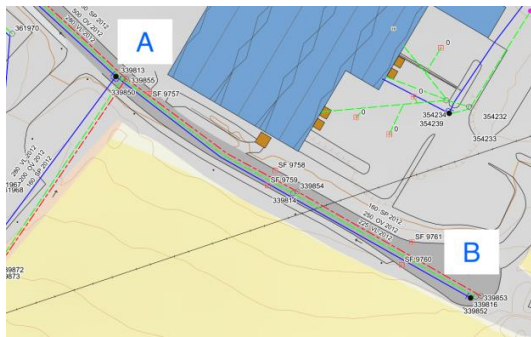

Figure 4.5

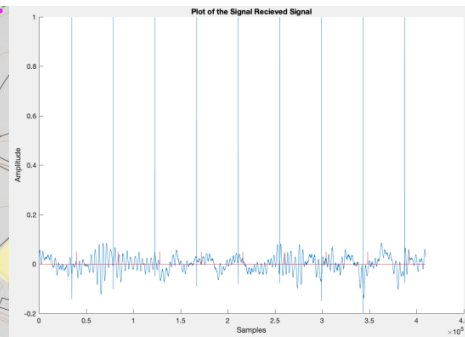

Figure 4.6

An overview map of the test site can be seen in figure 4.5. The manhole at point A is where the pinger was mounted, and the sonar was put inside the pipe in point B. The blue line represents the fresh water pipe we were testing in.

In figure 4.6 approximately 9 seconds of the recording from the sonar is plotted in blue. At first glance there is no apparent trace of the pinger pulse. To further investigate the data we start by calculating when the pinger signal is expected. At 3.5 degrees C and 7.3 bar, the speed of sound in fresh water is about 1420 m/s. Then the expected sample numbers of the pinger signals can be calculated. The results of these calculations are illustrated by the vertical red lines in the figure with an arbitrary amplitude of 0.05. There is no obvious systematic spike in the recording when it is expected.

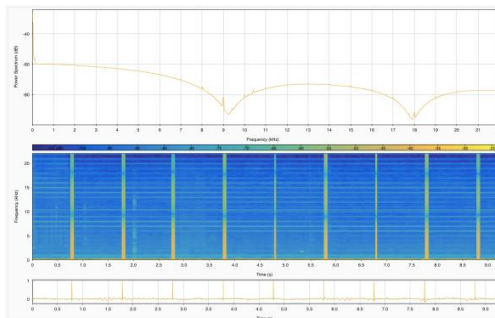

Figure 4.7

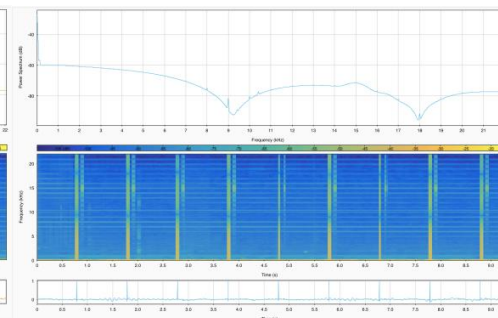

Figure 4.8

In figure 4.7 the recording can be seen in the Matlabs Signal analysis tool. There are no signs of the pinger pulse in the spectrogram or in the power spectrum. To visualize how a expected received pinger pulse would look like in this analysis a data overlay is created. The data overlay contains a 1 ms long 15kHz pulses with 10% of the theoretically expected amplitude. The recording with the data overlay in the Matlab Signal Analyzer tool can be seen in figure 4.8. At just 10 % of the expected amplitude with our parameters, the pulse is easily noticeable. This leads us to the conclusion that the pinger pulses is not received by the sonar for unknown reasons.

5 Results

From the start of this project a set of start requirements were set for the whole integrated system as well as the three subsystems. Every requirement was defined in such a way that a test would be able to confirm it was met or not. The three subsystems were developed in design-build-test cycles until they individually were able to meet the start requirements. This

was followed by tests of the subsystems working together or the system in its intended environment.

From the leakage test we have learned that the sonar is able to detect leakages in near vicinity in the environment for which it is intended. We have also learned that it cannot detect leakages 156.3 m away, which matches with professionals experience and does not affect the working principle of concept in a negative way.

From the distance measurement test we have learned that the integrated system is able to measure distances under water with a high accuracy. We have also learned that the waves sent out from the pinger have a high enough amplitude to theoretically reach a more than satisfactory distance.

From the distance measurement in the actual environment test we have discovered that although all the subsystems meet all requirement, and the integrated system work, there is unknown difference between the pool environment and the pipe environment that renders our prototype ineffective. One or several of our assumptions of the pipe environment have we found to be wrong.

6 Discussion

The test of the integrated system in its intended environment did not work. Through testing we have learned that all the subsystems work separately and that the system as whole work in the environment of a pool. As a logical result of this the system should also work in other environments given that there is no critical difference between the two. To find plausible error sources for the distance measurement in the water distribution network, we will elaborate some differences with this environment compared to the environment of the successful measurements. We will also reflect upon and map out assumptions made which may be wrong.

Differences between the water distribution network environment and pool environment.

- The distance of the measurement is 148 m greater.
- Pressure of the environment is 7.3 bar greater.
- The temperature of the environment 7 degrees C colder.
- The pulse has to traverse a polyethylene (PE) pipe with the inner dimension of 184.1 mm
- The trajectory of the sound wave is indirect to the sonar. The signal needs to adjust direction either by reflection (or guiding) due to the bend in the pipe.
- The power source for the amplifier for the pinger is a car battery.
- The time from when the system was turned on to when the valuable data was recorded was greater.
- The pinger was mounted in an armature.
- The sonar was put in an armature.
- The sonar was standing up-right, instead of hanging in a bag.

Assumptions made

- The differences above does not affect the system to such an extent that the pinger pulse will not reach the sonar.
- There are no significant acoustic barriers between point A and B.
- Sound pressure waves will decrease with a factor of 1/distance, and all other decreasing factors such as absorption are neglectable at this pressure, frequency, temperature, salinity and range.

Our main hypothesis is that the car battery could not deliver enough current to the amplifier which could not be checked with our oscilloscope, combined with a greater loss of sound pressure by the inevitable reflections in the pipe walls. Both these factors weakening the signal to such an extent that the sonar could register the signal. Testing our prototype integrated in the actual environment has given us an idea of which variables we should prioritize to test with prototyped test environments.

7 Conclusion

We have experienced that a prototype with every subsystem meeting its preset and emerged requirements, and that as whole proves to be working in the different relevant test environments, not necessarily works in the actual environment. This illustrates not only insufficient knowledge of the problem space, but also of how the integrated solution interacts with the problem space. We believe that prototyping test environments to fit specific test variables and testing in them would have given valuable knowledge of the problem space (Winjum et al., 2017). But we also believe that only testing how the prototype integrated in the actual environment would have given knowledge of what test variables that should be prioritized. Testing in the intended environment may reveal wrong assumptions and limited knowledge that prototyped test setups never can. This because both the prototyped solution and the prototyped test environment are made with the same foundation of knowledge and assumptions. We, therefore, suggest that the product developer should early-on actively alternate testing in the actual environment and prototyped test environments.

References

- Gerstenberg, A., Sjöman, H., Reime, T., Abrahamsson, P., & Steinert, M. (2015). *A Simultaneous, Multidisciplinary Development and Design Journey—Reflections on Prototyping*. Paper presented at the International Conference on Entertainment Computing.
- Kennedy, B. M., Sobek, D. K., & Kennedy, M. N. (2014). Reducing rework by applying set-based practices early in the systems engineering process. *Systems Engineering, 17*(3), 278-296.
- Kriesi, C., Blindheim, J., Bjelland, Ø., & Steinert, M. (2016). Creating dynamic requirements through iteratively prototyping critical functionalities. *Procedia CIRP, 50*, 790-795.
- Norsk Vann, B. (2017). *Tilstandsvurdering av kommunale vann- og avløpstjenester*. Retrieved from
- Pahl, G., & Beitz, W. (2013). *Engineering design: a systematic approach*: Springer Science & Business Media.
- Pure. (2020). SMARTBALL.
- Schón, D. (1983). *Ttu, Reflective Practitioner*. In: Nueva York, Basic Books.
- Schrage, M. (1996). *Cultures of prototyping*. In (pp. 191-205): ACM Press: New York.
- Steinert, M., & Leifer, L. J. (2012). 'Finding One's Way': Re-Discovering a Hunter-Gatherer Model based on Wayfaring. *International Journal of Engineering Education, 28*(2), 251.
- Sutcliffe, A., & Sawyer, P. (2013). *Requirements elicitation: Towards the unknown unknowns*. Paper presented at the 2013 21st IEEE International Requirements Engineering Conference (RE).
- Winjum, J., Wulvik, A., Erichsen, J. A., Welo, T., & Steinert, M. (2017). *A heuristic approach for early-stage product development in extreme environments*. Paper presented at the 2017 International Conference on Engineering, Technology and Innovation (ICE/ITMC).

6 DISCUSSION AND FUTURE WORK

6.1 RESULTS

Through this project, a low-cost way to locate water pipe leakages has been designed, built, and tested. It has been built with a satisfactory theoretical range and the ability to detect leakages. The prototype of the concept did, however, not perform with the same results when integrated into its intended environment. The most relevant features of the final integrated prototype are listed below.

Feature	Value
Weight of Sonar	1.13 kg
Able to roll in a 6" pipe	Yes
Can measure distance accurately	Yes
Operational Time	> 4 h
Extrapolated range in pool environment	130mm - 4.4 km
Range in intended environment	130mm - < 156.3m
Lowest observable SPL amplitude	12.1 Pa
Highest observable SPL amplitude	1.21 kPa
Distance measurement rate	1 Hz
Can detect leakages in pipes	Yes
Conclusion	Feasible

Figure 6.1: Summary of key features of the final integrated prototype.

6.2 POTENTIAL ERROR SOURCES

The final prototype was not able to perform a distance measurement of 156.3 when submerged in an actual pipe-network environment. Through testing, we have learned that all the subsystems work separately and that the system as whole work in the environment of a pool. As a logical result of this, the system should also work in other environments, given that there is no critical difference between them. To define plausible error sources for the distance measurement in pipe-network, we will list differences between the two environments and critical assumptions we have made. Further we will elaborate on two error sources we consider most likely.

Differences between the water distribution network environment and pool environment are listed below.

- The distance of the measurement is 148 m greater.
- Pressure of the environment is 7.3 bar greater.
- The temperature of the environment 7 ° C colder.
- The pulse has to traverse a polyethylene (PE) pipe with the inner dimension of 184.1 mm

- The trajectory of the sound wave is indirect to the sonar. The signal needs to adjust direction either by reflection (or guiding) due to the bend in the pipe.
- The power source for the amplifier for the pinger is a car battery.
- The time from when the system was turned on to when the valuable data was recorded was greater.
- The pinger was mounted in an armature.
- The sonar was put in an armature.
- The sonar was standing up-right, instead of hanging in a bag.

Critical assumptions made of the water distribution network are listed below.

- The differences above do not affect the system to such an extent that the pinger pulse will not reach the sonar.
- There are no other significant acoustic barriers between points A and B.
- Sound pressure waves will decrease with a factor of $1/\text{distance}$, and all other decreasing factors such as absorption are neglectable at this pressure, frequency, temperature, salinity, and range.

The pipe is relatively new and is made of PE, but the assumption that there is not a significant buildup of sediment, corrosion, or other acoustic barriers may be wrong. Our hypothesis is that the car battery could not deliver enough current to the amplifier, combined with a great loss of sound pressure by the reflections in the pipe walls.

6.2.1 LIMITED AMPLIFICATION OF PINGER SIGNAL

On the test day we were able to confirm with the human ear that the pinger-pulses was generated approximately when they was intended. The amplitude of the amplified signal, however, is unknown. In other tests, such as the pool tests, the amplifier has been supplied by the regular electrical grid transformed to 12 V, but on the integration test, the amplifier was supplied by a car battery with the car engine running. This was assumed sufficient because the amplifier is designed for cars and car sound systems. However, the amplifier may not be designed to amplify 5V signals.

This specific potential error source was identified because of the observation that the lights in the car flickered while the pinger was emitting pulses. It was especially noticeable when emitting longer pulses of 100ms or 500ms. The lights dimmed for the duration of the emission. This indicated to us that we may have pulled more current from the battery than it was able to supply. We were unable to measure the amplified signal on the test day, because of limitations on the used oscilloscope.

6.2.2 ABSORPTION BY REFLECTION

One hypothesis of why the signal did not reach the sonar may be that the pulse has been absorbed by the pipe walls. The map in figure 4.9 indicates that there is a bend in the pipe stretch. Trondheim Vann og Avløp does not have any specific data of the lengths before and after the bend, the angle of the bend, or even if the bend is there. If we make assumptions, we can do interesting napkin calculations.

If we assume that the map is correct, then approximately 1/3 of the pipe length is prior to the bend, and the bend can be measured to be approximately 8.5° . If we also assume that the sound pressure wave propagates in a straight line when it reaches the bend, using the inner diameter, we can calculate how many reflections the wave will have when traversing the remaining 100 m of the stretch.

Pipe-length until next reflection:

$$L_R = \frac{0.1841m}{\tan(8.5^\circ)} = 1.232m \quad (16)$$

The number of reflections before the end the pipe-stretch is reached:

$$n_R = \frac{100m}{1.232m} \approx 81 \quad (17)$$

Using equation 4 and the acoustical impedance of high density polyethylene $Z_2 = 2.33$ MRayl Selfridge (1985) and the acoustical impedance of water $Z_1 = 1.483$ MRayl Selfridge (1985). We get reflection coefficient of $R_s = 0.2221$. That means that the most direct pressure pulse with the theoretical maximal signal strength of 0.4228 would only need four reflections from the pipe walls to be decreased to a level of 0.0071, which is an unobservable level to the sonar.

In the calculations above, there are made many assumptions. Neither the incident wave or the reflected wave have a homogeneous direction in reality. They will radiate with a spread. The main angle of the incident and reflected wave will also not be identical. These effects may cause the most direct pressure wave to have a lower number of reflections than 81. The reflection coefficient is also calculated for an incident wave on a normal plane, which is not the case. In our opinion these results indicate that the absorption by reflection is a probable contributing error source, even if the number of reflections in reality is lower, and the reflection coefficient in reality is higher.

6.3 EMERGING REQUIREMENT AND KEY INSIGHTS

Throughout this project, we have tested a new low-cost way to locate leakages in water pipes. Exploring the solution space by wayfaring has given insight into useful limitations and requirements for the solution. We cannot possibly share all that we have learned from designing, building, and testing, but we will describe some of the key insights we have gained.

We have learned that there is an unknown critical difference between a pool and PE pipe in regards to an acoustical distance measurement. More testing is required to capture more knowledge of how sound traverse pipe bends and turns, how the pipe material effects the

wave range, and also how a pulse with a wavelength greater than the pipe diameter would perform compared to other wavelengths.

The sonar should store data continuously, to be more robust to abrupt power-downs, especially with this inaccessible and extreme test environment. The inaccessibility is leaving the researcher unable to survey the status of the sonar and intervene during the test. The extreme environment underwater with sudden changes in pressure and position may cause instability in a low-resolution prototype such as ours. We found that storing the data every 9 seconds or so is a sufficient way to mitigate the consequence of these possible instabilities.

It is not critical to have a two-channel sound card to separate the data. The initial design was to have a sound card with two audio in channels. One channel was to record time-stamps from internal GPS, and one was for recording sound. At the end of the project, we discovered that it was possible to limit the GPS time-stamp only to influence four samples every second. This data loss does not affect the practical performance of the system other than limiting minimal range to 13 cm. Measurements at similar and lower distances are, however, not relevant. Hence a sound card with one audio in channel is sufficient for our system.

Almost closing a valve to a high-pressure environment will lead to a sound similar to a leakage, fully closing it or closing it half-way will, however, not. This fact is important for three reasons. Old valves may be hard to close fully, thus leading to unexpected leakage sounds. Almost closing a valve is a way to simulate a leakages, which we exploit in this project. Sending the sonar through a network one is required to block branching pipes. Closing them half-way blocks the sonar from entering the branch while it allows water to flow through. This way one is able to perform tests on the network while it is fully operational.

It is not critical to have two antennas for this concept. We acquired two antennas for the system. One antenna is for the pinger to be connected constantly, and one smaller is for the sonar to use before entering the pipe and after exiting. We discovered when testing that the pinger is not needed to be operational while the sonar is not inside the pipe, thus eliminating the need for two antennas. However, antennas are low-cost, and it can be practical to have two if the sonar is to exit a long distance from the pinger.

6.4 CONCEPT

Given the results of this project, we suspect that this concept may be an effective tool, for instance, for professionals in Trondheim Vann og Avløp to locate leakages. Through the exploration of the problem space and solution space, we have also discovered important weaknesses with the concept.

One has to plan and control the trajectory of the sonar in an environment which may be hard and time-consuming to control. In urban areas, there is a new manhole every 100 m of pipe, with a split in three ways. To control the trajectory through a manhole, a professional will need to access the manhole and close two of the four valves half-way. Based on experience from testing, this may take a total of 10 minutes of physical labor. If one were to inspect a 1 km of pipe in such an area, professionals would need to do this at eight manholes.

Once the number of ways the sonar may flow is limited, one must also ensure that the direction is correct. This will typically be manipulated by opening a valve fully at one end.

This affects the water to flow in the intended direction, but one does not have full control of the direction or speed. One is also still vulnerable to other users using water at the other end of the network.

The findings of this project indicate the concept has potential but also that there are important unanswered questions that can break or limit the concept. Even if future findings determine the concept to be too vulnerable to, for instance, PE-pipes, we argue that the concept may be feasible for especially inspections of long pipe stretches of other more common materials.

6.5 METHOD

In this project, the Wayfaring Method Steinert & Leifer (2012) within a framework Engineering Design by Pahl & Beitz (2013) has been utilized. The Wayfaring Method has been used to uncover the path and adjust dynamic requirements, while an end-point of the concept have been envisioned and planned for, from the beginning. Emerging requirements have been discovered through designing, building and testing.

6.5.1 PROTOTYPING TEST ENVIRONMENT

One of the main challenges with this project has been the inaccessible test environment. The prototype has had a minimum range of ~ 150 m through the duration of the project until the final iteration. This was caused by a one channeled sonar with a 100 ms blind spot every second. Having this minimum range between the pinger and sonar gave a constraint to test environments to have a greater length than 150 m, which we suspect increased the threshold for performing range testing, and in retrospect other relevant tests as well.

We could have been more active in prototyping test environments as Winjum et al. (2017) suggest. We could have prototyped different test environments to more easily isolate test variables and increase the accessibility of different test variables. There are great amounts of knowledge we could have captured performing tests within the minimum range. Not measuring distance but capturing the response of a pinger pulse traversing, for instance, pipes of different dimensions, materials, and bend varieties. We suspect that this approach would have given us more data in a shorter time because of the increased accessibility. We also suspect that the knowledge captured would be more relevant and precise, because we would have greater control over all variables.

Even though the pipe distribution network represents a highly relevant environment, it also has other important limitations apart from inaccessibility in regards to testing. There are many uncertainties of how the pipe section actually is built in terms of valves, bends, and forks. In terms of distance measurement, it is also complicated to control measurements with a reliable secondary measurement. To isolate variables, in general, may also be difficult.

We do not advocate that one should not test in the actual environment of which the prototype is intended, but in our opinion our project illustrates that this form of testing also has a limited application field. This, we suspect, may be well supplemented by prototype test setups.

6.5.2 DESIGN FIXATION

From the early stages of this project, we had a clear vision of how the concept should be, and to some extent, how the prototype should perform. This has given us an advantageous focus on work that generates knowledge we can use directly in developing the solution. This may have, however, also made us somewhat blind in certain areas.

A critical function of the sonar is that it is able to record both the time-stamp from its internal GPS, as well as the pinger-pulse accurately and simultaneously. This led us to the design choice of having a sound card with two audio-in channels so that these two signals could be recorded independently and synchronized. Low-cost sound cards with a small form factor, do exist on the consumer market, but they are harder to acquire than the ones with one channel. Information on the number of channels and regular data-sheets on the sound cards were surprisingly hard to acquire, resulting in direct contact with suppliers. This communication was slow, and the information gained was, in some cases, even wrong. This led us to purchase a two-channel sound card on first-hand information from a reliable supplier, only to find that, in fact, it was only one.

We used approximately two weeks to find a low-cost two-channel sound card from a reliable supplier with correct product information. The product was only to be shipped from Great Britain to Norway so we ordered it in the hopes that shipping would be quick. They used five weeks in shipping. Seven weeks was used in total to acquire a low-cost two-channel audio card. Unfortunately, the form-factor of the sound card was different from what we had ordered. The difference was subtle but critical to our limited space. This led us to alter the sound-card by removing covers and rearranging wires.

The result was a two-channel sound card with an adequate form factor that functioned sometimes. It was not always visible to the computer it was connected to. This instability resulted in us leaving one of three full-scale tests with no data. A great number of hours have been spent not only acquiring and altering this two-channeled sound card, but also developing other aspects of the prototype, such as post-processing scripts designed for a two-channeled sound card.

The idea that one needs a two-channel sound card to perform this task is, however, wrong. When it was determined that the sound card was too unstable for further use and that there was no time to do acquire a new one, we were forced to consider solutions with the one channel sound card. A solution where the time-stamping signal was reduced to make the sonar blind for only four samples was found. This limits the minimum range of the system to 13 cm and gives a blind-spot of 90 μ s every second, which does not reduce the performance of the solution in practice.

This, arguably, premature commitment to a small part of the solution space can be viewed as design fixation as addressed in Purcell & Gero (1996). Design fixation is likely to prevent the designer from reaching their full creative potential Youmans (2011), and many of the strengths of the Wayfaring Method are mitigated as you allow insights to guide you only in a limited set of directions. Design fixation is something one needs to be wary of and is something we would like to prevent in potential further work. Specifically, we will advise the use of physical prototypes when possible, and the TrollLabs community as a substitute for designing as a group, as suggested by Youmans (2011).

6.6 SUMMARY OF METHOD

By combining two design approach in stark contrast we have, in our opinion, been able to harvest supplementing strengths from the two, but also fallen victim to their weaknesses. The weaknesses mainly being fixation on prototyping our solution at the cost of capturing knowledge of the problem space, and a premature commitment to a unwise design choice. The strength being the ability to design an intricate prototype with a planned input and output, without in detail knowing exactly how the different subsystems should meet their requirements. Exploring the solution space with bias toward building and testing has also proven to be an effective way identify and bridge knowledge gaps for a mechanical engineering student with limited prior knowledge of electronics and acoustics.

6.7 FUTURE WORK

6.7.1 PROTOTYPE TEST ENVIRONMENT

One of the main challenges with this project has been the inaccessibility of the intended test environment. We, therefore, suggest that in future work, one should prioritize to prototype relevant test environments. Winjum et al. (2017) suggests that one should prototype the test environment as well as the solution. This would give one the opportunity to isolate variables more easily. It would also greatly increase the accessibility and, by extension, possibly the amounts of tests performed during the project. A higher amount of tests will increase the amount of knowledge gained, and the ability to isolate variables will make the capturing of knowledge, more efficient.

One would have many possibilities with just a water-filled pipe on the ground or in a pool. In our experience, accessible long pipe stretches have been surprisingly hard to find. Through this project, we have gained knowledge of the distance variable, so starting with test environments with shorter lengths would be a quick and easy way to capture knowledge of pipe diameter, pipe material, and pipe bends. We also highly suggest a test-setup where all test variables can be controlled by reliable measurement methods.

6.7.2 LEARN THE EFFECTS OF PIPE-BENDS AND PIPE-MATERIAL

Of all the error sources in the integration test in the intended environment, we suspect that reflection is the most dominant. We would, therefore, suggest capturing knowledge of how the two variables, pipe bends, and pipe material, affect the pinger pulse. Knowledge of these variables is important for further testing, independently, if this was the contributing error source for our test. If these variables are dominant decreasing elements of the range of the prototype, it may implicate the need for major design changes or limited the application field for the concept. That is why, in our opinion, testing these variables should be prioritized.

6.7.3 MAP EFFECT OF FREQUENCY PARAMETER WITH PIPE-DIAMETER

A pressure wave with a wavelength much greater than the diameter of the pipe it is traversing, propagates homogeneously along the axis of the pipe Heller (2013). This more uniform

propagation of the pressure waves may, in total, have fewer reflections and a shorter real distance traveled, thus leading to a possibly greater range.

This parameter is also important to test in regards to the two variables in the previous subsection. How these uniform pressure waves traverse bends of different angles and how different frequencies perform in different pipe materials are important knowledge for further testing as well as the use of the concept.

6.7.4 DESIGN THE SYSTEM FOR SIGNAL COMPRESSION AND MATCH FILTERING

Signal compression and match filtering are techniques that ultimately increase the practical range of the solution by enhancing the readability of the received signal. Instead of emitting a pulse with a constant frequency as we have in this project, the frequency of the pulse typically increases through the emission of the pulse. When analyzing the received signal, instead of searching sudden increases in a certain frequency, one searches for this particular pattern of which the pulse is emitted. This is in essence what is called match filtering. Enabling this capability, requires no major design changes other than the post-processing software, and maybe optimizing the pinger-transducer. The accuracy of this technique is proportional to the frequency range that is used. This is important to consider when designing or choosing the next pinger-transducer. To learn if these techniques are feasible for our concept, and in case what the optimal frequency range is, testing is required.

6.7.5 OTHER PULSE PARAMETER CONFIGURATIONS

During the integration testing in this project, we emitted pulses with a variety of parameter configurations. Because of the prototypes inability to receive signals in the intended environment and a priority on other variables we have little data on how the different signal configurations compare in terms of clean, accurate, high range measurements. To have the main frequency at 15kHz was chosen because of the pinger-transducer properties, and other parameter configurations of the pulse have been chosen on the basis of advice from professionals. It is, for instance, possible that measurement with the sonar moving inside pipes reveals a requirement for a higher measurement rate.

6.7.6 EXPLORE PIPE MOVEMENT AND FORM FACTOR OF SONAR

During this project, we were not able to test the sonar's ability to move through or it's properties while moving through operational pipes. In regards to this project, this is an uncharted territory that is critical for the concept. Other than testing that the sound of rolling did not saturate the sonar-transducer, no tests of the properties of the moving sonar have been performed. This may introduce a variety of noise and physical abuse, which requires consideration in the further development. Note that the physical limitation of the entry or exit point may be different than the actual pipe diameter. These key points should, therefore, also be mapped.

How the distance measurement performs with a moving sonar should also be tested. The water flow in a pipe may vary greatly and rapidly, and this is hard to control. The system should, therefore, be robust to these conditions, and deliver accurate measurements independently. A change in measurement rate may be relevant to fit this variable.

There are also easy alterations that may reduce the amount of movement generated sound, such as lathing the sonar as a sphere and covering it in a softer material. This potential problem and these possible solutions should be tested.

6.7.7 PROTOTYPE A MORE OPTIMAL PINGER-TRANSDUCER

A more optimal pinger-transducer may be chosen or built for future prototypes to increase the range. A new iteration of the pinger-transducer should, based on our findings, have a high electronic efficiency at frequencies that are found to be optimal, be as wide-banded as possible signal compression requires, and have a radiation shape that is more fitting for sending a pressure wave through a pipe. The half-spherical radiation shape of the current prototype is practical in terms of mounting and aiming, but we suspect that there is an amount of wasted mechanical energy. This energy could be used in the directed pressure wave instead.

6.7.8 TEST POWER SOURCES AND AMPLIFICATION

Based on the intensity of the signals one is to emit, there are different options, we suspect. For testing in the field, we found it highly practical to use a car battery with the car engine running as our power source. It is unknown how much power the pinger system requires when operational, and it is also unknown how much power the car has delivered. This should be tested. If the current solution is determined to be insufficient, we suspect that the problem is not that the system requires too much energy, but that it requires too much energy over to little time. This may theoretically be solved by implementing a capacitor, which can be considered and tested. There are, of course, also other options like generators.

6.7.9 QUANTIFY LEAKAGES BASED ON SOUND SIGNATURE

Professionals at Trondheim Vann og Avløp think that there may be a relationship between the flow of a leak and the loudness of the generated noise. Creating a calibration test where important variables like pressure and distance are considered, one can maybe find such a relationship. This might give our concept the new capability of determining the size of leakages. Because the size of the leakage is one of the dominant variables when Trondheim Vann og Avløp prioritizes what to repair, this added capability may be of great value. A deeper understanding of how the sonar perceives leakages may also open up the possibility of creating software to post-process the data more efficiently.

6.7.10 ARTIFICIAL INTELLIGENCE FOR POST-PROCESSING

We have observed that leakages create stable low-frequency noise that is loud compared to its environments, but our experience suggests that it might be difficult to quantify leakages and other noises accurately in such a way that a regular software accurately can distinguish between different phenomena.

We have also experienced that professionals have the ability to separate different phenomena with the human ear. This leads us to think that it may be possible to create an artificial intelligence to quickly process all gathered data which will output just the relevant

information to the inspector. We have not looked deeper into this theory, but we suspect that it is a possibility.

6.7.11 MAP ACOUSTIC EFFECTS OF GAS POCKETS, ARMATURES AND OTHER PIPE BODIES

It may be important to understand the acoustic effects for armatures and other pipe bodies, to be able to perform valuable long-range inspections. This may be especially important when dimension pinger-pulse parameters. Capturing knowledge of the sound signature of gas pockets and other phenomena in pipes, might also add new capabilities to the concept.

7 CONCLUSION

This master thesis has aimed to develop a new low-cost concept to locate water pipe leakages. Through prototyping with rapid iterations, insights have been gained, and knowledge regarding the problem and our solution have been captured. The two key variables in this concept that together identify a leakage's location are the distance from the start point to the sonar and the SPL ambient to the sonar. In the pre-project, a clear vision of ways to measure these variables was attained. In this project, the feasibility of these methods have been tested, and the influence of different parameters have been explored. Through utilizing the exploratory approach of the Wayfaring Method within the framework of engineering design, the solution space has been efficiently mapped out. Three subsystems of the prototype have been developed concurrently to fit both requirements set from the start and emerging requirements. The final prototype has been tested to measure the two key variables successfully. Although the distance measurement is accurate and has a sufficient extrapolated range in an underwater environment, the results are not equal when tested in a pipe-system. This illustrates not only insufficient knowledge of the problem space but also of how the integrated solution interacts with the problem space. We suspect that prototyping test environments to fit specific test variables and testing in them would have given valuable knowledge of the problem space Winjum et al. (2017). However, we argue that in order to unveil what relevant attributes that are different between a test environment and the intended environment to our solution, one must test the solution in the actual environment as well. Testing in the intended environment may reveal wrong assumptions and limited knowledge that prototyped test setups never can. This because both the prototyped solution and the prototyped test environment are made with the same foundation of knowledge and assumptions. Therefore, it is suggested that the product developer should early-on actively alternate testing the prototype integrated into the actual environment and a prototyped test environments in future work. Based on the results, the concept is considered feasible, with important unanswered questions. Future work should, therefore, start by developing a test setup with the ability to isolate and measure relevant variables accurately. This may increase the speed and relevance of future data capturing. Furthermore, it is suggested a set of specific alterations on the prototype that may increase range, as well as other improvements that may add capabilities and increase the concept's application field.

REFERENCES

-
- Ainslie, M. A. & McColm, J. G. (1998), 'A simplified formula for viscous and chemical absorption in sea water', *The Journal of the Acoustical Society of America* **103**(3), 1671–1672.
- Berglund, A. & Leifer, L. (2013), 'Why we prototype! an international comparison of the linkage between embedded knowledge and objective learning', *Engineering Education* **8**(1), 2–15.
- Fantozzi, M., Di Chirico, G., Fontana, E., Association, A. W. W. et al. (1993), Leak inspection on water pipelines by acoustic emission with cross-correlation method, in 'AWWA 1993 Annual Conference', AWWA, pp. 609–21.
- Fuchs, H. & Riehle, R. (1991), 'Ten years of experience with leak detection by acoustic signal analysis', *Applied acoustics* **33**(1), 1–19.
- Gerstenberg, A., Sjöman, H., Reime, T., Abrahamsson, P. & Steinert, M. (2015), Vol. 9353, Springer Verlag, pp. 409–416.
- Heller, E. J. (2013), *Why you hear what you hear: an experiential approach to sound, music, and psychoacoustics*, Princeton University Press.
- Kennedy, B. M., Sobek, D. K. & Kennedy, M. N. (2014), 'Reducing rework by applying set-based practices early in the systems engineering process', *Systems Engineering* **17**(3), 278–296.
- Kriesi, C., Blindheim, J., Bjelland, Ø. & Steinert, M. (2016), 'Creating dynamic requirements through iteratively prototyping critical functionalities', *Procedia CIRP* **50**(C), 790–795.
- Liston, D. A. & Liston, J. D. (1992), 'Leak detection techniques', *Journal of the New England Water Works Association JNEWA* **6**, **106**(2).
- Norsk Vann, B. (2017), 'Tilstandsvurdering av kommunale vann- og avløpstjenester, bedrevann'. Accessed February 2020.
URL: <https://bedrevann.no/pdf/bedreVANN2017.pdf>
- Pahl, G. & Beitz, W. (2013), *Engineering design: a systematic approach*, Springer Science & Business Media.
- Purcell, A. T. & Gero, J. S. (1996), 'Design and other types of fixation', *Design studies* **17**(4), 363–383.
- Regtien, P. P. & Dertien, E. (2018), *Sensors for mechatronics*, Elsevier.
- Schón, D. (1983), 'Ttu, reflective practitioner'.
- Schrage, M. (1996), 'Cultures of prototyping'.

- Selfridge, A. R. (1985), ‘Approximate material properties in isotropic materials’, *IEEE transactions on sonics and ultrasonics* **32**(3), 381–394.
- Sherman, C. H. & Butler, J. L. (2007), *Transducers and arrays for underwater sound*, Vol. 4, Springer.
- Smartball by Pure Technologies* (2020). Accessed February 2020.
URL: <https://puretechltd.com/technology/smartball-leak-detection/>
- Sobek, Durward K., I., Ward, A. C. & Liker, J. K. (1999), ‘Toyota’s principles of set-based concurrent engineering’, *Sloan Management Review* **40**(2).
- Steinert, M. & Leifer, L. (2012), ‘‘finding one’s way’’: Re-discovering a hunter-gatherer model based on wayfaring’, *International Journal of Engineering Education* **28**, 251–252.
- Sutcliffe, A. & Sawyer, P. (2013), Requirements elicitation: Towards the unknown unknowns, *in* ‘2013 21st IEEE International Requirements Engineering Conference (RE)’, IEEE, pp. 92–104.
- Winjum, J., Wulvik, A., Erichsen, J. A., Welo, T. & Steinert, M. (2017), A heuristic approach for early-stage product development in extreme environments, *in* ‘2017 International Conference on Engineering, Technology and Innovation (ICE/ITMC)’, IEEE, pp. 619–625.
- Youmans, R. J. (2011), ‘The effects of physical prototyping and group work on the reduction of design fixation’, *Design Studies* **32**(2), 115–138.

A THE RECORDING SCRIPT OF THE SONAR

```
import pyaudio
import wave
from datetime import datetime
import os.path

while True:

    form_1 = pyaudio.paInt24 # 24-bit resolution
    chans = 2 #number of channels (1 or 2)
    samp_rate = 44100 # 44.1kHz sampling rate
    chunk = 4096 # 2^12 samples for buffer
    record_secs = 10 # seconds to record
    dev_index = 2 # device index found by p.get_device_info_by_index(ii)

    save_path = '/home/pi/Desktop/Recordings' # Location to store recordings.

    now = str(datetime.now())[5:19] #Get date + time for filename
    nower = now[0:8] + "." + now[9:11] + "." + now[12:14] # Changes ':' to '.'
    wav_output_filename = "Rec_" + nower + ".wav" # name of .wav file

    audio = pyaudio.PyAudio() # create pyaudio instantiation

    # create pyaudio stream
    stream = audio.open(format = form_1, rate = samp_rate, channels = chans, \
        input_device_index = dev_index, input = True, \
        frames_per_buffer=chunk)
    # print("recording")
    frames = []

    # loop through stream and append audio chunks to frame array
    for ii in range(0, int((samp_rate/chunk)*record_secs)):
        data = stream.read(chunk)
        frames.append(data)

    #print("finished recording")

    # stop the stream, close it, and terminate the pyaudio instantiation
    stream.stop_stream()
    stream.close()
    audio.terminate()
```

```
# save the audio frames as .wav file
completeName = os.path.join(save_path, wav_output_filename)
wavefile = wave.open(completeName, 'wb')
wavefile.setnchannels(chans)
wavefile.setsampwidth(audio.get_sample_size(form_1))
wavefile.setframerate(samp_rate)
wavefile.writeframes(b''.join(frames))
wavefile.close()
```

B POST-PROCESSING SCRIPT OF RECORDED DATA IN MATLAB

```

filename = 'Avstandsmaling16031V.wav' %User enters name of file
fs = 44100; %sampling freq
SpeedOfSound= 1465; %m/s
sample = audioread(filename);
C1 = sample(:,1); % Extract one channel

%Creating a vector to hold the samplenumbers of all the timestamps from
%local GPS
C1_InternalPings = [];
n = 1;
while n <= length(C1)
    if (C1(n) >= 0.9)
        C1_InternalPings = [C1_InternalPings n];
        n= n+42000;
    else
        n=n+1;
    end
end
% Finds the highest amplitude of the pinger-pulse
HighestReceived =0;
n=1;
while n <= length(C1)
    if (C1(n) <= 0.9 && C1(n) > HighestReceived)
        HighestReceived = C1(n);
    end
    n=n+1;
end
%Counts the number of samples from time-stamp to onset og pinger-pulse , and
%calculates the average.
C1_DeltaSamples = [];
for i = 1 : length(C1_InternalPings)
    j=0;
    n=0;
    while j < 0.00005
        j = C1(C1_InternalPings(i)+20+n);
        n=n+1;
    end
    C1_DeltaSamples = [C1_DeltaSamples (20+n)];
end
AverageDeltaSample = mean(C1_DeltaSamples);

```

```
%Plots channel one of the signal so that the user may quickly determine the  
%validity of the recieved data.
```

```
plot (C1);
```

```
%Calculates the time difference and distance
```

```
Time = AverageDeltaSample /fs;
```

```
DistanceMeasured = Time * SpeedOfSound
```



Norwegian University of
Science and Technology

PROJECT THESIS

Development of a low cost underwater distance
measurement sensor

Johan Christian Wigen Hjorth

June 2019

Norwegian University of Science and Technology (NTNU)

Department of Mechanical and Industrial Engineering (MTP)

Supervisor: Martin Steinert



Abstract

50 % of Europe's energy storage potential is in Norwegian Hydro power systems. There are 3500km of rock blasted water tunnels made over the last century with a dropping efficiency, many yet to be inspected. Presently, the tunnels are inspected by foot which is a high-cost solution that is damaging to the tunnels as well as dangerous to inspectors. This project thesis aims to uncover variables that represent the status of a water conveyor as well as exploring methods of capturing them. Through the use of the Wayfaring Method, this project explores different low-cost options of capturing these variables. In the early phases of product development, the aim is to map out the solution space efficiently to prevent the need for later rework. Exploratory prototyping with rapid design iterations has been used to probe ideas with design-build-test cycles. In this way, knowledge gaps have been bridged and dynamic requirements for a solution have been defined. It was found that comparing continuous height measurements of the tunnel with the known dimensions would be a good variable of the shape, form, amount and location of accumulated sediment, which in turn can give the operators knowledge of how to run the process in a way that drags less sediment into the tunnel. There was no suitable off-the-shelf measuring method found through testing, which was adaptable to our use case. To solve this, a highly adaptable modular sonar was developed with promising results. In future work, a format of captured data will be chosen and the sensor will be adapted to a specific water conveyor inspection case. Options are pipe leak detection, speed and location determination or a sediment measurement which is not dependent on previous knowledge of the conveyor. The outcome of this project is a deeper knowledge of the problem and a highly adaptable prototype that will make prototyping in future work easier.

ACKNOWLEDGEMENTS

I would like to thank Martin Steinert for including me in the TrollLabs community, which have helped me nurture my ideas and provided me with technical knowledge and generative questions. I would also like to thank Trønder Energi for giving me a firsthand experience of how a maintenance engineer work, and Norbit which have provided important technical help.

<i>CONTENTS</i>	vi
-----------------	----

CONTENTS

Abstract	ii
Preface	iv
Contents	vi
List of Figures	viii
1 Introduction & Background	1
1.1 Approach: Wayfaring Method	1
1.2 Motivation	2
1.3 Status of Norwegian water distribution system	3
1.4 Earlier works	3
1.5 Scope	3
1.6 Thesis structure	4
2 Problem Statement	5
2.1 The hydro power tunnel environment	5
2.2 What is the purpose of an inspection?	7
2.3 How are the tunnels inspected today?	8
2.4 Problem Statement	8
2.5 Defining the problem	9
2.6 Research Questions	10
3 Off-the-shelf methods	11
3.1 Simple ultrasonic put under water	11
3.2 RADAR	12
3.3 LIDAR	14
3.4 Turbidity Sensor	15
3.5 Summary	18
4 Modular Sonar	19
4.1 Theory	19
4.2 Prototype	22
4.3 Test	29
4.4 Conclusion	35
5 Emerging requirements	36
5.1 Data requirements	36
5.2 Sensor requirements	36
5.3 Pulse requirements	36

<i>CONTENTS</i>	vii
6 Discussion and Future Work	37
6.1 Results and comparison	37
6.2 Method	37
6.3 Concept	38
6.4 Limitation of research	38
6.5 Future work	39
7 Conclusion	43
Bibliography	44
Appendix A Arduino Code Ultrasonic module.	46
Appendix B Arduino Code for Lidar Tests	47
Appendix C Arduino Code for Turbidity measurements	48
Appendix D Risk Assesment for Metallography Lab	49

LIST OF FIGURES

1.1	The Hunter-Gatherer Model Steinert & Leifer (2012)	2
2.1	Sketch of the start of the tunnel at Simsfossen power plant. Drawing is provided by Trønder Energi.	5
2.2	In the middle of the tunnel there is a surge chamber from which onw can control water flow with a simple hatch.	6
2.3	Sketch of the end of Simsfossen water tunnel leads to the fine grid and final surge chamber.	7
2.4	A picture from the site visit of the surge chamber at the end of the water tunnel at Simsfossen.	8
2.5	A rough sketch of Simsfossen, aspects of an inspection and their potential physical properties	9
2.6	Illustration of the measuring problem	10
3.1	Image of the HC-SR04 from a distributors website 14.06.2019. URL: https://www.iot-store.com.au/products/ultrasonic-ranging-module-hc-sr04	11
3.2	Representation of RADAR response. y-axis is time, x-axis is distance and color is reflection density	12
3.3	Test setup of the the radar sensor submerged in water.	13
3.4	Garmin Lidar lite v3. A lightweight and compact LIDAR sensor.	14
3.5	Two working principles of turbidity measurement	15
3.6	Sensor used for all turbidity testing. Images are from a distributors website 14.06.2019. URL : https://wiki.dfrobot.com/Turbidity_sensor_SKU_sEN0189	16
3.7	Turbidity in 3.6 L of water. 10g of soil is added every 25 datapoint.	17
3.8	Test revealing the relationship between turbidity and movement in liquid container.	18
4.1	Reflection and transmission of an incident wave on a normal boundary	20
4.2	Acoustic material data on common materials from Regtien & Dertien (2018)	21
4.3	Illustration of wave dissipation	22
4.4	The transducer provided by Norbit.	23
4.5	Conductance of transducer.	24
4.6	The oscilloscope: the Analog Discovery 2 board	25
4.7	The oscilloscope interface while emitting and receiving signals.	26
4.8	AIB Circuit Design sketch	27
4.9	Circuit of the Analog Interface Board	28
4.10	Final prototype of the Analog Interface Board	29
4.11	The echo response in tank.	30
4.12	Schematic of the different echos	31
4.13	Maximum echo response at 63 cm	32
4.14	Relationship between sonar maximum range and turbidity measured at two different points relative to the transducer.	33
6.1	Summary of TIF-sensors results	37

1 INTRODUCTION & BACKGROUND

The purpose of this project thesis is to explore different ways to inspect underwater channels, tunnels and pipes. Due to the hazardous conditions these environments represent, the methods explored need to be low-cost, robust and possible to make cord independent. The focus has been on different ways to measure distance and measure sediment levels. In this, we will illuminate the limitations and applications fields of different physical principles and practical methods.

1.1 APPROACH: WAYFARING METHOD

To gain knowledge of the problem at hand an exploratory approach with an emphasis on testing to learn has been used. The approach which is often referred to as the Wayfaring Method was described by Gerstenberg et al. (2015) which again was based on the Hunter-Gatherer Model introduced by Steinert & Leifer (2012). As with the old wayfaring way of traveling, the method can be visualized as a map where the end-point changes as the path is explored along the way. Newly gained knowledge from probed ideas guides the direction of where to go next on the idea hunt. Ideally, a team with a diverse skill set probes the solution space, by building rapid prototypes and testing them in design-build-test cycles. The aim of these prototypes is not to make perfect solutions, but to rapidly learn more about their current surroundings in the solution space. This way of letting insights guide you through the solution space can lead you to unexpected twists and turns which may help you find unknown unknowns and uncover ‘the big next idea’ as referred to by Steinert & Leifer (2012). In addition to this one can through this journey set dynamic requirements as one learns more about the problem and possible solutions. This way of letting the insights from exploring setting the requirements may generate more radical and innovative solutions as proposed by Kriesi et al. (2016).

1 INTRODUCTION & BACKGROUND

3

several kilometers long. To this date, over 3500km of tunnels for water transportation have been blasted or excavated.

A study, Thidemann & Bruland (1991) revealed that a minor rockfall ($V > 5m^3$) per 5.1 kilometres tunnel with an average cross-sectional reduction of 'A = 20 %' occurred. The study was based on reports and inspections of 45 different tunnels, covering a total length of 330 km. According to the similar recent study Bråtveit et al. (2016) from ten different tunnels, with a total length of 107 km, it occurred a minor rockfall every 3.1 kilometers. The reduction of the cross-sectional area was found to be 'A = 10%'. The study also revealed that they have been running since their commission, most in the 1950s and 1960s, as well as the fact that they are seldom inspected. In both studies, the tunnels were inspected whilst drained.

1.3 STATUS OF NORWEGIAN WATER DISTRIBUTION SYSTEM

In 2017 bedreVANN published a rapport Norsk Vann (2017) on the quality of the 81 Norwegian municipalities' water and sewage systems. Water loss is determined as the difference between the amount of water supplied to the distribution network and the measured or estimated consumed. Out of the 81 participating municipalities 9% have a water loss less than 20%, and 40 % of the municipalities have a water loss higher than 40%. The rapport also reveals that amongst the participating municipalities there is an average 0.06 sewage blockages per km in 2017. Only 50% of the studied pipe network has a sufficient standard. This is not sustainable in economic or environmental terms.

1.4 EARLIER WORKS

In the fall of 2017 and spring of 2018 Egil Aasboe, Jørgen Simensen Almankaas and Almir Pidic wrote their project and master thesis Aasboe et al. (2017) "Development of a Low-Cost Autonomous Underwater Vehicle (AUV) for Inspection of Water-Filled tunnels During Operation". Their objective was to locate and evaluate potential collapse(s) in Alcoa's water tunnel by the means of a new low-cost Autonomous Underwater Vehicle. The AUV produces a two-dimensional height vs. time plot of the tunnel contour, by varying its buoyancy while being dragged by the water stream through the tunnel. Due to the low cost and simplicity of the AUV, one can easily send in several or many times to cross-check the result. Comparing this plot with original tunnel schematics afterward would indicate height, position and obstacles. The results were accepted for publication by the American Society of Mechanical Engineers (ASME), and the AUV's proof of concept was verified in two of Trønder Energis discharge tunnels with the length of 600 m and 1100 m. No AUVs were able to traverse the case tunnel at Alcoa due to a suspected too large collapse preventing the vehicle to pass.

1.5 SCOPE

This project thesis is based on early idea generation, where many concepts and physical principles will be tested. The focus of the project has been determining the dimensions and material composition of the surrounding environment in a water conveyor, in a way that

1 INTRODUCTION & BACKGROUND

4

could fit a low-cost AUV concept. Determining the location, implementing the sensors in an AUV and user interaction is beyond the scope of the project.

1.6 THESIS STRUCTURE

First, the investigation of the initial problem will be presented, ending with a specific set of research questions as the thesis' aim. Different solution methods will be explored with design-build-test cycles. The relevant theory will be presented as a foundation for the reader to understand the testing and decisions done. The first methods are off-the-shelf sensors used in new ways, while the modular sonar is made from the ground up. This strategy shift in the prototyping will be presented with a full section as it is more comprehensive. The emerging requirements will then be presented followed by results, discussion and conclusion. The main focus from start has been hydropower tunnels, but as many solutions and problems are adaptable to water pipes, some background information of Norwegian drinking water distribution system is added. The term 'water conveyor' will be used to describe a general structure that conveys water as a water tunnel or pipe.

2 PROBLEM STATEMENT

In this section the reader will be presented with a description of the problem space. A thorough description of the water tunnel environment as well as a description of current inspection purposes and practices, will be presented. The section is summed up by a problem statement, a problem definition as well as specific research questions, which will be the aim of the project thesis.

2.1 THE HYDRO POWER TUNNEL ENVIRONMENT

In the early 19 hundreds the Norwegian Government started developing water power plants. Today, there are 976 water power plant stations operating in Norway Linjar (2018). Because of the geographical differences of every plant, and different available technology at time of build, the power plant layout and available information about them vary a lot, even though the theoretical principle remains the same.

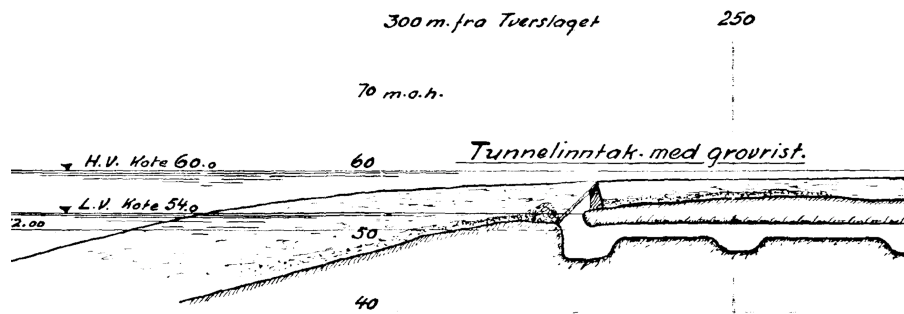

Figure 2.1: Sketch of the start of the tunnel at Simsfossen power plant. Drawing is provided by Trønder Energi.

To illustrate the hazardous conditions of a typical water conveyor we will give a brief description of Simsfossen hydro tunnel. A hand drawn length profile of Simsfossen power plant provided by Trønder Energi, from 1920, can be seen in figure 2.1, 2.2, and 2.3, respectively. This operational power plant is simple and small, both in terms of power and elevation change, however, the working principle of the power plant tunnel is the same. It will therefore serve as a model for understanding a typical rock-blasted tunnel in Norwegian Hydro plant systems.

The opening of the tunnel is located 4-6 m beneath the surface in a water depository, typically a lake. To prevent debris from flowing into the tunnel, a coarse grid at the entrance of the tunnel is used. At Simsfossen, the grid is made up of wooden beams with approximately 20 cm spacing. The tunnel has a cross section of $2 * 2m$, with a water speed of $0.5m/s$, and a drop of 1:400. The length is right above 500 m, however, more modern tunnels are typically

2 PROBLEM STATEMENT

6

several kilometers long. There are four indents, some of them are made for construction purposes, but all work today as sand traps. In the middle of the tunnel there is surge camber with a hatch. There is no way to drain the tunnel above this point. At the end of the tunnel there is another surge camber and a finer grid which leads down to the turbine. The spacing at this grid is 27mm . On this mesh there is a horizontal bar which is moved up and down along the grid surface to remove accumulated sediment and small debris. This can be done while the tunnel is operational, and is done once a month at Simsfossen. The tunnel wall thickness and water make wireless communication nearly impossible, and the typical length make inspections with umbilical dependent ROW nearly impossible.

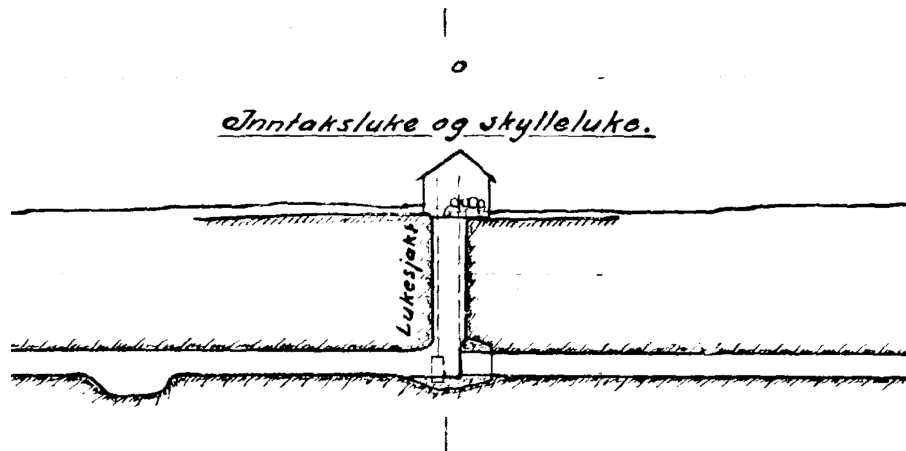

Figure 2.2: In the middle of the tunnel there is a surge chamber from which onw can control water flow with a simple hatch.

Note that dimensions given in this description are not accurate, because they are either an estimation done by employees at Trønder Energy or based on a century old hand drawn schematic. As the aim is to present the working principles of the tunnel environment, accuracy is not viewed as important in this aspect. The crude knowledge we have on layout and status of Simsfossen serves as a good example of information available of operational Norwegian water conveyors.

2 PROBLEM STATEMENT

7

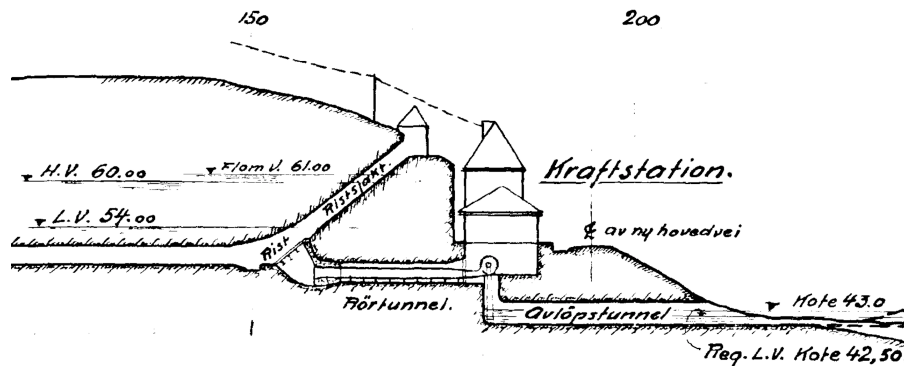

Figure 2.3: Sketch of the end of Simsfossen water tunnel leads to the fine grid and final surge chamber.

2.2 WHAT IS THE PURPOSE OF AN INSPECTION?

The purpose of an inspection is to gain knowledge of the status of the water conveyor so that smaller measures can be taken early, to prevent higher costs in the future. In this there are several objectives and questions of which the inspectors seek to find the answer.

- Learn how different ways of operation effect the state of the tunnel. It has for instance been suggested that abrupt fluctuation in the water stream carry more sediments into the system.
- Gain knowledge of the reason why the effectiveness of a tunnel may be dropping.
- Locate collapses or obstructions.
- Map out risk for potential collapses or obstructions.
- Determining the need for maintenance in more general terms.
- Plan removal of accumulated sediment and collapsed rocks.

2 PROBLEM STATEMENT

8

2.3 HOW ARE THE TUNNELS INSPECTED TODAY?



Figure 2.4: A picture from the site visit of the surge chamber at the end of the water tunnel at Simsfossen.

The height of the reservoir water, water flow, and generated power are measured at all times. Comparing these variables gives an estimate on the amount of energy loss in the tunnel. The variable of height-loss is the only real time information available of the typical tunnels status. Inspections are today done by draining the tunnels, then securing the tunnels from collapses. Workers at that point walk through, and the tunnels are inspected visually. Depending on the power plant, each of these steps may take several days. This represents a significant economic loss, and a safety hazard to the inspectors. The process sustains damage to the tunnel as the removal of buoyancy compromises its structural integrity and triggers collapses.

2.4 PROBLEM STATEMENT

Today there is no low-cost and safe way to inspect underwater pipes or tunnels, which again will prevent higher costs and hazards. Several methods of doing this will be explored and tested as a basis for further work in a master's thesis.

2 PROBLEM STATEMENT

9

2.5 DEFINING THE PROBLEM



Figure 2.5: A rough sketch of Simsfossen, aspects of an inspection and their potential physical properties

The initial perspective of the problem was that the aim of the inspectors was to locate collapses in the tunnels. Different physical aspects of the tunnels and the problem of the tunnels were mapped out as in figure 2.5. To gain a better understanding of how hydro plants are operated, and on challenges faced, several interviews were conducted with maintenance engineers at Trønder Energi and professors at NTNU.

One critical insight gained from the interviews, was the fact that they don't view collapses as the significant issue to the effectiveness of the tunnels. Smaller collapses occur and it is a serious issue when the tunnels are drained and inspectors go in by foot. The typical challenge of an old tunnel is not blockades of piles of rocks, but the slow accumulation of sediment reducing the effective height of the tunnel. This also causes blocking of grinds and damaging particles in the turbines.

Based on these finds we went back to our map of the physical aspects of the tunnels. It can be concluded that accurate measuring of the tunnel height would be a logical aspect to start with. By comparing effective height with measured or the known total height from

2 PROBLEM STATEMENT

10

schematics, one can estimate the amount of accumulated sediment. Later on, the scope of the project grew to see if we could find a way to measure the amount of sediment in moving water as well as measuring the amount of accumulated sediment, in a low cost and robust manner.

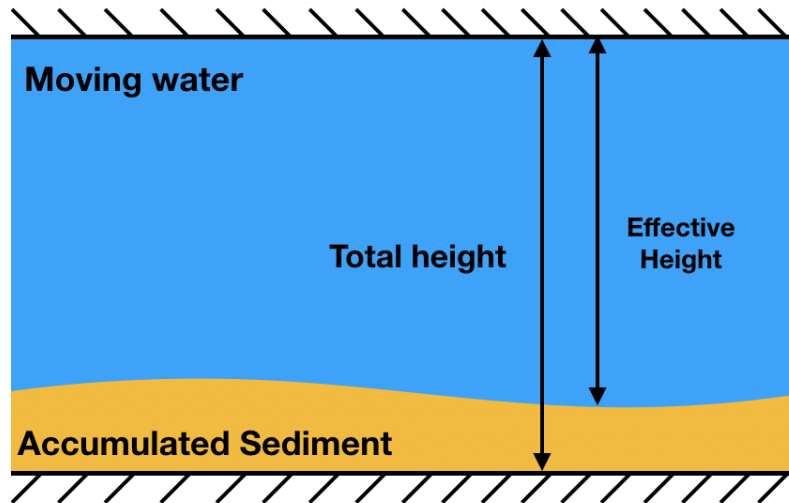

Figure 2.6: Illustration of the measuring problem

2.6 RESEARCH QUESTIONS

- How might we determine the dimensions of our surrounding environment inside a water conveyor?
- How might we measure the amount of sediment in our environment?

3 OFF-THE-SHELF METHODS

In this section, different measurement methods and activities in the duration of the project will be presented. The common denominator for the methods tested in this section is that they are all low-cost off-the-shelf sensors which are tested for new purposes, because we could not find any suitable off-the-shelf sensors for our use. Aside from what is presented, different sensors were researched, but as they were found to have critical limitations, they were not tested. An example of this is low-cost echo sounders where one can not access the collected data. The basic theory behind the different measurement principles, as well as key insights, will be presented in such a way that the reader will have a foundation to understand the reasoning and decisions made in the process.

3.1 SIMPLE ULTRASONIC PUT UNDER WATER

To quickly get familiar with distance measurements and prototyping in water, we build a simple distance measurement prototype with an ultrasonic HC-SR04 sensor.

3.1.1 THEORY

The sensor emits a 40kHz sound wave and registers the time the signal uses to reflect back on the sensor. By multiplying the transit time τ with an assumed speed of sound in air in regular conditions (343 m/s), a distance approximation is calculated. The sensor has a range of 20mm-4000mm and a resolution of 10 mm.

$$x = \frac{v\tau}{2} \quad (1)$$



Figure 3.1: Image of the HC-SR04 from a distributors website 14.06.2019. URL: <https://www.iot-store.com.au/products/ultrasonic-ranging-module-hc-sr04>

3.1.2 RESULT

This was a quick, low cost and accurate way to measure the distance to plane surfaces. The module is only made for simple measurements in air, and that became apparent when trying to use the module in new ways. We could not read any signals through a water surface or a polymer protective casing. As the module is not waterproof, this rendered it as not useful for our purpose. From this rapid prototype, we gained two insights.

3 OFF-THE-SHELF METHODS

12

- A module such as this is calibrated and optimized for a specific use case. In this, it only outputs the transit time of a certain signal and keeps the rest of the captured data hidden, for the sake of simplicity for the user.
- With a module such as this, you have little to no possibility to alter parameters such as intensity and sensitivity for the same reasons.

3.2 RADAR

Based on attained insights a new sensor was chosen, which comes with a software that gives the user information of the reflection density across its whole range. By the term “reflection density”, we mean the amount of signal which is reflected at all the certain distances within its range. The way it is presented can be seen in figure 3.2. The brighter the color, the more of the signal is reflected from this distance. For our testing, the Xethru X4M300 presence and respiration sensor was used. It is a RADAR sensor which has similarities to the earlier tested sensor, but it propagates electromagnetic and not mechanical waves.

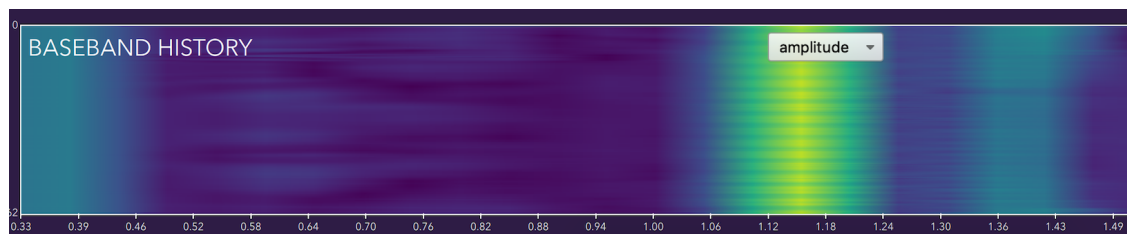

Figure 3.2: Representation of RADAR response. y-axis is time, x-axis is distance and color is reflection density

3.2.1 THEORY

RADAR is originally an acronym for “Radio detection and ranging”. The system operates by transmitting a particular electromagnetic waveform and detect the nature of the received echo signal. This way relative location (and speed) of foreign objects can be determined. The working principle is time-of-flight (TIF) as in subsection 3.1 but the electromagnetic pulses propagate at the speed of light $c = 3 \cdot 10^8 m/s$. Frequencies used in conventional radars extend from 220 MHz to 35GHz, but this does not represent a limit. Frequencies up to 94GHz and down to 2 MHz are used for very specific applications. Higher frequencies are associated with a higher resolution of data but a lower range. As with all distance measurements using the TIF principle, the same limitation on the refresh rate determined by the pulse speed and transit time will be there. An advantage with electromagnetic pulses is that they have the speed of light and we can, in fact, have a fairly high refresh rate on high ranges.

3.2.2 TEST

The test intended to determine if we could measure range underwater and also see what other information we could attain from the reflection density plot. Could we say something of the density of the objects, and what would cause a full reflection or signal shadow? Rapid

3 OFF-THE-SHELF METHODS

13

testing while setting up the sensor revealed that we could, in fact, read distances to different objects, we could send signals through a polymer casing and we could learn something about the reflection density within the range. We also learned that we could not access the raw data, and even the filtered data seemed very noisy. The promising results gave us the incentive to do a test with a higher resolution and submerge the sensor in water.



Figure 3.3: Test setup of the the radar sensor submerged in water.

When entering the water, the data read a full reflection density at the minimum range (330 mm). To circumvent this problem, we tried to change the frequency as well as different types of material of the targeted object. We could only operate the sensor at two frequencies and changing it did not make any difference. When concluding that there was nothing wrong with the test setup we consulted the theory. From this, we learned that microwaves does in fact not penetrate water Mullen et al. (1995). It has been tried with different frequencies, but the high absorption of water makes it very impractical.

3.2.3 RESULT

Some of the same issues with limited opportunity to alter parameters of the sensor were identified with this test. With the sensor, more captured data was available to us. However, this was of little use because of the high reflective barrier of air-water, preventing us from capturing full range data. The sensor, as well as RADAR, was discarded from further exploration in this project. The key insights gained are listed below.

- RADAR is an impractical way of measuring distances underwater because of the high absorption of these frequencies.
- A reflection density plot is an intuitive and easy way to gain information of what you are measuring.
- Testing the sensor directly from air into the water could have given us the insight of its reflective barrier quicker, preventing the need to build a waterproof test setup.

3 OFF-THE-SHELF METHODS

14

3.3 LIDAR

LIDARs are well known for their range and accuracy, and are used for both normal and underwater measurements. Therefore we decided to test how a low-cost LIDAR perform underwater.

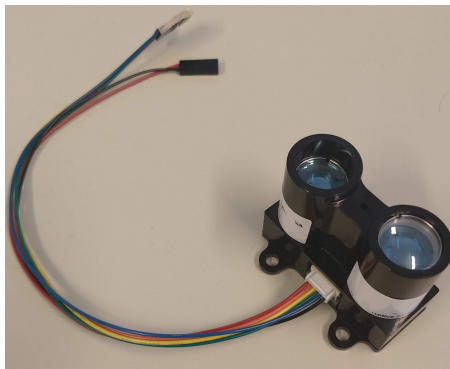

Figure 3.4: Garmin Lidar lite v3. A lightweight and compact LIDAR sensor.

3.3.1 THEORY

LIDAR is a portmanteau for "Light" and RADAR. Radio and RADAR signals have as mentioned frequencies up to the scale of 10^9 , while laser is closer to visible light. In measuring distances with a light beam there are two main principles. Different forms of LASERs or Light Amplification by Stimulated Emission of Radiation, are common to use. The first principle is measuring the phase angle. An amplitude-modulated light beam is directed continuously at a target. The phase angle of the reflected light is measured and the distance to the target is determined. The x is the distance [m], ϕ [r] is the phase angle and λ is the wavelength [m]. If the distance is greater than half the wavelength, the phase does a full rotation and we cannot determine the distance. This is often solved by using multiple wavelengths. This way it can be crosschecked how many rotations the phase does, and the distance can be determined. This measurement is continuous.

$$x = \frac{\phi\lambda}{4\pi} \quad (2)$$

The second main principle is measuring TIF, as in subsection 3.1. Historically this is a costly measuring principle typically used to measure great distances with high precision.

3.3.2 TEST

For testing, the sensor Garmin LIDAR - lite v3 was used. It is a lightweight, compact time of flight sensor. With a range of 50mm to 40 000mm and a resolution of 10 mm. Its update rate is at 500Hz and the wavelength used is 905 nm.

We connected it to an Arduino board and did quick initial testing. From this, we learned that it was an accurate and fast way to measure distances, and that it could measure through water surfaces as well as different polymer protective casings. If we increased the density

3 OFF-THE-SHELF METHODS

15

of sediment in the test water, the measured distance became shorter but to our surprise deviation in the measurements did not increase. This would actually give us false positive measurements. These quick tests was done above the water surface, measuring the content of different water containers. Because of the promising results, we decided to build a water proof test setup and submerge the sensor in water.

3.3.3 RESULT

When having the sensor in a protective casing submerged in water, the sensor could not penetrate the plane boundaries. As we learned that the signal could, in fact, penetrate both the boundaries separately, we know it is a matter of intensity. The sensor was discarded due to the inability to increase its intensity.

3.4 TURBIDITY SENSOR

Tests had shown us that submerging off-the-shelf distance measurement sensors underwater had been problematic. Approaching the problem from a new angle was decided, with a 'dark horse' prototype Steinert & Leifer (2012). If we could we measure the amount of suspended particles in the water flow at different points, maybe we could determine the amount of particles left in the tunnel.

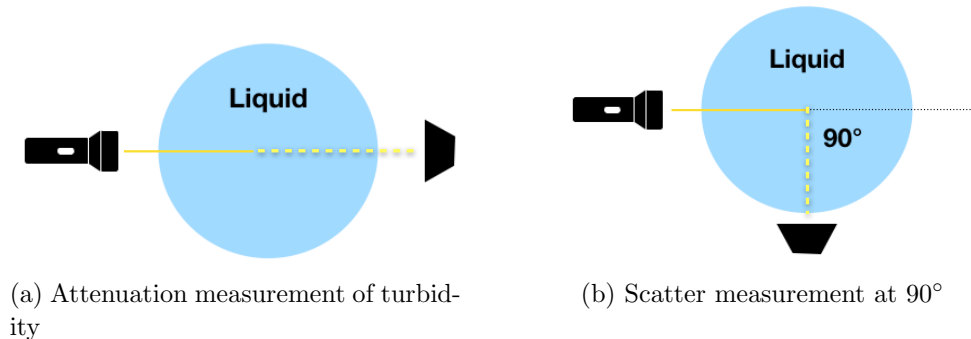

Figure 3.5: Two working principles of turbidity measurement

3.4.1 THEORY

Turbidity is the cloudiness of a liquid, caused by suspended particles. These particles scatter the incident light and this causes the liquid to lose its transparency. As the shape, size, color and reflective properties are dependent on the specific suspended particles, there is no sufficient way to measure turbidity in general. The methods and instruments used are therefore calibrated to very specific use cases. As different methods of measuring are optimal for different cases, there are several standards of both measuring methods and units.

Measuring turbidity objectively is done with two main principles; scatter measurement and attenuation measurement. In attenuation measurement, a light beam is radiated through the medium, and the amount of light able to traverse the medium is measured. With scattering measurement, the light intensity of the reflected light from the suspended particles

3 OFF-THE-SHELF METHODS

16

at a given angle is measured. It can be done at different angles, but 90 degrees is the ISO standard. Measuring liquids with higher turbidity, higher degrees are suitable as there will be more scatter. Some sensors ensure versatility by having measurements at different angles.

The ISO 7027 standard is to use infrared light with a wavelength of 860nm. And the defined International unit for measuring turbidity is FNU or Formazine nephelometric unit. Solutions of 10 g/L hydrazine sulfate and 100 g/L hexamethylenetetramine with ultrapure water left for 24 hours at 25 °C will give a value of 4000 FNU/NTU and 'ultra-clean' water will give 0 FNU/NTU. The Formazine mixture is used because it has been proven to have a high reproducible, due to the solutions homogeneous properties.

3.4.2 TEST

For testing, we used a low-cost turbidity sensor, SKU SEN0189. It was hard to find accurate and credible information about the sensor, but we believe that the sensor uses scatter measurement of a light beam with a wavelength of 500nm, which is the US-EPA 180.1 standard. According to the manufacturer, the relationship between its output voltage and turbidity measured in NTU follows the function given in figure 3.6b.

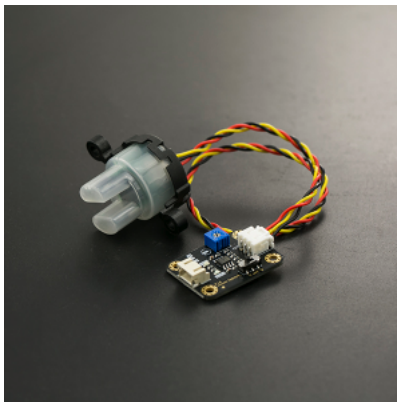

(a) SKU SEN0189

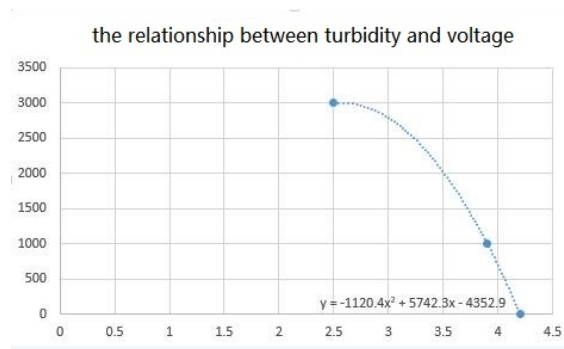

(b) Relationship between voltage and supposed NTU according to manufacturer.

Figure 3.6: Sensor used for all turbidity testing. Images are from a distributors website 14.06.2019. URL : https://wiki.dfrobot.com/Turbidity_sensor_SKU_SEN0189

Our first measurement of regular clean water gave us a result of about 1300 NTU, which is far off an expected 0.5 NTU. The sensor had a potentiometer which should be used for calibration, but this had little to no effect. The sensor did clearly not give us reliable results measured in NTUs. For our use, we did not need specific values measured in NTU or FNU. Therefore we decided to make our own reference scale with sediment. For sediment, we used regular planting soil, because this was accessible and to some extent resemblance to sediments found in underwater channels, tunnels and pipes.

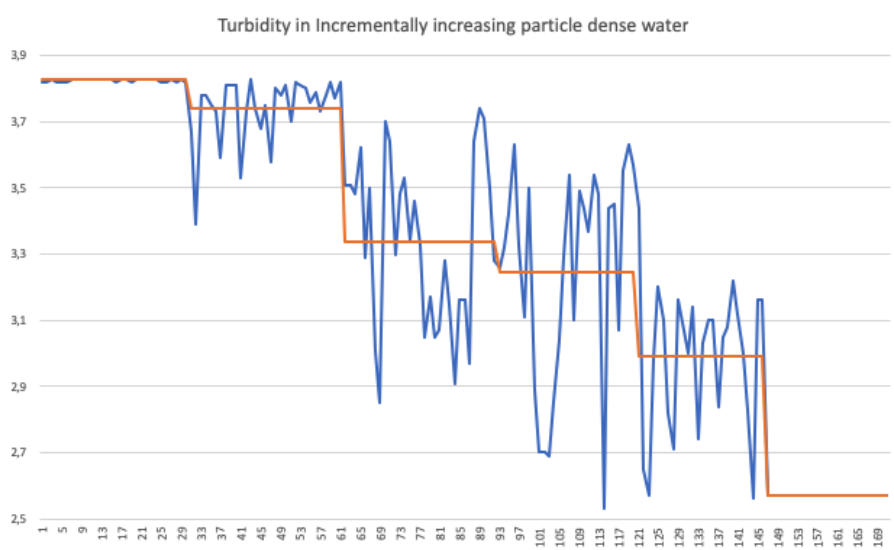

Figure 3.7: Turbidity in 3.6 L of water. 10g of soil is added every 25 datapoint.

With the aim of setting a reference scale for the turbidity sensor, a test was performed in water with different known amounts of soil. A sample of the turbidity of the water was taken every other second, and each soil water solution was sampled 30 times. The density increments are 0 g/L, 2.8 g/L, 5.6 g/L, 8.3 g/L, 11.1g/L and 13.9g/L. The samples are taken in moving water to have a more homogeneous solution as well as resemble moving water. The effect of stirring and turbulence is explored in a later test. When the response is lower than 2.5 V, the manufacturer deems the response as no longer valid. The last increment is therefore outside the measuring range of the sensor. From this test, we learned that clean water is measured with a value of about 3.8 V which leaves a range of 1.3 V with a 0.01 V resolution. We can see that the decrease in voltage is not independent of the increase of soil in the solution. With that said there is a high scattering of responses. To explore how the sensor performed in turbulence opposed to still water we performed another test. Here are stirring and time the only variables and the particle density is constant. This test was done in a container with 24L of water and a particle amount of 3.2 g/L. Every data point represents a time step of two seconds, as the sampling rate is 0.5 Hz. The water is stirred from data point 1 to 25 followed by a 21-minute wait and then stirred again from data point 650 to 675 followed by an eight-minute wait.

3 OFF-THE-SHELF METHODS

18

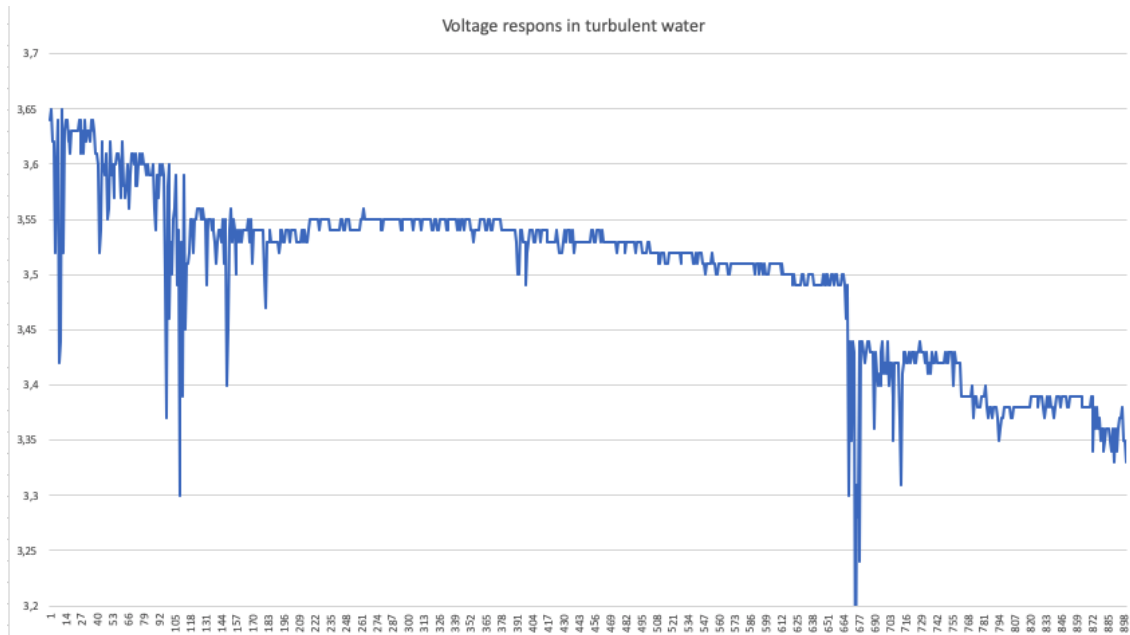

Figure 3.8: Test revealing the relationship between turbidity and movement in liquid container.

We can clearly see that the high movement in the water gives a response with a high variance. After the scattering declines the responses are more stable with a slight increase in measured turbidity. The most interesting find from this test is the fact that the same soil-water solution has a spread in response 0.33V which is 25 percent of the sensors range.

3.4.3 CONCLUSION

Our measurement does not contradict the particle densities of our solutions, but the range of the sensor is very small compared to the variance of the response. Soil does not properly solute in water, but remain as particles that vary much in size, shape and material. This makes noisy turbidity measurements, but may be realistic to our use case. Our findings suggest that a low-cost turbidity measurement does give an indication of the amount of soil in the water, but with a small range and high variance of the response. Assuming that it is possible to measure the difference in amount of suspended particles in the water flow, it will be critical to have a certain degree of accuracy as the differences in the water flow will be small. If there is a need for knowing the amount of suspended particles in future measurement cases, tests with more realistic sediments should be performed.

3.5 SUMMARY

In this section, four off-the-shelf sensors have been tested. All the distance measuring sensors have been discarded due to critical limitations. While exploring the sensors several insights have been gained. In conclusion; we are not able to use a simple low-cost sensor for our application in a satisfactory manor.

4 MODULAR SONAR

From the previous section, we have learned that we need a prototype that we can adapt to underwater conditions. This is therefore set as a requirement and preferred end-point for this phase of the project. To reach this we have adapted a set-based way of thinking where we split the next prototype into sections that will be designed, built and tested in separate cycles. This desired end-point is to have a working prototype of a sonar in which we can alter the nature of the signal to fit our applications and can access all received data. The development of this prototype as well as testing will be presented. In this section, more theory will be presented as it is an important foundation for later calculations and choices of parameters.

4.1 THEORY

Sonar which is originally an acronym for "Sound navigation ranging", is a technique to navigate, communicate and detect objects on or in water. Mechanical waves or sound waves are energy transmitted by alternating compression and rarefactions of the medium it is propagating in. This can be read by a sensor that detects local fluctuation in pressure. A passive sonar is a sensor that only picks up pressure fluctuation, like a hydrophone, while an active sonar first sends out a wave and then picks up the reflection, like a loudspeaker and a microphone in one.

4.1.1 SPEED OF SOUND

Speed of sound (c) is determined by density [kg/m^3] and bulk modulus [GPa] of the medium it is traversing.

$$c = \sqrt{B/\rho} \quad (3)$$

Where bulk modulus determines the resistance a medium has to compression, similar to Young's modulus (E) which determines the strain resistance of a solid material. Even though it reduces speed, an increase in density is often associated with such an increase in bulk modulus that the speed is actually increased. An example of this is the fact that sound travels 14 times faster in iron than in air, even though iron is much denser, due to the larger increase in bulk modulus.

4.1.2 REFLECTION

Acoustic Impedance (Z) is the measure of the opposition a system has to acoustic flow. It is given as the function

$$Z = \rho * c = \sqrt{\rho * B} \quad (4)$$

with the unit of rayl or [$Pa*s/m$]. To explain the mechanism behind a wave reflection, we will consider the reflection and transmission of an incident wave on a normal plane boundary.

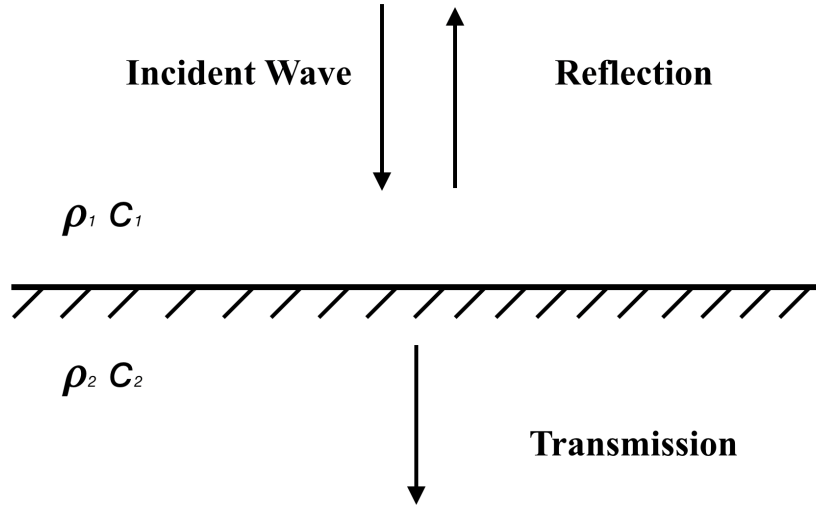

Figure 4.1: Reflection and transmission of an incident wave on a normal boundary

The reflection coefficient (R_s) is ratio of the stress (or pressure) amplitude of the incident wave which makes a reflected wave. R_s has a value between -1 and 1, where a negative sign represents a 180 degree phase shift.

$$R_s = \frac{\tau_r}{\tau_i} = \frac{Z_2 - Z_1}{Z_2 + Z_1} = \frac{\rho_2 c_2 - \rho_1 c_1}{\rho_2 c_2 + \rho_1 c_1} \quad (5)$$

The transmission coefficient (T_s) has a value between 0 and 2, thus will never give a phase shift, but can actually increase the amplitude. It represents the ratio of the stress amplitude transmitted to the second medium. The relative angle of the plane boundary and the incident wave is also relevant, but will not be further discussed at this point.

$$T_s = \frac{\tau_r}{\tau_i} = \frac{2Z_2}{Z_2 + Z_1} = \frac{2\rho_2 c_2}{\rho_2 c_2 + \rho_1 c_1} \quad (6)$$

4 MODULAR SONAR

21

Medium	Density (kg/m ³)	Velocity (m/s)	Impedance (kg m ⁻² s ⁻¹)
Air	1.3	330	0.4×10 ³
Water	10 ³	1.5×10 ³	1.5×10 ⁶
PVDF	1.8×10 ³	2.2×10 ³	2.5×10 ⁶
Perspex	1.2×10 ³	2.7×10 ³	3.2×10 ⁶
Quartz	2.6×10 ³	5.7×10 ³	1.5×10 ⁷
PZT (ceramic)	7.5×10 ³	3.8×10 ³	3×10 ⁷
Stainless steel	5.8×10 ³	3.3×10 ³	4.7×10 ⁷

Figure 4.2: Acoustic material data on common materials from Regtien & Dertien (2018)

4.1.3 SOUND LEVEL MEASUREMENT

When measuring sound levels, two scalars are often used; Sound Pressure Level (SPL) and Sound Intensity Level (SIL). SIL is a figure of how much energy is transformed to sound waves per area. This is independent of the medium the sound is to traverse and can be calculated by parameters given by the source. SPL is the experienced alternating pressure at a certain point relative to a wave source. The loudness at a certain distance from a speaker for instance. When measuring the transmission sensitivity of an echo source, the unit tells how much pressure is generated per voltage at a certain distance from the source.

In the context of acoustic measurements, the numbers are often impractically extreme. To make this simpler it is common to use the decibel scale. When we use decibels in the context of water acoustics, 1 μ Pa is used as the reference value in water, as opposed to 20 μ Pa in air.

$$B = 20 \log_{10} \frac{SPL}{1 \mu Pa} \quad (7)$$

4.1.4 ABSORPTION

The absorption of a sound wave is determined by the viscosity of the medium. The absorption of sound in water depends on properties such as salinity, temperature and acidity, as well as the frequency and depth of the propagating wave. Because higher frequencies represent more pressure fluctuation per time unit, higher frequencies will be more vulnerable to a higher viscosity. There are three common algorithms to calculate absorption. We have used Ainslie & McColm (1998) to calculate the absorption in the table below. The calculations show that the figures are insignificant at our ranges and salt levels, so we will not go deeper into the underlying physics of this phenomena.

4 MODULAR SONAR

22

Transmitted Frequency	200 kHz
Temperature	4 °C
Depth	10 m
pH	8
Salt in fresh water vs oceanic water	0 ppt / 35 ppt
Sound pressure loss (Ainslie and McCollm, 1998)	16.981 dB/km / 45.153 dB/km

Table 1

4.1.5 DISSIPATION

A mechanical wave will propagate with an angle. Typically 5 - 15 degrees. As the signal traverse, the signal area will increase thus energy density will decrease. This dispersion energy loss is significant and must be considered also at small ranges. L is the distance from the source to the target in meters, and ϕ is the cone angle.

$$\delta = \frac{1}{\pi(\tan(\phi/2)2L)^2} \quad (8)$$

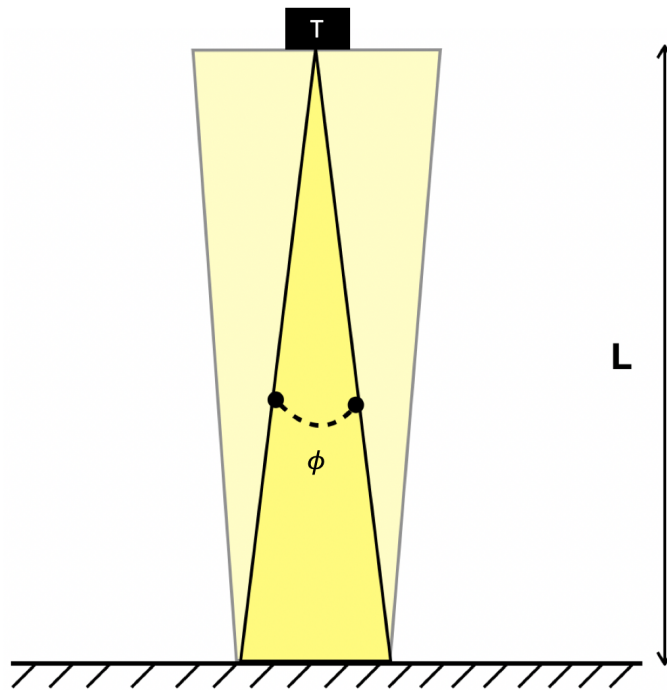

Figure 4.3: Illustration of wave dissipation

4.2 PROTOTYPE

In this subsection the different part of the prototype will be introduced, and the development of them will be presented. The sonar prototype consist of three parts; a transducer, an

4 MODULAR SONAR

23

oscilloscope and an Analog Interface Board.

4.2.1 TRANSDUCER

The transducer is the unit that will emit the sound pulses and receive the reflected response. The simple low-cost transducer was found in a storage at Norbit's facilities, and has therefore an unknown name and manufacturer. The data presented of the unit is the result of analysis.



Figure 4.4: The transducer provided by Norbit.

In figure 4.5 we can see the conductive response (G) of the transducer at different frequencies. Note that this test was done submerged in water, as the response will be different in the air. Conductance indicates how much power (P) that will be emitted as sound waves at a given voltage (U). The relationship is given by equation 9.

$$P = G * U^2 \quad (9)$$

From the plotted response it can be read that the transducer will work best at 200kHz, because it will have the highest power-to-voltage ratio. Further, we can see that the bandwidth of the sensor is small. This makes it more resistant for noise at other frequencies, but arguably less versatile. With that said the transducer has a secondary peak at 80 kHz, which can be used if we want to explore a surface with two different frequencies.

4 MODULAR SONAR

24

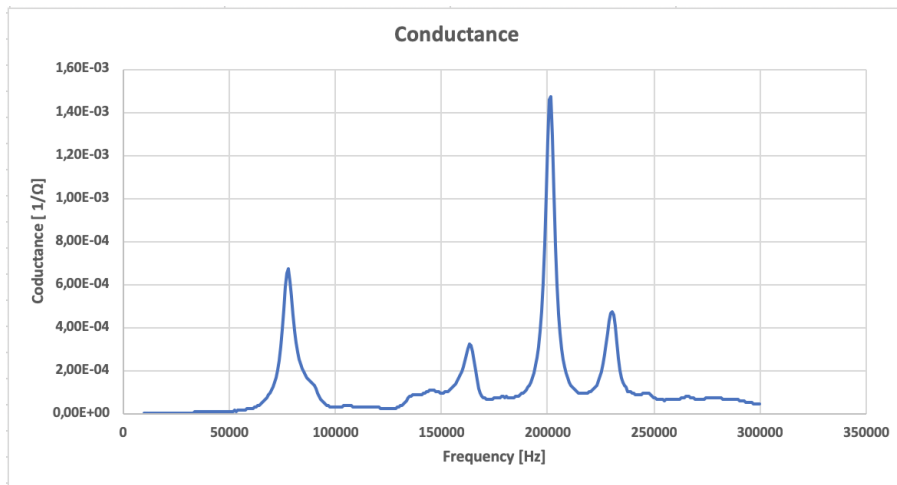

Figure 4.5: Conductance of transducer.

The name of the transducer is unknown, so to obtain crucial information of the sensor we had to analyze it. The steps of the analysis will not be presented. The acquired information is listed in table 2.

Dimensions	D =42 mm, w = 25mm	Main working Frequency	200 kHz
Weight	100g	Conductance at main frequency	0.001471263 1/Ω
Cone Angle	14°	Impedance at main frequency	680 Ω
Transmitting sensitivity [dB]	158 dB μ Pa/V at 1m	Receiving sensitivity [dB]	-202 dB V/μ Pa
Transmitting sensitivity	79.4 E6 μ Pa/V at 1 m	Receiving sensitivity	7.9432E-11V/μ Pa

Table 2: Relevant data on the transducer captured through analysis.

4 MODULAR SONAR

25

4.2.2 OSCILLOSCOPE

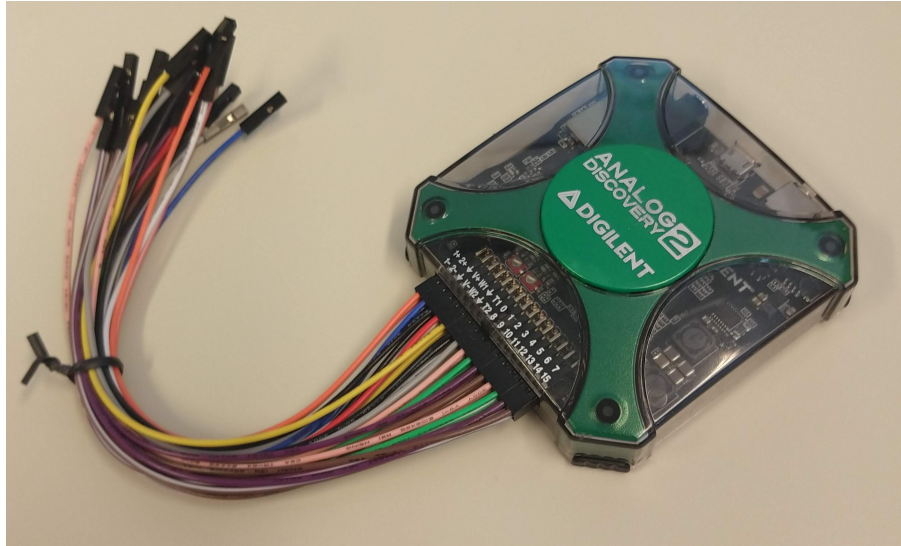

Figure 4.6: The oscilloscope: the Analog Discovery 2 board

To make a working prototype of a sonar we would need one unit to generate waves and read the response. For this, we used the Analog Discovery 2 board which is a pocket-sized and low-cost oscilloscope. With this oscilloscope, it is easy to change all parameters and adapt it to different prototypes and applications. It can later be replaced by a simple specialized circuit, if we are to optimize for size, simplicity or cost. The maximum voltage amplitude of the signal sent from the oscilloscope board is 5 V. Using the oscilloscope directly connected to the transducer was quickly tested. The generated and read signal can be studied in figure 4.7.

4 MODULAR SONAR

26



Figure 4.7: The oscilloscope interface while emitting and receiving signals.

The bottom half shows a 200kHz, 5V signal being generated for 1 ms followed by a 20 ms wait. The top half is the read signal which is the direct generated signal but no notable response. These parameters were suggested by professionals at Norbit, but different intervals were also tested with the same result. At this point, the test was done in air at 2 m distance from the plane surface. At an approximate speed of sound at 343 m/s, a response was expected at about 12 ms. This could not be found. Later when our knowledge of sonars in different mediums had increased, the test was repeated submerged in water with an equal result.

4.2.3 ANALOG INTERFACE BOARD

The amplitude difference in transmitted and received signal represents a challenge as it is in a single circuit. Both signals must be amplified to get readable data, but if the amplified pulse signal goes directly to the receiver, the oscilloscope could be harmed by the high voltage. To solve this, professionals at Norbit suggested making an Analog Interface Board (AIB). In figure 4.8 we can see a quick sketch of a proposed AIB. The professionals at Norbit was unsure of suitable parameters for the different components and significance of each part of the circuit. A knowledge gap in circuit design was identified and bridged with iterative prototyping of the circuit. Rapid prototypes were produced with a regular breadboard and the different parts were tested. The conclusion was that all the mentioned parts were vital.

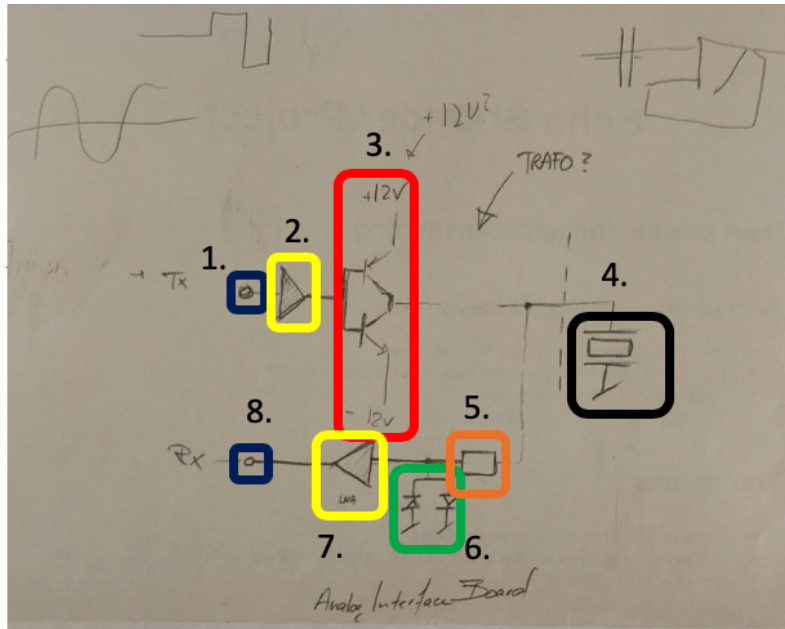

Figure 4.8: AIB Circuit Design sketch

Index	Name of Circuit Part	Purpose or function
1.	Tx	Input of generated wave from oscilloscope.
2.	Amplifier	Increase the voltage of the generated wave
3.	To BJT-diodes (PNP and NPN) in parallell	Increase the current of the generated signal and prevent reflected signal to go back to Tx
4.	Transducer I/O	Here the transducer is connected. This part will receive generated wave, and transmit the echo response.
5.	Resistor	This resistor makes part of the generated signal go out to the transducer, but it also dampens the echo response signal. Balancing this correctly is important.
6.	To opposite directed diodes in parallell connected to ground.	Cut signal voltage over a certain threshold to ultimately protect part 8.
7.	Amplifier	Increase the voltage of echo respons signal.
8.	Rx	Output to the oscilloscope.

Table 3: This table explains how the different parts of the first AIB circuit sketch work.

A more extensive AIB circuit which can be seen in figure 4.9, was designed and built. Some minor component changes were done iteratively. The result is a circuit that has a gain of both the Tx-signal and Rx-signal of 10, while protecting the Rx for voltages higher than 0.7 V. The final component prototype can be seen in figure 4.10.

4 MODULAR SONAR

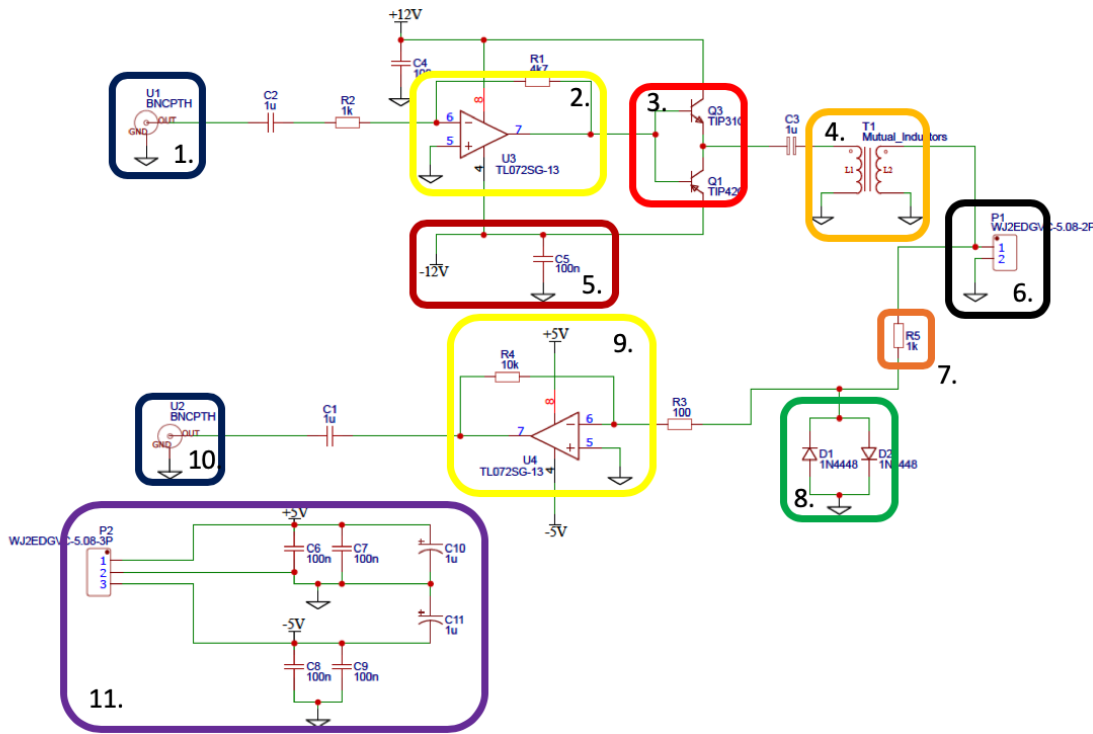

Figure 4.9: Circuit of the Analog Interface Board

Index	Name of Circuit Part	Purpose or function
1.	Tx	Input of generated wave from oscilloscope.
2.	Amplifier	Increase the voltage of the generated wave
3.	To BJT-diodes (PNP and NPN) in parallell	Increase the current of the generated signal and prevent reflected signal to go back to Tx
4.	Transformer	Increase the voltage of the generated wave. This part was not utilized in the working prototype.
5.	Negative Voltage supply in parallell with capacitor	Supply circuit part 2 and 3 with negative voltage. The capacitor is there even out the current the circuit pulls, thus counteracting the consequent noise. The corresponding positive voltage supply have an equal purpose.
6.	Transducer I/O	Here the transducer is connected. This part will receive generated wave, and transmit the echo respons.
7.	Resistor	This resistor makes part of the generated signal go out to the transducer, but it also dampens the echo response signal. Balancing this correctly is important.
8.	To opposite directed diodes in parallell connected to ground.	Cut signal voltage over a certain threshold to ultimately protect part 9.
9.	Amplifier	Increase the voltage of echo respons signal.
10.	Rx	Output to the oscilloscope.
11.	Auxiliary voltage supply circuit	Provide voltage supply for circuit part 2, 3 and 8. The capacitor is there even out the current the circuit pulls, thus counteracting the consequent noise.

Table 4: This table explains how the different parts of the AIB circuit work.

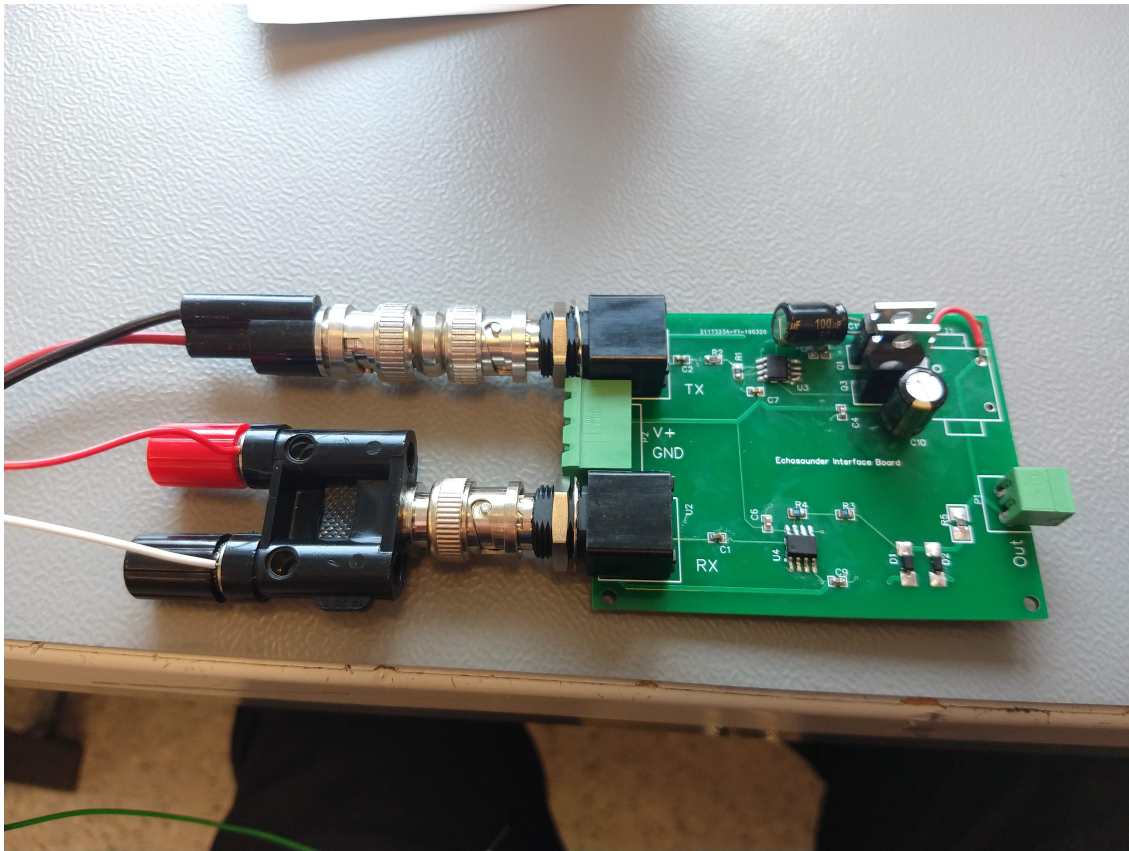

Figure 4.10: Final prototype of the Analog Interface Board

4.3 TEST

The modular Sonar was put together with the AIB, the transducer, an external power supply and the oscilloscope with a connected computer to read the response directly. This test aimed to measure the different response values of our sonar prototype. As well as to find useful values on pulse amplitude and power supply.

4 MODULAR SONAR

30

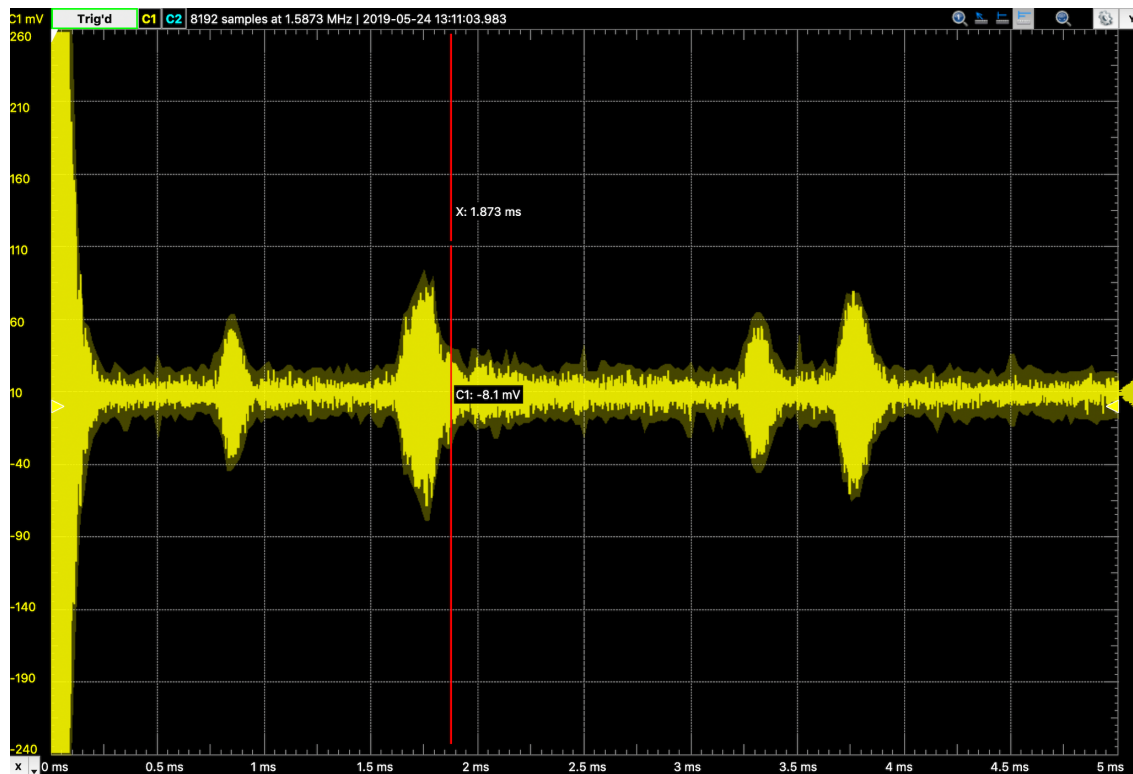

Figure 4.11: The echo response in tank.

The transducer was submerged in a rectangular tank with a length of 135 cm and a width of 22 cm, as can be seen in figure 4.12. The depth of the water was 7.3 cm. In figure 4.11 the received signal from the transducer is shown. The first 0.1 ms is the emitted pulse as well as the aftermath of the vibration of the generated pulse. This represents a minimum range of 5 cm. This aftermath will be dependent on the transducer and emitted signal, but can be mitigated by adding a single resistor between the two wires in the transducer.

At 0.7 ms echo-response 1 is detected. The echo is actually an unintended reflection from a 4 mm thick polymer thread in the middle of the tank. At 1.75 ms echo-response 2 from the opposed wall of the tank is detected. Echo responses 3 and 4 are secondary echos as illustrated in figure 4.12. This test was primarily useful to get familiar with the sonar as well as setting parameters for the power supply.

4 MODULAR SONAR

31

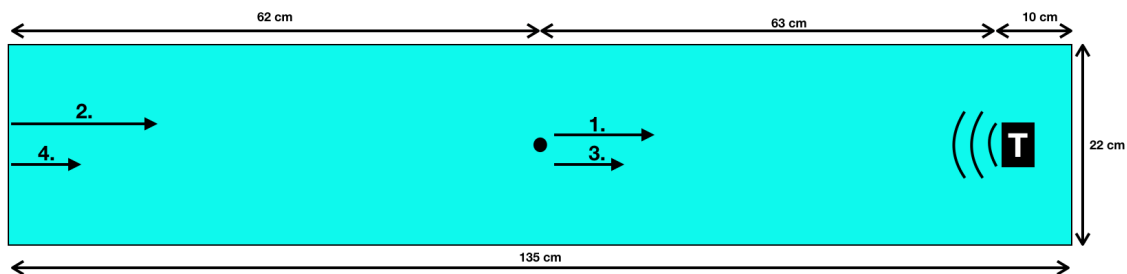

Figure 4.12: Schematic of the different echos

4.3.1 CALCULATIONS, COMPARING PRACTICE AND THEORY

In further application, we need to be able to choose correct transducers and set appropriate parameters to get satisfying measurements in the future. To compare practice and theory we set up a test to get the maximum reflection, so that we can compare it to simple calculations. The relation between parameters and response values can be explained by equation 11. This simple equation includes the effects that are considered relevant with this simple setup.

$$V_{in} = V_{out} \frac{G_{in} G_{out} T_{sens} R_{sens} R_s}{2L} \quad (10)$$

For the test, we put an acrylic plate with a thickness of 6mm at 63 cm from the transducer. The angle of the transducer was accurately set normal to the surface to get a maximum reading. The response of peak-to-peak value of ~ 350 mV can be seen in figure 4.13.

4 MODULAR SONAR

32

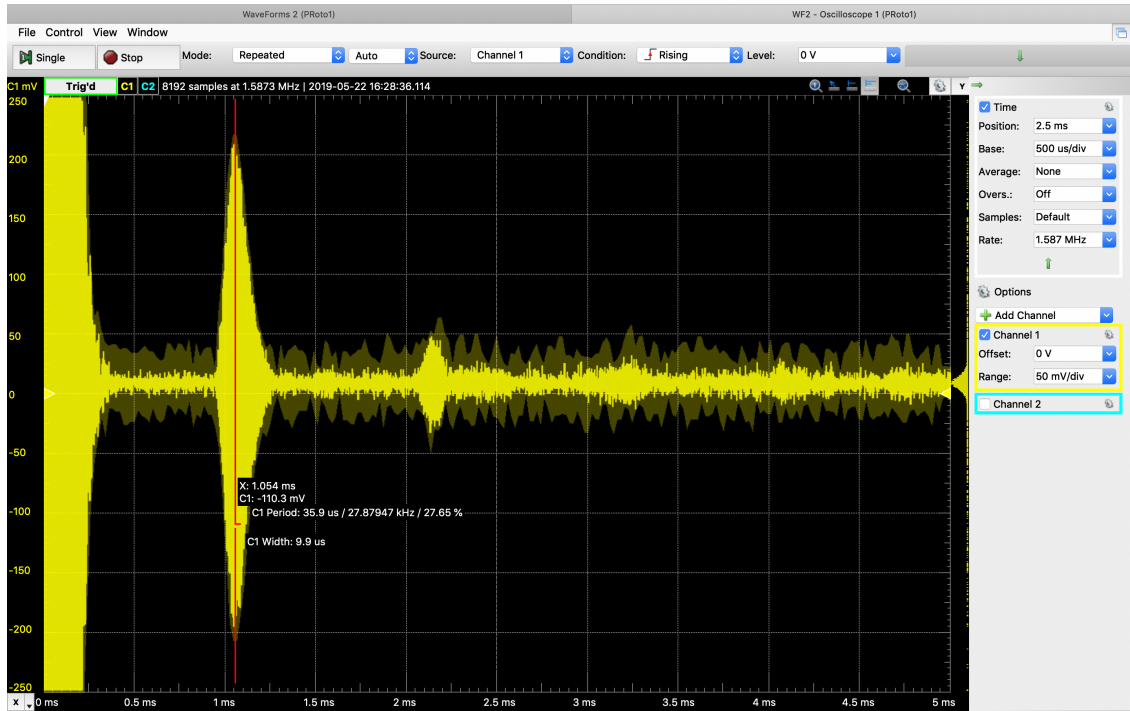

Figure 4.13: Maximum echo response at 63 cm

Z_{acryl}	Acoustic Impedance	3.5 [MPas/m]
Z_{water}	Acoustic Impedance	1.48 [MPas/m]
R_s	Reflection Coefficient	0.4056
R_s	Reflection Coefficient (Eq.6)	0.83870
V_{out}	Peak-to-peak voltage of pulse	2 V
G_{out}	Gain of transmitted signal	10
G_{in}	Gain of received signal	10
T_{sens}	Transmitting sensitivity	79.4 E6 μ Pa/V at 1 m
R_{sens}	Receiving sensitivity	7.9432E-11V/ μ Pa
L	Measuring distance	63 cm
V_{in}	Read peak-to-peak value, response	406 mV

Table 5: Parameters used for testing maximum reflection and calculated response with equation 11.

The calculated peak-to-peak V_{in} is 406mV. The difference of $\sim 16\%$ off the measured ~ 350 mV is probably due to unaccounted for loss in the circuit or unexpected absorption. Hence the equation will not give us the accurate relationship between the different prototype parameters, but it will give us a quick indication of constraints the different parameters put on each other. This will be very useful when setting requirements for a specific inspection case.

4 MODULAR SONAR

33

Note that we are using Transmitting sensitivity in the calculations with the unit [μ Pa/Vm] instead of [μ Pa/V at 1 m] because the only significant changes in the signal at this distance is a linear function of distance.

4.3.2 SONAR IN WATER WITH SUSPENDED PARTICLES

Furthermore, we wanted to explore how our sonar prototype worked in conditions with contaminated water. Because of the findings from the turbidity tests we knew that the turbidity was dependent on both water movement and global particle amount. We then set up a test with the aim to learn two things. Firstly find out if the sonar is vulnerable to suspended particles when operating at 200kHz. Secondly to find out if there was a dependent relationship between the turbidity measured at one point and the maximum range of the sonar. The test was performed in the previously described water tank with 3.2 g/L suspended particles. To alter the amount of particles between the transducer and the target plane, the water was stirred. The test was performed two times with different positions of the turbidity measurement relative to the transducer, 2cm and 22cm respectively. The results can be seen in figure 4.14.

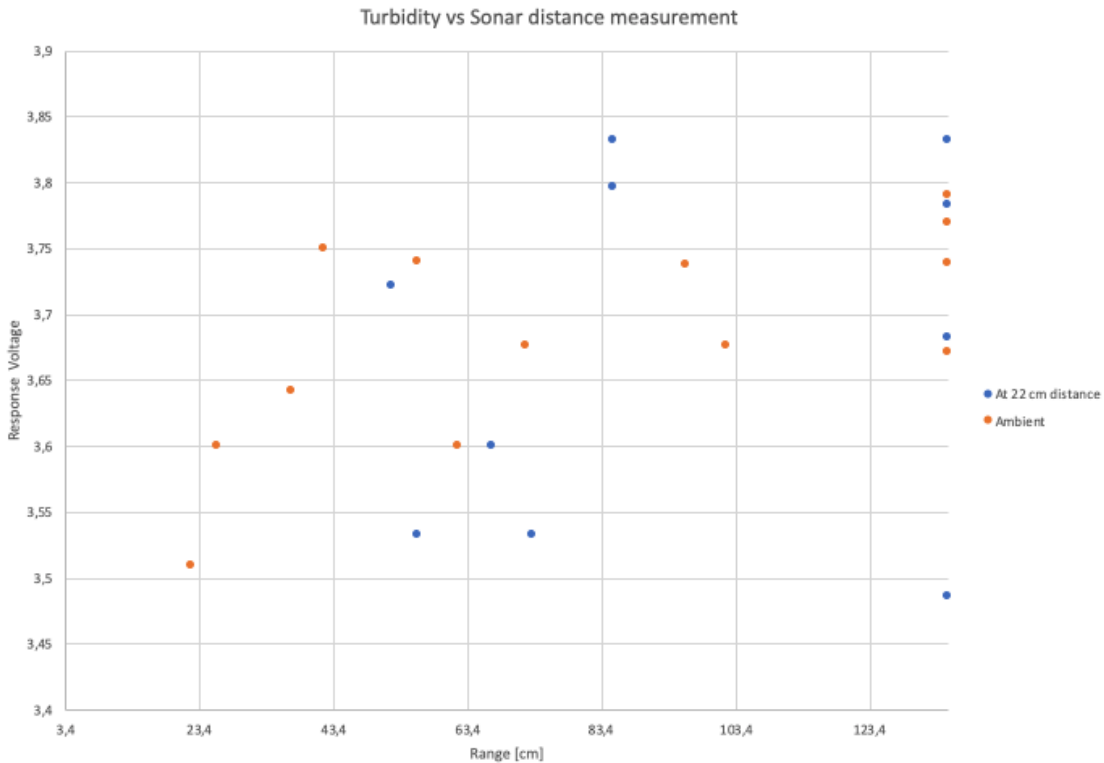

Figure 4.14: Relationship between sonar maximum range and turbidity measured at two different points relative to the transducer.

The result show us that the sonar is vulnerable too suspended particles of this kind when

4 MODULAR SONAR

34

operating at 200kHz. When the amount of particles is too high, the response is reduced to scatter, and we do not get false positive readings. To determine if there might be a dependent relationship between measured turbidity and maximum range is hard to say from the performed test. A relationship may be indicated in the plot, but the high variance of the turbidity response, as previously experienced, introduces a high degree of uncertainty.

The fact that suspended particles does not give false positive readings, eliminates the immediate need for determining the maximum range from a secondary sensor. Hence it was decided not to pursue this further at this point.

4.3.3 PROPERTIES OF THE FINAL PROTOTYPE

The amount of data storage is highly dependent on the chosen sampling rate as well as pulse frequency, which should be chosen according to the data resolution requirement of the inspection case. With our general set parameters of the data, requirements are as follows.

Amount of data produced per minute	96Mb / 12MB
Amount of data per sample	16bit / 2B
Practical sample rate with a 200kHz transducer	500kHz
Sample receiving duration at about 15 m range	20ms
Duration of transmitted pulse	100 μ s
Amount of data per measurement	160kb / 20 kB
Assumed measurement frequency	10 Hz

Table 6: Estimated data storage consumption of the modular sonar

The sum energy requirement	~ 3.8 W
Transmitting pulses with 10Hz	~ 1 mW
Oscilloscope	~ 2.5 W
AIB	~ 100 mW
Raspberry Pi 3	1.2 W

Table 7: Estimated energy consumption of the modular sonar

The energy requirements are mostly rough estimates by professionals at Norbit. A Raspberry Pi is in this case used as an example of a microcontroller that stores the data. As of yet; this is not a part of the working prototype. The modular sonar is made in such a way that it is adaptable to a wide set of measuring cases, therefore it is not at all optimized for energy or data storage consumption. These requirements are not global for low-cost sonars, but for this prototype at this point in time.

4.3.4 RESULTS

The key results and findings from the tests performed with the sonar are listed below.

- The sonar prototype can accurately measure distances underwater.

4 MODULAR SONAR

35

- We have obtained a mathematical relationship between parameters and measured response values in a lab environment.
- The sonar is vulnerable to a form of suspended particles while operating at 200kHz.
- High amounts of suspended particles does not create false positive readings but reduces the reflection to noise.
- There may be an obtainable relationship between turbidity and maximum range.

4.4 CONCLUSION

Through testing, we have learned that we can measure underwater distances with a low-cost modular sonar. We have also learned that the sonar is vulnerable to a form suspended particles when working at 200kHz, but does not create false positive readings. With the possibility of altering all parameters such as transducers, intensity and frequency, this sonar can be adapted to a wide range of measuring cases. We view the results as promising and further development will be discussed in Future work.

5 EMERGING REQUIREMENTS

Throughout this project, we have tested several ways to determine the surrounding dimensions. Exploring the solution space by wayfaring has given insight into useful limitations and requirements to the solution. As there is a very limited amount of low-cost sensor options when it comes to underwater distance measurements, we have tried to use low-cost sensors in new ways. Kriesi et al. (2016) suggests that letting insights from exploring setting dynamic requirements, will lead to more innovative and radical solutions.

5.1 DATA REQUIREMENTS

Based on interviews with engineers in Trønder Energi, they are not interested in determining the size and location of major obstructions or collapses, but to know the state of their tunnels. In this, they would like to inspect the amount and maybe even type of sediments accumulated in their water conveyors. Hence, the solution must in some way reveal the amount and location accumulated sediment in the water conveyor. As this requirement was discovered early in the project, it set an important direction for the following idea exploring.

5.2 SENSOR REQUIREMENTS

Starting the project, it was found through research that low-cost sensors for underwater measurements are nearly nonexistent on the market. And those which exist have critical shortcomings such as data availability. It was concluded after testing that low-cost TIF sensors are not possible to utilize underwater. The barriers being submerging the sensor into water, measuring through water or measuring through a waterproof casing. From theory, we know that it is possible to cross the identified barriers with the utilized physical measuring principles. The problem with the tested sensors was signal strength, signal nature or the limited access to received data. The solution needs to be able to cross these barriers. This was discovered midway in the project and set the end-point to be a modular general use low-cost sonar. A solution where we would be able to control all parameters to cross the mentioned barriers.

5.3 PULSE REQUIREMENTS

Results from sonar tests show that particles suspended in the water between the transducer and reflective surface, effects the distinctness of the reflected echo. In this, there are three relevant variables in play, namely the number of particles in the liquid, type of particles (determining signal absorption and particle buoyancy) and turbulence (determining how the particles distribute in the liquid). To be able to do underwater measurements with a sonar we need to have a pulse that has a high enough intensity or a long enough wavelength to traverse water with suspended particles. To determine the amount and type of particles in real water conveyors, more tests must be performed, and the sonar adapted.

6 DISCUSSION AND FUTURE WORK

6.1 RESULTS AND COMPARISON

In this project thesis, four ways of determining distance underwater and one way to determine liquid composition have been designed, built and tested. These tests have given insight into limitations, application fields and requirements. In the table below the measurement methods are compared in terms of feasibility for measuring dimensions of a liquid environment.

Sensor or concept	Ultrasonic	LIDAR	RADAR	Modular Sonar
Measurement principle	TIF	TIF	TIF	TIF
Off-the-shelf	Yes	Yes	Yes	No
Minimum range	4 cm	5 cm	33 cm	Dynamic
Maximum range	4 m	40 m	2 m	Dynamic
Directly submerged into water	No	No	No	Yes
Measure distances through water	No	Yes	No	N/A
Measure distances through casing	No	Yes	No	N/A
Measure distances through water and casing	-	No	-	N/A
Vulnerable to suspended particles in water	-	Yes	-	Yes
Gives false positives when suspended particles in water	-	Yes	-	No
All parameters are controllable	No	No	No	Yes
All received data is accessible	No	No	No	Yes
Conclusion	Not Suitable	Not Suitable	Not Suitable	Suitable

Figure 6.1: Summary of TIF-sensors results

We could not find any sufficient off the shelf way to do distance measurements underwater. A prototyping foundation for a modular sonar was made to meet emerging requirements. With the hope that more rapid design iterations can be done from here. The key difference is having access to raw data, as well as the option to change parameters that determine the characteristics of the measurement.

6.2 METHOD

This project has been revealed to be demanding in fields that are not at the core knowledge of a mechanical engineer student. The Wayfaring Method has been used to capture insights about a specific problem, but maybe more about the mechanism of different solutions. Early on in this project the highly adaptable electronic TIF measurement principle was prioritized, and the path guided us to new sensors with the same principle. These sensors are in principle very adaptable with a wide range of possibilities. But as the possibilities increase, so does the complexity and demand for knowledge. One of the strengths with the Wayfaring Method is that it efficiently guides you through the solutions space on a relevant path, by quickly testing low-resolution prototypes. As the prototypes' complexity has been at the core of the prototypes function, it has been proven hard to lower the resolution to increase the speed. Even at the earliest cycles. The result is a slower development of the rapid prototypes,

6 DISCUSSION AND FUTURE WORK

38

and therefore a slower progress through the solution space. This ultimately led to a lower probability of finding the global optimum Kriesi et al. (2016).

As it has been hard to lower the resolution of the prototypes, we have adjusted the resolutions of the tests. Gradually increasing their complexity, when they have given promising results. An example of this is when we tested the LIDAR sensor separately, proving that it could, in fact, both measure through water and through a polymer casing, before making a time consuming waterproof casing. This way of thinking was learned when we built a waterproof casing and submerged the RADAR in water, before testing it from air on the water surface, which would have saved us time.

The main barriers of prototyping speed and therefore the speed of gaining insights, have been the hazardousness of the measuring environment and required knowledge to develop the complex prototypes. The test environment barrier has been addressed by gradually increasing hazardousness of the environment. The knowledge barrier has been addressed by identifying knowledge gaps and bridging them by smaller prototype tests. Typically by testing subsystems separately, such as different parts of the AIB circuit. Even though the development of prototypes may have been slower than optimal, when using the wayfaring method, one could argue that the method facilitates the developers to embark on solutions that are not limited to their previous skill set, as the aim of the whole journey is to learn. And in this way increase the probability that the developers will find 'the next big idea' Steinert & Leifer (2012).

The methods built and tested are in many ways similar as they are all electronic TIF sensors. This arguably premature commitment to a small part of the solution space can be viewed as design fixation as addressed in Purcell & Gero (1996). Design fixation is likely to prevent the designer from reaching their full creative potential Youmans (2011), and many of the strengths of the Wayfaring Method are mitigated as you allow insights to guide you only in a limited set of directions. Design fixation is something one needs to be wary of and is something we would like to prevent in the next phase of the project. Specifically, we will try to use more physical prototypes when possible, and use the TrollLabs community more as a substitute for designing as a group, as suggested by Youmans (2011).

6.3 CONCEPT

The final concept is a foundation for prototyping time-of-flight sensors. With this foundation, one can switch modules to fit a specific measuring case. It is a highly versatile concept because the product developer has the possibility to change the nature of the measurement drastically and quickly. With this possibility, we believe it will be easier to perform rapid design iterations in future work as more insights regarding the test environment are captured. The concept will be further developed both generally and specifically to certain use cases.

6.4 LIMITATION OF RESEARCH

6.4.1 TEST ENVIRONMENT

The main weakness of this research is the lack of continuous gained knowledge of the actual problem environment. The complexity of the prototypes has demanded compromising of the

6 DISCUSSION AND FUTURE WORK

39

complexity of the test environment. Our tests have been performed in a lab environment and water tanks. No testing of distance measurements were conducted inside actual water conveyors. This was because most measuring methods were discarded before this testing stage, and the fact that the environment is hazardous and not easily accessible by its nature. The modular sonar would have been feasible to test in a more realistic environment, but the latest prototype was highly immobile and there was not sufficient time left at this point. Also, the type of sediment in water conveyor may be highly dependent on the specific conveyor and very different from the tested planting soil. How different real sediments compare is unknown. With the given time limitations one can argue that the focus should have been on less complex prototypes, to prevent the need to compromise the test environment.

6.4.2 METHODS TESTED

One could argue that we should have been more divergent from the start of the project and explored several measuring principles to get a wider perspective early and from there have a better understanding of the whole solution space. The type of sensor technology prioritized from start has been time-of-flight sensors. The exploratory testing has led us to different physical waves and application fields, but always with the same measuring principle. Completely different ways of measuring the amount of accumulated sediment were suggested early on, but as they were deemed more fragile and less versatile they were not prioritized. The only 'dark horse' we have tested as referred to in Steinert & Leifer (2012), is the turbidity sensor that introduces a completely different approach to the problem.

6.5 FUTURE WORK

Here we will present three bullet points that should be performed independently of the chosen concept for the next phase. The three next bullet points are potential future capabilities of the modular sonar. We envision two different main concepts to be chosen from. A pipe inspection AUV and sediment analysis AUV in a hydropower tunnel. Note that this is only what path we envision with the knowledge available at this point. This may change drastically when the exploring continues.

6.5.1 STORE READABLE DATA

In the last iteration of the working prototype, the data can only be read in real-time from a connected computer. This limits mobility as well as thorough data analysis. The first step will be to make a simple piece of software that stores data in a meaningful way. A reflection density plot may be an efficient way to visualize the data. In the next phase of the project data analysis will be more vital. The choice of data format and amount is a topic for exploring.

6.5.2 MAKE THE PROTOTYPE MORE MOBILE

Today the sonar is dependent on a computer as well as two external power supplies connected in series to be operational. This does not inhibit testing of the sonar in a lab environment, but it is a barrier for testing in more hazardous and realistic environments. As more parameters

6 DISCUSSION AND FUTURE WORK

40

are set and the sonar becomes more stable, the data logging software can be running on a connected microcontroller. A more general microcontroller like a Raspberry Pi at first, with the possibility to optimize to a more power-efficient or a computing powerful microcontroller over time. A more mobile power supply can have one power chord to improve mobility greatly or be battery-driven so that the prototype becomes fully mobile.

6.5.3 MAKE AN AUV TO PERFORM INSPECTIONS

To perform an inspection one will need a robust vessel that at all times can measure distances to the top and bottom of the water conveyer. This can be solved by multiple sensors and measured angles or a vessel that always have the same orientation. The vessel can be optimized for minimal size, maximum durability or other special measuring cases. The different modules of the sonar should be chosen depending on what is to be inspected.

6.5.4 DETERMINING MATERIAL AT DIFFERENT LEVELS

An advantage of having all data available with a TIF sensor is that the transit time is dependent on distance and will be independent absorption. The absorption gives us information about the average acoustical properties in a known distance from the transducer. The challenge is to determine the acoustical properties of the different layers of materials ahead. This can be solved in two ways. The simplest way is to assume uniform acoustic impedance in the medium ahead of the reflection surface. Then the only variable is the impedance of the reflective material, which can give us a strong indication of what the surface material is. In inspection cases where this assumption is correct, the method will provide sufficient answers.

In cases where the absorption of the medium is an unknown variable, caused for instance by suspended particles, there is a second possibility. That is to use multiple wavelengths. Longer wavelengths have a greater ability to penetrate materials. Having the modular sonar to send out a range of different frequencies may give us more accurate information about the different layers of materials in different measuring distances. Given a functioning data logging software we could determine the reflective material's impedance with the modular sensor with the current iteration, assuming uniform absorption in the water in between. Adding the functionality of multiple frequencies will demand that we acquire or make a transducer with several operating frequencies or several transducers with different frequencies.

6.5.5 DETERMINING SPEED AND LOCATION OF MEASUREMENTS

In water conveyer inspection a great problem outside the scope of this project is localization. Measuring dimensions are of low value if it is impossible to determine the position of the measurements. With a sonar, one can determine the relative speed of the environment by measuring the wavelength alteration of the echo caused by moving reflective surfaces (The Doppler effect). In this way, one could measure both the speed of the water flow and the vessel relative to the water conveyer. Combining this with an accelerometer and a gyroscope introduces the possibility to determine the locations of the measurements.

6 DISCUSSION AND FUTURE WORK

41

6.5.6 LEAK DETECTION BY HYDROPHONES

A leak in a water pipe generates noise, which can be detected and used for determining location. Acoustic leak detection has been proven to be effective Fantozzi et al. (1993), Fuchs & Riehle (1991) and Liston & Liston (1992) and are in common use in the water industry. Using the sonar as a passive hydrophone might be a suitable way to detect pipe leakages.

7 CONCLUSION

This project thesis has aimed to unveil sufficient methods to automatically inspect water tunnels and pipes. Through prototyping with rapid iterations; insights have been gained, and knowledge regarding the problem and possible solutions have been captured. The key variable identified of a water conveyor's status is the dimensions of the water flow in a conveyor. As this is the main variable, ways of measuring the amount of sediment in a water conveyor have also been tested. Through utilizing the exploratory approach of the Wayfaring Method the solution space has been efficiently mapped out. No low-cost off-the-shelf method to measure distances underwater were identified, where the relevant data was available. To solve this, a highly adaptable modular sonar was developed, showing promising results. The first phase of the future work will be to find a suitable format to store and analyze data, as well as building a mobile vessel from which one can perform inspections. Furthermore, the sonar can be developed in a number of different ways such as to do relative speed measurement or a multiple material layer analysis. The Wayfaring method has been proven effective in identifying and bridging knowledge gaps.

REFERENCES

44

REFERENCES

-
- Aasboe, E., Almankaas, J. S. & Pidic, A. (2017), ‘Development of a low-cost autonomous underwater vehicle (auv) for inspection of water-filled tunnels during operation’.
- Ainslie, M. A. & McColm, J. G. (1998), ‘A simplified formula for viscous and chemical absorption in sea water’, *The Journal of the Acoustical Society of America* **103**(3), 1671–1672.
- Berglund, A. & Leifer, L. (2013), ‘Why we prototype! an international comparison of the linkage between embedded knowledge and objective learning’, *Engineering Education* **8**(1), 2–15.
- Bråtveit, K., Bruland, A. & Brevik, O. (2016), ‘Rock falls in selected norwegian hydropower tunnels subjected to hydropeaking’, *Tunnelling and Underground space technology* **52**, 202–207.
- Fantozzi, M., Di Chirico, G., Fontana, E., Association, A. W. W. et al. (1993), Leak inspection on water pipelines by acoustic emission with cross-correlation method, in ‘AWWA 1993 Annual Conference’, AWWA, pp. 609–21.
- Fuchs, H. & Riehle, R. (1991), ‘Ten years of experience with leak detection by acoustic signal analysis’, *Applied acoustics* **33**(1), 1–19.
- Gerstenberg, A., Sjöman, H., Reime, T., Abrahamsson, P. & Steinert, M. (2015), A simultaneous, multidisciplinary development and design journey – reflections on prototyping, Vol. 9353, Springer Verlag, pp. 409–416.
- Kennedy, B. M., Sobek, D. K. & Kennedy, M. N. (2014), ‘Reducing rework by applying set-based practices early in the systems engineering process’, *Systems Engineering* **17**(3), 278–296.
- Kriesi, C., Blindheim, J., Bjelland, Ø. & Steinert, M. (2016), ‘Creating dynamic requirements through iteratively prototyping critical functionalities’, *Procedia CIRP* **50**(C), 790–795.
- Linjar, Asbjørn & Hofstad, K. (2018), ‘Vannkraft i store norske leksikon’.
URL: <https://snl.no/vannkraft>
- Liston, D. A. & Liston, J. D. (1992), ‘Leak detection techniques’, *Journal of the New England Water Works Association JNEWA* **6**, **106**(2).
- Mullen, L. J., Vieira, A. J., Herezfeld, P. & Contarino, V. M. (1995), ‘Application of radar technology to aerial lidar systems for enhancement of shallow underwater target detection’, *IEEE Transactions on microwave theory and techniques* **43**(9), 2370–2377.
- Norsk Vann, B. (2017), ‘Tilstandsvurdering av av kommunale vann- og avløpstjenester, bedrevann’.
URL: <https://bedrevann.no/pdf/bedreVANN2017.pdf>

REFERENCES

45

- Purcell, A. T. & Gero, J. S. (1996), 'Design and other types of fixation', *Design studies* **17**(4), 363–383.
- Regtien, P. P. & Dertien, E. (2018), *Sensors for mechatronics*, Elsevier.
- Sobek, Durward K., I., Ward, A. C. & Liker, J. K. (1999), 'Toyota's principles of set-based concurrent engineering', *Sloan Management Review* **40**(2).
- Steinert, M. & Leifer, L. (2012), "finding one's way": Re-discovering a hunter-gatherer model based on wayfaring', *International Journal of Engineering Education* **28**, 251–252.
- Thidemann, A. & Bruland, A. (1991), 'Reinforcement of hydro power tunnels', *SINTEF Report STF36 A* **91056**.
- Youmans, R. J. (2011), 'The effects of physical prototyping and group work on the reduction of design fixation', *Design Studies* **32**(2), 115–138.

A ARDUINO CODE ULTRASONIC MODULE.

46

A ARDUINO CODE ULTRASONIC MODULE.

```
const int trigPin1 = 9;
const int echoPin1 = 10;
long duration1;
int distinCM1;
int lastValue1 = 0;

void setup()
{
  pinMode(trigPin1 , OUTPUT);
  pinMode(echoPin1 , INPUT);
  Serial.begin(9600);
}
void loop()
{
  delay(50);
  digitalWrite(trigPin1 , LOW);
  delayMicroseconds(2);
  digitalWrite(trigPin1 , HIGH);
  delayMicroseconds(10);
  digitalWrite(trigPin1 , LOW);
  duration1 = pulseIn(echoPin1 , HIGH);
  distinCM1 = duration1 * 0.034 / 2;
  if (distinCM1 > 800) {                               % To reduce noise
    distinCM1 = lastValue1;
  }
  Serial.print(distinCM1);
  Serial.print('\n');
  lastValue1 = distinCM1;
}
```

B ARDUINO CODE FOR LIDAR TESTS

```
#include <Wire.h>
#include <LIDARLite.h>
#define SENSOR      A0
float voltage;
LIDARLite myLidarLite;

void setup()
{
  Serial.begin(9600);
  pinMode(SENSOR,INPUT);
  myLidarLite.begin(0, true); // Set configuration to default and I2C to 400
myLidarLite.configure(0); // Change this number to try out alternate configur
}

void loop()
{
  Serial.print(" ");
  Serial.print(myLidarLite.distance());
  Serial.print(" ");
}
}
```

C ARDUINO CODE FOR TURBIDITY MEASUREMENTS

```
#include <Wire.h>
#define SENSOR      A0
float turbidity;
void setup()
{
  Serial.begin(9600);
  pinMode(SENSOR,INPUT);
}

void loop()
{
  voltage=0.004888*analogRead(SENSOR); //in V
  turbidity=-1120.4*voltage*voltage+5742.3*voltage-4352.9; //in NTU
  if((voltage >=2.5)&(turbidity >=0))
  {
    Serial.print(voltage);
    Serial.print(" ");
    Serial.println(turbidity);
  }
  delay(2000);
}
```

D RISK ASSESMENT FOR METALLOGRAPHY LAB

	Kartlegging av risikofylt aktivitet	Utarbeidet av	Nummer	Dato	
		HMS-avd.	HMSRV2601	22.03.2011	
		Godkjent av		Erstatter	
		Rektor		01.12.2006	

Enhet: Institutt for Maskinteknikk og Produksjon

Dato: 08.06.2019

Linjeleder: Martin Steinert

Deltakere ved kartleggingen (m/ funksjon): Johan Christian Wigen Hjorth, student

(Ansv. veileder, student, evt. medveiledere, evt. andre m. kompetanse)

Kort beskrivelse av hovedaktivitet/hovedprosess: Prosjektoppgave student Johan Christian Wigen Hjorth. «*Development of a low cost under water distance measurement sensor*»

Er oppgaven rent teoretisk? (JA/NEI): **Nei**

«JA» betyr at veileder inntår for at oppgaven ikke inneholder noen aktiviteter som krever risikovurdering. Dersom «JA»: Beskriv kort aktiviteteten i kartleggingskjemaet under. Risikovurdering trenger ikke å fylles ut.

Signaturer:



Ansvarlig veileder: Martin Steinert



Student: Johan Christian Wigen Hjorth



ID nr.	Aktivitet/prosess	Ansvarlig	Eksisterende dokumentasjon	Eksisterende sikringstiltak	Lov, forskrift o.l.	Kommentar
1	Bruk av Trolllabs og Realiseringslab	JCWH	Romkort	Romkort		
1a	Bruk av roterende maskineri	JCWH	Maskinens brukermanual	Ukjent	Ukjent	
1b	Bruk av laserkutter	JCWH	Maskinens brukermanual	Ukjent	Ukjent	
1c	Bruk av 3D printer	JCWH	Maskinens brukermanual	Ukjent	Ukjent	
1d	Bruk av skjæreverktøy	JCWH	Ukjent			

 NTNU  HMS	Kartlegging av risikofylt aktivitet			Utarbeidet av	Nummer	Dato	
				HMS-avd.	HMSRV2601	22.03.2011	
				Godkjent av Rektor		Erstatter 01.12.2006	
1e	Bruk av sammenføyningsmidler (lim og lignende.)	JCWH	Produktets brukermanual og datablad	Datablad	Ukjent		
2	Tilstedeværelse ved arbeid utført av andre.	Andre	Andres HMSRV2601	Andres HMSRV2601	Prosessavhengig		
3	Eksperimentelt arbeid	JCWH	Egen risikovurdering- må gjøres for hvert enkelt eksperiment		Prosessavhengig		
4	Arbeid på PC	JCWH	Ukjent	Ukjent	Ukjent		

D RISK ASSESMENT FOR METALLOGRAPHY LAB



51

NTNU	Risikovurdering	Utarbeidet av	Nummer	Dato	
		HMS-avd.	HMSRV2601	22.03.2011	
HMS		Godkjent av		Erstatter	
		Rektor		01.12.2006	

ID nr	Aktivitet fra kartleggings-skjemaet	Mulig uønsket hendelse/belastning	Vurdering av sannsynlighet (1-5)	Vurdering av konsekvens:				Risiko-Verdi (menneske)	Kommentarer/status Forslag til tiltak
				Menneske (A-E)	Ytre miljø (A-E)	Øk/ materiell (A-E)	Om-dømme (A-E)		
1	Bruk av Trollabs workshop.								
1a-i	Bruk av roterende maskineri	Stor kuttskade	2	D	A	A	D	D2	Sørg for at roterende deler tilstrekkelig sikret/dekket. Vær nøye med opplæring i bruk av maskineri.
1a-ii		Liten kuttskade	3	B	A	A	A	B3	Vær nøye med opplæring i bruk av maskineri. Ikke ha løse klær/tilbehør på kroppen.
1a-iii		Klemskade	2	D	A	A	C	D2	Vær nøye med opplæring i bruk av maskineri. Ikke ha løse klær/tilbehør på kroppen.
1a-iv		Flygende spon/gjenstander	3	C	A	A	B	C3	Bruk øyevern og tildekk hurtig roterende deler (Fres og lignende.)
1a-v		Feil bruk-> ødelagt utstyr	3	A	A	C	A	A3	Vær nøye med opplæring i bruk av maskineri
1b-i	Bruk av laserkutter	Klemskade	2	D	A	A	C	D2	Vær nøye med opplæring i bruk av maskineri. Ikke ha løse klær/tilbehør på kroppen.
1b-ii		Brannskade	3	B	A	A	A	B3	Vær nøye med opplæring i bruk av maskineri. Bruk hansker ved håndtering av varme materialer.



D RISK ASSESMENT FOR METALLOGRAPHY LAB

52

NTNU		Risikovurdering							Utarbeidet av	Nummer	Dato	
									HMS-avd.	HMSRV2601	22.03.2011	
HMS									Godkjent av	Erstatter		
									Rektor		01.12.2006	
1b-iv		Brann	2	B	A	D	C	B2	Vær nøye med opplæring i bruk av maskin. Ha slukkeutstyr tilgjengelig			
1c-i	Bruk av 3D-printer	Brannskade	3	B	A	A	A	B3	Vær nøye med opplæring i bruk av maskin.			
1c-ii		Feil bruk-> ødelagt maskineri	3	A	A	C	A	A3	Vær nøye med opplæring i bruk av maskin.			
1d-i	Bruk av skjæreverktøy	Stor kuttskade	2	D	A	A	D	D2	Bruk skapre verktøy og riktig skjæreunderlag			
1d-ii		Liten kuttskade	3	B	A	A	A	B3	Bruk skapre verktøy og riktig skjæreunderlag			
1e-i	Bruk av samentøyningsmidler (lim og lignende.)	Eksposering på øyet	2	D	A	A	B	D2	Bruk øyevern, ha datablad tilgjengelig			
1e-ii		Eksposering hud	4	A	A	A	A	A4	Bruk hansker, ha datablad tilgjengelig			
1e-iii		Eksposering åndedrett	4	A	A	A	A	A4	Bruk åndedrettsvært/ god ventilasjon. Ha datablad tilgjengelig.			
1e-iv		Søl	4	A	B	A	A	A4	Ha papir/ rengjøringsmateriell tilgjengelig. Ha datablad tilgjengelig.			
2	Tilstedeværelse ved arbeid utført av andre.	Se andres risikovurdering om sikkerhet betviles.	3	C	C	C	C	C3	Hold et øye med hva som foregår rundt deg.			
3-i	Eksperimentelt arbeid	Epilepsianfall forårsaket av blinkende lys	1	C	A	A	D	C1	Spør deltagere om de har epilepsi			

D RISK ASSESMENT FOR METALLOGRAPHY LAB

53

NTNU  HMS	Risikovurdering							Utarbeidet av	Nummer	Dato	
								HMS-avd.	HMSRV2601	22.03.2011	
								Godkjent av Rektor		Erstatter 01.12.2006	
4	Arbeid på PC	Musearm	3	A	A	A	A	A3	Tøye etter lange programmerings- og skriveøkter. Veksle arbeidsform gjennom dagen		

Sannsynlighet vurderes etter følgende kriterier:

Svært liten 1	Liten 2	Middels 3	Stor 4	Svært stor 5
1 gang pr 50 år eller sjeldnere	1 gang pr 10 år eller sjeldnere	1 gang pr år eller sjeldnere	1 gang pr måned eller sjeldnere	Skjer ukentlig

Konsekvens vurderes etter følgende kriterier:



Gradering	Menneske	Ytre miljø Vann, jord og luft	Øk/materiell	Omdømme
E Svært Alvorlig	Død	Svært langvarig og ikke reversibel skade	Drifts- eller aktivitetsstans >1 år.	Troverdighet og respekt betydelig og varig svekket
D Alvorlig	Alvorlig personskade. Mulig uførhet.	Langvarig skade. Lang restitusjonstid	Driftsstans > ½ år Aktivitetsstans i opp til 1 år	Troverdighet og respekt betydelig svekket
C Moderat	Alvorlig personskade.	Mindre skade og lang restitusjonstid	Drifts- eller aktivitetsstans < 1 mnd	Troverdighet og respekt svekket
B Liten	Skade som krever medisinsk behandling	Mindre skade og kort restitusjonstid	Drifts- eller aktivitetsstans < 1uke	Negativ påvirkning på troverdighet og respekt
A Svært liten	Skade som krever førstehjelp	Ubetydelig skade og kort restitusjonstid	Drifts- eller aktivitetsstans < 1dag	Liten påvirkning på troverdighet og respekt

Risikoverdi = Sannsynlighet x Konsekvens

Beregn risikoverdi for Menneske. Enheten vurderer selv om de i tillegg vil beregne risikoverdi for Ytre miljø, Økonomi/materiell og Omdømme. I så fall beregnes disse hver for seg.

Til kolonnen "Kommentarer/status, forslag til forebyggende og korrigerende tiltak":

Tiltak kan påvirke både sannsynlighet og konsekvens. Prioriter tiltak som kan forhindre at hendelsen inntreffer, dvs. sannsynlighetsreducerende tiltak foran skjerpet beredskap, dvs. konsekvensreducerende tiltak.

NTNU  HMS/KS	Risikomatrise	utarbeidet av	Nummer	Dato	
		HMS-avd.	HMSRV2604	08.03.2010	
		godkjent av		Erstatter	
		Rektor		09.02.2010	

MATRISSE FOR RISIKOVURDERINGER ved NTNU

KONSEKVENSENS	Svært alvorlig	E1	E2	E3	E4	E5
	Alvorlig	D1	D2	D3	D4	D5
	Moderat	C1	C2	C3	C4	C5
	Liten	B1	B2	B3	B4	B5
	Svært liten	A1	A2	A3	A4	A5
		Svært liten	Liten	Middels	Stor	Svært stor
		SANNSYNLIGHET				

Prinsipp over akseptkriterium. Forklaring av fargene som er brukt i risikomatrisen.

Farge	Beskrivelse
Rød	Uakseptabel risiko. Tiltak skal gjennomføres for å redusere risikoen.
Gul	Vurderingsområde. Tiltak skal vurderes.
Grønn	Akseptabel risiko. Tiltak kan vurderes ut fra andre hensyn.

D RISK ASSESMENT FOR METALLOGRAPHY LAB

NTNU	Kartlegging av risikofylt aktivitet			Utarbeidet av	Nummer	Dato	
				HMS-avd.	HMSRV2601	22.03.2011	
HMS				Godkjent av		Erstatter	
				Rektor		01.12.2006	

Enhet: Institutt for Maskinteknikk og Produksjon

Linjeleder: Martin Steinert

Deltakere ved kartleggingen (m/ funksjon): Johan Christian Wigen Hjorth, student
(Ansv. veileder, student, evt. medveiledere, evt. andre m. kompetanse)

Kort beskrivelse av hovedaktivitet/hovedprosess: Masteroppgave student Johan Christian Wigen Hjorth. «Development of a low cost pipe leakage location device»

Er oppgaven rent teoretisk? (JA/NEI): **Nei**
«Ja» betyr at veileder innestår for at oppgaven ikke inneholder noen aktiviteter som krever risikovurdering. Dersom «Ja»: Beskriv kort aktiviteten i kartleggingskjemaet under. Risikovurdering trenger ikke å fylles ut.

Signaturer:

Ansvarelig veileder: Martin Steinert







Student: Johan Christian Wigen Hjorth





Dato: 17.01.2020

ID nr.	Aktivitet/prosess	Ansvarelig	Eksisterende dokumentasjon	Eksisterende sikringstiltak	Lov, forskrift o.l.	Kommentar
1	Bruk av Trolllabs og Realiseringslab	JCWH	Romkort	Romkort		
1a	Bruk av roterende maskineri	JCWH	Maskinens brukermanual	Ukjent	Ukjent	
1b	Bruk av laserkutter	JCWH	Maskinens brukermanual	Ukjent	Ukjent	
1c	Bruk av 3D printer	JCWH	Maskinens brukermanual	Ukjent	Ukjent	
1d	Bruk av skjæreverktøy	JCWH	Ukjent			

NTNU		Utarbeidet av		Nummer		Dato		
		HMS-avd.		HMSRV2601		22.03.2011		
HMS		Godkjent av		Erstatter		01.12.2006		
		Rektor						
Kartlegging av risikofylt aktivitet								
1e	Bruk av sammenføyingsmidler (lim og lignende.)	JCWH	Produktets brukermanual og datablad	Datablad	Ukjent			
2	Tilstedeværelse ved arbeid utført av andre.	Andre	Andres HMSRV2601	Andres HMSRV2601	Prosessavhengig			
3	Eksperimentelt arbeid	JCWH	Egen risikovurdering må gjøres for hvert enkelt eksperiment		Prosessavhengig			
4	Arbeid på PC	JCWH	Ukjent	Ukjent	Ukjent			

NTNU			Risikovurdering		Utarbeidet av	Nummer	Dato	
HMS					HMS-avd.	HMSRV2601	22.03.2011	
					Godkjent av	Erstatter		
					Rektor		01.12.2006	

ID nr	Aktivitet fra kartleggings-skjemaet	Mulig uønsket hendelse/ belastning	Vurdering av sannsynlighet (1-5)	Vurdering av konsekvens:				Risiko-Verdi (menneske)	Kommentarer/status Forslag til tiltak
				Menneske (A-E)	Ytre miljø (A-E)	ØK/ materiell (A-E)	Om-dømme (A-E)		
1	Bruk av Trollabbs workshop.								
1a-i	Bruk av roterende maskineri	Stor kuttskade	2	D	A	A	D	D2	Sørg for at roterende deler tilstrekkelig sikret/dekket. Vær nøye med opplæring i bruk av maskineri.
1a-ii		Liten kuttskade	3	B	A	A	A	B3	Vær nøye med opplæring i bruk av maskineri. Ikke ha løse klær/tilbehør på kroppen.
1a-iii		Klenskade	2	D	A	A	C	D2	Vær nøye med opplæring i bruk av maskineri. Ikke ha løse klær/tilbehør på kroppen.
1a-iv		Flygende spon/gjenstander	3	C	A	A	B	C3	Bruk øyevern og tildekk hurtig roterende deler (Fres og lignende.)
1a-v		Feil bruk-> ødelagt utstyr	3	A	A	C	A	A3	Vær nøye med opplæring i bruk av maskineri
1b-i	Bruk av laserkutter	Klenskade	2	D	A	A	C	D2	Vær nøye med opplæring i bruk av maskineri. Ikke ha løse klær/tilbehør på kroppen.
1b-ii		Brennskade	3	B	A	A	A	B3	Vær nøye med opplæring i bruk av maskineri. Bruk hansker ved håndtering av varme materialer.

				Risikovurdering				Utarbeidet av _____		Nummer _____		Dato _____	
								HMS-avd. HMSRV2601		22.03.2011			
								Godkjent av _____		Erstatler _____			
								Rektor _____		01.12.2006			

1b-iv		Brann	2	B	A	D	C	B2	Vær nøye med opplæring i bruk av maskin. Ha slukkeutstyr tilgjengelig
1c-i	Bruk av 3D-printer	Brannskade	3	B	A	A	A	B3	Vær nøye med opplæring i bruk av maskin.
1c-ii		Feil bruk-> ødelagt maskineri	3	A	A	C	A	A3	Vær nøye med opplæring i bruk av maskin.
1d-i	Bruk av skjæreverktøy	Stor kuttskade	2	D	A	A	D	D2	Bruk skapre verktøy og riktig skjæreunderlag
1d-ii		Liten kuttskade	3	B	A	A	A	B3	Bruk skapre verktøy og riktig skjæreunderlag
1e-i	Bruk av sementøyningsmidler (lim og lignende.)	Eksposering på øyet	2	D	A	A	B	D2	Bruk øyvern, ha datablad tilgjengelig
1e-ii		Eksposering hud	4	A	A	A	A	A4	Bruk hansker, ha datablad tilgjengelig
1e-iii		Eksposering åndedrett	4	A	A	A	A	A4	Bruk åndedrettsvært/ god ventilasjon. Ha datablad tilgjengelig.
1e-iv		Søl	4	A	B	A	A	A4	Ha papir/ rengjøringsmaterieill tilgjengelig. Ha datablad tilgjengelig.
2	Tilstedeværelse ved arbeid utført av andre.	Se andres risikovurdering om sikkerhet betviles.	3	C	C	C	C	C3	Hold et øye med hva som foregår rundt deg.
3-i	Ekspérimentelt arbeid	Epilepsiantfall forårsaket av blinkende lys	1	C	A	A	D	C1	Spør deltagere om de har epilepsi

NTNU	Risikovurdering		Utarbeidet av	Nummer	Dato
			HMS-avd.	HMSRV/2601	22.03.2011
HMS			Godkjent av	Erstatter	
			Rektor		01.12.2006
					

4	Arbeid på PC	Musearm	3	A	A	A	A	A3	Tøye etter lange programmerings- og skrivekøtter. Veksle arbeidsform gjennom dagen
---	--------------	---------	---	---	---	---	---	----	--

Sannsynlighet vurderes etter følgende kriterier:

Svært liten 1	Liten 2	Middels 3	Stor 4	Svært stor 5
1 gang pr 50 år eller sjeldnere	1 gang pr 10 år eller sjeldnere	1 gang pr år eller sjeldnere	1 gang pr måned eller sjeldnere	Skjer ukentlig

Konsekvens vurderes etter følgende kriterier:



Gradering	Menneske	Ytre miljø Vann, jord og luft	Øk/materiell	Omdømme
E Svært Alvorlig	Død	Svært langvarig og ikke reversibel skade	Drifts- eller aktivitetssjans > 1 år.	Troverdighet og respekt betydelig og varig svekket
D Alvorlig	Alvorlig personskade. Mulig utørhet.	Langvarig skade. Lang resitussjonstid	Driftsstatus > ½ år Aktivitetssjans i opp til 1 år	Troverdighet og respekt betydelig svekket
C Moderat	Alvorlig personskade.	Mindre skade og lang resitussjonstid	Drifts- eller aktivitetssjans < 1 mnd	Troverdighet og respekt svekket
B Liten	Skade som krever medisinsk behandling	Mindre skade og kort resitussjonstid	Drifts- eller aktivitetssjans < 1uke	Negativ påvirkning på troverdighet og respekt
A Svært liten	Skade som krever førstehjelp	Ubetydelig skade og kort resitussjonstid	Drifts- eller aktivitetssjans < 1dag	Liten påvirkning på troverdighet og respekt

Risikoverdi = Sannsynlighet x Konsekvens

Beregn risikoverdi for Menneske. Enheten vurderer selv om de i tillegg vil beregne risikoverdi for Ytre miljø, Økonomi/materiell og Omdømme. I så fall beregnes disse hver for seg.

Til kolonnen "Kommentarer/status, forslag til forebyggende og korrigerende tiltak":

Tiltak kan påvirke både sannsynlighet og konsekvens. Prioriter tiltak som kan forhindre at hendelsen inntreffer, dvs. sannsynlighetsreduserende tiltak foran skjernet beredskap, dvs. konsekvensreduserende tiltak.

NTNU	Risikomatrise			Utarbeidet av	Nummer	Dato	
				HMS-avd.	HMSRV2604	08.03.2010	
HMS/IKS				godkjent av		Estatler	
				Rektor		09.02.2010	

MATRISSE FOR RISIKOVURDERINGER ved NTNU

KONSEKVENNS						
Svært alvorlig	E1	E2	E3	E4	E5	
Alvorlig	D1	D2	D3	D4	D5	
Moderat	C1	C2	C3	C4	C5	
Liten	B1	B2	B3	B4	B5	
Svært liten	A1	A2	A3	A4	A5	
	Svært liten	Liten	Middels	Stor	Svært stor	
SANNSYNLIGHET						

Prinsipp over akseptkriterium. Forklaring av fargene som er brukt i risikomatrisen.

Farge	Beskrivelse
Rød	Uakseptabel risiko. Tiltak skal gjennomføres for å redusere risikoen.
Gul	Vurderingsområde. Tiltak skal vurderes.
Grønn	Akseptabel risiko. Tiltak kan vurderes ut fra andre hensyn.