

Kjetil Trovik Midthun

# Optimization models for liberalized natural gas markets

Thesis for the degree of philosophiae doctor

Trondheim, October 2007

Norwegian University of  
Science and Technology  
Faculty of Social Science and Technology Management  
Department of Industrial Economics and Technology  
Management

NTNU  
Norwegian University of Science and Technology

Thesis for the degree of philosophiae doctor

Faculty of Social Science and Technology Management  
Department of Industrial Economics and Technology Management

©Kjetil Trovik Midthun

ISBN 978-82-471-4512-8 (printed ver.)  
ISBN 978-82-471-4526-5 (electronic ver.)  
ISSN 1503-8181

Theses at NTNU, 2007:205

Printed by Tapir Uttrykk

# Acknowledgements

This thesis is the result of my work for the degree of Philosophiae Doctor at the Department of industrial economics and technology management, at the Norwegian University of Science and Technology (NTNU).

First of all I would like to thank my supervisor Asgeir Tomasgard. His continued support and guidance has been very important for my work. Some of the best and most inspiring moments in the work with this thesis were our discussions. My co-supervisor, Mette Bjørndal, has also been important in the work with this thesis. I really appreciate the time we spent working together.

From November 2005 to March 2006 I visited Professor Yves Smeers at the Center for Operations Research and Econometrics (CORE), in Louvain-la-Neuve (Belgium). Working with Professor Yves Smeers was interesting and inspiring. In addition, the stay allowed me to meet many nice people at CORE and introduced me to Belgian culture.

I also want to thank good colleagues at the Department, especially Peter Schütz who has faced many of the same problems and challenges as I have since we started on our PhDs back in autumn 2002. I am also grateful to Matthias Nowak for always taking the time to answer my questions.

My friends in Trondheim have been very important for me in this period. I want to thank Håvard Berland, Hugo Hammer, Geir Solgaard and Steinar Kragset for many good memories.

I am grateful to my family at home for always providing support and encouragement. I want to thank Astrid for putting things in perspective when my frustration with the work was at a maximum. Finally I want to thank Katrine for putting up with me through a lot of hectic periods and for cheering me up when I am down. I look forward to spending more time with you all in the time to come.

Kjetil Trovik Midthun

Trondheim, August 2007



# Contents

<b>1</b>	<b>Introduction</b>	<b>1</b>
1.1	The natural gas value chain . . . . .	2
1.2	Operations research modeling framework . . . . .	7
1.3	Existing literature and research contribution . . . . .	12
1.4	Papers . . . . .	17
	Bibliography . . . . .	19
<b>2</b>	<b>Optimization Models for the Natural Gas Value Chain</b>	<b>29</b>
2.1	Introduction . . . . .	29
2.2	The Natural Gas Value Chain . . . . .	30
2.3	A Natural Gas Transportation Model . . . . .	34
2.4	Management of Natural Gas Storages . . . . .	48
2.5	Value Chain Optimization and Portfolio Management . . . . .	52
2.6	The Expected Gas Value Function ( <i>EGV</i> ) . . . . .	61
2.7	Conclusions . . . . .	65
2.A	Notation and Definitions . . . . .	66
	Bibliography . . . . .	69
<b>3</b>	<b>Modeling optimal economic dispatch and flow externalities</b>	<b>75</b>
3.1	Introduction . . . . .	75
3.2	Natural gas flows . . . . .	77
3.3	Max flow and network externalities - two numerical examples . . . . .	87
3.4	Optimal dispatch with economic objective functions . . . . .	93
3.5	Optimal economic dispatch - two numerical examples . . . . .	97
3.6	Conclusions . . . . .	104
3.A	Linearization of the Weymouth equation . . . . .	106
3.B	Unconstrained equilibrium . . . . .	107
	Bibliography . . . . .	108
<b>4</b>	<b>An operational portfolio optimization model for a natural gas producer</b>	<b>113</b>
4.1	Introduction . . . . .	113
4.2	Modeling natural gas networks . . . . .	115
4.3	The portfolio optimization model . . . . .	122
4.4	Test case from the Norwegian continental shelf . . . . .	128

4.5	Computational results and discussion . . . . .	134
4.6	Conclusions . . . . .	139
	Bibliography . . . . .	140
<b>5</b>	<b>Capacity booking in a Transportation Network with stochastic demand and a secondary market for Transportation Capacity</b>	<b>147</b>
5.1	Introduction . . . . .	147
5.2	Problem description and assumptions . . . . .	149
5.3	Model . . . . .	154
5.4	Model properties . . . . .	162
5.5	Numerical examples . . . . .	165
5.6	Conclusions . . . . .	172
5.A	The equilibrium conditions . . . . .	174
	Bibliography . . . . .	183

# Chapter 1

## Introduction

This thesis presents different optimization models for the natural gas value chain. It focuses on the new challenges faced by the participants in the value chain for Norwegian gas after the liberalization of the European gas markets. Most of the models have a producer perspective and are designed to help analyze the value chain for natural gas and give decision support for the gas producers. The modelling framework in this thesis consists of linear programming, mixed integer programming, quadratic programming, stochastic programming and mixed complementarity problems. The thesis consists of this introductory summary and four papers. Some of the work in this thesis has been sponsored by the VENOGA and the RAMONA project. VENOGA is a project involving Statoil, the Research Council of Norway, NTNU and SINTEF. The goal of the project is to build decision support models and competence for efficient operation and coordination in value chains where Norwegian gas is central. The RAMONA project involves the University in Stavanger, the University in Bergen, NTNU, SINTEF, Statoil, Gassco and CognIT. The intention with the project is to develop methods to optimize regularity and security of supply for the Norwegian gas production- and transportation system.

Part 1 of the thesis consists five sections. In this first section a short introduction to the thesis is given, in section 2 the background for the thesis as well as a presentation of the natural gas value chain is presented. Section 3 gives an introduction to the model types I have worked within. In section 4, relevant literature is presented and I indicate where the papers in this thesis extend the existing literature. Lastly, in section 5, a summary of the papers included in this thesis is given.

Part 2 consists of the four papers included in this thesis. The first paper, ‘Optimization Models for the Natural Gas Value Chain’, gives a thorough introduction to the natural gas value chain, and modeling techniques for the different parts of the value chain. The paper is meant as a tutorial on modeling natural gas value chains.

In the second paper, ‘Modeling optimal economic dispatch and flow externalities in natural gas networks’, a model for economic analysis in natural gas transportation networks is presented. The model includes a presentation of the

pressure constraints and system effects in natural gas networks; in addition it uses economic objective functions (such as maximization of social surplus).

The third paper is ‘An operational portfolio optimization model for a natural gas producer’. The model presented here has a system perspective, where we assume that all decisions in the value chain is made by a central planner. The value of actively using the pipelines in the network as storage (line-pack) to maximize profits is examined using a stochastic model and real market data from three European market hubs.

The last paper, ‘Capacity booking in a Transportation Network with stochastic demand and a secondary market for Transportation Capacity’, provides an equilibrium model of the booking system in the North Sea. The effects of different objective functions for the network operator are discussed. In addition, the importance of system effects and stochasticity is analyzed.

## **1.1 The natural gas value chain**

In this section I describe the background for the papers in this thesis and give an introduction to the natural gas value chain. The focus will be on the North Sea, and especially on the Norwegian interests.

In 2006, the petroleum industry accounted for approximately 36 % of the total income for the Norwegian economy. Natural gas is increasing in importance in the petroleum industry, and the production of natural gas is expected to reach 42% of total petroleum production in Norway by 2010. In a European context, the Norwegian production of natural gas is significant and accounts for approximately 15% of the natural gas consumption. Most of the gas is transported to Germany and France, where Norwegian gas accounts for approximately 30% of the total consumption.

### **The liberalization process**

An important part of the background for this thesis is the liberalization process in the natural gas industry in Europe. The process has been ongoing for more than twenty years, starting in Great Britain. Great Britain is also today the country that is most advanced in the liberalization process, measured by market opening and liquidity in the short-term markets. For a discussion of the liberalization process in Great Britain, see Roeber (1996) and Weir (1999). Also in other landing points for natural gas in Europe, such as Zeebrugge and the TTF, short-term markets have emerged. Financial markets with natural gas as the underlying commodity is developing in these market hubs. This indicates a growing trust in the liquidity of the spot markets. Neumann et al. (2006) gives an example of econometric analysis of the convergence of European spot market



prices for natural gas. The paper shows that the Interconnector (a pipeline which connects the market hubs in NBP and Zeebrugge) has led to almost perfect price convergence between the NBP (National Balancing Point in Great-Britain) and Zeebrugge in the time period considered in the paper.

The liberalization process has to a large degree been driven by the European Union. This is in contrast to the process in the US and UK which were mainly market driven. The European Union has decided on two gas directives that specifies the development of one internal European market (European Union 1998, 2003, European Commission & Transport 2002). The most important part of the directives is the decision to open transportation infrastructure for third party access.

### **Implications for the value chain in the North Sea**

The supply side in the North Sea is dominated by large companies. Before the liberalization process, coordination of production and transportation on the Norwegian continental shelf was accomplished through inter company groups like the Gas Supply Committee (Forsyningsutvalget, FU) and the Gas Negotiating Committee (Gassforhandlingsutvalget, GFU). In 2001 the GFU was abandoned and replaced by individual company sales. The large production companies also own the transportation infrastructure. After the liberalization process, the ownership of the infrastructure was given to a newly formed company: Gassled (owned by the original owners of the infrastructure). Gassled has ownership of all infrastructure open for third party access. New infrastructure facilities will be incorporated in Gassled when used by a third party.

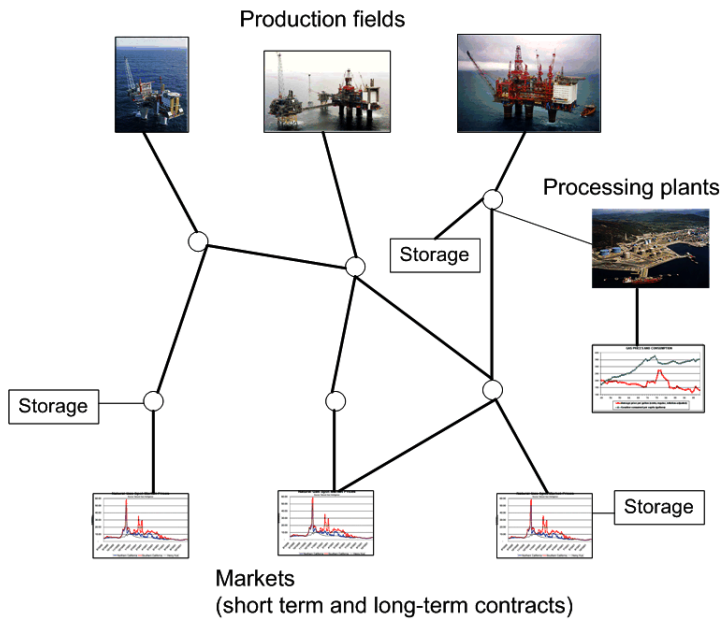
The routing in the network in the North Sea is the responsibility of Gassco. Gassco is an independent company responsible for ensuring nondiscriminatory access to the infrastructure owned by Gassled. The tariffs in the network are regulated by the ministry of petroleum and energy. The intention is to ensure that the profits are generated in the production fields and not in the transportation network. The access to the network is decided by allocation rules (Ability to Use and Capacity Allocation Key). For more information on the tariff system, see Gassco (2006). For details on the liberalization process in Norway, see Austvik (2003) and Dahl (2001).

### **Elements in the natural gas value chain**

Natural gas is formed naturally from organic material: plant and animal remains. Subjected to high pressure and temperature over millions of years, the organic material changed into coal, oil and natural gas. Natural gas is a mixture of hydrocarbon and non-hydrocarbon gases (such as helium, hydrogen sulfide, and

nitrogen). The gases are found in porous geological formations (reservoirs) beneath the earth's surface. In these reservoirs, the gas can be in gaseous phase or in solution with crude oil. Unlike other fossil energy sources, the natural gas is a relatively clean fuel, meaning that it emits lower levels of harmful byproducts when burnt than for instance oil and coal. Useful sites for information on natural gas are NGSA (2007), Gassco (2006) and EIA (2006).

A simplified picture of the offshore natural gas value-chain in the North Sea is shown in Figure 1.1. The gas is transported from the production fields to processing plants, or directly to the market hubs in Europe. There are storage possibilities along the transportation route. In addition, the transportation network itself can be considered as a storage facility since there are large volumes of gas contained in the pipelines at all times. In the following I will go shortly through some of the important characteristics of the natural gas value chain.



**Figure 1.1:** Illustration of the natural gas value chain.

## Exploration

Before any gas is produced, the gas must be located and wells must be drilled. A common method for exploration on the North-Continental shelf is seismology.

The methods have been developed from simple two-dimensional seismology in the early 1970s to the latest technology where four dimensions are being recorded (the fourth being shear waves). In addition to seismology, methods such as magnetometers and gravimeters can also be used. The magnetometers measures small differences in the Earth's magnetic field, while the gravimeters measure the Earth's gravitational field. In addition, mathematical models are used to predict the underground geological structures and conditions. The models give a hypothetical picture of the subsurface.

The procedures developed so far can only indicate where the gas deposits are located. Exploratory wells must be drilled in order to prove the existence and actual characteristics of the deposits. The cost of drilling such exploratory wells is high, and the location of these wells is important for further development of the fields. After a well is drilled, new information is available to the developers. The new information will influence the optimal total allocation of wells on the field.

### **Production and processing**

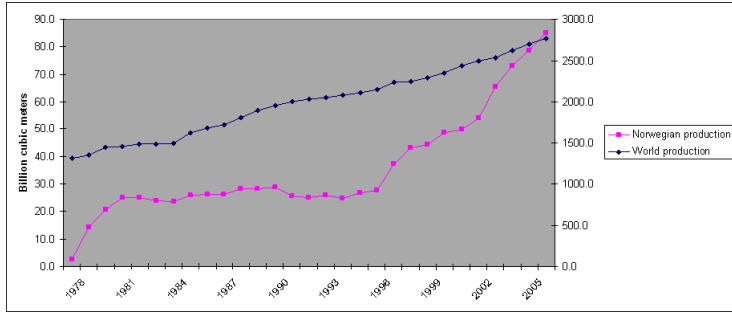
The gas is produced from the reservoirs. The driving forces are pressure from the expanding gas as well as water which causes the gas to flow into the well. The gas production depends on the pressure in the reservoirs. High pressure in the reservoir gives a high production rate. In order to increase the pressure in the reservoir, and thus increase production capacity, compressors are sometimes used.

The natural gas sold to Europe consists mainly of methane (dry gas). The gas produced at the fields can however contain other components with market value, such as associated hydrocarbons (for instance ethane, propane and butane). Gas containing both dry gas and associated hydrocarbons is called rich gas. The rich gas is transported to processing plants where the dry gas and wet gas (the associated hydrocarbons) are separated. The wet gas is then heated in order to separate the different components, which in turn is sold in component markets. Modeling of processing plants is not within the scope of this thesis, but the interested reader can consult Bullin (1999) for examples.

Figure 1.2 illustrates the production of gas in Norway and in the world in total. As we can see from this figure, the Norwegian production has increased drastically the last ten years.

### **Transportation**

In the North Sea, the gas is transported from the production fields offshore to processing plants on the Norwegian mainland or to market hubs on the European mainland and in Britain through long, sub sea pipelines operated at high pressure



**Figure 1.2:** The development of gas production in Norway and in the world in total.

levels. The gas molecules flow in the pipeline from high pressure points to low pressure points. At the production fields, pressure is increased with compressors in order to create a pressure difference that is sufficient for the gas to flow to the landing points. With the completion of Langeled (pipeline), the network consists of 7800 km of pipelines. For details on the infrastructure and topology in the North Sea, see OED (2006).

Natural gas flow is a multi-commodity flow, where the different components have different market value. The components give the gas flow different properties, and factors such as calorific value and corrosion of pipelines depend on the mixture of components in the flow.

### Storage

The demand for natural gas shows strong seasonal patterns and large short-term volatility (day-to-day variation in the prices). Both these factors give a large value to optimal storage utilization. Since the sale of natural gas is limited both by production capacity in the fields and the transportation network connecting the fields to the market nodes, there is a large value in storing gas close to the market nodes in the summer (when demand is low) in order to sell more gas in winter (when demand is high). In the same manner, gas can be injected to the storages during days with low price / low demand and extracted from the storage when the price is favorable. There are many different forms of storages that are used for storing natural gas: abandoned oil- and gas fields, aquifers, LNG-storages and salt caverns. The storages are different with respect to capacity, injection- and extraction capabilities and cost of operating. For more information on storages, see EIA (2002). In addition, the pipeline network can also be used as storage (line-pack). This is due to the fact that there are large volumes of natural gas

contained in the pipelines. This volume is needed for gas to flow in the pipelines. By injecting more gas into the network than is extracted in a given time period, the line-pack is increased. If however more gas is extracted than injected, the line-pack is decreased.

### **Markets**

Traditionally, the gas from the North Sea has been sold in long-term take-or-pay contracts (TOP). In the TOP-contracts, the price is determined based on a formula which main components are the prices of competing fuels (for instance oil). A yearly volume is decided, and then the buyers have flexibility with respect to nomination on shorter time-periods (within certain limits). If the total volume during a year is lower than the agreed upon volume, the buyers still pays for the agreed volume. Originally, these contracts were established for field and market combinations. This means that it was determined which field should deliver in which contract. After the liberalization process in Norway, this has changed, and the companies are now free to deliver the contracted volumes from the field of their choice.

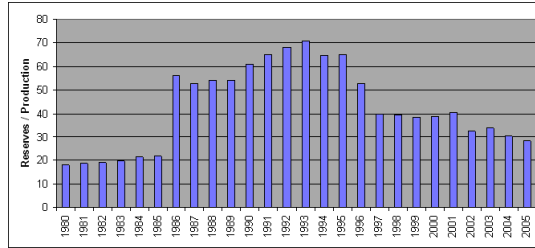
In the market hubs, short-term markets have emerged. The price in the short-term markets is volatile. The markets have so far had low liquidity, but the situation is improving. The increasing liquidity in the markets is indicated by the development of forward and future contracts with natural gas as the underlying commodity. For a discussion of the development of the spot market for natural gas in the UK, see Roeber (1996). For a discussion of price models for commodities, see for instance Schwarz (1997).

### **Remaining reserves**

No one knows exactly how much gas is left in the ground for us to use, but we do have some estimates. The volume of proved reserves has increased over the years. Today the reserves are sufficient for approximately 65 years (given that today's production level is kept constant). If we look at Norway, the reserves to production ratio is approximately 30 (see Figure 1.3). All data used in this section is provided by BP (2006).

## **1.2 Operations research modeling framework**

This thesis is within the field of operations research (OR). Operations research can be defined as an interdisciplinary science which uses quantitative methods to support decision making. In this thesis the main focus is on mathematical programming, which can be defined as the study of problems where one seeks to



**Figure 1.3:** Reserves to production ratio for Norway.

maximize or minimize a real function by choosing the values of real or integer variables from an allowed set.

In the following I will give a short introduction to the model types that I have worked with in this thesis. The overview is meant for the non-expert reader and it does not give a comprehensive introduction to the model types. References to literature where more information can be found is given for each model type.

An introduction to the field of operations research can be found in textbooks such as, for instance Hillier & Lieberman (2001). Webpages, such as the homepage of the Institute for Operations Research and the Management Sciences (INFORMS 2007), provides information and overviews of available resources in the field of operations research.

## Linear programming (LP)

In linear programming, a linear objective function is optimized (maximized or minimized) over a convex polyhedron specified by linear and non-negativity constraints. George B. Dantzig is often considered as the founder of LP (Dantzig 1949, Wood & Dantzig 1949). Other important contributors are, for instance, John von Neumann and Leonid Kantorovich. For a nice overview of the history of the development of Linear Programming, see Dantzig (1991).

The general LP problem can be formulated in the following way:

$$\max c^T x \quad (1.1)$$

$$\text{s.t. } Ax \leq b \quad (1.2)$$

$$x \geq 0 \quad (1.3)$$

The decision variables in the problem is given by  $x$ .  $c^T$ ,  $A$  and  $b$  are parameters. Equation (1.1) is the objective function, while Equation (1.2) gives the constraint on the decision variables  $x$ . Equation (1.3) is the non-negativity constraints on

$x$ . Equations (1.2) and (1.3) define the feasible set for  $x$ . The  $x$  variables could also have been unrestricted in sign.

## Mixed integer programming (MIP)

When some of the variables in the optimization problem are required to take an integer value, the model type is called Mixed Integer Programming. If all variables in the problem are restricted to be integer, the model type is called Integer Programming (IP). IP and MIP problems are by definition non-convex problems. The simplex method can not be used directly on this problem class. A nice introduction to integer programming is given in Wolsey (1998).

An example of a MIP problem is given by:

$$\max c^T x + d^T y \tag{1.4}$$

$$\text{s.t. } Ax + Dy \leq b \tag{1.5}$$

$$x \geq 0 \tag{1.6}$$

$$y \text{ integer} \tag{1.7}$$

The decision variables are given as  $x$  and  $y$ , where  $y$  is required to be integer.  $c^T$ ,  $d^T$ ,  $A$ ,  $D$  and  $b$  are parameters. The objective function is given by Equation (1.4). Equation (1.5) is a constraint in the problem, and Equations (1.6) and (1.7) gives, respectively, the non-negativity constraint on  $x$  and the integer constraint for  $y$ . Equations (1.5)-(1.7) define the feasible set for  $x$  and  $y$ .

## Quadratic programming (QP)

Quadratic programming is a special case of non-linear programming, where the objective function is quadratic while the constraint set consists of linear equations. Since the quadratic programs have much in common with the LP programs, powerful dual and complementarity slackness properties allow specialized algorithms for many cases. Examples of textbooks with more information on QP are Bazaraa et al. (1993) and Hillier & Lieberman (2001).

An example of a QP problem is given by:

$$\max c^T x + x^T Q x \tag{1.8}$$

$$\text{s.t. } Ax \leq b \tag{1.9}$$

$$x \geq 0 \tag{1.10}$$

The decision variables are given by  $x$ , while  $c^T$ ,  $Q$ ,  $A$  and  $b$  are parameters. Equation (1.8) gives the objective function for the problem, while Equations (1.9)

and (1.10) define the feasible set for  $x$ . The second paper in this thesis use quadratic programming to represent economic objective functions (social surplus, producer surplus and consumer surplus) in situations where there are supply and demand curves present in, respectively, production nodes and market nodes.

## Stochastic programming (SP)

In many situations uncertainty is an important characteristic of the problem we try to model. Examples are uncertainty in prices and demand for a commodity. Stochastic programming is a problem class that allows the modeler to take the uncertainty into account when building the model. This way, the model will put a value on flexibility in decisions. When everything is known for certain, flexibility is of no value (you do not have to change decisions since you know what will happen).

The first papers on SP were Dantzig (1955) and Beale (1955). Examples of textbooks that give a thorough introduction to the field of stochastic programming are Kall & Wallace (1994) and Birge & Loveaux (1997). In addition Higele (2005) gives a nice tutorial on the field. The home page of the Stochastic Programming Community (COSP 2007) has a lot of resources available within the field of SP.

An often used approach to represent the uncertainty in the model is a scenario tree, see for example (Birge & Loveaux 1997). In the scenario tree, a discrete representation of the uncertainty is created. There are many different ways of obtaining this representation, for a nice discussion, see Kaut & Wallace (2007). Figure 1.4 shows an example of a scenario tree. In each leaf node in the tree there is a realization of the stochastic parameter (for instance price). In addition, there is a set of decision variables in each node of the scenario tree. The decisions in the root node are the same for all scenarios, and are called the first-stage decisions. In the second stage, the decisions will depend on the realization of the stochastic parameters.

An example of a SP problem is given by:

$$\max c^T x + \sum_{s \in \mathcal{S}} p_s d_s^T y_s \quad (1.11)$$

$$\text{s.t. } Ax = b \quad (1.12)$$

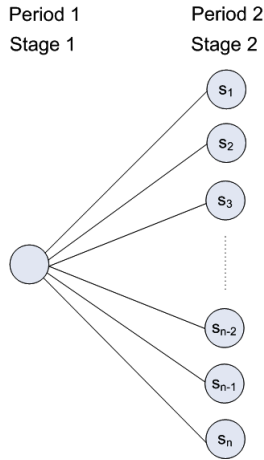
$$T_s x + W_s y_s = h_s, \quad s \in \mathcal{S} \quad (1.13)$$

$$x \geq 0 \quad (1.14)$$

$$y_s \geq 0, \quad s \in \mathcal{S} \quad (1.15)$$

The first stage decision variables are given by  $x$ . In each scenario  $s$  in the set





**Figure 1.4:** An example of a scenario tree.

of scenarios  $\mathcal{S}$  there is a decision variable  $y_s$ . The objective function, in Equation 1.11, gives the profit from the first stage decisions and the expected profits for the second stage decisions. The probability for each scenario is given by  $p_s$ . The feasible set for the problem is defined by Equations (1.12)-(1.15).

### Mixed complementarity problems (MCP)

Mixed complementarity problems refer to a wide range of problems where the defining equations consist of both complementarity conditions and equality constraints. For a nice introduction to complementarity problems, see Billups & Murty (2000) and Cottle et al. (1992). In the last paper in this thesis we present a linear mixed complementarity problem.

An example of a linear mixed complementarity problem is given by:

$$a + Au + Cv = 0 \tag{1.16}$$

$$b + Du + Bv \geq 0 \tag{1.17}$$

$$v \geq 0 \tag{1.18}$$

$$v^T (b + Du + Bv) = 0. \tag{1.19}$$

The decision variables are given by  $u$  and  $v$ .  $A$ ,  $C$ ,  $b$ ,  $D$  and  $B$  are parameters. Equation (1.19) is the complementarity condition in this problem. The product

of variable  $v$  and the left hand side in constraint (1.17) must be zero. Equations (1.17), (1.18) and (1.19) gives a linear complementarity problem (LCP). By including variable  $u$  and constraint (1.16) we get a mixed complementarity problem.

The KKT-conditions of an optimization problem can be formulated as a mixed complementarity problem. By aggregating the KKT-conditions of several players (several optimization problems) in a multiplayer game, equilibrium problems can be solved. The MCPs can be used to find Nash equilibria (Nash 1950), and Generalized Nash Equilibria (Debreu 1952, Arrow & Debreu 1954). In a Nash Equilibrium no player has incentive to deviate from his decisions given that the other players do not deviate. Generalized Nash Equilibria is found in the situation where the players can influence the feasible region of each others' optimization problems.

### 1.3 Existing literature and research contribution

In the following I will give a short introduction to the literature on different aspects of the natural gas, and in addition indicate where this thesis extends the existing literature.

The petroleum industry has been a pioneer in the application of operations research, and the literature is therefore extensive. In Bodington & Baker (1990), an interesting overview of the history of mathematical programming in the petroleum industry is given.

#### Investment models

In this model class, the goal is to give decision support for strategic decisions such as field investments and sequencing of investments. There are a large number of publications within this field. This is not surprising given the large risks and costs associated with offshore investments.

There exist a number of deterministic investment models. Sullivan (1988) presents some applications of Mathematical Programming methods to investment problems in the petroleum industry. A new MIP model with a detailed description of reservoir production is also presented in the paper. In Haugland et al. (1988) existing models for early evaluations of petroleum fields are presented. The paper also presents a MIP model which proposes platform capacity, where and when wells should be drilled and production from the wells. Nygreen et al. (1998) presents a MIP model used by The Norwegian Petroleum Directorate. The model is a multiperiod model and is used for investment planning for fields in the North Sea which contain a mixture of oil and gas. In van den Heever & Grossmann (2001) a model for design and planning of offshore field

infrastructures is presented. The model is a multiperiod mixed-integer nonlinear programming model and incorporates complex fiscal rules, such as tariff, tax and royalty calculations. The net present value of projects is discussed in light of the fiscal rules.

There are also some models which incorporate uncertainty. Jørnsten (1992) presents an integer model for sequencing offshore oil and gas fields, where the objective is to maximize total economic benefit. In addition to the deterministic model, a stochastic version with uncertainty in future demand for natural gas is presented. In Haugen (1996) a stochastic dynamic programming model is constructed to analyze a supplier's problem of scheduling fields and pipelines in order to be able to meet contractual agreements. The uncertainty in the model is in the resources (production profiles). In Jonsbraten (1998) a stochastic MIP model for optimal development of an oil field is presented. The objective of the model is to maximize the expected net present value of the oil field given uncertain future oil prices. Goel & Grossmann (2004) presents a stochastic MIP model for planning of offshore gas field developments. The expected net present value is maximized under uncertainty in reserves.

## Value chain models

The upstream value chain of natural gas consists of several components, such as production, transportation, processing, storage and markets. Because of the special properties of the transportation network a value chain approach to optimizing the system is important. In the value chain approach, the complete network is considered and optimized simultaneously. The value chain approach has become even more valuable after the liberalization process, which meant an increase in flexibility for the participants in the value chain.

In Ulstein et al. (2007) planning of offshore petroleum production is studied on a tactical level. The model has a value chain approach where production plans, network routing, processing of natural gas and sales in the markets is considered. In addition, multi-commodity flows and quality restrictions in the markets are considered. The pressure constraints in the network is however not included in the model. The non-linear splitting for chemical processing is linearized with binary variables. The resulting model is mixed integer programming model.

Selot et al. (2007) presents an operational model for production and routing planning in the natural gas value chain. The model combines a detailed infrastructure model with a complex contractual model. There is no market for natural gas included in the model. The infrastructure model includes non-linear equations for relating pressure and flow in wells and pipelines, multi-commodity flows and contractual agreements in the market nodes (delivery pressure and quality of the gas). The contractual model is based on a set of logical conditions for produc-

tion sharing and customer requirements. The combined model is a mixed integer nonlinear programming model (MINLP). In addition, the model is non-convex due to the pressure-flow relationship and the modeling of multi-commodity flows.

In the first paper in this thesis, we present a tutorial for modeling of the natural gas value chain. This is the first publication (to our knowledge) which presents a portfolio optimization model with markets, contracts, production planning, multi-commodity flow and handling of the pressure constraints in the transportation network. The framework for analysis presented in this model is primarily aimed at a tactical level. In the third paper in this thesis, we present an operational stochastic model for portfolio optimization. In this paper we include the storage in the pipelines in the transportation network (line-pack) in the analysis. By using real market data from three European hubs, we give an estimate of the value of actively using the line-pack to maximize profits for the value-chain.

## Transportation models

The transportation of natural gas is one of the key elements when studying the natural gas industry. Because of the interdependence between flows in pipelines, it is important to find a tradeoff between accurately describing the properties of the transportation network, and being able to solve the model. A simplified representation leads to an inaccurate model of the transportation (and may lead to wrong conclusions), while a too detailed presentation makes the model non-linear and non-convex. In the following some examples of steady-state models, as well as more technical models and simplified economical models are given.

De Wolf & Smeers (2000) presents a model for optimizing gas flow through a network, with cost minimization. The flow in the network is steady-state, and the resulting problem is solved by an extension to the simplex algorithm. Also in O'Neill et al. (1979) a steady-state representation of the gas flow is used in a model for allocation of natural gas. Westphalen (2004) gives a nice presentation of stochastic optimization in gas transportation. The model presented in Selot et al. (2007) provides an accurate description of the steady-state flow using a non-convex MINLP model. In the first paper in this thesis we present a linearization of the Weymouth equation which enables analysis of large networks and stochastic problems.

There are a large number of publications with a technical approach to gas transportation. The models are detailed and accurate in their description of the physics of gas transportation, such as transient flow and interaction with compressors. A discussion of transient flows is given in Kelling et al. (2000), while the homepage of the Pipeline Simulation Interest Group (2007) gives a comprehensive overview on modeling, simulation and optimization of natural gas flows. In Ehrhardt & Steinbach (2005) a model for operational planning in natural

gas networks is presented. A transient flow model is used to control the network load distribution for the next 24 to 48 hours. Martin et al. (2006) presents a model to optimize flow in a network, and minimize the costs of the compressors in the network. The model gives a detailed representation of the physical properties of natural gas transportation, and offers linearization techniques for the nonlinearities in the model. Nowak & Westphalen (2003) presents a linear model for transient flow modeling.

There also exist some economical models with a simplified representation of the transportation networks. In these models, the capacities in the pipelines is normally represented with a fixed, static capacity limit. Examples of such models are Cremer & Laffont (2002) and Cremer et al. (2003). With the simplified representation of the transportation network, the system effects of natural gas transportation are neglected.

In the second paper in this thesis, we show that it is difficult, if not impossible, to determine appropriate static capacities in a natural gas network. We discuss the system effects in natural gas networks and provide a framework for economic analysis in natural gas networks. The paper uses the linearization of the Weymouth equation presented in paper one, and in addition it uses economic objective functions such as maximization of social surplus. This is the first example of economic analysis in a gas transportation network where the flows are determined based on pressure constraints. The discussion of system effects is similar to the discussion of externalities in the electricity networks. For a nice discussion of externalities in electricity networks, see Wu et al. (1996).

## Equilibrium models

Equilibrium models are used to study situations where more than one player acts strategically. The models are formulated as complementarity problems. A nice overview of complementarity problems in natural gas markets is given in Gabriel & Smeers (2005). The paper both gives a survey of some of the existing models, as well as develops relevant models for the restructured natural gas markets.

In Wolf & Smeers (1997) a stochastic version of the Stackelberg-Nash-Cournot model is presented. A market leader is deciding on his production level under uncertainty in demand, the followers then reacts to the production level after the uncertainty is resolved. The model is used on the European natural gas market. In Boots et al. (2004) the downstream market for natural gas in Europe is studied in a successive oligopoly approach. The players in the network include upstream producers and downstream traders. A mixed nonlinear complementarity problem (NCP) to study natural gas markets is presented in Gabriel et al. (2005). The model includes producers, storage reservoir operators, peak gas operators, pipeline operators and consumers. The KKT conditions are used to formulate the

NCP model. Zhuang & Gabriel (2006) presents a stochastic equilibrium model for deregulated natural gas markets. The first stage decisions in the MCP model are commitments in long-term contracts, while the second-stage decisions are spot market activities.

In the last paper in this thesis, we examine the booking procedure in the North Sea as a stochastic mixed complementarity problem. We formulate the problem as a Generalized Nash game and we then use theory from variational inequality to show existence of solution and to solve our problem. This is the first study of a booking system similar to the one implemented in the North Sea and, to our knowledge, also the first study of a booking system in a natural gas transportation network. It is also one of few examples of applications of stochastic mixed complementarity problems.

## 1.4 Papers

In the following I will give a short presentation of the papers, as well as a description of my contribution on each of them.

### **Paper 1: Optimization Models for the Natural Gas Value Chain**

The paper gives an overview of the modeling of a natural gas value chain, and is meant to be a tutorial on the subject. The importance of the value chain perspective as well as the portfolio perspective is discussed in the paper. The model includes spot markets, forward markets, long-term contracts, production plans, storage utilization, pressure constraints, compressors and multi-commodity flows. A linearization of the Weymouth equation, which allows studies of large scale networks, is presented. No numerical examples are presented in the paper. The content is based on the experience from work done in SINTEF and NTNU.

The modeling and analysis in the paper has been done on SINTEF and NTNU. My contribution is in structuring and writing large parts of the paper.

The paper is published in G. Hasle, K.-A. Lie, E. Quak (eds.): Geometric Modelling, Numerical Simulation and Optimization, Springer Verlag, 2007. Minor changes in the references have been made in the version included in this thesis.

Co-authors: Senior Researcher at SINTEF, Frode Rømo, Researcher at SINTEF, Marte Fodstad and my supervisor, Associate Professor Asgeir Tomasgard.

### **Paper 2: Modeling optimal economic dispatch and flow externalities in natural gas networks**

In this paper we combine the modeling framework developed in paper 1 with economic analysis. In the existing literature there are a number of economic models that disregard the system effects in natural gas transportation networks. Also, there exist a number of more technical models without economic analysis. In this paper we combine the two approaches, and provide a framework for economic analysis in natural gas transportation networks. We also examine the effects of ignoring the system effects when doing economic analysis.

I have done the implementation of the model. In addition, I have had an equal part in modeling, the analysis and in writing the paper.

The paper is submitted to an international journal.

Co-authors: co-supervisor, Associate Professor Mette Bjørndal and my supervisor, Associate Professor Asgeir Tomasgard.

### **Paper 3: An operational portfolio optimization model for a natural gas producer**

In this paper we present an operational optimization model for a natural gas producer. The model has a system perspective. We use the modeling framework presented in paper 1, and extends the model with pipeline storage (line-pack). To our knowledge, this is the first study of an operational stochastic portfolio optimization model for natural gas production and sales. We provide numerical examples based on real market data from three European hubs. Especially, we evaluate the commercial value of actively using the line-pack in the pipelines to maximize profits for the producers. We also examine the value of using a stochastic model compared to a deterministic model.

I have done the implementation of the model. In addition, I have had an equal part in modeling, the analysis and in writing the paper.

The paper is submitted to an international journal.

Co-authors: Post doc. Matthias P. Nowak and my supervisor, Associate Professor Asgeir Tomasgard.

### **Paper 4: Capacity booking in a Transportation Network with Stochastic Demand and a Secondary Market for Transportation Capacity**

In this paper we study allocation of transportation capacity in a system that resembles the one implemented in the North Sea. In papers 1, 2 and 3 we have used a system perspective on the value chain, but now we study the situation when more than one player is making decisions in the value chain. We look at different objective functions for the network operator, discuss the importance of modeling the pressure constraints in the network, and look at the effects stochasticity has on the solutions. The model is formulated as a Generalized Nash game. To our knowledge, this is the first time a booking system in a natural gas transportation network is studied using this approach.

I have done the implementation of the model. In addition, I have had an equal



part in modeling, the analysis and in writing the paper.

Co-authors: co-supervisor, Associate Professor Mette Bjørndal, Professor Yves Smeers and my supervisor, Associate Professor Asgeir Tomasgard.



## Bibliography

- Arrow, K. J. & Debreu, G. (1954), 'Existence of an equilibrium for a competitive economy', *Econometrica* **22**, 265–291.
- Austvik, O. G. (2003), *Norwegian Natural Gas. Liberalization of the European Gas Market*, Europa-programmet, Oslo, Norway.
- Bazaraa, M. S., Sherali, H. D. & Shetty, C. M. (1993), *Nonlinear Programming, Theory and Algorithms*, John Wiley & Sons, Inc., New York.
- Beale, E. M. L. (1955), 'On minimizing a convex function subject to linear inequalities', *Journal of the Royal Statistical Society, Series B* **17**, 173–184.
- Billups, S. C. & Murty, K. G. (2000), 'Complementarity problems', *Journal of Computational and Applied Mathematics* **124**, 303–318.
- Birge, J. R. & Loveaux, F. V. (1997), *Introduction to Stochastic Programming*, Springer.
- Bodington, C. E. & Baker, T. E. (1990), 'A history of mathematical programming in the petroleum industry', *Interfaces* **20**, 117–127.
- Boots, M. G., Rijkers, F. A. M. & Hobbs, B. F. (2004), 'Trading in the downstream european gas market: A successive oligopoly approach', *The Energy Journal* **25**.
- BP (2006), 'British petroleum homepage'. [www.bp.com](http://www.bp.com).  
**URL:** [www.bp.com](http://www.bp.com)
- Bullin, K. A. (1999), *Economic Optimization of Natural Gas Processing Plants Including Business Aspects*, PhD thesis, Texas A&M University.
- COSP (2007), 'Stochastic programming community', Home page.
- Cottle, R., Pang, J. & Stone, R. (1992), *The linear complementarity problem*, Academic press, Boston.
- Cremer, H., Gasmi, F. & Laffont, J. (2003), 'Access to pipelines in competitive gas markets', *Journal of Regulatory Economics* **24**(1), 5–33.

- Cremer, H. & Laffont, J. (2002), ‘Competition in gas markets’, *European Economic Review* **46**, 928–935.
- Dahl, H. J. (2001), Norwegian Natural Gas Transportation Systems. Operations in a Liberalized European Gas Market, PhD thesis, NTNU, Trondheim, Norway.
- Dantzig, G. B. (1949), ‘Programming of interdependent activities. II. mathematical model’, *Econometrica* **17**, 200–211.
- Dantzig, G. B. (1955), ‘Linear programming under uncertainty’, *Management Science* **1**, 197–206.
- Dantzig, G. B. (1991), Linear programming, in J. K. Lenstra, ed., ‘History of Mathematical Programming: A Collection of Personal Reminiscences’, North-Holland Publishing Co, Amsterdam, The Netherlands.
- De Wolf, D. & Smeers, Y. (2000), ‘The gas transmission problem solved by an extension of the simplex algorithm’, *Management Science* **46**(11), 1454–1465.
- Debreu, G. (1952), A social equilibrium existence theorem, in ‘Proceedings of the National Academy of Sciences’.
- Ehrhardt, K. & Steinbach, M. (2005), Nonlinear optimization in gas networks, in H. E. Bock, ed., ‘Modeling, Simulation and Optimization of Complex Processes’, Springer-Verlag, Berlin - Heidelberg - New York, pp. 139–148.
- EIA (2002), ‘The basics of underground natural gas storage’.  
[http://www.eia.doe.gov/pub/oil\\_gas/natural\\_gas/analysis\\_publications/storagebasics/storagebasics.pdf](http://www.eia.doe.gov/pub/oil_gas/natural_gas/analysis_publications/storagebasics/storagebasics.pdf).
- EIA (2006), ‘Energy information administration homepage’.  
**URL:** <http://www.eia.doe.gov/>
- European Commission, D.-G. f. E. & Transport (2002), ‘Opening up to choice: Launching the single european gas market’, Office for Official Publications of the European Communities.
- European Union (1998), ‘Directive 98/30/EC of the european parliament and of the council’.
- European Union (2003), ‘Directive 2003/55/EC of the european parliament and of the council’.
- Gabriel, S., Kiet, S. & Zhuang, J. (2005), ‘A mixed complementarity-based equilibrium model of natural gas markets’, *Operations Research* **53**(5), 799–818.

- Gabriel, S. & Smeers, Y. (2005), ‘Complementarity problems in restructured natural gas markets’, CORE Discussion Paper No. 2005/37.
- Gassco (2006), ‘Gassco homepage’. [www.gassco.no](http://www.gassco.no).  
**URL:** [www.gassco.no](http://www.gassco.no)
- Goel, V. & Grossmann, I. E. (2004), ‘A stochastic programming approach to planning of offshore gas field developments under uncertainty in reserves’, *Computers & Chemical Engineering* **28**, 1409–1429.
- Haugen, K. K. (1996), ‘A stochastic dynamic programming model for scheduling of offshore petroleum fields with resource uncertainty’, *European Journal of Operational Research* **88**, 88–100.
- Haugland, D., Åsa Hallefjord & Asheim, H. (1988), ‘Models for petroleum field exploitation’, *European Journal of Operational Research* **37**, 58–72.
- Higle, J. L. (2005), Stochastic programming: Optimizatin when uncertainty matters, in P. Gray, ed., ‘TutORials in Operations Research’, INFORMS.
- Hillier, F. S. & Lieberman, G. J. (2001), *Introduction to operations research*, McGraw-Hill Book Co, Singapore.
- INFORMS (2007), ‘Institute for operations research and the management sciences’, Home page. <http://www.informs.org/>.
- Jonsbraten, T. W. (1998), ‘Oil field optimization under price uncertainty’, *The Journal of the Operational Research Society* **49**, 811–818.
- Jørnsten, K. O. (1992), ‘Sequencing offshore oil and gas fields under uncertainty’, *European Journal of Operational Research* **58**, 191–201.
- Kall, P. & Wallace, S. W. (1994), *Stochastic Programming*, John Wiley & Sons, Chichester.
- Kaut, M. & Wallace, S. W. (2007), ‘Evaluation of scenario generation methods for stochastic programming’, *Pacific Journal of Optimization* **3**, 257–271.
- Kelling, C., Reith, K. & Sekirnjak, E. (2000), A practical approach to transient optimization for gas networks, Technical report, PSIG.
- Martin, A., Möller, M. & Moritz, S. (2006), ‘Mixed integer models for the stationary case of gas network optimization’, *Mathematical Programming* **105**(2-3), 563–582.
- Nash, J. (1950), Equilibrium points in n-person games, in ‘Proceedings of the national academy of sciences’.

- Neumann, A., Siliverstovs, B. & von Hirschhausen, C. (2006), ‘Convergence of european spot market prices for natural gas? a real-time analysis of market integration using the kalman filter’, *Applied Economics Letters* **13**, 727–732.
- NGSA (2007), ‘Natural gas supply association homepage’. [www.naturalgas.org](http://www.naturalgas.org).  
**URL:** [www.naturalgas.org](http://www.naturalgas.org)
- Nowak, M. & Westphalen, M. (2003), A linear model for transient gas flow, in ‘Proceedings of ECOS’, pp. 1751–1758. available as SINTEF-report STF 38S03601, Trondheim, Norway.
- Nygreen, B., Christiansen, M., Bjørkvoll, T., Haugen, K. & Kristiansen, Ø. (1998), ‘Modelling norwegian petroleum production and transportation’, *Annals of Operations Research* **82**, 251–267.
- OED (2006), ‘Fakta norsk petroleumsvirksomhet 2006’.
- O’Neill, P., Williard, M., Wilkins, B. & Pike, R. (1979), ‘A mathematical programming model for allocation of natural gas’, *Operations Research* **27**(5), 857–873.
- Pipeline Simulation Interest Group (2007), ‘PSIG homepage’.  
**URL:** [www.psig.org](http://www.psig.org)
- Roeber, J. (1996), ‘The development of a UK natural gas spot market’, *Energy Journal* **17**, 1–15.
- Schwarz, E. (1997), ‘The stochastic behavior of commodity prices: Implications for valuation and hedging’, *The Journal of Finance* **52**(3), 923 – 973.
- Selot, A., Kuok, L. K., Robinson, M., Mason, T. L. & Barton, P. I. (2007), A short term operational planning model for upstream natural gas production systems. to appear in AIChE Journal.
- Sullivan, J. (1988), ‘The application of mathematical programming methods to oil and gas field development planning’, *Mathematical Programming* **42**, 189–200.
- Ulstein, N., Nygreen, B. & Sagli, J. (2007), ‘Tactical planning of offshore petroleum production’, *European Journal of Operational Research* **176**, 550–564.
- van den Heever, S. A. & Grossmann, I. E. (2001), ‘A lagrangean decomposition heuristic for the design and planning of offshore hydrocarbon field infrastructures with complex economic objectives’, *Ind. Eng. Chem. Res* **40**, 2857–2875.

- Weir, C. (1999), 'Regulation and the development of competition in the U.K. gas supply industry', *Review of industrial organization* **15**, 135–147.
- Westphalen, M. (2004), Anwendungen der Stochastischen Optimierung im Stromhandel und Gastransport, PhD thesis, University Duisburg-Essen (Germany).
- Wolf, D. D. & Smeers, Y. (1997), 'A stochastic version of a stackelberg-nash-cournot equilibrium model', *Management Science* **43**(2).
- Wolsey, L. A. (1998), *Integer Programming*, John Wiley & Sons, Inc.
- Wood, M. K. & Dantzig, G. B. (1949), 'Programming of interdependent activities. I. general discussion', *Econometrica* **17**, 193–199.
- Wu, F., Varaiya, P., Spiller, P. & Oren, S. (1996), 'Folk theorems on transmission access: Proofs and counterexamples', *Journal of Regulatory Economics* **10**(1), 5–23.
- Zhuang, J. & Gabriel, S. (2006), A complementarity model for solving stochastic natural gas market equilibria. January 2006, Energy Economics, accepted.





# Paper I

Asgeir Tomasgard, Frode Rømo, Marte Fodstad and Kjetil Midthun:

## *Optimization Models for the Natural Gas Value Chain*

*Chapter in G. Hasle, K.-A. Lie, E. Quak (eds.): Geometric Modelling,  
Numerical Simulation and Optimization, Springer Verlag, 2007*



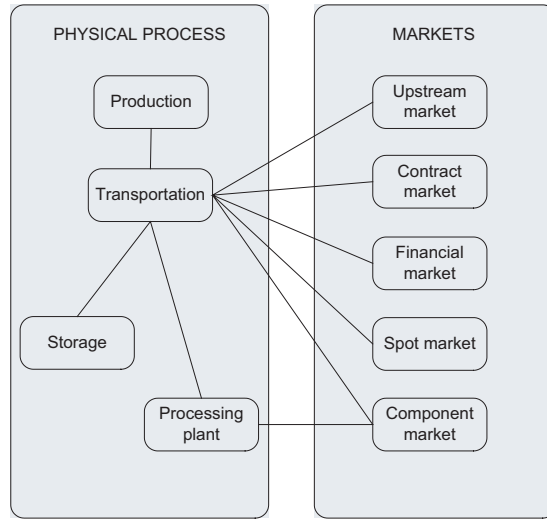
## Chapter 2

# Optimization Models for the Natural Gas Value Chain

### 2.1 Introduction

The models in this chapter are based on the authors experience from making decision support tools for the Norwegian gas industry. Our focus is on describing modeling techniques and important technological issues, rather than a very detailed representation needed for commercial models. We study the natural gas value chain seen from the point of view of an upstream company with a portfolio of production fields. Such a company should plan its operations considering long term contract obligations, the short term markets and transportation capacity booking. In particular we describe how the operations and planning are influenced by the existence of spot markets and forward markets. For the models to make sense it is also critical to include the technological characteristics of natural gas transportation and processing. We therefore give a set of models where the interplay between the technological characteristics of natural gas and the markets are highlighted. In these models the economical content and the understanding of gas markets is essential.

We structure the paper by gradually introducing the different levels of the supply chain. We start by describing the most important components of the natural gas value chain in Section 2. Then in Section 3 we focus on how to model natural gas transportation in a steady-state situation. This is the type of transportation models suitable for planning problems with time resolution weeks, months or years. In Section 4 we introduce gas storages and in Section 5 we describe a portfolio perspective and start investigating the integrated supply chain view. Here we introduce short term markets. In Section 6 we see how the spot-markets can be used to price natural gas storage capacity and indicate how to estimate the terminal value of natural gas still in storages or in reservoirs at the end of the planning horizon using the concept of an Expected Gas Value Function. An appendix describing all notation used in the paper is included at the end. All together these sections will give a supply chain optimization model with an integrated view of the value chain, from production, via transportation



**Figure 2.1:** Important objects in the natural gas value chain

and processing to contract management and gas sales.

## 2.2 The Natural Gas Value Chain

Here we give a brief description of the different elements of the natural gas value chain on the Norwegian continental shelf: production, transportation, processing, contract management and sales. The first action is to transport the natural gas from production fields to processing plants or transportation hubs where gas from different fields is mixed. Rich gas components are extracted and sold in separate markets. The remaining dry gas is transported to the import terminals in UK or on the European continent. In these hubs bilateral contracts and spot-trades are settled. Also upstream markets exist, where the gas is sold before it is transported to the import terminals. We focus on the value chain of a producing company, hence the issues of transmission and distribution to end customers are not considered.

In Figure 2.1 we show the main components of the natural gas export value chain. Before we go in detail on these we give a short summary of the main effects of liberalization and regulation in the European gas market.

## **Production**

Production of natural gas takes place in production fields. Often these fields have several owners, and each owner has production rights that are regulated by lifting agreements. Typically a producer's rights allow him to produce between a minimum level of production and a maximum level of production within a set of time periods of different length. This production band may be flexible so that gas can be transferred between periods within predefined limits. Normally such production intervals are defined for single days, for years, and for intermediate periods in between like weeks and months.

Much of the natural gas produced is traditionally committed to take-or-pay contracts where the buyer has agreed to take a volume in a given import terminal for a sequence of years. Again there is flexibility on when to take the gas within a year (or other time periods) and typically the daily offtake is within a minimum and maximum level. The customer nominates volumes within the take-or-pay agreements, and the producer has to deliver. These nominations are often done weekly, with final nomination the day before production. In take-or-pay contracts the price is usually indexed to other commodities like oil, to temperature and several other parameters.

## **Transportation and Processing**

Natural gas is transported in pipelines by using compressors to create a higher pressure in the originating end of a pipeline, so that molecules will flow towards the end. Several pipelines may meet in a node in the transportation network. They may have different pressure at the end of the pipeline, but the input pressure of all pipelines going out of a transportation node must be smaller than the smallest end pressure of pipelines coming into the node, unless there is a compressor in the node.

An example of an export network for natural gas is the one you find at the Norwegian continental shelf which consist of 6600 km of pipelines. Here natural gas from different fields have different quality, in terms of energy content and its chemical composition (methane, ethane, propane and several more). Hence when natural gas from different fields is blended in the transportation network, it is critical to either keep track of the energy content of the blend or the total content of each natural gas component.

Some of the components can be extracted from the rich gas in processing plants. Processing facilities separate the rich gas into its various components. The components are liquefied petroleum gases like ethane, propane and butanes, which are exported by ship to separate commodity markets. The remaining dry gas (methane and some ethane) is transported in pipelines to import terminals in the UK, France, Belgium and Germany.

The organization of transportation markets varies a lot from region to region. One will often find that existing transportation rights already accounts for much of the available transportation capacity in the network. The Gas directive (European Union 1998) enforces undiscriminating third party access to the remaining capacity (see Section 2.2 for a discussion of The Gas directive). One way of resolving this is to introduce primary markets for transportation capacity where capacity can be booked. In some cases a fixed tariff is used for zones or for pipelines, in other cases bids are given for capacity and the market settled by some auction mechanism. In all cases the market is cleared and capacity is allocated by given transparent rules. In a secondary market with shorter time horizons transportation capacity is balanced with transportation needs for the different shippers.

In this paper we will only focus on the utilization of transportation capacity, while the capacity allocation regime and tariff regime is not discussed. For a further discussion on these topics see Dahl et al. (2003).

## **Storage**

There exist several types of natural gas storages. Abandoned oil and gas fields have high capacity and thereby a cost advantage. They also have low risk as geological data are known. In aquifers water is replaced with gas. They have higher risk as seismic investigation is necessary. Salt caverns are underground storage tanks washed out from salt layers. They typically have high costs. Injection rates, capacities, withdrawal rates and characteristics depending on filling rate vary between the types. Storages are important in planning models because they allow us to store natural gas close to the market and thereby use them to exploit spot-market variations. They also allow producers to produce in time periods where demand is low and to thereby utilize the available transportation capacity. Also they can be used as seasonal storages to smooth out seasonal effects. Whether storage is used as to avoid bottlenecks in the system in high demand periods or to utilize market possibilities, today's storage capacity is very limited when compared to the total production volumes.

## **Import Terminals and Markets**

The import terminals are landing facilities for natural gas where the export pipelines end. Natural gas is delivered here according to specification on minimum and maximum pressure and energy content. These characteristics are often specified by the contracts as terms of delivery. Further transportation from the import terminals are taken on by the buyer using a transmission network to distribute the gas to the end customers.

Originally these terminals were the points of deliverance for the many take-or-pay contracts. Recently these terminals have also been the location of the growing spot markets for natural gas and for financial derivatives on the spot market. The leading European hubs in terms of liquidity are the National Balancing Point in Great Britain, TTF in the Netherlands and Zeebrugge in Belgium.

A different type of markets is also emerging upstream in the pipeline network. The main idea here is to have standardized trading mechanisms for natural gas at some important locations in the network to be able to provide an additional flexibility for the producers. Upstream markets are used to perform trades of natural gas before transportation takes place. They are useful because there is a need for having standardized mechanisms to exchange gas between producers. They include additional flexibility for producers in terms of being able to stay within the limits of their own lifting agreements, transportation capacities and contract commitments in case of unexpected events or in case overselling or underselling of natural gas has occurred. The buyer of gas upstream also has the responsibility to transport the gas to downstream markets. Upstream markets are not as well developed as the other markets. Still the idea is old and the former variant was the less standardized bilateral long term swing agreements between different producers, allowing fields with little flexibility an option to draw gas from fields with more flexibility in volumes.

## **Liberalization and Regulation**

The European natural gas industry has developed rapidly over the past thirty years. The European Commission has worked toward strengthening the competition within the complete gas- and energy value chain. A breakthrough in this process came on the 22nd of June 1998 when the gas directive was passed in the European Commission (European Commission & Transport 2002). In the directive a stepwise liberalization of the European gas market is described. The key components of the gas directive are third party access to all transportation installations, division of activities within the firms in the value chain (physically or by accounting) and the possibility for certain consumers to obtain their gas from the supplier of their choice. The directive was followed by a second gas directive in 2003 (European Union 2003) which moved another step towards liberalization.

Another implication of the gas directive and of EU competition laws was the 2002 closing down of the Gas Negotiation Committee (GFU), the forum for coordinated gas sales from the Norwegian continental shelf. The GFU formerly coordinated the supply of Norwegian natural gas producers Statoil and Hydro. Now the sales are company based and rarely linked to a specific production field.

An expected result from these changes is that short-term markets will evolve for natural gas. Though liquidity is still low, there are already clear signs indicating

that short-term contracts and spot-trades will play an important role in the future. The prior market structure is dominated by long-term agreements and thus minimizes the uncertainty for the participants. In practice the producers take the price risk, as prices are fixed towards various indexes, while the buyers take the volume risks by going into long term agreements. The new markets will include short-term bilateral contracts, spot markets and financial markets. The introduction of short-term markets will most likely also lead to higher volatility and thus higher uncertainty.

Abolishment of the GFU-system and the introduction of a system where the individual companies are responsible for disposal of their own gas reserves called for a new access and tariff regime in the transportation network. The first step in the Norwegian transportation system was taken with the creation of Gassco AS in May 2001 under the provisions of a Norwegian White Paper. Gassco is assigned all the operator's responsibilities warranted in the Norwegian Petroleum Law and related Regulations. As a State owned company, Gassco AS should operate independently and impartially and offer equal services to all shippers. Systems operated by Gassco are the rich and dry gas systems previously operated by Statoil, Norsk Hydro and TotalFinaElf.

The models presented in this paper are simplified variants of models developed in co-operation with Gassco and Statoil to deal with the changes mentioned above.

## **2.3 A Natural Gas Transportation Model**

When modeling natural gas pipeline flow it is important to have a conscious view on how time and the dynamics of gas flow should be handled. The modeling of natural gas flow in continuous time has clear links to the process control paradigm (Hofsten 2000). Within this paradigm one normally uses active control, to operate the system according to a predetermined load and supply, finding a sequence of control actions which leads the system to a target state. The control regime often focuses on single processes or single components in the network. For our purpose we need to model a system of pipelines with a set of production fields, processing plants and markets. The natural choice is to look at mixed integer programming models from the modeling paradigm of mathematical programming. Here time is discretized. If the resolution of time periods is minutes or hours there is a need to model the transient behavior of natural gas. Some attempts on optimizing the transient behavior of a system of natural gas pipelines are Westphalen (2004) and Nowak & Westphalen (2003), but only systems of limited size and complexity can be handled. To be able to handle the complexity needed for our models, we leave the concept of modeling the transient behavior of natural gas and approximate the time dimension by discrete time periods of



such length that steady-state descriptions of the flow will be adequate. When the time resolution of the model are months, weeks, and maybe days, rather than minutes and hours, we can assume that the system is in a steady-state in each time period. The mathematical optimization models used to describe natural gas flow in the case of steady-state models are typical non-linear and non-convex. An approach using a non-linear formulation of the mathematical models is illustrated in De Wolf & Smeers (2000). We present here a linearized model based on mixed integer programming to optimize routing of natural gas in pipeline networks. We base our presentation on work done on linearization from Rømo, Tomasgard & Nowak (2004). Several examples on linearization of natural gas flow exist in the literature. For a recent PhD thesis on linearization of natural gas flow see Van der Hoeven (2004).

In this paper we describe the essential constraints needed to model the technological characteristics of natural gas flow in a steady-state setting. Issues like pressure, gas quality and gas components are dealt with from a pipeline transportation perspective. More detailed models very similar to the one we present here are today in use by Statoil and Gassco in the software package GassOpt developed by SINTEF. GassOpt is mainly used by the operator of the gas transportation system in the Norwegian sector of the North Sea. They are obliged to verify the delivery capabilities and robustness of the pipeline system transporting natural gas to European markets.

In the model presented in this section, we will focus on the transportation alone with the main purpose to meet demand for transportation generated by planned production profiles for the different fields. This typically represents the situation facing the neutral operator. The pipeline system is a natural monopoly, and is controlled by the authorities. This verification is also of strategic importance for the independent producers and customers in Germany, Belgium and France. The security of supply will influence the price possible to achieve for long term contracts, and contribute to infrastructure investment decisions, and GassOpt is one of the tools used to ensure maximum utilization of the infrastructure.

GassOpt itself focuses on analyzes of transportation possibilities. It can be used for optimal routing decisions from a flow maximization perspective. Also it is used to reroute natural gas when unexpected incidents lead to reduced capacity (in production units or pipeline). Thirdly, it can be applied at more tactical/operational level by a commercial player in capacity planning and capacity booking.

In this section we present a static model of one period. Demand for natural gas in the import terminal is assumed to be aggregated over the contracts in the terminals and planned production volumes given as constants to represent the license holders' production plans. So the main task of this model is to operate the transportation network to make sure demand is met by the planned production. In Section 4 we extend the model with several time periods and storage capabil-

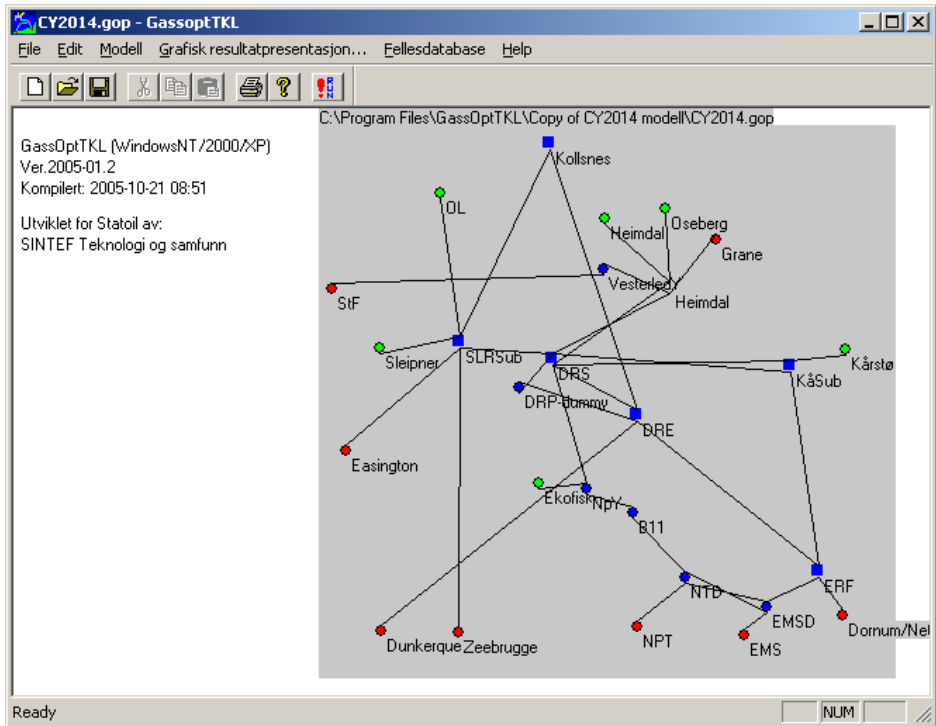


Figure 2.2: Network presentation in GassOpt

ities. In Section 5 we include contracts, markets and a portfolio perspective on managing the natural gas supply chain with stochastic prices and demand.

## The GassOpt Modeling Interface

In GassOpt, the underlying physical network is represented in a graphical modeling environment with nodes and arcs. The modeling tool is hierarchical and applies to general network-configurations. Figure 2.2 indicates the network complexity for the North Sea network. The squared nodes contain subsystems with further nodes and pipelines. When modeling the North Sea system we need approximately 75 nodes and 100 arcs to represent the network.

## The GassOpt Mathematical Model

This network model includes flow balances, blending of different gas qualities from different fields, processing nodes for extracting components of the natural gas, compressor nodes, node pressures and the nonlinear nature of pressure drop in pipelines. The model describes a steady-state situation where the network is in equilibrium in terms of pressures and natural gas mix. It is typically the kind of model used to model situations where flows are aggregated over a given time period. When the time period gets short enough, for example hours or minutes, this steady-state description will not be good enough because of the need to describe the transient behavior of natural gas flow. The objective for the optimization model is to ensure optimal routing and mixing of natural gas.

The model should make sure the nominated volumes are delivered to the import terminals within a time period. This objective can be achieved in several ways. Penalties are introduced in the objective function to influence the impact of the following goals:

1. Maintain planned production from the producers, where this is physically possible.
2. Deliver natural gas which meets quality requirements in terms of energy content.
3. Deliver within the pressure requirements in the contracts.
4. Minimize the use of energy needed in order to deliver the natural gas to the customers by minimizing the pressure variables.

A typical optimization case describes a specified state of the network, including expected production and demand (characterized by volume and quality), shutdown situations and turn-up capacity (additional available but unplanned production capacity) from production fields. In a normal situation, there will be several possible strategies to deliver the maximum amount of gas to the customers. To make the model generate and report these realistic flows, we have introduced penalty costs in the objective function on deviation from planned production, quality requirements, pressure agreements and the energy use. These penalty costs can of course theoretically interfere with and prevent us to achieve the main goal, to deliver in accordance with the demand of the customers. The tests we have performed on the full North Sea network, show that this ‘multi-criteria’ aspect does not sacrifice much of the maximal flow potential, but is rather used to choose between alternative solutions with about the same flow. In a fault situation, for example if a field or pipeline is down, the model will prioritize to deliver the nominated volumes in the import terminals. For more information about multi-criteria decision making, see for instance Rardin (1998).

Seen from an operator's point of view the model tries to meet the customer's requirements for a given state of the network: either by optimal routing of gas or by turning up production in fields with flexibility on the production side. In the last case we say that we use turn-up capacity, which is available in some fields with flexible production characteristics.

## Sets

Below the sets used in the mathematical description of the model is presented.

- $\mathcal{N}$  The set of all nodes in the network.
- $\mathcal{B}$  The set of nodes where gas flows are splitted into two or more pipelines.
- $\mathcal{M}$  Nodes with buyers of natural gas: typically import terminals.
- $\mathcal{I}(n)$  The set of nodes with pipelines going into node  $n$ .
- $\mathcal{O}(n)$  The set of nodes with pipelines going out of node  $n$ .
- $\mathcal{R}$  The set of nodes with processing capabilities.
- $\mathcal{S}$  The set of nodes with storage facilities.
- $\mathcal{K}(b)$  The set of contracts in node  $b \in \mathcal{B}$ .
- $\mathcal{C}$  The set of components defining the chemical content of the natural gas.
- $\mathcal{T}$  The set of time periods included in the model.
- $\mathcal{L}$  The set of breakpoints used to linearize the Weymouth equation.
- $\mathcal{Z}$  The set of split percentages used to discretize possible split fractions in split-nodes of the network.
- $\mathcal{Y}$  The number of discretized storage and injection rate levels used to linearize storage characteristics.

## Objective Function

Our goal is to route the gas flow through the network, in order to meet demand in accordance with contractual obligations (volume, quality and pressure). In the formulation given below, variable  $f_{im}$  is the flow of gas from node  $i$  into market node  $m$ ,  $p_{ij}^{in}$  is the pressure into the pipeline going from node  $i$  to  $j$ ,  $\epsilon_m^+$  and  $\epsilon_m^-$  is the positive and negative deviation from the contracted pressure level respectively,  $\Delta_g^+$  and  $\Delta_g^-$  represents underproduction and the use of turn-up in relation to the planned production in field  $g$ ,  $\delta_m^{l-}$  is the negative deviation from the lower quality level limit, and  $\delta_m^{u+}$  is the positive deviation from the upper quality level limit in market node. The value of the flow to the customer nodes is given by the constant  $\omega$ . Furthermore,  $\kappa$  is the penalty cost for pressure level,  $\varpi$  is the penalty cost for deviation from contracted pressure level,  $\chi$  is the penalty

cost for deviation from contracted quality to customers and  $\iota$  for use of turn-up.

$$\begin{aligned} \max Z = & \sum_{i \in \mathcal{I}(m)} \sum_{m \in \mathcal{M}} \omega_m f_{im} - \sum_{i \in \mathcal{N}} \sum_{j \in \mathcal{N}} \kappa p_{ij}^{in} - \sum_{m \in \mathcal{M}} \varpi (\epsilon_m^+ + \epsilon_m^-) \\ & - \sum_{g \in \mathcal{G}} \iota (\Delta_g^+ + \Delta_g^-) - \sum_{m \in \mathcal{M}} \chi (\delta_m^{l-} + \delta_m^{u+}) \end{aligned} \quad (2.1)$$

Energy consumption for transporting the natural gas is minimized through making the penalty cost ( $\kappa$ ) insignificant in size as compared to the value of the natural gas transported. This contributes to reduce the necessary build up of pressure to a minimum, without interfering with the correct volume, quality and pressure to the customer terminals. The penalty on using turn-up capacity will make sure that planned production in the fields is prioritized first, as long as it does not influence the throughput of the pipeline system. For most practical cases the contracted pressure level is not a soft constraint, and will then rather be put into a hard constraint instead of being penalized in the objective function.

## Constraints

**Production capacity** The following constraint says that the total flow out of a production node  $g$  cannot exceed the planned production of the field in that node. Here  $f_{gj}$  is the flow from production field  $g$  to node  $j$ :

$$\sum_{j \in \mathcal{O}(g)} f_{gj} \leq G_g, \quad g \in \mathcal{G}. \quad (2.2)$$

**Demand** This constraint says that the total flow into a node with customers for natural gas must not exceed the demand of that node:

$$\sum_{j \in \mathcal{I}(m)} f_{jm} \leq D_m, \quad m \in \mathcal{M}. \quad (2.3)$$

**Mass balance for node  $j$**  The following constraint ensures the mass balance in the transportation network. What flows into node  $j$  must also flow out of node  $j$ :

$$\sum_{i \in \mathcal{I}(j)} f_{ij} = \sum_{n \in \mathcal{O}(j)} f_{jn}, \quad j \in \mathcal{N}. \quad (2.4)$$

**Pressure constraints for pipelines** Offshore transportation networks often consist of very long pipelines without compression, where it is crucial to describe the pressure drops in the pipeline system. We use the Weymouth equation to

describe the flow in a pipeline as a function of input and output pressure. The Weymouth equation is described in e.g., Campbell (1992). In the Weymouth equation  $W_{ij}(p_{ij}^{in}, p_{ij}^{out})$  is the flow through a pipeline going from node  $i$  to node  $j$  as a consequence of the pressure difference between  $p_{ij}^{in}$  and  $p_{ij}^{out}$ :

$$W_{ij}(p_{ij}^{in}, p_{ij}^{out}) = K_{ij}^W \sqrt{p_{ij}^{in^2} - p_{ij}^{out^2}}, \quad j \in \mathcal{N}, i \in \mathcal{I}(j). \quad (2.5)$$

Here  $K_{ij}^W$  is the Weymouth constant for the pipeline going from  $i$  to  $j$ . This constant depends among others on the pipelines length and its diameter and is used to relate the correct theoretical flow to the characteristics of the specific pipeline. Figure 2.3 illustrates the Weymouth equation. The figure shows that the function in the interesting area (positive pressure levels) is one fourth of a cone. The cone starts in origo, and is limited by the inlet pressure axis, and the 45° line between the inlet pressure and outlet pressure axes.

Through Taylor series expansion it is possible to linearize Equation (2.5) around a point  $(PI, PO)$  representing fixed pressure into the pipeline and fixed pressure out of the pipeline respectively:

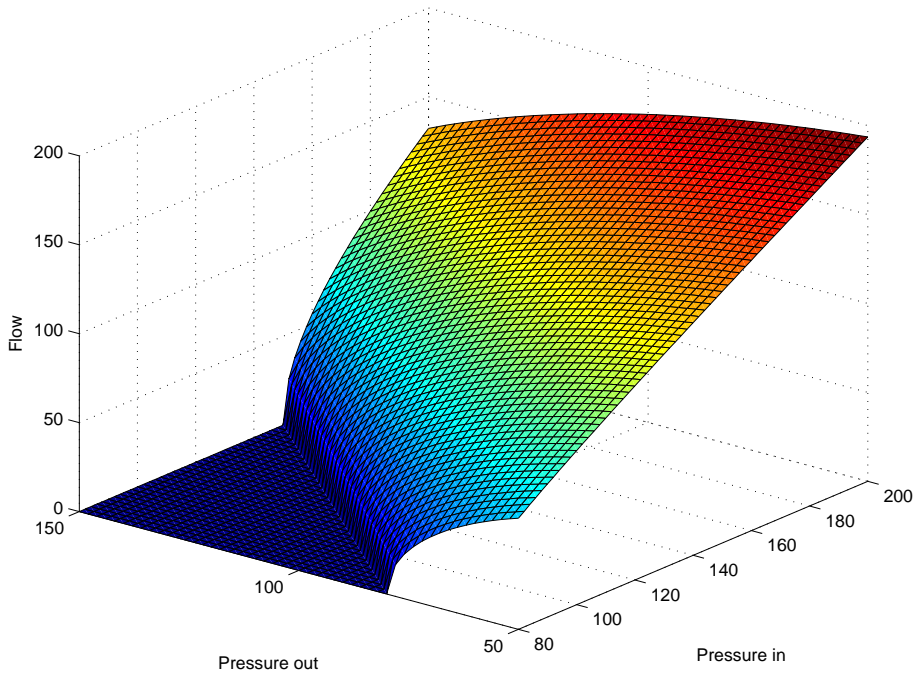
$$\begin{aligned} W_{ij}(p_{ij}^{in}, p_{ij}^{out}) \leq & W_{ij}(PI, PO) + \frac{\partial W_{ij}}{\partial p_{ij}^{in}}(p_{ij}^{in} - PI) \\ & + \frac{\partial W_{ij}}{\partial p_{ij}^{out}}(p_{ij}^{out} - PO), \quad j \in \mathcal{N}, i \in \mathcal{I}(j). \end{aligned} \quad (2.6)$$

We introduce a set of points to linearize this expression,  $(PI_l, PO_l)$ , where  $l = 1, \dots, L$ . Then we replace for each pipeline the nonlinear function (2.5) with  $L$  linear constraints of the type:

$$\begin{aligned} f_{ij} \leq & K_{ij}^W \frac{PI_l}{\sqrt{PI_l^2 - PO_l^2}} p_{ij}^{in} \\ & - K_{ij}^W \frac{PO_l}{\sqrt{PI_l^2 - PO_l^2}} p_{ij}^{out}, \quad j \in \mathcal{N}, i \in \mathcal{I}(j), l = 1, \dots, L. \end{aligned} \quad (2.7)$$

For any given pipeline flow, only one of these  $L$  constraints will be binding, namely the one that approximates the flow best. The planes described in (2.7) will be tangent to the cone at the line where the ratio between pressure in and out of the pipeline is equal to the ratio between  $PI_l$  and  $PO_l$ . Together the planes give an outer approximation of the cone. This approximation will consist of triangular shapes defined by these planes.

**Pipelines without pressure drop** For physical pipelines between nodes where the distances are very limited it is not necessary to model pressure drops by the



**Figure 2.3:** A three-dimensional illustration of how the Weymouth relates pressure at the inlet and outlet points to the capacity in the pipeline.

Weymouth equation. In this case a simple maxflow restriction is:

$$f_{ij} \leq F_{ij}, \quad j \in \mathcal{N}, i \in \mathcal{I}(j), \quad (2.8)$$

where  $F_{ij}$  is the capacity. In this case there is no pressure drop, so:

$$p_{ij}^{out} = p_{ij}^{in}, \quad j \in \mathcal{N}, i \in \mathcal{I}(j). \quad (2.9)$$

**Relationship between pressures into a node and out of a node** To achieve a relevant flow pattern, it is sometimes preferable to model the pressure out of all the pipelines going into the same node homogenously:

$$p_{in}^{out} = p_{jn}^{out}, \quad n \in \mathcal{N}, i \in \mathcal{I}(n), j \in \mathcal{I}(n). \quad (2.10)$$

Another important issue is the relationship between pressure in ingoing pipelines and the outgoing. In general for a node  $n$  the input pressure of all pipelines going out of  $n$  must be lower than the lowest pressure out of any pipeline going into node  $n$ , see Figure 2.4. There is one exception, and that is the case where a pipeline into the node has 0 flow. The end pressure of this arc is neglected. In the Equation (2.11) the variable  $\rho_{ij}$  is 0 for pipelines without flow and 1 for the others.  $M$  is a number which is large enough to not restrict the pressures when the flows are 0. Then the following constraints make sure that the input pressure of a pipeline leaving  $n$  is less than the output pressure of a pipeline ending in  $n$  as long as both pipelines have a flow larger than 0.

$$p_{nj}^{in} - p_{in}^{out} + M(\rho_{nj} + \rho_{in} - 1) \leq M, \quad n \in \mathcal{N}, i \in \mathcal{I}(n), j \in \mathcal{O}(n) \quad (2.11)$$

$$f_{nj} \leq M\rho_{nj}, \quad n \in \mathcal{N}, j \in \mathcal{O}(n) \quad (2.12)$$

$$\rho_{nj} = \begin{cases} i & \text{if flow from node } n \text{ to node } j \\ 0 & \text{otherwise.} \end{cases} \quad (2.13)$$

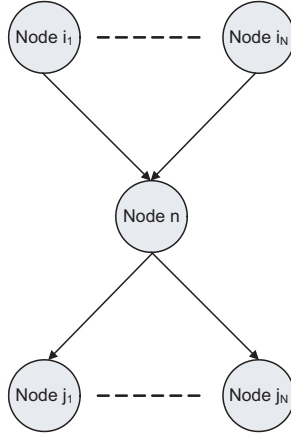
The Weymouth equation used gives an upper bound on the flow in a pipeline. This means that even if there is a pressure difference in a pipeline the flow can be zero. Because of this property it is not necessary to explicitly model the possibility of shutting down a pipeline. The model can simply put the flow to zero, and still keep the desired pressure. If omitting the constraints presented above one has to be aware of this when interpreting the results from the model.

**Modeling bidirectional pipelines** For pipelines designed to handle flows in both directions, the  $\rho_{ij}$  variable defined in the previous paragraph is used to determine the direction of flow. Equations (2.14) and (2.15) make sure that there only flows gas in one direction in the pipeline.

$$f_{ij} \leq M\rho_{ij}, \quad i \in \mathcal{N}, j \in \mathcal{O}(i), \quad (2.14)$$

$$\rho_{jn} = 1 - \rho_{nj}, \quad n \in \mathcal{I}(j), j \in \mathcal{I}(n). \quad (2.15)$$





**Figure 2.4:** Example of a split node with the possibility to shut down operation of one of the pipelines. The upper nodes,  $i$ , have pipelines going to node  $n$ . The lower nodes,  $j$ , have pipelines coming from node  $n$ . The index on  $i$  and  $j$  goes from 1 to  $N$ , where  $N$  is the total amount of nodes.

**Nodes with compression or pressure drop** In some cases we allow the pressure to increase in a node by using a compressor, or we force a pressure drop in the node. We here present a simplified formulation for modeling compression nodes where pressure can be build up or forced down. The compressor characteristics includes a compressor factor  $\Gamma$  used to limit how much the gas can be compressed in a node. If there is no compressor, this factor is 1. If there is a compressor, this  $\Gamma$  is a function of the flow  $f_n = \sum_{j \in \mathcal{I}(n)} f_{jn}$  into the node:

$$\Gamma_n(f_n) = \left( \frac{W^{max} \eta (K_a - 1)}{100 K_a f_n} + 1 \right)^{\frac{K_a}{K_a - 1}}, \quad n \in \mathcal{N} \quad (2.16)$$

In this expression, the parameter  $K_a$  is the adiabatic constant for a certain gas type,  $W^{max}$  is the power output capacity of the compressor, and  $\eta$  is the compressor efficiency, (Campbell 1992). Here we simplify this by using a constant compression factor independent of the flow. Then the pressure out of the compressor node  $n$  is limited by the compressor factor times the pressure into the node  $n$ :

$$\Gamma_n p_{jn}^{out} \geq p_{ni}^{in}, \quad n \in \mathcal{N}, j \in \mathcal{I}(n), i \in \mathcal{O}(n). \quad (2.17)$$

Pressure drop is modeled in the same way, but with a reduction factor  $\Theta_n$  instead of a compressor factor:

$$\Theta_n p_{jn}^{out} \geq p_{ni}^{in}, \quad n \in \mathcal{N}, j \in \mathcal{I}(n), i \in \mathcal{O}(n). \quad (2.18)$$

Here  $\Theta_n$  and  $\Gamma_n$  are constants, where  $0 < \Theta_n \leq 1$  and  $1 \leq \Gamma_n$ . The formulation is only meaningful if at most one of the factors is different from 1 in a node.

**Contracted pressure** It may be necessary to model the contracted pressure in nodes with customers. Most import terminals have a limited range around a target pressure  $P_m$  which they accept for incoming gas:

$$p_{im}^{out} + \epsilon_m^- - \epsilon_m^+ = P_m, \quad m \in \mathcal{M}, i \in \mathcal{I}(m). \quad (2.19)$$

Here  $\epsilon_m^-$  and  $\epsilon_m^+$  are negative and positive deviations from the target pressure. These deviations are penalized in the objective at a level reflecting how hard the pressure constraint is in practice.

It is also possible to specify restrictions for each pipeline for example for the pressure into and out of a given pipeline. Pressure restrictions often apply to nodes with compression or nodes where processing of the gas is being performed. These constraints are called technical pressure constraints. Examples are minimum and maximum pressure out of pipeline (represented by (2.20) and (2.21) respectively).

$$p_{ij}^{out} \geq P_{ij}^{min}, \quad j \in \mathcal{N}, i \in \mathcal{I}(j). \quad (2.20)$$

$$p_{ij}^{in} \leq P_{ij}^{max}, \quad j \in \mathcal{N}, i \in \mathcal{I}(j). \quad (2.21)$$

**Gas quality and energy content** In this model, gas quality can be specified in two different ways, focusing on combustion value (GCV) of the natural gas, or the content of  $CO_2$ . These properties are both technically and economically important for the customer. When dealing with  $CO_2$ , the customer accept a maximum content in terms of [mol %]. This is typically due to environmental taxes or to requirements related to avoiding corrosion in pipelines. If we focus on GCV, the customer accepts deliveries between a minimum and maximum combustion value. High GCV is in itself tractable as the energy content is higher, but in practice the plants using the natural gas are technically calibrated for a certain GCV-range. The quality is then measured in  $[MJ/Sm^3]$ . Here we only give the formulation for GCV:

$$Q_m^{min} \leq q_{im} \leq Q_m^{max}, \quad m \in \mathcal{M}, i \in \mathcal{I}(m), \quad (2.22)$$

where  $q_{im}$  is gas quality (GCV) in a pipeline going from node  $i$  to market node  $m$ . In practice we need more flexibility in the model by allowing reduced

quality in order to increase the flow. Modeling this as hard constraints could lead to situations where unexpected shutdowns of production fields or pipelines may lead to a complete stop in deliveries to a customer due to the contractual quality. If it is an alternative to get some deliverances, outside the contracted limits, but within what is technically acceptable the latter will be chosen. This tradeoff will be valued in economical terms as reduction in the customer price. We need the variables  $\delta_m^{l+}$  and  $\delta_m^{l-}$  to indicate the positive and negative deviation from the lower quality limit  $Q_m^{min}$  of customer node  $m$ . Likewise we need  $\delta_m^{u+}$  and  $\delta_m^{u-}$  to indicate the positive and negative deviation from the upper quality limit  $Q_m^{max}$ :

$$q_{im} + \delta_m^{l-} - \delta_m^{l+} = Q_m^{min}, \quad m \in \mathcal{M}, i \in \mathcal{I}(m), \quad (2.23)$$

$$q_{im} + \delta_m^{u-} - \delta_m^{u+} = Q_m^{max}, \quad m \in \mathcal{M}, i \in \mathcal{I}(m). \quad (2.24)$$

**Gas quality and blending** Gas quality is a complicating element because we have to keep track of the quality in every node and pipeline, and this depends on the flow. Where two flows meet, the gas quality out of the node to the downstream pipelines depends on flow and quality from all the pipelines going into the node. The flow in each pipeline is a decision variable in the model, and so is the quality out of each node. We assume that the resulting blending quality is common for all the downstream pipelines being connected to a node, and that it is decided by the convex combination of inflow qualities to the node:

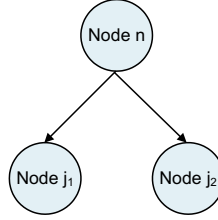
$$q_{ij} = \frac{\sum_{n \in \mathcal{N}} q_{ni} f_{ni}}{\sum_{n \in \mathcal{N}} f_{ni}}, \quad i \in \mathcal{N}, j \in \mathcal{O}(i), \quad (2.25)$$

or:

$$q_{ij} \sum_{n \in \mathcal{N}} f_{ni} - \sum_{n \in \mathcal{N}} q_{ni} f_{ni} = 0, \quad i \in \mathcal{N}, j \in \mathcal{O}(i). \quad (2.26)$$

This equation has two quadratic terms on the form  $q_{ni} f_{ni}$ . These terms can easily be reformulated in the following way: Define  $\alpha = q_{ni} - f_{ni}$  and  $\beta = q_{ni} + f_{ni}$ . Then  $q_{ni} f_{ni} = 1/4(\alpha^2 - \beta^2)$ . Linearizing  $\alpha^2$  and  $\beta^2$  is straightforward using Special Ordered Sets of type 2 (SOS2, see for instance Williams (1999)). In the SOS2 set at most two variables can be non-zero, and the two variables must be adjacent. Still this means that we need to move into solution techniques from integer programming, in particular branch and bound, so solution time will increase exponentially with the numbers of SOS2 sets needed.

**Modeling multi component flows** If we model the flow of  $C$  components of the natural gas we require that the split fractions of the components going into the different pipelines out of the node  $n$  is equal for all components. For simplicity let us assume we always have only two pipelines out of a split node  $n \in \mathcal{N}$  going



**Figure 2.5:** The flow is split in node  $n$  to node  $j_1$  and  $j_2$ .

to node  $j_1$  and  $j_2$  (see Figure 2.5). Let us also denote the first component in the set  $\mathcal{C}$  of components for  $c_1$ . All components are indexed from  $c_1, \dots, c_C$ . Then the relation of the volume split between  $j_1$  and  $j_2$  is equal for all components:

$$\frac{f_{nj_1}^{c_1}}{f_{nj_2}^{c_1}} = \frac{f_{nj_1}^c}{f_{nj_2}^c}, \quad n \in \mathcal{N}, c \in \mathcal{C}. \quad (2.27)$$

This is a quadratic expression, and we reformulate it using the equations (2.28) to (2.32). We need a set of binary variables  $\vartheta_{nz}$  where  $z = 1, \dots, Z$ , each representing the choice of a split percentage for the share of natural gas going to node  $j_1$ . The  $\vartheta_{nz}$  variable is modeled as a special ordered set of type 1 (SOS1), where only one variable can be non-zero (Williams 1999). For each  $\vartheta_{nz}$  we define a constant  $E_z$  giving the percentage related to the  $z$ . We also define a new variable  $e_{nz}$  representing the flow through node  $n$  of component  $c$  if  $\vartheta_{nz} = 1$ .

The first constraint says that the flow from  $n$  to  $j_1$  of component  $c$  equals the percentage  $E_z$  multiplied with the total flow through node  $n$  of the component  $c$ .

$$f_{nj_1}^c = \sum_{z=1}^Z E_z e_{nz}, \quad n \in \mathcal{B}. \quad (2.28)$$

The set  $\mathcal{B}$  consists of all split nodes in the network. Then we need to restrict the formulation so that only one  $\vartheta_{nz}$  is positive for each node:

$$\sum_{z=1}^Z \vartheta_{nz} = 1, \quad z \in \{1, \dots, Z\}, n \in \mathcal{B}. \quad (2.29)$$

The  $e_{nz}^c$  variables giving the flow through the node of each component is constrained by the capacity of the node, corresponding to the active  $\vartheta_{nz}$ .

$$\sum_{c \in \mathcal{C}} e_{nz}^c \leq F_n \vartheta_{nz}, \quad z \in \{1, \dots, Z\}, n \in \mathcal{B}. \quad (2.30)$$

We also require that what flows through the node of each component either goes to node  $j_1$  or to node  $j_2$ :

$$\sum_{z=1}^Z e_{nz}^c = f_{nj_1}^c + f_{nj_2}^c, \quad n \in \mathcal{B}, c \in \mathcal{C}. \quad (2.31)$$

And to make sure that there does not flow more out of the node of each component than what comes in:

$$f_{nj_1}^c + f_{nj_2}^c = \sum_{i \in \mathcal{N}} f_{in}^c, \quad c \in \mathcal{C}, n \in \mathcal{B}. \quad (2.32)$$

**Processing plants** Some of the gas components are extracted and sold in separate component markets. The extraction is handled in processing plants in the network. In the modeling of this process it is assumed that the volume of each component extracted is a constant fraction of the total volume of that component in a processing plant ( $A_r^c$ ). Hence, no decision on the configuration of the processing plant is made, but pressures and gas flows through a processing plant can be modeled by several processing nodes in sequence or parallel. This is expressed in equation (2.33). The mass balance for the processing plant nodes can then be formulated as in equation (2.34). The variable  $a_r^c$  is used to keep track of how much of component  $c$  is extracted from the flow in processing plant  $r$ .

$$a_r^c = A_r^c \sum_{i \in \mathcal{N}} f_{ir}^c, \quad c \in \mathcal{C}, r \in \mathcal{R} \quad (2.33)$$

$$\sum_{i \in \mathcal{N}} f_{ir}^c = \sum_{j \in \mathcal{N}} f_{rj}^c + a_r^c \quad (2.34)$$

**Modeling turn-up: flexibility in the production fields** Turn-up is an expression used for the flexibility present in some production fields. For example reduced transport capacity due to a shutdown in one part of the network may be compensated by turning up the planned production from other gas fields not directly affected by the reduced capacity. When modeling this turn-up capacity it is important to keep in mind that even if one are free to utilize this flexibility, it is not acceptable from a practical point of view that the model presents a flow allocation where fields with significant turn-up capacity will take over production from minor fields, which basically is not affected by the shutdown. The turn-up is only used to take over production from fields that for some reason are prevented to deliver. Hence, our first priority is to meet demand in the network and our second priority is to produce in accordance with the planned production at the fields.

We model this by adding a penalty cost for using turn-up in the objective to avoid turn-up to be used at the expense of normal production capacity in other fields. This works because not delivering gas to customers would generate a loss which is considerably higher than the small penalty put on using turn-up capacity.

The variables  $\Delta_g^-$  and  $\Delta_g^+$  represent underproduction and the use of turn-up in relation to the planned production of  $G_g$  for field  $g$ . As before  $f_{gj}$  is the flow from  $g$  to  $j$ :

$$\sum_{j \in \mathcal{O}(g)} f_{gj} + \Delta_g^- - \Delta_g^+ = G_g, \quad g \in \mathcal{G} \quad (2.35)$$

## 2.4 Management of Natural Gas Storages

As a consequence of the liberalization process in the natural gas industry, the natural gas markets have become more dynamic. The spot markets and the possibility to trade gas in forward markets have increased the importance of gas storages. In this section we discuss models for gas storage operations in a market with uncertain demand.

In order to discuss the management of natural gas storages, a couple of terms need to be established (see Figure 2.6 for an illustration of the terms):

**Storage capacity** gives the maximal volume of natural gas in the storages facility.

The storages capacity is limited by the physical properties of the storage.

**Volume of natural gas in the storage** is the total volume of natural gas in a given storage at a given time.

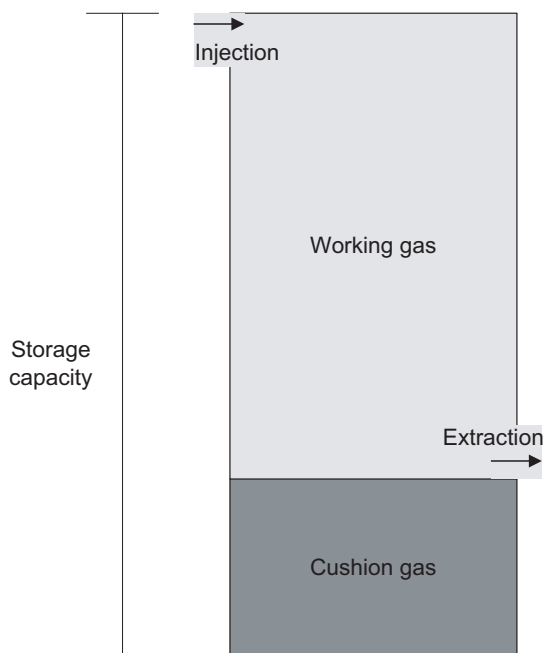
**Cushion gas** is the amount of gas needed to create necessary pressure in order to lift gas from the storage. The amount of cushion gas needed varies with the type of storage and the geological conditions at the storage location. For some types of storages the cushion gas requirement is as high as 80% of the total gas volume in the storage.

**Working gas** is the gas volume available during normal operation of the storage.

This corresponds to the total amount of gas in the storage subtracted the cushion gas.

### Storage Facilities

The most common storage facilities are abandoned oil- and gas reservoirs, aquifers, salt caverns and LNG-storages. In the following, a short overview of advantages and disadvantages of these possibilities will be given. For further discussion of storage facilities, see EIA (2002).



**Figure 2.6:** The complete square is the total storage capacity. The lower part of the figure is the cushion gas needed for operation of the storage, and the upper part of the figure is the gas currently available for extraction from the storage.

**Abandoned oil- and gas reservoirs** are the most common storage facility. One reason for this is the relatively low startup costs. The storage facility is already in place, and so is most of the surface installations needed. Another advantage of this type of storage is the fact that infrastructure is normally already in place. One major drawback is the amount of cushion gas needed for operation.

**Aquifer** is a porous, underground water-bearing layer which can be transformed into a storage facility by replacing the water with natural gas. When using abandoned oil- and gas reservoirs the geological properties are known, this is not the case when using aquifers. This adds risk to the development of this type of storages. Cushion gas in the amount of 80 to 90 % is needed for operation, and the development takes time and is costly. These storages are normally only used in locations where no oil- and gas reservoirs are available. One advantage of this type of storage is the relatively high delivery rate.

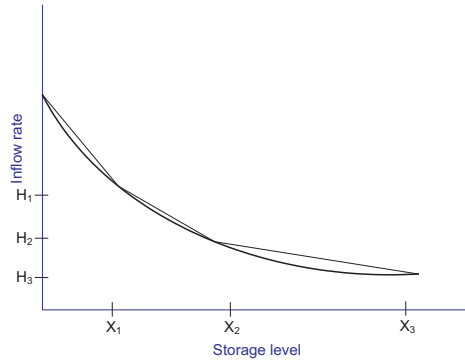
**Caverns** are created from underground salt or rock formations. In the salt caverns, water is used to dissolve halite and to shape cavities in natural salt formations. These cavities have the properties of a high-pressure gas container, with impenetrable walls. The storages have a high delivery capacity, and a cushion gas requirement of only approximately 25 %. The process of dissolving halite and shaping the cavities makes this alternative more expensive than the previous two alternatives.

**LNG-storages** are, in contrast to the previously presented alternatives, above-ground facilities. These storages consist of tanks containing liquefied natural gas (LNG) or liquefied petroleum gas (LPG). The capacity of these tanks is normally very limited compared to the other alternatives presented.

## Motivation for Utilization of Storages

The possibility of storing natural gas gives the participants increased flexibility with regards to production and transportation decisions. One important use of natural gas storages is to take advantage of the strong seasonal pattern in prices. Since the primary use of natural gas is for heating and production of electricity, the fundamental price determinant in the markets is the weather conditions. The demand is normally higher in winter than in summer, and the production capacity is also lower than the peak demand. This means that the monthly demand for natural gas may be much higher than the possible changes in production level can satisfy. The difference between production capacity and peak demand can to a certain degree be satisfied through utilization of storages. The use of storages can substitute for investments in new production fields and transportation capacity.





**Figure 2.7:** Illustration of the linearization of the injection rate of a storage.

Traditionally the storages have been used in order to ensure a high security of supply. When problems occurred either in the production or transportation facilities, storages could be used to supply the downstream participants. The storages operate as a security buffer in this case. With the development of short-term markets and volatile spot prices, the storages will be important for participants wanting to utilize the price fluctuations. Especially for gas producers not having a reservoir close to the market this will be important. It can take several days before a decision to change production level at the field will result in increased delivery in the market.

## Modeling Storages

The maximum in- and outflow rates of the storage varies with the current storage level. The maximal injection rate is a strictly decreasing convex function of the storage level. Likewise the outflow rate can be given as a strictly increasing convex function of the storage level. To be able to realistically represent the in- and outflow rates, the use of special ordered sets of type 2 is chosen (Williams 1999). An illustration of the implementation of the SOS2 is shown in Figure 2.7 for the injection rate. The storage levels are discretized by a set of constants  $X_1, \dots, X_Y$ , the corresponding injection rates are  $H_1, \dots, H_Y$  and the variables  $\nu_1, \dots, \nu_Y$  are used to give a convex combination of two of the points. This means that if  $\nu_y$  has a value different from 0, then only one additional variable can be non-zero. The only two candidates in this case are  $\nu_{y-1}$  or  $\nu_{y+1}$ . The storage

level at a given time  $t$  is represented by  $x_s^t$ .

$$\sum_i f_{is}^t \leq \sum_{y=1}^Y \nu_{ys}^t H_{ys}, \quad s \in \mathcal{S}, \quad (2.36)$$

$$\sum_{y=1}^Y \nu_{ys}^t = 1, \text{ SOS2}, \quad s \in \mathcal{S}, \quad (2.37)$$

$$x_s^t = \sum_{y=1}^Y \nu_{ys}^t X_y, \quad s \in \mathcal{S}, \quad (2.38)$$

$$x_s^t = x_s^{t-1} + \sum_{i \in \mathcal{I}(s)} f_{is}^t - \sum_{i \in \mathcal{O}(s)} f_{si}^t, \quad s \in \mathcal{S}. \quad (2.39)$$

The maximum and minimum levels of storage are modeled implicitly with the representation given. The maximal level (equal to the total capacity of the storage) is restricted by the inflow function. When the storage reaches the upper capacity level, the associated inflow rate is equal to zero. The minimum level (coming from the requirement of a certain level of cushion gas in the storage) is handled in a similar way: when the minimum storage level is reached, the associated outflow rate will be equal to zero.

## 2.5 Value Chain Optimization and Portfolio Management

We will here give a short description on how to include markets and portfolio optimization in the natural gas value chain. For more advanced models on portfolio optimization in the natural gas value chain see Rømo, Tomasgard, Fodstad & Midthun (2004) from which most of the ideas presented here originate. Other relevant references are Nygreen et al. (1998) which considers portfolio optimization for oil and gas fields in a strategic horizon and Ulstein et al. (2004) which considers tactical value chain coordination, but without stochasticity and without pressure constraints in the transportation network.

### Different Levels of Portfolio and Value Chain Integration

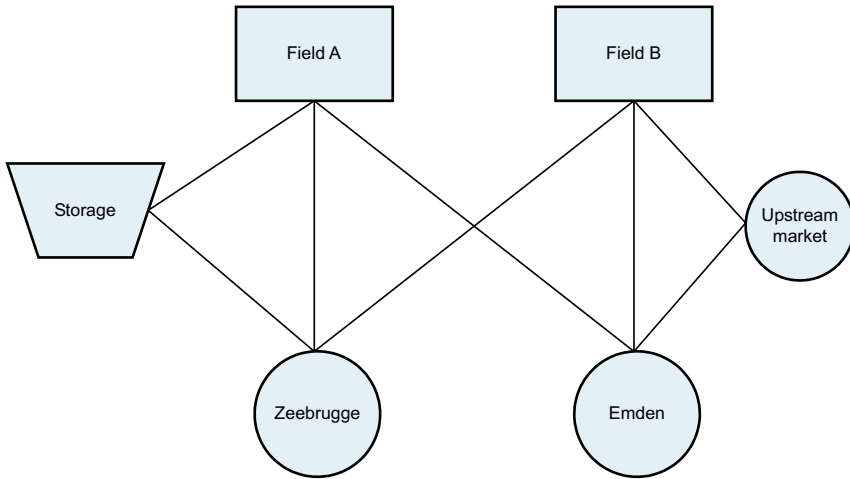
The models presented here have both a portfolio and a value chain perspective. These are important properties of a natural gas optimization model. The importance of these perspectives can be realized when considering the complexity of the transportation system. Due to the technical nature of the gas network, several physical and technical threshold-values exist. If such values are trespassed,

only minor incremental deliveries in one part can cause significant unintended reductions elsewhere. The bottlenecks in the transportation system make the flexibility incorporated in a system perspective valuable. We will not give all the previous formulations of the transportation network again, but each time period  $t$  in a value chain model will include transportation network constraints and variables like the ones from Section 3 with an additional index  $t$  on all variables.

The motivation behind the portfolio and value chain perspectives can be summarized by considering four levels of planning:

1. *Traditional production planning:* In this first level the model ensures balancing of the production portfolio with the contract portfolio. Stochastic demands and prices that are not perfectly correlated motivate a portfolio perspective on the planning, as the portfolio variation will be lower than the variation of the stochastic parameters of separate fields or contracts.
2. *Production and market optimization:* At this level markets are used to supplement the physical production in order to gain more from the physical production capabilities. The market can be used to resolve bottlenecks in the transportation network or on the production side. The purpose is to maximize the profit from production and contract obligations using also spot markets. At this level geographical swaps and time swaps of gas can be performed using the market, and they are used to fully utilize the flexibility in the system.
3. *Trading:* At this level contracts and financial instruments are traded independently of the physical production and contract obligations based on market opportunities. The trading is similar to the previous level in terms of using the spot market and financial instruments like futures and options, but the motivation is now speculation, not solving bottleneck problems. These trades are in no way connected to the physical production and contract obligations, unless the producer has market power.
4. *Risk management:* So far we have assumed the producer is risk neutral and tries to maximize expected profit. In that case it is enough to supplement physical production with trades in the spot market at level 2. If the producer is risk averse hedging the portfolio outcome using futures, forwards or options may be optimal.

The distinction between level 2 and 3 is clear in theory, but in practice the transition will be gradual.



**Figure 2.8:** Example of a natural gas network

### Utilization of Short-Term Markets in Value Chain Optimization

The use of short-term markets allows for considerable flexibility in the system. Consider the network in Figure 2.8. In a situation where field B needs to produce and the company has an obligation to deliver in a bilateral contract in Emden several possibilities exist:

- Field A supplies Emden, while field B sells spot in Zeebrugge
- The company may buy spot in Emden and the production from field B can be sold in the spot market in Zeebrugge.
- The company buys spot in Emden, while it sells the production from B spot in the upstream market.
- Storage might be used to supply Emden, while the production from field B is sold elsewhere.

These simple geographical swaps makes the system more flexible and gives the company the possibility to maximize the flow of natural gas (and the value of their production) beyond what traditional transportation planning would have done. For example bottlenecks in the production or in the transportation may be resolved or moved using the markets actively.

A different reason to use the markets is time swaps. Consider Figure 2.8 again. This time field B needs to produce in time 1, and the company has an obligation to deliver in time 2. Several options are then available to the company:

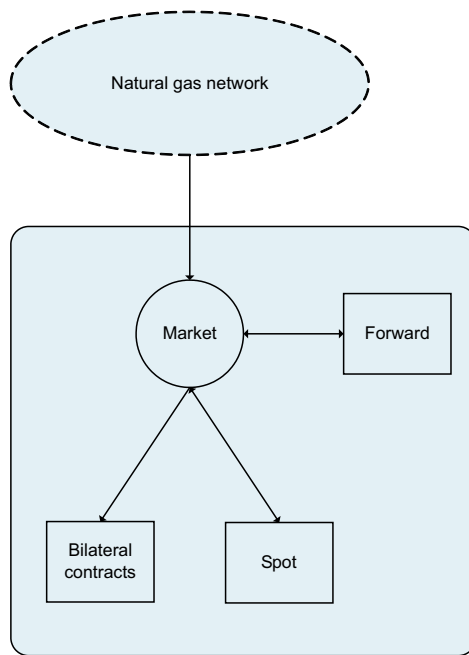
- In period 1 field B may supply storage, and in period 2 the storage supplies Emden.
- In period 1 field B can sell spot in Zeebrugge, and in period 2 either use a forward contract or buy spot in Emden.
- In period 1 field B can sell spot upstream, and then use either a forward contract or the spot market to supply Emden

This is just some of many possibilities that exist for geographical swaps and time swaps. The network considered is also very small. When expanding the network to, for instance, 20 fields, 80 pipelines and 10 markets, the number of possible routing decisions gets very large and the flexibility increases. It is this flexibility we try to capture when modeling the portfolios of production fields and contracts. The flexibility further increases when perfect spot markets are added. The need for flexibility comes from the fact that demands and prices are stochastic. The gain from portfolio thinking increases because they are not perfectly correlated. We assume the company is a price taker. For simplicity of notation, we assume there is only one company in the markets. If not, we would also need to model the other companies' transportation needs.

## Including Markets and Contracts

In Section 3 only aggregated deliveries to take-or-pay contracts in the different customer nodes  $m \in \mathcal{M}$  were considered. When including market transactions in the model a representation of the uncertainty in the price process is important. Based on this representation scenarios describing the uncertainty can be generated and optimal decisions in the interaction between the physical system and the market can be made. In this description some simplifications have been made. Only one company is considered, so no upstream market exists, the possibility of delaying production through lifting agreements will be disregarded, and only trades in the spot market will be considered. The possibility of trading forward contracts is only interesting for a risk adverse company. This will be discussed shortly at the end of this section.

Figure 2.9 illustrates how the market nodes are included in the model. The arrows show that gas might flow from the transportation network to the market. There is no flow from the market to the network (as would be the case for an upstream market). In addition, transactions within the market node can be performed. In the spot market the company can purchase or sell volumes of



**Figure 2.9:** The market node

natural gas. Obligations in the take-or-pay contracts can be fulfilled either by flow from the network to the market node, or by transactions within the market node.

## Modeling Stochasticity

We use the modeling paradigm of stochastic programming to represent uncertainty in the models, see for example Kall & Wallace (1994). Uncertainty is then represented in a scenario tree, see Figure 2.10. The nodes in the scenario tree represent decision points, and uncertainty is resolved along the arcs going out of a node with several branches. In practice decisions are only made when new information becomes known. A stage is the set of time periods elapsing between each time information is learned by the decision maker. Each stage in the tree typically consists of several time periods, but only nodes after a branching are decision points, as they are the only time periods when new information about the future is resolved. Still, decision variables are present in time periods where information is not resolved, hence the time periodization using time periods  $t$  reflect in which time period the decision has effect. In Figure 2.10 there are 3 time periods. Time periods 1 and 2 are in stage 1, starting with the decision in node 0 and ending just before the new decisions at stage 2 (in nodes 2, 6 and 10).

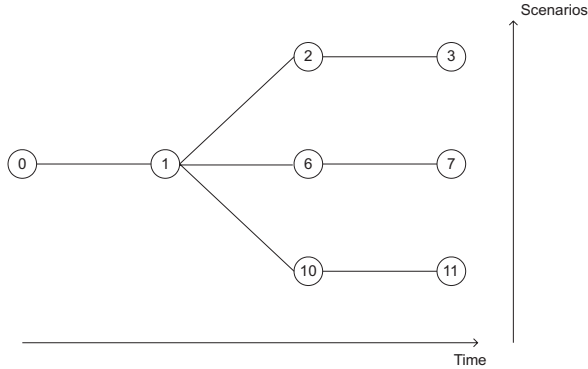
In a two-stage stochastic programming model we define a set of time periods  $t \in \mathcal{T}_1 = \{t_1, \dots, T_1\}$  belonging to the first stage where information is deterministic, and a set of time periods  $t \in \mathcal{T}_2 = \{T_1 + 1, \dots, T_2\}$  where some parameters are stochastic (as seen from  $t \in \mathcal{T}_1$ ). When time passes on and one enters the first  $t \in \mathcal{T}_2$ , uncertainty is resolved and also the remaining time periods can be considered deterministic.

In the model presented here we use a two-stage formulation for ease of notation. Several parameters are stochastic in reality. We will consider stochasticity in: contractual demands, contract prices and spot prices. We denote the stochastic contract price for contract  $k$  in customer node  $m$  at time period  $t \in \mathcal{T}_2$  as  $\tilde{\phi}_{mk}^t$ . Stochastic demand for contract  $k$  in customer node  $m$  at time period  $t$  is  $\tilde{\mu}_{mk}^t$ . The stochastic spot price is represented with  $\tilde{\psi}_m^t$ . The vector of all stochastic variables in time period  $t$  is  $\tilde{\xi} = (\tilde{\psi}_m^t, \tilde{\phi}_{mk}^t, \tilde{\mu}_{mk}^t)$ .

We use a tilde over the variable to reflect that it is stochastic (as seen from  $t \in \mathcal{T}_1$ ) and remove the tilde when the variable is deterministic. We then get the following:

$\tilde{\xi}_m^t$  Stochastic variables for customer node  $m$  in time period  $t \in \mathcal{T}_2$  seen from a point in time  $t' \in \mathcal{T}_1$ .

$\xi_m^t$  Deterministic parameters for customer node  $m$  in  $t \in \mathcal{T}_1$ , or  $t \in \mathcal{T}_2$  after uncertainty is resolved (Seen from a point in time  $t'$  where  $t' \in \mathcal{T}_2$ ).



**Figure 2.10:** An example of a scenario tree

A scenario tree can be constructed for example using price processes for natural gas or descriptions of the dynamic aspects of stochastic demand. We will not go in detail on how to do this here, but assume the scenario tree exists in the remaining part of this paper.

## The Objective

We describe the supply chain portfolio optimization model as a two-stage stochastic program with relatively complete recourse (Kall & Wallace 1994). The only stochasticity that is present is in the right hand side and in the objective. The typical length of a time period for a tactical planning model is one month, and the planning horizon would typically be 12 months, where for example the first 6 months would belong to  $\mathcal{T}_1$  and the last 6 months to  $\mathcal{T}_2$  in a two-stage formulation. The objective is to maximize expected profit taken into consideration cash flows and shortfall costs. Hence the objective can be described by summarizing the expected cash flow of the time periods. The cash flow of each time period  $t$  can be described as a function  $\Pi^t(x^{t-1}; \xi^t)$  (or  $\tilde{\xi}^t$  if stochastic) where  $x^{t-1}$  is the storage level in the start of the time period. The decision variables and constraints are equal in all time periods, except for initialization in time period 0 where only initial storage levels are defined  $x_{n,s}^0$  and for the terminal conditions at the end of the model horizon. We use the vector  $x^0$  to denote the initial level of all storages and  $x^t$  to denote the level of all storages in time period  $t$ . The profit function for time period  $t \in \mathcal{T}_1 \cup \mathcal{T}_2$  can be formulated as:

$$\Pi^t(x^{t-1}; \xi^t) = \sum_{m \in \mathcal{M}} \sum_{k \in \mathcal{K}} \phi_{mk}^t u_{mk}^t + \sum_{m \in \mathcal{M}} \psi_m^t (\zeta_m^{t-} - \zeta_m^{t+}), \quad (2.40)$$



where the first term is the income from delivery in contract  $k$  in market  $m$  at time  $t$  and the second term gives the profit from trading in the spot market in node  $m$  in time period  $t$ .

The two-stage stochastic program with fixed relatively complete recourse is:

$$\max \sum_{t \in \mathcal{T}_1} \Pi^t(x^{t-1}) + \mathcal{Q}(x^{T_1}), \quad (2.41)$$

where

$$\mathcal{Q}(x^{T_1}) = \max E_{\tilde{\xi}} \left[ \sum_{t \in \mathcal{T}_2} \Pi^t(x^{t-1}; \tilde{\xi}^t) + EGV(x^{T_2}) \right], \quad (2.42)$$

subject to a set of constraints representing transportation, production and markets. These constraints are mainly the constraints described earlier in this paper, but we will look closer at the ones changing because of the introduction of markets and contracts. The constraint sets are identical for all time periods  $t \in \mathcal{T}_1 \cup \mathcal{T}_2$ . For the last time period the objective includes the terminal value of the natural gas in storages expressed by the Expected Gas Value function,  $EGV(x^{T_2})$ . This function is described in more detail in Section 6.

The solution resulting from maximizing expected profits will normally be different from the solution reached with the objective function presented in Section 2.3. This means that the solution does not necessarily maximize the throughput in the network, or minimize the cost of achieving a given throughput. The solution will however show how the network should be managed in order to achieve the highest possible expected profit.

## Constraints Including Markets and Contracts

The mass balance in the market node for each time period and each scenario is expressed as:

$$\sum_{i \in \mathcal{I}(m)} f_{im}^t + \zeta_m^{t+} = \zeta_m^{t-} + \sum_{k \in \mathcal{K}(m)} \mu_{mk}^t, \quad \forall m \in \mathcal{M}, \forall t \in \mathcal{T}. \quad (2.43)$$

In (2.43),  $\zeta_m^t$  represent transactions in the spot market in node  $m$  in time period  $t$ . The  $+$  sign indicates purchases of natural gas whilst the  $-$  sign indicates sales. Delivery in contract type  $k$  in the node  $m$  in time period  $t$  are included in  $\mu_{mk}^t$ . The mass balance equation illustrates the flexibility gained by including markets in the model. It is no longer necessary to ship the gas to the market node in order to fulfill the contractual agreements, since the spot market can be utilized for this. This means that geographical and time swaps are now available to the company.

### **Risk Aversion**

In the discussion so far only the possibility for trading natural gas through the spot market has been discussed. For a risk neutral company that is maximizing expected profits this is an adequate approach. Since the forward price is a good predictor of the expected future spot price, trading in the forward market would on average be approximately equal to trading on the spot market (this is based on a simple arbitrage argument, see for instance Hull (2003)). The fact that natural gas is a commodity makes the argument less obvious, but under some assumptions still valid. In the case where the company is risk averse however the situation changes and some tools to handle risk management are needed. The inclusion of a forward market then gives the company the possibility to hedge, that is: to reduce the risk of their position. By trading forward contracts a given price can be locked in on advance.

In this case the company will no longer maximize expected profits from their operations, but rather maximize a utility function that incorporates the risk aversion of the company. Another way of doing this is to introduce a penalty function that will put extra cost in the objective function on deviations from some target profit value. In addition to the change in the objective function, the mass balance in the market node (see (2.43)) will be changed to incorporate the possibility to trade in the forward market.

### **Solution Times**

The complexity of the models introduced in this paper to a large extent depends on the modeling of the gas components. The inclusion of gas components adds a large number of integer variables to the problem. When excluding the gas components, a stochastic model with a network consisting of approximately 80 nodes and 1000 scenarios, can be solved within an hour. This problem will have approximately one million rows, one and a half million columns, four million non-zero elements and fourteen thousand binary variables. When including gas components the solution time increase significantly, and it is difficult to find an optimal solution. For a physical system similar to the one above, with 100 scenarios and 10 breakpoints (see Section 2.3), a solution with an integrality gap of 4% to 5 % typically can be reached within 12 hours. If the objective is only to maximize flow in a static model, solution times are within minutes when components are omitted and increases correspondingly when components are added.

## 2.6 The Expected Gas Value Function (*EGV*)

So far no considerations have been made with respect to how the final period in the planning horizon will be handled. The model presented so far will most likely end up with a very low storage level, and the production might also be higher than optimal when considering a longer horizon (since the value of the gas still contained in the reservoirs is neglected).

In order to handle the end-of-horizon problem, several possibilities exist. One way of handling the storage problem is to set a target value for the storage level at the end-of-horizon, for instance the starting level.

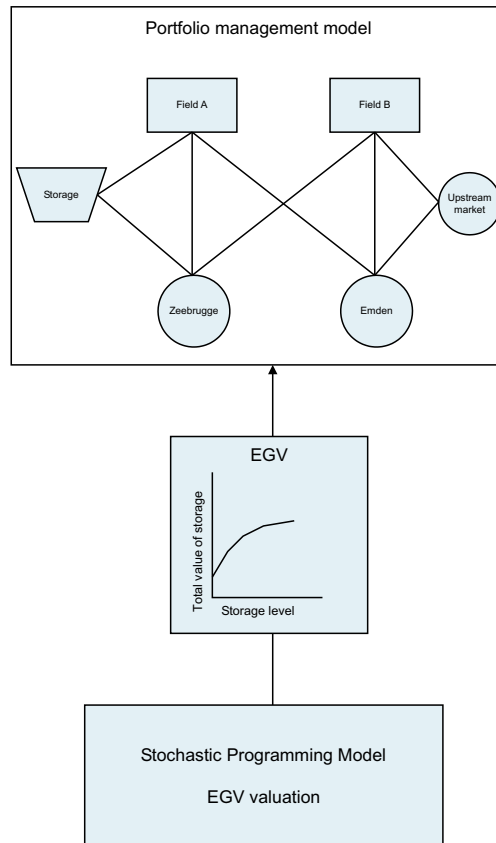
$$x_s^T \geq x_s^0 \quad (2.44)$$

This level might also be made dependent on various factors, such as the season in which the end-of-period belongs. This way of modeling the end-of-period however allows for limited flexibility and also neglects the true value of the gas contained in the storage. A way of determining the optimal level for the storages in the last period is by using the expected gas value function.

The Expected Gas Value function (*EGV*) gives an estimate of the value of a unit of gas in storage at some point in time  $t$ , based on expectations for the future development of the spot price of natural gas. When the *EGV* is used as a boundary value, the alternative value of the natural gas in storage is thereby included. This alternative value comes from the opportunities present after the end of the model horizon. Hence for each end-of-horizon storage level, the *EGV* must reflect the value of an optimal out-of-horizon strategy for injecting gas in the storage and selling gas from the storage.

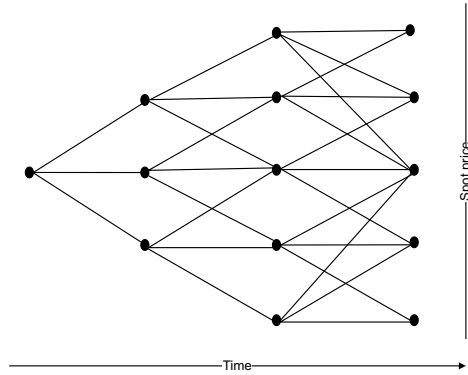
If high prices are expected in the future, the *EGV* will encourage a high storage level in final time period  $T_2$ , whilst if lower prices are expected the optimal level in period  $T_2$  may be lower. Figure 2.11 illustrates how the *EGV* is included in the existing optimization model. As the figure shows, the estimation of *EGV* is performed independently from the value chain model and the purpose is to give a boundary condition for the value of gas.

An important element in the model used to estimate *EGV* is the development of the natural gas spot price represented through spot price curves. These can be modeled using stochastic processes. Several versions of such models exist, for an overview of some of them, see Schwarz (1997). Based on the chosen price model, scenarios describing possible future outcomes can be constructed (see Figure 2.12). Hence, for any given initial storage level a strategy is found for injection and withdrawal of natural gas based on a stochastic process for the gas price. In practice this is a real-options approach used to value the value of gas in the storage. The option value in gas storages comes from the operational flexibility. The company can switch between injection, withdrawal or idle modes, depending



**Figure 2.11:** The estimation of the *EGV* is performed in a stochastic optimization model that is independent of the existing optimization model. The *EGV* is then used in the value-chain model as a boundary value on the gas in storage and reservoirs.

on the price development. For references on real-options, see for instance Hull (2003). It is possible to do this estimation both for individual storages, and also for the combination of all or some of the storages in the network. In the latter case a more complicated model is needed for estimation of the *EGV*.



**Figure 2.12:** Representation of the development of the spot price of natural gas. In this case a recombining trinomial tree. The arcs in the figure represent price movements, while the nodes represent different price scenarios.

In the following, an example of how the *EGV* can be calculated is given. The procedure is based on Scott et al. (2000) and Manoliu (2004), and use a stochastic dynamic programming framework. For references to similar work in hydro power, see for instance Pereira et al. (1999), Pereira & Pinto (1991). After choosing a stochastic model to represent the price of natural gas, a discrete approximation of the storage facility state space is made. A tree similar to the one constructed for the spot price (Figure 2.12) can be constructed also for the storage level. In this case the nodes represent different storage levels, while the arcs represent injection and withdrawal of natural gas in the storage. A multilevel tree representing the spot price and the amount in storage is then created. The valuation is performed by backward induction through the tree. The option value is calculated in each node by taking the maximum of the decision values of hold, injection and withdrawal. The hold decision value is equal to the expectation of the option value of the next steps, when storage level is unaltered. The injection value is the negative value of gas injected in this period, plus the expected value of increased storage level in future nodes. The withdrawal value is then the value of releasing gas in this period, plus the expectation of option values of decreased storage levels in coming nodes. This can be illustrated by (2.45), which shows

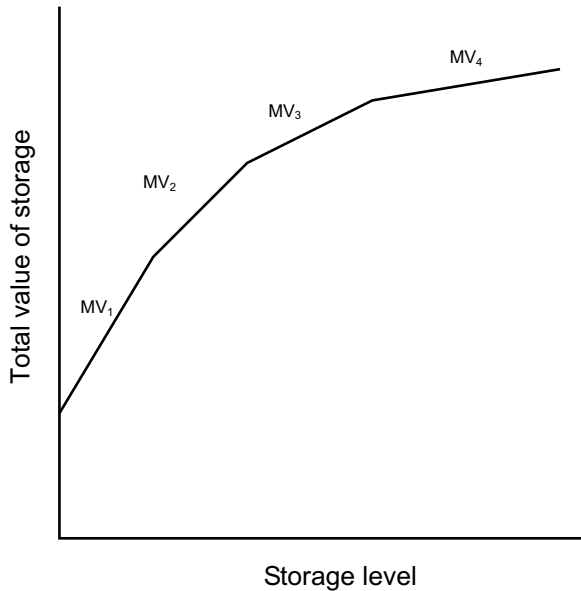
the value in a given node in the tree:

$$I^t(\tau^t) = \pi^t(\varphi^t) + I^{t+1}(\tau^{t+1}). \quad (2.45)$$

$I^t(\tau^t)$  is the value of storage level  $\tau$  in time period  $t$  in the node considered. This is determined by the value of flow  $\pi^t(\varphi^t)$ , (where  $\varphi^t$  is the volume injected or withdrawn in period  $t$ ) in the node in period  $t$  plus value of the storage level  $\tau^{t+1}$  in the next time period (in nodes following the considered one). The storage level is updated according to (2.46):

$$\tau^{t+1} = \tau^t + \varphi^t. \quad (2.46)$$

An illustration of a gas value function is given in Figure 2.13. The challenge is in finding the appropriate total value for each level of storage, as well as finding the breakpoints.



**Figure 2.13:** An example of an expected gas value function. The MVs shows the expected marginal value of gas for various levels of storage. This is the additional value of one more unit of natural gas in the storage.

Even though short-term markets for natural gas are developing in Europe, the liquidity in these markets is still very limited. This lack of liquidity makes estimation of the spot-price process difficult, and therefore also estimation of the

*EGV* difficult. Given that a spot-price model can be modeled for any given time horizon, a time-horizon of a couple of years may be appropriate for estimating the *EGV*. As the time-horizon for estimation is increased, the discount rate will make the gas value in the last periods decrease strongly.

## 2.7 Conclusions

In this paper we have gradually introduced the complexity of a stochastic optimization model for the natural gas value chain. We focus on coordination of the different levels of the chain and on a portfolio perspective. We started out by defining necessary constraints for a steady-state formulation of the underlying transportation network, supporting multi commodity flows and pressures. Next we introduced the time aspect and the use of storages. Thereafter we introduced stochasticity in demands and prices and gave a stochastic programming formulation for a portfolio optimization model. Natural extensions of this model would be contract selection and more advanced modeling of the production flexibility reflected by lifting agreements. Finally we defined the Expected Gas Value function and explained its use for giving the terminal value of stored natural gas and indicated how to calculate it.

Most of the model formulations presented here are simplified variants of models that are implemented for commercial use on the Norwegian continental shelf. In this paper we have taken the position of a large producer, but many of the formulations would be relevant for more general models focusing on other parts of the natural gas value chain.

## Appendix

### 2.A Notation and Definitions

#### Sets

- $\mathcal{N}$  The set of all nodes in the network.
- $\mathcal{G}$  The set of nodes in the network with production fields .
- $\mathcal{B}$  The set of nodes where gas flows are splitted into two or more pieplines.
- $\mathcal{M}$  Nodes with buyers of natural gas: typically import terminals.
- $\mathcal{I}(n)$  The set of nodes with pipelines going into node  $n$ .
- $\mathcal{O}(n)$  The set of nodes with pipelines going out of node  $n$ .
- $\mathcal{R}$  The set of nodes with processing capabilities.
- $\mathcal{S}$  The set of nodes with storage facilities.
- $\mathcal{K}(b)$  The set of contracts in node  $b \in \mathcal{B}$ .
- $\mathcal{C}$  The set of components defining the chemical content of the natural gas.
- $\mathcal{T}$  The set of time periods included in the model.
- $\mathcal{L}$  The set of breakpoints used to linearize the Weymouth equation.
- $\mathcal{Z}$  The set of split percentages used to discretize possible split fraction in split-node of the network.
- $\mathcal{Y}$  The number of discretized storage and injection rate levels used to linearize storage characteristics.

#### Indexes

- $n$  Used for nodes in general.  $n \in \mathcal{N}$ . When more indexes are needed,  $i$  and  $j$  will be used.
- $g$  Used for nodes with production fields,  $g \in \mathcal{G}$ .
- $b$  Split nodes,  $m \in \mathcal{M}$ .
- $m$  Customer nodes  $b \in \mathcal{B}$ .
- $r$  Used for nodes with processing plants.
- $s$  Storage facility  $s \in \mathcal{S}$ .
- $k$  Contract  $k \in \mathcal{K}$ .
- $c$  Component  $c \in \mathcal{C}$ .
- $t$  Time period  $t \in \mathcal{T}$ .
- $l$  Breakpoits in linearized Weymouth restrictions.
- $z$  Breakpoits in linearization of split percentages in split nodes.
- $y$  Breakpoits for linearization of injection rate levels in storages.



## Constants

$G_g$	Planned production [ $Sm^3/ t $ ] in field $g \in \mathcal{G}$ .
$F_{ij}$	Upper limit for flow through the pipeline from node $i \in \mathcal{N}$ to node $j \in \mathcal{N}$ .
$F_n$	Upper limit for flow through node $n \in \mathcal{N}$ .
$P_n^{max}$	Max pressure [bar] into a node $n \in \mathcal{N}$ .
$P_{ij}^{max}$	Max pressure [bar] into the pipeline from node $i \in \mathcal{N}$ to node $j \in \mathcal{N}$ .
$P_{ij}^{min}$	Min pressure [bar] out of the pipeline from node $i \in \mathcal{N}$ to node $j \in \mathcal{N}$ .
$P_b$	Target pressure [bar] for deliverances to a customer node $b \in \mathcal{B}$ .
$Q_n^{max}$	Max energy content requirement for gas deliverances to node $n \in \mathcal{N}$ . Energy quality is given by (GCV or $CO_2$ ) or $\frac{[MJ/Sm^3]}{[mol\%]}$ , where GCV is the (Gross Caloric Value).
$Q_n^{min}$	Min energy content requirement for gas deliverances to node $n \in \mathcal{N}$ .
$D_b$	Demand in standard cubic meter pr time unit [ $Sm^3/ t $ ] for natural gas in node $b \in \mathcal{N}$ .
$S_l$	Storage capacity [ $Sm^3/ t $ ] in node $s \in \mathcal{S}$ .
$K_{ij}^W$	The Weymouth constant is used as a constant in an empirical expression for linking flow and pressure in pipelines.
$A_r^c$	Fraction of component $c$ in processing plant $r$ that is extracted from the flow.
$PI$	Fixed point for pressure into a pipeline.
$PO$	Fixed point for pressure out of a pipeline.
$\Gamma_n$	Compressor factor in node $n \in \mathcal{N}$ .
$\Theta_n$	Pressure reduction factor in node $n \in \mathcal{N}$ .
$\eta$	Compressor efficiency.
$K_a$	Adiabatic constant for a certain gas type.
$W^{max}$	Power output capacity of the compressor.
$\omega_b$	Value of gas to customer $b$ .
$\kappa$	Penalty cost for pressure level.
$\varpi$	Penalty cost for deviation from contracted pressure level.
$\iota$	Penalty cost for use of turn-up.
$\chi$	Penalty cost for deviation from contracted quality to customers.
$E_z$	Gives the split percentage related to a given $z$ in linearization of split nodes.
$X_y$	Discrete representations of storage level in linearization of storages.
$H_y$	Discrete representations of injection rates in storages.

## Decision Variables

- $f_{ij}^c$  Flow from node  $i \in \mathcal{N}$  to node  $j \in \mathcal{N}$  of component  $c$ .  
In some cases index  $c$  is omitted when we do not consider multi commodity flow.
- $f_n$  Total flow into node  $n$ .
- $e_{nz}$  Flow through node  $n$  of component  $c$  used for linearization in splitting nodes  $m \in \mathcal{M}$ .
- $p_{ij}^{in}$  Pressure [bar] into the pipeline going from node  $i$  to node  $j$ .
- $p_{ij}^{out}$  Pressure [bar] out of the pipeline going from node  $i$  to node  $j$ .
- $q_{ij}$  Gas quality ( $GCV$  or  $CO_2$ ) in pipeline going from node  $i$  to node  $j$ .
- $\nu_y$  Give convex combinations of  $X_y$  and  $H_y$ .
- $\sigma_{in}$  Equal to 1 if flow from  $i$  to  $n$ , otherwise 0.
- $\vartheta_{nz}$  Binary variable representing split percentage in node  $n$ .
- $a_r^c$  Amount extracted of component  $c$  in plant  $r$ .
- $\rho_{ij}$  Equal to 1 if flow goes from  $i$  to  $j$ , otherwise 0.
- $\zeta_m^{t-}$  Volume sold in spot market  $m$  in time period  $t$ .
- $\zeta_m^{t+}$  Volume bought in spot market  $m$  in time period  $t$ .
- $\delta_b^{l+}$  Positive deviation from the lower quality limit  $Q_b^{min}$  of customer node  $b$ .
- $\delta_b^{l-}$  Negative deviation from the lower quality limit  $Q_b^{min}$  of customer node  $b$ .
- $\delta_b^{u+}$  Positive deviation from the upper quality limit  $Q_b^{max}$  of customer node  $b$ .
- $\delta_b^{u-}$  Negative deviation from the upper quality limit  $Q_b^{max}$  of customer node  $b$ .
- $x_s^t$  The storage level at a given time  $t$  in a storage  $s \in \mathcal{S}$ .
- $\epsilon_b^+$  Positive deviation from the contracted pressure to customer  $b$ .
- $\epsilon_b^-$  Negative deviation from the contracted pressure to customer  $b$ .
- $\Delta_g^+$  Positive deviation from the planned production in field  $g$ .
- $\Delta_g^-$  Negative deviation from the planned production in field  $g$ .

## Functions

- $EGV^t(x_s)$  Expected gas value in time period  $t$  as a function of the storage level in storage  $s$ .
- $W_{ij}(PI, PO)$  Flow resulting from pressure difference between Pressure in,  $PI$  and pressure out,  $PO$ , of a pipeline according to the Weymouth equation.
- $\Gamma(f_n)$  Compressor factor as a function of flow  $f_n$  into the node  $n \in \mathcal{N}$ .

## Stochastic Variables

$\tilde{\phi}_{bk}^t$  Contract price for contract  $k$  in customer node  $b$  in time period  $t$ .

$\tilde{\mu}_{bk}^t$  Demand for contract  $k$  in customer node  $b$  in time period  $t$ .

$\tilde{\psi}_m^t$  The spot price in market  $m$  in time period  $t$ .

$\tilde{\xi}^t$  The vector of all stochastic variables  $\tilde{\phi}^t$ ,  $\tilde{\mu}^t$  and  $\tilde{\psi}^t$ .

In time periods where these parameters are not stochastic or where uncertainty is resolved, the tilde is dropped in the variable name.



## Bibliography

- Campbell, J. (1992), *The Equipment Modules*, Gas Conditioning and Processing, 7 edn, Norman, Okla.
- Dahl, H., Rømo, F. & Tomasgard, A. (2003), An optimisation model for rationing-efficient allocation of capacity in a natural gas transportation network, *in* 'Conference Proceedings: IAEE Praha'.
- De Wolf, D. & Smeers, Y. (2000), 'The gas transmission problem solved by an extension of the simplex algorithm', *Management Science* **46**(11), 1454–1465.
- EIA (2002), 'The basics of underground natural gas storage'.  
[http://www.eia.doe.gov/pub/oil\\_gas/natural\\_gas/analysis\\_publications/storagebasics/storagebasics.pdf](http://www.eia.doe.gov/pub/oil_gas/natural_gas/analysis_publications/storagebasics/storagebasics.pdf).
- European Union (1998), 'Directive 98/30/EC of the european parliament and of the council'.
- European Union (2003), 'Directive 2003/55/EC of the european parliament and of the council'.
- European Commission, D.-G. f. E. & Transport (2002), 'Opening up to choice: Launching the single european gas market', Office for Official Publications of the European Communities.
- Hofsten, K. (2000), *Model-Based Dynamic Control and Optimization of Gas Networks*, PhD thesis, NTNU, Trondheim.
- Hull, J. (2003), *Options, Futures and Other Derivatives*, fifth edn, Prentice Hall International, Upper Saddle River, N.J.
- Kall, P. & Wallace, S. W. (1994), *Stochastic Programming*, John Wiley & Sons, Chichester.
- Manoliu, M. (2004), 'Storage options valuation using multilevel trees and calendar spreads', *SunGard Energy Systems, New York*. To appear in *International Journal of Theoretical and Applied Finance*.
- Nowak, M. & Westphalen, M. (2003), A linear model for transient gas flow, *in* 'Proceedings of ECOS', pp. 1751–1758. available as SINTEF-report STF 38S03601.

- Nygreen, B., Christiansen, M., Bjørkvoll, T., Haugen, K. & Kristiansen, Ø. (1998), ‘Modelling norwegian petroleum production and transportation’, *Annals of Operations Research* **82**, 251–267.
- Pereira, M., Campodónico, N. & Kelman, R. (1999), Application of stochastic dual DP and extensions to hydrothermal scheduling, Technical report, PSRI.
- Pereira, M. & Pinto, L. (1991), ‘Multi-stage stochastic optimization applied to energy planning’, *Mathematical Programming* **52**, 359–375.
- Rardin, R. L. (1998), *Optimization in Operations Research*, Prentice Hall, Upper Saddle River, New Jersey.
- Rømo, F., Tomasgard, A., Fodstad, M. & Midthun, K. (2004), Stochastic optimization of the natural gas value chain in a liberalized market, Technical report, SINTEF, Trondheim, Norway.
- Rømo, F., Tomasgard, A. & Nowak, M. (2004), Steady-state optimization of natural gas pipeline flow, Technical report, SINTEF, Trondheim, Norway.
- Schwarz, E. (1997), ‘The stochastic behavior of commodity prices: Implications for valuation and hedging’, *The Journal of Finance* **52**(3), 923 – 973.
- Scott, T., Brown, H. & Perry, N. (2000), ‘Storing true value?’, *Energy and Power Risk Management* .
- Ulstein, N., Nygreen, B. & Sagli, J. (2004), Tactical planning of offshore petroleum production. Working paper, NTNU, Trondheim.
- Van der Hoeven, T. (2004), Math in Gas and the Art of Linearization, PhD thesis, International business school and research center for natural gas, Groningen, The Netherlands.
- Westphalen, M. (2004), Anwendungen der Stochastischen Optimierung im Stromhandel und Gastransport, PhD thesis, University Duisburg-Essen (Germany).
- Williams, H. P. (1999), *Model Building in Mathematical Programming*, 4th edn, John Wiley & Sons, Chichester.

## Paper II

Kjetil T. Midthun, Mette Bjørndal and Asgeir Tomasgard:

### *Modeling optimal economic dispatch and flow externalities in natural gas networks*

*Submitted to international journal*





## Chapter 3

# Modeling optimal economic dispatch and flow externalities in natural gas networks

### **Abstract:**

We present a combined framework for modelling the technological issues of gas transportation and analysis of natural gas markets. In our framework we model the optimal dispatch of supply and demand in natural gas networks, with different objective functions, i.e., maximization of flow, and different economic surpluses. The models take into account the physical structure of the transportation network, and examine the implications it has for economic analysis. More specifically there are externalities in pipeline networks due to pressure constraints and system effects. Incremental increase in production in one part of the network may cause significant reductions elsewhere. The proposed network flow model for natural gas takes into account pressure drops and system effects when representing network flows. Pressure drops are modelled by the Weymouth equation. The Weymouth equation is linearized such that it is possible to perform economic analysis in large networks within our framework. The importance of combining economics with a model for pressure drops and system effects is illustrated by small examples.

## 3.1 Introduction

In this paper, we present a model for analyzing the optimal economic dispatch of natural gas in pipeline networks. Our approach combines a framework for modeling the technological characteristics of natural gas flows with optimization modeling of markets. The economic objectives include maximization of social surplus, consumer surplus and producer surplus. During the last years, the liberalization process in Europe and other places in the world, has led to an increased interest in such market-oriented models, including the spatial demand and supply for the commodity in the optimization of the transportation system. In the existing literature, we have found no approach that combines the modeling of the technology of natural gas flows with economic analysis of the transportation system.

In our paper, we show that it is important to represent the underlying physical properties, like the relation between flow and pressure, pressure drops and

resulting system effects, in the economic dispatch models. The inclusion of the technology leads to interesting, and in some cases, surprising results when optimizing the operation of the network. We show examples of the errors that will be made if the technology is not modeled, and we illustrate and discuss the externalities that arise from system effects in the network. The linearization of the gas flow equations will make it computationally feasible to analyze even large-scale networks. However, in this paper we focus on the qualitative effects of including the physical properties of natural gas flows, and illustrate the effects in a small network example with two production nodes, two market nodes and a single transportation node.

Some examples of existing models with focus on flow maximization and natural gas transportation physics are Ehrhardt & Steinbach (2004, 2005), Martin et al. (2006), Westphalen (2004) and De Wolf & Smeers (2000). A recent PhD thesis on the linearization of natural gas flows is Van der Hoeven (2004). In An et al. (2003) a non-linear model for optimization of the combined natural gas and electricity power flow is presented. The linearization that we use in our modeling framework is based on Rømo et al. (2004).

When it comes to papers with focus on the economics of natural gas transportation, the studies we have found have a straightforward representation of gas flows, without considering the special physical properties of the network flows. Some examples are for instance Cremer et al. (2003) and Cremer & Laffont (2002), where the optimal allocation of resources has been discussed, and the social welfare maximizing solution is derived in a simplified setting, where flow externalities are not taken into account. In Cremer & Laffont (2002) the possibility of a participant with market power is also considered. Examples of economic equilibrium models are given in Gabriel & Smeers (2006), Gabriel et al. (2005) and Gabriel et al. (2001). These models focus mainly on the economic issues and do not give a detailed description of the engineering aspects underlying transportation networks.

In the electricity sector on the other hand, the effects on the physical power flows are typically taken into account when allocating capacity and dispatching units. Due to Kirchhoffs' laws in meshed electricity networks, there are severe externalities that complicate the pricing procedures. Combining the physics and the economics in models and analysis has for years been the standard way of analyzing electricity transportation and markets. A key ingredient of an electricity market design is the management of congestion or bottlenecks in the transmission network through locational prices or similar measures. Schweppe et al. (1988) formulated the optimal economic dispatch problem for electricity markets, and introduced the concept of optimal nodal prices. Chao & Peck (1996) present a consistent system of flow gate prices, and Hogan (1993) describes a hedging system for locational prices, through transmission congestion contracts. In Wu et al.

(1996), some effects of the externalities in electricity networks are investigated. Common assertions about general network performance and characteristics are scrutinized, and in some cases, counter examples are given. A thorough discussion of the interaction between the transmission network and the energy markets is given in Bjørndal (2000).

Developments during the last ten years have made it more important than ever to better understand the integration of technology and economics in the natural gas markets. In Europe, the European Commission passed the gas directive in 1998 (European Union 1998, European Commission & Transport 2002), followed by a second gas directive in 2003 (European Union 2003). The key components of the gas directive are third party access to all transportation installations, division of activities within the firms' value chain, i.e., vertical separation, and the possibility for certain consumers to obtain their gas from the supplier of their choice. A consequence of the gas market liberalization is that we may expect to see less emphasis on long-term sales contracts, emerging short-term contract markets, and more spot sales. Thus, central coordination of production and infrastructure utilization may be replaced by market prices as the coordinating mechanism. In order to achieve an efficient market, it is vital that the prices provide the correct signals of the value of the commodity to the market participants.

The purpose of this paper is to provide a framework for modeling natural gas markets that will enable future analysis to capture the technical as well as economic issues, in the same manner as the models we have seen for the liberalized electricity markets. We apply a linearized model for the technology, while the economic models may lead to non-linearities in the objective functions. In Section 2, we describe network flow models for natural gas pipelines, showing both a non-linear model, using the Weymouth equation, and a linearized approximation of it. In Section 3, network externalities are discussed under the traditional objective function, maximizing flow or throughput. In Section 4, the analysis is extended to alternative objective functions, maximizing social surplus, producer surplus or consumer surplus. For this, we utilize price responsive supply and demand curves. In Section 5, two numerical examples are given to illustrate the discussion in Section 4. Some final conclusions are provided in Section 6.

## **3.2 Natural gas flows**

In our presentation, we will use production nodes, transportation nodes and market nodes, as well as pipelines, to describe a natural gas system. The transportation system for natural gas in the North Sea is chosen as a motivating case for our work. It is the largest existing offshore network, and consists of long pipelines, where the modeling of pressure drops along the pipelines is important. For simplicity, we assume that there is one production field in each production

node. In the production nodes, we also assume that there are compressors. Thus, from these nodes, gas may be sent into the system at a pressure level that can be chosen within certain limits, depending on the compressor unit characteristics and pipeline design.

Natural gas is a mix of different hydrocarbons and other gas components like ethane, methane, butane, carbon dioxide and several others. The gas quality in terms of its chemical composition and energy content will vary from production field to production field. In our approach, we will not model the natural gas components, but rather assume that all the gas in the system is equal and may be viewed as one commodity. Our discussion will not be influenced by this assumption, but in reality modeling gas components may introduce even more externalities into the system.

Usually, several pipelines meet at transportation nodes in the network. The natural gas is mixed, and a homogeneous gas leaves the transportation node through one or several other pipelines. We will assume that it is not possible to increase pressure in the transportation nodes, i.e., there are no compressors available in the transportation nodes. This reflects the present system of the North Sea, where transportation nodes usually lack compressors due to the high installation and maintenance cost of such sub-sea installations.

In the market nodes, where the gas is traded, we have only incoming pipelines. Also in the market nodes, there may be limitations on pressure levels, for instance due to contractual agreements, which typically take the form of minimum and maximum pressure requirements.

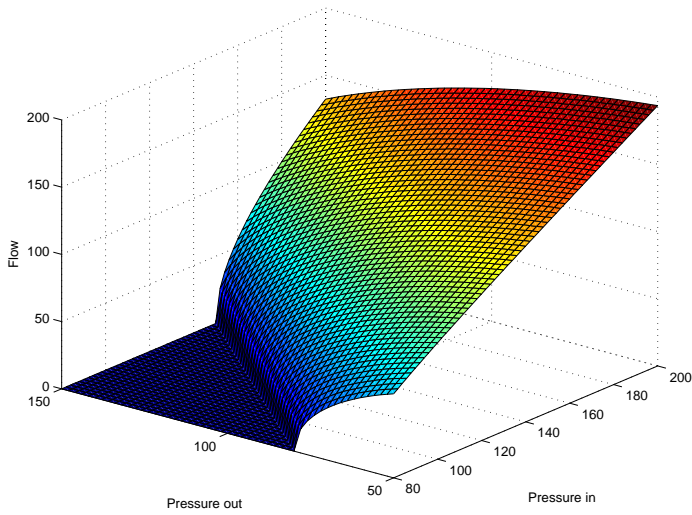
In the natural gas flow model we present here, we will first show how to model pressure and flow in a single pipeline, thereafter; we will discuss the system effects of pressure, and then give a full mathematical model.

## Flow in a single pipeline

### The Weymouth Equation

We model the pressure drops in pipelines based on the Weymouth equation, which describes the relationship between inlet pressure, outlet pressure and the amount of gas flowing in a pipeline. The flow through the pipeline is driven by the pressure difference between the inlet and the outlet of the pipeline, and the larger the difference, the more gas molecules will flow between the two points in a given period of time (see illustration in Figure 3.1). The Weymouth equation is given by:

$$Q = \frac{T\pi}{8P} 1,44 \times 10^{-3} \left( \frac{(r_i^2 - r_j^2) d^5 R}{MT_s Z L F} \right)^{0.5} \quad (3.1)$$



**Figure 3.1:** A three-dimensional illustration of how the Weymouth equation relates pressure at the inlet and outlet points to the capacity in the pipeline.

For details on this empirical equation, see for example Campbell (1992). The volume of natural gas is given in standard cubic meters ( $Sm^3$ ). The standard cubic meter refers to one cubic meter of gas under normal conditions, where normal conditions are defined to be 1 atmospheric pressure (1.01325 bar) and 15°C. The parameters and variables in Equation (3.1) have the following interpretations:

$Q$	The throughput (or flow rate), [ $MSm^3/day$ ],
$r_i$	Inlet pressure in the pipeline, [ $bar$ ],
$r_j$	Outlet pressure in the pipeline, [ $bar$ ],
$d$	The pipeline diameter, [ $m$ ],
$L$	The pipeline length, [ $m$ ],
$M$	The molecular weight of the gas, [ $kg/kmol$ ],
$T_S$	The ambient temperature of gas, [ $K$ ],
$T$	The temperature at standard conditions, [ $K$ ],
$P$	The pressure at standard conditions, [ $bar$ ],
$R$	The gas constant, [ $J/(kmol \times K)$ ],
$Z$	The average compressibility factor of the gas,
$F$	The friction factor of the pipeline.

We often aggregate the constants of the Weymouth equation into a Weymouth constant  $K_{ij}^W$  for the pipeline going from network node  $i$  to node  $j$ . The Weymouth equation can then be expressed as in Equation (3.2), where  $W_{ij}(r_i, r_j)$  is the flow through a pipeline going from node  $i$  to node  $j$  as a consequence of the pressures  $r_i$  and  $r_j$ :

$$W_{ij}(r_i, r_j) = K_{ij}^W \sqrt{r_i^2 - r_j^2}. \quad (3.2)$$

If there are limitations on the pressure level in the nodes, the flow through the pipeline will be constrained by these limits, since the flow must be less than or equal to the flow that may be obtained if the inlet pressure is at maximum level,  $\bar{R}_i$ , and the outlet pressure is at minimum level,  $\underline{R}_j$ . Consequently,

$$W_{ij}(r_i, r_j) \leq K_{ij}^W \sqrt{\bar{R}_i^2 - \underline{R}_j^2}. \quad (3.3)$$

There may be other capacity constraints limiting flow, due to for instance pipeline design parameters or capacity limitations in nodes. However, in this paper, we focus on capacity constraints following from restrictions on pressure levels only.

### Linearization of the Weymouth Equation

Through Taylor series expansion it is possible to linearize Equation (3.2) around a point  $(RI_i, RO_j)$ , representing fixed pressures into and out of the pipeline:

$$W_{ij}(r_i, r_j) \leq W_{ij}(RI_i, RO_j) + \frac{\partial W_{ij}}{\partial r_i}(r_i - RI_i) + \frac{\partial W_{ij}}{\partial r_j}(r_j - RO_j).$$

After some calculations, the Taylor expansion around  $(RI_i, RO_j)$  will take the following form for a pipeline between nodes  $i$  and  $j$  (for a detailed description, see Appendix A):

$$f_{ij} \leq K_{ij}^W \frac{RI_i}{\sqrt{RI_i^2 - RO_j^2}} r_i - K_{ij}^W \frac{RO_j}{\sqrt{RI_i^2 - RO_j^2}} r_j, \quad (3.4)$$

where  $f_{ij}$  is the flow variable. When we use the linearization to compute flow for each pipeline, around 20 of these constraints are added to the problem, representing different pairs of  $RI_{ij}$  and  $RO_{ij}$  (where  $RI_{ij}$  is larger than  $RO_{ij}$ ).

## Network flows and system effects

In a natural gas network, the practical capacities that can be utilized in one part of the network depend on the pressures and flows elsewhere in the system. For a node with more than one pipeline connected, the chosen pressure level in the node influences the capacity in all pipelines connected to the node. There are two alternative ways of modeling the system effects of pressure.

First, we can choose to model the situation, where in a network node, the outlet pressure in all incoming pipelines and inlet pressure of all outgoing arcs, are equal. Under this assumption, the Weymouth equation must be modeled as an equality, as presented in its original non-linear form in Equation (3.1). The linearization in Equation (3.4) is not valid, as modeling flow using an inequality in this constraint, basically corresponds to allowing a pressure drop at the inlet of the pipelines.

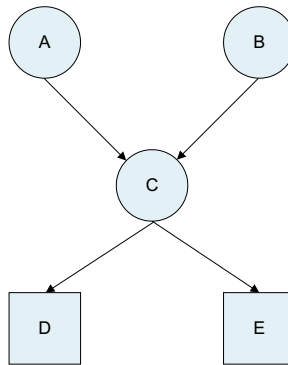
Alternatively, we can model a more advanced node with valve arrangements, that makes it possible to reduce the inlet pressure in some of the outgoing pipelines. In practice, this corresponds to modeling the pipeline capacity as an inequality, allowing the flow in the pipeline to be lower than the flow following from a given node pressure. In this case, the linearization in Equation (3.4) may be used.

The linearized variant is used in models developed for the system operator in the North Sea for analyzing network flow. The main reason is that it better reflects the typical situation of many real transportation networks, including the one in the North Sea. Another reason is that the formulation using Equation (3.1) leads to a non-convex problem, limiting the size of problems that may be analyzed. One should note that the externalities due to system effects, that we will

describe in the following sections, will be present also in the first case, when an equality is used in Equation (3.1), as it gives an even stronger link between the different pipeline flows.

In the following, we will illustrate the system effects of pressure with the example network in Figure 3.2. There are two production nodes ( $A$  and  $B$ ), two market nodes ( $D$  and  $E$ ) and a transportation node ( $C$ ). The maximum pressure in production node  $A$  is assumed to be larger than in production node  $B$ . Assuming similar design parameters and similar lengths for the two pipelines  $AC$  and  $BC$ , this gives the pipeline from  $A$  to  $C$  larger capacity than the pipeline going from  $B$  to  $C$ . In this example, we will assume that any pressure limits in node  $C$  are not restrictive. There are also minimum pressure requirements in the market nodes  $D$  and  $E$ . Since the minimum pressure in node  $E$  is assumed to be lower than the corresponding figure for node  $D$ , the capacity of pipeline  $CE$  is larger than the capacity of  $CD$ , assuming the two pipelines are otherwise equal. The pipeline flows depend on the Weymouth constants of the corresponding pipelines, and the pressure differences along the pipelines, as given by the Weymouth equation.

The relationship between the pressure levels in the pipeline system is illustrated in Figure 3.3. The  $x$ -axis represents the location of the nodes, while the  $y$ -axis represents the pressure. Maximum and minimum pressure requirements in the nodes are given by horizontal lines in the figure. The downward sloping lines connecting two nodes represent a pipeline and show the inlet and outlet pressures and the pressure drop along the pipeline. To increase the flow in a pipeline, either the outlet pressure needs to be reduced, or the inlet pressure must increase, or in other words, the absolute value of the slope of the corresponding line in the figure must increase.



**Figure 3.2:** Example of a transportation network consisting of two production nodes, a transportation node and two market nodes.



In the upper part of Figure 3.3, we have assumed that the pressure in node  $B$  is at the upper limit, while it is still possible to increase the pressure in node  $A$ . Moreover, the pressure in node  $E$  is at the lower limit.

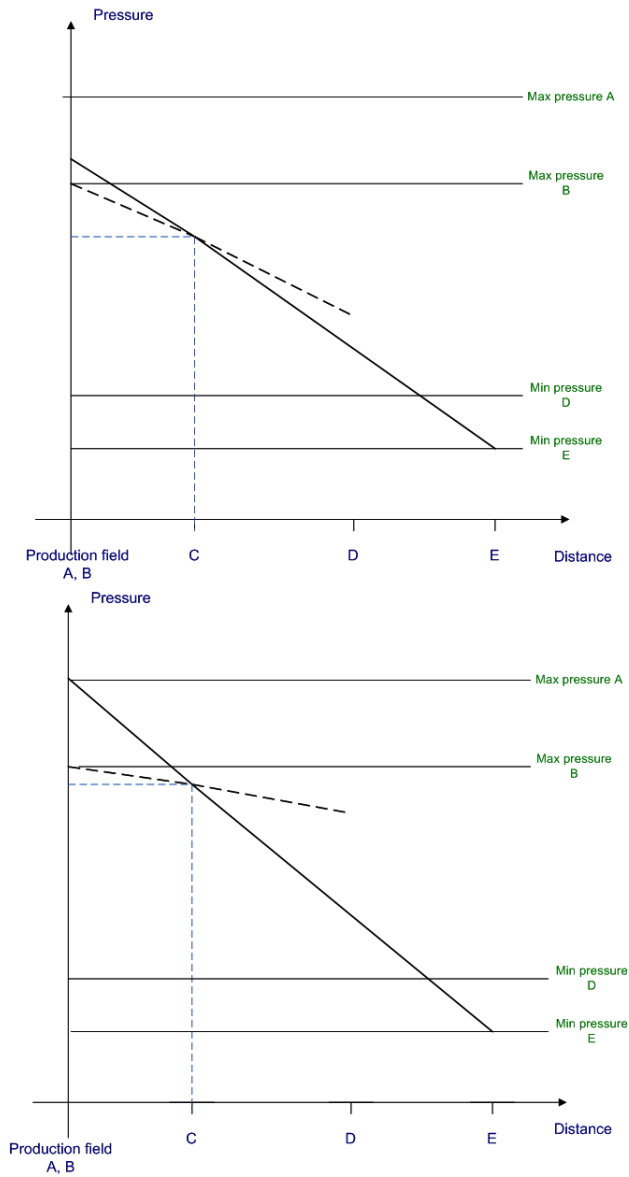
Consider now a situation where production field  $A$  is offered a new contract for delivery to market  $E$ . To accommodate this increase in flow from  $A$  to  $E$ , the pressure in node  $A$  must be increased relative to the pressure in node  $C$ . Besides, the pressure difference between node  $C$  and  $E$  must increase in order to increase the flow through this pipeline. Since the pressure in node  $E$  is at its lower limit, in practice, this means that the pressure in node  $C$  has to be increased, and since there are no compressors in node  $C$ , it means that pressure must increase in the production field to accommodate this. The new situation is shown in the lower part of Figure 3.3. More gas flows from  $A$  to  $E$  (the line joining  $A$  and  $E$  has become steeper), but less gas now flows from  $B$  to  $D$  (the line joining  $B$  and  $D$  is flatter) because of the higher pressure in node  $C$ , and the fact that pressure in node  $B$  cannot increase. In the new situation, more capacity is available from node  $C$  to the markets, but less capacity is available from the production nodes to node  $C$ . The available transportation capacity from node  $B$  has been reduced as a consequence of the increased transportation from node  $A$ . The fact that there are no compressors to increase pressure in the transportation node, introduce externalities, and there is a trade-off between the capacity of the upper pipelines (before the transportation node) and lower pipelines (after the transportation node).

## A natural gas network model

In the following, we present a linear programming model for physical flow maximization in the transportation network, based on work at SINTEF and NTNU Rømo et al. (2006), and in Section 3.4 we will extend this model to include economic objectives.

### Sets

- $\mathcal{N}$  The set of all nodes in the network.
- $\mathcal{G}$  The set of nodes in the network with production fields.
- $\mathcal{M}$  The set of market nodes.
- $\mathcal{T}$  The set of transportation nodes.
- $\mathcal{I}(n)$  The set of nodes with pipelines going into node  $n$ .
- $\mathcal{O}(n)$  The set of nodes with pipelines coming from node  $n$ .



**Figure 3.3:** The top figure shows the original state of the network, while the lower figure shows the state of the network after the flow from  $A$  to  $E$  is increased.

**Constants**

- $\bar{R}_i$  Max pressure [bar] in node  $i \in \mathcal{N}$ .
- $\underline{R}_i$  Min pressure [bar] in node  $i \in \mathcal{N}$ .

**Decision variables**

- $k_g$  Production in field  $g \in \mathcal{G}$ .
- $f_{ij}$  Flow from node  $i \in \mathcal{N}$  to node  $j \in \mathcal{O}(i)$ .
- $r_i$  Pressure [bar] in node  $i$ .
- $q_m$  Volume of natural gas in market  $m \in \mathcal{M}$ .
- $p_m^d$  Price of natural gas in market  $m \in \mathcal{M}$ .
- $p_g^s$  Price of natural gas in production node  $g \in \mathcal{G}$ .

**Objective function**

The mathematical formulation for maximizing flow is straightforward:

$$\max \sum_{i \in \mathcal{I}(m)} \sum_{m \in \mathcal{M}} f_{im}, \tag{3.5}$$

where  $f_{im}$  is the flow from node  $i$  to market node  $m$ ,  $\mathcal{M}$  is the set of all market nodes and  $\mathcal{I}(m)$  is the set of all nodes with pipelines going into  $m$ .

**Constraints**

The first set of constraints ensures that mass is conserved in the network. Production  $k_g$  in node  $g \in \mathcal{G}$  must equal the amount of gas  $f_{gj}$  transported from the production node  $g$  into nodes  $j$  in its set of downstream nodes  $\mathcal{O}(g)$  :

$$\sum_{j \in \mathcal{O}(g)} f_{gj} = k_g, \quad g \in \mathcal{G}. \tag{3.6}$$

For the transportation nodes, the amount of gas that flows into node  $j$  must also flow out of node  $j$ :

$$\sum_{i \in \mathcal{I}(j)} f_{ij} = \sum_{n \in \mathcal{O}(j)} f_{jn}, \quad j \in \mathcal{T}. \tag{3.7}$$

In the market node  $m$  we need to make sure that the quantity of gas available in the market,  $q_m$ , is equal to the sum of the gas flowing into the market:

$$\sum_{j \in \mathcal{I}(m)} f_{jm} = q_m, \quad m \in \mathcal{M}. \quad (3.8)$$

Moreover, we need to make sure that the maximum and minimum requirements for the pressure in the nodes are satisfied:

$$r_i \geq \underline{R}_i, \quad i \in \mathcal{N}. \quad (3.9)$$

$$r_i \leq \overline{R}_i, \quad i \in \mathcal{N}. \quad (3.10)$$

We will present two alternatives for modeling pipeline capacity constraints due to pressure limitations. The first is the one that we advocate, where pressure and system effects are modeled properly, based on the Weymouth equation. The linear constraint in (3.4) corresponds to an outer linearization of the Weymouth equation for the pipeline flow. A more precise approximation is obtained by using a set of linearizations around the pairs of inlet and outlet pressures  $(RI_l, RO_l), l = 1, \dots, L$ , for each pipeline. We denote this constraint set the Weymouth formulation (WF). The second alternative is the formulation usually found in economic models of gas systems, like Cremer et al. (2003) and Cremer & Laffont (2002), which we will denote Independent Static Flow constraints (ISF). When we discuss the economic modeling of gas networks, we will compare the ISF formulation with the WF formulation that we suggest should be used.

The Weymouth formulation is given by:

$$f_{ij} \leq K_{ij}^W \frac{RI_{il}}{\sqrt{RI_{il}^2 - RO_{jl}^2}} r_i - K_{ij}^W \frac{RO_{jl}}{\sqrt{RI_{il}^2 - RO_{jl}^2}} r_j, \quad (3.11)$$

$$i \in \mathcal{N}, j \in \mathcal{O}(i), l = 1, \dots, L,$$

where we use  $L$  linear constraints for each pipeline. The system effects of pressure are implicitly modeled by the nodal pressure variables. If the pressure in a node must be uniform for all connected pipelines, the inlet pressure of a pipeline out of transportation node  $n$  is equal to the outlet pressure in a pipeline going into the node. Thus, the capacity of the pipelines connected to the node is dependent on the nodal pressure, and therefore also dependent on one another. With the linearization of the Weymouth equation, the nodal pressure formulation ensures that pressure is not built up at nodes without compressors, but allows for pressure drops, thus reducing flow in a given pipeline relative to its pressure potential. Still, pressure levels in one part of the network will depend on the chosen pressure values in other parts of the network.

The alternative model for pipeline capacities, is the ISF-formulation,

$$f_{ij} \leq C_{ij}, \quad i \in \mathcal{N}, j \in \mathcal{O}(i), \quad (3.12)$$

where  $C_{ij}$  is the static flow-independent capacity for the pipeline connecting nodes  $i$  and  $j$ . Note that in this case, the system effects disappear from the model, as the flow capacity of one pipeline is not influenced by other pipelines' flows. When replacing the Weymouth constraints with ISF constraints, it is an open question how to determine pipeline capacities. One possibility is to use the maximum pressure difference for the pipeline to determine its static capacity:

$$C_{ij} = K_{ij}^W \sqrt{R_i^2 - R_j^2}. \quad (3.13)$$

In this case, the system effect is not properly modeled, and the capacity is set at its best possible value, which can be achieved in theory, but not necessarily in practice. In the next section, we will illustrate the difference in two numerical examples.

### 3.3 Max flow and network externalities - two numerical examples

In this section, we present two examples that illustrate the importance of including pressure drops in the modeling of natural gas flows. Network externalities are present both in operational max flow problems and in long-term investment problems. In Section 3.4 we extend the analysis to situations with alternative economic objectives.

#### Example 1: Externalities from network operations

Returning to the example network in Figure 3.2, Section 3.2, let us investigate how an increase in flow from node  $A$  to node  $E$  can influence the total throughput. We analyze the network using pressure constraints and pressure drops and compare it to an approach with ISF capacities.

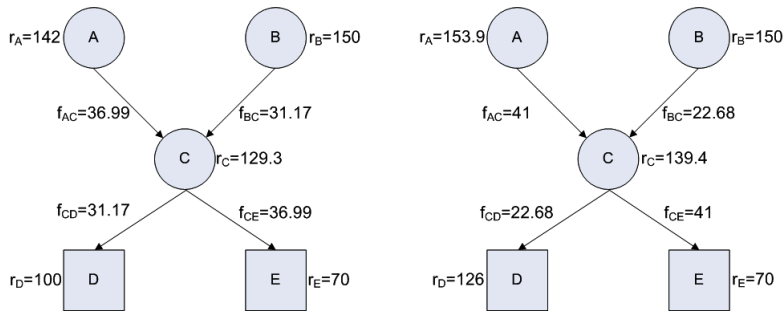
The design parameters in Table 3.1 will be used. The pressure constraints of the pipelines are due to the design parameters in the network, as well as compressor capacities at the production nodes, and specifications in the delivery contracts. The Weymouth constants are chosen such that they resemble pipelines in real installations in the North Sea. Maximization of throughput in this system, gives a flow from  $A$  to  $E$  of  $36.99 \text{ MSm}^3/d$ , and  $31.17 \text{ MSm}^3/d$  from  $B$  to  $D$ , i.e., a total flow to the market nodes of  $68.16 \text{ MSm}^3/d$ .

Now, consider a situation where the producer in node  $A$  wants to deliver  $41 \text{ MSm}^3/d$  to the market in node  $E$ . How will this influence the flow from

	A to C	B to C	C to D	C to E
Max pressure into pipeline, [bar]	200	150	140	140
Min pressure out of pipeline, [bar]	120	120	100	70
Weymouth-constant	0,63	0,41	0,38	0,34

**Table 3.1:** Design parameters

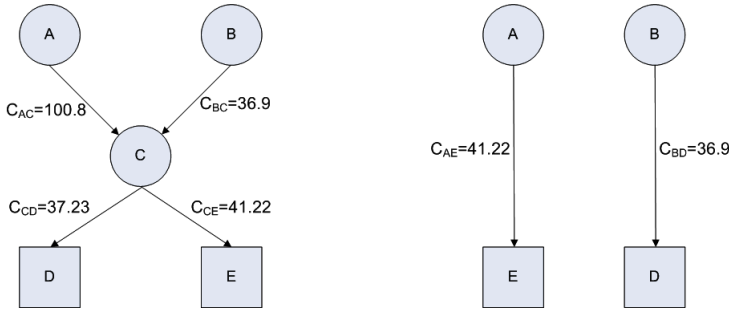
B to D? Imposing this new constraint and maximizing throughput using the model from Section 3.2 gives the following result: flow from A to E is, as desired, 41  $MSm^3/d$ , while the flow from B to D is reduced to 22.68  $MSm^3/d$ . Thus, when the flow from A to E increases by 4  $MSm^3/d$ , the flow from B to D is reduced by more than 8  $MSm^3/d$ . The pressure in node C has increased from 129 bar to 139 bar, and this change has decreased the transportation capacity from the production nodes to node C. The results are illustrated in Figure 3.4. It is evident that the relationship between flows in the network is far from linear, and that rather small changes in one part of the network can have a large influence on other parts.



**Figure 3.4:** Example of a transportation network consisting of two production nodes, a transportation node and two market nodes. The figure to the left gives the original solution, and the figure to the right the flow when the flow from A to E is increased.

Using Equation (3.13) to compute ISF capacity constraints on the pipeline flows, based on specified max and min pressures, gives the following flow constraints:  $C_{AC} = 100.8 MSm^3/d$ ,  $C_{BC} = 36.9 MSm^3/d$ ,  $C_{CD} = 37.23 MSm^3/d$ , and  $C_{CE} = 41.22 MSm^3/d$ . The maximal throughput is then equal to  $\min(100.8 + 36.9, 37.23 + 41.22) MSm^3/d = 78.45 MSm^3/d$ , while if we consider the contractual paths, assuming production node A trades with market E and production node B with D, the capacities for trades are  $C_{AE} = \min(100.8, 41.22) MSm^3/d$

and  $C_{BD} = \min(36.9, 37.22) \text{ MSm}^3/d$ . The capacities are illustrated in Figure 3.5.



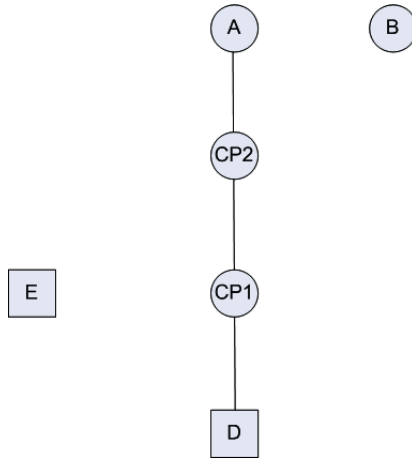
**Figure 3.5:** The figure on the left shows the pipeline network with ISF constraints. The figure on the right shows the ISF capacities of contract paths.

Using any of these capacities either fails to recognize the dependency of flows completely (the contractual capacities), or exhibit a linear relationship between flows, where, for instance, reducing flow from node  $A$  to any of the market nodes by one unit, makes it possible to increase the flow from node  $B$  by one unit. Another issue is that the ISF constraints calculated from Equation (3.13), based on maximum and minimum pressure limits, grossly overestimates the practical capacities of the pipeline network, with a max flow of  $78.45 \text{ MSm}^3/d$  as compared to the  $68.16 \text{ MSm}^3/d$  if pressure levels and limits are taken into account.

## Example 2: Externalities and investment decisions

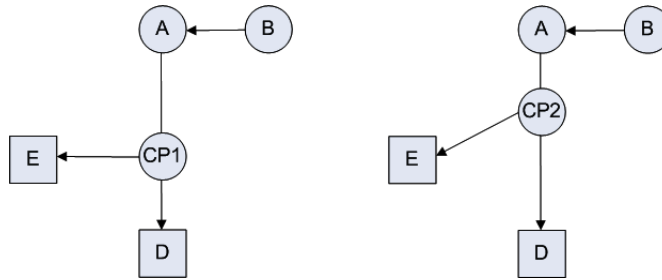
Understanding the physics of the network system is important in order to make good infrastructure and capacity decisions. In the following, we show an example of network externalities due to investment decisions. Assume that we have a simple basis network to start with, consisting of production node  $A$ , market node  $D$  and two intermediate nodes  $CP1$  and  $CP2$ . The network is illustrated in Figure 3.6.

A single producer in node  $A$  is transporting gas to the market node  $D$  through a single pipeline. However, a small field is under development (node  $B$ ). The field in node  $B$  will deliver its production to a new market in node  $E$ . Instead of building a new pipeline going from  $B$  to  $E$ , the nodes can be connected to the existing pipeline from  $A$  to  $D$ . By using the pipeline from  $A$  to  $D$ , the additional pipelines are shorter than if a completely new pipeline should cover the whole distance. Assume that the pipeline going to market node  $E$  can be connected at



**Figure 3.6:** The original network with the two potential junction points.

one of two intermediate positions on the existing pipeline from  $A$  to  $D$ :  $CP1$  or  $CP2$ . The investment possibilities are illustrated in Figure 3.7. This is a typical realistic investment situation on the Norwegian continental shelf.



**Figure 3.7:** Two different junction points.

Assuming that  $A$  is responsible for delivering to node  $D$  and that  $B$  is responsible for the volume going to node  $E$ , we solve the max flow problems for the two cases using the model in Section 3.2. The design parameters are given in Table 3.2, and we assume that the pipeline from  $B$  to  $A$  is not a bottleneck in the system, and does not influence the pressure at node  $A$ .

With these values, the flow capacity of the pipeline between  $A$  and  $D$  is  $51.3 \text{ MSm}^3/d$ , before any investments are done. After investment, the two alternative junction points lead to different transportation capacities between  $A$



Max pressure into pipeline from $A$	160 bar
Min pressure out of pipeline into $D$	80 bar
Min pressure out of pipeline into $E$	70 bar
Weymouth-constant from $A$ to $D$	0.37
Weymouth-constant from $A$ to $CP1$	0.44
Weymouth-constant from $A$ to $CP2$	0.62
Weymouth-constant from $CP1$ to $D$	0.69
Weymouth-constant from $CP1$ to $E$	0.62
Weymouth-constant from $CP2$ to $D$	0.46
Weymouth-constant from $CP2$ to $E$	0.52

**Table 3.2:** Design parameters

and  $D$ . We assume in both cases that the volume between  $B$  and  $E$  is fixed to  $10 \text{ MSm}^3/d$ , and then maximize the throughput between  $A$  and  $D$ . The result of the numerical example is illustrated in Figure 3.8. The graph on the top left hand shows the original situation with volumes and pressures. The graph on the top right hand shows the solution if  $CP1$  is chosen, and the one underneath is the solution when using  $CP2$  as a junction point. With  $CP1$ , the capacity  $C_{AD}$  is  $44.1 \text{ MSm}^3/d$ , and with  $CP2$ , the capacity is  $47.5 \text{ MSm}^3/d$ . The reduction in capacity between  $A$  and  $D$  is  $7.2 \text{ MSm}^3/d$  and  $3.8 \text{ MSm}^3/d$  respectively, so there is a daily difference of  $3.4 \text{ MSm}^3/d$  between the two alternatives.

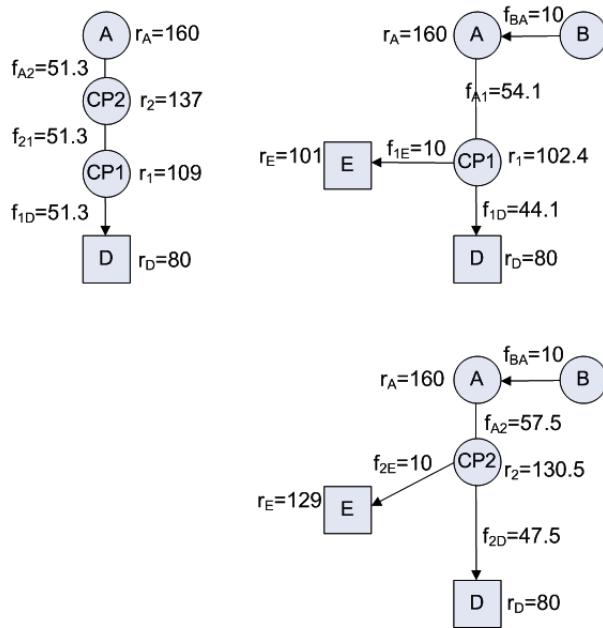
Comparing the solution for the extended network with the original network, we see that the pressures in the nodes  $CP1$  and  $CP2$  have decreased. This decrease is due to the need for higher delivery between  $A$  and the junction point. Since the pressure in node  $A$  was at the maximum level in the original solution, this increase can only be obtained by reducing the pressure in the junction points. The difference in the solutions for the two alternative junction points, can be explained by looking at the Weymouth equation: when the length of the pipeline is increased, the Weymouth constant decreases (see Equation (3.1)), and therefore, less gas is transported for a given pressure difference<sup>1</sup>.

Another aspect to take into consideration is the investment cost of the new pipelines. In the alternatives presented here, the pipeline from  $CP2$  to  $E$  is approximately 40 % longer than the pipeline from  $CP1$  to  $E$ .

If the pressure constraints had not been included in the model, the location of the junction point would not have influenced the capacity between  $A$  and  $D$ . The

---

<sup>1</sup>The lengths used in this example is 840 km between  $A$  and  $D$ , 600 km from  $A$  to  $CP1$ , 240 km from  $CP1$  to  $D$  and 300 km to  $E$ , 300 km from  $A$  to  $CP2$ , 540 km from  $CP2$  to  $D$  and 424 km to  $E$ . The Weymouth-constant is dependent on the square of the length of the pipeline (see Equation (3.1)), and therefore the difference between the constants may be non-intuitive.



**Figure 3.8:** Flow and pressure values for the original network and for the two investment possibilities.

example shows that there are several considerations that need to be accounted for when we are looking at expanding a natural gas network. The owners of field  $A$  must be compensated somehow for the loss of capacity after the new investments. Moreover, there is a trade-off between the additional investment costs of building a longer pipeline and the possibility to get more capacity in the network. The optimal solution will depend on several factors, such as investment costs, ownership in the fields and in the network, regulation of the network and market conditions (supply and demand).

### 3.4 Optimal dispatch with economic objective functions

Incorporating pressure constraints and pressure drops when modeling natural gas flows, will influence the solutions also when using different economic objective functions. From the max flow examples, we saw that the externalities in natural gas flows influence the practical capacities of the pipeline networks. By introducing economic objectives, we will investigate the validity of economic reasoning based on simple ISF constraints as opposed to the more detailed modeling of the network in our approach.

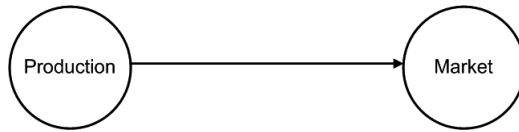
In the following, we assume that there exist supply functions in the field nodes and demand functions in the market nodes, representing marginal production cost and marginal benefits from consumption, respectively. We focus on the short-term optimal operation of the natural gas system, given the existing infrastructure, with production, transportation and market nodes, pipelines, and compressors with predetermined properties. We will assume that all the relevant short-term costs are reflected in the supply functions. This is a simplification, as there may be some flow dependent and pressure dependent costs associated with for instance using gas for building up pressure. Flow dependent or pressure dependent costs could be taken into account by adding corresponding cost terms in the objective function, however, as we want to focus on the effect of the capacity constraints following from pressure limitations, we have not considered these cost terms. Our approach follows along the same lines as the analyses of congestion in electricity markets, where congestion management is frequently studied assuming lossless approximations of power flows.

We start by defining different economic objectives, before we summarize well-known results for the single pipeline case, and finally move on to our contribution in the analysis of economic objectives in a pipeline system. We consider the maximization of the following objectives: social surplus, consumer surplus and producer surplus. In our presentation, we use linear demand and supply functions. With the linearized Weymouth equations to model pipeline flows, the

resulting optimization problems are quadratic optimization problems with linear constraints.

### Economic dispatch in a single pipeline

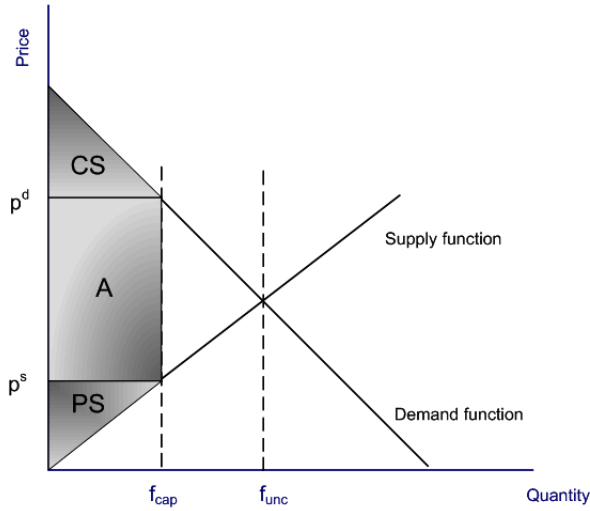
Consider the situation in Figure 3.9, with a system consisting of a production node, a market node, and a single pipeline connecting the two nodes. The transportation capacity is restricted by the design parameters of the pipeline. Clearly, in this case, there is no pipeline system to interact with, so an ISF constraint for the pipeline flow, such as Equation (3.13), is sufficient to represent the maximum amount of gas possible to transport. Overviews of existing theory for analyzing single transportation links with capacity constraints exist, for example in Tirole (1988). For completeness, we give a short introduction here (for more details, see also Appendix 3.B)).



**Figure 3.9:** Example of a transportation network consisting of a single pipeline.

With a congested pipeline with capacity  $f_{cap} < f_{unc}$ , as in Figure 3.10, maximizing social surplus corresponds to maximizing the trapezoid limited by the supply function, the demand function and the capacity constraint, i.e., the sum of the areas  $CS$ ,  $PS$  and  $A$ . We call this solution the constrained optimal economic dispatch. At quantity  $f_{cap}$  the two nodes will have different marginal values, and one possibility is that a system operator can bring along the equilibrium by giving the producer a price of  $p^s$  and charging a price of  $p^d$  from the market. The income to the system operator would then be equal to the area  $A$  in Figure 3.10. Note that there may be other ways to implement the optimal solution, for instance by managing capacity limitations through redispatching in secondary markets, or through various two-part tariffs. These different alternatives for dealing with transmission constraints will typically result in different allocations of total surplus between suppliers, consumers and a possible system operator. We will not discuss these issues further in this paper, however, independent of how capacity constraints are managed, in the optimal solution, maximizing social surplus, the marginal values should be consistent with the prices  $p^s$  and  $p^d$ .

In the unconstrained solution, maximizing social surplus gives an optimal gas flow,  $f^*$ , equal to  $f_{unc}$ . When maximizing producer or consumer surplus, the optimal unconstrained quantity  $f^*$  is usually less than  $f_{unc}$  (refer Appendix 3.B). Since the optimization problems have concave objective functions and convex



**Figure 3.10:** Situation when pipeline capacity is restricting the solution.

feasible regions, the pipeline will be used to the capacity limit in the constrained cases where  $f_{cap} < f^*$ , i.e., the optimal quantity produced and transported over the pipeline is equal to  $\min(f_{cap}, f^*)$ . This means that for sufficiently constrained networks, the optimal solution will be identical and equal to  $f_{cap}$  for all three objective function alternatives. For details on the single pipeline optimization see Appendix 3.B. In the following, we will assume that when maximizing either consumer surplus or producer surplus, the consumer or producer respectively, will take all the profit in area  $A$ . This means that maximizing consumer surplus is done by maximizing the area  $CS + A$ . Likewise, maximizing producer surplus is the same as maximizing the area  $PS + A$ . An interpretation of this assumption is that when maximizing consumer or producer surplus, we assume either the consumer or production side to be in control of the pipeline system, and the network operator function.

### Economic dispatch in a pipeline system

In this section we formulate the optimal economic dispatch in a network of pipelines, with several production and market nodes. We focus on the difference between using the modeling framework described in Section 3.2 as opposed to applying ISF capacities throughout the network.

Supply and demand functions for the production and market nodes are assumed

to be deterministic and linear. Thus, the demand function in market node  $m \in \mathcal{M}$  is given by:

$$p_m^d = \alpha_m^d - \beta_m^d q_m, \quad (3.14)$$

where  $p_m^d$  is the price, depending on volume  $q_m$ , and  $\alpha_m^d$  and  $\beta_m^d$  are positive constants. For simplicity, we assume that the supply functions go through the origin, such that supply in production node  $g \in \mathcal{G}$  is given by:

$$p_g^s = \beta_g^s k_g, \quad (3.15)$$

where  $p_g^s$  is the price in production node  $g$ ,  $k_g$  is the volume produced, and  $\beta_g^s$  is a positive constant.

The objective functions then, have the following formulations, and are generalizations of the two-node situation, which is illustrated in Figure 3.10:

- Max social surplus:

$$\max \sum_{m \in \mathcal{M}} \left( \alpha_m^d q_m - \frac{1}{2} \beta_m^d q_m^2 \right) - \sum_{g \in \mathcal{G}} \frac{1}{2} \beta_g^s k_g^2. \quad (3.16)$$

- Max consumer surplus (monopsony):

$$\max \sum_{m \in \mathcal{M}} \left( \alpha_m^d q_m - \frac{1}{2} \beta_m^d q_m^2 \right) - \sum_{g \in \mathcal{G}} \beta_g^s k_g^2, \quad (3.17)$$

- Max producer surplus (monopoly):

$$\max \sum_{m \in \mathcal{M}} (\alpha_m^d q_m - \beta_m^d q_m^2) - \sum_{g \in \mathcal{G}} \frac{1}{2} \beta_g^s k_g^2. \quad (3.18)$$

When comparing models with the Weymouth formulation to models with ISF capacities, we analyze all the different objective function variants; maximization of social surplus, consumer surplus and producer surplus. Hence, we will compare the results obtained from two classes of optimization models, using:

1. WF pressure constraints: {max (3.16) or (3.17) or (3.18) s.t. (3.6)-(3.11)}
2. ISF capacity constraints: {max (3.16) or (3.17) or (3.18) s.t. (3.6)-(3.8) and (3.13)}

## 3.5 Optimal economic dispatch - two numerical examples

In this section, we provide numerical examples illustrating the effects that pressure constraints have on optimal economic dispatch in a natural gas network. We start with a moderately constrained network that illustrates the difficulties in finding ISF capacities. Thereafter, we move on to a strongly constrained network. This example shows that even in a highly constrained network, where all objective function alternatives give the same solution with ISF constraints, the solutions are different for the alternative objectives when including WF pressure constraints. This is due to the fact that modeling pressure in a network, introduces some flexibility that is not incorporated with the ISF capacities.

### Example 3: Optimal dispatch and ISF capacities

This example illustrates how the ISF capacities introduced in Equation (3.13) overestimates the true capacity in the network. If this approach is used to model flow constraints due to pressure limits throughout a network, we obtain a relaxation of the optimal dispatch problem, where flow and flow constraints are modeled by means of the Weymouth equations. This is evident from noting that Equation (3.13) gives the highest possible flow between two nodes  $i$  and  $j$  with pressure limits  $\bar{R}_i$  and  $\underline{R}_j$ , but that Equation (3.13) fails to recognize the dependencies between pipeline pressures. In a network, it will not normally be possible to run every pipeline with maximum pressure difference between the connected nodes. If this is possible, the optimal solution is equal to the solution from the ISF capacities model, if not, the ISF formulation based on capacity constraints (3.13) is a relaxation of the true model.

In the following, consider a network with the same configuration as in Figure 3.2. The design parameters are shown in Table 3.3, while the ISF capacities are calculated from Equation (3.13) and displayed in Table 3.4.

	$A$ to $C$	$B$ to $C$	$C$ to $D$	$C$ to $E$
Maximum pressure into pipeline	160	180	150	150
Minimum pressure out of pipeline	125	125	90	75
Weymouth-constant	0.40	0.45	0.30	0.35

**Table 3.3:** Design parameters

We then use the supply and demand functions in Table 3.5 to compute the optimal dispatch under the three different objective functions. As can be seen from the flows in Figure 3.11 and the prices (or marginal values) in Table 3.11,

Capacity from $A$ to $C$	42.33
Capacity from $B$ to $C$	60.37
Capacity from $C$ to $D$	39.69
Capacity from $C$ to $E$	41.57

**Table 3.4:** ISF capacities in the network

the results depend a great deal on which model is used to represent network flows. As expected, we see that the solutions for the ISF capacities give higher total flow for all the objective functions. The objective function value is also increased for all the objective functions under the ISF capacities. However, the flow pattern given by the model with ISF constraints is naturally not necessarily feasible for the pressure constraint (WF) model.

Supply from node $A$	$p_1^s = k_1$
Supply from node $B$	$p_2^s = 3k_2$
Demand in node $D$	$p_1^d = 200 - 2q_1$
Demand in node $E$	$p_2^d = 200 - 3q_2$

**Table 3.5:** Supply and demand functions.

	Objective					
	Social surplus		Consumer surplus		Producer surplus	
	WF	ISF	WF	ISF	WF	ISF
Price in node $A$	34.6	42.3	38.7	42.3	35.5	42.3
Price in node $B$	83.7	96	54.6	62.1	54.6	54.6
Price in node $D$	140	120.6	145.8	124.4	141	127.4
Price in node $E$	102.5	96.2	110.6	124.4	127.4	127.4
Objective value	8255.21	9058.9	6820.88	7145.03	6115	6316.57

**Table 3.6:** Prices and objective function values.

It may be argued that it is unrealistic to apply the capacities from Equation (3.13) directly, but rather make some reductions to allow for the system effects of the pressure constraints. However, it is an open question how this should be accomplished, as the necessary capacity adjustments will depend on supply and demand parameters as well as the design parameters of the transportation network.



3.5 Optimal economic dispatch - two numerical examples

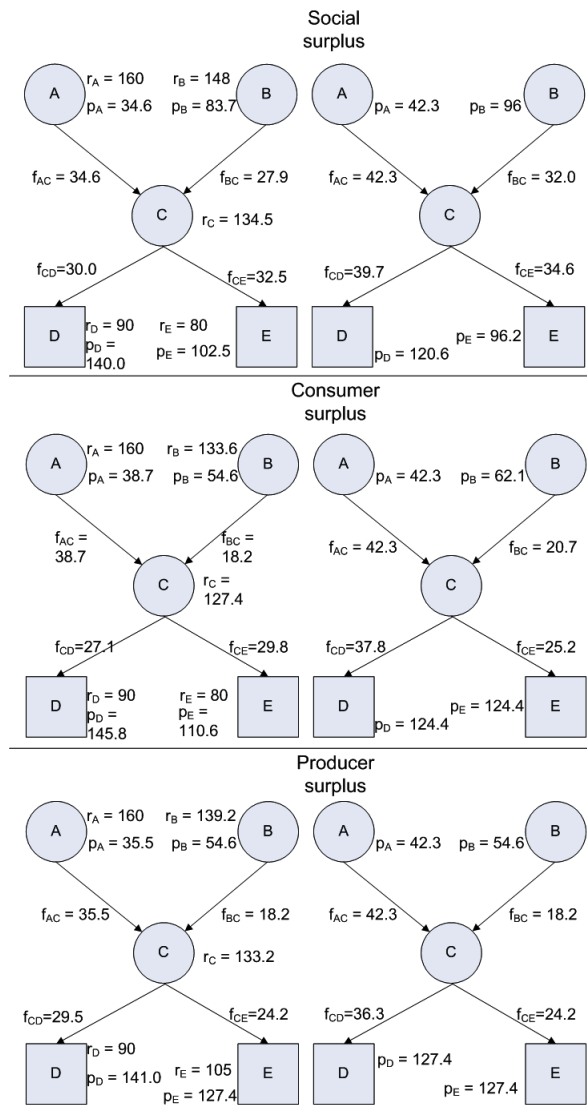


Figure 3.11: Solution with pressure constraints (on the left) and ISF constraints (on the right).

**Example 4: Optimal dispatch in a strongly constrained network**

We continue to use the example network in Figure 3.2, and the same supply and demand functions as in the previous example (see Table 3.5). First, note that in the unconstrained case, the competitive solution, maximizing social surplus, would have resulted in a price of 76.9 in every node in the network, and the total production (and consumption) would be 102.5  $MSm^3/d$ . As expected, the production is highest in node *A* while sales are highest in node *D*. The solutions maximizing consumer surplus and producer surplus both give lower production volumes. When maximizing consumer surplus, the market price is 111.1 and the total production is 74  $MSm^3/d$ . Maximizing producer surplus gives a market price of 123.8 and a total production of 63.5  $MSm^3/d$ . The size of the *CS*, *A*, and *PS* areas in Figure 3.10) are given in the ISF column in Table 3.10 and are equal independent of which objective is used ( $CS + A$ ,  $PS + A$  or  $CS + A + PS$ ).

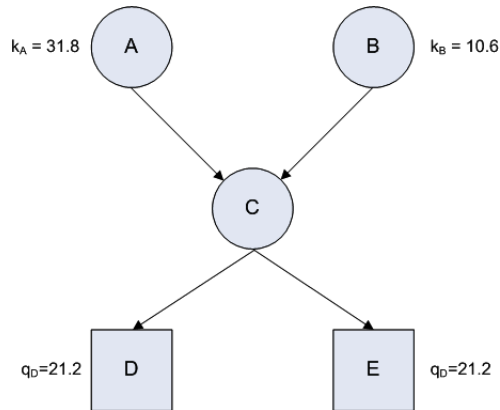
In order to analyze a strongly constrained network, we choose design parameters such that none of the flows from the unconstrained solutions are feasible. The design parameters are displayed in Table 3.7, and the ISF capacities calculated by Equation (3.13) are shown in Table 3.8.

When maximizing the three different surpluses in this constrained network, the ISF network model gives the same value for the decision variables, independent of the objective function. The resulting flow pattern is illustrated in Figure 3.12, showing the production in the field nodes and the volumes consumed in the market nodes. The identical results for the three objectives, using the ISF formulation, is similar to the single pipeline case in Section 3.4. Since the optimal unconstrained solution for every objective function is beyond the capacity of the network, the network will be used to the capacity limit, which is here equal to  $\min(39.4 + 12.7, 21.2 + 21.2) = 42.4$ .

	<i>A</i> to <i>C</i>	<i>B</i> to <i>C</i>	<i>C</i> to <i>D</i>	<i>C</i> to <i>E</i>
Maximum pressure into pipeline	172	135	135	135
Minimum pressure out of pipeline	130	130	115	115
Weymouth-constant	0.35	0.35	0.30	0.30

**Table 3.7:** Design parameters

For the network model with WF pressure constraints and pressure drops, however, the optimal flow patterns are no longer identical for the different objective functions. I.e., even in this very strongly constrained network, the dependencies between flow in different parts of the system, influence the solutions. The flow patterns are illustrated in Figure 3.13, and Table 3.10 displays the allocation of surpluses between consumers (*CS*), producers (*PS*), grid revenue (*A*) and the



**Figure 3.12:** The solution when maximizing social surplus, consumer surplus and producer surplus with ISF capacities.

Capacity from $A$ to $C$	39.4
Capacity from $B$ to $C$	12.7
Capacity from $C$ to $D$	21.2
Capacity from $C$ to $E$	21.2

**Table 3.8:** The ISF capacities.

total social surplus  $CS + A + PS$ ) for the different objective functions (see Figure 3.10). This is contrasted with the allocation of surplus in the ISF model. The total surplus in the ISF model is higher; however, this is once more due to the fact that the ISF solution is not feasible when we take into account the pressure limits and the externalities in the network.

Consider now the WF solutions. In the monopsony case, maximizing consumer surplus ( $CS + A$ ), we note that compared to the solution with maximal social surplus, some of the production has been switched from production node  $A$  to production node  $B$ . This reduces the size of the traditional consumer surplus  $CS$ , however, the resulting increase in  $A$  is larger, such that total monopsony surplus ( $CS + A$ ) increases. This result is due to two factors: the capacity constraints on the network, and the special properties of the pressure constraints. With the pressure constraints, the effective capacity of each pipeline is determined by the operation of the other pipelines in the system. This adds flexibility to the operator of the system, and gives possibilities of moving and creating bottlenecks in the system. In this example, the monopsony has decreased the pressure in node  $C$ , and therefore increased the capacity from node  $B$  to node  $C$  at the expense of the capacity from node  $C$  to nodes  $D$  and  $E$ .

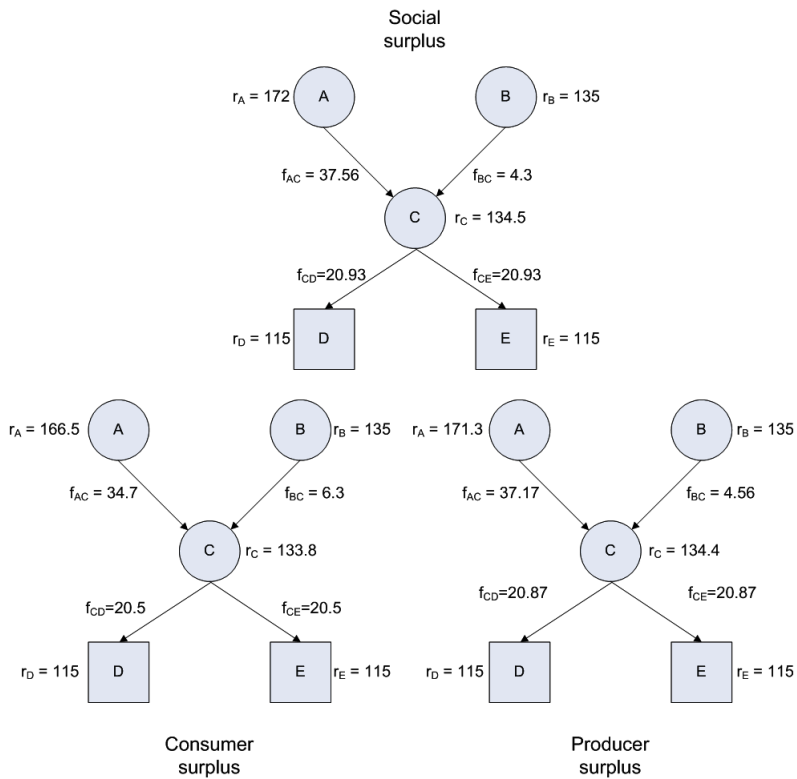
	Objective		
	Social surplus	Consumer surplus	Producer surplus
Production in node $A$	37.56	34.7	37.17
Production in node $B$	4.3	6.3	4.56
Sale in node $D$	20.93	20.5	20.87
Sale in node $E$	20.93	20.5	20.87

**Table 3.9:** Result from optimization.

	Objective			
	Social surplus	Consumer surplus	Producer surplus	Surplus with ISF
$CS$	1095.1	1053.5	1089.2	1123.6
$PS$	733.1	663.6	722.1	674.16
$A$	4715.4	4777.2	4726.6	4884.48
$CS + PS + A$	6543.6	6494.3	6537.9	6682.24

**Table 3.10:** Results from the optimization. See Figure 3.10 for definition of the areas  $A$ ,  $CS$  and  $PS$ .

To summarize the results, we start by noting that in the unconstrained case,



**Figure 3.13:** The solution when maximizing social surplus, consumer surplus and producer surplus with pressure constraints.

the three objective functions will in general lead to different flow patterns in the system. When modeling the physical properties of the network using only ISF capacity limits to restrict the solutions, the different objectives will give identical solutions in terms of flow when the network is sufficiently constrained. For the very constrained network, this means that when using the ISF formulation, the monopsony/monopoly cannot do better than the social surplus solution in terms of changing the size of the areas  $CS$ ,  $A$  and  $PS$ . Only the wealth distribution changes with the objective in this case, due to different assumptions on who is to receive the grid revenue  $A$ . On the other hand, when modeling the network flows with pressure limits and pressure drops, the solutions may differ with different objectives. The possibility of moving bottlenecks in the system when modeling pressure and system effects, allows the monopsony or monopoly to get a higher surplus than they would in the solution with maximal social surplus, and at the expense of the other party.

### 3.6 Conclusions

Due to the physical properties of natural gas transportation networks, there exist severe externalities in the operation and development of these networks. Flows are constrained by pressure limits and driven by pressure drops. This means that changes in one part of the system will influence capacities and performance in other parts of the system. An analysis of bottlenecks and threshold values in the transportation network therefore must have a system perspective rather than a pipeline perspective. Thus, in order to analyze a natural gas transportation system, it is necessary to take into consideration the entire network.

In this paper, we provide a modeling framework that takes into account these externalities. A linearization of the Weymouth equation, that describes flow in a pipeline, is proposed in order to allow for analysis of flows and economic surpluses even in large networks. The effects of the network externalities are investigated by means of numerical examples in a small network consisting of two production nodes, two market nodes and an intermediate transportation node.

From these simple examples, it is demonstrated that the relation between flows in the system is highly non-linear and non-additive. The network externalities may influence to a large extent effective capacities, optimal flow patterns and marginal values or prices. Moreover, it is shown that flexibility in operations arise from these system and pressure effects, in the sense that it is possible to move bottlenecks in the system with a profit for either producers or consumers. The externalities arising from system effects and pressure constraints thus influence even the more qualitative aspects of the solutions, such as the effects from different assumptions on the market design, and the competitive structure of the markets.

Thus, we argue that modeling the physical properties of natural gas networks, taking into account the technology in terms of physics and system effects, is important for economic analysis in natural gas networks.

## Appendix

### 3.A Linearization of the Weymouth equation

The Weymouth equation is given by:

$$W_{ij} = K\sqrt{r_i^2 - r_j^2}. \quad (3.19)$$

By using a first order Taylor series expansion around a fixed point  $RI$ ,  $RO$ , this can be expressed as:

$$W_{ij}(r_i, r_j) \leq W_{ij}(RI, RO) + \frac{\delta W}{\delta r_i}(r_i - RI) + \frac{\delta W}{\delta r_j}(r_j - RO). \quad (3.20)$$

We start by finding the partial derivatives:

$$\frac{\delta W}{\delta r_i} = \frac{2Kr_i}{2\sqrt{r_i^2 - r_j^2}}, \quad (3.21)$$

$$\frac{\delta W}{\delta r_j} = -\frac{2Kr_j}{2\sqrt{r_i^2 - r_j^2}}. \quad (3.22)$$

Putting these expressions into Equation (3.20) and using the fixed point  $RI$ ,  $RO$  we obtain the following result:

$$\begin{aligned} W_{ij}(RI, RO) = & K\sqrt{RI^2 - RO^2} + \frac{KRI}{\sqrt{RI^2 - RO^2}}(r_i - RI) \\ & - \frac{KRO}{\sqrt{RI^2 - RO^2}}(r_j - RO). \end{aligned} \quad (3.23)$$

This can be written as:

$$\begin{aligned} W_{ij}(RI, RO) = & K \left( \sqrt{RI^2 - RO^2} - \frac{RI^2 - RO^2}{\sqrt{RI^2 - RO^2}} + \frac{RI}{\sqrt{RI^2 - RO^2}}r_i \right) \\ & - K \left( \frac{RO}{\sqrt{RI^2 - RO^2}}r_j \right). \end{aligned} \quad (3.24)$$

which finally translates into the following approximation for the flow through a pipeline with pressure difference  $r_i - r_j$ :



$$W_{ij}(RI, RO) = K \left( \frac{RI}{\sqrt{RI^2 - RO^2}} r_i - \frac{RO}{\sqrt{RI^2 - RO^2}} r_j \right). \quad (3.25)$$

The flow surface given by equation 3.19 is the upper quarter of a cone starting in the origin. The linearization constraints are planes passing through the origin. Each such plane linearized around  $(RI, RO)$  is tangent to the cone in all points where  $\frac{r_i}{r_j} = \frac{RI}{RO}$ . For more details, see Westphalen (2004).

### 3.B Unconstrained equilibrium

Consider a single pipeline where the capacity of the pipeline is not binding. Also assume demand and supply functions are known and linear. For a more details regarding these calculations, see for instance Tirole (1988):

$$\text{Demand: } p^d = \alpha^d - \beta^d k_g, \quad (3.26)$$

$$\text{Supply: } p^s = \alpha^s + \beta^s q_m. \quad (3.27)$$

When looking at a system with a single pipeline the production,  $k_g$ , and sold volume,  $q_m$ , are identical and equal to the flow in the pipeline,  $f$ . The highest possible social surplus is achieved for the system in a competitive market, where the prices are  $p^{d*}$  and  $p^{s*}$ , and the traded quantity is  $f^*$  corresponding to the intersection between the supply- and demand curves:

$$f^* = \frac{\alpha^d - \alpha^s}{\beta^s + \beta^d} \Rightarrow p^{d*} = p^{s*} = \frac{\alpha^d \beta^s + \alpha^s \beta^d}{\beta^s + \beta^d}. \quad (3.28)$$

Maximization of producer surplus can be done by implementing the monopoly solution. In order to find the monopoly price and quantity, the intersection between marginal revenue and marginal cost is found. This gives the following solution:

$$MC = \alpha^s + \beta^d f, \quad (3.29)$$

$$MR = \alpha^d - 2\beta^d f, \quad (3.30)$$

$$\begin{aligned} MC = MR \Rightarrow f^* &= \frac{\alpha^d - \alpha^s}{\beta^s + 2\beta^d} \Rightarrow p^{d*} = \frac{\alpha^d \beta^s + \alpha^d \beta^d - \alpha^s \beta^d}{\beta^s + 2\beta^d}, \\ p^{s*} &= \frac{2\alpha^s \beta^d + \alpha^d \beta^s}{\beta^s + 2\beta^d}. \end{aligned} \quad (3.31)$$

The social surplus is reduced since the traded quantity in this solution is different from the competitive markets' solution. In this case the surplus of the producers' is maximized.

In the opposite case, total consumer surplus is maximized through the monopsony solution. In order to find the monopsony solution, first the marginal expenditure curve ( $ME$ ) must be found. The marginal expenditure curve is equal to the derivative of the cost function ( $C$ ) for the monopsony:

$$C = \alpha^s f + \beta^s f^2, \quad (3.32)$$

$$ME = \alpha^s + 2\beta^s f, \quad (3.33)$$

The optimal solution is found at the intersection of this curve and the marginal revenue product ( $MRP$ ) curve (assumed equal to the demand curve):

$$\begin{aligned} ME = MRP \Rightarrow f^* &= \frac{\alpha^d - \alpha^s}{2\beta^s + \beta^d} \Rightarrow p^{d*} = \frac{2\alpha^d\beta^s + \alpha^s\beta^d}{\beta^d + 2\beta^s}, \\ p^{s*} &= \frac{\alpha^s\beta^d + \alpha^s\beta^s + \alpha^d\beta^s}{\beta^d + 2\beta^s}. \end{aligned} \quad (3.34)$$

## Bibliography

- An, S., Qing, L. & Gedra, T. (2003), 'Natural gas and electricity optimal power flow', *Proceedings of the IEEE/PES Transmission and Distribution Conference, Dallas* .
- Bjørndal, M. (2000), Topics on Electricity Transmission Pricing, PhD thesis, Norwegian School of Economics and Business Administration, Bergen.
- Campbell, J. (1992), *The Equipment Modules, Gas Conditioning and Processing*, 7 edn, Norman, Okla.
- Chao, H. & Peck, S. (1996), 'A market mechanism for electric power transmission', *Journal of Regulatory Economics* **10**(1), 25–59.
- Cremer, H., Gasmi, F. & Laffont, J. (2003), 'Access to pipelines in competitive gas markets', *Journal of Regulatory Economics* **24**(1), 5–33.
- Cremer, H. & Laffont, J. (2002), 'Competition in gas markets', *European Economic Review* **46**, 928–935.
- De Wolf, D. & Smeers, Y. (2000), 'The gas transmission problem solved by an extension of the simplex algorithm', *Management Science* **46**(11), 1454–1465.
- Ehrhardt, K. & Steinbach, M. (2004), 'KKT systems in operative planning for gas distribution networks', *Proceedings in applied mathematics and mechanics* **4**(1), 606–607.
- Ehrhardt, K. & Steinbach, M. (2005), Nonlinear optimization in gas networks, in H. E. Bock, ed., 'Modeling, Simulation and Optimization of Complex Processes', Springer-Verlag, Berlin - Heidelberg - New York, pp. 139–148.
- European Commission, D.-G. f. E. & Transport (2002), 'Opening up to choice: Launching the single european gas market', Office for Official Publications of the European Communities.
- European Union (1998), 'Directive 98/30/EC of the european parliament and of the council'.
- European Union (2003), 'Directive 2003/55/EC of the european parliament and of the council'.

- Gabriel, S., Kydes, A. & Whitman, P. (2001), ‘The national energy modeling system: A large-scale energy-economic equilibrium model’, *Operations Research* **49**(1), 14–25.
- Gabriel, S. & Smeers, Y. (2006), Recent advances in optimization. lecture notes in economics and mathematical systems, *in* A. Seeger, ed., ‘Complementarity Problems in Restructured Natural Gas Markets’, Springer-Verlag, Berlin Heidelberg, pp. 343–373.
- Gabriel, S., Kiet, S. & Zhuang, J. (2005), ‘A mixed complementarity-based equilibrium model of natural gas markets’, *Operations Research* **53**(5), 799–818.
- Hogan, W. (1993), ‘Markets in real electric networks require reactive prices’, *The Energy Journal* **14**(3), 171–200.
- Martin, A., Möller, M. & Moritz, S. (2006), ‘Mixed integer models for the stationary case of gas network optimization’, *Mathematical Programming* **105**(2-3), 563–582.
- Rømo, F., Fodstad, M., Tomasgard, A., Hellemo, L. & Nowak, M. (2006), An optimization system using steady state model for optimal gas transportation on the norwegian continental shelf, Technical report, SINTEF, Trondheim, Norway.
- Rømo, F., Tomasgard, A., Fodstad, M. & Midthun, K. (2004), Stochastic optimization of the natural gas value chain in a liberalized market, Technical report, SINTEF, Trondheim, Norway.
- Schweppe, F., Caramanis, M., Tabors, R. & Bohn, R. (1988), *Spot Pricing of Electricity*, Kluwer Academic Publishers, Norwell, Massachusetts.
- Tirole, J. (1988), *The Theory of Industrial Organization*, MIT Press, London Cambridge.
- Van der Hoeven, T. (2004), Math in Gas and the Art of Linearization, PhD thesis, International business school and research center for natural gas, Groningen, The Netherlands.
- Westphalen, M. (2004), Anwendungen der Stochastischen Optimierung im Stromhandel und Gastransport, PhD thesis, University Duisburg-Essen (Germany).
- Wu, F., Varaiya, P., Spiller, P. & Oren, S. (1996), ‘Folk theorems on transmission access: Proofs and counterexamples’, *Journal of Regulatory Economics* **10**(1), 5–23.

## Paper III

Kjetil T. Midthun, Matthias P. Nowak and Asgeir Tomasgard:

### *An operational portfolio optimization model for a natural gas producer*

*Submitted to international journal*



## Chapter 4

# An operational portfolio optimization model for a natural gas producer

### **Abstract:**

We present a short-term portfolio optimization model for a large natural gas producer. The time horizon in the model is one week with daily resolution. In this time-span the model includes spot market sales, production plans, storage management and fulfillment of long-term contracts. The paper discusses the value of actively using the storage capacity provided by the line-pack of the pipelines to maximize profit for the producer. We also study the value of using a stochastic model as compared to a deterministic model. The model is tested over two 60-days periods using real market data and realistic production and transportation capacities.

## 4.1 Introduction

We present an operational portfolio planning model for a large offshore producer of natural gas. The objective for the producer is to maximize the value of the produced natural gas within a week. The production targets are given as daily and weekly volumes that must meet upper and lower production requirements for each field.

The entities that we model in the natural gas networks are: production fields present in production nodes, pipelines between nodes, junction nodes where pipelines meet and gas is blended, compressors used to lift the pressure in the network at given nodes, and market nodes at which gas is sold through take-or-pay contracts or at the spot market. In addition we look at storage in the pipeline system. The producer strives to send more gas to the market on days with high prices and less on days with low prices, while the overall produced volume does not change within the week. When maximizing the value of production, the gas producer must consider both physical limitations as well as guidelines from tactical/ strategic models and field lifting agreements (e.g. production limits). The portfolio planning covers coordination of production in a set of fields, transportation in pipelines, management of storage and sales through contracts and spot markets.

To our knowledge this is the first study of a stochastic portfolio optimization

model for natural gas production and sales. We examine the value of using a stochastic model, as compared to a deterministic approach. In addition, we evaluate the commercial value of actively using the storage (line-pack) present in the export pipelines in order to increase the average price of the sold gas. Any other storage capacity with close proximity to the market hubs like aquifers, caverns, LNG-storages and abandoned oil- and gas reservoirs, can easily be included in the model as well. The modelling of pipelines as storages and the interaction with compressors to achieve this is non-trivial and our approach goes beyond the methods reported in the current literature. Our analysis is motivated by the gas production on the Norwegian continental shelf. The analysis is also relevant for other regions where contract markets and spot-markets exist together and where storage of gas may be used to increase the profit.

Our model is a continuation of the work presented in Tomasgard et al. (2007) that gives an introduction to modelling the value chain for natural gas covering both system effects, multi-commodity aspects of natural gas flow and portfolio optimization. That model is at a tactical level with a monthly resolution, no computational results are presented, no price model is given and storage in pipelines is not included. In related literature Nygreen et al. (1998) considers deterministic investment optimization for oil and gas fields in a strategic horizon with focus on how to develop fields and build pipelines. In Iyer et al. (1998) a multi-period mixed-integer linear programming model for scheduling investment and operation in offshore oil field facilities is presented. Stochastic models for planning offshore gas field developments under uncertainty in reserves is presented in Goel & Grossmann (2004) and in Haugen (1996). Ulstein et al. (2007) give a model for deterministic tactical value chain coordination including the multi-commodity aspects of natural gas. That approach does not include a physical model for the natural gas flow and thereby neglects the important system effects in the transportation networks (Midthun et al. 2006) and also does not allow the modelling of storage in pipelines. In Selot et al. (2007) a MINLP model for operational planning for upstream natural gas production systems is presented. The model gives a detailed description of the physical properties of natural gas production and transportation.

In Thompson et al. (2003) an algorithm for the valuation and optimal operation of a single natural gas storage facility is presented, and Byers (2006) present a valuation methodology for commodity storage facilities.

In our test case we use real market prices from 3 European hubs and realistic production and transportation capacities from the Norwegian continental shelf. This is the world's largest offshore pipeline network for natural gas and produces about 15 % of the European consumption of natural gas. We simplify the analysis by assuming that one player can control both all production fields and the transportation network. Our analysis here is on the value of portfolio optimization,



coordination and storage, not on how the profit should be shared between players or how the market should be organized. For analysis of the organization of multi player behavior in the transportation market, see Gabriel & Smeers (2005) and Midthun et al. (2007). Examples of computational equilibrium models for natural gas markets are Gabriel et al. (2005) and Zhuang & Gabriel (2006).

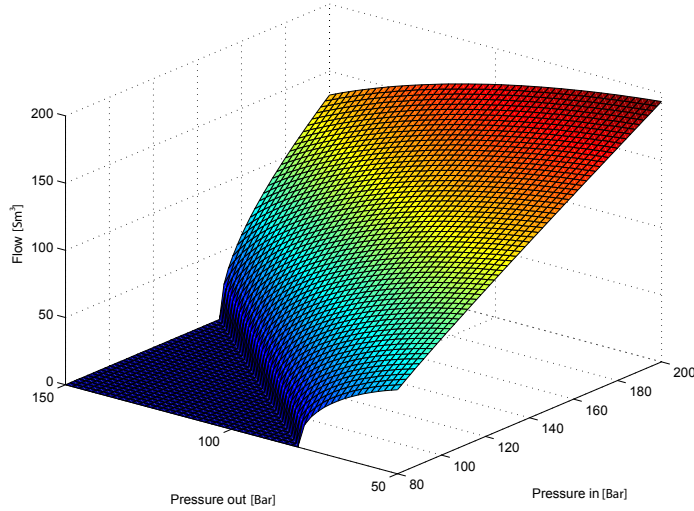
We build on a linear steady-state model for the transportation network based on Tomsgard et al. (2007). An alternative mixed integer approach is presented in Martin et al. (2006). An overview of linearization of natural gas flow is given in Van der Hoeven (2004). All papers mentioned so far are steady-state models. Work has also been done on modeling of the transient behavior of gas flow. An overview can be found in Kelling et al. (2000). In Westphalen (2004) and Nowak & Westphalen (2003) models for transient flow in a system of gas transportation pipelines are presented. A deterministic version of the model in Nowak & Westphalen (2003) is implemented in Nørstebø (2004). Here the time resolution is in hours. Our work on modelling storage in pipelines builds on and extends the approaches in Westphalen (2004) and Kelling et al. (2000).

In Section 4.2 we discuss important aspects of natural gas transportation. A mathematical formulation is given in Section 4.3. In Section 4.4 we present the market models and more details of the computational cases. We then present the results in Section 4.5 and concludes.

## 4.2 Modeling natural gas networks

An important implication of the liberalization process of the European gas industry is the development of short-term markets in Europe. Now the producers of natural gas have the possibility to sell their gas through, for instance, week-ahead, day-ahead and within-day contracts, in addition to long-term contracts. The majority of produced gas is still sold through long-term take-or-pay contracts (TOP) where the producer has little opportunity to increase profitability. The structure of the take-or-pay contracts calls for careful planning. The buyer in the take-or-pay contracts has flexibility with respect to the weekly, as well as daily, nominated volume. Consequently, volumes sold in the short-term markets are the only factor the producer may influence, and these deliveries will never be prioritized above the TOP-contracts. Spot markets therefore represent an important opportunity for increased profit as an increase of the average spot price achieved will be reflected directly in the company's profit, but also a challenge in terms of the security of supply for TOP contracts. This means that the planning decisions have to be flexible and able to meet varying demands.

We here discuss how to model pressure constraints, and move on to discuss the importance of transient behavior of the gas versus steady-state modelling. Then we discuss the representation of line-pack as storage in the portfolio optimization



**Figure 4.1:** The Weymouth equation.

together with the representation of compressors used to control this storage.

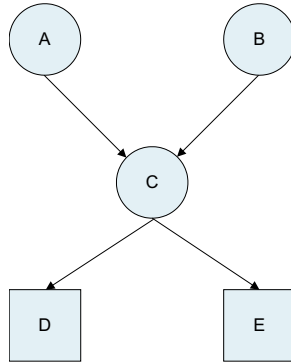
### Modelling pressure and system effects

In a natural gas transportation network the capacity in a pipeline depends on the design parameters of the pipeline (such as length and diameter), as well as on the pressure at the inlet and the pressure at the outlet. The Weymouth-equation is often used to describe flow in a pipeline as a function of the inlet and outlet pressure as well as design parameters (see Figure 4.1). For more details on the Weymouth-equation, see for instance Campbell (1992).  $F_{ij}(p_i, p_j)$  approximates the flow through a pipeline going from node  $i$  to node  $j$  as a function of the input pressure  $p_i$  and output pressure  $p_j$ :

$$F_{ij}(p_i, p_j) = K_{ij}^W \sqrt{p_i^2 - p_j^2}, \quad j \in \mathcal{N}, i \in \mathcal{I}(j). \quad (4.1)$$

$K_{ij}^W$  is the Weymouth constant for the pipeline going from  $i$  to  $j$ . This constant depends on the pipelines length, its diameter and other pipeline specific parameters.

Consider the network in Figure 4.2. The flow in the pipeline  $AC$  from  $A$  to  $C$  depends on the pressure level in node  $A$  and  $C$ . The pressure in node  $C$  influences



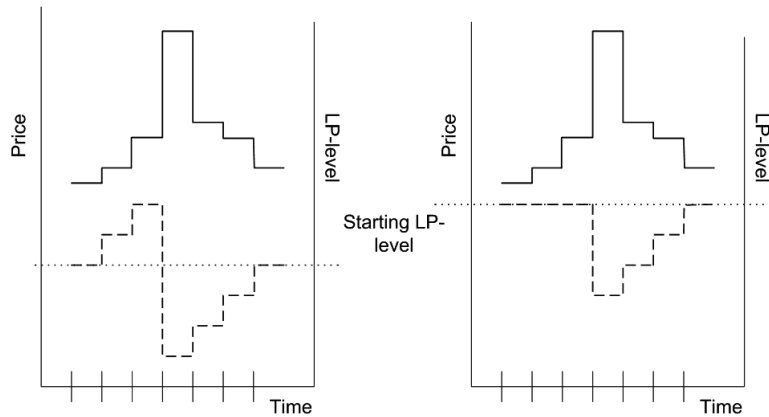
**Figure 4.2:** Example of a transportation network consisting of two production nodes, a transportation node and two market nodes.

the flow both in  $AC$  and  $CD$ . If the pressure in node  $C$  increases, the flow from  $A$  to  $C$  decreases while the flow from  $C$  to  $D$  increases. Flow in one pipeline in the network influences the potential flow in the rest of the network. If fixed capacities are used for the pipelines instead of pressure constraints, the system effects are neglected. For a more detailed motivation for our steady state linearization and discussion of system effects we refer to Midthun et al. (2006).

### Transient natural gas flow and pipelines as storage

Steady-state models assume that inflow and outflow of gas is equal within a period. However, long transportation pipelines may also be used as storages. The line-pack in a pipeline is the gas contained in the pipeline. In the graph to the left in Figure 4.3 a possible use of line-pack is shown for a case where the pipeline is 90% full and a given price development. In the graph to the right we see the development when the pipeline is already filled to max capacity (Figure 4.3). The line-pack can be increased when prices are expected to increase and decreased when prices are favorable.

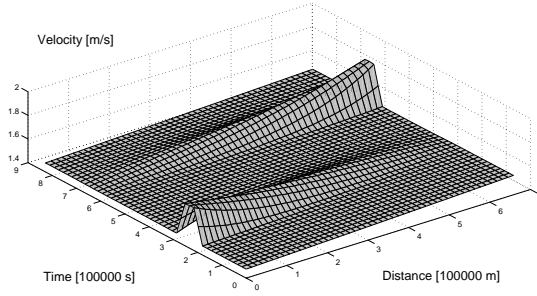
Often, in order to model time and storage capacity, the pipeline is divided into several segments with steady-state conditions in each segment. Applying well known time-length criteria to long sub sea pipelines will result in a high number of segments (Osiaclacz 1983, Streeter & Wylie 1970). In an operational model with daily resolution and routing flexibility we need to check whether a simple steady-state formulation will still be meaningful, or whether we need to use one of the more complicated models partitioning the pipelines into a set of steady-state segments.



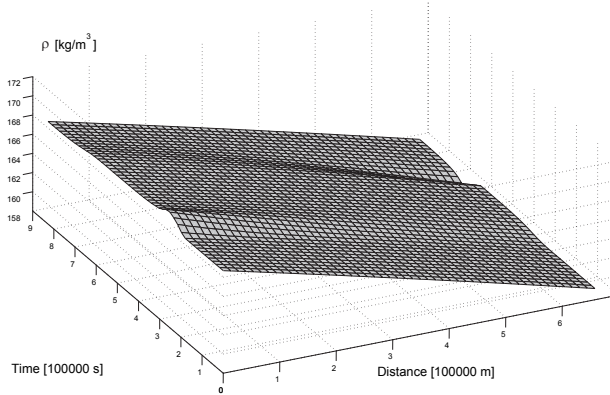
**Figure 4.3:** Line-pack: The horizontal line shows the starting level of line-pack, the dotted line shows the level of line-pack and the full line shows the price development.

When the amount of gas taken out of the pipeline is less than the amount of gas sent into it (in practice additional gas is being pushed in) the pressure and density at the inlet is rising. A sudden increase of inflow will cause a pressure wave that goes through the pipeline at the speed of sound. The intensity of the pressure wave is decreasing since the energy is used to push gas particles toward the outlet, causing both a slight increase of velocity and density also there. This effect is shown in Figures 4.4 to Figure 4.5. We use Matlab to simulate the development of velocity and density of the gas molecules in a gas pipeline for given input and output profiles. The simulation is performed in the same manner as described in Nowak & Westphalen (2003), where differential equations are used to describe the transient gas flow in a pipeline. An increase in the outflow will lead to a similar pressure wave, this time going from the outlet toward the inlet and sucking gas out of the whole pipeline. At each point in time the pressure decreases along the pipeline, while the velocity increases, since the energy for the gas transport is stored in the compression. The figures illustrate that short term variations in input and outtake have little impact on both velocity and density in the middle of the pipeline or the other end of the pipeline.

We then look at a situation where we use a time resolution of 24-hours (the flow rate is constant within each 24-hour period, but in the simulation we show hourly effect on pressure and velocity). The chosen input/output-pattern, as well as the resulting inlet and outlet pressure is illustrated in Figure 4.6. The figure shows that the inlet and outlet pressure in the pipeline is an approximately piecewise linear function. The figure also illustrates that there is transient behavior in the

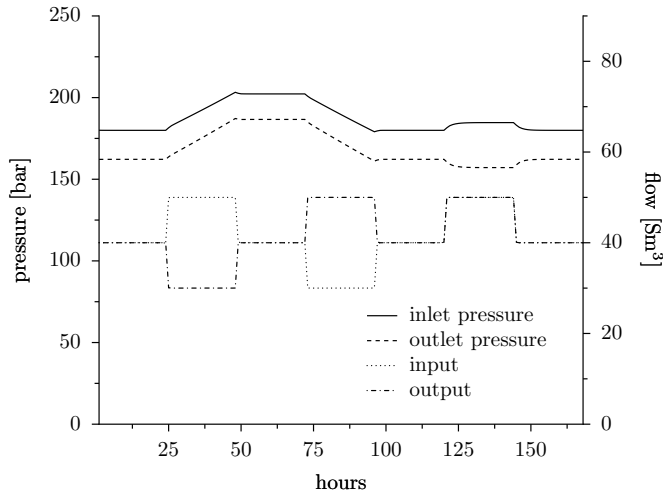


**Figure 4.4:** Simulation of velocity for a small variation in input and output.



**Figure 4.5:** Simulation of density ( $\rho$ ) for a small variation of first input and then output.

pipeline in the first hours after a change in input and/or output in the pipeline. This can be seen from the non-linear behavior of the inlet and outlet pressure in the hours after a changed flow pattern. With a time-resolution of less than an hour, this non-linear behavior will be important. We argue however, that with a time-resolution of 24-hours, a modified steady-state approach is sufficient.



**Figure 4.6:** Resulting inlet and outlet pressure from given input/output data.

The modified steady-state approach is based on steady-state equations, but allows for different in- and outflow quantities in the pipelines. We extend this formulation with a storage model that depends on a weighted average of the pressures at the inlet and outlet points of the pipeline. In Westphalen (2004) the line-pack is calculated as a function of average pressure in the pipeline ( $p_{ij}^{avg} = \frac{1}{2}(p_i + p_j)$ , where  $p_i$  is the pressure at the inlet and  $p_j$  is the pressure at the outlet). We have used a formula that in addition considers the shape of the pressure drop in the pipeline (Kelling et al. 2000):

$$p_{ij}^{avg} = \frac{2}{3} \left( p_i + p_j - \frac{p_i p_j}{p_i + p_j} \right). \quad (4.2)$$

This expression can be linearized in the following way (by using a first-order Taylor expansion):

$$p_{ij}^{avg} = \frac{2}{3} \left( p_i + p_j - \frac{P_i^{avg} P_j^{avg}}{P_i^{avg} + P_j^{avg}} - \frac{P_j^{avg} (p_i - P_i^{avg})}{P_i^{avg} + P_j^{avg}} - \frac{P_i^{avg} (p_j - P_j^{avg})}{P_i^{avg} + P_j^{avg}} \right), \quad (4.3)$$

where  $P_i^{avg}$  and  $P_j^{avg}$  are constants, representing the approximated average inlet and outlet pressure in the pipeline. In addition, we need an Equation of State in order to relate the average pressure in the pipeline to the average density in the pipeline. For a discussion on different versions of the Equation of State, see Modisetta (2000). We use the following form:

$$p = \rho \frac{R}{m} T z(p, T), \quad (4.4)$$

where  $\rho$  is the density in the pipeline,  $R$  is the Gas constant,  $m$  is the molecular weight and  $z(p, T)$  is the compressibility factor as a function of pressure  $p$  and temperature  $T$ . The value of  $z$  is chosen to be 0.7 in this paper based on experience from the pipelines at the Norwegian continental shelf (Dahl 2001). For a constant temperature  $T$ ,  $z$  is still varying in pressure, but for our relevant pressure levels the variations are small.

When using this Equation of State, we can find the density in the pipeline as a function of the average pressure in the pipeline. We can then estimate the line-pack by multiplying the density with the volume of the pipeline:

$$LP_{ij} = \frac{m}{RTz} p_{ij}^{avg} A_{ij} L_{ij}, \quad (4.5)$$

where  $LP_{ij}$  is the line-pack in the pipeline between  $i$  and  $j$ ,  $A_{ij}$  is the area of a cross-section of the pipeline and  $L_{ij}$  is the length of the pipeline. The complete formulation is given in Section 4.3, Equations (4.16)-(4.18).

## Compressor modeling

For production fields we do not consider the physics in the reservoirs. The modeling starts when gas enters the compressors that build up pressure for the pipeline transportation. The cost of running a compressor depends on the inlet and outlet pressure, and the gas flow. The compressor work, as an isentropic process is given by (Katz & Lee 1990):

$$W = Aq \left[ \left( \frac{P^{out}}{P^{in}} \right)^{\frac{\gamma}{\gamma-1}} - 1 \right], \quad (4.6)$$

where  $W$  is the work of the compressor,  $P^{in}$  is the pressure of the gas entering the compressor and  $P^{out}$  is the gas leaving the compressor (corresponds to the

inlet pressure at the connected pipeline). Here  $\chi$  is the adiabatic constant and  $A$  represents the aggregation of various constants in the equation. In the following, the compressor work will be replaced with the cost of running the compressor assuming a constant energy price.

The function is neither strictly convex nor concave. This makes it difficult to represent the function in an optimization model. Including the original compressor cost function leads to a non-convex problem. One approach is presented in Nowak (2006). This method works well for a deterministic model (Nørstebø 2004), and gives a very good approximation of the actual compressor costs. However, the method is not efficient enough to be used for the model sizes that we are considering. The solution times for stochastic network models with 3-5 stages, and from 500 to 1000 scenarios will be too high for practical use. Therefore, to simplify Equation (4.6) we assume constant input pressure to the compressor.

The compressor cost is linearized with the following constraints:

$$c_{gts} \geq a_1 + b_1 (d_{gts} - \underline{d}_g) + c_1 (p_{gts} - \underline{p}_g), g \in \mathcal{G}, t \in \mathcal{T}, s \in \mathcal{S}, \quad (4.7)$$

$$c_{gts} \geq a_2 - b_2 (\bar{d} - d_{gts}) - c_2 (\bar{p}_g - p_{gts}), g \in \mathcal{G}, t \in \mathcal{T}, s \in \mathcal{S}, \quad (4.8)$$

$$c_{gts} \geq a_3 + b_3 (d_{gts} - \underline{d}_g) - c_3 (\bar{p}_g - p_{gts}), g \in \mathcal{G}, t \in \mathcal{T}, s \in \mathcal{S}, \quad (4.9)$$

$$c_{gts} \geq a_4 - b_4 (\bar{d}_g - d_{gts}) + c_4 (p_{gts} - \underline{p}_g), g \in \mathcal{G}, t \in \mathcal{T}, s \in \mathcal{S}, \quad (4.10)$$

Here  $d_{gts}$  and  $p_{gts}$  is the production and outlet pressure in field  $g$  at time  $t$  in scenario  $s$  and the overlined and underlined values give the maximum and minimum values of the variables, respectively. Then  $c_g$  is the approximated compressor cost at production field  $g$ . Constants  $a, b, c$  are positive and describe the plane used for approximation.

### 4.3 The portfolio optimization model

We model the uncertainty in prices and volumes using scenario trees in a 3-stage stochastic program (see e.g. Kall & Wallace (1994)). It has seven time periods and daily resolution. We start here with the description of the scenario trees and the time structure of the model and then give the mathematical formulation.

#### Scenario structure and rolling horizon

Assume that our model starts on a Monday. The model horizon then comprises the weekdays from Monday to Sunday. We implement the first stage decisions (the decisions for Monday) and run the model again on Tuesday (with the weekdays from Tuesday to next Monday). The parameters regarding production levels



for each field, remaining production limits for the week and line-pack levels are updated between the runs. Also the scenario tree structure depends on which weekday the model is run, see Figure 4.7. The reason for this is the special structure of the weekend where all markets for Friday, Saturday and Sunday are cleared on Friday.

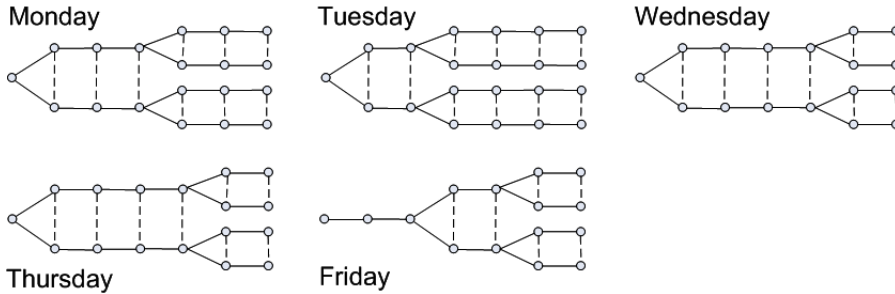


Figure 4.7: The different scenario trees

## Notation

### Sets

- $\mathcal{N}$  The set of all nodes in the network.
- $\mathcal{G}$  The set of production nodes in the network.
- $\mathcal{B}$  The set of junction nodes in the network.
- $\mathcal{M}$  The set of market nodes in the network.
- $\mathcal{I}(n)$  The set of originating nodes with pipelines going into node  $n$ .
- $\mathcal{O}(n)$  The set of end nodes for pipelines going out of node  $n$ .
- $\mathcal{T}$  The set of time periods.
- $\mathcal{S}$  The set of scenarios.
- $\mathcal{Z}$  The set of constraints used to linearize the Weymouth equation.

### Indexes

- $n$  Index used for nodes in general. When more indexes are needed,  $i$  and  $j$  will be used.
- $g$  Index for production nodes.
- $b$  Index for junction nodes.
- $m$  Index for market nodes.
- $t$  Time period index.
- $s$  Scenario index.
- $z$  Index for linearized Weymouth constraints.

### Constants

$\overline{G}_g$	The maximum daily production level in field $g$ .
$\underline{G}_g$	The minimum daily production level.
$\overline{H}_g$	The maximum weekly production level.
$\underline{H}_g$	The minimum weekly production level.
$\overline{P}_n$	The maximum pressure in node $n$ .
$\underline{P}_n$	The minimum pressure in node $n$ .
$K_{ij}$	The Weymouth constant for the pipeline going from $i$ to $j$ .
$PI_z$	Fixed point for pressure into a pipeline.
$PO_z$	Fixed point for pressure out of a pipeline.
$A$	Constant in the compressor work function.
$\chi$	Adiabatic constant.
$R_m$	Price in the take or pay contract in market $m$ .
$B_g$	Constant to convert compressor work to compressor cost.
$P_i^{avg}$	Approximated average pressure into the pipelines in node $i$ .
$P_j^{avg}$	Approximated average pressure in the pipelines entering node $j$ .

### Decision variables

$d_g$	Production in field $g$ .
$q_m$	Spot sale in market $m$ .
$v_m$	Delivery in take or pay contract in market $m$ .
$f_{ij}$	The flow between node $i$ and $j$ .
$p_n$	The pressure in node $n$ .
$p_{ij}^{avg}$	The average pressure in the pipeline going from node $i$ to $j$ .
$LP_{ij}$	Line-pack in the pipeline going from $i$ to $j$ .
$c_g$	Cost of compressor in field $g$ .
$q_{ij}^{in}$	Volume inserted to the pipeline going from $i$ to $j$ .
$q_{ij}^{out}$	Volume extracted from the pipeline going from $i$ to $j$ .

### Stochastic variables and probabilities

$v_m$	Nomination in long-term contracts in market $m$ .
$r_m$	Spot price in market $m$ .
$\pi$	Probability of a given scenario.

### Functions

$F(p_i, p_j)$	Flow in a pipeline with inlet pressure $p_i$ and outlet pressure $p_j$ .
$W(q, P_{in}, P_{out})$	Work of a compressor.

## The mathematical model

The model maximizes expected income from sales in the spot market and deliveries in long-term contracts minus the costs of using the network. The costs incorporate the compressor costs and production costs:

$$\Pi = \sum_{s \in \mathcal{S}, t \in \mathcal{T}} \pi_{ts} \left[ \sum_{m \in \mathcal{M}} (r_{mts} q_{mts} + R_m v_{mts}) - \sum_{g \in \mathcal{G}} (c_{gts} + \kappa_g d_{gts}) \right]. \quad (4.11)$$

Here  $\pi_{ts}$  is the probability of scenario  $s$  in time  $t$ ,  $q_{mts}$  is the volume of gas sold in market  $m$ , while  $r_{mts}$  is the price obtained for this gas in market  $m$ . The second term gives the revenues from the long-term contracts:  $v_{mts}$  is the volume delivered in long-term contracts in market  $m$  while  $R_m$  is the price obtained. The last term gives the cost of the compressors and the production cost. The parameter  $\kappa_g$  is the cost per unit of production  $d_{gts}$ , in field  $g$ , and  $c_{gts}$  is the cost of the compressor in field  $g$ . The compressor cost is modeled with constraints (4.7) to (4.10).

At each field there is a minimum and a maximum volume that can be produced by the company. These limitations are due to both the properties of the field and the guidelines from a tactical plan. The limits are given both on a daily and a weekly level. The total production should be within a given interval. The daily limits are given by:

$$\underline{G}_g \leq d_{gts} \leq \overline{G}_g, \quad g \in \mathcal{G}, \quad t \in \mathcal{T}, \quad s \in \mathcal{S}, \quad (4.12)$$

where  $\underline{G}_g$  is the lower production limit,  $\overline{G}_g$  is the upper limit and  $d_{gts}$  is the production in the field. The weekly limits are formulated as:

$$\underline{H}_g \leq \sum_{t \in \mathcal{T}} d_{gts} \leq \overline{H}_g, \quad g \in \mathcal{G}, \quad s \in \mathcal{S}, \quad (4.13)$$

where  $\underline{H}_g$  is the lower limit on weekly production and  $\overline{H}_g$  is the upper limit on weekly production.

As discussed in Section 4.2, we model the transportation system as a steady-state system. The Weymouth-equation is used to relate the pressure difference and design parameters of the pipelines to the flow in the pipeline. In order to get a linear model, we use the same linearization as Tomasgard et al. (2007) and Rømo et al. (2007). This gives the following constraints for the model without line-pack:

$$\begin{aligned}
 f_{ijts} &\leq K_{ij}^W \frac{PI_z}{\sqrt{PI_{iz}^2 - PO_{jz}^2}} p_{its} \\
 &- K_{ij}^W \frac{PO_z}{\sqrt{PI_{iz}^2 - PO_{jz}^2}} p_{jts}, \quad j \in \mathcal{N}, i \in \mathcal{I}(j), z = 1, \dots, Z,
 \end{aligned} \tag{4.14}$$

where  $(PI_z, PO_z)$  are break-points for the linearization representing pressure at both ends of the pipeline. We use  $Z$  such constraints to linearize the Weymouth equation, each with a different ratio  $\frac{PI_z}{PO_z}$ , see Tomsgard et al. (2007). The inlet pressure in the pipeline is given by  $p_{its}$ , the outlet pressure is  $p_{jts}$  and the resulting flow is  $f_{ijts}$ .  $K_{ij}^W$  is the Weymouth constant for the pipeline going from  $i$  to  $j$ .

For the model with line-pack it is the net daily change of the volume in the pipeline that matters, hence we substitute the variable  $f_{ij}$  with two new variables:  $q_{ij}^{in}$  and  $q_{ij}^{out}$ , representing input and output. The Weymouth-equation can then be written as:

$$\begin{aligned}
 \frac{1}{2} (q_{ijts}^{in} + q_{ijts}^{out}) &\leq K_{ij}^W \frac{PI_z}{\sqrt{PI_{iz}^2 - PO_{jz}^2}} p_{its} \\
 &- K_{ij}^W \frac{PO_z}{\sqrt{PI_{iz}^2 - PO_{jz}^2}} p_{jts}, \quad j \in \mathcal{N}, i \in \mathcal{I}(j), z = 1, \dots, Z.
 \end{aligned} \tag{4.15}$$

As discussed in Section 4.2 the line-pack in a pipeline is found by multiplying the approximated density with the volume of the pipeline.

$$LP_{ijts} = \frac{m}{RT_z} p_{ijts}^{avg} A_{ij} L_{ij}, \quad i \in \mathcal{N}, j \in \mathcal{O}(i), t \in \mathcal{T}, s \in \mathcal{S}, \tag{4.16}$$

where  $LP_{ij}$  is the line-pack in the pipeline between  $i$  and  $j$ ,  $A_{ij}$  is the area of a cross-section of the pipeline and  $L_{ij}$  is the length of the pipeline. The line-pack inventory is given by:

$$LP_{ij,t+1,s} = LP_{ijts} + q_{ijts}^{in} - q_{ijts}^{out}, \quad i \in \mathcal{N}, j \in \mathcal{O}(i), t \in \mathcal{T} \setminus \{T\}, s \in \mathcal{S}. \tag{4.17}$$

As a business constraint we require that the level of line-pack at the end of horizon is equal to the starting level. This is in order to not deplete the line-pack which is also used as a buffer in order to secure supply:

$$LP_{ij,T,s} + q_{ijTs}^{in} - q_{ijTs}^{out} = LP_{ij1s}, \quad i \in \mathcal{N}, j \in \mathcal{O}(i), s \in \mathcal{S}, \tag{4.18}$$

where  $T$  is the last time period. Constraint (4.18) is necessary to take care of end-of-horizon effects. If the constraint had not been included, the line-pack level would have been reduced to a minimum in period  $T$ . Alternative ways of formulating this constraint is to include a value of the gas in period  $T$  (for instance based on an Expected Gas Value Function, as presented in Tomasgard et al. (2007)).

The pressure in the nodes needs to be within maximum and minimum requirements. These requirements come from compressor capacities, design parameters of the network and contractual agreements:

$$\underline{P}_i \leq p_{its} \leq \overline{P}_i, \quad i \in \mathcal{N}, t \in \mathcal{T}, s \in \mathcal{S}. \quad (4.19)$$

In the production nodes we must make sure that the produced quantity,  $d_{gts}$ , of gas is flowing into the connected pipelines,  $f_{gits}$ . The formulation without line-pack is:

$$d_{gts} = \sum_{i \in \mathcal{O}(g)} f_{gits}, \quad g \in \mathcal{G}, t \in \mathcal{T}, s \in \mathcal{S}, \quad (4.20)$$

and with line-pack it is:

$$d_{gts} = \sum_{i \in \mathcal{O}(g)} q_{gits}^{in}, \quad g \in \mathcal{G}, t \in \mathcal{T}, s \in \mathcal{S}. \quad (4.21)$$

In the junction nodes, the amount of gas that enters the node must be equal to the amount leaving the node. The formulation without line-pack is:

$$\sum_{i \in \mathcal{I}(k)} f_{ikts} = \sum_{j \in \mathcal{O}(k)} f_{kjts}, \quad k \in \mathcal{B}, t \in \mathcal{T}, s \in \mathcal{S}, \quad (4.22)$$

and with line-pack it is:

$$\sum_{i \in \mathcal{I}(k)} q_{ikts}^{out} = \sum_{j \in \mathcal{O}(k)} q_{kjts}^{in}, \quad k \in \mathcal{B}, t \in \mathcal{T}, s \in \mathcal{S}. \quad (4.23)$$

$\mathcal{B}$  is the set of junction nodes in the network.

In the market nodes the company sell  $q_{mts}$  in the spot market. Additionally, the company must deliver long-term contracted volumes ( $v_{mts}$ ). The mass balance equation for the market nodes for the formulation without line-pack is:

$$q_{mts} = \sum_{i \in \mathcal{I}(m)} f_{imts} - v_{mts}, \quad m \in \mathcal{M}, t \in \mathcal{T}, s \in \mathcal{S}, \quad (4.24)$$

and with line-pack it is:

$$q_{mts} = \sum_{i \in \mathcal{I}(m)} q_{imts}^{out} - v_{mts}, \quad m \in \mathcal{M}, t \in \mathcal{T}, s \in \mathcal{S}. \quad (4.25)$$

Since it is assumed that the company cannot influence the prices in the market nodes, there are no restrictions on how much the company can buy or sell in the market. The demand is assumed to be completely inelastic, or alternatively the volumes that the company is buying/ selling are not large enough to influence the market price.

In each event node  $z$  where uncertainty is resolved in the scenario tree, we need to add non-anticipativity constraints (Rockafellar & Wets 1991). Let the scenarios passing through node  $z$  be given by  $S(z)$  and let  $T(z)$  be the time period of node  $z$ . Then we have the following constraints:

$$\frac{1}{|S(z)|} \sum_{s' \in S(z)} (d_{gts'}, q_{mts'}, f_{ijts'}, p_{its'}, c_{gts'}, p_{ijts'}^{avg}, LP_{ijts'}, q_{ijts'}^{in}) = \quad (4.26)$$

$$(d_{gts}, q_{mts}, f_{ijts}, p_{its}, c_{gts}, p_{ijts}^{avg}, LP_{ijts}, q_{ijts}^{in}), \quad z \in \mathcal{Z}, \quad s \in S(z), \quad t \in T(z).$$

The two models then consist of:

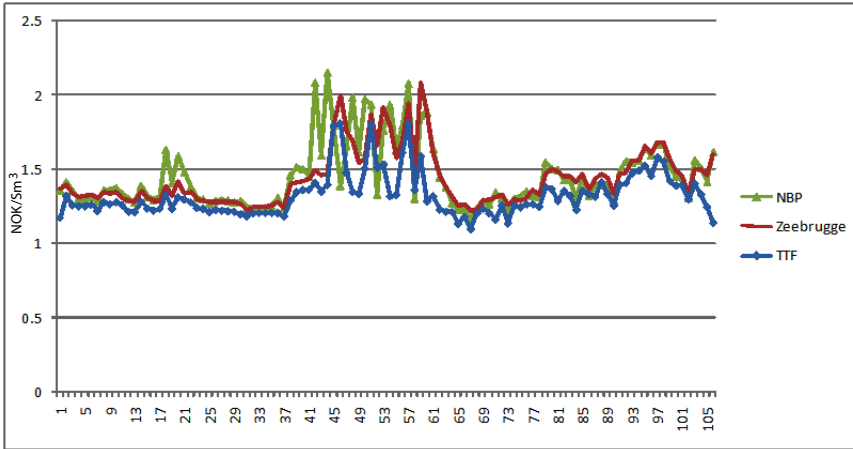
1. Model without line-pack: max (4.11) s.t. (4.7)-(4.14), (4.19)-(4.20), (4.22), (4.24), (4.26)
2. Model with line-pack: max (4.11) s.t. (4.7)-(4.13), (4.15)-(4.19), (4.21), (4.23), (4.17), (4.25)-(4.26).

## 4.4 Test case from the Norwegian continental shelf

The network chosen as a test case is shown in Figure 4.16. In the network there are three fields, two junction points and three market nodes. The transportation capacity of the pipelines is comparable to the dry-gas transportation system in the North-Sea, but the structure is simpler. The demand in the take-or-pay volumes are chosen to reflect the dominant position of these contracts in the North-Sea. The chosen market hubs are large hubs in Europe (Zeebrugge, NBP and TTF). In reality the Title Transfer Facility (TTF) hub is however not connected to the transportation system from the North-Sea. This market hub is included because of the liquidity of the market and the availability of price data as a substitute for less liquid spot markets in the Emden, Dornum and Dunkerque hubs.

## The spot markets

The price scenarios are generated based on time-series of historical observations. The price data was supplied by the Heren Energy Ltd. The price tends to be higher during winter than during summer. In addition to the seasonal variations, there are large upwards peaks in the time series. Being able to deliver extra quantities of gas when such a peak occurs is advantageous.



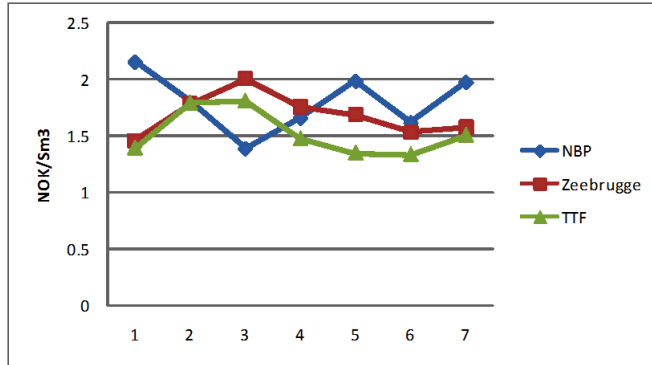
**Figure 4.8:** Prices at the three hubs in the winter period 2005.

In this article we focus on the winter season, which we define to be from October 1st to March 31st. The price series are illustrated in Figure 4.8. During the winter period, the prices are high and the flexibility in the network is low. During the summer season, the nominated quantities of the long-term contracts are lower and thus the flexibility is larger. The winter period thus requires careful planning, and the gain from good planning may be substantial. Figure 4.9 shows the weekly variation over 7 days, and illustrates that the price volatility within a week can be large.

Before constructing the prediction models for the time-series, the price peaks (defined as deviations of more than 50% of the average value) are considered as outliers and are therefore removed and replaced with the average value of the price on the same weekday in the previous and coming week.

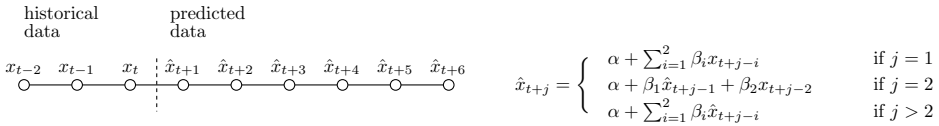
## Forecasting and scenario generation

In each node in the scenario-tree, there is a spot price and a take-or-pay volume for each of the market hubs (the method to construct scenarios for the take-or-



**Figure 4.9:** Illustration of the weekly variations in the last week of February 2005.

pay volumes is given in the next section). We use AR(2)-models to predict the spot price in all market nodes (see Figure 4.10).

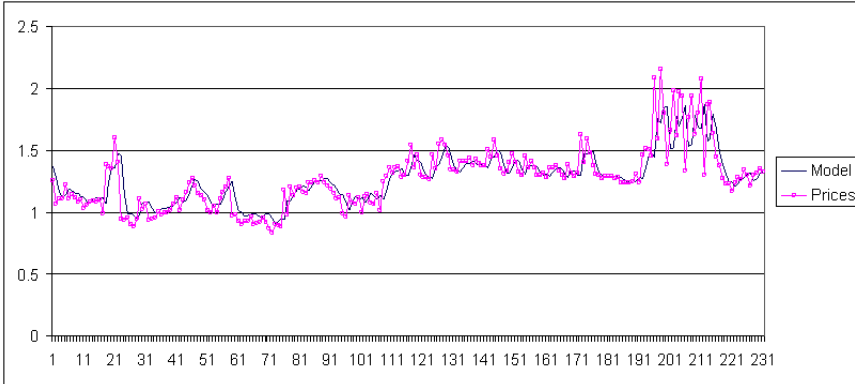


**Figure 4.10:** The AR(2) prediction model.

An example of how one of the AR(2)-models fits the real data is shown in Figure 4.11. The models seem to represent the time-series development reasonably good and are unbiased. This is important for the scenario generation method we have chosen. Such price models will in general track the real data process by following it closely but in general lag a bit behind downward and upward movements. The AR(2) model is parameterized so that the expected error is 0, and then the scenarios are there to describe the historical deviations from the forecast.

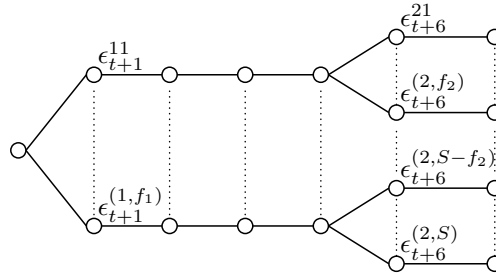
We estimate the first four moments (expectation, variance, skewness and kurtosis) and correlation of the prediction error distributions for the markets based on the historical data. We then use a moment matching procedure that was developed in Høyland et al. (2003) to generate our scenarios. Figure 4.12 shows an example of a scenario tree for the prediction error. The indexes  $f_1$  and  $f_2$  give the number of branches in the first and second stage, respectively. The value of  $\epsilon_t^{stage, branch}$  is zero in all nodes in the scenario tree, except for the nodes in the first period in a new stage (corresponding to period  $t+1$  and  $t+6$  in Figure 4.12).





**Figure 4.11:** Real prices and values obtained from the prediction model (here illustrated for the NBP).

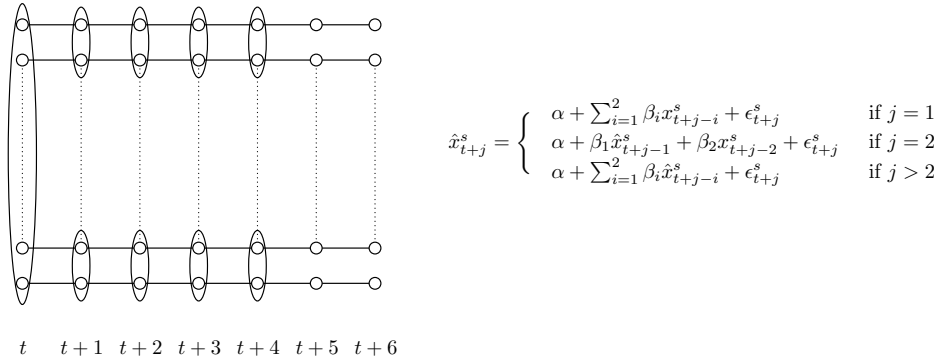
We generate  $S$  multivariate scenarios for the prediction error with the correct correlation between the markets and with correct moments for the individual error terms.



**Figure 4.12:** The scenario tree for the prediction errors.

Finally, we combine the AR(2) prediction model with the scenario tree for the prediction errors to one scenario tree. Each scenario presents a path from the root node to the leaf node (there are  $S$  unique paths through the tree). This is illustrated in Figure 4.13. The predicted values,  $\hat{x}_{t+j}$  can depend on both historical data and predicted data ( $\hat{x}_{t+2}$  for instance depends on both  $x_t$  and  $\hat{x}_{t+1}$ ) (see Figure 4.10). The value in each node in a path through the scenario tree can then easily be found by the formula shown in the figure. Hence we use the forecasting method to predict the expected price, and scenario generation to describe the variation (error) around this price.

An important issue in stochastic models is the information structure. The nonanticipativity constraints make sure that decisions at time  $t$  can only depend on information available at this time, see for example Ruszczyński (1997). We have implemented the nonanticipativity constraints in Equation (4.26). In Figure 4.13 the nonanticipativity constraints are represented by the ellipsoids.



**Figure 4.13:** All paths through the scenario tree. The ellipsoids represent the nonanticipativity equations.

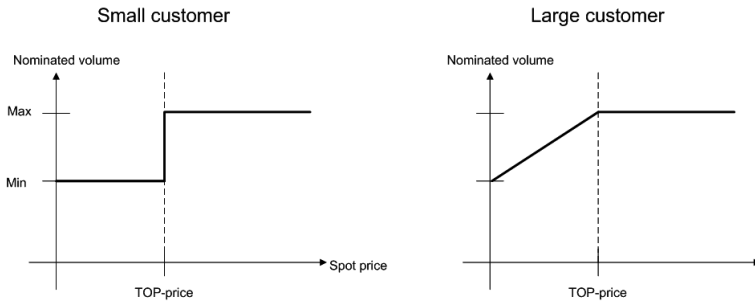
### Take-or-pay volumes

For the take-or-pay contracts, we assume that the company’s customers can be divided into two groups: Group 1 comprises gas purchasers with large delivery commitments in Europe. Group 2 contains purchasers that have more flexibility to utilize the TOP-contract as a call option.

The Group 2 customers will nominate the maximum amount given that the spot price exceeds the TOP-price (plus the transaction costs), and the minimal amount when the spot price is lower than the TOP-price.

For Group 1 we assume that the nominated volume is a linear function of the spot price within a certain range. This means that they will nominate a high volume given that the spot-price is high, and nominate a low volume in case of a low spot-price. The fluctuations in nomination is however less extreme than for Group 2. This is illustrated in figure 4.14.

A large percentage of the gas in the North-Sea is still sold through long-term contracts. We have reflected this in the model by choosing the expected demand in the take-or-pay contracts to be a large percentage of the total production capacity in the fields.



**Figure 4.14:** The two different customer types.

## The supply side

Most gas fields in the North-Sea produce both oil and gas. There are however eight pure gas fields. The total export of natural gas from Norway to Europe in 2005 were 82.5 billion  $Sm^3$ . In our model, we have included approximately 60% of this volume in a simplified network structure. The transportation network consists of long, subsea pipelines that are operated at high pressure. An overview of the production capacities and pipelines characteristics in the North-Sea can be found in OED (2006). Currently, as much as 90% of the gas is sold through long-term contracts. It is however expected that this amount will decrease, and that the trade in short-term markets will increase. In our case study the TOP-volume is in average 60% of the total production.

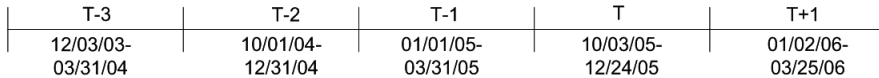
When running the model on a rolling horizon and implementing the first stage decisions (decisions for the first day), the model with line-pack may end with a line-pack inventory that is lower or higher than the starting level. In order to compare the models with and without line-pack, one has to assign a value to this line-pack difference. One option would be to use the price of gas at the last day in the test period for which the model is run, but since the prices are volatile this is an unstable method. Changes of one day in the length of the test period may have substantial effect on the overall return both in positive and negative direction in this case. Instead, we use the average price in the test period. We use two measures when comparing the results from the models: profit from the spot market (after the inventory value adjustment) and the average obtained price in the spot market. In the following, all gas volumes are given in million standard cubic meters and the profits are given in million Norwegian kroner (NOK).

Rolling horizon	Price Model 1 (PM1)		Price Model 2 (PM2)	
	$T$	$T + 1$	$T$	$T + 1$
AR(2)-parameters	$T - 3$	$T - 3, T - 2$	$T - 1$	$T$
Prediction errors	$T - 2, T - 1$	$T - 1, T$	$T - 1$	$T$

**Table 4.1:** Time periods used to estimate AR(2)-parameters and the prediction errors for our two price models.

### Test instances

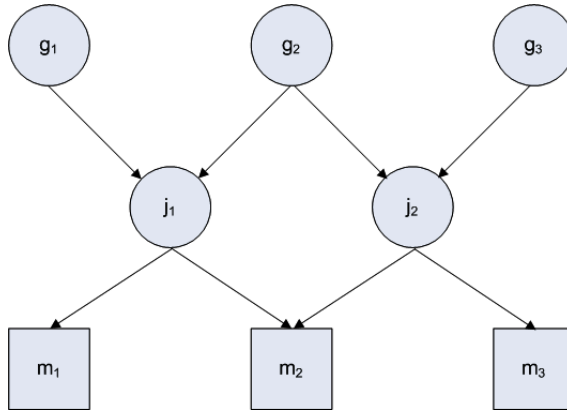
We have tested the model on real price data, with a rolling horizon over 60 planning days (72 calendar days). Figure 4.15 shows the two different time periods considered in this paper: October 3rd 2005 - December 24th 2005 (period  $T$ ) and January 2nd 2006 - March 25th 2006 (period  $T + 1$ ). We have used two different approaches for parameterizations of the price models. In PM1 we use two different time periods for the parameterization of the AR-model and for finding the error distribution. See Table 4.1 for an overview. In PM2 we use as recent data as possible and the same data for both the parameterization and the error estimation. In order to capture the effect of price peaks, we have in some of the cases introduced extreme scenarios: one scenario where the price is doubled and one scenario where the price is halved for the entire week. In addition, shorter fluctuations are added to some scenarios (doubling or halving of the price for one or more time periods). We have also tested the effect of updating the prediction errors on a monthly basis.



**Figure 4.15:** The time periods considered in this article.

## 4.5 Computational results and discussion

In order to ensure feasibility for all daily runs on the rolling-horizon, we introduce a penalty cost for not meeting the take-or-pay requirements on a given day, as well as for not being able to meet the line-pack-requirements. These penalty costs are necessary for the deterministic model; otherwise commitments from previous runs on the rolling horizon can lead to infeasible problems. The stochastic versions will most often have taken the possibility of a price increase into consideration. When comparing the results from the models, the penalty costs are not included.



**Figure 4.16:** The network considered in this paper.

## Perfect information

We start the analysis by looking at a situation where the producer knows the exact values for the price and TOP-volumes for the next seven days. The solution with this input data gives insight to the value of line-pack, as well as how the solution of the model depends on the starting level of the line-pack. This solution also gives a benchmark to compare the results of our model run with stochastic prices.

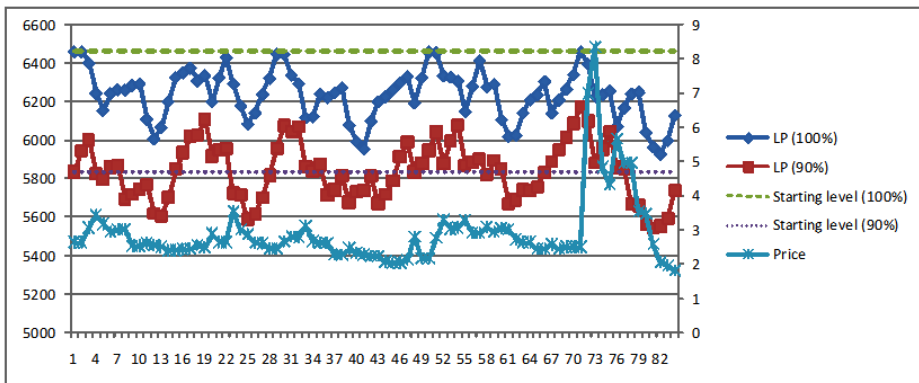
The results are presented in Table 4.2 (the models with line-pack are started with the pipelines filled to the capacity limit). As we can see from these results, the value of line-pack depends on which period we look at. For autumn 2005,  $T$ , the difference is 1.72%. For spring 2006 however, the difference is 13.97%. The price data for spring 2006 are much more volatile than for autumn 2005. As expected, the added volatility in the spot prices increases the value of the inherent flexibility in the line-pack.

We then look at the importance of the starting level of the line-pack in the system. In Figure 4.17 we have looked at a situation where we initiate the model with a line-pack level of 90%. In the figure, the resulting line-pack utilization is compared with a model where the starting level is at 100%.

As expected, both models show the same behavior: the line-pack increase in periods with low price and decrease in periods with high prices. The results from optimizing with the two different starting levels are shown in Table 4.3. In our test-case, the model with a starting line-pack level of 90% of total capacity has higher profits. The reason is that this model has higher flexibility with respect to storage utilization (the target level for line-pack at the end of the week is at least 90% which is a weaker requirement). We get an improved income from the

Time period	Case 1 $T$	Case 2 $T$
Model type	With line-pack	Without line-pack
Spot market income	14573.94	14205.71
Average price	2.388	2.388
Average obtained price	2.927	2.833
Adjusted with average price	14450.40	14205.71
Time period	Case 3 $T + 1$	Case 4 $T + 1$
Model type	With line-pack	Without line-pack
Spot market income	18806.26	15994.74
Average price	2.927	2.927
Average obtained price	3.777	3.344
Adjusted with average price	18228.61	15994.74

**Table 4.2:** Spot market income for the optimization model run with perfect information.



**Figure 4.17:** Utilization of line-pack in the network for the model with perfect information (spring 2006).

spot market of 4.0%.

Generally, we can conclude that on a fixed horizon it is beneficial to start with a high level of line-pack and have a low target level at the end-of-horizon. When the start- and target-level are the same, a high inventory requirement is not necessarily beneficial.

	Case 5	Case 6
Time period	$T + 1$	$T + 1$
Line-pack start level	100%	90%
Spot market income	18806.26	18816.68
Average price	2.927	2.927
Average obtained price	3.777	3.978
Adjusted with average price	18228.61	18968.62

**Table 4.3:** Results when running the model with different starting line-pack levels.

## Stochastic versus deterministic models

In the following we compare the results of the stochastic model based on forecasting and scenario generation with the deterministic model based on forecasting alone. We use the perfect information case as a benchmark. The stochastic version uses 900 scenarios to describe price uncertainty in the 3 markets for the next 7 days. We tested the different combinations of parameter estimations and error estimations described in Section 4.4. For each of the instances, we present aggregated profit from both time periods. The results for PM1 are shown in Table 4.4. The largest difference between the stochastic and deterministic version is found for the model including line-pack. The difference is here 4.64%, while the difference is 0.41% for the model without line-pack. The difference up to the benchmarks for these models are however large (11.12% and 5.72% for the stochastic models).

We then added extreme scenarios to the stochastic model, as well as the option to update the distribution of prediction errors on a monthly basis. The best result for the model with line-pack was achieved when only adding outliers, the distance to the benchmark was 7.94% and the value was 7.05% larger than the result for the deterministic model. For the model without line-pack, the best combination turned out to be using both outliers and monthly update of the prediction error. The distance to the benchmark for this result was 4.76%, and the result was 2.34% larger than the deterministic model.

Further, we estimated the AR(2)-models and prediction errors on the winter period most recent to the rolling horizon using PM2. The results are given in

Price model	Case 7	Case 8
Model type	PM1	PM1
Uncertainty	With line-pack	With line-pack
Spot market income	Stochastic	Deterministic
Average obtained price	30317.06	30199.84
Average price	3.022	2.882
Adjusted with average price	2.658	2.658
	29408.23	28104.57
Price model	Case 9	Case 10
Model type	PM1	PM1
Uncertainty	Without line-pack	Without line-pack
Spot market income	Stochastic	Deterministic
Average obtained price	28566.24	28450.87
	2.946	2.934

**Table 4.4:** Comparison of the deterministic and stochastic model with and without line-pack. The results are aggregated for  $T$  and  $T + 1$ .

Table 4.5. As we can see from these tables, the stochastic models still give better results than the deterministic models, but the difference has decreased. For the model with line-pack, the difference is now 0.52%, while for the model without line-pack the difference is almost zero (0.013%). The distance to the benchmark is now, respectively, 7.1% and 5.5%. We see that the distance to the benchmark has decreased for the model with line-pack, but actually increased for the model without line-pack.

Again, we introduce outliers as well as monthly updates of the prediction error. For the model with line-pack, the best result is obtained when the prediction error is updated monthly. The change is however quite small - the distance to the benchmark solution is 7.07% and the distance to the deterministic solution is 0.56%. For the model without line-pack, the best solution was also achieved when the prediction error was updated monthly. The distance to the benchmark solution was now 5.36% and the distance to the deterministic solution was 0.21%.

The difference between the models with and without line-pack is quite clear in all our results. If we compare the best models with line-pack (PM2, monthly updated error distribution) with the best model without line-pack (PM1, extreme scenarios and monthly updated error distributions) we get an advantage of 5.6%, or 1607 million NOK. For the benchmark models, the same comparison gave a difference of 8.21%.

The difference between the stochastic models and the deterministic version is less clear. Still, the stochastic version is consistently outperforming the deter-



Price model	Case 11 PM2	Case 12 PM2
Model type	With line-pack	With line-pack
Uncertainty	Stochastic	Deterministic
Spot market income	30934.25	30795.71
Average obtained price	3.126	3.108
Average price	2.658	2.658
Adjusted with average price	30355.84	30199.84
Price model	Case 13 PM2	Case 14 PM2
Model type	Without line-pack	Without line-pack
Uncertainty	Stochastic	Deterministic
Spot market income	28525.01	28521.45
Average obtained price	2.942	2.941

**Table 4.5:** Comparison of the deterministic and stochastic model with and without line-pack. The results are aggregated for  $T$  and  $T + 1$ .

ministic version. For some combinations of parameter and error estimation we gain a lot from using the stochastic model. The largest difference is found for Price Model 1 in spring 2006, the stochastic solution is 12.84% larger than the deterministic solution in this case. The stochastic model seems to be more robust than the deterministic model when it comes to choice of parameters and time period for error estimation. Also we observed that the deterministic model has positive values for the penalty functions in some cases, indicating that the line-pack end-of-horizon constraints were violated. This did not happen for any of the stochastic models.

When we initiated the system with 90% line-pack level, the results were clearly inferior to the models started with 100% line-pack level. This result indicates that the price models are not accurate enough to utilize the added flexibility from the reduced target storage.

## 4.6 Conclusions

We present a stochastic portfolio optimization model for operational planning in natural gas value chains. We compare the results from the model both with and without storage in the pipelines and with and without stochasticity (prices and TOP-quantity). We have used real market prices, and tested the model on two time periods: fall 2005 and spring 2006.

The results show that modelling storage in the model can increase the prof-

itability of the system substantially when operated optimally. With perfect information, the added profits were as high as 13.97% for the 60-day period in spring 2006. This indicates a large commercial value of actively using the storage inherent in the pipelines (line-pack) to maximize profits.

We have also seen that taking into account the stochasticity in the problem can, in some instances, lead to large gains in the objective function value. In addition, the deterministic model was infeasible for some days on the rolling-horizon (not able to deliver in TOP-contracts and/or not able to meet the target level for line-pack) for some of the tests we did. We also found that the results from the deterministic model were more sensitive to the value of the parameters in the prediction model than the results from the stochastic model.

There are many possible extensions of this work. Firstly, it would be interesting to compare the results from this model with a transient flow model. With a transient flow model, also shorter time periods (such as hours) could be considered. Secondly, market power in some, or all, hubs could be introduced (with uncertainty in the price elasticity in the markets). Thirdly, we can relax the system perspective on the value-chain, and see how the inclusion of one or more producers would influence the results.

## Bibliography

- Byers, J. W. (2006), 'Commodity storage valuation: A linear optimization based on traded instruments', *Energy Economics* **28**, 275–287.
- Campbell, J. (1992), *Gas Conditioning and Processing: The Equipment Modules*, John M. Campbell & Company, Norman, Oklahoma, USA.
- Dahl, H. J. (2001), Norwegian Natural Gas Transportation Systems. Operations in a Liberalized European Gas Market, PhD thesis, NTNU, Trondheim, Norway.
- Gabriel, S. A., Zhuang, J. & Kiet, S. (2005), 'A large-scale complementarity model of the North American natural gas market', *Energy Economics* **27**, 639–665.
- Gabriel, S. & Smeers, Y. (2005), 'Complementarity problems in restructured natural gas markets', CORE Discussion Paper No. 2005/37.
- Goel, V. & Grossmann, I. E. (2004), 'A stochastic programming approach to planning of offshore gas field developments under uncertainty in reserves', *Computers & Chemical Engineering* **28**, 1409–1429.
- Haugen, K. K. (1996), 'A stochastic dynamic programming model for scheduling of offshore petroleum fields with resource uncertainty', *European Journal of Operational Research* **88**, 88–100.
- Høyland, K., Kaut, M. & Wallace, S. W. (2003), 'A heuristic for moment-matching scenario generation', *Computational Optimization and Applications* **24**(2-3), 169–185.
- Iyer, R. R., Grossmann, I. E., Vasantharajan, S. & Cullick, A. S. (1998), 'Optimal planning and scheduling of offshore oil field infrastructure investment and operations', *Ind. Eng. Chem. Res.* **37**, 1380–1397.
- Kall, P. & Wallace, S. W. (1994), *Stochastic Programming*, John Wiley & Sons, Chichester.
- Katz, D. & Lee, R. (1990), *Natural Gas Engineering*, McGraw-Hill, New York, USA.

- Kelling, C., Reith, K. & Sekirnjak, E. (2000), A practical approach to transient optimization for gas networks, Technical report, PSIG.
- Martin, A., Möller, M. & Moritz, S. (2006), ‘Mixed integer models for the stationary case of gas network optimization’, *Mathematical Programming* **105**(2-3), 563–582.
- Midthun, K. T., Bjørndal, M., Smeers, Y. & Tomasgard, A. (2007), Capacity booking in a transportation network with stochastic demand and a secondary market for transportation capacity. Working paper at NTNU, Trondheim, Norway.
- Midthun, K. T., Bjørndal, M. & Tomasgard, A. (2006), Modeling optimal economic dispatch and flow externalities in natural gas networks. Working paper, NTNU, Trondheim, Norway. Submitted to international journal.
- Modisette, J. L. (2000), Equation of state tutorial, Technical report, PSIG.
- Nørstebø, V. S. (2004), Modeling short term planning in natural gas networks (in Norwegian), Master’s thesis, NTNU, Trondheim, Norway.
- Nowak, M. (2006), Compressor approximation. Working paper, NTNU, Trondheim, Norway.
- Nowak, M. & Westphalen, M. (2003), A linear model for transient gas flow, in ‘Proceedings of ECOS’, pp. 1751–1758. available as SINTEF-report STF 38S03601, Trondheim, Norway.
- Nygreen, B., Christiansen, M., Bjørkvoll, T., Haugen, K. & Kristiansen, Ø. (1998), ‘Modelling norwegian petroleum production and transportation’, *Annals of Operations Research* **82**, 251–267.
- OED (2006), ‘Fakta norsk petroleumsværksemnd 2006’.
- Osiadacz, A. (1983), ‘Optimal numerical method for simulating dynamic flow of gas in pipelines’, *International Journal for Numerical Methods in Fluids* **3**, 125–135.
- Rømo, F., Tomasgard, A., Fodstad, M., Hellemo, L. & Nowak, M. (2007), An optimization system for gas transportation on the norwegian continental shelf. Working paper, NTNU, Trondheim, Norway.
- Rockafellar, R. T. & Wets, R. J.-B. (1991), ‘Scenarios and policy aggregation in optimization under uncertainty’, *Mathematics of Operations Research* **16**, 119–147.

- 
- Ruszczynski, A. (1997), ‘Decomposition methods in stochastic programming’, *Mathematical Programming* **79**, 333–353.
- Selot, A., Kuok, L. K., Robinson, M., Mason, T. L. & Barton, P. I. (2007), A short term operational planning model for upstream natural gas production systems. to appear in *AIChE Journal*.
- Streeter, V. L. & Wylie, E. B. (1970), ‘Natural gas pipeline transients’, *Society of Petroleum Engineers Journal*, **December**, 357–364.
- Thompson, M., Davison, M. & Rasmussen, H. (2003), Natural gas storage valuation and optimization: A real options approach. Working paper, University of Western Ontario, Canada.
- Tomasgard, A., Rømo, F., Fodstad, M. & Midthun, K. (2007), Optimization models for the natural gas value chain, in G. Hasle, K.-A. Lie & E. Quak, eds, ‘Geometric Modelling, Numerical Simulation, and Optimization: Applied Mathematics at SINTEF’, Springer, chapter Optimization Models for the Natural Gas Value Chain.
- Ulstein, N., Nygreen, B. & Sagli, J. (2007), ‘Tactical planning of offshore petroleum production’, *European Journal of Operational Research* **176**, 550–564.
- Van der Hoeven, T. (2004), Math in Gas and the Art of Linearization, PhD thesis, International business school and research center for natural gas, Groningen, The Netherlands.
- Westphalen, M. (2004), Anwendungen der Stochastischen Optimierung im Stromhandel und Gastransport, PhD thesis, University Duisburg-Essen (Germany).
- Zhuang, J. & Gabriel, S. (2006), A complementarity model for solving stochastic natural gas market equilibria. January 2006, *Energy Economics*, accepted.



## Paper IV

Kjetil T. Midthun, Mette Bjørndal, Asgeir Tomasgard and Yves Smeers:

### *Capacity booking in a Transportation Network with stochastic demand and a secondary market for Transportation Capacity*





## Chapter 5

# Capacity booking in a Transportation Network with stochastic demand and a secondary market for Transportation Capacity

### **Abstract:**

We present an equilibrium model for transport booking in a gas transportation network. The booking regime is similar to the regime implemented in the North-Sea. The model looks at the challenges faced by the network operator in regulating such a system. There are some privileged players in the network, with access to a primary market for transportation capacity. The demand for capacity is stochastic when the booking in the primary market is done. There is also an open secondary market for transportation capacity where all players participate including a competitive fringe. We consider different objective functions for the network operator, and the difference between setting fixed capacities and modeling the pressure constraints in a sub-sea pipeline-network. This is modelled as a Generalized Nash Equilibrium using a stochastic complementarity problem.

## 5.1 Introduction

We study booking of transportation capacity in a natural gas network with several large players and a competitive fringe. The offshore pipeline system in the North-Sea provides a case for our analysis, but the model and results are interesting for natural gas transportation in general. There are two booking stages in the transport capacity market. In the first stage the large producers book capacity within their predefined capacity rights. In the second stage there is a redistribution of capacity in a bilateral secondary market, where also the competitive fringe participates. Here the network operator can sell remaining capacity in the system, and capacity bought in the first-stage primary market can be sold by the producers.

The purpose of the paper is to develop a model that can be used to analyze how different objective functions for the system operator affect the efficiency of the transportation system. We also investigate the effect of using different model

representations of the physical properties of the transport network. Another interesting topic is how stochasticity in the price for natural gas influences our results. The model is based on Generalized Nash Equilibrium and is represented as a stochastic complementarity problem. To our knowledge this is the first time the booking system for natural gas transportation is studied using this approach.

The network operator influences the efficiency in the network through the routing. The routing decisions will also determine the capacity sold in the secondary market. This is different from the role of the network operator compared to the articles studying electricity networks, by for instance Yao et al. (2004) and Hu et al. (2004) where the network operator choose the production from each producer in order to maximize social surplus. In the North-Sea, the network operator acts as a neutral third party.

We formulate the model as a mixed complementarity problem, see for example Ferris & Pang (1997) and Facchinei & Pang (2003). A path-breaking paper for the use of complementarity problems modelling economic equilibrium was Lemke & Howson (1964). In the energy sector there are numerous examples of papers using complementarity problems to model and solve economic equilibria. Gabriel, Zhuang & Kiet (2005) presents a linear complementarity equilibrium model for the North American natural gas market. Gabriel, Kiet & Zhuang (2005) presents a multi-seasonal, multiyear mixed nonlinear complementarity problem of natural gas markets. Smeers (2003*a*) and Smeers (2003*b*) discuss the deregulation of the electricity markets and the organization of regional electricity transmission. In Jing-Yuan & Smeers (1999) spatial oligopolistic electricity models are given and Generalized Nash Equilibria are found in a system with Cournot generators and regulated transmission prices. Yao et al. (2006) presents a model of two-settlement electricity markets using an Equilibrium Problems with Equilibrium Constraints (EPEC). Hu et al. (2004) model strategic bidding by generators to an ISO that is maximizing social surplus. The loop flow is taken into consideration and shown to be important for the results. The model is an EPEC solved as an All-KKT system in PATH. Hobbs (2001) presents Cournot models of bilateral power markets.

In Section 5.2 we discuss the background for this article, as well as the assumptions we have made. The model formulation as a stochastic Mixed Complementarity Problem is presented in Section 5.3. A more detailed description of the equilibrium conditions is given in Appendix 5.A. The properties of the model are discussed in Section 5.4. We then move on to some numerical examples in Section 5.5. Finally, the conclusions are given in Section 5.6.

## 5.2 Problem description and assumptions

We present here the ideas and motivation for our case analysis, the assumptions we have made and the reason for introducing them.

### System in the North-Sea

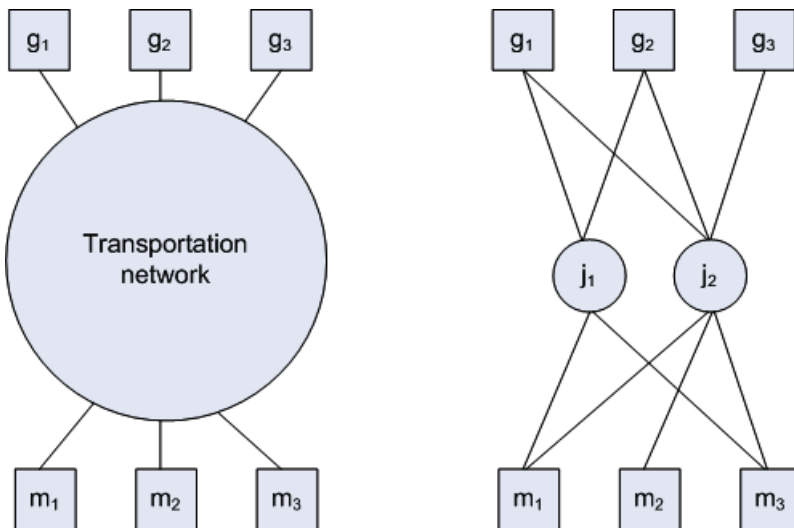
We study a system with field nodes, each with a set of large producers in addition to a competitive fridge. The producers deliver natural gas into a transportation network passing through junction nodes and ending in market nodes. The market for capacity in this network is managed by an independent system operator (ISO) named Gassco. The producers book transport capacity from field to market and can not determine the actual routing of the gas through the network. The routing is the responsibility of the ISO. The image on the left in Figure 5.1 illustrates the point-to-point perspective of the producers. The transportation network can be considered as a black box for the producers. The system operator operate the network taking into account the details in the network, as illustrated in the image on the right in Figure 5.1.

At the Norwegian Continental Shelf (NCS) capacity distribution is done in a primary market, and the remaining capacity after this initial distribution is handled through a secondary market. In the secondary market, both transactions of capacity facilitated by the ISO and bilateral transactions between shippers are included. The secondary market is open to all qualified shippers. Only the large producers book capacity in the primary market limited by predefined capacity rights. This booking right depends on their need to transport induced by the TOP contracts. The actual demand for capacity due to the TOP contracts is uncertain until delivery. In sum, the available capacity in the primary market is actually larger than the total capacity in the network. If a conflict arises with respect to over-booking, a capacity allocation key is used to resolve these matters. We have not explicitly modeled this rule in this paper.

In addition to the long term contracts for gas in the markets nodes, there are short-term markets where gas may be sold. In this article we have assumed that the producers may act strategically in the transport capacity market, but that they are price-takers in the spot markets in the market nodes. This is reasonable as Norway's overall production is around 15% of the European consumption of natural gas. The main market hubs are in UK, Germany, France and Belgium. In the market hubs there are large buyers of natural gas who distribute the gas further to either the suppliers or end-customers. In our model, the analysis ends at the market hubs. For details regarding the liberalization of the European gas market see European Union (1998) and European Union (2003), and for details on the Norwegian case, see Austvik (2003).

The purpose of our model is mainly to analyze the effect different objectives of the ISO will have on the operation of the system. The price the ISO can take is regulated and fixed both in the primary and in the secondary market, so its decision variables are only routing and secondary market sales of available capacity. If we represent the ISO with a feasibility problem, the corresponding game will have an infinite amount of equilibria. For each choice of secondary market sales from the ISO, a solution satisfying the large producers' equilibrium conditions can be found. Hence we focus on the following alternatives: max flow, max value of flow and max social surplus. In the following we assume that the ISO does not have economic interests in the routing, and acts as a benevolent central planner.

We also investigate how the representation of the physical networks as well as the booking rights in the primary markets will influence the efficiency of the network.



**Figure 5.1:** The field nodes are denoted by  $g$ , junction nodes by  $j$  and market nodes by  $m$ . The gas flows from top to bottom.

## Second-stage decision structure

Our model is a one level game where each of the producers decision problem is a stochastic two-stage program with recourse (Kall & Wallace 1994). The stochastic elements are the spot price in the markets and the quantity in the

TOP-contracts. The uncertainty is modeled with scenarios (see Figure 5.3). The decisions in the two stages are illustrated in Figure 5.2.

In the secondary market (in the second stage) we assume that the large producers and the competitive fringe make simultaneous volume decisions in a Cournot manner. Each of the large producers recognizes that they will influence the price for transportation capacity, but make independent volume decisions. The players in the competitive fringe are price takers in the capacity market. Their reaction function is expressed as their demand for transportation capacity at a given transportation price. This demand is positive as long as the market price for natural gas in a market hub is higher than the marginal production cost for the competitive fringe in a field node plus the transportation price from that node to the market.

Further, we assume that the ISO's decisions are made simultaneously with the producers. Hence, the ISO is a Cournot player whose volume decisions cannot be manipulated by other players strategically. An alternative would be to model this as a multi-leader one-follower Stackelberg game (Yao 2006) with the ISO as a follower. A common way of modeling this follower situation, when the ISO has a convex optimization problem, is by including the KKT-conditions for the ISO's routing and capacity release in the other players' optimization problem. They will then act strategically because they anticipate the ISO's reaction to their own volume decisions. In this case each player solves a mathematical program with equilibrium constraints (MPEC, Luo et al. (1996)) and the resulting game over all the players become an EPEC. In our approach we stay within the framework of Mixed Complementarity Problems as all decisions are simultaneous, and a common way of modeling this is to merge all the players KKT-conditions into a large complementarity system. We think that the setting with simultaneous decisions is closer to the reality of the Norwegian continental shelf. Firstly, the players are not supposed to act strategically, for example in terms of influencing the ISO in the transportation market. Secondly, the other players never know or get information about the ISO's routing decisions. This is confidential information, and so are the booking requests, sales and production volumes of the other players.

## First-stage decision structure

In the first stage each of the large producers decides on a booking volume. This booking decision is based on maximizing the expected revenue for the second stage where production and transportation strategies are made as well as trades in the secondary market for transportation capacity.

We assume that each player makes his first-stage decisions and his second-stage decisions simultaneously. In practice this means that the second-stage decisions

will depend on the outcomes of the stochastic variables, but the contingent strategy covering all possible outcomes is made before the player observes the other players booking. Each producer's optimization problem is then a stochastic two-stage program with recourse, given the other players fixed decisions. The overall problem is still a Mixed Complementarity Problem, often called a Stochastic Mixed Complementarity Problem because of the stochastic variables and two-stage structure.

If, on the other hand the booking decisions had been used strategically by the players, we would need to include the second-stage equilibrium over all the players as a part of the booking problem in the first stage for each player. Normally this is done by including the KKT-conditions from the second stage equilibrium in each player's first-stage optimization problem. In such a setting each player's problem would be a stochastic MPEC, where the second-stage equilibrium conditions for each scenario is part of the first-stage optimization problem and parameterized on the first stage decisions (Patriksson & Wynter 1999).

When the first- and second-stage decisions are made simultaneously we model the situation where either a player does not know the other players' booking decisions when he makes his second-stage decisions, or he has this booking information but does not let it influence his second stage decisions. In the Norwegian regime with a confidential booking process, we feel that this is a sound model. Then the only information revealed (or acted on) between the first and second stage is the uncertainty that is resolved. This is a one level game as the scenarios are independent of the first-stage decisions.

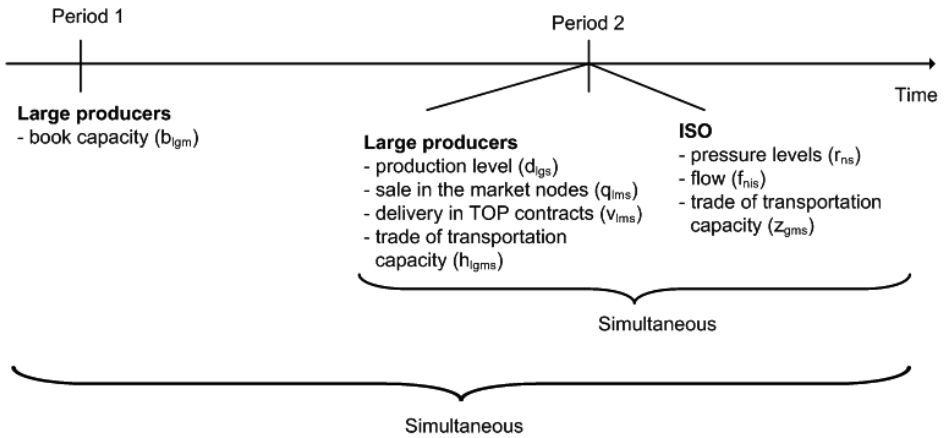
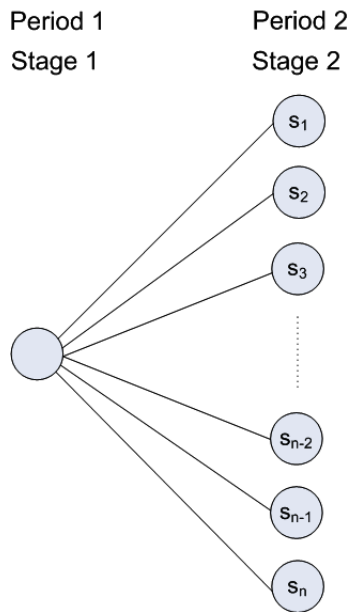


Figure 5.2: The sequencing of decisions.



**Figure 5.3:** The scenario structure in the large producers' decision problem

## 5.3 Model

We start by introducing the notation. We then move on to a discussion of the price of transportation capacity in the secondary market. The networks we present are connected graphs.

### Notation

#### Sets

$\mathcal{N}$	The set of all nodes in the network.
$\mathcal{G}$	The set of field nodes in the network.
$\mathcal{J}$	The set of junction nodes in the network.
$\mathcal{M}$	The set of market nodes in the network.
$\mathcal{I}(n)$	The set of nodes with pipelines going into node $n$ (predecessor nodes).
$\mathcal{O}(n)$	The set of nodes with pipelines going out of node $n$ (successor nodes).
$\mathcal{L}$	The set of large producers in the network.
$\tilde{\mathcal{L}}_g$	The set of all producers in field $g$ (including the competitive fringe).
$\mathcal{S}$	The set of scenarios.

#### Indexes

$n$	Used for nodes in general.
$g$	Index for field nodes.
$j$	Index for junction nodes.
$m$	Index for market nodes.
$s$	Scenario index.
$l$	The index used for producers.



**Constants**

$\bar{R}_n$	The maximum pressure in node $n$ .
$\underline{R}_n$	The minimum pressure in node $n$ .
$K_{ij}$	The Weymouth constant for the pipeline going from $i$ to $j$ .
$B_{lgm}$	Booking limit for producer $l$ from field $g$ to market $m$ .
$P_{lm}$	Price in the long term contracts for producer $l$ in market $m$ .
$T_{gm}$	Per unit tariff for transportation between field $g$ and market $m$ .
$\overline{MC}_g$	Aggregated marginal cost parameter in field $g$ .
$\bar{C}_{ni}$	Capacity in the pipeline between node $n$ and $i$ .
$c_g$	Parameter in the cost function for the competitive fringe in field $g$ .
$c_{lg}$	Parameter in the cost function for producer $l$ in field $g$ .

**Decision variables**

$b_{lgm}$	Booking in the primary market by producer $l$ between field $g$ and market $m$ .
$d_{lgs}$	Production in field $g$ by producer $l$ in scenario $s$ .
$q_{lms}$	Spot sale in market $m$ by producer $l$ in scenario $s$ .
$h_{lgms}$	Capacity between $g$ and $m$ traded by producer $l$ in the secondary market in scenario $s$ .
$f_{nis}$	The flow between node $n$ and $i$ in scenario $s$ .
$r_{ns}$	The pressure in node $n$ in scenario $s$ .
$z_{gms}$	Capacity sold by the ISO in the secondary market between field $g$ and market $m$ in scenario $s$ .
$t_{gms}$	Price of transportation capacity between field $g$ and market $m$ in scenarios $s$ .
$x_{gms}$	Quantity produced in field $g$ and sold in market $m$ in scenario $s$ by the competitive fringe.

**Stochastic variables and probabilities**

$v_{lms}$	Nomination in long-term contracts in market $m$ .
$p_{ms}$	Spot price in market $m$ .
$\phi_s$	Probability of a given scenario.

**Functions**

$C_{lg}(d)$	The cost function for producer $l$ in field $g$ .
$W_g(y)$	Cost function for the competitive fringe in field $g$ .

## Price of capacity in the secondary market

The price in the secondary market in a node is given by a demand function from the competitive fringe in that node. We assume that the competitive fringes in the different field nodes are independent. The competitive fringe's demand function for transportation capacity between field  $g$  and market  $m$  in scenario  $s$  is then found from the profit maximization problem for the competitive fringe in field  $g$ :

$$\Pi_{gs} = \max \sum_{m \in \mathcal{M}} (p_{ms} \cdot x_{gms} - t_{gms} \cdot x_{gms}) - W_g \left( \sum_{m \in \mathcal{M}} x_{gms} \right), \quad (5.1)$$

where  $x_{gms}$  is the quantity traded in spot market  $m$  by the competitive fringe in field  $g$  in scenario  $s$ ,  $t_{gms}$  is the price of transportation capacity between  $g$  and  $m$  in the secondary market in scenario  $s$ .  $W_g$  is the cost function in field  $g$ . In order to find the demand function for the competitive fringe, the first order condition for optimality is used:

$$\frac{\partial \Pi_{gs}}{\partial x_{gms}} = p_{ms} - t_{gms} - \frac{\partial W_g \left( \sum_{m \in \mathcal{M}} x_{gms} \right)}{\partial x_{gms}} = 0, \quad g \in \mathcal{G}, m \in \mathcal{M}, s \in \mathcal{S}. \quad (5.2)$$

In this article, we assume that  $W_g$  is a quadratic function. For ease of presentation, we will in the following assume that the cost function for the competitive fringe is:

$$W_g \left( \sum_{m \in \mathcal{M}} x_{gms} \right) = \frac{1}{2} c_g \cdot \left( \sum_{m \in \mathcal{M}} x_{gms} \right)^2 \quad (5.3)$$

where  $c_g$  is the cost parameter for the competitive fringe in field  $g$ . Nevertheless, all results are valid for general quadratic cost functions (and most for a general cost function).

We model this implicitly in the large producers' problem as an elastic demand function. The inverse demand function is given as:

$$t_{gms} = p_{ms} - c_g \cdot \sum_{m' \in \mathcal{M}} x_{gm's}, \quad g \in \mathcal{G}, m \in \mathcal{M}, s \in \mathcal{S}. \quad (5.4)$$

The volume bought by the competitive fringe,  $x_{gms}$  is given as the sum of capacities sold by the ISO,  $z_{gms}$ , and the large producers,  $h_{lgms}$ . The  $h_{lgms}$  variable is positive when the large producers sell capacity, and negative if the large producers buy capacity. We then have the following relation between  $x_{gms}$ ,  $z_{gms}$  and  $h_{lgms}$ :

$$x_{gms} = z_{gms} + \sum_{l \in \mathcal{L}} h_{lgms}, \quad g \in \mathcal{G}, \quad m \in \mathcal{M}, \quad s \in \mathcal{S}, \quad (5.5)$$

which leads to the following expression for the price in the secondary market:

$$t_{gms} = p_{ms} - c_g \cdot \left( \sum_{m' \in \mathcal{M}} \left( z_{gm's} + \sum_{l \in \mathcal{L}} h_{lgm's} \right) \right), \quad g \in \mathcal{G}, \quad m \in \mathcal{M}, \quad s \in \mathcal{S}. \quad (5.6)$$

Since we only allow flow in one direction in our network, we need to make sure that  $x_{gms}$  cannot be negative.

$$z_{gms} + \sum_{l \in \mathcal{L}} h_{lgms} \geq 0, \quad g \in \mathcal{G}, \quad m \in \mathcal{M}, \quad s \in \mathcal{S}, \quad (5.7)$$

where  $h_{lgms}$  is the secondary market trades of producer  $l$  of capacity from  $g$  to  $m$ . The inclusion of this constraint means that the decision space for each producer depends on the other participants decisions (the other producers and the ISO).

## The large producers

The income for the large producers ( $\mathcal{L}$ ) in the network comes from deliveries in the long term contracts, sales in the spot markets and sales in the secondary market for transportation capacity. The cost for the producers come from the per unit tariff paid in the primary market for transportation capacity (which we assume is independent of the large producers' decisions), the cost of production and from purchasing additional transportation capacity in the secondary market. The objective function for producer  $l$  can be formulated as:

$$\begin{aligned} \Pi_l = & \max - \sum_{g \in \mathcal{G}} \sum_{m \in \mathcal{M}} T_{gm} b_{lgm} + \sum_{s \in \mathcal{S}} \phi_s \left[ \sum_{m \in \mathcal{M}} (p_{ms} q_{lms} + P_{lm} v_{lms}) \right] \\ & + \sum_{s \in \mathcal{S}} \phi_s \left[ \sum_{g \in \mathcal{G}} \sum_{m \in \mathcal{M}} h_{lgms} \cdot \left( p_{ms} - c_g \cdot \left( \sum_{m' \in \mathcal{M}} \left( z_{gm's} + \sum_{l' \in \mathcal{L}} h_{l'gm's} \right) \right) \right) \right] \\ & - \sum_{s \in \mathcal{S}} \phi_s \left[ \sum_{g \in \mathcal{G}} C_{lg}(d_{lgs}) \right], \end{aligned} \quad (5.8)$$

where  $b_{lgm}$  is the booking in the primary market,  $T_{gm}$  is the tariff in the primary market,  $\phi_s$  is the probability of scenario  $s$ ,  $p_{ms}$  is price in the spot market,  $q_{lms}$

is volume sold in the spot market,  $P_{lm}$  is the price in the take-or-pay contracts,  $v_{lms}$  is the volume in the take-or-pay contracts,  $h_{lgms}$  is the capacity traded in the secondary market (positive when the producer sell capacity, negative when he buys), the price in the secondary market is given by (5.6),  $C_{lg}$  is the cost function for the producer and  $d_{lgs}$  is the production.  $z_{gms}$  is the capacity sold by the ISO in the secondary market.

The booking constraint in the primary market is given as:

$$b_{lgm} \leq B_{lgm}, \quad g \in \mathcal{G}, \quad m \in \mathcal{M}, \quad (5.9)$$

where  $B_{lgm}$  is the fixed upper limit on booking for the producer. For the second stage the following constraints are needed:

$$d_{lgs} = \sum_{m \in \mathcal{M}} (b_{lgm} - h_{lgms}), \quad g \in \mathcal{G}, \quad s \in \mathcal{S}, \quad (5.10)$$

$$q_{lms} + v_{lms} = \sum_{g \in \mathcal{G}} (b_{lgm} - h_{lgms}), \quad m \in \mathcal{M}, \quad s \in \mathcal{S}, \quad (5.11)$$

$$h_{lgms} \leq b_{lgm}, \quad g \in \mathcal{G}, \quad m \in \mathcal{M}, \quad s \in \mathcal{S}, \quad (5.12)$$

$$z_{gms} + \sum_{l \in \mathcal{L}} h_{lgms} \geq 0, \quad g \in \mathcal{G}, \quad m \in \mathcal{M}, \quad s \in \mathcal{S}. \quad (5.13)$$

Constraint (5.10) make sure that the producer has booked enough capacity for the production in field  $g$ . Constraint (5.11) make sure that the producer has booked enough capacity for the total sale in market  $m$ . The two constraints also make sure that the producer utilizes all the booked capacity. Constraint (5.12) makes sure that the producer cannot sell more capacity than he has booked in the primary market, and constraint (5.13) ensures that the producers cannot buy more capacity than the ISO sells.

## Independent system operator

We present three different objective function alternatives for the ISO:

- maximize flow (MF):

$$\Pi_s^{MF} = \max \sum_{m \in \mathcal{M}} \sum_{i \in \mathcal{I}(m)} f_{ims}, \quad (5.14)$$

The network operator will always choose  $z_{gms}$  in order to maximize the flow under the constraint that all prices (for field-market combinations) must be positive (see Equation (5.26)). With this objective, the system operator will be

indifferent with regards to prices in the market nodes and cost functions in the field nodes.

- maximize value of flow (MVF):

$$\Pi_s^{MVF} = \max \sum_{m \in \mathcal{M}} \sum_{i \in \mathcal{I}(m)} p_{ms} \cdot \left( f_{ims} - \sum_{l \in \mathcal{L}} v_{lms} \right), \quad (5.15)$$

The strength of this formulation, MVF, compared with the MF formulation is that the ISO now routes the gas according to value. The weakness is that he has no incentive to route according to marginal cost in the fields.

If we assume that the network operator has full information regarding the cost functions of the participants, the ISO can take both value of flow and cost structure in the fields into account by maximizing social surplus.

- maximize social surplus (MSS):

$$\begin{aligned} \Pi_s^{MSS} = \max & \sum_{m \in \mathcal{M}} \sum_{i \in \mathcal{I}(m)} p_{ms} \cdot \left( f_{ims} - \sum_{l \in \mathcal{L}} v_{lms} \right) + \sum_{m \in \mathcal{M}} \sum_{l \in \mathcal{L}} P_{lm} v_{lms} \\ & - \frac{1}{2} \sum_{g \in \mathcal{G}} MC_g \cdot \left( \sum_{i \in \mathcal{O}(g)} f_{gi} \right)^2. \end{aligned} \quad (5.16)$$

$MC_g$  is the slope of the linear aggregated supply function for field  $g$ :

$$MC_g \cdot \sum_{i \in \mathcal{O}(g)} f_{gi}. \quad (5.17)$$

The supply function is found by assuming that all producers have a cost function of the form:

$$W_g = c_{lg} d_{lg}^2, \quad (5.18)$$

and that no production capacities exist. Under these assumptions, the aggregate supply function is linear.  $MC_g$  is found in the following manner:

$$MC_g = \frac{1}{\sum_{l \in \tilde{\mathcal{L}}_g} \frac{1}{2c_{lg}}}, \quad (5.19)$$

where  $\tilde{\mathcal{L}}_g$  is the set of producers  $\mathcal{L}$  and the competitive fringe in field node  $g$ . The aggregated supply function is found by horizontal summation of the individual supply functions.

Between the production facilities and the market-hubs there is a transportation network. The gas molecules are transported from nodes with high pressure to nodes with lower pressure through pipelines. The design parameters of the pipelines (length, diameter, roughness) as well as external variables (temperature) decide how much gas is transported for a given pressure difference. The relation between pressure in the nodes and flow in the pipelines are determined based on the Weymouth equation, see for instance Menon (2005). For a discussion of system effects on capacity related to pressure constraints see Midthun et al. (2006). We have chosen to linearize this expression with the formulation used in Tomasgard et al. (2007):

$$f_{ij} \leq K_{ij} \frac{RI_i}{\sqrt{RI_i^2 - RO_j^2}} r_i - K_{ij} \frac{RO_j}{\sqrt{RI_i^2 - RO_j^2}} r_j. \quad (5.20)$$

About 20 of these constraints that are approximating the Weymouth constraint are used for each pipeline in order to linearize the flow around pairs of pressure in,  $RI_i$ , and pressure out,  $RO_j$ . Here  $f_{ij}$  is the flow from node  $i$  to  $j$  and  $r_n$  is the pressure in node  $n$ .

In addition, constraints on the pressure level in each node must satisfied:

$$\underline{R}_n \leq r_{ns} \leq \bar{R}_n \quad n \in \mathcal{N}, \quad s \in \mathcal{S}, \quad (5.21)$$

where  $\underline{R}_n$  is the smallest allowed pressure in node  $n$ , and  $\bar{R}_n$  is the largest allowed pressure in node  $n$ .

In the numerical analysis, we will also look at an alternative formulation with fixed capacities. In this case the pressure constraints and the Weymouth equation are replaced with the following formulation:

$$f_{nis} \leq \bar{C}_{ni}, \quad n \in \mathcal{N}, \quad i \in \mathcal{O}(n). \quad (5.22)$$

In the following we will refer to this formulation as Independent Static Flow (ISF), while the Weymouth formulation is referred to as WF. It is non-trivial to determine appropriate values for the ISF capacities. See Midthun et al. (2006) for a discussion. In this paper we solve an optimization model (with WF formulation) where the objective is to maximize the throughput in the network. The ISF capacities are then set equal to the resulting flow pattern in this model. The WF formulation is a relaxation of this ISF formulation, but it also represents the real system more precisely as it includes the flexibility of moving bottlenecks by

adjusting pressures. The ISF formulation is more restricted but any increase in its capacities will allow a solution which is infeasible in the WF formulation.

The system operator must make sure that the mass is conserved in the network. We assume that each field is connected to a junction node, and that each market is connected to a junction node. In addition for ease of notation, we assume that no junction nodes are connected to each other. The mass balance equations are given as:

$$\sum_{j \in \mathcal{O}(g)} f_{gjs} = \sum_{m \in \mathcal{M}} \left( z_{gms} + \sum_{l \in \mathcal{L}} b_{lgm} \right), \quad g \in \mathcal{G}, \quad s \in \mathcal{S}, \quad (5.23)$$

where  $\mathcal{O}(g)$  is the set of nodes connected to a pipeline leaving from field  $g$ . In the junction nodes, the mass balance can be formulated as:

$$\sum_{g \in \mathcal{I}(j)} f_{gjs} = \sum_{m \in \mathcal{O}(j)} f_{jms}, \quad j \in \mathcal{J}, \quad s \in \mathcal{S}, \quad (5.24)$$

where  $\mathcal{I}(j)$  is the set of nodes connected to a pipeline entering node  $j$ . Finally, a constraint for the mass conservation in the market nodes must be included:

$$\sum_{n \in \mathcal{I}(m)} f_{nms} = \sum_{g \in \mathcal{G}} \left( z_{gms} + \sum_{l \in \mathcal{L}} b_{lgm} \right), \quad m \in \mathcal{M}, \quad s \in \mathcal{S}. \quad (5.25)$$

The following constraint is included in the model with maximum flow and maximum value in order to ensure that the price in the secondary market is positive:

$$p_m - c_g \cdot \left( \sum_{m' \in \mathcal{M}'} \left( z_{gm's} + \sum_{l \in \mathcal{L}} h_{lgm's} \right) \right) \geq 0, \quad g \in \mathcal{G}, \quad m \in \mathcal{M}. \quad (5.26)$$

Alternatively, we could have introduced a constraint that ensured that the ISO income was positive in total (or for all field-market combinations).

## Benchmark

In Chapter 5.5 we benchmark our solutions with an optimization model where an independent operator schedules production, routing and sale in order to maximize the social surplus of all the players in the network. The closer the equilibrium in our game gets to the benchmark solution, the better the strategy is with respect to maximizing the social surplus. The mathematical formulation of the benchmark model is given below.

$$\Pi_s^{BM} = \max \sum_{m \in \mathcal{M}} \sum_{l \in \tilde{\mathcal{L}}} (p_{ms} q_{lms} + P_{lms} v_{lms}) - \sum_{g \in \mathcal{G}} \sum_{l \in \tilde{\mathcal{L}}} \frac{1}{2} MC_{lg} d_{lgs}^2, \quad (5.27)$$

where  $MC_{lg}$  is the slope of the linear supply function of producer  $l$  in field  $g$ .

In addition, we need constraints (5.20) and (5.21) from the network operator problem presented in section 5.3. The mass balance is taken care of by:

$$\sum_{l \in \tilde{\mathcal{L}}} d_{lgs} = \sum_{j \in \mathcal{O}(g)} f_{gjs}, \quad g \in \mathcal{G}, \quad s \in \mathcal{S}, \quad (5.28)$$

$$\sum_{g \in \mathcal{G}} f_{gjs} = \sum_{m \in \mathcal{M}} f_{jms}, \quad j \in \mathcal{J}, \quad s \in \mathcal{S} \quad (5.29)$$

$$\sum_{l \in \tilde{\mathcal{L}}} (q_{lms} + v_{lms}) = \sum_{j \in \mathcal{I}(m)} f_{jms}, \quad m \in \mathcal{M}, \quad s \in \mathcal{S}. \quad (5.30)$$

## 5.4 Model properties

Our model is a General Nash Equilibrium game where the feasible regions of the players depend on the other players' decisions. Let  $X_l \in R^\alpha$  be the strategy set of player  $l$  with decision variables  $x_l = (x_{l1}, \dots, x_{l\alpha})$ . We have  $|L|$  producers and 1 ISO, constituting the set of players,  $\bar{L}$ . Define  $\beta = |L| + 1$ . The set  $X = \prod_{l \in \bar{L}} X_l$  is the full Cartesian product of the strategy sets of individual players and  $x = (x_1^T, \dots, x_\beta^T)^T$  (in the case that no common constraints existed, it would be the strategy set of the game). Also define the vector  $x_{-l}$  of all players' decisions except player  $l$ 's and correspondingly  $X_{-l} = \prod_{j \in \bar{L} | j \neq l} X_j$ .

We will define more formally the dependence between the players through the common constraints and define the point to set mapping  $K_l : X_{-l} \Rightarrow X_l$  representing player  $l$ 's feasible region, given the actions of the other players.  $K_l(x_{-l}) \subseteq X_l$ ,  $x \in X$ .

Then a generalized Nash equilibrium (GNE) is defined as a point  $x^* \in X$  that simultaneously optimizes all the players individual decision problems so that:  $x_l^* \in K_l(x_{-l}^*)$ ,  $l \in \bar{L}$  and  $\Pi_l(x^*) \geq \Pi_l(x_l, x_{-l}^*)$ ,  $x_l \in K_l(x_{-l}^*)$ ,  $l \in \bar{L}$  where  $\Pi : R^{\alpha\beta} \rightarrow R$  is the objective function of player  $l$ . That is, the Generalized Nash Equilibrium is reached when no player has incentive to change his strategy given that the other players do not change their strategy.

Pioneering results on the existence of GNE are presented in the papers of Debreu (1952) (social equilibrium) and Arrow & Debreu (1954) (abstract economy) that generalized the results of Nash (1950). Rosen (1965) is an early paper concerning not only existence but also investigating uniqueness of solutions for a



restricted class of problems. Ichiishi (1983) gave more general results concerning the existence of such GNE.

It is well known that Nash equilibria (with independent player strategy sets) can be viewed as Variational Inequalities (VI), see Lions & Stampacchia (1967) for a nice overview. An early reference formulating the generalized Nash equilibrium as a Quasi Variational Inequality (QVI) is Bensoussan (1974). See for example Ferris & Pang (1997) or Facchinei & Pang (2003) for more on the relationships between complementarity problems and Variational Inequalities. This means that in addition to existence and uniqueness proofs following the Arrow/Debreu/Rosen tradition, also the theory of VI may be used to analyze this, see Harker & Pang (1990), Harker (1991) and Pang & Fukushima (2005) for good overviews of this direction of analysis.

Following the lines of the discussion in Harker (1991), we define  $F_l(x^*) = \nabla_{x_l} \Pi_l(x_l^*, x_{-l}^*)$  and  $F(x^*) = (F_0(x^*)^T, \dots, F_{|L|}(x^*)^T)^T$ . Then the GNE may be expressed as the Quasi Variational Inequality  $QVI(F, K(x))$  :

$$F(x^*)^T(x - x^*) \geq 0, \quad x \in K(x^*), \tag{5.31}$$

where  $K(x) = \prod_{l \in L} K_l(x_{-l})$ .

It may here be noted that a standard Nash equilibrium may be expressed as a VI(F,K):

$$F(x^*)^T(x - x^*) \geq 0, \quad x \in X. \tag{5.32}$$

In our case, the  $x$  vector consist of the following variables:  $x = (b, h, d, q, f, r, z)$ . Theorem 5.2 from Chan & Pang (1982) (Theorem 2 in Harker (1991)) give conditions for existence of a solution. We use notation in accordance with what we defined above:

**Theorem 5.4.1.** *Let  $F$  and  $K$  be a point-to-point mapping and point-to-set mapping respectively from  $R^{\alpha\beta}$  into itself. Suppose that there exists a nonempty compact set  $X$  such that*

1.  $K(x) \subseteq X, \quad x \in X,$
2.  $F$  is continuous on  $X,$
3.  $K$  is a nonempty, continuous, closed and convex valued mapping on  $X.$

*Then there exists at least one solution to the  $QVI(F, K(x))$  in (5.31).*

For our problem this is satisfied by the definitions of  $F$  and  $K$ .  $F$  consists of continuous, linear expressions since our objective functions are quadratic (see Equations (5.8) and (5.14)-(5.16)). The mapping in our model is defined by Equations (5.13), (5.23) and (5.25)-(5.26). Since all these equations are linear, the conditions in Theorem 5.4.1 are satisfied. We then know that our Generalized Nash Game has at least one solution.

## Common constraints

We define common constraints as constraints where decision variables for more than one player appear. In our model, all the common constraints are continuous, linear functions (see Equations (5.33)-(5.36)) and satisfy the necessary constraint qualifications (LICQ). We can therefore apply Theorems 4-6 from Harker (1991) directly. These theorems state that if  $F$  is a continuous function in the  $VI(F, X)$  then the  $VI$  solutions are the only points in the solution set of the  $QVI(F, K(x))$  at which the optimal dual variables  $\lambda^* \in R^{p\beta}$  for the common constraints are such that  $\lambda_0^* = \lambda_j^*$ ,  $j \in \bar{L}$ . The theorems also state that any strictly interior solution (for the common constraints) of the  $QVI(F, K(x))$  is a solution to the  $VI(F, X)$  as described in (5.32). In general there will be several GNE in the game, but only the  $VI$  solutions will have a common positive value of an additional unit of a common resource (if the resource is depleted), or a zero value of a common resource for all players (if not used in full). Further, if  $F$  is strictly monotone there is a unique solution to the  $VI$  over  $X$ , Facchinei & Pang (2003), Theorem 2.3.3. This means that if an interior  $x^*$  is known, the only other GNE may be found at the boundary of the common constraints, and they will not have equal  $\lambda$ 's for the common constraints.

We have focused on the  $VI$  solution in this article. A discussion of the common constraints and the implication of requiring equal shadow prices are given in the next sections. In our model we have the following common constraints (dual variables belonging to each constraint are given to the right):

$$z_{gms} + \sum_{l \in \mathcal{L}} h_{l gms} \geq 0 \quad \tau_{gms}, \quad (5.33)$$

$$\sum_{j \in \mathcal{O}(g)} f_{gjs} = \sum_{m \in \mathcal{M}} \left( z_{gms} + \sum_{l \in \mathcal{L}} b_{l gm} \right), \quad u_{gs}, \quad (5.34)$$

$$\sum_{n \in \mathcal{I}(m)} f_{nms} = \sum_{g \in \mathcal{G}} \left( z_{gms} + \sum_{l \in \mathcal{L}} b_{l gm} \right), \quad u_{ms}, \quad (5.35)$$

$$p_m - c_g \cdot \left( \sum_{m' \in \mathcal{M}'} \left( z_{gm's} + \sum_{l \in \mathcal{L}} h_{l gm's} \right) \right) \geq 0, \quad \chi_{gms}. \quad (5.36)$$

Constraint (5.33) gives the balance between capacity sold by the system operator and capacity traded by the large producers. If this constraint is not binding, the large producers buy less capacity than the ISO sells. If the constraint is binding, the large producers are buying all capacity sold by the ISO. For the producers, the shadow price  $\tau_{gms}$  then gives the value of an additional unit of capacity bought. For the ISO, the shadow price gives the value of selling one

additional unit of capacity and thus increasing the flow in the network with one unit. Constraints (5.34) and (5.35) specify that the booked capacity in the network must be equal to the actual flow in the pipelines. Constraint (5.34) gives the balance for each field node, and constraint (5.35) gives the balance for each market node. For the producers, the shadow price  $u_{gs}$  gives the value of booking one additional unit of capacity out of field  $g$  in the primary market. For the ISO, the shadow price gives the value of increasing the difference between the flow out of field  $g$  and the capacity sold,  $z_{gms}$ . Since the flow variable is part of the objective function for the ISO, the shadow price gives the value for the ISO of increasing the flow out of the field. The same argument is valid for the shadow price  $u_{ms}$ . Constraint (5.36) ensures that the price in the secondary market is positive. The price depends on the volumes sold by the ISO and the large producers. For both the producers and the ISO, the shadow price  $\chi_{gms}$  gives the value of selling one additional unit of transportation capacity.

For the MVF and MSS formulation, we advocate that the VI solution to the GNE game is the important one. In this case the ISO will have made routing decisions which make sure that all players' marginal value of an additional transportation unit is equal. In the system we have described, the tariff is fixed and may not be changed in order to give specific incentives to the players. Hence it is clear that the ISO has a lot of influence through the routing decisions, and such a fair routing policy is preferable. For the MF formulation however, the VI solution depends on the conversion of 1  $Sm^3$  to NOK, since we relate objective functions that are not commensurable with respect to the units. Since the marginal values are given in different units, it may not make sense to require equality in the equilibrium solution. The equilibrium solution will change if we change the currency (from NOK to for instance Dollars or Euros).

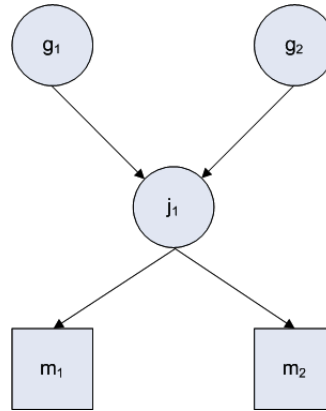
We have not been able to prove that the  $F$  function is strictly monotone, and the equilibriums we present in the numerical examples may therefore not be unique.

## 5.5 Numerical examples

We consider the network illustrated in Figure 5.4. There are two large producers, each present in both  $g_1$  and  $g_2$ . In addition, there is a competitive fringe in  $g_1$  and  $g_2$ .

In the following sections, we use our model to analyze several cases. We start with a deterministic setting in which we look at the different ISO objective function alternatives and the difference between the WF formulation and the ISF formulation. We then introduce stochasticity to our model to see how it influences the efficiency in the network.

Our model is designed for a situation where both a primary market and a



**Figure 5.4:** The network used in the numerical examples.

secondary market is used to allocate capacity in the network. The ISO influences the efficiency of the network through routing decisions and capacity distribution in the secondary market, while the large producers influence the efficiency by booking in the primary market and trading in the secondary market. In the North-Sea today, the booking in the primary market is limited by predefined booking limits and in case of overbooking a capacity allocation key is used to distribute the scarce capacity. In our model we resemble this capacity allocation key by requiring equal marginal value for all players in our common constraints. Because of this allocation rule, we can use unlimited booking rights in the primary market. In reality, the total booking rights in the North-Sea is twice the real capacity.

In each case we solve the stochastic MPC by formulating the equilibrium conditions for the problem. The equilibrium conditions consist of the aggregated KKT-conditions for all players (see Appendix 5.A). In order to find an equilibrium, we enter the KKT-conditions to the complementarity problem solver PATH (Dirkse & Ferris 1995). As we discussed in Section 5.4, we focus on the VI solution to the problem. All prices and costs are given in  $\frac{1}{100}$ NOK. Since we have inelastic demand functions in the market nodes, the social surplus will be identical with the producer surplus in our network (which is an interesting setting from a Norwegian perspective).

Node/pipeline	$\overline{R}$	$\underline{R}$	$K_{ij}$	$\overline{C}_{ij}$
$g_1$	180	170		
$g_2$	185	170		
$j_1$	170	130		
$m_1$	130	115		
$m_2$	130	100		
$g_1-j_1$			0.5	38.39
$g_2-j_1$			0.6	52.71
$j_1-m_1$			0.4	46.11
$j_1-m_2$			0.35	44.99

**Table 5.1:** The design parameters for the network

### Case 1: The different ISO objective function alternatives (WF formulation)

We start by illustrating the difference in the objective function alternatives we have presented for the ISO. The parameters in the cost functions for the large producers (see Equation (5.18)) are given as  $c_{lg}$ :  $c_{11} = \frac{5}{2}$ ,  $c_{12} = 6$ ,  $c_{21} = 3$ ,  $c_{22} = 5$ , and for the competitive fringe in field  $g$  (see Equation (5.3)):  $c_1 = 10$ ,  $c_2 = 12$ . The network parameters are given in Table 5.1. The prices in the two markets are given as:  $p_{m_1} = 130$  and  $p_{m_2} = 160$ . The tariff in the primary market is 10 for each field market combination.

When we solve the benchmark model (see Section 5.3), we get a total surplus for all the players of 7220.43. This corresponds to the maximal achievable surplus in the network. The results from the optimization with the three different objective functions for the ISO is given in Table 5.2.

As we can see from the results, the model version where the ISO maximizes social surplus (MSS) gives the highest total surplus in the network. The total surplus is only 0.8% lower than the benchmark solution. The total social surplus obtained in the MVF and MF models are, respectively, 9.41% and 1.59% smaller than the benchmark solution. We also see that the value of flow is largest in the MVF formulation, while the social surplus has decreased. The reason for the decrease in social surplus is that the production costs have increased more than the income from the spot market. The reason is that the VI solution requires equal marginal values for all players in the common constraints. Since the ISO only considers the income from the flow in the network (and not the production costs), the ISO has a large marginal value of flow and therefore forces inefficient production decisions from the producers.

The equilibrium for the MF model is, as discussed in Section 5.4, difficult to

	Max social surplus (MSS)	Max value (MVF)	Max flow (MF)
Competitive fringe $g_1$ ( <i>NOK</i> )	258.49	194.79	222.22
Competitive fringe $g_2$ ( <i>NOK</i> )	704.17	704.17	704.17
Producer 1 ( <i>NOK</i> )	3085.89	2595.33	3129.77
Producer 2 ( <i>NOK</i> )	2435.35	2282.92	2410.73
ISO profit ( <i>NOK</i> )	678.15	763.51	638.5
Social surplus ( <i>NOK</i> )	7162.05	6540.72	7105.39
Flow ( $Sm^3$ )	80.32	88.85	76.35
Value of flow ( <i>NOK</i> )	11668.39	12870.88	11207.20

**Table 5.2:** Results from the different ISO objective functions. WF formulation.

interpret since the units are different in the objective functions for the ISO and the large producers. If we change the currency (corresponds to changing the weighting of the flow for the ISO), the equilibrium also changes. By using a currency of  $\frac{1}{100}$  *NOK* we put the emphasis on the large producers, and since the social surplus corresponds to producer surplus in our models, we get a solution close to the benchmark. In Table 5.3 we see the results from changing the currency from  $\frac{1}{100}$  *NOK* to *EUR* (this is done by changing the weighting of the flow for the ISO, so the units are comparable with the results in Table 5.2). While the flow in the MF formulation was the lowest among the three alternatives in Table 5.2, it has increased to the maximum possible flow in the network in Table 5.3.

In the MSS and the MVF formulation, the change of currency will not affect the solutions, and in the remaining examples we will therefore focus on the MSS and the MVF formulations.

## Case 2: ISF versus WF formulation

In this example we look at the difference between using the WF formulation and the ISF formulation (see Section 5.3 for a discussion of how the ISF capacities are determined). We use the same parameters as in the previous example (Section 5.5). Every flow pattern obtained with the ISF formulation is feasible within the WF formulation. In the ISF formulation the capacity in the network is therefore more restricted than in the WF formulation (the reason for including the ISF formulation is that it is a common approach for economic analysis in gas networks).

The results from this optimization is shown in Table 5.4. We see the same pattern in these results as we saw for the WF formulation: the MSS formulation

	Max flow (MF)
Competitive fringe $g_1$ (NOK)	174.18
Competitive fringe $g_2$ (NOK)	704.17
Producer 1 (NOK)	2328.40
Producer 2 (NOK)	2097.78
ISO profit (NOK)	785.86
Social surplus (NOK)	6090.39
Flow ( $Sm^3$ )	91.09
Value of flow (NOK)	13191.20

**Table 5.3:** Results from the MF formulation with a larger weight on the ISO objective function.

gives the highest social surplus in the network. Compared with the WF formulation, the total surplus is reduced with 2.58% for the MSS formulation and 6.85% for the MVF formulation.

The importance of using the WF formulation depends on the network structure, the uncertainty in prices and the volume uncertainty in the TOP-contracts. Large fluctuations (as is common in natural gas prices) give more value to flexibility and therefore the WF formulation will improve the efficiency in the network. The correlation between prices is also important. High correlation may result in less difference between the ISF and the WF formulation (since the flexibility in the network is less important in this case).

	Max social surplus	Max value
Competitive fringe $g_1$ (NOK)	174.42	174.42
Competitive fringe $g_2$ (NOK)	707.18	707.18
Producer 1 (NOK)	2599.82	2329.55
Producer 2 (NOK)	2904.06	2098.80
ISO profit (NOK)	591.71	782.96
Social surplus (NOK)	6977.19	6092.91
Flow ( $Sm^3$ )	71.97	91.10
Value of flow (NOK)	10705.93	13192.28

**Table 5.4:** Results from the different ISO objective functions. ISF formulation.

Node/pipeline	$\bar{R}$	$\underline{R}$	$K_{ij}$
$g_1$	190	170	
$g_2$	185	170	
$j_1$	170	130	
$m_1$	130	100	
$m_2$	130	90	
$g_1-j_1$			0.5
$g_2-j_1$			0.6
$j_1-m_1$			0.4
$j_1-m_2$			0.35

**Table 5.5:** The design parameters for the network

### Case 3: The effect of stochasticity

In this example we look at the effect of stochasticity in our model. We use the network parameters in Table 5.5, and the following cost parameters for the large producers  $c_{lg}$ :  $c_{11} = 3$ ,  $c_{12} = 4$ ,  $c_{21} = 4$ ,  $c_{22} = \frac{7}{2}$ , and for the competitive fringe in field  $g$ :  $c_1 = 9$ ,  $c_2 = 9$ . The tariffs in the primary market are put at 10 for all field-market combinations.

The effects of stochasticity are largest when the price is volatile, and the correlation between the market prices is low, or negative. If volatility is low, or correlation is very high, the optimal booking in the first stage varies less between the scenarios. When the optimal booking in the first stage is similar in all scenarios, the effect of stochasticity is reduced.

We have chosen to use negative correlation and uniformly distributed prices between 75 and 225. Table 5.6 shows the results from the optimization. The benchmark solution in this case is 9008.59. We see that the total expected social surplus in the network has been reduced with 3.68% and 5.92% for the MSS and MV formulation, respectively, compared to the benchmark solution. The reason for these results is the capacity allocation we have chosen (focus on the VI solution), and the fact that all booked capacity must be used. In a stochastic setting, the capacity allocation in the primary market is done such that the marginal unit goes to the player that has the largest expected marginal value. When prices are very volatile, this means that the large producers in some scenarios have more capacity than they ideally would have wanted to have.

We have also looked at the wait-and-see solution (Madansky 1960) and expected result of using the expected value solution (Birge & Loveaux 1997). In the wait-and-see solution (WSS), the 15 scenarios are solved independently and we then find the expected value over the 15 scenarios. That is, we assume that



	Booking limit = $+\infty$		Wait-and-see solution	
	Max social surplus	Max value	Max social surplus	Max value
Competitive fringe $g_1$	441.91	420.63	453.98	581.19
Competitive fringe $g_2$	621.50	637.82	726.52	786.71
Producer 1 ( <i>NOK</i> )	3180.73	3275.30	3666.62	3462.53
Producer 2 ( <i>NOK</i> )	2927.52	2985.92	3303.10	3124.28
ISO profit ( <i>NOK</i> )	1505.52	1155.55	758.84	765.28
Social surplus ( <i>NOK</i> )	8677.18	8475.30	8909.06	8719.99
Flow ( $Sm^3$ )	94.43	99.84	84.93	96.89
Value of flow ( <i>NOK</i> )	14522.37	15040.02	13660.29	14830.25

**Table 5.6:** Results from the model with stochasticity. Columns 2-3 shows the result with unlimited booking for each producer, and each field-market combination, and columns 4-5 shows the wait-and-see solution with unlimited booking.

the large producers somehow get perfect information of the future before they make their decisions in the first stage. The difference between the WSS solution and the solution from the stochastic model is the expected value of perfect information (EVPI). EVPI tells us how much each player would have been willing to pay for knowing the outcome in the second stage. The results from this test (columns 4-5 in Table 5.6) shows that the total surplus in the network has increased drastically in the WSS solution. The total expected social surplus is now only 1.1% lower than the benchmark solution for the MSS formulation, and 3.2% for the MVF formulation.

In order to find the the expected result of using the expected value solution (EEV), we first solve a deterministic problem where the stochastic variables are represented with their expected values (EVP). We then use the booking decisions from the EVP in the stochastic problem. The results from the EEV formulation is shown in Table 5.7. For the MSS formulation, we see that the stochastic solution is 1.77% higher than the EEV solution. The differences are small for the MVF formulation.

## The situation without a primary market

We have also tested the model without a primary market (booking limits equal to zero), and found that the pricing mechanism in the secondary market was inefficient in this case. Since the price of capacity is based only on one producer's marginal cost (the competitive fringe), we found equilibria with a large distance

	Max social surplus	Max value
Competitive fringe $g_1$ (NOK)	420.73	420.63
Competitive fringe $g_2$ (NOK)	613.84	696.77
Producer 1 (NOK)	3262.36	3216.85
Producer 2 (NOK)	2994.11	2892.63
ISO profit (NOK)	1235.14	1236.56
Social surplus (NOK)	8526.18	8463.44
Flow ( $Sm^3$ )	95.84	99.84
Value of flow (NOK)	14587.55	15040.02

**Table 5.7:** Results from the EEV formulation.

to the benchmark solution. For each of the large producers, a decision to increase production will lead to an increase in production cost in addition to an increase in price of transportation capacity (when  $h_{lqms}$  is increased, the price of capacity increase). It may therefore be beneficial for the large producer to decrease the production even if the marginal production cost is lower than the marginal revenue.

In order to represent a situation without a primary market, a different market clearing mechanism in the secondary market is needed. As illustrated in the numerical examples in this section, the market clearing mechanism we have chosen works well in the presence of a primary market. The design and tests of new clearing mechanisms is an interesting topic for future research.

## 5.6 Conclusions

We have presented a stochastic MCP model based on Generalized Nash Equilibrium for analyzing a capacity distribution system with two stages: a primary market where only privileged players can participate and an open secondary market. This system is based on the existing capacity distribution system in the North-Sea. We have compared the results from our model with a benchmark model where a central planner with full information maximizes social surplus in the network. We have shown that there exists at least one equilibrium solution (the VI solution) to our models.

We found that the MSS formulation for the ISO lead to a higher total social surplus in the network than the alternatives. In the deterministic setting we found a difference of 0.8% between the benchmark solution and the MSS solution. The formulation requires that the system operator has full information regarding the

cost structure of the producers in the fields.

An alternative that we have considered in this paper is to maximize value of flow to the market nodes. In this case we only need to assume that the ISO knows the market prices of natural gas. In the deterministic case, the distance to the benchmark solution was 9.41% for the MVF formulation. The social surplus for the MVF formulation was 8.6% lower than the social surplus in the MSS formulation for the deterministic case, and 2.3% lower in the stochastic case. The results from the WF formulation were highly dependent on the chosen weighting in the objective functions.

Secondly, we found that stochasticity is important for our results. The booking rights lead to suboptimal solutions in some of the scenarios when prices are uncertain. The WSS solution indicated a high value of perfect information (social surplus increased with 2.67% for the MSS formulation). The EEV solution illustrated that there was a value of solving the stochastic problem (social surplus increased with 1.77% for the MSS formulation).

Finally we found that modelling the pressure constraints in the network is important. In this article we have set the fixed capacities such that the total throughput of the system is maximized. We still found that the flexibility in the WF formulation was valuable. In our example, we found that the WF formulation gave an increase of 2.65 % for the MSS formulation.

Given that the value of the flow in the pipelines in the North-Sea in 2006 was approximately 130 billion NOK, the relatively low percentage differences we have shown in this paper still amounts to a substantial amount of money.

Possible future extensions of the model are other market clearing mechanisms in the secondary market, inclusion of elastic demand functions in the spot markets for natural gas, the possibility for the large producers to hold back capacity in the secondary market and strategic behavior in the primary market.

## Appendix

### 5.A The equilibrium conditions

In this section we give the equilibrium conditions for our model. Shadow prices for constraints are introduced directly in the Lagrangian function. The matching of shadow prices with constraints can also be seen from the KKT-conditions. We distinguish two types of shadow prices: those that are unrestricted in sign (URS) and those that are restricted in sign. For the shadow prices that are restricted in sign, we use the following notation for the complementarity condition with the belonging constraint:  $G(x) - a \leq 0 \perp \varpi \geq 0$ . The complementarity condition states that either  $G(x) - a$  or  $\varpi$  must be equal to zero.

#### The large producers

The KKT-conditions for producer  $l$  is found through the Lagrangian function:

$$\begin{aligned}
 L_l = & - \sum_{g \in \mathcal{G}} \sum_{m \in \mathcal{M}} T_{gm} b_{lgm} + \gamma_{lgm} (B_{lgm} - b_{lgm}) \\
 & + \sum_{s \in \mathcal{S}} \phi_s \left[ \sum_{m \in \mathcal{M}} (p_{ms} q_{lms} + P_{lm} v_{lms}) \right] \\
 & + \sum_{s \in \mathcal{S}} \phi_s \left[ \sum_{g \in \mathcal{G}} \sum_{m \in \mathcal{M}} h_{lgms} \left( p_{ms} - c_g \left( \sum_{m' \in \mathcal{M}} \left( z_{gm's} + \sum_{l' \in \mathcal{L}} h_{l'gm's} \right) \right) \right) \right] \\
 & - \sum_{s \in \mathcal{S}} \phi_s \left[ \sum_{g \in \mathcal{G}} C_{lg} (d_{lgs}) \right] \\
 & + \sum_{s \in \mathcal{S}} \phi_s \left[ \mu_{1gs} \left( \sum_{m \in \mathcal{M}} (b_{lgm} - h_{lgms}) - d_{lgs} \right) \right] \\
 & + \sum_{s \in \mathcal{S}} \phi_s \left[ \mu_{2lms} \left( \sum_{g \in \mathcal{G}} (b_{lgm} - h_{lgms}) - q_{lms} - v_{lms} \right) \right] \\
 & + \sum_{s \in \mathcal{S}} \phi_s [\alpha_{lgms} (b_{lgm} - h_{lgms})] \\
 & + \sum_{s \in \mathcal{S}} \phi_s \left[ \tau_{gms} \left( z_{gms} + \sum_{l \in \mathcal{L}} h_{lgms} \right) \right] \\
 & + \sum_{s \in \mathcal{S}} \phi_s \left[ u_{gs} \left( \sum_{m \in \mathcal{M}} \left( \sum_{l \in \mathcal{L}} b_{lgm} + z_{gms} \right) - \sum_{j \in \mathcal{O}(g)} f_{gjs} \right) \right] \\
 & + \sum_{s \in \mathcal{S}} \phi_s \left[ u_{ms} \left( \sum_{g \in \mathcal{G}} \left( \sum_{l \in \mathcal{L}} b_{lgm} + z_{gms} \right) - \sum_{j \in \mathcal{I}(m)} f_{jms} \right) \right] \\
 & + \sum_{s \in \mathcal{S}} \phi_s \left[ \chi_{gms} \left( p_m - c_g \left( \sum_{m' \in \mathcal{M}} \left( z_{gm's} + \sum_{l \in \mathcal{L}} h_{l'gm's} \right) \right) \right) \right].
 \end{aligned}$$

Finding the derivative of the Lagrangian function with respect to the decision variables we get the KKT-conditions for optimality:

$$\begin{aligned} \frac{\partial L_l}{\partial b_{lgm}} &= -T_{gm} - \gamma_{lgm} \\ &+ \sum_{s \in \mathcal{S}} \phi_s (\mu_{1lgs} + \mu_{2lms} + \alpha_{l gms} + u_{gs} + u_{ms}) \leq 0 \quad \perp \quad b_{lgm} \geq 0, \end{aligned} \quad (5.37)$$

$$\frac{\partial L_l}{\partial \gamma_{lgm}} = B_{lgm} - b_{lgm} \geq 0 \quad \perp \quad \gamma_{lgm} \geq 0, \quad (5.38)$$

$$\frac{\partial L_l}{\partial q_{lms}} = p_{ms} - \mu_{2lms} \leq 0 \quad \perp \quad q_{lms} \geq 0, \quad (5.39)$$

$$\frac{\partial L_l}{\partial d_{lgs}} = -\frac{\partial C_{lg}}{\partial d_{lgs}} - \mu_{1lgs} \leq 0 \quad \perp \quad d_{lgs} \geq 0, \quad (5.40)$$

$$\begin{aligned} \frac{\partial L_l}{\partial h_{l gms}} &= p_{ms} - c_g \sum_{m' \in \mathcal{M}} z_{gm's} - c_g \sum_{l' \in \mathcal{L}} \sum_{m' \in \mathcal{M}} h_{l' gm's} - c_g \sum_{m' \in \mathcal{M}} h_{l gm's} \\ &- c_g \sum_{m' \in \mathcal{M}'} \chi_{gm's} - \mu_{1lgs} - \mu_{2lms} - \alpha_{l gms} + \tau_{gms} = 0, \quad h_{l gms} \text{ URS}, \end{aligned} \quad (5.41)$$

$$\frac{\partial L_l}{\partial \mu_{1lgs}} = \sum_{m \in \mathcal{M}} (b_{lgm} - h_{l gms}) - d_{lgs} = 0, \quad \mu_{1lgs} \text{ URS}, \quad (5.42)$$

$$\frac{\partial L_l}{\partial \mu_{2lms}} = \sum_{g \in \mathcal{G}} (b_{lgm} - h_{l gms}) - q_{lms} - v_{lms} = 0, \quad \mu_{2lms} \text{ URS}, \quad (5.43)$$

$$\frac{\partial L_l}{\partial \alpha_{l gms}} = b_{lgm} - h_{l gms} \geq 0, \quad \perp \quad \alpha_{l gms} \geq 0, \quad (5.44)$$

$$\frac{\partial L_l}{\partial \tau_{gms}} = z_{gms} + \sum_{l \in \mathcal{L}} h_{l gms} \geq 0, \quad \perp \quad \tau_{gms} \geq 0, \quad (5.45)$$

$$\frac{\partial L}{\partial u_{gs}} = \sum_{m \in \mathcal{M}} \left( \sum_{l \in \mathcal{L}} b_{lgm} + z_{gms} \right) - \sum_{j \in \mathcal{O}(g)} f_{gjs} = 0, \quad u_{gs} \text{ URS}, \quad (5.46)$$

$$\frac{\partial L}{\partial u_{ms}} = \sum_{g \in \mathcal{G}} \left( \sum_{l \in \mathcal{L}} b_{lgm} + z_{gms} \right) - \sum_{j \in \mathcal{I}(m)} f_{jms} = 0, \quad u_{ms} \text{ URS}, \quad (5.47)$$

$$\frac{\partial L}{\partial \chi_{gms}} = p_m - c_g \left( \sum_{m' \in \mathcal{M}} \left( z_{gm's} + \sum_{l \in \mathcal{L}} h_{l gm's} \right) \right) \geq 0, \quad \perp \quad \chi_{gms} \geq 0. \quad (5.48)$$

## The network operator

For the network operator, we present the KKT-conditions for the three different objective function alternatives. First the maximize flow objective.

**Maximize flow** The Lagrangian function for the system operator can be formulated as <sup>1</sup>:

$$\begin{aligned}
 L_s = & \sum_{s \in \mathcal{S}} \phi_s \left[ \sum_{m \in \mathcal{M}} \sum_{i \in \mathcal{I}(m)} f_{ims} + \eta_{nils} (K_{nil}^1 r_{ns} - K_{nil}^2 r_{is} - f_{nis}) \right] \\
 & + \sum_{s \in \mathcal{S}} \phi_s \left[ u_{gs} \left( \sum_{m \in \mathcal{M}} \left( \sum_{l \in \mathcal{L}} b_{lgm} + z_{gms} \right) - \sum_{j \in \mathcal{O}(g)} f_{gjs} \right) \right] \\
 & + \sum_{s \in \mathcal{S}} \phi_s \left[ \chi_{gms} \left( p_m - c_g \left( \sum_{m' \in \mathcal{M}} \left( z_{gm's} + \sum_{l \in \mathcal{L}} h_{lgm's} \right) \right) \right) \right] \\
 & + \sum_{s \in \mathcal{S}} \phi_s \left[ u_{js} \left( \sum_{m \in \mathcal{O}(j)} f_{jms} - \sum_{g \in \mathcal{I}(j)} f_{gjs} \right) \right] \\
 & + \sum_{s \in \mathcal{S}} \phi_s \left[ u_{ms} \left( \sum_{g \in \mathcal{G}} \left( \sum_{l \in \mathcal{L}} b_{lgm} + z_{gms} \right) - \sum_{j \in \mathcal{I}(m)} f_{jms} \right) \right] \\
 & + \sum_{s \in \mathcal{S}} \phi_s \left[ \omega_{1ns} (\bar{R}_n - r_{ns}) + \omega_{2ns} (r_{ns} - \underline{R}_n) \right] \\
 & + \sum_{s \in \mathcal{S}} \phi_s \left[ \tau_{gms} \left( z_{gms} + \sum_{l \in \mathcal{L}} h_{lgms} \right) \right].
 \end{aligned}$$

**KKT-conditions** The KKT-conditions:

<sup>1</sup>We have simplified the Weymouth equation such that  $K_{nil}^1$  and  $K_{nil}^2$  represents the constants in the expression

$$\frac{\partial L}{\partial f_{gjs}} = -\eta_{gjs} - u_{gs} - u_{js} \leq 0 \perp f_{gjs} \geq 0, \quad (5.49)$$

$$\frac{\partial L}{\partial f_{jms}} = 1 - \eta_{jms} + u_{js} - u_{ms} \leq 0 \perp f_{jms} \geq 0, \quad (5.50)$$

$$\frac{\partial L}{\partial z_{gms}} = -c_g \sum_{m' \in \mathcal{M}'} \chi_{gm's} + u_{gs} + u_{ms} + \tau_{gms} \leq 0 \perp z_{gms} \geq 0, \quad (5.51)$$

$$\frac{\partial L}{\partial r_{gs}} = \sum_{j \in \mathcal{O}(g)} \left( \sum_{l \in \mathcal{L}} \eta_{gjl} r_{gs} K_{gjl}^1 \right) - \omega_{1gs} + \omega_{2gs} \leq 0 \perp r_{gs} \geq 0, \quad (5.52)$$

$$\frac{\partial L}{\partial r_{ms}} = \sum_{j \in \mathcal{I}(m)} \left( - \sum_{l \in \mathcal{L}} \eta_{jml} r_{ms} K_{jml}^2 \right) - \omega_{1ms} + \omega_{2ms} \leq 0 \perp r_{ms} \geq 0, \quad (5.53)$$

$$\begin{aligned} \frac{\partial L}{\partial r_{js}} &= \sum_{g \in \mathcal{I}(j)} \left( - \sum_{l \in \mathcal{L}} \eta_{gjl} r_{js} K_{gjl}^1 \right) \\ &+ \sum_{m \in \mathcal{O}(j)} \left( \sum_{l \in \mathcal{L}} \eta_{jml} r_{js} K_{jml}^2 \right) - \omega_{1js} + \omega_{2js} \leq 0 \perp r_{js} \geq 0, \end{aligned} \quad (5.54)$$

$$\frac{\partial L}{\partial u_{gs}} = \sum_{m \in \mathcal{M}} \left( \sum_{l \in \mathcal{L}} b_{lgm} + z_{gms} \right) - \sum_{j \in \mathcal{O}(g)} f_{gjs} = 0, \quad u_{gs} \text{ URS}, \quad (5.55)$$

$$\frac{\partial L}{\partial u_{js}} = \sum_{m \in \mathcal{O}(j)} f_{jms} - \sum_{g \in \mathcal{I}(j)} f_{gjs} = 0, \quad u_{js} \text{ URS}, \quad (5.56)$$

$$\frac{\partial L}{\partial u_{ms}} = \sum_{g \in \mathcal{G}} \left( \sum_{l \in \mathcal{L}} b_{lgm} + z_{gms} \right) - \sum_{j \in \mathcal{I}(m)} f_{jms} = 0, \quad u_{ms} \text{ URS}, \quad (5.57)$$

$$\frac{\partial L}{\partial \chi_{gms}} = p_m - c_g \left( \sum_{m' \in \mathcal{M}} \left( z_{gm's} + \sum_{l \in \mathcal{L}} h_{lgm's} \right) \right) \geq 0, \perp \chi_{gms} \geq 0 \quad (5.58)$$

$$\frac{\partial L}{\partial \omega_{1ns}} = \bar{R}_n - r_{ns} \geq 0 \perp \omega_{1ns} \geq 0, \quad (5.59)$$

$$\frac{\partial L}{\partial \omega_{2ns}} = r_{ns} - \underline{R}_n \geq 0 \perp \omega_{2ns} \geq 0, \quad (5.60)$$

$$\frac{\partial L}{\partial \eta_{nis}} = K_{ni} \sqrt{r_{ns}^2 - r_{is}^2} - f_{nis} \geq 0 \quad \eta_{nis} \geq 0, \quad (5.61)$$

$$\frac{\partial L}{\partial \tau_{gms}} = z_{gms} + \sum_{l \in \mathcal{L}} h_{l gms} \geq 0, \perp \tau_{gms} \geq 0. \quad (5.62)$$



**Maximize value** The Lagrangian function for the system operator can be formulated as:

$$\begin{aligned}
 L = & \sum_{s \in \mathcal{S}} \phi_s \left[ \sum_{m \in \mathcal{M}} \sum_{i \in \mathcal{I}(m)} p_{ms} \left( f_{ims} - \sum_{l \in \mathcal{L}} v_{lms} \right) + \eta_{nils} (K_{nil}^1 r_{ns} - K_{nil}^2 r_{is} - f_{nis}) \right] \\
 & + \sum_{s \in \mathcal{S}} \phi_s \left[ u_{gs} \left( \sum_{m \in \mathcal{M}} \left( \sum_{l \in \mathcal{L}} b_{lgm} + z_{gms} \right) - \sum_{j \in \mathcal{O}(g)} f_{gjs} \right) \right] \\
 & + \sum_{s \in \mathcal{S}} \phi_s \left[ \chi_{gms} \left( p_m - c_g \left( \sum_{m' \in \mathcal{M}} \left( z_{gm's} + \sum_{l \in \mathcal{L}} h_{lgm's} \right) \right) \right) \right] \\
 & + \sum_{s \in \mathcal{S}} \phi_s \left[ u_{js} \left( \sum_{m \in \mathcal{O}(j)} f_{jms} - \sum_{g \in \mathcal{I}(j)} f_{gjs} \right) \right] \\
 & + \sum_{s \in \mathcal{S}} \phi_s \left[ u_{ms} \left( \sum_{g \in \mathcal{G}} \left( \sum_{l \in \mathcal{L}} b_{lgm} + z_{gms} \right) - \sum_{j \in \mathcal{I}(m)} f_{jms} \right) \right] \\
 & + \sum_{s \in \mathcal{S}} \phi_s [\omega_{1ns} (\bar{R}_n - r_{ns}) + \omega_{2ns} (r_{ns} - \underline{R}_n)] \\
 & + \sum_{s \in \mathcal{S}} \phi_s \left[ \tau_{gms} \left( z_{gms} + \sum_{l \in \mathcal{L}} h_{lgms} \right) \right].
 \end{aligned}$$

**KKT-conditions** The KKT-conditions:

$$\frac{\partial L}{\partial f_{gjs}} = -\eta_{gjs} - u_{gs} - u_{js} \leq 0 \perp f_{gjs} \geq 0, \quad (5.63)$$

$$\frac{\partial L}{\partial f_{jms}} = p_{ms} - \eta_{jms} + u_{js} - u_{ms} \leq 0 \perp f_{jms} \geq 0, \quad (5.64)$$

$$\frac{\partial L}{\partial z_{gms}} = -c_g \sum_{m' \in \mathcal{M}'} \chi_{gms} + u_{gs} + u_{ms} + \tau_{gms} \leq 0 \perp z_{gms} \geq 0, \quad (5.65)$$

$$\frac{\partial L}{\partial r_{gs}} = \sum_{j \in \mathcal{O}(g)} \left( \sum_{l \in \mathcal{L}} \eta_{gjl} r_{gs} K_{gjl}^1 \right) - \omega_{1gs} + \omega_{2gs} \leq 0 \perp r_{gs} \geq 0, \quad (5.66)$$

$$\frac{\partial L}{\partial r_{ms}} = \sum_{j \in \mathcal{I}(m)} \left( - \sum_{l \in \mathcal{L}} \eta_{jml} r_{ms} K_{jml}^2 \right) - \omega_{1ms} + \omega_{2ms} \leq 0 \perp r_{ms} \geq 0, \quad (5.67)$$

$$\begin{aligned} \frac{\partial L}{\partial r_{js}} &= \sum_{g \in \mathcal{I}(j)} \left( - \sum_{l \in \mathcal{L}} \eta_{gjl} r_{js} K_{gjl}^1 \right) \\ &+ \sum_{m \in \mathcal{O}(j)} \left( \sum_{l \in \mathcal{L}} \eta_{jml} r_{js} K_{jml}^2 \right) - \omega_{1js} + \omega_{2js} \leq 0, \perp r_{js} \geq 0, \end{aligned} \quad (5.68)$$

$$\frac{\partial L}{\partial u_{gs}} = \sum_{m \in \mathcal{M}} \left( \sum_{l \in \mathcal{L}} b_{lgm} + z_{gms} \right) - \sum_{j \in \mathcal{O}(g)} f_{gjs} = 0 \quad u_{gs} \text{ URS}, \quad (5.69)$$

$$\frac{\partial L}{\partial u_{js}} = \sum_{m \in \mathcal{O}(j)} f_{jms} - \sum_{g \in \mathcal{I}(j)} f_{gjs} = 0, \quad u_{js} \text{ URS}, \quad (5.70)$$

$$\frac{\partial L}{\partial u_{ms}} = \sum_{g \in \mathcal{G}} \left( \sum_{l \in \mathcal{L}} b_{lgm} + z_{gms} \right) - \sum_{j \in \mathcal{I}(m)} f_{jms} = 0 \quad u_{ms} \text{ URS}, \quad (5.71)$$

$$\frac{\partial L}{\partial \chi_{gms}} = p_m - c_g \left( \sum_{m' \in \mathcal{M}'} \left( z_{gm's} + \sum_{l \in \mathcal{L}} h_{lgm's} \right) \right) \geq 0, \perp \chi_{gms} \geq 0 \quad (5.72)$$

$$\frac{\partial L}{\partial \omega_{1ns}} = \bar{R}_n - r_{ns} \geq 0 \perp \omega_{1ns} \geq 0, \quad (5.73)$$

$$\frac{\partial L}{\partial \omega_{2ns}} = r_{ns} - \underline{R}_n \geq 0 \perp \omega_{2ns} \geq 0, \quad (5.74)$$

$$\frac{\partial L}{\partial \eta_{nis}} = K_{ni} \sqrt{r_{ns}^2 - r_{is}^2} - f_{nis} \geq 0 \quad \eta_{nis} \geq 0, \quad (5.75)$$

$$\frac{\partial L}{\partial \tau_{gms}} = z_{gms} + \sum_{l \in \mathcal{L}} h_{lgm} \geq 0, \perp \tau_{gms} \geq 0. \quad (5.76)$$

**Maximize social surplus** The Lagrangian function for the system operator can be formulated as:

$$\begin{aligned}
 L = & \sum_{s \in \mathcal{S}} \phi_s \left[ \sum_{m \in \mathcal{M}} \sum_{i \in \mathcal{I}(m)} p_{ms} \left( f_{ims} - \sum_{l \in \mathcal{L}} v_{lms} \right) + \sum_{m \in \mathcal{M}} \sum_{l \in \mathcal{L}} P_{lm} v_{lms} \right] \\
 & - \sum_{s \in \mathcal{S}} \phi_s \left[ \sum_{g \in \mathcal{G}} \frac{1}{2} MC_g \left( \sum_{j \in \mathcal{O}(g)} f_{gjs} \right)^2 \right] \\
 & + \sum_{s \in \mathcal{S}} \phi_s [\eta_{nils} (K_{nil}^1 r_{ns} - K_{nil}^2 r_{is} - f_{nis})] \\
 & + \sum_{s \in \mathcal{S}} \phi_s \left[ u_{gs} \left( \sum_{m \in \mathcal{M}} \left( \sum_{l \in \mathcal{L}} b_{lgm} + z_{gms} \right) - \sum_{j \in \mathcal{O}} (g) f_{gjs} \right) \right] \\
 & + \sum_{s \in \mathcal{S}} \phi_s \left[ \chi_{gms} \left( p_m - c_g \left( \sum_{m' \in \mathcal{M}} \left( z_{gm's} + \sum_{l \in \mathcal{L}} h_{lgm's} \right) \right) \right) \right] \\
 & + \sum_{s \in \mathcal{S}} \phi_s \left[ u_{js} \left( \sum_{m \in \mathcal{O}(j)} f_{jms} - \sum_{g \in \mathcal{I}(j)} f_{gjs} \right) \right] \\
 & + \sum_{s \in \mathcal{S}} \phi_s \left[ u_{ms} \left( \sum_{g \in \mathcal{G}} \left( \sum_{l \in \mathcal{L}} b_{lgm} + z_{gms} \right) - \sum_{j \in \mathcal{I}(m)} f_{jms} \right) \right] \\
 & + \sum_{s \in \mathcal{S}} \phi_s [\omega_{1ns} (\bar{R}_n - r_{ns}) + \omega_{2ns} (r_{ns} - \underline{R}_n)] \\
 & + \sum_{s \in \mathcal{S}} \phi_s \left[ \tau_{gms} \left( z_{gms} + \sum_{l \in \mathcal{L}} h_{lgms} \right) \right].
 \end{aligned}$$

$$\frac{\partial L}{\partial f_{gjs}} = -MC_g \sum_{j' \in \mathcal{O}(g)} f_{gjs} + \eta_{gjs} - u_{gs} - u_{js} \leq 0 \perp f_{gjs} \geq 0, \quad (5.77)$$

$$\frac{\partial L}{\partial f_{jms}} = p_{ms} - \eta_{jms} + u_{js} - u_{ms} + \tau_{gms} \leq 0 \perp f_{jms} \geq 0, \quad (5.78)$$

$$\frac{\partial L}{\partial z_{gms}} = -c_g \sum_{m' \in \mathcal{M}'} \chi_{gms} + u_{gs} + u_{ms} \leq 0 \perp z_{gms} \geq 0, \quad (5.79)$$

$$\frac{\partial L}{\partial r_{gs}} = \sum_{j \in \mathcal{O}(g)} \left( \sum_{l \in \mathcal{L}} \eta_{gjl} r_{gs} K_{gjl}^1 \right) - \omega_{1gs} + \omega_{2gs} \leq 0 \perp r_{gs} \geq 0, \quad (5.80)$$

$$\frac{\partial L}{\partial r_{ms}} = \sum_{j \in \mathcal{I}(m)} \left( - \sum_{l \in \mathcal{L}} \eta_{jml} r_{ms} K_{jml}^2 \right) - \omega_{1ms} + \omega_{2ms} \leq 0 \perp r_{ms} \geq 0, \quad (5.81)$$

$$\begin{aligned} \frac{\partial L}{\partial r_{js}} &= \sum_{g \in \mathcal{I}(j)} \left( - \sum_{l \in \mathcal{L}} \eta_{gjl} r_{js} K_{gjl}^1 \right) \\ &+ \sum_{m \in \mathcal{O}(j)} \left( \sum_{l \in \mathcal{L}} \eta_{jml} r_{js} K_{jml}^2 \right) - \omega_{1js} + \omega_{2js} \leq 0, \perp r_{js} \geq 0, \end{aligned} \quad (5.82)$$

$$\frac{\partial L}{\partial u_{gs}} = \sum_{m \in \mathcal{M}} \left( \sum_{l \in \mathcal{L}} b_{lgm} + z_{gms} \right) - \sum_{j \in \mathcal{O}(g)} f_{gjs} = 0 \quad u_{gs} \text{ URS}, \quad (5.83)$$

$$\frac{\partial L}{\partial u_{js}} = \sum_{m \in \mathcal{O}(j)} f_{jms} - \sum_{g \in \mathcal{I}(j)} f_{gjs} = 0, \quad u_{js} \text{ URS}, \quad (5.84)$$

$$\frac{\partial L}{\partial u_{ms}} = \sum_{g \in \mathcal{G}} \left( \sum_{l \in \mathcal{L}} b_{lgm} + z_{gms} \right) - \sum_{j \in \mathcal{I}(m)} f_{jms} = 0 \quad u_{ms} \text{ URS}, \quad (5.85)$$

$$\frac{\partial L}{\partial \chi_{gms}} = p_m - c_g \left( \sum_{m' \in \mathcal{M}'} \left( z_{gm's} + \sum_{l \in \mathcal{L}} h_{lgm's} \right) \right) \geq 0, \perp \chi_{gms} \geq 0 \quad (5.86)$$

$$\frac{\partial L}{\partial \omega_{1ns}} = \bar{R}_n - r_{ns} \geq 0 \perp \omega_{1ns} \geq 0, \quad (5.87)$$

$$\frac{\partial L}{\partial \omega_{2ns}} = r_{ns} - \underline{R}_n \geq 0 \perp \omega_{2ns} \geq 0, \quad (5.88)$$

$$\frac{\partial L}{\partial \eta_{nis}} = K_{ni} \sqrt{r_{ns}^2 - r_{is}^2} - f_{nis} \geq 0 \quad \eta_{nis} \geq 0, \quad (5.89)$$

$$\frac{\partial L_l}{\partial \tau_{gms}} = z_{gms} + \sum_{l \in \mathcal{L}} h_{lgm} \geq 0, \perp \tau_{gms} \geq 0. \quad (5.90)$$

## Bibliography

- Arrow, K. J. & Debreu, G. (1954), ‘Existence of an equilibrium for a competitive economy’, *Econometrica* **22**, 265–291.
- Austvik, O. G. (2003), *Norwegian Natural Gas. Liberalization of the European Gas Market*, Europa-programmet, Oslo, Norway.
- Bensoussan, A. (1974), ‘Points de nash dans le cas de fonctionnelles quadratiques et jeux différentiels linéaires à N personnes’, *SIAM Journal on Control and Optimization* **12**.
- Birge, J. R. & Loveaux, F. V. (1997), *Introduction to Stochastic Programming*, Springer.
- Chan, D. & Pang, J. (1982), ‘The generalized quasi-variational inequality problem’, *Mathematics of Operations Research* **7**, 211–222.
- Debreu, G. (1952), A social equilibrium existence theorem, in ‘Proceedings of the National Academy of Sciences’.
- Dirkse, S. P. & Ferris, M. C. (1995), ‘The PATH solver: A non-monotone stabilization scheme for mixed complementarity problems’, *Optimization Methods and Software* **5**, 123–156.
- European Union (1998), ‘Directive 98/30/EC of the european parliament and of the council’.
- European Union (2003), ‘Directive 2003/55/EC of the european parliament and of the council’.
- Facchinei, F. & Pang, J. (2003), *Finite-Dimensional Variational Inequalities and Complementarity Problems: Volume I*, Springer series of operations research, New York.
- Ferris, M. C. & Pang, J. S. (1997), ‘Engineering and economic applications of complementarity problems’, *SIREV* **39**, 669–713.
- Gabriel, S. A., Zhuang, J. & Kiet, S. (2005), ‘A large-scale complementarity model of the North American natural gas market’, *Energy Economics* **27**, 639–665.

- Gabriel, S., Kiet, S. & Zhuang, J. (2005), 'A mixed complementarity-based equilibrium model of natural gas markets', *Operations Research* **53**(5), 799–818.
- Harker, P. T. (1991), 'Generalized nash games and quasivariational inequalities', *European Journal of Operational Research* **54**, 81–94.
- Harker, P. T. & Pang, J. S. (1990), 'Finite-dimensional variational inequality and nonlinear complementarity problems: a survey of theory, algorithms and applications', *Mathematical Programming* **48**, 161–220.
- Hobbs, B. F. (2001), 'Linear complementarity models of nash cournot competition in bilateral and poolco power markets', *IEEE Transaction on Power Systems* **16**(2).
- Hu, X., Ralph, D., Ralph, E. K., Bardsley, P. & Ferris, M. C. (2004), Electricity generation with looped transmission networks: Bidding to an iso, Technical report, CMI EP Working Paper No. 65. Available at SSRN: <http://ssrn.com/abstract=556809>.
- Jing-Yuan, W. & Smeers, Y. (1999), 'Spatial oligopolistic electricity models with cournot generators and regulated transmission prices', *Operations Research* **47**(1), 102–112.
- Kall, P. & Wallace, S. W. (1994), *Stochastic Programming*, John Wiley & Sons, Chichester.
- Ichiishi, T. (1983), *Game Theory for Economic Analysis*, Academic Press, New York.
- Lemke, C. E. & Howson, J. T. J. (1964), 'Equilibrium points of bimatrix games', *Journal of the Society for Industrial and Applied Mathematics* **12**, 413–423.
- Lions, J. & Stampacchia, G. (1967), 'Variational inequalities', *Communications on Pure and Applied Mathematics* **20**, 493–519.
- Luo, Z.-Q., Pang, J.-S. & Ralph, D. (1996), *Mathematical programs with equilibrium constraints*, Cambridge University Press.
- Madansky, A. (1960), 'Inequalities for stochastic linear programming problems', *Management Science* **6**, 197–204.
- Menon, S. E. (2005), *Gas pipeline hydraulics*, CRC Press, Boca Raton, USA.
- Midthun, K. T., Bjørndal, M. & Tomasgard, A. (2006), Modeling optimal economic dispatch and flow externalities in natural gas networks. Working paper, NTNU, Trondheim, Norway. Submitted to international journal.

- Nash, J. (1950), Equilibrium points in n-person games, in ‘Proceedings of the national academy of sciences’.
- Pang, J. S. & Fukushima, M. (2005), ‘Quasi-variational inequalities, generalized nash equilibria, and multi-leader-follower games’, *Computational management science* **2**.
- Patriksson, M. & Wynter, L. (1999), ‘Stochastic mathematical programs with equilibrium constraints’, *Operations Research Letters* **25**, 159–167.
- Rosen, B. (1965), ‘Existence and uniqueness of equilibrium points for concave n-person games’, *Econometrica* **33**, 520–534.
- Smeers, Y. (2003*a*), ‘Market incompleteness in regional electricity transmission. Part I: The forward market’, *Networks and Spatial Economics* **3**, 151–174.
- Smeers, Y. (2003*b*), ‘Market incompleteness in regional electricity transmission. Part II: The forward and real time markets’, *Networks and Spatial Economics* **3**, 175–196.
- Tomasgard, A., Rømo, F., Fodstad, M. & Midthun, K. (2007), Optimization models for the natural gas value chain, in G. Hasle, K.-A. Lie & E. Quak, eds, ‘Geometric Modelling, Numerical Simulation, and Optimization: Applied Mathematics at SINTEF’, Springer, chapter Optimization Models for the Natural Gas Value Chain.
- Yao, J. (2006), Cournot Equilibrium in Two-Settlement Electricity Markets: Formulation and Computation, PhD thesis, University of California, Berkeley, USA.
- Yao, J., Adler, I. & Oren, S. (2006), Modeling and computing two-settlement oligopolistic equilibrium in a congested electricity network. Working paper, UCEI.
- Yao, J., Oren, S. S. & Adler, I. (2004), Computing cournot equilibria in two settlement electricity markets with transmission constraints, in ‘Proceedings of the 37th Hawaii International Conference on System Sciences’.