

Christoffer Rame Sigvathsen

Downhole errors

Master's thesis in MTPETR

Supervisor: Pål Skalle

June 2019



Christoffer Rame Sigvathsen

Downhole errors

Master's thesis in MTPETR
Supervisor: Pål Skalle
June 2019

Norwegian University of Science and Technology
Faculty of Engineering
Department of Geoscience and Petroleum

 **NTNU**
Norwegian University of
Science and Technology

Abstract

One of the most important challenges in the industry today is finding ways to reduce cost. One approach is to make the drilling process more effective by eliminating sources of non-productive time. By removing the source of an event that delayed drilling operations, not only is the associated equipment damage and cost of operations reduced, but it also removes the delay on the project. The ability to simultaneously know the position of a well and maintain directional control is fundamental in the construction of new wells. Methods on how to best achieve these two goals have changed through the years and are under further development to enhance the ability to reach hydrocarbons.

This thesis is based on the reports and Real Time Drilling data from two wells in the North Sea. The data was analysed in an effort to uncover a correlation between the events that caused Non-Productive time and the lack of directional control. Reports were analysed alongside the Real Time Drilling data to gain an understanding of the well and its events. The data required to be processed in a MATLAB script, enabling it to be read and presented. Most of the events that took place in the wells are not directly correlated with directional control. If an error occurs and it is wrongfully assumed the positioning of the well is correct, other sources of the error are more easily pointed out as the obvious culprit.

Sammendrag

En av de viktigste utfordringene i industrien i dag er å finne tiltak som kan redusere kostnad. En måte å gjøre dette på er å gjøre boreoperasjonen mer effektiv ved å fjerne kildene til nedetid. Ved å fjerne kilden til en hendelse som hindret boreoperasjonen, blir ikke bare den assosierte utstyrskostnaden og driftskostnadene redusert, men også forsinkelsen på prosjektet. Å kunne vite den nøyaktige posisjonen til en brønn mens man borer, samtidig som man opprettholder styringskontroll, er fundamentalt i konstruksjonen av nye brønner. Metoder på hvordan man oppnår disse egenskapene har forandret seg oppgjennom årene og er under stadig utvikling for å kunne nå nye hydrokarboner.

Denne tesen baserer seg på rapportene og sann-tid boredata fra to brønner i Nordsjøen. Dataen ble analysert i et forsøk på å finne en sammenheng mellom årsakene til nedetid manglende styring. Rapportene ble analysert sammen med sann-tids boredata for å oppnå en forståelse for brønnene og hendelsene i dem. Dataen måtte bli lest i et MATLAB program som gjorde for å gjøre den lesbar og presentabel. De fleste hendelsene i brønnene er ikke direkte tilknyttet styring. Hvis en feil finner sted og det blir urettmessig antatt at posisjonen til brønnen er korrekt, er det lettere å peke ut en annen kilde for feilen.

Acknowledgements

Upon the completion of this master thesis at the Norwegian University of Science and Technology there are people I would like to express my sincerest gratitude towards.

- My supervisor, Professor Pål Skalle for his unwavering patience and guidance.
- The department of geoscience and petroleum, providing me with the necessary data for completing this assignment. Especially Ann-Helen Kirknes and Lisbeth Hultmann for providing me with sound advice and encouragement.
- Anisa Noor Corina for the creation and help with the logview MATLAB program that made it possible to read and present the data.
- Friends and family for their support
- Helene Kristiansen Andersen for putting up with me

Christoffer Rame Sigvathsen

14.06.2019

Table of Contents

Abstract.....	i
Sammendrag	iii
Acknowledgements.....	v
Table of Contents.....	vii
List of Figures	ix
1 Introduction	1
2 Overview of the ontological method	3
2.1.1 Finding the causal probability.....	5
3 Methods of directional control	7
3.1 Directional control by means of collars and stabilizers	8
3.1.1 Packed hole assembly	9
3.1.2 Pendulum assembly	10
3.1.3 Fulcrum assembly	11
3.2 3D Rotary Steerable system	12
3.2.1 Push the bit.....	12
3.2.2 Point the bit.....	13
3.3 Bent assembly and down hole mud motors.....	14
4 Case Studies.....	17
4.1 Case 1 - 34/10 C-47.....	18
4.1.1 17,5” Section.....	18
4.1.2 12 ¼” section	20
4.1.3 8 ½” section	22
4.1.4 Mechanically stuck	23
4.1.5 Poor hole cleaning.....	24
4.1.6 Poor casing and cement job	25
4.1.7 Loss to formation	26
4.1.8 Failed PowerDrive	28
4.1.9 Directional control	28
4.2 Case 2 - 33/12-B-17A	31
4.2.1 8 ½” Section.....	32

4.2.2	6" Section 33/12-B-17AT1	32
4.2.3	6" Section sidetrack 33/12-B-17AT2.....	32
4.3	Main failures	33
4.3.1	Loose formation	33
4.3.2	Sidetrack	33
4.3.3	Directional Control	33
5	Discussion.....	37
5.1	Directional control.....	37
5.1.1	Case 1.....	37
5.1.2	Case 2.....	37
5.1.3	Poor hole cleaning.....	38
5.1.4	Logistics	38
5.1.5	Opportunity cost.....	39
5.1.6	Progress in drilling technology	39
5.2	Self-evaluation	40
5.2.1	Quality of data.....	40
5.2.2	Quality of model	41
5.2.3	Future improvements	41
6	Conclusion.....	43
7	References	45
8	Abbreviations	47
9	Appendix A	49
10	Appendix B	51

List of Figures

Figure 2-1; An ontology model is built as a hierarchical network. The top level consists of generic concepts, the middle level of general and specific domain concepts and the lowest level of real cases from previous drilling operations (Skalle, Aamodt et al. 2013).....	4
Figure 2-2; Four different paths leading to one failure state. Assuming each relation strength between concept were all 0.2, the uppermost Path Strength would become $0.2 * 0.2 * 0.2 = 0.008$	5
Figure 3-1; The directions the well is able steer in. The Azimuth indicates the bit in the North, South, East and West repectivly. The inclination Up and Down (Brechan, Corina et al. 2017)	8
Figure 3-2; BHA: Packed hole, Pendulum and Fulcrum Modified:(Brechan, Corina et al. 2017)	9
Figure 3-3; Typical packed hole assembly (Brechan, Corina et al. 2017).....	9
Figure 3-4 Drilling string in a straight inclined hole (Lubinski and Woods 1953) Without WOB, the assembly tends to make a vertical well. Force in bit increases the inclination.	11
Figure 3-5; Typical pendulum assembly (Brechan, Corina et al. 2017)	11
Figure 3-6; Fulcrum assembly (Brechan, Corina et al. 2017).....	12
Figure 3-7; The figure shows how the Direct and Indirect bit force Push-the-bit tools uses different types of forces to steer the bit (Brechan, Corina et al. 2017).....	13
Figure 3-8; Point the bit 3DRSS (Geopilot from HES) (Brechan, Corina et al. 2017)	14
Figure 3-9; Full view of stator housing. The arrows show the mud flow direction (Brechan, Corina et al. 2017).....	15
Figure 4-1; RTDD from the 17,5 section.....	19
Figure 4-2; RTDD from the 12,5 section.....	21
Figure 4-3; RTDD from the 8 ½” section	23
Figure 4-4; "Cuttings" found on the BHA during clean-up.....	24
Figure 4-5; An illustration showing the process of filling the annulus with cement. The heavy presence of gravel and cuttings makes it difficult for fluids to pass through the annulus.	24
Figure 4-6; The presence of particles in the annulus caused a bad cement job th.....	25
Figure 4-7; The figure illustrates how the fluids penetrates the cement through the micro annulus and enters the formation. This figure represents attempts at filling the micro annulus with cement.....	27

Figure 4-8; Formation integrity test. After the microanalyses were filled with cement, the pressure was increased in the annulus to test if the formation was strong enough to withstand the required pressure.27

Figure 4-9; The figure shows the horizontal displacement of the well. A merge of the N/S and the E/W diagram with the intent of showing the most representative direction of the well in 2D space.....29

Figure 4-10; A 3D model of the wellpath in the reservoir. The camera is angled to give a top-down view from the side of the well. Showing the angle that give the longest possible representation of the well.....30

Figure 4-11; Pathing of Well 34/10 C-4732

Figure 4-12; Time distribution during the Well 33/12-B-17 operations.....34

Figure 4-13; Figure representing the time distribution without the effects caused by weather and/or other logistical interruptions.35

Figure 9-1 Figure shows the horizontal displacement of the well in the North/South direction. In this case the well was angled south, thereby the negative numbers on the diagram.49

Figure 9-2 This diagram shows the pathing of the well in the East/West direction49

Figure 9-3 A 3D model of the wellpath in the reservoir. The camera is angled at a top-down view at the end of the well. The angle gives a less impression of the length of the well but shows more clearly how the pathing changes as it lines up in order to enter the reservoir.50

1 Introduction

This report will explore some of the errors that can occur during a drilling process. The focus will be on identifying failures where the leading cause can be traced back to issues regarding directional control.

Real time drilling data (RTDD) will be analysed where the source of the error or chain of errors have caused some amount of non-productive time (NPT). The cause of the NPT can be identified by looking into the data, identifying the errors that may have occurred and work backwards to the source of the problem. This subject must be approached in such a way because it is not always obvious, in the chain of events, what the triggering factor could have been.

The master work will therefore be two-fold; first an overview of the wells where these events took place and an analysis of the errors. In the second part an attempt will be made to trace the errors back to its source, utilizing real time drilling data. This method may help identifying the symptoms in the RTDD and may possibly help preventing these kinds of errors in future drilling operations. In the oil industry today, there is a renewed focus on time and cost efficiency, and reducing NPT is important in order to improve drilling operations. Wells are continuously getting longer and more complicated as all the “easy hydrocarbons” have been depleted. Longer wells have a smaller margin for error, since a small difference in inclination will have a larger impact on the well path corresponding with the length of the well.

The methods displayed in this thesis regarding directional control are used worldwide today. Their effectiveness is undisputed, but they also showcase the need for further development. The wells of tomorrow require new technologies, and a margin for error that is close to zero.

2 Overview of the ontological method

To prevent misunderstandings, certain concepts need to be properly defined in the context of this work.

Event

An event is when something unwanted is happening. The more severe events are called errors and failures.

Error

An event where something has not gone as planned. This does not mean that the event itself necessarily is a problem, but it is noteworthy in the context of what else is happening. The severity of an error varies. Sometimes fixing an error can be routine but usually leads to some amount of non-productive time (NPT). Steps often are required to fix or mitigate an error.

Failures

In this context of drilling operations, a failure is considered an event that leads to considerable amounts of (NPT). Steps need to be taken to fix a failure. It is more severe than an error.

Symptom

A symptom is something that indicates an error or a failure. It does not need to be a problem in itself. But when the symptom is present it increases the probability that a specific event, failure or chain of event is present.

Chain of events

A chain of events is considered one or more events that happen because of each other. As such, there is often a source that was the main cause of these events. Sometimes an error or a failure can lead to several more failures. This can make it hard to pinpoint the exact chain of events since the failures are often discovered at the same time, and it is not always clear which one happened first.

Ontology

The approach of this master thesis is based on the ontological method. A drilling ontology is built on analysis of historical data. Recognition of symptoms (process-deviations) in the drilling process is the first step. The symptoms are explained and changed to concepts (Figure 2-1). By looking at the cause-effect relationships, pathways can be made by linking the causes to failures, thereby explaining the NPT. The next step is to implement the drilling ontology in the drilling process. RTDD can be automatically evaluated and linked to the on-line detected symptoms and a diagnosis of the drilling process can be made (Skalle, Aamodt et al. 2016).

The ontological method is a hierarchical classification of relevant concepts where each concept is put into sub-classes. The method also includes a cause and effect relationship between each concept. In practice, when the method is fully implemented it can describe the probability of any event based on previous events.

The ontological method proved hard to implement in conjunction with directional control. Since directional control, or the lack of it, does not fit all the definitions set by the ontological method, a different approach to the problem was chosen. However, the ontological method's approach on how to solve a problem systematically is still in focus.

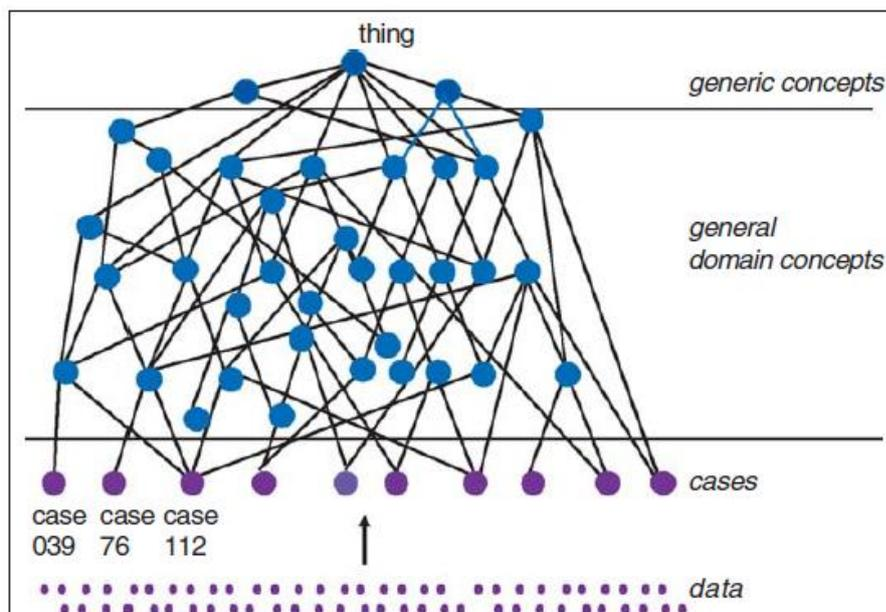

Figure 2-1; An ontology model is built as a hierarchical network. The top level consists of generic concepts, the middle level of general and specific domain concepts and the lowest level of real cases from previous drilling operations (Skalle, Aamodt et al. 2013)

2.1.1 Finding the causal probability

A chain of event is also called a path. Each concept in the path is multiplied, leading to a Path Strength. All Path Strengths are added into a Total Path Strength. Path Strength of one path is divided by the total sum is called Path Probability.

After finding all the concepts that are relevant for a specific case, they are added together multiplicatively to find each paths strength. This makes it possible to determine how likely a specific path is. Later we can calculate the probability of each path. While not all concepts were present in each case, this is only to illustrate the approach when analyzing a case with adequate data for an ontological approach.

Sometimes a path has the same origin concept, but a different set of concepts leading to the failure. This is because an error can cause or indicate several other internal concepts, failures and errors. This creates a branching path that leads to a different set of cause and effect relationship between concepts, but eventually leading to the same failure.

This only strengthens the probability of the original concept since it has the capability of setting in motion several sets of events that led to the failure.

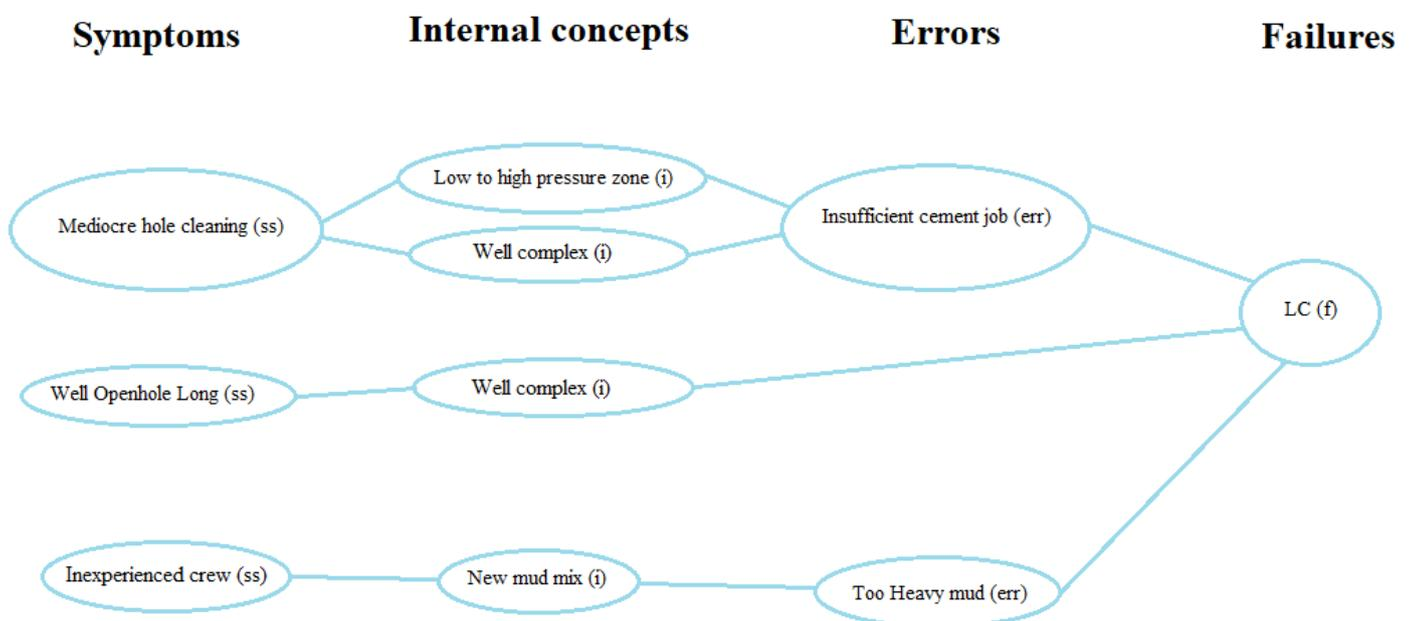

Figure 2-2; Four different paths leading to one failure state. Assuming each relation strength between concept were all 0.2, the uppermost Path Strength would become $0.2 * 0.2 * 0.2 = 0.008$

3 Methods of directional control

One of the main focuses in the master thesis is the failures that occur during drilling operations that can be caused by lacking directional control. It is therefore important to understand how directional control works, and what the limitations are. More advanced methods in directional control are being developed, but some of the wells that will be reviewed in this thesis were drilled using less modern techniques. Furthermore, these basic methods of controlling the direction of the well remain important today.

Directional control is defined as the ability to track and control the pathing of the well during the drilling process. This includes being able to steer the well's inclination as well as the azimuth (Figure 3-1). But the ability to steer the bit counts for little if the ability to know the bit's location relative to its surroundings.

There are many reasons for applying directional drilling when constructing a well. Today, vertical wells in the North Sea are only applied for exploratory wells and as the first two wellbore sections in production wells. The improved recovery and enhanced flexibility provided by highly deviated or horizontal wells are far more beneficial than the enhanced cost. Directional drilling allows many wells to be drilled from the same platform, which is especially advantageous during offshore operations. Otherwise inaccessible areas obstructed by salt domes or fault zones can be circumvented and horizontal perforations improve recovery.

Different methods of directional drilling are introduced below to give an understanding of how directional control is applied in the drilling process.

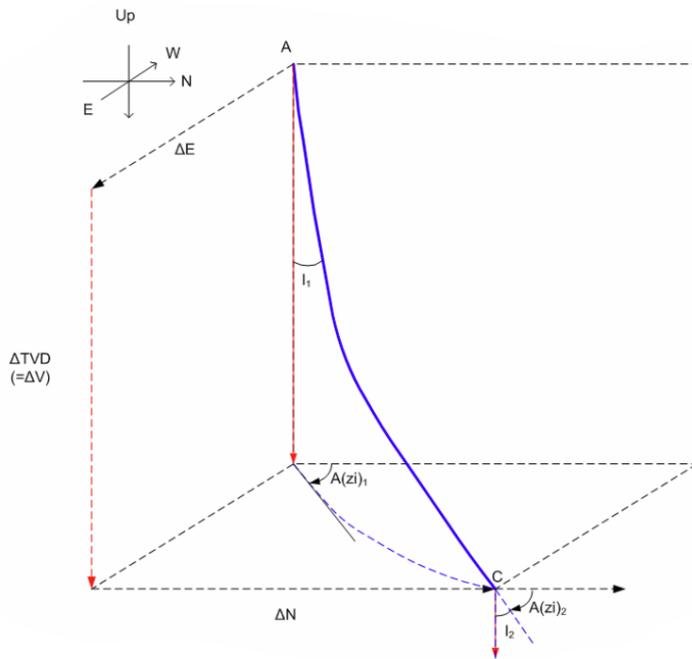

Figure 3-1; The directions the well is able steer in. The Azimuth indicates the bit in the North, South, East and West respectively. The inclination Up and Down (Brechan, Corina et al. 2017)

3.1 Directional control by means of collars and stabilizers

To explain how collars and stabilizers can contribute to directional control, this master thesis will shortly explain how a bottom hole assembly (BHA) is put together and what the purpose is.

The BHA mainly consist of the bit, drill collars, stabilizers and any other equipment that enhances the operation. Equipment like measuring tools or downhole motors. The primary function of the drill collars is to apply weight on the bit. The segments are much heavier than the ordinary drill string and are often separated by stabilizers. The collars are placed as close to the bit as possible to prevent buckling and apply as much force on the bit as possible. Stabilizers are used to center the BHA in the well and control the pathing. This is the key to directional control using collars and stabilizers; manipulating the distance, placement and weight on bit (WOB) to force the bit to drill in the desired direction.

There are three primary setups used to control the BHA, as also shown in Figure 3-2:

- Packed/hold assembly
- Pendulum/drop assembly
- Fulcrum/building assembly

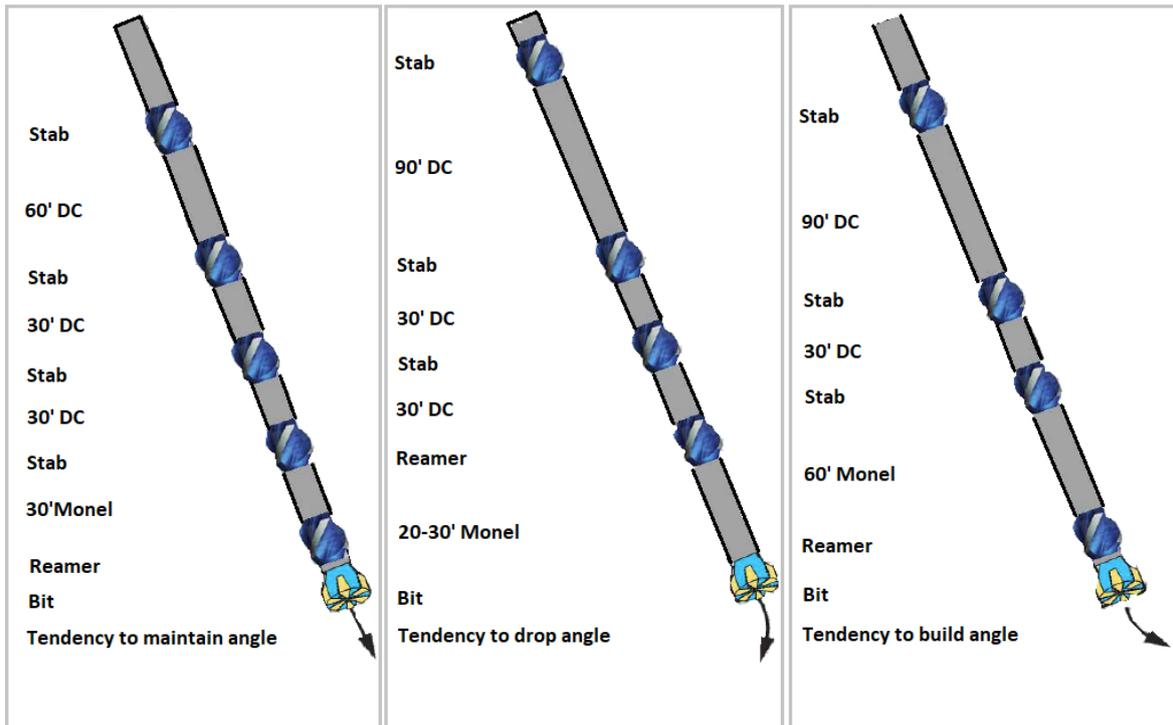

Figure 3-2; BHA: Packed hole, Pendulum and Fulcrum Modified:(Brechan, Corina et al. 2017)

3.1.1 Packed hole assembly

Packed hole assemblies are meant to maintain the angle the well is currently being drilled. It does this by having three or more stabilizers at specific points that centers the BHA and bit, as shown in Figure 3-3. This forces the bit to maintain its current direction. The BHA is stiff, especially in the front where the DC closest to the bit is short. This means they don't allow for much steering. Today this would have been unacceptable, because wells are normally drilled with very few runs. Back when using these old-school assemblies bits did not have a long life. Therefore, the BHA could be changed to effectively steer the well since the bit had to be changed anyways. The packed hole assembly was used to maintain and control the tangent section in a directional well (Brechan, Corina et al. 2017)



Figure 3-3; Typical packed hole assembly (Brechan, Corina et al. 2017)

3.1.2 Pendulum assembly

Pendulum- or drop assemblies are primarily used to drill vertical wells. However, they are sometimes used to drop well inclination (Figure 3-5). In this assembly the stabilizer closest to the bit is removed, allowing the bit to settle in the well. Imagine a drillstring in a straight inclined hole (Figure 3-4). The drill string is not in contact with the wall near the bit, but some distance away contact is made at the Point of Tangency. If not acted upon by a force, the weight of the string between the bit and the Point of Tangency will drive the bit in the direction of gravity and tend to make a vertical well.

When weight is applied (WOB) the force tends to move the well away from vertical. The sum of these forces can be adjusted in such a way as to increase or maintain the current angle.(Lubinski and Woods 1953) The side force on the bit can be estimated with equation (3-1)

$$F_s = \frac{1}{2} W_c \cdot B_f \cdot L_t \cdot \sin(inc) \quad (3-1)$$

Where, F_s is the side force on the bit, W_c is the Drill collar weight bellow the tangency point, L_t is the length of the pendulum, inc is the inclination, and B_f is the buoyancy factor. To increase the effectiveness of the pendulum/drop assembly WOB should be decreased and RPM and pump pressure increased. That way allowing the weight of the DC to drop the angle. This method is highly effected by the type of bit and the firmness of the formation (Brechan, Corina et al. 2017).

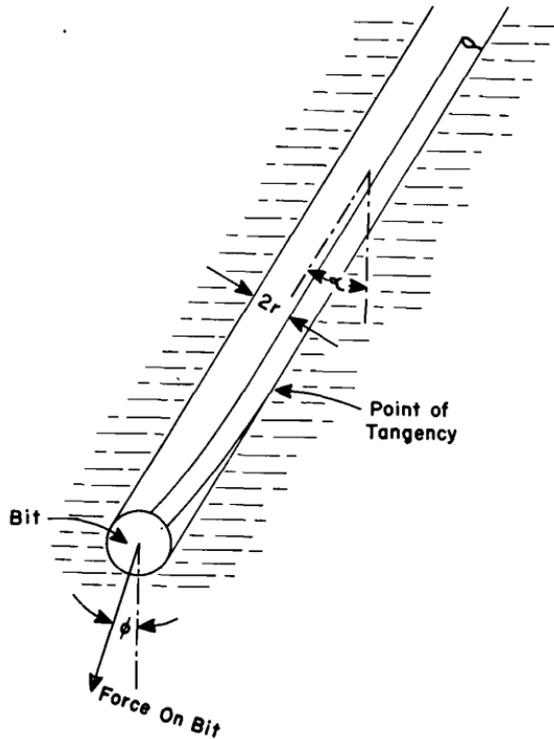

Figure 3-4 Drilling string in a straight inclined hole (Lubinski and Woods 1953) Without WOB, the assembly tends to make a vertical well. Force in bit increases the inclination.



Figure 3-5; Typical pendulum assembly (Brechan, Corina et al. 2017)

3.1.3 Fulcrum assembly

Fulcrum assembly or building assembly is designed to increase the angle of the well. It is comprised of DC's and stabilizers that are spaced further apart as seen in Figure 3-6. When applying WOB the DC section above the bit will bend and sag against the low side of the hole. This tilts the bit upwards, building the angle of well. The size of the collars, WOB and position of the stabilizers can be adjusted to change the rate of build-up (Brechan, Corina et al. 2017).

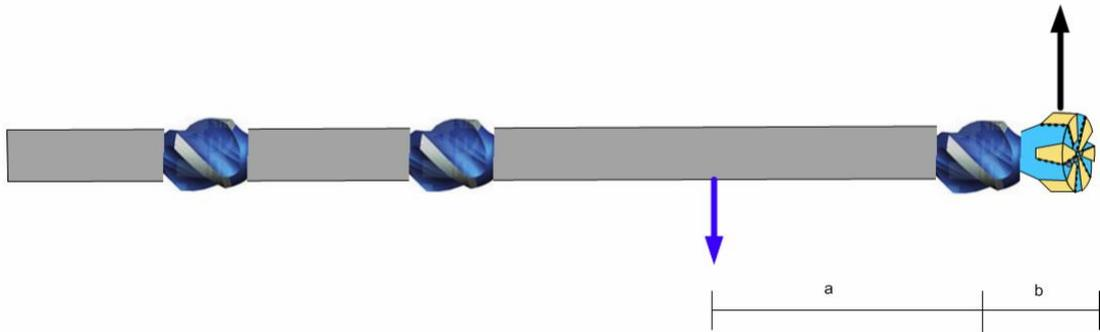

Figure 3-6; Fulcrum assembly (Brechan, Corina et al. 2017)

3.2 3D Rotary Steerable system

The 3D Rotary Steerable system (RSS) or push of assembly is the most modern system for directional control discussed in this master thesis. The RSS manipulates three points of contact between the drill string and the borehole wall to control the direction of the bit. While the RSS shares some similarities with other methods of directional control like mud motors, it is a significant improvement. The most important one is the ability to rotate the drill string while maintaining directional control. This allows for easier transportation of cuttings which helps clean the well while drilling (Brechan, Corina et al. 2017).

There are two RSS systems used maintain directional control while rotating the string: Push the bit and point the bit.

3.2.1 Push the bit

In principle the Push-the-bit system uses a tool on the BHA that pushes towards the wall of the well to steer the bit. The complexity of the tool comes from the ability to rotate the string while using non-rotary collars and the non-rotary sleeve where the tool is fitted. The sleeves are fitted with a drive which rotate in to opposite direction relative to the drill string, at almost the exact speed of the drill string. Usually three arms or plates are fitted on the sleeve that push towards the wall of the well to steer the bit in the desired direction. The sleeve itself slowly rotates as well, because having a tool that never rotates can become a source of accumulated cuttings and other unwanted effects that can inhibit the drilling process. To counteract the slow rotation of the sleeve, a few times a minute, the arms are programmed to activate when they are in the position to steer the bit in the wanted direction. This also serves

as a failsafe. On newer RSS's, should one arm fail, the remaining ones will not. This makes it so that the drilling operation can continue with two of three arms operational, saving the driller from a trip out off hole (Brechan, Corina et al. 2017).

Similarly, to a fulcrum assembly the RSS tool can be fitted to either directly push the bit in the desired direction or indirectly bend the sub to point the bit (Figure 3-7).

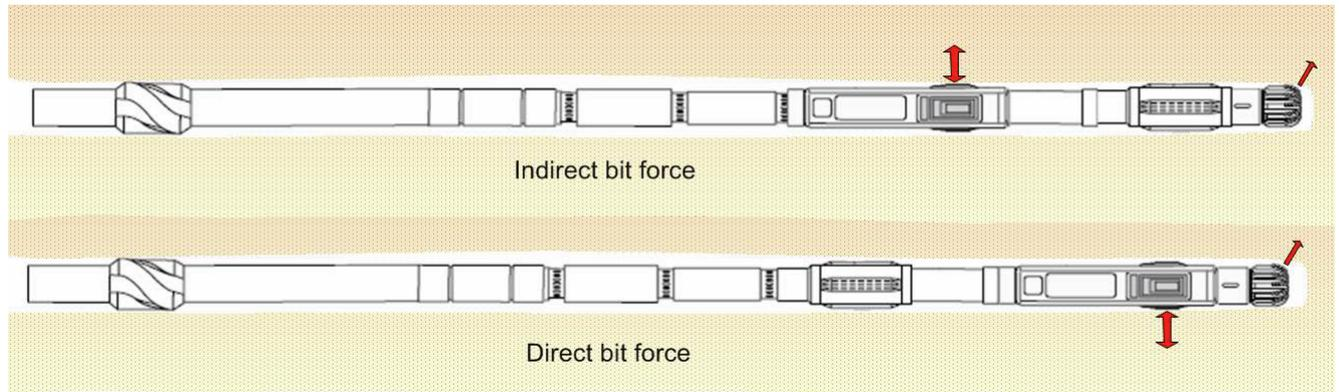

Figure 3-7; The figure shows how the Direct and Indirect bit force Push-the-bit tools uses different types of forces to steer the bit (Brechan, Corina et al. 2017)

3.2.2 Point the bit

Point the bit RSS system is similar to the Push the bit system in the way that it allows the rotation of the drill string while steering the bit. It achieves this applying a system that mounts the bit on an eccentric ring with bearing that allows the bit to be pointed at an angle (Figure 3-8). There exist two versions of this tool. The first has only one eccentric ring, and because of this it is impossible to align the bit with the rest of the tool. As such, for it to drill in a straight line the angle must continuously be adjusted. Alternatively, a system with two eccentric rings can be applied. This way the rings can counteract each other, allowing the bit to align with the rest of the tool (Brechan, Corina et al. 2017).

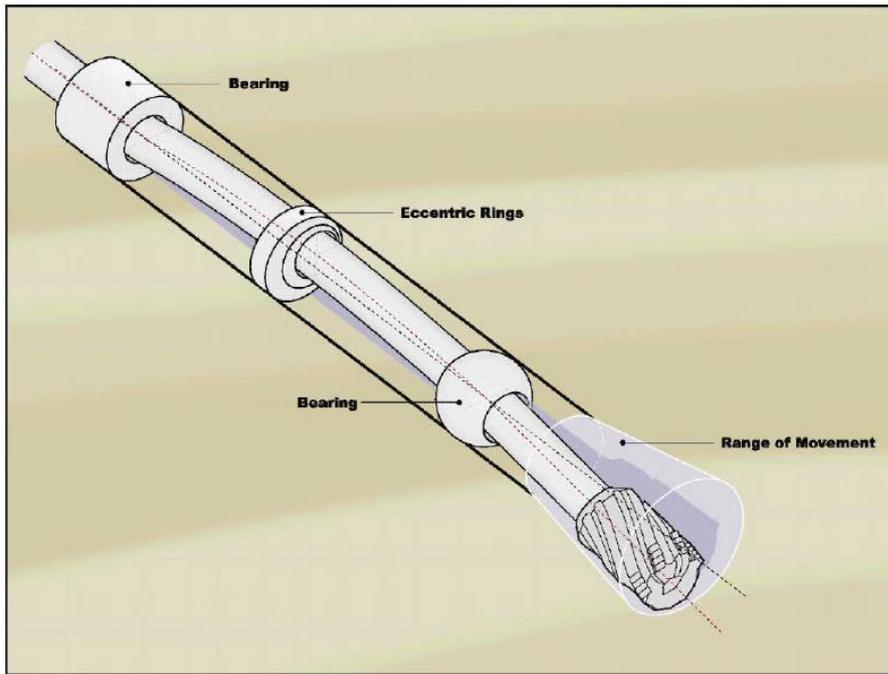

Figure 3-8; Point the bit 3DRSS (Geopilot from HES) (Brechan, Corina et al. 2017)

3.3 Bent assembly and down hole mud motors

Mud motors is one of several types of positive displacement motors that used to be a common tool to provide directional drilling in the North Sea. It's a downhole motor that is powered by the circulation of mud. This allows the bit to rotate without rotating the drillstring. A bend is then created in a universal joint, forcing the bit to drill the well in the desired direction. Without the downhole motor, the bend would simply rotate at the same rate as the bit, canceling out any attempt at directional drilling.

One of the big advantages with the downhole motors is that the bent joint can be removed, and normal directional and straight-hole drilling proceed.

Deviation control is the process of keeping the wellbore contained within some prescribed limits relative to inclination angle, horizontal excursion from the vertical, or both.

(Bourgoyne, Millheim et al. 1991) It is important to always know the position of the well, and control where the well is drilling. Should one loose one of these parameters for even a short time, the well could be irreparably damaged. The mud motor is one of the tools used to ensure proper steering.

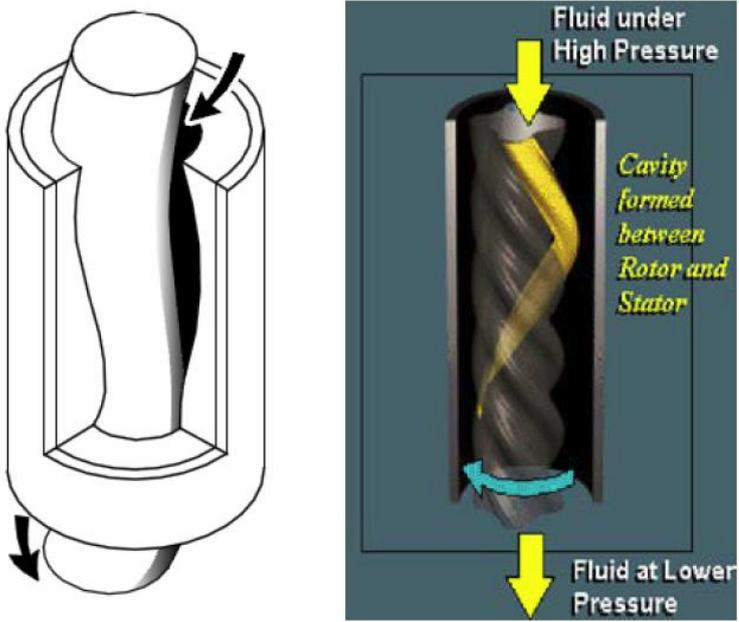

Figure 3-9; Full view of stator housing. The arrows show the mud flow direction (Brechan, Corina et al. 2017)

4 Case Studies

The focus in this master thesis will be on its case studies. Each case contains the relevant events from one well in the North Sea at the border between Norwegian and British sector. The cases did not have the same amount or quality of data and are therefore approached differently. Case 1 has the most available data and can provide the most detailed recreation of events that took place when the well was drilled. Case 2 contains less data but provides a detailed end of well report.

The cases in question are:

- Case 1 - Well 34/10 C-47
The well with the most complete data. A modern well where they experienced difficulties during the drilling process that caused considerable NPT.
- Case 2 - Well 33/12-B-17A
A modern well with some available RTDD. Was drilled out from a previous existing well in order to reach another part of the reservoir and improve the production.

To find and evaluate the wells needed for the cases studies the following systematic approach was used; starting with the acquisition of well data from various oil companies. The institute was able to provide most of the relevant data on a multitude of different wells in different oilfields. Two representative wells were then chosen that showed a noticeable degree of symptoms that were relevant to the goal of this thesis.

The end of well reports (EOWR) were used to identify the recurring symptoms and errors that caused failures leading to NPT and the ones that are relevant to the task are presented in this thesis. The errors are correlated with the real-time drilling data (RTDD) to investigate the causes for the symptoms that lead to the NPT. Finally, an assessment of the cause and effect relationship between the symptoms and the failures leading to the NPT errors are made.

4.1 Case 1 - 34/10 C-47

Well name:	34/10 C-47
Field:	Gullfaks, North Sea
Available data:	EOW and complete RTDD
Entered date:	28.11.2005
Completed date:	02.05.2006
Total depth mMD:	4399 m
Errors:	<ul style="list-style-type: none">- Human error- Poor hole cleaning- Poor cement job
Failures:	<ul style="list-style-type: none">- Mechanically stuck- Loss of circulation/loss to formation- Failed powerdrive

This case study contains the most complete historical data and is therefore the most advanced. The well in question has data available for most of the operations that took place during drilling and completion. This makes it easier to make a proper analysis of the well.

The case study will be split up into two parts:

1. A methodical run-through of the relevant events that took place in the 17,5 “section, the 12¼” section and the 8 ½” section of the well. As well as any events that took place during completion.
2. An overview of the events that took place during the drilling process and the resulting NPT it caused

4.1.1 17,5” Section

Notable events:

- 2 times Failed PowerDrive
- Mechanically stuck due to bad mud mix
- Problems regarding hole-cleaning

From the data we can see where most of the NPT occurred. The red line (Figure 2-1 Track 1) represents the depth of the bit at any given time, while the blue line represents the total depth the well has achieved. During the first run the PowerDrive, responsible for maintaining directional control, failed. Communication was later established, and it was decided to continue drilling. At point ((1) Figure 4-1 Track 1 (1)) the bit started behaving

erratically and it became stuck. It became hard to maintain the circulation of mud in the hole. It was decided to Pull out of hole (POOH) (Figure 4-1 Track 1(2)). This was more difficult than anticipated and was only possible by backreaming most of the well. A bad mud mix had caused coagulation in the well and made drilling almost impossible. They used the opportunity to repair the BHA, perform a BOP test and circulate the well clean of residue from the bad mix. Drilling operations continued, but they were soon forced to POOH again due to another failure on the PowerDrive (Figure 4-1 Track 1(3)).

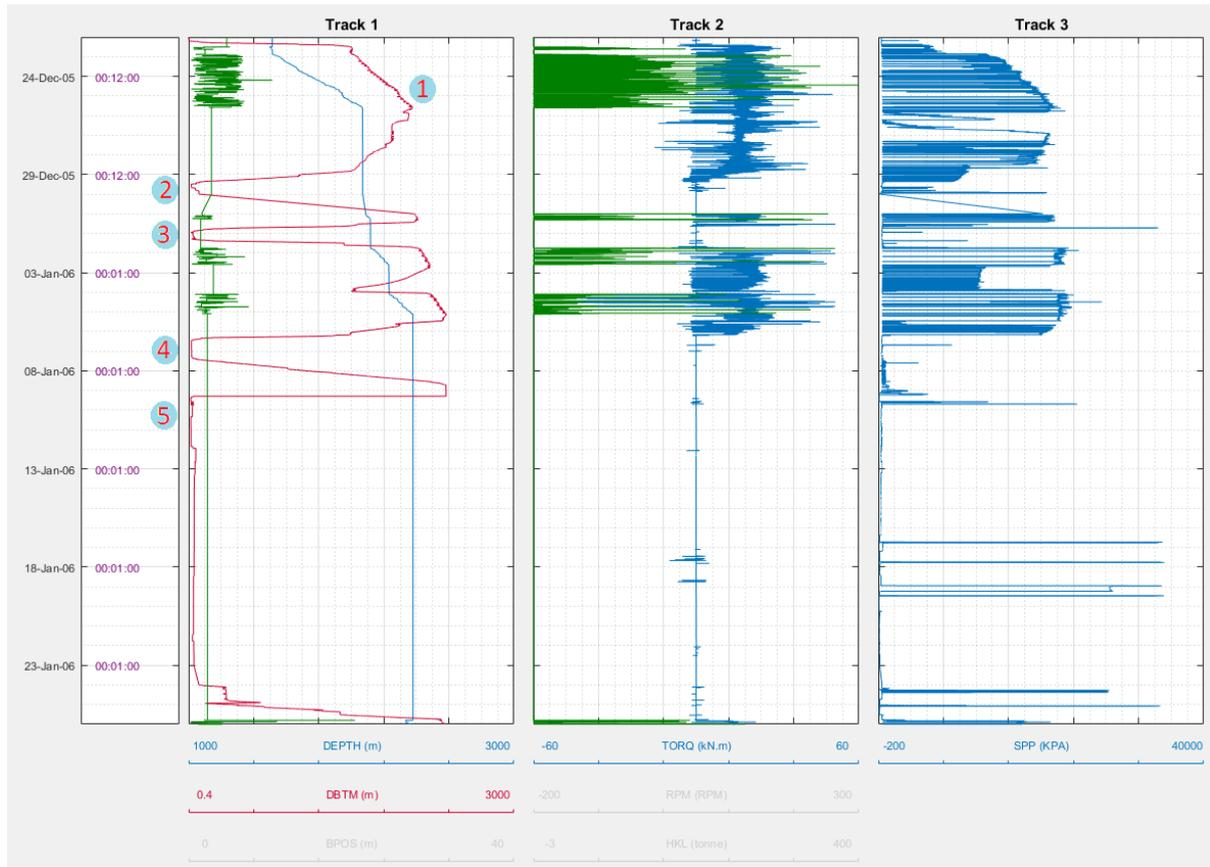

Figure 4-1; RTDD from the 17,5 section

When the 17,5” well reached target depth the string was POOH. The hole was circulated clean and casing was set and cemented. A LOT was performed to 1.50 SG (Standard Gravity), when the minimum requirement was 1.63 SG. A FIT (Formation integrity test) was also performed and leaked of a much lower pressure than expected.

A leakoff test is the process of increasing the pressure in the well to test if the casing, cement and formation is strong enough to withstand drilling until the next casing shoe. This is done until the formation fractures. A formation integrity test is similar, but is only performed until the casing, cement and formation can withstand the predetermined pressure, or until it breaks (Jr., Millheim et al. 1986).

4.1.2 12 ¼" section

Notable events:

- Waiting on weather (WOW)
- Lost circulation / Cement squeeze
- Running leak tests

Early in the 12 ¼" section the well was about to enter a high-pressure zone. In expectance to this the SPP (Surface pump pressure) was steadily increased. This caused the Effective Circulation Density (ECD) to reach a pressure above the expected high-pressure zone before it was encountered. In (Figure 4-2) the blue line in Track 3 represents the SPP. From the data we can see the jump in pressure at January the 28th (Figure 4-2 Track 3(1)).

The increased ECD caused Loss of circulation (LOS) to the formation. The pressure dropped and 10m³ mud was lost to the formation before a stable Bottom hole Pressure (BHP) was established. Two attempts at sealing the formation followed by two failed LOT's were then performed. The well was subsequently killed by displacing cement into the loss zones. The increased SPP we can observe at this time (Figure 4-2 Track 3(2)) is caused by the attempts at sealing the loss zone, performing Leak of tests (LOT's) and finally displacing the kill mud.

Because of the heavy loss zones, it was decided to implement Measure While Drilling (MWD) and use Managed Pressure drilling (MPD). To do this it was also necessary to use a Positive Displacement motor (PDM) to prevent the string from rotating while drilling the run (Figure 4-2 Track1(3)).

On February 10th they reached target depth at 2787m. After setting casing and squeezing mud several LOT's and cleanup runs was performed until they were able to continue with the 8 ½” section. We can observe in the data at (Figure 4-2 Track 1(4)) where they needed multiple runs for setting and cementing the casing and at (Figure 4-2 Track 3(5)) where the SPP increased to set the cement and squeeze the kill mud before continuing with the next section of the well.

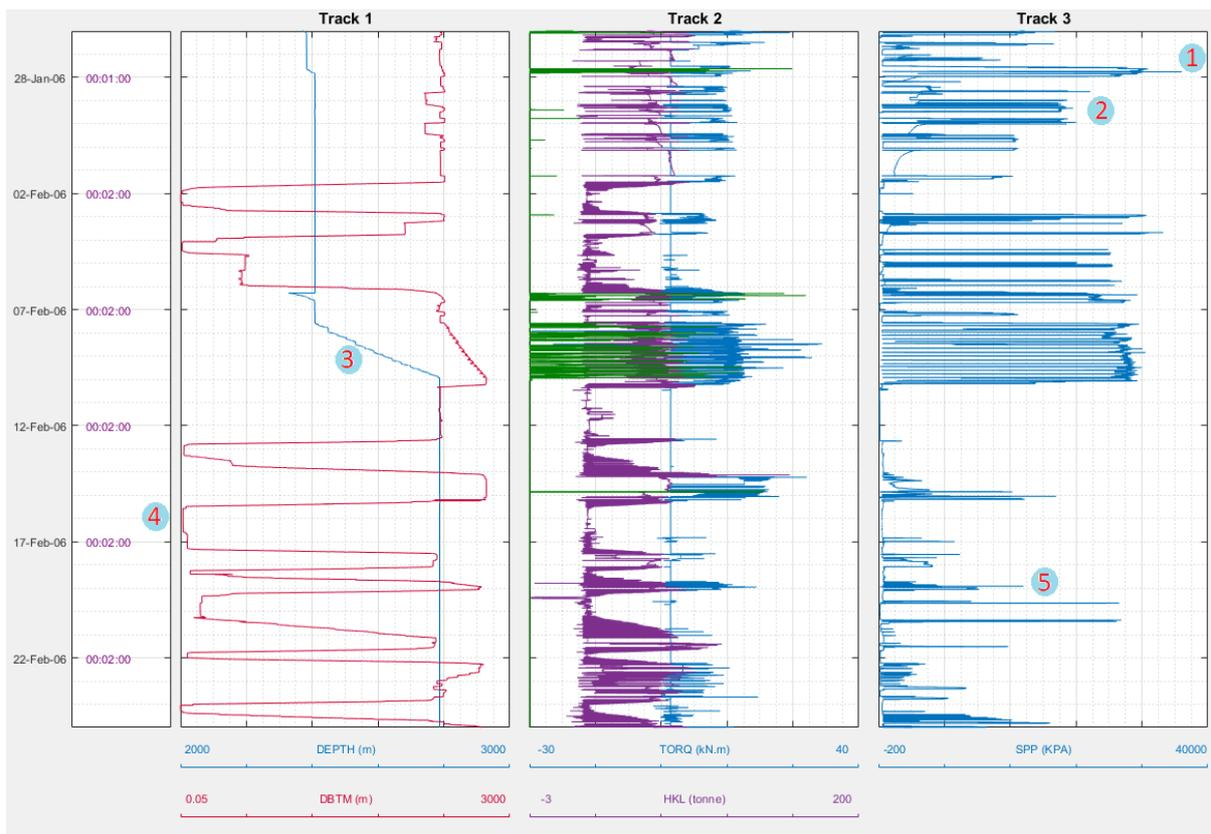

Figure 4-2; RTDD from the 12,5 section

4.1.3 8 ½” section

Notable events:

- LOS / LOT's
- Failed PowerDrive
- Bad cement job

The 8 ½” section was drilled in one run despite suffering steering problems and LC. The section was drilled almost entirely with losses between 5-6 m/h. This was within what was deemed acceptable. The SPP was adjusted according to pore pressure test so that they were able to drill with the least amount of losses possible. The driller opted for a set of drilling parameters that were proven to be effective when drilling the last run in this formation. This included a low ROP and as a result it was not possible to get sufficient dogleg. By using a combination of running sections with high WOB and reaming other sections while having low WOB, they were able to manually rectify the steering problems. From the data, where the green line represents the WOB, we can see how the WOB fluctuated during this section of the well (Figure 4-3 Track 2(1)).

At 4109mMD, only 300m for target depth, the PowerDrive failed. Drilling did continue since the pathing of the well matched that of the planed wellpath before the tool failed and it continued to drill straight. The section was therefore completed in a single run.

Upon reaching target depth and completing the 8 ½” section of the well, the setting of the 7” casing began. Problems were experienced early with establishing returns. A previously unidentified loss zone was discovered in the connection shoe to the previous 9 5/8” liner. Equipment not available on the platform needed to be ordered to seal the loss zones. Because of the sealing procedure several runs regarding cement squeezing and new LOT's had to be performed. The cleanup runs after theses operations were not enough, and complicated later operations. New obstructions in the well were created that lead to miss-runs, and new cement squeezing had to be performed.

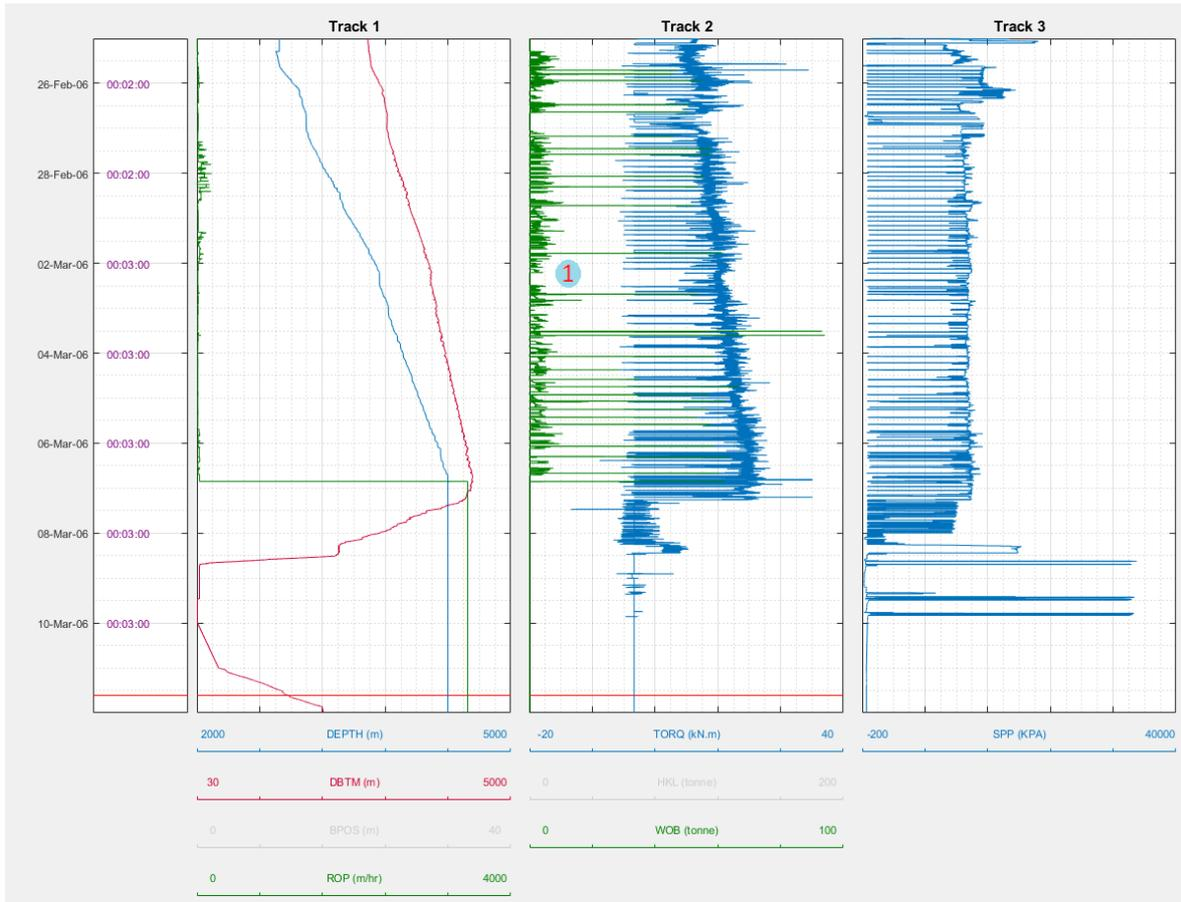

Figure 4-3; RTDD from the 8 1/2" section

4.1.4 Mechanically stuck

In the 17 1/2" section a specific mud was used to prevent bit balling. It was however not approved since it contained an oil-based polymer, and the well was only approved for water-based mud. The polymer was therefore substituted with another. This resulted in a mud mix that coagulated. Large cuttings came on the shakers, and the BHA had to be back reamed from 1814 to 135 m inside the 20" casing. The back reaming lasted 96 hours, and the BHA came out "encapsulated" in sticky cuttings. We can observe in (Figure 4-3 Track 2) that the torque required to POOH at times was equal torque that was needed during drilling. This illustrates the difficulty experienced when POOH.



Figure 4-4; "Cuttings" found on the BHA during clean-up

4.1.5 Poor hole cleaning

In the 17 ½", 12 ¼" and 8 ½" section they experienced problems squeezing the cement below the previous casing shoe. This later led to Loss of circulation. In all the sections it was concluded that the reason for the subpar cement job was improper hole cleaning. After cement squeeze in the 12 ¼" section, proper circulation of the hole was not performed. It was made clear that EOW rapport that other wells passing through the same formations also had problems regarding insufficient cleaning after a cement job. Even so the cleanup job was unsatisfactory.

Poor hole cleaning can be a cause to many follow-up problems (Figure 4-5). The buildup of particles in the annulus obstructs the entry of the casing and can obstruct the retraction of the drillstring if the buildup is too heavy.

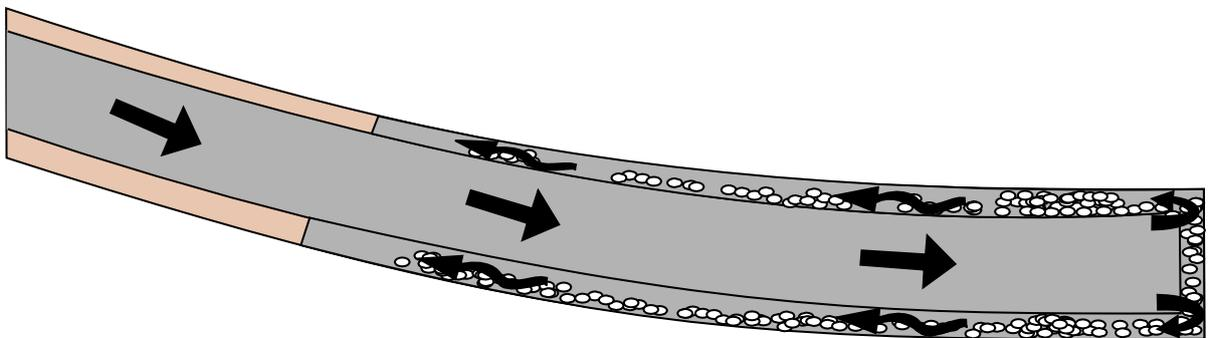

Figure 4-5; An illustration showing the process of filling the annulus with cement. The heavy presence of gravel and cuttings makes it difficult for fluids to pass through the annulus.

4.1.6 Poor casing and cement job

In the 17 ½” section a Leak of test (LOT) was performed in the casing shoe. Probably due to a poor cement job the formation integrity test (FIT) leaked off at a much lower pressure than was expected (Figure 4-5). Since the leak of pressure was so low, it was expected the pressure had leaked off into micro annulus in the cement and fractured the formation shallower than the shoe depth. It was then decided to perform a new cement squeeze to seal the micro annulus. It took two attempts before reaching sufficient pressure on the FIT.

When RIH the 9 5/8” liner into the 12 ¼” section, a miscommunication led to the mixing of a heavier mud than what was safe to proceed with. This was discovered and pumped out of hole until they regained stable returns.

After the casing was set, 20 m³ cement was pumped and displaced. A pressure test was conducted but the pressure broke at 156 bar and 5 m³ mud was lost. The packer was tried set at 40 tons, but there were no indication the packer was actually set. The pressure test of the annulus was aborted due to risk of cement out of the liner lap and into previous casing.

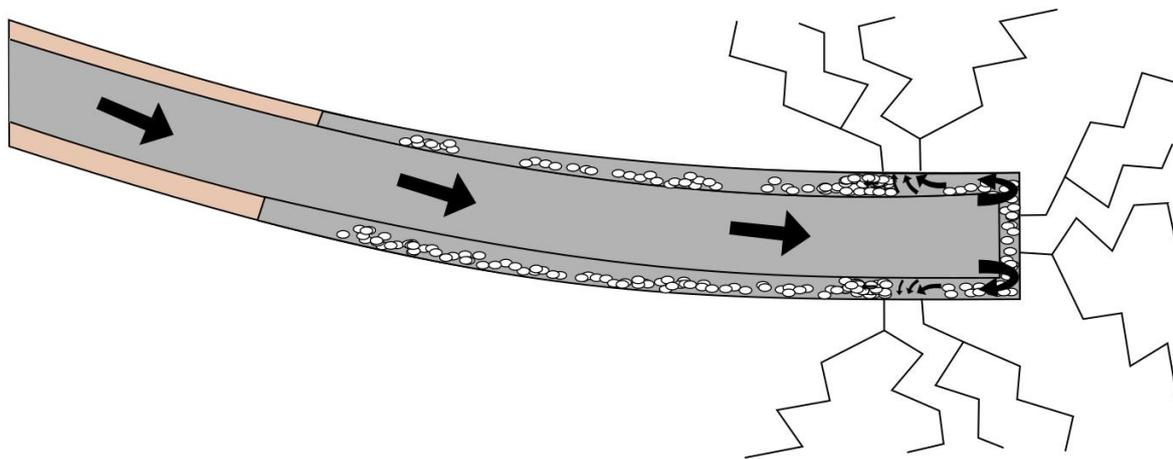

Figure 4-6; The presence of particles in the annulus caused a bad cement job th

4.1.7 Loss to formation

Loss to formation occurred in two fashions

1. Natural losses to the formation as the ECD either exceeded the fracture pressure of the formation or the interaction with unknown pockets of low-pressure areas.

The 12 ¼” section was the longest part of the well. Drilling started at 2383m, but not 50m was drilled before 10 m³ was lost to the formation. This happened because it was decided to increase the bottom hole pressure steadily to 315 bars in preparation to enter a higher-pressure zone. The formation was not able to withstand the high pressure in the well since the high-pressure zone had not yet been encountered. Losses were stabilized by reducing the circulation of mud and adjusting the mud density.

A pack pill was tried set and squeezed into the formation. A formation integrity test (FIT) was performed, but 17 m³ was again lost to the formation. Several logging runs and pack pills were run, but they were unable to seal the loss zone. More than 130 m³ mud was lost to the formation. It was then decided to kill the well by displacing 1.88 SG kill mud. A total of 23,2 m³ cement was squeezed into the formation.

After killing the well, they were able to continue drilling in MPD mode (Managed Pressure Drilling).

The 8 ½ section suffered losses at 2997-3003 mMD. It was decided to continue drilling with losses between 5-8 m³/h until completion.

2. A subpar cement job could not withstand the pressure buildup and caused fractures in the formation. This is similar to how natural losses occur with one difference; before the drilling fluids can reach the natural wall in the well, the cement needs to be bypassed. The FIT discovered an unreliable seal created by the sub-par cement job, and the presence of micro anulus in the cement. Luckily this was discovered and repaired before drilling continued.

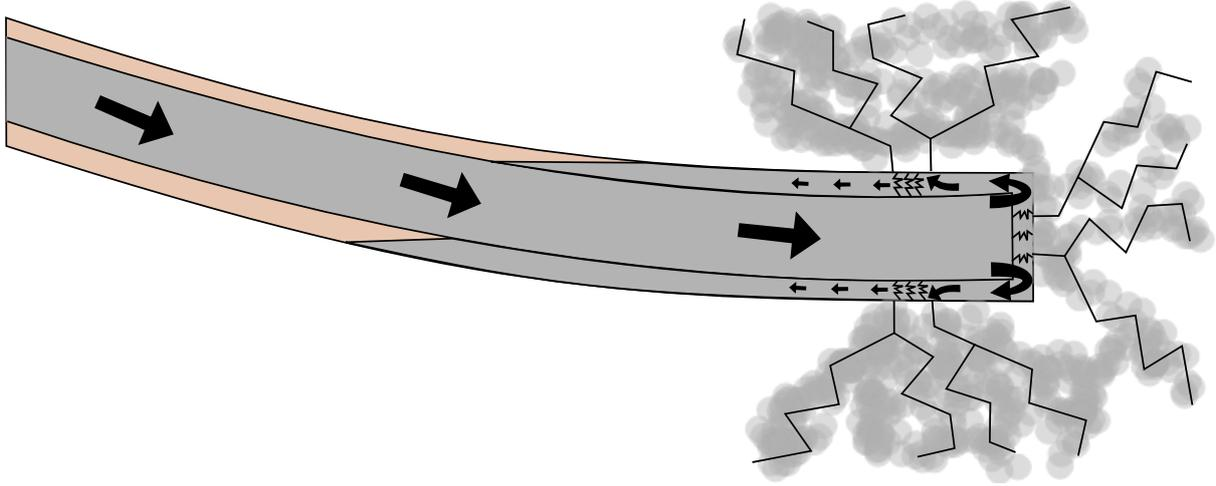

Figure 4-7; The figure illustrates how the fluids penetrates the cement through the micro annulus and enters the formation. This figure represents attempts at filling the micro annulus with cement.

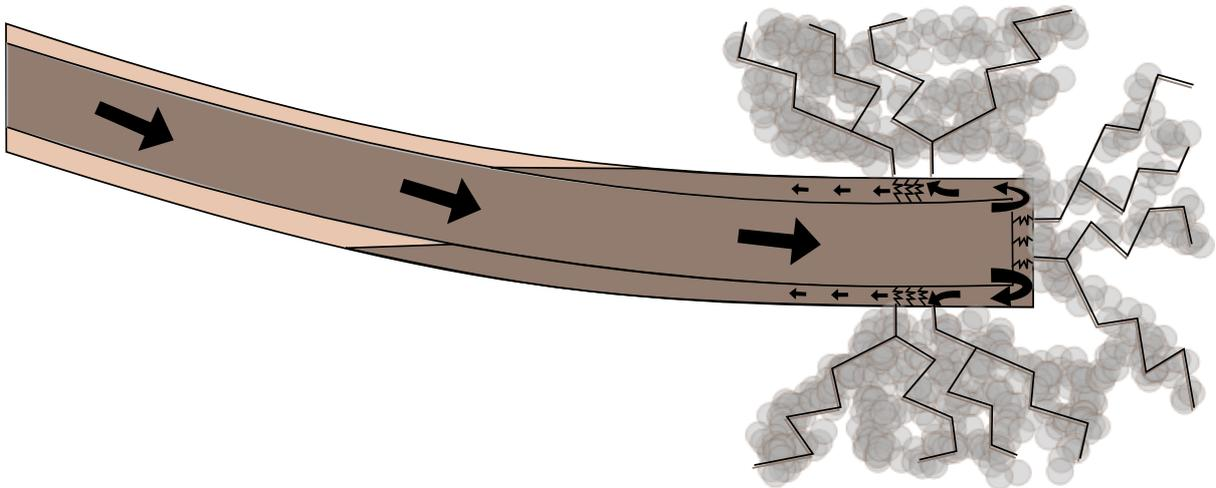

Figure 4-8; Formation integrity test. After the microanalyses were filled with cement, the pressure was increased in the annulus to test if the formation was strong enough to withstand the required pressure.

4.1.8 Failed PowerDrive

The PowerDrive failed twice in the in 17,5” section. The first time it happened drilling continued when some communication was recovered. The driller was then able to detect that the PowerDrive had directed the well in the proper direction before failing. It was the decided to keep drilling with the failed PowerDrive until the pathing of the well became unrepairable or another issue should arise. This way they used the time as effectively as possible without needing to POOH.

The second time the PowerDrive failed there was no communication between the driller and the tool. The BHA was therefore POOH. Another failure occurred on the PowerDrive in the 8 ½” only 300m from target depth. The direction of the bit as the powerdrive failed was optimal, and it was therefore decided that drilling could commence to target depth with a failed powerdrive. The operation succeeded and the well reached TD.

4.1.9 Directional control

Drawing the figure showing the pathing of the well can be challenging to accurately represent. The pathing in this case changes direction regularly in both inclination and azimuth direction. The most accurate way to present the data is a 3D illustration based on the data from the well. A simple figure in 2D space was first created based on the directional data. As seen in Appendix B the data was presented in a North/South and West/East direction in meters from the origin point of the well. The 2D representation was a combination of these two directions and the vertical depth of the well (Figure 4-9). Additional figures showing the displacement of the well can be seen in Appendix A.

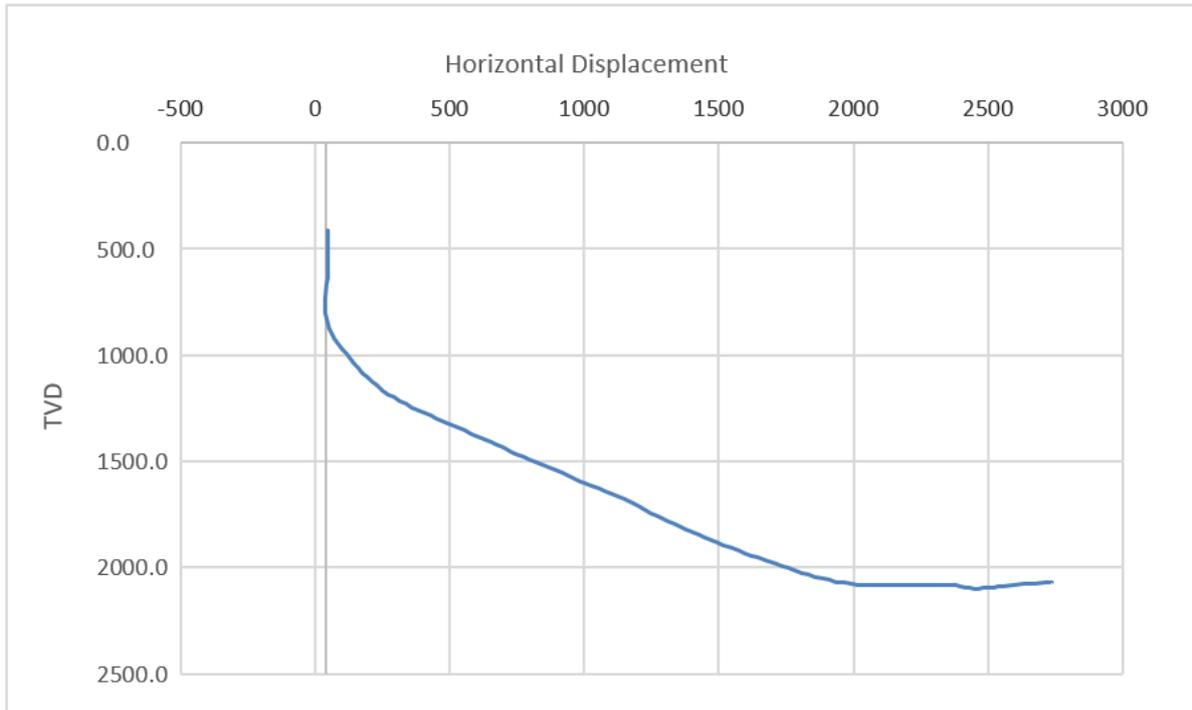

Figure 4-9; The figure shows the horizontal displacement of the well. A merge of the N/S and the E/W diagram with the intent of showing the most representative direction of the well in 2D space.

A 3D model is more representative of the pathing of the well. By using a script and importing the data onto MATLAB a rendition of the wellpath in 3D space was created (Figure 4-10). Because of the complexity of showing 3D figures on paper, the 2D renditions can help understand the pathing of the well. Another angle of the 3D wellpath is shown in

Appendix A.

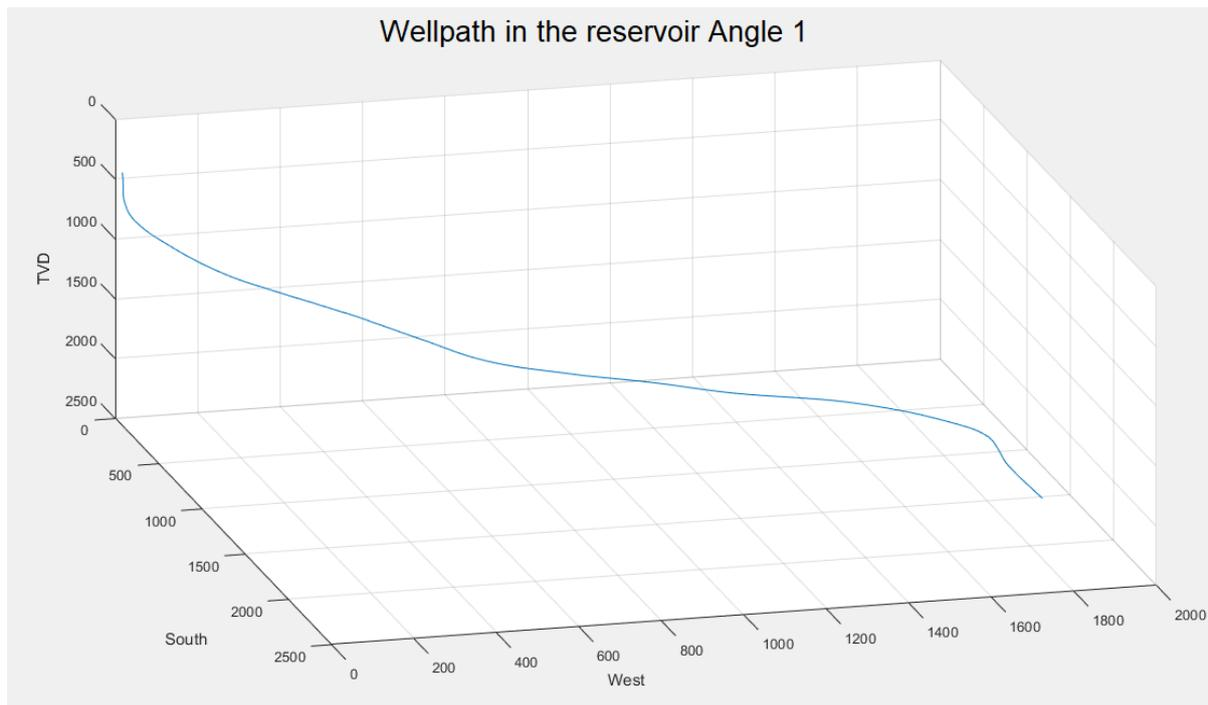

Figure 4-10; A 3D model of the wellpath in the reservoir. The camera is angled to give a top-down view from the side of the well. Showing the angle that give the longest possible representation of the well.

The pathing of the well is shown in the figure [Figure 4-8]. In the 17 ½” section a Leak of test (LOT) was performed in the casing shoe. Probably due to a poor cement job the formation integrity test (FIT) leaked off at a much lower pressure than was expected (Figure 4-5). Since the leak of pressure was so low, it was expected the pressure had leaked off into micro annulus in the cement and fractured the formation shallower than the shoe depth. It was then decided to perform a new cement squeeze to seal the micro annulus. It took two attempts before reaching sufficient pressure on the FIT.

When RIH the 9 5/8” liner into the 12 ¼” section, a miscommunication led to the mixing of a heavier mud than was safe to proceed with. This was discovered and pumped out of hole until they regained stable returns.

Upon reaching target depth and completing the 8 ½” section of the well, the setting of the 7” casing began. Problems were experienced early with establishing returns. A previously unidentified loss zone was discovered in the connection shoe to the previous 9 5/8” liner. Equipment not available on the platform needed to be ordered to seal the loss zones. Because of the sealing procedure several runs regarding cement squeezing and new LOT’s had to be

performed. The cleanup runs after these operations were not enough, and complicated later operations. New obstructions in the well were created that lead to miss-runs, and new cement squeezing had to be performed.

4.2 Case 2 - 33/12-B-17A

Well name	33/12 -B-17 A
Field	Statfjord
Objective	Oil producer and gas producer
Available data:	EOW and Limited RTDD
Entered date	01.11.2006
Completed date	08.08.2007
Time distribution	
○ 8" section	01.11.2006 – 09.11.2006
6" section	01.02.2007 – 10.02.2007
6" section sidetrack	04.08.2007 – 08.08.2007
Total depth mMD	4569 m
Errors	- Washout - Directional control
Failures	- Kill well - Plug & Abandon - Technical sidetrack

Well 33/12-B-17A was sidetracked from an older pre-existing well (Figure 4-11). The old well was probably completed in the 70's or the 80's as an oil producer but was plugged and abandoned as the production entered its tail face and it no longer was lucrative to continue production. The well was then in 2006 re-opened presumably to increase production by reaching potential undiscovered hydrocarbons. RTDD and EOW report from the original well is unfortunately not available, but an EOW and some of the RTDD from the new well are. Well 33/12-B-17A was chosen for case study because of its more modernized final well report and the availability of the RTDD.

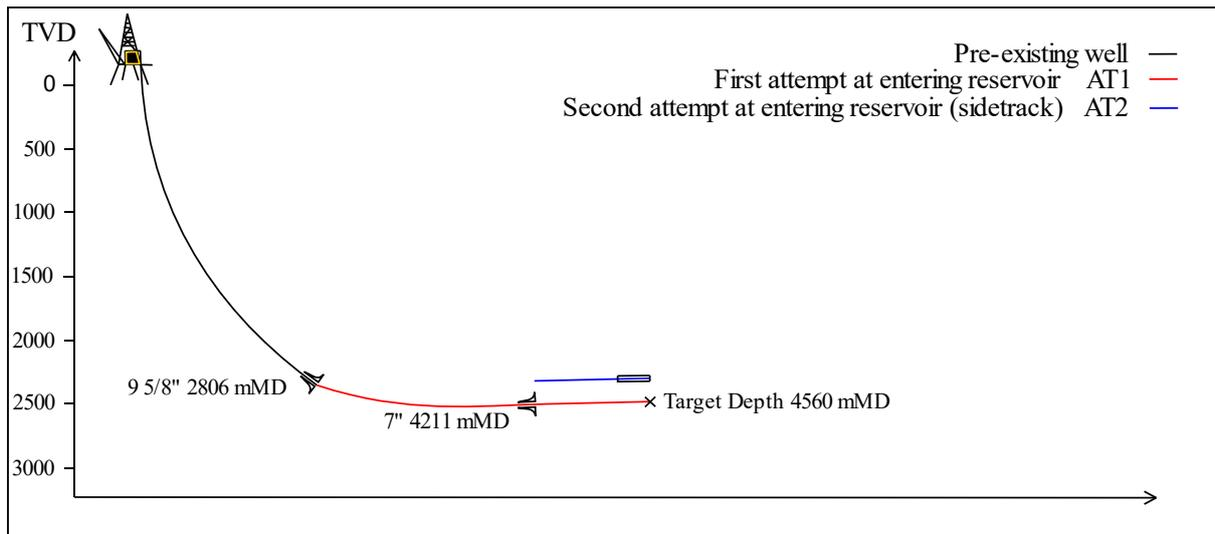

Figure 4-11; Pathing of Well 34/10 C-47

4.2.1 8 ½” Section

Well 33/12-B-17A was drilled out of the pre-existing well. Whipstock was set at 2806 mMD and an 8½” section was drilled to 4211 mMD in one run. 7” liner was set. A temporary plug was set at 489 mMD and the well was temporarily plugged and abandoned (P&A).

4.2.2 6” Section 33/12-B-17AT1

On February 01, 2007, three months after the P&A the plug was removed, and the well was drilled to 4560 mMD with a 6” bit. The well was later underreamed with a 7 ½” bit. After experiencing washout while underreaming they were not able to run the screens to target depth and was forced to cement back to the 7” liner. The well was then temporarily P&A for six months.

4.2.3 6” Section sidetrack 33/12-B-17AT2

When the well was opened 6 months later the plug was pulled and drilling could proceed. A new sidetrack was made at 4280 mMD. This new sidetrack was named 33/12-B-17AT2. The hole was first drilled with a 4 ¾ pilot hole, before widening the well with a 7” reamer. When running the Ream-Wing into the hole, the BHA got hung up at 4280m when entering the sidetrack. Circulation with an added lubricant and rotation of the reamer was enough to work the BHA through the section. When the well was about to enter the reservoir, the bit began to build at a higher angle than anticipated. The angle swayed between 1.42deg/m and 1.1deg/m dependent on the firmness of the formation they were experiencing at the time. Even when

the BHA became directionally unstable, communication with the tool was maintained and it was possible to continue drilling with a low Weight on Bit (WOB). This was only possible while drilling with a very low rate of penetration (ROP). As the bit entered a firmer formation the inclination dropped to -1deg/30m. It was then possible to increase WOB and ROP increased.

Upon reaching TD the hole was circulated bottoms up several times to clean out any residual cuttings. The BHA was then POOH immediately and the screens were set successfully.

4.3 Main failures

4.3.1 Loose formation

Through many parts of the well, and through several different lithology groups, loose formation was encountered. In some cases, this was manageable but in other cases it was not and lead to significant amounts of NPT. The operation was colored by this fact, and it shows in the drilling data. When POOH it was important to return to TD as soon as possible when running casing, but especially important when running screens. This was in fear of the hole collapsing while the string was out of the hole, and it was harder to circulate the hole.

4.3.2 Sidetrack

The sidetrack that caused the new section of the well 33/12-B-17 AT3 was a direct result of washout in the well. It was not possible to run production screens to target depth, and it was therefore decided that a sidetrack was the best solution. As we can see in (Figure 4-12), most of the activities following the sidetrack are listed as “Downtime”, or in other words NPT. This is not entirely correct. A more fitting term would be unscheduled operations. The operations that followed the sidetrack were not taken into account and are therefore considered lost time. Had the 33/12-B-17 AT2 been a success it is possible the amount of NPT, of unscheduled operations, would be more than halved.

4.3.3 Directional Control

During the last section of the well it became difficult to keep the bit directionally stable. This is partially contributed to the loose formation in combination with a PDC bit. It is also mentioned in the EOW rapport that the particular BHA that was used during this section of

the well is not recommended for future sections in similar formations that exceed 3-500 meters.

The loosens of the formation increased the ROP to a point where the inclination became hard to control. If the formation was solid the BHA had no trouble following the intended path, but when the ROP increased it began to build at a much higher angle than anticipated. Even when the WOB was decreased to almost zero it was hard to maintain the intended wellpath.

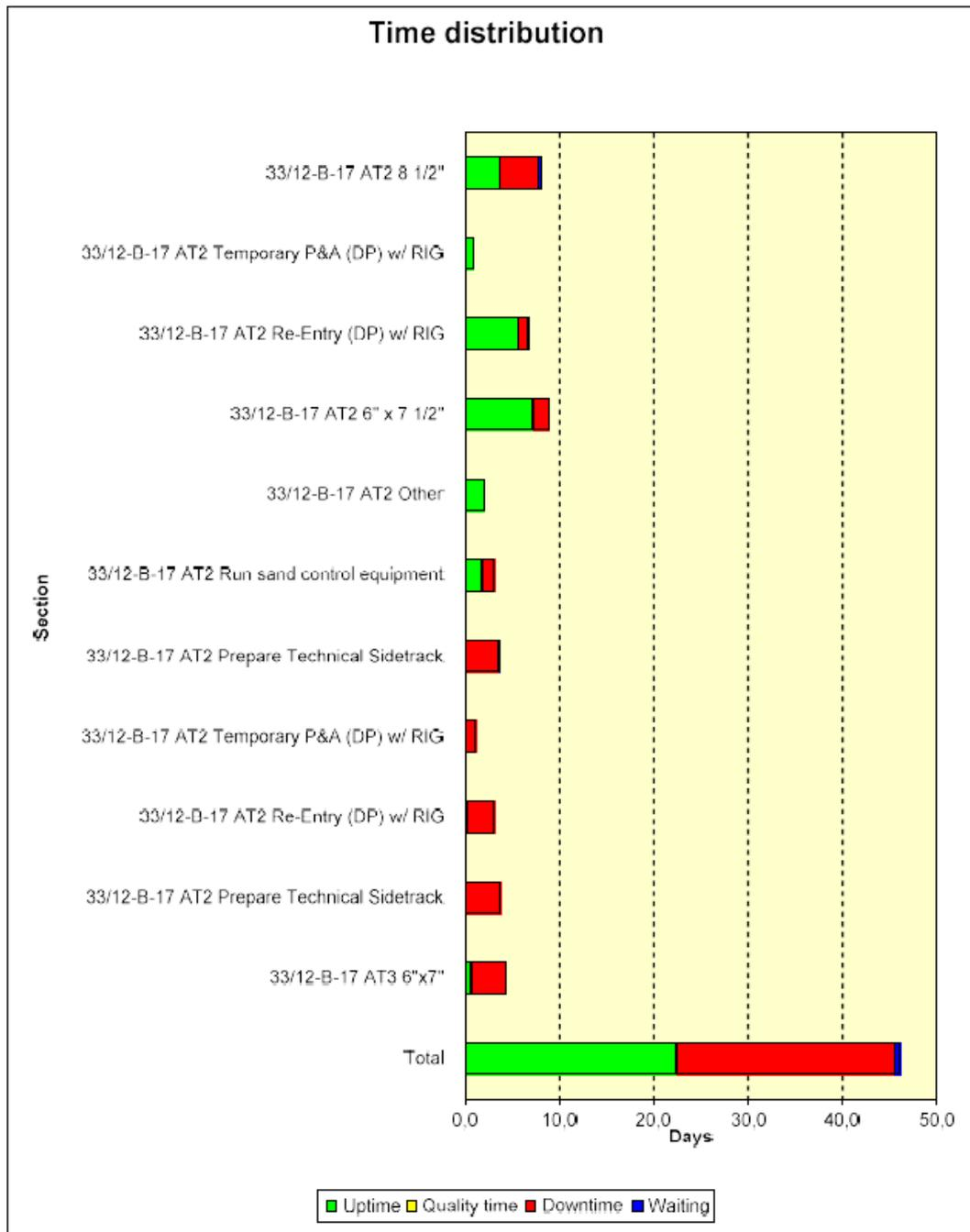

Figure 4-12; Time distribution during the Well 33/12-B-17 operations

NO 33/12-B-17 A AT2, NO 33/12-B-17 AT3

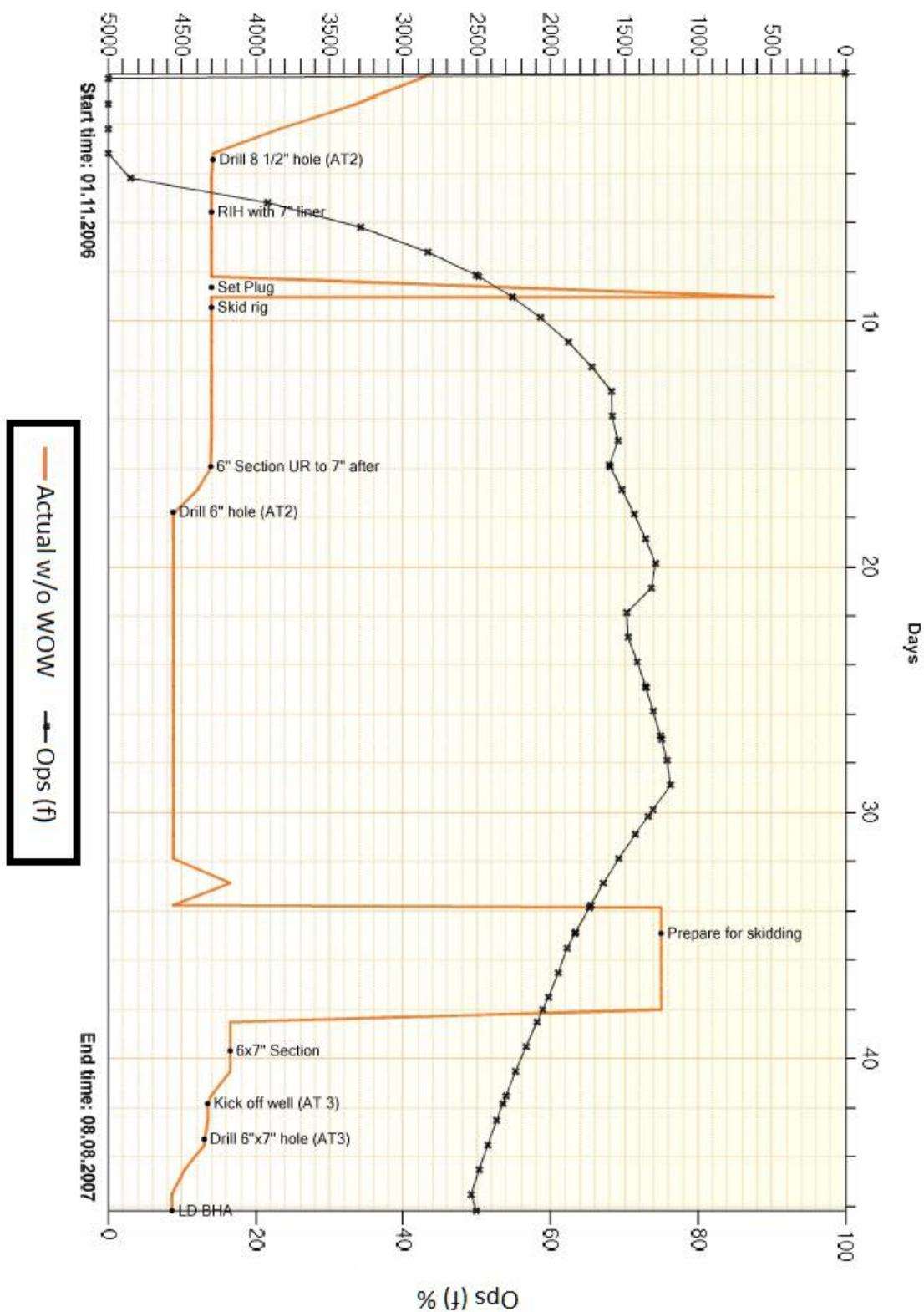

Figure 4-13; Figure representing the time distribution without the effects caused by weather and/or other logistical interruptions.

5 Discussion

5.1 Directional control

5.1.1 Case 1

To find the specific cases where lack of directional control was the leading cause of the failures investigated, a number of wells where this was not the case were also investigated as a natural process of collecting data. This provided useful information and provided credibility to the cases. It also helped showcase other cause and effect relationships between failures.

Case 1 had few problems that were caused by a lack of directional control. It did, however have multiple of other failures that took place and was the well that by far had the most complete data and EOW reports.

The first major failure in Case 1 occurred when the drill string got mechanically stuck when a combination of drilling fluids that were not compatible were mixed and put in the hole. This is clearly a case of human error since the fluids were never supposed to be mixed in the first place, and the decision to do so took place before it was even put in the hole. Nevertheless, it is important to mention since it shows the correlation between the error and NPT.

5.1.2 Case 2

In Case 2 problems regarding directional control was experienced in the 6" section. These are largely contributed to the very loose formation in combination with the use of a PDC bit. The BHA was later regarded as unsuitable for longer sections in terms of directional control in any formation regardless of loosens. This indicates that the problems were not only formation based, but also equipment based. As depicted in Figure 4-11 the reservoir was entered twice. The failures and experiences in the first attempt shaped the approach and execution of the second one.

The drillers experienced a tough decision when entering the reservoir in AT2. When the BHA became directionally unstable, an option to POOH to correct the problem and consider changing to a rock bit with superior capabilities in loose formations should be considered. The high risk of collapse or problems re-entering the hole were deemed too great considering the current well was a result of a sidetrack because of these exact problems. Therefore, drilling continued with the unstable BHA.

The considerations regarding these problems is evident in the speed at which screens was run to TD when the well was finished. In the EOW report it is stated the decision to continue drilling was made because there was still communication between the driller and the tool. It was therefore possible to use the concepts of collars and stabilizers to steer the bit towards target depth. This was only possible since the azimuth angle of the tool was in the correct position when the it failed. As an extra precaution when executing the second attempt a pilot hole was drilled. It ensured that target depth could be reached and created a path for the reamer to follow. This probably mitigated some of the problems regarding directional control the were experiencing.

5.1.3 Poor hole cleaning

Several events can be associated with poor hole cleaning.

Especially in the 12 ¼” section in first well, they experienced severe NPT caused by mud leaking into the formation.

Both in the 17 ½” and the 12 ¼” section they experienced problems squeezing the cement below the previous casing shoe. This later led to Loss of circulation. In both sections it was concluded that the reason for the subpar cement job was improper hole cleaning. After cement squeeze in the 12 ¼” section, proper circulation of the hole was not performed.

5.1.4 Logistics

The data did not contain much information about logistics of the operations. As such it does not become clear in the rapport what the reasons are for the lengthy delays between the P&A's. Some points indicate that they are purely logistical and other that it was due to the weather. It took three to four months before the rig was skidded back and drilling started again. This suggest that it was more than just WOW. There was also significant NPT during operations when the rig was P&A without any explanations. This could suggest that the rig was needed elsewhere that took priority over completing well 33/12-B-17A.

It is worth to mention that only the first P&A is not considered to cause the project any NPT but the second one does. This indicates that the first P&A was a planned before drilling started, while the second happened due to unforeseen events. Most events that took place

after the side-tracked 6" segment, are in the EOW rapport considered as unplanned operations. This includes the second P&A. The well needed to be completed before a specific time in order to avoid the temporary P&A, but because of the sidetrack in the 6" section this deadline was not met. If this was because of logistics or weather is still no clear.

Most likely the reason was a combination of these suggestions. The rig chose to P&A while WOW. And instead of having an un-operational rig during these downtimes, it was relocated to another site.

5.1.5 Opportunity cost

Because of the high potential income associated with producing a well and the high cost of developing an oil field, NPT is often the large source of avoidable expense. Hydrocarbon production is a high-investment / high-income business. Human resources provide a large expense, but so does the owning and maintaining of high-end equipment. That is why it is critical to complete the development wells as safely and efficiently as possible. The development of a new well cannot start until the previous is complete, so if a well is delayed it effects all future wells that could be drilled in that time. This brings up the concepts of opportunity cost. When having multiple options and choosing one forgoes the other options, the opportunity cost is the loss of those options. In the oil industry this represents amongst other things which wells to drill. It will always be better to start with the safest and most efficient wells and work towards the riskier ones. Not only because of the opportunity cost, but also because a high income now can fuel future investments better than a high income later. This holds true for many industries, but especially the oil industry since it is such a high-investment / high-income activity.

5.1.6 Progress in drilling technology

Of the wells that were available for analysis, only a select number had available EOW rapports and logging data. Because of this the selection was limited when choosing wells to analyze. The wells discussed in this work are from different periods of time in terms of available technology. But this has provided an opportunity to study how similar problems were approached with the available resources at that time.

In new wells it is very rarely used rock bits, but in the last section of well (NO 33/12-B-17 A) they were forced to switch from using PDC bits to a rock bit in order to rectify some of the

steering problems they were experiencing. This illustrates a very important point on how wells have changed. On older wells rock bits were often run in combination with mud motors. When wells became longer to reach less accessible hydrocarbons, the rock bit started to become a liability. Rock bits got worn out too fast and pulling out of a long hole to switch bit became time consuming.

5.2 Self-evaluation

5.2.1 Quality of data

The primary challenge in this thesis has been the lack and quality of available data. Initially it seemed that there was an abundance of drilling data from many different operators in the North Sea. When investigating the available data further, it soon became apparent that we were not as spoiled for choice as it might have seemed. Firstly, most of the data was not even readable without the necessary software used by the corresponding operator providing the drilling data. Amazing work was done by students at NTNU in creating a program that could read a large percentage of the well data and make it readable for everyone.

Some of the data was also censored. Either partly removed or blacked out and made unreadable. This could be dates, data or people. Making it harder to establish a true recreation of the events that took place. There was also no information whether something was censored or just missing, furthering the difficulties.

The biggest problem was that a lot of the data was simply incomplete. In some cases, only a partial End of Well report was provided with no corresponding data. This made the EOW report almost useless without any real data to support it. The opposite was also very common, a partial complete set with data with no corresponding EOW report explaining the events that took place during operations.

Any or all of these discrepancies were so common that there were only a handful of complete datasets available to this thesis. And from these, the ones that had relevance to the problems investigated by this thesis, are presented here.

5.2.2 Quality of model

The goal of this thesis is to use real-time drilling data to acquire knowledge about the drilling process and use the experiences of the past to improve upon drilling operations in the future. The method of solving the problem presented in this work started by looking through sets of data and finding the ones that best explored said problems. The approach selected for this thesis was followed as closely as possible. Since resources were limited my work suffered in some areas. The model could have been improved so that the errors and failures were better categorized. Then it could have been improved upon indefinitely in the future as more symptoms were discovered and put more weight behind the claims that certain symptoms lead to specific failures. Such a model would be a useful tool in future theses.

5.2.3 Future improvements

A realistic way to improve upon this work is to enhance the model. With a stronger model and a greater knowledge of Matlab and other computer programming languages a streamlined way to integrate new data-sets could be achieved. Even if the model was to be improved, this would be useless unless more data-sets were made available. At the point of writing this thesis the availability of new data-sets is limited. In order to access new ones the industry must be willing to provide the students that are about to join them with the means to learn and improve themselves.

6 Conclusion

If a tool does not explicitly inform that directional capabilities are lost, it can be difficult to detect if lacking directional control is the source of the error. Therefore, other sources to the failures are often blamed instead of directional control. From the work done in this thesis, a few of the failures discovered could be a direct result of the lack of directional control.

From the work done on this master thesis the following conclusions can be made;

- Lack of directional control can lead to many other failures during drilling. The position of bit and its direction is critical for the success of the well.
- Lack of directional control can be a direct cause to unwanted proximity to other wells which can lead to backtracking and sidetracking.
- Lack of directional control can cause the well to entering unwanted lithologies. The unexpected pressure change can cause kick, blowout or well instability.
- Lack of directional control is not always the source of a failure even if it is directly involved. Multiple sources can contribute in unison to create a complex failure pattern.

7 References

Bourgoyne, A. T., et al. (1991). Applied drilling engineering, Society of Petroleum Engineers Richardson, TX.

Brechan, B. a., et al. (2017). Drilling, Completion, Intervention and P&A - design and Operations. Trondheim, NTNU - Department of Petroleum Engineering and Applied Geophysics.

Jr., A. T. B., et al. (1986). Applied Drilling Engineering.

Lubinski, A. and H. B. Woods (1953). Factors affecting the angle of Inclination and Dog-Legging in Rotary Bore Holes. Drilling and Production Practice. New York, New York, American Petroleum Institute.

Miska, S. and A. Lubinski (1987). "Developments in petroleum engineering. Volume 1: Stability of tubulars-Deviation control."

Skalle, P., et al. (2013). "Detection of Symptoms for Revealing Causes Leading to Drilling Failures." SPE Drilling & Completion **28**(02): 182-193.

Skalle, P., et al. (2016). Detection of Failures and Interpretation of Causes During Drilling Operations. Abu Dhabi International Petroleum Exhibition & Conference. Abu Dhabi, UAE, Society of Petroleum Engineers: 13.

Wilson, G. (1968). "An improved method for computing directional surveys." Journal of Petroleum Technology **20**(08): 871-876.

8 Abbreviations

BHA	Bottom hole assembly
BHP	Bottom hole pressure
BOP	Blow out preventer
DC	Drilling Collar
DL	Dog leg
DLS	Dog leg severity
ECD	Effective Circulation Density
EOW	End of well
EOWR	End of well report
FIT	Formation integrity test
LC	Lost Circulation
LOT	Leak of test
MD	Measured depth
MPD	Managed Pressure Drilling
MWD	Measure While Drilling
NPT	Non-productive time
P&A	Plugged and abandoned
RIH	Run in hole
ROP	Rate of penetration
RSS/3DRSS	3D rotary steerable system, or push of assembly
RTDD	Real time drilling data
SG	Standard Gravity
SPP	Surface pump pressure
TD	Target Depth
TVD	True Vertical Depth
WOB	Weight on bit
WOW	Waiting on weather

9 Appendix A

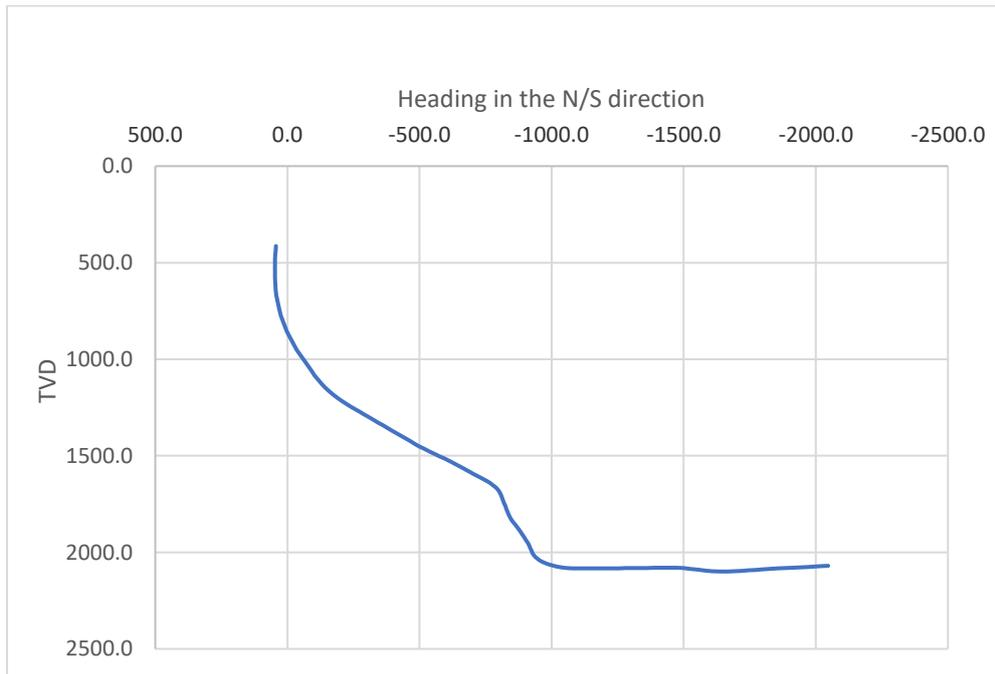

Figure 9-1 Figure shows the horizontal displacement of the well in the North/South direction. In this case the well was angled south, thereby the negative numbers on the diagram.

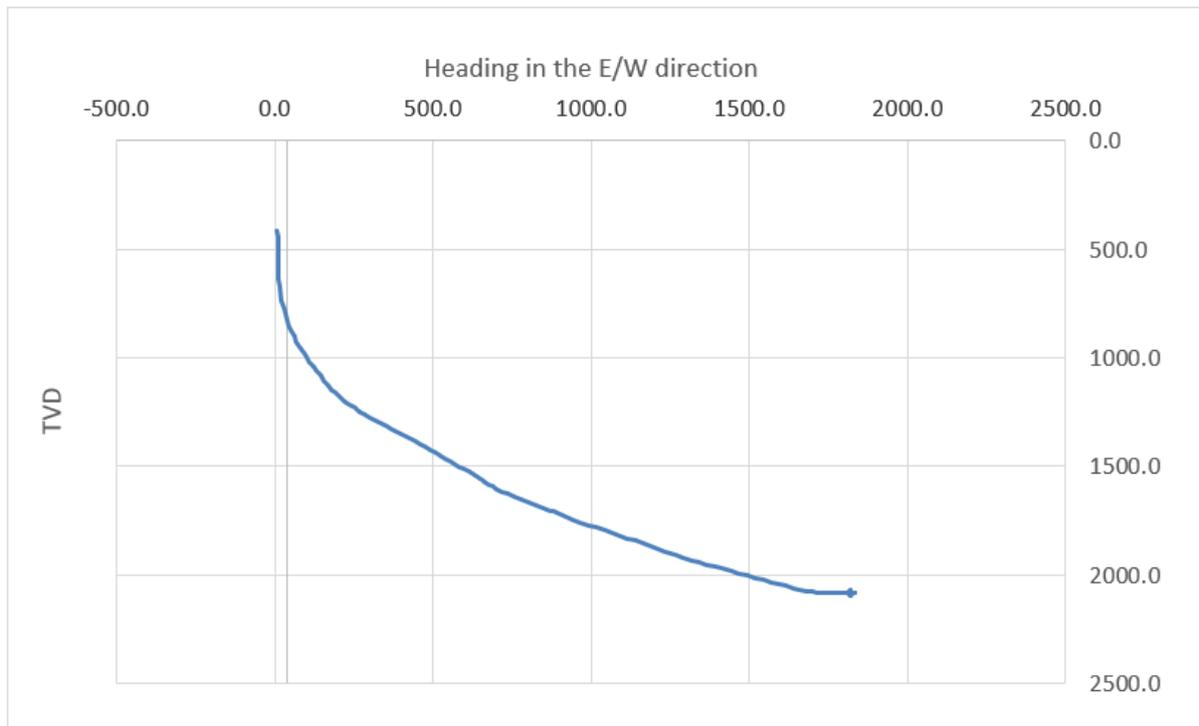

Figure 9-2 This diagram shows the pathing of the well in the East/West direction

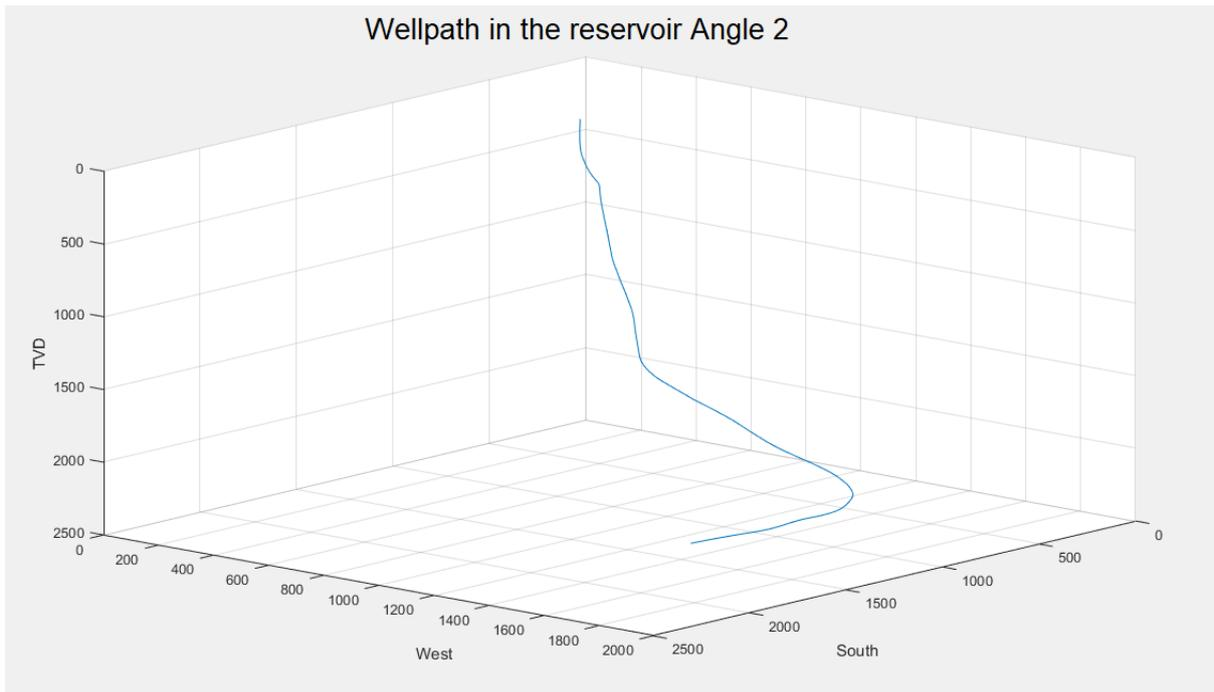

Figure 9-3 A 3D model of the wellpath in the reservoir. The camera is angled at a top-down view at the end of the well. The angle gives a less impression of the length of the well but shows more clearly how the pathing changes as it lines up in order to enter the reservoir.

10 Appendix B

WELLBORE_ID	Depth MD [m]	Incli deg	Azim deg	Depth TVD [m]	N/S [m]	E/W [m]	D-Leg [deg/30m]
NO 34/10-C-47	414.0	2.99	27.33	413.8	43.6	8.3	1.35
NO 34/10-C-47	441.5	2.60	20.39	441.3	44.8	8.9	0.56
NO 34/10-C-47	454.5	2.43	16.81	454.3	45.4	9.1	0.53
NO 34/10-C-47	482.5	1.74	0.80	482.3	46.4	9.2	0.96
NO 34/10-C-47	510.0	0.69	19.17	509.8	46.9	9.3	1.21
NO 34/10-C-47	524.5	0.22	20.92	524.3	47.0	9.4	0.97
NO 34/10-C-47	537.0	0.32	163.92	536.8	47.0	9.4	1.23
NO 34/10-C-47	565.0	1.19	162.66	564.8	46.7	9.5	0.93
NO 34/10-C-47	580.0	1.30	136.21	579.8	46.4	9.6	1.16
NO 34/10-C-47	608.0	3.15	133.87	607.7	45.7	10.4	1.98
NO 34/10-C-47	608.0	3.15	133.87	607.7	45.7	10.4	1.98
NO 34/10-C-47	640.0	4.68	136.50	639.7	44.1	12.0	1.44
NO 34/10-C-47	670.0	8.63	137.36	669.5	41.6	14.3	3.95
NO 34/10-C-47	740.5	12.90	141.97	738.7	31.5	22.8	1.85
NO 34/10-C-47	777.0	15.66	141.67	774.1	24.4	28.3	2.27
NO 34/10-C-47	804.5	18.40	141.49	800.3	18.1	33.3	2.99
NO 34/10-C-47	832.2	20.76	141.19	826.4	10.8	39.1	2.56
NO 34/10-C-47	859.9	22.85	141.02	852.1	2.8	45.6	2.27
NO 34/10-C-47	886.5	25.12	140.50	876.4	-5.5	52.4	2.57
NO 34/10-C-47	914.4	26.87	140.30	901.6	-15.0	60.2	1.88
NO 34/10-C-47	941.5	29.36	138.75	925.8	-24.8	68.6	2.83
NO 34/10-C-47	969.5	31.58	137.20	949.6	-35.2	78.0	2.56
NO 34/10-C-47	996.7	34.66	136.77	972.3	-46.1	88.1	3.41
NO 34/10-C-47	1024.7	36.45	135.69	995.2	-57.8	99.4	2.03
NO 34/10-C-47	1052.2	35.08	136.10	1017.4	-69.4	110.6	1.52
NO 34/10-C-47	1079.8	35.16	136.05	1040.0	-80.8	121.6	0.09
NO 34/10-C-47	1106.2	35.79	135.02	1061.5	-91.6	132.6	0.71
NO 34/10-C-47	1133.7	37.89	135.60	1083.5	-103.3	144.2	2.32
NO 34/10-C-47	1161.4	39.65	136.17	1105.1	-115.7	156.2	1.95
NO 34/10-C-47	1189.0	42.03	137.33	1126.0	-128.9	168.6	2.71
NO 34/10-C-47	1215.4	45.30	137.61	1145.1	-142.3	180.9	3.73
NO 34/10-C-47	1243.8	47.27	138.81	1164.7	-157.6	194.6	2.27
NO 34/10-C-47	1271.3	49.69	137.67	1182.9	-173.2	208.1	2.8
NO 34/10-C-47	1298.5	52.13	139.28	1200.1	-189.0	222.1	3.02
NO 34/10-C-47	1326.1	54.92	139.09	1216.5	-205.8	236.6	3.04
NO 34/10-C-47	1353.6	57.82	137.25	1231.7	-222.9	251.9	3.57
NO 34/10-C-47	1381.2	58.87	136.92	1246.2	-240.1	267.9	1.18
NO 34/10-C-47	1408.5	60.94	135.05	1259.9	-257.0	284.3	2.89
NO 34/10-C-47	1435.9	61.37	134.56	1273.1	-274.0	301.3	0.66
NO 34/10-C-47	1463.4	60.53	135.34	1286.5	-290.9	318.3	1.18
NO 34/10-C-47	1480.3	60.44	136.11	1294.8	-301.4	328.5	1.2
NO 34/10-C-47	1523.9	60.78	134.65	1316.2	-328.4	355.2	0.9
NO 34/10-C-47	1548.7	61.58	134.66	1328.2	-343.7	370.7	0.97
NO 34/10-C-47	1578.5	61.01	133.54	1342.5	-361.9	389.4	1.14
NO 34/10-C-47	1605.3	60.63	134.12	1355.5	-378.0	406.3	0.71
NO 34/10-C-47	1634.6	60.73	135.40	1369.9	-396.1	424.5	1.14
NO 34/10-C-47	1662.3	60.99	135.63	1383.4	-413.3	441.4	0.36
NO 34/10-C-47	1689.6	60.65	134.74	1396.7	-430.3	458.2	0.93
NO 34/10-C-47	1717.1	60.58	135.08	1410.2	-447.1	475.2	0.33

NO 34/10-C-47	1744.3	60.34	136.29	1423.6	-464.1	491.7	1.19
NO 34/10-C-47	1771.6	58.95	139.38	1437.4	-481.5	507.5	3.31
NO 34/10-C-47	1798.9	60.55	140.11	1451.2	-499.0	522.0	1.89
NO 34/10-C-47	1824.5	62.27	141.64	1463.4	-516.9	536.9	2.56
NO 34/10-C-47	1853.8	62.63	141.68	1477.0	-537.4	553.1	0.37
NO 34/10-C-47	1881.1	62.97	141.99	1489.4	-556.4	568.0	0.48
NO 34/10-C-47	1908.4	63.10	142.05	1501.8	-575.6	583.0	0.15
NO 34/10-C-47	1936.5	62.64	141.07	1514.6	-595.2	598.6	1.05
NO 34/10-C-47	1963.9	61.80	140.06	1527.4	-613.9	614.0	1.34
NO 34/10-C-47	1991.2	60.63	140.89	1540.5	-632.4	614.0	1.51
NO 34/10-C-47	2017.8	59.75	140.88	1553.8	-650.3	614.0	0.99
NO 34/10-C-47	2045.6	59.71	140.31	1567.8	-668.9	614.0	0.53
NO 34/10-C-47	2054.3	59.59	140.49	1572.2	-674.6	614.0	0.68
NO 34/10-C-47	2074.6	59.82	140.39	1582.4	-688.2	614.0	0.36
NO 34/10-C-47	2101.0	61.69	140.25	1595.3	-705.9	614.0	2.13
NO 34/10-C-47	2118.0	63.34	138.18	1603.2	-717.3	614.0	4.36
NO 34/10-C-47	2147.1	64.17	132.77	1616.1	-735.9	614.0	5.07
NO 34/10-C-47	2175.3	64.10	127.79	1628.4	-752.3	614.0	4.77
NO 34/10-C-47	2201.6	63.43	122.93	1640.0	-765.9	614.0	5.03
NO 34/10-C-47	2229.1	62.86	118.28	1652.4	-778.4	614.0	4.59
NO 34/10-C-47	2256.7	62.77	113.47	1665.0	-789.1	614.0	4.64
NO 34/10-C-47	2285.9	62.40	107.61	1678.5	-798.2	614.0	5.35
NO 34/10-C-47	2312.8	62.74	102.61	1690.9	-804.4	614.0	4.94
NO 34/10-C-47	2340.4	61.47	99.61	1703.8	-809.1	614.0	3.2
NO 34/10-C-47	2350.7	60.41	99.11	1708.8	-810.6	614.0	3.36
NO 34/10-C-47	2425.2	60.68	101.22	1745.1	-820.2	614.0	0.75
NO 34/10-C-47	2452.9	62.58	103.44	1758.3	-825.4	614.0	2.95
NO 34/10-C-47	2480.8	63.18	98.67	1771.0	-827.4	614.0	0.72
NO 34/10-C-47	2508.9	64.98	98.52	1783.2	-831.2	614.0	1.93
NO 34/10-C-47	2536.7	64.75	98.24	1795.1	-834.9	614.0	0.37
NO 34/10-C-47	2564.8	64.28	99.85	1807.1	-838.8	614.0	1.64
NO 34/10-C-47	2592.6	64.49	100.59	1819.2	-843.3	614.0	0.75
NO 34/10-C-47	2620.5	63.89	102.01	1831.3	-848.2	614.0	1.52
NO 34/10-C-47	2648.3	64.77	106.09	1843.4	-854.3	614.0	4.08
NO 34/10-C-47	2676.1	63.87	106.68	1855.4	-861.3	614.0	1.13
NO 34/10-C-47	2703.8	62.61	106.90	1867.9	-868.5	614.0	1.38
NO 34/10-C-47	2731.5	62.31	105.97	1880.7	-875.5	614.0	0.95
NO 34/10-C-47	2759.1	62.65	104.07	1893.5	-881.8	614.0	1.87
NO 34/10-C-47	2797.8	63.13	104.65	1911.1	-890.3	614.0	0.55
NO 34/10-C-47	2825.0	65.04	103.46	1923.0	-896.3	614.0	2.41
NO 34/10-C-47	2852.4	66.65	101.95	1934.2	-901.8	614.0	2.32
NO 34/10-C-47	2880.2	68.75	101.27	1944.7	-906.9	614.0	2.36
NO 34/10-C-47	2907.6	69.04	98.84	1954.6	-911.4	614.0	2.51
NO 34/10-C-47	2935.2	68.94	97.50	1964.5	-915.1	614.0	1.36
NO 34/10-C-47	2956.2	69.05	96.05	1972.0	-917.4	614.0	1.94
NO 34/10-C-47	2990.4	69.11	97.05	1984.2	-921.0	614.0	0.82
NO 34/10-C-47	3018.0	69.11	97.04	1994.1	-924.2	614.0	0.01
NO 34/10-C-47	3045.5	68.48	98.05	2004.0	-927.5	614.0	1.24
NO 34/10-C-47	3072.9	69.10	101.61	2013.9	-931.9	614.0	3.7
NO 34/10-C-47	3100.4	69.48	105.81	2023.7	-938.0	614.0	4.29
NO 34/10-C-47	3127.7	69.85	111.73	2033.2	-946.2	614.0	6.12
NO 34/10-C-47	3155.3	70.43	115.69	2042.5	-956.7	614.0	4.1
NO 34/10-C-47	3182.5	71.73	119.91	2051.4	-968.7	614.0	4.62
NO 34/10-C-47	3210.5	73.52	124.45	2059.7	-982.9	614.0	5.03

NO 34/10-C-47	3238.0	75.54	130.00	2067.1	-998.9	614.0	6.24
NO 34/10-C-47	3265.4	78.67	133.71	2073.2	-1016.7	614.0	5.24
NO 34/10-C-47	3292.8	82.09	139.29	2077.8	-1036.4	614.0	7.08
NO 34/10-C-47	3320.4	84.99	144.48	2080.9	-1057.9	614.0	6.45
NO 34/10-C-47	3347.7	87.40	148.71	2082.7	-1080.7	614.0	5.33
NO 34/10-C-47	3375.4	89.89	151.55	2083.3	-1104.7	614.0	4.08
NO 34/10-C-47	3402.9	91.03	153.57	2083.1	-1129.1	614.0	2.53
NO 34/10-C-47	3430.6	89.57	154.10	2083.0	-1153.9	614.0	1.69
NO 34/10-C-47	3458.2	89.74	154.95	2083.1	-1178.8	614.0	0.94
NO 34/10-C-47	3485.7	91.00	157.27	2083.0	-1204.0	614.0	2.88
NO 34/10-C-47	3513.5	91.03	157.66	2082.5	-1229.7	614.0	0.42
NO 34/10-C-47	3540.8	90.63	159.69	2082.1	-1255.0	614.0	2.28
NO 34/10-C-47	3568.2	91.31	165.67	2081.6	-1281.2	614.0	6.58
NO 34/10-C-47	3595.7	90.86	170.31	2081.1	-1308.1	614.0	5.08
NO 34/10-C-47	3623.2	90.43	172.82	2080.8	-1335.3	614.0	2.78
NO 34/10-C-47	3650.8	90.49	175.93	2080.6	-1362.7	614.0	3.39
NO 34/10-C-47	3678.3	90.46	179.92	2080.3	-1390.3	614.0	4.34
NO 34/10-C-47	3705.8	90.43	182.80	2080.1	-1417.7	614.0	3.15
NO 34/10-C-47	3733.1	91.06	184.16	2079.8	-1445.0	614.0	1.64
NO 34/10-C-47	3760.9	88.69	183.56	2079.8	-1472.7	614.0	2.64
NO 34/10-C-47	3788.2	83.82	183.78	2081.6	-1499.9	614.0	5.36
NO 34/10-C-47	3815.7	80.52	183.30	2085.3	-1527.1	614.0	3.64
NO 34/10-C-47	3843.3	80.62	183.77	2089.9	-1554.2	614.0	0.52
NO 34/10-C-47	3870.5	81.54	183.67	2094.1	-1581.1	614.0	1.02
NO 34/10-C-47	3898.1	84.45	181.96	2097.4	-1608.4	614.0	3.66
NO 34/10-C-47	3925.2	88.46	180.84	2099.1	-1635.4	614.0	4.61
NO 34/10-C-47	3953.3	92.00	180.63	2099.0	-1663.5	614.0	3.78
NO 34/10-C-47	3980.5	93.86	180.49	2097.6	-1690.7	614.0	2.05
NO 34/10-C-47	4008.3	94.89	181.28	2095.5	-1718.4	614.0	1.4
NO 34/10-C-47	4035.8	95.09	181.07	2093.1	-1745.8	614.0	0.32
NO 34/10-C-47	4063.3	95.52	181.00	2090.6	-1773.2	614.0	0.48
NO 34/10-C-47	4090.8	94.95	180.24	2088.1	-1800.6	614.0	1.03
NO 34/10-C-47	4145.8	94.72	180.10	2083.4	-1855.4	614.0	0.15
NO 34/10-C-47	4203.8	94.15	179.71	2078.9	-1913.3	614.0	0.36
NO 34/10-C-47	4255.3	93.60	179.56	2075.5	-1964.6	614.0	0.33
NO 34/10-C-47	4310.3	94.12	179.51	2071.8	-2019.5	614.0	0.28
NO 34/10-C-47	4337.6	93.98	179.22	2069.8	-2046.7	614.0	0.35

