



Norwegian University of  
Science and Technology

# Future Bridge Wing Workstation

An Ergonomic Approach to the Development  
of a Ship Bridge Wing's Workstation

**Ferdinand Oddsønn Solvang**

Mechanical Engineering

Submission date: June 2016

Supervisor: Martin Steinert, IPM

Norwegian University of Science and Technology  
Department of Engineering Design and Materials



**MASTER THESIS SPRING 2016  
FOR  
STUD.TECHN. Ferdinand O. Solvang**

**Future Bridge Wing Workstation – Future mechanical workstation**

***Fremtidens skipsbrovinge – Fremtidens mekaniske arbeidsstasjon***

The setup of the workstation at ship bridge wings have for many years consisted of a large console scattered by different buttons and devices, mounted at the center of the bridge wing and taking up most of the floor space. Today's bridge wing consoles are usually fully fixed, not allowing for any adjustments. Captains and crew members of all sizes are constrained to one setup. Also different bridge wing operations demand different working positions. This means that the crew must adjust to the workstation and not the opposite.

A Pre-master's project, executed during the fall of 2015, lays the background for this master's thesis. The pre-master's showed that a great deal of positive changes can be made, but regulations hold the evolution back. A lot of these regulations are ignored during this master's thesis, in order to be innovative and forward thinking. The master's thesis will be concentrated around the mechanical setup of the workstation, with a focus on safe and ergonomic working conditions and accommodate for different working positions. The work will be based on a technological span until 2025.

Focus areas in this master's thesis:

**Housing of devices**

- Technical solutions for adjustments
- Space for devices
  - How to fit them
  - How to place them

**Ergonomics**

- Working position
- User adjustments

**Additional matters to be discussed:**

- Health and safety regarding the workstation
- Placement of the workstation at the bridge wing

The aim is to develop high resolution prototypes that help to model and judge prospective interactions. If possible the work shall constitute the foundation or parts of an academic publication.

**Formal requirements:**

Three weeks after start of the thesis work, an A3 sheet illustrating the work is to be handed in. A template for this presentation is available on the IPM's web site under the menu

"Masteroppgave" (<https://www.ntnu.no/web/ipm/masteroppgave-ved-ipm>). This sheet should be updated one week before the master's thesis is submitted.

Risk assessment of experimental activities shall always be performed. Experimental work defined in the problem description shall be planned and risk assessed up-front and within 3 weeks after receiving the problem text. Any specific experimental activities which are not properly covered by the general risk assessment shall be particularly assessed before performing the experimental work. Risk assessments should be signed by the supervisor and copies shall be included in the appendix of the thesis.

The thesis should include the signed problem text, and be written as a research report with summary both in English and Norwegian, conclusion, literature references, table of contents, etc. During preparation of the text, the candidate should make efforts to create a well arranged and well written report. To ease the evaluation of the thesis, it is important to cross-reference text, tables and figures. For evaluation of the work a thorough discussion of results is appreciated.

The thesis shall be submitted electronically via DAIM, NTNU's system for Digital Archiving and Submission of Master's theses.

The contact person at Kongsberg Maritime Espen Strange, and at NTNU Prof. Martin Steinert.

Torgeir Weio  
Head of Division

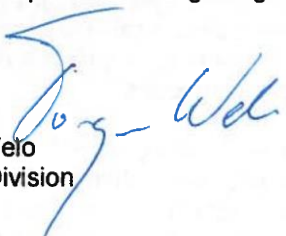

Martin Steinert  
Professor/Supervisor



## Abstract

This master's thesis originates from initial work during the summer of 2015. At the research facility TrollLabs at NTNU assigned by Kongsberg Maritime, a division of Kongsberg Gruppen, an international technological corporation.

The shipping industry is one of the world's most important trading businesses, carrying the majority of international trade items. The recreational part of shipping, such as cruises, is also a popular way to spend the holidays for many passengers across the world. A huge responsibility is resting on captains to safely navigate the ship in every condition. The design of typical workstations of the ship's integrated systems has seen very little development through the decades. During particular manoeuvres such as docking and undocking, the helmsman often find himself in awkward positions with limited access to control devices and necessary view due to poorly designed workstations. This thesis is the result of a work during the spring of 2016, which lays a foundation for a re-design of workstations at the bridge wing of the ship. Using the tools and mind-set of Design Thinking and Wayfaring along with the science of ergonomics, I have gathered knowledge and presented ideas for a user-centred workstation for a bridge wing. With an ergonomic view I have explored different working positions through an experimental study using a functional prototype and suggested solutions on ways of adjusting the workstation based on the most relevant working positions. The work has led to new knowledge about how the workstation should be designed to fulfil the ship bridge officers' needs. A suggestion for further work is presented at the end.



## Sammendrag

Denne masteroppgaven bygger videre på et arbeid som startet sommeren 2015 på TrollLabs ved NTNU og er tildelt av Kongsberg Maritime som er en del av Kongsberg Gruppen, en internasjonal teknologiorganisasjon.

Sjøfartsindustrien er en av verdens viktigste handelsindustrier, og frakter hoveddelen av internasjonale varer. Rekreasjon er også en viktig del av industrien. Mange velger å nyte ferier ombord på cruiseskip over hele verden. Et enormt ansvar hviler på kapteinen under alle forhold til sjøs. Opp gjennom tiårene har det vært lite utvikling når det gjelder utformingen av arbeidsstasjonene ved skipets integrerte systemer. Ved spesielle manøvrer som det å legge til og fra kai, er det en vanlig situasjon at styrmannen eller kapteinen må stå i kinkige posisjoner for å kunne bruke kontrollenhetene og få tilstrekkelig utsyn fra skipsbrua. Denne masteroppgaven er resultatet av et arbeid gjennom våren 2016, og legger utgangspunktet for et nytt design av arbeidsstasjonen i tilknytning til skipets broving. Ved hjelp av verktøyene og framgangsmetodene fra Design Thinking og Wayfaring sammen med kunnskap om ergonomi, har jeg samlet kunnskap og presentert idéer for hvordan en kan skape en mer brukervennlig arbeidsstasjon til skipsbroving. Med et ergonomisk perspektiv har jeg utforsket forskjellige arbeidsposisjoner en typisk bruker måtte trenge ved hjelp av en funksjonell prototype og foreslått løsninger på måter å kunne justere arbeidsstasjonen på, basert på de mest foretrukne arbeidsstillingene. Arbeidet har ført til ny kunnskap om hvordan en arbeidsstasjon bør designes for å oppfylle brooffiserenes behov. Et forslag for videre arbeid er også presentert til slutt.





## Acknowledgements

I would like to express my gratitude towards my supervisor, Professor Martin Steinert who brought me in to the research facility TrollLabs and involving me with exciting projects. Another gratitude goes to Espen Strange and Pål Gunnar Eie at Kongsberg Maritime, for both an internship during the summer of 2015 and for bringing me the challenge of this thesis.

I would also like to thank all the participants that willingly spent their time to bring useful feedback to my experiment. I also thank Erik Karlsson for useful technical assistance regarding prototyping and experimental setup.

As I am writing this, I am about to end five years of studies at The Norwegian University of Science and Technology. I must express a sincere gratitude to all the fantastic people that I have learned to know, and have shared so many great moments with. It has been an incredible journey!



# Table of Contents

<b>ABSTRACT .....</b>	<b>III</b>
<b>SAMMENDRAG .....</b>	<b>V</b>
<b>ACKNOWLEDGEMENTS .....</b>	<b>VII</b>
<b>TABLE OF CONTENTS .....</b>	<b>IX</b>
<b>LIST OF FIGURES.....</b>	<b>XIII</b>
<b>LIST OF TABLES.....</b>	<b>XV</b>
<b>ABBREVIATIONS AND DEFINITIONS.....</b>	<b>XVII</b>
<b>1 DEVELOPMENT BACKGROUND .....</b>	<b>19</b>
1.1 The Initial Challenge .....	19
1.2 Workstation Design .....	19
1.3 The Innovation Potential .....	20
1.4 Previous Outcomes .....	20
1.5 Reader's Guide .....	21
<b>2 THEORY .....</b>	<b>22</b>
2.1 Product Development .....	22
2.1.1 Fuzzy Front-End .....	22
2.1.2 Design Thinking Philosophy .....	22
2.1.3 Wayfaring as a Product Development Process .....	24
2.1.4 Prototypes .....	24
2.2 Ergonomics.....	26
2.2.1 Ergonomic Design of Workstations.....	27
2.2.2 Ergonomics on Ship Bridges .....	29
2.3 Mechanisms.....	29
2.3.1 Belt and Chain Drives.....	30
2.3.2 Rack and Pinion .....	31
2.3.3 Screw Drives.....	32
2.3.4 Pneumatic Spring.....	32
2.3.5 Expanding and Contracting Linkages .....	33
<b>3 METHOD .....</b>	<b>35</b>
<b>4 BRIDGE WING WORKSTATION PRECONDITIONS.....</b>	<b>36</b>
4.1 Definitions .....	36
4.2 Constraints.....	36
4.2.1 Task Divided Workstation.....	36
4.2.2 Type of Ship Bridge Wing.....	36

<b>5</b>	<b>WORKING POSITIONS .....</b>	<b>38</b>
5.1	Placement of the Workstation.....	38
5.2	Identification of Relevant Positions.....	40
5.2.1	Knowledge Gained After Visits.....	40
5.2.2	Relevant Positions .....	41
5.3	Further Evaluation of Working Positions .....	44
<b>6</b>	<b>CONSOLE.....</b>	<b>45</b>
6.1	Reduction of Size .....	45
6.2	Placing Devices .....	46
6.3	Technical Requirements .....	48
6.3.1	Loads .....	48
6.3.2	Health and Safety.....	48
<b>7</b>	<b>WORKSTATION ADJUSTMENTS .....</b>	<b>50</b>
7.1	Benchmarking.....	50
7.2	Desired Adjustments.....	52
7.3	Mechanisms .....	52
7.3.1	Height Adjustment.....	52
7.3.2	Width Adjustment.....	54
7.3.3	Orientation Adjustment.....	56
7.4	Evaluation.....	56
<b>8</b>	<b>FUNCTIONAL PROTOTYPE .....</b>	<b>58</b>
8.1	Desired Features .....	58
8.2	Small Scale Beta-Prototype.....	58
8.3	Full-Size Functional Prototype.....	60
8.3.1	The Prototype and its Features.....	60
8.3.2	Insights from Initial Subjective Testing.....	61
<b>9</b>	<b>EXPERIMENT.....</b>	<b>63</b>
9.1	Test Scenario .....	63
9.2	Experiment, Part I.....	64
9.2.1	Participants .....	64
9.2.2	Adjustment Features .....	65
9.2.3	Working Position .....	66
9.2.4	General Insights .....	70
9.3	Experiment Part II .....	73
9.3.1	New Experiment Setup .....	73
9.3.2	Participants .....	74

9.3.3	Body Support Features .....	75
9.3.4	Working Position .....	75
9.3.5	General Insights .....	79
<b>10</b>	<b>EXPERIMENTAL OUTCOMES.....</b>	<b>82</b>
10.1	Working Position.....	82
10.2	Adjustments.....	82
10.3	Device Placement .....	83
<b>11</b>	<b>DISCUSSIONS.....</b>	<b>84</b>
11.1	Limiting Factors of the Experiment.....	84
11.2	Further Work .....	85
11.3	Evaluation of the Process .....	86
<b>12</b>	<b>CONCLUSION .....</b>	<b>88</b>
<b>13</b>	<b>BIBLIOGRAPHY .....</b>	<b>89</b>
	<b>APPENDIX A – QUESTIONNAIRE FOR EXPERIMENT, PART I.....</b>	
	<b>APPENDIX B – QUESTIONNAIRE FOR EXPERIMENT, PART II.....</b>	
	<b>APPENDIX C – ARDUINO CODE FOR CONSOLE DEVICES.....</b>	
	<b>APPENDIX D – RISK ASSESSMENT FORM .....</b>	
	<b>APPENDIX E – PRE-MASTER’S THESIS.....</b>	



# List of Figures

Figure 1: Proposed new design for a ship bridge wing from the pre-master's thesis. ....	20
Figure 2: Generic Stage-Gate model .....	22
Figure 3: Design Thinking model.....	23
Figure 4: Wayfaring model, and probing activity.....	24
Figure 5: Different resolution prototypes. ....	25
Figure 6: Recommended heights for standing work .....	27
Figure 7: Horizontal grasping distance at the top of the workstation. ....	28
Figure 8: Chain drive with belt tightener. ....	30
Figure 9: Chain transmitting linear motion.....	30
Figure 10: Rack and pinion. ....	31
Figure 11: Lead screw drives.....	32
Figure 12: Pneumatic spring. ....	32
Figure 13: Power output of pneumatic springs. ....	33
Figure 14: Scissor lifts. ....	33
Figure 15: Straining working positions. ....	38
Figure 16: Left: Devices placed behind the user. Right: Part of view is hidden by console. The red hatched area is a blind zone.....	39
Figure 17: The most relevant field of view during docking. ....	40
Figure 18: Possible working positions. The ship bridge wing is seen from above. W: Workstation.....	41
Figure 19: Beta-prototype of functional prototype for testing working positions. ....	44
Figure 20: Testing of console during the pre-master's project .....	45
Figure 21: Author's measured standing grasping distances. ....	46
Figure 22: Maximum grasping distances.....	47
Figure 23: Benchmarking at IKEA.....	50
Figure 24: Alternative height regulation and archive shelves.....	51
Figure 25: Sliding mechanism for car seat. ....	54
Figure 26: Railway turntable. ....	56
Figure 27: Small scale prototype showing orientation, width and height adjustment .....	58
Figure 28: The functional prototype .....	60
Figure 29: Test subject during experiment. ....	63
Figure 30: How well the functions were understood. ....	65
Figure 31: How difficult the adjustments were to operate.....	66
Figure 32: Sheet given to the participants for evaluation of the positions.....	66
Figure 33: opinions of each position. ....	67

Figure 34: Position score, Experiment Part I.....	69
Figure 35: Participants trying adjustments and positions during Experiment; Part I.....	70
Figure 36: Setup for Experiment, Part II: Added body support and platform for ECDIS .....	73
Figure 37: Determining the need for support features. ....	75
Figure 38: Updated sheet given to the participants for evaluation of the positions. ....	76
Figure 39: Opinions of each position for Experiment, part II.....	77
Figure 40: Position score, combined.....	78
Figure 41: Opinions of each position, combined .....	78
Figure 42: Leaning position.....	79
Figure 43: A place to put down the coffee cup is important for captains. ....	80



## List of Tables

Table 1: Evaluation of different positions looking in different directions. ....	41
Table 2: Advantages and disadvantages with solutions for height adjustment.....	51
Table 3: Advantages and disadvantages with solutions for width adjustment .....	53
Table 4: Position values .....	66



## Abbreviations and Definitions

SBW	Ship bridge wing
ECDIS	Electronic Chart DISplay Display showing a map marking the vessels position
DT	Design Thinking
KM	Kongsberg Maritime
Thruster	Propellers that provide sideways motion to the front or back of a vessel
SMSC	Ship Modelling & simulation Centre AS, located in Trondheim
Conning display	Overview display containing heading, velocity, rate of turn, wind, propeller/thruster power and direction, rudder angle and other vital navigational information.
Workstation	The command centre of the SBW consisting of the console and its devices.
Console	The housing of the devices
Device	An object on the console, which receives input and/or gives feedback regarding control of the ship, in.eg. in relation to manoeuvring of the ship, communication, or on-board systems.
Captain	The ships top commander.
Mates	Different officer rankings below captain. Range from First Mate to Third Mate. (various names exist)
Aft	Sea expression meaning “backwards” or “rear”



# 1 Development Background

This master's thesis is built upon the foundation of a pre-master's project (Appendix E) that started in June of 2015 and ended the same year as a project thesis; "A Human-centred Approach to the Development of a Ship Bridge Wing". The focus has since the start of the pre-master's project been about further developing the concept of ship bridge wings (from here on referred to as SBWs). A SBW can be described as the extension of the ship bridge, which is the control and command centre of mid-sized to large vessels. A further explanation can be found in chapter 1 in the Appendix E. This master's thesis is more specifically focused on the development of the workstation at the SBW and its functions from an ergonomic and user-centred point of view, based on the outcomes of the pre-project. The work is primarily centred around the design of the workstation and to provide solutions for relevant adjustments. The thesis does not provide a final product concept in detail, but the outcomes lay a foundation for further concept development.

## 1.1 The Initial Challenge

The initial challenge brought forth by Kongsberg Maritime (KM) was very open. It lays the ground for the project on which this thesis is based on called "A Human-Centred Approach To The Development Of A Ship Bridge Wing". The task was to re-think and further develop the SBW, focusing on the design of the SBW itself and its workstation as well as the information feedback from the workstation. The project started with a focus on needfinding and benchmarking technology applicable to the SBW. This again kick-started an intensive period of immersion and prototyping. Three visits to ship bridges and a visit to the ship simulator facility SMSC in Trondheim, where several SBW stakeholders were interviewed, revealed many key pain points at typical SBWs, regarding the SBW as whole, the workstation (referred to as "console" in the pre-master's thesis) and the field of view from the SBW. More than 30 prototypes were built tested and evaluated by the end of 2015.

## 1.2 Workstation Design

As mentioned in the pre-master's thesis, SBW workstations are as the rest of the ship bridge usually custom designed to its designated ship. The user is rarely involved in the design development. Two factors influence the design; the ship owner's requirements and the strict set of regulations that dictates many details about the workstation such as size and distance between devices. This leads to several similarities between typical workstations. A typical

workstation consists of a large console that takes up most of the floor space of the SBW, which restricts the user's freedom of movement. The lack of adjustment possibilities and the layout of the devices also means that the users in many cases are left in awkward positions in order to manoeuvre the ship while at same time have the required field of view. The consoles are mainly large because they are equipped with a vast number of devices. most of these devices are not being used during operations at the SBW.

### 1.3 The Innovation Potential

The shipping industry is rather conservative, based on the visits and the stakeholders that were interviewed. The level of innovation at ship bridges is low and incremental. The conservative mind-set in the industry means that the potential for innovation should be high. However, the strict sets of regulations from the certification companies inhibit many radical changes. Many regulations are old, and without changes and updates, the room for innovation is quite confined. In this master's thesis, as well as during the whole project, the regulations have been ignored, in order to think new and have a better chance of finding valuable solutions. Although detailed regulations are ignored, highly relevant aspects such as safety and loads inflicted on the console have been taken into consideration.

### 1.4 Previous Outcomes

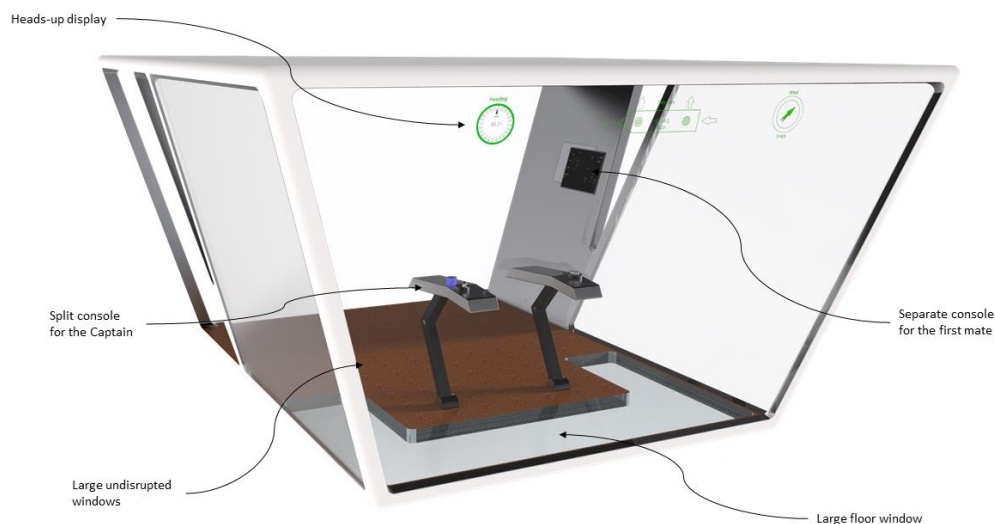

Figure 1: Proposed new design for a ship bridge wing from the pre-master's thesis.

After an intensive early product development phase, the outcomes of the pre-project anticipated a direction to go in the further development of the SBW. Figure 1 shows a vision

based on the outcomes of how the next generation of bridge wings may look like. The most important outcomes that gives the basis for this thesis are the following:

**Reduce the size of the console housing.**

Although the crew seldom change their positions during SBW operations, the floor area of many SBWs is scarce, and the way that the devices are placed, leave little freedom of motion and few possible working positions. The workstation should also be designed such that as little as possible of the field of view is obstructed.

**Provide adjustment possibilities**

Crewmembers on SBWs are as diverse as in any other profession; they come in all shapes and sizes and have different preferences. It therefore makes sense to make the console adjustable to suit different crewmembers' size and preferred position.

## 1.5 Reader's Guide

This master's thesis has a more or less chronological structure. The next chapter describes the theory behind the methods that lay ground for the work presented in this thesis, along with theory related to the solutions which are presented. After the theory, there will be a section about the author's working methods based on the theory and then the limitations and relevant definitions concerning this project are explained.

The development of the project is then described. The first phase is explorative, starting with the identification of the ideal working positions that ship bridge officers may need. Then some general discussions related to the workstation design and how to place control devices are presented. Further on comes an evaluation of the different adjustments a workstation might feature in order to make the working positons discussed possible. Solutions for these adjustments are also presented.

The next part is experimental. Ideas from the previous chapters are tested by building a functional prototype and performing tests with human test subjects. The experiment is described in two parts, where the second part is modified, based on findings from the first. The results are presented in the same chapter as the experiments.

The final section presents the outcome of the project: First the findings from the experiment and then an evaluation of the outcomes, limitations and discussion about the entire process are presented.

## 2 TheoryProduct Development

### 2.1.1 Fuzzy Front-End

When excluding the regulations from the equation, the potential of the bridge wing is vast. To explore this potential, the project started from scratch, at the very beginning of, in particular, new product development. This is often referred to as the *fuzzy front-end* (FFE) phase, a term made popular by Smith and Reinertsen (1991) and defined as the period of evolving an idea from an opportunity, to the point when the product is defined and ready for development and organizational absorption (Kim & Wilemon, 2002; Reid & De Brentani, 2004). This includes idea- and concept generation, formulation and assessment (Moenaert, De Meyer, Souder, & Deschoolmeester, 1995; Murphy & Kumar, 1997), as well as identifying opportunities, formulate product strategy and executive reviews (Khurana & Rosenthal, 1997).

The FFE is an ambiguous phase in new product development (Steinert & Leifer, 2012), with a lot of potential (Reinertsen, 1999), but can be hard to truly leverage and understand according to Kim and Wilemon (2002). It consists of a number of divergent and convergent iterations. Common philosophies and processes to manage the steps of the FFE are Design Thinking (DT) (Brown, 2008), and Wayfaring (Gerstenberg et al., 2015; Leifer & Steinert, 2014; Steinert & Leifer, 2012).

### 2.1.2 Design Thinking Philosophy

According to Tim Brown, Design Thinking is:

*"... a methodology that imbues the full spectrum of innovation activities with a human-centered design ethos. By this I [Brown] mean that innovation is powered by a thorough understanding, through direct observation, of what people want and need in their lives and what they like or dislike about the way particular products are made, packaged, marketed, sold, and supported."*(Brown, 2008, p. 1).

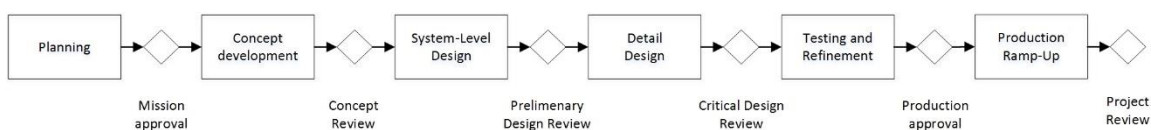

Figure 2: Generic Stage-Gate model



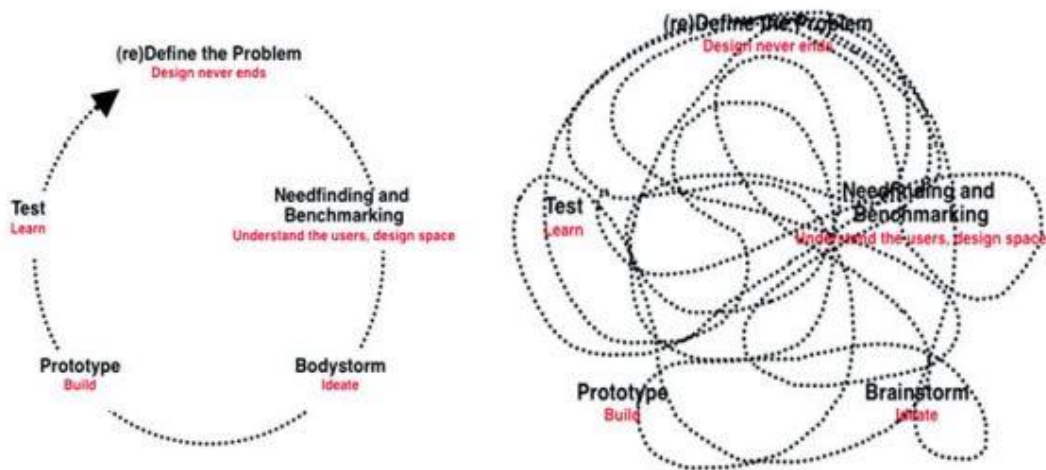

Figure 3: Design Thinking model (Meinel & Leifer, 2010a)

This methodology is applicable to almost any circumstance where humans are involved. It encourages gathering of as much knowledge as possible through multidisciplinary teams, applying multiple points-of-view concurrently (Leifer & Steinert, 2014). Where models that are more traditional such as the stage-gate model by Ulrich and Eppinger (2012) illustrated in figure 2, goes through predefined steps in a linear way, DT consists of several “spaces” or “states of mind” one loops through several times as ideas evolve and is redefined according to Brown (2008). He defines these spaces as “Inspiration”, “Ideation” and “implementation”. In the inspiration space, you explore problems and/or opportunities, and the ideation is when you diverge and generate ideas to eventually test. The implementation is when you bring the project out to the market. Brown further states that a design thinker is not necessarily a designer, although the name might be confusing. However, to fully appreciate the philosophy of DT, one should enter certain characteristics – the ability to empathize with the user, or stakeholder, understanding their needs, activities and desires; an experimental mind, asking questions and exploring possibilities; and a collaborative working environment, including multiple disciplines (Brown, 2008). The Design Thinking mentality is embraced at IDEO, an internationally recognised design firm. Meinel and Leifer (2010b) has depicted the process more elaborate, consisting of five major steps, as presented in figure 3, from "Design Thinking Research" by Meinel and Leifer (2010b, p. xiv). This figure shows a common visualization of the DT process to the left, and a more realistic DT approach to the right.

### 2.1.3 Wayfaring as a Product Development Process

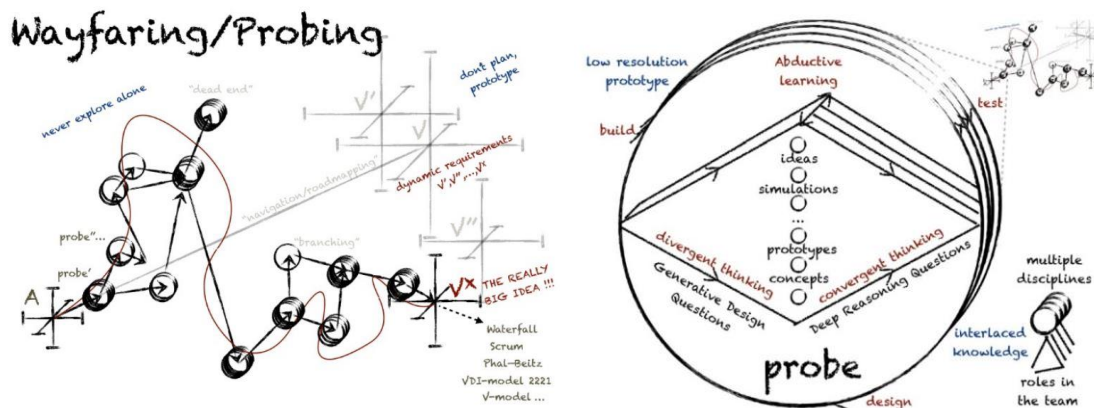

Figure 4: Wayfaring model, and probing activity. (Gerstenberg, Sjöman, Reime, Abrahamsson, & Steinert, 2015)

Wayfaring, visualized in figure 4 by Gerstenberg et al. (2015, p. 413), as a product development process first described by Steinert and Leifer (2012) in the Hunter-Gatherer Model, and later in detail by (Gerstenberg et al., 2015), works on a time basis, rather than an output or milestone basis, applied in the early pre-requirement stages. The model depicts parallel processes in multiple directions, and even dead ends. Wayfaring in front-end concept generation approaches the problem through probing, see figure 4 by Gerstenberg et al. (2015, p. 414). Probing is the act of iteratively designing, building and testing ideas through divergent and convergent activities. Prototypes works as representations of the ideas, and conveys its intentions, allowing for fast learning through interaction and visualization. In terms, these learnings will help define the requirements of the concept(s) developed to undertake previously unknown solutions. As no one can accurately define what is yet unknown, in particular in complex situations (Snowden & Boone, 2007), a Wayfaring approach has great potential when dealing with such complex challenges according to Gerstenberg et al. (2015), which is often related to radical innovations and new product development.

### 2.1.4 Prototypes

In Wayfaring and Design Thinking, prototypes are invaluable. They convey the developers' or designers' ideas and solutions both inside teams, and to users, and helps understand the situation and user perspective. A good prototype is one that communicates the desired design idea (a function, feature or any other quality) and its characteristics, in an efficient way, so that it may serve as a foundation for discussion, testing, evaluation and learning

(Lim, Stolterman, & Tenenberg, 2008). A broader more ambiguous definition is proposed by Houde and Hill (1997), saying that no matter the medium, a prototype is any form of portrayal of an idea. It may be of low or high resolution, demonstrate a critical function, an alpha- or beta prototype, an environmental model, in full-scale or small-scale, a functional prototype or as a layout proposal or CAD-model etc. and the possibilities are endless, see illustrations in figure 5. This figure also shows a low-resolution prototype, and one of higher resolution.

What kind of prototype you make depends on where you are in the process. Early on, the models are often simple, and keep functions separated, while they later become gradually more complex, implementing functions and attributes.



*Figure 5: Different resolution prototypes.*

The prototype definitions from both Lim et al. (2008) and Houde and Hill (1997) allows for a prototype to be more than a physical manifestation. As Buchenau and Suri (2000) explains, it may also be to experience the activities imposed to or by the product or service at hand, what they call “Experience Prototyping”. This is to gain first-hand encounters and knowledge, and may or may not include a physical prototype or product.

The act of probing and fast learning through iterations in the early stages of development implies fast prototyping to test particular ideas (Leifer & Steinert, 2014), thus resulting in low resolution prototypes. The ability to learn from such rapid models is the driver of the Wayfaring process according to Leifer and Steinert, and the iterations increases the likelihood of a good result (Dow, Heddleston, & Klemmer, 2009)

## 2.2 Ergonomics

*«The best posture is always the next»*

– HÅG

The quote originates from the chair brand Håg, a part of the chair group Scandinavian Business seating, and describes some key elements of the science of occupational ergonomics. According to Associate Professor Trond Are Øritsland at the Department of Product Design at NTNU (2016), human beings are created for motion and one should facilitate for varying postures in the design of products that interact with humans. In the industry, major causes of sick leave are work-related musculoskeletal complaints and disorders (Delleman & Dul, 2002). While muscles can perform well-organized dynamic work tasks easily, they quickly fatigue in static load conditions (Grandjean, 2005). Dynamic and static muscle effort are by (Grandjean, 2005) described as followed:

1. “Dynamic effort is characterised by an alternation of contraction and extension, tension and relaxation; muscle length changes, often rhythmically.”
2. “Static effort, in contrast, is characterised by a prolonged state of contraction of the muscles, which usually maintains a postural stance.”

Examples of static effort can be the case of carrying large unmanageable objects such as parcels, which inflicts fatigue on the back, or using a computer mouse and keyboard for a prolonged time, which consists of rapid finger movement causing more or less continuous muscle contractions that can also lead to fatigue. The effects of static muscle effort depend on the force momentum and duration. Consequently, the greater the force exerted by the muscle, the faster the muscle will fatigue. The immediate consequence of muscle fatigue is often experienced pain in the muscles involved, but long-term effects can be persistent musculoskeletal troubles. (Grandjean, 2005)

### 2.2.1 Ergonomic Design of Workstations

There are many recommendations towards workstation dimensions given in ergonomics textbooks. They are often based on human measurements, and can therefore be quite arbitrary. People's behavioral patterns and requirements of the work executed at the workstation are also important matters to be considered. (Vezina, Tierney, & Messing, 1992) emphasize the importance of the work task: In the case of sewing operators in static sitting positions that perform thousands of repetitions of arm movements during a day, only a few cm's deviance from an ideal sitting position might become critical. Therefore, field studies do not always confirm standard recommended dimensions of workstations.

For standing workstations, such as on SBWs, the working height is of a considerable importance regarding body strains. (Grandjean, 2005) states that the most beneficial working height for handwork while standing is between 50 and 100 mm below elbow height. The values are different for sitting working cases: An experiment performed by (Delleman & Dul, 2002) involving sewing workers, indicated that the ideal workstation height while performing sewing labour sitting down would be 50 to 150 mm above elbow height, with a surface tilted at 10° towards the worker. The average elbow height for men and women in Europe and North America is as of 2005 approximately 1070 and 1000 mm respectively. This implies that the average convenient working heights for men while standing would be 970 – 1020 mm, and 900 – 950 mm for women. There is however a difference in the recommended working height regarding the workload.

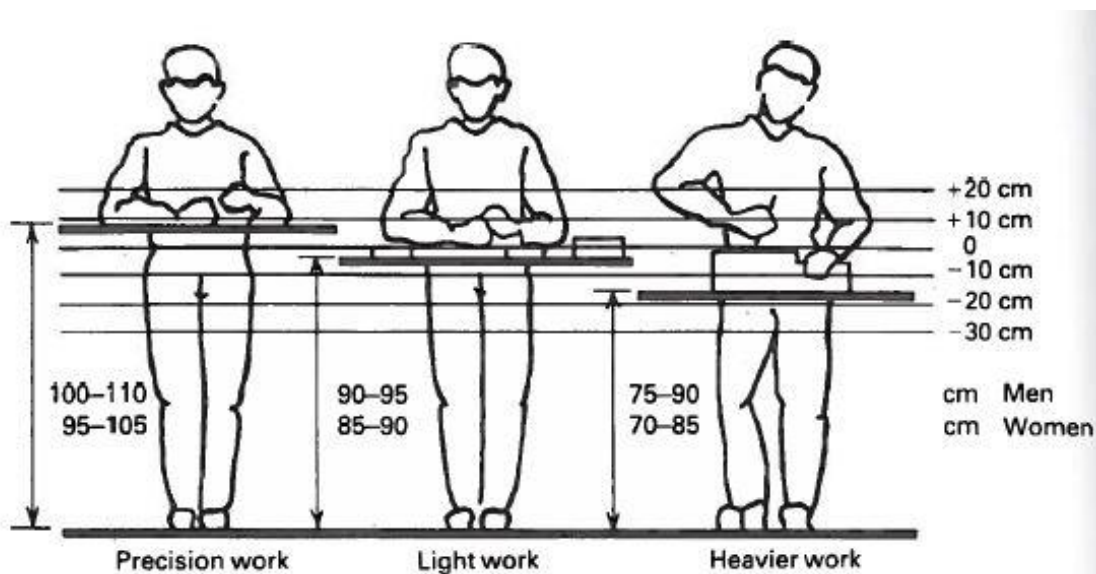

Figure 6: Recommended heights for standing work. (Grandjean, 2005), p. 54

Figure 6, taken from (Grandjean, 2005) shows guidelines for working heights during light and heavy handwork. The reference line (zero cm) represents the average elbow height above the floor, for western men and women. Examples of *Precision work* would be that of soldering or drawing, while *heavier work* involves bigger work effort where one might use the weight of the upper body, such as heavy assembly work. *Light work* represents that of operating various light tools, handles, buttons etc. where the operator might need space to move his arms in various positions. This could resemble the operations that a captain performs on a ship bridge wing.

In the design of workstations it is also important to consider the range in which the human arm moves, when placing control devices. The risk of back and shoulder pains increase if the operator must reach too far, due to excessive movement of the trunk. The operation itself will also be more energy consuming and less accurate.

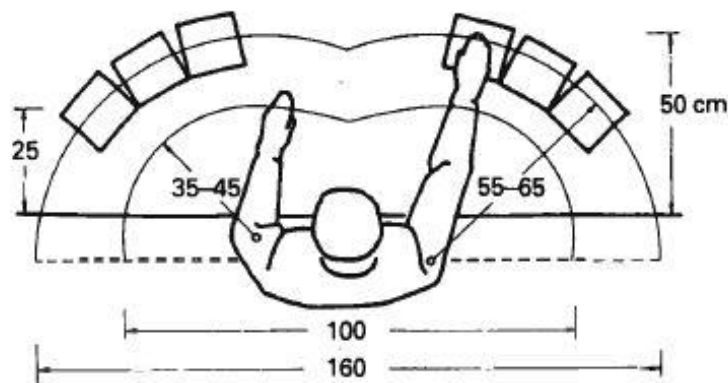

Figure 7: Horizontal grasping distance at the top of the workstation. (Grandjean, 2005), p. 67

Fifth percentile measurements have been taken on Americans to determine the grasping range. The relevant anthropometric data, are the lengths from the elbow joint to the hand and from the shoulder to the hand with the hand in a grasping posture. The figure above suggests relevant placements of working objects based on the arms' sweep radius. The range of the values include the 5<sup>th</sup> percentile below the mean size, which means they are also applicable to western men and women of less than average size.

It is important to stress that the values presented in the paragraphs above are only recommendations based on anthropometric data from (Grandjean, 2005) measured on people in Europe and North America and might not be reasonable for all workers, herein ship bridge officers. However, the values are generic and will therefore be considered regarding workstation design in this thesis.

## 2.2.2 Ergonomics on Ship Bridges

As seen through visits during the pre-master's project, ergonomics play a large role at SBWs. Research regarding ergonomics on-board ship bridges has taken place for several decades, but there is little indication that ergonomics has been fully considered still of today on many ships. Today we still see the captain in inconvenient postures on SBWs. (Wilkinson, 1974) stated that

“A recent statistical analysis of a limited number of marine accidents shows that 78 per cent were caused by human failure in many cases poor design has been the indirect cause and consideration must be given to improving the work space and working environment of the man on the ship.”

Although this study is old, many operations on ship bridges today are still manual and rely on human decision making, which emphasises the importance of ergonomics. (Wilkinson, 1974) also states that the helmsman, which is the person steering the vessel, should be considered an integral part of the vessel's manoeuvring system during manual steering. (Lützhöft, 2004) reached the conclusion that bridge systems and its users can do much better together than what either can do alone if the total system is designed correctly. (Das & Sengupta, 1996) proposed an ergonomic approach to workstation designs. They stated that using anthropometric data with the intended user population one can reach a better design by determine posture, work height, work areas, clearance and visual requirements.

## 2.3 Mechanisms

The following sections briefly describes and explains mechanical principles that might be applicable for different adjustment functions on a workstation for a SBW. The mechanical principals lay ground for the adjustment functions and mechanical concepts that are further evaluated in chapter 7.

### 2.3.1 Belt and Chain Drives

Belts and chains are most commonly used to transfer rotation from one shaft to another through pulleys or sprockets. The rotational velocity can either be the same on either shaft, or it can be reduced or increased from the driving side to the driven side. This is done by having sprockets, or pulleys of different size. Flat belts and V-belts transmit power strictly through friction. These have a tendency to slip during hard acceleration, or high velocity due to centrifugal effects. It is therefore crucial to

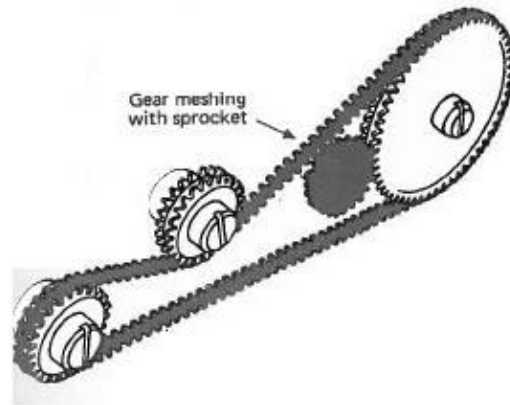

Figure 8: Chain drive with belt tightener. (Sclater & Chironis, 2001), p. 257

keep the tension high on flat belts. This can for instance be done using a belt tightening pulley such as show in Figure 8. Chains and timing belts have the advantage of transmitting power by bearing forces between positively engaged surfaces, or teeth. Tolerance on the teeth dimensions are for timing belts crucial as small differences between the belt and gears will be magnified for each tooth. Although less viable to slip, if the chain or timing belt is too loose the teeth can move in and out of mesh, which can significantly contribute to wear. It is also a problem with chains that the forces vary across the teeth of the sprocket. This means that one side of the sprockets is tight, while the other is loose. The variation of forces along chain, makes the chain prone to fatigue. (Sclater & Chironis, 2001),

Belts and chains can also be used to transmit limited translation. The driven part can be fixed to the chain and the space between the sprockets determines the range of translation. (Sclater & Chironis, 2001)

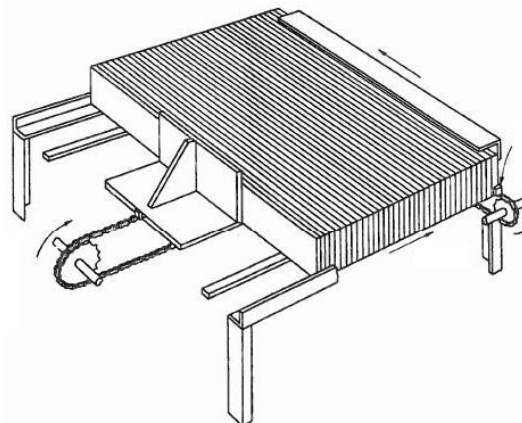

Figure 9: Chain transmitting linear motion. (Sclater & Chironis, 2001), p. 263



### 2.3.2 Rack and Pinion

A common way of transmitting rotary motion into translation is by having what is called a rack and pinion. This principle simply consists of a round gear connected with a toothed rod. This is a widely used concept in the steering transmissions of many four-wheeled vehicles. To create a linear motion, the pinion gear is fixed in all linear directions and drives the rack by rotating. The gear ratio between the linear motion of the rack and the angular motion of the pinion is only determined by the

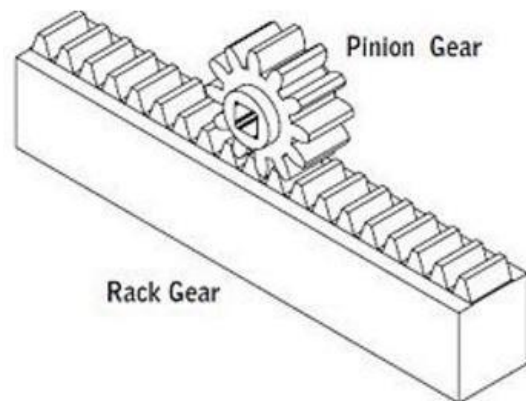

Figure 10: Rack and pinion.  
<http://www.motor-car.co.uk/suspension-types/item/14674-steering-system>

number of teeth on the pinion, or in other words its diameter. The rack can also be the fixed component, making the pinion drive itself along the rack as it rotates. This configuration is commonly found in roller coasters, and on some railways with steep inclines, on which the pinion drives the train along the track. (Sclater & Chironis, 2001), (Conwell & Johnson, 1996)

### 2.3.3 Screw Drives

Threaded rods produce linear motion by rotating around its length-wise axis through another section of threads, which in many cases is a nut. There are different configurations; either of the screw or nut can be the rotating component, and in both cases, either can also be the translating component. Screws that are intended to provide linear drive, often have specialised threads with a specific pitch that determines the gear ratio. Screw drives are commonly found in linear guides, for instance in the slides of tooling machines such as lathes and mills. Screw drives have the property of providing low gear ratios and high torque. They are precise and have no backlash. They are also in many cases self locking, meaning that there can only be a linear motion if the thread or nut is turned. (Varanasi & Nayfeh, 2004) (Sclater & Chironis, 2001).

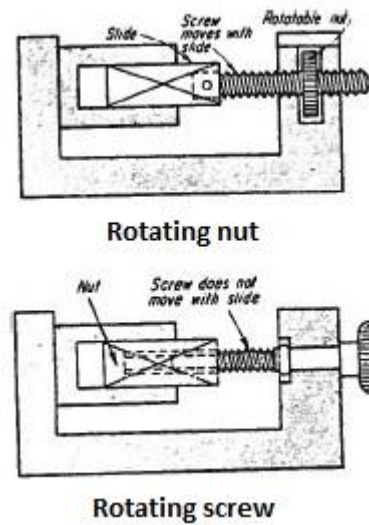

Figure 11: Lead screw drives. (Sclater & Chironis, 2001), p. 286

### 2.3.4 Pneumatic Spring

Pneumatic springs use compressed air applied on a piston to provide linear motion. Their basic principal is to store energy when the spring is compressed. When a valve is released, the compressed gas exerts force onto a piston inside the cylinder which in turn extends the spring. It is useful in many cases to provide lift.

The cylinder around the piston and piston rod is perfectly isolated, such that the gas inside cannot escape. Holes in the cross section of the piston allows the gas to move freely through the piston such that the pressure is equal on either side of the piston. Because of the piston rod, the cross section area of the piston is substantially smaller on the piston rod's side, than the other side of the piston. This means



Figure 12: Pneumatic spring.

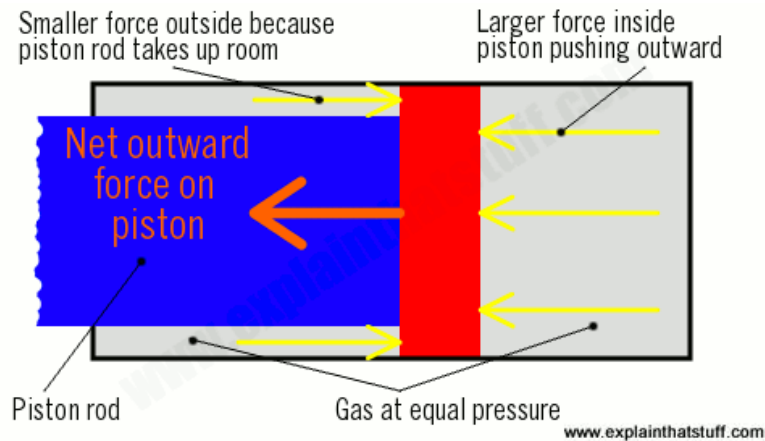

Figure 13: Power output of pneumatic springs.  
<http://www.explainthatstuff.com/gassprings.html>

that although the pressure is equal on either side, the force exerted on the outside of the piston is larger, because the pressurised gas on this side, acts on a bigger surface. This results in a net force outwards, which is illustrated in figure 13. The magnitude of the force that the spring can exert during extension is thus determined by the gas pressure and the difference between the cross sectional areas of the piston and the piston rod. (Woodford, 2015)

### 2.3.5 Expanding and Contracting Linkages

Translating motion can also be achieved by using linkages. Expanding and contracting linkages such as shown in the figure are often called “scissor lifts”. It moves the two surfaces in relation to each other in a straight line by having equal lengths on both links, joined together in the midpoint of each link. The joints on one side are exclusively rotational, while the joints on the other side can slide horizontally in relation to the latter. This makes the two surfaces

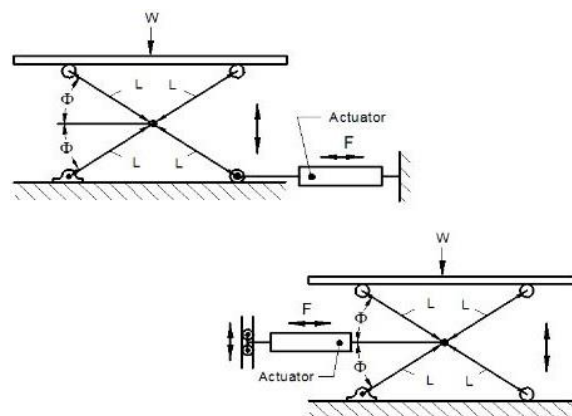

Figure 14: Scissor lifts.  
[http://www.globalspec.com/learnmore/material\\_handling\\_g\\_packaging\\_equipment/material\\_handling\\_equipment/scissor\\_lifts](http://www.globalspec.com/learnmore/material_handling_g_packaging_equipment/material_handling_equipment/scissor_lifts)

connected by the links move away from each other when the joints are pulled together and vice versa. The mechanism can be driven in combination with a manual drive, or by an

actuator. Links can also be stacked with more parallel links, giving a longer range of motion. This mechanism is used in many machines performing heavy lifting operations.  
(Engineering\_360)

### 3 Method

“System design should be a rational orderly process of analysing a system before it exists, designing it and then evaluating it in prototype or pre-production form.”

These are words from Wilkinson (1974) regarding the design of ship bridge systems, and is quite descriptive for the intension of this thesis. During this process, I have walked across the fields of early-stage product development, mechanisms and mechanical components, and the science of ergonomics. In the hunt for the big idea, I have since the beginning had a mind-set based on Design Thinking and Wayfaring leading towards the future bridge wing workstation.

Ergonomics has largely influenced this project. As discovered previously, ergonomics play a big role for the user's needs concerning the SBW workstation. It has for instance been necessary to map out the ideal working postures to get closer to a better design. The workstation should adapt after the user, and not the other way around. To find out exactly how the workstation should adapt to the user, I have used anthropometric data, and gathered data on peoples' preferred postures through testing with a functional prototype. This has led to new knowledge towards which functions the workstation should have and how it can be designed thereafter. The next step was to provide sensible solutions for the functions that was found relevant. This was done through benchmarking, discovering technology being used in similar products and then combining mechanical principals and compare their characteristics to assess which solutions that can be used. This has been done through research and using my own knowledge about mechanics.

The pre-master's project was influenced by rapid prototyping, where the goal was to build many prototypes and thus have many learning cycles in a relatively short time span. This was necessary because the development was at the very start where the level of ambiguity was high. This master's project started where the pre-master's ended, by continuing to prototype in a higher resolution. The goal has been to provide a proof of concept prototype of the resulting ideas from the pre-master's thesis that can be used for a more thorough test through an experiment involving unbiased participants. This has brought me further to a better understanding of the user's needs and what characterises a good workstation. However, having started from scratch, the development is still in an early phase. The process has been long and ambiguous, which is further discussed in section 11.3.

## 4 Bridge Wing Workstation Preconditions

### 4.1 Definitions

In this thesis, the same definition as in the pre-master's thesis of a ship bridge wing, and the two persons working there, the captain and the first mate, will be used. The definition of these are found in section 4.1 in the pre-master's thesis. The scope of this thesis is further constrained from the SBW as a total, down to the mechanical aspects of the SBW workstation. The workstation will in this thesis be described as followed:

*The workstation of a ship bridge wing consists of the entire construction of equipment and devices from which the bridge personnel can control the vessel. This involves tasks in relation to manoeuvring the vessel, handling on-board equipment such as engines and alarm systems, and communication both on-board, with other vessels and with personnel outside the ship.*

The workstation consists of one or more consoles, including their devices. Consoles and devices are for this thesis defined in the section of abbreviations and definitions on page xvii. These are not general definitions of the norm at sea, but strictly restricted to this thesis, in order to ease the descriptions and discussions in the following chapters.

### 4.2 Constraints

#### 4.2.1 Task Divided Workstation

The scope of this thesis is constrained by the same limitations as the pre-master's thesis concerning the SBW, which can be found in section 4.2 in the pre-master's thesis. A conclusion was made that the workstation should be split in two, with one for each of the two officers working on the SBW, but within reach of both. The captain's workstation contains all devices relevant for manoeuvring the ship, while the first mate's workstation consists of all other devices, typically switches for power and alarms, as well as communication devices. The focus in this thesis has primarily been around the captain's workstation and the devices relevant for manoeuvring the ship.

#### 4.2.2 Type of Ship Bridge Wing

As for the pre-master's thesis, the focus for this thesis has been on bridge wings for mid-sized to large vessels, Mainly ferries and cruise ships with the ship bridge located in front of the ship such as M/S Color Magic, which was visited during the pre-master's project.

For the sake of simplicity, specific limitations regarding the SBW have been set. The bridge wing type that is relevant for this thesis has the following characteristics.

- The SBW has the same shape and approximate size as that of M/S Color Magic, with a floor space of approximately 1.5 – 2.0 m wide, and 2- 3 m long.
- Windows reach from the ceiling to the floor of the SBW
- The ship is equipped with the following propulsion and manoeuvring units
  - Main propellers
  - Rudders
  - Bow thrusters
  - Stern thrusters

## 5 Working positions

In the development of a workstation, it is necessary to identify where the user might need to be placed relative to the environment in order to get the information he needs and be able to perform his tasks in an ergonomic and efficient manner. During the visits described in the pre-master's thesis, it was discovered that the captain was constrained to one position to reach the manoeuvring devices that, in order to get the necessary field of view, led to ergonomically bad postures.



*Figure 15: Straining working positions.*

The workstation shown in figure 1 based on the outcomes of the pre-project, might not provide the best position which, as mentioned in the pre-master's thesis, might be several positions. A key insight from a visit at KM in January 2016 was that the direction that this workstation points, which is straight out of the SBW or sideways relative to the whole ship, is actually a rarely used direction to see during docking and undocking. Most of the time, the relevant visual information is given along the shipside when the captain aligns the ship, which is in the backwards direction or forward if the SBW is located by the aft end of the ship.

### 5.1 Placement of the Workstation

During the pre-master's project, many workstation prototypes were tested with basis on different locations; Workstations based on the floor, along railings on the side of the SBW, hanging from the ceiling and mounted on the user's body. The different placements were contemplated through the different prototypes that were built. The conclusion was that the most promising placements, from a user perspective, were on the floor or suspended from the ceiling. The reasons for giving a high score for ceiling based workstations were mainly about clearing the floor area, thus providing more freedom of space for the SBW personnel.



And, if the console suspension is provided enough joints, the workstation can be adjusted to numerous positions. From a technical perspective, there are a few obvious drawbacks with a workstation suspended from the ceiling:

- In order to accommodate for the weight and size of the console and at the same time have a flexible workstation, the suspension from the ceiling would have to be quite massive, which hardly would look discrete.
- The stress on the suspension from oscillations at sea would be significant, which would be an obstacle upon designing it.
- A workstation mounted in the ceiling, would give less opportunities to provide features for body support, in comparison to a floor based console.

Because of these drawbacks, it was decided to focus the further development on floor based consoles. To maximize the field of view, the bridge officers' freedom of movement and get the best basis for making the workstation adjustable, its placement should be at the centre of the SBW. In terms of how far out on the ship bridge wing that the workstation should be placed, there is a balance point between sufficient field of view for the captain and the freedom of movement in front of the workstation. Regarding the placement of the user in relation to the workstation, there are two key consequences:

- Placing the user in front of the workstation means that the user must reach backwards for the devices.
- Placing the workstation in front of the user means that the console will steal parts of the field of view, forcing the captain to look around it. This assumes that the bridge wing has an open design with windows all the way down to the floor in addition to windows in the floor in order to maximize the field of view.



Figure 16: Left: Devices placed behind the user. Right: Part of view is hidden by console. The red hatched area is a blind zone.

Because of these consequences as well as personal preferences, it is impossible to define a perfect working position. On the contrary, one should as far as possible facilitate for the captain to decide his own working position, which from an ergonomic point of view, should be more than one position to avoid static effort.

## 5.2 Identification of Relevant Positions

### 5.2.1 Knowledge Gained After Visits

After studying ship bridge officers during bridge wing operations, and talking to different stakeholders, new knowledge was gained that sets prerequisites for identifying relevant working positions. During docking and undocking the captain has to align the ship relative to the quay. During this operation, the most relevant visual information is along the shipside and towards the bow if the quay is in front of the ship.

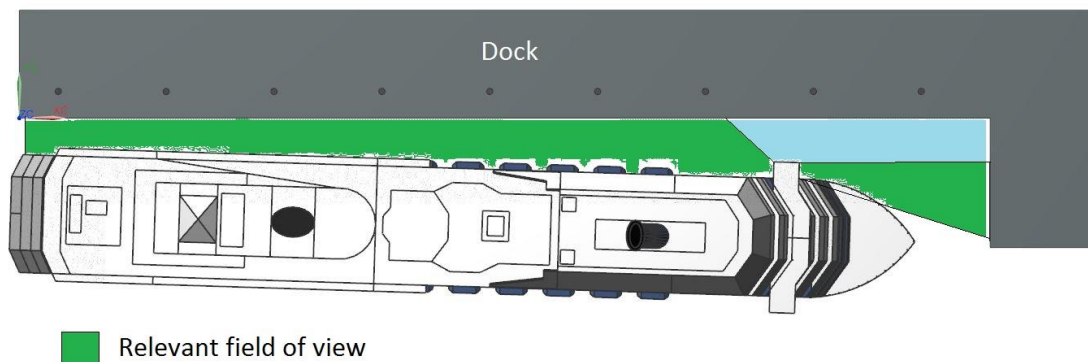

*Figure 17: The most relevant field of view during docking.*

The area marked in green on the figure demands the most of the captain's attention during a docking/undocking operation. This means that the captain most of the time will look out of the rear or front window of the SBW. The most relevant orientation for working positions at the SBW will therefore be facing sideways relative to the SBW, or parallel with the shipside. This does however not mean that the view out of the front window of the SBW, or perpendicular to the shipside, is irrelevant. The ship bridge officers also takes reference points from the surroundings ashore. For example, on the cruise ferry M/S Color Magic, a line is drawn on the window pointing out of the ship, which is used as a reference. When this is aligned with two other lines marked up outside in the harbour in Oslo, the bridge wing officers know that the ship has reached its stopping point. It should also be mentioned that there might be other SBW operations where the view out of the side window is more relevant.

### 5.2.2 Relevant Positions

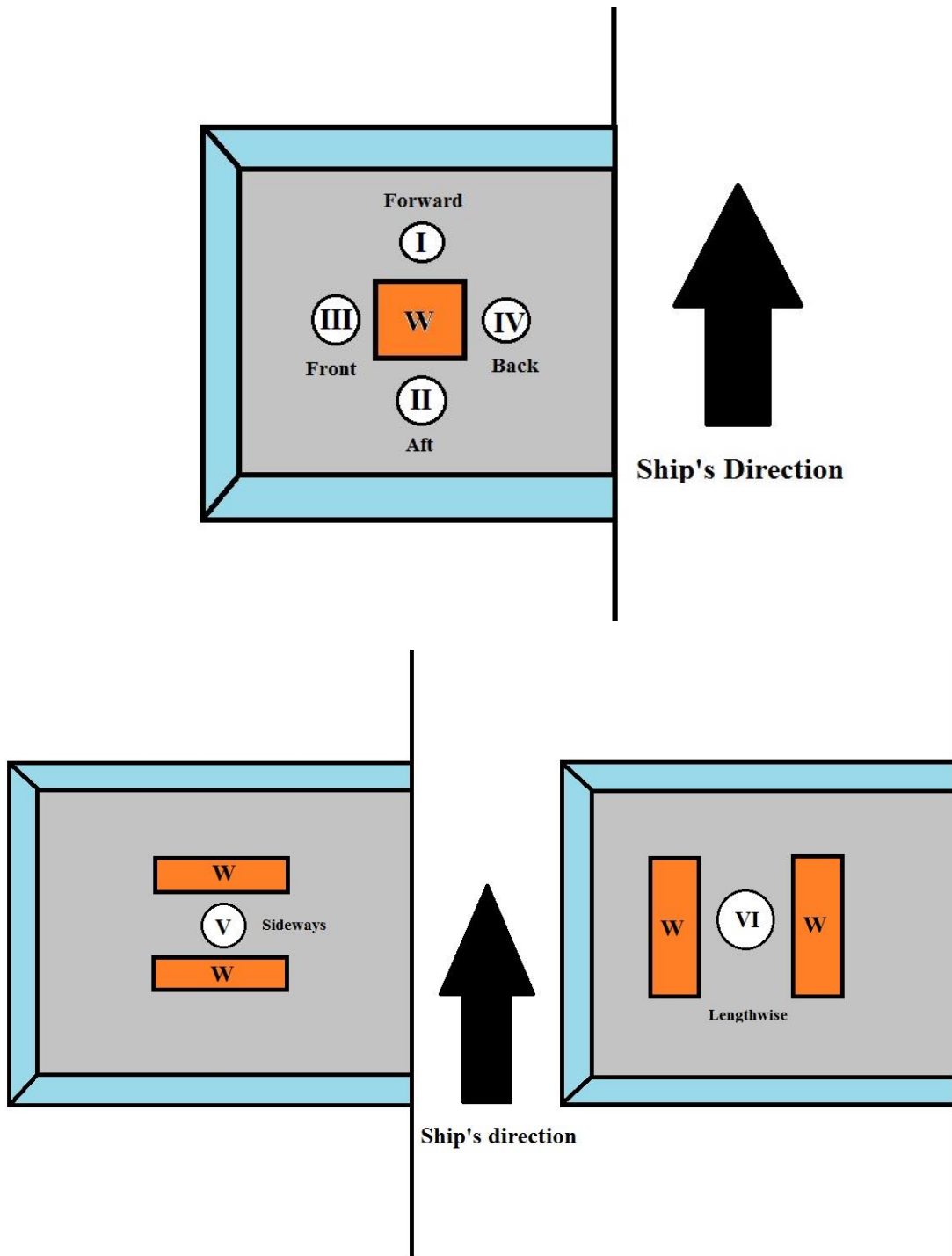

Figure 18: Possible working positions. The ship bridge wing is seen from above.  
W: Workstation

Working positions were initially identified by quickly drawing sketches giving an overview. Figure 18 shows the different possible working that the captain might have in relation to the workstation on the ship bridge wing. The two pictures show the two ways that the user can be placed in relation to the workstation:

1. **Console in the centre**

The user stands between the windows and the console

2. **User in the centre**

The user is surrounded by the console, operating devices on either side.

Putting the user in the centre depends on a workstation split in two consoles such as suggested in the pre-master's thesis. The different positions have different characteristics.

#### *5.2.2.1 Console in the Centre*

In the case where the user stands in the periphery of the SBW with the console in the centre, the accessibility of devices are dependent on the user's orientation. As mentioned, the captain in most cases needs to look backwards in order to align the ship, but the forward view is also important in cases where the vessel docks with the bow against the quay. That means that for these cases, with the captain looking backwards the captain will have the devices in front of him if he is standing in position I as depicted in figure 18. He will then be affected by the restrictions that the console put on the field of view. If the user stands in Position II, the opposite happens; The most relevant view is free of obstacles but the devices are behind the user. In the positions III and IV, the orientation of the devices are perpendicular to the most important view relative to the captain, which means that it gets easier for the captain to switch his viewing to either forward or backwards side. On the contrary, using the Position III means that the captain must turn his back to the devices when he occasionally needs to look out the window pointing out to the side. An example of this is shown in the left picture of figure 15. If he uses Position IV in this case, some of the field of view will be taken by the console.

#### *5.2.2.2 User in the Centre*

If the user stands in the centre, he will have the devices available at his side both with a lengthwise and sideways orientation of the console halves. In Position VI the captain must turn 180 degrees if the need for looking in the opposite direction occurs. With a sideways orientation such as Position V, the user only needs to turn his head in order to look in the

other direction, although looking forwards or aft for a longer period might be stressful on the neck. Position V would also likely be covering the field of view for any floor window on the sides.

### 5.2.2.3 Position Evaluation

#### Looking aft

Workstation setup	Position	Position no.	Access to devices	Field of view
Console in centre	Forward	I	In front	Partially blocked
	Aft	II	Behind	Clear
	Front	III	Side	Clear
	Back	IV	Side	Poor
User in centre	Sideways	V	In front & behind	Partially blocked
	Lengthwise	VI	Sides	Clear

#### Looking forward

Workstation setup	Position	Position no.	Access to devices	Field of view
Console in centre	Forward	I	Behind	Clear
	Aft	II	In front	Partially blocked
	Front	III	Side	Clear
	Back	IV	Side	Poor
User in centre	Sideways	V	In front & behind	Partially blocked
	Lengthwise	VI	Sides	Clear

#### Looking sideways

Workstation setup	Position	Position no.	Access to devices	Field of view
Console in centre	Forward	I	Side	Clear
	Aft	II	Side	Clear
	Front	III	Behind	Clear
	Back	IV	In front	Partially blocked
User in centre	Sideways	V	Sides	Clear
	Lengthwise	VI	In front & behind	Partially blocked

Good
Neutral
Bad

Table 1: Evaluation of different positions looking in different directions.

The tables above are an evaluation over each of the identified working positions and how they affect the accessibility to the devices and the field of view when the captain has his attention in a certain direction. By “Partially blocked” means that the console or parts of

the console, depending on the workstation setup, will be placed in front of the captain and thereby potentially blocking necessary view. This is not considered particularly bad since the captain relatively easy would be able to look around it depending on its design and size. For Position IV, the field of view will be poor in the case of looking forwards or backwards because the view angle to the shipside will be very small compared to standing in front of the console as in Position I. As can be seen, there are none of the working positions that are problem free in all cases.

### 5.3 Further Evaluation of Working Positions



*Figure 19: Beta-prototype of functional prototype for testing working positions.*

To get a better picture of which working positions that matters the most upon the design of the workstation, the practical consequences of each working position are not the only factors. The user's personal preferences also plays a big role. Captains, like other human beings, have different habits and have different opinions on what are the most comfortable positions and which gives the best overview. An experiment was conducted to map the differences in personal preferences among different working positions. This experiment and its results are described in chapter 9.

## 6 Console

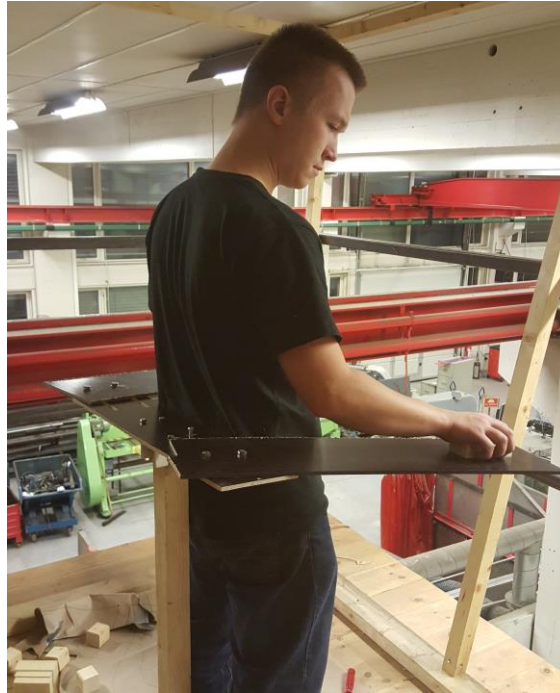

*Figure 20: Testing of console during the pre-master's project*

The many iterations of prototyping and testing during the pre-master's project lead to the conclusion that a split console emerging from the floor behind the users back, stretching around the user with devices on either side seemed like a comfortable and sensible design. After some more contemplation, it was realized that having such a U-shape makes it a lot more inconvenient to get in and out of position on the workstation, since the user has to move around the console every time. That was when idea of splitting the console in two separate parts that the user can stand between emerged. This makes it easy to get in and out of position, as well as providing the opportunity to lean both arms on the console parts. A back support can also be fit in such a way that it does not feel interfering. This configuration is further assessed in chapter 8 and 9

### 6.1 Reduction of Size

As mentioned in the pre-master's thesis, there is a great potential in reducing the size of the SBW console, if all other devices than those directly related to the manoeuvring of the ship is placed on a separate panel. The only devices left in such a case would be those of the propellers, rudders and thrusters. The console should, however be large enough to be able to feature ways of giving the captain body support. From an ergonomic point of view, there

is a balance point between having enough freedom of space on the floor of the SBW and having “enough console” to lean on.

## 6.2 Placing Devices

Devices on bridge consoles are often numerous and of different types: Power switches, alarm switches, control devices, communication, etc. (Wilkinson, 1974) states the importance of placing devices in logical groups associated with their equipment. In this thesis’s case of splitting the workstation between the captain’s and the first mate’s work tasks, the control devices associated with the captain’s workstation, all remain within the same group of manoeuvring the ship. This will remove the challenges of today’s scattered SBW workstations, which in certain situations of many devices giving feedback at the same time might lead to cognitive overload. The focus can then be turned on ergonomics and avoiding static efforts. (Das & Sengupta, 1996) and (Grandjean, 2005) showed how a console panel layout could look like based on anthropometric data (see figure 7 in section 2.2.1). A similar diagram was drawn in order to try different placements.

The figure shows anthropometric measurements of the author. The hatched area marks the placement of the lower arms when rested on the table standing upright. The black arcs where drawn with the purest possible arm movement, holding the torso steady at the same position. The small arc represents the grasping distance when the elbow is rested on the table, and the larger arc shows the grasping distance when the arm is stretched out. As can be seen, this data is not accurate in any way, but the distances do lie within the range recommended by (Grandjean, 2005)

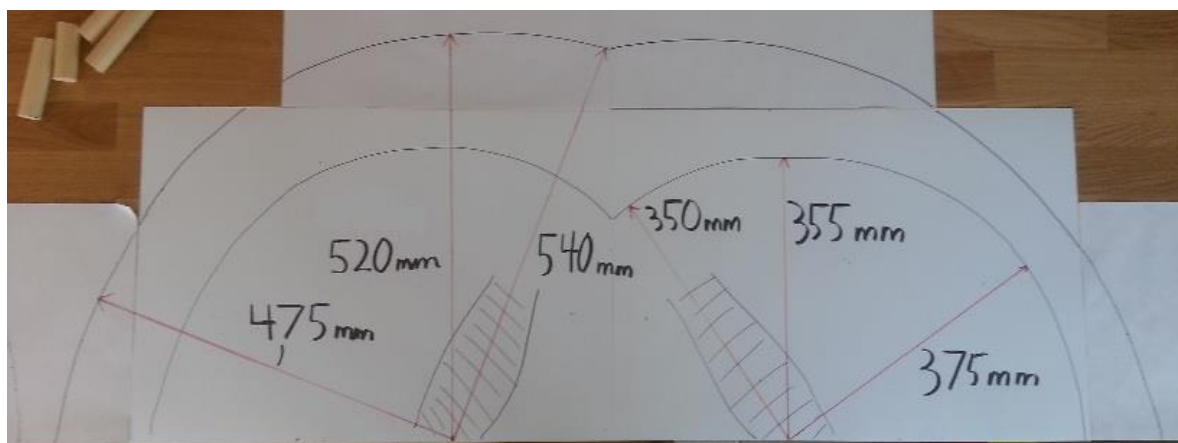

Figure 21: Author's measured standing grasping distances.





Figure 22: Maximum grasping distances.

The maximum reaching distances were then tested with mock-up devices considering the working positions identified in chapter 5. The upper left picture symbolises having the console in front, and the upper right shows the maximum reaching distance when the console is on one or both sides of the user. The maximum grasping distance to the sides were definitively the least comfortable. Stretching the arms out to the side will lead to discomfort and fatigue in relatively short time. A quick test was performed by holding the arm stretched out on the table in an upright position and register the time it takes before discomfort occurs. When the arm was stretched out in front, as seen in the upper right picture, the need for changing position occurred at approximately five minutes. With the arm stretched out to the side, it took half the time before the same need occurred. The positions were not problematic for a shorter period. This indicates that devices that are frequently used, should not be placed far out to the side in relation to the user. In general,

frequently used devices should be placed within the inner sweep arc shown in figure 21, which provides the possibility of leaning the elbows.

## 6.3 Technical Requirements

### 6.3.1 Loads

When designing a workstation it is important to consider the relevant load conditions in the workstations environment. The classification companies put strict demands on for instance maximum strength against force impulses in rough sea as well as vibrations (DNV-GL, 2015). The regulations are not considered in this thesis, but the fact that the consoles must be robust for various conditions is worth while considering at this stage in the development when the development phase is more typified by convergent thinking (Gerstenberg, et.al 2015)

### 6.3.2 Health and Safety

Regarding health safety, the following cases are important in relation to the SBW workstation and its consoles.

- Stumbling hazards
- Cutting and hooking hazards
- Crush hazards
- Pain and musculoskeletal troubles related to static effort.

Stumbling hazards can relate to height differences on the floor of the workstation, and floor based equipment of low height that one might leave unnoticed and thereby stumble over. Cutting and hooking accidents can relate to sharp surface edges and corners that one might hook ones clothes on or get cut. If the console is made up of more than one part that can move in relation to each other, there is always a chance that one might get pinched or get parts of the body crushed between parts of the workstation. The last case is related to the ergonomic effects of being constrained to different postures.

The first two hazards have in common that if they are present, they both have a high probability of occurring, especially concerning the conditions at sea. During rough sea, when the workstation is not at ease, the probability of stumbling cutting and hooking oneself will increase. However, these hazards have in common that they have relatively low consequences. Stumbling, cutting and hooking oneself, will probably not lead to

serious damage to the body, but more likely minor injuries such as small wounds or bruises. In the event of hooking ones clothes on an edge, it might cause damage to the clothes but might also be a cause for stumbling. Crushing accidents between console parts while adjusting the workstation is also a likely event if the console parts are not secured properly. The consequences depend on which body part is crushed and the force exerted, which is dependent on the mass and velocity of the crushing parts upon impact. The consequences will in most cases not be serious damage.

Neither of the hazards mentioned above are serious threats, but should nevertheless be prevented as much as possible in a workstation design. Stumbling hazards can be avoided by recessing any floor based mechanisms or equipment into the floor, or raising the surrounding floor. Any edges should be blunt to remove cutting hazards. Hooking hazards can also easily be removed by interleaving any parts that point out, such as hand rails.

The cases related to ergonomics can be hazardous to the health. From the visit on-board M/S Color Magic during the pre-project, the captain answered that a normal docking operation in the port of Oslo or Kiel, takes about 15 minutes. Standing in one place for long periods is wearisome and painful, and it also causes increased hydrostatic blood pressure in the legs, which can lead to dilation of the veins in the legs, swelling of tissue and ulceration of the oedematous skin.(Grandjean, 2005) This can be prevented by providing solutions for changing ones working position which is widely discussed in this thesis.

## 7 Workstation Adjustments

Ergonomic matters such as static postures and boredom, as well as personal differences, speak for a workstation that allows variation. This chapter concerns different adjustments, and ways to implement them.

### 7.1 Benchmarking

The search for different solutions for adjustments began with benchmarking. A trip to IKEA was made to learn from adjustment solutions on furniture.



Figure 23: Benchmarking at IKEA

The following findings were made from the trip to IKEA

- Furniture that can be expanded, or in other words consist of parts that can be pulled out to make it larger, such as sofa beds use four-bar links to pivot the extra furniture part out. This could be useful for expanding a console to reach, for instance, further out on the SBW
- There are both electrically powered and manually operated tables. They both use leadscrews to increase/reduce height.

There has also been other discoveries along the way:



*Figure 24: Alternative height regulation and archive shelves*

The left picture shows the height adjustment mechanism of a table. It consists of pneumatic springs in combination of a steel wire running through pulleys. The wire is at one end connected to a bracket, which has a moment arm down to the piston rod of the gas spring. The wire then runs through a series of pulleys through both table legs, and connects at the other end to the underside of the table surface. The length of the moment arm can be reduced or increased by a manual crank on a screw, and this regulates the force that the gas springs can pull on the wire. This further on makes it possible to adjust the table for different loads. One can in other words decide how heavy it should be to lift the table. The height adjustment locks by a simple pin through a hole inside one of the table legs, which can be released simply by pulling the lever placed under the edge of the table.

The picture to the right shows archive shelves that can move sideways by a manual crank connected to wheels through a chain or belt drive. This could be a simple solution for merging or splitting console parts.

## 7.2 Desired Adjustments

We know that captains come in different heights and that some SBW workstations are being used by more than one bridge wing officer. It is unfortunate for the captain if he must bend his torso in order to control the devices. He will then be making static muscle effort, which as explained in section 2.2 can be uncomfortable and lead to musculoskeletal troubles in the long run. Because of this, it is clear that a height regulation is needed.

In terms of the working positions evaluated in chapter 5, it might be reasonable to provide a solution for providing a change between “split” and “merged” configuration of the workstation as well as being able to turn it to change orientation. As stated by (Vezina et al., 1992), it is important before settling for a workstation design to examine details of the task of the workstation, or in this case the details of SBW operations. The need for adjusting width and orientation was therefore further examined through prototyping and testing, as described in chapter 8 and 9.

## 7.3 Mechanisms

This section looks at adjustment solutions through the use of the mechanical principles described in section 2.3. This section assesses each mechanism’s suitability for each adjustment function.

### 7.3.1 Height Adjustment

As for performing lifting tasks of medium sized objects with weight less than 100 kg, pneumatic springs are excellent as a one-way actuator, and can be put in combination with various mechanical transmissions as shown in the following table.

<i>Solution</i>	<i>Advantages</i>	<i>Disadvantages</i>
<i>Wire &amp; pulley in combination with gas spring</i>	<ul style="list-style-type: none"> <li>• Cheap</li> <li>• Easily implementable</li> <li>• Can together with gas spring provide weight regulation</li> <li>• Allows easy and fast adjustment</li> <li>• Consumes little space</li> </ul>	<ul style="list-style-type: none"> <li>• Fatigue on wire</li> <li>• Imprecise</li> <li>• Strength restricted by wire</li> </ul>
<i>Rack and pinion and gas spring</i>	<ul style="list-style-type: none"> <li>• Allows quick adjustment</li> </ul>	<ul style="list-style-type: none"> <li>• Wear on pinion gear</li> <li>• Rotational input</li> </ul>
<i>Chain drive and gas spring</i>	<ul style="list-style-type: none"> <li>• Allows quick adjustment</li> </ul>	<ul style="list-style-type: none"> <li>• Rotational input</li> </ul>
<i>Screw drives</i>	<ul style="list-style-type: none"> <li>• Precise adjustment</li> <li>• Handles heavy loads</li> <li>• Self-locking</li> <li>• Requires little space</li> </ul>	<ul style="list-style-type: none"> <li>• Slow adjusting due low gear ratio</li> <li>• Hard to implement without rotational actuator</li> </ul>
<i>Scissor lift and screw drive</i>	<ul style="list-style-type: none"> <li>• Handles heavy loads</li> <li>• Self locking</li> </ul>	<ul style="list-style-type: none"> <li>• Slow adjusting</li> <li>• Requires rotational input</li> </ul>
<i>Scissor lift and gas spring</i>	<ul style="list-style-type: none"> <li>• Quick and easy adjustment</li> </ul>	<ul style="list-style-type: none"> <li>• Imprecise</li> </ul>
<i>Gas spring</i>	<ul style="list-style-type: none"> <li>• Quick and easy adjustment</li> <li>• Requires little space</li> <li>• Few parts</li> </ul>	<ul style="list-style-type: none"> <li>• Imprecise</li> <li>• Will alone be “bouncy” due to the compression of air inside.</li> </ul>

Table 2: Advantages and disadvantages with solutions for height adjustment

### 7.3.2 Width Adjustment



*Figure 25: Sliding mechanism for car seat.*

To solve linear motion for the console parts manually, they can simply be placed on linear guides provided with a locking mechanism, which for instance could be a pin engaging into slots along the guide such as with the traditional mechanism that moves car seats back and forth. Width adjustment could also be solved with a rotational actuator, in which case the solutions in the following table are applicable.



<i>Solution</i>	<i>Advantages</i>	<i>Disadvantages</i>
<i>Belt drive</i>	<ul style="list-style-type: none"> <li>• Easy implementation</li> <li>• Requires little space under the floor</li> <li>• Silent</li> </ul>	<ul style="list-style-type: none"> <li>• Prone to wear</li> <li>• Would probably require gear reduction</li> </ul>
<i>Chain drive</i>	<ul style="list-style-type: none"> <li>• Power transmits through intermitting surfaces</li> </ul>	<ul style="list-style-type: none"> <li>• Noisy</li> <li>• Would probably require gear reduction</li> <li>• Prone to jam</li> <li>• Leads to excessive play in movement upon wear</li> </ul>
<i>Rack &amp; Pinion</i>	<ul style="list-style-type: none"> <li>• Power transmits through intermitting surfaces</li> <li>• Few moving parts</li> </ul>	<ul style="list-style-type: none"> <li>• Requires much space in floor and under console parts.</li> <li>• Prone to jam</li> <li>• Would probably require gear reduction</li> <li>• Leads to excessive play in movement upon wear</li> </ul>
<i>Screw drive</i>	<ul style="list-style-type: none"> <li>• Precise adjustment</li> <li>• Very durable</li> <li>• No excessive play</li> <li>• Few moving parts</li> <li>• Power transmits through intermitting surfaces.</li> </ul>	<ul style="list-style-type: none"> <li>• Moment of inertia in lead screw restricts acceleration</li> </ul>

Table 3: Advantages and disadvantages with solutions for width adjustment

### 7.3.3 Orientation Adjustment



Figure 26: Railway turntable. <http://www.ajmrailways.com/model-railways/OO-Track.html>

solving an orientational adjustment mechanism for the workstation is fairly simple. The entire workstation featuring the other adjustments can be placed upon a turntable, similar to those found on particular railways. The rotation itself can be solved with a centred axle through a radial bearing, and some form of axial bearing to take the vertical load. Locking mechanism can, as for the other adjustments be based on a pin through slot.

## 7.4 Evaluation

The request from KM upon assigning this thesis was to find adjustment solutions that are simple in the sense of few parts, easy maintenance and low cost, but at the same time provide a simple and user friendly way of operating them. In all the adjustment cases, one can implement actuators to give powered adjustment functions, but this is likely to be superfluous since the size of the console is likely to be manageable to move by hand. Adjusting the workstation manually is also likely to be quicker than by using powered actuators.

To solve the height regulation, the author will recommend the solution involving wire and pulleys in combination with pneumatic spring, such as shown in figure 24. This solution requires little space inside the console housing. The only part that requires any space of significance is the pneumatic spring, which can be fitted in many ways. The ability to adjust for weight is also a practical feature, although this is probably not much needed in the case of a SBW console. The weight of objects that will be placed on top will probably be insignificant compared to the console. Another thing that makes this a good solution is the

easy way of operating it: one simply clamps a lever and steers the console up and down. The fact that it is a somewhat imprecise way of adjusting the table will hardly be a problem. The console can be re-adjusted easily, and the captain will also get a feel of what is the best suitable height.

For splitting or merging the console, simple linear guides with end stoppers and locking mechanisms will do the trick. This allows for a simple manual push. One can however argue that in rough sea condition when the floor is unsteady, it might be hard, or even dangerous to adjust the width by simply pushing, but such conditions can hardly be the time for adjustment operations. A problem with width adjustment is that the linear guides will have to be implemented in the floor, which might cause a stumbling hazard. However, such guides can be completely interleaved in the floor which removes this problem.

For the orientation adjustment, whether a turntable can be embedded into the floor of the SBW depends on how much free space is underneath. It might be necessary to elevate the entire floor with a clearly marked edge to reduce the risk of stumbling to get an integrated turntable.

## 8 Functional Prototype

### 8.1 Desired Features

To test the desired features of a workstation, it was decided to build a functional prototype. As stated by Das and Sengupta (1996):

“ An evaluation of a mock-up workstation design by employing live subjects will enhance operator-workstation fit.”

Prior to the prototype construction, some requirements were made. Along with the adjustment possibilities presented in chapter 7, support features for hands and other body parts was also fitted for testing and evaluation.

### 8.2 Small Scale Beta-Prototype

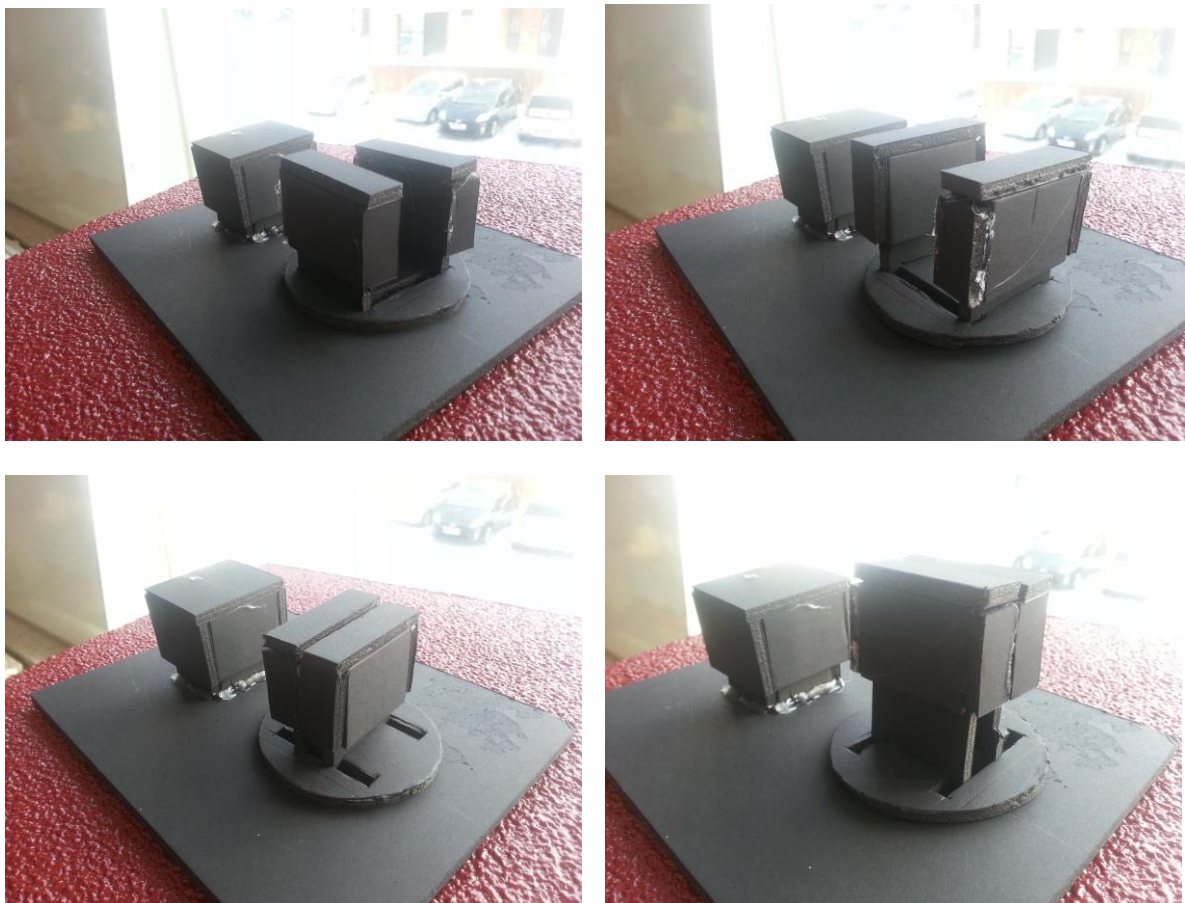

*Figure 27: Small scale prototype showing orientation, width and height adjustment*

A beta-prototype was initially made to visualize the different features that the functional prototype should have for relevant testing. The figures show a mock-up of the SBW floor

with the two workstations for the two crewmembers on the SBW; the first mate's workstation in the background and the captain's split workstation in the front. As the figures indicate, the most interesting features to test would be rotation, or change of orientation, relative positions of the workstation parts and height regulation. The prototype was quickly made with foamboard and glue. This beta prototype gave a good inspiration to how the functional prototype could be built. It was decided to constrain the testing to only include the captain's workstation in the functional prototype. The first mate's workstation was ignored considering the space of the test area, which is the mock-up SBW built during the pre-master's project and for simplifying the test.

## 8.3 Full-Size Functional Prototype

### 8.3.1 The Prototype and its Features

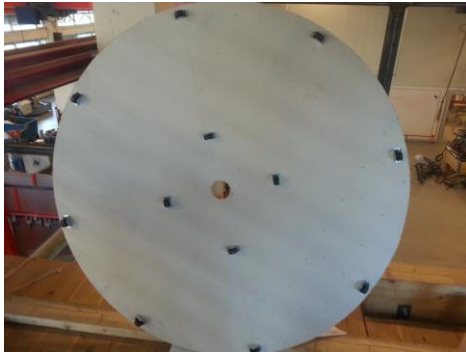

Figure 28: The functional prototype

The decision eventually fell on pneumatic springs for height regulation after assessing several mechanical solutions for adjustment during the benchmarking phase. The simplicity of usage and implementation in the functional prototype led to this decision. Two gas springs were simply taken from office chairs available and installed in the prototype. The two halves of the workstation each consist of two plywood boxes that fit on top of each other. The gas cylinders are fitted inside, supporting and providing elevation of the upper part of the workstation console. It is operated by pulling a lever sticking out of the side of the console. The medium height of the workstation was based on the average of the values for standing elbow height for western men and women, described in section 2.2.1. the actual interval between minimum and maximum height on the console was 950 – 1100 mm. The workstation is placed upon a large turntable to provide different orientations on the SBW. There are tracks on the turntable on which the two console halves are given a linear degree of freedom. They can be locked together for a traditional centre based workstation or locked apart such that the captain can stand in the middle. The devices are placed on the top surface of one of the console halves and can be rotated to counter the rotation of the workstation in order to eliminate confusion about their orientation. Support rails were also added around the top of the workstation prototype for body support.

### 8.3.2 Insights from Initial Subjective Testing

After having completed the prototype, some insights came to mind. Having tested several low resolution workstation prototypes during the pre-master's project, it appeared to be some noticeable similarities between the latest prototype and a traditional SBW console. It's a square shaped box based at the centre of the floor at the SBW. However, the main problems with the traditional SBW workstations such as the lack of adjustments after the user and tight work space around the console had been addressed. The workstation is now suitable for captains of different heights through the height regulation and the captain can choose to have a low configuration of the workstation or raise it to get elbow support. The captain can also choose to have a merged configuration of the workstation and stand around it like traditional SBW workstations, or have a split configuration and stand in the middle. The size of the console is also significantly reduced compared to many SBW workstations, such that the space around the workstation is bigger, allowing for higher freedom of movement. All of the devices that are irrelevant for the actual manoeuvring of the ship are separated from the captain's workstation making the device panel much more tidy.

A weakness of the prototype is the user interface for adjusting the console. The lever that actuates the height regulation mechanism is located quite low on the side of the console. This was however constrained by the resources available at the time the prototype was built. The pneumatic cylinders that were used were also dimensioned to support heavier loads, thus making it heavy to lower the consoles. This was compensated for by putting heavy steel billets as weights inside the compartments of the console parts. The weights were still not quite heavy enough to make the operation of lowering the consoles light. The static friction between the lower and upper part of the console is also quite high, thus making the parts liable to jam easily. This means that the user must assist the gas cylinders with force when regulating the height.

Another limitation is the width adjustment. The locking mechanism, which consists of simple wooden blocks that act as wheel stoppers, only provide locking when the console halves are fully merged or fully split. In retrospect, other positions between the console parts are likely to be redundant. The sliding motion of the console parts are also not completely smooth. The wheels of the consoles have a tendency to derail from the tracks that keeps the motion linear. The wheel stoppers, also often interfere with the adjustment, often caused by unintentionally kicking them into locking position. Another weakness is that the turntable on which the workstation is placed is not embedded into the SBW floor. This leaves a height difference in the floor which compromises the freedom of movement on the SBW. This height would also represent a safety hazard by increased probability of stumbling. There is also a chance that one might hook ones clothes on the handrails fitted. It would make more sense to interleave these into the console sides.

These are all weaknesses that compromises the advantages that the adjustments of the workstation is meant to have, but the problems are all relatively easy to work around in a potential new prototype that would have been built if time allowed it. A final product would have been designed much more in detail with more refined mechanical solutions. The purpose of this workstation has been to evaluate the adjustments and working positions. Issues such as HSE at real SBW workstation have not been taken into account for this prototype.



## 9 Experiment

The beginning of the pre-master's project was influenced by probing (Gerstenberg et al., 2015) where knowledge was gained through iterations of prototyping. After a while, the focus was increasingly targeted towards a specific concept of floor based split-consoles where much time was spent improving this design through prototype iterations. During this, the authors might have become less willing to try other concepts, that might be more promising, also known as The Sunk Cost Effect described by (Viswanathan & Linsey, 2013). In order to give a proof of concept of the functional prototype described in chapter 8, an experimental study with unbiased test subjects needed to be conducted. The intentions of the following experiment has been to map how useful the different functions of the prototype are, and which working positions that the test subjects prefer. The workstation setups chosen by the test subjects could be useful to the further concept development of the SBW workstation.

### 9.1 Test Scenario

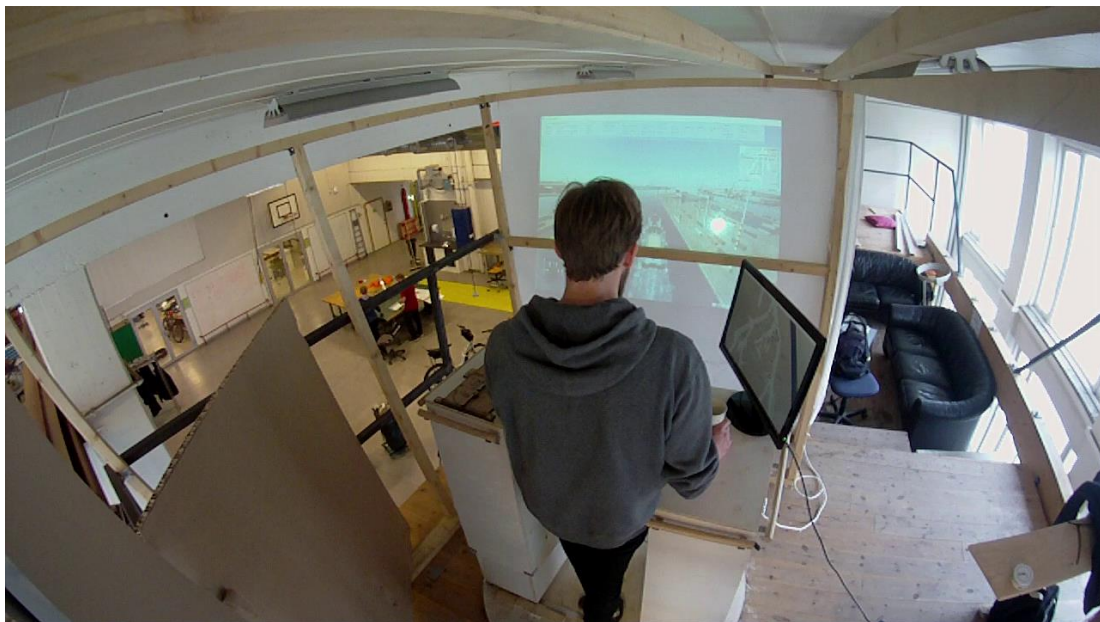

Figure 29: Test subject during experiment.

A test scenario was created to test the different features of the workstation prototype. A ship simulator software *Ship Simulator 2008* was used for this scenario. The console devices were connected to the simulator software through an *Arduino* microcontroller attached inside a compartment under the top of the console made available through a top

lid. The simulator software was projected onto a white sheet attached to the side of the SBW mock-up and a test scenario involving the use of all the devices placed on the workstation; propeller, rudder and thrusters for the bow and stern, was created. An ECDIS was displayed on a screen placed on the vacant console half, showing waypoints that indicated the route of the mission. The scenario was set in the port of Hamburg and consisted of two parts: The first part was relatively easy manoeuvring through a section of the port where only the propellers and rudder are necessary in use. In the last part, the subjects entered a dock, turned the ship 180 degrees and docked alongside the quay by using the thrusters. This made it possible to see whether participants would choose different positions for different manoeuvring situations.

## 9.2 Experiment, Part I

Test subjects were invited up to the mock-up SBW, now turned into a SBW simulator to act as a captain for a while. Each subject was introduced to the workstation initially without explanation in order to get a first impression of the prototype. They were then encouraged to discover the adjustment possibilities for themselves and set up the workstation in their own preferred way and were then assigned to the docking mission. After the mission, each of the participants was asked to evaluate the different adjustment features of the prototype through a questionnaire (see appendix A), both how easy they were to understand and how easy they were to use. The participants were also shown the main working positions relative to the workstation presented in chapter 5, and asked how likely they were to use each of the positions.

### 9.2.1 Participants

Participants were collected from the Department of Engineering Design and Materials at NTNU. Ten people were signed as test subjects during this experiment. Both students of different study progress and PhD-candidates were signed as participants. The participants were all male, as female participants are harder to get a hold of at the department. The participants' ages ranged from the early twenties to the early thirties. The time that each participant spent to complete the test scenario varied between 10.5 to 17 minutes.

## 9.2.2 Adjustment Features

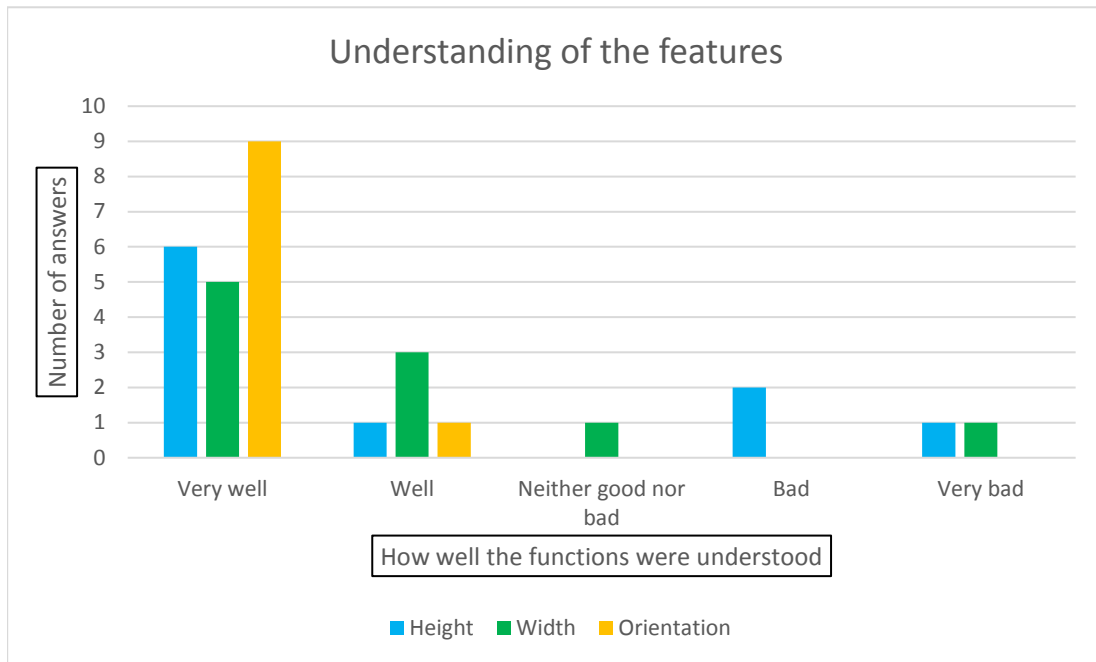

Figure 30: How well the functions were understood.

Most of the test subjects were quick to understand the functioning of the adjustments available. Some participants were rather reluctant to explore the workstation in the beginning, but most of them quickly understood how the different functions worked once they were told about them. The figure indicates that all of the functions were easily understood and especially turning the consoles in different orientations. The adjustment functions for height and width were however not as intuitive for some.

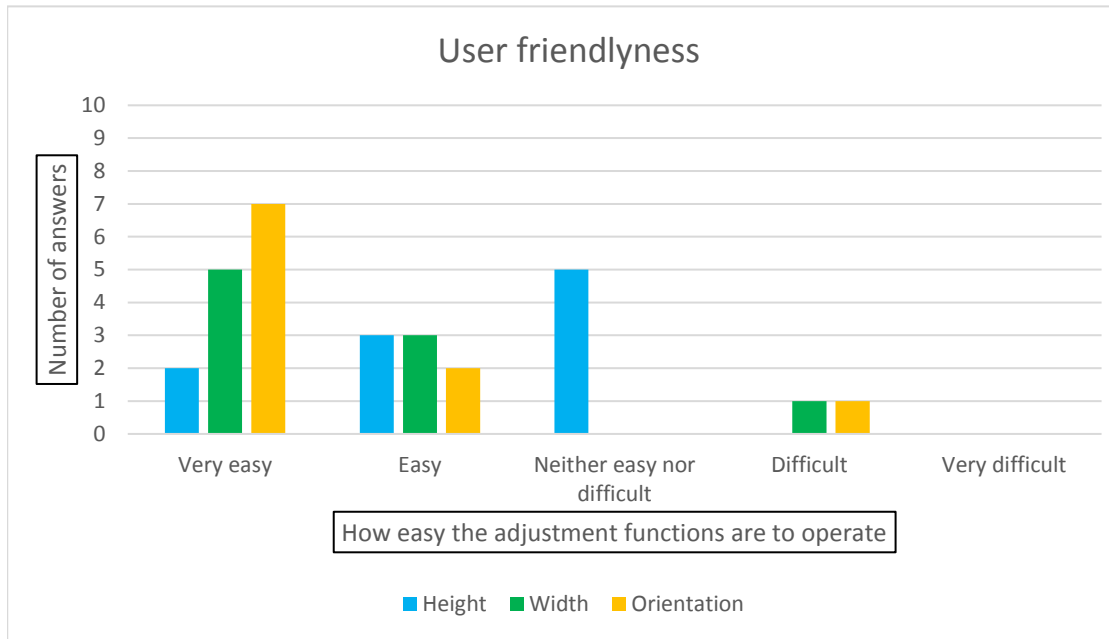

Figure 31: How difficult the adjustments were to operate.

Like the initial understanding of the workstation, the functions were also generally perceived as easy to use. Half of the participants answered that the height regulation is neither easy nor difficult to operate, clearly indicating that there is room for improvement. This coheres with the problems with friction between the lower and upper console parts, described in section 8.3.2.

### 9.2.3 Working Position

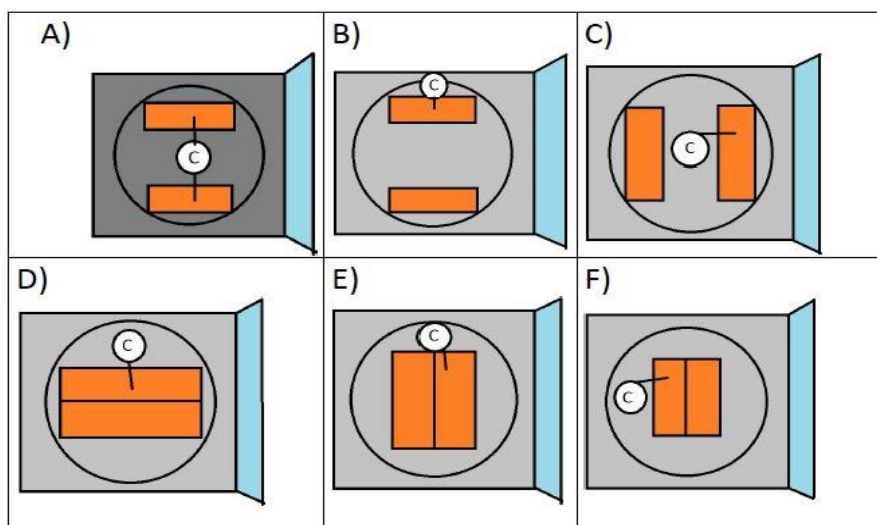

Figure 32: Sheet given to the participants for evaluation of the positions.

Figure 32 shows the working positions relevant for this experiment setup. The positions take base in those identified in chapter 5. The blue field shows the bridge wing side where the simulator was projected. This was the only side of the mock-up SBW that demanded the participants' attention. The C-marked circle symbolizes the captain's, or in this case, the test subject's position and where his arms would reach to operate the devices on the consoles marked in orange. The letters A to F represents the different working positions

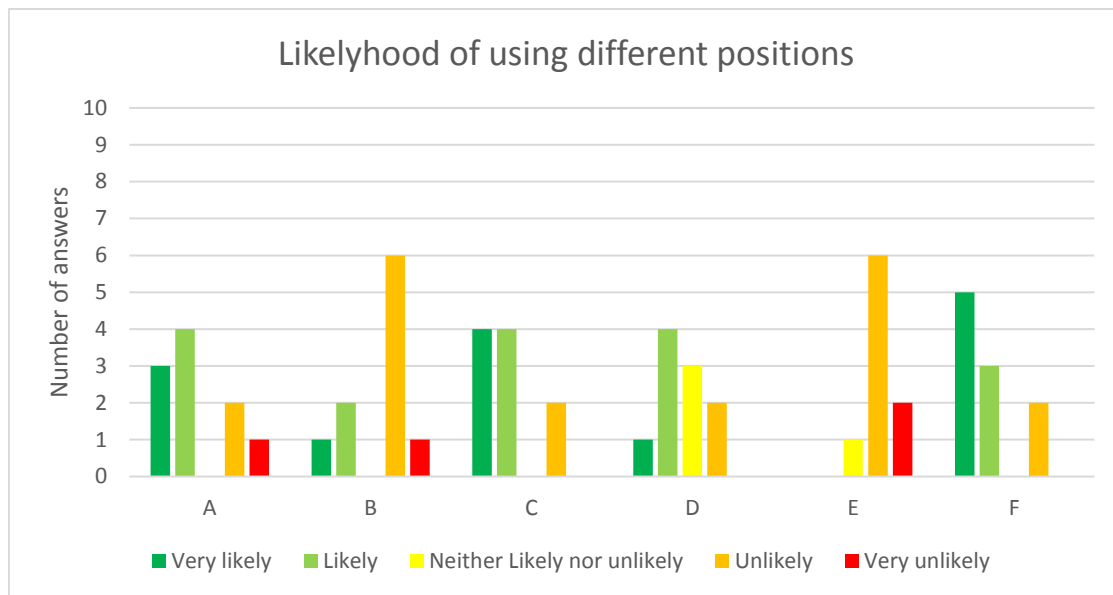

Figure 33: opinions of each position.

The results from the experiment indicate that there are more than one preferred position. Position C and F stand out as likely favourites, while Position A and D seem to be of mixed opinions. Position B and E are quite unattractive though some find it likely to use position B. All in all, the first experiment indicate that the preferred positions on a SBW workstation is a split configuration, standing in the middle with the short console sides facing the attention demanding side of the SBW, or a merged configuration standing behind the consoles with the long side facing the side of attention.

After comparing the answers on the working positions, each position was given a score in strength by giving each alternative a number value. Table 4 shows each of the question alternatives linked to the working positions, taking discrete increments from -2 being the value of "Very unlikely" to 2 representing "Very likely". The alternative "Neither likely

nor unlikely” was chosen as the datum zero making positions with a score below zero, positions not preferred or positions unlikely to be used and vice versa for positions with a positive score. The score of each position,  $S$ , was calculated by multiplying the value of the alternatives,  $A$  with the number of answers,  $n$ , and summing up for all the values for each position. The equation that was used can be written as this:

Likelihood of using position	Value
Very unlikely	-2
Unlikely	-1
Neither likely nor unlikely	0
Likely	1
Very likely	2

Table 4: Position values

$$S_i = \sum_{i=1}^5 A_i n_i$$

After giving each position a score, the following diagram was made: The diagram shows the positions with a positive value marked in green, and those with a negative value marked in red. It indicates that F is the favourite position, while E is the least preferred.

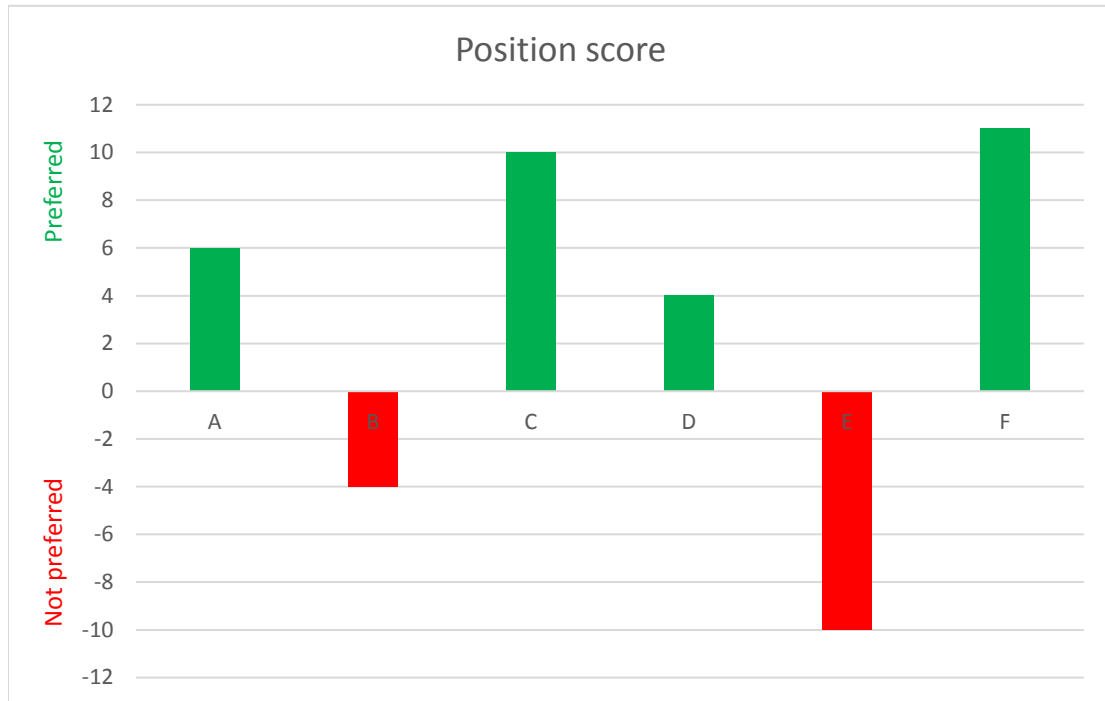

Figure 34: Position score, Experiment Part I

## 9.2.4 General Insights



*Figure 35: Participants trying adjustments and positions during Experiment; Part I*



Some key points were noted after each test subject had carried out the experiment. During the initial part of the experiment, where the participants were encouraged to explore the workstations for themselves, some participants did not discover the height and width adjustment. Some failed to see the height adjustment lever on the console side, and the fact that the height adjustment needed some manual assistance was also not quite intuitive. Adjusting the width was left untried by some in the beginning because they did not realize that the locking blocks were engaged. It was also made clear after having run the experiment with some participants that position E is not worth considering because it is obviously impractical due to the user having to stretch to reach all devices. This is also unfortunate from an ergonomic point of view. Position D is practically the same position, only without the impractical placement of devices.

#### *9.2.4.1 Initial Workstation Setup*

Most of the participants were reluctant to try different setups in the beginning of the experiment. Some did not realize all the working positions until they got them presented for the questionnaire. The initial setup of the workstation when each participant started may have caused a significant bias regarding the participant's choice of workstation setup.

#### *9.2.4.2 Placement of Devices and ECDIS Screen*

The console half of which the devices were placed may have been a limiting factor in the choice of working position, as shifting orientation of the workstation and adjusting the width requires attention to the wire from the microcontroller sticking out of the console half and running behind the projected screen. The console side of which the wire ran from made it strenuous to rotate the console. Also, since the ECDIS was placed on top of the console half without other devices, the setup of the workstation would also affect the visibility of both the projected screen and the ECDIS. With the ECDIS placed on top of the workstation, positions C and F will become impractical. C because the ECDIS must stand right behind the user, and F because the ECDIS will cover a part of the projected screen unless the workstation is rotated slightly to one side, which was a solution some participants chose, as shown in figure 35.

#### *9.2.4.3 Changed Position*

Some participants changed their position during the mission, typically before docking, switching from mainly using rudder and propellers to using the thrusters.

#### 9.2.4.4 *General Opinions*

The following likes and dislikes were noted during the first part of the experiment.

##### **Likes**

- The general ability to adjust the workstation setup
- Hand rails for support
- Height regulation contributing to body support

##### **Dislikes**

- No form for seating: would like to ease burden off legs.
- The placement of the ECDIS as described in chapter 9.2.4.2. There was also a comment given that the ECDIS screen was tiring to watch at such close range.
- The direction output of the thruster controllers was hard to get used to.
- The picture resolution on the window screen was quite poor, making conning information and messages from waypoints hard to see.

## 9.3 Experiment Part II

### 9.3.1 New Experiment Setup



*Figure 36: Setup for Experiment, Part II: Added body support and platform for ECDIS*

On the basis of feedback and results from the first round of the experiment it was decided to perform another round with some changes made. One of the first weaknesses discovered with the first experiment was that the ECDIS screen which was placed on top of one of the console halves was affecting how participants chose to set up the workstation. Therefore a platform was built on the side of the projected screen. This also made it easier to change orientation on the workstation, with one less electrical wire to worry about. Another hole was made in the console for the wire running from the microcontroller inside, and out of the console side, such that the length of the wire would put less limitations on the freedom of movement of the workstation.

After the first experiment it became clear that the simple locking mechanism for the width regulation did not serve any real benefit. The intension of the wheel stoppers, was to keep a stable workstation and ensure that the console halves did not roll away by leaning against it. This proved not to be an issue, as the end stoppers that were installed on the platform

kept the console halves from rolling off when the workstation was in the split configuration, and the friction in the wheels were sufficient to keep the console stationary in the merged configuration. The wheel stoppers were rather hindering participants to change from merged to split setup because they required too much effort to operate. They were therefore removed.

Feedback from participants also suggested that a form of buttocks or side support like a stool or saddle to rest against. As this was presented as a need after roughly 14 minutes of work, it was decided to prototype a buttocks/hip support feature to the workstation and test the usefulness of this. Simple bars with handles that could be slid out and give support were fitted to each short side of the console halves.

A new and more comprehensive test scenario with longer duration was made to give the participants longer time to get used to different positions. A longer mission would also mean that the need for support would increase, hence give a better indication of the usefulness of the body support features, now including hand rails and buttocks/hip support. Like the first scenario, the new one started and finished respectively with undocking and docking. It started off with an easy part, with only the use of propellers and rudder necessary, but a more difficult middle section was created consisting of fine manoeuvring around a tight corner. For the new experiment, a different questionnaire (see Appendix B) was made. It was still interesting to map the different working positions, but the questions about understanding and user friendliness of the adjustments of the workstation were dropped. Instead a new question about the usefulness of the support features were added.

### 9.3.2 Participants

A number of 8 participants were tested during the second experiment. The participants were also this time all male students or PhDs at NTNU and none had previously participated in the first experiment. Instead of discovering all the adjustment possibilities by themselves as in the first experiment, each participant was this time given an introduction to the different setups before the mission started. The participants for the second test scenario spent between roughly 15 to 18 minutes to complete the mission, which makes the scenario slightly longer than in the first mission.

### 9.3.3 Body Support Features

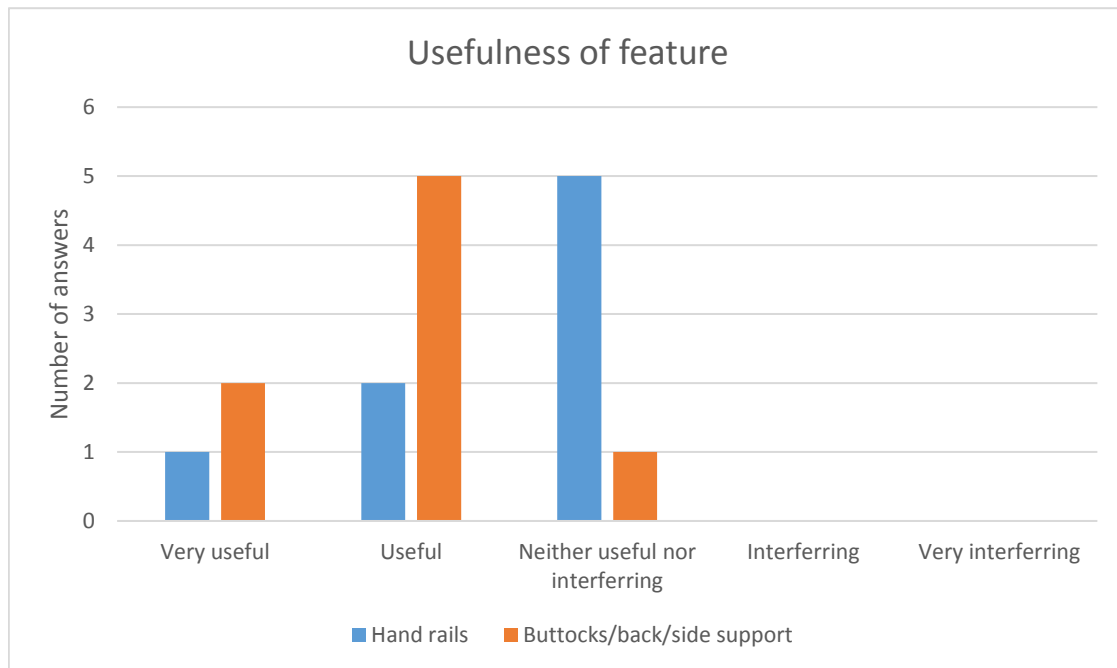

Figure 37: Determining the need for support features.

After completing the test scenario of the second mission, the participants were asked how useful the added body support features were or if they rather were perceived as interfering. The result from the survey show that none of the participants thought of the support features as interfering. All but one found use in the newly added buttocks/hip support feature, while more than half did not care about the hand rails. The results indicate that both support features might be useful, while the buttocks/hip support matters more than the hand rails for working conditions such as found in this test scenario.

### 9.3.4 Working Position

As mentioned in section 9.2.4, position E was found to be so impractical that it is not worth considering any further. It was decided to drop any evaluation of this setup for the second experiment.

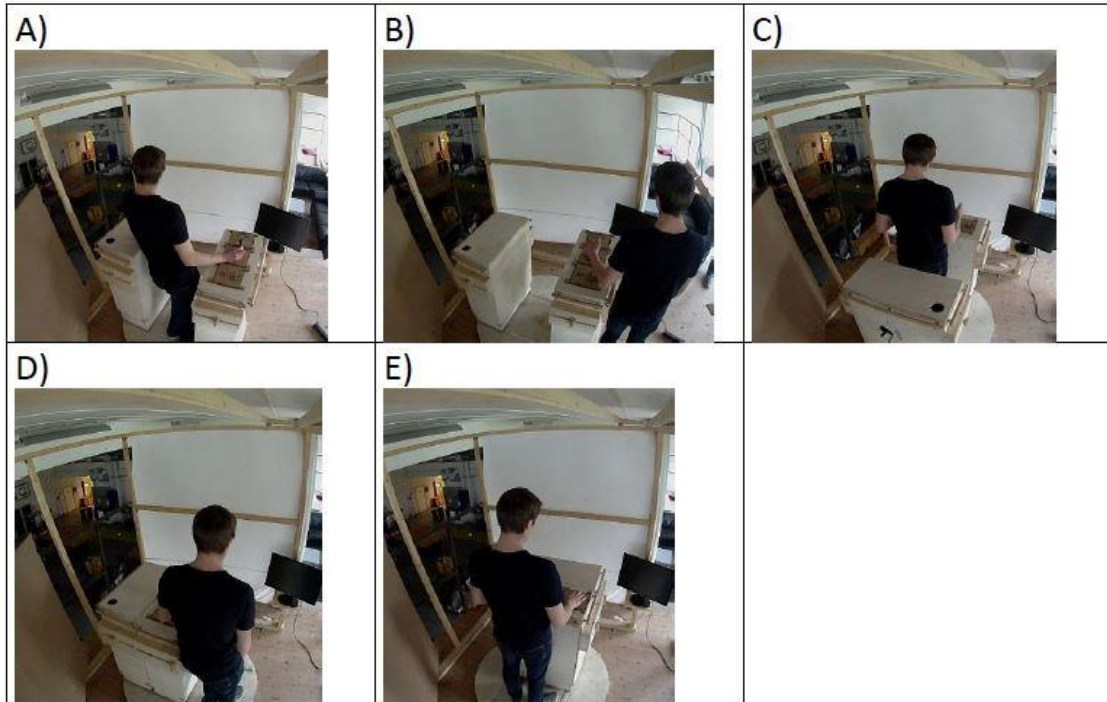

Figure 38: Updated sheet given to the participants for evaluation of the positions.

Figure 38 shows the positions that the participants were asked to evaluate, this time depicted rather than shown by figures, to decrease the possibility of misunderstanding the positions. Position E is the equivalent of Position F from the first experiment, and will from hereon continue to be called Position F. Positions B and D are mirrored compared to the first experiment, but they have nevertheless the same characteristics.

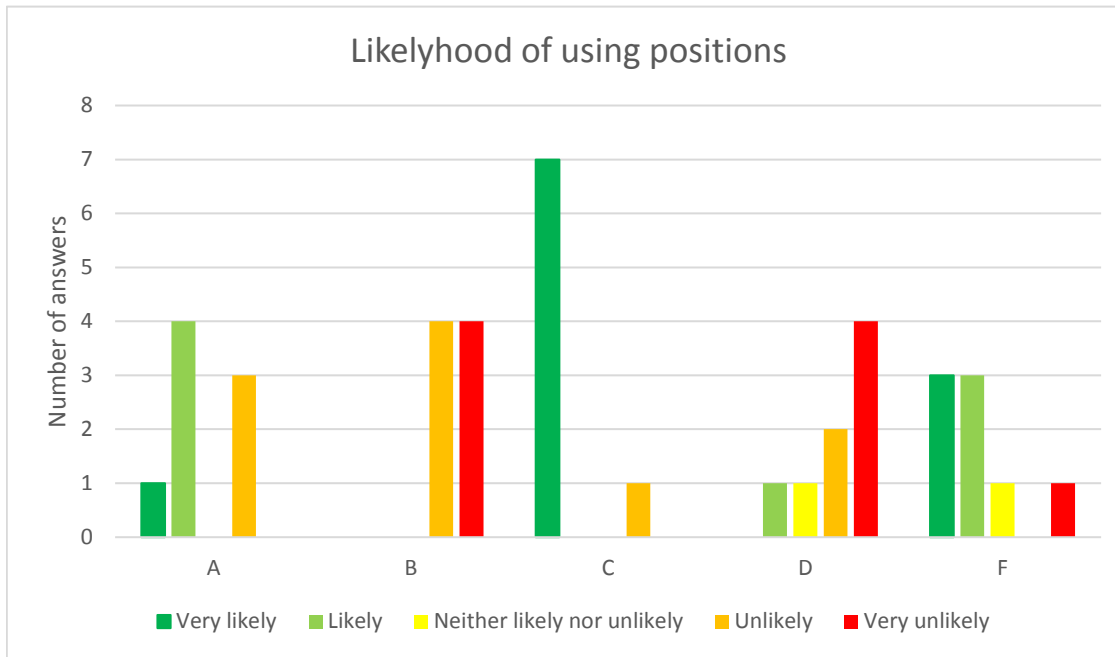

Figure 39: Opinions of each position for Experiment, part II

The results between the two experiments shows both differences and similarities in trends when it comes to preferences for the different positions. Position C looks to have taken lead as the most favourable position from Position F which was the preferred position in the first experiment. Positions B and C has both strengthened their trends from the first experiment of B being an unattractive and C a favourable position. Position D shows an opposing trend compared to the first experiment. It has now taken a turn from being a favourable position to a clearly unlikely position to be used. This might have been caused by the new placement of the ECDIS screen next to the projected window, which previously stood on the top of the console. It might also be a coincidence.

It was then time to combine the results for working positions from the two experiments. The following two figures show the overall result of position preference, and the overall position score calculated in the same way as in figure 34.

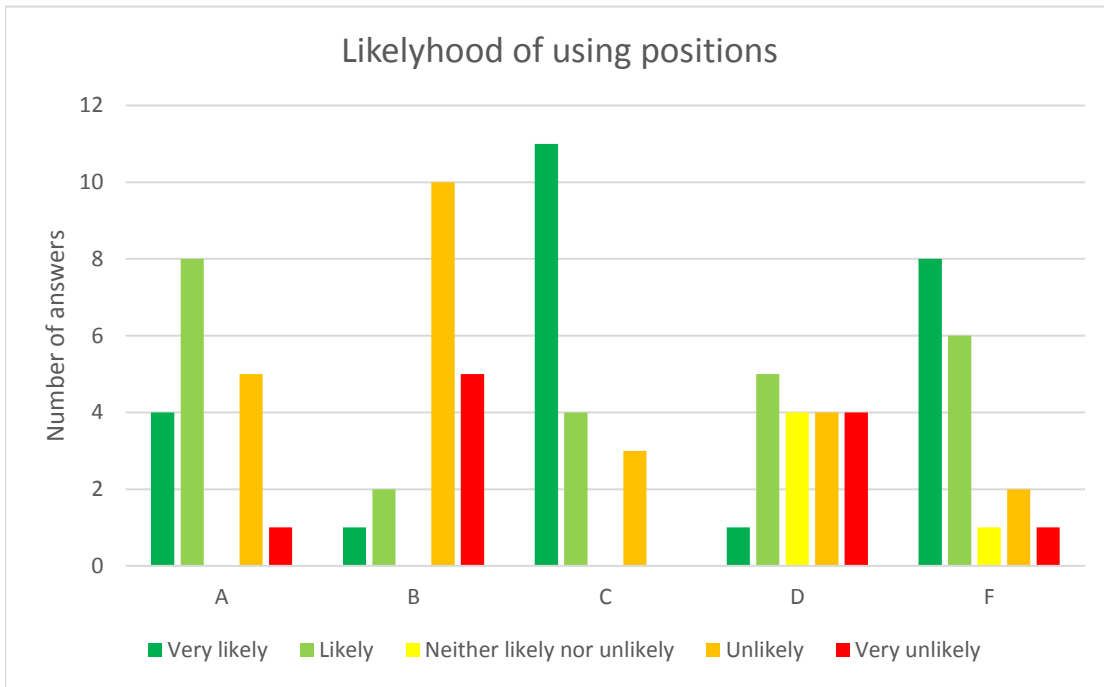

Figure 41: Opinions of each position, combined

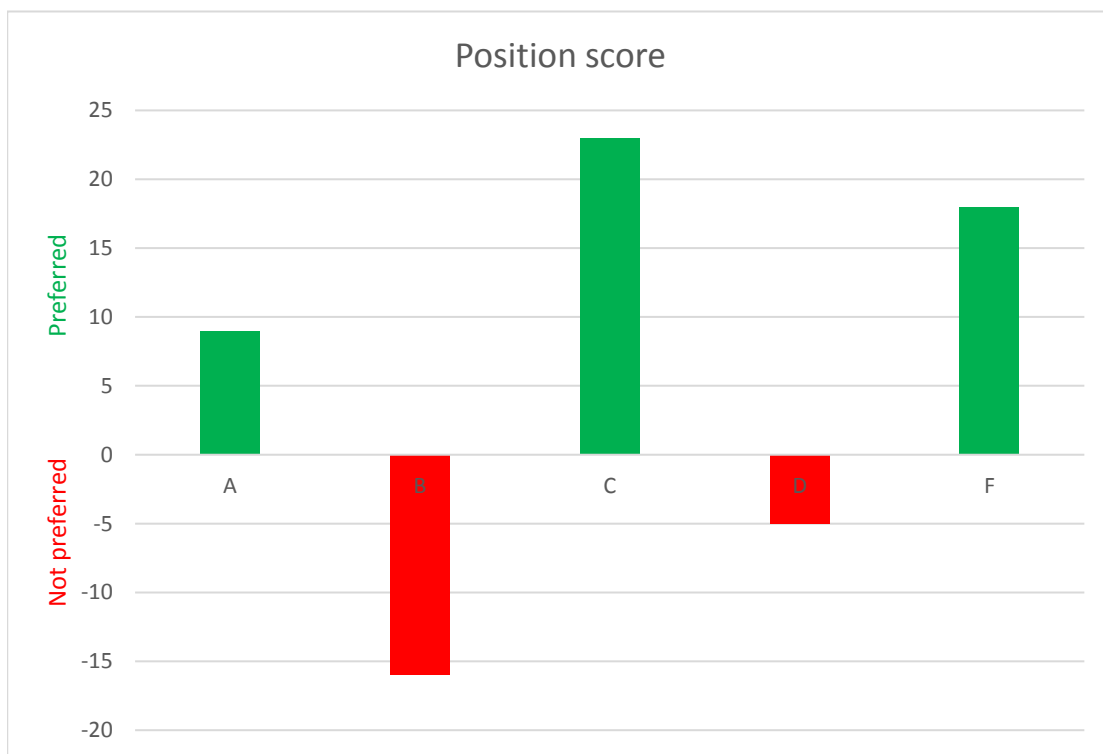

Figure 40: Position score, combined



With results from the two experiments combined with a total of 18 participants, the two most favoured positions are still C and F, though the combined results show that they have switched places, so that Position C might be the favourite compared to the first result, indicating that F might be slightly more preferred. The results from the second experiment surprisingly alters Position D's, status from "preferred" to "not preferred" while Position B's original status as not preferred is overall strengthened. Position A remains a well-favoured position.

### 9.3.5 General Insights

#### 9.3.5.1 Use of Body Support

After the buttocks/hip support was added, they remained unused most of the time, although some participants occasionally used it. Feedback from the participants indicate that the support prototype is too small to give enough rest, and that a support feature in the form of a stool/saddle would give more appropriate support. There are two main disadvantages with the prototype: one is that the short sides of the consoles give very little extension possibilities for the support bar, which also has to leave enough length inside their cassettes to be able to handle the load. The other that the height of the support bar and of the rest of its console half cannot be adjusted separately.

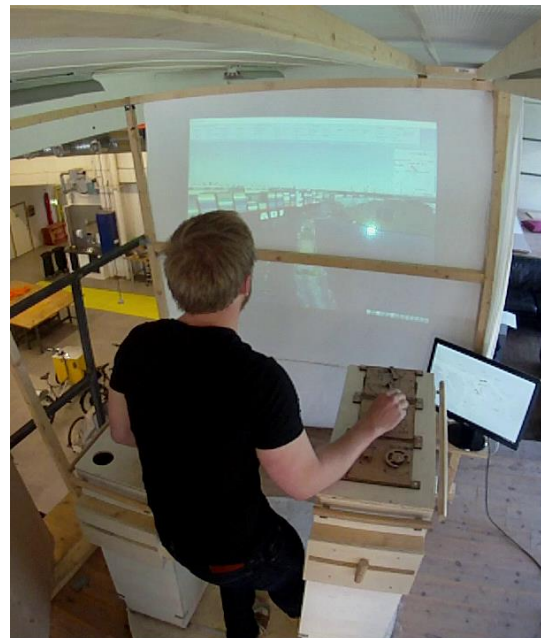

Figure 42: Leaning position

#### 9.3.5.2 Device Placement

It became clear after the second experiment that the layout of the control devices may have a big influence on which workstation setup that the user choose. The devices on the workstation prototype built for these experiments are quite large and consume the entire space on the panel of one of the console halves. The front thruster is located near the end of the console panel and the rudder all the way to the other end. This means that using positions A, B or D during operations that mainly require the use of the rudder, one would have to stand slightly behind the console to reach the rudder and hence not get much body

support from the console. This could mean that using Position C and F, with all the devices in front of the user are more attractive working positions in the case of this console panel. The situation would be different if the devices for controlling the ship were closer to each other and gathered at the front end. This would require less arm movement when switching between devices and give the opportunity to lean against the console side during the entire operation. Participants generally liked that the orientation of the devices could be changed in order to compensate for changing the orientation of the workstation, though some stated they would have liked the opportunity to also change the placement of the devices. This would be more challenging to solve due to the electric wires that run from each control device.

### 9.3.5.3 Consoles and Platform

Another realization during the second experiment was that taking the ECDIS away from the console and closer to the screen, made the console half without the devices more or less useless. Some participants pointed this out as confusing. The original thought behind the workstation was giving the user the option to be in the centre with all devices reachable by both hands. With all control devices placed on one console half and the ECDIS screen placed further away, the other console half, had few other purposes than giving body support. However, the need for storage space was noted as it could be observed that some participants used the vacant console half for holding coffee.

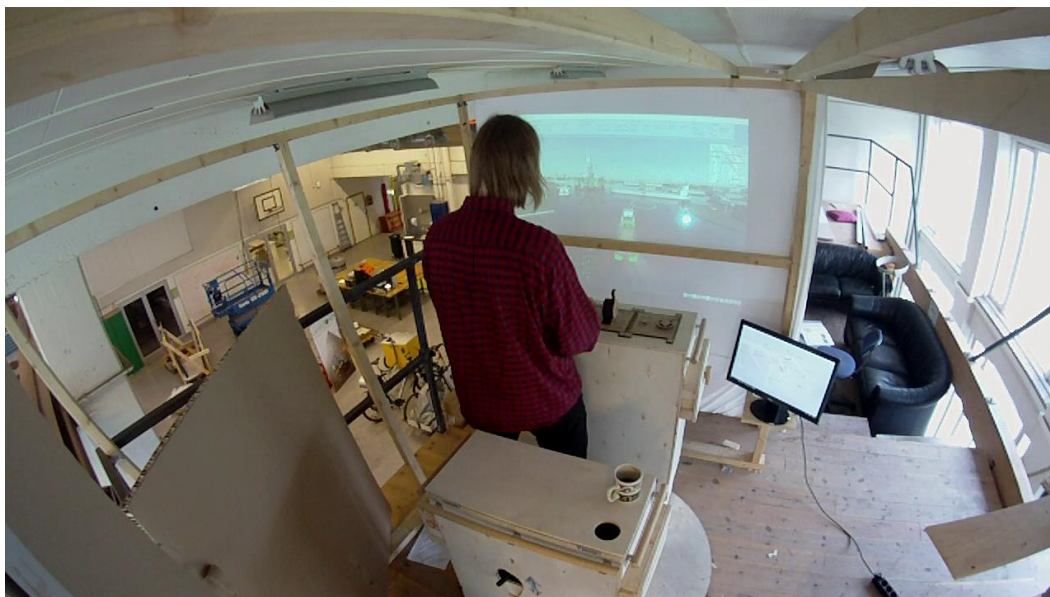

Figure 43: A place to put down the coffee cup is important for captains.

Some participants uttered that the platform supporting the console halves, which takes care of the function of changing the workstation orientation, is somewhat under-sized. The platform should have provided a larger surface such that the console halves could be placed further away from each other in split mode, such as for Position A and C. This would allow more freedom of space for the user in these positions. The small platform also leaves little place to stand on when the console halves are merged, such as for Position D and F.

## 10 Experimental Outcomes

### 10.1 Working Position

The experiment clearly indicates that people have different preferences regarding the setup of the SBW workstation. Overall it was positions C and F that were the most preferred positions, which indicates that people like to stand behind the console with the devices in front of them. These two positions are similar in the sense that both involves having the devices in front of the user, the difference is that position C has a console housing also behind the user. This provides a back support, which could be the reason why this position was slightly more popular. The slight difference between the two positions might also be random. Along with positions C and F, Position A was also preferred by some participants. This position enables the user to have the devices on one side, and get support from the other. As mentioned in section 9.2.4.3, some participants changed position according to the manoeuvring conditions. Typically from a relaxed position with the devices on the side under easy conditions, to rotating the workstation 90 degrees such that the devices end up in front of the user under more demanding conditions where the thrusters must be used. This experiment has only considered working positions with one direction of view. In reality, SBW operations mostly involves looking in different directions, and different directions can be of different relevance during different operations. This also speaks towards an adjustable workstation. Furthermore; regarding height adjustment, another aspect came to show the usefulness of this. A finding from the experiment was that the height adjustment was not only used in the beginning to set the correct height for the user, but was changed along the way to provide different leaning postures.

### 10.2 Adjustments

The fact that participants like different positions and that some likes to change their position under different conditions, does indicate that the adjustment functions presented in this thesis are useful, and would enhance a SBW workstation. However, the solutions that were provided in the workstation prototype are not meant as final solutions. The prototype was built in this way because it was easy, and could be done quickly with easily accessible materials. The best solutions are in the opinion of the author those mentioned in section 7.4, although final concepts depend largely upon how the workstation is designed in the end.

### 10.3 Device Placement

On the functional prototype, the devices were placed in the following order: Rudder, propellers, thrusters (aft and front). They were also given the opportunity to turn their orientation which is needed in order to reduce the risk of giving the wrong input. In section 6.2 the ergonomic effects of placing the devices were explored. It was concluded that it is favourable to place the devices in such a way that they are within the range of grasping as shown in section 6.2, and preferably not too far back if used often. The ideal placement would be in such a way that one has the opportunity lean ones elbows while using the devices. During the experiment this became a problem for positions A, B and D: The user will not get any elbow support when using the rudder, because it is placed too far back. This could be solved by gathering the devices closer to the other end. This could however affect the devices placement in an unfortunate way for the other positions. The experiment has not lead to any knowledge of any better way of placing the devices.

As pointed out by participants during part II of the experiment, with no devices placed on one of the console halves, this will become redundant for other uses than storage of miscellaneous objects and for providing body support. Both of these needs might also be prominent. A suggestion would be to have a main console which contains the devices, and a smaller, less space occupying console next to it for the purpose of storage and body support. This remains to be tested, but could be a good next step in the development of a future bridge wing workstation.

#### **Summing up the key findings:**

- Convenient working positions (depicted in Figure 38) ranging from most popular are positions C, F and A, indicating that there is a need for the adjustment functions.
- Pneumatic springs, wires and pulleys can solve height regulation cheap, provide easy adjustment and requires little space.
- Width and orientation adjustments are easy to solve by linear guides and placing the workstation on a turntable
- Devices should be placed such that elbow support is provided. If the user has the console to his side in relation to his direction of view, the devices should be placed far enough in front, so that the console might give elbow support.

# 11 Discussions

## 11.1 Limiting Factors of the Experiment

New knowledge has been gained from the experiment described in chapter 9, but it must be discussed in relation to the limiting factors. For the first, the ethnographic group of participants was very uniform. All participants were highly educated young males, either recently finished or studying engineering. It would also be useful to get female opinions, although men tend to share the big majority among ship officers as of today. The experiment should ideally also consist of a relevant group of bridge officers, especially regarding relevant working positions. It has during the project, been attempted to establish a lasting contact with people of nautical background, though rather unsuccessfully. It would also help to include nautical students and recently graduated ship officers who have a fresh perspective on bridge control systems. An advantage of this experiment may have been that the participants involved are relatively unbiased towards ship bridge design, and will therefore give more valuable feedback on likes and dislikes about the design than bridge officers, because they are to a great extent affected by the traditional workstation that they are used to. Nevertheless, it would have been ideal to include both unbiased people and people with nautical experience. The number of participants was also quite low, with only 18 in total, which is a scarce amount for providing useful data. More people would have been tested given more time. It would also have been useful to test people in part II of the experiment that had previously participated in part I, in order to compare the effects of the changes that were made with the new participants.

The test scenario that was created was rather unrealistic. The simulator was projected onto only one of the sides of the mock-up SBW. In a realistic scenario, the captain would have to turn his attention in many other directions, and they often look out of more than one of the sides of the SBW. In this experiment, the participants got a bird eye view over the boat that they were manoeuvring, which gave them the opportunity to focus their attention in a relatively small area on the projected screen. This also means that the participants will not get the same issues with the field of view as in real life. As discussed in chapter 5, a consequence of standing behind the console in relation to the user's direction of view, is that the console will disrupt lower parts of the field of view. This is left out in this experiment. The experiment should ideally have been conducted on a bridge wing of a proper ship bridge simulator such as found at SMSC in Trondheim, which was visited

during the pre-master's project. At such a facility, the devices could have been linked to the simulator software, and the testing environment much more realistic in terms of which working positions that would have been preferred.

One finding about the experiment was that the default setting of the workstation might have a significant impact on the chosen working position during the experiment. Once the participants see the prototype for the first time they might be fixated in the setup of the workstation at that time, effectively guiding the participants straight into a default position. This is why, during part II, that the participants were shown all adjustment possibilities prior to the scenario. Some participants took quite some time to learn how to control the boat using the devices given. Although maybe not very relevant in terms of working positions, the devices should perhaps be arranged with more logical input response. It was the thrusters in particular, that some participants found hard to get used to. One can also discuss the use of ECDIS in this experiment. The ECDIS is in most cases not being used during SBW operations, because the map is too big scaled. It was in this experiment arranged so that the participants would have more than one area to direct their attention.

Another thing to discuss is the effects of the changes made between part I and part II of the experiment. The changes were made mainly because of practical issues with the prototype, which caused some working positions to be more inconvenient than other, such as mentioned in section 9.2. the other reason was to gain more knowledge about the usefulness of support features under conditions such as tested. This is also likely to have changed the participants' perception of which are the most relevant working position. It might be, because of the fewer adjustment constrains, that part II of the experiment gives a more valid result. Both parts does however point out Positions A, C and F as the most important.

## 11.2 Further Work

For future research, the author will strongly recommend a better contact towards the relevant stakeholders, particularly bridge officers. Their opinions towards the design as experienced users will be valuable. They can also contribute with knowledge about practical limitations that affects the design and technical solutions quickly. Relevant people that might be useful to contact are SMSC, academic people and students at the nautical studies at NTNU in Ålesund, and at the Department of Marine Technology at NTNU in Trondheim. It is also advised for the further development to be more than one developer. Ideas are generated very inefficiently when there is no one to discuss with. One can easily

get fixated towards a particular design when working alone. As the first rule of the Hunter-Gatherer Model states, one should *never go hunting alone* (Steinert & Leifer, 2012) which means that product development in small, agile teams with diverse skills are much more efficient in the hunt for *The Big Idea*.

When it comes to the different working positions it would be interesting to dig deeper into the ergonomic effect of each of the relevant working positions. One could for instance set up a new experiment with a test scenario, set a time limit and measure the ergonomic consequences of each designated working position. It has been discovered that research on ergonomic design of workstations of integrated ship systems is not much considered during the development of such workstations. There seem to be a need for more research regarding this topic. It is recommended to have a more ergonomic perspective for future development of workstations at sea.

The experiment described in this thesis, does not have any statistical value. The participants were few and the data is based exclusively on personal opinions, or personal *hunches*. The data in chapter 9 can only be used as an indication of what the next step in the development will be. A more thorough statistical analysis on a prototype of higher resolution, might be beneficial for future work.

Based on the knowledge gained during this project and experiment, a new functional prototype should be built and tested. It would be interesting to test the idea of reducing the two-piece workstation down to just the one half, and another smaller construction with body supporting and storage possibilities. It is only fair to say that the development is still at an early stage, and there are still other designs that might be useful to test.

### 11.3 Evaluation of the Process

During this project, I have taken on the challenge of re-designing the SBW workstation by having both a technical and user-centred view. First from a Design Thinking and ergonomics perspective by testing with people it was proven which functions that a workstation should have. Then came the task of solving the technical aspect of providing such functions.

Even though it is useful to be aware of the technical issues during the design of a complex integrated system part such as a ship bridge workstation, one can however argue that it is too soon to decide which technical solution that should be used as the development is still



at an early stage. However, the solutions presented in chapter 7 are in my opinion likely to be promising. There is still work to be done in order to reach the future workstation. Still there are ideas to be tested before one can start to plan the nitty gritty details of a final design.

During this project, I have seen the difference of testing ideas as a team of two, and alone. Working as a team during the pre-master's project, made the process of generating ideas and testing over 30 prototypes possible. For every idea that was launched, there was immediately another perspective that led to a quick and efficient evaluation of whether to discard it or test the idea through prototyping. The prototype building could also happen much faster as two developers, and the assessment of each prototype was more efficient. There was still no definite answer to which workstation concept would be best at the end of the pre-master's project. During this master's thesis, the challenge had to be picked up in another fashion. The start was experienced as very slow moving as ideas lacked perspective. This resulted in a more ergonomic approach. Adjustment functions and control panel layout was considered based on which working positions could be relevant. This was later supported by an experimental approach by watching how people would stand during a SBW operation, using a functional prototype. The results led to new knowledge and a new idea for further testing.

## 12 Conclusion

This thesis has described the early-phase development of re-designing the workstations on ships. The work started with a design idea that concluded the work from a pre-project during the autumn of 2015. It was first identified which working positions that would be possible to use with a workstation that has the possibility to be split in two console parts and that can rotate.

The workstation design was then considered by how the size can be reduced and how the different devices ideally could be placed more ergonomically and user friendly. It was concluded that the devices that are used frequently and for long the periods, should be placed within grasping distance such that elbows can be supported and such that the hands does not have to reach far back. The workstation design has also been contemplated in relation to load conditions and health and safety.

A benchmarking and research phase led to different suggestions of how one might solve the adjustment functions that are required for the working positions that were presented. It was also discussed what might be the best solutions for the different adjustments.

The findings about working positions and adjustments led to the construction of a functional prototype. This was then used to conduct an experiment to see which postures people find the best to use, and thereby determine if the adjustment functions are useful. The experiment showed that height regulation is an important feature and that people tend to like having the devices in front, either standing behind the console in a merged position, or standing between the console parts getting back support from one of the console parts. People also like the split configuration rotated 90 degrees, with the devices on one side and getting side support from the other. The experiment also indicates that a support feature that gives a more or less sitting posture is desirable for longer operations.

The results led to the idea of having a workstation consisting of only one console part (half the size of the prototype presented in this thesis) with height regulation and rotation ability, and building another structure of less size to provide additional support and storage possibilities. This idea is yet to be tested.

## 13 Bibliography

- Brown, T. (2008). Design thinking. *harvard business review*, 86(6), 84.
- Buchenau, M., & Suri, J. F. (2000). *Experience prototyping*. Paper presented at the Proceedings of the 3rd conference on Designing interactive systems: processes, practices, methods, and techniques.
- Conwell, J. C., & Johnson, G. (1996). Experimental investigation of link tension and roller-sprocket impact in roller chain drives. *Mechanism and machine theory*, 31(4), 533-544.
- Das, B., & Sengupta, A. K. (1996). Industrial workstation design: a systematic ergonomics approach. *Applied Ergonomics*, 27(3), 157-163.
- Delleman, N. J., & Dul, J. (2002). Sewing machine operation: workstation adjustment, working posture, and workers' perceptions. *International Journal of Industrial Ergonomics*, 30(6), 341-353.
- DNV-GL. (2015). Rules for Classification - Ships - Part 4 Systems and Components - Chapter 9 Control and Monitoring Systems. Retrieved from <https://rules.dnvgl.com/docs/pdf/DNVGL/RU-SHIP/2016-01/DNVGL-RU-SHIP-Pt4Ch9.pdf>
- Dow, S. P., Heddleston, K., & Klemmer, S. R. (2009). *The efficacy of prototyping under time constraints*. Paper presented at the Proceedings of the seventh ACM conference on Creativity and cognition.
- Engineering\_360. Scissor Lifts Information. Retrieved from [http://www.globalspec.com/learnmore/material\\_handling\\_packaging\\_equipment/material\\_handling\\_equipment/scissor\\_lifts](http://www.globalspec.com/learnmore/material_handling_packaging_equipment/material_handling_equipment/scissor_lifts)
- Gerstenberg, A., Sjöman, H., Reime, T., Abrahamsson, P., & Steinert, M. (2015). A Simultaneous, Multidisciplinary Development and Design Journey—Reflections on Prototyping *Entertainment Computing-ICEC 2015* (pp. 409-416): Springer.
- Grandjean, K. H. E. K. E. (2005). *Fitting The Task To The Human*.
- Houde, S., & Hill, C. (1997). What do prototypes prototype. *Handbook of human-computer interaction*, 2, 367-381.
- Khurana, A., & Rosenthal, S. R. (1997). Integrating the fuzzy front end of new product development. *Sloan management review*, 38, 103-120.
- Kim, J., & Wilemon, D. (2002). Focusing the fuzzy front-end in new product development. *R&D Management*, 32, 269-279.
- Leifer, L. J., & Steinert, M. (2014). Dancing with ambiguity: Causality behavior, design thinking, and triple-loop-learning *Management of the Fuzzy Front End of Innovation* (pp. 141-158): Springer.
- Lim, Y.-K., Stolterman, E., & Tenenberg, J. (2008). The anatomy of prototypes: Prototypes as filters, prototypes as manifestations of design ideas. *ACM Transactions on Computer-Human Interaction (TOCHI)*, 15(2), 7.
- Lützhöft, M. (2004). "The technology is great when it works": Maritime Technology and Human Integration on the Ship's Bridge.
- Meinel, C., & Leifer, L. (2010a). Design thinking research. *Design thinking: understand—improve—apply*. Springer, Heidelberg.
- Meinel, C., & Leifer, L. (2010b). *Design thinking research*.
- Moenaert, R. K., De Meyer, A., Souder, W. E., & Deschoolmeester, D. (1995). R&D/marketing communication during the fuzzy front-end. *Engineering Management, IEEE Transactions on*, 42(3), 243-258.
- Murphy, S. A., & Kumar, V. (1997). The front end of new product development: a Canadian survey. *R&D Management*, 27(1), 5-15. doi:10.1111/1467-9310.00038

- Reid, S. E., & De Brentani, U. (2004). The fuzzy front end of new product development for discontinuous innovations: A theoretical model. *Journal of product innovation management*, 21(3), 170-184.
- Reinertsen, D. G. (1999). Taking the fuzziness out of the fuzzy front end. *Research-Technology Management*, 42(6), 25-31.
- Slater, N., & Chironis, N. P. (2001). *Mechanisms and mechanical devices sourcebook* (Vol. 3): McGraw-Hill New York.
- Smith, P., & Reinertsen, D. (1991). *Developing new products in half the time*: Van Nostrand Reinhold Books, New York, NY.
- Snowden, D. J., & Boone, M. E. (2007). A leader's framework for decision making. *harvard business review*, 85(11), 68.
- Steinert, M., & Leifer, L. J. (2012). 'Finding One's Way': Re-Discovering a Hunter-Gatherer Model based on Wayfaring. *International Journal of Engineering Education*, 28(2), 251.
- Ulrich, K. T., & Eppinger, S. (2012). *Product Design and Development, 2012*: McGraw-Hill, New York, NY.
- Varanasi, K. K., & Nayfeh, S. A. (2004). The dynamics of lead-screw drives: low-order modeling and experiments. *Journal of dynamic systems, measurement, and control*, 126(2), 388-396.
- Vezina, N., Tierney, D., & Messing, K. (1992). When is light work heavy? Components of the physical workload of sewing machine operators working at piecework rates. *Applied Ergonomics*, 23(4), 268-276.
- Viswanathan, V. K., & Linsey, J. S. (2013). Role of sunk cost in engineering idea generation: an experimental investigation. *Journal of Mechanical Design*, 135(12), 121002.
- Wilkinson, G. (1974). III.—Ergonomics in Ship Design. *Journal of Navigation*, 27(04), 471-478.
- Woodford, C. (2015). Gas springs. Retrieved from <http://www.explainthatstuff.com/gassprings.html>

## Appendix A

### Appendix A – Questionnaire for Experiment, Part I

# Appendix A

## SBW - workstation

### \* 1. Gender

- Male  
 Female  
 Other

### \* 2. Age

- 18 - 24  
 25 - 29  
 30 - 39  
 40 - 49  
 50 - 59  
 60 - 69

### \* 3. How well did you understand the following functions?

	Very good	Good	Neither good nor bad	Bad	Very bad
Height adjustment	<input type="radio"/>	<input type="radio"/>	<input type="radio"/>	<input type="radio"/>	<input type="radio"/>
Width adjustment	<input type="radio"/>	<input type="radio"/>	<input type="radio"/>	<input type="radio"/>	<input type="radio"/>
Orientation adjustment	<input type="radio"/>	<input type="radio"/>	<input type="radio"/>	<input type="radio"/>	<input type="radio"/>

### 4. How easy to use are the following functions?

	Very easy	Easy	Neither easy nor difficult	difficult	Very difficult
Height adjustment	<input type="radio"/>	<input type="radio"/>	<input type="radio"/>	<input type="radio"/>	<input type="radio"/>
Width adjustment	<input type="radio"/>	<input type="radio"/>	<input type="radio"/>	<input type="radio"/>	<input type="radio"/>
Orientation adjustment	<input type="radio"/>	<input type="radio"/>	<input type="radio"/>	<input type="radio"/>	<input type="radio"/>

### 5. How likely are you to use the positions as shown on the paper?

	Very likely	Likely	Neither likely nor unlikely	Unlikely	Very unlikely
A	<input type="radio"/>	<input type="radio"/>	<input type="radio"/>	<input type="radio"/>	<input type="radio"/>
B	<input type="radio"/>	<input type="radio"/>	<input type="radio"/>	<input type="radio"/>	<input type="radio"/>
C	<input type="radio"/>	<input type="radio"/>	<input type="radio"/>	<input type="radio"/>	<input type="radio"/>
D	<input type="radio"/>	<input type="radio"/>	<input type="radio"/>	<input type="radio"/>	<input type="radio"/>
E	<input type="radio"/>	<input type="radio"/>	<input type="radio"/>	<input type="radio"/>	<input type="radio"/>
F	<input type="radio"/>	<input type="radio"/>	<input type="radio"/>	<input type="radio"/>	<input type="radio"/>

### 6. Are there anything you like in particular about the workstation?

### 7. Are there anything you dislike in particular about the workstation?

## Appendix B

### Appendix B – Questionnaire for Experiment, Part II

## \* 1. Gender

- Male  
 Female  
 Other

## \* 2. Age

- 18 - 24  
 25 - 39  
 40 - 49  
 50 - 59  
 60 - 69

## \* 3. How likely are you to use the following positions?

	Very likely	Likely	Neither likely nor unlikely	Unlikely	Very unlikely
A	<input type="radio"/>	<input type="radio"/>	<input type="radio"/>	<input type="radio"/>	<input type="radio"/>
B	<input type="radio"/>	<input type="radio"/>	<input type="radio"/>	<input type="radio"/>	<input type="radio"/>
C	<input type="radio"/>	<input type="radio"/>	<input type="radio"/>	<input type="radio"/>	<input type="radio"/>
D	<input type="radio"/>	<input type="radio"/>	<input type="radio"/>	<input type="radio"/>	<input type="radio"/>
E	<input type="radio"/>	<input type="radio"/>	<input type="radio"/>	<input type="radio"/>	<input type="radio"/>

## \* 4. How useful are the following features?

	Very useful	Useful	Neither useful nor interfering	Interfering	Very interfering
Hand rails	<input type="radio"/>	<input type="radio"/>	<input type="radio"/>	<input type="radio"/>	<input type="radio"/>
Buttocks/back/side support	<input type="radio"/>	<input type="radio"/>	<input type="radio"/>	<input type="radio"/>	<input type="radio"/>

## 5. Are there any other features that you would like to have on your bridge wing workstation?

## 6. Are there anything you dislike in particular about the workstation?

## 7. Are there anything you like in particular about the workstation?



## Appendix C

### Appendix C – Arduino Code for Console Devices

## Appendix C

```
// Input pin decleration
const int prop = A0;           // Main propeller potmeter pin
const int leftRudderPin = A2; // Bow Thruster potmeter pin
const int rightRudderPin = A1; // Aft Thruster potmeter pin
const int bowThr = A3;        // Rudder potmeter pin
const int aftThr = A4;        // Rudder potmeter pin

// Joystick axis decleration
unsigned int propeller = 0;
unsigned int bowThruster = 0;
unsigned int aftThruster = 0;
unsigned int leftRudder = 0;
unsigned int rightRudder = 0;

String serialSend = "0000000000000000";

void setup()
{
  Serial.begin(9600);
  Joystick[0].begin();
  Joystick[1].begin();
}

void loop()
{
  // ----- Reading of controller -----
  propeller = analogRead(prop);
  int propPercent = map(propeller, 0, 1023, 100, -100);
  propeller = map(propeller, 0, 1023, 127, -127);
  Joystick[0].setYAxis(propeller);

  rightRudder = analogRead(rightRudderPin);
  int RightRudderPercent = map(rightRudder, 0, 1023, 100, -100);
  rightRudder = map(rightRudder, 0, 1023, -127, 127);
  Joystick[1].setYAxis(rightRudder);

  bowThruster = analogRead(bowThr);
  int BTPercent = map(bowThruster, 0, 1023, -100, 100);
  bowThruster = map(bowThruster, 0, 1023, 127, -127);
  Joystick[0].setXAxis(bowThruster);

  aftThruster = analogRead(aftThr);
  int ATPercent = map(aftThruster, 0, 1023, -100, 100);
  aftThruster = map(aftThruster, 0, 1023, 127, -127);
  Joystick[1].setXAxis(aftThruster);

  // ----- Communication string decleration -----
  String dirProp = checkDir(propeller);
  String dirBT = checkDir(bowThruster);
  String dirAT = checkDir(aftThruster);
}
```

## Appendix C

```
String dirRightRudder = checkDir(rightRudder);
String strValueProp = int2str(abs(propPercent));
String strValueBT = int2str(abs(BTPercent));
String strValueAT = int2str(abs(ATPercent));
String strValueRightRudder = int2str(abs(RightRudderPercent));

Serial.println(dirProp + strValueProp + dirBT + strValueBT + dirAT + strValueAT +
dirRightRudder + strValueRightRudder);
// debugger();
// ----- END OF VOID LOOP -----
}

String checkDir(int val) {
  String a = "0";
  if (val <= 0) a = "0";
  else a = "1";
  return a;
}



String int2str(int a) {
  String res;
  if (a < 10)
  {
    res = "00" + String(a);
  }
  else if (a < 100)
  {
    res = "0" + String(a);
  }
  else
  {
    res = String(a);
  }
  return res;
}

void debugger() {
  Serial.print("\t");
  Serial.print("A");
  Serial.print("\t");
  Serial.print("A");
  Serial.print("\t");
}
}
```

## Appendix C

Appendix D

Appendix D – Risk Assessment Form

NTNU		Utarbeidet av		Nummer		Dato	
		HMS-avd.		HMSRV2601		22.03.2011	
HMS		Godkjent av		Rektor		Erstatter	
						01.12.2006	
Kartlegging av risikofylt aktivitet							
							

Enhet: Department of engineering design and materials

Dato: 2016.02.02

Linjeleder:

Deltakere ved kartleggingen (m/ funksjon): Martin Steinert, veileder/ Ferdinand O. Solvang, student  
(Ansv. veileder, student, evt. medveiledere, evt. andre m. kompetanse)

Kort beskrivelse av hovedaktivitet/hovedprosess: Masteroppgave Ferdinand O. Solvang. Next generation ship bridge

Er oppgaven rent teoretisk? (JA/NEI): Nei «JA» betyr at veileder innestår for at oppgaven ikke inneholder noen aktiviteter som krever risikovurdering. Dersom «JA»: Beskriv kort aktiviteten i kartleggingskjemaet under. Risikovurdering trenger ikke å fylles ut.

Signaturer: Ansvarlig veileder: Martin Steinert

Student: Ferdinand O. Solvang

ID nr.	Aktivitet/prosess	Ansvarlig	Eksisterende dokumentasjon	Eksisterende sikringsstiltak	Lov, forskrift o.l.	Kommentar
1	Bruk av Trolllabs workshop.	FOS	Romkort	Romkort		
1a	Bruk av roterende maskineri	FOS	Maskinens brukermanual	Ukjent	Ukjent	
1b	Bruk av laserkutter	FOS	Maskinens brukermanual	Ukjent	Ukjent	
1c	Bruk av 3D printer	FOS	Maskinens brukermanual	Ukjent	Ukjent	
1d	Bruk av skjæreverktøy	FOS	Ukjent			
1e	Bruk av sementtøyningsmidler (lim og lignende.)	FOS	Produktets brukermanual og datablad	Datablad	Ukjent	
2	Tilstedeværelse ved arbeid utført av andre.	Andre	Andres HMSRV2601	Andres HMSRV2601	Prosessavhengig	

NTNU	<b>Kartlegging av risikofylt aktivitet</b>				Utarbeidet av	Nummer	Dato	
					HMS-avd.	HMSRV2601	22.03.2011	
HMS	Godkjent av		Erstatter					
		Rektor	01.12.2006					

3	Ekperimentelt arbeid	FOS	Egen risikovurdering- må gjøres for hvert enkelt eksperiment		Prosessavhengig	
---	----------------------	-----	--	--	-----------------	--

## Risikovurdering

Utarbeidet av	Nummer	Dato
HMS-avd.	HMSRV2601	22.03.2011
Godkjent av	Erstatter	
Rektor		01.12.2006



ID nr	Aktivitet fra kartleggings-skjemaet	Mulig uønsket hendelse/ belastning	Vurdering av sannsynlighet (1-5)	Vurdering av konsekvens:				Risiko-Verdi (menneske)	Kommentarer/status Forslag til tiltak
				Menneske (A-E)	Ytre miljø (A-E)	Øk/ materiell (A-E)	Om-dømme (A-E)		
1	Bruk av Trolllabb workshop.								
1a-i	Bruk av roterende maskineri	Stor kuttskade	2	D	A	A	D	2D	Sørg for at roterende deler er tilstrekkelig sikret/dekket. Vær nøye med opplæring i bruk av maskineri.
1a-ii		Liten kuttskade	3	B	A	A	A	3B	Vær nøye med opplæring i bruk av maskineri. Ikke ha løse klær/tilbehør på kroppen.
1a-iii		Klæmskade	2	D	A	A	C	2D	Vær nøye med opplæring i bruk av maskineri. Ikke ha løse klær/tilbehør på kroppen.
1a-iv		Flygende spon/gjenstander	3	C	A	A	B	3C	Bruk øyevern og tildekk hurtig roterende deler (Fres og lignende.)
1a-v		Feil bruk-> ødelagt utstyr	3	A	A	C	A	3C	Vær nøye med opplæring i bruk av maskineri
1b-i	Bruk av laserkutter	Klæmskade	2	D	A	A	C	2D	Vær nøye med opplæring i bruk av maskineri. Ikke ha løse klær/tilbehør på kroppen.
1b-ii		Brannskade	3	B	A	A	A	3B	Vær nøye med opplæring i bruk av maskineri. Bruk hansker ved håndtering av varme materialer.



## Risikovurdering

Utarbeidet av	Nummer	Dato
HMS-avd.	HMSRV2601	22.03.2011
Godkjent av	Erstatter	
Rektor		01.12.2006



1b-iii	Øyeskade-laser	2	D	A	A	A	C	2D	Bruk øyevern! Skru av laser når maskinen ved oppsett.
1b-iv	Brann	2	B	A	D	C	2B	Vær nøye med opplæring i bruk av maskin. Ha slukkeutstyr tilgjengelig	
1c-i	Bruk av 3D-printer	3	B	A	A	A	3B	Vær nøye med opplæring i bruk av maskin.	
1c-ii	Innhalering av plast/printermateriale	5	A	A	A	A	5A	Bruk åndedrettsvern/ vernebriller	
1c-iii	Feil bruk-> ødelagt maskineri	3	A	A	C	A	3A	Vær nøye med opplæring i bruk av maskin.	
1d-i	Bruk av skjæreverktøy	2	D	A	A	D	2D	Bruk skapre verktøy og riktig skjæreunderlag	
1d-ii	Liten kuttskade	3	B	A	A	A	3B	Bruk skapre verktøy og riktig skjæreunderlag	
1e-i	Bruk av samentøyningsmidler (lim og lignende.)	2	D	A	A	B	2D	Bruk øyevern, ha datablad tilgjengelig	
1e-ii	Eksposering hud	4	A	A	A	A	4A	Bruk hansker, ha datablad tilgjengelig	
1e-iii	Eksposering åndedrett	4	A	A	A	A	4A	Bruk åndedrettsvært/ god ventilasjon. Ha datablad tilgjengelig.	

NTNU		Risikovurdering		Utarbeidet av		Nummer		Dato	
				HMS-avd.		HMSRV2601		22.03.2011	
HMS				Godkjent av		Erstatter			
				Rektor				01.12.2006	
									

1e-iv		Søi	4	A	B	A	A	A	4A	Ha papir/ rengjøringsmaterieill tilgjengelig. Ha datablad tilgjengelig.
2	Tilstedeværelse ved arbeid utført av andre.	Se andres risikovurdering om sikkerhet betviles.	3	C	C	C	C	C	3C	Hold et øye med hva som foregår rundt deg.
3-i	Eksperimentelt arbeid	Vann-drukning	1	A	A	A	D	1E	1E	Bruk redningsvest i båt og lignende.
3-ii		Elektrisitet- strøm	3	B	A	A	A	3V	3V	Typisk lite energi involvert. Bruk isolerte verktøy
3-iii		Ulykke på skip	1	D	D	B	B	1D	1D	Følg regler og prosedyrer ombord

NTNU	<b>Risikovurdering</b>			Utarbeidet av	Nummer	Dato
				HMS-avd.	HMSRV2601	22.03.2011
HMS				Godkjent av	Erstatter	
				Rektor		01.12.2006
						

### Sannsynlighet vurderes etter følgende kriterier:

Svært liten 1	Liten 2	Middels 3	Stor 4	Svært stor 5
1 gang pr 50 år eller sjeldnere	1 gang pr 10 år eller sjeldnere	1 gang pr år eller sjeldnere	1 gang pr måned eller sjeldnere	Skjer ukjentlig

### Konsekvensen vurderes etter følgende kriterier:



Gradering	Menneske	Ytre miljø Vann, jord og luft	Øk/materiell	Omdømme
<b>E</b> Svært Alvorlig	Død	Svært langvarig og ikke reversibel skade	Drifts- eller aktivitetsstans > 1 år.	Troverdighet og respekt betydelig og varig svekket
<b>D</b> Alvorlig	Alvorlig personskade. Mulig uførhet.	Langvarig skade. Lang restitusjonstid	Driftsstans > ½ år Aktivitetsstans i opp til 1 år	Troverdighet og respekt betydelig svekket
<b>C</b> Moderat	Alvorlig personskade.	Mindre skade og lang restitusjonstid	Drifts- eller aktivitetsstans < 1 mnd	Troverdighet og respekt svekket
<b>B</b> Liten	Skade som krever medisinsk behandling	Mindre skade og kort restitusjonstid	Drifts- eller aktivitetsstans < 1uke	Negativ påvirkning på troverdighet og respekt
<b>A</b> Svært liten	Skade som krever førstehjelp	Ubetydelig skade og kort restitusjonstid	Drifts- eller aktivitetsstans < 1dag	Liten påvirkning på troverdighet og respekt

### Risikoverdi = Sannsynlighet x Konsekvens

Beregn risikoverdi for Menneske. Enheten vurderer selv om de i tillegg vil beregne risikoverdi for Ytre miljø, Økonomi/materiell og Omdømme. I så fall beregnes disse hver for seg.

### Til kolonnen "Kommentarer/status, forslag til forebyggende og korrigerende tiltak":

Tiltak kan påvirke både sannsynlighet og konsekvens. Prioriter tiltak som kan forhindre at hendelsen inntreffer, dvs. sannsynlighetsreduserende tiltak foran skjerpet beredskap, dvs. konsekvensreduserende tiltak.

NTNU	Risikomatrixe			utarbeidet av	Nummer	Dato	
				HMS-avd.	HMSRV/2604	08.03.2010	
HMS/KS				godkjent av		Erstatter	
				Faktor		09.02.2010	

## MATRISSE FOR RISIKOVURDERINGER ved NTNU

<b>KONSEKVENNS</b>					
Svært alvorlig	E1	E2	E3	E4	E5
Alvorlig	D1	D2	D3	D4	D5
Moderat	C1	C2	C3	C4	C5
Liten	B1	B2	B3	B4	B5
Svært liten	A1	A2	A3	A4	A5
	Svært liten	Liten	Middels	Stor	Svært stor
<b>SANNSYNLIGHET</b>					

**Prinsipp over akseptkriterium. Forklaring av fargene som er brukt i risikomatrixen.**

Farge	Beskrivelse
Rød	Uakseptabel risiko. Tiltak skal gjennomføres for å redusere risikoen.
Gul	Vurderingsområde. Tiltak skal vurderes.
Grønn	Akseptabel risiko. Tiltak kan vurderes ut fra andre hensyn.

Appendix E

Appendix E – Pre-Master's Thesis

**Erik Andreas Karlsson**

**Ferdinand Oddsønn Solvang**

# A human-centred approach to the development of a ship bridge wing

**Project Thesis in Mechanical Engineering**

**Trondheim, June, 16**

**Supervisor: Ph.D. Martin Steinert**

**Teaching Assistant: Matilde Bisballe Jensen, Heikki Sjøman**

**Norwegian University of Science and Technology**

**Faculty of Engineering Science and Technology**

**Department of Engineering Design and Materials**

 **NTNU**  
Norwegian University of  
Science and Technology





## Abstract

The shipping industry is one of the world's most important trading businesses, carrying the majority of international trade items. The recreational part of shipping, such as cruises, is also a popular way to spend the holidays for many passengers across the world. Therefore, it is a huge responsibility resting on the captains and their crew to sail safely across the world, as well as shorter domestic routes, bringing both cargo and passengers safely to their destination. In this research, we set out to explore the possibilities of the bridge wing, trying to innovate the way one controls the ship, and the design of the bridge wing. The traditional design of a ship bridge wing forces the captain to operate under stressful conditions, often with difficult physical positions. A design thinking mindset, in combination with the wayfaring model is used to innovate the bridge wing, with a user-centered approach. The areas of focus are bridge wing design, FOV, console design and informational feedback. More than 30 prototypes has been made, tested and evaluated during the course of this project. We have come up with a new design suggestion for the bridge wing console, defined needs and limitations of the bridge wing and suggested a new environment, expanding the freedom of the captain and crew during docking and undocking. The suggestions made in this research are concepts, meaning that an in-depth analysis should be done at a later stage, as well as the final optimizations. Suggestions to further directions are also presented.





## Acknowledgements

This project originates from initial work at the research facility TrollLabs at NTNU assigned by Kongsberg Maritime during the summer of 2015. The research done during the summer, led to a good foundation for further product development, which ultimately resulted in this report. First, we would like to thank our advisor Martin Steinert for introducing us to this assignment and Kongsberg Maritime, and for welcoming us at TrollLabs and making “mini-trolls” out of us. Through TrollLabs, we have been given valuable insight in early stage product development. We must also thank our teaching assistant Heikki Sjöman and Matilde Bisballe Jensen for helping us move forward in times of need. Special thanks goes to the officers at M/S Color Magic and M/S Polarlys for kindly letting us aboard their bridge and learn about their work, as well as the visit and trial run at SMSC. At last, we thank Pål Gunnar Eie and Espen Strange from Kongsberg Maritime for presenting this challenge and giving us the opportunity to work with them.



---

## Table of contents

<b>ABSTRACT</b> .....	<b>5</b>
<b>ACKNOWLEDGEMENTS</b> .....	<b>7</b>
<b>TABLE OF CONTENTS</b> .....	<b>9</b>
<b>LIST OF FIGURES</b> .....	<b>12</b>
<b>LIST OF TABLES</b> .....	<b>14</b>
<b>ABBREVIATIONS AND DEFINITIONS</b> .....	<b>15</b>
<b>1 THE POTENTIAL OF THE SHIP BRIDGE WING</b> .....	<b>16</b>
1.1 The challenge .....	16
1.2 Motivation.....	16
1.3 Bridge wing design .....	17
1.4 Console design .....	17
1.5 Regulations .....	18
<b>2 EARLY PHASE, HUMAN-CENTRED APPROACH</b> .....	<b>19</b>
2.1 The Fuzzy Front-End Phase.....	19
2.2 Design thinking philosophy .....	19
2.3 Wayfaring as a product development process .....	20
2.4 Prototypes .....	21
<b>3 APPLICATION OF THEORY</b> .....	<b>23</b>
3.1 Mind-set and process .....	23
3.2 Prototyping and testing .....	24
3.3 Process evaluation.....	24
<b>4 BRIDGE WING PRECONDITIONS</b> .....	<b>25</b>
4.1 Definitions.....	25
4.2 Limitations .....	25
4.3 Stakeholder analysis.....	25

---

<b>5 EXPLORING TODAY'S SHIP BRIDGE .....</b>	<b>28</b>
5.1 Visits .....	28
5.1.1 Color Line 1 .....	28
5.1.2 Color Line 2 .....	28
5.1.3 SMSC, Ship Simulator .....	29
5.1.4 Hurtigruten .....	30
5.2 Pain Points at the Ship Bridge Wing.....	32
<b>6 INFORMATION TECHNOLOGY.....</b>	<b>33</b>
6.1 Initial Technology Analysis .....	33
6.2 Testing Technologies .....	33
6.2.1 Augmented Reality and Head-Up Display .....	34
6.2.2 Panel Controllers.....	35
<b>7 CONSOLE DEVELOPMENT.....</b>	<b>36</b>
7.1 Simulator.....	36
7.2 Ceiling Console.....	37
7.2.1 First Version – C01 .....	37
7.2.2 Second Version – C02 .....	37
7.2.3 Third and Fourth Version – C03 & C04 .....	38
7.3 Floor Console.....	38
7.3.1 First and Second Version – F01 & F02 .....	38
7.3.2 Third Version – F03.....	39
7.3.3 Fourth Version – F04.....	40
7.3.4 Fifth Version – F05 .....	41
7.3.5 Sixth Version – F06 .....	41
7.4 Rail Console – R01 & R02 .....	42
7.5 Body console – B01 & B02 .....	43

---

<b>8 FIELD OF VIEW ANALYSIS .....</b>	<b>44</b>
8.1 Field of view analysis – setup 1 .....	44
8.2 Field of View Analysis – setup 2.....	45
<b>9 OUTCOMES .....</b>	<b>47</b>
9.1 Bridge wing environment .....	47
9.1.1 The captain’s position .....	47
9.1.2 The First Mate’s position.....	48
9.1.3 Field of view .....	48
9.2 Console design.....	49
<b>10 DISCUSSION AND FURTHER WORK.....</b>	<b>54</b>
<b>11 THE DEVELOPMENT PROCESS OUTCOME .....</b>	<b>57</b>
<b>12 CONCLUSION .....</b>	<b>58</b>
<b>13 BIBLIOGRAPHY .....</b>	<b>60</b>
<b>APPENDIX A – ASSIGNMENT TEXT .....</b>	<b>62</b>
<b>APPENDIX B – RISK ASSESSMENT .....</b>	<b>65</b>

## List of Figures

Figure 1: Color Magic with highlighted ship bridge wing .....	17
Figure 2: A traditional ship bridge wing console.....	18
Figure 3: Generic stage-gate model .....	19
Figure 4: Design thinking model. ....	20
Figure 5: Wayfaring model, and probing activity.....	21
Figure 6: Different resolution prototypes. ....	22
Figure 7: Stakeholder and value chain map. ....	27
Figure 8: First Mate in action at SBW .....	29
Figure 9: Small floor window .....	31
Figure 10: Augmented reality prototype.....	34
Figure 11: Various prototypes of controllers .....	35
Figure 12: Simulator panel.....	36
Figure 13: Second ceiling console. ....	37
Figure 14: Ceiling console, version three .....	38
Figure 15: Floor console, version two. ....	38
Figure 16: Third version floor console .....	39
Figure 17: Fourth version floor console.....	40
Figure 18: Floor console, version five .....	41
Figure 19: Version six of the floor console .....	41
Figure 20: Rail console, second version .....	42
Figure 21: Second version body console with side panel controllers.....	43
Figure 22: FOV analysis, setup one and two. ....	44
Figure 23: FOV analysis, setup 2.....	46
Figure 24: Top view illustration of positions in the SBW (size not to scale).....	47
Figure 25: Augmented reality on the shipside. ....	48

Figure 26: The most promising consoles so far. ....52

Figure 27: Future concept proposition.....53



## List of tables

Table 1: Characteristics and placement identification and evaluation of the consoles.....50

Table 2: Pros and cons of console prototypes.....51

---

## Abbreviations and definitions

SBW	Ship bridge wing
FOV	Field of view
ECDIS	Electronic chart display
DT	Design thinking
KM	Kongsberg Maritime
AR	Augmented reality
VHF	Very High Frequency radio Communication with other vessels, dock crew, etc.
UHF	Ultra-High Frequency radio Communication with on-board crew
SMSC	Ship Modelling & simulation Centre AS, located in Trondheim
Conning display	Overview display containing heading, velocity, rate of turn, wind, propeller/thruster power and direction and rudder angle and other vital navigational information.
Captain	The ships top commander.
Mates	Different officer rankings below captain. Range from First Mate to Third Mate. (various names exist)
Lookout	Person observing surroundings during sailing.

# 1 The potential of the ship bridge wing

## 1.1 The challenge

The initial challenge from Kongsberg Maritime was very open, and called “Next Generation Ship Bridge”. As the ship bridge in total is a huge and complex environment, discussions led to the more specified challenge of rethinking and further developing the ship bridge wing. Four central focus areas developed: Rethink the console design; rethink the bridge wing design; Increasing the field of view (FOV); and information feedback to the user. In this report, the way of working and the ideas provided are presented in detail, through several prototypes, analysis, tests and visits to ships. In total, we have been to three ship visits whereas one in action, a ship simulator, in contact with education personnel from “Høgskolen i Ålesund” and consulted with an interaction designer. We have made a testing environment, built a low-level ship simulator, conducted two field of view analyses, built some 30-40 physical prototypes, and performed countless tests of prototypes, acting as a captain for several hours in total.

In this report, we will first present some context and background to the subject, followed by theory describing our methods. Then follows a summary of our visits, our findings on relevant information technology and an introduction to our four main console principles, floor-, ceiling-, body-, and rail consoles, as well as the presentation of several ideas and selected prototypes. Finally, we summarize and discuss our findings and knowledge, and present suggestions to further work along with a conclusion.

## 1.2 Motivation

The shipping industry is an old, proud and well renowned industry, especially as a part of Norwegian history. It spans from 5000 years BC, the oldest known drawing of a vessel with sails (Carter, 2006), until today, when the world’s merchant shipping carries a substantial amount of all international trade. Another considerable amount of shipping is in passenger transport, handling close to 400 million in 2012 in EU countries alone (Eurostat, 2014).

There are many drawbacks with the different aspects of bridge wings as of today (autumn 2015), and the opportunities for improvement are many. The extent of the shipping industry allows for a considerable potential, and when presented with the opportunity and challenge of this project, we saw it as a chance to utilize our own interests in building prototypes, and to offer the shipping industry a perspective on the challenge of product development.

Further, this challenge was not to be restricted by existing regulations, so these are therefore neglected, and our ideas was open to any direction.



*Figure 1: Color Magic with highlighted ship bridge wing*

### 1.3 Bridge wing design

Bridge wings of today are custom designed to fit their ship. Many large cargo vessels only have outboard bridge wings without consoles, while passenger ships such as cruise ships with the bridge in the front of the ship have inboard bridge wings. This works as an extension of the main bridge, from which the ship can be manoeuvred, see Figure 1. Some ships, for instance certain icebreaker ships, even have all of their main bridge equipment placed out on the bridge wing. This creates a need for a larger sized bridge wing.

Even though they are different, all bridge wings have one main purpose in common: maximizing the view over the sides of the ship. However, although bridge wings are custom designed to fit their own ship, they often tend to resemble each other in many ways and bear many of the same weaknesses: Windows do not reach all the way down to the floor, floor windows are, if present, too small or poorly placed and structural beams creates blind zones. All of these issues compromises the FOV.

### 1.4 Console design

Consoles on bridge wings are like the bridge wings themselves, designed and arranged after precise rules and the customer's requirements. The user is rarely included in the decision, and console suppliers are often bound by regulations that creates limitations to the console

design. As a result, consoles often end up taking up a big part of the space on the bridge wing, reducing the ship officers' freedom of movement, see Figure 2. Many of today's consoles are also completely fixed, giving no possibilities for personal adjustments. The person in control of the ship will have to make do with the position of the console as is, and must therefore stand on roughly the same spot the entire time the ship is being manoeuvred from the bridge wing, even though the wanted view might be blocked from this position. Other issues involve the information feedback, such as the conning display and ECDIS, sometimes displayed on screens that are difficult to read due to light conditions. The console panel is usually filled with a large number of buttons that for most cases are not being used at all during a bridge wing operation.



*Figure 2: A traditional ship bridge wing console.*

## 1.5 Regulations

The highly conservative shipping industry is directed by strict regulations and laws based on experience, thus working as a drawback while innovating parts of the industry. It proves hard to come up with new solutions that do not resemble the old ones. In regulations from certification companies, some of the specifications states the size of consoles, and modules in millimetres, thus leading to longer transition times between technology upgrades. Therefore, such regulations are ignored during this project, to make for a more open design space.

## 2 Early phase, human-centred approach

### 2.1 The Fuzzy Front-End Phase

When excluding the regulations from the equation, the potential of the bridge wing is vast. To explore this potential, the project started from scratch, at the very beginning of, in particular, new product development. This is often referred to as the *fuzzy front-end* (FFE) phase, a term made popular by Smith and Reinertsen (1991) and defined as the period of evolving an idea from an opportunity, to the point when the product is defined and ready for development and organizational absorption (Kim & Wilemon, 2002; Reid & De Brentani, 2004). This includes idea- and concept generation, formulation and assessment (Moenaert, De Meyer, Souder, & Deschoolmeester, 1995; Murphy & Kumar, 1997), as well as identifying opportunities, formulate product strategy and executive reviews (Khurana & Rosenthal, 1997).

The FFE is an ambiguous phase in new product development (Steinert & Leifer, 2012), with a lot of potential (Reinertsen, 1999), but can be hard to truly leverage and understand according to Kim and Wilemon (2002). It consists of a number of divergent and convergent iterations. Common philosophies and processes to manage the steps of the FFE are Design Thinking (DT) (Brown, 2008), and Wayfaring (Gerstenberg, Sjöman, Reime, Abrahamsson, & Steinert, 2015; Leifer & Steinert, 2014; Steinert & Leifer, 2012).

### 2.2 Design thinking philosophy

According to Tim Brown, Design Thinking is:

*"... a methodology that imbues the full spectrum of innovation activities with a human-centered design ethos. By this I [Brown] mean that innovation is powered by a thorough understanding, through direct observation, of what people want and need in their lives and what they like or dislike about the way particular products are made, packaged, marketed, sold, and supported."* (Brown, 2008, p. 1).

This methodology is applicable to almost any circumstance where humans are involved. It encourages gathering of as much knowledge as possible through multidisciplinary teams,

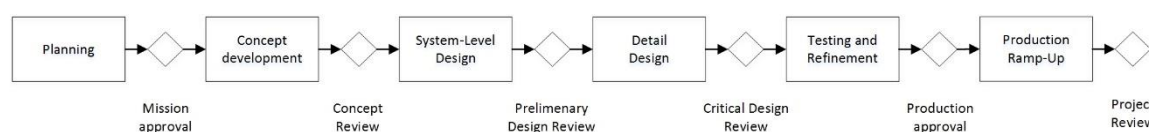

Figure 3: Generic stage-gate model

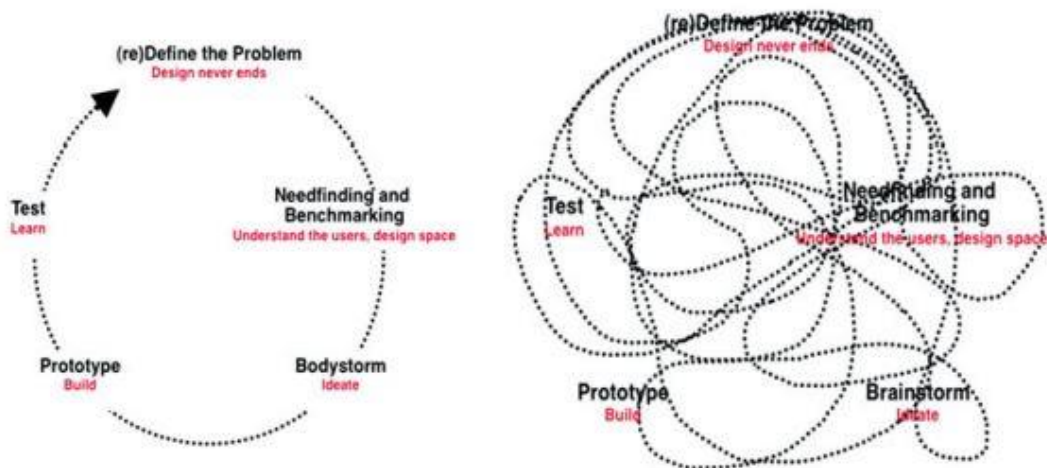

Figure 4: Design thinking model.

applying multiple points-of-view concurrently (Leifer & Steinert, 2014). Where models that are more traditional such as the stage-gate model by Ulrich and Eppinger (2012) illustrated in Figure 3, goes through predefined steps in a linear way, DT consists of several “spaces” or “states of mind” one loops through several times as ideas evolve and is redefined according to Brown (2008). He defines these spaces as “Inspiration”, “Ideation” and “implementation”. In the inspiration space, you explore problems and/or opportunities, and the ideation is when you diverge and generate ideas to eventually test. The implementation is when you bring the project out to the market. Brown further states that a design thinker is not necessarily a designer, although the name might be confusing. However, to fully appreciate the philosophy of DT, one should enter certain characteristics – the ability to empathize with the user, or stakeholder, understanding their needs, activities and desires; an experimental mind, asking questions and exploring possibilities; and a collaborative working environment, including multiple disciplines (Brown, 2008). The design thinking mentality is embraced at IDEO, an internationally reconditioned design firm. Meinel and Leifer (2010) has depicted the process more elaborate, consisting of five major steps, as presented in Figure 4, from "Design Thinking Research" by Meinel and Leifer (2010, p. xiv). This figure shows a common visualization of the DT process to the left, and a more realistic DT approach to the right.

### 2.3 Wayfaring as a product development process

Wayfaring, visualized in Figure 5 by Gerstenberg et al. (2015, p. 413), as a product development process first described by Steinert and Leifer (2012) in the Hunter-Gatherer Model, and later in detail by (Gerstenberg et al., 2015), works on a time basis, rather than

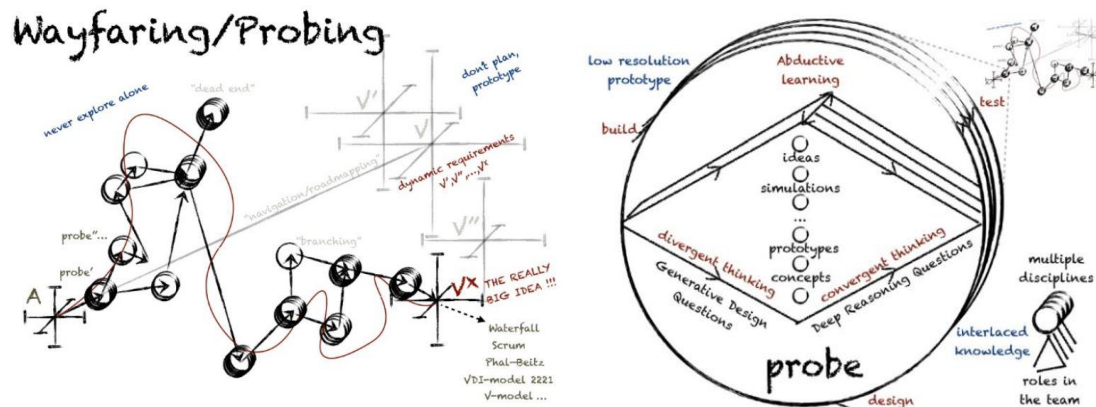

Figure 5: Wayfaring model, and probing activity.

an output or milestone basis, applied in the early pre-requirement stages. The model depicts parallel processes in multiple directions, and even dead ends. Wayfaring in front-end concept generation approaches the problem through probing, see Figure 5 by Gerstenberg et al. (2015, p. 414). Probing is the act of iteratively designing, building and testing ideas through divergent and convergent activities. Prototypes works as representations of the ideas, and conveys its intentions, allowing for fast learning through interaction and visualization. In terms, these learnings will help define the requirements of the concept(s) developed to undertake previously unknown solutions. As no one can accurately define what is yet unknown, in particular in complex situations (Snowden & Boone, 2007), a Wayfaring approach has great potential when dealing with such complex challenges according to Gerstenberg et al. (2015), which is often related to radical innovations and new product development.

## 2.4 Prototypes

In Wayfaring and Design Thinking, prototypes are invaluable. They convey the developers' or designers' ideas and solutions both inside teams, and to users, and helps understand the situation and user perspective. A good prototype is one that communicates the desired design idea (a function, feature or any other quality) and its characteristics, in an efficient way, so that it may serve as a foundation for discussion, testing, evaluation and learning (Lim, Stolterman, & Tenenberg, 2008). A broader more ambiguous definition is proposed by Houde and Hill (1997), saying that no matter the medium, a prototype is any form of portrayal of an idea. It may be of low or high resolution, demonstrate a critical function, an alpha- or beta prototype, an environmental model, in full-scale or small-scale, a functional prototype or as a layout proposal or CAD-model etc. and the possibilities are endless, see



illustrations in Figure 6. This figure also shows a low-resolution prototype, and one of higher resolution.

What kind of prototype you make depends on where you are in the process. Early on, the models are often simple, and keep functions separated, while they later become gradually more complex, implementing functions and attributes.



*Figure 6: Different resolution prototypes.*

The prototype definitions from both Lim et al. (2008) and Houde and Hill (1997) allows for a prototype to be more than a physical manifestation. As Buchenau and Suri (2000) explains, it may also be to experience the activities imposed to or by the product or service at hand, what they call “Experience Prototyping”. This is to gain first-hand encounters and knowledge, and may or may not include a physical prototype or product.

The act of probing and fast learning through iterations in the early stages of development implies fast prototyping to test particular ideas (Leifer & Steinert, 2014), thus resulting in low resolution prototypes. The ability to learn from such rapid models is the driver of the Wayfaring process according to Leifer and Steinert, and the iterations increases the likelihood of a good result (Dow, Heddlestone, & Klemmer, 2009).

### 3 Application of theory

The project described in this report is a result of the challenge to rethink and further develop the ship bridge wing, given by Kongsberg Maritime. In order to present something new that is unaffected by previous models and existing regulations, the project needed to start from scratch. Thus, requiring us to engage in the fuzzy front-end (FFE) phase of new product development, including empathizing, idea- and concept generation, with a basis in the previously described theory.

#### 3.1 Mind-set and process

In this pre-master project, we do not strictly follow a development model or structure, but are inspired by two models; Design Thinking and Wayfaring, explained in the previous chapter. DT, which revolves around the user(s) and Wayfaring which focuses on following hunches and nuggets, thought us to focus on: empathy, understanding the user perspective; defining the problems as they arise; prototyping and testing ideas; and learning through iteration cycles. To maximize the outcome and precision of key decisions along the way, one should involve the user regularly. However, as will be explained in the discussion, it proved difficult to engage in this regular dialog with the user.

We focused on empathizing, understanding the situation for the users today, trying to see what impacts our ideas and prototypes had on their activities. We performed four visits, described in chapter 5.1, to ships, and other stakeholders to gain such an understanding. We even joined a captain and First Mate on the bridge as they docked and undocked in Kiel and Oslo respectively.

This knowledge was applied to the process of Wayfaring. Gerstenberg et al. and Steinert & Leifer shows through the model in Figure 5, the need for an open and continuously hungry mind in order to come up with the next big idea. This mind-set is utilized in several design directions, both in series and in parallel, leading to constant learnings and discoveries. The knowledge from each step builds upon each other and adopts new information from different disciplines along the way. Through this project, several rounds of such iteration and learning cycles, aided by prototypes, has been conducted to improve the outcome, an effect confirmed by the experiment conducted by Dow et al. (2009).

Throughout this pre-master project, there has been four focus areas (see Appendix A – Assignment Text), which all connects to the ship bridge wing. This resulted in parallel processes, jumping back and forth between the different focus areas depending on our

current progress. As FOV is an important criterion for the SBW design, they are merged in the same engineering design process, while the information feedback, and console design were separated.

### 3.2 Prototyping and testing

As mentioned in the previous section, prototypes, which we in total made above 30 of, plays an important role during this development process. This includes rapid small-scale models, multi-resolution prototypes, ship simulators, full-scale models, CAD models and others, made out of different materials with diverse tools. We have especially used low-resolution prototypes, typically simple cardboard models, to rapidly test and evaluate ideas. The evaluation then led to the decision to keep on going, or discard the concepts or some of its attributes, as one of the core ideas in Wayfaring. However, an important notice, which we ran into ourselves, is that prototyping without clear intentions might be a waste of time.

Further, to increase our understanding of the activities on the SBW and how they may be affected by our ideas, concepts and prototypes, we utilized experience prototyping (Buchenau & Suri, 2000). In practice, we built a SBW environment and a low-resolution simulator (see chapter 7) to enhance the feeling of interacting with a ship during testing and evaluating design ideas.

### 3.3 Process evaluation

During this pre-master project consisting of rethinking and further developing the ship bridge wing, we have encountered everything from moments of high enthusiasm and eye opening experiences to ambiguous meltdowns and wall staring as a part of our journey. We found that new product development and innovation has several difficulties, and the ambiguity it conveys might be both good and bad at times. However, the uncertainty and openness of the task also implies a lot of potential, as it opens up for solutions and ideas in numerous directions.

Along the way, tools from the methods described in chapter 2 have helped us to structure and follow through with our challenge. Prototypes, in particular, has been central, as both authors embrace every opportunity to build stuff and get their hands dirty. Wayfaring as a mind-set when conducting new product development has proved efficient during this project, along with a practical way of dealing with challenges along the way. As mentioned, this project is not directed by strictly following any process, but the iterative application of different mentalities, made our ideas evolve towards an outcome defined along the way.

## 4 Bridge wing preconditions

### 4.1 Definitions

As a basis for the project described in this report, the following definition of a ship bridge wing will be used:

*A ship bridge wing is an extension of the ship bridge, the “pilothouse” of a vessel, reaching out towards or slightly beyond both sides of the ship. It allows bridge personnel, such as captains and officers, to increase their overview of the shipside while manoeuvring in narrow waterways and/or docking.*

The SBW is, while being used, commonly populated with two persons from the bridge crew: one steering the ship; and one controlling communication, on-shore and on-board activities. In this report, we define them as following:

Captain	The person steering or manoeuvring the ship
First Mate	The person handling communication and other ship tasks

It is important to notice that this is not a general definition of the norm at sea, but strictly limited to this report, in order to ease the descriptions and discussions in the following chapters. As chapter 5 elaborates, different crews have their own routines as to whom are in control of what.

### 4.2 Limitations

Through insights from the meetings described in chapter 5, we established a set of limitations, or criteria that would define the rest of our work. These were necessary to define our scope, or design space because of the limitless amount of possibilities the numerous ship designs create. Limitations and prerequisites taken into account is listed below:

- Focus on mid- to large size vessels
- Two persons on the ship bridge wing, as described in the previous section
- No regulations or certifications considered
- Evaluation and discussion mostly based on cruise ships, such as M/S Color Magic

### 4.3 Stakeholder analysis

Figure 7 shows an overview of the various stakeholders and their interests for SBWs. As shown, the user is not directly linked to the designers/developers, but only through the shipyard and the owner. There might be however, that the developers and users

communicate while the ship is in for repairs or updates. Further, the figure shows that the bridge crew actually does some quick fixes to the bridge by their own to accommodate for poor or missing solutions.

As mentioned, this project focuses on the user represented by “BW Personnel” in the figure and somewhat on the bridge wing (highlighted in grey), not on satisfying existing regulations and owners, which is often the case today. By increasing the value for the direct user, we decrease the problems and need for constant updates due to bad designs, as well as the crew’s workarounds and adaptations. The decrease in changes and upgrades also pays out to the owner, as their ships need less time and visits to the shipyard and technicians. In addition, more satisfied users lead to more satisfied owners, which in turn might result in more sales and better relations between developers/manufacturers and ship owners (buyers). Dotted lines in the figure, originating from the “BW personnel”, mark these value transactions. The discussions with some of the stakeholders are presented in chapter 5.1.

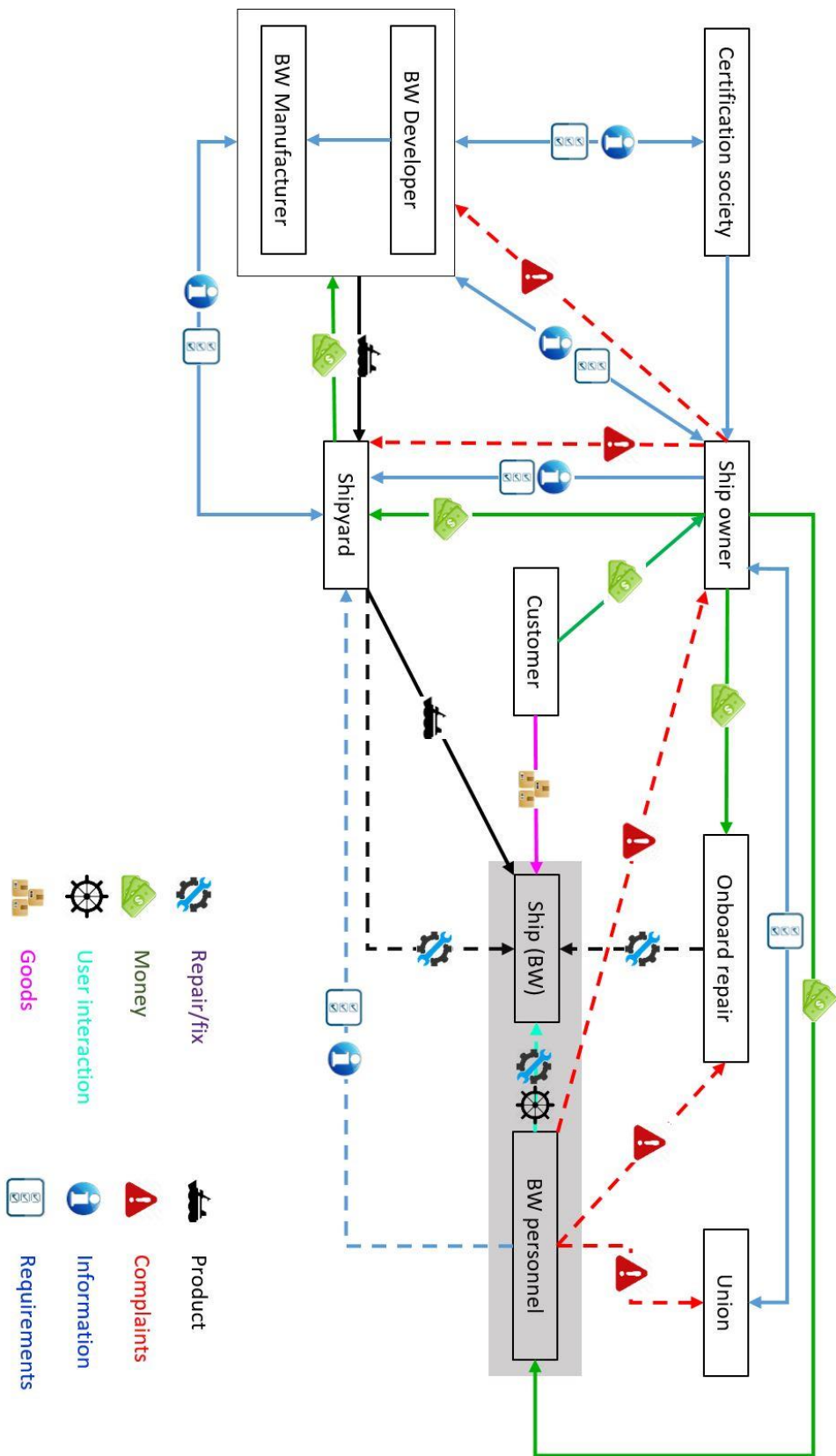

Figure 7: Stakeholder and value chain map.

## 5 Exploring today's Ship Bridge

### 5.1 Visits

Several visits made to ships during the entire project helped to increase the understanding of the bridge wing, and to kick-start the empathizing. The following subsections summarize the visits.

#### 5.1.1 Color Line 1

- **Visited:** Color Line, bridge of M/S Color Magic at Hjortnes dock in Oslo.
- **People spoken to:** Young mate.
- **Discoveries**
  - They use approximately a quarter of available buttons and controllers on the panel during docking.
  - The captain was in charge of communications and was overseeing the operation, while First Mate steered the ship.
  - During darkness: the one not manoeuvring the ship controls lights.
  - Natural hierarchic, but friendly relations.
  - No systems stopping the user from operating engines against each other.
  - Information screens are hard to see because of bright ambient light
  - Self made and fitted cupholders on the rails.
  - A small line is drawn on a window with a marker. This is used as a reference to align with outside references to know where to stop the ship.

#### 5.1.2 Color Line 2

- **Visited:** Bridge of M/S Color Magic during undocking in Oslo and docking in Kiel.
- **People spoken to:** Captain and First Mate (both middle-aged).
- **Discoveries**
  - Relaxed atmosphere. The officers are confident and experienced on their tasks.
  - Highly unusual event occurred: Lost power on main engine no. 3 causing loss of 2/4 bow thrusters and 2/2 stern thrusters. The captain is puzzled for

a few seconds, and then decides to switch of malfunctioning engines on the console and fix the problem later when back on the main bridge.

- First Mate operates the controllers behind him while undocking, see Figure 8.
- Uses autopilot most of the time during the voyage.
- The ship was manoeuvred into the bay of Kiel manually.
- Rudder is operated by the lookout on a separate console on commands from the First Mate.
- Other German vessels in the bay insists on speaking German instead of English which is the international nautical language, forcing the captain to speak German over the VHF.
- Command over the ship is switched to the bridge wing before turning the ship 180 degrees to back into the dock.
- Powerful side wind makes it more difficult to control the ship because the ship geometry makes the wind turn the ship.
- Lost momentum backwards into the dock because the First Mate lost his concentration for a brief moment. This resulted in higher fuel consumption.
- CCTV mounted at the stern of the ship is used to see when to stop the ship. It is placed such that the end of the ship is out of visual range. They must rely on lines drawn on the dock.

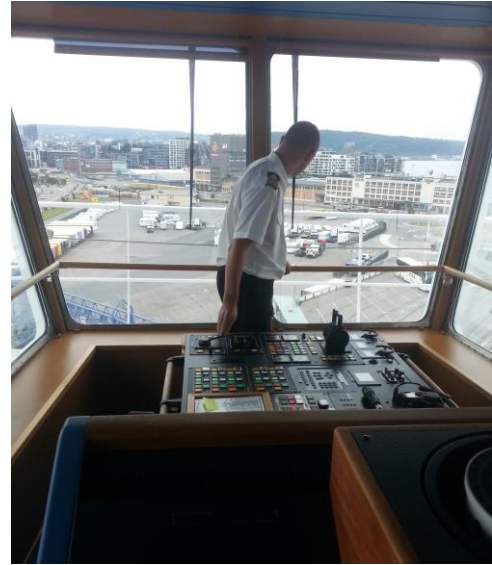

*Figure 8: First Mate in action at SBW*

### 5.1.3 SMSC, Ship Simulator

- **Visited:** Ship Modelling and Simulation Centre (SMSC) in Trondheim. A training facility with several full size ship simulators.
- **People spoken to:** A simulator technician and a ship navigation instructor.
- **What was seen and done:**



- We were shown their different simulators and got to try their largest one, where we were given a task consisting of docking a mid-sized oil tanker.
- There was no console on the bridge wing. To dock the ship, one stood on the bridge wing giving information about the distance from the dock, while the other would steer the ship «blind» from the main bridge relying on commands and the conning display.
- **Discoveries**
  - We learned that their consoles were mostly fixed and used for any kind of setup with different ships.
  - It was difficult to compensate for the delay in the ships movement caused by the ships inertia.
  - We were easily hung up with the conning display to get the ship's heading right, losing focus on the outside. It was hard to keep the heading steady.
  - The lack of depth perception on the screen was also challenging.
  - The bridge was dark to make the projections more visible, thus making it hard to see the controllers.
  - Bridge wings and consoles are in general custom made to fit their specific ship.
  - Ships usually do not have supporting systems to aid the captain during docking.
  - Almost no weather conditions stop ship crews from docking. During heavy fog or darkness, the captain rely on radar and communication with dock crew.
  - SMSC trains captains and mates from around the world, providing simulators and instructors. The most common reasons for failing an exam are:
    - Wrong procedures according to regulations
    - Misunderstanding instructions/orders
    - Overuse of controllers
    - Misjudgements during critical situations

#### 5.1.4 Hurtigruten

- **Visited:** Ship bridge of M/S Polarlys at the dock in Trondheim.
- **People spoken to:** The captain (older male).

- **Discoveries**

- The captain steers the ship from the SBW while First Mate handles communication, hatches, alarms, etc.
- The First Mate is stationed at the opposite bridge wing to keep an eye at the other shipside. When close to the dock, the First Mate moves to the main bridge, or to the captain.
- The captain was satisfied with the status quo on the console's placement, although the console panel layout was poor.
- Long distance between controllers for rudder and thruster.
- The Conning display was not faced towards the user's position
- Poor contrast on screens. The crew made a quick fix with tinted foil covering the screens.
- All buttons light up with equal strength
- A window pillar was placed right behind the captain's position blocking the FOV.
- Windows reached only half way down to the floor.
- A problem with full covering windows are poor isolation. This is solved with heated windows on some ships. This function makes it too warm when turned on and too cold when turned off.
- A small window in the floor, with poor position gave minimal FOV increase.



Figure 9: Small floor window

## 5.2 Pain Points at the Ship Bridge Wing

From our interviews, visits, trips and navigation trials we found several pain points and rooms for improvement.

- Console
  - Poor positioning of controllers in relation to each other
  - Large console housing
  - A lot of redundant buttons
  - Awkward steering position for user
- SBW
  - Many blind spots
  - Tight around the console
    - Mainly because of a large console
  - Relatively small windows
  - Large window frames
- FOV
  - Distracted by window frames
  - Small, low-resolution CCTV cameras show hidden surroundings
  - Varying light conditions
    - At times making it difficult to see information screens
- General
  - A lot of self-made quick fixes
    - Covering up bright screens
    - Manual distance markers
    - Cup holders bought and mounted by crew
  - Little information of ships surroundings
    - Distance to objects/dock
    - What happens on the other side of the ship?

These pain points compose the foundation of which areas to focus on during the development of the concepts, as described in the following chapters. The majority of time and effort is concentrated on the improvement of the console, but the project started at attacking the pain points concerning information feedback by searching for technologies involving this, as described in the next chapter.

## 6 Information Technology

### 6.1 Initial Technology Analysis

A search for different technologies to improve the user experience at SBWs were conducted. The initial method was to look at different technologies, both in use today and future ones, from environments that are comparable or resembles that of a SBW. We mainly searched for other technologies among different transport segments. This research led to an overview over following industries:

- Automotive industry
- Aviation
- Air traffic control
- Railroad
- Shipping
- Construction cranes
- Touch screen technology

Significant findings from the industries was different types of information feedback applicable for SBWs, mostly from the aviation and automotive industry. What was found most interesting was different ways of using heads-up display on the windows of the SBW to give the officers practical information overview. Another key finding was tactile technology implemented in touchscreens. One could replace many of the buttons not frequently used, for instance by microfluidic touchscreens, making the relevant buttons “pop up” when needed. However, this topic is only briefly covered in this report, as the main focus of this project has been the user’s working position in the SBW.

### 6.2 Testing Technologies

At *NorShipping*<sup>1</sup>, we learned about several companies that are developing products to improve feedback from bridge consoles and controllers. One of the innovations that are ongoing by companies are haptic feedback in power controllers. However, the entire portfolio of presented technologies at *NorShipping* followed the industry’s strict regulations, which is not a demand for the concepts in this report. Instead, tests were performed based on the technologies mentioned in chapter 6.1, that we could not find on a ship today. The purpose was to assess to which degree the different technologies would improve feedback and information presented to the user.

---

<sup>1</sup> An annually, well-established trade fair in the shipping industry. <http://messe.no/en/nor-shipping/>

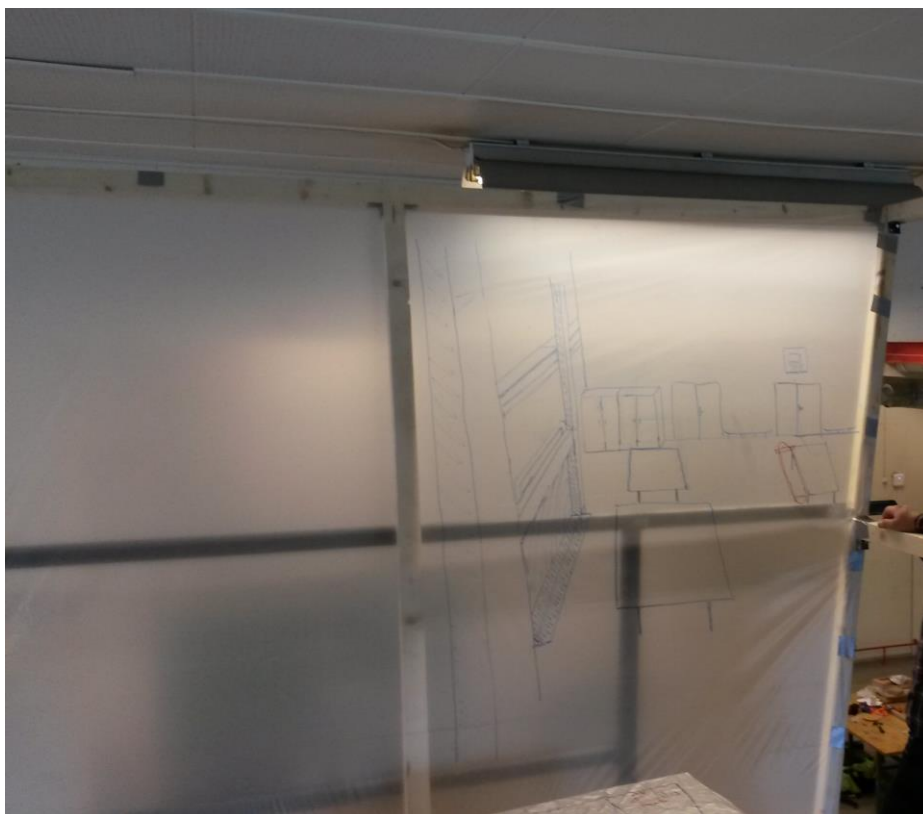

Figure 10: Augmented reality prototype.

### 6.2.1 Augmented Reality and Head-Up Display

The first test simulating augmented reality was performed at a mock-up SBW (described in detail in chapter 7). After a round of ideation, the setup was rapidly prototyped using the materials that was available at the time being. A semi-transparent plastic foil, drawn across the front of the SBW, represented the windows. The contours of major objects across the workshop floor, in this case acting as obstacles at sea, was highlighted for the user by drawing them on the plastic sheet, see Figure 10. This exposed the weakness of using head-up display on the windows for this purpose, which could only visualize the correct image from a stationary point of view. For the contours to outline the present objects correctly from any position the user might stand, he would have to wear spectacles with augmented reality technology, or the projection would need altering depending on the user's position. Drascic and Milgram (1996) elaborates these issues (among others) and calls them: *viewpoint dependency mismatch*, the alignment between the point-of-view and the projection; *interposition failure*, the fact that far objects in real world cannot block near objects; and *accommodation mismatch*, that objects interacting with the real world are projected on a screen, and not on the physical object. This technology has great potential, but is put on hold in this project because of the difficulties and need for high precision.

### 6.2.2 Panel Controllers

As our visits to different ships showed, most of the interactions the user have with the ship during SBW operations, happens through the console panel, particularly through

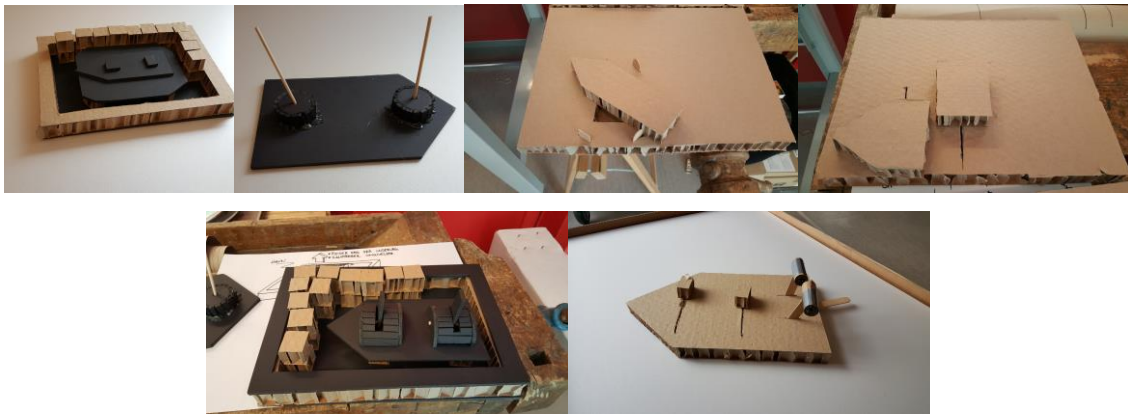

Figure 11: Various prototypes of controllers

navigational controllers. During the period of empathizing, it was discovered that there might be potential in improving the interactions between the user and controllers, including feedback from the ship and its movement. This resulted in a few ideas that were rapidly prototyped; some involving the technologies discovered, see Figure 11.

A common concept for most of the prototypes was having a panel or controller shaped as a ship. The idea was that this would make it easier to eliminate confusion caused by the orientation of the console relative to the ship. Two of the panel prototypes were shaped as a ship with controllers placed on the panel relative to where their controlled actuators are located on the ship itself. Two other prototypes represents a panel in the form of a detailed ECDIS with a single ship shaped controller with the contours of the harbour being elevated on the panel using microfluidic technology or micro actuators.

## 7 Console Development

During the period of empathizing, we found that many of the controllers, buttons, screens etc. is not frequently used, maybe not at all by the person actually steering the ship. In addition, most of the larger ships (on which we are focusing) have two officers present at all time while manoeuvring from the bridge wing, as described in chapter 4. These observations led to some insights defining the scope of the console designs.

- The captain only steers the ship through bow/stern thrusters, rudders, main engines and/or azimuth thruster(s).
  - **Insight: Make smaller, less cluttered steering-focused console**
- The First Mate operates communication, alarms and all other tasks on the bridge.
  - **Insight: Separate a lot of the features from the “drivers console”**
- Should not be a physical or visual obstacle.
  - **Insight: minimize the console’s impact on the FOV**

We chose to focus mostly on the design of the module, rather than the layout of the controllers during this phase. Most of our console suggestions therefore focuses on the structure and the shape of the consoles, and our goal is to optimize the console body. However, we have utilized some simple visual controllers, both physical and drawings, to symbolize the control panel.

In order to test and evaluate the console concepts, we constructed a SBW environment consisting of a frame in the shape of a bridge wing, size-equivalent to that of a mid-size ship. The construction, built approximately 5 meters above ground upon a shipping container, had an overview of the workshop floor. Through several rounds of ideating around possible ways to make a console on a SBW, we ended up prototyping and testing four main principles: floor-, ceiling-, rail- and body console. The models, trials and errors, built upon each other through an iterative process, continuously highlighting new critical functions and criterions of the consoles. The following sections describes these iterations.

### 7.1 Simulator

During ideation, we found that it was desirable to have a way of simulating the docking experience, not fully, but at the very least as a way of differentiating between the usability of the different consoles. Since the testing environment was fixed to a shipping container, the best



Figure 12: Simulator panel

option was to simulate the docking through moving the “dock” itself on the workshop floor, represented by a large cardboard plate. Inverted motions ensured a feeling of docking a vessel, and two thruster handles controlled the speed of the motions. The forward and backwards motion was excluded for simplicity. The simulator panel is shown in Figure 12.

## 7.2 Ceiling Console

### 7.2.1 First Version – C01

Our first prototype of a ceiling based console, was made by foamboard, and was also demonstrated as a rail console and a body console (see chapter 7.4 and 7.5). The foamboard mock-up tied to the ceiling using a rope, demonstrated the ability to freely move the console around, letting the captain choose his position based on personal preferences and needs.

**Learnings: Needs further development**

**Positive outcomes: Free movement**

### 7.2.2 Second Version – C02

This originated from a workshop at TrollLabs with KM. Some modifications were needed to make it fit to the SBW model that we made at the workshop. A frame was built to demonstrate free movement in the horizontal plane. The frame was reused for all the following ceiling prototypes. This prototype also demonstrated height adjustment, simply by lifting the console panel up its cardboard column. It further showed that a column holding the console from the ceiling, as seen in Figure 13, could be very disturbing for the captain’s FOV. Even held in such a way that the view was not obstructed, the mere presence of the column close to the users head can be too distracting.

**Learnings: Column distracting FOV**

**Positive outcomes: Free movement**



Figure 13: Second ceiling console.



### 7.2.3 Third and Fourth Version – C03 & C04

The next iterations of ceiling console prototypes was built with stiffer columns. The third version shown in Figure 14, had a fixed column going down with an L-shape and had three degrees of freedom; translation in the horizontal plane and rotation about its vertical axis. The fourth version had three more joints, taking care of height adjustment and rotation of the console panel.

These versions was built with focus on solving the issue with an interfering column. They were therefore made such that the vertical part of the column reached down behind the user, connected to the panel through other beams with either fixed (C03) or rotational joints (C04). In this way, the column itself did not interfere with the immediate surroundings of the user, which proved to be favourable. What we also learned with C04 was that two joints on the column is redundant. One joint on the column in addition to a pivoting panel should be sufficient. The ceiling concept was nevertheless abandoned because other prototypes showed more potential and because of the challenges of supporting large objects from above.

**Learnings: Moment in arm. Somewhat obstructed FOV because of panel.**

**Positive outcomes: Ergonomic working position.**

## 7.3 Floor Console

### 7.3.1 First and Second Version – F01 & F02

The very first floor console prototype consisted only of a seat from an office chair, with a piece of illustrative paper on top. The second floor console, as can be seen in Figure 15, was made of cardboard, and included the ability to adjust the height, as well as some illustrative controllers. Both the first and second floor console prototype also made it possible to test different positions of a possible floor console.

The prototypes led to the realization that the positioning and shape of the console may lead to an obstruction for

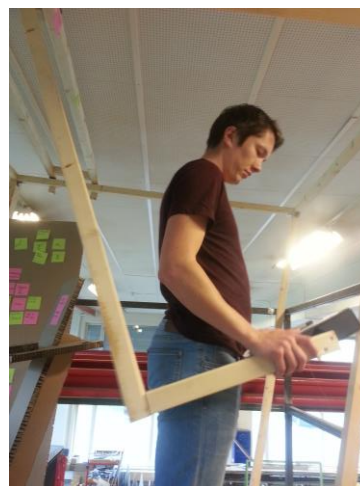

Figure 14: Ceiling console, version three

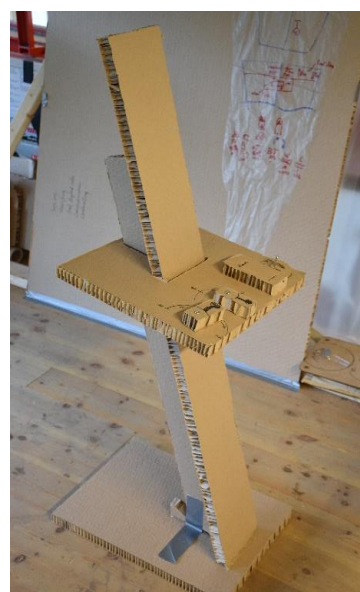

Figure 15: Floor console, version two.

the user's movement of legs and arms. The large, angled stand from version two, as well as the large foundation of the office chair hinders the user's legs to move freely. The console should rather be built to increase the space underneath the top panel in addition to feature a simple locking mechanism for height regulation. Further, when positioned in front of the user, the construction should occupy as little of the FOV as possible to not disturb the operation.

As mentioned, this smaller floor console's ability to be moved around proved that such a design, even as a fixed one, gave the user many possibilities in terms of working positions as well as freeing up a lot of space in the SBW.

**Learnings: Decrease size of base. Rotation of console might lead to confusion.**

**Positive outcomes: Flexible working positions.**

### 7.3.2 Third Version – F03

This floor console prototype included the ability to adjust the angle of the leg and control panel, see Figure 16. Although height adjustment is not included directly, tilting the whole stand will adjust the height to some extent. We wanted to test the feature of a console mounted at the lower part of the outwards facing window, including the ability to move it along the edge of the bridge wing.

This model led to the discovery that the panel, though a lot smaller than in today's ships, might actually disturb the captain's FOV when placed in front. Further, it also proved that a full range of tilt of the console panel, as well as the whole column proved to be superfluous. Testing showed that horizontal arm movements are less tiring than vertical when operating the console.

**Learnings: Full tilt range unnecessary. Panel disturbing FOV.**

**Positive outcomes: Split the console in two.**



Figure 16: Third version floor console

### 7.3.3 Fourth Version – F04

As F03 showed a tendency to disturb the FOV, a new design was necessary. The console was split into two parts, see Figure 17, with the user in the middle. This allowed for a less compromised FOV, as well as an open plan solution. The thought behind it is to utilize both hands during navigation, splitting critical functions to each hand. This permits the option of splitting front/back controllers or thrusters and engines between the two control panels. However, a closer look into the effects of multitasking might be necessary in order to evaluate whether it affects the captain negatively.

This model also enhanced the differences in preferred console height between different users. This might be because it offers the option of resting ones arms and/or elbows on the console while navigating. Further, by keeping the two consoles free from placement restrictions, it was found preferable to make the width between the modules adjustable, depending on personal preferences and size. The advantages of letting the user face outwards without having to operate a console behind him, and giving a clear FOV gave reasons to further develop this design.

**Learnings: Width adjustment preferable. Reduce base size.**

**Positive outcomes: Free FOV. Height adjustment. Flexible working positions.**



*Figure 17: Fourth version floor console*

### 7.3.4 Fifth Version – F05

The first three prototypes of floor consoles had different designs that were all discarded due to various reasons. The fifth version builds upon the previous one, F04, but now with only one leg and with the top plate wrapped around the back of the user as shown in Figure 18. The console as a whole takes up more space than previous floor consoles, but by wrapping the console around the user, it gives him/her an option to use it as a “stand-up-chair”, and get physical support during navigation.

The prototype further includes width adjustment and tilt, both at the top plate, and in the footrest, along with a slight horizontal rotation of the control panels. The ability to tilt this console was found superfluous, though it gave this exact model a rough height adjustment capability. The control panel rotation proved not so important.

This was still a rough prototype, but the design was found interesting enough to test a more elaborate console.

**Learnings: Tilt not necessary.**

**Positive outcomes: Width adjustment. Free FOV.**

### 7.3.5 Sixth Version – F06

This is a more robust and elaborate version of F05, and is shown in Figure 19. This does not have a tilt function, but instead a telescopic function that provides height adjustment. It gives the opportunity to lean one’s arms on the console panel, or operate the controls with stretched arms if this is preferred. This version is also width-adjustable and includes a locking mechanism. It is released by pulling handles underneath the panel.

Among observations done during testing was that the panel sides could steal important parts of the FOV when the console is in an elevated position with the user leaning against the back of the console. We also discovered that the angle that the



Figure 18: Floor console, version five

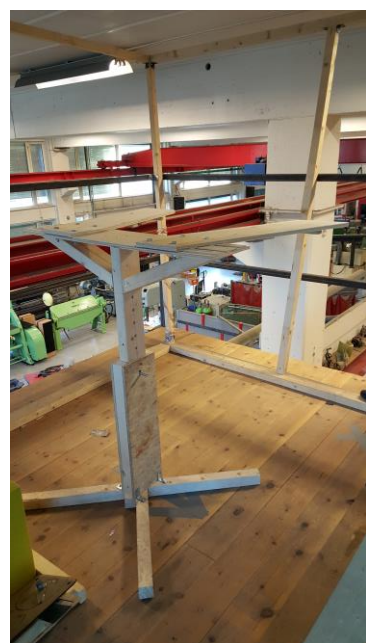

Figure 19: Version six of the floor console

panel sides was given could be undesirable compared to having the sides point straight forward. This spoke towards making the angle adjustable to some degree, thus also improve the action of stepping in or out of the console. The last argument is however also a big weakness with this type of console. It will inevitably occupy a substantial part of the floor area, and the user must go around to step into the console. This action can be simplified by splitting the console in two parts with each side having its own base, allowing the user to step directly into the working position.

**Learnings: Split console completely in two. Continuous adjustments.**

**Positive outcomes: Width adjustments with lock. Height adjustment.**

#### 7.4 Rail Console – R01 & R02

The prototype mentioned in 7.2.1 was reused to rapidly test the concept of a rail-mounted console. The intention was to bring the console in front of the user, thus making it easier to focus on both the controllers and working perimeter outside the ship. A second version made to fit in the mock-up SBW, see Figure 20, and tested with the simulator, proved that such a console would occupy a significant part of the FOV, even though it could be moved along the rail according to the user. In addition, if the console should be placed on the forwards or backwards facing railings, the controllers' directions would shift, possibly confusing the captain. These two drawbacks shifted the focus over on other console concepts.

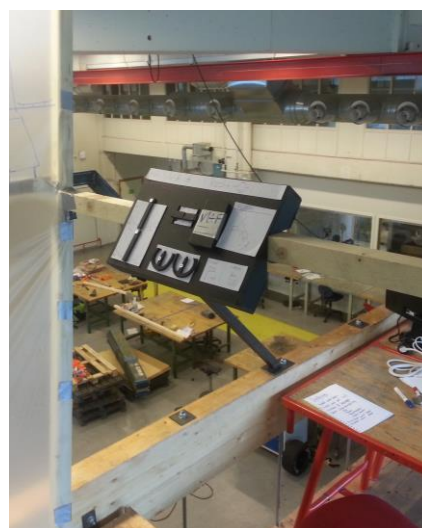

*Figure 20: Rail console, second version*

**Learnings: Obstructs FOV. Tiring arm movement**

**Positive outcomes: Placed directly in front of user.**

## 7.5 Body console – B01 & B02

Once again, the prototype mentioned in 7.2.1 and 7.4 (C01 and R01) was reused, this time to visualize and experience a body mounted console, in this case strapped to the waist by a belt. Another foamboard console (B02) was built, narrower than the previous and with a more ergonomic transition to the human body. This model also tried



Figure 21: Second version body console with side panel controllers.

to utilize the vertical sides of the console, see Figure 21, by placing controller interfaces around the sides. The body console prototypes were discarded due to the challenges of adapting the consoles to different body shapes and sizes

**Learnings: Control handles move relative to the ship when the user moves. Hard to adjust to different users' shapes and sizes.**

**Positive outcomes: Statically in the immediate proximity relative to the user.**

## 8 Field of view analysis

The single most important feature of a bridge wing is to maximize the overview of the ships port or starboard surroundings, primarily facing the dock, another ship during lightering, and an oilrig during loading/unloading, or as viewpoint to increase overview during narrow waterway navigation. This critical function needs to be carefully considered and optimized so that the captain and his crew could focus their concentration on controlling the ship safely during various operations. Therefore, in this study, there was a critical need for a better understanding of the FOV on the SBW. To improve the knowledge about this feature, small-scale models, approximately 1:15, made out of foam board represented different designs, all made rapidly. In the following sub-sections, the setups used to evaluate the FOV is presented in detail.

The need for an undisturbed view of the ships side when docking is confirmed through several visits to ships, as well as a full size ship-simulator. Many of today's ships have large blind spots from the steering position of the bridge wing, both of the ships side and surroundings. The blind spots is often a result of small windows, large window frames and solid floors and walls.

### 8.1 Field of view analysis – setup 1

The small scale models of the bridge wing, cut out foamboard with windows, was fitted at the top of a whiteboard with a small LED lamp inside, shown in Figure 22. The LED, placed where a captain usually stands during operation, represented his eyesight. The emitted light flowed through the windows, and the structure casted shadows dependent of the design. The setup included three different designs, and their shadows were outlined in different colours by hand in order to compare the different FOVs.

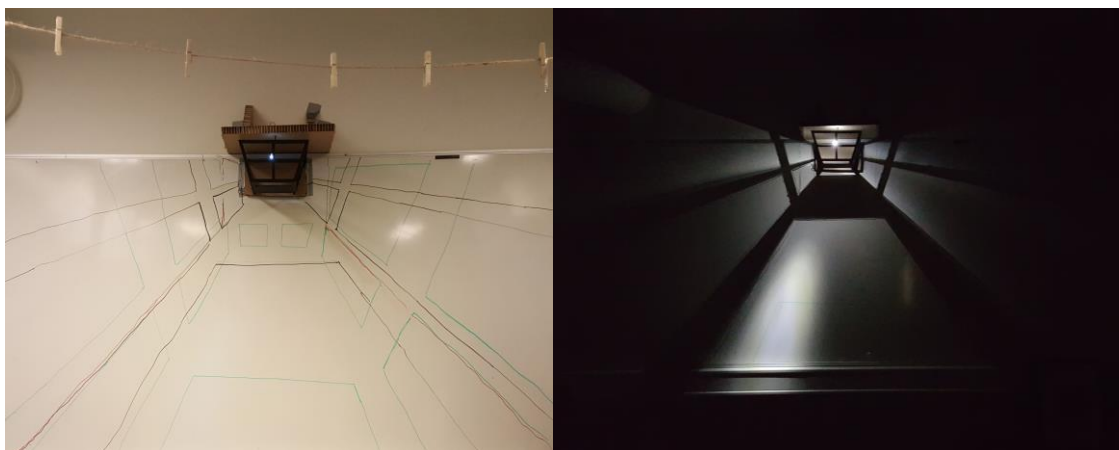

Figure 22: FOV analysis, setup one and two.

---

FOV setup 1 predicted the field of view inwards and along the shipside, and to some extent directly below the bridge wing, shown in the right figure. The main view in the outward direction from the ship (directly towards the camera above) was not included in this setup. The final outlines of the shadows from all the models is presented to the left in Figure 22.

## 8.2 Field of View Analysis – setup 2

To incorporate a more complete FOV in the analysis, a large cardboard box measuring 1,2m x 1,2m x 2m (W x L x H), was made. The small models from setup 1, including a stronger LED light, hung at the top of the far wall in the cardboard box. The light casted shadows and light at the surrounding walls and floor, see Figure 23. This meant that the height of the bridge wing represented was about 28m, and a blind spot of 1m in real life corresponded to a shadow of 6,5cm in the box. The setup characterizes a FOV spanning 180 degrees horizontal and vertical, thus representing the user's ability to turn his or her head, completing the FOV necessary from a bridge wing. As in setup 1, the contours from the shadows was sketched to compare the FOV from the different designs. This setup resulted in a more extensive mapping of the FOV from the different designs. The outcome is discussed in the following chapter.



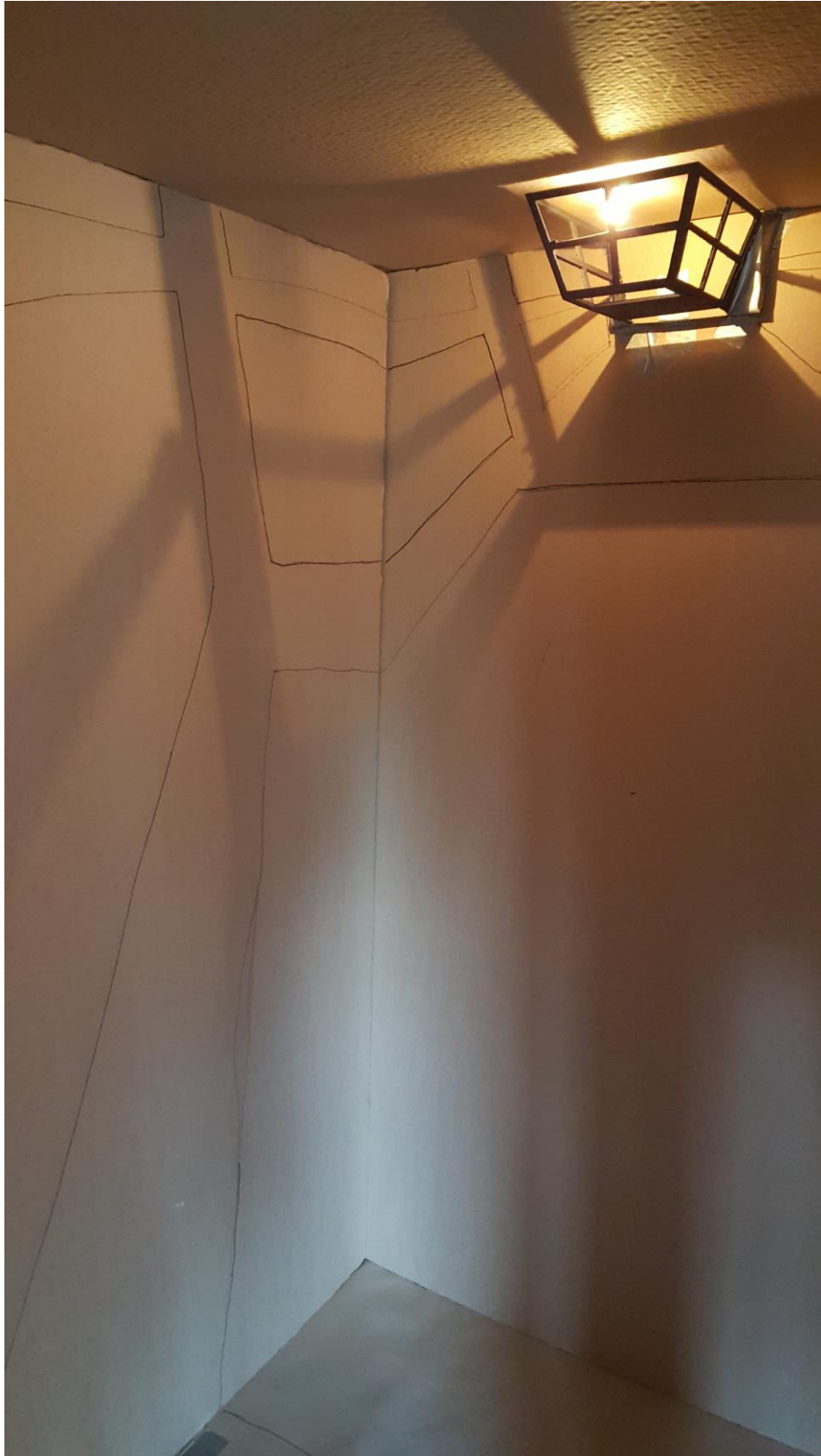

*Figure 23: FOV analysis, setup 2.*

## 9 Outcomes

### 9.1 Bridge wing environment

After a long period of searching for technology and developing the concepts for consoles, we looked back to the different tasks for the two officers on the SBW. An idea came to mind that the console could be divided into two parts, each focusing on the different officers' individual tasks. If the captain is manoeuvring the ship while the First Mate is

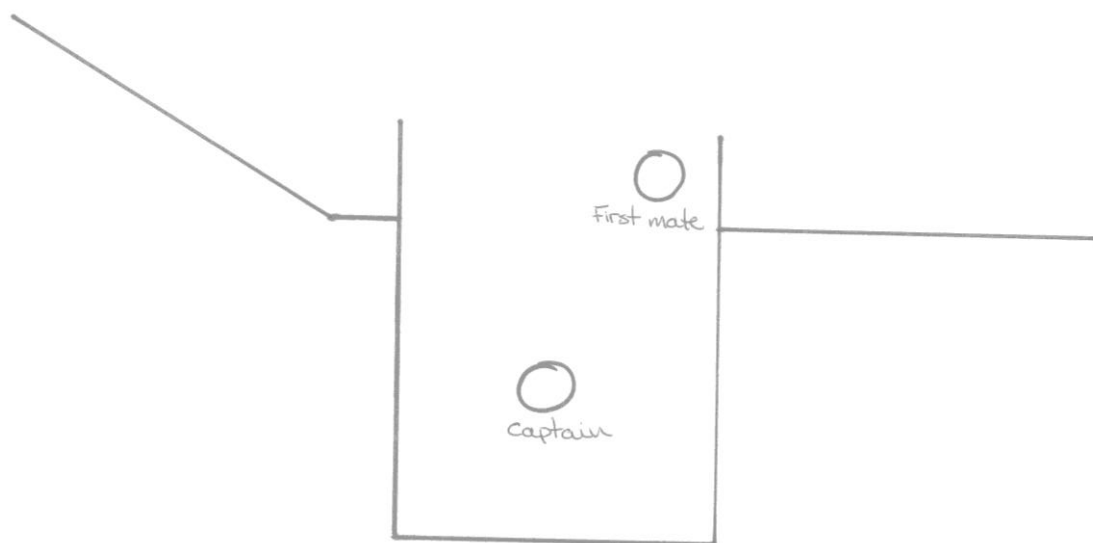

Figure 24: Top view illustration of positions in the SBW (size not to scale).

handling communications, alerts and power switches, they are using independent parts of the console. If the console is split into two parts, the First Mate's console can then be placed further back, and thus clearing up space on the SBW for the captain, see Figure 24.

#### 9.1.1 The captain's position

Three main areas must be taken into account for the person manoeuvring the ship; FOV, control handles, and feedback from the ship.

A good FOV requires good visibility through the windows and few obstructions. Large windows reaching down to the floor with the least amount of interfering beams and a floor window large enough and placed in such a way that the edge of the dock is visible from any position that the captain might stand, satisfies a good FOV. Further, the window should be implemented with automatic brightness adjustment, and could include a head up display, as long as the information displayed is useful and not stealing the attention.

The captain's console needs to contain any controllers for manoeuvring the ship. This means rudder control, and power controls for main propellers or azimuth thrusters and stern and bow thrusters. Any other action buttons can be left for the First Mate.

Even though current SBW consoles often contains conning display, ECDIS and radar display, only conning displays give relevant information during docking. ECDIS have too low resolution to actually see the dock and details in the harbour, and the radar is not relevant in close proximity to the quay. This means that one can reduce the captain's screens to just the conning display. Other information that could be of interest are distances from the ship to dock or objects at sea and current depth. This information could also be appropriate to show on the windows by head up display, but this needs more testing. Our general thought is that such information should be easily visible, and could be placed at the peripherals of the windows.

### 9.1.2 The First Mate's position

While the captain manoeuvres the ship, the First Mate takes care of the other tasks. He needs to be able to switch on or off the power for different engines, take care of alarms, use the ship horn and communicate with other ship personnel and crew outside the ship. He also has interest in information from conning display. If projected on the windows this would be visible for both. The relevant buttons can be placed as a panel on the wall besides the First Mate (Figure 24), together with communication tools such as VHF and UHF. To prevent a scattered panel full of buttons, the panel could be a feedback touchscreen with an additional conning display and buttons appearing if needed.

### 9.1.3 Field of view

Our analysis of the SBW design and FOV led to the discovery that minor changes could improve the situation of today's designs, if one assumes the same bridge wing position (see section 9.1.1). Further, to increase the FOV beyond what is visible to the human eye from the SBW, one could take advantage of augmented reality. "Projecting" what lies on the other side of and behind the ship, on to the shipside visible from the bridge wing in action, see Figure 25. The black lines indicates obstacles, and the red area illustrates the ships boundaries.



Figure 25: Augmented reality on the shipside.

## 9.2 Console design

An early evaluation of the four main types of consoles was done after making the basic ship simulator for the mock-up SBW. The console panel was placed on 4 simple prototypes, representing a floor, rail, ceiling and body based console. An evaluation sheet was created with categories covering important user concerns. These were ranked by operating the simulator for a given period with each of the setups. This gave us a certain overview over advantages and disadvantages about each of the setups, but not enough to pinpoint which would be the most preferable. The individual preferences were too far apart to give an idea of which to focus on at that moment. The key findings, after visiting ships and weeks of prototyping and testing, are:

- Placing the user in front or behind the console have their strengths and weaknesses
  - Placing the user behind the console, means that a part of the FOV inevitably will be stolen, thus forcing the user to move himself or the console to see behind it. However, the handles are placed in a comfortable position relative to the user during SBW operations.
  - Placing the user in front of the console, means that the user must reach backwards or turn around when looking out from the ship to operate the handles. The advantage is that this setup will in most cases not interfere with the FOV.
- Space is desirable. Consoles should take up as little space in the SBW as possible.
- Support beams that carry ceiling based consoles can be of considerable disturbance if placed close to the user's head.
- Floor based console can obstruct the users leg movement.
- The console can be split in two units, one for each of the two officers working on the SBW, since they have different tasks.

Table 1: Characteristics and placement identification and evaluation of the consoles.

Characteristics	C01	C02	C03	C04	F01	F02	F03	F04	F05	F06	R01	R02	B01	B02		
Tilt		○	○	●			●		●						Integration	Symbol
Height adj.	○	●		○	○	●	○	●	○	●					Fully	●
Width adj.									○	●					Semi	○
Rotation	○	●	●	●	●	○	○	○	○	○					Evaluation	Colour
Controls in front	○	○	○	○	○	○	●				●	●	●	●	Keep	●
Controls behind	○	○	○	○	○	○	○	○	○	○					Preferrable	○
Controls on the side	○	○	○	○	○		○	●	●	●	○	○			Discard	●
<b>Placment</b>															Inconclusive	
Cieling	●	●	●	●												
Center floor					○	○	○	●	●	●						
Front floor					○	○	●									
Rail											●	●				
Body													●	●		

Further, the prototypes and tests led to a series of both predicted and unpredicted outcomes and learnings. Table 1 summarizes the characteristics of the consoles, and presents an evaluation of each of them. This table highlights which prototype lead to the discovery of what characteristics to keep, discard or needed more work before a deciding upon it. The attributes mentioned in Table 1 does not include a dedicated solution to how such a trait may be implemented, but it states whether it should be present or not. Other pros and cons of the different consoles and concepts are presented in Table 2.

Table 2: Pros and cons of console prototypes

<i>Console</i>	<i>Pros</i>	<i>Cons</i>	
<i>Ceiling</i>	C01	<ul style="list-style-type: none"> <li>• Free movement</li> <li>• Various positions</li> </ul>	<ul style="list-style-type: none"> <li>• Complex motions</li> </ul>
	C02	<ul style="list-style-type: none"> <li>• Free movement</li> <li>• Height adjustment</li> </ul>	<ul style="list-style-type: none"> <li>• Obstructing FOV</li> <li>• Close to the head</li> </ul>
	C03	<ul style="list-style-type: none"> <li>• Open FOV</li> </ul>	<ul style="list-style-type: none"> <li>• Close to the head</li> </ul>
	C04	<ul style="list-style-type: none"> <li>• Flexible panel position</li> <li>•</li> </ul>	<ul style="list-style-type: none"> <li>• Too many joints</li> </ul>
<i>Floor</i>	F01	<ul style="list-style-type: none"> <li>• Free horizontal movement</li> <li>• Positioning freedom</li> </ul>	<ul style="list-style-type: none"> <li>• Large base</li> </ul>
	F02	<ul style="list-style-type: none"> <li>• Height regulation</li> <li>• Occupies small space</li> </ul>	<ul style="list-style-type: none"> <li>• Tilted away from user</li> </ul>
	F03	<ul style="list-style-type: none"> <li>• Many steering positions</li> <li>• Adjustable tilt</li> </ul>	<ul style="list-style-type: none"> <li>• Obstructs FOV</li> </ul>
	F04	<ul style="list-style-type: none"> <li>• Opens FOV</li> <li>• Height regulations</li> <li>• Separates aft and bow controllers</li> </ul>	<ul style="list-style-type: none"> <li>• Large stands</li> </ul>
	F05	<ul style="list-style-type: none"> <li>• Physical support</li> <li>• Width adjustment</li> </ul>	<ul style="list-style-type: none"> <li>• Tilting as height regulation</li> </ul>
	F06	<ul style="list-style-type: none"> <li>• Height adjustment</li> <li>• Width adjustment</li> <li>• Opens FOV</li> </ul>	<ul style="list-style-type: none"> <li>• Fairly large</li> </ul>
<i>Body</i>	B01	<ul style="list-style-type: none"> <li>• User free to move</li> <li>• Constant position in relation to user</li> </ul>	<ul style="list-style-type: none"> <li>• Long extension from body</li> <li>• Shift in direction according to ship</li> </ul>
	B02	<ul style="list-style-type: none"> <li>• Same as B01</li> <li>• Fixed to user</li> </ul>	<ul style="list-style-type: none"> <li>• “universal” design</li> </ul>
<i>Rail</i>	R01	<ul style="list-style-type: none"> <li>• In front of user</li> <li>• Frees up space</li> </ul>	<ul style="list-style-type: none"> <li>• Occupies FOV</li> </ul>
	R02	<ul style="list-style-type: none"> <li>• Same as R01</li> </ul>	<ul style="list-style-type: none"> <li>• Occupies FOV</li> <li>• Promotes up/down arm movement</li> </ul>

The console concepts, which by the authors’ opinions shows the most potential so far is in particular F06, but also C04, see Figure 26. The ceiling console, C04, is showed to the left, and the floor console, F06, to the right. However, they should both go through further iterations, as discussed in the following chapter.



*Figure 26: The most promising consoles so far.*

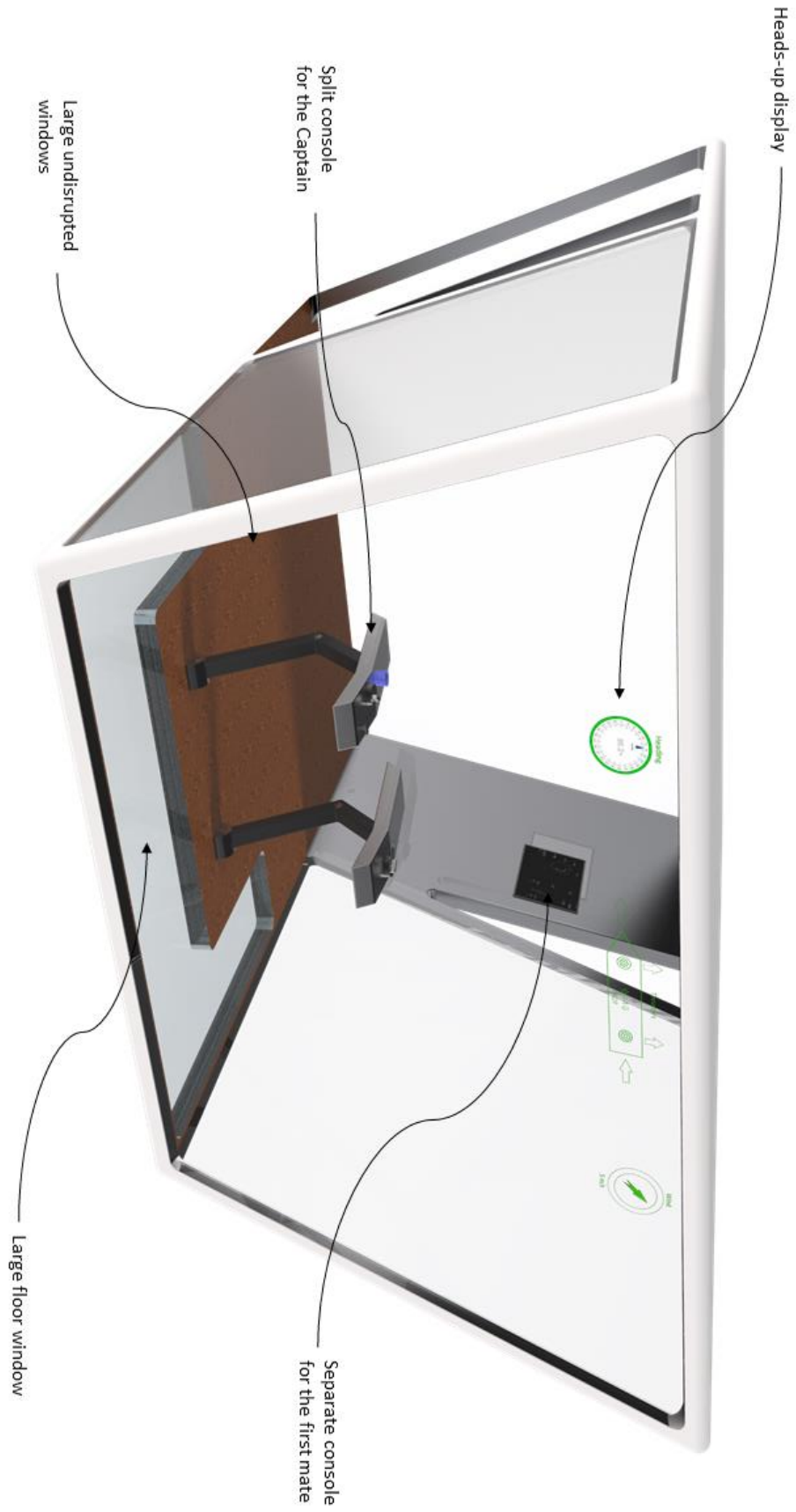

Figure 27: Future concept proposition



## 10 Discussion and Further Work

A ship bridge, with its responsibility and demand for reliability to both the direct and indirect users, should support and ease the bridge personals duties, rather than forcing them to adapt and make workarounds. Of course, certain aspects will need compromising, but the goal of every development change should be to adapt to the user, not the other way around. The fact that we in this report focus on easing the captain and his crews everyday job, through minimizing the impact from the consoles, increasing their perception of the surroundings and isolate tasks performed by different persons, cannot be done without certain requirements and compromises. For instance, the statement from section 7.3.1, that a smaller floor console results in various possible working positions, requires a substantial reduction in the consoles size, implying a reduction in the number of buttons and controllers on the consoles surface.

The reason for all the buttons and controllers available on the SBW is regulations and rules from certification societies and laws. Although these regulations have been fully ignored throughout this project to increase the innovativeness, we are still well aware of the need for redundancies for safety. With a console setup such as described in section 9.1, all the critical functions in the SBW should be well within reach for both officers, in case one is incapacitated.

After having looked at several console designs and setups to improve the SBW, it is still no indication to what is the ultimate console. Personal preferences is an important factor. From the people we have interviewed, opinions and preferences have been diverse, even amongst ourselves. Along with the fact that people come in different shapes and sizes, this indicates that personal adjustments is an important consideration when designing consoles.

It is important to notice the difference between the different consoles when considering the individual concept's characteristics presented in Table 1. A floor console would need other attributes than a ceiling console and so on, thus resulting in the different decisions of which characteristics to keep and/or discard. As Table 1 also shows, the rail and body console lacks further evaluations. This is because their potential was considered less than that of the ceiling and floor console at an early stage, thus resulting in more work and iterations on the two latter. As the work progressed, the split floor console showed the most potential. When testing the last prototype, F06 (to the right in Figure 26), we found that it may profit from being two separate modules, instead of originate from the same stand behind the user,

thus open up for more flexibility. Figure 27 shows a suggested future concept with key findings from this project is implemented and highlighted. A runner up concept is the latest ceiling console C04, though test proved that we could reduce the number of joints. This console further requires a firm locking mechanism combined with smooth movement possibilities to ensure a flawless operation. To solve the problem of a console panel in front of the user, it might be split to resemble that of the floor console.

When we made the decision to split the steering console (F04, F05 and F06), we offered the captain an option to multitask in a more natural way. This resembles that of a crane or excavator, where multitasking (using both hands simultaneously) works well. However, a captain on a ship may not need to perform simultaneous adjustments to the same extent as a crane or excavator, but it grants the ability to separate the bow and stern power controllers and thereby decreasing the chances of turning the wrong controller. The split console also offers a great deal of personal adjustments.

To account for the FOV beyond that visible to the naked eye, i.e. behind the ship, we suggested augmented reality as a solution. This option has its difficulties and challenges, especially because of the dynamic positioning of the captain. As Drascic and Milgram (1996) mentions, the problem of aligning the projections with the ever-changing point of view of the captain is solved mathematically, but lacks accuracy in measurement of the captains point of view and practical implementation. As far as our research goes, this level of detail is still not accounted for without the use of on-body attachments, which might disturb the user.

As the User is central and highly dependent on the solution developed in this project, it would be preferable to engage in a more frequent communication and testing with them. However, it proved difficult to get naval officers, crewmembers, simulator crew and other stakeholders to visit us at NTNU, as well as bringing our prototypes to them, especially with the later, larger prototypes. In addition, the shipping industry is highly conservative, directed by harsh regulations. By presenting our ideas verbally, which many stakeholders perceives like very radical ideas, led to restrained answers and discussions. We did unfortunately not manage to get on board a more modern ship during our research, but at NorShipping, we saw several proposals for new ship bridge designs, consoles, modules, control stations and tools. Some of which, however, had similar pain points as older models, which increased our interest in the project.

Another user and stakeholder we would like to involve more in the future work is the younger naval officers, both undergoing education and newly graduated. When reaching out to them towards the end of this semester, we met a more intrigued and optimistic group, thus the potential for good, non-restrained feedback is higher. A more elaborate research on and connection to such stakeholders would be preferable in the future work needed to develop the next generation ship bridge wing.

As our outcomes of this project does not include implementation of controllers, or interactions with them, a more elaborate research concerning the controllers and how to adapt them to the users should be done in the future, preferably by reducing the amount. In addition, a more detailed process of evaluating how the attributes from Table 1 may be solved and implemented is yet to be determined, as well as optimize the combination of the aspects covered. The console dedicated to the First Mate also needs further testing and development.

## 11 The development process outcome

In DT and Wayfaring manners, we have gone through a non-linear process of empathizing, immersing, ideating, prototyping, testing and evaluating. Our way of approaching the challenge of reinventing the SBW with a focus on the user started with an initial round of ideating around who the users are and what they do in a SBW. We brought low-resolution prototypes on visits to different stakeholders and got a wider perspective considering their feedback during further prototyping. Since we during the project have focused on consoles, FOV and information (prioritized in that order), we have solved “progress-stops” in between evaluation and redefining by moving on to one of the other focus areas. In this way, we have managed to get new fresh ideas once moving back to the previous focus area.

One thing that has made especially this product development project challenging is the scale of the user environment. Ships have proportions that make it challenging to imagine how a product like a SBW or anything in it, will work in its proper environment during prototyping. Even our test area 5 meters above a workshop floor becomes small compared to standing on a ship’s bridge wing situated five times higher above a harbour dock.

During this project, we have many times reached ambiguous situations that have been challenging to handle. After finishing and testing prototypes, we have many times met a dead end. We have experienced that finishing a prototype made us ask questions such as; “what do we learn from this?” and “what’s next?”. Many times during a session of ideating, we have reached a conclusion that we had met before. However, after every ambiguous jam, we have managed to spin out of it. We have, during our project, been well trained within rapid prototyping, and increased our skills in solving ambiguous moments such as described.

The process of rethinking the ship bridge wing led to a good starting point for further concept development for both SBW consoles and the SBW as a total.

## 12 Conclusion

Findings from this project contemplates several different areas. Considering consoles, high degrees of mobility is probably not a particularly important issue as the user remains within a small space most of the time. Locking it in position is on the contrary crucial, and so is toughness against occasional bumps and vibrations. The ability to make adjustments is another area of focus. Ship officers come in different sizes and a completely fixed console does not give a good working position for everyone, proved through ship visits. While on the subject of adjustments, another problem area is the effect of turning the console. By allowing the console panel to rotate, the new direction and position of the controllers may lead to confusion. Having the console or parts of it, in front of the user may also deteriorate the FOV. By taking these factors into account and prototyping different console setup, we have reached a design with the prototype called F06, that we feel is a good foundation towards a final concept. As of now, this concept does not require new technology to be invented, but it might be a struggle to bend the rules and regulations for it to enter a real ship bridge wing.

Another important focus area has been the SBW as a working platform. To optimize the environment, the most important factors are maximizing the FOV and making the space in the SBW as free as possible. Concerning the FOV, big windows reaching from floor to ceiling, as well as a floor window large enough and placed such that the user sees directly down at the ships waterline will satisfy the FOV. User information, further enhanced by displaying conning data on the windows, will increase the navigational attention of the captain, as long as it does not disturb the view. In addition, information regarding distances, projected routes and surroundings may also be projected on the windows, though alignment issues of augmented reality needs further development.

This project ultimately led to a suggestion for reconfiguring the workspace for the two people working in the SBW. The captain stands in the outer part of the SBW controlling the ship, where the FOV is at its most complete, supported by an adapted console. The First Mate stands behind him with a console panel controlling communication and other actions depending on the situation. Whether this leads to the best concept remains uncertain, since the development is still at an early phase.

It is important to point out that the research done throughout this project is not by far finished. The last prototype built is in no way a final concept, but it builds upon a series of

steps in the right direction of establishing one. After all, the last prototype had aspects that could have been improved and this shows potential for further work.

## 13 Bibliography

- Brown, T. (2008). Design thinking. *harvard business review*, 86(6), 84.
- Buchenuau, M., & Suri, J. F. (2000). *Experience prototyping*. Paper presented at the Proceedings of the 3rd conference on Designing interactive systems: processes, practices, methods, and techniques.
- Carter, R. (2006). Boat remains and maritime trade in the Persian Gulf during the sixth and fifth millennia BC. *Antiquity*, 80(307), 52-63.
- Dow, S. P., Heddleston, K., & Klemmer, S. R. (2009). *The efficacy of prototyping under time constraints*. Paper presented at the Proceedings of the seventh ACM conference on Creativity and cognition.
- Drascic, D., & Milgram, P. (1996). *Perceptual issues in augmented reality*. Paper presented at the Electronic Imaging: Science & Technology.
- Eurostat. (2014). Passenger Transport Statistics. Retrieved from [http://ec.europa.eu/eurostat/statistics-explained/index.php/Passenger\\_transport\\_statistics](http://ec.europa.eu/eurostat/statistics-explained/index.php/Passenger_transport_statistics)
- Gerstenberg, A., Sjöman, H., Reime, T., Abrahamsson, P., & Steinert, M. (2015). A Simultaneous, Multidisciplinary Development and Design Journey—Reflections on Prototyping *Entertainment Computing-ICEC 2015* (pp. 409-416): Springer.
- Houde, S., & Hill, C. (1997). What do prototypes prototype. *Handbook of human-computer interaction*, 2, 367-381.
- Khurana, A., & Rosenthal, S. R. (1997). Integrating the fuzzy front end of new product development. *Sloan management review*, 38, 103-120.
- Kim, J., & Wilemon, D. (2002). Focusing the fuzzy front-end in new product development. *R&D Management*, 32, 269-279.
- Leifer, L. J., & Steinert, M. (2014). Dancing with ambiguity: Causality behavior, design thinking, and triple-loop-learning *Management of the Fuzzy Front End of Innovation* (pp. 141-158): Springer.
- Lim, Y.-K., Stolterman, E., & Tenenberg, J. (2008). The anatomy of prototypes: Prototypes as filters, prototypes as manifestations of design ideas. *ACM Transactions on Computer-Human Interaction (TOCHI)*, 15(2), 7.
- Meinel, C., & Leifer, L. (2010). *Design thinking research*.
- Moenaert, R. K., De Meyer, A., Souder, W. E., & Deschoolmeester, D. (1995). R&D/marketing communication during the fuzzy front-end. *Engineering Management, IEEE Transactions on*, 42(3), 243-258. doi:10.1109/17.403743
- Murphy, S. A., & Kumar, V. (1997). The front end of new product development: a Canadian survey. *R&D Management*, 27(1), 5-15. doi:10.1111/1467-9310.00038
- Reid, S. E., & De Brentani, U. (2004). The fuzzy front end of new product development for discontinuous innovations: a theoretical model. *Journal of product innovation management*, 21(3), 170-184. doi:10.1111/j.0737-6782.2004.00068.x
- Reinertsen, D. G. (1999). Taking the fuzziness out of the fuzzy front end. *Research-Technology Management*, 42(6), 25-31. Retrieved from <Go to ISI>://WOS:000083524900007
- Smith, P., & Reinertsen, D. (1991). *Developing new products in half the time*: Van Nostrand Reinhold Books, New York, NY.
- Snowden, D. J., & Boone, M. E. (2007). A leader's framework for decision making. *harvard business review*, 85(11), 68.
- Steinert, M., & Leifer, L. J. (2012). 'Finding One's Way': Re-Discovering a Hunter-Gatherer Model based on Wayfaring. *International Journal of Engineering Education*, 28(2), 251.
- Ulrich, K. T., & Eppinger, S. (2012). *Product Design and Development, 2012*: McGraw-Hill, New York, NY.





## Appendix A – Assignment Text

THE NORWEGIAN UNIVERSITY  
OF SCIENCE AND TECHNOLOGY  
DEPARTMENT OF ENGINEERING DESIGN  
AND MATERIALS

**PROJECT WORK AUTUMN 2015  
FOR  
STUD.TECHN. Erik Karlsson & Ferdinand O. Solvang**

**Next generation ship bridge wing**

***Neste generasjon skipsbrovinge***

Rethink and further develop the ship bridge wing, by focusing on the following aspects:

- Console design
- Bridge wing design
- Field of view
- Information feedback with special regards to haptic and/or tactile touchscreens

The work is a combination of literature, experimental and free early stage conceptual prototyping activities. The intended outcome level should allow feasibility decision to commence R&D projects and work as repository for a possible academic publication in 2016.

**Formal requirements:**

Students are required to submit an A3 page describing the planned work three weeks after the project start as a pdf-file. A template can be found on IPM's web-page (<https://www.ntnu.no/ipm/prosjekt-og-fordypningsemner>).

Performing a risk assessment is mandatory for any experimental work. Known main activities must be risk assessed before they start, and the form must be handed in within 3 weeks after you receive the problem text. The form must be signed by your supervisor. Risk assessment is an ongoing activity, and must be carried out before starting any activity that might cause injuries or damage materials/equipment or the external environment. Copies of the signed risk assessments have to be put in the appendix of the project report.

No later than 1 week before the deadline of the final project report, you are required to submit an updated A3 page summarizing and illustrating the results obtained in the project work.

Official deadline for the delivery of the report is 15 December 2015 at 3 p.m. The report is to be delivered in two paper copies and one electronic version via email to [iipmprosjekt@ivt.ntnu.no](mailto:iipmprosjekt@ivt.ntnu.no).

When evaluating the project, we take into consideration how clearly the problem is presented, the thoroughness of the report, and to which extent the student gives an independent presentation of the topic using his/her own assessments.

The report must include the signed problem text, and be written as a scientific report with summary of important findings, conclusion, literature references, table of contents, etc. Specific problems to be addressed in the project are to be stated in the beginning of the report and briefly discussed. The report should not exceed thirty pages including illustrations and sketches.

Additional tables, drawings, detailed sketches, photographs, etc. can be included in an appendix at the end of the thirty page report. References to the appendix must be specified. The report should be presented so that it can be fully understood without referencing the Appendix. Figures and tables must be presented with explanations. Literature references should be indicated by means of a number in brackets in the text, and each reference should be further specified at the end of the report in a reference list. References should be specified with name of author(s) and book, title and year of publication, and page number.

Contact persons:

At the department : Martin Steinert, TBD  
From the industry : Espen Strange (KM)



Martin Steinert  
Supervisor

 **NTNU**  
Norges teknisk-  
naturvitenskapelige universitet  
Institutt for produktutvikling  
og materialer

## Appendix B – Risk Assessment

NTNU		Kartlegging av risikofylt aktivitet		Utarbeidet av		Nummer		Dato	
HIMS				HMS-avd.		HMSRV2601		22.03.2011	
				Godkjent av				Erstatter	
				Rektor				01.12.2006	

Enhet: Department of engineering design and materials

Dato: 2015.09.07

Linjeleder:

Deltakere ved kartleggingen (m/ funksjon): Martin Steinert, veileder/ Erik Karlsson, student/ Ferdinand O. Solvang, student  
(Ansv. veileder, student, evt. medveiledere, evt. andre m. kompetanse)

Kort beskrivelse av hovedaktivitet/hovedprosess: Prosjektoppgave student Erik Karlsson og Ferdinand O. Solvang. Nest generation ship bridge

Er oppgaven rent teoretisk? (JA/NEI): Nei

risikovurdering. Dersom «JA»: Beskriv kort aktiviteteten i kartleggingskjemaet under. Risikovurdering trenger ikke å fylles ut.

Signaturer: Ansvarlig veileder: Martin Steinert

Student: Erik Karlsson og Ferdinand O. Solvang

ID nr.	Aktivitet/prosess	Ansvarlig	Eksisterende dokumentasjon	Eksisterende sikringstiltak	Lov, forskrift o.l.	Kommentar
1	Bruk av Trolllabs workshop.	EK/FOS	Romkort	Romkort		
1a	Bruk av roterende maskineri	EK/FOS	Maskinens brukermanual	Ukjent	Ukjent	
1b	Bruk av laserkutter	EK/FOS	Maskinens brukermanual	Ukjent	Ukjent	
1c	Bruk av 3D printer	EK/FOS	Maskinens brukermanual	Ukjent	Ukjent	
1d	Bruk av skjæreverktøy	EK/FOS	Ukjent			
1e	Bruk av sammenføyningsmidler (lim og lignende.)	EK/FOS	Produktets brukermanual og datablad	Datablad	Ukjent	

NTNU



HMS

## Kartlegging av risikofylt aktivitet

Utarbeidet av	Nummer	Dato	
HMS-avd.	HMSRV2601	22.03.2011	
Godkjent av		Erstatter	
Rektor		01.12.2006	

2	Tilstedeværelse ved arbeid utført av andre.	Andre	Andres HMSRV2601	Andres HMSRV2601	Prosessavhengig
3	Eksperimentelt arbeid	EK/FOS	Egen risikovurdering- må gjøres for hvert enkelt eksperiment		Prosessavhengig

## Risikovurdering

 Utarbeidet av  
 HMS-avd.  
 Godkjent av  
 Rektor

 Nummer  
 HMSRV/2601  
 Dato  
 22.03.2011

 Erstatte  
 01.12.2006

ID nr	Aktivitet fra kartleggings-skjemaet	Mulig uønsket hendelse/belastning	Vurdering av sannsynlighet (1-5)	Vurdering av konsekvens:				Risiko-Verdi (menneske)	Kommentarer/status Forslag til tiltak
				Menneske (A-E)	Ytre miljø (A-E)	Øk/ materiell (A-E)	Om-dørmme (A-E)		
1	Bruk av Trolllabb workshop.								
1a-i	Bruk av roterende maskineri	Stor kuttskade	2	D	A	A	D	2D	Sørg for at roterende deler er tilstrekkelig sikret/dekket. Vær nøye med opplæring i bruk av maskineri.
1a-ii		Liten kuttskade	3	B	A	A	A	3B	Vær nøye med opplæring i bruk av maskineri. Ikke ha løse klær/tilbehør på kroppen.
1a-iii		Klemskade	2	D	A	A	C	2D	Vær nøye med opplæring i bruk av maskineri. Ikke ha løse klær/tilbehør på kroppen.
1a-iv		Flygende spon/gjenstander	3	C	A	A	B	3C	Bruk øyevern og tildekk hurtig roterende deler (Fres og lignende.)
1a-v		Feil bruk-> ødelagt utstyr	3	A	A	C	A	3C	Vær nøye med opplæring i bruk av maskineri
1b-i	Bruk av laserkutter	Klemskade	2	D	A	A	C	2D	Vær nøye med opplæring i bruk av maskineri. Ikke ha løse klær/tilbehør på kroppen.
1b-ii		Brannskade	3	B	A	A	A	3B	Vær nøye med opplæring i bruk av maskineri. Bruk hansker ved håndtering av varme materialer.

NTNU		<h1>Risikovurdering</h1>				Utarbeidet av		Nummer		Dato	
 HMS						HMS-avd.		HMSRV2601		22.03.2011	
						Godkjent av		Rektor		Erstatter	
											

1b-iii	Øyeskade-laser	2	D	A	A	C	2D	Bruk øyevern! Skru av laser når maskinen ved oppsett.
1b-iv	Brann	2	B	A	D	C	2B	Vær nøye med opplæring i bruk av maskin. Ha slukkeutstur tilgjengelig
1c-i	Brannskade	3	B	A	A	A	3B	Vær nøye med opplæring i bruk av maskin.
1c-ii	Innhalering av plast/printemateriale	5	A	A	A	A	5A	Bruk åndedretsvern/ vernebriller
1c-iii	Feil bruk-> ødelagt maskineri	3	A	A	C	A	3A	Vær nøye med opplæring i bruk av maskin.
1d-i	Stor kuttskade	2	D	A	A	D	2D	Bruk skapre verktøy og riktig skjæreunderlag
1d-ii	Liten kuttskade	3	B	A	A	A	3B	Bruk skapre verktøy og riktig skjæreunderlag
1e-i	Eksposering på øyet	2	D	A	A	B	2D	Bruk øyevern, ha datablad tilgjengelig
1e-ii	Eksposering hud	4	A	A	A	A	4A	Bruk hansker, ha datablad tilgjengelig
1e-iii	Eksposering åndedrett	4	A	A	A	A	4A	Bruk åndedretsvern/ god ventilasjon. Ha datablad tilgjengelig.



NTNU	<b>Risikovurdering</b>				Utarbeidet av	Nummer	Dato
					HMS-avd.	HMSRV/2601	22.03.2011
HMS					Godkjent av Rektor		Erstatter 01.12.2006



1e-iv	Søl	4	A	B	A	A	4A	Ha papir/ rengjøringsmaterieell tilgjengelig. Ha datablad tilgjengelig.
2	Tilstedeværelse ved arbeid utført av andre.	3	C	C	C	C	3C	Hold et øye med hva som foregår rundt deg.
3-i	Eksperimentelt arbeid	1	A	A	A	D	1E	Bruk redningsvest i båt og lignende.
3-ii	Elektrisitet- strøm	3	B	A	A	A	3V	Typisk lite energi involvert. Bruk isolerte verktøy
3-iii	Ulykke på skip	1	D	D	B	B	1D	Følg regler og prosedyrer ombord

NTNU	Risikovurdering			Utarbeidet av	Nummer	Dato
				HMS-avd.	HMSRV2601	22.03.2011
HMS	Godkjent av		Erstatter			
	Rektor		01.12.2006			



### Sannsynlighet vurderes etter følgende kriterier:

Svært liten 1	Liten 2	Middels 3	Stor 4	Svært stor 5
1 gang pr 50 år eller sjeldnere	1 gang pr 10 år eller sjeldnere	1 gang pr år eller sjeldnere	1 gang pr måned eller sjeldnere	Skjer ukentlig

### Konsekvens vurderes etter følgende kriterier:



Gradering	Menneske	Ytre miljø Vann, jord og luft	Øk/materiell	Omdømme
<b>E</b> Svært Alvorlig	Død	Svært langvarig og ikke reversibel skade	Drifts- eller aktivitetsstans > 1 år.	Troverdighet og respekt betydelig og varig svekket
<b>D</b> Alvorlig	Alvorlig personskade. Mulig uførhet.	Langvarig skade. Lang restitusjonstid	Driftsstans > ½ år Aktivitetsstans i opp til 1 år	Troverdighet og respekt betydelig svekket
<b>C</b> Moderat	Alvorlig personskade.	Mindre skade og lang restitusjonstid	Drifts- eller aktivitetsstans < 1 mnd	Troverdighet og respekt svekket
<b>B</b> Liten	Skade som krever medisinsk behandling	Mindre skade og kort restitusjonstid	Drifts- eller aktivitetsstans < 1 uke	Negativ påvirkning på troverdighet og respekt
<b>A</b> Svært liten	Skade som krever førstehjelp	Ubetydelig skade og kort restitusjonstid	Drifts- eller aktivitetsstans < 1 dag	Liten påvirkning på troverdighet og respekt

### Risikoverdi = Sannsynlighet x Konsekvens

Beregn risikoverdi for Menneske. Enheten vurderer selv om de i tillegg vil beregne risikoverdi for Ytre miljø, Økonomi/materiell og Omdømme. I så fall beregnes disse hver for seg.

### Til kolonnen "Kommentarer/status, forslag til forebyggende og korrigerende tiltak":

Tiltak kan påvirke både sannsynlighet og konsekvens. Prioriter tiltak som kan forhindre at hendelsen inntreffer, dvs. sannsynlighetsreducerende tiltak foran skjerpet beredskap, dvs. konsekvensreducerende tiltak.

NTNU		Risikomatrixe		Dato	
		HMS/KS		08.03.2010	
		utarbeidet av		Nummer	
		HMS-avd.		HMSRV2604	
		godkjent av		Erstatter	
		Rektor		09.02.2010	
					

## MATRISSE FOR RISIKOVURDERINGER ved NTNU

KONSEKVENSENS	Svært alvorlig	E1	E2	E3	E4	E5
	Alvorlig	D1	D2	D3	D4	D5
	Moderat	C1	C2	C3	C4	C5
	Liten	B1	B2	B3	B4	B5
	Svært liten	A1	A2	A3	A4	A5
		Svært liten	Liten	Middels	Stor	Svært stor
SANNSYNLIGHET						

Prinsipp over akseptkriterium. Forklaring av fargene som er brukt i risikomatrixen.

Farge	Beskrivelse
Rød	Uakseptabel risiko. Tiltak skal gjennomføres for å redusere risikoen.
Gul	Vurderingsområde. Tiltak skal vurderes.
Grønn	Akseptabel risiko. Tiltak kan vurderes ut fra andre hensyn.