

REVIEW

Open Access



A review of material development in the field of carbon capture and the application of membrane-based processes in power plants and energy-intensive industries

Xuezhong He

Abstract

This review highlights recent developments and future perspectives on CO₂ capture from power plants and energy-intensive industries to reduce CO₂ emissions. Different types of membrane materials for CO₂ capture were reviewed in terms of material performance, energy efficiency, and cost. With regard to gas separation membrane technology, only three types of membranes have been demonstrated at pilot scale. Therefore, this work paid particular attention to recent development of membrane materials such as fixed-site-carrier membranes and ultrathin nanocomposite membranes. The required high-performance membranes with CO₂ permeance of 3 m³(STP)/(m² h bar) and high CO₂/N₂ selectivity (> 40) were identified as the future direction of material development. Moreover, novel energy-efficient process development for CO₂ capture in power plant and process industry are discussed; the MTR patented air sweeping process is considered one of the most energy-efficient processes for post-combustion CO₂ capture. In the last part, CO₂/CH₄ selectivity of > 30 was pointed out to be the requirement of energy-efficient membrane system for CO₂ removal from natural gas and biogas. Finally, significant improvements on membrane material performance, module, and process efficiency are still needed for membrane technology to be competitive in CO₂ capture.

Keywords: CO₂ capture, Membrane, Flue gas, Post-combustion, Natural gas, Biogas

Introduction

The International Energy Outlook [79] (IEO2011) reference case reported that world energy-related carbon dioxide (CO₂) emissions would increase to 35.2 billion metric tons in 2020 and 43.2 billion metric tons in 2035. Control of anthropogenic emissions of greenhouse gases (GHG), especially CO₂, is one of the most challenging environmental issues related to global climate change. Three different solutions can be employed to reduce CO₂ emissions, i.e., improving energy efficiency, switching to use less carbon-intensive and renewable energy, and carbon capture and storage (CCS). Among them, CCS is considered as one of the most promising way which can continuously use fossil fuels without causing significant increase of CO₂ emissions. The main applications of CCS are likely to be at large CO₂ point sources: fossil fuel

power plants and energy-intensive industries such as iron/steel manufacture, refinery, cement factory, and natural gas and biogas plants [1]. Among them, fossil fuel power plants are responsible for the largest CO₂ emissions, and post-combustion power plants are being the main contributors which need to be firstly tackled. Moreover, CO₂ removal from natural gas or biogas is also mandatory as the acid gas can cause pipeline corrosion during gas transportation. CO₂ capture from exhaust gases in cement factory receives particular attention as CO₂ is also a byproduct in a cement production process and cannot be avoided.

Different technologies such as chemical and physical absorption, membrane separation, physical adsorption, cryogenic distillation, and chemical looping can be used for CO₂ capture in various processes [76]. The conventional chemical absorption is a mature technology for CO₂ separation, but is also energy intensive and high cost, which can result in a large incremental cost and a significant

Correspondence: xuezhong.he@ntnu.no
Department of Chemical Engineering, Norwegian University of Science and Technology, N-7491 Trondheim, Norway



environmental impact. Membrane technology has already been commercialized and documented as a competitive technology for selected gas separation processes such as air separation and natural gas sweetening during the last two or three decades. Great effort has been recently placed on CO₂ capture using gas separation membranes, and examples are found in the literature [16, 22, 27, 28, 32, 33, 50, 77, 101, 127, 137, 158]. However, there are still challenges on the applications of membranes for CO₂ capture related to (1) the limitation of membrane separation performance (the trade-off of gas permeance and selectivity of most polymeric membranes) and (2) the poor membrane stability and short lifetime when exposing to a gas stream containing the impurities of acid gases such as SO₂, NO_x. Thus, high-performance membranes with low material cost and high stability should be developed. MTR (Membrane Technology & Research, Inc.) tested their high permeable ultrathin Polaris™ membranes for CO₂ capture in a 1-MW coal-fired power plant with a large pilot system. Moreover, high-performance fixed-site-carrier (FSC) membranes were developed by the NanoGLOWA project (EU FP6) for CO₂ separation. A small pilot-scale system was tested in 2011 for CO₂ capture from flue gas at Sines coal-fired power plant in Portugal (developed by the Membrane Research team (Memfo) at NTNU), and the stable performance over 6 months was reported [138], and their latest pilot system with 20-m² hollow fibers were tested for CO₂ capture in Norcem cement factory [51]. In addition, a 10-m² PolyActive® membrane module developed by Helmholtz-Zentrum Geesthacht was also tested for CO₂ capture [119]. Those efforts have brought membrane technology for post-combustion CO₂ capture to a higher TRL (technology readiness levels). Moreover, some emerging separation technologies based on the novel solvents of ionic liquids (high CO₂ solubility) and microporous materials (solid adsorbents) of zeolite, metal organic frameworks (MOFs), and metal oxides (chemical looping cycle) have been recently developed for CO₂ capture and showed a nice potential and cost reduction benefit [17, 26, 67, 76, 95, 136, 162, 164]. It should be noted that those advanced materials are mostly in the early research phase, and material cost together with upscaling issue need to be further investigated. In this work, the main focus is to provide an overview of the latest development and progress of membrane materials (especially some membranes at high TRL) and membrane-based processes for CO₂ capture from power plants and energy-intensive industries (e.g., cement factory, biogas, and natural gas plants).

Membrane materials for CO₂ capture

Each membrane material has its own advantages and challenges related to material cost, separation performance, and lifetime. Development of advanced membrane materials to increase cost-effectiveness is crucial to bring

down CO₂ capture cost. Different membranes such as polymer membranes, microporous organic polymers (MOPs), FSC membranes, mixed matrix membranes (MMMs), carbon molecular sieve membranes (CMSMs), and inorganic (ceramic, metallic, zeolites) membranes can be used for CO₂-related separation [76]. Each membrane material possesses its own separation property, thermal and chemical stability and mechanical strength. In general, most polymer membranes show good separation performance and relatively low cost, but a relatively low membrane stability by exposure to acid gases and adverse conditions (high temperature and pressure). Inorganic membranes can be operated in these adverse conditions, but module construction and sealing for high-temperature application are quite challenging, and production cost is usually much higher compared to polymer membranes. Novel membrane materials especially FSC and MMMs (summarized in Table 1) attract great interest in the membrane community, which are based on either an enhanced facilitated transport mechanism or combination of both polymeric and inorganic material properties. Thus, choosing a suitable membrane material for a specific application mainly depends on membrane material properties, feed gas composition and flow rate, process operating conditions, and separation requirements [123]. Recently, membrane performance has been significantly improved owing to the great effort that has been taken from the membrane community. Wang et al. [151] summarized the status of single-stage membrane performance in the upper bound plots for CO₂/N₂ and CO₂/CH₄, and most ultrathin polymer membranes stayed closer to both upper bounds compared to the commercial polymers, which indicated the great potential for carbon capture applications. It should be noted that some membranes like the MTR Polaris™ membranes and the FSC membranes (patented by NTNU) have already been demonstrated at pilot scale [51, 106] and are quite promising for CO₂ capture from flue gas due to their high performance and good stability when exposed to a flue gas containing the impurities of SO₂ and NO_x.

Polymer membranes

Polymer membranes have been widely used for selected commercial gas separation processes due to their good separation performance, good mechanical stability, and low cost. Most membrane systems for gas separation use glassy polymers because of their high selectivity and good mechanical properties, and polyimide membranes exhibits excellent high selectivities combined with high permeances for a large variety of applications in gas separation [41], while some rubbery polymers are also used for specific vapor/gas separation processes based on gas solubility difference in membrane materials, e.g., volatile

Table 1 Representative FSC membranes and MMMs for gas separation

Material	Support	Membrane module	Gas separation	Reference
FSC membranes				
Poly(amidoamine)/poly(vinyl alcohol)	–	Flat sheet	CO ₂ /H ₂	[37]
Polyallylamine (PAAm)/poly(vinyl alcohol) (PVA) blend	Polysulfone	Flat sheet	CO ₂ /H ₂ /N ₂ /CO	[166]
PVAm & PVAm/PVA blend	Polysulfone, polyphenylene oxide (PPO)	Flat sheet, Hollow fiber	CO ₂ /N ₂ , CO ₂ /CH ₄	[31, 71, 74, 86, 87, 147, 148]
PVA	–	Flat sheet	CO ₂ /H ₂ /N ₂	[77]
	–	Flat sheet	CO ₂ /CH ₄	[80]
CNT-reinforced PVAm/PVA blend	Polysulfone	Flat sheet	CO ₂ /CH ₄	[62, 63, 66–69]
Nanotube-reinforced PVAm	Polyethersulfone (PES)	Flat-sheet	CO ₂ /N ₂	[58]
High temperature ionic liquids	Nylon	Flat sheet	CO ₂ /H ₂	[110]
Room temperature ionic liquids (RTILs)	polyvinylidene difluoride (PVDF)	Flat sheet	CO ₂ /air, SO ₂ /air, CO ₂ /N ₂ /H ₂	[102, 112]
MMMs				
Polymer matrix	Inorganic filler	Membrane module	Gas separation	Reference
Poly(vinyl acetate) (PVAc)	Zeolite 4A, TiO ₂	Flat sheet	CO ₂ /N ₂	[2–4]
PIMs	ZIF-8, CNTs	Flat sheet	H ₂ /N ₂ , H ₂ /CH ₄ , He/N ₂ , O ₂ /N ₂ , CO ₂ /CH ₄	[21, 82]
Poly(ethylene oxide) (PEO)	Graphene oxide	Flat sheet	CO ₂ /N ₂	[122]
Pebax	1 D multi-walled CNT/graphene oxide nanoribbon	Flat sheet	CO ₂ /N ₂ , CO ₂ /CH ₄	[114]
PIMs	MOFs	Flat sheet	CO ₂ /N ₂	[44]

organic compounds (VOCs) recovery and hydrocarbon recovery from natural gas. Commercial polymeric gas separation membranes are mostly made from cellulose acetate (UOP, GMS, NATCO), polysulfone (Air Products), and polyimides (Praxair), polyphenylene oxide (Parker-Hannifin), and polydimethylsiloxane (GKSS, MTR).

Gas permeability and selectivity are the two key parameters for the characterization of separation performance of dense polymer membranes, which should be as high as possible to achieve separation requirements at a low cost. However, gas permeability is mainly dependent on a thermodynamic factor (solubility (S) of penetrates in a membrane) and a kinetic factor (diffusivity (D) of the gas species transport through a membrane) [7]. Thus, there is a trade-off between permeability and selectivity in the dense polymer membranes as reported by Robeson [129]. The polymer membranes based on a solution-diffusion (S-D) transport mechanism cannot surpass the Robeson upper bound to achieve a higher permeability/selectivity combination unless the membranes involve other transport mechanisms such as molecular sieving and facilitated transport, or have large porosity and fractional free volume (FFV).

Microporous organic polymers

Strong interests have been put on the development of microporous organic polymers due to its large surface area. The representative MOPs include thermally rearranged (TR) polymers [35, 57, 85, 115, 116] and polymers of intrinsic microporosity (PIMs) [5, 18–20, 36, 104, 144, 160]. Polyimide-based TR polymers with an average pore size 0.4–0.9 nm and a narrow pore size distribution was firstly prepared by Park et al. [116], which presented a molecular sieving transport mechanism for gas permeation. The flexible structures provided the feasibility and the easiness for module construction. Moreover, TR polymer membranes were also found to exhibit excellent gas separation performance for CO₂-related separation processes, for examples, CO₂/CH₄ separation in high-pressure natural gas sweetening process [35, 115] and high temperature H₂/CO₂ separation in pre-combustion process [57]. However, most of the efforts are still focused on the development of lab-scale films of TR membranes, only a few literature reported that fabrication of hollow fiber TR membranes [84, 92, 154]. Kim et al. prepared their lab-scale TR-PBO (polybenzoxazole) hollow fiber membranes with a CO₂ permeance of 1938 GPU (1GPU = 2.736 × 10⁻³ m³(STP)/(m² h bar)) [84],

but the CO₂/N₂ selectivity of 13 should be further improved. Woo et al. reported a superior CO₂ permeance of ~ 2500 GPU with a moderate CO₂/N₂ selectivity of 16 of the TR-PBO hollow fibers with ultrathin defect-free skin layer [154], which might be suitable for bulk CO₂ removal from flue gas.

Another type of microporous polymer materials of PIMs attracted great interest due to their relatively slow physical aging, high gas permeability, and high selectivity compared to poly(1-trimethylsilyl-1-propyne) (PTMSP) membranes that initially formed microporous structures are rapidly corrupted [36]. PIMs showed a high surface area (600–900 m²/g) as reported by Budd et al. [18] and a high fractional free volume (22–24% [105]) which is comparable to that of PTMSP membranes (32–34.3% [109, 120]). Du et al. reported that PIMs functionalized with CO₂-philic pendant tetrazole groups (TZPIMs) can further improve CO₂ permeance by increasing CO₂ solubility due to the strong interaction between CO₂ and N-containing organic heterocyclic groups [36]. Their results indicated that CO₂/N₂ separation performance of TZPIMs can potentially surpass the Robeson upper bound. Moreover, a systematic review on preparation, characterization, and application of PIMs has been conducted by McKeown [104]. They pointed out that composite membranes consisting of PIMs and other polymers can present higher gas separation performance.

Fixed-site-carrier membranes

FSC membranes for CO₂ separation attracted great attention due to the high CO₂ permeance and selectivities of CO₂ over other gas species (e.g., N₂ and O₂). The carriers (amino functional group, -NH₂) are chemically bonded onto the polymer main chain. Thus, the FSC membranes usually present a higher stability compared to supported liquid membrane (SLM) and emulsion liquid membrane (ELM). Tong et al. conducted a review on facilitated transport membranes related to transport mechanism and

materials [145]. The gas transport through a facilitated transport membrane is illustrated in Fig. 1, where the CO₂ molecules react with amino functional groups when water is available, and pass through FSC membranes based on the combination of S-D and facilitated transport (FT) mechanism, while the non-reactive gas molecules (e.g., N₂, O₂) can only transport via S-D mechanism as documented by Kim et al. [86]. The gas permeate flux of the reactive component A (such as CO₂) will be the sum of both solution-diffusion and carrier-mediated diffusion (i.e., facilitated transport), which can be expressed as follows [86, 117]:

$$J_A = \frac{D_A}{l}(c_{A,0}-c_{A,1}) + \frac{D_{AC}}{l}(c_{AC,0}-c_{AC,1}) \tag{3}$$

where D_A and D_{AC} are diffusion coefficient of the Fickian diffusion and the carrier-mediated (complex) diffusion, respectively. l is the thickness of the selective layer. Feed pressure is crucial to get high flux by enhancing the contribution from both S-D and FT. However, after the carrier saturation, further increasing feed CO₂ partial pressure will not enhance the FT contribution. Thus, the trade-off between energy consumption and reduced membrane area (with increased flux) should be identified to determine the optimal operating condition [75]. A moderate feed pressure (e.g., 2.5–3 bar) was recommended as the optimal operating condition for the FSC membranes [64]. Table 1 shows some representative facilitated transport membranes that have been reported in the literature. Among them, the polyvinyl amine (PVA_m)-based FSC membranes patented by the Memfo team at NTNU shows the highest CO₂ permeance (up to 5 m³ (STP)/(m²·h·bar)) and CO₂/N₂ (> 500) selectivity under humidified conditions [87]. This membrane is extremely promising for post-combustion CO₂ capture where flue gas is usually water vapor saturated [61, 64, 87]. A pilot flat-sheet FSC membrane system has been tested in EDP's power plant in

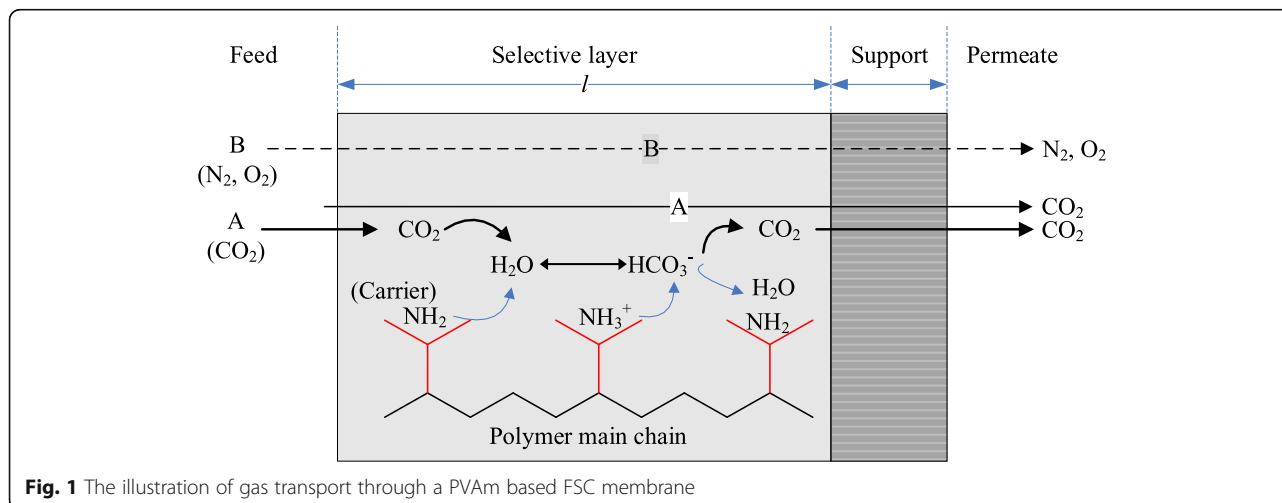

Fig. 1 The illustration of gas transport through a PVAm based FSC membrane

Sines (Portugal) in 2011, and the membranes showed a stable performance over 6 months [52]. Later on, the hollow fiber FSC membranes were tested at Sintef CO₂ lab at Tiller (Norway) with a 9.5% CO₂ contained flue gas produced from a propane burner [74]. They reported that single-stage membrane system (area 8.4 m²) can achieve > 60% permeate CO₂ purity at a feed and permeate pressure of 2 bar and 0.2 bar, respectively, and the system also showed quite fast response when changing feed CO₂ composition. The reported pilot FSC membrane system provided great flexibility on testing the influence of process operating parameters, especially temperature. However, the challenges related to the optimization of module and process should be further investigated. In addition, material development by introducing other support and more effective multi-amines and aminoacids with higher CO₂ reaction kinetics and loading capacity is crucial to further improve membrane performance. Han et al. recently reported a nanotube reinforced 2-(1-piperazinyl) ethylamine sarcosinate blend with PVAm composite membrane with 1451 GPU CO₂ permeance and 165 CO₂/N₂ selectivity at 65 °C [58], which will be very promising if such performance can be achieved in field testing.

Mixed matrix membranes

Rigid permeable or impermeable particles are dispersed in a continuous polymeric phase to form MMMs to present interesting materials for improving separation performance of common polymer membranes [6]. Two types of inorganic fillers can be added into polymer matrix such as microporous fillers (e.g., carbon molecular sieves, zeolite) and nonporous nanoparticles (e.g., SiO₂, TiO₂). MMMs with microporous fillers could improve selectivity based on molecular sieving or surface flow transport mechanism, and it might also get an increased permeability if the preferred solid phase has a higher diffusion coefficient. While MMMs made by adding nonporous nanoparticles can improve gas permeability due to the increase of free volume. Chung et al. [25] reported that the properties for both polymer materials and inorganic fillers could affect the morphology and separation performance of MMMs. The rigid structure glassy polymers with high selectivity are more suitable for polymer matrix compared to rubbery polymers. However, the adhesion between glassy polymer phase and inorganic filler phase is a challenging issue for preparation of MMMs. Moreover, the thermal and chemical stabilities of MMMs are mainly dependent on physical property of a polymer matrix, which may suffer from the acid gases of SO₂ or NO_x that are usually involved in flue gas. MMMs normally present an enhanced mechanical strength compared to pure polymer membranes, and a reduced cost compared to pure inorganic membranes. However, the main challenge for preparation of

MMM is to choose proper materials for both polymeric and inorganic phases to get a high gas separation performance and good compatibility. Examples for selection of polymer and inorganic filler for making CO₂ selective MMMs are reviewed in the literature [76, 149], and only the latest MMM materials are listed in Table 1. Recently, the PIMs/MOF MMMs with CO₂ permeance of 1740 GPU and enhanced selectivity (70%) and mechanical strength were reported by Ghalei et al. [44]; they concluded that membranes can be further optimized for economical CO₂ capture.

Carbon molecular sieve membranes

CMSMs are usually prepared by carbonization of polymeric precursors such as polyimide [10, 141, 142], polyacrylonitrile (PAN) [29], poly(phthalazinone ether sulfone ketone) [163], poly(phenylene oxide) [91, 161], and cellulose derivatives [65, 68, 72, 73, 90, 99]. CMSMs present high mechanical strength and moderate modulus due to their graphitic or turbostratic structure compared to graphitized fibers [130]. The separation mechanism of CMSMs is based on kinetic diameter difference in the gas molecules. CO₂ has a smaller kinetic diameter compared to O₂, N₂, and CH₄. The hollow fiber polyimide derived carbon membranes developed by Georgia Tech have been reported for different types of gas separations (e.g., CO₂/CH₄ and olefin/paraffin [134, 135, 155]). The issues related to high precursor cost and low gas permeance need to be further addressed. The cellulose acetate (CA)-based hollow fiber carbon membranes were developed by NTNU for biogas upgrading, natural gas sweetening, and H₂ separation [47, 53, 54, 97]. The main advantages of this type of carbon membrane are the low cost of CA precursor and the carbonization processability. However, it still has the challenges on (1) keeping deacetylated CA fibers straight during the drying process; (2) increasing gas permeance; and (3) reducing membrane aging due to the pore blockage of water vapor adsorption at relative humidity (RH) > 30%.

Although CMSMs present higher production cost, more challenges on module construction (due to the relatively brittle structures), and significant aging issue compared to most polymeric membranes, the advantages of high gas permeance and selectivity as well as high thermal and chemical stability still encouraged many researchers to develop carbon membranes for gas separation [68, 72, 88, 98, 141, 146, 161]. Considering the future commercial applications, strong effort should be put on the development of high performance asymmetric hollow fiber carbon membranes or tubular ceramic supported carbon membranes. Xu et al. prepared asymmetric hollow fiber carbon membranes for olefin/paraffin and ethylene/ethane separations [156, 157]. The PVDF-based asymmetric hollow fiber carbon membranes were reported for organic liquid separations [89].

Their investigation results showed a promising application of carbon membranes in energy-related processes. Recently, high flux ceramic supported carbon membranes with a high CO₂ permeance of 0.6 m³(STP)/(m²·h·bar) and CO₂/CH₄ selectivity of 30 were developed by Richter et al. [128], which can be potentially used for CO₂ removal from natural gas. However, the membrane cost and upscaling need to be further investigated.

CO₂ capture from power plant

The world fossil fuel power plants emit about two billion tons of CO₂ per year which should be significantly reduced according to the Kyoto protocol. CCS is one of the most promising options for the reduction of CO₂ emissions. Different techniques such as physical absorption (e.g., Selexol, Rectisol), chemical absorption (e.g., MEA, MDEA), physical adsorption (e.g., molecular sieves, metal organic frameworks), and gas separation membranes can be used to CO₂ capture from flue gas in power plants. Among them, amine absorption has been widely used in for CO₂ removal and considered to be the most mature technology. However, conventional amine absorption is an energy-intensive and high-cost process, which results in the large incremental costs of electricity generation. National Energy Technology Laboratory (NETL) estimated that amine unit will increase the cost of electricity production by 70% [38]. As an alternative, gas separation membranes and/or hybrid systems (e.g., membrane contactor, membrane-cryogenic process) for carbon capture, as illustrated in Fig. 2 [73], may have potentials to bring down the CO₂ capture cost in this application.

Gas separation membrane system

Yang et al. reviewed the progress of CO₂ separation using membrane technology, and they concluded that membrane process is energy-saving, space-saving, easy to scale-up, and can be a promising technology for CO₂ separation [158]. Strong effort has been put on the

development of high-performance membranes (high CO₂ permeance and relatively good selectivities over other gas molecules) with good long-term stability for CO₂ capture, and some ultrathin nanocomposite and FSC membranes showed great potentials [16, 17, 50, 70, 77, 78, 107, 124, 139, 140, 158].

The Polaris® membranes developed by MTR has been demonstrated at pilot-scale for CO₂ capture from a natural gas combined cycle power plant [23]. A 20 ton/day skid was tested to validate the advanced modules (multi-tube and plate-and-frame) designed for low-pressure drop and small footprint, and the system showed quite stable performance over ca. 1000 h [106]. Moreover, MTR patented their process by feeding high CO₂ content air stream (air as sweep gas in the permeate side of the 2nd stage membrane unit) into the boiler to increase the CO₂ concentration in the flue gas [9], which can greatly reduce the required membrane area and energy consumption for this application.

It is worth noting that process design is crucial to improve the overall energy efficiency of the whole process with the integration of CO₂ capture unit. Many research work on technology feasibility analysis based on air sweeping process were reported. However, the influences of CO₂-contained air on the boiler operation should be further tested. It is worth noting that gas permeance of Polaris membranes has been significantly improved at lab-scale. Further pilot demonstration (field testing) is required to prove the performance at larger scale.

The large EU project NanoGLOWA (including 27 partners from European companies, universities, institutes and power plants) launched in 2006 was aiming at developing high-performance membranes for CO₂ capture from flue gas in post-combustion power plants. A small pilot-scale plate-and-frame module was installed in EDP's power plant in Sines (Portugal) to test the working of membranes in a real flue gas in 2011, and the membranes showed a stable performance over 6 months [52]. Recently, this type of membrane was

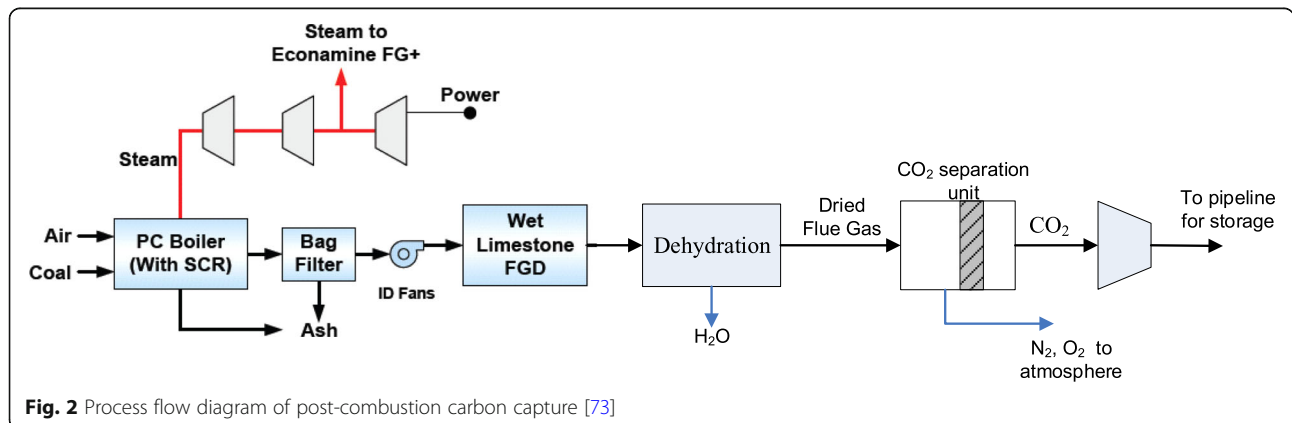

Fig. 2 Process flow diagram of post-combustion carbon capture [73]

demonstrated for CO₂ capture in the real flue gas from a propane burner at SINTEF Tiller plant (Trondheim, Norway) [74] and Norcem cement factory [51]. Two semi-commercial hollow fiber modules coated with PVAm selective layer (membrane area of 8.4 m²) were performed in parallel in a single-stage process. The testing results indicated that a 60 vol% CO₂ purity was achieved in the permeate stream from a feed flue gas with 9.5 vol% CO₂ [74]. In December 2016, Air Products Ltd. licensed the PVAm-based FSC membranes for post-combustion CO₂ capture and will bring the technology to commercialization in the near future [48].

The PolyActive™ membranes developed by Helmholtz-Zentrum Geesthacht were tested for CO₂ capture from real flue gas using a pilot module with a membrane area of 12.5 m² [119]. The membrane system also showed stable performance over 740 h continuously, and they also reported that membrane processes was well suitable for post combustion CO₂ capture, and a CO₂ purity of 68.2 mol% in the permeate and a recovery of 42.7% can be achieved at the tested condition in a single-stage process. A two-stage pilot membrane system should be demonstrated to document the technology feasibility related to the energy consumption and the required membrane area. The engineering challenge on upscaling of envelop module needs to be addressed.

It should be remembered that techno-economic feasibility analysis should be conducted before bringing any type of membranes into commercial application. He et al. investigated the application of hollow fiber carbon membranes for CO₂ capture from flue gas [59]. They reported a capital cost of \$100/tonne CO₂ avoided for carbon membrane system, which was higher than a traditional chemical method of MEA (\$59/tonne CO₂ avoided reported by Rao and Rubin [125]), but the referred carbon membranes had a clear potential of further optimization. Merkel et al. [107] reported that membrane with a CO₂/N₂ selectivity above 50 and a CO₂ permeance of 4000 GPU could offer a capture cost below \$15/tonne CO₂, which is lower than US Department of Energy's (DOE) target goal (\$20/tonne CO₂). They also pointed out that improving membrane permeance is more important than increasing selectivity (if selectivity > 30) to further reduce the cost of CO₂ capture from flue gas [107]. He et al. [64, 70] and Hussain et al. [78] conducted process feasibility analysis by HYSYS integrated with an in-house membrane program (ChemBrane, developed by Grainger [46]) to investigate the influence of process parameters on energy demand and flue gas processing cost using a novel CO₂-selective FSC membrane. Their simulation results showed that membrane process using the high-performance FSC membranes was feasible for CO₂ capture to achieve > 90% CO₂ recovery and high CO₂ purity above 90%, even from a flue gas with a low CO₂ concentration (~ 10%). Ramasubramanian et al. reported a CO₂ capture cost of \$25/tonne CO₂ using an

assumed membrane performance of CO₂ permeance of 3000 GPU (~ 8.2 m³(STP)/(m² h bar)) and CO₂/N₂ selectivity of 140 [124]. More recently, membrane properties required for post-combustion carbon capture were systematically investigated [132, 133], and a permeance of at least 3 m³(STP)/(m² h bar) with high selectivity should be achieved to be competitive to MEA absorption system. Even though the required high-performance membrane has not yet been achieved, their investigations emphasized quantitatively the need of improving the present membrane performance to realize a purely membrane-based process for CO₂ capture. Moreover, the CO₂ capture cost for membrane system is significantly dependent on the required CO₂ capture ratio. It is reported that membrane-based post-combustion CO₂ capture can benefit from lower CO₂ capture ratio with a 55% cost reduction [131], and CO₂ capture ratios lower than 90% would significantly improve the competitiveness of membrane-based carbon capture and lead to large cost reduction [132]. However, the overall benefit should be further investigated through the whole value chain. Therefore, the environmentally friendly technology with further improved membrane performance and properly selected process parameters and separation requirement (especially CO₂ capture ratio) can be a promising candidate for post-combustion CO₂ capture.

Gas-liquid membrane contactor

Membrane contactor combines the advantages of gas separation membrane technology with chemical absorption. In a membrane contactor, the membranes act as an interface between gas and liquid phase (solvent). For post-combustion CO₂ capture, CO₂ transports from the gas phase through microporous and hydrophobic membranes and is absorbed in the liquid phase. The CO₂-loaded liquids are then pumped to the desorber to release CO₂, while the regenerated solvents are recycled back to the membrane contactor [76]. This technology offers a unique way to perform gas-liquid absorption processes and provides a high operational flexibility [34]. Recently, strong interest has been focused on the efficiency studies of the membrane contactors for CO₂ capture [15, 24, 30, 34, 42, 94, 103, 121, 159]. Yeon et al. [159] reported the use of a PVDF hollow fiber membrane contactor for absorption and a stripper column as a desorber for CO₂/N₂ separation, which presented a higher CO₂ removal efficiency than the conventional absorption column. Chabanon et al. studied the wetting resistance of membrane contactors using different membrane materials, and they found that membrane contactors using composite hollow fiber membranes based on either a polymethylpentene (PMP) or a Teflon-AF thin dense layer coated on polypropylene (PP) supports showed remarkably stable performances over time compared to those of PP and polytetrafluoroethylene (PTFE) hollow fibers [24]. Feron et al. have investigated the potential application of CO₂ capture

from flues gas using a membrane contactor composed by porous polypropylene hollow fiber membranes and a dedicated absorption liquid (CORAL) [42]. Their results indicated that membrane contactor could be a promising candidate for CO₂ capture from flue gases in post-combustion power plants. Moreover, Dai et al. [27, 28] reported to use ionic liquid-based membrane contactor for pre-combustion CO₂ capture; the porous PTFE membrane and nonporous Teflon-PP (polypropylene) composite membranes were considered to be the most suitable membranes in this application. Even though the mass transfer resistance increases in membrane contactors particularly when membranes are wetted, the numerous advantages such as significantly increased interfacial area can potentially offset the disadvantages and makes membrane contactors to be promising in CO₂ capture [165].

CO₂ capture from industry

CO₂ emissions from industrial sectors such as steel/iron production, cement factory, and gas production plants contribute more than 10% of total CO₂ emissions. CO₂ removal from natural gas and biogas is mandatory to increase methane purity and avoid pipeline corrosion. Moreover, CCS is the only solution to reduce CO₂ emissions from cement factory as 50% of CO₂ is the by-product of a cement production process. Thus, CO₂ capture from those energy-intensive industries should also be implemented.

CO₂ removal from natural gas

Natural gas (NG) is becoming one of the most attractive growing fuels for world primary energy consumption due to its availability and versatility. NG is a less carbon-intensive and cleaner energy source compared to the other fossil fuels of coal and crude oil. However, raw natural gas in reservoirs or/and wells usually contains considerable amount of light and heavy hydrocarbons (HHCs), as well as the impurities such as water, H₂S, CO₂, N₂, and helium. Natural gas sweetening is mandatory in any natural gas plants to remove the acid gases of H₂S and CO₂ to meet the legal requirements and gas grid specifications. Different technologies such as chemical absorption [83], pressure swing adsorption (PSA) [81, 143], and membranes [2, 12, 43, 62, 63, 66–69, 93, 96] have been reported for CO₂ removal from natural gas. Decision on which technology used for CO₂ removal from natural gas is mainly dependent on process conditions and the raw natural gas composition. Conventional chemical (amine) absorption is well known and implemented in industrial processes, and still considered as the state-of-the-art technology for CO₂ capture. However, membrane systems possess many advantages such as small footprint, low capital, and operating costs are environmentally friendly and exhibit their process flexibility [11], which show a great potential for natural gas sweetening even though it has only a 5% of the market today.

Commercial membranes for natural gas sweetening are usually made from cellulose acetate and polyimide and have a typical CO₂/CH₄ selectivity of 15~30 [13]. Membrane systems are preferred for high CO₂ concentration gas streams (enhanced gas recovery plant, ca. 50% CO₂, and high pressure), and amine units are preferred for relatively low-concentration gas streams. Moreover, membrane systems are also favorable to be used for processing small gas flows because of their simple flow schemes (typically in offshore platforms, < 6000 Nm³/h), while amine units are more complex and require careful, well-monitored operating procedures, as documented by Baker et al. [8]. Although common polymer membranes for natural gas sweetening are still cellulose acetate/triacetate and polyimide, the novel, high-performance FSC membranes and carbon membranes showed nice potentials for CO₂/CH₄ separation [32, 33, 55, 69].

High-pressure operation is one of the most challenging issues related to natural gas sweetening with membrane systems since membrane plasticization and compaction are found to be a well-known phenomenon in most polymer membranes [40, 152]. For the FSC membranes, carrier saturation at a high CO₂ concentration or partial pressure will additionally cause the reductions of CO₂ permeance and CO₂/CH₄ selectivity. The potential strategies to overcome membrane plasticization are cross-linking of membrane material [153] and fabrication of mechanical strong membranes with enhanced properties, e.g., mixed matrix membrane by adding inorganic fillers into the polymer matrix. Adams et al. prepared a 50% (vol.) Zeolite 4A/poly (vinyl acetate) MMM with increase separation performance for CO₂/CH₄ separation [2]. Their results showed a promising application for high-pressure natural gas sweetening. He et al. reported that CNTs reinforced PVAm/PVA blend FSC membrane presented a good CO₂/CH₄ separation performance at high pressure up to 40 bar [62, 63, 67–69], which showed a nice potential application for CO₂ removal from natural gas. There are, however, still challenges to maintain the separation performance at higher pressure > 40 bar (especially > 80 bar in subsea process), which can be potentially addressed by employing high-performance (to exceed the Robeson CO₂/CH₄ upper bound) carbon membranes with high mechanical strength to tolerate high pressure without losing separation performance.

Membrane system design for CO₂ removal from natural gas is mainly dependent on membrane performance, CO₂ concentration in feed stream, specific separation requirement, as well as plant location. Peters et al. conducted process design, simulation, and optimization for CO₂ removal from natural gas using HYSYS integrated with an in-house membrane program (ChemBrane) [118]. They reported that a two-stage membrane system

with a CO₂ permeance of 0.3 m³(STP)/(m² h bar) and a CO₂/CH₄ selectivity of 40 is comparable to that of amine process [118]. Although the purity of sweet gas with membrane system is a little low, it can still achieve the sales gas standards (< 2% CO₂ in natural gas). It was also reported that two-stage membrane systems with a membrane unit cost < \$60/m² membrane area was viable for CO₂ removal from a CO₂ content (10 vol%) natural gas [66]. Moreover, membrane system presents a small footprint and flexibility, and is easy to maintain, which is crucial for subsea and offshore natural gas production. It should be noted that membranes for natural gas sweetening is one of the most promising application related to the market and economic benefit.

CO₂ removal from biogas

Biogas is usually produced from anaerobic digestion of wastes such as sewage sludge, animal manure, and organic fraction of household, which is mainly composed of methane (CH₄) and carbon dioxide (CO₂) and may also contain VOCs, H₂O, H₂S, and NH₃. Biogas has a potential of high energy due to the presence of high purity methane. However, depending on the end usage, a specific biogas treatment (i.e., biogas upgrading, defined as CO₂ removal from raw biogas) should be conducted to increase the calorific value of biogas. Therefore, it is crucial to identify energy-efficient technology for CO₂ removal from biogas at a low CH₄ loss. The common techniques for biogas upgrading include water scrubbing, PSA, chemical absorption (e.g., amines), and gas separation membranes. The selection of suitable technology is mainly dependent on plant condition, such as the availability of low price of thermal energy, electricity and water, as well as the plant capacity. In the European region, water scrubbing is the most prevailing technology at biogas plants (40%), and membrane has 4% of the market today [113]. Most biogas plants in Sweden are using PSA even though CH₄ loss is high (3–10%). The biogas plants using water scrubbing technology can get high purity CH₄ (> 99 vol%), but also produces a lot of wastewater and has high power demands. The amine scrubbing technology presents high selectivity to produce high purity methane, but the process is energy-intensive and environmentally unfriendly due to the needs of organic solvents of amines. Comparing to other state-of-the-art technologies, gas separation membrane processes present more energy- and space-saving and lower environmental impacts and are preferable for small-scale biogas plants < 1000 m³(STP)/h [108]. The commercial SEPURAN® membranes developed by EVO-NIK for biogas upgrading have low-energy requirements and low maintenance costs. The main challenge is to get high CH₄ purity and low CH₄ loss simultaneously. The latest reported single-stage polyimide membrane system

can only reach CH₄ purity of 80.7 vol% with a high CH₄ loss of 24%, which is unacceptable in any biogas production plants [111]. Using a multi-stage membrane system in series can get high purity CH₄, but CH₄ loss will be higher. A CH₄ loss to atmosphere of more than 4% leads to a non-sustainable process according to carbon footprint life cycle assessment [126], which is negative related to economy and environment impact due to the high global warming potential (GWP) of methane. Therefore, seeking a high CO₂/CH₄ selective membrane (at least > 30) is crucial to reduce CH₄ loss, simplify process design, and reduce energy consumption. The cellulose-derived hollow fiber carbon membranes have been reported for CO₂/CH₄ separation and presented a high CO₂/CH₄ selectivity over 100 [53, 72], which showed the potential for CO₂ removal from biogas. The techno-economic feasibility analysis also proved that carbon membrane can be a competitive technology for biogas upgrading compared to amine absorption [60]. Moreover, several carbon membrane modules (each one has the area of 2 m²) were exposed to a real biogas (63 vol% CH₄, 1 ppm H₂S, balance CO₂) over 200 days at a biogas plant in Southern Norway. The biogas with 10 Nm³/h was fed into these modules at 20 bar. A high purity methane of 96 vol% and a CH₄ recovery of 98% was achieved [56], and the membranes showed stable performance over the testing period, which is considered at TRL 5. Although the reported pilot system can produce high purity biomethane as vehicle fuels, there are still challenges related to uniform packing of hollow fiber carbon membranes. Moreover, the brittleness of hollow fibers remained a challenge for module upscaling. Future researches should focus on improving mechanical properties and gas permeance, which directs to the development of asymmetric flexible hollow fiber carbon membranes or supported carbon membranes.

CO₂ capture from cement factory

Cement factory is pursuing solutions for carbon capture from high CO₂ content flue gas (ca. 17 vol% wet base) as it represents 7% of global anthropogenic CO₂ emissions. Application of CO₂ capture in cement kilns would have great potential to reduce CO₂ emission from these industries but will naturally influence cement production cost. Thus, the European cement industry (through HeidelbergCement) is taking big interest in low-cost CO₂ capture technologies.

Cement factory releases greenhouse gas emissions both directly and indirectly: limestone calcination directly releases ~ 50% of all CO₂ emissions in the cement production, while the burning of fuels to heat the kiln indirectly contributes another 50% CO₂ emissions. Employment of CCS is considered as one of the most important techniques to achieve the Norcem Zero CO₂ Emission Vision 2030. Three different technologies (amine absorption,

membranes, solid adsorbent) were tested on site to document the process feasibility [14]. There, the first pilot-scale membrane system using PVAm-based flat-sheet FSC membranes was tested for CO₂ capture from a 17 vol% (wet base) CO₂ flue gas in cement factory. Although many challenges related to process and module design were revealed, and it was also difficult to achieve a stable operation of membrane system, a CO₂ purity up to 72% was achieved for short periods when all process parameters were well controlled in the single-stage FSC membrane system [49]. The membrane efficiency of the plate-and-frame module was quite low, and the designed system suffered significant water condensation/corrosion issues. Thus, the hollow fiber FSC membrane modules with total membrane area of ca. 20 m² were constructed by the joint force from Air Products and Chemicals, Inc., in 2016 [51]. In that project, the pilot FSC membrane system was evaluated at TRL 5. The system was tested over 6 months at different conditions, and stable performance was found even at a high NO_x and SO₂ loading (average 100 ppm and 5 ppm, respectively) flue gas. They reported that stable permeate CO₂ purity of 65% over the accumulated 24 days was achieved. The techno-economic feasibility analysis was also reported to achieve 80% CO₂ recovery and > 90% CO₂ purity. However, the designed two-stage membrane system was difficult to achieve specific CO₂ purity (> 95%) requirement (especially the low O₂ limitation) for enhanced oil/gas recovery (EOR/EGR). The potential solutions are to introduce a third-stage membrane unit or a low-temperature liquefaction unit. It should also be remembered that proper pre-treatment processes (e.g., particle filtering, water condensation) are always required to protect membrane system for CO₂ capture in cement factory.

CO₂ capture from iron/steel making industry

Recently, CO₂ capture from power generation has received a lot of attention as described in the section “CO₂ capture from power plant”. However, only a few studies reported on CO₂ capture in iron/steel manufacture industries [39, 45, 100, 150]. The previous large European projects, Ultra Low CO₂ Steelmaking (ULCOS) focused on the development of new steel production technology that could drastically cut CO₂ emissions to 50% by the year 2030 (base year 2004), and membrane system was chosen for investigation of CO₂ capture from nitrogen free blast furnace (NFBF) exhaust gases (N₂/CO₂/CO/H₂: 10%/36%/47%/7%). Lie et al. reported that PVAm/PVA blend FSC membranes can become a potential candidate for CO₂ capture from flue gas in steelmaking industry with 15.0–17.5 €/tonnes CO₂ [100]. Recently, Roussanaly et al. reported on the simulation of different membranes for CO₂ capture from steel industry with a 30%CO₂ in feed gas, and a relatively

low CO₂ capture cost was identified compared to carbon capture in other processes [131]. However, it should be noted that the feed gas only contains CO₂ and N₂ in their study, while CO, H₂ are neglected which usually existed. Thus, further investigation with more accurate feed gas composition should be conducted to document the economic feasibility.

Future perspectives

The deployment of CO₂ capture in power plants and process industries is crucial to reduce CO₂ emissions, and several technologies should be alternatively employed depending on flue gas composition, plant location, and separation requirement. Amine absorption is still considered as the most mature technology today for large- or full-scale applications and developing next generation advanced solvents should be pursued to reduce energy consumption. Gas separation membranes, especially ultrathin polymeric and FSC membranes, for post-combustion CO₂ capture were demonstrated at pilot-scale with stable performance over long-term period and considered as the most technology regarding to the environmental impact and energy efficiency. However, membrane performance should be further improved to reduce CO₂ capture cost down to \$20/tonne CO₂. Moreover, process design need to be carefully considered to make a right choice, and a two/multi-stage system is usually required to achieve high CO₂ capture ratio and CO₂ purity simultaneously. Nevertheless, membrane systems, which require no chemicals, are easy to scale up and have a relatively low-energy demand and could be an environmentally friendly technology for CO₂ capture from power plants and other energy-intensive process industries in the future.

Acknowledgements

The author is grateful to the anonymous reviewers for their helpful comments and suggestions.

Funding

The work was supported by the CO2Hing project (#267615) of the Research Council of Norway (Norges forskningsråd).

Availability of data and materials

Data sharing is not applicable to this article as no datasets were generated or analyzed during the current study.

Author's contribution

The author wrote, read, and approved the final manuscript.

Competing interests

The author declares that he has no competing interests.

Publisher's Note

Springer Nature remains neutral with regard to jurisdictional claims in published maps and institutional affiliations.

Received: 23 July 2018 Accepted: 17 October 2018

Published online: 01 November 2018

References

- Abanades JC, Akai M, Benson S, al, et al. (2005) IPCC Special Report Carbon Dioxide Capture and Storage: Summary for Policymakers. http://www.ipcc.ch/pdf/special-reports/srccs/srccs_summaryforpolicymakers.pdf. Accessed 12 Sept 2018.
- Adams RT, Lee JS, Bae T-H, Ward JK, Johnson JR, Jones CW, Nair S, Koros WJ (2011) CO₂-CH₄ permeation in high zeolite 4A loading mixed matrix membranes. *J Membr Sci* 367(1–2):197–203
- Ahmad J, Hägg M-B (2013) Preparation and characterization of polyvinyl acetate/zeolite 4A mixed matrix membrane for gas separation. *J Membr Sci* 427(0):73–84
- Ahmad J, Hägg MB (2013) Polyvinyl acetate/titanium dioxide nanocomposite membranes for gas separation. *J Membr Sci* 445:200–210
- Ahn J, Chung W-J, Pinnau I, Song J, Du N, Robertson GP, Guiver MD (2010) Gas transport behavior of mixed-matrix membranes composed of silica nanoparticles in a polymer of intrinsic microporosity (PIM-1). *J Membr Sci* 346(2):280–287
- Aroon MA, Ismail AF, Matsuura T, Montazer-Rahmati MM (2010) Performance studies of mixed matrix membranes for gas separation: a review. *Sep Purif Technol* 75(3):229–242
- Baker R (2004) Membrane technology and applications, 2nd edn. McGraw-Hill Wiley. <https://doi.org/10.1002/0470020393>
- Baker RW, Lokhandwala K (2008) Natural gas processing with membranes: an overview. *Ind Eng Chem Res* 47(7):2109–2121
- Baker RW, Wijmans JG, Merkel TC, Lin H, Daniels R, Thompson S (2009) Gas separation process using membranes with permeate sweep to remove CO₂ from combustion gases Membrane Technology & Research, Inc, US
- Barsema JN, van der Vegt NFA, Koops GH, Wessling M (2005) Ag-functionalized carbon molecular-sieve membranes based on polyelectrolyte/polyimide blend precursors. *Adv Funct Mater* 15(1):69–75
- Bernardo P, Drioli E (2010) Membrane gas separation progresses for process intensification strategy in the petrochemical industry. *Petrol Chem* 50(4): 271–282
- Bhide BD, Stern SA (1993) Membrane processes for the removal of acid gases from natural gas. II. Effects of operating conditions, economic parameters, and membrane properties. *J Membr Sci* 81(3):239–252
- Bhide BD, Voskericyan A, Stern SA (1998) Hybrid processes for the removal of acid gases from natural gas. *J Membr Sci* 140(1):27–49
- Bjerge L-M, Brevik P (2014) CO₂ capture in the cement industry, Norcem CO₂ capture project (Norway). *Energy Procedia* 63:6455–6463
- Bottino A, Capannelli G, Comite A, Di Felice R, Firpo R (2008) CO₂ removal from a gas stream by membrane contactor. *Sep Purif Technol* 59(1):85–90
- Bredesen R, Jordal K, Bolland O (2004) High-temperature membranes in power generation with CO₂ capture. *Chem Eng Process* 43(9):1129–1158
- Brunetti A, Scura F, Barbieri G, Drioli E (2010) Membrane technologies for CO₂ separation. *J Membr Sci* 359(1–2):115–125
- Budd PM, Elabas ES, Ghanem BS, Makhsed S, McKeown NB, Msayib KJ, Tattershall CE, Wang D (2004) Solution-processed, organophilic membrane derived from a polymer of intrinsic microporosity. *Adv Mater* 16(5):456–459
- Budd PM, McKeown NB, Ghanem BS, Msayib KJ, Fritsch D, Starannikova L, Belov N, Sanfirova O, Yampolskii Y, Shantarovich V (2008) Gas permeation parameters and other physicochemical properties of a polymer of intrinsic microporosity: Polybenzodioxane PIM-1. *J Membr Sci* 325(2):851–860
- Budd PM, Msayib KJ, Tattershall CE, Ghanem BS, Reynolds KJ, McKeown NB, Fritsch D (2005) Gas separation membranes from polymers of intrinsic microporosity. *J Membr Sci* 251(1–2):263–269
- Bushell AF, Attfield MP, Mason CR, Budd PM, Yampolskii Y, Starannikova L, Rebrov A, Bazzarelli F, Bernardo P, Carolus Jansen J, Lanč M, Friess K, Shantarovich V, Gustov V, Isaeva V (2013) Gas permeation parameters of mixed matrix membranes based on the polymer of intrinsic microporosity PIM-1 and the zeolitic imidazolate framework ZIF-8. *J Membr Sci* 427(0):48–62
- Carapellucci R, Milazzo A (2003) Membrane systems for CO₂ capture and their integration with gas turbine plants Proceedings of the Institution of Mechanical Engineers, Part A. *J Power Energy* 217(5):505–517
- Casillas, C., Chan, K., Fulton, D., Kaschemekat, J., Kniep, J., Ly, J., Merkel, T., Nguyen, V., Sun, Z., Wang, X., Wei, X., White, S., 2015. Pilot testing of a membrane system for post-combustion CO₂ capture, NETL CO₂ capture technology meeting Pittsburgh
- Chabanon E, Roizard D, Favre E (2011) Membrane contactors for Postcombustion carbon dioxide capture: a comparative study of wetting resistance on long time scales. *Ind Eng Chem Res* 50(13):8237–8244
- Chung T-S, Jiang LY, Li Y, Kulprathipanja S (2007) Mixed matrix membranes (MMMs) comprising organic polymers with dispersed inorganic fillers for gas separation. *Prog Polym Sci* 32(4):483–507
- D'Alessandro DM, Smit B, Long JR (2010) Carbon dioxide capture: prospects for new materials. *Angew Chem Int Ed* 49(35):6058–6082
- Dai Z, Ansaloni L, Deng L (2016a) Precombustion CO₂ capture in polymeric hollow fiber membrane contactors using ionic liquids: porous membrane versus nonporous composite membrane. *Ind Eng Chem Res* 55(20):5983–5992
- Dai Z, Noble RD, Gin DL, Zhang X, Deng L (2016b) Combination of ionic liquids with membrane technology: a new approach for CO₂ separation. *J Membr Sci* 497:1–20
- Djordjevic LB, Ismail AF (2003) Influence of the thermostabilization process and soak time during pyrolysis process on the polyacrylonitrile carbon membranes for O₂/N₂ separation. *J Membr Sci* 213(1–2):285–291
- deMontigny D, Tontiwachwuthikul P, Chakma A (2006) Using polypropylene and polytetrafluoroethylene membranes in a membrane contactor for CO₂ absorption. *J Membr Sci* 277(1–2):99–107
- Deng L (2009) Development of novel PVAm/PVA blend FSC membrane for CO₂ capture. Norwegian University of Science and Technology, Trondheim
- Deng L, Kim T-J, Hägg M-B (2009a) Facilitated transport of CO₂ in novel PVAm/PVA blend membrane. *J Membr Sci* 340(1–2):154–163
- Deng L, Kim T-J, Sandru M, Hägg M-B (2009b) PVA/PVAm blend FSC membrane for natural gas sweetening. Proceedings of the 1st annual gas processing symposium, Doha, pp 247–255
- Dindore VY, Brilman DWF, Feron PHM, Versteeg GF (2004) CO₂ absorption at elevated pressures using a hollow fiber membrane contactor. *J Membr Sci* 235(1–2):99–109
- Do YS, Lee WH, Seong JG, Kim JS, Wang HH, Doherty CM, Hill AJ, Lee YM (2016) Thermally rearranged (TR) bismaleimide-based network polymers for gas separation membranes. *Chem Commun* 52(93):13556–13559
- Du N, Park HB, Robertson GP, Dal-Cin MM, Visser T, Scoles L, Guiver MD (2011) Polymer nanosieve membranes for CO₂-capture applications. *Nat Mater* 10(5):372–375
- Duan S, Taniguchi I, Kai T, Kazama S (2012) Poly(amidoamine) dendrimer/poly(vinyl alcohol) hybrid membranes for CO₂ capture. *J Membr Sci* 423–424(0):107–112
- Elwell, LC., Grant, W.S., 2006. Technology options for capturing CO₂. http://www.powermag.com/coal/Technology-options-for-capturing-CO2_582.html. Accessed 12 Sept 2018
- Farla JC, Hendriks CA, Blok K (1995) Carbon dioxide recovery from industrial processes. *Clim Chang* 24:439–461
- Favre E (2011) Membrane processes and postcombustion carbon dioxide capture: challenges and prospects. *Chem Eng J* 171(3):782–793
- Favvas EP, Katsaros FK, Papageorgiou SK, Sapalidis AA, Mitropoulos AC (2017) A review of the latest development of polyimide based membranes for CO₂ separations. *React Funct Polym* 120:104–130
- Feron PHM, Jansen AE (2002) CO₂ separation with polyolefin membrane contactors and dedicated absorption liquids: performances and prospects. *Sep Purif Technol* 27(3):231–242
- Freeman B, Yampolskii Y (2010) Membrane gas separation. Wiley, Hoboken
- Ghalei B, Sakurai K, Kinoshita Y, Wakimoto K, Isfahani AP, Song Q, Doitomi K, Furukawa S, Hirao H, Kusuda H, Kitagawa S, Sivaniah E (2017) Enhanced selectivity in mixed matrix membranes for CO₂ capture through efficient dispersion of amine-functionalized MOF nanoparticles. *Nature Energy* 2:17086
- Gielen D (2003) CO₂ removal in the iron and steel industry. *Energy Convers Manag* 44(7):1027–1037
- Grainger, D., 2007. Development of carbon membranes for hydrogen recovery, Department of Chemical Engineering Norwegian University of Science and Technology, Trondheim
- Grainger D, Hägg M-B (2007) Evaluation of cellulose-derived carbon molecular sieve membranes for hydrogen separation from light hydrocarbons. *J Membr Sci* 306(1–2):307–317
- Hägg MB (2017) One step closer to bringing CO₂ capture technology to the marketplace https://www.eurekalert.org/pub_releases/2017-01/nuos-osc011117.php. Accessed 12 Sept 2018.

49. Hägg M-B, He X, Sarfaraz V, Sandru M, Kim T-J (2015) CO₂ capture using a membrane pilot process at cement factory, in Brevik Norway- lessons learnt. The 8th Trondheim CCS conference (TCCS8), Trondheim
50. Hagg MB, Lindbräthen A (2005) CO₂ capture from natural gas fired power plants by using membrane technology. *Ind Eng Chem Res* 44(20):7668–7675
51. Hägg MB, Lindbräthen A, He X, Nodeland SG, Cantero T (2017) Pilot demonstration-reporting on CO₂ capture from a cement plant using hollow Fiber process. *Energy Procedia* 114:6150–6165
52. Hägg MB, Sandru M, Kim TJ, Capala W, Huijbers M (2012) Report on pilot scale testing and further development of a facilitated transport membrane for CO₂ capture from power plants. Euromembrane, London
53. Haider S, Lindbräthen A, Hägg M-B (2016) Techno-economical evaluation of membrane based biogas upgrading system: a comparison between polymeric membrane and carbon membrane technology. *Green Energy Environ* 1(3):222–234
54. Haider S, Lindbräthen A, Lie JA, Andersen ICT, Hägg M-B (2017) CO₂ separation with carbon membranes in high pressure and elevated temperature applications. *Sep Purif Technol* 52(2):156–116
55. Haider S, Lindbräthen A, Lie JA, Andersen ICT, Hägg M-B (2018a) CO₂ separation with carbon membranes in high pressure and elevated temperature applications. *Sep Purif Technol* 190:177–189
56. Haider S, Lindbräthen A, Lie JA, Carstensen PV, Johannessen T, Hägg M-B (2018b) Vehicle fuel from biogas with carbon membranes; a comparison between simulation predictions and actual field demonstration. *Green Energy Environ* 3(3):266–276
57. Han SH, Kwon HJ, Kim KY, Seong JG, Park CH, Kim S, Doherty CM, Thornton AW, Hill AJ, Lozano AE, Berchtold KA, Lee YM (2012) Tuning microcavities in thermally rearranged polymer membranes for CO₂ capture. *Phys Chem Chem Phys* 14(13):4365–4373
58. Han Y, Wu D, Ho WSW (2018) Nanotube-reinforced facilitated transport membrane for CO₂/N₂ separation with vacuum operation. *J Membr Sci*. <https://doi.org/10.1016/j.memsci.2018.08.061>
59. He X, 2011. Development of hollow fiber carbon membranes for CO₂ separation. Department of Chemical Engineering Norwegian University of Science and Technology, Trondheim
60. He X, Chu Y, Lindbräthen A, Hillestad M, Hägg M-B (2018) Carbon molecular sieve membranes for biogas upgrading: techno-economic feasibility analysis. *J Clean Prod* 194:584–593
61. He X, Fu C, Hägg M-B (2015) Membrane system design and process feasibility analysis for CO₂ capture from flue gas with a fixed-site-carrier membrane. *Chem Eng J* 268(0):1–9
62. He X, Hägg M-B (2012c) Membranes for environmentally friendly energy processes. *Membranes* 2(4):706–726
63. He X, Hägg M-B (2012d) Structural, kinetic and performance characterization of hollow fiber carbon membranes. *J Membr Sci* 390–391(0):23–31
64. He X, Hägg M-B (2014) Energy efficient process for CO₂ capture from flue gas with novel fixed-site-carrier membranes. *Energy Procedia* 63(0):174–185
65. He X, Hägg M-B (2011) Optimization of carbonization process for preparation of high performance hollow fiber carbon membranes. *Ind Eng Chem Res* 50(13):8065–8072
66. He X, Hägg M-B, Kim T-J (2014a) Hybrid FSC membrane for CO₂ removal from natural gas: experimental, process simulation, and economic feasibility analysis. *AIChE J* 60(12):4174–4184
67. He X, Hägg MB (2012a) Hybrid fixed-site-carrier membranes for CO₂/CH₄ separation. Euromembrane 2012. UK, London
68. He X, Hägg MB (2012b) Hybrid fixed-site-carrier membranes for CO₂/CH₄ separation. *Proc Eng* 44(0):118–119
69. He X, Kim T-J, Hägg M-B (2014b) Hybrid fixed-site-carrier membranes for CO₂ removal from high pressure natural gas: membrane optimization and process condition investigation. *J Membr Sci* 470(0):266–274
70. He X, Kim T-J, Hägg MB (2013) CO₂ capture with membranes: process design and feasibility analysis, TCCS-7. Trondheim, Norway
71. He X, Kim T-J, Uddin MW, Hägg M-B (2013a) CO₂ Removal from High Pressure Natural Gas with Hybrid Fixed-site-carrier Membranes: Membrane Material Development. AIChE Annual Meeting 2013, San Francisco
72. He X, Lie JA, Sheridan E, Hagg M-B (2011) Preparation and characterization of hollow Fiber carbon membranes from cellulose acetate precursors. *Ind Eng Chem Res* 50(4):2080–2087
73. He X, Lie JA, Sheridan E, Hägg M-B (2009) CO₂ capture by hollow fibre carbon membranes: experiments and process simulations. *Energy Procedia* 1(1):261–268
74. He X, Lindbräthen A, Kim T-J, Hägg M-B (2017a) Pilot testing on fixed-site-carrier membranes for CO₂ capture from flue gas. *IJGGC* 64:323–332
75. He X, Nieto DR, Lindbräthen A, Hägg M-B (2017b) Membrane system design for CO₂ capture, process systems and materials for CO₂ capture. Wiley, pp 249–281
76. He X, Yu Q, Hägg M-B (2013b) CO₂ Capture. In: Hoek EMV, Tarabara WV, editors. *Encyclopedia of Membrane Science and Technology*. Wiley
77. Huang J, Zou J, Ho WSW (2008) Carbon dioxide capture using a CO₂-selective facilitated transport membrane. *Ind Eng Chem Res* 47(4):1261–1267
78. Hussain A, Hägg M-B (2010) A feasibility study of CO₂ capture from flue gas by a facilitated transport membrane. *J Membr Sci* 359(1–2):140–148
79. International Energy Outlook 2011. https://www.iea.org/publications/freepublications/publication/WEO2011_WEB.pdf. Accessed 30 Aug 2018.
80. Jahan Z, Niazi MBK, Hägg M-B, Gregersen ØW (2018) Cellulose nanocrystal/PVA nanocomposite membranes for CO₂/CH₄ separation at high pressure. *J Membr Sci* 554:275–281
81. Keefer, B, Doman, D., 2000. Flow regulated pressure swing adsorption system. WO/1997/039821, US
82. Khan MM, Filiz V, Bengtson G, Shishatskiy S, Rahman MM, Lillepaerg J, Abetz V (2013) Enhanced gas permeability by fabricating mixed matrix membranes of functionalized multiwalled carbon nanotubes and polymers of intrinsic microporosity (PIM). *J Membr Sci* 436(0):109–120
83. Kidnay AJ, Parrish W (2006) *Fundamentals of natural gas processing*. CRC Press, Boca Raton
84. Kim S, Han SH, Lee YM (2012) Thermally rearranged (TR) polybenzoxazole hollow fiber membranes for CO₂ capture. *J Membr Sci* 403–404(0):169–178
85. Kim S, Lee Y (2012) Thermally rearranged (TR) polymer membranes with nanoengineered cavities tuned for CO₂ separation. *J Nanopart Res* 14(7):1–11
86. Kim T-J, Li B, Hägg M-B (2004) Novel fixed-site-carrier polyvinylamine membrane for carbon dioxide capture. *J Polym Sci B Polym Phys* 42(23):4326–4336
87. Kim T-J, Vrålstad H, Sandru M, Hägg M-B (2013) Separation performance of PVAm composite membrane for CO₂ capture at various pH levels. *J Membr Sci* 428(0):218–224
88. Kiyono M, Williams PJ, Koros WJ (2010) Effect of pyrolysis atmosphere on separation performance of carbon molecular sieve membranes. *J Membr Sci* 359(1–2):2–10
89. Koh D-Y, McCool BA, Deckman HW, Lively RP (2016) Reverse osmosis molecular differentiation of organic liquids using carbon molecular sieve membranes. *Science* 353(6301):804–807
90. Koresh JE, Soffer A (1983) Molecular sieve carbon membrane part I: presentation of a new device for gas mixture separation. *Separ Sci Technol* 18:723–734
91. Lee H-J, Suda H, Haraya K, Moon S-H (2007) Gas permeation properties of carbon molecular sieving membranes derived from the polymer blend of polyphenylene oxide (PPO)/polyvinylpyrrolidone (PVP). *J Membr Sci* 296(1–2):139–146
92. Lee S, Binns M, Lee JH, Moon J-H, Yeo J-g, Yeo Y-K, Lee YM, Kim J-K (2017) Membrane separation process for CO₂ capture from mixed gases using TR and XTR hollow fiber membranes: process modeling and experiments. *J Membr Sci* 541:224–234
93. Li F, Li Y, Chung T-S, Kawi S (2010a) Facilitated transport by hybrid POSS*-Matrimid*-Zn²⁺ nanocomposite membranes for the separation of natural gas. *J Membr Sci* 356(1–2):14–21
94. Li J-L, Chen B-H (2005) Review of CO₂ absorption using chemical solvents in hollow fiber membrane contactors. *Sep Purif Technol* 41(2):109–122
95. Li J, Zhang H, Gao Z, Fu J, Ao W, Dai J (2017) CO₂ capture with chemical looping combustion of gaseous fuels: an overview. *Energy Fuel* 31(4):3475–3524
96. Li S, Carreon MA, Zhang Y, Funke HH, Noble RD, Falconer JL (2010b) Scale-up of SAPO-34 membranes for CO₂/CH₄ separation. *J Membr Sci* 352(1–2):7–13
97. Lie, J.A., 2005. Synthesis, performance and regeneration of carbon membranes for biogas upgrading-a future energy carrier, Department of Chemical Engineering Norwegian University of Science and technology, Trondheim
98. Lie JA, Hagg M-B (2005) Carbon membranes from cellulose and metal loaded cellulose. *Carbon* 43(12):2600–2607
99. Lie JA, Hagg M-B (2006) Carbon membranes from cellulose: synthesis, performance and regeneration. *J Membr Sci* 284(1–2):79–86
100. Lie JA, Vassbotn T, Hägg M-B, Grainger D, Kim T-J, Mejdell T (2007) Optimization of a membrane process for CO₂ capture in the steelmaking industry. *IJGGC* 1:309–317

101. Lin H, Freeman BD (2005) Materials selection guidelines for membranes that remove CO₂ from gas mixtures. *J Mol Struct* 739(1–3):57–74
102. Luis P, Neves LA, Afonso CAM, Coelho IM, Crespo JG, Gareia A, Irbien A (2009) Facilitated transport of CO₂ and SO₂ through supported ionic liquid membranes (SILMs). *Desalination* 245(1–3):485–493
103. Mansourizadeh A, Ismail AF (2009) Hollow fiber gas–liquid membrane contactors for acid gas capture: a review. *J Hazard Mater* 171(1–3):38–53
104. McKeown NB (2012) Polymers of intrinsic microporosity. *ISRN Mater Sci* 2012:16
105. McKeown NB, Budd PM, Msayib KJ, Ghanem BS, Kingston HJ, Tattershall CE, Makhseed S, Reynolds KJ, Fritsch D (2005) Polymers of intrinsic microporosity (PIMs): bridging the void between microporous and polymeric materials. *Chem Eur J* 11(9):2610–2620
106. Merkel T, 2016. PILOT TESTING OF A MEMBRANE SYSTEM FOR POST-COMBUSTION CO₂ CAPTURE-Final report. <https://www.osti.gov/scitech/servlets/purl/1337555>. (Accessed 1 July 2018)
107. Merkel TC, Lin H, Wei X, Baker R (2010) Power plant post-combustion carbon dioxide capture: an opportunity for membranes. *J Membr Sci* 359(1–2):126–139
108. Miltner M, Makaruk A, Harasek M (2017) Review on available biogas upgrading technologies and innovations towards advanced solutions. *J Clean Prod* 161:1329–1337
109. Morisato A, Shen HC, Sankar SS, Freeman BD, Pinnau I, Casillas CG (1996) Polymer characterization and gas permeability of poly(1-trimethylsilyl-1-propyne) [PTMSP], poly(1-phenyl-1-propyne) [PPP], and PTMSP/PPP blends. *J Polym Sci B Polym Phys* 34(13):2209–2222
110. Myers C, Pennline H, Luebke D, Ilconich J, Dixon JK, Maginn EJ, Brennecke JF (2008) High temperature separation of carbon dioxide/hydrogen mixtures using facilitated supported ionic liquid membranes. *J Membr Sci* 322(1):28–31
111. Nemestóthy N, Bakonyi P, Szentgyörgyi E, Kumar G, Nguyen DD, Chang SW, Kim S-H, Bélafi-Bakó K (2018) Evaluation of a membrane permeation system for biogas upgrading using model and real gaseous mixtures: the effect of operating conditions on separation behaviour, methane recovery and process stability. *J Clean Prod* 185:44–51
112. Neves LA, Nemestóthy N, Alves VD, Cserjési P, Bélafi-Bakó K, Coelho IM (2009) Separation of biohydrogen by supported ionic liquid membranes. *Desalination* 240(1–3):311–315
113. Niesner J, Jecha D, Stehlik P (2013) Biogas upgrading techniques: state of art review in european region. *Chem Eng Trans* 35:517–522
114. Pan X, Zhang J, Xue Q, Li X, Ding D, Zhu L, Guo T (2017) Mixed matrix membranes with excellent CO₂ capture induced by Nano-carbon hybrids. *ChemNanoMat* 3(8):560–568
115. Park HB, Han SH, Jung CH, Lee YM, Hill AJ (2010) Thermally rearranged (TR) polymer membranes for CO₂ separation. *J Membr Sci* 359(1–2):11–24
116. Park HB, Jung CH, Lee YM, Hill AJ, Pas SJ, Mudie ST, Van Wagner E, Freeman BD, Cookson DJ (2007) Polymers with cavities tuned for fast selective transport of small molecules and ions. *Science* 318(5848):254–258
117. Paul DR, Jampol'skij JP (1994) Polymeric gas separation membranes. CRC Press, Boca Raton Fla
118. Peters L, Hussain A, Follmann M, Melin T, Hägg MB (2011) CO₂ removal from natural gas by employing amine absorption and membrane technology—a technical and economical analysis. *Chem Eng J* 172(2–3):952–960
119. Pohlmann J, Bram M, Wilkner K, Brinkmann T (2016) Pilot scale separation of CO₂ from power plant flue gases by membrane technology. *IJGGC* 53:56–64
120. Pope DS, Koros WJ, Hopfenberg HB (1994) Sorption and dilation of poly(1-(trimethylsilyl)-1-propyne) by carbon dioxide and methane. *Macromolecules* 27(20):5839–5844
121. Qi Z, Cussler EL (1985) Microporous hollow fibers for gas absorption I Mass transfer in the liquid. *J Membr Sci* 23(3):321–332
122. Quan S, Li SW, Xiao YC, Shao L (2017) CO₂-selective mixed matrix membranes (MMMs) containing graphene oxide (GO) for enhancing sustainable CO₂ capture. *IJGGC* 56:22–29
123. Ramasubramanian K, Ho WSW (2011) Recent developments on membranes for post-combustion carbon capture. *Curr Opin Chem Eng* 1(1):47–54
124. Ramasubramanian K, Verweij H, Winston Ho WS (2012) Membrane processes for carbon capture from coal-fired power plant flue gas: a modeling and cost study. *J Membr Sci* 421–422(0):299–310
125. Rao AB, Rubin ES (2002) A technical, economic, and environmental assessment of amine-based CO₂ capture technology for power plant greenhouse gas control. *Environ Sci Technol* 36(20):4467–4475
126. Ravina M, Genon G (2015) Global and local emissions of a biogas plant considering the production of biomethane as an alternative end-use solution. *J Clean Prod* 102:115–126
127. Reijerkerk SR (2010) Polyether based block copolymer membranes for CO₂ separation [PhD]. University of Twente, Enschede, p 245
128. Richter H, Voss H, Kaltenborn N, Kämnitz S, Wollbrink A, Feldhoff A, Caro J, Roitsch S, Voigt I (2017) High-flux carbon molecular sieve membranes for gas separation. *Angew Chem Int Ed* 56(27):7760–7763
129. Robeson LM (2008) The upper bound revisited. *J Membr Sci* 320(1–2):390–400
130. Rodríguez-Reinoso F, Marsh H (2000) Sciences of carbon materials. Universidad de Alicante, Alicante
131. Roussanaly S, Anantharaman R (2017) Cost-optimal CO₂ capture ratio for membrane-based capture from different CO₂ sources. *Chem Eng J* 327:618–628
132. Roussanaly S, Anantharaman R, Lindqvist K, Hagen B (2018) A new approach to the identification of high-potential materials for cost-efficient membrane-based post-combustion CO₂ capture. *Sustainable Energy Fuels* 2(6):1225–1243
133. Roussanaly S, Anantharaman R, Lindqvist K, Zhai H, Rubin E (2016) Membrane properties required for post-combustion CO₂ capture at coal-fired power plants. *J Membr Sci* 511:250–264
134. Rungta M, Wenz GB, Zhang C, Xu L, Qiu W, Adams JS, Koros WJ (2017) Carbon molecular sieve structure development and membrane performance relationships. *Carbon* 115:237–248
135. Rungta M, Xu L, Koros WJ (2012) Carbon molecular sieve dense film membranes derived from Matrimid® for ethylene/ethane separation. *Carbon* 50(4):1488–1502
136. Samanta A, Zhao A, Shimizu GKH, Sarkar P, Gupta R (2011) Post-combustion CO₂ capture using solid sorbents: a review. *Ind Eng Chem Res* 51(4):1438–1463
137. Sandru M, Haukeba SH, Hägg M-B (2010) Composite hollow fiber membranes for CO₂ capture. *J Membr Sci* 346(1):172–186
138. Sandru M, Kim T-J, Capala W, Huijbers M, Hägg M-B (2013) Pilot scale testing of polymeric membranes for CO₂ capture from coal fired power plants. *Energy Procedia* 37:6473–6480
139. Scholes CA, Ho MT, Wiley DE, Stevens GW, Kentish SE (2013) Cost competitive membrane—cryogenic post-combustion carbon capture. *IJGGC* 17(0):341–348
140. Shao P, Dal-Cin MM, Guiver MD, Kumar A (2013) Simulation of membrane-based CO₂ capture in a coal-fired power plant. *J Membr Sci* 427(0):451–459
141. Steel KM, Koros WJ (2003) Investigation of porosity of carbon materials and related effects on gas separation properties. *Carbon* 41(2):253–266
142. Suda H, Haraya K (1997) Gas permeation through micropores of carbon molecular sieve membranes derived from Kapton polyimide. *J Phys Chem B* 101(20):3988–3994
143. Tagliabue M, Rizzo C, Onorati NB, Gambarotta EF, Carati A, Bazzano F (2012) Regenerability of zeolites as adsorbents for natural gas sweetening: a case-study. *Fuel* 93(0):238–244
144. Thomas S, Pinnau I, Du N, Guiver MD (2009) Pure- and mixed-gas permeation properties of a microporous spirobisindane-based ladder polymer (PIM-1). *J Membr Sci* 333(1–2):125–131
145. Tong Z, Ho WSW (2017) Facilitated transport membranes for CO₂ separation and capture. *Separ Sci Technol* 52(2):156–167
146. Tseng H-H, Itta AK (2012) Modification of carbon molecular sieve membrane structure by self-assisted deposition carbon segment for gas separation. *J Membr Sci* 389(0):223–233
147. Uddin MW, Hägg M-B (2012a) Effect of monoethylene glycol and triethylene glycol contamination on CO₂/CH₄ separation of a facilitated transport membrane for natural gas sweetening. *J Membr Sci* 423–424(0):150–158
148. Uddin MW, Hägg M-B (2012b) Natural gas sweetening—the effect on CO₂-CH₄ separation after exposing a facilitated transport membrane to hydrogen sulfide and higher hydrocarbons. *J Membr Sci* 423–424(0):143–149
149. Vinoba M, Bhagiyalakshmi M, Alqaheem Y, Alomair AA, Pérez A, Rana MS (2017) Recent progress of fillers in mixed matrix membranes for CO₂ separation: a review. *Sep Purif Technol* 188:431–450
150. Wang C, Ryman C, Dahl J (2009) Potential CO₂ emission reduction for BF-BOF steelmaking based on optimised use of ferrous burden materials. *IJGGC* 3(1):29–38

151. Wang M, Zhao J, Wang X, Liu A, Gleason KK (2017) Recent progress on submicron gas-selective polymeric membranes. *J Mater Chem A* 5(19):8860–8886
152. Wind JD, Paul DR, Koros WJ (2004) Natural gas permeation in polyimide membranes. *J Membr Sci* 228(2):227–236
153. Wind JD, Staudt-Bickel C, Paul DR, Koros WJ (2002) The effects of crosslinking chemistry on CO₂ plasticization of polyimide gas separation membranes. *Ind Eng Chem Res* 41(24):6139–6148
154. Woo KT, Lee J, Dong G, Kim JS, Do YS, Hung W-S, Lee K-R, Barbieri G, Drioli E, Lee YM (2015) Fabrication of thermally rearranged (TR) polybenzoxazole hollow fiber membranes with superior CO₂/N₂ separation performance. *J Membr Sci* 490:129–138
155. Xu L, Rungta M, Brayden MK, Martinez MV, Stears BA, Barbay GA, Koros WJ (2012a) Olefins-selective asymmetric carbon molecular sieve hollow fiber membranes for hybrid membrane-distillation processes for olefin/paraffin separations. *J Membr Sci* 423–424:314–323
156. Xu L, Rungta M, Brayden MK, Martinez MV, Stears BA, Barbay GA, Koros WJ (2012b) Olefins-selective asymmetric carbon molecular sieve hollow fiber membranes for hybrid membrane-distillation processes for olefin/paraffin separations. *J Membr Sci* 423–424(0):314–323
157. Xu L, Rungta M, Koros WJ (2011) Matrimid® derived carbon molecular sieve hollow fiber membranes for ethylene/ethane separation. *J Membr Sci* 380(1–2):138–147
158. Yang H, Xu Z, Fan M, Gupta R, Slimane RB, Bland AE, Wright I (2008) Progress in carbon dioxide separation and capture: a review. *J Environ Sci* 20:14–27
159. Yeon S-H, Lee K-S, Sea B, Park Y-I, Lee K-H (2005) Application of pilot-scale membrane contactor hybrid system for removal of carbon dioxide from flue gas. *J Membr Sci* 257(1–2):156–160
160. Yong WF, Li FY, Xiao YC, Chung TS, Tong YW (2013) High performance PIM-1/Matrimid hollow fiber membranes for CO₂/CH₄, O₂/N₂ and CO₂/N₂ separation. *J Membr Sci* 443(0):156–169
161. Yoshimune M, Fujiwara I, Haraya K (2007) Carbon molecular sieve membranes derived from trimethylsilyl substituted poly(phenylene oxide) for gas separation. *Carbon* 45(3):553–560
162. Yu C-H, Huang C-H, Tan C-S (2012) A review of CO₂ capture by absorption and adsorption. *Aerosol Air Qual Res* 12(5):745–769
163. Zhang B, Wang T, Zhang S, Qiu J, Jian X (2006) Preparation and characterization of carbon membranes made from poly(phthalazinone ether sulfone ketone). *Carbon* 44(13):2764–2769
164. Zhang X, Zhang X, Dong H, Zhao Z, Zhang S, Huang Y (2012) Carbon capture with ionic liquids: overview and progress. *Energy Environ Sci* 5(5):6668–6681
165. Zhao S, Feron PHM, Deng L, Favre E, Chabanon E, Yan S, Hou J, Chen V, Qi H (2016) Status and progress of membrane contactors in post-combustion carbon capture: a state-of-the-art review of new developments. *J Membr Sci* 511:180–206
166. Zou J, Ho WSW (2006) CO₂-selective polymeric membranes containing amines in crosslinked poly(vinyl alcohol). *J Membr Sci* 286(1–2):310–321

Ready to submit your research? Choose BMC and benefit from:

- fast, convenient online submission
- thorough peer review by experienced researchers in your field
- rapid publication on acceptance
- support for research data, including large and complex data types
- gold Open Access which fosters wider collaboration and increased citations
- maximum visibility for your research: over 100M website views per year

At BMC, research is always in progress.

Learn more biomedcentral.com/submissions

