



**NTNU – Trondheim**  
Norwegian University of  
Science and Technology

# Electromagnetic Transient Modelling of Grounding Structures

**Irina Tikhomirova**

Master of Science in Electric Power Engineering

Submission date: June 2013

Supervisor: Hans Kristian Høidalen, ELKRAFT

Norwegian University of Science and Technology  
Department of Electric Power Engineering



## Problem Description

Grounding is an essential part of power systems often forgotten or ignored. Grounding plays an important role for power system safety and protection. Special computer programs like CDEGS are required to analyze grounding structures, but this is not directly compatible with other programs for analysis of over-voltages and transients. The main idea in this project is to create parameterized models of simple grounding systems for use in power system transient analysis. A large project at SINTEF called "Electromagnetic Transients in Future Power Systems" has requested the grounding modelling.

The master project consists of:

- Calculate tower grounding impedances as a function of frequency in CDEGS. Study rod, counterpoise, and ring electrodes.
- Vary electrode parameters like depth, radius, length and soil parameters, resistivity and permittivity, to cover all natural variations.
- Use Vector Fitting to convert frequency domain responses to time domain models.
- Study required sampling in the frequency domain and vector fitting order with various electrode and ground parameters.
- Investigate a method to interpolate the electrode and ground parameters. Create a look-up table for grounding structure modelling.
- Test the established time domain models with lightning impulse.



## Preface

This report contains the results of my master thesis work during the spring 2013 at Norwegian University of Science and Technology. The database and the function developed during the project are delivered as a ZIP-file.

If a reference is listed before sentence period it applies only to that sentence. In case when a reference is placed after a sentence period it applies to the whole preceding paragraph.

I would like to express sincere gratitude to my supervisor, Professor Hans Kristian Høidalen, for his invaluable help throughout the process. I wish to thank Dr. Bjørn Gustavsen at SINTEF Energy Research for providing me with valuable information about vector fitting and responding quickly to my questions. Thanks are also due to Arne Petter Brede at SINTEF Energy Research for his inputs on grounding methods during my master thesis work.

Trondheim, 11.06.2012

Irina Tikhomirova



## Abstract

Grounding is traditionally modelled as a pure resistance. This is a good approximation at low frequencies, but as the frequency gets higher, inductance starts to play an important role. To acquire accurate transient response of the system it is desirable to consider this fact. Special computer programs like CDEGS are required to analyze grounding structures, but this is not directly compatible with other programs for analysis of over-voltages and transients. The main objective of this project is to create a database containing frequency response for some common electrode types with different parameter combinations. This frequency response can be further used to create an equivalent time - domain grounding impedance that can be exported to EMTP programs.

Three types of ground electrodes were analyzed in this project; earthing rod, counterpoise grounding with four radials, and horizontal ring electrode. A uniform soil model with variable values of resistivity and relative permittivity was used in all simulations. Geometrical dimensions of the electrodes were varied as well. All conductors were modelled as bare copper conductors. Parameters were determined based on the results of simulations in CDEGS and general recommendations for grounding of transmission towers given by Statnett.

Unit current at different frequencies was injected into ground electrodes through a 0.1 meter long copper conductor. Ground potential rise of this conductor, which is equal to impedance to earth of the ground electrode, was extracted from HIFREQ in text format. Frequency resolution in the simulations is 10 points per decade between 0 and 0.1 MHz, 40 points between 0.1 and 1 MHz, and 80 points between 1 and 10 MHz. As a result of the project a database containing impedance and admittance as function of frequency for three types of electrodes has been created. Total number of responses stored in the database is 2268.

Vector Fitting is used to convert frequency domain responses to time domain state - space models or RLC - networks. Vector fitting is a method to approximate measured or calculated frequency domain responses with a sum of rational functions.

A Matlab routine `interfit.m` was developed to extract response of an electrode with given parameters. For parameters between the points in the database, linear interpolation is used. As a second step the function calls vector fitting that creates a time – domain model from the frequency response of the defined ground electrode. Order of approximation in vector fitting should be adjusted for each case, starting with a low value and gradually increasing it till a sufficient approximation after passivity enforcement is achieved.

Time – domain simulations in CDEGS and ATPDraw gave similar results when order of approximation in vector fitting was chosen correctly. Negligible deviation was observed between the responses in time range between 0 and 5  $\mu$ s in some cases. The results indicate that frequency - dependent models created by this method can be used in EMTP programs.





## Sammendrag

Jording er tradisjonelt modellert som en ren motstand. Dette er en god tilnærming ved lave frekvenser, men ved høye frekvenser øker virkningen av induktansen og det er ønskelig å ta dette i betraktning for bedre resultater i simulering av transiente forløp. Programmer som CDEGS brukes for å analysere jording, men modeller laget i slike program kan ikke brukes direkte i programmer for analyse av overspenninger og transienter, som for eksempel EMTP. Hovedmålet med masterprosjektet er å lage et bibliotek med frekvensavhengige modeller av noen vanlige jordelektroder, som videre kan brukes for å lage en ekvivalent modell for EMTP programmer.

Tre typer jordelektroder ble analysert i dette prosjektet; jordspyd, markestrålejording og ring jording. Homogent jordsmonn med varierende verdier av resistivitet og permittivitet ble brukt i simuleringer. Elektrodens størrelse ble også variert. Parametre ble definert basert på resultatene av simuleringene i CDEGS og generelle anbefalinger for jording av høyspent master gitt av Statnett.

Enhetsstrømm med forskjellige frekvenser ble i simuleringene i modulen HIFREQ påtrykt jordelektroder. Jordpotensialet, som er lik jordelektrodens impedans mot jord, ble hentet fra HIFREQ i tekstformat. Frekvensoppløsningen som ble brukt i simuleringene var 10 punkter per dekada mellom 0 og 0,1 MHz, 40 punkter mellom 0,1 og 1 MHz, og 80 punkter mellom 1 og 10 MHz. Som et resultat av prosjektet ble en database som inneholder admittans som funksjon av frekvensen for tre typer av elektroder laget. Antall responser lagret i databasen er 2268.

Vector Fitting brukes til å konvertere responsen fra frekvensplanet til tidsplanet representert med RLCG-modell. Vector Fitting er en metode for å tilnærme målt eller beregnet respons i frekvensplanet med en sum av rasjonale funksjoner.

En Matlab kode *interfit.m* ble utviklet for å finne responsen for en jordelektrode med bestemte parametre. For parametre mellom punktene i databasen brukes lineær interpolering. Funksjonen kaller videre opp Vector Fitting. Orden av tilnærming i Vector Fitting bør justeres for hvert enkelt tilfelle. En bør starte med en lav verdi og gradvis øke den til tilstrekkelig nøyaktighet oppnås.

Simuleringer i tidsplanet i CDEGS og ATPDraw ga overensstemmende resultater dersom orden av tilnærming i Vector Fitting var riktig tilpasset. Ubetydelig avvik ble registrert mellom 0 og 5  $\mu$ s i noen tilfeller. Resultatene indikerer at frekvensavhengige modeller laget med denne metoden kan anvendes i EMTP programmer.



# Table of Contents

- 1. Introduction..... 1
- 2. Grounding Theory ..... 2
  - 2.1. Definition and Basic Principles ..... 2
  - 2.2. Common Electrode Types ..... 4
    - 2.2.1. Earthing Rod ..... 4
    - 2.2.2. Radial Arrangement (Counterpoise Grounding) ..... 4
    - 2.2.3. Horizontal Ring Electrode ..... 5
  - 2.3. Impulse Grounding ..... 6
  - 2.4. Analytical Formulas ..... 10
- 3. CDEGS..... 13
  - 3.1. General Information ..... 13
  - 3.2. MALZ and HIFREQ Engineering Modules..... 14
- 4. Vector Fitting..... 15
- 5. Parameter Resolution..... 17
  - 5.1. Soil Resistivity ..... 17
    - 5.1.1. Earthing Rod ..... 17
    - 5.1.2. Counterpoise Grounding ..... 18
    - 5.1.3. Ring Electrode..... 19
    - 5.1.4. Recommended Values..... 20
  - 5.2. Cross-Sectional Area..... 21
    - 5.2.1. Earthing Rod ..... 21
    - 5.2.2. Counterpoise Grounding ..... 22
    - 5.2.3. Ring Electrode..... 24
  - 5.3. Geometrical Dimensions ..... 25
    - 5.3.1. Earthing Rod ..... 25
    - 5.3.2. Counterpoise Grounding ..... 27
    - 5.3.3. Ring Electrode..... 29
  - 5.4. Burial Depth..... 31
  - 5.5. Soil Permittivity ..... 33
    - 5.5.1. Case 1 ..... 33
    - 5.5.2. Case 2 ..... 36
    - 5.5.3. Case 3 ..... 38

5.5.4.	Recommended Values.....	41
5.6.	Frequency Resolution.....	42
5.7.	Interpolation.....	44
5.8.	Discussion.....	46
6.	Results.....	48
6.1.	Electrode Modelling in CDEGS.....	48
6.2.	Structure Array.....	51
6.3.	Function interfit.m.....	52
6.4.	Analysis of Response Accuracy.....	54
6.4.1.	Impulse Current Description.....	54
6.4.2.	Example 1: Counterpoise Grounding.....	55
6.4.3.	Example 2: Counterpoise Grounding.....	57
6.4.4.	Example 3: Counterpoise Grounding.....	59
6.4.5.	Example 4: Horizontal Ring Electrode.....	62
6.4.6.	Example 5: Horizontal Ring Electrode.....	63
6.4.7.	Example 6: Earthing Rod.....	69
6.5.	Comparison of Different Grounding Models.....	71
6.6.	Discussion.....	74
7.	Conclusion.....	75
8.	Future Work.....	76
	References.....	77
	Appendix A.....	79
	Appendix B.....	84
	Appendix C.....	100
	Appendix D.....	102
	Appendix E.....	111
	Appendix F.....	113

## 1. Introduction

Grounding is an essential part of power systems. There are many challenges related to the choice of grounding system that meets all requirements. The decision concerning design and dimensions of grounding systems is often based on previous experience and recommendations. The future power systems will be very complex due to integration of renewable energy sources such as wind power, smart grids, voltage upgrades, and increased use of long cables. Therefore extensive computer simulations will be required for planning and analyzing of power systems. Existing simulation tools have limited accuracy for representing some critical components such as transformers and cables. SINTEF Energy Research is responsible for the project "Electromagnetic Transients in Future Power Systems". The main goal of this project is to develop and demonstrate tools for the evaluation of land - based and offshore power systems in order to ensure increased reliability of the supply and minimize the risk for failures due to unexpected interactions. In practice, this goal will be achieved by development of computational models of grid components for assessing transient voltages and currents in power grids.

Grounding is traditionally modelled as pure resistance. This is a good approximation at low frequencies, but as the frequency gets higher, inductance starts to play an important role. To acquire accurate transient response of the system it is desirable to consider this fact. To investigate how a specific electrode design responds to high frequent current (lightning surge), a field solver program can be used, such as CDEGS. CDEGS is an abbreviation for Current Distribution, Electromagnetic fields, Grounding and Soil structure. It is a software package delivered by Safe Engineering Services and Technologies Ltd. The problem is that models created in such programs are not compatible with EMTP. SINTEF Energy Research wishes to have a library of different frequency dependent models that can be used in EMTP.

The main objective of this project is to create a database containing frequency response for some common electrode types with different parameter combinations. This frequency response can be further used to create an equivalent grounding model that can be exported to EMTP programs. Influence from different parameters, such as soil resistivity, relative permittivity, and geometrical dimensions, on grounding impedance to earth is studied as a first step of the project. Parameters to be used in the simulations in CDEGS will be determined based on the results of this study. A second step in the project is to determine how the data will be stored and extracted from the database. Comparison of the time domain responses to impulse current of original grounding model in CDEGS and its equivalent model in ATPDraw will be done as the last step in the project.

## 2. Grounding Theory

### 2.1. Definition and Basic Principles

In general, power equipment is connected to earth through a ground connection of sufficiently low impedance and with sufficient current-carrying capacity to prevent the buildup of voltages that may damage the equipment or result in hazards to persons. According to the European standard EN 50341-1:2001, the grounding design of a power line has to:

1. Ensure mechanical strength and corrosion resistance
2. Withstand, from a thermal point of view, the highest fault current
3. Prevent damage to properties and equipment
4. Ensure personal safety with regard to voltages that appear during ground faults
5. Achieve a certain reliability of the line

For systems above 1 kV AC the requirements on earthing depend on the systems characteristic such as:

- Type of neutral point design: insulated, resonant earthing or low resistant neutral
- Type of supports: supports with or without built-in disconnectors or transformer stations
- Material used for supports: steel, reinforced concrete or wood
- Support site: normal or particularly exposed sites in swimming areas, camping sites or play ground [1]

When an overhead line is constructed with two or more different voltage levels, all these requirements should be met for each voltage level [2]. A grounding system is generally composed of one or more horizontal, vertical, or inclined electrodes, buried or driven into the soil.

According to EN 50341, overhead line supports of non - conducting material need not be grounded, although poles of distribution lines are grounded if ground wires are installed to improve the lightning performance of the line. Supports of conducting material are in principal grounded by their footings, but additional measures may be required. Ground wires, if used, are connected directly at the support top. Grounding of metallic supports may be done by burying the structure into the earth, but supplementary grounding is required when the design does not provide satisfactory impedance. For wood poles, one or more ground rods are buried near the pole, and a down lead, running vertically from the top of the pole along its length, is connected to these rods. [2]

The tower grounding impedance depends on the area of the tower steel (or grounding conductor) in contact with the earth, and on the resistivity of the earth. The latter, is not constant, fluctuates over time, and is a function of soil type, moist content, temperature, current magnitude, and wave shape. A low tower-footing resistance is essential for good lightning performance of an overhead power line. [3]

A grounding system should protect both against touch voltages under fault conditions (50 Hz currents), and transient overvoltage caused by lightning strokes. Touch voltage is defined as a potential difference a person touching a conductive part, while standing at 1 m horizontal distance from it, will be subjected to [4]. According to [5], at 50 Hz it is important to achieve the resistance to earth which is necessary to meet the requirement of permissible touch voltage. Under fault conditions it is 50 Hz current that flows through the electrode. That is why it is not that important to have short distance between the electrode and the equipment. However, in the case of high frequent currents it is important to have the electrode as close to the grounded equipment as possible. Internal inductance in the conductor will prevent the current from flowing to the far end of the conductor at high frequencies. Common practice is to build the majority of grounding systems as impulse grounding. [5] Impulse impedance of a ground electrode is discussed in details in Chapter 2.3.

High voltages can be generated on ground parts of power line support when either a ground wire or a phase conductor is struck by lightning. If lightning strikes a tower or a ground wire, the discharge should be then safely led to the earth and dissipated there. The purpose of grounding for protection against lightning is to bypass the energy of the lightning discharge safely to the ground; that is, most of the energy of the lightning discharge should be dissipated into the ground without raising the voltage of the protected system [3]. In [6] there are listed several recommendations to grounding system which ensure satisfactory protection against impulses:

1. Maximum extent of the grounding system should not exceed 30 m from the tower. In case when the soil resistivity is high it can be increased to 50 m.
2. Maximum resistance to earth should not exceed 60 Ohm, but if possible lower than 30 Ohm.
3. It is beneficial to use radial arrangement when the current is divided between several conductors. Radials of the electrode should be as far apart from each other as possible.
4. Earthing rods should be used as their resistance to earth is less affected of frost and humidity in the soil. The gap between the rods should be minimum 1.5 times the length of the rod.

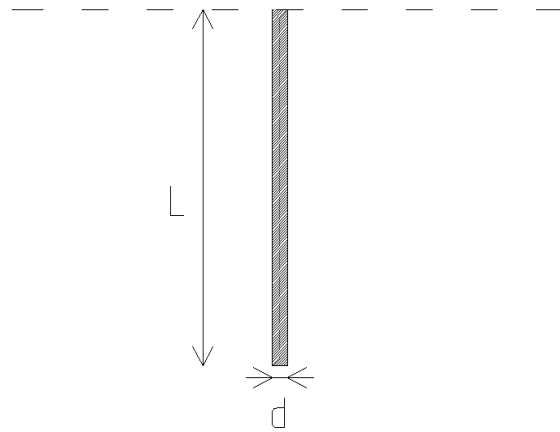
According to EN 50341 minimum cross-sectional area for copper wires should be  $25 \text{ mm}^2$ . However, [6] recommends use of copper wires with  $50 \text{ mm}^2$  cross - sectional area as a standard. Conductors with larger cross-sectional area withstand mechanical and thermal stresses better.

Minimum burial depth for horizontally placed wires varies from 0.4 to 0.7 meters depending on the type of soil. When planning the earthing it is important to keep in mind that shield wires can even out the earthing, meaning that poor grounding conditions at one tower can be compensated by better grounding at the other. This applies for the three closest towers in each direction. [7]

## 2.2. Common Electrode Types

### 2.2.1. Earthing Rod

It is a frequently used grounding method; one or more metallic rods are driven vertically down into the soil. This type of grounding is typically used in the soils with high resistivity to achieve sufficiently low earthing resistance. For example for moraine or clay the necessary depth to achieve low resistance to earth can be 10 -15 m or even more. If several rods are used, they are usually connected together with bare conductors, but use of insulated conductors is also possible to avoid corrosion due to galvanic potential difference to the rods. Figure 2.1 gives a schematic illustration of this type of grounding. [8]



**Figure 2.1 Earthing rod**

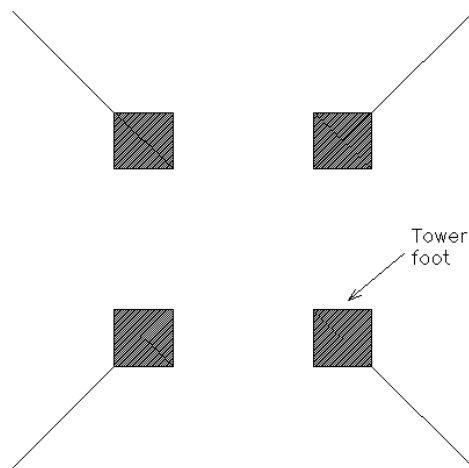
If several rods are used they can be placed in a ring or in a straight line. Both arrangements give approximately equal resistance to earth. Resistance to earth is reduced by increasing number of rods. [8]

### 2.2.2. Radial Arrangement (Counterpoise Grounding)

In some cases it can be an advantage to use horizontally placed ground electrodes. Resistance to earth of a horizontal electrode decreases when the depth at which the electrode is buried increases. Connecting several horizontal electrodes in parallel will also reduce the total resistance to earth. Counterpoise wires arranged radial or as rings and rigidly connected with the tower are commonly used for earthing of supports for overhead transmission lines. It is advantageous to use radial arrangement because it gives lower initial impedance for lightning or high-frequency currents than impedance of single or parallel electrodes. [8] Counterpoise grounding is the most commonly used method by Statnett. The ground wires are buried radial, with an angle of  $90^\circ$  between them to reduce the mutual inductance as illustrated in Figure 2.2. [7]



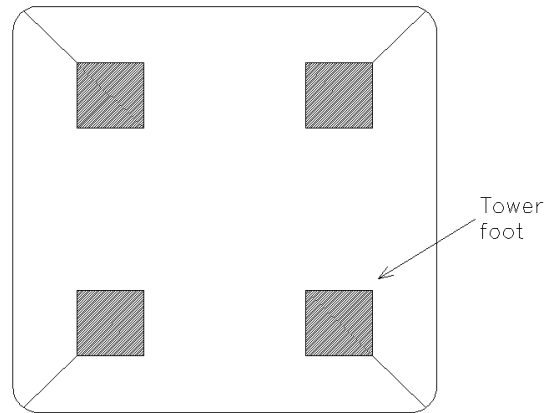
Counterpoises are installed at each tower foot in order to minimize their effect on each other. At least two radials should be used. In case of lightning strike, it is the first 30 meters of the radial length that are important. If there are better soil conditions farther away it can be beneficial to extend the radial, but the length should not exceed 60 m. In some cases, 80 m can be allowed. If conditions at the site allow it, the largest separation between the radials should be chosen (Figure 2.2). This geometry gives the lowest mutual electromagnetic influence for the conductors. The minimum length of the radial should be around 15 meter. This type of grounding should not be used in farmland and areas with a lot of traffic to avoid damage of the conductors by agricultural equipment. [9]



**Figure 2.2 Counterpoise grounding**

### 2.2.3. Horizontal Ring Electrode

A conductor can be put as a ring into the earth as illustrated by Figure 2.3. The ground conductor is buried in a ring around the feet of the tower and connected to each foot [7]. Ring earthing is typically used in farmland and in places where the distance to the road is less than 30 meters. The electrode is, in this case, better protected against damage from agricultural equipment because it is buried close to the tower. Ring earthing is attached to each foot and is usually buried at 0.7 m depth. This type of grounding (equipotential grounding) provides good protection against high step voltages, and gives lower touch voltages. Step voltage is defined as voltage between two points on Earth's surface that are 1 m distant from each other, which is considered to be a stride length of a person. [9]



**Figure 2.3 Horizontal ring electrode**

### 2.3. Impulse Grounding

When current is discharged into the soil through a ground electrode, potential gradients are set up as a result of the conduction of current through the soil. The ground impedance is given by the relationship between the potential rise of the electrode and the current discharged into the ground. The representation of the ground impedance depends on the frequency range of the discharged current. Grounding models can be classified into two groups: low- and high-frequency models. In practice, they correspond respectively to power-frequency and to lightning stroke discharged currents. [10]

At power-frequency the grounding impedance can be represented by the dissipation resistance, defined as a ratio between the voltage between the feed point at the grounding system and the point at remote neutral ground and the injected current. For high – frequency phenomena such as lightning, several aspects determine the magnitude and shape of the transient voltage that appear at the tower base. They include the surge impedance of buried wires, the surge impedance of the ground plane, and soil ionization. [10]

Lightning is associated with discharge of large currents to grounded objects. When the lightning strikes a point, the voltage developed is the lightning discharge current multiplied by the impedance of the system as seen by the lightning current. High-voltage power lines and tall towers are susceptible to direct lightning strokes. However, even if lightning strikes the level ground, the electric and magnetic fields of the lightning channel can induce high enough voltage on a nearby low-voltage power line to trigger the system outage. [3]

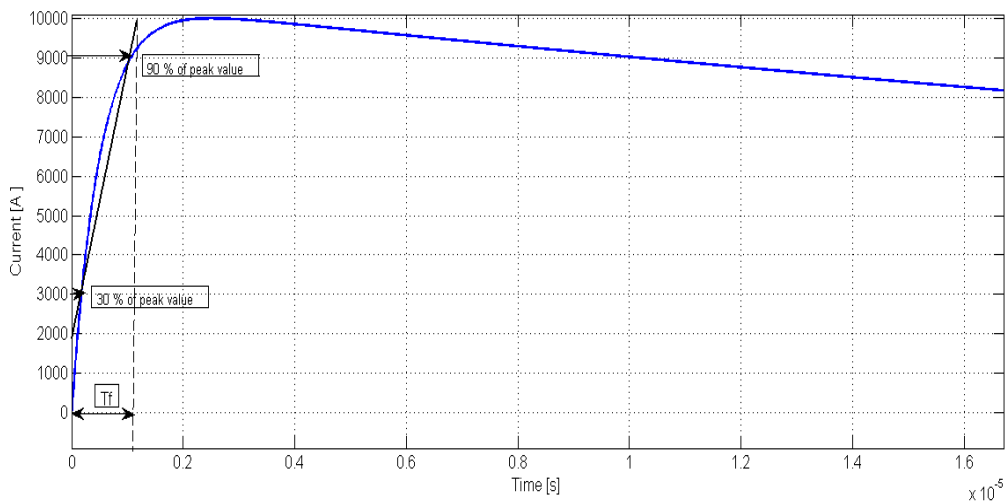
The surge impedance of a ground electrode is identified as the ratio of the peak value of the voltage developed at the feeding point to the peak value of the injected current. The effect of

the conductor radius on the surge impedance of a grounding system is not significant. The surge impedance is in general higher than the power - frequency resistance. [10]

A lightning current rises to its peak in a time which varies from less than a microsecond to 10 - 20 microseconds, and then decays within a few hundred microseconds. Protection of power systems against lightning has been a serious concern of power engineers almost since the beginning of the twentieth century. A lightning stroke is a random phenomenon. However, statistical data on the peak current, wave shape and the frequency of strike around the world has been accumulated over the years. These data are used to design protective schemes for electrical systems. [3]

If the possible lightning current is known, than impulse grounding resistance can be used to estimate the potential of the grounding electrode generated by lightning current. This is very important for lightning protection of transmission line. [11] There are several parameters that are used to describe the lightning current wave shape: front time, steepness of the curve, peak value and duration of the lightning strike. Front time is defined in Figure 2.4, it is the time it takes for a straight line drawn between 30 % and 90 % of peak value to rise from 0 to 100 %. Duration of a lightning strike is defined as a time it takes current to decrease to 50 % of its peak value. For laboratory experiments it is common to use lightning impulse with front time equal to  $1.2 \mu\text{s}$  and duration of the strike equal to  $50 \mu\text{s}$ . [12]

Current form shown in Figure 2.4 has front time of approximately  $1.2 \mu\text{s}$ . The front shape is very steep at the start so the line drawn between 30 % and 90 % of the peak value does not reach zero before time is zero.



**Figure 2.4 Lightning current**

Depending on the mechanism of formation of the discharge one differentiate between positive and negative lightning strikes. A thundercloud consists of a dipole of electrical charges – usually layers of positive charge at the top and layers of negative charge at the bottom. A layer of weak

positive charge is also found at the bottom of a thundercloud. [3] Negative lightning strikes occur when the discharge starts at the bottom of a thundercloud, which is negatively charged. In the case of the positive lightning strike, the discharge starts at the top of a thundercloud where positive charge is concentrated. The majority of the lightning strikes belong to the negative type. However, in the northern areas positive lightning strikes are more common. [12]

Grounding system performance is well understood at power frequency and detailed procedure for their design is developed. However, during a lightning strike the grounding system's performance can be quite different. Impulse performance of a ground electrode is dependent on current magnitude, its rise time, soil resistivity and electrode's geometry. Reducing impulse resistance of tower-foot grounding is an effective method to prevent accidents caused by lightning strikes in transmission systems. Detailed description of how different factors affect impulse performance of a ground electrode follows below.

- ***Current magnitude***

Impulse grounding resistance decreases when impulse current increases. This happens due to soil ionization around the ground electrode when high currents are discharged into the soil. Under lightning surge conditions and some power-frequency fault conditions, the high current density in the soil increases the electric field strength up to values that cause electrical discharges in the soil that surrounds the electrode. The plasma of the discharges has a resistance lower than that of the surrounding soil, so there is an apparent decrease of the ground resistivity in areas where ionization occurs. Since ionization occurs mainly near the electrode where the current density is highest, it increases the effective size of the electrode and results in a reduction in the electrode resistance. Intensity of the ionization is especially high when the soil is dry and when it has high resistivity. [10]

Soil ionization is believed to be an important factor in the study of the impulse characteristics of grounding devices. Experiments performed on the electrodes with reduced scale by He et al. [13] showed that the impulse grounding resistance decreases with increasing impulse current, and has a saturation trend. After a certain value, even if the impulse current increases drastically, the impulse grounding resistance decreases slowly. The saturation current level is lower in highly conductive soil compared to the soil with high resistivity. [13]

The magnitude of electric field which initiates ionization process is known as critical electric field. This parameter can be used to determine the degree of resistance reduction in the soil. In addition, consideration of critical electric field can help to optimize the design of grounding systems. There have been many studies on determining the value of critical electric field in the soil, and different values ranging between 1.3 and 20 kV/cm have been suggested. Results from these studies suggest that critical electric field in the soil is affected by several factors such as soil types, soil grain

size, impulse rise time and impulse polarity. [14] Experiments in [14] showed that impulse polarity can affect the withstand level for electric field in the soil; the threshold electric field was higher for negative impulse polarity than for positive impulse polarity for wet sand. [14]

- ***Current rise time***

The lightning current waveform has a major influence on the dynamic performance of ground electrodes. Experiments performed on a real size horizontal electrode by Haddad et al. showed that for the impulse with the short rise time, the reduction in current magnitude is larger than that observed with the longer rise time. This fact indicates that for the same current magnitude, the fast rising current dissipates to ground more quickly than the slow rising current. [15] The faster fronted current pulse results in larger potential at feed point in the first moments because larger currents are forced to disperse into the ground through small parts of the electrode [16].

- ***Soil resistivity***

Experiments performed in [17] showed the relationship between impulse grounding resistance and soil resistivity to be non-linear. Impulse grounding resistance increases with increasing soil resistivity. The impulse grounding resistance increases linearly with the soil resistivity when it is low. However, the increase becomes slow when the soil resistivity is high. The curves obtained by He et al. showed that when the soil resistivity exceeds 3000 Ohmm impulse grounding resistance rises very slowly, and has a saturation trend with the increase of soil resistivity. [17]

- ***Geometry of the electrode***

Impulse grounding resistance reduces with increasing geometrical dimensions. Increase in geometrical dimensions allows the electrode to spread current better into the soil, so the resistance will decrease. However, at high frequencies the inductance of the grounding system will hinder current from flowing to the far part of the grounding system so it would not be used completely. The inductive effect of the grounding conductor due to the high frequency of impulse current would block the current from flowing towards the other end of the conductor. This will result in extremely unequal leakage current distribution along the grounding conductor. Potential distribution along the grounding conductor, ionization degree, and equivalent radius of the ionized soil around every point of the conductor will be also non – uniform under high frequent impulse current. [11] Therefore, the impulse grounding resistance as a function of geometrical extension of the ground electrode has a saturation trend, and the grounding device has an effective geometrical dimension [17].

An impulse coefficient is a ratio of the impulse grounding resistance and the power frequency one. The impulse impedance decreases with increase of electrode length, but at a certain length, it becomes constant, while the low - frequency resistance continues

to decrease resulting in impulse coefficient larger than one. Therefore, only a certain electrode length is effective in controlling the impulse impedance, which is referred as effective length. Therefore, the effective length can be defined as a maximum electrode length for which the impulse coefficient is equal to one. The effective length is larger for more resistive earth and slow fronted current pulses. [16]

The power frequency resistance of a ground electrode can be easily measured. However, it is difficult or sometimes even impossible to measure impulse impedance of a grounding device. In order to analyze the lightning protection characteristics of a transmission line, one measures power frequency grounding resistance, and obtain the impulse grounding impedance by multiplying the power frequency resistance with the impulse coefficient. Impulse coefficient is determined by the structure of the grounding device, soil resistivity, and the lightning current peak value. [13]

Experimental results in [13] showed that the effective dimension increases with the soil resistivity because soil conductivity becomes bad when the soil resistivity increases. The current flowing into the earth in the portion of the electrode near the current input point will decrease relatively, and more current will flow into ground from the far portion of the electrode. The effective dimension increases with the impulse current, because the increase of current density on the surface of the electrode leads to more current flowing into the remote part of the grounding conductor. [13]

- **Burial depth**

Impulse grounding resistance decreases with the increase of burial depth, and there is an effective burial depth for horizontal electrodes [17].

Experiments [17] with electrodes made of steel and copper showed that the difference in impulse impedance for electrodes of the same shape and size was negligible.

## 2.4. Analytical Formulas

At low frequencies impedance of a ground electrode can be approximated as a pure resistance. For simple electrode types resistance to earth can be calculated using analytical formulas listed below.

### Earthing rod

$$R_e = \frac{\rho}{2\pi l} \left[ \ln \frac{8l}{d} - 1 \right] \quad (6)$$

Where

$\rho$  - soil resistivity [ $\Omega\text{m}$ ]

$d$  - conductor diameter [m]

$l$  - conductor length [m]

### Counterpoise grounding with n radials

$$R_{en} = \frac{\rho}{n\pi l} \left[ \ln \frac{4l}{d} + N(n) \right] \quad (7)$$

Where

$\rho$  - soil resistivity [ $\Omega\text{m}$ ]

$d$  - conductor diameter [m]

$l$  - length of a single conductor [m]

$n$  - number of conductors

$N(n)$  – constant given in Table 4.4

$$d_{ekv} = \sqrt{dh} \quad (8)$$

Where

$d$  - conductor diameter [m]

$h$  - depth at which conductors are buried [m]

### Ring electrode

$$R_e = \frac{\rho}{2\pi^2 R} \ln \frac{16R}{\sqrt{dh}} \quad (9)$$

Where

$R$  - radius of the ring [m]

$\rho$  - soil resistivity [ $\Omega\text{m}$ ]

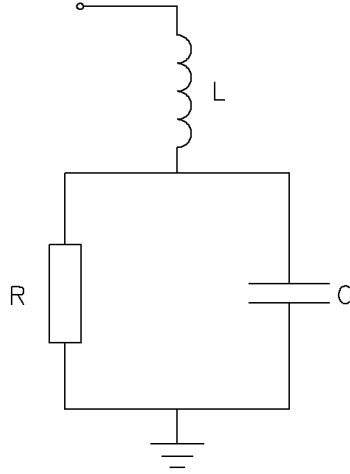
$d$  - conductor diameter [m]

$h$  - depth at which conductors are buried [m]

These formulas are frequency independent and do not take into account soil permittivity.

### Lumped-parameter grounding model

A high-frequency model of a ground electrode is suggested in [10]. This circuit is illustrated in Figure 2.5.



**Figure 2.5 Lumped -parameter equivalent circuit of a ground electrode**

For an earthing rod components of this circuit can be calculated using following formulas [10]:

$$R_e = \frac{\rho}{2\pi l} \left[ \ln \frac{4l}{a} - 1 \right] \quad (10)$$

$$L = \frac{\mu_0}{2\pi} l \left[ \ln \frac{4l}{a} - 1 \right] \quad (11)$$

$$C = 2\pi\epsilon l \left[ \ln \frac{4l}{a} - 1 \right] \quad (12)$$

Where

$\rho$  - soil resistivity [ $\Omega\text{m}$ ]

$a$  - conductor radius [m]

$l$  - conductor length [m]

$\epsilon = \epsilon_r \epsilon_0$  - permittivity of the soil

$\epsilon_r$  - relative permittivity of the medium

$\epsilon_0$  - vacuum permittivity, equal to  $8.854187\text{e-}12$  [F/m]



### 3. CDEGS

#### 3.1. General Information

CDEGS Software package was developed by Safe Engineering Services and technologies Ltd. CDEGS is an abbreviation for Current Distribution, Electromagnetic fields, Grounding and Soil structure analysis. CDEGS software package is a powerful set of integrated engineering software tools designed to analyze problems involving grounding, electromagnetic fields, and electromagnetic interference studies. CDEGS computes conductor currents and electromagnetic fields generated by an arbitrary network of energized conductors anywhere above or below ground for normal, fault, lightning and transient conditions. CDEGS capabilities are:

- Soil resistivity analysis
- Grounding analysis: arbitrary soil structures; any frequency and transients.
- Line constants for overhead and buried conductors or complex pipe-enclosed cable arrangements
- Load, fault and transient current distribution.
- Cathodic protection analysis of complex buried networks.
- Inductive, conductive and capacitive interference in shared corridors.
- Frequency and time domain analysis of electromagnetic fields generated by arbitrary energized conductor networks [18]

CDEGS is composed of eight engineering modules RESAP, MALT, MALZ, TRALIN, SPLITS, HIFREQ, FCDIST, and FFTSES. CDEGS also includes input and output processors and utilities. A short description of the module functions is given hereafter.

- RESAP: Soil Resistivity Analysis
- MALT: Low Frequency Grounding/ Earthing Analysis
- MALZ: Frequency Domain Grounding/ Earthing Analysis
- TRALIN: Line and Cable Constants (Parameters) and Induction Analysis
- SPLITS: Detailed Fault Current Distribution and EMI Analysis
- HIFREQ: Electromagnetic Fields Analysis
- FFTSES: Automated Fast Fourier Transform Analysis
- FCDIST: Simplified Fault Current Distribution Analysis [18]

CDEGS software package contains also several powerful tools, one of which is SESCAD. SESCAD is a program that allows viewing or editing three-dimensional networks consisting of straight conductor segments. It is specially adapted for users of MALT, MALZ, and HIFREQ programs. This CAD program uses an object-oriented approach to network development. Elementary objects (conductors and observation profiles) can be created by simply drawing them or by entering data in dialog boxes. Composite objects can be formed by grouping existing objects together. [19]

### 3.2. MALZ and HIFREQ Engineering Modules

There are two modules in CDEGS suited for analyzing grounding networks at high frequencies; MALZ and HIFREQ. Information presented in this chapter is based on help-files available in CDEGS, and correspondence with support team at Safe Engineering Services and Technologies.

MALZ analyzes the frequency domain performance of networks of buried, current – carrying conductors and computes the following quantities:

- Magnetic field in the air,
- Conductor and earth potentials,
- Current distribution in the conductors.

This module is particularly suited to analyzing extensive ground networks which cannot be considered to be equipotential surfaces or which interact with nearby coated pipelines. MALZ is also an excellent tool for analyzing conductor networks energized by currents at frequencies varying from 0 Hz to about 1 MHz. Beyond this frequency band, MALZ is not a suitable computational program since it does not account for mutual inductance of the conductors.

The engineering module HIFREQ computes the current distribution in networks of buried and overhead conductors and the electric, magnetic and scalar potential fields generated by this current distribution. The computation frequency can vary from 0 Hz to several tens of MHz. Computational program HIFREQ eliminates all of the assumptions that are limiting frequency range in MALZ. Computation time for the same model is much longer in HIFREQ compared to MALZ. Since simulations in this project should be done for the frequency range between 0 Hz and 10 MHz HIFREQ is chosen for computations.

Three electrodes (earthing rod, counterpoise grounding with four radials and ring earthing) were analyzed both in MALZ and HIFREQ. Three cases were simulated first in highly conductive soil ( $\rho = 100 \text{ Ohmm}$ ), then in soil with high resistivity ( $\rho = 2000 \text{ Ohmm}$ ) at six frequencies (50 Hz, 1 kHz, 10 kHz, 100 kHz, 1 MHz and 10 MHz). Comparison of the results showed that values from MALZ are approximately equal to HIFREQ values at frequencies up to 100 kHz. After the frequency has passed 100 kHz small differences start to occur. Impedance values from MALZ are higher than the values from HIFREQ. At 10 MHz MALZ calculates the impedance that is twice as large as the one calculated in HIFREQ. This fact confirms that MALZ cannot be used in this project, since the simulations include frequencies above 1 MHz.

In addition to the frequency constraint, MALZ does not account for the permittivity of the soil because the permittivity generally has a negligible impact on the results obtained in the frequency band in which MALZ is valid. The theory underlying the computations in HIFREQ allows for the soil (and air) layers to have arbitrary conductivity, permittivity and permeability. Comparison of two cases with the same model simulated with the soil with relative permittivity equal to 1 and 10 respectively indicates that for the frequencies above 1 MHz relative permittivity of the soil plays an important role and cannot be disregarded.

#### 4. Vector Fitting

Vector fitting is a method for approximation of measured or calculated frequency domain responses as a rational function. This is achieved by replacing a set of starting poles with an improved set of poles via a scaling procedure. This method is demonstrated to be very suitable for fitting network equivalents and transformer responses. [20, 21] A Matlab routine vectfit3.m, which is an implementation of fast relaxed vector fitting (FRVF), computes a rational approximation from tabulated data in the frequency domain. Vectfit3.m approximates a frequency response  $Y(s)$  with a rational function, expressed in the form of a sum of partial fractions (Eq.1). [22]

$$Y(s) \approx \sum_{m=1}^N \frac{c_m}{s-a_m} + d + se \quad (13)$$

Where

$a_m$ - poles of the function

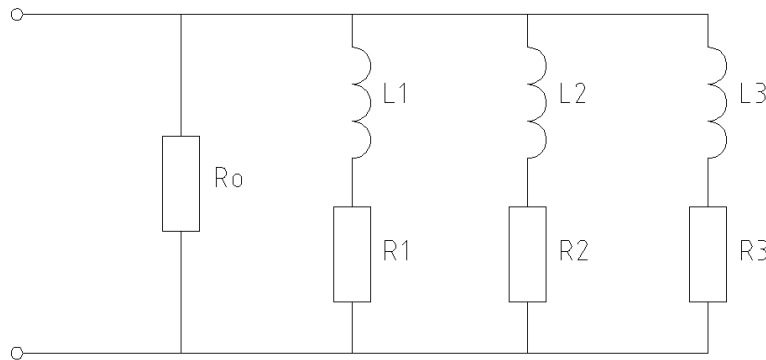
$c_m$ -residues

$d, e$ - optional elements

The model, as returned by vectfit3.m, is for convenience expressed as parameters of a state space model:

$$Y(s) \approx C(sI - A)^{-1}b + d + se \quad (14)$$

Using this method it is possible to approximate the frequency response of the ground electrode obtained from simulation as a set of impedances connected in parallel as shown in Figure 4.1.



**Figure 4.1 Approximation of grounding impedance based on its frequency response (real poles)**

The function obtained from vector fitting is equal to the admittance of the system. Admittance of the system is expressed as:

$$Y(s) = \frac{1}{R_0} + \frac{1}{R_1+sL_1} + \frac{1}{R_2+sL_2} + \dots + \frac{1}{R_m+sL_m} \quad (15)$$

Dividing each fraction by  $L_m$  gives:

$$Y(s) = \frac{1}{R_0} + \frac{\frac{1}{L_1}}{\frac{R_1}{L_1} + s} + \frac{\frac{1}{L_2}}{\frac{R_2}{L_2} + s} + \dots + \frac{\frac{1}{L_m}}{\frac{R_m}{L_m} + s} \quad (16)$$

The result is:

$$R_0 = \frac{1}{d} \quad (17)$$

$$L_m = \frac{1}{c_m} \quad (18)$$

$$R_m = \frac{-a_m}{c_m} \quad (19)$$

If complex poles are present, the model will consist of resistance, inductance, capacitance, and conductance (an RLCG –model).

This set of impedances can be used in EMTP programs to model the grounding system. This model is passive, meaning that it cannot generate power. Vector fitting, however, cannot enforce this condition on the system. Failure to comply with the passivity requirement can easily lead to an unstable simulation. Passivity can be enforced by perturbation of the eigenvalues of the residue matrices. [23, 24, 25, 26] This is implemented in Matrix Fitting Toolbox [27].

The output is a rational model on pole - residue form (Eq.1) and a corresponding state space model (Eq. 3), both with stable poles. There are several Matlab routines in Matrix Fitting Toolbox:

`VFdriver.m` – identifies models using the pole relocating Vector Fitting technique

`RPdriver.m` – perturbs the model so it becomes passive

`Netgen_ATP.m` – exports the obtained rational model into ATP simulation environment

When performing vector fitting one should remember that only positive frequency samples should be specified and the fitting order should be lower than the number of frequency samples. [28]

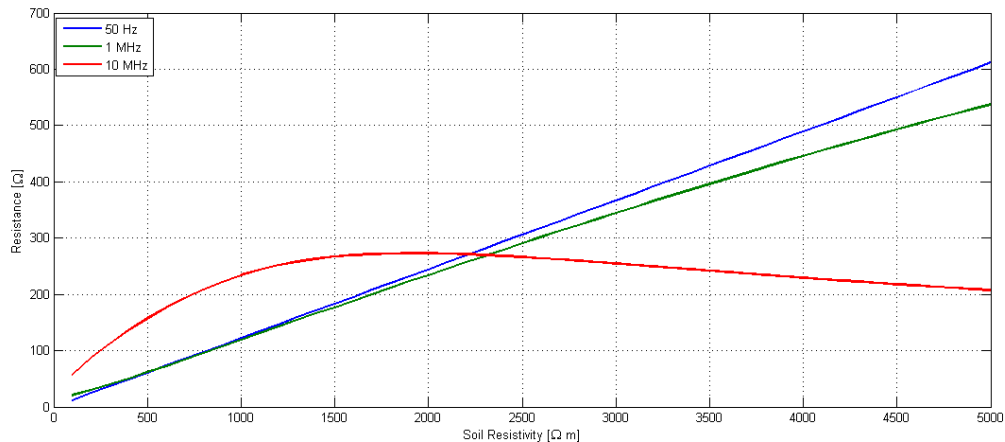
## 5. Parameter Resolution

This chapter presents results of the studies of impact on impedance to earth of a ground electrode from different parameters. The results have been used to determine parameters for CDEGS-simulations. Horizontal electrodes are buried 0.5 m deep into the soil for all cases described in this chapter.

### 5.1. Soil Resistivity

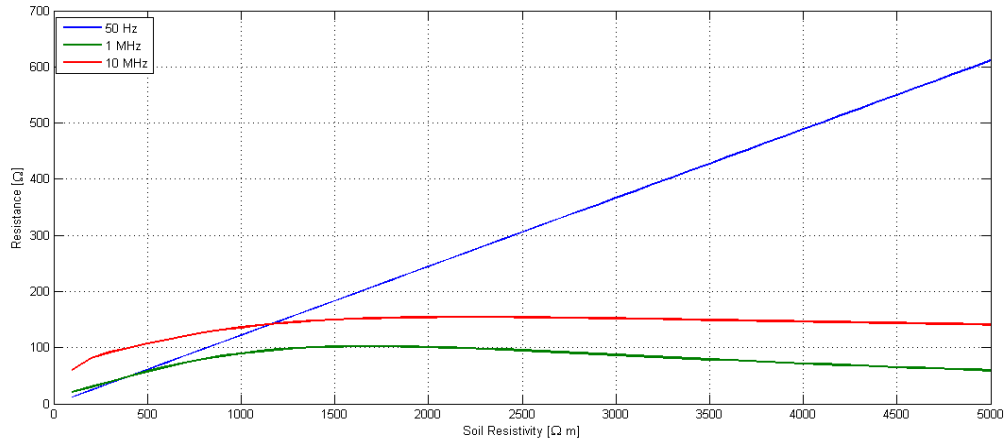
#### 5.1.1. Earthing Rod

The earthing rod used in simulations described in this chapter is 10 m long and has cross-sectional area equal to  $120 \text{ mm}^2$ . It is obvious from Figure 5.1 that resistance of a ground rod increases linearly with the soil resistivity at the frequencies up to 1 MHz. For the frequency equal to 10 MHz the relationship between resistance to earth of the ground electrode and soil resistivity is apparently non-linear. The curve shows that at high frequencies there are only slight changes in the resistance as the resistivity of the soil increases.



**Figure 5.1** Resistance of an earthing rod as a function of soil resistivity (length = 10 m,  $\epsilon_r = 1$ )

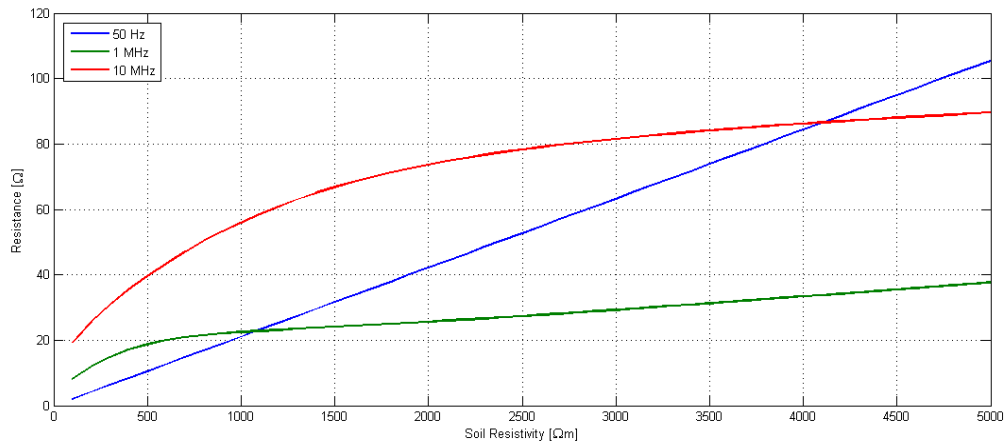
Changing relative permittivity from 1 to 10, leads to non - linear relationship between resistance to earth of a ground electrode and soil resistivity already at 1 MHz. As can be seen from Figure 5.2, at high frequencies there are only slight changes in the resistance when the soil resistivity exceeds 1000 Ohmm.



**Figure 5.2 Resistance of an earthing rod as a function of soil resistivity (length = 10 m,  $\epsilon_r = 10$ )**

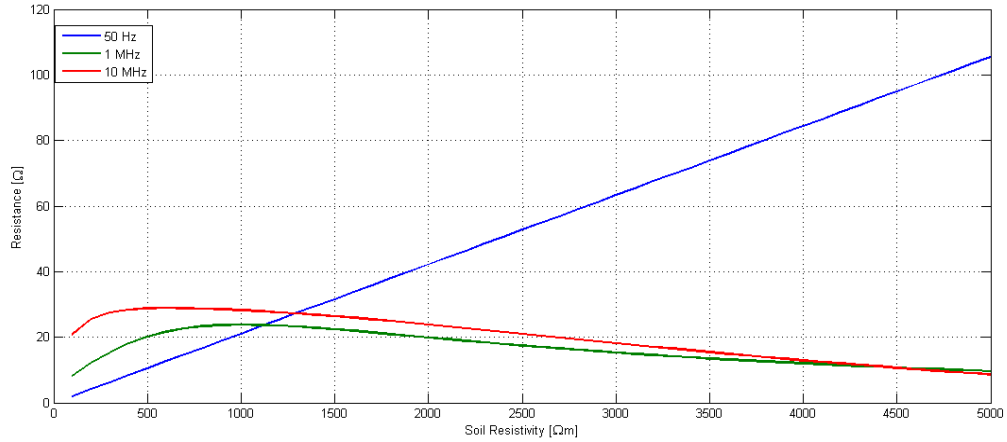
### 5.1.2. Counterpoise Grounding

A counterpoise grounding consisting of four radials each 30 metres long with cross – sectional area equal to  $50 \text{ mm}^2$  demonstrates non-linear behaviour both at 1 MHz and 10 MHz as illustrated in Figure 5.3. Resistance as a function of soil resistivity changes more rapidly at 10 MHz than at 1 MHz. In both cases, the curves have saturation properties with increasing resistivity.



**Figure 5.3 Resistance of a counterpoise electrode as a function of soil resistivity (radial length = 30 m, burial depth =0.5 m,  $\epsilon_r = 1$ )**

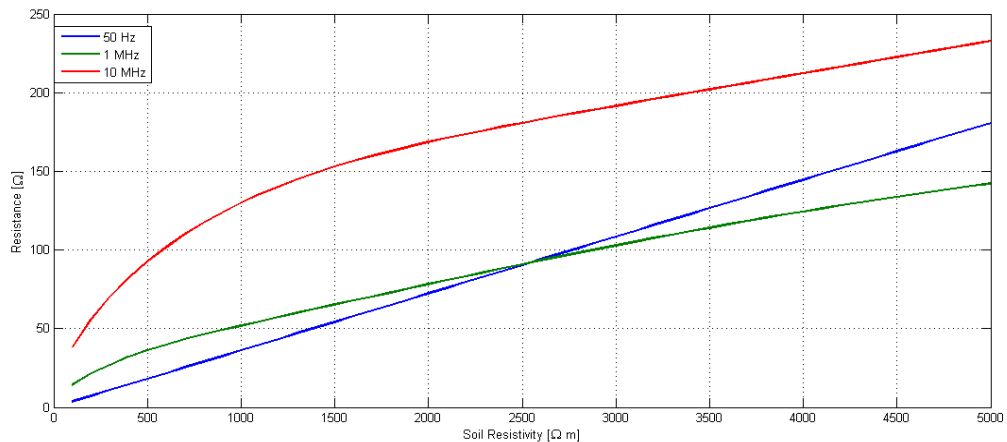
For relative permittivity of 10 (Figure 5.4), the curves for 1 and 10 MHz are very similar, with only slight difference between 100 to 4000 Ohmm. For values higher than 4000 Ohmm the curves almost overlap, and changes in the resistance are very small.



**Figure 5.4 Resistance of a counterpoise electrode as a function of soil resistivity (radial length = 30 m, burial depth = 0.5 m,  $\epsilon_r = 10$ )**

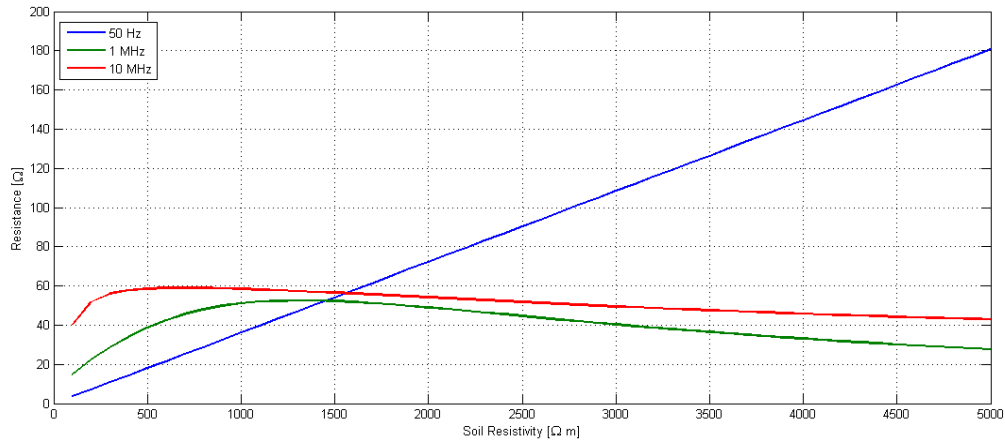
### 5.1.3. Ring Electrode

The results shown in Figure 5.5. and 5.6 are obtained for a ring with the radius equal to 10 m and cross-sectional area of  $50 \text{ mm}^2$ . The electrode is buried 0.5 meter deep into the ground. The response is slightly non-linear at 1 MHz while at 10 MHz non-linearity of the response becomes evident. 10 MHz resistance is higher than power-frequency resistance for all resistivity values.



**Figure 5.5 Resistance of a ring electrode as a function of soil resistivity (radius = 10 m, burial depth = 0.5 m,  $\epsilon_r = 1$ )**

When the relative permittivity is changed to 10, high - frequency resistance becomes lower than 50 Hz resistance for the values of soil resistivity higher than 1500 Ohmm. Similar to rod and counterpoise grounding there only small changes in the resistance due to changes in the soil resistivity at high frequencies which is illustrated by green and red curves in the Figure 5.6.



**Figure 5.6 Resistance of a ring electrode as a function of soil resistivity (radius = 10 m, burial depth = 0.5 m,  $\epsilon_r = 10$ )**

#### 5.1.4. Recommended Values

Based on the graphs presented above it is possible to conclude that resolution for the soil resistivity should be higher between 100 Ohmm and 2000 Ohmm. Above this value, larger steps can be chosen. Values suggested for analysis are listed in the Table 5.1. The highest values are chosen based on the typical values for different soil types listed in European Standard EN 50341-1 [2].

**Table 5.1 Values of soil resistivity for simulations in CDEGS**

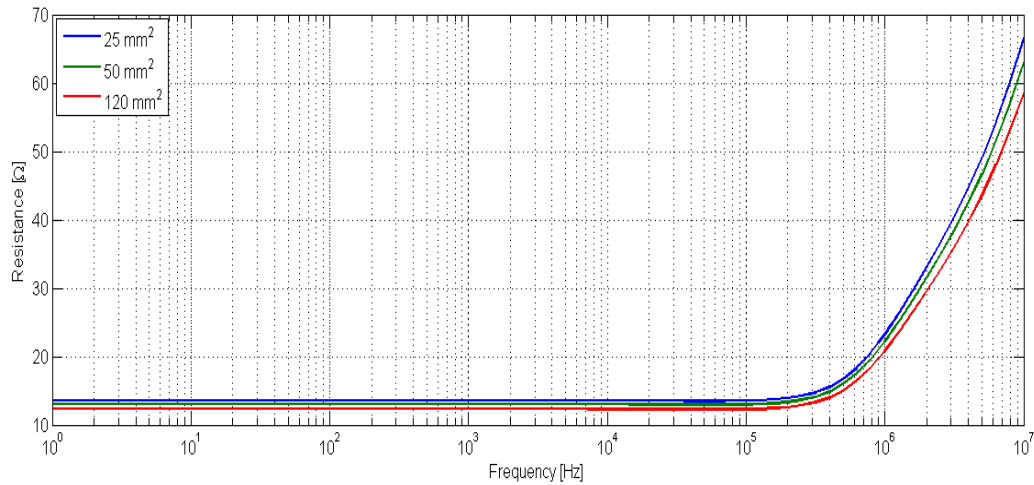
Soil resistivity [Ohmm]	100, 300, 500, 1000, 1500, 2000, 3000, 4000, 5000, 10000, 15000, 20000, 30000, 50000
-------------------------	--



## 5.2. Cross-Sectional Area

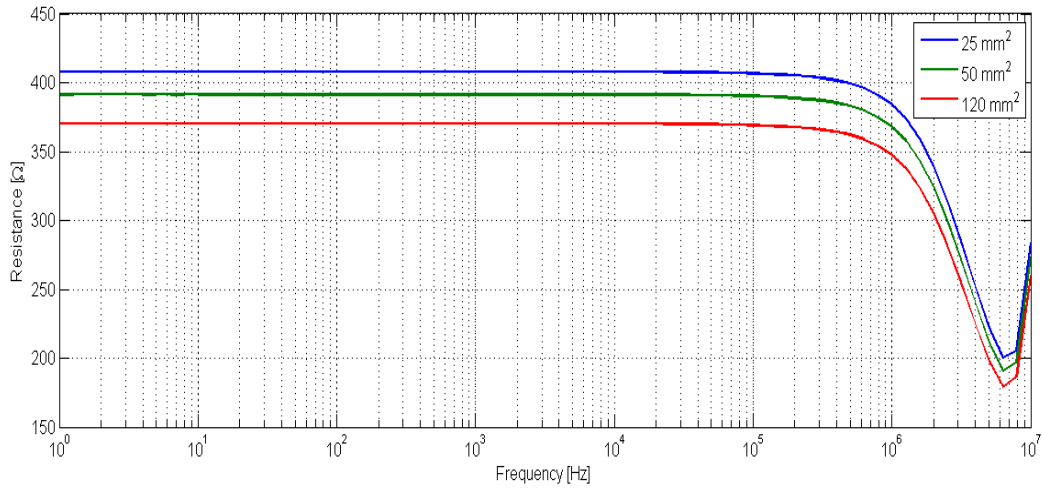
### 5.2.1. Earthing Rod

Figure 5.7 and 5.8 show resistances to earth as a function of frequency for earthing rods with three different cross-sectional areas in soil with resistivity equal to 100 Ohmm and 3000 Ohmm respectively. The length of the earthing rod is equal to 10 m. The graphs show that the difference between resistance values is quite small.



**Figure 5.7 Frequency response of an earthing rod with different cross-sectional area (length = 10 m, soil resistivity = 100 Ohmm,  $\epsilon_r = 1$ )**

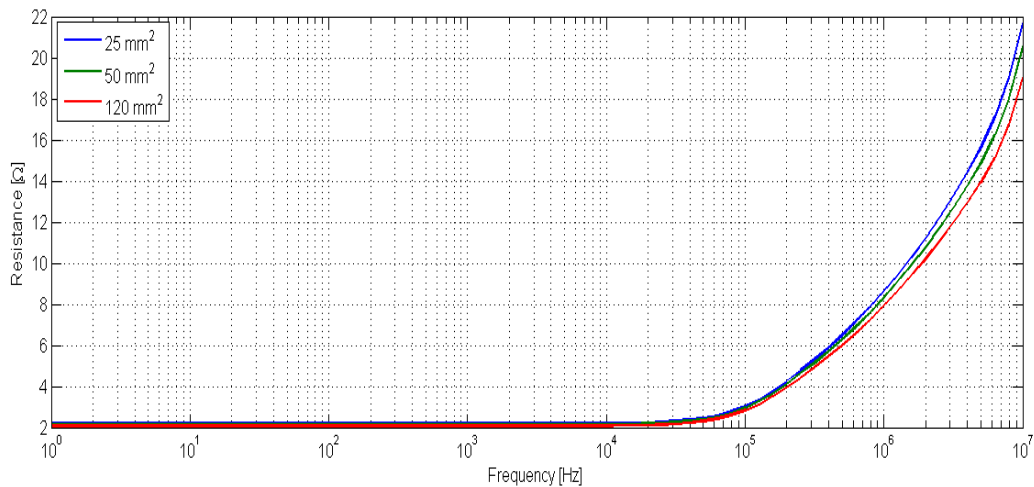
In the soil with high resistivity, the gap between the curves is larger but still the difference is below 5%. It is worth noticing that the curves in Figure 5.8 correspond to the curves obtained for resistance to earth as a function of soil resistivity (Figure 5.1). Resistance at 1 MHz is lower than power-frequency resistance, but higher than the resistance at 10 MHz.



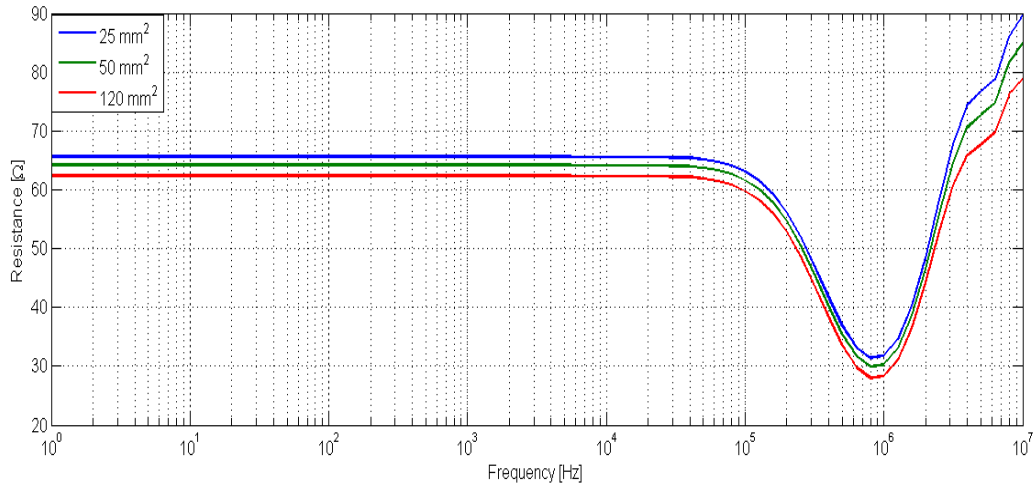
**Figure 5.8 Frequency response of an earthing rod with different cross-sectional area (length = 10 m, soil resistivity = 3000 Ohmm,  $\epsilon_r = 1$ )**

### 5.2.2. Counterpoise Grounding

Figure 5.9 and 5.10 illustrate the same simulations performed for counterpoise grounding with four radials. Length of each radial is equal to 30 meters and burial depth is 0.5 meters. The results indicate that when the extension of the grounding electrode is large resistance to earth of a grounding system is slightly dependent on the conductor cross-sectional area.



**Figure 5.9 Frequency response of a counterpoise grounding with different cross-sectional area (radial length =30 m, burial depth =0.5, soil resistivity = 100 Ohmm,  $\epsilon_r = 1$ )**

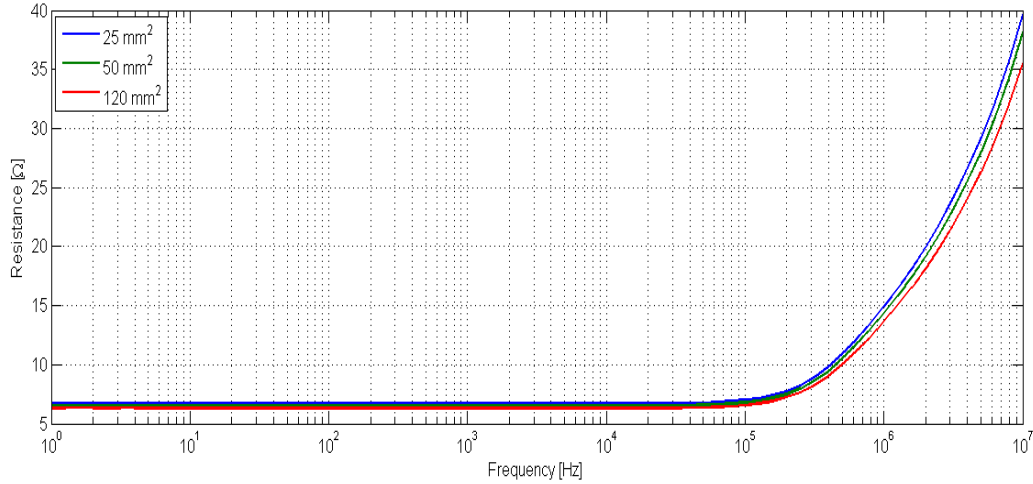


**Figure 5.10 Frequency response of a counterpoise grounding with different cross-sectional area (radial length =30 m, burial depth =0.5, soil resistivity = 3000 Ohmm,  $\epsilon_r =1$ )**

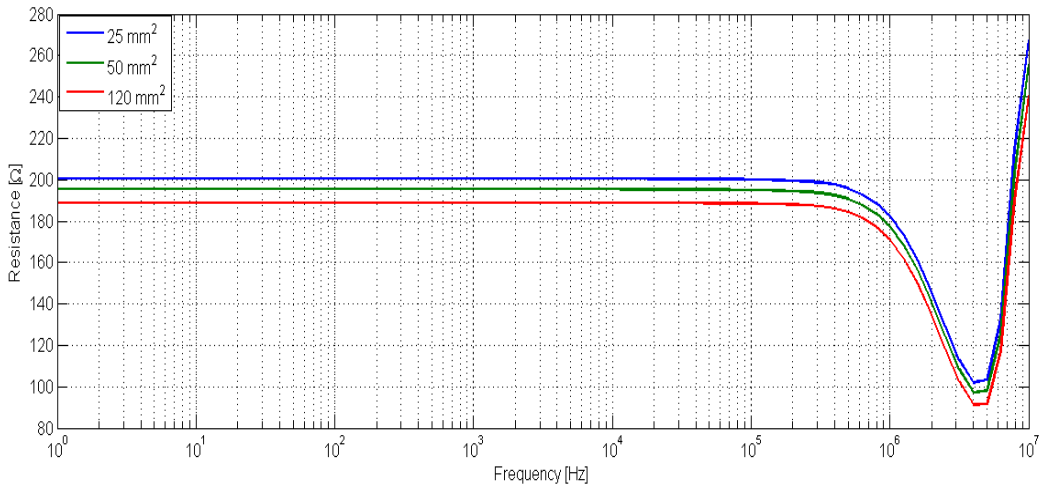
If Figure 5.10 is compared to Figure 5.3, it can be seen that for the soil resistivity equal to 3000 Ohmm 1 MHz resistance should be lower than both power- frequency and 10 MHz resistance which is true for Figure 5.10. 10 MHz resistance is higher than power frequency resistance and this fact also corresponds to the curves in Figure 5.3.

### 5.2.3. Ring Electrode

Same simulations were performed for a ring electrode. Responses presented in Figure 5.11 and 5.12 are similar to the responses of the configurations described above.



**Figure 5.11** Frequency response of a ring electrode with different cross-sectional area (radius =5 m, burial depth =0.5, soil resistivity = 100 Ohmm,  $\epsilon_r = 1$ )



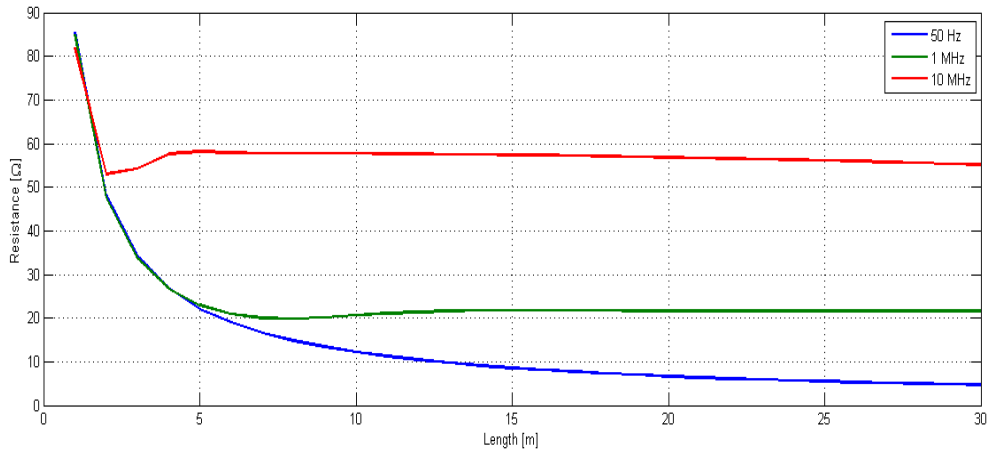
**Figure 5.12** Frequency response of a ring electrode with different cross-sectional area (radius =5 m, burial depth =0.5, soil resistivity = 3000 Ohmm,  $\epsilon_r = 1$ )

Based on these facts it is suggested that cross-sectional area can be set to a fixed value in the database. 50  $mm^2$  were chosen for ring and counterpoise grounding and 120  $mm^2$  for earthing rod.

## 5.3. Geometrical Dimensions

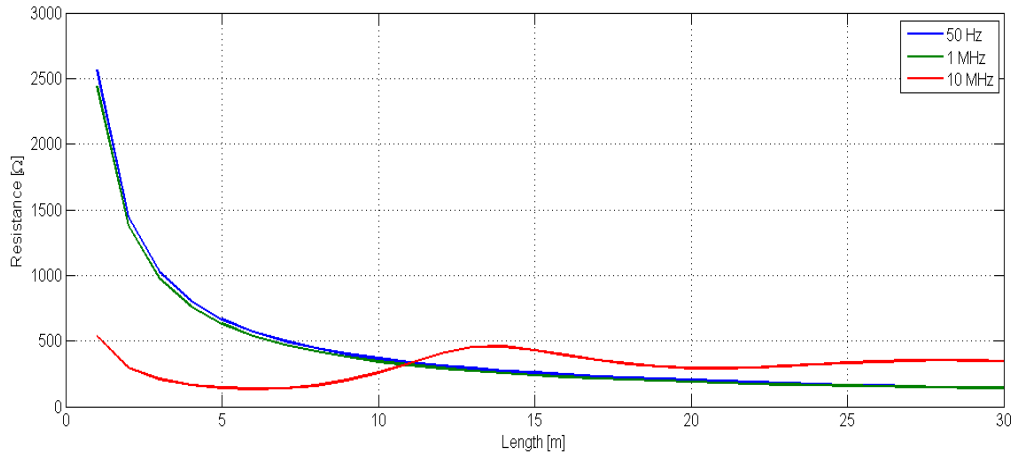
### 5.3.1. Earthing Rod

Figure 5.13 illustrates resistance's dependence on the length of the earthing rod at 50 Hz, 1 MHz and 10 MHz in the soil with resistivity of 100 Ohmm. These results indicate that earthing rods with extension exceeding 20 m are not an effective way of reducing resistance to earth of a grounding system.

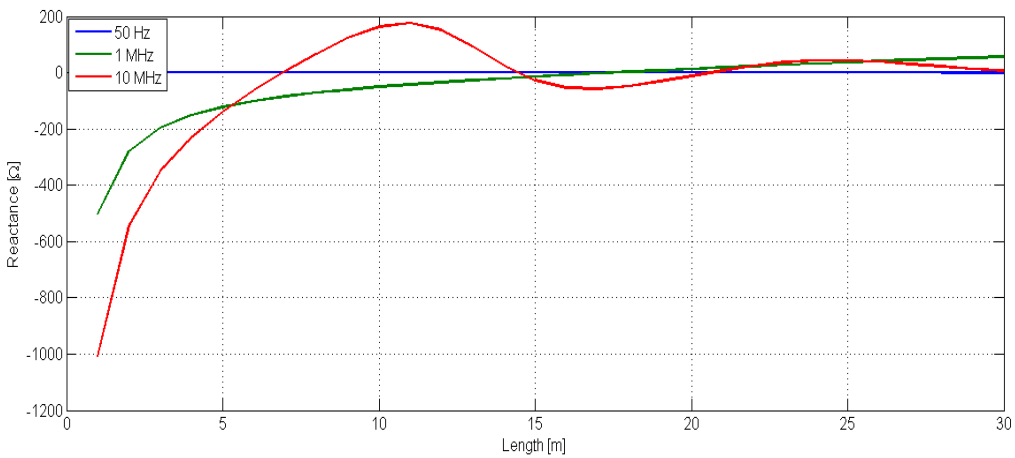


**Figure 5.13 Resistance of an earthing rod as a function of its length (soil resistivity = 100 Ohmm,  $\epsilon_r = 1$ )**

The same simulation was performed in the soil with resistivity equal to 3000 Ohmm. Corresponding curves are presented in Figure 5.14. These curves confirm that rods longer than 20 meters are not an efficient way of grounding. Reactance of the electrode is plotted as a function of the length in Figure 5.15. Fluctuations in the resistance suggest that for some dimensions 10 MHz is a resonant frequency. Thus for example for an electrode approximately 14 metres long reactance is zero while the resistance is at its peak.



**Figure 5.14 Resistance of an earthing rod as a function of its length (soil resistivity = 3000 Ohmm,  $\epsilon_r = 1$ )**



**Figure 5.15 Reactance of an earthing rod as a function of its length (soil resistivity = 3000 Ohmm,  $\epsilon_r = 1$ )**

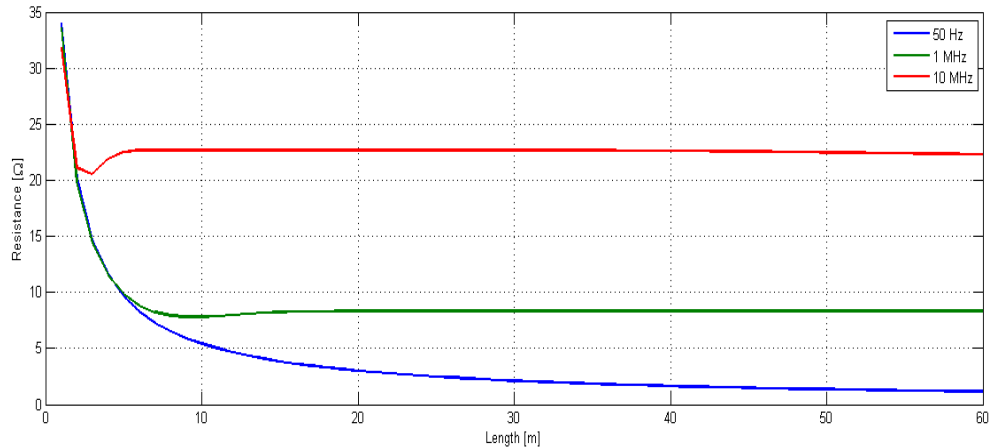
As can be seen from the figures above the most rapid changes happen between 1 and 10 meters. Based on this following length values can be suggested for the analysis:

**Table 5.2 Values for earthing rod's length suggested for simulations in CDEGS**

Length [m]	1, 2, 3, 4, 5, 6, 7, 8, 9, 10, 15, 20
------------	---------------------------------------

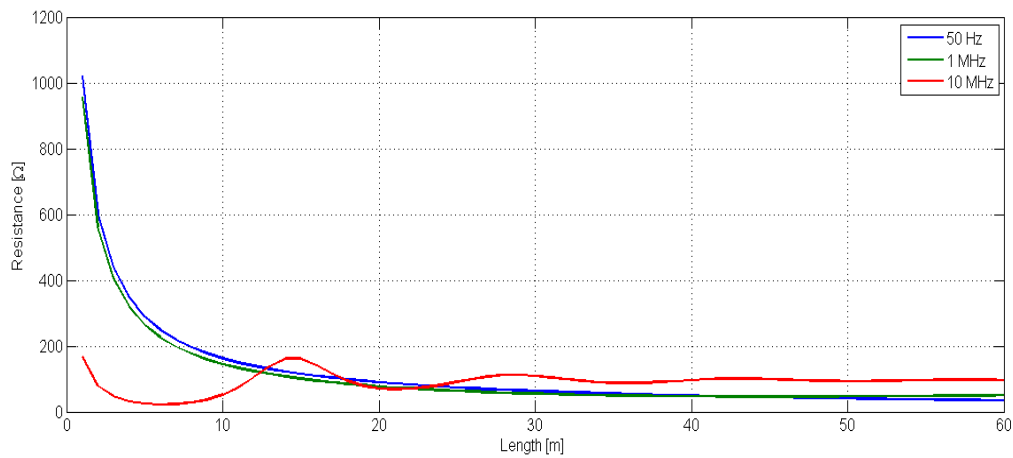
### 5.3.2. Counterpoise Grounding

According to the general recommendations given by Statnett [7, 9] the length of each radial in the counterpoise grounding should be at least 15 meters and should not exceed 30 meters. However if the conditions for grounding are poor near the tower, the length of each radial can be extended to 60 meters. The maximum allowed length is 80 meters. Figure 5.16 and 5.17 illustrate resistance to earth of a counterpoise grounding as a function of the length of each radial. Number of radials is 4 and burial depth is equal to 0.5 meters.

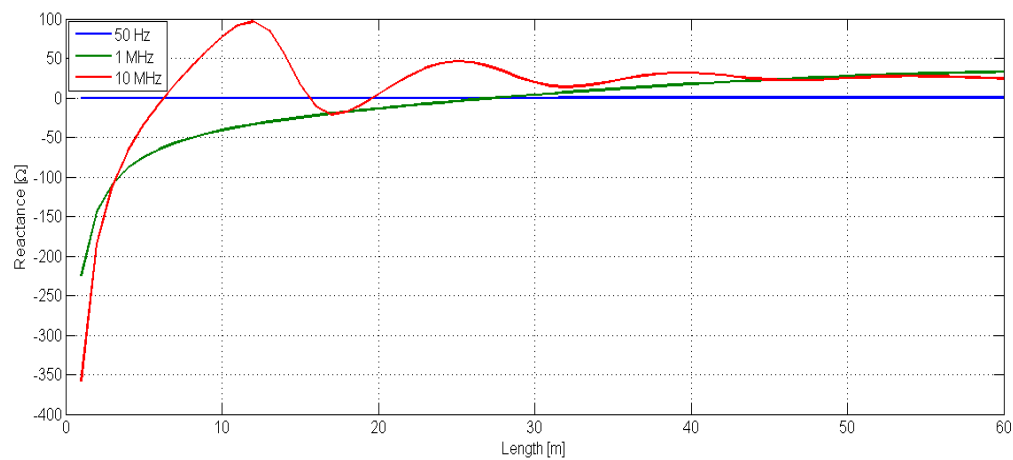


**Figure 5.16 Resistance of a counterpoise electrode as a function of its radial length (oil resistivity = 100 Ohmm, burial depth = 0.5 m,  $\epsilon_r = 1$ )**

There are oscillations in the curve at 10 MHz in the highly resistive soil. To illustrate the correlation between R and X, the reactance is plotted for this case as well (Figure 5.18). Same as for earthing rod, for some dimensions 10 MHz is a resonant frequency in this type of soil. For example for a radial length equal to approximately 15 m, reactance is zero, while there is a peak at the resistance curve.



**Figure 5.17 Resistance of a counterpoise electrode as a function of its radial length (oil resistivity = 3000 Ohmm, burial depth = 0.5 m,  $\epsilon_r = 1$ )**



**Figure 5.18 Reactance of a counterpoise electrode with 4 radials as a function of its radial length (soil resistivity = 3000 Ohmm, burial depth = 0.5 m,  $\epsilon_r = 1$ )**

Based on these curves the highest resolution should be between 1 and 20 meters. Values for the length suggested for analysis are listed in the Table 5.3.

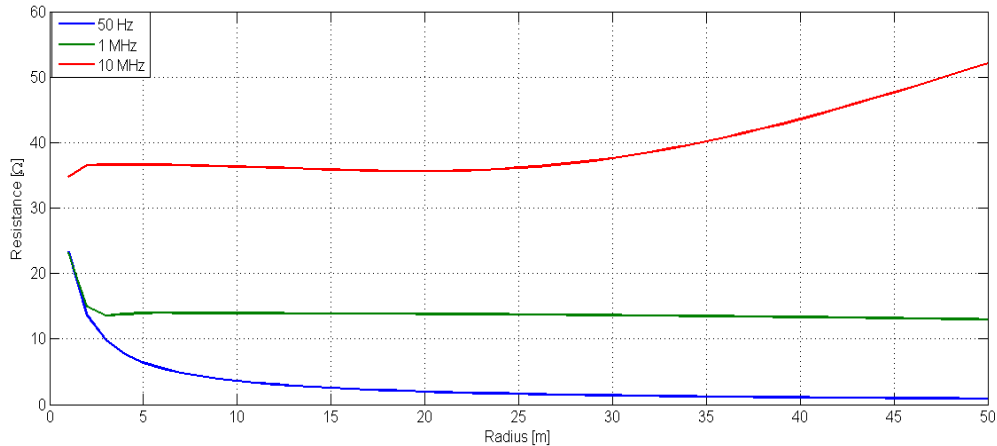
**Table 5.3 Values of radial length suggested fro simulations in CDEGS**

Length of a radial [m]	1, 2, 3, 5, 7, 10, 15, 20, 30, 50, 80 (11 points)
------------------------	---

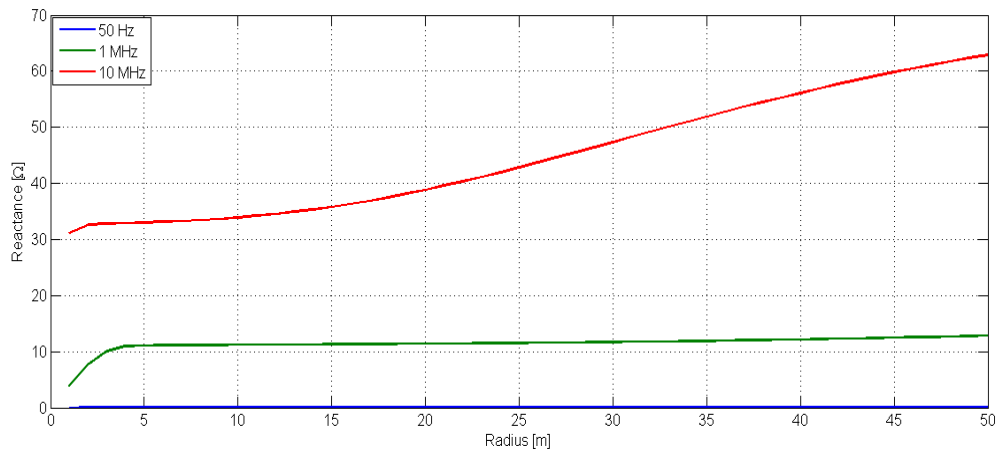


### 5.3.3. Ring Electrode

Figure 5.19 and 5.20 illustrate resistance and reactance of a ring electrode as a function of its radius in the soil with resistivity equal to 100 Ohmm. Radius of the ring was varied between 1 meter and 50 meters with 1 meter steps.

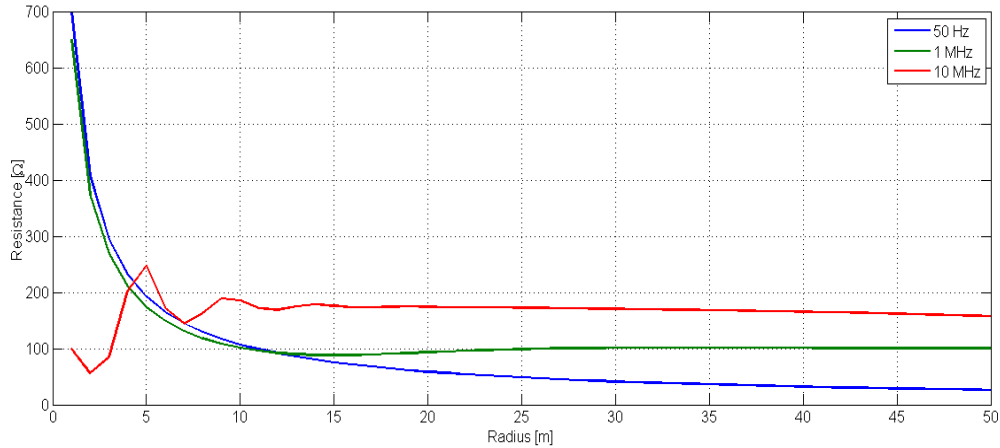


**Figure 5.19 Resistance of a ring electrode as a function of its radius (soil resistivity = 100 Ohmm, burial depth = 0.5 m,  $\epsilon_r = 1$ )**

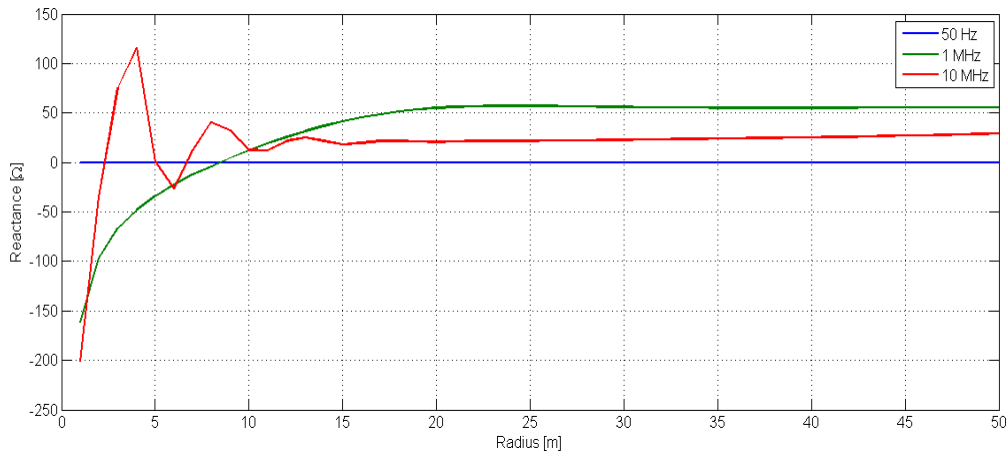


**Figure 5.20 Reactance of a ring electrode as a function of its radius (soil resistivity = 100 Ohmm, burial depth = 0.5 m,  $\epsilon_r = 1$ )**

The same model was analyzed in the soil with higher resistivity. The results are presented in Figure 5.21 and 5.22. Sharp edges in the 10 MHz response indicate that the resolution should be higher to achieve better accuracy.



**Figure 5.21 Resistance of a ring electrode as a function of its radius (soil resistivity = 3000 Ohmm, burial depth = 0.5 m,  $\epsilon_r = 1$ )**



**Figure 5.22 Reactance of a ring electrode as a function of its radius (soil resistivity = 3000 Ohmm, burial depth = 0.5 m,  $\epsilon_r = 1$ )**

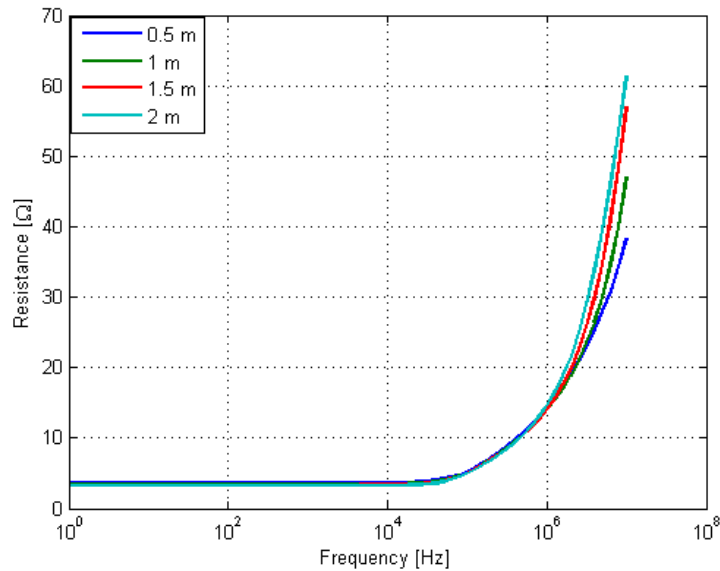
At low frequencies the most rapid changes happen when the radius is changed between 1 m and 10 m in soil with both good and poor conductivity. Red curves that correspond to 10 MHz frequency have different forms in soils with good and poor conductivity. In the first case, resistance at 10 MHz changes in the interval 25 meters to 50 meters. In the second case, however, rapid changes in the resistance occur for the shorter radius. This is also true for the imaginary part of the impedance to earth of this type of grounding.

Ring electrode is used when it is desirable to have the grounding close to the tower. Ring's possible dimensions are constrained by the dimensions of the tower since it is put into the earth around tower-feet, as shown in Figure 2.3. Since the main focus of this project is on tower-foot grounding, radius values will be varied between 1 and 10 meters, with 1 m step.

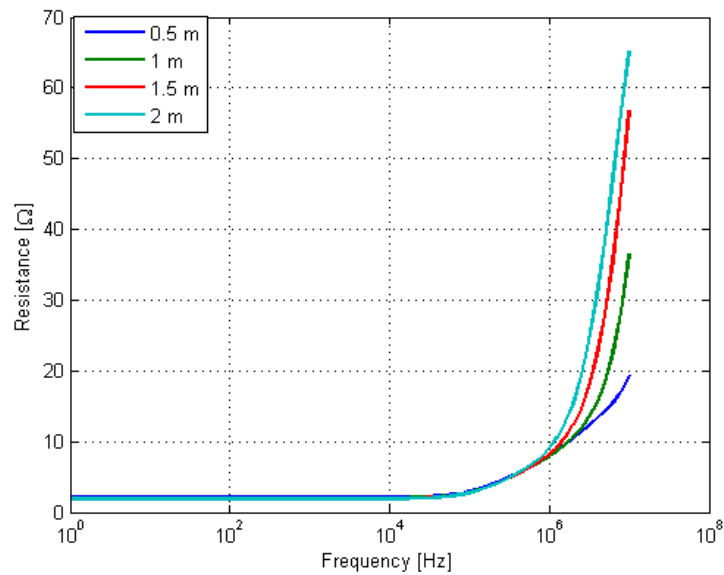
#### 5.4. Burial Depth

Horizontal electrodes can be buried into the soil at different depth. Counterpoise with four 30 meters long radials and ring electrode with radius equal to 10 m were used in simulations described in this chapter. Cross-sectional area for both electrodes is  $50 \text{ mm}^2$ .

Simulation performed in HIFREQ showed that the difference between the resistances at various depths is very small in highly conductive soil, but this difference increases with frequency. This is illustrated in Figure 5.23 and 5.24.

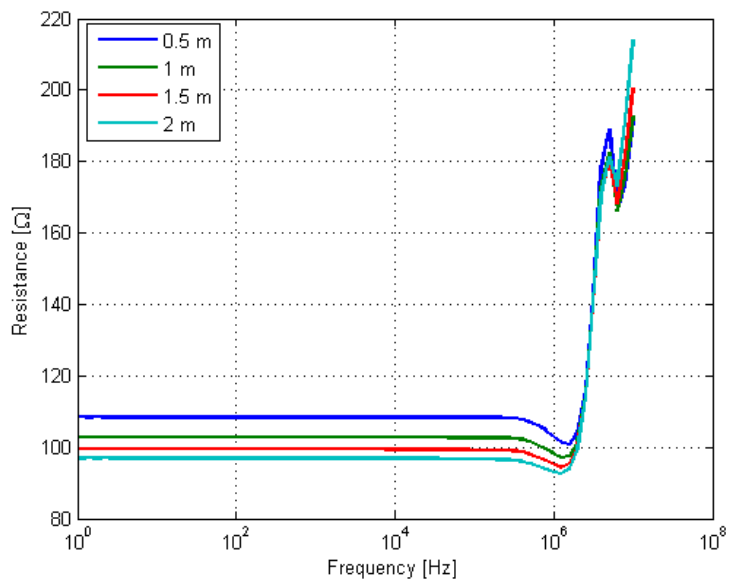


**Figure 5.23 Frequency response of a ring electrode buried into the soil at different depth (radius =10 m, burial depth =0.5, soil resistivity = 100 Ohmm,  $\epsilon_r = 1$ )**

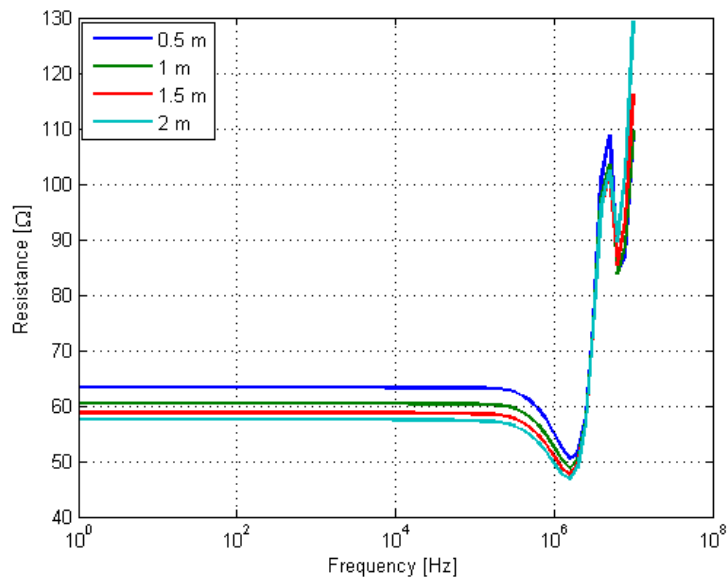


**Figure 5.24 Frequency response of a counterpoise electrode buried into the soil at different depth (radial length =30 m, burial depth =0.5, soil resistivity = 100 Ohmm,  $\epsilon_r = 1$ )**

In highly resistive soil the behaviour is different. It is characterized by larger difference in the low frequency region and negligible difference between 1 and 10 MHz. Figure 5.25 and 5.26 give examples of a ring and counterpoise electrode behaviour in the soil with resistivity of 3000 Ohmm.



**Figure 5.25 Frequency response of a ring electrode buried into the soil at different depth (radius =10 m, burial depth =0.5, soil resistivity = 3000 Ohmm)**



**Figure 5.26 Frequency response of a counterpoise electrode buried into the soil at different depth (radial length =30 m, burial depth =0.5, soil resistivity = 3000 Ohmm)**

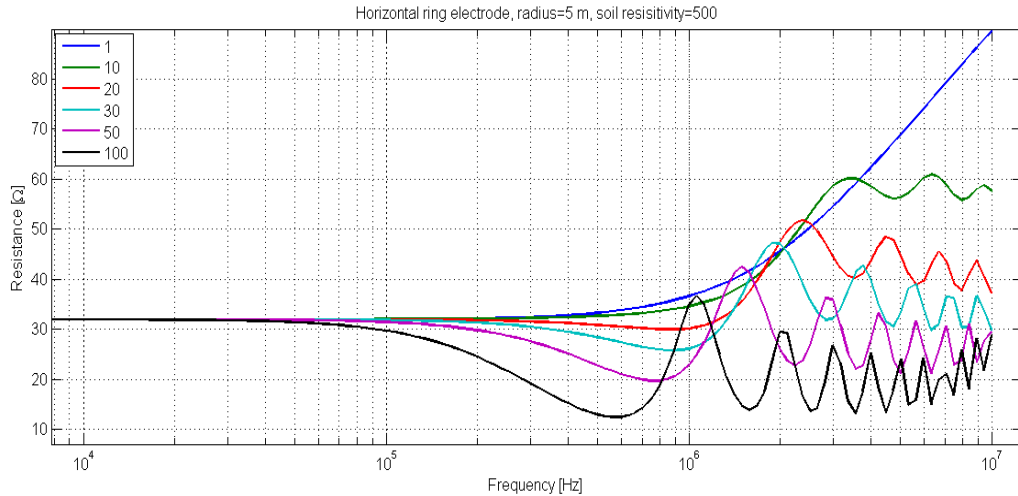
There are considerable differences between high frequency resistance in some cases, which indicate that burial depth cannot be disregarded, but due to time and resource limitations in these project only electrodes buried at 0.5 and 1 meter depth will be analyzed.

## 5.5. Soil Permittivity

To investigate how relative permittivity affects impedance to earth of a grounding electrode, several simulations were performed for the three electrode configurations.

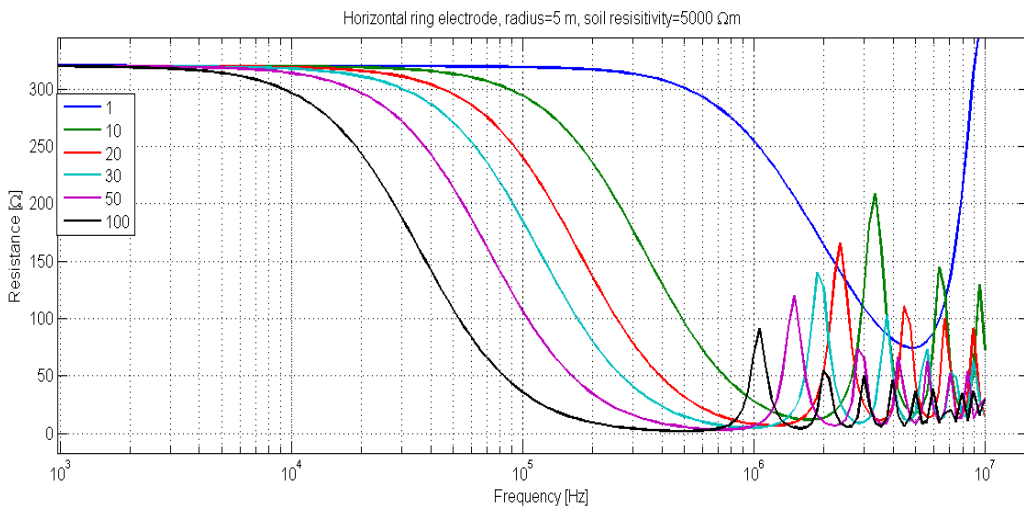
### 5.5.1. Case 1

Figures below show frequency response of a horizontal ring electrode in soil with different resistivity. Frequency resolution used in the following simulations is 40 frequency points per decade. Figure 5.27 presents responses obtained for soil resistivity equal to 500 Ohmm and different values of relative permittivity.

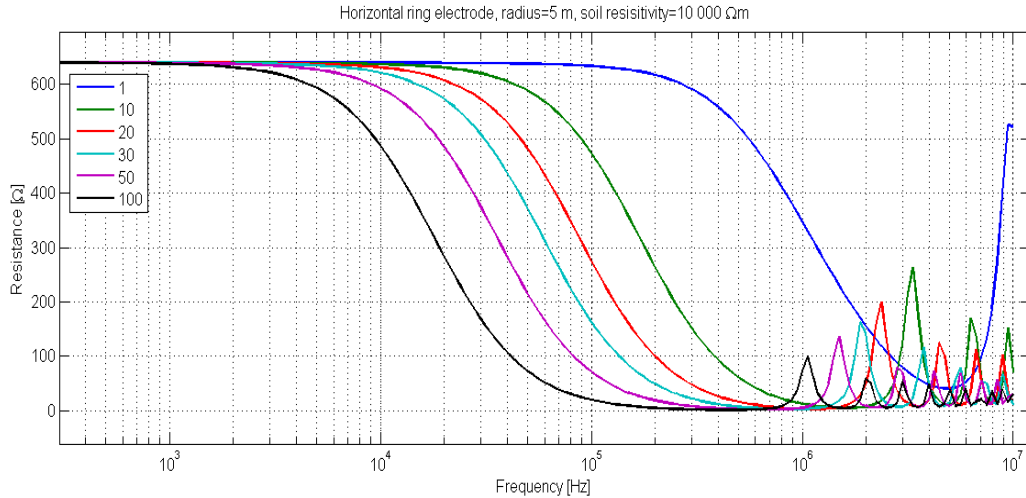


**Figure 5.27 Resistance of a ring electrode as a function of frequency in soil with different values of relative permittivity (radius =5 m, burial depth =0.5 m, soil resistivity = 500 Ohmm)**

Figure 5.28, 5.29 and 5.30 show the results for soil resistivity equal to 5000, 10000 and 50000 Ohmm respectively. Comparing these results one can conclude that high –frequency resistance becomes lower with increase in relative permittivity. In highly resistive soil, the amplitude of oscillations becomes smaller with increasing permittivity, but number of peaks becomes higher.

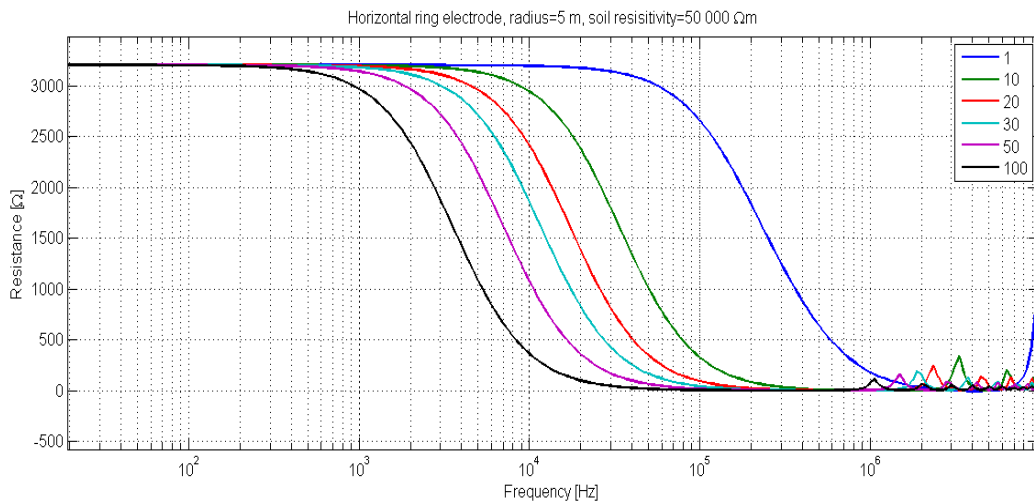


**Figure 5.28 Resistance of a ring electrode as a function of frequency in soil with different values of relative permittivity (radius =5 m, burial depth =0.5 m, soil resistivity = 5000 Ohmm)**



**Figure 5.29 Resistance of a ring electrode as a function of frequency in soil with different values of relative permittivity (radius =5 m, burial depth =0.5 m, soil resistivity = 10000 Ohmm)**

In soil with better conductivity resistance to earth at high frequency is still higher than power-frequency resistance. However, for higher resistivity values high-frequency resistance becomes lower than power-frequency resistance. In highly conductive soil the amplitude of oscillations at high frequencies becomes larger with increase in relative permittivity. This is exactly the opposite of what happens in the soil with poor conductivity.

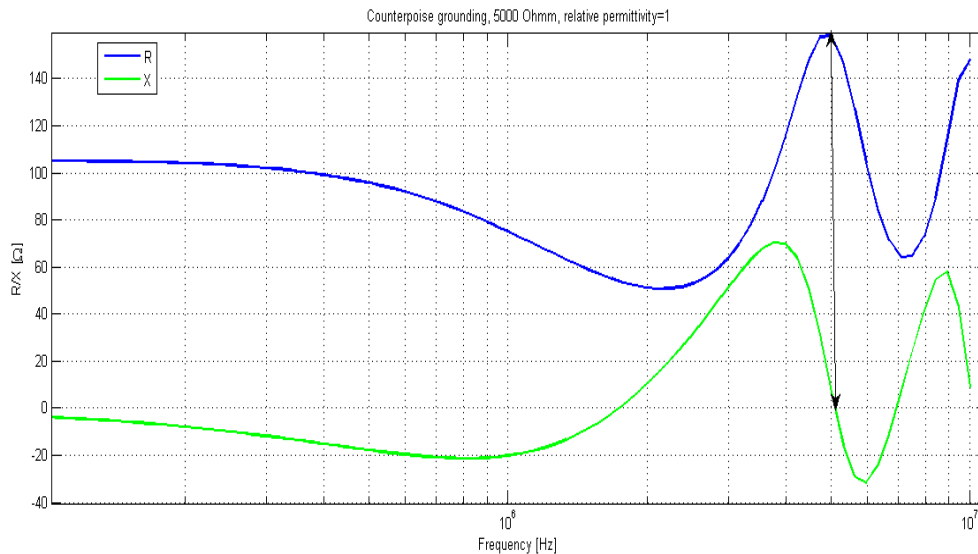


**Figure 5.30 Resistance of a ring electrode as a function of frequency in soil with different values of relative permittivity (radius =5 m, burial depth =0.5 m, soil resistivity = 50000 Ohmm)**

The same behaviour was observed for the other two electrode configurations. Frequency responses of earthing rod and counterpoise grounding can be found in Appendix A.

### 5.5.2. Case 2

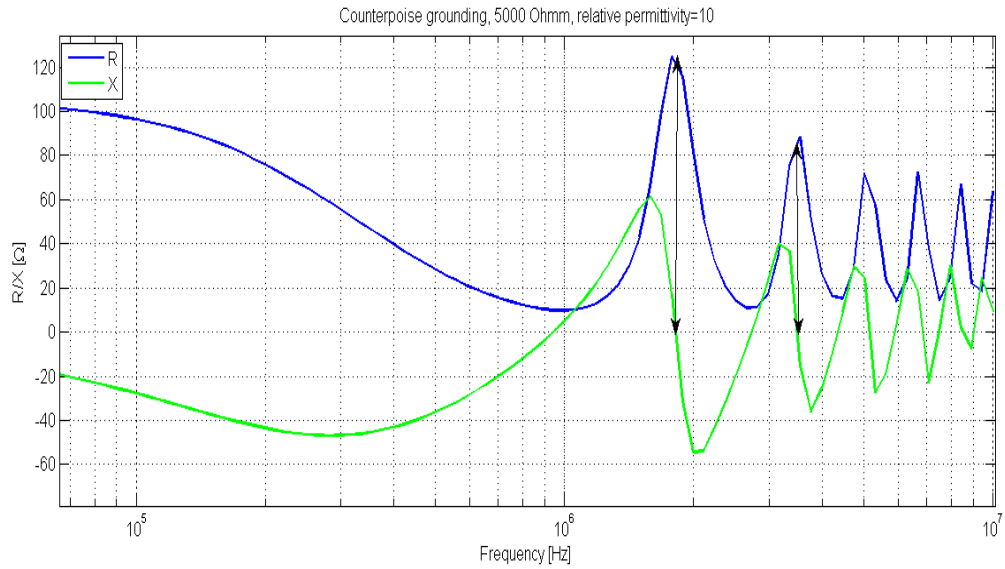
Figures below illustrate response of both real and imaginary part to changes in frequency. Counterpoise grounding with 30 metres long radials is used as an example. As expected, changes in the imaginary part start to occur after the frequency has passed 0.1 MHz. Therefore only interval between 0.1 MHz and 10 MHz is shown in the examples below. Figure 5.31 shows real and imaginary part of the impedance to earth of the ground electrode in the soil with  $\rho = 5000 \text{ Ohmm}$ , and  $\epsilon_r = 1$ . The reactance switches between capacitive and inductive and clear resonance peaks can be observed in the resistance. The top at the resistance curve occurs exactly at the same time when the reactance crosses zero. This is indicated with an arrow in Figure 5.31 .



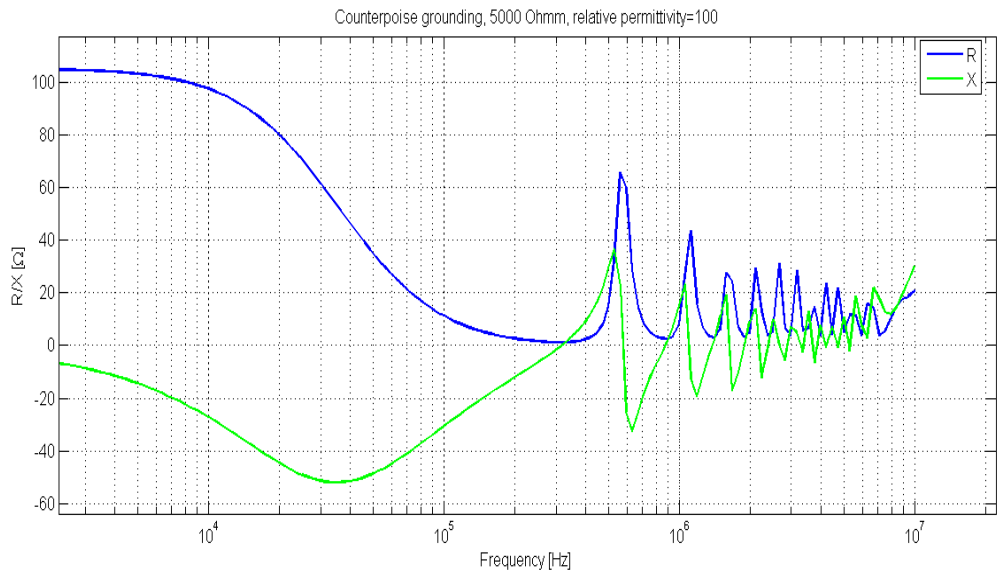
**Figure 5.31 Real and imaginary part of impedance to earth of a counterpoise ground electrode (radial length = 30 m, burial depth = 0.5 m, soil resistivity = 500 Ohmm,  $\epsilon_r = 1$ )**

Figure 5.32 and 5.33 illustrate results for relative permittivity equal to 10 and 100 respectively. Similarly to the case with  $\epsilon_r = 1$ , reactance in these two cases switches between capacitive and inductive and resonance peaks can be observed in the resistance at frequencies which give zero reactance.





**Figure 5.32 Real and imaginary part of impedance to earth of a counterpoise ground electrode (radial length = 30 m, burial depth = 0.5 m, soil resistivity = 5000 Ohmm,  $\epsilon_r = 10$ )**

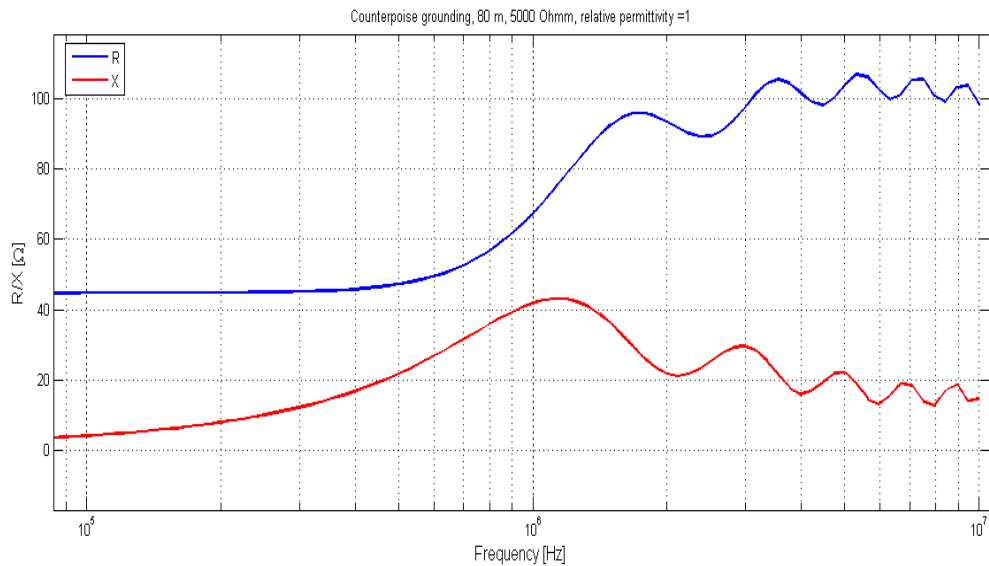


**Figure 5.33 Real and imaginary part of impedance to earth of a counterpoise ground electrode (radial length = 30 m, burial depth = 0.5 m, soil resistivity = 5000 Ohmm,  $\epsilon_r = 100$ )**

The sharp edges on the curves for permittivity of 10 and 100 suggest that the resolution should be higher.

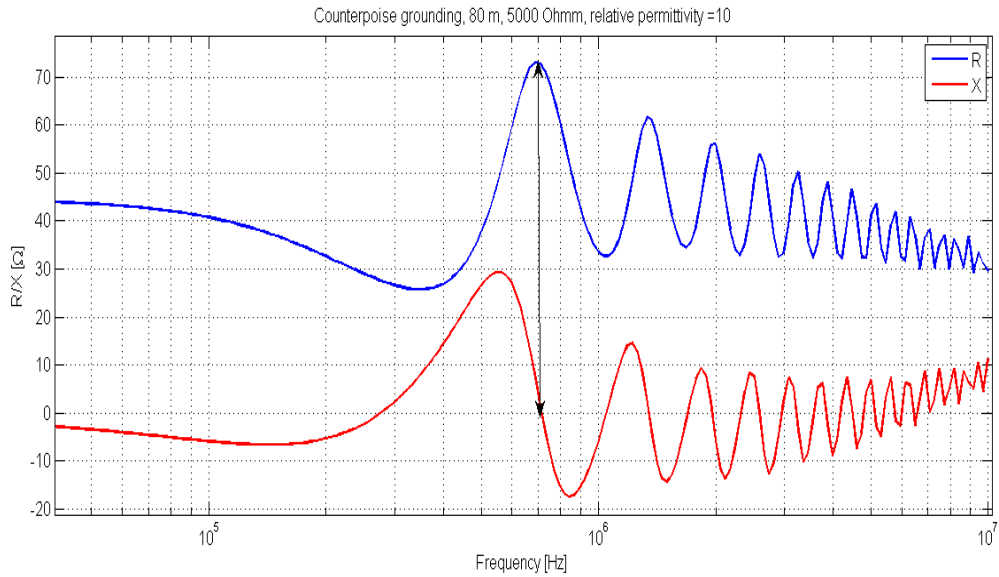
### 5.5.3. Case 3

Another example is counterpoise grounding with very large extension. Counterpoise electrode with 80 m long radials buried at 0.5 meter depth was analyzed in the soil with resistivity equal to 5000 Ohmm and relative permittivity as a parameter. Figure 5.34 shows the results for permittivity equal to 1. The simulations are performed with 40 frequency points per decade. For these geometrical dimensions high-frequency resistance was higher than resistance at power-frequency.



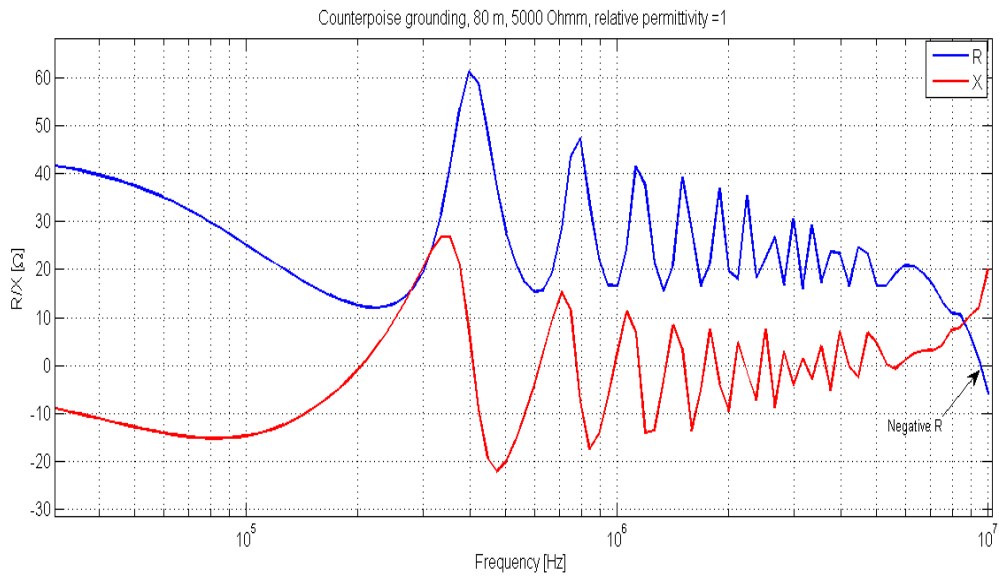
**Figure 5.34 Real and imaginary part of impedance to earth of a counterpoise ground electrode (radial length = 80 m, burial depth = 0.5 m, soil resistivity = 5000 Ohmm,  $\epsilon_r = 1$ )**

Permittivity affects impedance to earth of a ground electrode only at frequencies above 0.1 MHz with the most apparent changes between 1 MHz and 10 MHz. There are clear resonances in these responses as well. An arrow in Figure 5.35 denotes an example of a resonance peak.



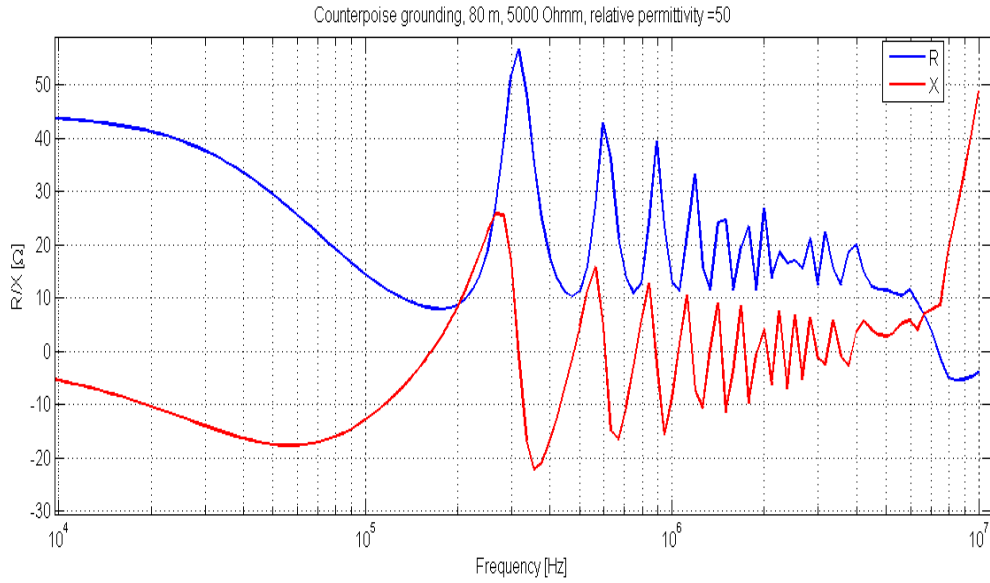
**Figure 5.35 Real and imaginary part of impedance to earth of a counterpoise ground electrode (radial length = 80 m, burial depth = 0.5 m, soil resistivity = 5000 Ohmm,  $\epsilon_r = 10$ )**

When the permittivity has reached 30, the resistance value becomes negative after the frequency has passed approximately 8 MHz as showed in Figure 5.36. This fact indicates that there must be some limitations in the program that lead to the fault in computation results.

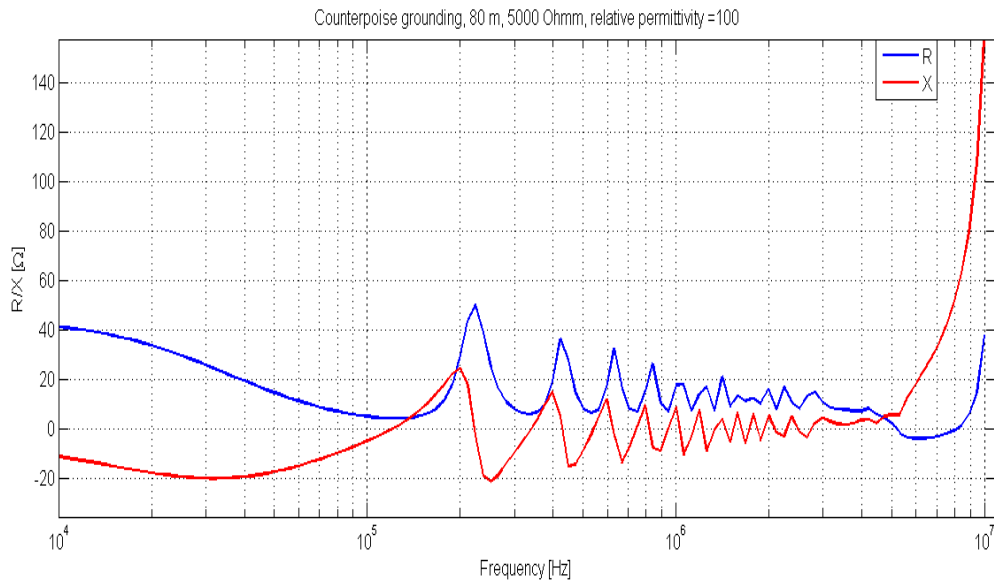


**Figure 5.36 Real and imaginary part of impedance to earth of a counterpoise ground electrode (radial length = 80 m, burial depth = 0.5 m, soil resistivity = 5000 Ohmm,  $\epsilon_r = 30$ )**

The same happens in the soil with relative permittivity equal to 50 and 100, which is illustrated by Figure 5.37 and 5.38 respectively.



**Figure 5.37 Real and imaginary part of impedance to earth of a counterpoise ground electrode (radial length = 80 m, burial depth = 0.5 m, soil resistivity = 5000 Ohmm,  $\epsilon_r = 50$ )**



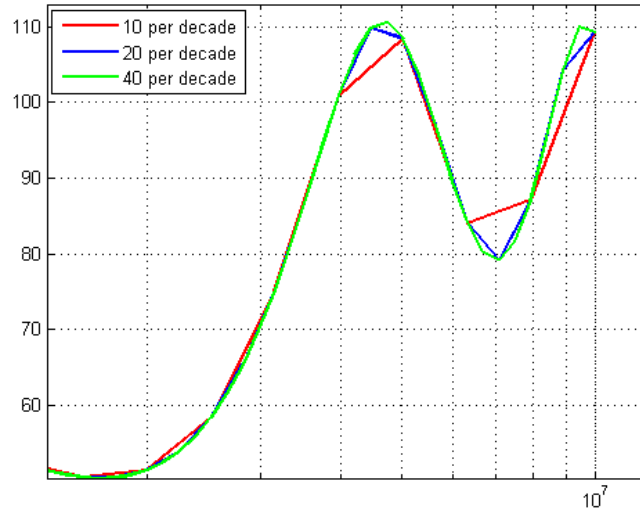
**Figure 5.38 Real and imaginary part of impedance to earth of a counterpoise ground electrode (radial length = 80 m, burial depth = 0.5 m, soil resistivity = 5000 Ohmm,  $\epsilon_r = 100$ )**

#### 5.5.4. Recommended Values

According to [10], typical value of relative permittivity in the soil equals to 10. This value is also referred to as a median value of the soil's relative permittivity in [16]. It is desirable to cover a wide range of parameters in the database, based on this the highest value is set to 100. The results described in this subchapter suggest that it is beneficial to have high resolution for relative permittivity for results to be as accurate as possible at high frequencies, but due to time constraints in this project electrodes will be simulated only in the soil with relative permittivity equal to 1, 10 and 100.

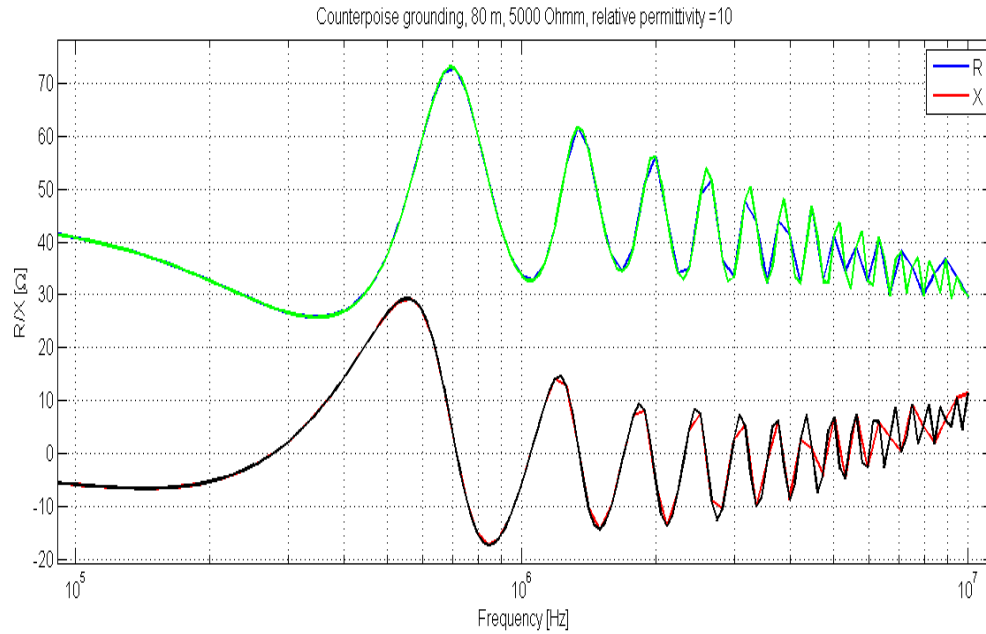
## 5.6. Frequency Resolution

Figure 5.39 represents magnified picture of the curves obtained for a counterpoise grounding (30 metres long radials) in the soil with  $\rho=3000$  Ohmm, and  $\epsilon_r=1$ . Comparison of the red curve (10 point per decade) and the green curve (40 points per decade) shows that the accuracy of the results is improved in the high frequency region by using higher frequency resolution in the simulations. However, one should keep in mind that the simulation time increases with the number of frequencies analyzed.



**Figure 5.39 Resistance of a counterpoise electrode with different frequency resolution**

The results in chapter 5.5 revealed that 40 frequency points per decade is not sufficient resolution in the last decade (1 MHz to 10 MHz). Additional simulations were carried out with 80 points per decade. In Figure 5.40 green and black curves are real and imaginary parts of the impedance to earth of a counterpoise grounding simulated with 80 frequency points per decade, while blue and red curves are obtained with frequency resolution of 40 points per decade. These results prove that between 1 MHz and 10 MHz 80 points per decade give better accuracy, but it is not necessary to use such high resolution for lower frequency range since the curves are identical for frequencies up to 0.1 MHz.



**Figure 5.40 Real and imaginary part of impedance to earth of a counterpoise ground electrode with frequency resolution equal to 40 and 80 points per decade (radial length = 80 m, burial depth = 0.5 m, soil resistivity = 5000 Ohmm,  $\epsilon_r = 10$ )**

Based on the obtained results and in order to keep simulation time at minimum it is suggested to use following resolution for frequency:

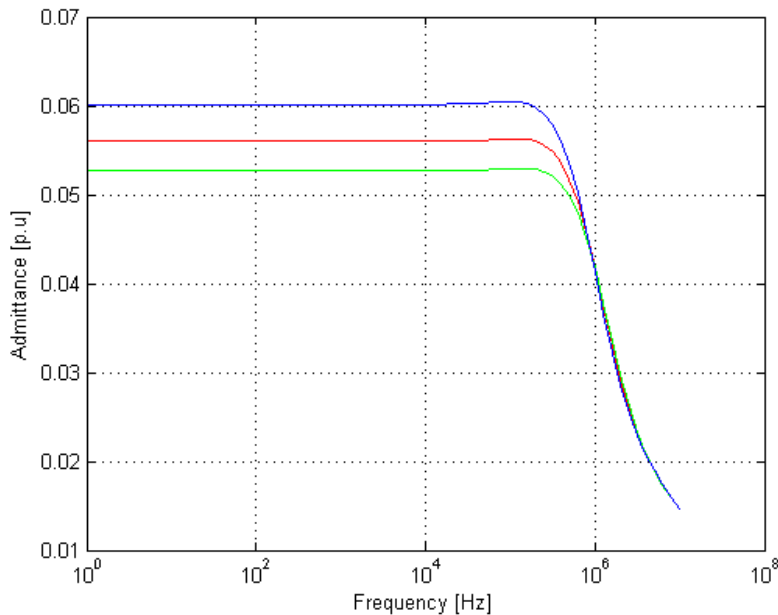
**Table 5.4 Frequency resolution for CDEGS simulations**

1 Hz to 0.1 MHz	10 points per decade
0.1 MHz to 1 MHz	40 points per decade
1 MHz to 10 MHz	80 points per decade

## 5.7. Interpolation

Since the database is constructed for a limited number of points, interpolation is required for the values between those points. If the pole - residue model is stored for each combination of parameters, the first suggestion is to interpolate between poles and residues of the corresponding points. This method however appeared to be unsuitable. For some points result of interpolation was satisfying, but in some cases interpolated poles and residues did not give the supposed result. Two examples are shown below. Red curves in Figure 5.41 and 5.42 correspond to the interpolated admittance of the system as a function of frequency.

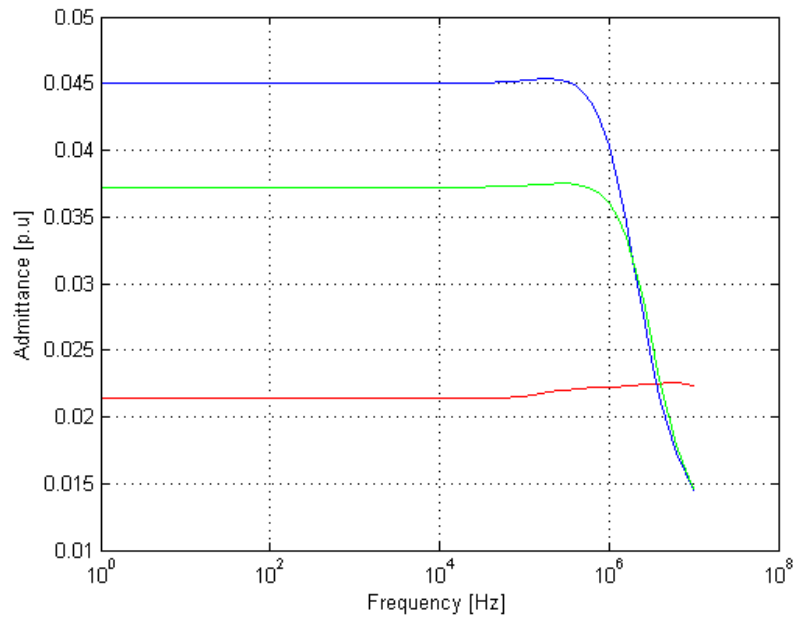
The curves for 6 and 7 metres long earthing rod were obtained by simulation in CDEGS and vector fitting, while the graph for a 6.5 metres long earthing rod is built with the use of interpolated poles and residues. In this case the result appears to be satisfying.



**Figure 5.41 Admittance of a 6.5 m long earthing rod as a function of frequency obtained by interpolation between poles and residues for 6 and 7 m long earthing rods**

For 4.5 metres long earthing rod, however, interpolated curve was completely different from the curves obtained for 4 and 5 metres long rods.





**Figure 5.42 Admittance of a 4.5 m long earthing rod as a function of frequency obtained by interpolation between poles and residues for 4 and 5 m long earthing rods**

It has been observed that when the poles are situated far apart from each other the interpolated poles and residues did not give correct admittance. The same yields if frequency response curve for one parameter has only real poles and the other one has both real and complex poles.

These results suggest that the best method is to interpolate between admittance values, and perform vector fitting on the interpolated response curve.

## 5.8. Discussion

Soil resistivity affects impedance to earth of a ground electrode in different ways depending on the frequency. In the low frequency range resistance to earth is proportional to the soil resistivity. Relationship between soil resistivity and resistance of a ground electrode is non-linear at high frequencies. At which frequency this relationship becomes non-linear depends on the electrode configuration, for example for an earthing rod this frequency is higher than for ring and counterpoise grounding. Relative permittivity of the soil also affects response of the ground electrode resistance to changes in the soil resistivity. For higher values of relative permittivity relationship between resistance and resistivity becomes non-linear at lower frequencies. Increase in permittivity also results in resistance being less affected of changes in soil resistivity after a certain value. Simulations in CDEGS showed in some cases (Figure 5.4 and 5.6) that high – frequency resistance decreased slowly with increasing resistivity (for values higher than 1000 Ohmm). There is a possibility that results from simulations cannot be considered completely reliable since there are some limitations in computational method in the software and realistic behaviour of a ground electrode cannot be acquired at such high frequencies without modelling the whole system.

Simulation results indicate that cross-sectional area of a conductor has little influence on the impedance to earth of a ground electrode at high frequencies. Therefore it is set to a fixed value in the simulations for these electrodes.

As mentioned in Chapter 2 grounding devices have effective dimensions when it comes to dissipation of high-frequent impulse current. At high frequencies the inductance of the conductor will hinder current from flowing to the far part of the grounding system so it would not be used completely. Thus, while power-frequency resistance will continue to decrease with increasing extension, high - frequent resistance will remain the same after some point. From the results presented in 5.3 it is obvious that power-frequency resistance decreases with increase in electrode geometrical dimensions (length or radius), though the rate of change becomes slower with increasing dimensions. At high frequencies, however, the curves demonstrate saturation trend for lower values of geometrical dimensions.

Burial depth affects resistance to earth in different ways depending on the value of soil resistivity. Experimental results in [17] showed that impulse grounding impedance decreases with the increase of burial depth, and there is an effective burial depth for horizontal electrodes. Results from simulations in CDEGS suggest that there is a limit for burial depth after which the decrease in resistance to earth is very little and further increase in burial depth is an ineffective way of reducing resulting resistance to earth.

Relative permittivity in the soil affects imaginary part of the impedance to earth. Swings in reactance result in the resonance peaks in the resistance. Number of resonance peaks increases with increasing permittivity in the cases that were analyzed.

It has been observed that the response of an electrode to high frequent current can contain negative values of the resistance. This often happens in the soil with high values of resistivity or permittivity. However, there was not revealed any exact pattern for when negative values of the resistance occur. Support team at Safe Engineering Services and Technologies gave the following explanation: "The real part of the GPR of the conductor should not necessarily be a positive quantity at high frequencies. This expectation is based on considerations of the total power loss in the conductor and the medium. However, the interaction between conductors and the field in the near field of the conductors (especially, close to the energization point) is a complex phenomenon that can be strongly dependent on the return path of the current. At low frequencies the situation is different. Since the wavelength is very large, the field distribution is almost homogenous around the energization point and one can assume that the return electrodes are placed at infinity. In order to get full physical picture at high frequencies one would need to model the entire system, including the return path of the current."

Linear interpolation is considered to be a suitable computation method for frequency response of a ground electrode. Interpolation between poles and residues has been proved to be unsuitable as the results differs greatly from case to case. In addition to that, interpolated model might not be passive since no passivity enforcement will be conducted.

## 6. Results

### 6.1. Electrode Modelling in CDEGS

As was mentioned before, three types of ground electrodes were analyzed during the project: earthing rod, counterpoise grounding with four radials and horizontal ring electrode. Electrode models are shown in Figure 6.1, 6.2 and 6.3.

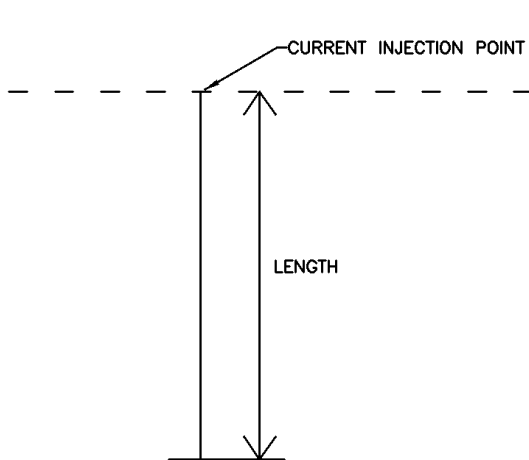


Figure 6.1 Model of an earthing rod

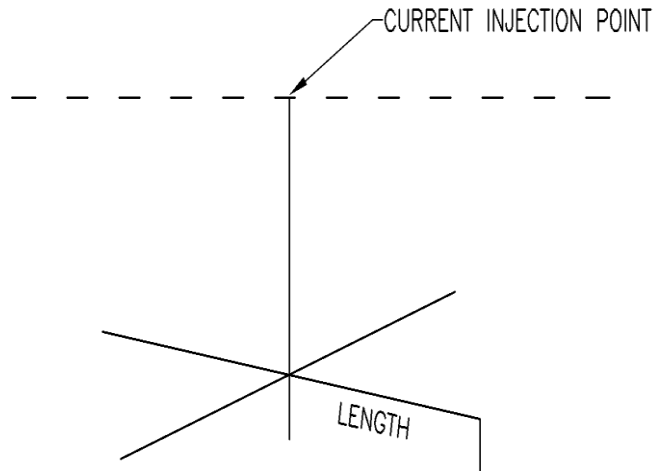


Figure 6.2 Model of a counterpoise grounding

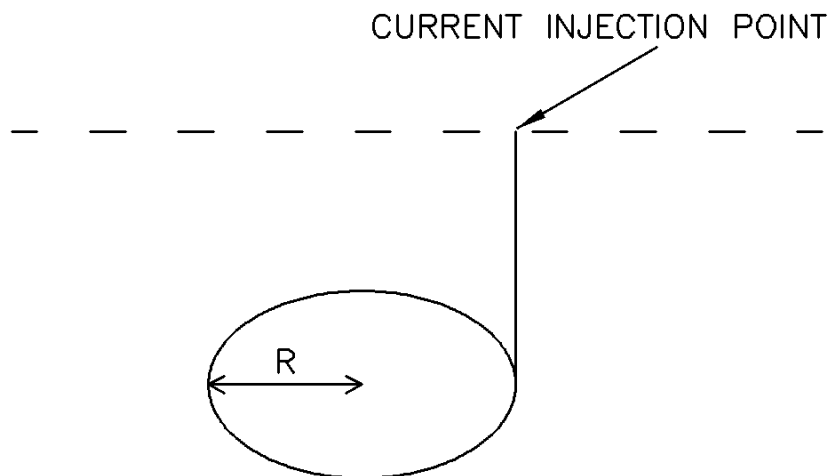


Figure 6.3 Model of a horizontal ring electrode

A uniform soil model with variable values of resistivity and relative permittivity was used in all simulations. Conductors were modelled as bare copper conductors. Parameters presented in Table 6.1 were determined based on the results from Chapter 5.

**Table 6.1 Parameters used in CDEGS simulations**

<b>Parameter</b>	<b>Values used in CDEGS-simulations</b>
Soil resistivity [Ohmm]	100, 300, 500, 1000, 1500, 2000, 3000, 4000, 5000, 10000, 15000, 20000, 30000, 50000
Relative permittivity	1, 10, 100
Length (earthing rod) [m]	1, 2, 3, 4, 5, 6, 7, 8, 9, 10, 15, 20
Length of a radial (counterpoise grounding) [m]	1, 2, 3, 5, 7, 10, 15, 20, 30, 50, 80
Radius (horizontal ring electrode) [m]	1, 2, 3, 4, 5, 6, 7, 8, 9, 10
Burial depth (for counterpoise and ring electrodes) [m]	0.5, 1

Input files for all possible combinations of these parameters were prepared using SESScript. Appendix B contains text files used in SESScript for generating input files for HIFREQ engineering module.

Unit current at different frequencies was injected through a 0.1 meter long copper conductor. Ground potential rise (GPR) of this conductor, which is equal to impedance to earth of the ground electrode, was extracted in the text format from HIFREQ. An example of an output report is presented in Appendix C. SESBat tool in CDEGS was used to execute multiple simulations and acquire reports containing frequency response data. Appendix D describes the procedure for generating and processing multiple input files using SESScript and SESBatch tools in CDEGS software package.

Frequency resolution was determined in chapter 5.6. Frequency points in the simulations are logarithmically spaced, total number of frequencies is 171 with the highest resolution between 1 and 10 MHz. Frequencies used in the analysis are listed in the text files available in Appendix B. Note that in the actual simulations it was necessary to set the highest frequency 1 Hz lower in order to be able to display it in the output report. Frequencies from 10 MHz and higher are displayed as '\*\*\*\*\*Hz' in the text report and this leads to problems when reading the files with the help of Matlab. Safe Engineering Services and technologies ltd. are working on this case, but at the time of the project the problem was still not eliminated. Thus, the highest frequency is 9999999 Hz. It is not possible to set it to 9999999.9 because in this case the program rounds it up to 10 MHz.

An important aspect for simulations in HIFREQ is conductor segmentation. Long conductors should be subdivided into smaller segments for computation to be as correct as possible. A condition that should be satisfied is that the longest conductor segment should be no longer than about one sixth of the wavelength. Wavelength in the soil can be calculated using Eq. 20, where  $\lambda$  is the wavelength in m,  $\rho$  is the resistivity in Ohmm, and  $f$  is the frequency in Hz.

$$\lambda = 3160\sqrt{(\rho/f)} \quad (20)$$

The highest frequency for the simulations in this project is 10 MHz. Using the simplified formula (Eq.20) the shortest wavelength is equal to 10 m. Engineering manual recommends maximum segment length to be no longer than one sixth of the wavelength. This gives that the segments should be no longer than 1.67 m.

Electromagnetic Calculator is a tool available in CDEGS Software package for calculation of the wavelength at a given frequency and soil resistivity. Using electromagnetic calculator the wavelength can be calculated more precisely, and relative permittivity will be taken into consideration as well. Table 6.2 presents the results for wavelength and corresponding maximum segment length for several cases with different resistivity and permittivity. Computational frequency is 10 MHz.

**Table 6.2 Wavelength and corresponding maximum segment length in soil with different parameters**

Soil resistivity [Ohmm]		100	500	1000	2000	4000	5000
Relative permittivity = 1	Wave length [m]	9.7	19.5	24.25	27.7	29.3	29.5
	Maximum segment length [m]	1.61	3.25	4.04	4.61	4.88	4.91
Relative permittivity = 10	Wave length [m]	7.7	9.3	9.4	9.47	9.48	9.48
	Maximum segment length [m]	1.28	1.55	1.56	1.58	1.58	1.58
Relative permittivity= 100	Wavelength [m]	2.98	2.99	2.99	2.99	2.99	2.99
	Maximum Segment Length [m]	0.5	0.5	0.5	0.5	0.5	0.5

SESScript tool in CDEGS allows entering parameters and generating input files automatically. However, to assign values to number of segments to corresponding conductor length implies that the file names have to be entered manually for each case. Otherwise, SESScript generates input files for all possible combinations of parameters which results in unnecessary large number of input files and complicates the analysis. Taking this fact into consideration, segments should be no longer than 0.5 m to satisfy the requirement in all cases. HIFREQ simulations can be time requiring, and simulation time is highly dependent on the number of segments. To achieve sufficient accuracy in simulations and at the same time reduce simulation time the following solution is suggested: divide conductors in several groups depending on the length, and run simulations for these batches using different number of segments for them. Number of segments should be determined for the longest conductor in the group and the shortest possible wave length. Table 6.3 contains number of segments for configurations used in the database.

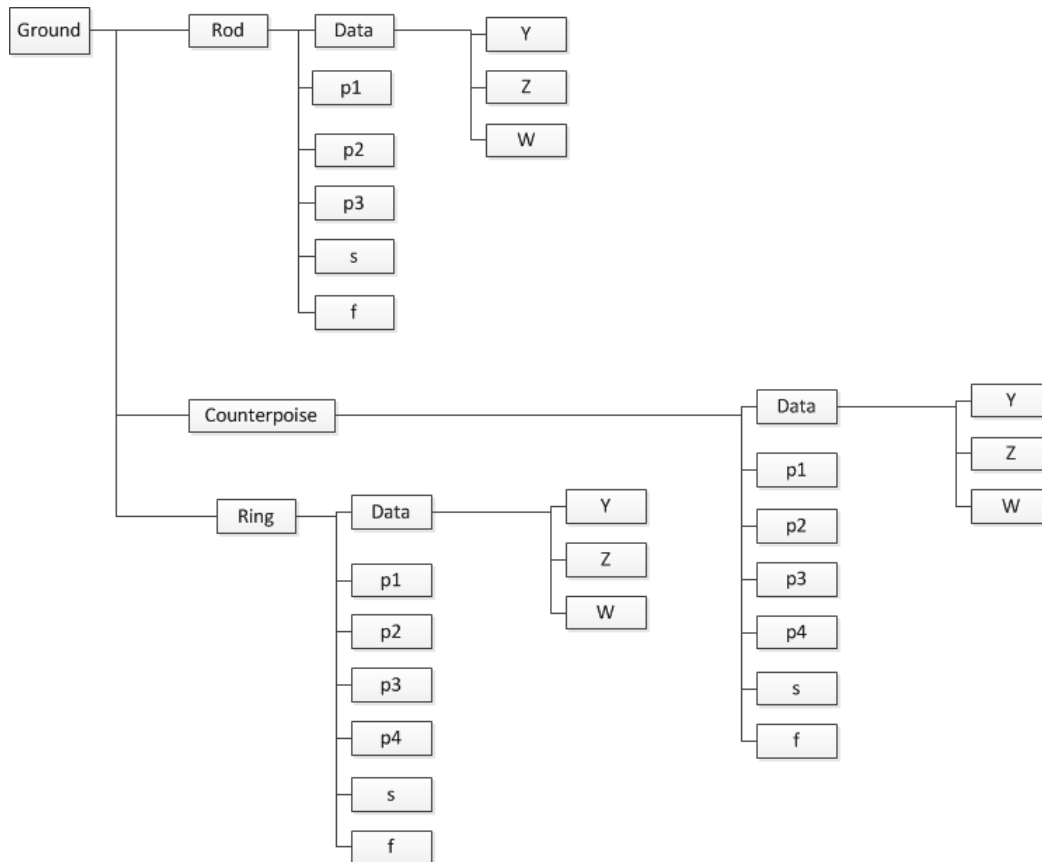
**Table 6.3 Segmentation of conductors in CDEGS**

Configuration	Number of segments
Earthing rod, 1 – 10 m	20
Earthing rod, 15 m	30
Earht rod, 20 m	40
Ring, all radius values	50
Counterpoise, 1-20 m	40
Counterpoise, 30, 50 and 80 m	60

For the two longest conductors, 50 and 80 metres long radial of the counterpoise grounding, number of segments should be set to 100 and 160 respectively. In this case the simulation time is extremely long. Due to time and resource limitations in the project counterpoise electrodes with 50 and 80 metres long radials are simulated with 60 segments per each radial. This leads to slightly different results for the highest frequencies when permittivity is equal to 100. However, the length of each segment in this case is 1.33 m, which satisfies the segmentation condition if one uses the simplified formula for wavelength (Eq.20).

## 6.2. Structure Array

Values of impedance, phase angle, resistance and reactance were extracted from the text files. Admittance, absolute value of the impedance and impedance angle were stored in the structure array (*Ground.mat*) for each case. *Ground.mat* is a structure array with three fields: “Rod”, “Counterpoise”, and “Ring”. Each substructure contains fields with frequency response data, and parameters used in the simulations. Layout of this structure is shown in Figure 6.4. Field Data contains admittance of the system (Y), absolute value of the impedance (Z), and impedance angle (W). Fields p1, p2, p3, p4 contain relative permittivity, soil resistivity, geometrical dimensions of the electrodes, and burial depth respectively. Frequency in Hz is stored in the field f, s is equal to  $j2\pi f$ .



**Figure 6.4 Structure array in Matlab**

Matlab script developed to extract values from the reports and store them in a structure array is available in Appendix E.

### 6.3. Function *interfit.m*

The function *interfit* finds ground electrode with given parameters, extracts its frequency response from database or linearly interpolates between two frequency responses if one or several of the input parameters are not present in the database. This is achieved by using Matlab function *interp*. As a second step, the function calls vector fitting. A pole-residue model for a given data set is generated by *VFdriver.m* and passivity of this model is enforced by *RPdriver.m* [24]. *Interfit.m* returns SER - structure containing poles and residues of the model. In addition *interfit* plots admittance as a function of frequency (original, approximated by vector fitting and perturbed model after passivity enforcement).

The following function call in Matlab will provide the necessary output.

```
[SER]=interfit (type, P1, P2, P3, P4)
```

#### **Input parameters:**

`type` –type of the electrode (1 - earthing rod, 2 - counterpoise grounding with four radials, 3 - horizontal ring electrode)



P1 – relative permittivity of the soil

P2 – soil resistivity

P3 – length or radius of the electrode, depending on its type (Note that for the counterpoise grounding length is a dimension of a single radial, as shown in Figure 6.2.)

P4 – burial depth of the horizontal electrode (for counterpoise and ring grounding)

**Output:**

SER – the perturbed model, on pole residue form and on state space form

Only P1,P2 and P3 are required for type 1. Type 2 and 3 require all four parameters to be passed to the function.

Note that order of approximation in vector fitting is set to 5 in the function, sometimes however this order is too low to obtain good approximation, and in this case opts.N in interfit.m should be changed to a higher value before calling the function.

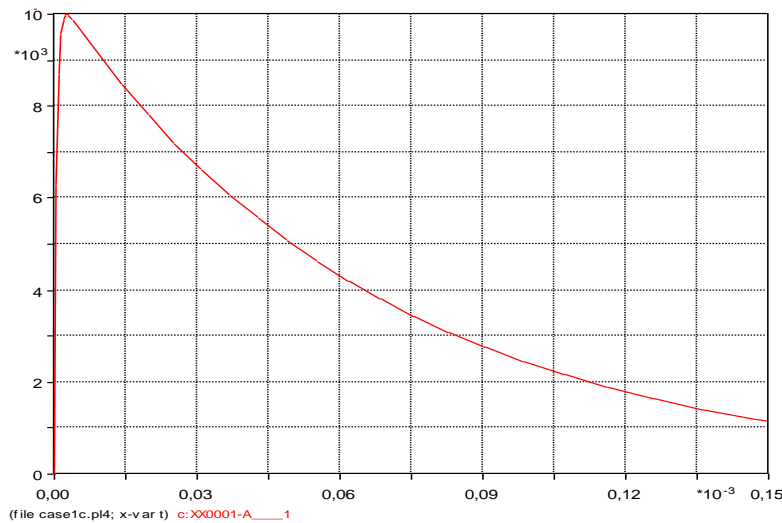
Extrapolation with this function is not possible; a warning appears on the screen when a parameter is beyond the limits. New values should be passed to the function in this case. Matlab source code for the function is presented in Appendix F.

.

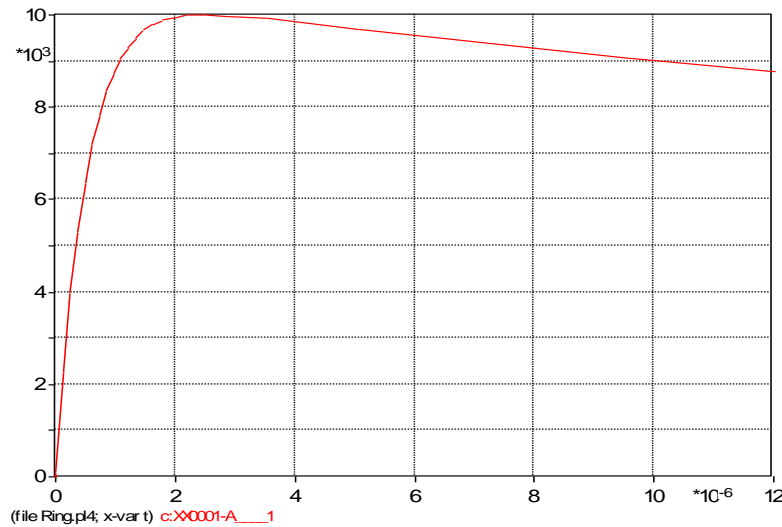
## 6.4. Analysis of Response Accuracy

### 6.4.1. Impulse Current Description

Frequency - dependent model created with the help of vector fitting can be used in ATPDraw. Equivalent model for ATPDraw is created from SER-structure using Matlab routine *netgen\_ATP.m* [23]. It creates a text file which can be exported to ATPDraw. Corresponding models of the ground electrodes were created in HIFREQ. Main goal of these simulations was to verify that models of a ground electrode in CDEGS and ATPDraw respond similarly to the same impulse current. Ground electrodes were energized with  $1.2 \mu\text{s}/50\mu\text{s}$  impulse current with peak value equal to 10 kA, illustrated in Figure 6.5 and 6.6.



**Figure 6.5 Lightning current used in time domain simulations**



**Figure 6.6 Magnified picture of lightning current used in time domain simulations**

Several examples are presented in the following subchapters.

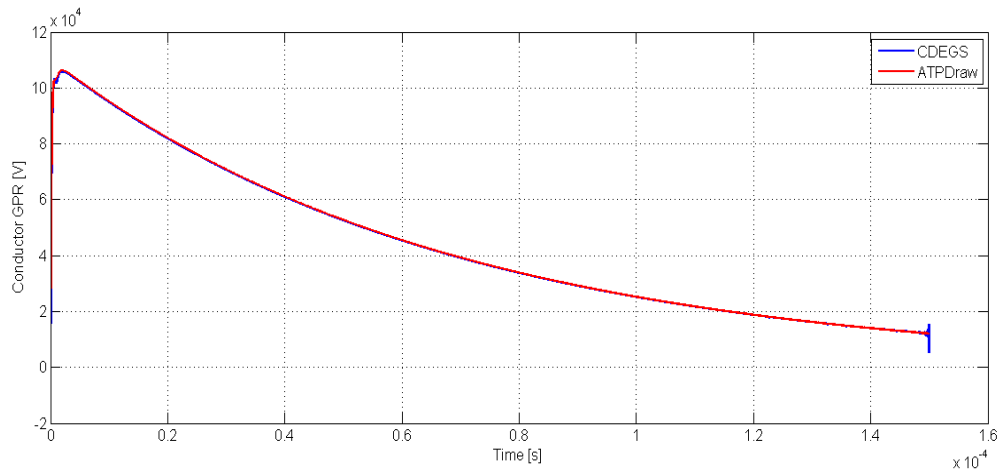
### 6.4.2. Example 1: Counterpoise Grounding

This example compares time - domain responses of a model created based on the frequency response from CDEGS simulations with relative permittivity in the soil equal to 30, and a model created by approximation of the response obtained by interpolation between relative permittivity equal to 10 and 100. Table 6.4 contains description of the case analyzed in this chapter.

**Table 6.4 Case description Example 1**

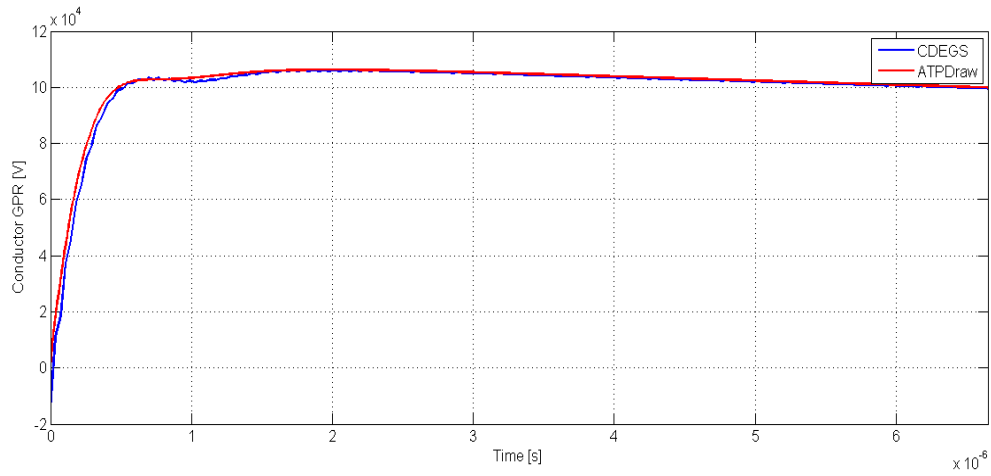
Type of electrode	Counterpoise grounding
Length	30 m (each radial)
Burial depth	0.5 m
Soil resistivity	500 Ohmm
Relative permittivity in the soil	30

Figure 6.7 and 6.8 show time response to the lightning current of the electrode described in Table 6.4. Response from ATPDraw is very similar to the response obtained in CDEGS simulations with only slight difference in the beginning.

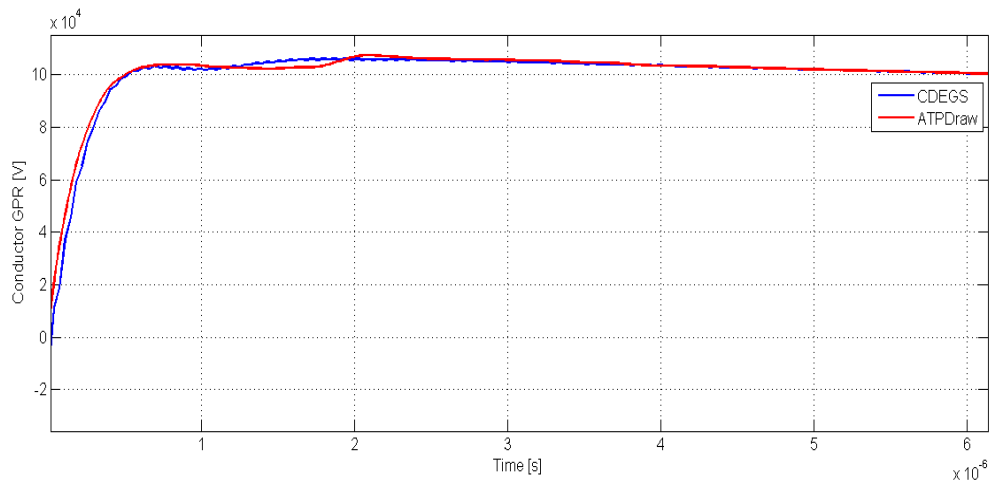


**Figure 6.7 Time domain response of a counterpoise electrode to an impulse current (radial length =30 m, burial depth = 0.5 m, soil resistivity = 500 Ohmm ,  $\epsilon_r = 30$ )**

Vector fitting in this case was performed on the frequency response of a ground electrode simulated in soil with  $\epsilon_r=30$  in CDEGS. In order to check if interpolation between 10 and 100 gives good result, vector fitting was also performed on interpolated frequency response with the help of *interfit.m*. The results appeared to be similar to the response shown in Figure 6.7. As can be seen from Figure 6.8 and 6.9 the red curve, representing response from ATPDraw, is only slightly different in the time interval between 1 and 2  $\mu$ s for actual and interpolated responses.



**Figure 6.8 Magnified curves of the time domain response of a counterpoise electrode to an impulse current (radial length =30 m, burial depth = 0.5 m, soil resistivity = 500 Ohmm ,  $\epsilon_r = 30$ )**



**Figure 6.9 Magnified curves of the time domain response of a counterpoise electrode to an impulse current (radial length =30 m, burial depth = 0.5 m, soil resistivity = 500 Ohmm ,  $\epsilon_r = 30$  (interpolated))**

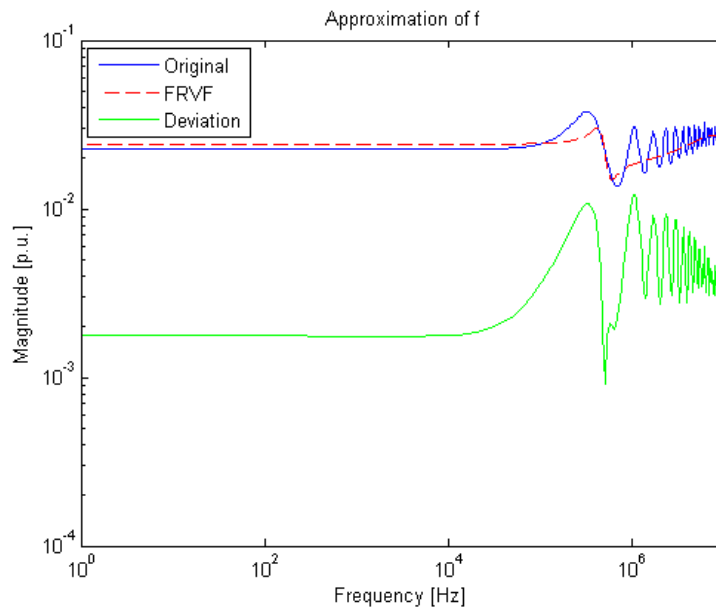
### 6.4.3. Example 2: Counterpoise Grounding

This example presents a case where order of approximation in vector fitting, denoted as  $N$  hereafter, had to be set substantially higher than 5, which was the value suggested to use in vector fitting for all cases at first. The electrode in this case has very large extension and is placed in the soil with relatively high resistivity. The description of the electrode is given in Table 6.5.

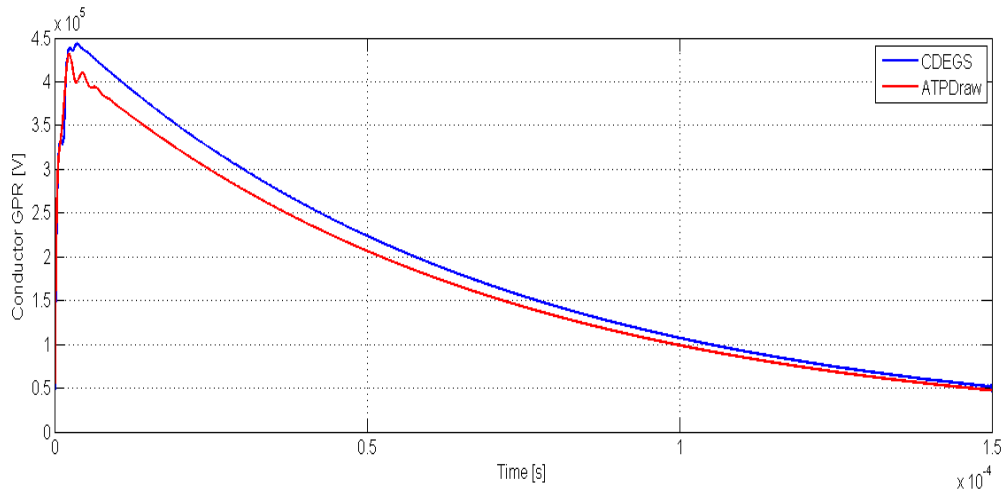
**Table 6.5 Case description Example 2**

Type of electrode	Counterpoise grounding
Length	80 m (each radial)
Burial depth	0.5 m
Soil resistivity	5000 Ohmm
Relative permittivity in the soil	10

Results of the vector fitting with order of approximation equal to 5 are shown in Figure 6.10. The response in this case has many oscillations in the high - frequency region. Results from time-domain simulations in ATPDraw and CDEGS are illustrated in Figure 6.11. It is obvious that for cases with oscillatory behaviour order of approximation should be higher.

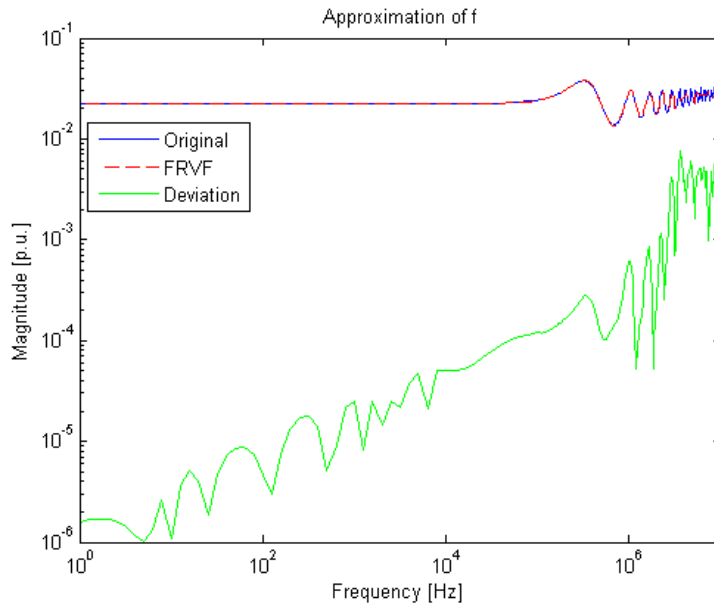


**Figure 6.10 Original and approximated ( $N=5$ ) admittance of a counterpoise electrode (radial length =80 m, burial depth = 0.5 m, soil resistivity = 5000 Ohmm ,  $\epsilon_r = 10$ )**

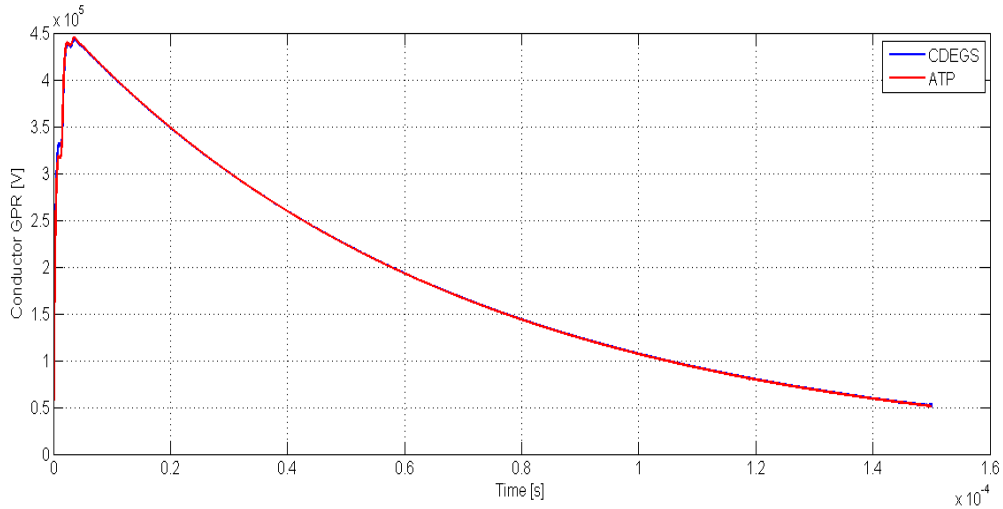


**Figure 6.11 Time domain response of a counterpoise electrode to an impulse current (radial length =80 m, burial depth = 0.5 m, soil resistivity = 5000 Ohmm ,  $\epsilon_r = 10$ , N=5)**

As can be seen from Figure 6.12 the results of vector fitting are evidently better when the order of approximation is set to 40. Response of the electrode to the lightning current is similar in CDEGS and ATPDraw as illustrated in Figure 6.13 and 6.14.

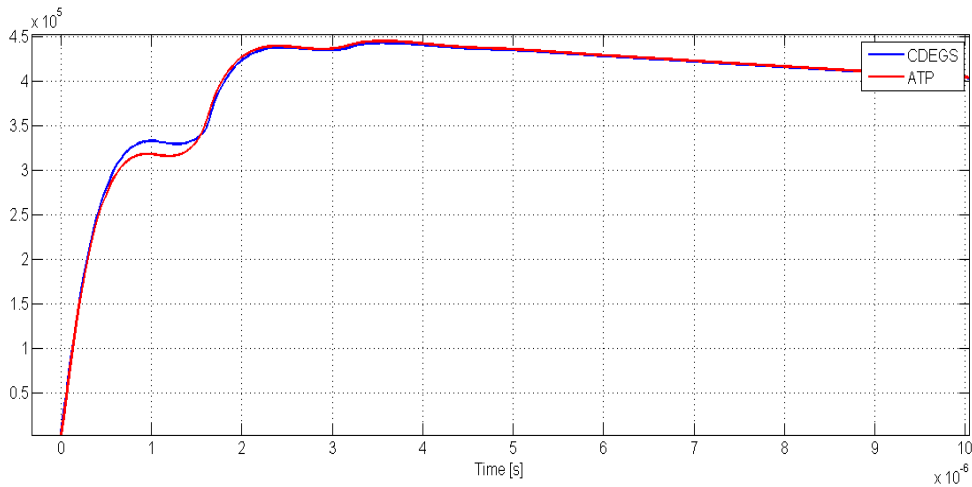


**Figure 6.12 Original and approximated (N=40) admittance of a counterpoise electrode (radial length =80 m, burial depth = 0.5 m, soil resistivity = 5000 Ohmm ,  $\epsilon_r = 10$ )**



**Figure 6.13 Time domain response of a counterpoise electrode to an impulse current (radial length =80 m, burial depth = 0.5 m, soil resistivity = 5000 Ohmm ,  $\epsilon_r = 10$ , N=40)**

Effect from wave reflections can be seen in the form of the curve between 0.5 and 4  $\mu$ s. When voltage and current waves reach a point of discontinuity (end of the ground electrode) a part of the forward-moving wave is reflected back and a part will be transmitted through the point of discontinuity [3].



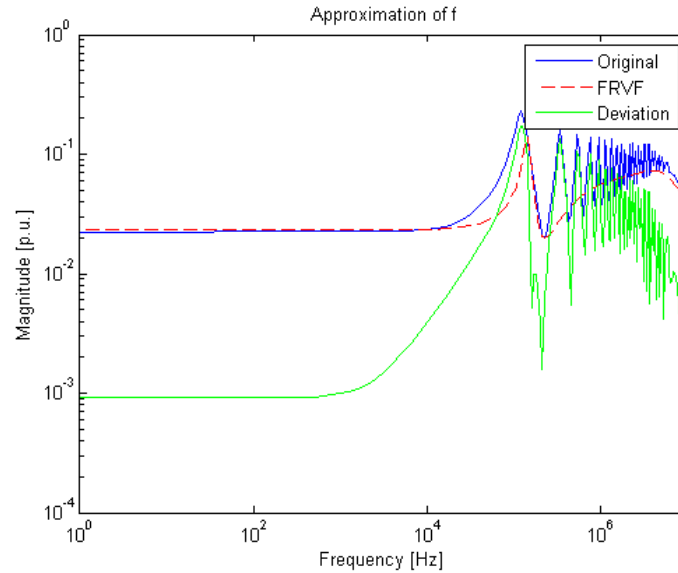
**Figure 6.14 Magnified curves of the time domain response of a counterpoise electrode to an impulse current (radial length =80 m, burial depth = 0.5 m, soil resistivity = 5000 Ohmm ,  $\epsilon_r = 10$ , N=40)**

#### 6.4.4. Example 3: Counterpoise Grounding

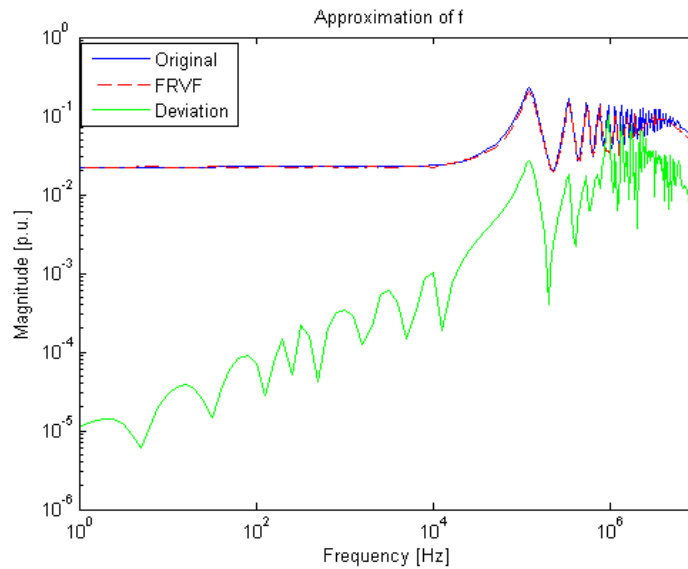
A case similar to the one in 6.4.3 is analyzed in this chapter. The only difference is in relative permittivity, which is equal to 100 in this case. In this example negative values of the resistance were present in the frequency - domain response. Based on Figure 6.15 and 6.16, 40 is an order of approximation more suitable for this response.

**Table 6.6 Case description Example 3**

Type of electrode	Counterpoise grounding
Length	80 m (each radial)
Burial depth	0.5 m
Soil resistivity	5000 Ohmm
Relative permittivity in the soil	100



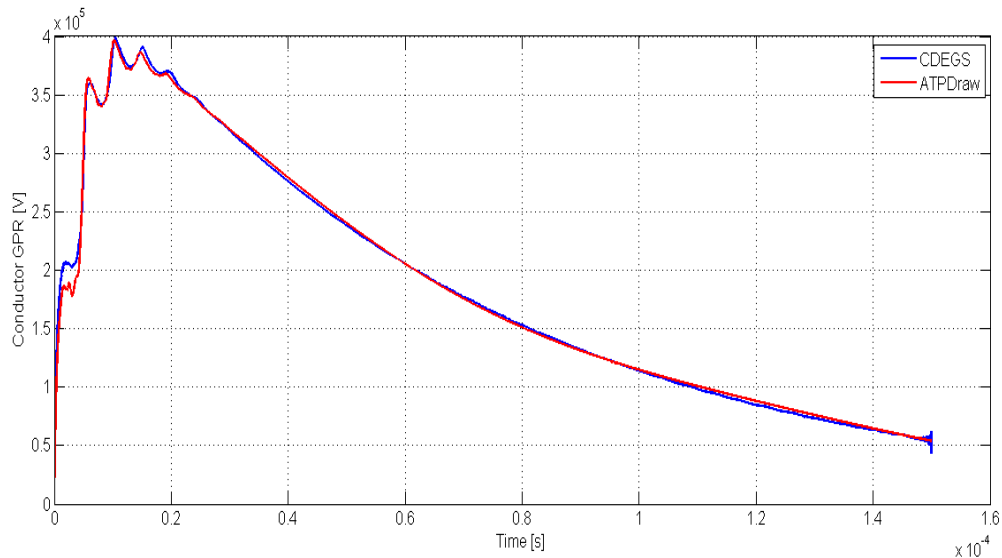
**Figure 6.15 Original and approximated (N=5) admittance of a counterpoise electrode (radial length =80 m, burial depth = 0.5 m, soil resistivity = 5000 Ohmm ,  $\epsilon_r = 100$ )**



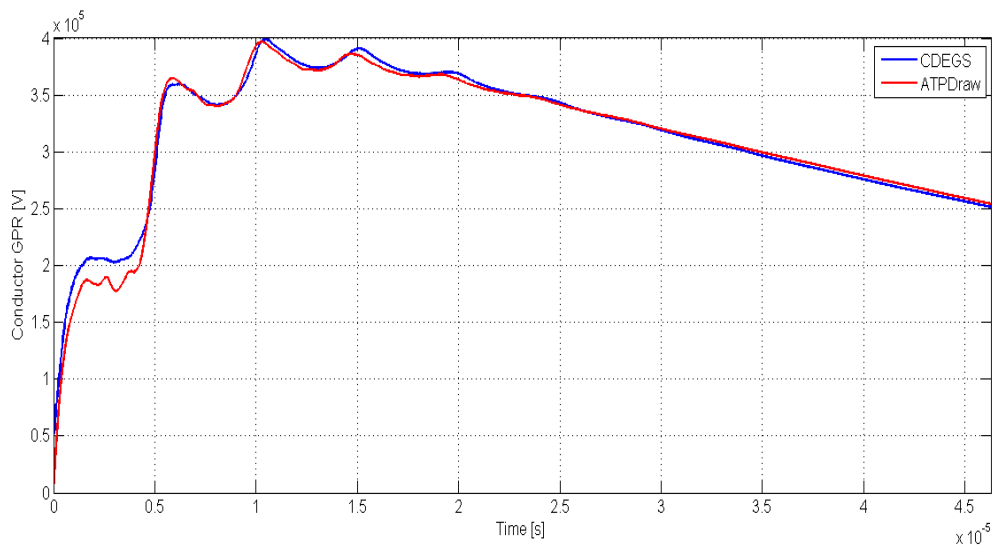
**Figure 6.16 Original and approximated (N=40) admittance of a counterpoise electrode (radial length =80 m, burial depth = 0.5 m, soil resistivity = 5000 Ohmm ,  $\epsilon_r = 100$ )**



Figure 6.17 and 6.18 illustrate time domain response to a lightning current obtained in CDEGS and ATPDraw. Compared to the response in 6.4.3 there are more fluctuations due to wave reflections in this example. The biggest difference between the responses is in the time interval from 0 to 5  $\mu\text{s}$ . Negative values in the resistance were present in the frequency response used in vector fitting. However, this has not affected the simulations in ATPDraw since the passivity of the system was enforced by RPdriver.m.



**Figure 6.17 Time domain response of a counterpoise electrode to an impulse current (radial length =80 m, burial depth = 0.5 m, soil resistivity = 5000 Ohmm ,  $\epsilon_r = 100$ , N=40)**



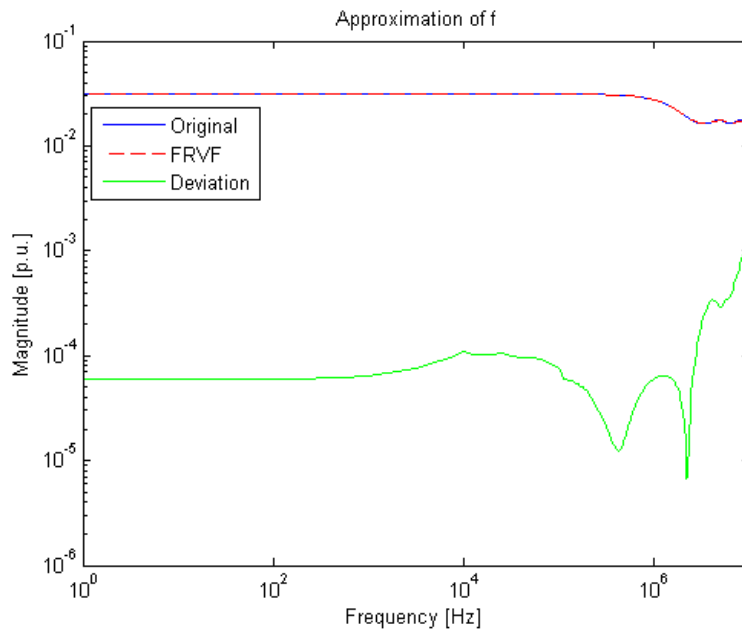
**Figure 6.18 Magnified picture of time domain response of a counterpoise electrode to an impulse current (radial length =80 m, burial depth = 0.5 m, soil resistivity = 5000 Ohmm ,  $\epsilon_r = 100$ , N=40)**

#### 6.4.5. Example 4: Horizontal Ring Electrode

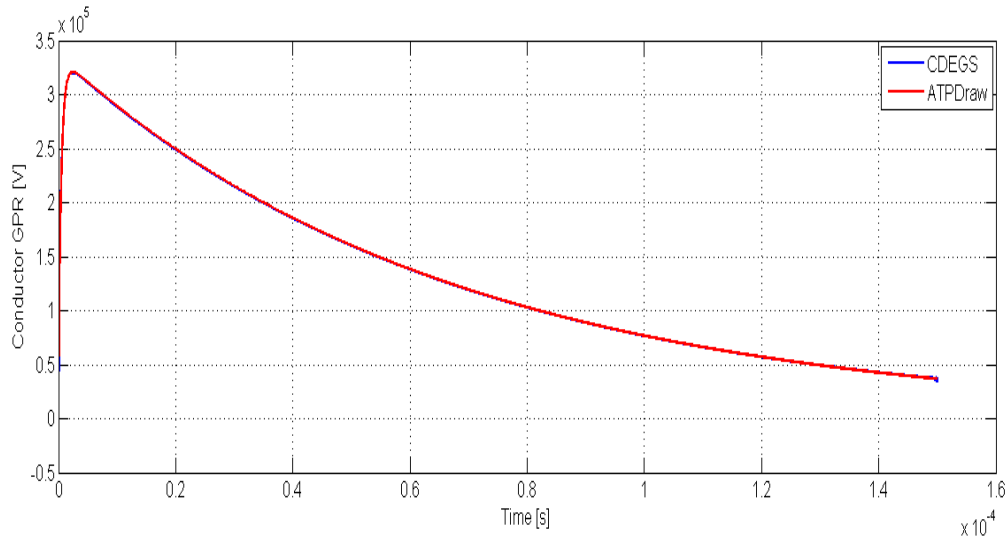
This example presents a simple ring electrode with frequency response with very few fluctuations in high-frequency region. For the configuration of a ring electrode described in Table 6.7 it was sufficient with order of approximation equal to 5 (Figure 6.19).

**Table 6.7 Case description Example 4**

Type of electrode	Ring
Radius	5 m
Burial depth	0.5 m
Soil resistivity	500 Ohmm
Relative permittivity in the soil	10

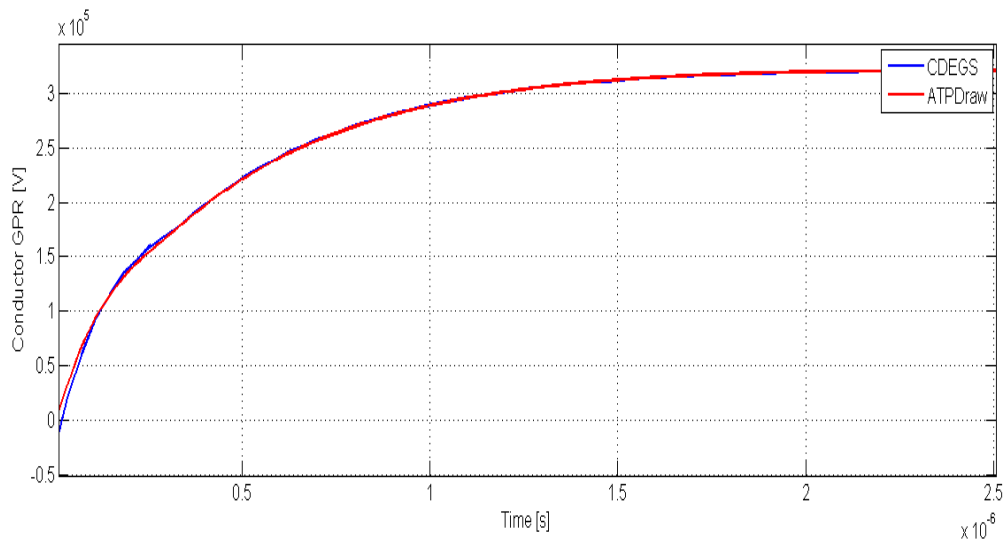


**Figure 6.19 Original and approximated (N=5) admittance of a ring electrode (radius =5 m, burial depth = 0.5 m, soil resistivity = 500 Ohmm ,  $\epsilon_r = 10$ )**



**Figure 6.20 Time domain response to an impulse current of a counterpoise electrode (radius =5 m, burial depth = 0.5 m, soil resistivity = 500 Ohmm ,  $\epsilon_r = 10$ , N=5)**

Time domain response from CDEGS and ATPDraw are very similar in this case, with only slight difference between 0 and 5  $\mu$ , as shown in Figure 6.20 and 6.21.



**Figure 6.21 Magnified curves of the time domain response to an impulse current of a counterpoise electrode (radius =5 m, burial depth = 0.5 m, soil resistivity = 500 Ohmm ,  $\epsilon_r = 10$ , N=5)**

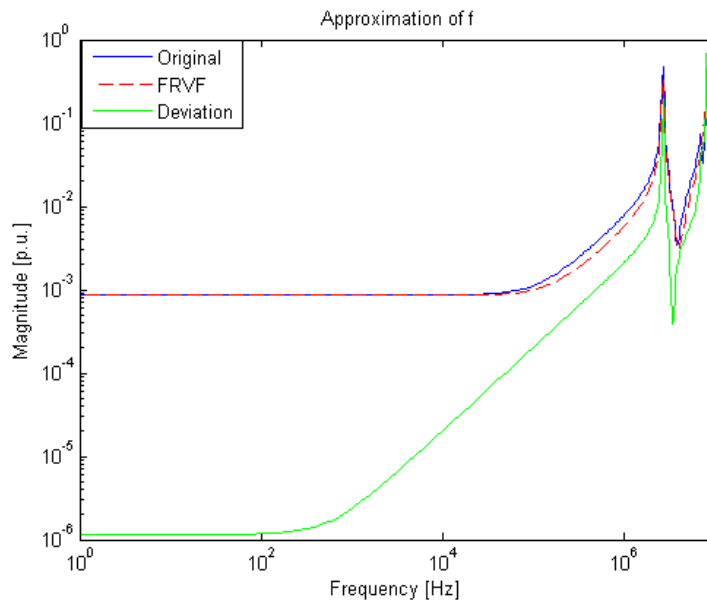
#### 6.4.6. Example 5: Horizontal Ring Electrode

This chapter describes a case in which it was necessary with adjustments in the order of approximation due to passivity enforcement. Negative values of the resistance were present in the frequency domain response from CDEGS for this configuration. Passivity of the model is enforced by perturbation of the model residues matrices.

**Table 6.8 Case description Example 5**

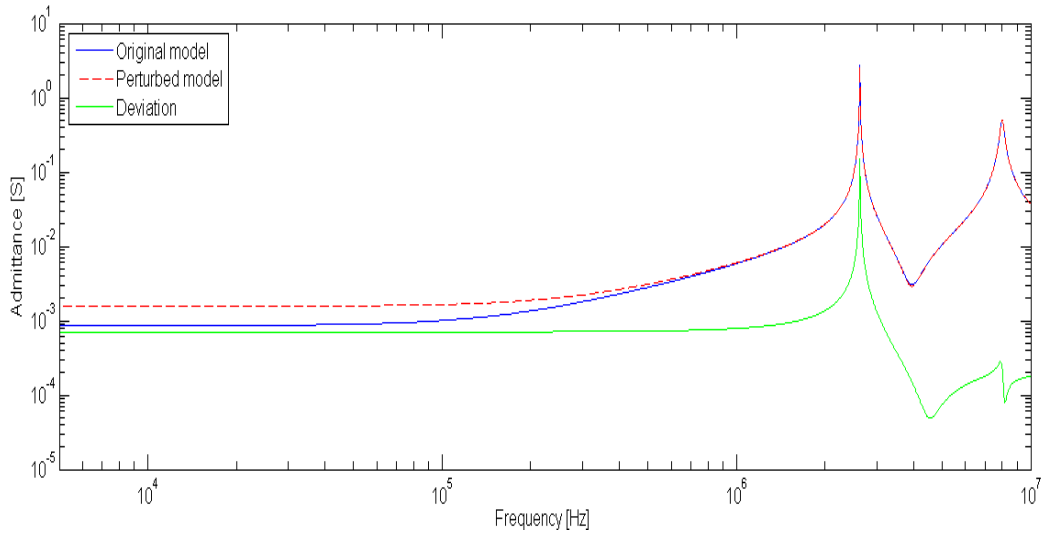
Type of electrode	Ring
Radius	1 m
Burial depth	0.5 m
Soil resistivity	5000 Ohmm
Relative permittivity in the soil	30

With the order of approximation equal to five, there is some difference between original and fitted responses (Figure 6.22).



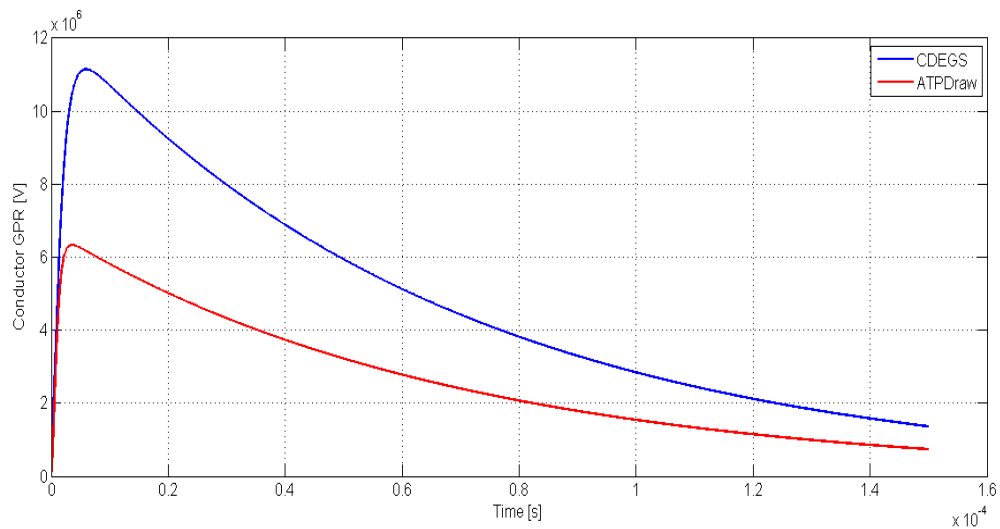
**Figure 6.22 Original and approximated (N=5) admittance of a ring electrode (radius =1 m, burial depth = 0.5 m, soil resistivity = 5000 Ohmm ,  $\epsilon_r = 30$ )**

Figure 6.23 shows the admittance after the model is created by VFdriver.m (blue line) and the model after passivity was enforced by RPdriver.m (stippled red line). There is a substantial deviation between these models in the low – frequency region.



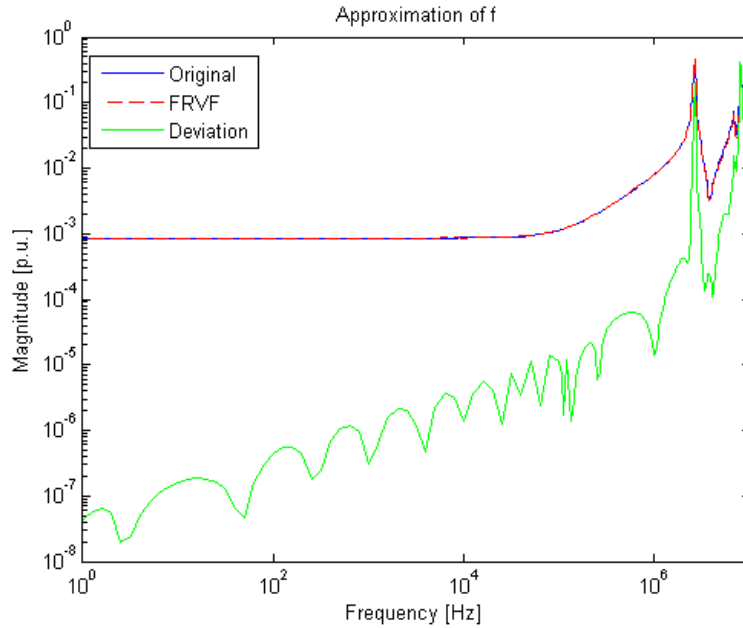
**Figure 6.23 Admittance after the passivity enforcement ( $N=5$ ) of a ring electrode (radius =1 m, burial depth = 0.5 m, soil resistivity = 5000 Ohmm ,  $\epsilon_r = 30$ )**

As can be seen from Figure 6.24, responses in CDEGS and ATPDraw to the same lightning current are similar in shape, but there is great difference in magnitude of the GPR.

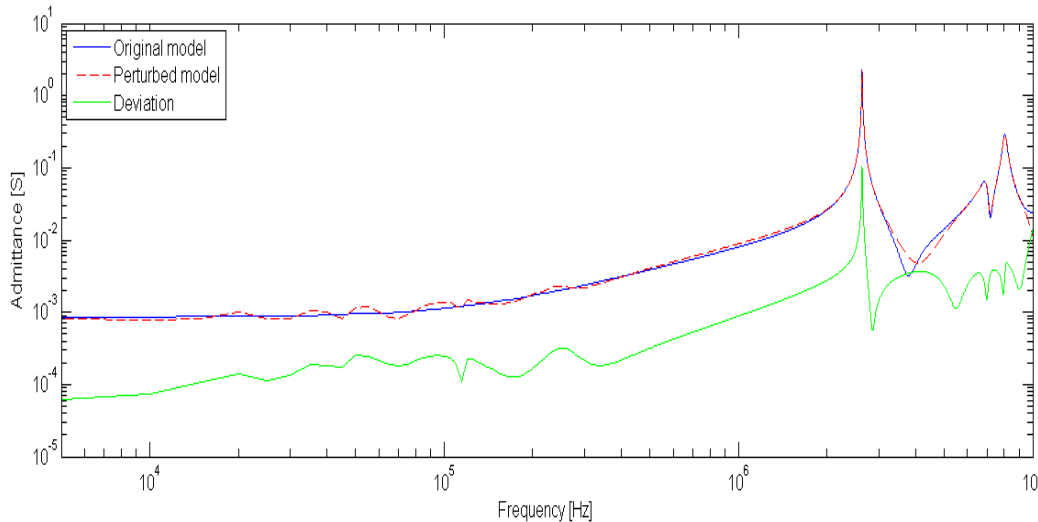


**Figure 6.24 Time domain response to an impulse current of a counterpoise electrode (radius =1 m, burial depth = 0.5 m, soil resistivity = 5000 Ohmm ,  $\epsilon_r = 30$ ,  $N=5$ )**

Choosing 40 as an order of approximation appeared to be too high, however. There is small deviation between the original and approximated responses at first (Figure 6.25), but after passivity is enforced the deviation between the responses increases (Figure 6.26).

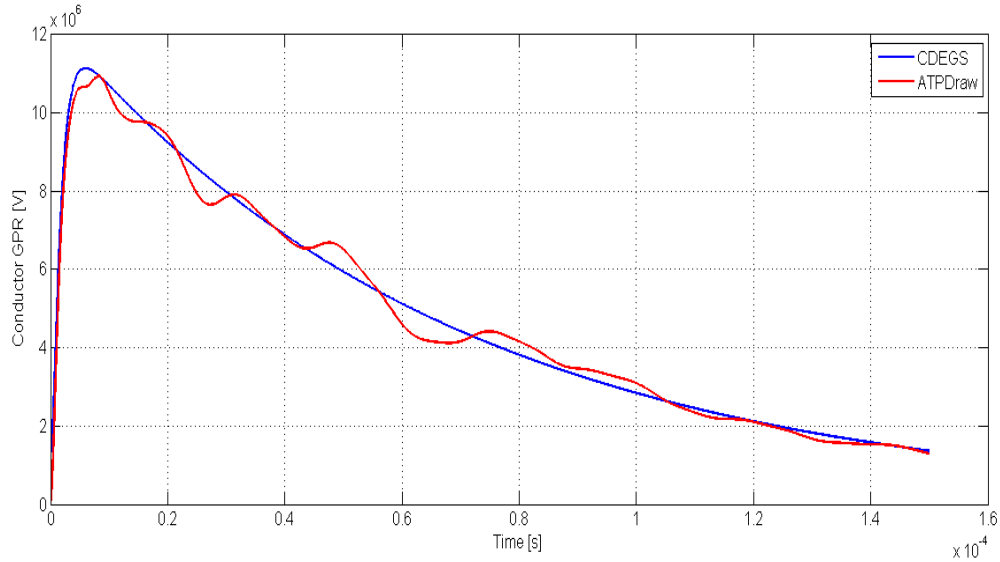


**Figure 6.25 Original and approximated (N=40) admittance of a ring electrode (radius =1 m, burial depth = 0.5 m, soil resistivity = 5000 Ohmm ,  $\epsilon_r = 30$ )**



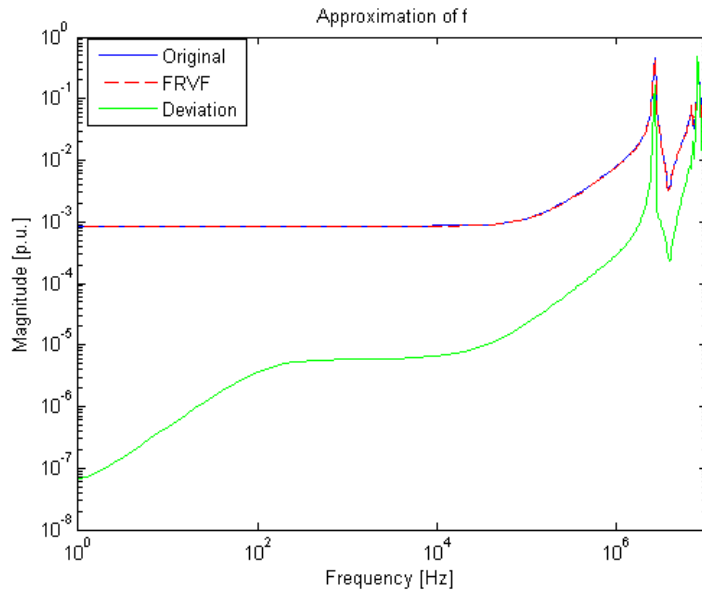
**Figure 6.26 Admittance after the passivity enforcement (N=40) of a ring electrode (radius =1 m, burial depth = 0.5 m, soil resistivity = 5000 Ohmm ,  $\epsilon_r = 30$ )**

With this high number of poles, frequency response deviates greatly from the original one after the passivity has been enforced. As can be seen from Figure 6.26 there are some fluctuations in the low frequency region. This deviation is truly the reason for the fluctuations in the time - domain response. Results in time domain match better in magnitude, but there are a lot of fluctuations in the response from ATPdraw, as can be seen from Figure 6.27.

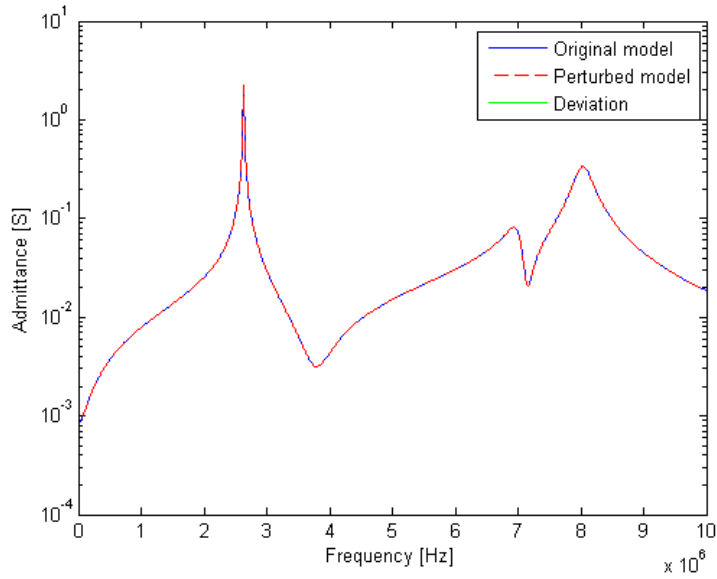


**Figure 6.27 Time domain response to an impulse current of a counterpoise electrode (radius = 1 m, burial depth = 0.5 m, soil resistivity = 5000 Ohmm ,  $\epsilon_r = 30$ , N=40)**

Frequency response of this electrode has only few oscillations in the high frequency region, compared to the examples above. It is reasonable to assume that that order of approximation can be sufficiently lower than 40. Ten appeared to be a number that gave sufficient approximation to the original response from CDEGS as illustrated in Figure 6.28 and 6.29.

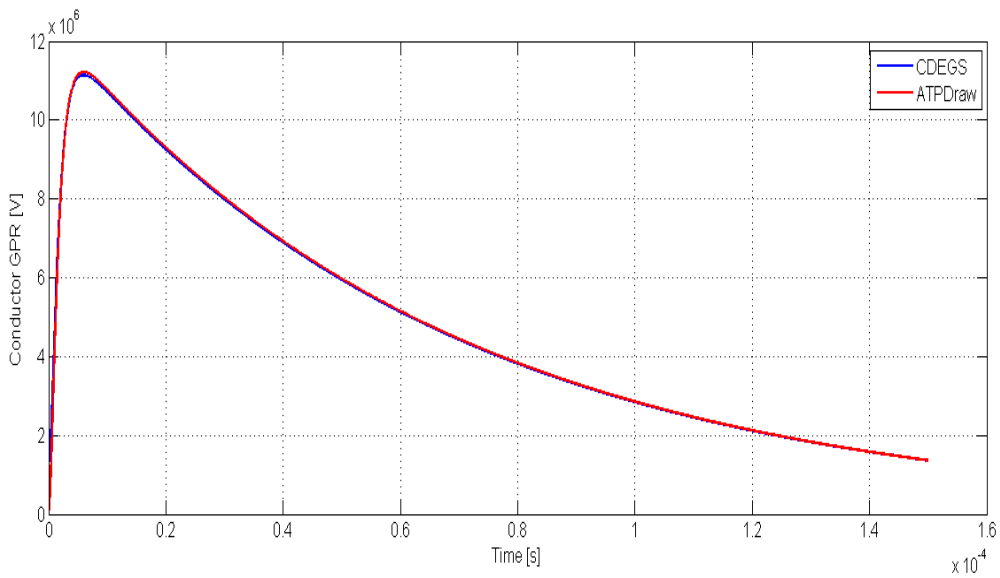


**Figure 6.28 Original and approximated (N=10) admittance of a ring electrode (radius = 1 m, burial depth = 0.5 m, soil resistivity = 5000 Ohmm ,  $\epsilon_r = 30$ )**



**Figure 6.29 Admittance after the passivity enforcement ( $N=10$ ) of a ring electrode (radius = 1 m, burial depth = 0.5 m, soil resistivity = 5000 Ohmm ,  $\epsilon_r = 30$ )**

In this case time domain responses were very similar in CDEGS and in ATPDraw as shown in Figure 6.30.



**Figure 6.30 Time domain response to an impulse current of a counterpoise electrode (radius = 1 m, burial depth = 0.5 m, soil resistivity = 5000 Ohmm ,  $\epsilon_r = 30$ ,  $N=10$ )**

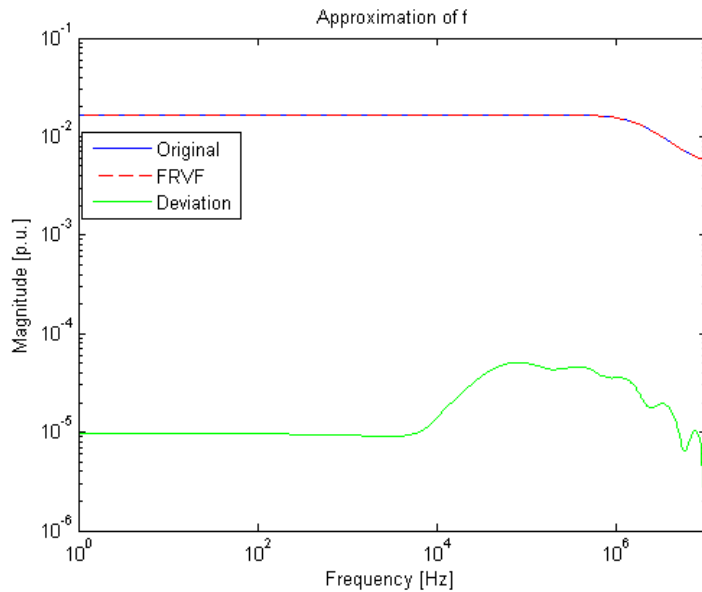


### 6.4.7. Example 6: Earthing Rod

In this example a response with no oscillations in high frequency region is analyzed. Parameters of the earthing rod described in this chapter are listed in Table 6.9.

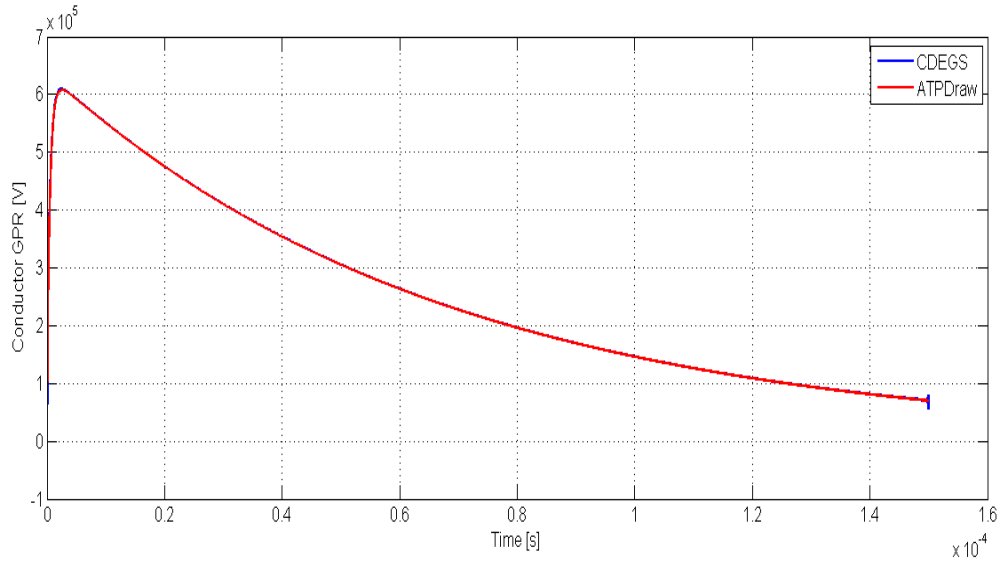
**Table 6.9 Case description Example 6**

Type of electrode	Earthing rod
Length	10 m
Soil resistivity	500 Ohmm
Relative permittivity in the soil	1

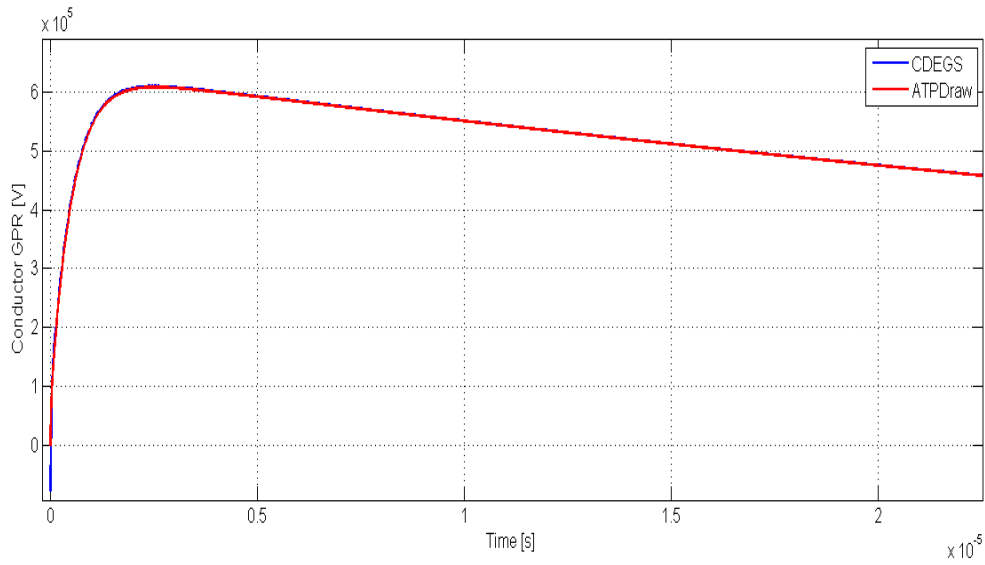


**Figure 6.31 Original and approximated (N=5) admittance of an earthing rod (length =10 m, soil resistivity = 500 Ohmm ,  $\epsilon_r = 1$ )**

In this case it was sufficient to use five as the order of approximation in vector fitting, that is confirmed by Figure 6.31. Time-domain simulations gave similar results in CDEGS and ATPDraw as can be seen from Figure 6.32 and 6.33.



**Figure 6.32 Time domain response to an impulse current of an earthing rod (length =10 m, soil resistivity = 500 Ohmm ,  $\epsilon_r = 1$ , N=5)**

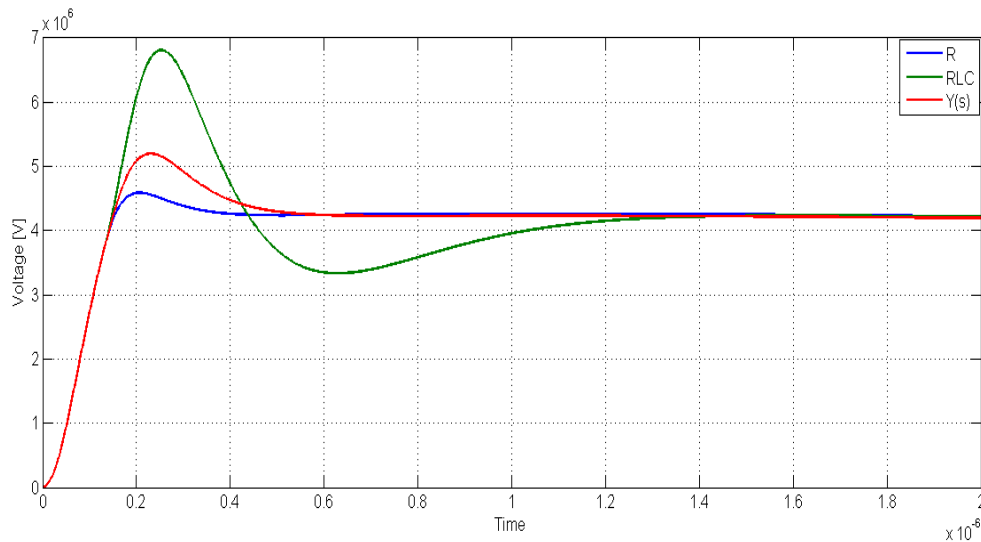


**Figure 6.33 Magnified picture of time domain response to an impulse current of an earthing rod (length =10 m, soil resistivity = 500 Ohmm ,  $\epsilon_r = 1$ , N=5)**

## 6.5. Comparison of Different Grounding Models

Tower-foot grounding is usually modelled as a pure resistance. Such approach does not give completely correct result when analysing electrode's response to high-frequent impulse current. Grounding can also be modelled as a lumped circuit as described in 2.4. In this report another method for modelling of ground electrode is introduced. Admittance of the system as a function of frequency is approximated as a rational function by vector fitting. This pole-residue model can be used to create an equivalent circuit for ATP.

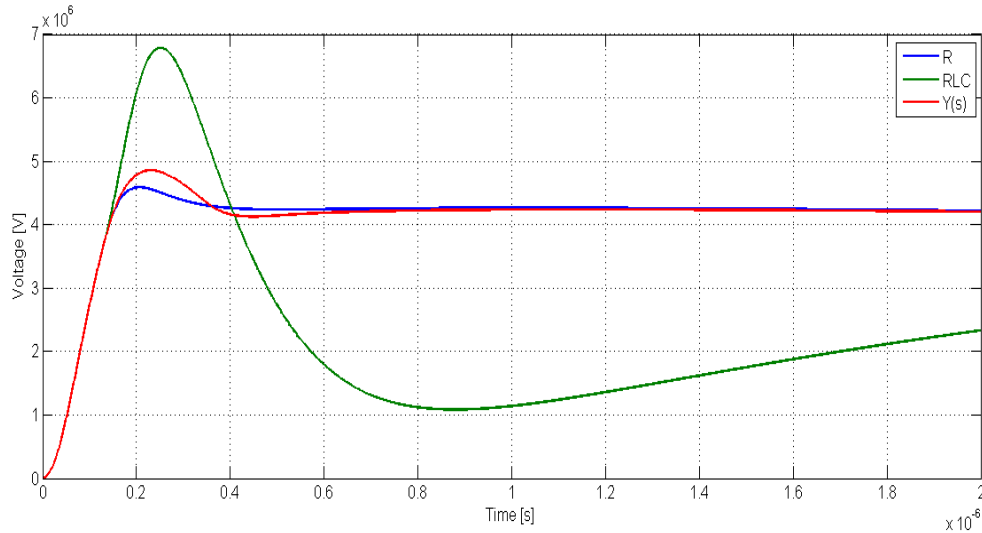
Using Eq.6 and Eq. 10, 11 and 12 equivalent components of grounding model were calculated for an earthing rod with the dimensions described in 6.4.7. In addition a grounding model using *netgen\_ATP.m* was created. These three models were connected to a transmission tower with overhead ground wire in ATPDraw. Lightning strike at the top of the tower was simulated. Time-domain response to an impulse current with peak value of 100 kA is presented in Figure 6.34. R denotes that the curve is a response of the model consisting of pure resistance calculated with the help of Eq.6, RLC means that the curve is a response of the model consisting of resistance, inductance and capacitance (Eq.10, 11 and 12), and Y(s) stands for the model obtained by rational function approximation of the frequency - domain response of the electrode.



**Figure 6.34 Time domain response for three different models of an earthing rod in ATPDraw (length = 10 m, soil resistivity = 500 Ohmm,  $\epsilon_r = 1$ )**

As evident from Figure 6.34 frequency dependent electrode model (red curve) gives higher voltage peak than the pure resistive model. A model consisting of R, L and C gives very high voltage peak. These responses are for electrode in the soil with relative permittivity equal to one. While capacitance in a lumped model is proportional to relative permittivity, pure resistive model is independent of this parameter. When relative permittivity is changed to 10 the blue

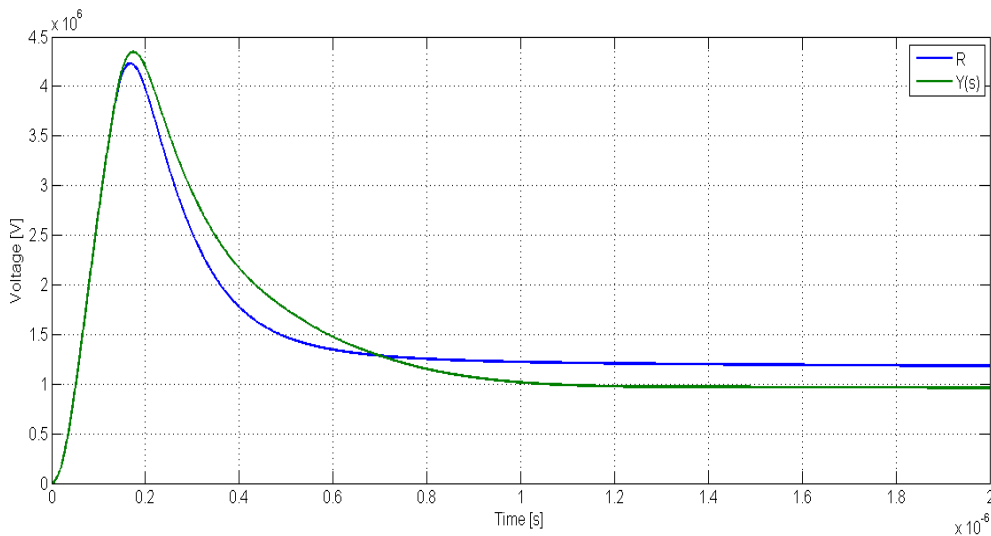
curve remains the same, while there are evident changes in the responses from two other models as shown in Figure 6.35.



**Figure 6.35 Time domain response for three different models of an earthing rod in ATPDraw (length = 10 m, soil resistivity = 500 Ohmm,  $\epsilon_r = 10$ )**

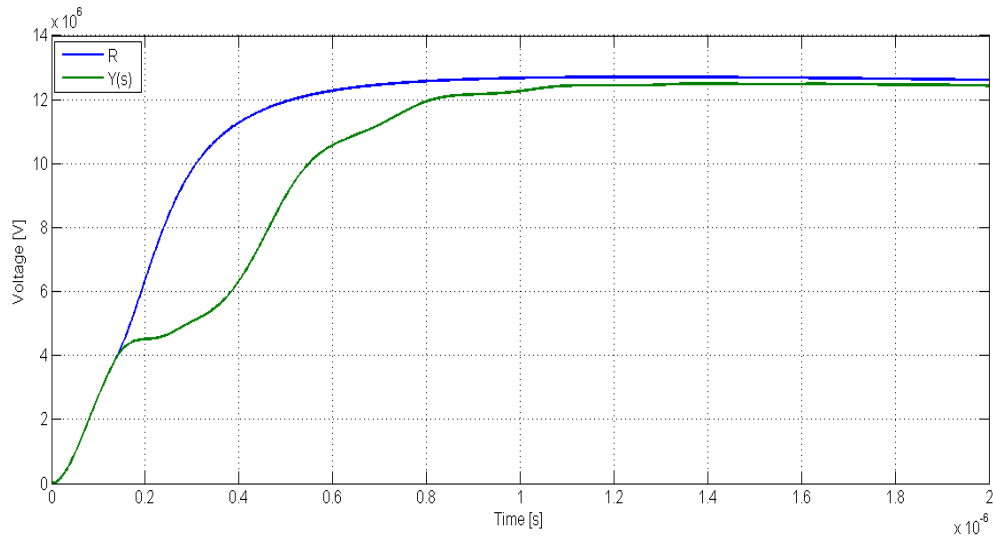
No lumped - parameter equivalent circuit was calculated for counterpoise and ring electrodes. Pure resistive models were calculated using Eq.7 and 9 respectively.

Figure 6.36 presents time domain response of a counterpoise ground electrode described in 6.4.2. Voltage peak is higher for frequency - dependent model here as well.



**Figure 6.36 Time domain response for two different models of a counterpoise electrode in ATPDraw (radial length = 30 m, burial depth = 0.5 m, soil resistivity = 500 Ohmm,  $\epsilon_r = 30$ )**

Same results for a ring electrode described in 6.4.6 are presented in Figure 6.37. For a ring electrode with these dimensions the voltage is actually lower than in case with the pure resistive model.



**Figure 6.37 Time domain response for two different models of a ring electrode in ATPDraw (radius = 1 m, burial depth = 0.5 m, soil resistivity = 5000 Ohmm,  $\epsilon_r = 30$ )**

## 6.6. Discussion

A Matlab function *interp* used for interpolation does not extrapolate; this creates constraints for which value the response can be obtained. A solution to this problem could be to include an extreme point for each parameter (for example 500 m long radial for counterpoise grounding). For soil resistivity maximum value was set to 50 000 Ohmm, which is the maximum value listed in European Standard EN 50341-1. Maximum value of relative permittivity was set to 100 which was assumed to be high enough. Choice of the values for geometrical dimensions was based on general recommendations given by Statnett for tower-foot grounding in Norway. For simulations at high frequency segment length in CDEGS should be very short. For extremely long conductor, for example 500 m, required number of conductors will be at least 500. In this case simulation time will be extremely long. Simulation with low number of segments will not give reliable results, and due to this fact extreme point was not included in parameters for geometrical dimensions.

All conductors were modelled as bare copper conductors, thus, in addition to the extension of the horizontal electrodes geometry, length of the conductor used to lead the current to the electrode dissipates current into the soil as well. It results in 0.5 or 1 m of copper conductor extra for counterpoise and ring electrodes depending on burial depth.

Comparison of the results from CDEGS and ATPDraw simulation suggest that vector fitting gives good approximation for such frequency responses if the order of approximation is chosen correctly. This fact confirms that it is most suitable to store the original frequency response in the database, not pole-residue models. The order of approximation should be changed manually in the function source code. It should neither be too low nor too high since it appeared that high number of poles can lead to substantial deviation from the original model after passivity enforcement in some cases. This fact suggests that the order of approximation should be raised gradually and the one giving sufficient approximation after passivity enforcement should be chosen.

Results from the simulations suggest that number of oscillations increases with relative permittivity and resistivity of the soil. They also indicate that number of oscillations is dependent on the electrode extension, increase in geometrical dimensions led to increased number of oscillations in high frequency region in the cases analysed. Based on this, a general guideline for the choice of order of approximation is that for higher values of model's parameters order of approximation in vector fitting should be higher as well.

Frequency-dependent model of a ground electrode showed better accuracy in response to lightning current when compared to grounding modelled as pure resistance. Voltage rise was substantially higher in many cases.

## 7. Conclusion

As a result of the project a database containing impedance and admittance as function of frequency for three electrode types has been created. Total number of responses stored in the database is 2268. A Matlab routine `interfit.m` was developed to extract response of an electrode with given parameters. For parameters between the points in the database, linear interpolation is used. Extrapolation is not possible with the help of this routine. For cases when one or several parameters exceed the limits, a corresponding message appears, no frequency response is constructed in this case. New values that are within the limits should be passed to the function.

The Matlab source codes can easily be altered in case one wishes to expand the database or construct a new one. Other dimensions and electrode types can be added.

Frequency resolution for the simulations should be at least 80 points per decade between 1 MHz and 10 MHz. Less points can be used for lower frequencies.

Linear interpolation between original frequency responses is a suitable method for these cases. Storage of the original response data instead of pole –residue models appears to be the best solution also because order of approximation in vector fitting should be adjusted for each case.

One should start with a low order of approximation, and increase it gradually till a sufficient approximation after passivity enforcement is achieved. It is not possible to set it to a value that is high enough for all cases since too many poles can lead to substantial deviation from the original response after passivity enforcement for some configurations.

Time – domain simulations in CDEGS and ATPDraw gave similar results when order of approximation in vector fitting was chosen correctly. Negligible deviation was observed between the responses in time range between 0 and 5  $\mu$ s. The results indicate that frequency - dependent models created by this method can be used in EMTP programs.

## 8. Future Work

In future other electrode types can be added to the database, for example counterpoise grounding combined with earthing rods or counterpoise grounding with three radials.

CDEGS simulations are time requiring and it was considered when the number of parameters was determined in the project. Therefore, resolution for some parameters can be increased.

A solution which allows extrapolation can also be considered in the future work.

It might be interesting to include cross-sectional area as parameter for better accuracy of the results. Two-layered soil model can also be used in the simulations.

In some cases the response from CDEGS did not give a full physical picture since only ground electrode was modelled. It is therefore interesting to consider modelling an entire system which includes current return path.



## References

- [1] Kiessling F., Nefzger P., Nolasco J.F., Kaintzyk U., "Overhead Power Lines: Planning, Design, Construction", Springer, 2003
- [2] European Standard EN 50341-1, "Overhead Electrical Lines Exceeding 45 kV", CENELEC, 2001
- [3] Chowdhuri P., "Electromagnetic Transients in Power Systems", Research Studies press Ltd., 2<sup>nd</sup> edition, 2004
- [4] Seljeseth H., Jordingshåndbok for elkraftanlegg, Energiforsyningens Forskningsinstitutt AS, Mai 1996
- [5] RENBLAD nr. 8010, "Distribusjonsnett-Jordingssystem-Prosjektering", Rasjonell elektrisk nettvirksomhet, versjon 3.4, 2012
- [6] RENBLAD nr. 8011, "Distribusjonsnett- Jordingsystem og overspenningsvern- Montasje", Rasjonell elektrisk virksomhet, versjon 3.2, 2012
- [7] Earthing specification, Statnett SF, rev. 9, 2011
- [8] Brede A.P., Høidalen H.K., Pleym A., Rørvik O., Seljeseth H., "Underlag for beregninger og målinger på jordelektroder i forskjellige elkraftanlegg", rapport EFI SINTEF gruppen, 1995
- [9] Instruks for jordingsmåling. Planlegging og kontrollmåling, Statnett, 2005
- [10] Martinez – Velasco J.A., "Power System Transients: Parameter Determination", CRC Press, 2010
- [11] He J., Gao Y., Zeng R., Zou J., Liang X., Zhang B., Lee J., Chang S., "Effective Length of Counterpoise Wire under Lightning Current", IEEE Transactions on Power Delivery, Vol.20, no. 2, April 2005
- [12] Høidalen H.K., "TET 4130 Overspenninger og overspenningsvern", NTNU, 2007
- [13] He J., Zeng R., Tu Y., Zou J., Chen S., Guan Z., " Laboratory Investigation of Impulse Characteristics of Transmission Tower Grounding devices", IEEE Transactions on Power Delivery, Vol.18, No.3, July 2003
- [14] Nor N.M., Ramli A., "Soil Characteristics of Wet Sand under Different Impulse Polarity and earth Electrode's Dimensions", IEEE Transactions on Dielectrics and Electrical Insulation, Vol.15, No.4, August 2008
- [15] Haddad A., Griffiths H., Ahmeda M., Harid N., "Experimental Investigation of the Impulse Characteristics of Practical Ground Electrode Systems", International Conference on High Voltage Engineering and Application, pp. 469 – 472, 2010

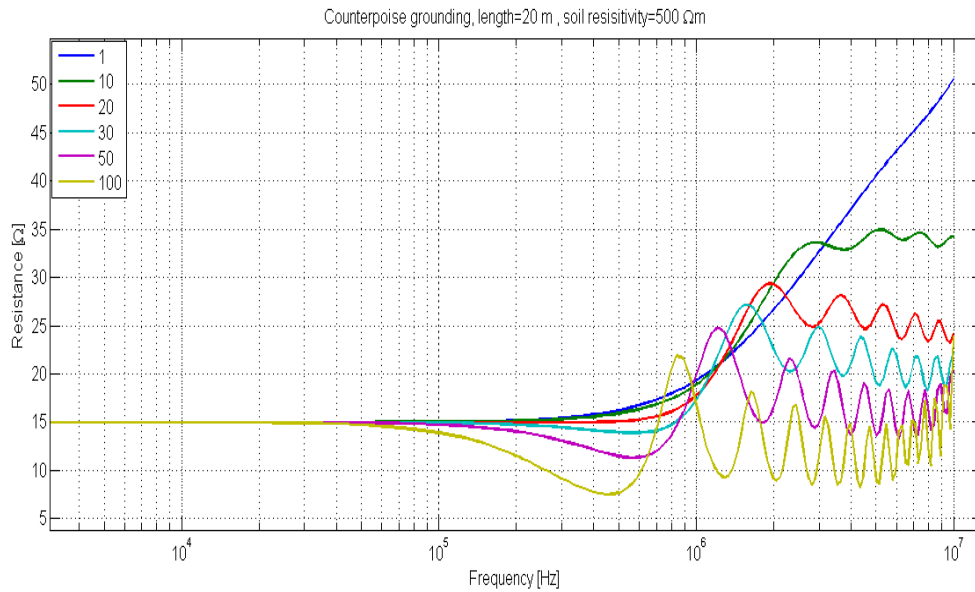
- [16] Grcev L., "Impulse Efficiency of Ground Electrodes", IEEE Transactions on Power Delivery, Vol. 24, No. 1, January 2009
- [17] He J., Chen X., Huang Y., Zhang J., " Impulse Characteristics of Grounding Systems of Transmission Line Towers", IEEE TENCON, 1993
- [18] <http://www.sestech.com/Products/SoftPackages/CDEGS.htm>
- [19] <http://www.sestech.com/Products/SoftUtil/SESCAD.htm>
- [20] Gustavsen B., Semlyen A., "Rational Approximation of Frequency Domain Responses by Vector Fitting", IEEE Trans. Power Delivery, vol.21, no. 3, pp. 1052 – 1061, July 1999
- [21] D. Deschrijver, M. Mrozowski, T. Dhaene, and D. De Zutter, "Macromodeling of Multiport Systems Using a Fast Implementation of the Vector Fitting Method", IEEE Microwave and Wireless Components Letters, vol. 18, no. 6, pp. 383-385, June 2008. Link
- [22] Gustavsen B., "Improving the Pole Relocating Properties of Vector Fitting", IEEE Trans. Power Delivery, vol.21, no.3, pp. 1587 – 1592, July 2006
- [23] Gustavsen B., "Fast Passivity Enforcement for Pole – Residue Models by Perturbation of Residue Matrix Eigenvalues", IEEE Transactions on Power Delivery, vol. 23, no. 4, October 2008
- [24] A. Semlyen and B. Gustavsen, "A half-size singularity test matrix for fast and reliable passivity assessment of rational models", IEEE Trans. Power Delivery, vol. 24, no. 1, pp. 345-351, January 2009.
- [25] B. Gustavsen and A. Semlyen, "Fast passivity assessment for S-parameter rational models via a half-size test matrix", IEEE Trans. Microwave Theory And Techniques, vol. 56, no. 12, pp. 2701-2708, December 2008.
- [26] B. Gustavsen, "Fast passivity enforcement for S-parameter models by perturbation of residue matrix eigenvalues", IEEE Trans. Advanced Packaging, accepted. Available online: <http://ieeexplore.ieee.org>
- [27] <http://www.sintef.no/Projectweb/VECTFIT/Downloads/Matrix-Fitting-Toolbox/>
- [28] Gustavsen B., "Matrix Fitting Toolbox: User's guide and reference", SINTEF Energy Research, 2009

## Appendix A

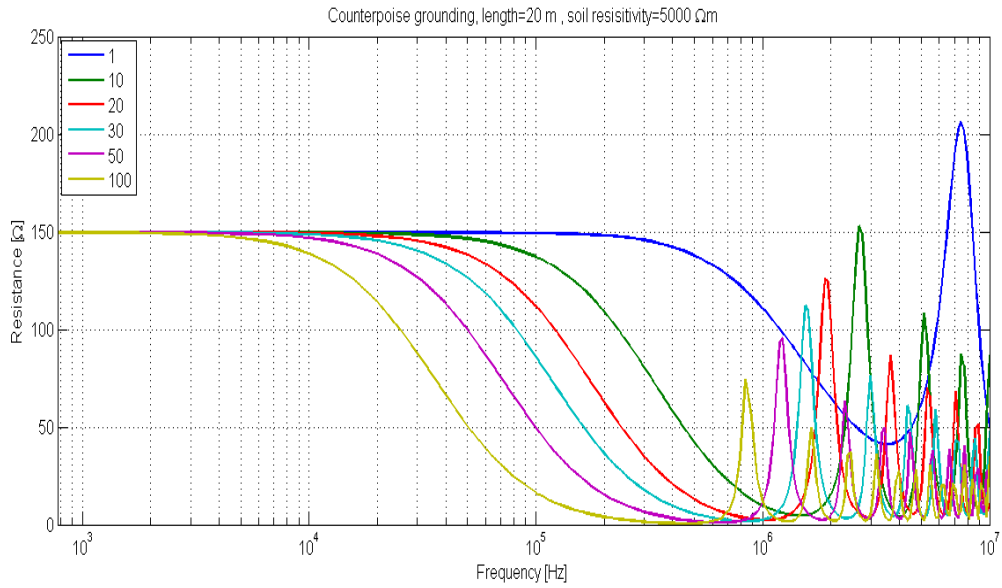
### Influence from relative permittivity on resistance to earth of an earthing rod and counterpoise grounding

#### 1. Counterpoise grounding

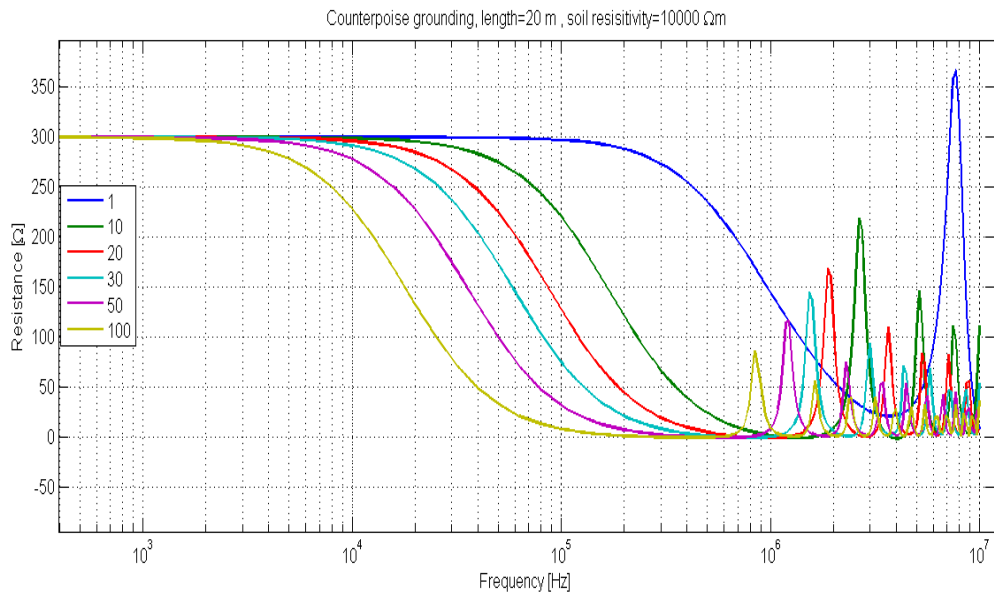
- 1) Counterpoise grounding with four 20 metres long radials in soil with resistivity of 500 Ohmm and different relative permittivity



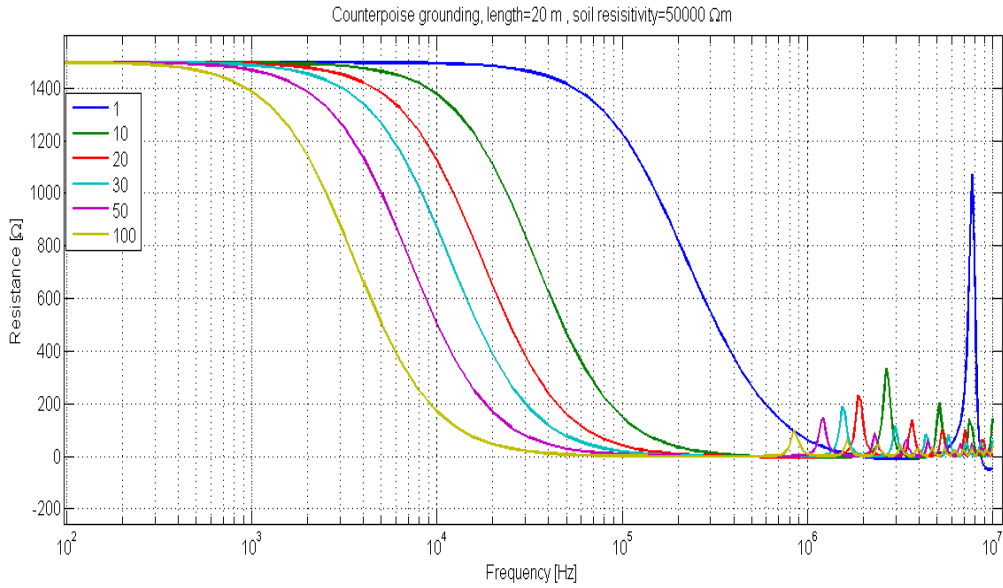
- 2) Counterpoise grounding with four 20 metres long radials in soil with resistivity of 5000 Ohmm and different relative permittivity



- 3) Counterpoise grounding with four 20 metres long radials in soil with resistivity of 10000 Ohmm and different relative permittivity

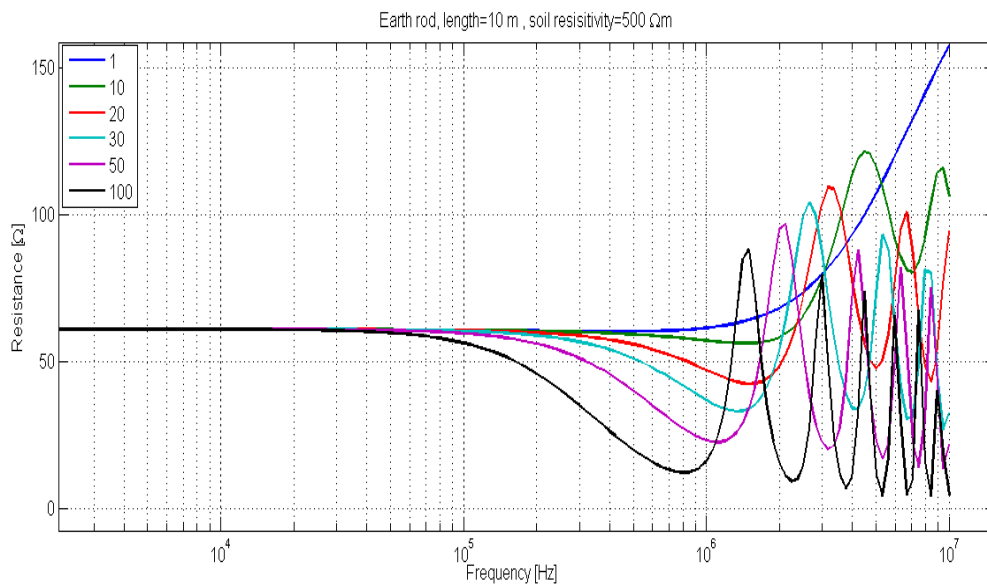


- 4) Counterpoise grounding with four 20 metres long radials in soil with resistivity of 50000 Ohmm and different relative permittivity

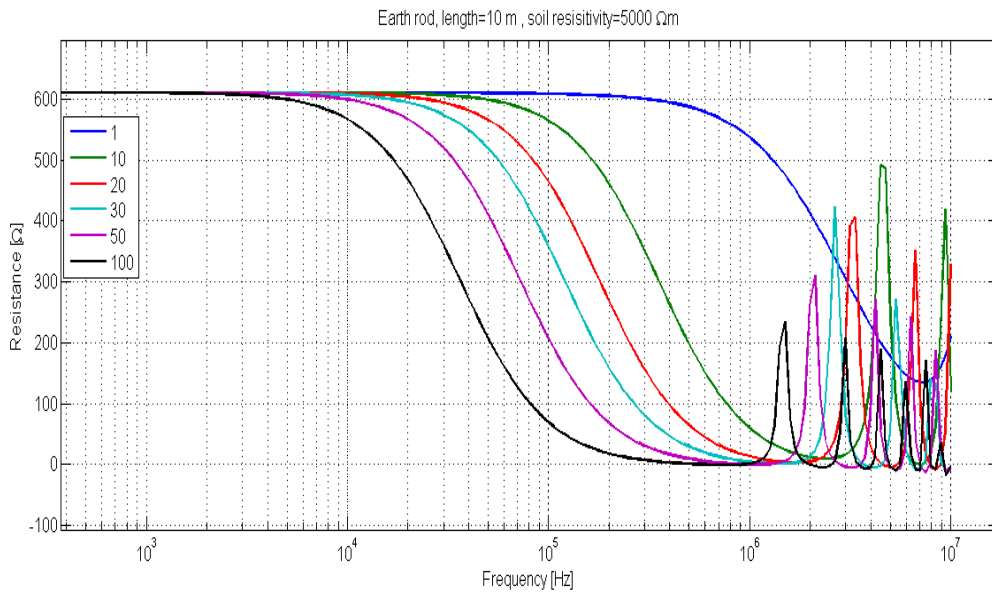


**2. Earthing rod**

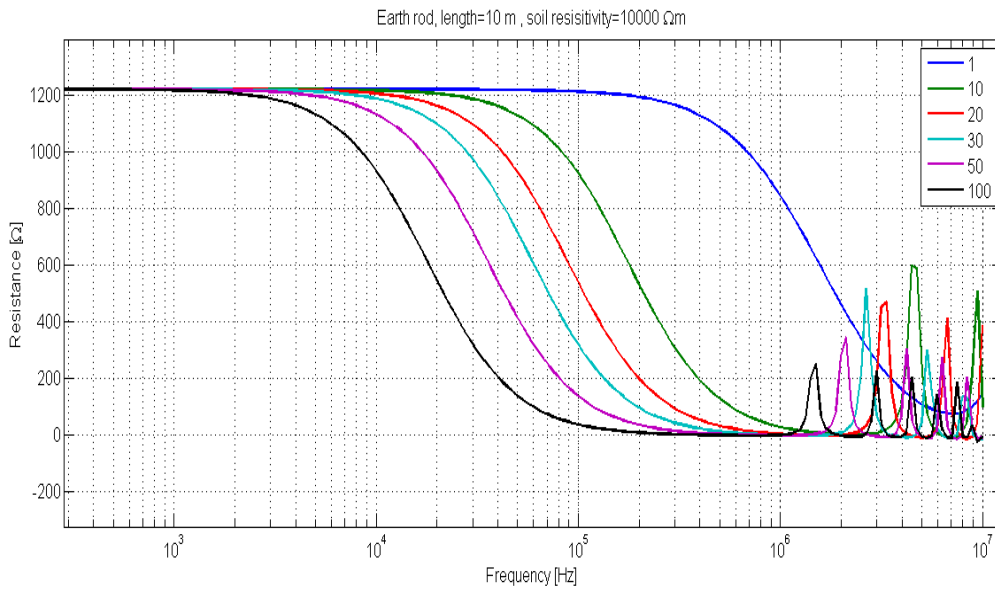
- 1) 10 metres long earthing rod in soil with resistivity of 500 Ohmm and different relative permittivity



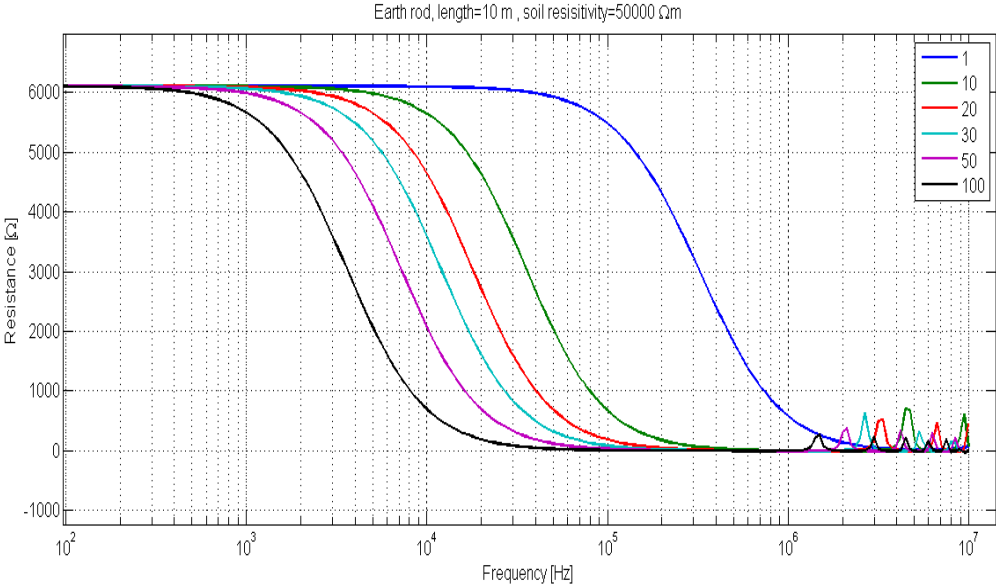
- 2) 10 metres long earthing rod in soil with resistivity of 5000 Ohmm and different relative permittivity



- 3) 10 metres long earthing rod in soil with resistivity of 10000 Ohmm and different relative permittivity



4) 10 metres long earthing rod in soil with resistivity of 50000 Ohmm and different relative permittivity



## Appendix B

### Text files used in SESScript for generating multiple input files for HIFREQ

#### *Earthing rod*

```
HIFREQ
OPTIONS
  UNITS, METRIC
  PRINTOUT, DETAILED
SYSTEM
  ENERGIZATION, LEAD,1,0,,,,,unit
  CHARACTERISTICS

NETWORK
  MAIN-GROUND
    CONDUCTOR,-1, 0, 0, 0,0,0,.1,0,0,<%Out.WriteText Context.Parameters("Length")%>,.0067056, 20,0
    CONDUCTOR, 0, 0, 0, 1,0,0,0,0,0,.1,.0067056, 1,0
COMPUTATIONS
  DETERMINE
    GPR, ON
    POTENTIAL-SCALAR, OFF
    ELECTRIC, OFF
    MAGNETIC, OFF
    VECTOR-POTENTIAL, OFF
    GRADIENT-SCALAR, OFF
    CURRENTS, COMPUTED
  FREQUENCY, 60, 60
  INDIVIDUAL, 1
  INDIVIDUAL, 1.258925412
  INDIVIDUAL, 1.584893192
  INDIVIDUAL, 1.995262315
  INDIVIDUAL, 2.511886432
  INDIVIDUAL, 3.16227766
  INDIVIDUAL, 3.981071706
  INDIVIDUAL, 5.011872336
  INDIVIDUAL, 6.309573445
  INDIVIDUAL, 7.943282347
  INDIVIDUAL, 10
  INDIVIDUAL, 12.58925412
  INDIVIDUAL, 15.84893192
  INDIVIDUAL, 19.95262315
  INDIVIDUAL, 25.11886432
  INDIVIDUAL, 31.6227766
  INDIVIDUAL, 39.81071706
  INDIVIDUAL, 50.11872336
  INDIVIDUAL, 63.09573445
  INDIVIDUAL, 79.43282347
  INDIVIDUAL, 100
```



INDIVIDUAL, 125.8925412  
INDIVIDUAL, 158.4893192  
INDIVIDUAL, 199.5262315  
INDIVIDUAL, 251.1886432  
INDIVIDUAL, 316.227766  
INDIVIDUAL, 398.1071706  
INDIVIDUAL, 501.1872336  
INDIVIDUAL, 630.9573445  
INDIVIDUAL, 794.3282347  
INDIVIDUAL, 1000  
INDIVIDUAL, 1258.925412  
INDIVIDUAL, 1584.893192  
INDIVIDUAL, 1995.262315  
INDIVIDUAL, 2511.886432  
INDIVIDUAL, 3162.27766  
INDIVIDUAL, 3981.071706  
INDIVIDUAL, 5011.872336  
INDIVIDUAL, 6309.573445  
INDIVIDUAL, 7943.282347  
INDIVIDUAL, 10000  
INDIVIDUAL, 12589.25412  
INDIVIDUAL, 15848.93192  
INDIVIDUAL, 19952.62315  
INDIVIDUAL, 25118.86432  
INDIVIDUAL, 31622.7766  
INDIVIDUAL, 39810.71706  
INDIVIDUAL, 50118.72336  
INDIVIDUAL, 63095.73445  
INDIVIDUAL, 79432.82347  
INDIVIDUAL, 100000  
INDIVIDUAL, 105925.3725  
INDIVIDUAL, 112201.8454  
INDIVIDUAL, 118850.2227  
INDIVIDUAL, 125892.5412  
INDIVIDUAL, 133352.1432  
INDIVIDUAL, 141253.7545  
INDIVIDUAL, 149623.5656  
INDIVIDUAL, 158489.3192  
INDIVIDUAL, 167880.4018  
INDIVIDUAL, 177827.941  
INDIVIDUAL, 188364.9089  
INDIVIDUAL, 199526.2315  
INDIVIDUAL, 211348.904  
INDIVIDUAL, 223872.1139  
INDIVIDUAL, 237137.3706  
INDIVIDUAL, 251188.6432  
INDIVIDUAL, 266072.506  
INDIVIDUAL, 281838.2931

INDIVIDUAL, 298538.2619  
INDIVIDUAL, 316227.766  
INDIVIDUAL, 334965.4392  
INDIVIDUAL, 354813.3892  
INDIVIDUAL, 375837.4043  
INDIVIDUAL, 398107.1706  
INDIVIDUAL, 421696.5034  
INDIVIDUAL, 446683.5922  
INDIVIDUAL, 473151.259  
INDIVIDUAL, 501187.2336  
INDIVIDUAL, 530884.4442  
INDIVIDUAL, 562341.3252  
INDIVIDUAL, 595662.1435  
INDIVIDUAL, 630957.3445  
INDIVIDUAL, 668343.9176  
INDIVIDUAL, 707945.7844  
INDIVIDUAL, 749894.2093  
INDIVIDUAL, 794328.2347  
INDIVIDUAL, 841395.1416  
INDIVIDUAL, 891250.9381  
INDIVIDUAL, 944060.8763  
INDIVIDUAL, 1000000  
INDIVIDUAL, 1029200.527  
INDIVIDUAL, 1059253.725  
INDIVIDUAL, 1090184.492  
INDIVIDUAL, 1122018.454  
INDIVIDUAL, 1154781.985  
INDIVIDUAL, 1188502.227  
INDIVIDUAL, 1223207.119  
INDIVIDUAL, 1258925.412  
INDIVIDUAL, 1295686.698  
INDIVIDUAL, 1333521.432  
INDIVIDUAL, 1372460.961  
INDIVIDUAL, 1412537.545  
INDIVIDUAL, 1453784.386  
INDIVIDUAL, 1496235.656  
INDIVIDUAL, 1539926.526  
INDIVIDUAL, 1584893.192  
INDIVIDUAL, 1631172.909  
INDIVIDUAL, 1678804.018  
INDIVIDUAL, 1727825.981  
INDIVIDUAL, 1778279.41  
INDIVIDUAL, 1830206.106  
INDIVIDUAL, 1883649.089  
INDIVIDUAL, 1938652.636  
INDIVIDUAL, 1995262.315  
INDIVIDUAL, 2053525.026  
INDIVIDUAL, 2113489.04

INDIVIDUAL, 2175204.034  
INDIVIDUAL, 2238721.139  
INDIVIDUAL, 2304092.976  
INDIVIDUAL, 2371373.706  
INDIVIDUAL, 2440619.068  
INDIVIDUAL, 2511886.432  
INDIVIDUAL, 2585234.84  
INDIVIDUAL, 2660725.06  
INDIVIDUAL, 2738419.634  
INDIVIDUAL, 2818382.931  
INDIVIDUAL, 2900681.199  
INDIVIDUAL, 2985382.619  
INDIVIDUAL, 3072557.365  
INDIVIDUAL, 3162277.66  
INDIVIDUAL, 3254617.835  
INDIVIDUAL, 3349654.392  
INDIVIDUAL, 3447466.066  
INDIVIDUAL, 3548133.892  
INDIVIDUAL, 3651741.273  
INDIVIDUAL, 3758374.043  
INDIVIDUAL, 3868120.546  
INDIVIDUAL, 3981071.706  
INDIVIDUAL, 4097321.098  
INDIVIDUAL, 4216965.034  
INDIVIDUAL, 4340102.636  
INDIVIDUAL, 4466835.922  
INDIVIDUAL, 4597269.885  
INDIVIDUAL, 4731512.59  
INDIVIDUAL, 4869675.252  
INDIVIDUAL, 5011872.336  
INDIVIDUAL, 5158221.651  
INDIVIDUAL, 5308844.442  
INDIVIDUAL, 5463865.499  
INDIVIDUAL, 5623413.252  
INDIVIDUAL, 5787619.883  
INDIVIDUAL, 5956621.435  
INDIVIDUAL, 6130557.921  
INDIVIDUAL, 6309573.445  
INDIVIDUAL, 6493816.316  
INDIVIDUAL, 6683439.176  
INDIVIDUAL, 6878599.123  
INDIVIDUAL, 7079457.844  
INDIVIDUAL, 7286181.745  
INDIVIDUAL, 7498942.093  
INDIVIDUAL, 7717915.156  
INDIVIDUAL, 7943282.347  
INDIVIDUAL, 8175230.379  
INDIVIDUAL, 8413951.416

INDIVIDUAL, 8659643.234  
INDIVIDUAL, 8912509.381  
INDIVIDUAL, 9172759.354  
INDIVIDUAL, 9440608.763  
INDIVIDUAL, 9716279.516  
INDIVIDUAL, 9999999

SOIL-TYPE,LIMITED-LAYE  
UNIFORM, AIR,1E+18,1,1  
UNIFORM, EARTH,<%Out.WriteText Context.Parameters("Resistivity")%>,1,<%Out.WriteText  
Context.Parameters("Relative Permittivity")%>  
ENDPROGRAM

### ***Counterpoise electrode***

HIFREQ  
OPTIONS  
UNITS, METRIC  
PRINTOUT, DETAILED  
SYSTEM  
TOLERANCE,0.001,1.,0.005,0.00005,0.001,0.,0,0,0.5  
ENERGIZATION, LEAD,1,0,,,,,,unit  
CHARACTERISTICS  
  
SUBDIVISION,YES,  
SOIL-INTERFACE-OPTION,ERROR  
NETWORK  
MAIN-GROUND  
CONDUCTOR,-1, 0, 0, 0,0,0,.5,<%Out.WriteText Context.Parameters("Length")%>,0,.5,.005, 40,0  
CONDUCTOR,-1, 0, 0, 0,0,0,.5,-<%Out.WriteText Context.Parameters("Length")%>,0,.5,.005, 40,0  
CONDUCTOR,-1, 0, 0, 0,0,0,.5,0,<%Out.WriteText Context.Parameters("Length")%>,.5,.005, 40,0  
CONDUCTOR,-1, 0, 0, 0,0,0,.5,0,-<%Out.WriteText Context.Parameters("Length")%>,.5,.005, 40,0  
CONDUCTOR,-1, 0, 0, 0,0,0,.1,0,0,.5,.005, 10,0  
CONDUCTOR, 0, 0, 0, 1,0,0,0,0,0,.1,.005, 1,0  
COMPUTATIONS  
DETERMINE  
GPR, ON  
POTENTIAL-SCALAR, OFF  
ELECTRIC, OFF  
MAGNETIC, OFF  
VECTOR-POTENTIAL, OFF  
GRADIENT-SCALAR, OFF  
CURRENTS, COMPUTED  
FREQUENCY, 60, 60  
INDIVIDUAL, 1  
INDIVIDUAL, 1.258925412  
INDIVIDUAL, 1.584893192  
INDIVIDUAL, 1.995262315  
INDIVIDUAL, 2.511886432

INDIVIDUAL, 3.16227766  
INDIVIDUAL, 3.981071706  
INDIVIDUAL, 5.011872336  
INDIVIDUAL, 6.309573445  
INDIVIDUAL, 7.943282347  
INDIVIDUAL, 10  
INDIVIDUAL, 12.58925412  
INDIVIDUAL, 15.84893192  
INDIVIDUAL, 19.95262315  
INDIVIDUAL, 25.11886432  
INDIVIDUAL, 31.6227766  
INDIVIDUAL, 39.81071706  
INDIVIDUAL, 50.11872336  
INDIVIDUAL, 63.09573445  
INDIVIDUAL, 79.43282347  
INDIVIDUAL, 100  
INDIVIDUAL, 125.8925412  
INDIVIDUAL, 158.4893192  
INDIVIDUAL, 199.5262315  
INDIVIDUAL, 251.1886432  
INDIVIDUAL, 316.227766  
INDIVIDUAL, 398.1071706  
INDIVIDUAL, 501.1872336  
INDIVIDUAL, 630.9573445  
INDIVIDUAL, 794.3282347  
INDIVIDUAL, 1000  
INDIVIDUAL, 1258.925412  
INDIVIDUAL, 1584.893192  
INDIVIDUAL, 1995.262315  
INDIVIDUAL, 2511.886432  
INDIVIDUAL, 3162.27766  
INDIVIDUAL, 3981.071706  
INDIVIDUAL, 5011.872336  
INDIVIDUAL, 6309.573445  
INDIVIDUAL, 7943.282347  
INDIVIDUAL, 10000  
INDIVIDUAL, 12589.25412  
INDIVIDUAL, 15848.93192  
INDIVIDUAL, 19952.62315  
INDIVIDUAL, 25118.86432  
INDIVIDUAL, 31622.7766  
INDIVIDUAL, 39810.71706  
INDIVIDUAL, 50118.72336  
INDIVIDUAL, 63095.73445  
INDIVIDUAL, 79432.82347  
INDIVIDUAL, 100000  
INDIVIDUAL, 105925.3725  
INDIVIDUAL, 112201.8454

INDIVIDUAL, 118850.2227  
INDIVIDUAL, 125892.5412  
INDIVIDUAL, 133352.1432  
INDIVIDUAL, 141253.7545  
INDIVIDUAL, 149623.5656  
INDIVIDUAL, 158489.3192  
INDIVIDUAL, 167880.4018  
INDIVIDUAL, 177827.941  
INDIVIDUAL, 188364.9089  
INDIVIDUAL, 199526.2315  
INDIVIDUAL, 211348.904  
INDIVIDUAL, 223872.1139  
INDIVIDUAL, 237137.3706  
INDIVIDUAL, 251188.6432  
INDIVIDUAL, 266072.506  
INDIVIDUAL, 281838.2931  
INDIVIDUAL, 298538.2619  
INDIVIDUAL, 316227.766  
INDIVIDUAL, 334965.4392  
INDIVIDUAL, 354813.3892  
INDIVIDUAL, 375837.4043  
INDIVIDUAL, 398107.1706  
INDIVIDUAL, 421696.5034  
INDIVIDUAL, 446683.5922  
INDIVIDUAL, 473151.259  
INDIVIDUAL, 501187.2336  
INDIVIDUAL, 530884.4442  
INDIVIDUAL, 562341.3252  
INDIVIDUAL, 595662.1435  
INDIVIDUAL, 630957.3445  
INDIVIDUAL, 668343.9176  
INDIVIDUAL, 707945.7844  
INDIVIDUAL, 749894.2093  
INDIVIDUAL, 794328.2347  
INDIVIDUAL, 841395.1416  
INDIVIDUAL, 891250.9381  
INDIVIDUAL, 944060.8763  
INDIVIDUAL, 1000000  
INDIVIDUAL, 1029200.527  
INDIVIDUAL, 1059253.725  
INDIVIDUAL, 1090184.492  
INDIVIDUAL, 1122018.454  
INDIVIDUAL, 1154781.985  
INDIVIDUAL, 1188502.227  
INDIVIDUAL, 1223207.119  
INDIVIDUAL, 1258925.412  
INDIVIDUAL, 1295686.698  
INDIVIDUAL, 1333521.432

INDIVIDUAL, 1372460.961  
INDIVIDUAL, 1412537.545  
INDIVIDUAL, 1453784.386  
INDIVIDUAL, 1496235.656  
INDIVIDUAL, 1539926.526  
INDIVIDUAL, 1584893.192  
INDIVIDUAL, 1631172.909  
INDIVIDUAL, 1678804.018  
INDIVIDUAL, 1727825.981  
INDIVIDUAL, 1778279.41  
INDIVIDUAL, 1830206.106  
INDIVIDUAL, 1883649.089  
INDIVIDUAL, 1938652.636  
INDIVIDUAL, 1995262.315  
INDIVIDUAL, 2053525.026  
INDIVIDUAL, 2113489.04  
INDIVIDUAL, 2175204.034  
INDIVIDUAL, 2238721.139  
INDIVIDUAL, 2304092.976  
INDIVIDUAL, 2371373.706  
INDIVIDUAL, 2440619.068  
INDIVIDUAL, 2511886.432  
INDIVIDUAL, 2585234.84  
INDIVIDUAL, 2660725.06  
INDIVIDUAL, 2738419.634  
INDIVIDUAL, 2818382.931  
INDIVIDUAL, 2900681.199  
INDIVIDUAL, 2985382.619  
INDIVIDUAL, 3072557.365  
INDIVIDUAL, 3162277.66  
INDIVIDUAL, 3254617.835  
INDIVIDUAL, 3349654.392  
INDIVIDUAL, 3447466.066  
INDIVIDUAL, 3548133.892  
INDIVIDUAL, 3651741.273  
INDIVIDUAL, 3758374.043  
INDIVIDUAL, 3868120.546  
INDIVIDUAL, 3981071.706  
INDIVIDUAL, 4097321.098  
INDIVIDUAL, 4216965.034  
INDIVIDUAL, 4340102.636  
INDIVIDUAL, 4466835.922  
INDIVIDUAL, 4597269.885  
INDIVIDUAL, 4731512.59  
INDIVIDUAL, 4869675.252  
INDIVIDUAL, 5011872.336  
INDIVIDUAL, 5158221.651  
INDIVIDUAL, 5308844.442

INDIVIDUAL, 5463865.499  
INDIVIDUAL, 5623413.252  
INDIVIDUAL, 5787619.883  
INDIVIDUAL, 5956621.435  
INDIVIDUAL, 6130557.921  
INDIVIDUAL, 6309573.445  
INDIVIDUAL, 6493816.316  
INDIVIDUAL, 6683439.176  
INDIVIDUAL, 6878599.123  
INDIVIDUAL, 7079457.844  
INDIVIDUAL, 7286181.745  
INDIVIDUAL, 7498942.093  
INDIVIDUAL, 7717915.156  
INDIVIDUAL, 7943282.347  
INDIVIDUAL, 8175230.379  
INDIVIDUAL, 8413951.416  
INDIVIDUAL, 8659643.234  
INDIVIDUAL, 8912509.381  
INDIVIDUAL, 9172759.354  
INDIVIDUAL, 9440608.763  
INDIVIDUAL, 9716279.516  
INDIVIDUAL, 9999999

SOIL-TYPE,LIMITED-LAYE

UNIFORM, AIR,1E+18,1,1

UNIFORM, EARTH,<%Out.WriteText Context.Parameters("Resistivity")%>,1,<%Out.WriteText  
Context.Parameters("Permittivity")%>

ENDPROGRAM

### ***Ring electrode***

<%

Dim ScaleFactor

ScaleFactor = Context.Parameters("ScaleFactor")

%>

HIFREQ

COMPONENTS

TEMPLATES

HELIX, 1, 1, .5, .5, 1

SEGMENTS, PER-TURN, 50

TRANSFORMATION, 0, 0, 0, 1, 0, 0, 0, 1, 0, 0, 0, 1

CHARACTERISTICS, EXPLICIT, -1, 0, 0, 0, 0, .005, 1, 10

GROUP, , 0, 1

OPTIONS



UNITS, METRIC  
PRINTOUT, DETAILED  
SOIL-TYPE,LIMITED-LAYE  
UNIFORM, AIR,1E+18,1,1  
UNIFORM, EARTH,<%Out.WriteText Context.Parameters("Resistivity")%>,1,<%Out.WriteText  
Context.Parameters("Permittivity")%>  
SYSTEM  
ENERGIZATION, LEAD,1,0,,,,,Unit  
CHARACTERISTICS

NETWORK

MAIN-GROUND

<%

Out.Indent=8

Transform.ApplyScaling ScaleFactor , ScaleFactor, 1, 0, 0, 1

Out.HIFREQConductor -1, 0, 0, 0,1,0,.5,.992114701314,.125333233564,.5,.005, 1,1

Out.HIFREQConductor -1, 0, 0,

0,.992114701314,.125333233564,.5,.968583161129,.248689887165,.5,.005, 1,1

Out.HIFREQConductor -1, 0, 0,

0,.968583161129,.248689887165,.5,.929776485888,.368124552685,.5,.005, 1,1

Out.HIFREQConductor -1, 0, 0,

0,.929776485888,.368124552685,.5,.876306680044,.481753674102,.5,.005, 1,1

Out.HIFREQConductor -1, 0, 0,

0,.876306680044,.481753674102,.5,.809016994375,.587785252292,.5,.005, 1,1

Out.HIFREQConductor -1, 0, 0,

0,.809016994375,.587785252292,.5,.728968627421,.684547105929,.5,.005, 1,1

Out.HIFREQConductor -1, 0, 0,

0,.728968627421,.684547105929,.5,.637423989749,.770513242776,.5,.005, 1,1

Out.HIFREQConductor -1, 0, 0,

0,.637423989749,.770513242776,.5,.535826794979,.844327925502,.5,.005, 1,1

Out.HIFREQConductor -1, 0, 0,

0,.535826794979,.844327925502,.5,.425779291565,.904827052466,.5,.005, 1,1

Out.HIFREQConductor -1, 0, 0,

0,.425779291565,.904827052466,.5,.309016994375,.951056516295,.5,.005, 1,1

Out.HIFREQConductor -1, 0, 0,

0,.309016994375,.951056516295,.5,.187381314586,.982287250729,.5,.005, 1,1

Out.HIFREQConductor -1, 0, 0,

0,.187381314586,.982287250729,.5,.0627905195293,.998026728428,.5,.005, 1,1

Out.HIFREQConductor -1, 0, 0, 0,.0627905195293,.998026728428,.5,-

.0627905195293,.998026728428,.5,.005, 1,1

Out.HIFREQConductor -1, 0, 0, 0,-.0627905195293,.998026728428,.5,-

.187381314586,.982287250729,.5,.005, 1,1

Out.HIFREQConductor -1, 0, 0, 0,-.187381314586,.982287250729,.5,-

.309016994375,.951056516295,.5,.005, 1,1

Out.HIFREQConductor -1, 0, 0, 0,-.309016994375,.951056516295,.5,-

.425779291565,.904827052466,.5,.005, 1,1

Out.HIFREQConductor -1, 0, 0, 0,-.425779291565,.904827052466,.5,-

.535826794979,.844327925502,.5,.005, 1,1

Out.HIFREQConductor -1, 0, 0, 0,-.535826794979,.844327925502,.5,-  
 .637423989749,.770513242776,.5,.005, 1,1  
 Out.HIFREQConductor -1, 0, 0, 0,-.637423989749,.770513242776,.5,-  
 .728968627421,.684547105929,.5,.005, 1,1  
 Out.HIFREQConductor -1, 0, 0, 0,-.728968627421,.684547105929,.5,-  
 .809016994375,.587785252292,.5,.005, 1,1  
 Out.HIFREQConductor -1, 0, 0, 0,-.809016994375,.587785252292,.5,-  
 .876306680044,.481753674102,.5,.005, 1,1  
 Out.HIFREQConductor -1, 0, 0, 0,-.876306680044,.481753674102,.5,-  
 .929776485888,.368124552685,.5,.005, 1,1  
 Out.HIFREQConductor -1, 0, 0, 0,-.929776485888,.368124552685,.5,-  
 .968583161129,.248689887165,.5,.005, 1,1  
 Out.HIFREQConductor -1, 0, 0, 0,-.968583161129,.248689887165,.5,-  
 .992114701314,.125333233564,.5,.005, 1,1  
 Out.HIFREQConductor -1, 0, 0, 0,-.992114701314,.125333233564,.5,-1,3.23108510433E-15,.5,.005,  
 1,1  
 Out.HIFREQConductor -1, 0, 0, 0,-1,3.23108510433E-15,.5,-.992114701314,-.125333233564,.5,.005,  
 1,1  
 Out.HIFREQConductor -1, 0, 0, 0,-.992114701314,-.125333233564,.5,-.968583161129,-  
 .248689887165,.5,.005, 1,1  
 Out.HIFREQConductor -1, 0, 0, 0,-.968583161129,-.248689887165,.5,-.929776485888,-  
 .368124552685,.5,.005, 1,1  
 Out.HIFREQConductor -1, 0, 0, 0,-.929776485888,-.368124552685,.5,-.876306680044,-  
 .481753674102,.5,.005, 1,1  
 Out.HIFREQConductor -1, 0, 0, 0,-.876306680044,-.481753674102,.5,-.809016994375,-  
 .587785252292,.5,.005, 1,1  
 Out.HIFREQConductor -1, 0, 0, 0,-.809016994375,-.587785252292,.5,-.728968627421,-  
 .684547105929,.5,.005, 1,1  
 Out.HIFREQConductor -1, 0, 0, 0,-.728968627421,-.684547105929,.5,-.637423989749,-  
 .770513242776,.5,.005, 1,1  
 Out.HIFREQConductor -1, 0, 0, 0,-.637423989749,-.770513242776,.5,-.535826794979,-  
 .844327925502,.5,.005, 1,1  
 Out.HIFREQConductor -1, 0, 0, 0,-.535826794979,-.844327925502,.5,-.425779291565,-  
 .904827052466,.5,.005, 1,1  
 Out.HIFREQConductor -1, 0, 0, 0,-.425779291565,-.904827052466,.5,-.309016994375,-  
 .951056516295,.5,.005, 1,1  
 Out.HIFREQConductor -1, 0, 0, 0,-.309016994375,-.951056516295,.5,-.187381314586,-  
 .982287250729,.5,.005, 1,1  
 Out.HIFREQConductor -1, 0, 0, 0,-.187381314586,-.982287250729,.5,-.0627905195293,-  
 .998026728428,.5,.005, 1,1  
 Out.HIFREQConductor -1, 0, 0, 0,-.0627905195293,-.998026728428,.5,.0627905195293,-  
 .998026728428,.5,.005, 1,1  
 Out.HIFREQConductor -1, 0, 0, 0,.0627905195293,-.998026728428,.5,.187381314586,-  
 .982287250729,.5,.005, 1,1  
 Out.HIFREQConductor -1, 0, 0, 0,.187381314586,-.982287250729,.5,.309016994375,-  
 .951056516295,.5,.005, 1,1  
 Out.HIFREQConductor -1, 0, 0, 0,.309016994375,-.951056516295,.5,.425779291565,-  
 .904827052466,.5,.005, 1,1

Out.HIFREQConductor -1, 0, 0, 0,.425779291565,-.904827052466,.5,.535826794979,-  
 .844327925502,.5,.005, 1,1  
 Out.HIFREQConductor -1, 0, 0, 0,.535826794979,-.844327925502,.5,.637423989749,-  
 .770513242776,.5,.005, 1,1  
 Out.HIFREQConductor -1, 0, 0, 0,.637423989749,-.770513242776,.5,.728968627421,-  
 .684547105929,.5,.005, 1,1  
 Out.HIFREQConductor -1, 0, 0, 0,.728968627421,-.684547105929,.5,.809016994375,-  
 .587785252292,.5,.005, 1,1  
 Out.HIFREQConductor -1, 0, 0, 0,.809016994375,-.587785252292,.5,.876306680044,-  
 .481753674102,.5,.005, 1,1  
 Out.HIFREQConductor -1, 0, 0, 0,.876306680044,-.481753674102,.5,.929776485888,-  
 .368124552685,.5,.005, 1,1  
 Out.HIFREQConductor -1, 0, 0, 0,.929776485888,-.368124552685,.5,.968583161129,-  
 .248689887165,.5,.005, 1,1  
 Out.HIFREQConductor -1, 0, 0, 0,.968583161129,-.248689887165,.5,.992114701314,-  
 .125333233564,.5,.005, 1,1  
 Out.HIFREQConductor -1, 0, 0, 0,.992114701314,-.125333233564,.5,1,-6.46217020867E-15,.5,.005,  
 1,1  
 Out.HIFREQConductor -1, 0, 0, 0,1,0,.1,1,0,.5,.0067056, 1,0  
 Out.HIFREQConductor 0, 0, 0, 1,1,0,0,1,0,.1,.0067056, 1,0

%>

ENDMODULE

COMPUTATIONS

DETERMINE

GPR, ON

POTENTIAL-SCALAR, OFF

ELECTRIC, OFF

MAGNETIC, OFF

VECTOR-POTENTIAL, OFF

GRADIENT-SCALAR, OFF

CURRENTS, COMPUTED

OBSERVATION

FREQUENCY, 60, 60

INDIVIDUAL, 1

INDIVIDUAL, 1.258925412

INDIVIDUAL, 1.584893192

INDIVIDUAL, 1.995262315

INDIVIDUAL, 2.511886432

INDIVIDUAL, 3.16227766

INDIVIDUAL, 3.981071706

INDIVIDUAL, 5.011872336

INDIVIDUAL, 6.309573445

INDIVIDUAL, 7.943282347

INDIVIDUAL, 10

INDIVIDUAL, 12.58925412

INDIVIDUAL, 15.84893192

INDIVIDUAL, 19.95262315

INDIVIDUAL, 25.11886432

INDIVIDUAL, 31.6227766  
INDIVIDUAL, 39.81071706  
INDIVIDUAL, 50.11872336  
INDIVIDUAL, 63.09573445  
INDIVIDUAL, 79.43282347  
INDIVIDUAL, 100  
INDIVIDUAL, 125.8925412  
INDIVIDUAL, 158.4893192  
INDIVIDUAL, 199.5262315  
INDIVIDUAL, 251.1886432  
INDIVIDUAL, 316.227766  
INDIVIDUAL, 398.1071706  
INDIVIDUAL, 501.1872336  
INDIVIDUAL, 630.9573445  
INDIVIDUAL, 794.3282347  
INDIVIDUAL, 1000  
INDIVIDUAL, 1258.925412  
INDIVIDUAL, 1584.893192  
INDIVIDUAL, 1995.262315  
INDIVIDUAL, 2511.886432  
INDIVIDUAL, 3162.27766  
INDIVIDUAL, 3981.071706  
INDIVIDUAL, 5011.872336  
INDIVIDUAL, 6309.573445  
INDIVIDUAL, 7943.282347  
INDIVIDUAL, 10000  
INDIVIDUAL, 12589.25412  
INDIVIDUAL, 15848.93192  
INDIVIDUAL, 19952.62315  
INDIVIDUAL, 25118.86432  
INDIVIDUAL, 31622.7766  
INDIVIDUAL, 39810.71706  
INDIVIDUAL, 50118.72336  
INDIVIDUAL, 63095.73445  
INDIVIDUAL, 79432.82347  
INDIVIDUAL, 100000  
INDIVIDUAL, 105925.3725  
INDIVIDUAL, 112201.8454  
INDIVIDUAL, 118850.2227  
INDIVIDUAL, 125892.5412  
INDIVIDUAL, 133352.1432  
INDIVIDUAL, 141253.7545  
INDIVIDUAL, 149623.5656  
INDIVIDUAL, 158489.3192  
INDIVIDUAL, 167880.4018  
INDIVIDUAL, 177827.941  
INDIVIDUAL, 188364.9089  
INDIVIDUAL, 199526.2315

INDIVIDUAL, 211348.904  
INDIVIDUAL, 223872.1139  
INDIVIDUAL, 237137.3706  
INDIVIDUAL, 251188.6432  
INDIVIDUAL, 266072.506  
INDIVIDUAL, 281838.2931  
INDIVIDUAL, 298538.2619  
INDIVIDUAL, 316227.766  
INDIVIDUAL, 334965.4392  
INDIVIDUAL, 354813.3892  
INDIVIDUAL, 375837.4043  
INDIVIDUAL, 398107.1706  
INDIVIDUAL, 421696.5034  
INDIVIDUAL, 446683.5922  
INDIVIDUAL, 473151.259  
INDIVIDUAL, 501187.2336  
INDIVIDUAL, 530884.4442  
INDIVIDUAL, 562341.3252  
INDIVIDUAL, 595662.1435  
INDIVIDUAL, 630957.3445  
INDIVIDUAL, 668343.9176  
INDIVIDUAL, 707945.7844  
INDIVIDUAL, 749894.2093  
INDIVIDUAL, 794328.2347  
INDIVIDUAL, 841395.1416  
INDIVIDUAL, 891250.9381  
INDIVIDUAL, 944060.8763  
INDIVIDUAL, 1000000  
INDIVIDUAL, 1029200.527  
INDIVIDUAL, 1059253.725  
INDIVIDUAL, 1090184.492  
INDIVIDUAL, 1122018.454  
INDIVIDUAL, 1154781.985  
INDIVIDUAL, 1188502.227  
INDIVIDUAL, 1223207.119  
INDIVIDUAL, 1258925.412  
INDIVIDUAL, 1295686.698  
INDIVIDUAL, 1333521.432  
INDIVIDUAL, 1372460.961  
INDIVIDUAL, 1412537.545  
INDIVIDUAL, 1453784.386  
INDIVIDUAL, 1496235.656  
INDIVIDUAL, 1539926.526  
INDIVIDUAL, 1584893.192  
INDIVIDUAL, 1631172.909  
INDIVIDUAL, 1678804.018  
INDIVIDUAL, 1727825.981  
INDIVIDUAL, 1778279.41

INDIVIDUAL, 1830206.106  
INDIVIDUAL, 1883649.089  
INDIVIDUAL, 1938652.636  
INDIVIDUAL, 1995262.315  
INDIVIDUAL, 2053525.026  
INDIVIDUAL, 2113489.04  
INDIVIDUAL, 2175204.034  
INDIVIDUAL, 2238721.139  
INDIVIDUAL, 2304092.976  
INDIVIDUAL, 2371373.706  
INDIVIDUAL, 2440619.068  
INDIVIDUAL, 2511886.432  
INDIVIDUAL, 2585234.84  
INDIVIDUAL, 2660725.06  
INDIVIDUAL, 2738419.634  
INDIVIDUAL, 2818382.931  
INDIVIDUAL, 2900681.199  
INDIVIDUAL, 2985382.619  
INDIVIDUAL, 3072557.365  
INDIVIDUAL, 3162277.66  
INDIVIDUAL, 3254617.835  
INDIVIDUAL, 3349654.392  
INDIVIDUAL, 3447466.066  
INDIVIDUAL, 3548133.892  
INDIVIDUAL, 3651741.273  
INDIVIDUAL, 3758374.043  
INDIVIDUAL, 3868120.546  
INDIVIDUAL, 3981071.706  
INDIVIDUAL, 4097321.098  
INDIVIDUAL, 4216965.034  
INDIVIDUAL, 4340102.636  
INDIVIDUAL, 4466835.922  
INDIVIDUAL, 4597269.885  
INDIVIDUAL, 4731512.59  
INDIVIDUAL, 4869675.252  
INDIVIDUAL, 5011872.336  
INDIVIDUAL, 5158221.651  
INDIVIDUAL, 5308844.442  
INDIVIDUAL, 5463865.499  
INDIVIDUAL, 5623413.252  
INDIVIDUAL, 5787619.883  
INDIVIDUAL, 5956621.435  
INDIVIDUAL, 6130557.921  
INDIVIDUAL, 6309573.445  
INDIVIDUAL, 6493816.316  
INDIVIDUAL, 6683439.176  
INDIVIDUAL, 6878599.123  
INDIVIDUAL, 7079457.844

INDIVIDUAL, 7286181.745  
INDIVIDUAL, 7498942.093  
INDIVIDUAL, 7717915.156  
INDIVIDUAL, 7943282.347  
INDIVIDUAL, 8175230.379  
INDIVIDUAL, 8413951.416  
INDIVIDUAL, 8659643.234  
INDIVIDUAL, 8912509.381  
INDIVIDUAL, 9172759.354  
INDIVIDUAL, 9440608.763  
INDIVIDUAL, 9716279.516  
INDIVIDUAL, 9999999

ENDMODULE  
ENDPROGRAM

## Appendix C

### Example of an output report from HIFREQ (counterpoise electrode with for radials in the soil with resistivity equal to 100 Ohmm and relative permittivity equal to 1)

DATE OF RUN (Start)= DAY 12 / Month 3 / Year 2013

STARTING TIME= 13:47:35:03

RUNID : SAMPLE TEST RUN                      Frequency Case # 1: 50.0000000 Hz  
GPR of Conductor Metal

```
|----,|----,|----,|----- Conductor Coordinates (meters) -----|            Metal
GPR (Volts)
|Cond.,| Seg.,|Comp.,|----- Conductor Start -----|----- Conductor End -----|
No , No , No , X , Y , Z , X , Y , Z , Magn.,Ang.(deg.),Real Part,Imag.Part
=====,=====,=====,=====,=====,=====,=====,=====,=====,=====,=====
6, 6, 0, 0.0000000, 0.0000000, 0.0000000, 0.0000000, 0.0000000, 0.0000000, 0.1000000,
2.1429558, 0.0379861, 2.1429553, 0.0014207
```

Total Length of Selected Conductors.....: 0.1000000 meters

DATE OF RUN (Start)= DAY 12 / Month 3 / Year 2013

STARTING TIME= 13:47:35:09

RUNID : SAMPLE TEST RUN                      Frequency Case # 2: 1000.0000000 Hz  
GPR of Conductor Metal

```
|----,|----,|----,|----- Conductor Coordinates (meters) -----|            Metal
GPR (Volts)
|Cond.,| Seg.,|Comp.,|----- Conductor Start -----|----- Conductor End -----|
No , No , No , X , Y , Z , X , Y , Z , Magn.,Ang.(deg.),Real Part,Imag.Part
=====,=====,=====,=====,=====,=====,=====,=====,=====,=====,=====
6, 6, 0, 0.0000000, 0.0000000, 0.0000000, 0.0000000, 0.0000000, 0.0000000, 0.1000000,
2.1424272, 0.7790405, 2.1422291, 0.0291293
```

Total Length of Selected Conductors.....: 0.1000000 meters

DATE OF RUN (Start)= DAY 12 / Month 3 / Year 2013

STARTING TIME= 13:47:35:29

RUNID : SAMPLE TEST RUN                      Frequency Case # 3: 10000.0000000 Hz  
GPR of Conductor Metal

```
|----,|----,|----,|----- Conductor Coordinates (meters) -----|            Metal
GPR (Volts)
|Cond.,| Seg.,|Comp.,|----- Conductor Start -----|----- Conductor End -----|
No , No , No , X , Y , Z , X , Y , Z , Magn.,Ang.(deg.),Real Part,Imag.Part
=====,=====,=====,=====,=====,=====,=====,=====,=====,=====,=====
6, 6, 0, 0.0000000, 0.0000000, 0.0000000, 0.0000000, 0.0000000, 0.0000000, 0.1000000,
2.1685197, 7.4439883, 2.1502435, 0.2809467
```

Total Length of Selected Conductors.....: 0.1000000 meters



DATE OF RUN (Start)= DAY 12 / Month 3 / Year 2013

STARTING TIME= 13:47:35:35

RUNID : SAMPLE TEST RUN

Frequency Case # 4: 100000.0000000 Hz

GPR of Conductor Metal

|----,|----,|----,|----- Conductor Coordinates (meters) -----| Metal

GPR (Volts)

|Cond.,| Seg.,|Comp.,|----- Conductor Start -----|----- Conductor End -----|

No , No , No , X , Y , Z , X , Y , Z , Magn.,Ang.(deg.),Real Part,Imag.Part

====,====,====,====,====,====,====,====,====,====,====,====  
6, 6, 0, 0.000000, 0.000000, 0.000000, 0.000000, 0.000000, 0.100000,  
3.7663739, 38.5597649, 2.9451478, 2.3476963

Total Length of Selected Conductors.....: 0.1000000 meters

DATE OF RUN (Start)= DAY 12 / Month 3 / Year 2013

STARTING TIME= 13:47:35:42

RUNID : SAMPLE TEST RUN

Frequency Case # 5: 1000000.0000000 Hz

GPR of Conductor Metal

|----,|----,|----,|----- Conductor Coordinates (meters) -----| Metal

GPR (Volts)

|Cond.,| Seg.,|Comp.,|----- Conductor Start -----|----- Conductor End -----|

No , No , No , X , Y , Z , X , Y , Z , Magn.,Ang.(deg.),Real Part,Imag.Part

====,====,====,====,====,====,====,====,====,====,====,====  
6, 6, 0, 0.000000, 0.000000, 0.000000, 0.000000, 0.000000, 0.100000,  
11.0909004, 41.5777817, 8.2966089, 7.3603230

Total Length of Selected Conductors.....: 0.1000000 meters

DATE OF RUN (Start)= DAY 12 / Month 3 / Year 2013

STARTING TIME= 13:47:35:49

RUNID : SAMPLE TEST RUN

Frequency Case # 6: \*\*\*\*\* Hz

GPR of Conductor Metal

|----,|----,|----,|----- Conductor Coordinates (meters) -----| Metal

GPR (Volts)

|Cond.,| Seg.,|Comp.,|----- Conductor Start -----|----- Conductor End -----|

No , No , No , X , Y , Z , X , Y , Z , Magn.,Ang.(deg.),Real Part,Imag.Part

====,====,====,====,====,====,====,====,====,====,====,====  
6, 6, 0, 0.000000, 0.000000, 0.000000, 0.000000, 0.000000, 0.100000,  
37.5505333, 57.7956200, 20.0122185, 31.7734756

Total Length of Selected Conductors.....: 0.1000000 meters

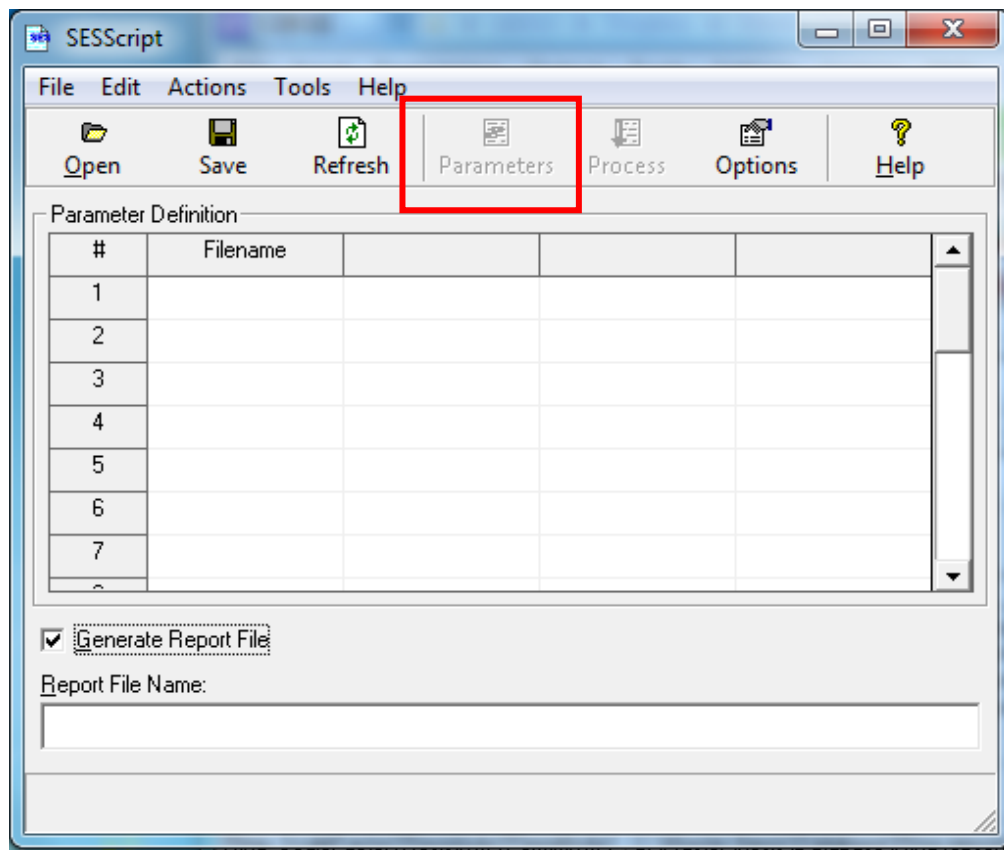
## Appendix D

### Procedure for preparing and processing multiple input files in CDEGS

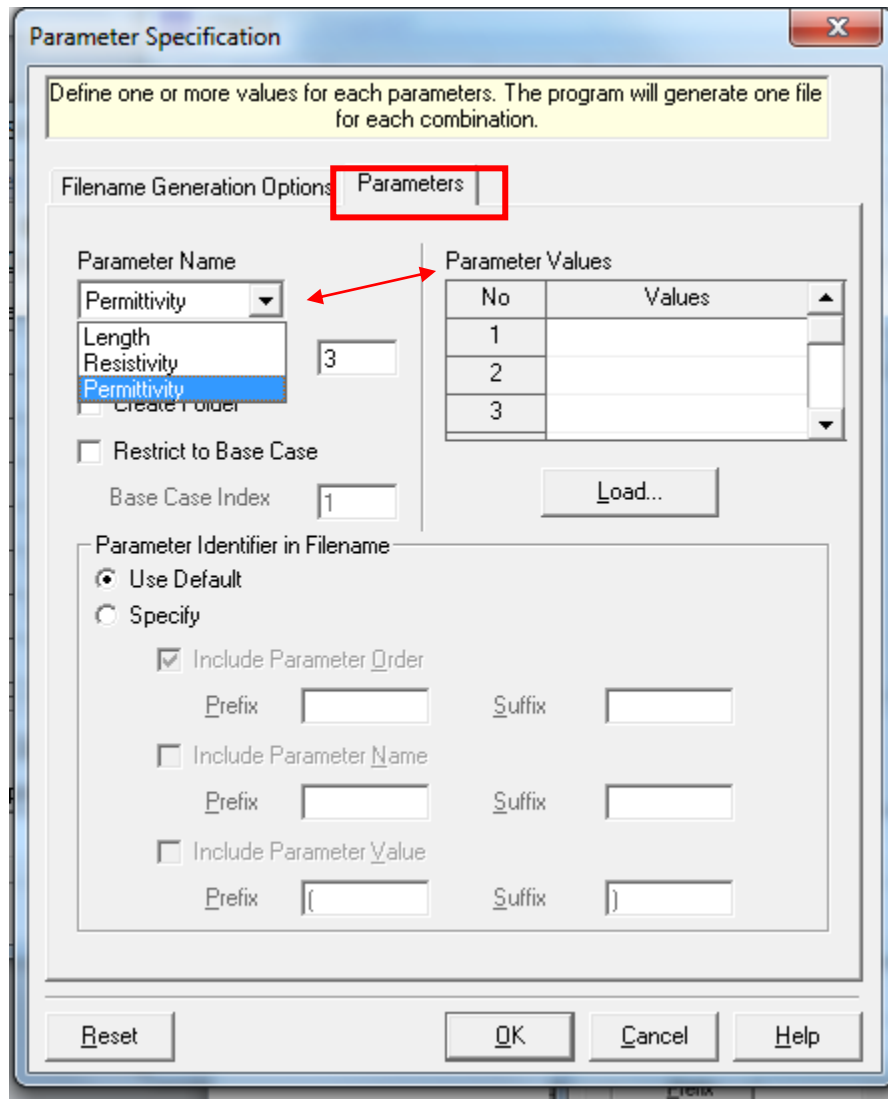
Create a text file describing a case (as shown in Appendix B) and define parameters. Syntax for defining a parameter is `<%Out.WriteText Context.Parameters("Parameter name")%>`.

The easiest way to prepare a text file describing the model is to make a model using SESCAD first and use input file with extension .f05. This type of files can be edited with the help of Notepad ++, and one can save a copy as a text file. File name should start with "hi\_". For more information and examples refer to the Help-files for the software.

Open SESScript tool in CDEGS and chose Open to find the necessary file. 'Parameters' icon becomes active when the text file is opened.

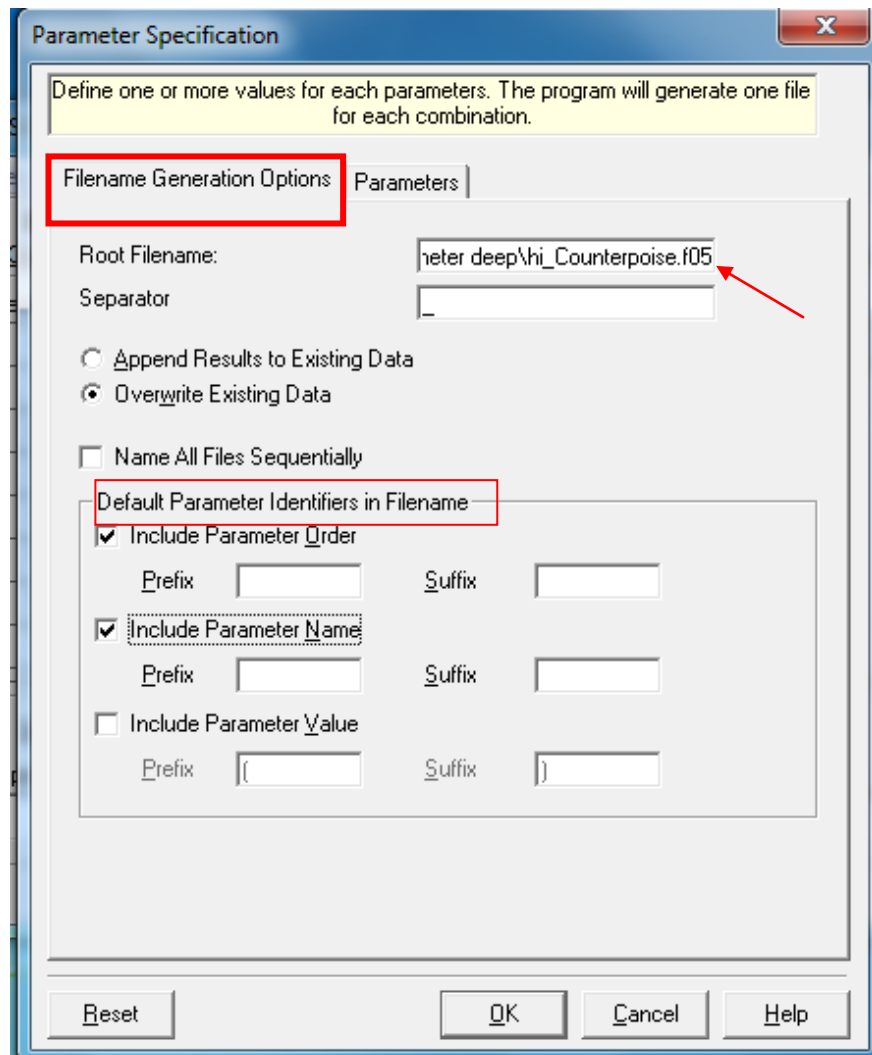


Choosing 'Parameters' opens the window below:

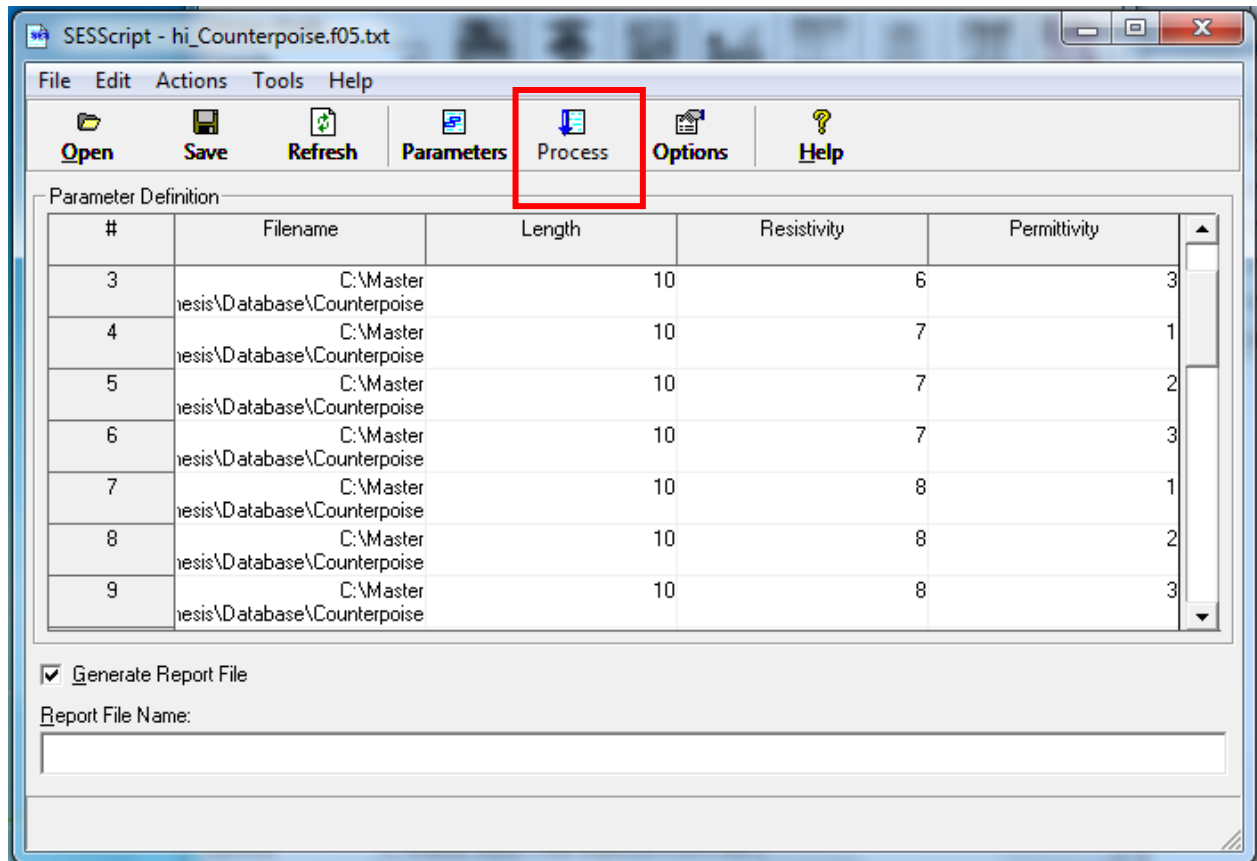


Enter values for each parameter defined in the text file.

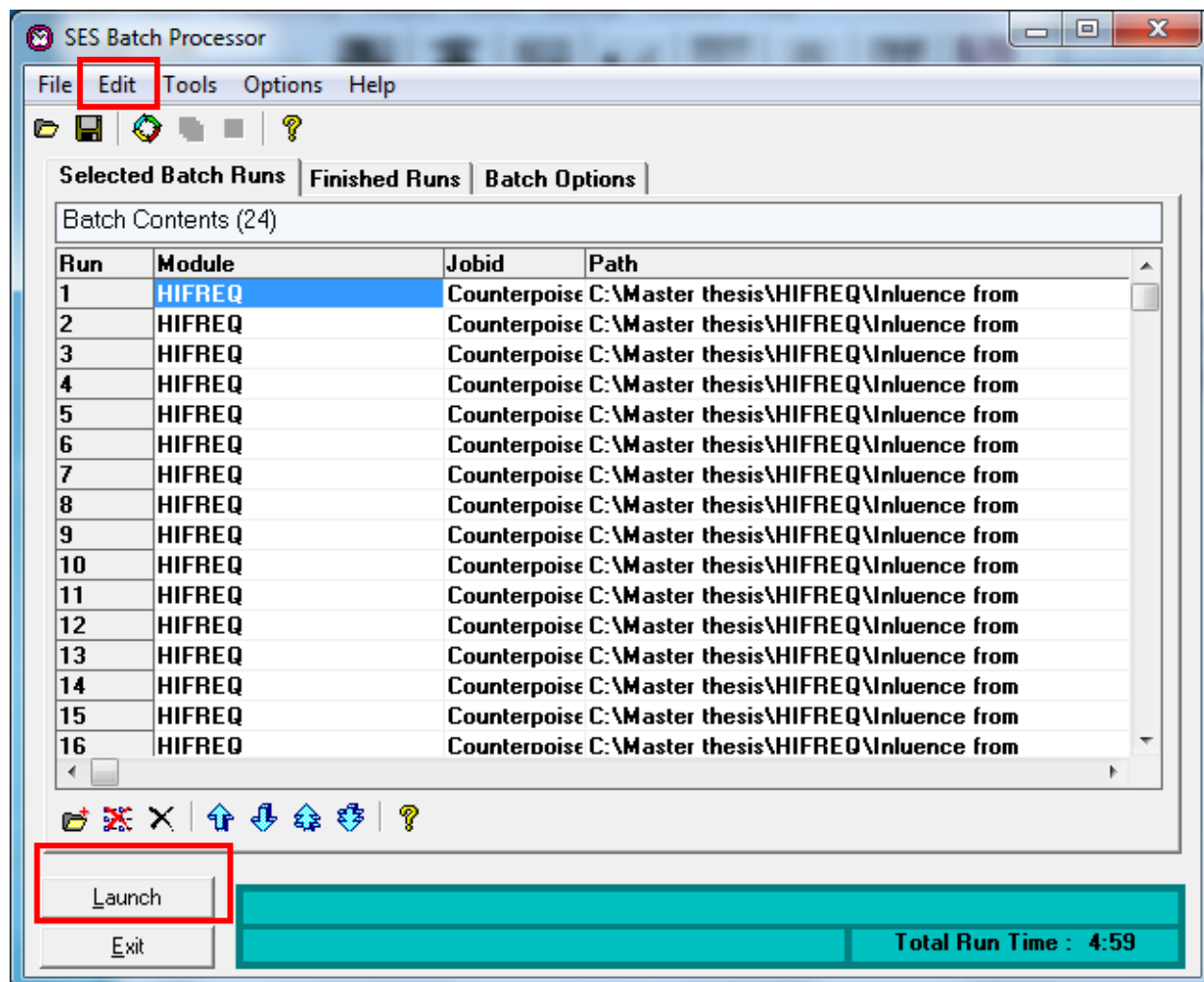
Under 'Filename Generation Options' one should change the file extension from .txt to .f05 in the 'Root Filename'-window, and define which parameter identifiers will be present in the file name.



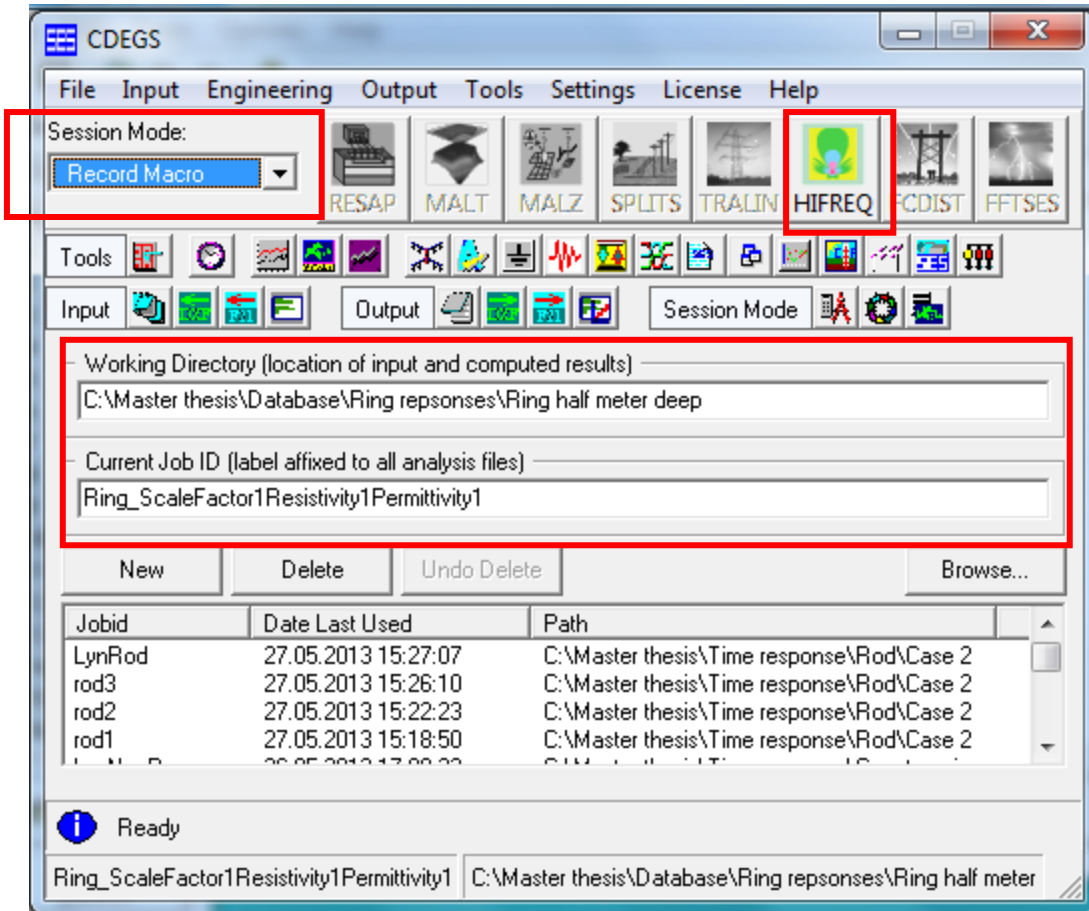
Parameters can also be entered in the main SESScript window, but in this case one should enter file names manually. Choosing 'Process' will generate the input files (.f05 files) for all possible parameter combinations.



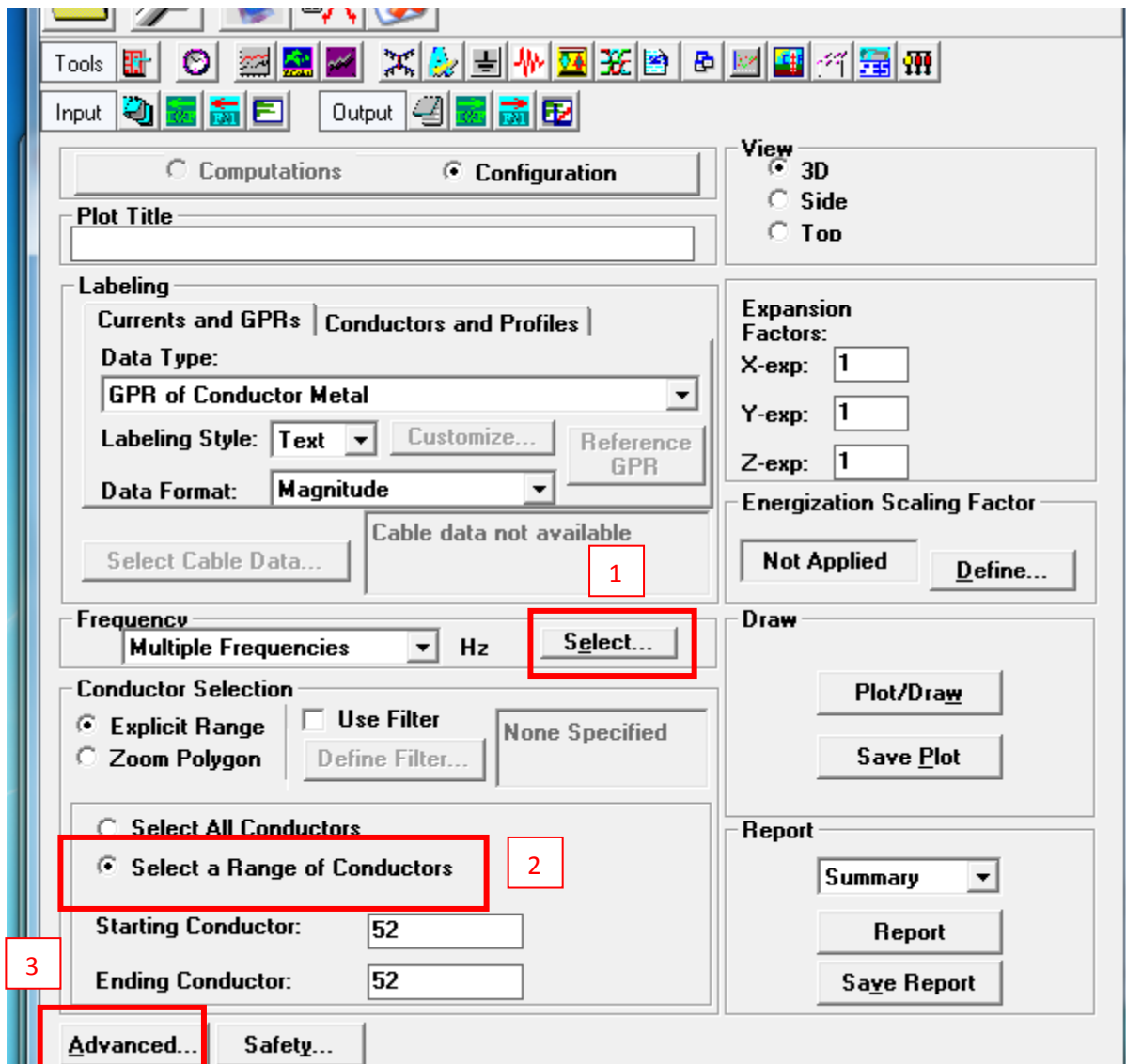
SESBat - tool is used to process multiple input files. One should choose Edit-Add Runs to add the files to be processed. Launch runs after the files have been uploaded.



SESBat can be used to examine/extract information from output files as well. For this purpose one should record a macro which contains all necessary steps. First one should choose JobID (for example one of the files that have been processed by SESBatch) for a case similar to those which are going to be examined. Choose 'Record Macro' in Session Mode and press HIFREQ button after that.

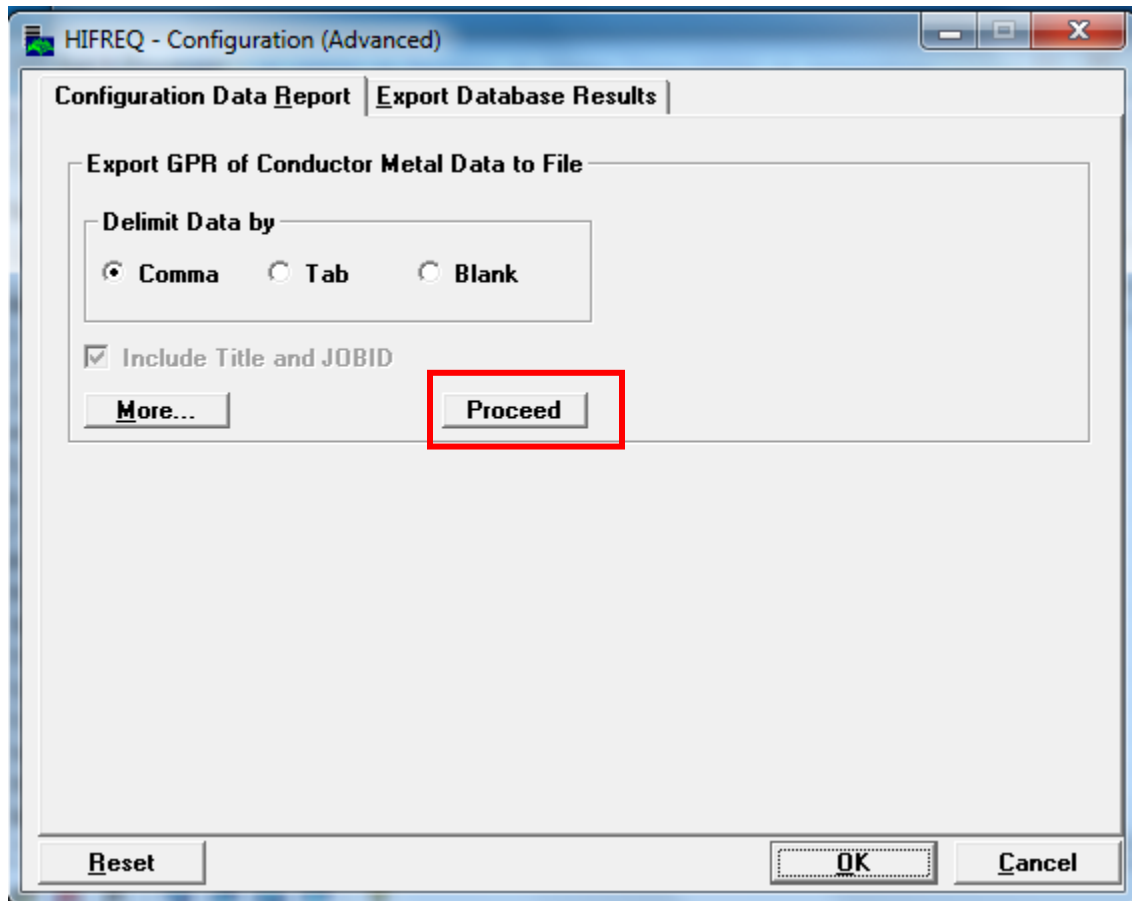


Press 'Select' - button for the frequency and choose 'Select all', 'Multiple Frequencies' will then appear in the frequency window. Choose 'Select a Range of Conductors' and enter the number of the energized conductor to extract GPR for the ground electrode. Press 'Advanced' after that.

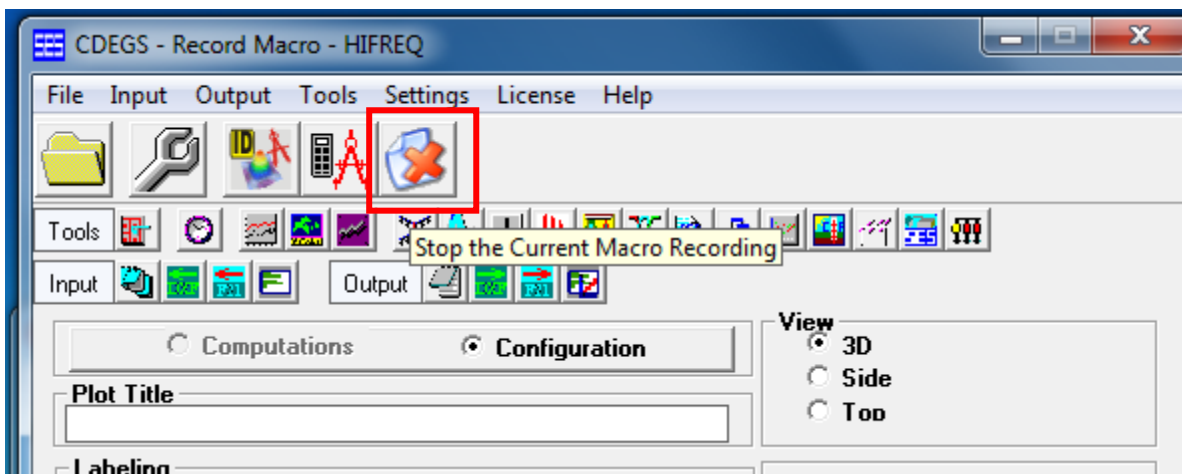




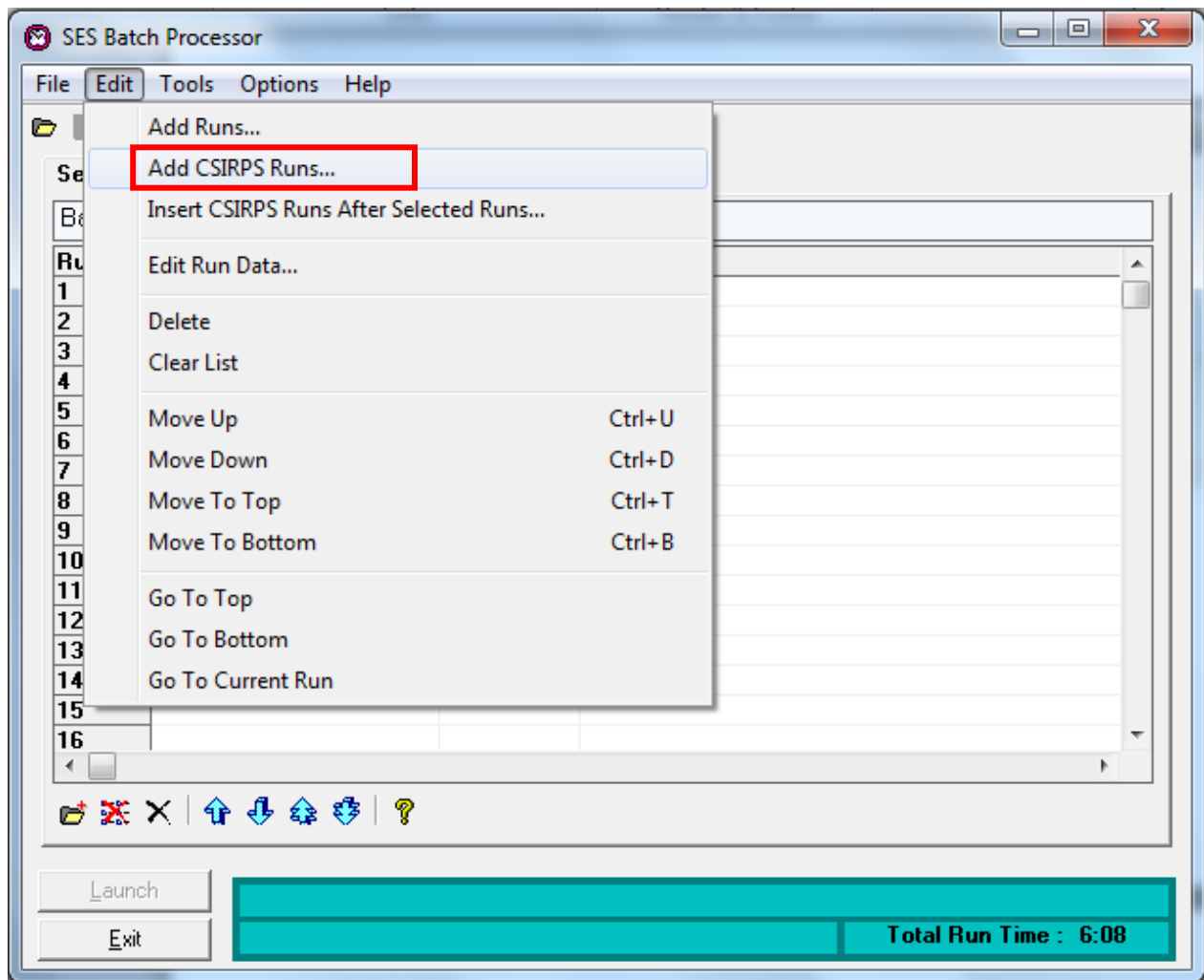
Press 'Proceed', create a folder named , for example, 'Reports' and save the file as a text file in the chosen directory.



Stop recording and save the macro.



To acquire text reports for multiple cases, choose first Edit- Add CSIRPS Runs and add the required macro. After that, add the output files (.f21 files) to be processed. Note that for different electrodes their own macros should be created.



## Appendix E

### Example of file used to extract and store necessary values in structure array

```
clear all;
str1='HI_Earthing_rod_';
str2='Length';
str4='Resistivity';
str6='Relative Permittivity'
str8='_Configuration_MetalGPR.txt';
N=5; % Order of approximation
Length = [1 2 3 4 5 6 7 8 9 10 15 20]; %Values or the length of the electrode
Resistivity= [100 300 500 1000 1500 2000 3000 4000 5000 10000 15000 20000
30000 50000]; %Soil resisitivity
Perm=[1 10 100]; %Values for relative permittivity
n3=length(Length); %Number of parameters used in the file names for the length
of the electrode
n2=length(Resistivity);% Number of parameters used in the file names
n1=length(Perm);
Ground.Rod.Data(n1,n2,n3).Y= zeros;% Admittance of the grounding system is
stored here for each combination of the parameters
Ground.Rod.Data(n1,n2,n3).Z= zeros;
Ground.Rod.Data(n1,n2,n3).W= zeros;
Ground.Rod.p1=Perm;
Ground.Rod.p2=Resistivity;
Ground.Rod.p3=Length;

%=====Create a database with obtained frequency responce=====
for a1=1:n1
for a2=1:n2
    for a3=1:n3
        str3=int2str(a3);%Make a string of integer for the number corresponding to
the length identifier in the file name
        str5=int2str(a2);%Resisitivity number
        str7=int2str(a1)% Make a string of an integer to use it for numbering the
files, permittivity
        Report = [str1 str2 str3 str4 str5 str6 str7 str8] ;%Defines which file to
be open by merging strings into on
        fil = fopen (Report); %opens the file
        n=0;
        f= zeros;
        w=zeros;
        z=zeros;
        r=zeros;
        x=zeros;
    while ~(feof(fil))
        line = fgetl (fil);
        pos= strfind (line,'RUNID : SAMPLE TEST RUN');
        if ~isempty(pos)
            n=n+1;
            if n <= 99
                f(n) = sscanf (line, '%*s %*s %*s %*s %*s %*s %*s %*s %*s %f');
            else
                f(n) = sscanf (line, '%*s %*s %*s %*s %*s %*s %*s %*s %*s %f');
            end;
        while ~(feof(fil))
```

```

    line = fgetl (fil);
    pos2= strfind (line,'2,');%Finds the line starting with the number of
conductor which GPR is reported
    if ~isempty(pos2)
        z(n) = sscanf (line, '%*s %*s %*s %*s %*s %*s %*s %*s %*s %*s %f');
        w(n) = sscanf (line, '%*s %*s %*s %*s %*s %*s %*s %*s %*s %*s %*s %f');
        r(n) = sscanf (line, '%*s %*s %*s %*s %*s %*s %*s %*s %*s %*s %*s %*s %f');
        x(n) = sscanf (line, '%*s %*s %*s %*s %*s %*s %*s %*s %*s %*s %*s %*s %*s %f');
        break;
    end
end
end
end

fclose(fil);
Ground.Rod.Data(a1,a2,a3).Z=z;% Impedance of the ground electrode
Ground.Rod.Data(a1,a2,a3).W=w;% Phase angle of the ground electrode
Ground.Rod.Data(a1,a2,a3).Y= 1./(r+1i*x);% Admittance as a function of
frequency for the ground electrode

end
end
end
Ground.Rod.s = f*1i*2*pi;
Ground.Rod.f=f;
save('Ground.mat', 'Ground')

```

## Appendix F

### Matlab source code for the function 'interfit'.

```
function [SER2] = interfit(type, P1,P2,P3,P4)%P1-relative permittivity, P2-
soil resistivity, P3-length/radius, P4-burial depth, P5-number of radials for
counterpoise grounding
% This function extracts response of an electrode with given parameters from
% structure array Ground.mat. For parameters between the points
% in the database , linear interpolation is used. As a second step the
% function calls vector fitting that creates a time-domain model from the
% frequency response of the defined ground electrode.

load Ground.mat
%=====Earth Rod=====
if type == 1

    f=Ground.Rod.f;
    nf=length(f);% Number of points with data values
    b1=length(Ground.Rod.p1);%number of permittivity values
    b2=length(Ground.Rod.p2);%number of resistivity values
    b3=length(Ground.Rod.p3); %number of length values
    minp1=Ground.Rod.p1(1);%The lowest value for parameters used in the
database
    minp2=Ground.Rod.p2(1);
    minp3=Ground.Rod.p3(1);
    maxp1=Ground.Rod.p1(b1);
    maxp2=Ground.Rod.p2(b2);
    maxp3=Ground.Rod.p3(b3);
    Ys(b1,b2,b3)=zeros;% Storage place for the values for a given point

    if P1 < minp1
        'The value is out of range. Minimum value for relative permittivity:',
minp1
    elseif P2< minp2
        'The value is out of range. Minimum value for soil resistivity:',
minp2
    elseif P3 < minp3
        'The value is out of range. Minimum value for length:', minp3
    elseif P1 > maxp1
        'The value is out of range. Maximum value for relative
permittivity:', maxp1
    elseif P2> maxp2
        'The value is out of range. Maximum value for soil
resisitivity:', maxp2
    elseif P3> maxp3
        'The value is out of range. Maximum value for
length:', maxp3
    else
        for pt=1:nf %For data points
            for c1=1:b1 %Permittivity parameter
                for c2=1:b2 % Resisitivity parameter
                    for c3=1:b3 % Length parameter
                        Ys(c1,c2,c3)= Ground.Rod.Data(c1,c2,c3).Y(pt);
                    end
                end
            end
        end
    end
end
```

```

        end
        Yi(pt)= interpn(Ground.Rod.p1,Ground.Rod.p2,Ground.Rod.p3,
squeeze(Ys),P1,P2,P3); % Creates a vector containing the value or each
parameter combination at a given frequency

        end
        figure (9)
        semilogx(abs(Ground.Rod.f), abs(Yi), 'Color', 'blue')
        xlabel 'Frequency [rad/sec]'
        ylabel 'Admittance (absolute value)'
        title 'Frequency Response of an Earth Rod'
        grid

        end
    end

%=====Counterpoise groudning with 4 radials=====
if type ==2
    f=Ground.Counterpoise.f;
    nf=length(f);% Number of points with data values
    b1=length(Ground.Counterpoise.p1);%number of permittivity values
    b2=length(Ground.Counterpoise.p2);%number of resistivity values
    b3=length(Ground.Counterpoise.p3); %number of length values
    b4=length(Ground.Counterpoise.p4);%number of depth parameters
    minp1=Ground.Counterpoise.p1(1);%The lowest value for parameters used
in the database
    minp2=Ground.Counterpoise.p2(1);
    minp3=Ground.Counterpoise.p3(1);
    minp4=Ground.Counterpoise.p4(1);
    maxp1=Ground.Counterpoise.p1(b1);%The highest value o the parameters
used in the database
    maxp2=Ground.Counterpoise.p2(b2);
    maxp3=Ground.Counterpoise.p3(b3);
    maxp4=Ground.Counterpoise.p4(b4);
    if P1 < minp1
        'The value is out of range. Minimum value for relative permittivity:',
minp1
    elseif P2< minp2
        'The value is out of range. Minimum value for soil resistivity:',
minp2
    elseif P3 < minp3
        'The value is out of range. Minimum value for length:', minp3
    elseif P4<minp4
        'The value is out of range. Minimum value for depth:', minp4
    elseif P1 > maxp1
        'The value is out of range. Maximum value for relative
permittivity:', maxp1
    elseif P2> maxp2
        'The value is out of range. Maximum value for soil
resisitivity:', maxp2
    elseif P3> maxp3
        'The value is out of range. Maximum value for
length:', maxp3
    elseif P4> maxp4

```

```

                                'The value is out of range. Maximum value for
depth:', maxp4
                                else

Ys(b1,b2)=zeros;% Storage place for the values for a given point
  for pt=1:nf %For data points
    for c1=1:b1 %Permittivity parameter
      for c2=1:b2 % Resistivity parameter
        for c3=1:b3 % Length parameter
          for c4=1:b4 %Depth parameter
Ys(c1,c2,c3,c4)= Ground.Counterpoise.Data(c1,c2,c3,c4).Y(pt);
          end
        end
      end
    end
  end

  Yi(pt)=
interp(Ground.Counterpoise.p1,Ground.Counterpoise.p2,Ground.Counterpoise.p3,G
round.Counterpoise.p4,squeeze(Ys),P1,P2,P3,P4); % Creates a vector containing
the value or each parameter combination at a given frequency

  end
  figure(10)
  semilogx(abs(Ground.Counterpoise.s), abs(Yi), 'Color', 'red')
  xlabel 'Frequency [rad/sec]'
  ylabel 'Admittance (absolute value)'
  title 'Frequency Response of a Counterpoise Electrode'
  grid

  end

end

%=====Ring Earthing=====
if type ==3
  f=Ground.Ring.f;
  nf=length(f);% Number of points with data values
  b1=length(Ground.Ring.p1);%number of permittivity values
  b2=length(Ground.Ring.p2);%number of resistivity values
  b3=length(Ground.Ring.p3); %number of length values
  b4=length(Ground.Ring.p4);%number of depth parameters
  minp1=Ground.Ring.p1(1);%The lowest value for parameters used in the
database
  minp2=Ground.Ring.p2(1);
  minp3=Ground.Ring.p3(1);
  minp4=Ground.Ring.p4(1);
  maxp1=Ground.Ring.p1(b1);
  maxp2=Ground.Ring.p2(b2);
  maxp3=Ground.Ring.p3(b3);
  maxp4=Ground.Ring.p4(b4);
  if P1 < minp1
minp1
    'The value is out of range. Minimum value for relative permittivity:',
    elseif P2< minp2
minp2
      'The value is out of range. Minimum value for soil resistivity:',
    elseif P3 < minp3

```

```

        'The value is out of range. Minimum value for radius:', minp3
elseif P4<minp4
        'The value is out of range. Minimum value for depth:', minp4
    elseif P1 > maxp1
        'The value is out of range. Maximum value for relative
permittivity:', maxp1
    elseif P2> maxp2
        'The value is out of range. Maximum value for soil
resisitivity:', maxp2
    elseif P3> maxp3
        'The value is out of range. Maximum value for
radius:', maxp3
    elseif P4> maxp4
        'The value is out of range. Maximum value for
depth:', maxp4
    else

Ys (b1,b2,b3,b4)=zeros;% Storage place for the values for a given point
    for pt=1:nf %For data points
        for c1=1:b1 %Permittivity parameter
            for c2=1:b2 % Resistivity parameter
                for c3=1:b3 % Radius parameter
                    for c4=1:b4 %Depth parameter
Ys (c1,c2,c3,c4)= Ground.Ring.Data (c1,c2,c3,c4) .Y (pt);
                    end
                end
            end
        end
    end

    Yi (pt)=
interpn (Ground.Ring.p1,Ground.Ring.p2,Ground.Ring.p3,Ground.Ring.p4,squeeze (Ys
),P1,P2,P3,P4); % Creates a vector containing the value or each parameter
combination at a given frequency

    end
    figure(12)
    semilogx(abs(Ground.Ring.s), abs(Yi), 'Color', 'red')
    xlabel 'Frequency [rad/sec]'
    ylabel 'Admittance (absolute value)'
    title 'Frequency Response of a Ring Electrode'
    grid
    end

end

%====Vector Fitting====%

dum(1,1,:)=Yi; % Admittance matrix, for matrix fitting it should be in 3D
g=dum;

s=Ground.Rod.s;
opts.N=5; %Order of approximation.
opts.poletype='logcmplx'; %Mix of linearly spaced and logarithmically spaced
poles
opts.weightparam=2; %5 --> weighting with inverse magnitude norm
opts.Niter1=4; %Number of iterations for fitting sum of elements (fast!)

```



```

opts.Niter2=4;      %Number of iterations for matrix fitting
opts.asymp=1;      %=2 --Fitting includes D
opts.logx=1;       %=0 --> Plotting is done using logarithmic abscissa axis
opts.relaxed=1;
opts.cmplx_ss=0; % A real only state space model is produced
poles=[];
clear VFdriver
[SER,rmserr,bigYfit,opts2]=VFdriver(g,s,poles,opts); %Creating state-space
model and pole-residue model

```

```

%=====
%=          Passivity Enforcement          =
%=====
clear opts;
opts3.parametertype='Y';
opts3.plot.s_pass=2*pi*i*linspace(0,2e5,1001).';
opts3.plot.ylim=[-2e-3 2e-3];

[SER2,bigYfit_passive,opts4]=RPdriver(SER,s,opts3);

%=====plot original and perturbed=====

%=====
s=2*pi*i*linspace(0,1e7,2001);Ns=length(s); %New frequency band
for k=1:Ns
    bigYfit(:, :, k)          =fitcalcPRE(s(k),SER.poles,SER.R,SER.D,SER.E);
    bigYfit_passive(:, :, k)=fitcalcPRE(s(k),SER2.poles,SER2.R,SER2.D,SER2.E);
end
figure(11),
Nc=length(SER.D);
for row=1:Nc
    for col=row:Nc
        dum1=squeeze(bigYfit(row,col,:));
        dum2=squeeze(bigYfit_passive(row,col,:));
        h1=semilogy(s/(2*pi*i),abs(dum1),'b'); hold on
        h2=semilogy(s/(2*pi*i),abs(dum2),'r--');
        h3=semilogy(s/(2*pi*i),abs(dum2-dum1),'g-');
    end
end
hold off
xlabel('Frequency [Hz]'); ylabel('Admittance [S]');
legend([h1 h2 h3], 'Original model', 'Perturbed model', 'Deviation');

end

```