



NTNU – Trondheim
Norwegian University of
Science and Technology

Multibooster performance validation

Christian Høy

Master of Energy and Environmental Engineering

Submission date: June 2013

Supervisor: Lars Erik Bakken, EPT

Norwegian University of Science and Technology
Department of Energy and Process Engineering

EPT-M-2013-57

MASTER THESIS

for

Stud.techn. Christian Høy

Spring 2013

Multibooster performance validation*Validering av ytelser for Multibooster***Background and objective**

Subsea boosting of hydrocarbon flow, either directly from the well or from a subsea separator, will typically result in the need of handling some free gas. Industry focus has lately turned to multiphase boosting where the technology need is steadily increasing. Aker Solutions, a company at the leading edge of technology in the field of subsea pump systems, is extending its product portfolio with two new pump technologies to improve production of gas rich fields through use of multiphase boosting.

Accurate prediction of booster performance is the main tool for estimation of return of investment as well as overall sizing of the production plant. Given the field requirements by the customer, the prediction tool shall also have the ability to provide suggestion to an optimal pump layout.

The following tasks are to be considered:

Emanating from literature study and existing test data at Aker Solutions, a prediction model shall be evaluated. Preparation for implementation of new model functionality can be done in existing in-house software's or using a commercial tool.

Focus areas

- In cooperation with Aker Solution conduct tests and document relevant performance test data.
- Evaluate existing performance model against experimental data. Especially this relates to high gas volume fractions.
- Document revised analytical models in order to improve the performance prediction tool.

” - ”

Within 14 days of receiving the written text on the master thesis, the candidate shall submit a research plan for his project to the department.

When the thesis is evaluated, emphasis is put on processing of the results, and that they are presented in tabular and/or graphic form in a clear manner, and that they are analyzed carefully.

The thesis should be formulated as a research report with summary both in English and Norwegian, conclusion, literature references, table of contents etc. During the preparation of the text, the candidate should make an effort to produce a well-structured and easily readable report. In order to ease the evaluation of the thesis, it is important that the cross-references are correct. In the making of the report, strong emphasis should be placed on both a thorough discussion of the results and an orderly presentation.

The candidate is requested to initiate and keep close contact with his/her academic supervisor(s) throughout the working period. The candidate must follow the rules and regulations of NTNU as well as passive directions given by the Department of Energy and Process Engineering.

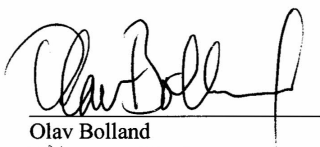
Risk assessment of the candidate's work shall be carried out according to the department's procedures. The risk assessment must be documented and included as part of the final report. Events related to the candidate's work adversely affecting the health, safety or security, must be documented and included as part of the final report. If the documentation on risk assessment represents a large number of pages, the full version is to be submitted electronically to the supervisor and an excerpt is included in the report.

Pursuant to "Regulations concerning the supplementary provisions to the technology study program/Master of Science" at NTNU §20, the Department reserves the permission to utilize all the results and data for teaching and research purposes as well as in future publications.


The final report is to be submitted digitally in DAIM. An executive summary of the thesis including title, student's name, supervisor's name, year, department name, and NTNU's logo and name, shall be submitted to the department as a separate pdf file. Based on an agreement with the supervisor, the final report and other material and documents may be given to the supervisor in digital format.

- Work to be done in lab (Water power lab, Fluids engineering lab, Thermal engineering lab)
 Field work

Department of Energy and Process Engineering, 14. January 2013



Olav Bolland
Department Head


Lars E. Bakken
Academic Supervisor

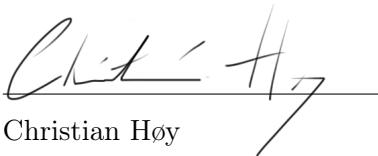
Co-Supervisors:

- Alberto Serena, NTNU/AKSO
- Audun Grunning, AKSO

Preface

This Master's thesis finalizes my Master of Science studies at Norwegian University of Science and Technology, Trondheim. The thesis has been really rewarding, and has given me insight into a very dynamic and innovative field of study.

I would like to thank my academic supervisor Lars Eirik Bakken for guiding me in the right direction and being available for questions and discussion. A special thanks to my assistant supervisor in Aker Solutions, Tarje Olderheim, for helpful guidance and driving me to and from Asker when I was visiting Tranby. Thanks to Tarjei Larsen for welcoming me to Tranby, and being available for questions and guidance on the pump testing, and a thanks to Christian Abellsson for helping me understand and develop the prediction model in MatLab.

A handwritten signature in black ink, appearing to read 'Christian Høy', written over a horizontal line. The signature is stylized and cursive.

Christian Høy

Trondheim, June 5, 2013.

Abstract

The move into producing oil and gas from deeper water, and the desire to increase recovery from ageing reservoirs, is driving the demand for subsea process and boosting systems. Aker Solutions is extending its product portfolio with two new pump technologies to improve production of gas rich fields through use of multiphase boosting. The MultiBooster is a multistage pump with semi-axial impellers, and is designed to handle a wide range of GVEs. This thesis has focused on the evaluation of a multiphase performance prediction tool with specific interest at high gas volume fractions.

Aker Solutions' current performance prediction model has been evaluated through a literature study. The gas tends to flow at a lower velocity than the liquid, causing drag between the phases and a performance degradation relative to single-phase operation. As more gas is introduced, gas bubbles will coalesce, causing separation of the fluids, and resulting in a higher degradation, instabilities, or even pump failure. Most of the performance prediction models for multiphase pumps found in the literature is of an empirical nature. These empirical models are only valid for the impeller designs and operating conditions in which they are based on, and fail when it comes to explaining the fundamental principles affecting the pump performance. It is believed that increased effort on computational fluid dynamics along with experiments and visualization will help to increase the knowledge in order to develop an accurate performance prediction model.

The current performance prediction model is also of an empirical nature, and many simplifications are made that are inaccurate as the gas volume fraction is increased. More research has to be done on thermodynamic modeling, equations of state, and viscosity modeling. The development of the input data such as the two-phase multipliers has been studied. The two-phase work and efficiency factor should be sorted for density ratio, gas volume fraction, as well as specific flow rate.

The HybridBooster was tested in order to map the performance of the semi-axial impellers, and verify the design of a gas tolerant radial impeller. Tests were conducted with single-phase and two-phase operation.

The HybridBooster performed well under various operating conditions and above the gas volume fraction target. The test loop was however the limitation and was not able to obtain various inlet density ratios.

Comparing the current performance prediction tool including input data from previous tests with the new tests showed that the input data needs to be updated. The system pressure should be varied in order to create two-phase multipliers at various density ratios. Single-stage tests does also have to be conducted in order to isolate the stage power consumption which is essential in the development of the two-phase efficiency factor.

Sammendrag

Industrien har rettet fokuset mot å produsere olje og gass fra dypere vann, samt og øke utvinningen fra eldre reservoarer. Dette driver etterspørselen etter undervannsprosessering. Aker Solutions utvider sin produktportefølje med to nye pumpeteknologier for å tilfredstille etterspørselen etter produkter for produksjon fra gassrike felt ved bruk av flerfase boosting. MultiBooster er en flertrinnspumpe med halvaksiale løpehjul, og er designet for å håndtere et bredt spekter av GVF. Denne oppgaven har fokusert på å evaluere et prediksjonsverktøy for flerfasepumping med spesiell interesse ved høye gassvolumfraksjoner.

Aker Solutions' nåværende prediksjonsmodell har blitt evaluert gjennom et litteraturstudie. Gassen har en tendens til å strømme med en lavere hastighet enn væsken, som forårsaker drag mellom fasene og en forringelse av ytelsen i forhold til enfasedrift. Hvis mer gass innføres, vil gassbobler koalitere, som igjen kan forårsake separering av fluidene, og resultere i en høyere degradering, ustabiliteter, eller til og med svikt i pumpen. De fleste prediksjonsmodellene for flerfasepumper funnet i litteraturen er av en empirisk natur. Disse empiriske modellene er bare gyldige for et spesifikt impellerdesign og ved driftsforholdet de er basert på, og svikter når det gjelder å forklare de grunnleggende prinsippene som påvirker pumpens ytelse. Det antas at økt innsats på numeriske strømningsberginger sammen med eksperimenter og visualisering vil bidra til å øke kunnskapen for å utvikle en nøyaktig ytelsesprediksjonsmodell.

Den nåværende prediksjonsmodellen er også av en empirisk natur, og mange av de forenklingene som er gjort er unøyaktige når gassvolumfraksjonen øker. Mer forskning må gjøres på termodynamisk modellering, tilstandslikninger, og viskositet modellering. Utviklingen av to-fase multiplikatorer, som fungerer som inndata til prediksjonsmodellen, har blitt studert. To-fase arbeid og virkningsgrad faktorene må sorteres for tetthetsforhold, gassvolumfraksjoner, samt for spesifikk volumstrøm.

HybridBooster ble testet for å kartlegge ytelsen til halvaksiale løpehjul, og verifisere designet av en gasstolerant radiell impeller. Tester ble utført ved en-fase og to-fase drift. HybridBoosteren viste gode resultater under ulike driftsforhold og over designkriteriet til gassvolumfraksjonen.

Testanlegget var imidlertid en begrensning og var ikke i stand til å oppnå ulike innløps tetthetsforhold.

Sammenligningen mellom prediksjonsmodellen med input data fra tidligere tester og de nye testene viste at input dataen må oppdateres. Trykket i systemet bør varieres for å skape to-fase multiplikatorer ved forskjellige tetthetsforhold. En ett-trinns test må utføres for å isolere akseffekten, som er en viktig paramter i utviklingen av tofase-virkningsgrad.

Contents

Preface	i
Abstract	iv
Sammendrag	vi
1 Introduction	1
1.1 Scope of thesis	2
1.2 Limitations	2
1.3 Tools used	2
1.4 Health, Security & Environment	2
1.5 Report structure	3
2 Multiphase flow	5
2.1 Two-phase definitions	5
2.2 Flow regimes	6
2.3 Multiphase modeling	7
2.4 Two-phase flow in pumps	8
3 The MultiBooster	11
3.1 MultiBooster	11
3.2 Pump theory	13
3.2.1 Performance data	14
3.2.2 Pumping viscous fluids	16
3.2.3 Dimensionless coefficients and model laws	17
3.3 Thermodynamics	19
4 Performance prediction model	21
4.1 General	21
4.2 Homogeneous Model	23
4.3 MIT-model	24
4.4 Other models	24
4.4.1 Computational fluid dynamics	26
5 Aker Solutions' performance prediction model	27
5.1 Simplifications and assumptions	27
5.1.1 Thermodynamics	28

5.1.2	Equation of State	29
5.1.3	Affinity and Similarity law	29
5.2	Two-Phase Multipliers	31
5.2.1	Revised two-phase multipliers	32
5.2.2	Sorting of the two-phase multiplier	37
5.3	Performance prediction	39
5.3.1	Two-phase viscosity	42
6	Prototype performance test	45
6.1	Experimental setup	46
6.1.1	Instrumentation	48
6.2	Experimental procedure	49
6.3	Experimental data	54
6.3.1	Test Mode 1	54
6.3.2	Test Mode 2	57
6.3.3	Test Mode 3	61
6.4	Suggestions to further work	64
7	Validation of existing performance model	65
7.1	Performance model	65
7.2	Validation	67
8	Conclusion	69
A	Equations	I
B	Two-phase work factor sorted for q^*	II
C	Test mode 2 results 3000 and 5000 rpm	III
D	Test mode 3 pump performance	IV

Nomenclature

Symbols

B	Empirical viscosity parameter	$[-]$
b	Impeller width	$[m]$
C	Absolute velocity	$[\frac{m}{s}]$
c	Speed of sound	$[\frac{m}{s}]$
D	Impeller diameter	$[m]$
d	Impeller diameter	$[m]$
F	Flow function	$[-]$
f	Correction factor	$[-]$
g	Gravity constant	$[\frac{m}{s^2}]$
H	Head	$[m]$
h	Enthalpy	$[\frac{J}{kg}]$
Ma	Mach number	$[-]$
MW	Molecular weight	$[\frac{kg}{kmol}]$
\dot{m}	Mass flow rate	$[\frac{kg}{s}]$
n	Rotational speed	$\frac{rev}{min}$
n_v	Polytropic volume exponent	$[-]$
P	Pressure	$[\frac{N}{m^2}]$
P	Power	$[W]$
Q	Volumetric flow rate	$[\frac{m^3}{s}]$
Re	Reynolds number	$[-]$
R_0	Gas constant	$[\frac{J}{kmolK}]$
R	Specific gas constant	$[\frac{J}{kgK}]$
T	Temperature	$[K]$
t	Time	$[s]$
U	Tangential velocity	$[\frac{m}{s}]$
V	Velocity	$[\frac{m}{s}]$
V	Volume	$[m^3]$
v	Specific volume	$[\frac{m^3}{kg}]$
x	Gas mass fraction	$[-]$
Z	Compressibility factor	$[-]$
z	Stage number	$[-]$

Greek symbols

α	Gas Volume Fraction	$[-]$
β	Impeller outlet angle	$[^\circ]$
η	Efficiency	$[-]$
κ_v	Isentropic volume exponent	$[-]$
μ	Dynamic viscosity	$[Pa \cdot s]$
Π	Head coefficient	$[-]$
π	Mathematical constant	$[-]$
ρ	Density	$[\frac{kg}{m^3}]$
φ	Flow coefficient	$[-]$
Ψ	Work coefficient	$[-]$
ω	Angular rotor velocity	$[\frac{rev}{s}]$

Subscripts

1	Inlet
2	Discharge
<i>g</i>	Gas
<i>l</i>	Liquid
<i>m</i>	Mixture
<i>m</i>	Model
<i>mp</i>	Multiphase
<i>P</i>	Prototype
<i>p</i>	Polytropic
<i>q</i>	Specific
<i>s</i>	Suction
<i>s</i>	Isentropic
<i>sp</i>	Single-phase
<i>SPL</i>	Single-phase liquid
<i>th</i>	Theoretical
<i>tot</i>	Total
<i>tp</i>	Two-phase
<i>u</i>	Useful
<i>v</i>	Viscous
<i>w</i>	Water
<i>x</i>	Circumferential direction
<i>z</i>	Radial direction

Abbreviations

AKSO	Aker Solutions
API	American Petroleum Institute
BEP	Best Efficiency Point
CFD	Computational Fluid Dynamics
const	Constant
DR	Density ratio
e.g	for example
et al.	and others
GLR	Gas Liquid Ratio
GMF	Gas Mass Fraction
GVF	Gas Volume Fraction
HI	Hydraulic Institute
HSE	Health, Security & Environment
ISO	International Organization for Standardization
JIP	Joint Industry Project
MIT	Massachusetts Institute of Technology
mod	Modified
NTNU	Norwegian University of Science and Technology
opt	Optimal
P&ID	Piping and instrumentation diagram
Ref	Reference
rpm	Revolutions Per Minute
TCV	Towards Closed Valve
TOV	Towards Open Valve

List of Figures

2.1	Flow regimes in a horizontal pipe [4]	6
3.1	Cross-sectional sketch of the MultiBooster	11
3.2	Typical single-stage pump [3]	13
3.3	Velocity triangles	14
3.4	Single-phase pump characteristics with specified losses	15
3.5	Effect of viscosity on performance characteristics [7]	17
4.1	Head degradation with free gas void ratio at 791 kPa for mixed pump K-70 [17]	22
4.2	Performance curves for the pump with the traditional method for the mixture density [13]	23
5.1	The two-phase work factor sorted for q^* at a given density ratio.	33
5.2	20% GVF multi-stage differential pressure predictions and test results [9].	34
5.3	Two-phase work factor for different rotational speed at 100% Q_{BEP}	35
5.4	Two-phase work factor for different rotational speed at 50% Q_{BEP}	36
5.5	A 2nd order polynomial fit for the two-phase multiplier at different q^* at DR=44.	37
5.6	Flow chart of the current performance prediction model.	41
6.1	Simplified P&ID for HybridBooster test stand	47
6.2	Test mode 1; single phase testing at constant speed TCV/TOV.	51
6.3	Test mode 2; two-phase testing at constant speed at different flow rates with varying GVF.	52
6.4	Test mode 3; two-phase testing towards open and closed discharge valve.	53
6.5	Single phase pump performance predictions along with test results for 3000, 4000, and 5000 <i>rpm</i>	55
6.6	Single phase stage performance at 4000 rpm	56
6.7	Single phase pump hysteresis TOV/TCV	57
6.8	Pump performance at 4000 <i>rpm</i> for different volume flow with varying GVF.	58
6.9	Stage 1 performance at 5000 <i>rpm</i> 120% Q_{BEP} with varying GVF.	59

6.10 Pump performance at 3000 *rpm* for different GVF with varying volume flow. 61

6.11 Pump efficiency at 3000 *rpm* for different GVF with varying flow. 62

6.12 Performance predictions vs. test results for 3000rpm with various GVFs. 63

List of Tables

5.1	A test matrix at a given DR and q^*	38
5.2	Correction factor for exponents x and y.	44
6.1	Pump prototype configuration	46
6.2	Instrumental uncertainties at guarantee point, ISO 9906 (+/-)	49
6.3	Experimental procedure divided into three stages	50

1 Introduction

The move into producing oil and gas from deeper water, and the desire to increase recovery from ageing reservoirs, is driving the demand for subsea process and boosting systems. Subsea means there are no surface facilities exposed to harsh weather or ice, which is critical in arctic regions and may decrease the environmental impact in the region. Many solutions have been developed, and boosting the untreated stream from the well to a remote processing facility is a concept where the multiphase pump plays a key role. Aker Solutions is extending its product portfolio with two new pump technologies to improve production of gas rich fields through use of multiphase boosting. The benefits of multiphase production are many. Multiphase pumps reduce the back pressure of the well in order to increase the daily production or extend the lifetime of a mature well. Installing a subsea production station instead of a platform also eliminates the need for offshore manning, helicopter transport, and offshore supply, which leads to lower costs and reduces the risk of accidents involving humans. It enables more cost-efficient developments, especially for long step-outs, marginal and dispersed fields, and in deeper waters.

Environmental benefits are also realized through the elimination of gas flaring, greatly reduced spill potential and a smaller footprint that reduces natural habitat disturbances. Associated natural gas is often a by-product of the oil extraction process and is often considered more of a nuisance than an economic resource. Many oil-production facilities flare and vent large volume of gas, and a multiphase pumps improves the possibility of zero gas flaring. The associated gas can then be transferred to a remote processing facilities. This does not only generate extra revenues for the operators, but also substantially reduce the greenhouse gas impact on the environment.

An accurate prediction of booster performance is of key importance for estimating the return of investment as well as the overall sizing of the production plant.

1.1 Scope of thesis

The main goal is to evaluate a prediction model developed by Aker Solutions through a literature study and test data.

This Master's thesis focuses on the following points:

- In cooperation with Aker Solutions conduct tests and document relevant performance data.
- Evaluate existing performance model against experimental data. Especially this relates to high gas volume fractions.
- Document revised analytical models in order to improve the performance prediction tool.

1.2 Limitations

The test procedures was planned by Aker Solutions, and was outside my jurisdiction. The testing of the multiphase pump at Aker Solutions was postponed through out the work of this thesis, and important test procedures has been further postponed. The test basis was therefore inadequate, and a full evaluation of the performance prediction model was not possible.

1.3 Tools used

The performance prediction tool is developed using MathWorks' MATLAB and is the main tool used in this Master's thesis. Microsoft Excel has been used to plot test data and performance predictions.

1.4 Health, Security & Environment

No risk assessment was necessary in this Master's thesis. However, a HSE-course through Aker Solutions eLearning system was conducted as I was taking part of testing at Aker Solutions test facility at Tranby.

1.5 Report structure

Chapter 2 serves to give a short introduction to multiphase flow and the key definitions will be given. In chapter 3 a general overview of the basic principles behind the MultiBooster and its characteristics is given. The theory from these chapters forms the basis for the understanding behind the results obtained from tests and predictions.

Chapter 4 presents different performance prediction models found through a literature study. In Chapter 5, the general theory behind the current performance prediction tool developed by Aker Solutions is introduced. The different simplifications will be discussed and suggestions to improvement will be given.

Chapter 6 describes the test procedure and documents the relevant test data.

In chapter 7 a discussion is given on what has to be done in order to validate the prediction model.

2 Multiphase flow

The MultiBooster will perform under various multiphase conditions, so a short review of multiphase flow and the flow regimes of interest will be given. A more detailed description of multiphase flow can be found in *Pipe Flow 2: Multi-phase Flow Assurance* by Bratland [4] .

The term multiphase flow is used to refer to any fluid flow consisting of more than one phase or component [5]. One of the most challenging aspects of dealing with multiphase flow is the fact that it can take many different forms [4]. Multiphase flow is a complex field of study and it is important to have knowledge about this field in order to accurately predict the flow in a multiphase pump. The type of flow is relevant for the inlet of a multiphase pump and can have an impact on performance. The different flow regimes will be introduced, with an emphasis on the flow regimes most likely to occur in a multiphase pump. Modeling multiphase flow becomes very complex, and simplifications must be utilized in order to make the calculations manageable. Most of the study on multiphase flow is done on pipe flow, and care has to be taken when utilizing models for rotating channel flow.

Only two-phase flow will be considered in this Master's thesis. Tests on HybridBooster are conducted with air and water as test fluid, while oil and gas may be evaluated for simulating the intended operating condition. The MultiBooster and HybridBooster will be introduced in section 3.1.

2.1 Two-phase definitions

Parameters commonly used are the gas volume fraction, from now on GVF, and gas mass fraction, from now on GMF. They are used to define the liquid content of the multiphase flow at actual conditions.

$$GVF \equiv \alpha = \frac{Q_g}{Q_g + Q_l} = \frac{x\rho_l}{x\rho_l + (1-x)\rho_g} \quad (2.1)$$

$$GMF \equiv x = \frac{\dot{m}_g}{\dot{m}_g + \dot{m}_l} = \frac{\alpha\rho_g}{\alpha\rho_g + (1-\alpha)\rho_l}. \quad (2.2)$$

Gas/Liquid ratio are also commonly used in the literature:

$$GLR \equiv \frac{Q_g}{Q_l} = \frac{\alpha}{1 - \alpha}. \quad (2.3)$$

Density ratio, ρ^* , is an important parameter in multiphase pumping performance, and is defined as:

$$\rho^* \equiv \frac{\rho_l}{\rho_g}. \quad (2.4)$$

Dependent on flow regime and flow geometry, the gas velocity may be different from the liquid velocity, and thus a "phase slip" between the two phases exists.

2.2 Flow regimes

Multiphase flow can be divided into two general topologies, namely dispersed flows and separated flows, which again can be divided into different flow regimes. Figure 2.1 shows the different flow regimes that might occur in a horizontal pipe.

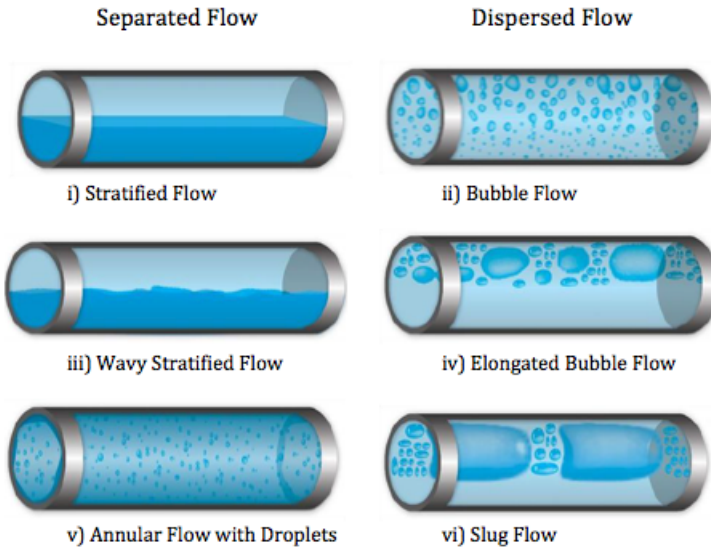


Figure 2.1: Flow regimes in a horizontal pipe [4]

As the MultiBooster are designed for handling a large specter of GVFs, the pump may face several flow regimes. The types of flow regime is relevant for the inlet to a two-phase pump and can have an impact on performance. Handling mixtures with high fractions of gas by centrifugal pumps is a difficult task since gas and liquid tend to separate because of the large density difference. Pumping can then become very inefficient or even impossible [7]. This will be discussed in more detail in section 2.4.

What kind of regime you have depends on the phase velocities. How and when the different regimes occur is described in detail in *Pipe Flow 2: Multi-phase Flow Assurance* by Bratland [4]. This theory is relevant in determining the flow regime in the piping upstream, thus the pump inlet, and downstream of the pump. The flow regimes are also relevant for rotating flow channels, but rotating effects such as Coriolis force and centrifugal forces play a key role in determining the flow regime. Homogeneous bubbly flow is the preferred flow regime in multiphase pumps, because it is the flow regime least likely to separate. As the GVF is increased, bubbles tends to coalesce, and slug flow or even wavy stratified flow may be expected. For this reason, multiphase pumps are sometimes equipped with a mixer at the pump inlet in order to break up any flow regime, and develop a dispersed flow regime as close to a bubbly flow as possible.

2.3 Multiphase modeling

Multiphase flow can be modeled in order to give an indication of the flow behavior. Computational fluid dynamics is a tool frequently used by the industry for pre-design and prediction purposes. For single-phase flow a set of mass, momentum, and energy conservation equations are sufficient in describing the flow behavior. However, for multiphase flow a set of mass, momentum, and energy equations for each phase is needed to describe the main conservation principles governing transient flow. In practice, simplifications are made to make the calculations more manageable. There are many ways to model multiphase flow. What type of model to use depends on the flow regime of interest. When the GVF is low, a mixer at the pump inlet develops a bubbly flow regime. Gas bubbles are traveling along with the liquid flow, the fluids can be considered

as one, and a homogeneous model can be used. As the amount of gas increases, the two phases tend to separate and the multiphase flow can be modeled using a two-fluid model.

The mixture model

For relatively low GVF, bubbles will move along with the liquid phase, creating a bubbly flow. The mixture model solves for the mixture momentum equation and prescribes relative velocities to describe the dispersed phases. The mixture model can also be used without relative velocities for the dispersed phases to model homogeneous multiphase flow. The mixture density is given by:

$$\rho_m = (1 - \alpha)\rho_l + \alpha\rho_g \quad (2.5)$$

The homogeneous model

The homogeneous model assumes a uniform mixture of liquid and gas phase where all fluids share the same velocity field, as well as other relevant fields such as temperature, turbulence, etc.

The two-fluid model

As the gas fraction gets significant, the flow can no longer be considered as one, and the two-phase flow can be modeled with the two-fluid model. The separated fluids are calculated with a momentum equation for each phase.

2.4 Two-phase flow in pumps

The centrifugal pump has a good performance for incompressible fluids, but its performance suffers when compressible gas is introduced. Several challenges occur when pumping a two-phase mixture. The capability of a centrifugal pump to convey a two-phase mixture depends on whether gas and liquid form a homogenous mixture or to what extent the two phases separate [7]. The geometry and body forces in a pump are different from

a flow through a straight pipe, but the same physical aspects are effective in determining the flow patterns which, in turn, have an impact on the energy transfer. Conventional centrifugal pump design can be used for low GVF, but faces problems at GVFs in the range of 3 - 10% , so design modifications are required.

The pressure field in a rotating impeller strongly affect the phase distribution along with body forces such as the Coriolis force, centrifugal forces, and buoyancy effects. The Coriolis force transports the liquid to the pressure surface of the impeller blade, while the buoyancy effect move the gas bubble towards the location of the lowest pressure, namely the suction surface of the impeller blades. Both these effects amplifies the phase separation and reduces the gas handling capability of the radial impeller. The MultiBooster consists of semi-axial, or mixed-flow, impellers, because centrifugal and Coriolis accelerations have opposing components, thus reducing the tendency of phase separation.

The fundamental principles that affect the multiphase pump performance are:

- Bubble size
- Density ratio
- Flow regime
- Gas content
- Reynolds number
- Speed of sound
- Viscosity

Bubbles entrained by liquid flow and droplets of liquid carried by a gas stream can be represented by the homogenous flow model. However, there is some slip between the phases which causes additional losses. As the GVF is increased, bubbles tend to coalesce and form larger gas accumulations, causing the pump delivery to be disrupted, the head breaks down and the pump becomes "gas-locked". Gas accumulation leads to instabilities in the pump operation. The liquid flow will accelerate due to the decreased flow area caused by a gas pocket, and as the liquid ve-

locity rises, the gas may be swept away with the liquid flow. This cycle may repeat itself, and a periodic variation in head and flow rate may be the consequence. Gas-locking is a phenomenon where accumulated gas blocks the impeller passage and the pump is not able to deliver any head. These effects occurs particularly outside the best efficiency point and at low volumetric flow rates. Aker Solutions has solved this by including an internal mixing in the impeller, causing leakage from pressure side to suction side, in order to apply mixing and prevent flow separation and gas-locking.

The speed of sound changes noticeably for variations in GVF. Over a wide range of GVFs, the speed of sound of a mixture is much lower than the speed of sound of each medium alone. This is due to the compressibility effect of gas on the liquid. For fluid velocities at speed of sound, density changes becomes significant and the flow is termed compressible [8]. The Mach number is often used in this regard, and is defined as:

$$Ma = \frac{u}{c}. \quad (2.6)$$

As the Mach number increase the overall level of losses increases.

An increased density ratio has an effect on phase separation. A high density difference between the phases increases the possibility of phase separation. The system pressure and the molecular weight of the gas are factors that determines the density ratio. Also as the density ratio decreases, the fluid densities will become similar and the phase separation effect will be smaller and the tendency of phase separation diminishes.

The Reynolds number gives a measure of the ratio between the inertial forces and the viscous forces, and is an important parameter when determining the viscous effect on multiphase pumping. As the oil viscosity increases, the drag of a bubble rises and the occurrence of separation is decreased. This will prevent gas-locking, but the friction will become larger and the performance will drop. Ramberg [14] concluded in his study that the head, flow, and efficiency are affected by the liquid viscosity, and that the variation in Reynolds number impacts the efficiency especially.

3 The MultiBooster

In order to fully understand the MultiBooster performance model, it is necessary to know the general theory behind centrifugal and semi-axial pumps, design requirements, and performance parameters. A short review of the general theory behind centrifugal pumps, some design requirements, and performance parameters will be given in this chapter. The same theory apply for semi-axial impellers. A more detailed description of centrifugal and semi-axial pumps can be found in *Centrifugal Pumps* by Gülich [7].

Handling two-phase flow impair new challenges compared with single-phase operation. The next sections will introduce the basic principles in single-phase pumping, and present some of the challenges met in two-phase pumping. The fundamental principles behind two-phase flow was given in chapter 2.

3.1 MultiBooster

The MultiBooster is a subsea pump developed by Aker Solutions to handle various inlet conditions of multiphase flow. The MultiBooster is a multistage pump with semi-axial impellers, due to its capability of handling higher GVFs. To allow the MultiBooster pump to handle high GVFs, up to 100%, the pump contains purpose-designed semi-axial impellers with an internal mixing feature. A cross-sectional drawing of the MultiBooster is shown in figure 3.1.

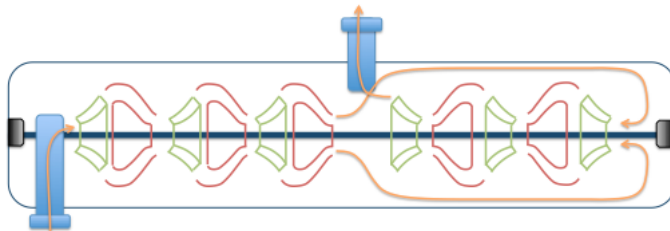


Figure 3.1: Cross-sectional sketch of the MultiBooster

As the stream from the well normally changes over the production life of a field, high performance over a wide range of GVFs and inlet fluid conditions are desirable. Some of the challenges met during two-phase pumping, specially towards higher gas volume fractions, are:

- The fluids tendency to separate causing instabilities or even pump failure.
- Increased heat generation.
- Axial thrust force and its variation from 0 to 100% GVF. This is a major challenge when it comes to impeller balancing.
- Increased seal leakage.

In this thesis, tests were conducted on Aker Solutions' HybridBooster. The HybridBooster is similar to the MultiBooster, but are designed to handle lower GVFs and uses both semi-axial impellers as well as gas tolerant radial impellers. The test configuration and test procedure are explained in chapter 6.

3.2 Pump theory

Centrifugal pumps are a type of turbomachinery used for transporting liquids by raising a specified volume flow to a specified pressure level. This is done by the conversion of the rotational kinetic energy to the hydrodynamic energy of the fluid flow. Figure 3.2 show a single-stage pump composed of a casing, a bearing housing, the pump shaft, and an impeller. The impeller transfers the energy necessary to transport the fluid and accelerates it in the circumferential direction, hence the static pressure increases due to kinetics. The fluid exiting the impeller is decelerated in the volute and the following diffuser, thus increasing the static pressure.

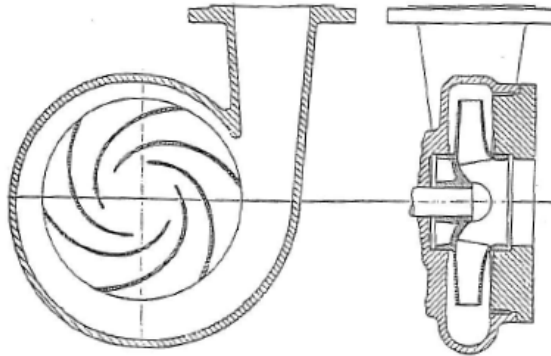


Figure 3.2: Typical single-stage pump [3]

The centrifugal pump is a robust concept that is able to deliver high head and reasonable flow rates with excellent efficiency.

The MultiBooster has multiple semi-axial stages with each impeller stage tailored to the actual stage conditions. As the flow moves it way through the pump, the gas will be compressed, inducing a lower gas volume fractions, hence a lower volumetric flow rate for the latter stages.

3.2.1 Performance data

All work done on the fluid takes place in the impeller. Therefore, the energy absorbed by the pump will be determined by the conditions of the fluid at the inlet and outlet of the impeller. Figure 3.3 shows the velocity triangles for the outlet on the left and for the inlet on the right.

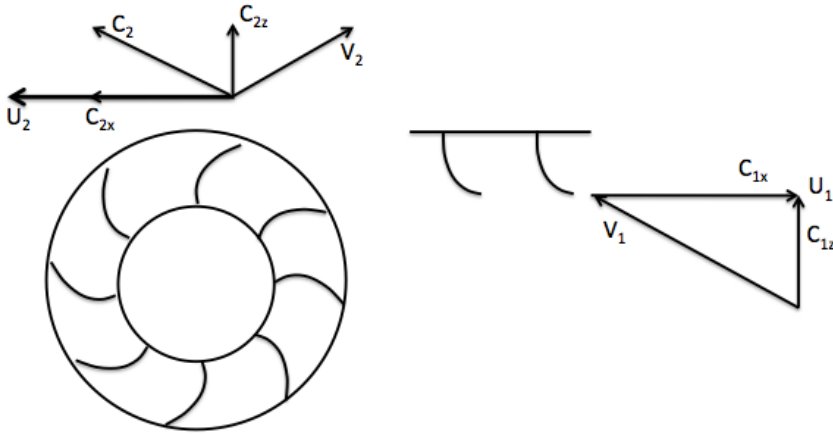


Figure 3.3: Velocity triangles

It is common to use head as the pressure parameter in centrifugal pumps. Head, or the vertical lift, is dependent on the outlet and inlet velocities and is not dependent on the density of the medium pumped. With figure 3.3 in mind, the fundamental single-phase centrifugal pump equation which links the head and impeller velocities can be written as:

$$H_{th} = \frac{\Delta P}{\rho g} = \frac{u_2 c_{2x} - u_1 c_{1x}}{g} \quad (3.1)$$

The pump theoretical capacity is the product of the radial component of the absolute velocity and the outlet area:

$$Q_{th} = \pi D_2 b_2 c_{2z} \quad (3.2)$$

These two parameters forms the single-phase pump characteristics. Figure 3.4 shows how different losses reduce the head, and shape the actual head curve.

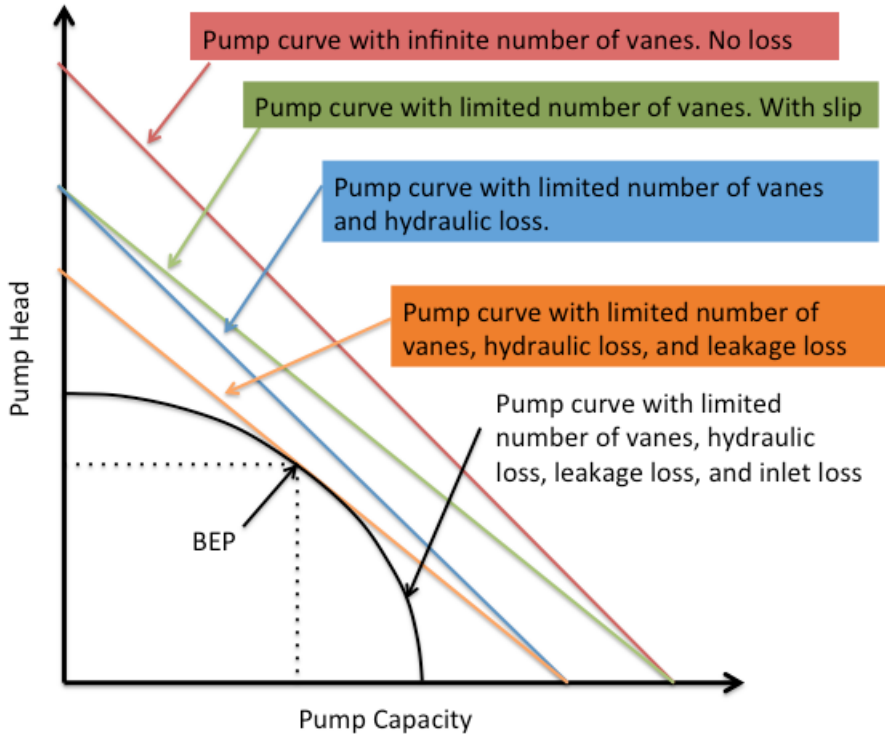


Figure 3.4: Single-phase pump characteristics with specified losses

When the flow rate of a pump varies, the head, the power consumption, and the efficiency change too. At a certain flow rate the pump efficiency has a maximum value called the "best efficiency point", BEP.

Hydraulic losses in a pump are generated through friction and vortex dissipation. Both skin friction and non-uniform flow contributes to increased hydraulic losses. Leakage is a volumetric loss and is caused by leakage through the annular seal at impeller inlet or through devices such as for axial thrust balancing. As multiphase flow is introduced to the pump, additional losses impair the pump performance. Velocity difference, slip,

between the phases, fluid separation, and speed of sound, is important multiphase effects that reduces the pump performance. These effects were discussed in section 2.4. These losses affect the pump characteristics and makes the useful power P_u smaller than the power supplied to the pump shaft.

The useful power P_u of a pump is obtained by:

$$P_u = \rho g H Q \quad (3.3)$$

The power P needed at the coupling is greater than the useful power because of all the losses of the pump. The pump efficiency becomes:

$$\eta = \frac{P_u}{P} \quad (3.4)$$

3.2.2 Pumping viscous fluids

The industry is currently moving towards pumping fluids of higher viscosity. When pumps are tested, they are usually tested with water. Pumping fluids with a viscosity higher than water, result in additional losses and the pump performance changes. Correction factors for highly viscous fluids are applied in order to determine the pump characteristics.

$$f_Q = \frac{Q_v}{Q_w} \quad f_H = \frac{H_v}{H_w} \quad f_\eta = \frac{\eta_v}{\eta_w} \quad (3.5)$$

The performance data and pump characteristics are determined either by empirical methods or loss analysis. These correction factors are also important in determining the liquid contribution in multiphase flow. In general, the correction factor depends on the Reynolds number, the specific speed, and the flow rate q^* ,

$$f_x = f(Re, n_q, q^*) = f(n, Q, H, d_2, q^*, v).$$

Figure 3.5 shows in principle how head and efficiency are changed from service with water to operation with a viscous fluid.

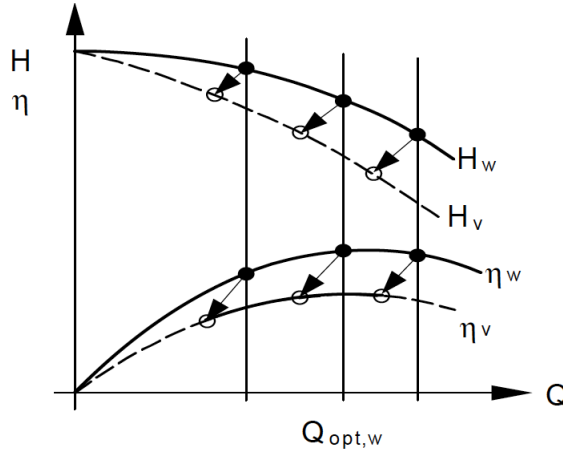


Figure 3.5: Effect of viscosity on performance characteristics [7]

When sufficient geometrical data of the pump are available, a loss analysis yield the most accurate results. The loss analysis is given in detail in *Centrifugal Pumps* by Gülich [7]. If an exact loss analysis is not required, correction factors and empirical correlations can be used to convert the performance characteristics for water into those relevant for viscous fluids.

3.2.3 Dimensionless coefficients and model laws

Turbulent flows in complex geometries cannot be described accurately by simple analytical means. Instead, flows may be treated with similarity characteristics and dimensionless coefficients by means of which test results can be generalized and then applied for prediction purposes in new applications [7]. Usually, a model pump ("m") is tested, the pump characteristics are developed, and the similarity or affinity law are applied to predict the performance of a prototype pump ("p") at different speeds and/or sizes.

$$Q_p = Q_m \left(\frac{n_p}{n_m} \right) \left(\frac{d_p}{d_m} \right)^x \quad (3.6)$$

$$H_p = H_m \left(\frac{n_p}{n_m} \right)^2 \left(\frac{d_p}{d_m} \right)^y \quad (3.7)$$

$$P_p = P_m \left(\frac{n_p}{n_m} \right)^3 \left(\frac{d_p}{d_m} \right)^z \quad (3.8)$$

where $[x,y,z] = [1,2,3]$ and $[x,y,z] = [3,2,5]$ for the affinity law and similarity law, respectively. The affinity law are applied when only d_2 is changed, and the similarity law is applied when all dimensions are changed relative to the model using a scaling factor. These laws can be applied when the hydraulic efficiency is constant.

To generalize the head and flow parameters, two dimensionless numbers are created. These are the head and flow coefficients, respectively:

$$\Pi = \frac{H_t}{u_2^2/2g} \quad (3.9)$$

$$\varphi = \frac{c_{m2}}{u_2} = \frac{Q}{\pi d_2 b_2 u_2} \quad (3.10)$$

where b_2 is the axial width of the impeller outlet. These can be derived from the velocity triangles, which are made dimensionless by dividing the velocities with the circumferential velocity. $\Pi=f(\varphi)$ is a dimensionless characteristic which is independent of speed and impeller diameter. A dimensionless number often used in the literature is q^* and is defined as the flow rate relative to the flow rate at the best efficiency point:

$$q^* = \frac{Q}{Q_{BEP}}. \quad (3.11)$$

3.3 Thermodynamics

Performance calculations on turbomachinery requires the use of thermodynamics. As the fluid is flowing through the pump, friction and mechanical losses will cause the fluid to increase in temperature. Also, as gas is introduced, the compression of gas leads to a temperature increase. However, a simplification can be made, in which the pumping process is viewed as isothermal. If phase slip is neglected, the head of the two-phase mixture becomes:

$$H_{tot} = (1 - x) \frac{p_2 - p_1}{g\rho_l} + x \frac{Z_1 R_0 T}{MWg} \ln \frac{p_2}{p_1} \quad (3.12)$$

As the two-phase mixture reaches a gas dominated mixture, the temperature increase during the compression can not be neglected, and the real gas behavior has to be taken into consideration. The real gas behavior is well documented by Schultz [15]. The polytropic head is an expression of how much work is required to obtain a given pressure ratio, and is for dry gas defined as;

$$H_P = f \frac{n_v}{n_v - 1} \frac{Z_1 R_0 T_1}{MWg} \left[\left(\frac{p_2}{p_1} \right)^{\frac{n_v - 1}{n_v}} - 1 \right], \quad (3.13)$$

where f is a correction factor taking the variation in n_v into consideration.

$$f = \frac{h_{2s} - h_1}{\frac{\kappa_v}{\kappa_v - 1}} [p_2 v_2 - p_1 v_1], \quad (3.14)$$

and the isentropic and polytropic exponent, κ_v and n_v , respectively, are defined as

$$\kappa_v = - \frac{d(\ln p)}{d(\ln v)} = - \frac{v}{p} \left(\frac{\partial p}{\partial v} \right)_s, \quad (3.15)$$

$$n_v = - \frac{d(\ln p)}{d(\ln v)} = - \frac{v}{p} \left(\frac{\partial p}{\partial v} \right)_{\eta_p}. \quad (3.16)$$

The total head for the multiphase mixture then becomes:

$$H_{tot} = (1 - x) \frac{p_2 - p_1}{g\rho_l} + xf \frac{n_v}{n_v - 1} \frac{Z_1 R_0 T_1}{MWg} \left[\left(\frac{p_2}{p_1} \right)^{\frac{n_v - 1}{n_v}} - 1 \right], \quad (3.17)$$

where phase exchange and phase slip is neglected.

4 Performance prediction model

Performance prediction of centrifugal pumps on liquids is well established, the performance prediction of these pumps on multiphase mixtures, however, presents a challenge. Multiphase flow behavior prediction for centrifugal pumps is a difficult task due to the flow complexity involved inside turbomachinery. Few studies are available regarding the behavior of centrifugal pumps handling two-phase mixtures. Most of the petroleum industry's research has been of an empirical nature because of the complexity of the phenomena that rule the centrifugal behavior [13]. This section includes a literature review of the different models for predicting pump performance under two-phase flow. As the main objective of a pump is to increase the pressure, authors show most concern with head degradation than other performance parameters. The power consumption needs to be predicted in order to develop the efficiency parameter. Some authors have developed empirical correlations to predict the head curves of experimental tested pumps, and can not be used directly for prediction purposes on Aker Solutions' pumps. They might however give valuable insight into multiphase prediction modeling and is therefore included in this thesis. Chapter 5 will introduce the performance prediction model currently used by Aker Solutions.

4.1 General

Zhou et al. [17] states that the degradation in two-phase flow occurs when the gas tends to flow at a much lower velocity than the liquid, which has been confirmed by photographic studies in the nuclear industry. These studies also observed that the gas in a bubbly flow tends to dampen the acceleration of liquid phase in the impeller. As the gas is further increased, the bubble flow turns into a separated slug flow where the liquid phase is accelerated more, causing higher degradation. Zhou et al. [17] present figure 4.1 to show the behavior of a mixed flow pump with a constant intake pressure at various inlet GVFs. The figure shows that higher GVF at the pump inlet causes higher head degradation.

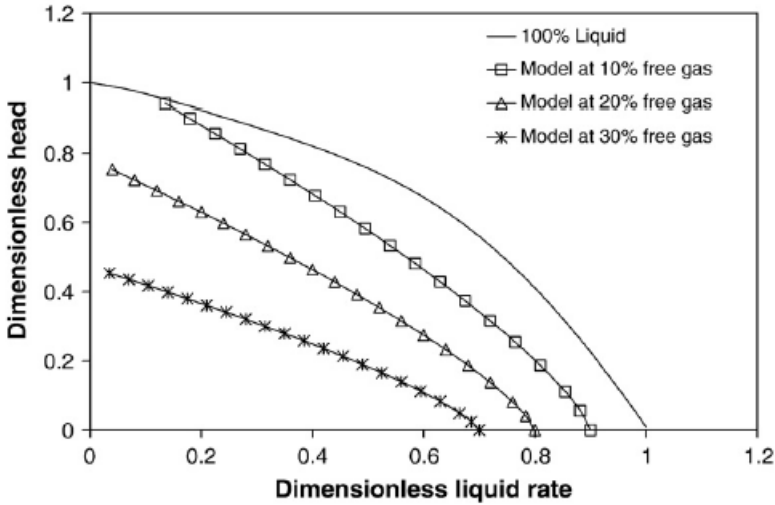


Figure 4.1: Head degradation with free gas void ratio at 791 kPa for mixed pump K-70 [17]

Lea et al. [12] tested three different pumps with a two-phase mixture. The tests were conducted by increasing the GVF at the pump inlet in steps until the pump failed to deliver any head. The tests gave valuable insight on two-phase pump performance, but no models were presented by the authors. Some of the conclusions from their study was:

- For a constant gas fraction at the pump inlet, head degradation decreases as the intake pressure increases.
- Mixed flow impellers handled gaseous fluids better than radial impellers.
- The affinity laws could not be applied to the pump under two-phase flow conditions.

Cirilo [6] studied the effect of varying the number of stages in the pump under two-phase operation. His results showed a trend of less head degradation on the pumps with more stages. This is because of the lower GVF and hence lower flow rates for the later stages, thus developing a higher head.

4.2 Homogeneous Model

The homogeneous model assumes that single-phase performance curves can be used to represent two-phase behavior [13]. The two-phase flow head is calculated as if it was single-phase liquid at the mixture's total flow rate. The mixture density is calculated by:

$$\rho_m = (1 - \alpha)\rho_l + \alpha\rho_g \quad (4.1)$$

Once the head developed is determined, the stage discharge pressure can be calculated. The GVF and total volumetric flow rate are adjusted to the new condition, and the procedure can be applied to the next stage. It is then possible to develop performance curves at different GVFs as shown in figure 4.2. This method does not implement any head degradation, rather it shifts the head points from the single-phase water curve according to the total volumetric flow rate.

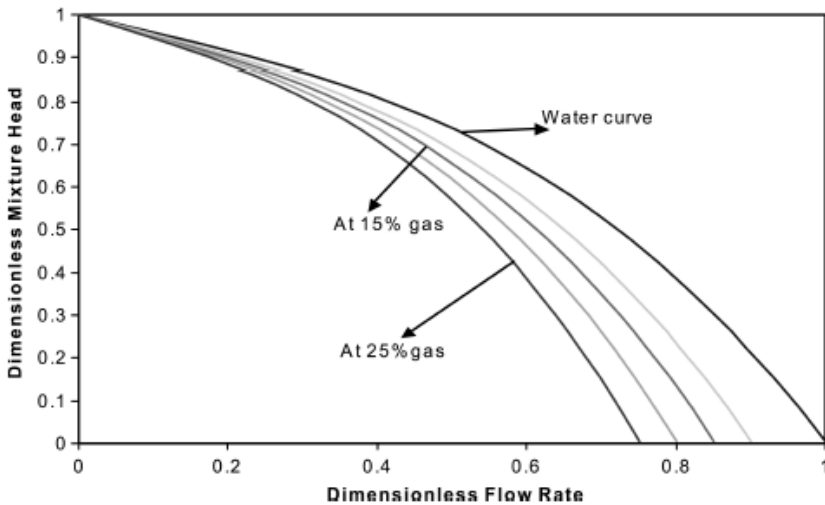


Figure 4.2: Performance curves for the pump with the traditional method for the mixture density [13]

The homogeneous method makes it possible to predict the head performance when the flow is treated as a homogeneous mixture, however,

experimental studies are crucial when predicting surge, choking, and gas-locking. As the GVF is increased the flow can no longer be treated as a homogeneous mixture, and the homogeneous method should no longer be used. In general, the homogeneous model should be avoided except at very high inlet pressures and very low GVF.

4.3 MIT-model

Korenchan [11] applied an analytical/semi-empirical model developed by J. Mikielwicz and D.G. Wilson [16] at MIT to correlate centrifugal pump performance in two-phase flow to experimental water-steam data on a nuclear reactor pump system. The MIT-model focuses on the calculation of the head-loss ratio which relates experimental head characteristics with ideal single- and two-phase performance. The head-loss ratio, H^* , is defined as the two-phase head losses to the single-phase head losses at the same flow coefficient:

$$H^* \equiv \frac{\Pi_{tp,th} - \Pi_{tp}}{\Pi_{sp,th} - \Pi_{sp}} \quad (4.2)$$

The two-phase flow equation can be written as:

$$\Pi_{tp} = 1 - \frac{F_{tp2}\varphi_{tp2}}{\tan\beta_2} \quad (4.3)$$

Wilson et al. [16] states that by normalizing two-phase head losses to single-phase losses, as opposed to normalizing the two-phase head to the single-phase head, theoretical performance has been introduced along with empirical performance. It is therefore anticipated that the two-phase performance dependence on a particular pump geometry is diminished.

The challenge with this method is to determine the slip factor necessary to calculate the relative flow angle at the impeller outlet, β_2 .

4.4 Other models

Zhou et al. [17] summarizes different empirical studies to predict two-phase pump performance. The empirical models use the degradation

principle in order to predict the multiphase performance. They are based on test data from impellers with a specific hydraulic design and size, and a set of empirical coefficients are created. These empirical models are only valid for the impeller designs and operating conditions in which they are based on, and come in short of explaining the fundamental principles behind multiphase pumping. It is therefore of interest to take a step back and start off with the basic principles involved in multiphase pumping, and generate a general multiphase pump performance prediction model.

The general principles that affect the multiphase pump performance, both the head and efficiency, are:

- Bubble size
- Density ratio
- Flow regime
- Gas content
- Reynolds number
- Speed of sound
- Viscosity

These fundamental principles were discussed in section 2.4. An understanding of how the general principles affect the multiphase pump performance is of key importance in developing a robust and accurate prediction model. The use of computational fluid dynamics along with extensive testing may contribute to that knowledge buildup.

A mixer can be introduced in front of the pump, in order to develop a dispersed flow regime at the inlet of the pump, and to obtain a certain bubble size. So, for relatively low GVF the flow can be modeled with a homogeneous model presented in section 2.3. As the GVF is increased, the chance of bubble coalescence increases, and a separated flow regime might be expected, and the two-fluid model, presented in section 2.3, may be used for modeling.

4.4.1 Computational fluid dynamics

There are still a way to go before multiphase flow in rotating machinery can be calculated accurately through the use of computational fluid dynamics. The multiphase modeling is however in development, and it would be of interest to start out with a simplified multiphase pump configuration to do flow analysis on. The homogeneous model and two-fluid model is included in commercial CFD-software such as ANSYS CFX, and can be used to analyze two-phase flow through a multiphase pump.

Aker Solutions is already using multiphase CFD for impeller design purposes, and a Master's thesis is in progress on the use of multiphase modeling on a T-junction. When the confidence in computational fluid dynamics on multiphase calculations becomes greater, it would be of interest to build up knowledge on CFD on multiphase flow in rotating machinery. The CFD-model can be validated against experiments done on a simplified pump configuration through the use of measurements and visualization. A single-stage mixed-flow impeller with plexi-glass for visualization and multiphase pressure and temperature meters for measurements. This will increase the confidence in the principles affecting the pump performance, and will be of great value when creating an accurate prediction model for the multiphase pump.

5 Aker Solutions' performance prediction model

This chapter will introduce the basic theory behind the current prediction model developed by Aker Solutions. Empirical correlations developed from test results are employed in order to conduct two-phase pump performance calculations. Other simplifications are also conducted in order to make the calculations more achievable. Some of the simplifications will be discussed and suggestions to improve the prediction model will be given. The focus has been on an operating condition with high gas volume fractions. The current performance prediction model is based on the theory in *Centrifugal Pumps* by Güllich [7], and gives a detailed description of the prediction procedure.

5.1 Simplifications and assumptions

The prediction model is based on test data from single-phase and two-phase flow on an actual pump or from CFD calculations, which is recalculated to the user supplied pump setup by utilizing affinity laws, similarity laws, and non-dimensional two-phase parameters [1]. The tests are conducted with water and air with various system pressures in order to obtain different density ratio.

The following assumptions are made in the current prediction model:

- The affinity and similarity laws apply.
- Two-phase flow with liquid and gas is assumed.
- Liquid is treated as incompressible.
- Gas is treated as perfect gas.
- Isothermal compression is assumed.
- Phase transition is neglected.
- Viscosity is modeled with single phase viscosity models.

There are many possibilities to improve the prediction model in order to make it more accurate, but in collaboration with Aker Solutions it was decided to focus on a couple of areas. Some of the assumptions will be

discussed in more detail, before the development of the prediction model is presented.

5.1.1 Thermodynamics

The current prediction model view the compression as isothermal. This is a simplification that has proven to be reasonably accurate at low GVFs. However, at high GVF, say above 0.8, the heating of the mixture during the compression should not be neglected and the polytropic model should be applied [7]. Either way, the polytropic model would give a more accurate representation of the compression of the whole GVF range.

Polytropic compression

The polytropic approach given by Schultz [15] should increase the accuracy of the prediction model, and different equations of state can be applied. This method is easily obtained in the process modeling software HYSYS, and Knudsen [9] studied the effect on the performance calculations when the polytropic model was applied instead of the isothermal model. The restriction, however, is that the test results need to contain accurate temperature measurements in order to validate the polytropic model. The MultiBooster test stand does not measure the temperature at any stages throughout the pump. Regardless, Knudsen [9] conducted a sensitivity analysis and concluded that the temperature measurement need an accuracy of about 0.002 K in order to have any value in the prediction model at high GVFs.

The direct integration

An even more accurate approach than the Schulz' approach is the direct integration approach. The direct integration approach of a given compression process uses the real gas properties along the polytropic compression path. The direct integration involves an iteration from suction to discharge condition. The approach follow a step-by-step isentropic compression approximation with a large number of steps:

$$h_p = \sum_{i=1}^{\infty} \left. \partial h_s \right|_{\eta_p} = const \quad (5.1)$$

Knudsen [10] is studying how the direct integration approach can be utilized in the performance predictions through the two-phase multipliers. As the thermodynamic and fluid properties along the compression path are updated, a benefit of the direct integration is that it includes the phase transition [8].

Accurate temperature measurements for multiphase flow is a major challenge, and since the current test loop at Aker Solutions Tranby only measure the temperature at suction and discharge of the pump with an accuracy of 0.2 K, the polytropic approach is difficult to validate. However, temperature measurements stage-by-stage through the pump and a direct integration method is something that should be considered in the future.

5.1.2 Equation of State

The gas is treated as perfect gas, which obviously is not the case. An accurate equation of state is of key importance in performance predictions. A well suitable equation of state is important in calculations of thermodynamic properties such as density ratio, enthalpy, speed of sound, etc. which again are important performance parameters. Performance parameter variations above 7% have been experienced between the most commonly used equations of state in natural gas service [8].

The performance prediction model is based on tests with air and water, but will in the end be used to predict the pump performance under oil and natural gas operation and under much higher suction pressures. The ideal gas law is expected to be very inaccurate, and a study needs to be conducted in order to find an accurate equation of state for multiphase flow under the conditions of interest.

5.1.3 Affinity and Similarity law

The similarity laws and the two-phase multipliers can be applied as a first approximation to predict performance of one stage of a two-phase pump [7], but care should be taken. The affinity and similarity laws can not be applied to multiphase flow per se. When pumping multiphase

flow the laws show good accuracy for liquid dominated flow. For gas dominated flow, however, the scaling laws does not apply. The affinity laws only applies when the hydraulic efficiency, η_h , is kept constant. That is not the case when gas is introduced to the pump. Aker Solutions solve this by applying the affinity/similarity law on the impeller as if it was single-phase flow and correct the results with the two-phase multipliers for each stage. The effects of operating with gas dominating flow on two-phase performance are then captured by the two-phase multipliers instead of the scaling laws.

Zhou et al. [17] stated that the affinity law exponents are based on single-phase flow, and that the equations are not valid for multiphase flow. Based on various trials, they developed a set of multiphase exponents with an acceptable approximation to their set of experimental data. With equation 3.6 and equation 3.7 in mind, they developed the following affinity law:

$$Q_p = Q_m \left(\frac{n_p}{n_m} \right)^{0.8} \quad (5.2)$$

$$H_p = H_m \left(\frac{n_p}{n_m} \right)^2 \quad (5.3)$$

5.2 Two-Phase Multipliers

Empirical coefficients, called two-phase multipliers, can be derived from test data for single-phase and two-phase operation. The coefficients are valid for the tested geometry and within the range of parameters investigated. The two-phase multipliers can be defined as the relation between the measured two-phase work coefficient Ψ_{TP} and efficiency η_{TP} to the equivalent single phase data (Ψ_{SPL} and η_{SPL}).

$$f_{\Psi} = \frac{\Psi_{TP}}{\Psi_{SPL}} \quad (5.4)$$

$$f_{\eta} = \frac{\eta_{TP}}{\eta_{SPL}} \quad (5.5)$$

Appendix A contains all equations needed to calculate the two-phase multipliers. Aker Solutions has up until now used a power consumption reduction factor instead of utilizing the two-phase efficiency factor:

$$f = \frac{P_{TP}}{P_{SPL}} \quad (5.6)$$

The two-phase efficiency factor is the one introduced in *Centrifugal pumps* by Gülich [7], in which the rest of the performance prediction model is based on, and is the factor that will be used in future versions of the prediction model.

The two-phase multipliers can be derived from test results in the following way:

1. A test is conducted on single phase liquid which gives the dimensionless parameters: $\Psi_{SPL} = f(\varphi)$ and $\eta_{SPL} = f(\varphi)$.
2. Tests with two-phase flow are carried out with various GVFs, ρ^*s , and q^*s .
3. Each measuring point is evaluated, and as a result $\Psi_{TP}(\alpha, \rho^*, q^*)$ and $\eta_{TP}(\alpha, \rho^*, q^*)$ are available.

4. For each data point, the flow coefficient φ is calculated with the mixture flow rate. From this flow coefficient, the single phase data from the single phase test in step 1 can be obtained.
5. Dividing the two-phase coefficients from step 3 by the corresponding SPL data from step 4 gives the two-phase multipliers defined in equation 5.4 and 5.5.

By following these steps, a matrix of two-phase multipliers can be developed for different GVF, ρ^* , and q^* . This matrix will then be used as input to the performance prediction model. When predictions are desirable at conditions other than those tested, the two-phase multipliers can be found by interpolating between the data points closest to the desirable condition. When the desired condition is outside the tested range of GVF and density ratio, care must be taken. Extrapolation is not recommended, so analytical models need to be developed in order to predict the performance outside the tested range.

Aker Solutions current prediction model is treating the two phase multiplier as a function of GVF and density ratio only. As part of this thesis it has been proposed to also differentiate two-phase multipliers as a function of q^* . This is the correct representation of the two-phase multiplier and the solution and implementation is discussed in detail in section 5.2.1.

Gulich [7] found the two-phase multipliers to be independent of impeller tip speed and consequently independent of size and speed of the pump. This implies that the two-phase multipliers developed during tests can be used for impellers of different sizes and at other speeds.

5.2.1 Revised two-phase multipliers

The two-phase multipliers in Aker Solutions current performance prediction tool is not dependent on the flow coefficient, q^* . The two-phase work factor is just dependent on density ratio and GVF, $f_{\Psi}(\alpha, \rho^*)$.

Aker Solutions collects the test data and produce a set of two-phase multipliers for different GVF, ρ^* , and q^* at different rotational speeds. However, for each density ratio, the two-phase multipliers are obtained by taking a polynomial fit of the test data with respect to GVF, making

the two-phase multiplier dependent on GVF and ρ^* only. Figure 5.1 shows how the two-phase multiplier in the current prediction model is developed. It shows that taking a polynomial fit of all the test data, may give a wrong representation of the two-phase multiplier at the flow rate of interest.

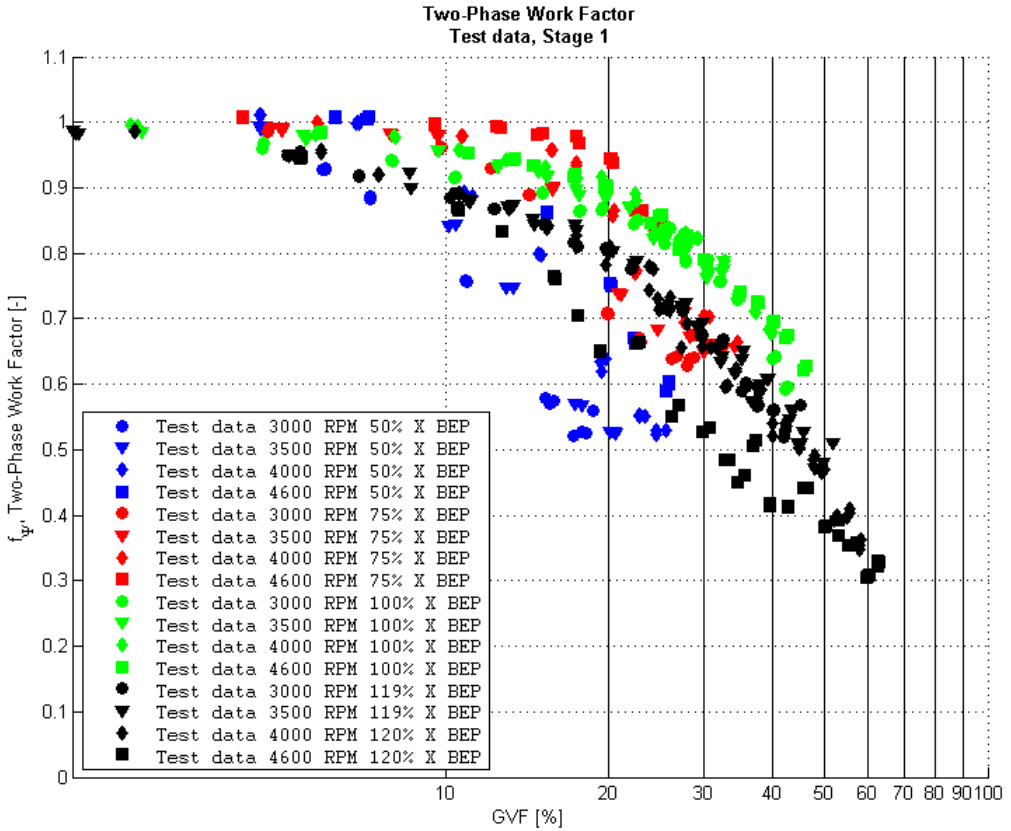


Figure 5.1: The two-phase work factor sorted for q^* at a given density ratio.

For a given GVF, the two-phase work factor deviates considerably for different volume flows. Having the two-phase multiplier dependent on the flow coefficient is believed to increase the accuracy of the prediction tool. Other literature and prediction models summarized by Pessoa et al. [13] verify the same thing.

Figure 5.2 show how the current prediction model underpredict the performance degradation at low q^* . The plot is taken from the prediction and test results on an earlier test analyzed by Halfdan Knudsen [9].

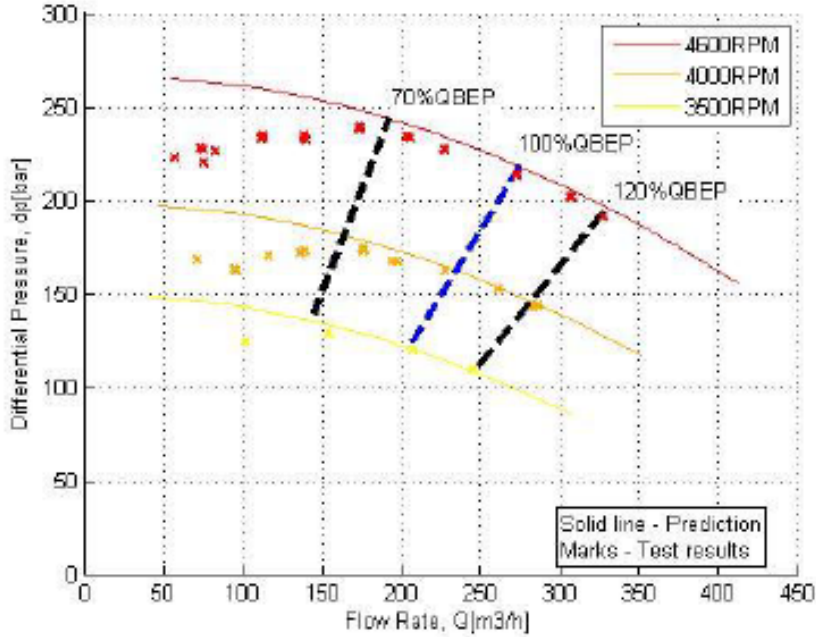


Figure 5.2: 20% GVF multi-stage differential pressure predictions and test results [9].

The prediction model underpredict the larger degradation taking place at low flow rates. The deviation between the prediction and test results at low flow, is believed to be a result of using a two-phase multiplier as a function of GVF and ρ^* only. Extending the two-phase multiplier matrix with q^* will contribute to a performance degradation at the specific volume flow of interest, rather than a fit to all flow rates. In order to improve the performance predictions, a polynomial fit should be executed for different flow rates, e.g for 50% Q_{BEP} , 75% Q_{BEP} , 100% Q_{BEP} , and 120% Q_{BEP} . When the desired volume flow is between any of the predefined volume flows, interpolation should be utilized in order to acquire the desired two-phase multiplier.

There was also of interest to verify if the two-phase multipliers are independent of rotational speed or not, which was claimed by Gülich [7]. The test data from the tests described in chapter 6 was used for post-processing, and the two-phase work factor was developed.

The experimental data from the current tests has been analyzed in order to develop the two-phase multipliers needed as input to the performance prediction model. The experimental data has been filtered to obtain the data at the specific flow rate of interest. The two-phase work factor for different rotational speed was plotted at a given % Q_{BEP} for various GVFs for the first stage. Figure 5.3 show how the two-phase work factor varies for different rotational speed at 100% Q_{BEP} .

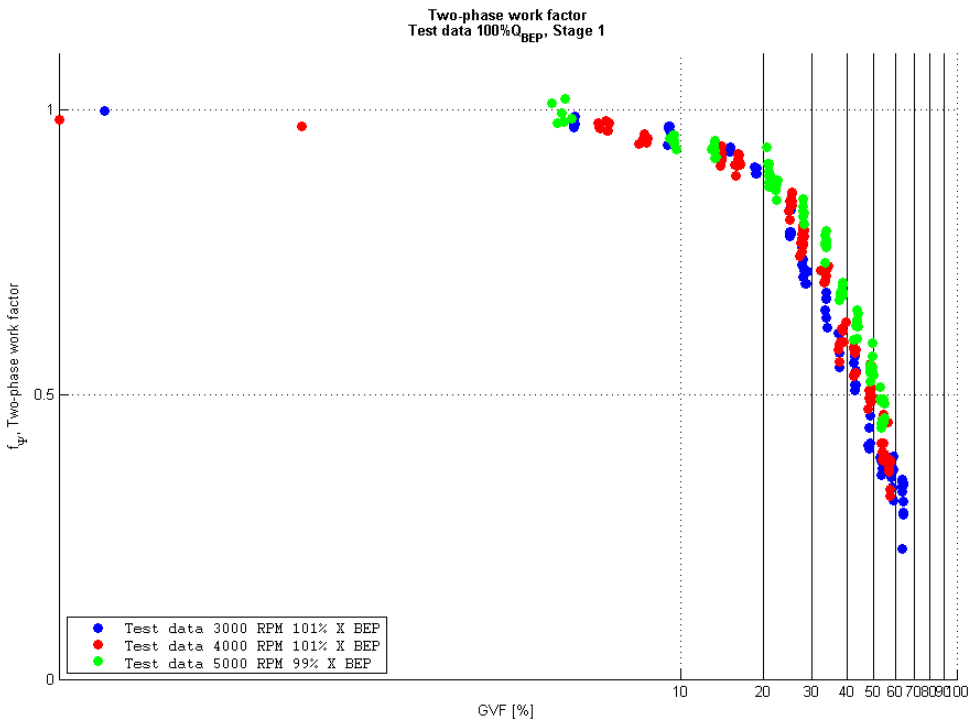


Figure 5.3: Two-phase work factor for different rotational speed at 100% Q_{BEP}

The analyzed test data supports the theory that the two-phase multiplier is independent of speed. However, this seems not to be the case based on the test data for 50% Q_{BEP} . In figure 5.4 the two-phase work factor is plotted at 50% Q_{BEP} for different rotational speeds.

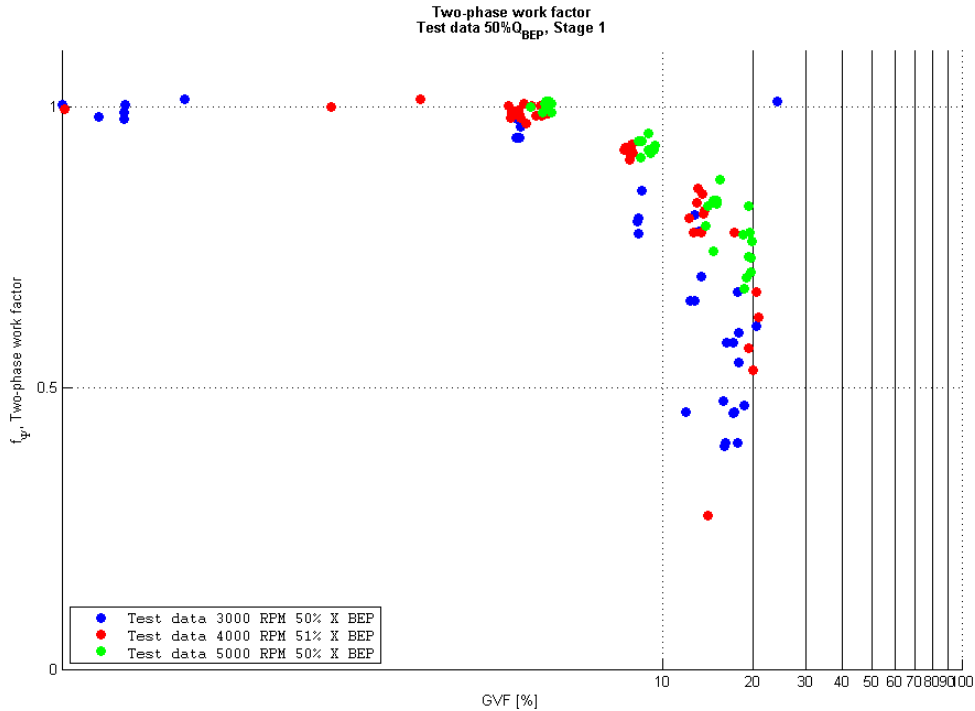


Figure 5.4: Two-phase work factor for different rotational speed at 50% Q_{BEP}

A lower performance at 50% Q_{BEP} and 3000 rpm is expected as separation occurs easier here than at higher volume flows and rotational speeds. However, a deviation is observed, and the plots for 75 % Q_{BEP} and 120 % Q_{BEP} has been included in appendix B. These plots indicate that the two-phase multiplier may be dependent on the rotational speed, and a further analysis of the test data is required. Some variations in the two-phase work factor are expected due to small variations in density ratio, but the variation especially between 3000 rpm and 4000/5000 rpm for

50% Q_{BEP} is something that should be looked at in the future when more test data is available.

5.2.2 Sorting of the two-phase multiplier

It would be of interest to extend the two-phase multiplier matrix, and making the prediction model dependent on q^* is something that has to be developed in the future. The test results were sorted using MatLab, and a plot were made that show how the two-phase multiplier is dependent on q^* , see figure 5.1. A polynomial fit is made for each q^* , such that for each GVF at a specific q^* , the two-phase multiplier can be determined. Figure 5.5 shows the 2nd order polynomial fit for 50% Q_{BEP} , 75% Q_{BEP} , 100% Q_{BEP} , and 120% Q_{BEP} .

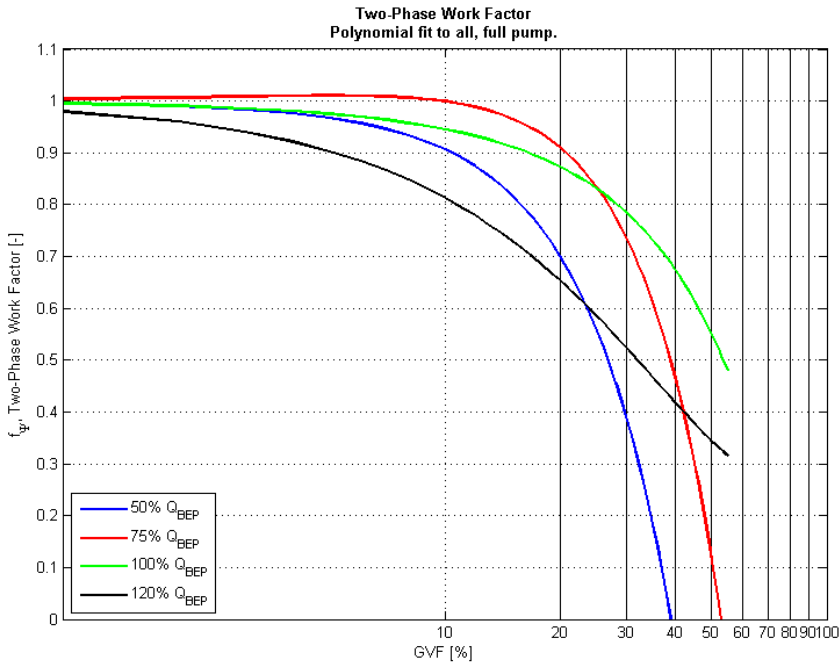


Figure 5.5: A 2nd order polynomial fit for the two-phase multiplier at different q^* at DR=44.

Figure 5.5 clearly shows that the two-phase multiplier is dependent on q^* . After the polynomial fit is developed, it is then stored and used to develop a test matrix which is used as input to the prediction model. Table 5.1 show how an arbitrary test matrix will look like. This test matrix will be used in the prediction model. When predicting the pressure increment over a stage inside the pump, the prediction model utilize the two-phase multiplier at the condition of interest. The equations and procedure used will be given in detail in section 5.3. When an area of interest is between measured density ratios and/or flow rates, the point of interest can be developed by interpolating between the two closest test matrices.

[Two-phase work factor set X]

$$DR = X$$

$$q^* = X$$

GVF	f_{Ψ}
0	1.0
10	0.9453
20	0.8730
30	0.7829
40	0.6751
50	0.5496
60	0.4065
70	0.2456

Table 5.1: A test matrix at a given DR and q^*

5.3 Performance prediction

The performance of a multistage pump is calculated stage by stage. The outlet condition from one stage act as the inlet condition to the following stage. Parameters such as gas density, flow rate, and velocity triangles change from stage to stage due to compression of the gas phase. The performance prediction model follows these ten steps:

1. Determine liquid and gas properties, flow rates, gas fraction, and density ratio.
 - Determine the suction conditions: P_s , T_s , the flow rate for each phase and determine the GVF and GMF , eq. (2.1) and eq. (2.2).
 - Determine the pump layout: number of stages (how many mixed flow impellers and how many radial impellers).
 - Set desired rotational speed for the prediction.
2. Determine stage inlet fluid properties.
 - The stage inlet gas properties are calculated via the ideal gas law which relates the state of the gas to its pressure, volume and temperature according to:

$$pV = const \quad (5.7)$$

Knowing the gas and liquid properties at the stage inlet allows for calculating dependent properties, such as GVF and density ratio, which are necessary to calculate the pump performance.
3. Select hydraulics and single-phase liquid performance curves.
 - Get the single-phase performance data consisting of flow rate, head, and power consumption, [Q , H , P], from the single-phase test data.
 - Apply affinity/similarity law, eq. (3.6) - eq. (3.8), for other impeller sizes or speeds.
4. Calculate the flow rate coefficient φ , eq. (3.10), at the inlet and determine Ψ_{SPL} and η_{SPL} from the single-phase data in step 2.

5. From test data at given GVF, DR, and q^* , determine f_Ψ and f_η from table such as table 5.1.
6. Calculate the pressure rise, assuming constant temperature.
 - The pressure rise is determined by rearranging the equation for specific work in appendix A, eq. (A.2):

$$(1 - x) \frac{p_2 - p_1}{\rho_{liq}} + xRT \ln \frac{p_2}{p_1} - f_\Psi \Psi_{SPL} z_{st} \frac{u_2^2}{2} = 0 \quad (5.8)$$

7. Adjust the data for viscosity, see section 5.3.1, from either:
 - Empirical correction.
 - Loss analysis.
 - Correlations.

Correct pressure, flow, and power consumption.

8. Calculate the accumulated power consumption and efficiency.
9. Repeat step 2 to 8 for each stage throughout the pump.
10. Calculate the efficiency.

The performance prediction model is developed in MathWorks' MatLab. Figure 5.6 show a flow chart of the current prediction model.

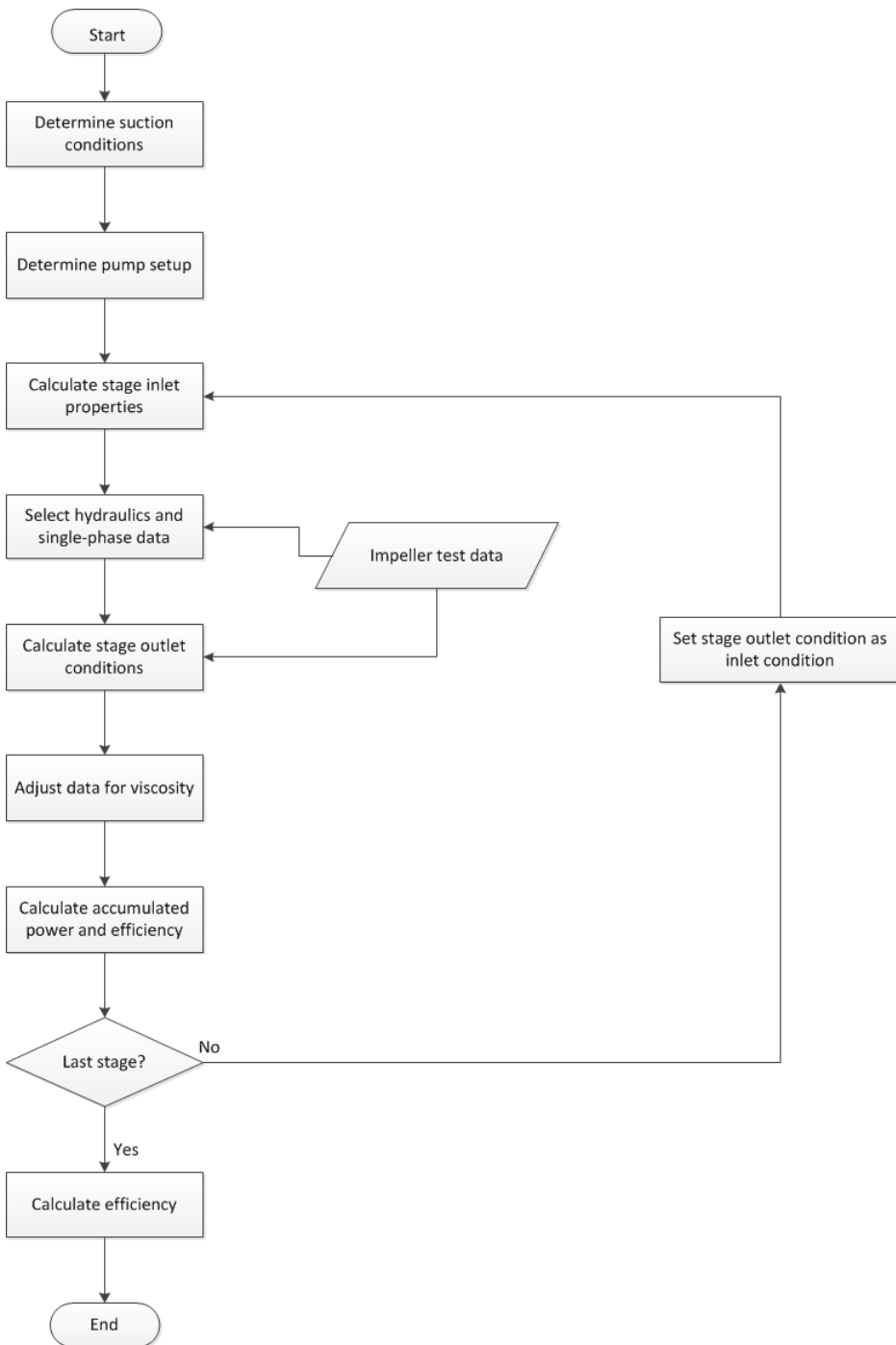


Figure 5.6: Flow chart of the current performance prediction model.

5.3.1 Two-phase viscosity

Tests are conducted with fresh water and air as test mediums. The test results for water and air are corrected when predictions are made for pumping of viscous fluids. The effects on the pump characteristics when pumping viscous fluids is more unexplored for two-phase flow than for single phase flow. Gülich [7], mentions just a few words about its influence, namely that when pumping oil/gas mixtures, an increase in oil viscosity is expected to reduce phase separation and slightly improve the two-phase performance. Gülich [7], claims that the improvement is mostly for $q^* > 1$ and only little effect is seen at part load and near BEP.

Aker Solutions has not yet included a method that corrects for viscosity of multiphase flow. The current prediction model let the user choose between three different single phase viscosity models, namely loss analysis, correlations, and empirical corrections based on the Hydraulic Institute or KSB-Kreiselpumpen-Lexikon data. These models corrects the performance as if it was single-phase flow. The different models have been compared in earlier works, and did not show satisfactory resemblance. Research and literature study must be conducted, making a better choice basis for the different models.

The models can be validated against existing single-phase viscous test results, and should be validated against multiphase viscous test results as soon as such exists.

Hydraulic institute

The Hydraulic Institute (HI) made a generalized procedure for correcting centrifugal pump performance when handling viscous fluids. The procedure estimates the pump performance with viscous fluids based on an empirical approach. An empirical parameter, B, is used to develop the correction factor for flow rate, head, and efficiency.

$$B = \frac{480\sqrt{\nu}}{Q^{0.25}(gH)^{0.125}} \left(\frac{n_{q,Ref}}{n_q} \right)^{0.25} \quad (5.9)$$

$$f_Q = e^{-0.165(\log B)^{3.15}} \quad (5.10)$$

$$f_H(q^*) = 1 - (1 - f_{H,BEP})(q^*)^{0.75} \quad (5.11)$$

$$f_\eta = B^{-0.0547B^{0.69}} \quad (5.12)$$

Loss analysis

With well known geometry the method of correction is performed via loss analysis rather than empirical procedures. If sufficient geometrical data of the pump of interest are available, a loss analysis described in *Centrifugal Pumps* [7] is expected to give the most accurate results.

Correlations

If an exact loss analysis is not required an empirical correlation of data gained from a loss analysis can be used. This method use the modified Reynolds number is order to develop the correction factors.

$$Re = \frac{ur_2}{\nu} \quad (5.13)$$

$$Re_{mod} = Re\omega_s^{1.5} f_q^{0.75} \quad (5.14)$$

$$f_{H,opt} = [Re_{mod}]^{-\frac{6.7}{Re_{mod}^x}} \quad (5.15)$$

$$f_{\eta} = [Re_{mod}]^{-\frac{19}{Re_{mod}^y}} \quad (5.16)$$

$$f_Q = f_{H,opt} \quad (5.17)$$

$$f_H(q^*) = 1 - (1 - f_{H,opt})(q^*)^{0.75} \quad (5.18)$$

where the exponents are given in table 5.2

Exp.	Min.	Mean	Max
x	0.68	0.735	0.81
y	0.65	0.705	0.77

Table 5.2: Correction factor for exponents x and y.

The prediction of multiphase viscosity is a complex field of study, and requires much attention. A more thorough literature study should be conducted, and different models should be validated against multiphase tests with viscous fluids. There could also be of interest to run the multiphase pump with a viscous multiphase mixture, in order to learn more of the pumps capability of handling viscous fluids.

6 Prototype performance test

The experimental tests were conducted at Aker Solutions Technology & Manufacturing Center Tranby. The purpose of the test is to obtain test data in order to map the performance of the mixed flow impellers and diffusers, verify the design of a gas tolerant radial impeller as well as thrust force calculations. The results will prove if the pump design provides the desired performance. Due to prioritizations and time schedule, the tests were conducted on Aker Solutions' HybridBooster. The HybridBooster has a lower GVF-target than the MultiBooster, but the same test procedures apply. Modifications have been made to the hydraulic design, firstly in order to increase the gas tolerance of the pump, and secondly to improve the manufacturability of the impellers and diffusers. The available impeller performance data is today based on the test conducted on previous design and a deviation between the pump prototype performance and the prediction is therefore expected. New test data will be used to obtain an accurate description of the exact tested geometry, and update the input data required by the prediction model. Relevant test data was documented and analyzed. This chapter will give a general explanation of the experimental setup and procedure, and some of the challenges met during testing will be discussed. When collecting experimental data it is important to be aware of the accuracy on the test data. Care must be taken, and the result should be analyzed in order to be confident on the data. This chapter will include a short discussion about the measuring equipment, its accuracy and how they are used.

The test data is strictly confidential, so the relevant performance parameters documented in this thesis are made dimensionless.

The prototype performance test was first planned in February, but was postponed till beginning for April. Table 6.1 shows the three different prototype configurations planned to be tested. The test plan only allowed access to the 3 stage test whilst the other configurations were not tested during the course of the thesis.

Config.	Pump config.	Comment
1	1 stage	One mixed flow stage
2	2 stage	Two mixed flow stages
3	3 stage	Two mixed flow stages and one radial stage with primitive diffuser.

Table 6.1: Pump prototype configuration

6.1 Experimental setup

A simplified P&ID (Piping and instrumentation diagram) is shown in Figure 6.1. This P&ID represents the experimental setup for the HybridBooster test stand at Tranby. The experimental setup is relatively simple, but is sufficient in measuring the two-phase performance of the HybridBooster. The experimental procedure will be explained in section 6.2.

The system consists of a closed loop, where gas and liquid is separated in a continuously working separator. Liquid is drained from the bottom of the separator and gas from the top. Each phase is measured separately and mixed in front of the pump. The gas enter the main pipe through a t-junction. A throttle valve is placed in front of the t-junction in order to throttle the liquid flow, creating a pressure difference between the two phases, making the gas flow easily through the t-junction. A heat exchanger is placed after the separator in order to control the liquid temperature. It is desired to keep the liquid under a certain temperature, keeping touchable surfaces, such as pipes, below the risk of heat damage. The pump casing is rigged in horizontal orientation on a dedicated test skid. A step-up gear will increase the speed from the main motor (M), up to the desired range, 3000-5000 rpm. The main pump discharge pressure is choked down by an electro-hydraulic actuated choke, located directly after the pump discharge. The operability of the pump during test is maintained by manually controlling the speed and flow through the pump. The liquid flow through the pump is maintained by manually

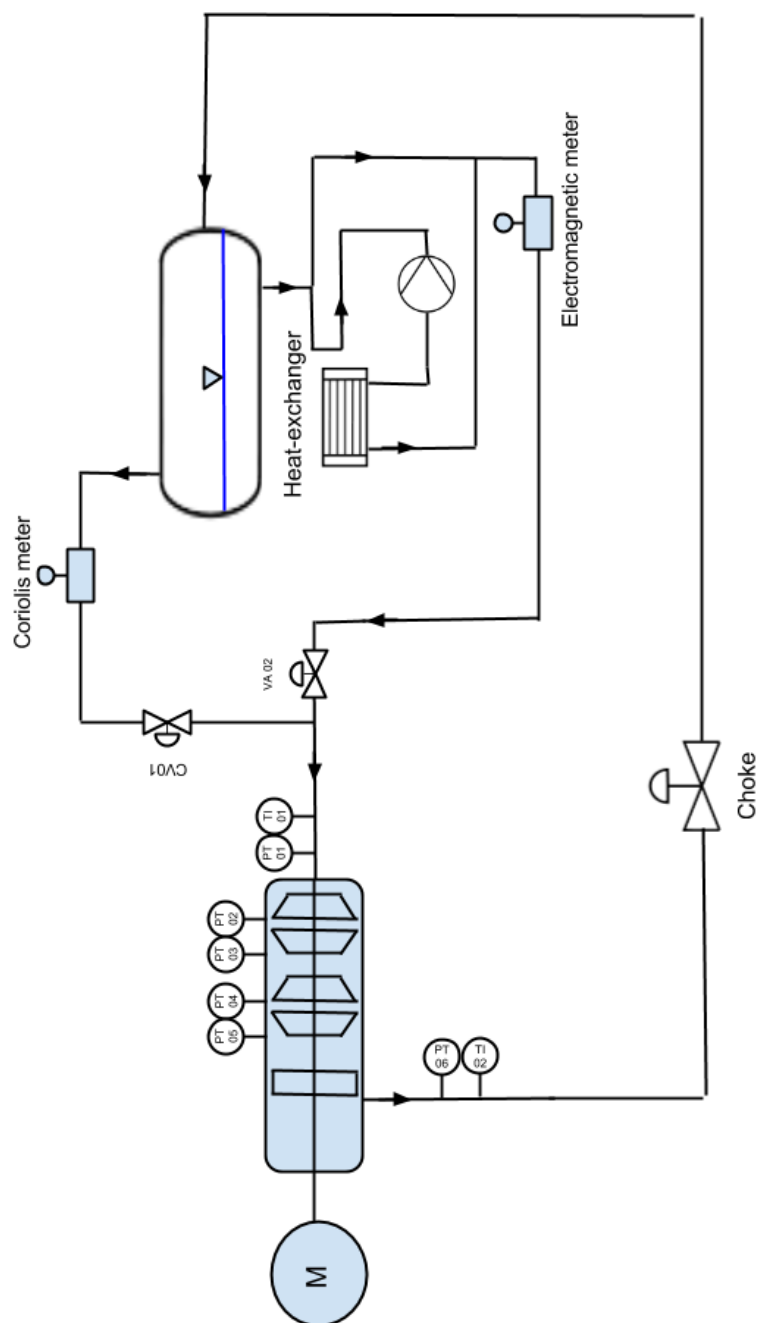


Figure 6.1: Simplified P&ID for HybridBooster test stand

adjusting the discharge valve, and the gas content is manually controlled by adjusting the control valve, CV01.

Fresh water as the liquid phase and air as the gas phase is chosen as test medium during testing. The pump cartridge consists of two mixed-flow impellers and one gas-tolerant radial impeller, with pressure meters between the impellers and diffusers in order to measure the stage pressure increment. The process parameters from the pump and test loop was monitored and logged continuously during the testing and stored in a database.

The main limitation in the test loop is the relatively low system pressure. The separator restricts the system pressure in the test loop to approximately 11 *barg*, causing a low latitude of corrections in the throttling. This is something that will be improved in the future by rebuilding the test loop.

6.1.1 Instrumentation

Data is logged with a sampling frequency of 1 *Hz* to a database during testing. The liquid flow is measured using a magnetic flow meter while the gas is measured with a coriolis flow meter. The most important instruments for producing the pump curves are the pressure transmitters, gas and liquid flow meters and torque/speed meter. The measurement need to be as accurate as possible in order to have any value as a basis for the prediction model or as a part of the performance prediction validation. There will always be some uncertainties in the measurements, but all measurement uncertainties is in compliance with ISO 9906, grade 1 [2], see table 6.2. As the measurements tends to fluctuate, a sample of measurements are collected at each measuring point and the average is taken. As gas is introduced to the flow, fluctuations are expected due to flow regime and bubble size variations. Especially at higher GVF regions. Both dynamic and static pressure sensors are utilized inside the pump.

	Grade 1
Flow	1.5 %
Speed	0.4 %
Power	1 %
Head	1 %

Table 6.2: Instrumental uncertainties at guarantee point, ISO 9906 (+/-)

The power consumption is obtained by a torque meter, measuring the torque on the pump shaft, and the rotational speed. This gives the actual power consumption of the pump regardless of the motor efficiency.

6.2 Experimental procedure

The test procedure is conducted with respect to the requirements in API 610. In addition to the API requirements, tests has been performed in order to obtain a full mapping of the pump performance when subjected to gas. To map any hysteresis in the pump, this gas testing has been performed in numerous manners as described in table 6.3 below. The test procedure is divided into three stages.

Test mode	Sub mode	Test description
1	TCV	Single phase testing towards closed valve (TCV).
	TOV	Single-phase testing towards open valve (TOV).
2		Two-phase testing at constant speed and constant flow rate with continuously increased GVF. Speeds: 3000 – 4000 – 5000 rpm. Flow rates: 50 – 75 – 100 – 120 % BEP.
3	TCV	Two-phase testing at constant speed and constant GVF towards closed valve. GVF shall start at 10% and increase by 10 percentage points until instability occurs. Lastly, a test on 5 percentage points higher than the last stable GVF value should be performed, if possible without experiencing instability.
	TOV	Two-phase testing at constant speed and constant GVF towards open valve. GVF shall start at 10% and increase by 10 percentage points until instability occurs. Lastly, a test on 5 percentage points higher than the last stable GVF value should be performed, if possible without experiencing instability.

Table 6.3: Experimental procedure divided into three stages

Test mode 1

Before running two-phase tests, single-phase tests, were initially conducted. These tests develop the single-phase pump performance data used to develop the single phase work coefficient needed to develop the two-phase multipliers in the performance prediction model. The test data does also form a set of flow, head, and power data (Q, H, P) which can

be used in the affinity/similarity laws. The single-phase experimental matrix was designed by varying the liquid flow rate, and pressure increments were developed from pressure measurements. Tests are conducted towards closed and open valve in order to map any hysteresis in the pump. The discharge valve, choke valve, and rotational speed is manually adjusted in order to obtain the desired operating condition. Figure 6.2 illustrates how the pump is operated along the pump characteristics for test mode 1.

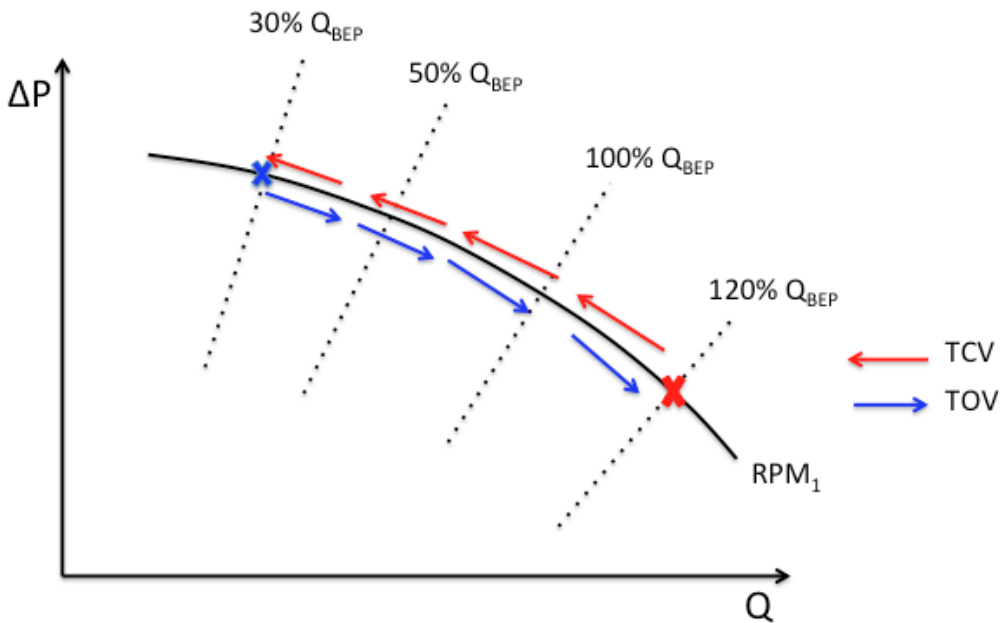


Figure 6.2: Test mode 1; single phase testing at constant speed TCV/TOV.

The choke valve is manually adjusted to maintain a flow between $30\% Q_{BEP}$ and $120\% Q_{BEP}$ at 3000, 4000, and 5000 *rpm*.

Test mode 2

The rotational speed and total volume flow is kept constant, while GVF is adjusted from 0% GVF with a 5 percentage point increment until instability occurs. For each rotational speed and total volume flow, the test develops the boundary where instability occur. Figure 6.3 illustrates how rotational speed and the total volume flow is kept constant as the GVF is changed. In order to inject gas to the flow a pressure difference in the flow a t-junction is created by a throttling valve, giving the gas approximately 1 bar higher pressure. At each measuring point, an average of several measurements is used to prevent insecurities in the fluctuations in the measurement devices.

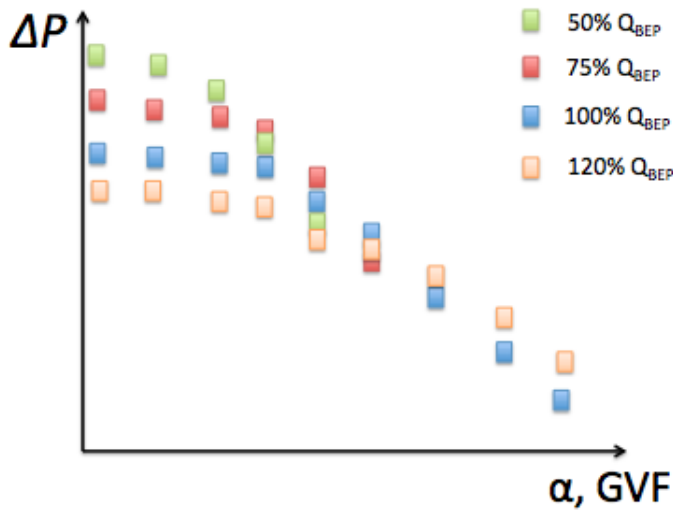


Figure 6.3: Test mode 2; two-phase testing at constant speed at different flow rates with varying GVF.

Test mode 3.

Test mode 3 is similar to test mode 2, but with a different approach. In test mode 3 the GVF is kept constant and the pump curves are produced. This is done at 10% GVF and repeated in increments of 10 percentage points. Test mode 3 does also search for any hysteresis in the pump as the pump is operated towards closed and open valve. The GVF is then changed with a 10 percentage point increment towards instability. As instability occur, the GVF is lowered 5 percentage points. This is to map where instability occur, and establish the pump prototype capability of handling GVF. Figure 6.4 show how the pump is moving along the pump characteristics as the GVF and rotational speed is kept constant towards a closed valve.

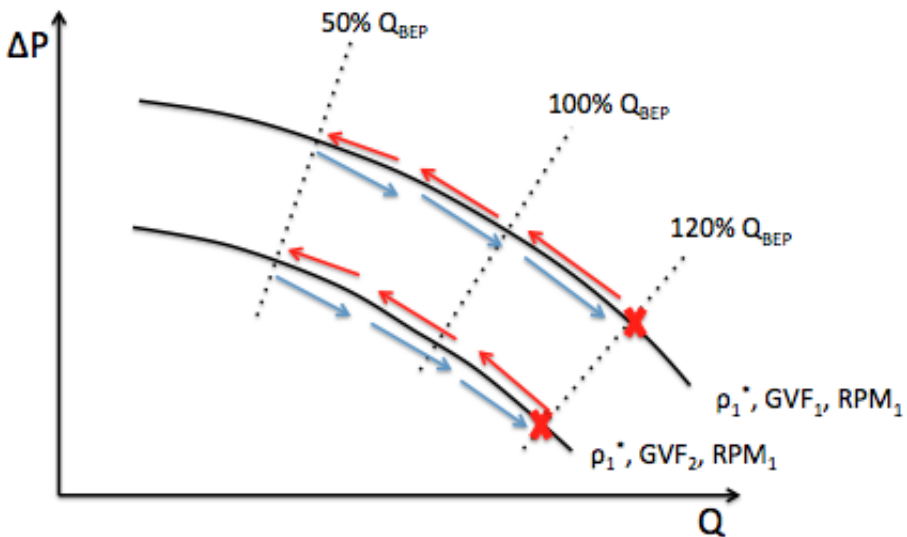


Figure 6.4: Test mode 3; two-phase testing towards open and closed discharge valve.

6.3 Experimental data

A huge amount of data is stored continuously during the tests. The data is then collected, sorted and is used for post-processing. The experimental data show how well the pump configuration operates under various conditions. The data form the basis for the development of the two-phase multipliers for the mixed-flow impellers as well as for the gas-tolerant radial impeller used as input to the performance prediction tool. A sample of measuring data is collected at each condition of interest, and an average is taken of the sample in order to eliminate the fluctuations observed in the measurement data. No international standard is currently available for multiphase pump testing, so the ISO 9906 for single phase pump testing has been used to have a rule of thumb when it comes to acceptable deviations in measurement data. As long as the data was within the range of 10%, an average was taken to create one point on the graph. The sampling size is dependent on the measurement deviations, but was kept around 10-15 measurements per sample.

6.3.1 Test Mode 1

Test mode 1 develops the single phase performance characteristics, which is an important basis for the use of the affinity/similarity laws and the development of the two-phase multipliers used in the performance prediction model. The single phase testing does also show how well the mixed-flow and gas-tolerant radial impellers perform under single phase operation. Figure 6.5 show the performance prediction along with the test data for the pump in single phase conditions from 30% Q_{BEP} to 120% Q_{BEP} . As can be seen from the plot in figure 6.5, the pump has a better performance than predicted. This can be related to the modifications to the hydraulic design of the impellers and diffusers and it is suggested to update the prediction model input data, i.e the impeller performance description.

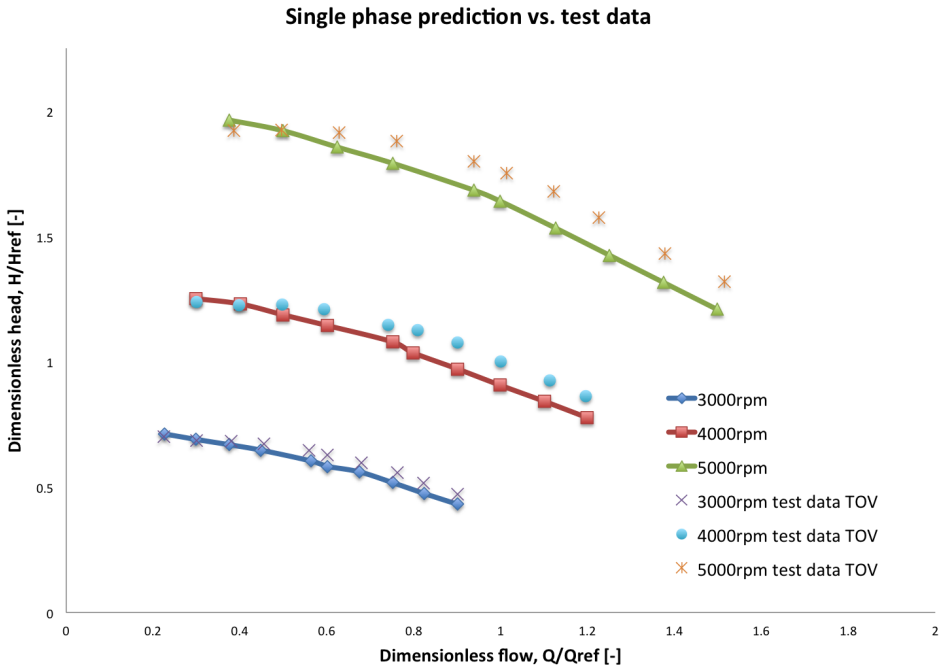


Figure 6.5: Single phase pump performance predictions along with test results for 3000, 4000, and 5000 *rpm*.

If this design is chosen, the single phase performance data can be used to develop the input data to the prediction model. The two-phase multiplier is an essential part of the performance prediction model, see section 5.3, and is dependent on the single phase and two-phase work coefficients developed from test data.

The input data to the prediction model is dependent on performance data from each stage. The procedure is explained in detail in section 5.2. Figure 6.6 shows the stage performance for the three different stages.

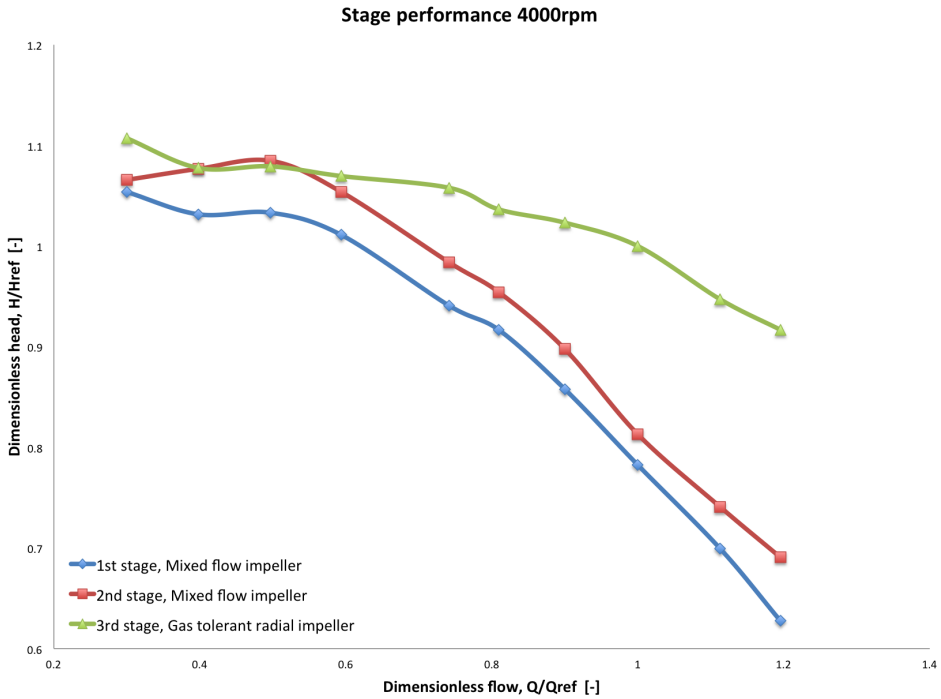


Figure 6.6: Single phase stage performance at 4000 rpm

The figure shows that the radial impeller has the best single phase performance, which is expected. The 2nd stage shows a slightly better performance than the 1st stage. This might be because the 1st stage diffuser provides a better inflow condition to the 2nd stage than the mixer does for the 1st stage, or that the 2nd stage diffuser has a better performance than the 1st stage diffuser.

The new stage performance test data can be used to develop the single phase work coefficient by following the procedure introduced in section 5.2. The single phase tests can also be used to develop a set of single phase performance data, which forms the basis for the two-phase efficiency factor and the affinity/similarity laws. However, test data for stage power consumption is not available, and can therefore not be developed at this stage.

Test mode 1 does also check whether or not there are any hysteresis

in the pump performance by measuring the pump performance towards open valve (TOV) and towards closed valve (TCV). Figure 6.7 show the results from these tests.

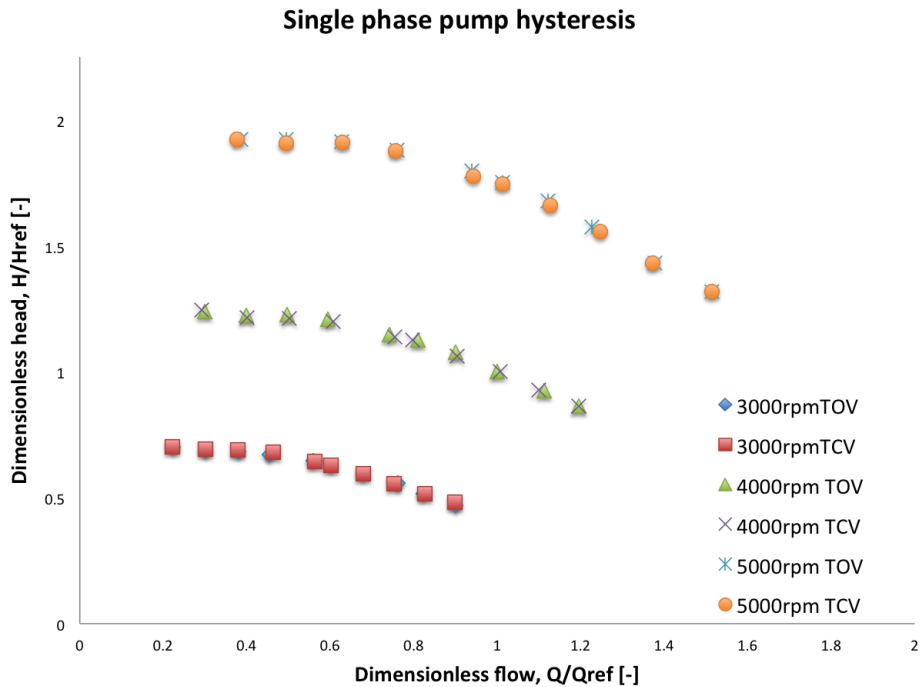


Figure 6.7: Single phase pump hysteresis TOV/TCV

As can be seen in the figure, there is no hysteresis in the pump characteristics. The single phase performance data shows promising results, however, a closer look at the performance data at 40% Q_{BEP} and 50% Q_{BEP} show that the curve is almost flat, which is not desirable from a stability point of view.

6.3.2 Test Mode 2

The test data for test mode 2 is sorted with respect to rotational speed and volume flow. Each matrix with constant speed and flow, gives the pump performance data for varying GVF. Figure 6.8 show the pump

performance at constant rotational speed at different volume flows with varying GVF. These results can be used to develop the two-phase work coefficient, $\Psi_{TP}(\alpha, \rho^*, q^*)$, needed in the performance prediction model, by using the equations in Appendix A .

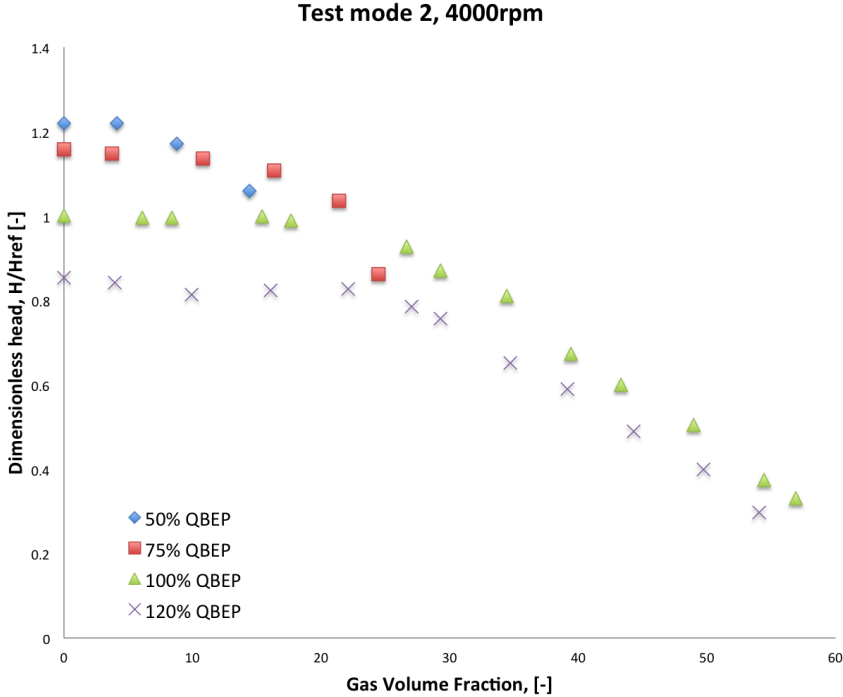


Figure 6.8: Pump performance at 4000 *rpm* for different volume flow with varying GVF.

For 50% Q_{BEP} and 75% Q_{BEP} the GVF was increased until instability occurred. The instability observed at the low flow cases can be related to test set-up limitations or pump instability. It is hard to determine this based on these tests. It might be related to fluctuating outlet conditions that propagates through the pump and disturbs the injection of gas into the liquid. It may also be due to a bubbly flow - slug flow transition. The gas bubbles coalesce and the two phases separate. This slug flow regime causes instability and oscillations in the pump head and flowrates. Further testing and analyses needs to be conducted in order to determine

the cause of the instabilities. For 100% Q_{BEP} and 120% Q_{BEP} , however, limitations in the test loop was observed. The test loop was not able to deliver a higher GVF, and the pump was still under stable operation at 60% and 65% GVF. This is due to the relatively low system pressure, which made it impossible to deliver higher GVFs at high volume flow rates. This is however not a big deal for the HybridBooster, since the GVF target is 30%. The tests gave results for a good margin above 30% GVF for 100% Q_{BEP} and 120% Q_{BEP} .

Test data for 3000 and 5000 *rpm* is plotted and included in appendix C. The test data form a set of test matrixes such as the one in table 5.1 which can be used in the performance prediction model.

The test result for 5000 *rpm* and 120% Q_{BEP} showed something unexpected. Figure 6.9 show the two-phase work factor for 3000, 4000, and 5000 *rpm* with 120% Q_{BEP} against GVF for the first impeller.

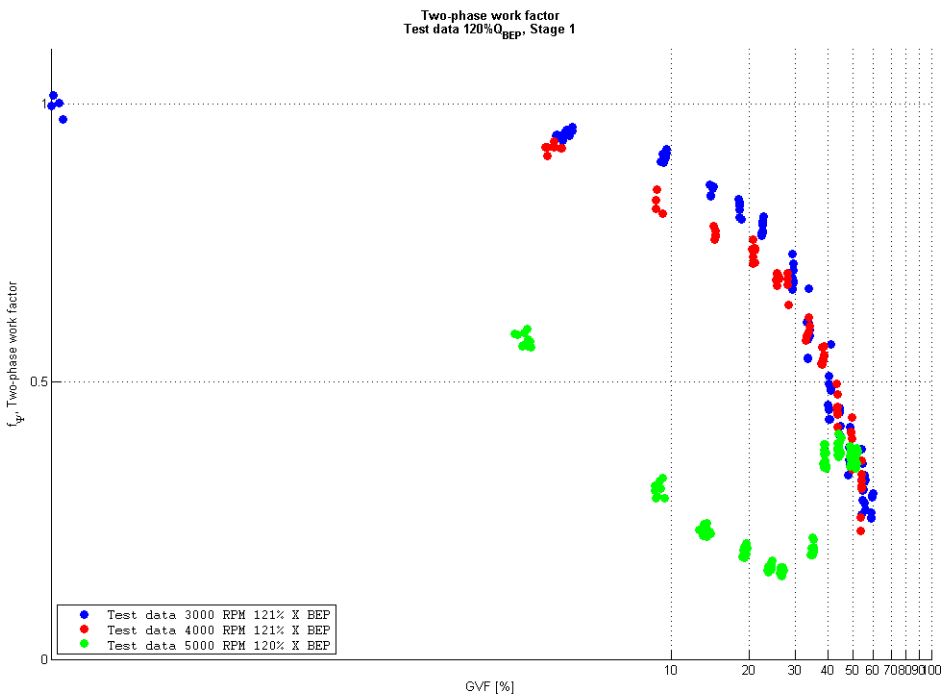


Figure 6.9: Stage 1 performance at 5000 rpm 120% Q_{BEP} with varying GVF.

As can be seen, the impeller two-phase performance for 5000 *rpm* is low from around 2% GVF and picks up again at about 40% GVF. Why this is, is not easy to predict, but it might be a gas accumulation through the impeller or choking of the flow, causing the performance to drop. A gas-blocking is less likely at such low GVFs. It can however arise from a local pressure depression on inlet edge or locally in the flow channel. This will cause a growth of the gas volume and lead to blocking of the flow. Mach number has a huge effect on multiphase pump performance, and speed of sound varies with GVF. Local speeds inside the impeller may induce local choking, causing a high performance degradation. If this is caused by the pump design or test loop is hard to say. This is something that should be studied further when testing is on the schedule again. The next stages does not show any indication of drop in performance. The same effect is observed in test mode 3 for 5000rpm and 120% Q_{BEP} , and is included in appendix D.

6.3.3 Test Mode 3

The test data for test mode 3 is sorted with respect to rotational speed and gas volume fraction. Each matrix with constant speed and GVF, gives the pump performance data for varying flow. Figure 6.10 show the pump performance at 3000rpm and various GVF along with the single phase performance characteristics.

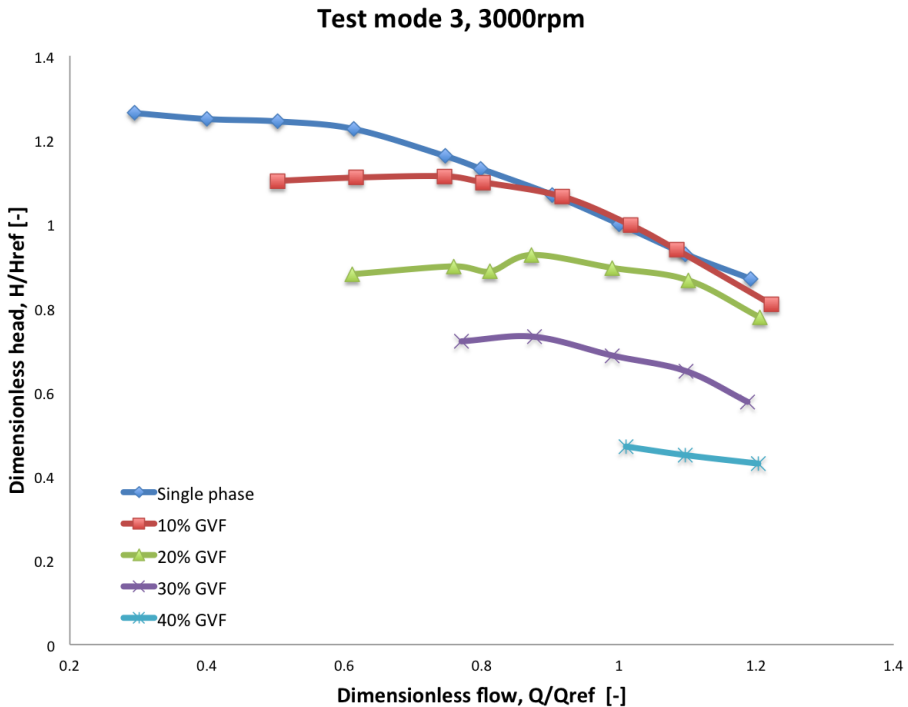


Figure 6.10: Pump performance at 3000 rpm for different GVF with varying volume flow.

As the operating point is moved towards closed valve, and the GVF is increased, instability occurs. Figure 6.10 show how well the pump performs under various conditions. As more gas is introduced to the flow, the pump requires a higher volume flow to avoid instability. Higher flow rates cause better mixing and less phase separation, and increase the gas tolerance of the impellers.

The pump efficiency at 3000rpm for various GVF is plotted in Figure 6.11 to show how the efficiency changes as gas is introduced to the pump. As can be seen in the figure, the efficiency decreases as the GVF is increased.

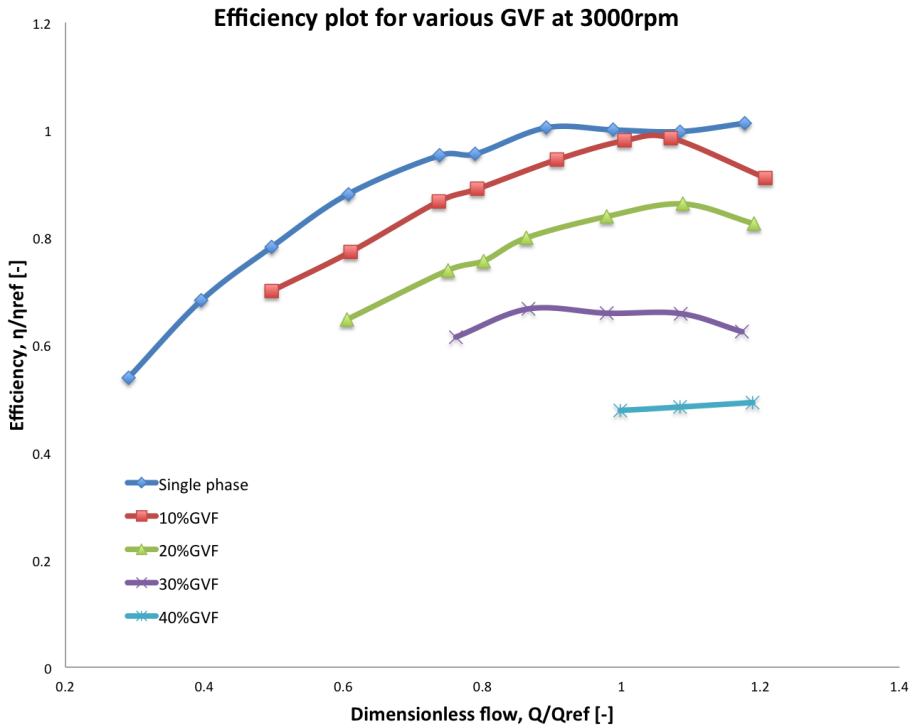


Figure 6.11: Pump efficiency at 3000 *rpm* for different GVF with varying flow.

As the gas volume fraction is increased, the operating range becomes smaller. For high GVFs, a high volume flow is required in order to prevent unstable operation and surge. Recirculation of flow is required in order to operate at high GVFs. Operation with viscous fluid will expand the operating range, due to less separation, but the performance will drop, see section 2.4. Again there is an uncertainty whether the instabilities observed is due to pump instabilities or test-loop limitations.

The plots for 4000 and 5000 *rpm* is included in appendix D.

A plot with the performance prediction and test results are included in order to compare the new pump performance with previously runned tests. Figure 6.12 shows the predictions made by the prediction model with the available impeller performance data along with test results for 3000 *rpm*.

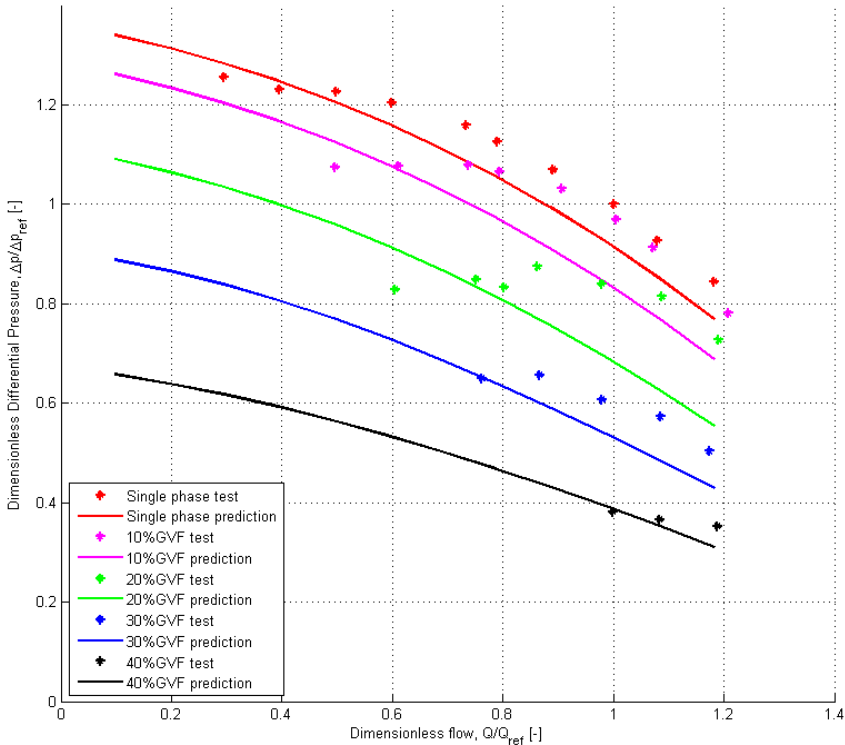


Figure 6.12: Performance predictions vs. test results for 3000rpm with various GVFs.

As can be seen in the figure, the pump has a better performance than predicted. As in section 6.3.1, this can be related to the modifications to the hydraulic design of the impellers and diffusers. This, along with the single phase predictions shows that the impeller performance data should be updated, and used as input data to the prediction model before further

validations are made.

As the current performance prediction model utilizes the power consumption reduction factor, the two-phase efficiency factors needs to be implemented before the efficiency predictions gets validated.

6.4 Suggestions to further work

The next stage of the HybridBooster test procedure will be to run tests on a one- and two-stage pump. With a one-stage impeller test, the performance, power consumption, efficiency, and thrust forces is isolated to the specific impeller and will give valuable information which can be used to analyze the pump performance as well as in the development of the performance prediction model.

Even though the low system pressure did not affect the test results to a high degree, the test loop should be reinforced before testing the Multi-Booster, which has a GVF target of 70 %. A higher system pressure will give a larger latitude of regulation. However, in the development of the performance prediction model, it is desired to adjust the system pressure in order to develop performance data at various density ratios, required in the development of the two-phase multipliers. A higher system pressure will also reduce the tendency for loop instabilities.

Visualization is of key importance in order to increase the knowledge and to be certain of what is affecting the pump performance. Test results alone gives an uncertainty of what is actually causing the pump to perform as it does. Visualization at the pump suction as well as visualization of the impeller channels along with test results will give knowledge of what is causing the performance degradation.

7 Validation of existing performance model

The HybridBooster tests were conducted with a new hydraulic design configuration. The available impeller performance data is today based on the test conducted on previous design and a deviation between the pump prototype performance and the prediction is therefore expected. This was seen in section 6.3.1 where the single phase performance prediction was included in the single phase test results plot, as well as in section 6.3.3 where performance prediction was plotted along with test results for 3000 rpm with various GVFs. The test data can be used for post-processing in order to create the required input files for the performance prediction model. When the input files are updated, and the prediction model is run at the same inlet conditions as during testing, the prediction model can be validated against the test results. Validating the performance model against test data from the prototype pump, in which the model input is based on, should correspond well with the test data. It is also desirable to run the prediction model against a model pump with a new set of tests results, in order to see how well the prediction model correspond against a pump at other conditions than which the input data is based on.

However, the current test procedure does not include enough information in order to develop the input data required by the performance model. Valuable tests has been postponed, and was not conducted during this Master's thesis. The HybridBooster test configuration and test procedure is well explained in chapter 6. The test procedure restrictions and what has to be done in order to develop and validate the performance model will be discussed in this chapter.

7.1 Performance model

The performance model is dependent on a set of input data. These input data must come from test results from a pump with a similar hydraulic design. A set of performance data on both single phase and two-phase flow is required for the prototype pump. Affinity and/or similarity law can be applied if the model pump of interest has a different diameter and/or impeller scale. The single phase and two-phase performance data

is needed in order to develop the two-phase work and efficiency factors in the input data. These data tells how well the different impeller stages perform under various conditions, and is off key importance when it comes to predicting the pump performance. How these multipliers are developed is given in section 5.2. As mentioned in 5.2, the two-phase multipliers is dependent on GVF, density ratio, and flow rate, $f_{\Psi}(\alpha, \rho^*, q^*)$.

Several two-phase multiplier sets can be generated by running tests with various GVFs, density ratios, and flows. The current tests comes in short when it comes to various density ratios. As the system pressure was kept relatively constant, the number of two-phase multiplier sets for different density ratios are limited. In order to develop a sufficient number of two-phase multiplier sets, the system pressure should be varied, creating various density ratios at the pump suction. The current test loop is the main restriction when it comes to the loops ability to handle various density ratios. The test loop need to be reinforced, in order to withstand greater system pressures, making a greater tolerance for a larger variation in density ratios. The current test data, only contain one density ratio for each flow. When the test loop has been reinforced, it will be possible to make two-phase multipliers at various density ratio at a given flow. Other fluid mediums should also be considered. Gases with higher molecular weight (such as CO_2) and diesel as liquid could make it easier to vary the density ratio.

The performance model follows the steps presented in section 5.3, and works its way through the pump stage by stage. The input data, does therefore have to be developed for the different stages. The current test setup consists of two stages with mixed flow impellers and one gas-tolerant radial impeller. It is therefore important that it is developed two sets of input data, one for each impeller type. With the pressure measurement obtained between each point, the single phase and two-phase work coefficient, and thus the two-phase work factor, can be generated. The generation of the two-phase efficiency factor, however, requires the stage power consumption. No data is to this day available for the stage power consumption. Tests on a single stage pump must be conducted, in order to isolate the stage power consumption. Understanding the impact of mechanical seals and leakages is some of the challenges met when it comes to improving the impeller input data for power consumption. A

single stage test with a mixed flow impeller is scheduled and is expected to give valuable data about the mixed flow impeller performance, power consumption, and efficiency. This will also help to improve the single phase performance data which will be used by the affinity law.

7.2 Validation

When the single-stage test results are available, the two-phase multipliers can be developed and input files to the performance prediction model can be updated. To validate the performance prediction model, the prediction need to be compared with the test results. If the validation show satisfactory results, the prediction model can be used to predict the pump performance of new pump configurations. The prediction model can be validated for the pressure difference/head, power consumption, and efficiency.

The way forward will be to update the input files, making the two-phase multipliers dependent on gas volume fraction, density ratio, and flow. The prediction model itself needs to be updated with a method for calculating the efficiency based on the two-phase efficiency factor instead of the power consumption reduction factor.

8 Conclusion

A literature study has been conducted in order to find revised analytical models that can improve the current performance prediction model developed by Aker Solutions. Most of the research done on this field has been of an empirical nature, resulting in prediction models with empirical correlations just valid for a specific pump with a specific hydraulic design. The way forward will be to increase the effort on computational fluid dynamics in order to increase the knowledge of the fundamental principles involved in multiphase pumping. Experimental data alone give uncertainties about which principles affecting the pump performance. Visualization along with experiments gives a new dimension to the knowledge buildup which is crucial in order to develop an accurate performance prediction model.

Single phase and two-phase tests have been conducted on Aker Solutions' HybridBooster. The tests develops the pump performance characteristics for single phase operation as well as for two-phase operation at various gas volume fractions. The tests are important part of the development of the performance prediction model, where test results are used to develop the input data required by the prediction model. Essential tests were postponed and needs to be conducted before the prediction model can be validated. The tests shows promising results for the HybridBooster. The pump were able to operate at a wide range of GVFs and volume flows. The test loop, however, showed to be the limiting factor, which had a relatively low system pressure limit.

Many of the simplifications in the current performance prediction model is expected to be invalid when predicting real condition operation of the multiphase pump. More research has to be conducted on equations of state, thermodynamic modeling, and viscosity models in order to accurately predict the pump performance for other fluids than air and water under real conditions. The two-phase multipliers in the current performance prediction model was not dependent on flow rate. The two-phase multipliers has to be sorted with respect to density ratio, gas volume fraction, and for the specific flow rate, in order to accurately predict the performance at the specific flow rate of interest. The performance pre-

diction model work it's way through the pump stage by stage, so further testing with an one stage impeller is required in order to develop the input data for the prediction model.

References

- [1] Christian Abellsson. *Hybrid Pump Performance Prediction Model*.
- [2] Christian Abellsson. Test procedure pump prototype hybrid jip 3.1. 10001634279-PDC-000, 2012.
- [3] Lars Eirik Bakken. Centrifugal pumps. Lecture note, TEP4195.
- [4] O. Bratland. *Pipe Flow 2 Multi-phase Flow Assurance*. 2010.
- [5] C.E. Brennen. *Fundamentals of multiphase flow*. Cambridge University Press, 2005.
- [6] Roberto Cirilo. *Air-water flow through electric submersible pumps*. PhD thesis, University of Tulsa, Department of Petroleum Engineering, 1998.
- [7] J.F. Gülich. *Centrifugal Pumps*. Springer, 2008.
- [8] Øyvind Hundseid. *Evaluation of Performance Models for Wet Gas Compressors*. PhD thesis, Norwegian University of Science and Technology, 2008.
- [9] Halfdan Knudsen. Multibooster performance. Project Thesis.
- [10] Halfdan Knudsen. Multiphase performance validations. Master's Thesis.
- [11] James Edward Korenchan. *Application of analytical centrifugal-pump performance models in two-phase flow*. PhD thesis, Massachusetts Institute of Technology, 1984.
- [12] James Lea and JL Bearden. Effect of gaseous fluids on submersible pump performance. *Journal of Petroleum Technology*, 34(12):2922–2930, 1982.
- [13] Rui Pessoa and Mauricio Prado. Two-phase flow performance for electrical submersible pump stages. *Old Production & Facilities*, 18(1):13–27, 2003.
- [14] Rune Mode Ramberg. *Multiphase Pump Performance Modelling*. Norwegian University, 2007.

- [15] J.M. Schultz. The polytropic analysis of centrifugal compressors. *Journal of Engineering for Power*, 84:69, 1962.
- [16] David Gordon Wilson, T Chan, and J Manzano-Ruiz. Analytical models and experimental studies of centrifugal-pump performance in two-phase flow.[pwr]. Technical report, Massachusetts Inst. of Tech., Cambridge (USA). Dept. of Mechanical Engineering, 1979.
- [17] Desheng Zhou and Rajesh Sachdeva. Simple model of electric submersible pump in gassy well. *Journal of Petroleum Science and Engineering*, 70(3):204–213, 2010.

A Equations

$$Y_{iso,SPL} = \frac{p_2 - p_1}{\rho_{liq}} \quad (\text{A.1})$$

$$Y_{iso,TP} = (1 - x) \frac{p_2 - p_1}{\rho_{liq}} + xRT \ln \frac{p_2}{p_1} = f_{\Psi} \Psi_{SPL} z_{st} \frac{u_2^2}{2} \quad (\text{A.2})$$

$$H_{SPL} = \frac{Y_{SPL}}{g} \quad (\text{A.3})$$

$$H_{TP} = \frac{Y_{TP}}{g} \quad (\text{A.4})$$

$$\Psi_{SPL} = \frac{2Y_{SPL}}{z_{st}u_2^2} \quad (\text{A.5})$$

$$\Psi_{TP} = \frac{2Y_{iso,TP}}{z_{st}u_2^2} \quad (\text{A.6})$$

$$f_{\Psi} = \frac{\Psi_{TP}}{\Psi_{SPL}} \quad (\text{A.7})$$

$$\eta_{TP} = \frac{P_u}{P} = \frac{\dot{m}Y_{iso,TP}}{P} \quad (\text{A.8})$$

$$\eta_{SPL} = \frac{P_u}{P} = \frac{\dot{m}Y_{iso,SPL}}{P} \quad (\text{A.9})$$

$$f_{\eta} = \frac{\eta_{TP}}{\eta_{SPL}} \quad (\text{A.10})$$

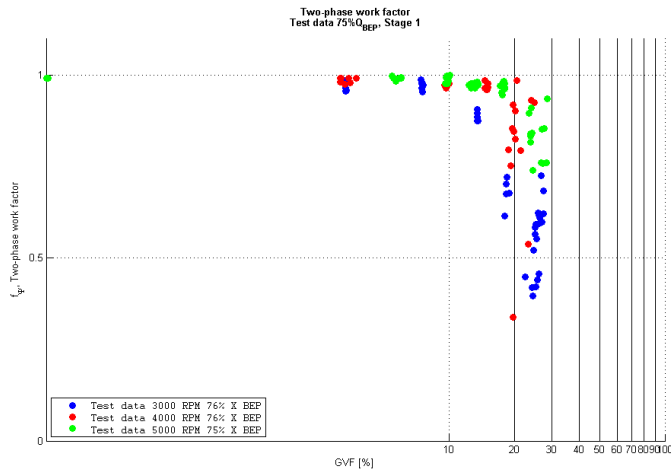
B Two-phase work factor sorted for q^* 

Figure B.1: The two-phase work factor for different rotational speeds at 75% Q_{BEP} .

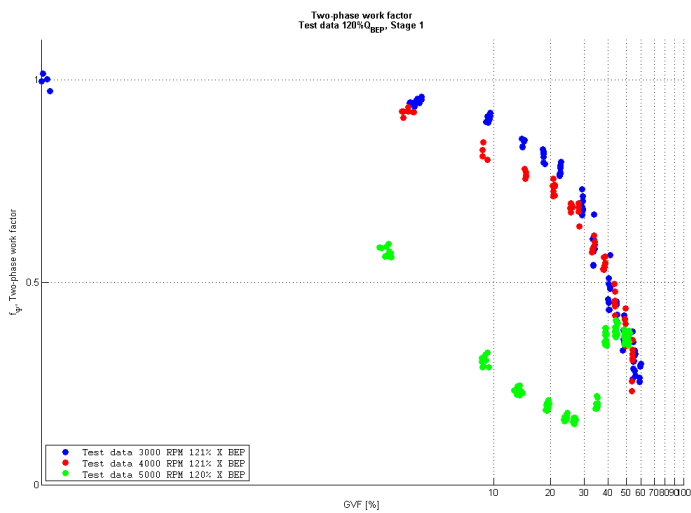


Figure B.2: The two-phase work factor for different rotational speeds at 120% Q_{BEP} .

C Test mode 2 results 3000 and 5000 rpm

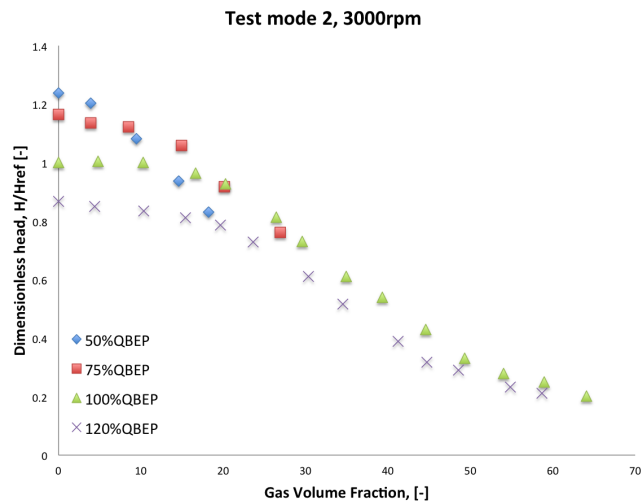


Figure C.1: Pump performance at 3000 *rpm* for different flow with varying GVF.

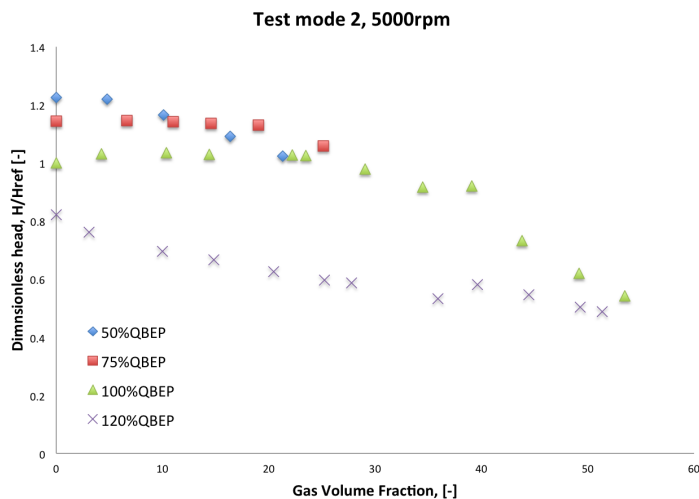


Figure C.2: Pump performance at 5000 *rpm* for different flow with varying GVF.

D Test mode 3 pump performance

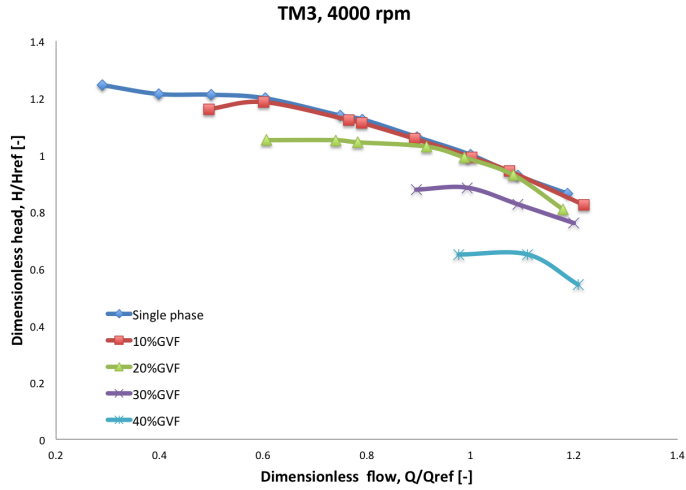


Figure D.1: Pump performance at 4000 rpm for different GVF with varying volume flow.

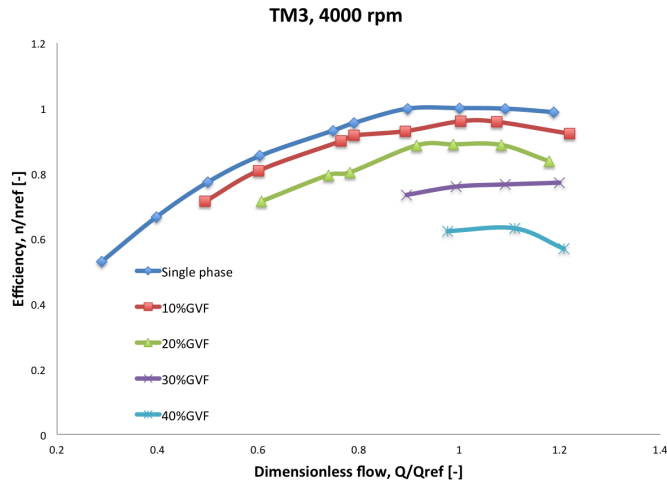


Figure D.2: Pump efficiency at 4000 rpm for different GVF with varying flow.

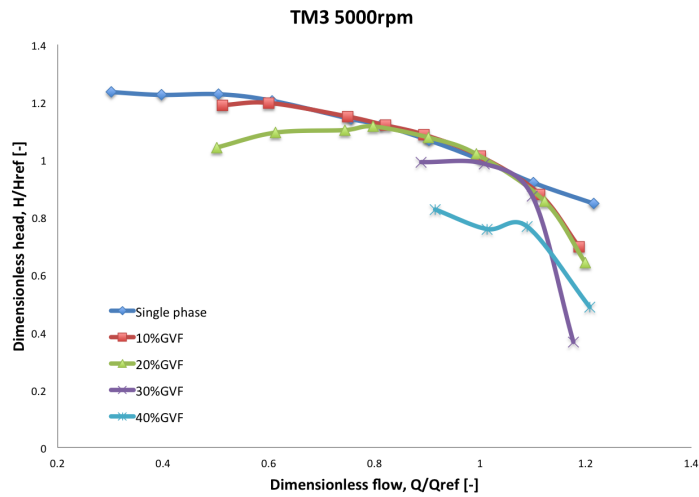


Figure D.3: Pump performance at 5000 *rpm* for different GVF with varying volume flow.

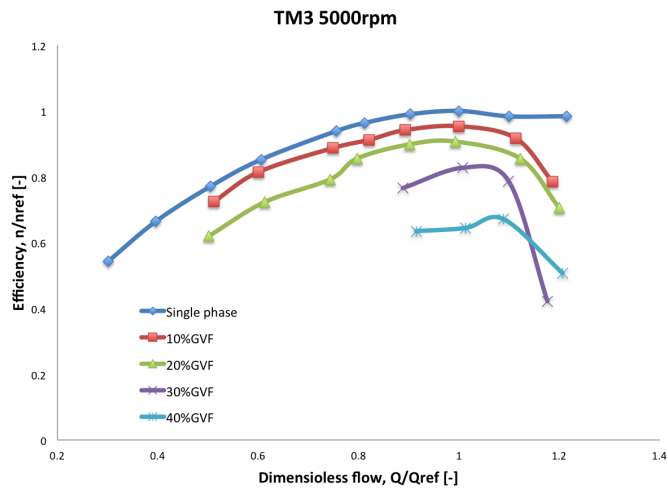


Figure D.4: Pump efficiency at 5000 *rpm* for different GVF with varying flow.