



Norwegian University of  
Science and Technology

# A Process from Conceptual Design to Manufacturable Parts in Low Volume Production

Redesigning conceptual designs to  
manufacturable parts through manufacturing  
processes and manufacturability theory.

**Andre Haig Johnsen**

Mechanical Engineering

Submission date: June 2018

Supervisor: Knut Einar Aasland, MTP

Norwegian University of Science and Technology  
Department of Mechanical and Industrial Engineering





MASTER THESIS 2018

**A Process from Conceptual Design  
to Manufacturable Parts in  
Low Volume Production**

Redesigning conceptual designs to manufacturable parts through  
manufacturing processes and manufacturability theory.

ANDRE HAIG JOHNSEN



Department of Mechanical Engineering  
Exero Technologies  
NORWEGIAN UNIVERSITY OF SCIENCE AND TECHNOLOGY  
Trondheim, Norway 2018

A Process from Conceptual Design to Manufacturable Parts in Low Volume Production

Redesigning conceptual designs to manufacturable parts through manufacturing processes and manufacturability theory.

ANDRE HAIG JOHNSEN

© ANDRE HAIG JOHNSEN, 2017.

Supervisor: Knut Aasland, Department of Mechanical Engineering

Examiner: Knut Aasland, Department of Mechanical Engineering

Master Thesis 2018

Department of Mechanical Engineering

Exero Technologies

Norwegian University of Science and Technology

Hoegskoleringen 1, 7491 Trondheim, Norway

Telephone +47 73 59 50 00

Cover: Sketch design and manufacturable 3D model of Spike™.

Typeset in L<sup>A</sup>T<sub>E</sub>X

Trondheim, Norway 2018

# Abstract

Product development methodologies take innovative ideas from design sketches to 3D models to physical products. The IPM model executes this process through generating conceptual designs of a product and manufacturing it. Often a conceptual design's manufacturability is not taken into consideration during the design process. This can lead to an expensive reiteration of making the conceptual designs manufacturable.

This master thesis follows the reiteration of a conceptual design process for an assistive sports equipment product in a low volume production market. The product has been conceptually designed without consideration for manufacturability. This thesis will show how a product can be redesigned for manufacturability through selection of manufacturing processes and design for manufacturability theory. This thesis also includes taking a product to the final stage of setting up manufacturing partners.

Redesigning for manufacturability proved to lower the cost and improve overall design of the product. Implementing manufacturability is as important for low volume production as for high volume production since the design changes are rarer. This thesis results in a manufacturable design of an assistive sports equipment and manufacturing partners. Results proved that the implementation of manufacturability and selection of manufacturing process should occur between the design sketch and conceptual design phase.

**Keywords:** design, manufacturability, manufacturing process, quotation, manufacturers, guangzhou, exero, spike, assistive



# Acknowledgements

First and foremost, I have to thank my research supervisor **Mr Knut Aasland**. His assistance and openness to the project has allowed me to shape this thesis as I see fit. Allowing me to go to China for my research project changed the contents of the project for the better.

I would also like to thank the **Department of Production and Materials at the Norwegian University of Science and Technology** for sending me to Beijing, China for a my research project. Thank you to the **Department of Mechanical Engineering at Tsinghua University** for accepting me.

I would also like to show gratitude to the following:

**Exero Technologies**, Company

**Dr Jingshan Zhao 赵景山**, at Tsinghua University

**Hao Han 鲲鹏**, CTO at ANNE

**Zachary Lam 林泳耀**, CEO of Schniff

**Franny Fan 范艳芳**, Sales at 3a Prototyping

**Candice Xiao 坎迪丝**, Sales at SuNPe Manufacturing

**Wilson Lin 威尔逊**, Sales at APT Molding

**Arman Echtebrush Majedi**, Designer

**Lasse Rox Farstad**, Designer

**Benjamin Kleppur**, Office Space

**Afl Daae Jonassen**, Mentor

**Petter Liljengun**, Mentor

**Oscar Fæff Flo**, Consultant

Andre Haig Johnsen, Trondheim, 30.05.2018



# Preface

This master thesis is written in collaboration with Exero Technologies AS. The purpose of the master thesis is to give an overview of how design for manufacturability theory and knowledge of manufacturing processes can be implemented in a design process of a product in low volume production. The goal of the project is to inspire the product developers at Exero Technologies, as well as others, to implement manufacturability practices earlier and more frequently in design stages of a product.

Trondheim, June 2018

---

Andre Haig Johnsen





# Contents

<b>List of Figures</b>	<b>XIV</b>
<b>List of Tables</b>	<b>XVI</b>
<b>1 Introduction</b>	<b>1</b>
1.1 Characteristics of designing for manufacturability . . . . .	1
1.2 Characteristics of developing assistive sports equipment . . . . .	2
1.3 Exero Technologies . . . . .	3
1.3.1 History . . . . .	3
1.3.2 Prototype Beta . . . . .	4
1.3.2.1 Steering System . . . . .	5
1.3.2.2 Main Frame Profile . . . . .	6
1.3.2.3 Knee and Calf Supports . . . . .	6
1.3.2.4 Seat . . . . .	7
1.3.2.5 Testing . . . . .	8
1.3.3 Spike . . . . .	8
1.4 Market . . . . .	9
1.5 Research Questions . . . . .	9
1.6 Scope . . . . .	10
<b>2 Theory</b>	<b>11</b>
2.1 Design for Manufacturability (DFM) . . . . .	11
2.1.1 Reduce the total number of parts . . . . .	12
2.1.2 Develop a modular design . . . . .	12
2.1.3 Use of standard components . . . . .	13
2.1.4 Design parts to be multi-functional . . . . .	13
2.2 Manufacturing Processes . . . . .	13
2.2.1 Extrusion . . . . .	14
2.2.1.1 Hot extrusion . . . . .	14
2.2.1.2 Cold extrusion . . . . .	15
2.2.2 Die Casting . . . . .	15
2.2.3 CNC Milling . . . . .	17

2.2.4	Sheet metal . . . . .	18
2.2.5	Injection molding . . . . .	19
2.2.6	Vacuum casting with PUR (Polyurethane) materials . . . . .	20
2.2.7	Vacuum forming . . . . .	21
2.2.8	Surface Finish . . . . .	22
	2.2.8.1 Mechanical . . . . .	22
	2.2.8.2 Electrochemical (Anodizing) . . . . .	23
	2.2.8.3 Powder coating . . . . .	24
2.3	Materials . . . . .	24
	2.3.1 AL 6061-T6 . . . . .	24
	2.3.2 Acrylonitrile butadiene styrene (ABS) . . . . .	24
	2.3.3 High Impact Polystyrene (HIPS) . . . . .	24
	2.3.4 PUR 8051 (Polyurethane) . . . . .	25
2.4	Manufacturers . . . . .	25
	2.4.1 SuNPe Manufacturing . . . . .	26
	2.4.2 APT Molding . . . . .	26
2.5	Bill of Materials (BOM) and Quotations . . . . .	26
2.6	Product Development . . . . .	27
	2.6.1 IPM model . . . . .	27
	2.6.2 MVP - Minimum Viable Product . . . . .	27
<b>3</b>	<b>Method</b>	<b>29</b>
	3.1 Sketch Design . . . . .	30
	3.2 Main Frame Profile . . . . .	32
	3.2.1 Conceptual design . . . . .	32
	3.2.2 Manufacturability . . . . .	33
	3.2.3 Design for manufacturability . . . . .	36
	3.2.4 Manufacturable part . . . . .	38
	3.3 Knee and Calf Supports . . . . .	40
	3.3.1 Conceptual design . . . . .	40
	3.3.2 Manufacturability . . . . .	42
	3.3.3 Design for manufacturability . . . . .	44
	3.3.4 Manufacturable part . . . . .	46
	3.4 Seat Post . . . . .	48
	3.4.1 Conceptual design . . . . .	48
	3.4.2 Manufacturability . . . . .	49
	3.4.3 Design for manufacturability . . . . .	50
	3.4.4 Manufacturable part . . . . .	53
<b>4</b>	<b>Results</b>	<b>55</b>
	4.1 Main Frame Profile . . . . .	55
	4.1.1 Profile End . . . . .	56
	4.2 Knee and Calf Supports . . . . .	57
	4.3 Seat Post and Arm . . . . .	58
<b>5</b>	<b>Discussion</b>	<b>59</b>

<b>6</b>	<b>Conclusion</b>	<b>62</b>
6.1	Further Research . . . . .	63
	<b>Bibliography</b>	<b>64</b>
	<b>Appendix</b>	<b>I</b>
<b>A</b>	<b>Bills of Materials: Spike</b>	<b>II</b>
A.1	Polymer Parts . . . . .	II
A.2	All parts . . . . .	IV
<b>B</b>	<b>Quotations</b>	<b>VI</b>
B.1	Main Frame Profile . . . . .	VI
B.2	Profile End . . . . .	VIII
B.3	Knee and Calf Supports . . . . .	X
B.4	Knee and Calf Support Conceptual Design CNC Milling . . . . .	XIII
B.5	Knee and Calf Support Conceptual Design Vacuum Casting . . . . .	XIX
B.6	Seat Arm and Post . . . . .	XXV
<b>C</b>	<b>Production Drawings</b>	<b>XLVII</b>
C.1	Main Frame Profile . . . . .	XLVII
C.2	Profile End . . . . .	XLIX
<b>D</b>	<b>Data Sheets</b>	<b>LI</b>
D.1	Aluminum 6061-T6 . . . . .	LI
D.2	Acrylonitrile butadiene styrene (ABS) . . . . .	LIV
D.3	Polyurethane (PUR) . . . . .	LVII
<b>E</b>	<b>Master Thesis Research Project</b>	<b>LX</b>

# List of Figures

1.1	Exero Technologies logo . . . . .	3
1.2	Variants of cross-country sit-skiing . . . . .	3
1.3	Prototype Alpha: The first off-road cross-country sit-ski prototype. . . . .	4
1.4	Prototype Beta . . . . .	5
1.5	Prototype Beta; Steering System . . . . .	6
1.6	Prototype Beta; Main Frame Profile . . . . .	6
1.7	Prototype Beta; Knee and Calf Supports . . . . .	7
1.8	Prototype Beta; Seat Post . . . . .	7
1.9	Prototype Beta; Seat . . . . .	7
1.10	Espen Aksnes testing Prototype Beta . . . . .	8
2.1	Extrusion process . . . . .	14
2.2	Extrusion types . . . . .	14
2.3	Plastic extrusion process . . . . .	15
2.4	Die casting process (cold) . . . . .	16
2.5	Hurco 5-axis milling machine . . . . .	17
2.6	Complex geometric part . . . . .	18
2.7	Sheet metal laser cut and bent . . . . .	19
2.8	Injection moulding process . . . . .	20
2.9	Silicone mold . . . . .	21
2.10	Vacuum forming process . . . . .	22
2.11	Anodizing process . . . . .	23
2.12	Guangdong province . . . . .	25
2.13	SuNPe Manufacturing logo . . . . .	26
2.14	APT Molding logo . . . . .	26
3.1	Spike sketch design; Isometric view . . . . .	30
3.2	Spike sketch design; Isometric view 2 . . . . .	31
3.3	Spike sketch design; Parts . . . . .	31
3.4	"Tube in tube" mechanism . . . . .	32
3.5	Conceptual Design; Main frame profile . . . . .	33
3.6	"Tube in tube" sleeve . . . . .	35

---

3.7	Main frame profile cross section . . . . .	37
3.8	Slider and T-lock . . . . .	37
3.9	Slider and T-lock exploded view . . . . .	37
3.10	Profile end . . . . .	38
3.11	Manufacturable Part; Main frame profile, profile ends and sliders . .	39
3.12	Manufacturable Part; Exploded view . . . . .	39
3.13	Conceptual Design; Knee support . . . . .	41
3.14	Conceptual Design; Calf support . . . . .	41
3.15	Partial assembly of calf support, support brackets, base plate and slider . . . . .	42
3.16	Knee support base design . . . . .	45
3.17	Calf support base design . . . . .	45
3.18	Base slots . . . . .	45
3.19	Base plate . . . . .	46
3.20	Manufacturable Part; Knee support . . . . .	47
3.21	Manufacturable Part; Calf support . . . . .	47
3.22	Knee support and slider assembly . . . . .	47
3.23	Conceptual Design; Seat post . . . . .	49
3.24	Seat arm and post design . . . . .	51
3.25	Seat arm design . . . . .	52
3.26	Seat post design . . . . .	53
3.27	Manufacturable Design; Seat post and arm . . . . .	54
3.28	Manufacturable Design; Spike . . . . .	54

# List of Tables

3.1	Main Frame Profile Requirements . . . . .	32
3.2	Aluminum Tubing Standard Dimensions . . . . .	34
3.3	"Tube in Tube" Combinations . . . . .	34
3.4	Die Casting Tooling Prices . . . . .	36
3.5	Extrusion Tooling Prices . . . . .	36
3.6	Knee and Calf Support Requirements . . . . .	40
3.7	Supports Manufacturing Process Costs . . . . .	44
3.8	Seat Post Requirements . . . . .	48
4.1	Main Frame Profile; ATP Molding Quotation . . . . .	56
4.2	Profile End; ATP Molding Quotation . . . . .	56
4.3	Knee Support; SunPe Quotation . . . . .	57
4.4	Calf Support; SunPe Quotation . . . . .	57
4.5	Seat Post Quotation . . . . .	58
4.6	Seat Arm Quotation . . . . .	58

## Abbreviations and Definitions

NTNU = Norwegian University for Science and Technology

DFM = Design for Manufacturability

CAD = Computer Aided Design

CNC = Computer Numerical Control

CAM = Computer Aided Machining

BOM = Bill of Materials

MVP = Minimum Viable Product

Lead time = Time to manufacture

Proof of Concept = A functional prototype that proves the concept of a design





# 1

## Introduction

This master thesis is a product development case written for the Department of Mechanical and Industrial Engineering at NTNU. The author is a MSc student at NTNU Mechanical Engineering.

Based on literature review, own experience and research the author will identify and describe challenges evolving a product from a *Conceptual Design* to a *Manufacturable Product*, and this within a *low volume production* market. These challenges are shown by following the final stages of the product development process for a product from the authors own assistive technology start-up company, Exero Technologies. The product was originally designed without consideration for manufacturability, but will be redesigned based on manufacturing theory. This is done with the aim to better understand the final stages of product development methodologies and what influence manufacturing processes have on conceptual designs.

### 1.1 Characteristics of designing for manufacturability

Product development methodologies are renowned processes for developing new products. There are many different methodologies such as the IDEO model, BAH model, Stage-Gate model, IPM model etc. Each methodology presents it's own way of iterating a development process to get the most functional and cost effective design. One point they all have in common is the last development stage, commonly referred to as "Production Start-Up (IPM)", "Full-Production (Stage-Gate)" "Commercialization (BAH)" or "Implementation (IDEO)". Though these stages have different names they all have the same content; "Find manufacturing processes, manufacturers and finalize product for market" This sentiment implies taking the concept design and prototype and manufacturing it in a cost effective. This can be done by designing for manufacturability (DFM).

Boothroyd and Dewhurst were pioneers in bringing to light the importance of DFM in their "Design for Manufacture" module from 1985 [1]. They define DFM as:

*“As the basis for concurrent engineering studies to provide guidance to the design team in simplifying the product structure to reduce manufacturing and assembly costs, and to quantify the improvements”*

(Boothroyd and Dewhurst, 2011)

*“As a should-cost tool to help control the costs and to help negotiate suppliers contracts”*

(Boothroyd and Dewhurst, 2011)

Implementing DFM practices could be even more important when the production quantities are small rather than high [2]. This is because reconsideration of the initial design is usually not carried out for low-volume production. Often the prototype is not built on stock items and will become the production model, therefore, it is important to do it right the first time.

Design engineers and manufacturing engineers must work together. Commonly the attitude of design engineers has been the "over the wall approach". This implies design engineers throwing designs over the wall to the manufacturing engineers, who have to fix the various manufacturing problems because they were not involved in the design phase. Including manufacturing engineers from the design phase is one means to overcoming this problem. Traditionally, it was expected that engineering students have workshop courses which gave awareness around manufacturing processes. Unfortunately, since the 1980's workshop courses have disappeared from university curricula. Currently, engineering students have little knowledge of manufacturing processes and how to implement manufacturing process requirements into their designs.

## 1.2 Characteristics of developing assistive sports equipment

Developing assistive sports equipment leads to some difficulties. Rarely do users have identical injuries which implies different body shapes and capabilities. Users might have needs and preferences specific to their condition which makes it necessary to imply as much adaptability to the design as possible.

As the potential number of users is limited, so is the production quantity. Producing assistive sports technology is a very low volume and specified market. To achieve good returns, engineers must design innovative, reliable and exceptional products and most importantly at a low cost. These goals often contradict themselves making it difficult to achieve.

## 1.3 Exero Technologies

Exero Technologies is a start-up company originating from NTNU's School of Entrepreneurship, see figure 1.1. The company was founded February 2nd, 2017 and aims to develop and market the next centuries assistive sports equipment. The company consists of 5 people, of which all are founders. Three of the founders are students at NTNU's School of Entrepreneurship and two of the founders are students at NTNU's Department of Product Development and Materials. The author of this thesis is one of the founders.



**Figure 1.1:** Exero Technologies logo

*Source: Exerotech [3]*

### 1.3.1 History

Cross-country sit-skiing is a cross-country variant for people with disabilities in the lower part of their body. The user sits in a chair supported with a suspension over a pair of skis that rides in a track, see figure 1.2a. The user propels themselves with ski poles. Cross-country sit-skiing is a sport for exercise, entertainment and competition. The activity is classified as a discipline in the Paralympics.



(a) Cross-country sit-skiing. *Source: Boston Globe [4]*



(b) Cross-country sit-skiing on pavement. *Source: NRK [5]*

**Figure 1.2:** Variants of cross-country sit-skiing

An ongoing problem for this sport is the impractical training during the summer. By switching to roller skis and rolling on pavement, no modification is made in order to maneuver the sit-ski, see figure 1.2b. There is much less friction between

## 1. Introduction

---

the skis and pavement than during the winter between skis and snow. Therefore users must strenuously lift their torso to toggle the sit-ski in the desired direction.

In the summer of 2016 a bachelor thesis out of Norway's University for Science and Technology (NTNU), "Steering system for cross-country sit-skis", designed a Proof of Concept solution for the maneuverability problem; Prototype *Alpha*. They designed an off-snow cross-country sit-ski that was able to maneuver on pavement, see figure 1.3.



**Figure 1.3:** Prototype Alpha: The first off-road cross-country sit-ski prototype.  
*Source: Steering system for cross-country sit-skis [6]*

The team behind the bachelor thesis found much potential in their Proof of Concept prototype as this could be an *exercise equipment for all people with disabilities*, not just for sit-skiers during the summer. Therefore, they created the start-up company "Exero Technologies" at NTNU's School of Entrepreneurship and made a new Prototype *Beta*.

### 1.3.2 Prototype Beta

Prototype Beta was designed in January 2017 as an Minimum Viable Product (MVP) to provide feedback from customers, see chapter 2.6.2. It was designed and manufactured locally at a workshop in Trondheim, Norway. The design extended the functionality requirements from Prototype Alpha and satisfied other customer features such as comfort, lightweight, handling and braking.

A remodelled seating was mounted onto a main frame profile with an improved steering system and brakes attached at each end, see figure 1.4. The prototype can be divided into five main components; **steering system**, **main frame profile**,

**knee and calf supports, seat post and seat.** The innovation by Exero Technologies is not in the design of the main components themselves, but assembling them, optimizing their use case and meeting the demands from end users.



**Figure 1.4:** Prototype Beta  
*Source: Exerotech Database [7]*

### 1.3.2.1 Steering System

The steering system is originally used by mountain boards and are known as trucks, see figure 1.5. The trucks have one spring and damper on each side of a rotational center. These springs can be individually adjusted allowing the user to move their center of gravity. This is unbelievably useful for users with unsymmetrical weight distribution. The steering mechanism implemented in the trucks is defined by the magnitude of the side-ways angle of the users upper body. Keeping the upper body in straight upward position while propelling with ski-poles, allows the sit-ski to move straight. Tilting to one side or the other during propulsion will steer the ski-ski in the tilted direction. 8-inch tires are set up with hydraulic brakes on each side of the two front wheels. The manual braking lever is mounted in the middle of the knee support.



**Figure 1.5:** Prototype Beta; Steering System

*Source: Exerotech Database [7]*

### 1.3.2.2 Main Frame Profile

The main frame profile is the root of the Spike. It connects the seating, knee and calf supports to the steering system, see figure 1.6. The properties of importance are strength, weight and adjustments. The frame is made of 25x25x2.5mm 6061-T6 aluminum profiles. There are vertical and horizontal adjustment holes along the frame for the knee and calf supports.



**Figure 1.6:** Prototype Beta; Main Frame Profile

*Source: Exerotech Database [7]*

### 1.3.2.3 Knee and Calf Supports

Knee and calf supports are placed parallel to each other along the main frame profile, see figure 1.7. They can individually slide along the frame or be completely detached. They are made by casting plastic and are layered with closed-cell foams for cushioning.



**Figure 1.7:** Prototype Beta; Knee and Calf Supports  
*Source: Exerotech Database [7]*



**Figure 1.8:** Prototype Beta; Seat Post  
*Source: Exerotech Database [7]*

#### 1.3.2.4 Seat

The seat comes in three sizes and is made in a similar fashion as the supports with closed-cell foaming for cushioning, see figure 1.9. The seat is excluded from this thesis.



**Figure 1.9:** Prototype Beta; Seat  
*Source: Exerotech Database [7]*



## 1. Introduction

---

All supports have belt straps to hold the body in place. All adjustments are made through un-screwing M6 screws and bolts on the main frame profile and seat and re-screwing them in new positions.

### 1.3.2.5 Testing

From January 2017 to November 2017 Prototype Beta had been tested by 60 potential users with paraplegia, see figure 1.10. This type of user-oriented testing resulted in a product that several users requested.



**Figure 1.10:** Espen Aksnes testing Prototype Beta  
*Source: Exerotech Database [3]*

### 1.3.3 Spike

Based on user and community feedback Exero are making an official product they call **Spike** based off Prototype Beta. Exero aim to launch the product in the summer of 2018. Spike has been designed through product development methods and is currently designed on a conceptual level *without consideration for manufacturing*. For the Spike to be ready for launch the design must be redesigned for manufacturability and manufacturing partners must be obtained.



## 1.4 Market

Exero Technologies and their official product Spike is in a low volume production market. Market research performed by Exero shows that people with spinal cord injuries, amputees, cerebral palsy, polio or other muscle diseases are in the most need for new solutions within adaptive sports and are able to use Spike. These disabilities account for 3,2 million potential users in the US and Scandinavia. This is Exero's target market the next five years due to the market size and willingness to pay. Exero's beachhead market is considered to be Scandinavia, due to its unique welfare services, with approximately 50 000 potential users.

This thesis focuses on production and sales for 2018 and 2019. In this time frame Exero estimate to sell **15 units** in Norway. The market in this thesis will therefore be based in Norway and around these sale estimates.

## 1.5 Research Questions

The purpose of this thesis is to help others understand the process of altering a conceptual design to manufacturable parts, specifically in low volume production. This is done by presenting the process in which an assistive sports equipment Spike was designed for manufacturability. This thesis will attempt to answer the following research questions;

**R1;** When to implement manufacturability into a design?

**R2;** How do manufacturing process requirements affect the design of a product?

**R3;** How to choose correct manufacturing processes for a part?

**R4;** How does low volume production affect the selection of manufacturing processes?

## 1.6 Scope

This master thesis focuses on the process of designing manufacturable parts related to the start-up company Exero Technologies. The process follows a real product development case of Spike, but the development process is viewed in an underlying matter. Spike has been designed on a conceptual level without consideration of manufacturability. This thesis will present challenges discovered during designing for manufacturability and describe the process of solving them.

Data and information regarding Exero Technologies is self-reported. Theory in this field is gathered through search engines for scientific articles, tangible scientific articles and on site user-experience.

The first part of this thesis reviews relevant theory. The following chapter describes how the author has conducted his research on the process from conceptual design to manufacturable parts. The process is discussed and concluded to the extent of the study's limitation. Lastly, further work is suggested by the author.

# 2

## Theory

This chapter presents relevant theory used in chapter 3. This includes theory on designing for manufacturability, manufacturing processes, materials, manufacturers, manufacturer communication and product development processes.

### 2.1 Design for Manufacturability (DFM)

Design for Manufacturability is a crucial and often skipped product development step commonly between the "Concept Design" and "Detail Design" phases. DFM is the engineering practice of designing products in such a way that makes them easy and economic to manufacture. A part can be 3D-modelled and simulated to work on a conceptual and functional level, but might be difficult or impossible to manufacture due to certain manufacturing requirements. DFM involves changing a products design in order to facilitate the manufacturing process and lower manufacturing costs. This design change must occur without damaging the functional integrity of the product.

An integral part of designing for manufacturability is the early selection of material, manufacturing process and the combination of the two. In order to be of real design value, the selection of process/material combination is based on information such as [2];

- Product life volume
- Permissible tooling expenditure levels
- Possible part shape categories and complexity levels
- Service and environment requirements
- Appearance factors
- Accuracy factors

For many products the design and manufacturing process are so intimately related

that the product design must anticipate a manufacturing process as a starting point. Many products cannot be defined without a consideration of processing. A rough economical evaluation between competing processes can be made early based on conceptual design criteria. This gives an economical model for the designer. As the product moves from conceptual design to detail design, more accurate cost models can be preformed.

Addressing potential manufacturing problems in the design phase is the least expensive phase to do so. 70% of manufacturing costs of a product are determined by design decisions, with production decisions responsible for only 20% [8]. Certain design principles are structured to help the designer reduce difficulty and cost of manufacturing a part;

### 2.1.1 Reduce the total number of parts

*“The reduction of the number of parts in a product is probably the best opportunity for reducing manufacturing costs. Less parts implies less purchases, inventory, handling, processing time, development time, equipment, engineering time, assembly difficulty, service inspection, testing, etc. In general, it reduces the level of intensity of all activities related to the product during its entire life. A part that does not need to have relative motion with respect to other parts, does not have to be made of a different material, or that would make the assembly or service of other parts extremely difficult or impossible, is an excellent target for elimination. Some approaches to part-count reduction are based on the use of one-piece structures and selection of manufacturing processes such as injection molding, extrusion, precision castings, and powder metallurgy, among others.”* (Chang, 2012 [8])

### 2.1.2 Develop a modular design

Developing a modular design has many benefits such as simplifying assembly, maintenance, service, redesign and adding parts. Modular parts adds versatility to a product update in the redesign process. If a product is thought to be upgraded in the future using standard components, modular based parts will lower the cost of a redesign, especially if the previous tooling can be utilized.

### 2.1.3 Use of standard components

Standard components exist for most items regardless the material. Standards are made when there is a high demand for specific dimensions and shapes of an item, for example in tubing. Circular and square tubes are the most common profiles used in tubing, therefore most manufacturers have pre-made extrusion tooling for different dimensions. This allows a buyer to purchase certain dimensional tubing without having to invest in tooling equipment. This makes standard components less expensive than custom-made components due to high availability and reduced lead times. Furthermore, standard components reliability factors are well ascertained and the supplier need not concern about production schedules. Most manufacturers will present catalogs to their buyers that previews their standard dimensions and stock items. Both buyer and supplier prefer using standard components if it is possible. Purchasing standard components can drastically reduce manufacturing cost, but limits the buyer to develop classic and simple designs, as most standard components are not detailed.

### 2.1.4 Design parts to be multi-functional

Designing a product with multi-functional parts reduces the total number of parts in a design. This is common practice for symmetrical products like scissors or chairs. Other examples of multi-functional parts are parts that act besides their principal function like guiding, aligning, or self-fixturing features to facilitate assembly.

## 2.2 Manufacturing Processes

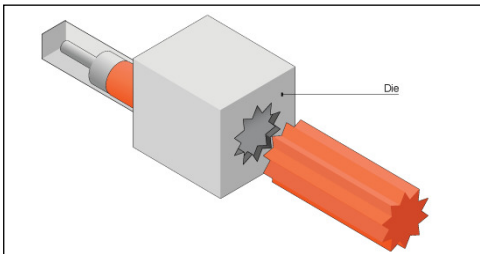
Manufacturing is the production of merchandise for use or sale using labour, tools, machine processing or chemical and biological processing. The term is most commonly applied to industrial production, in which raw materials, components or parts are transformed into finished goods that meet a customer's expectations or specifications [9]. Such finished goods may be sold to customers for the production of other products who then sell them to end users and consumers. The procedure begins with a part design and material specification. These materials are then modified through manufacturing processes to become the required part.

For the metal manufacturing processes this chapter will focus on aluminum, more specifically AL 6061-T6, see chapter 2.3.1. AL 6061-T6 was chosen in the research study of this thesis as the primary metal material, see Appendix E for Master Thesis; Research Project.

### 2.2.1 Extrusion

Extrusion, or extrusion molding is a process used to create objects of a fixed cross-sectional profile. A material is pushed through a die of the desired cross-section, see figure 2.1. The main advantage of this process over other manufacturing processes is its ability to create complex cross-sections. Extrusion can work materials that are brittle, because the material only encounters compressive and shear stresses. Extrusion produces long and thin tubes and tracks with custom profiles, see figure 2.2. It also forms parts with an excellent surface finish. Metals, plastics and ceramics can be extruded, all under different temperatures and environments. Forms of extrusion include: hot, cold, warm, friction and micro extrusion.

Utilizing extrusion in a design requires investing in extrusion tooling. The tooling can take weeks to complete and the price varies in accordance with the complexity of the cross section. Though extrusion tooling can be expensive, a tooling usually last for 50 000 cycles.



**Figure 2.1:** Extrusion process  
*Source: BBC [10]*



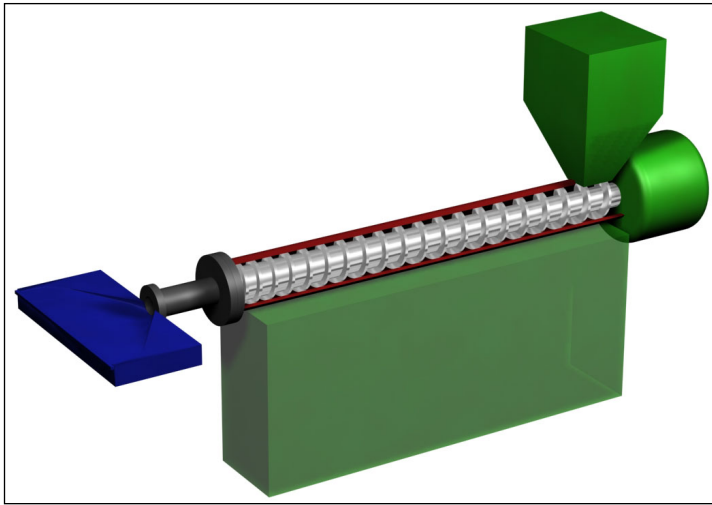
**Figure 2.2:** Extrusion types  
*Source: BBC [10]*

#### 2.2.1.1 Hot extrusion

Hot extrusion is a hot working process always performed at temperatures much higher than the recrystallization temperature of the material. This is to keep the material from work hardening and making it easier to push through the die. Most hot extrusions are done horizontally on large hydraulic presses that can way up to 12,000 metric tons. Pressures range from 30 to 700 MPa, therefore lubrication is required. For lower temperature extrusions oil or graphite can be used as lubrication. Glass powder is used for higher temperature extrusions [11].

Aluminum is the most commonly hot extruded metal, though it can be cold extruded as well. If it is hot extruded it is heated to 300 to 600°C. Aluminum is commonly extruded to profiles, tubing, tracks, frames, rails, mullions and heat sinks [12]. Other commonly hot extruded materials include: magnesium, copper,

steel, titanium, nickel and other refractory alloys. Plastics are also hot extruded, but under lower temperatures and through a different process, see figure 2.3.



**Figure 2.3:** Plastic extrusion process

*Source: Wikimedia [13]*

### 2.2.1.2 Cold extrusion

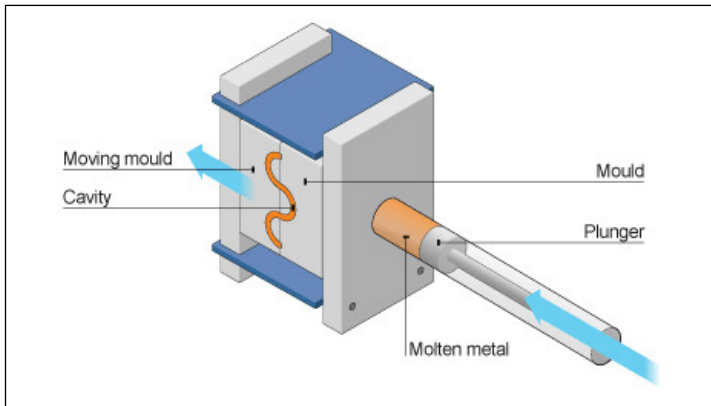
Cold extrusion is a cold working process usually performed at ambient temperatures. For most materials this is below the recrystallization temperature. This allows the material to experience work hardening, also known as strain hardening, which strengthens the metal or polymer by plastic deformation. This strengthening is caused by dislocation movements and dislocation generation within the crystal structure of the material [14].

Other advantages of cold extrusion are the lack of oxidation, closer tolerances, better surface finish, and fast extrusion speeds if the material is subject to hot shortness [11]. Materials that are commonly cold extruded include: lead, tin, aluminum, copper, zirconium, titanium, molybdenum, beryllium, vanadium, niobium, and steel.

## 2.2.2 Die Casting

Die casting is a metal casting process that forces molten metal under high pressure into a mold cavity. The mold cavity is assembled by two hardened steel die/mold

halves. The mold halves are specially machined into unique hollow shapes and assembled by a high pressure clamping unit. One of the dies are stationary and equip with an injection tube. Molten metal is plunged through the injection tube at pressures up to 138 MPa and fill the cavity, see figure 2.4. After the molten metal is injected into the dies, it rapidly cools and solidifies into the final part, called the casting. The cooling time can be estimated from several thermodynamic properties of the metal, the maximum wall thickness of the casting, and the complexity of the die [15]. Once solidified, the casting can be ejected and trimmed of excess material.



**Figure 2.4:** Die casting process (cold)

*Source: BBC [16]*

Most die castings are made from non-ferrous metals such as aluminum, magnesium or zinc. Depending on the type of metal being cast, a hot- or cold-chamber machine is used. Hot chamber machines are used for alloys with low melting temperatures, such as zinc, tin, and lead. Having low melting temperatures allow these alloys to be heated and pumped through the die to the cavity. The temperatures required to melt other alloys with high melting temperatures such as aluminum, brass and magnesium would damage the pumping system. Hence, the molten metal is kept separate from the die casting machine and plunged into the cavity in what is called a cold chamber machine [17].

Die casting is an accurate manufacturing process and is therefore commonly used to produce geometrically complex metal parts. Often a part is cast if the design is too complex for extrusion. The two processes are very similar as they both require an initial investment for the die's and tooling equipment and offer a cheap and repeatable production of custom parts. Other significant advantages over other manufacturing processes are cost savings per part price and overall production, variable wall thickness, tighter tolerances, ability to combine multiple parts, fast production, less material scrap and long tool life.



### 2.2.3 CNC Milling

*“CNC milling is a specific form of computer numerical controlled (CNC) machining. Milling itself is a machining process similar to both drilling and cutting, and able to achieve many of the operations performed by cutting and drilling machines. Like drilling, milling uses a rotating cylindrical cutting tool. However, the cutter in a milling machine is able to move along multiple axes, and can create a variety of shapes, slots and holes. In addition, the work-piece is often moved across the milling tool in different directions, unlike the single axis motion of a drill.”*

(Thomas Net, 2012 [18])

CNC milling devices are the most widely used type of CNC machines. The most advanced machines have 5 axis milling centers, see figure 2.5. They require CAM programming due to the complex geometries involved in the machining process. CNC milling machines are also equip with cutting fluid ejection tubes to cool and smoothen the cutting tool during machining.



**Figure 2.5:** Hurco 5-axis milling machine

Source: Hurco [19]

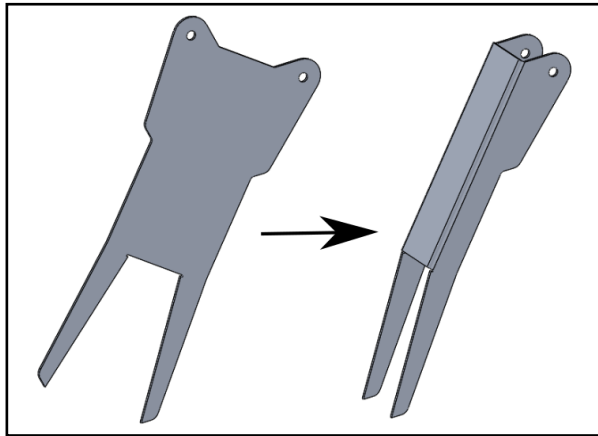


**Figure 2.6:** Complex geometric part  
*Source: American Machinist [20]*

Virtually any type of solid material can be CNC machined if the hardness of the work-piece and rotation of the cutting tool are factored before beginning the milling process. The most common work-piece materials are metals and polymers. These devices are very useful because they are able to produce shapes that would be nearly impossible using manual tooling methods, see figure 2.6.

### 2.2.4 Sheet metal

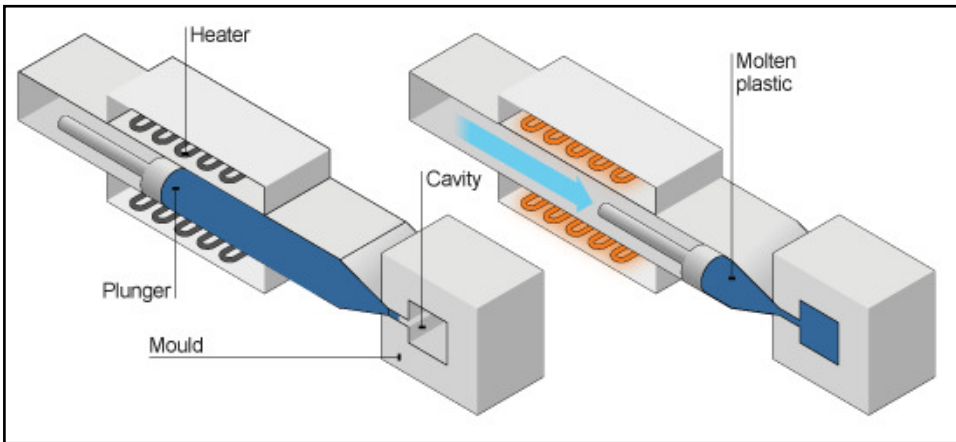
Sheet metal is a thin, flat sheet of industrial processed metal. It is the most fundamental form used in metalworking as it can be cut, drilled and bent into a variety of shapes. Sheets ranged from 0.01mm to 6mm are considered sheet metal. The most common materials of sheet metal are steel and aluminum. Sheet metal is often used for parts with linear shapes or profiles that are discontinuous or not closed. It is common for sheet metal to be CNC laser cut and then bent into the desired shape, see figure 2.7. The minimum bend radius is 2.5 times the material thickness [21].



**Figure 2.7:** Sheet metal laser cut and bent  
*Source: Exero [7]*

### 2.2.5 Injection molding

Injection molding is the process of injecting heated or molten thermoplastic or thermosetting polymer into a mould cavity. If the injected material is a metal the process is called die casting, see chapter 2.2.2. For injection moulding the molten polymer is heated in a barrel, mixed with a helical shaped screw and injected into the mould cavity by a plunger, see figure 2.8. The polymer will cool and harden to the configuration of the cavity [22]. The molds are usually made from steel or aluminum and EDM or CNC-machined to form the features of the desired part. The most common polymer for injection moulding is ABS, see chapter 2.3.2. Note that ABS is a thermoplastic polymer which can be used in injection moulding, not vacuum casting or forming. Other less common materials used as injection material are glasses, elastomers and confections.



**Figure 2.8:** Injection moulding process  
*Source: BCC [16]*

Injection moulding is used extensively in the industry and is the most common method of manufacturing plastic parts. It is ideal for producing high volumes of the same part. Like die casting, injection moulding requires an initial investment. The tooling has a lifetime of 20-30 000 moulds depending on the complexity of the geometry. Injection moulding is a detailed manufacturing process that nearly brings a part to its final form. Post processing includes removing excess material and troubleshooting for moulding faults.

### 2.2.6 Vacuum casting with PUR (Polyurethane) materials

Vacuum casting is a casting process for elastomers and polyurethanes using a vacuum to pull the liquid material into the silicone mold cavity, see chapter 2.3.4. First a master model is made in SLA. A box is built around the model and filled with heated liquid silicone. Once the silicone has cooled and hardened the box is removed and the silicone cube is manually cut in half around the master model, see figure 2.9. This is the process for creating a silicone mold tooling.



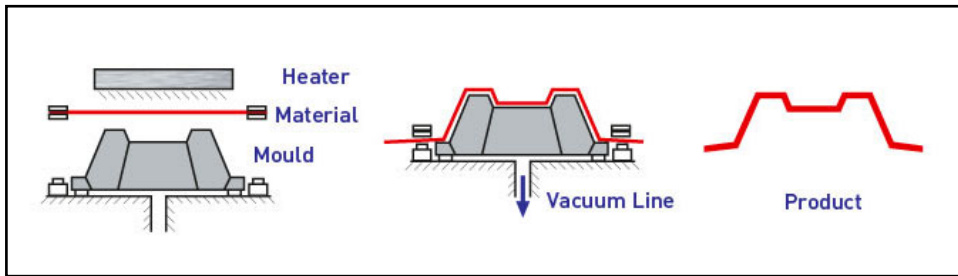
**Figure 2.9:** Silicone mold  
*Source: Renishaw [23]*

For silicone tools, only hard plastics (resin-based plastic, an A & B base) can be used. Hard plastic is mixed under vacuum before it is poured into the silicone forms below 70 degrees. After the mold cavity is filled, the silicone form goes from a vacuum to an oven for curing. Post processing requires cleaving tools, removing material inlet and finishing the mold.

Vacuum casting with PUR is a suitable casting process for low-volume detailed production and prototyping. Depending on the complexity of the geometry silicone molds can last 20-30 casts. The master model is rarely damaged during casting of the silicone molds and can be used repeatably for casting new silicone molds. Vacuum casting requires an initial investment for the master model and a silicone tooling investment for every 20-30 molds. It is considered one the more expensive low-volume plastic production methods.

### 2.2.7 Vacuum forming

Vacuum forming is a relatively new, cheap and simplified version of thermoforming. It is an effective copying technique used for the production of plastic parts in small series. A part is molded through 3D printing or casting and placed into a vacuum forming machine [24]. The forming machine is sealed tight and creates a vacuum. A thin sheet of plastic is heated to a forming temperature and forced against the mold by vacuum, see figure 2.10. After the vacuum is released and the formed plastic part has cooled the part and mold can be detached.



**Figure 2.10:** Vacuum forming process

*Source: Cannon Shelly [25]*

Suitable materials for use in vacuum forming are conventionally thermoplastics. The most common and easiest to use thermoplastic is high impact polystyrene sheeting (HIPS), see chapter 2.3.3. Vacuum forming can mold almost any shape, but requires a notion during design of the mold or die. Draft angles of minimum  $3^\circ$  must be present in the mold to ease the removal of the formed plastic part. Therefore parts cannot have obtuse angles. Relatively deep parts can be formed if the plastic sheet is heated and stretched correctly before contact. A mold will usually last 20-30 processes.

Vacuum forming is very economical and easy method for producing plastic parts at low volume. It is suitable for small prototype series and low product sales that make it not worth investing in injection moulding tooling or other tools.

### 2.2.8 Surface Finish

Aluminum is a versatile and relatively low cost material. It has a high strength to weight ratio, is environmentally friendly and can accept high performance coatings. In its natural state, aluminum has a clean and attractive surface with good corrosion resistance. Treating the aluminum surface alters the surface properties and can improve resistance to corrosion and mechanical wear [26].

Different types of surface treatments have been designed to improve properties of final products such as corrosion resistance, wear resistance, sharp edges, appearance and reflectivity among other things. These treatments can be mechanical, electrochemical, chemical or coatings.

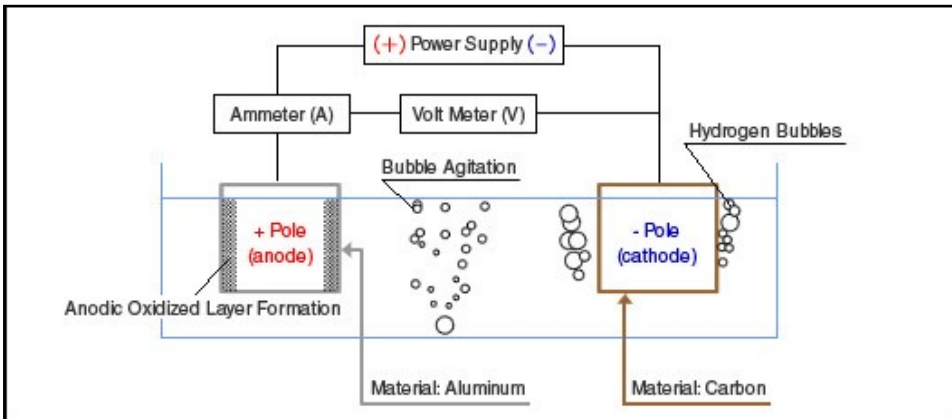
#### 2.2.8.1 Mechanical

Aluminum can be deburred through wire brushing, sanding, polishing, machining, thermal deburring, electrochemical deburring and abrasive blasting [27]. A burr

is an edge or excess material still attached to the material after a modification process, for example extrusion, milling or drilling. Deburring tools removes burrs and smoothens the material improving quality and preparing the aluminum for cosmetic finishes.

### 2.2.8.2 Electrochemical (Anodizing)

Anodizing is an inorganic electrochemical process that artificially increases the naturally occurring oxide layer on the surface of any kind of aluminum alloy. The process involves lowering the part into an electrolytic bath and treating it as the anode in the circuit. The current releases hydrogen at the cathode and oxygen at the surface of the aluminum anode, creating a build-up of aluminum oxide, see figure 2.11. The natural amorphous aluminum oxide surface layer in aluminum alloys tends to be 5 to 15 nm thick when exposed to air at room temperature. Anodizing greatly increases this thickness in aluminum alloys increasing the surfaces corrosion resistance. This is especially good for 6000 series aluminum alloys which have decreased corrosion resistance due to alloy impurities such as silicone, see chapter 2.3.1. However, anodizing does not increase the strength of the aluminum object [28].



**Figure 2.11:** Anodizing process

*Source: Misumi [29]*

With the anodizing process, a wide range of colours are available. The color coating is integral to the aluminum and can not peel, flake or scratch. Anodizing gives aluminum a richer, deeper metallic appearance because anodized coating is translucent. The color will never fade as anodizing is unaffected by sunlight.

### 2.2.8.3 Powder coating

Powder coating is a common organic finish (paint) that offers virtually an unlimited choice of colors. Parts are pre-treated to increase the adhesiveness of the surface before being placed into spray booths. In the spray booths, electro-statically charged powder is sprayed and attracted to the surface of the parts to form an even coating. After coating, the parts are moved to a curing oven that melts the powder to form an even coating that adheres to the surface of the part. Most powder coatings particle size is in the range of 2 to  $50\mu\text{m}$ . Recommended film thickness is  $60\mu\text{m}$ , softening temperature is around  $80\text{ }^\circ\text{C}$  and melting temperature is around  $150\text{ }^\circ\text{C}$ .

Powder coating is very durable, but cannot withstand the same abuse as inorganic finishes. At hot ambient temperatures the coating can start to peel and is easily scraped.

## 2.3 Materials

### 2.3.1 AL 6061-T6

Aluminum 6061-T6 is the most common aluminum alloy used in bicycles and a stock material at manufacturers. The material's largest alloying elements are magnesium and silicon, see Appendix D.1 for data sheet. The alloy is easy to process and weldable. It is resistant to corrosion in both air and sea water. T6 symbolizes the heat treatment performed on the material.

### 2.3.2 Acrylonitrile butadiene styrene (ABS)

ABS is a common thermoplastic polymer known for its impact resistance and toughness. ABS's lightweight and other properties makes it easy to machine, extrude and injection mold. Molding at a high temperatures improves the gloss and heat resistance whereas the impact resistance and strength improves by molding at low temperatures. Since ABS is a thermoplastic polymer it can be used in molding and casting process, but not under vacuum. See Appendix D.2 for data sheet.

### 2.3.3 High Impact Polystyrene (HIPS)

HIPS is a tough, rigid plastic material with high impact strength which can be easily formed and available in a variety of colors. Polystyrene is particularly suit-



able for thermoforming and is commonly used as a support material in vacuum forming processes. It is lighter than ABS, but requires higher temperatures for thermoforming [30].

### 2.3.4 PUR 8051 (Polyurethane)

Polyurethanes are commonly used for manufacturing polymers under vacuum. It is therefore often used for low-volume prototyping and manufacturing. PUR 8051 is a resin that is produced to achieve similar properties to ABS. See Appendix D.3 for PUR 8051 data sheet.

## 2.4 Manufacturers

Authentic manufacturers are determined by their correspondence, quality, price and shipping cost. The research project for this thesis generated multiple areas of interest for production and found Guangzhou, China to be the best suited location, see Appendix E.

China's emerging manufacturing market has developed rapidly alongside its flourishing export trade. It is specifically centered in the south-east of China in the Guangdong province due to its harbor, see figure 2.12. Guangdong contributes approximately 12% of the total national economic output [32]. It is home to two of the fastest growing cities in the world, Shenzhen and Guangzhou. Both cities are heavily focused on innovation. Shenzhen is modernly referred to as the "Silicon Valley of Hardware" and develops more technical and electrical equipment. Guangzhou is referred to as the largest city in China dealing with traditional business. That excludes financial, technical and IT business. In Guangzhou business revolves around "material units" such as *fabric, metals, plastics, construction and agriculture*. Therefore, Guangzhou is naturally home to China's largest aluminum economy.



**Figure 2.12:** Guangdong province

*Source: Wikimedia [31]*

Guangzhou is referred to as the largest city in China dealing with traditional business. That excludes financial, technical and IT business. In Guangzhou business revolves around "material units" such as *fabric, metals, plastics, construction and agriculture*. Therefore, Guangzhou is naturally home to China's largest aluminum economy.

### 2.4.1 SuNPe Manufacturing

SuNPe Manufacturing, established in 2005 is a low volume prototyping and manufacturing company based in Zhongshan, Guangzhou, China. SuNPe delivers services within rapid prototyping, tooling and low volume production. This includes; Rapid CNC Machining, Vacuum Casting, Sheet Metal, Extrusion, Die Casting, Plastic Injection Molding, Finishing and Assembly [33]. SuNPe accept BOM's and return quotations within 3-4 days, see chapter 2.5.

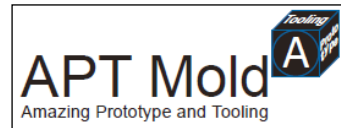


**Figure 2.13:** SuNPe Manufacturing logo

*Source: SuNPe [33]*

### 2.4.2 APT Molding

APT Molding, established in 2008 is a low volume prototyping and manufacturing company based in Zhongshan, Guanzhou, China. APT Molding delivers services within rapid prototyping, tooling and low volume production. This includes; Rapid CNC Machining, Vacuum Casting, Sheet Metal, Stamping, Gluing, Extrusion, Die Casting, Plastic Injection Molding, Finishing, Inspection and Assembly [34]. SuNPe accept BOM's and return quotations within 2 days, see chapter 2.5. APT Molding accept BOM's and return quotations within 1-2 days.



**Figure 2.14:** APT Molding logo

*Source: APT Molding [34]*

## 2.5 Bill of Materials (BOM) and Quotations

A bill of materials (BOM) is a list of parts, components, assemblies and sub-assemblies needed to manufacture an end product. Each part must include material, surface treatment, finish, color, quantity, shipping destination and manufacturing process. Parts are often marked by systematic numbers rather than names and can include remarks if the characteristics are unclear. A BOM is used to communicate between engineers and manufacturing partners. A BOM is often drafted by the purchasing engineer and sent to the manufacturer. In return, the manufacturer will comply with a quotation which includes prices per part and total cost in regards to the BOM. Manufacturers will also leave their own remarks on specific parts or manufacturing processes. They might not have the correct resources or tools for specific processes or recommend alternative processes. BOM's and quotations are constantly changing as they alternate between engineer and manufacturer until both parties are satisfied. Once consensus has been reached a final quotation

is sent from the manufacturer to the engineer based on the latest BOM. Once the quotation is signed by both parties the manufacturing can begin. See Appendix A for a BOM example and Appendix B for quotation examples.

## 2.6 Product Development

This chapter briefly introduces the IPM model and MVP model so the reader has an understanding of how the product was developed. Prototype Beta was designed as an MVP and the IPM model was used to develop Spike.

### 2.6.1 IPM model

The IPM model is a product development model based on Robert G. Cooper's Stage-Gate model. A new phase cannot be started without finishing and fulfilling the milestones of the previous phase. Milestones are set before the phase begins. This type of product development reduces initial resources and makes it easy to measure progress. The IPM model consists of 5 stages, see list below:

1. **Vision** - Find which problem the product is solving, the product's importance and define a project description.
2. **Requirement and technology analysis** - Define the users demand and needs to so derive requirements for the product. Investigate the competitors in the market.
3. **Concept Development** - Define solutions that can be combined into concepts. Derive a minimum viable product or prototype from the best concept.
4. **Test and validation** - Testing technical solutions up against requirements. Derive cost calculations.
5. **Production start-up** - Find manufacturers and distribution channels. Finalize product for market and sale.

### 2.6.2 MVP - Minimum Viable Product

Minimum Viable Product (MVP), is one of the most important lean start-up techniques. An MVP is a product with just enough features to satisfy early customers, and to provide feedback for future product development. Developers can deploy this product to a potential user as an early adopter. Giving a user a functional product with less features gives more power to the user to give feedback on what

## 2. Theory

---

is missing. If a company is in a constant reworking prototyping stage, this strategy lowers the cost, maximizes the information and avoids building products that customers do not want. The final, complete set of features is only designed and developed after considering feedback from the product's initial users.

# 3

## Method

The process described follows the later product development stages of the assistive sports equipment Spike. Up to this point Spike was designed on a conceptual level, but manufacturability had not been taken into consideration. The following chapter presents the author's process from a conceptual design to a manufacturable product for selected parts from Spike. These selected parts are the "Main Frame Profile", "Knee and Calf Supports" and "Seat Post". The seat is excluded from this thesis. Although the product development process is not the focus of this thesis, it is necessary for the understanding of this chapter that parts of the process are included. First, Spike's initial design sketch is presented. Each chapter will begin by introducing a conceptual part from Spike generated by the IPM product development process, see chapter 2.6.1. These parts will be presented with their technical requirements for the product. Technical requirements are not directly relevant for answering the research questions of this thesis, however, they are relevant to fully understand the choices made in designing for manufacturability. The manufacturability of each conceptual part will be assessed. This includes material availability, manufacturing processes and cost. Based on this assessment each part is re-designed for manufacturability and presented with authentic quotations. The theory used in this chapter will be referred to from chapter 2.

Each part's process from conceptual design to manufacturable part has the following content:

1. **Present Part and Requirements**
  - Part description
  - Part parameters
  - Budget
2. **Present Conceptual Design**
  - Design sketches
  - CAD model
3. **Assess Manufacturability**
  - Material availability

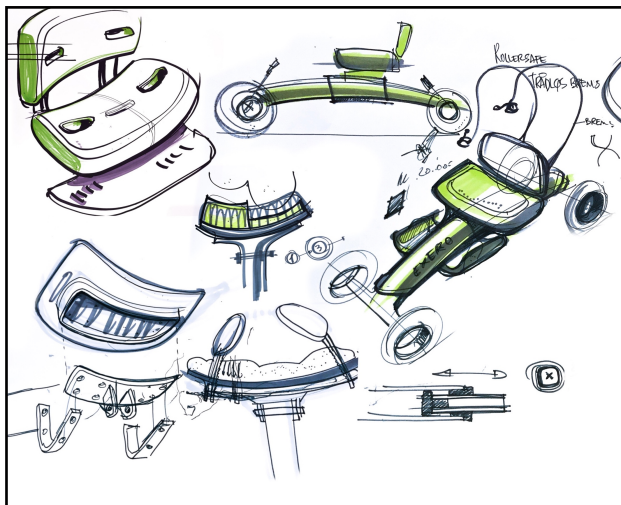
### 3. Method

---

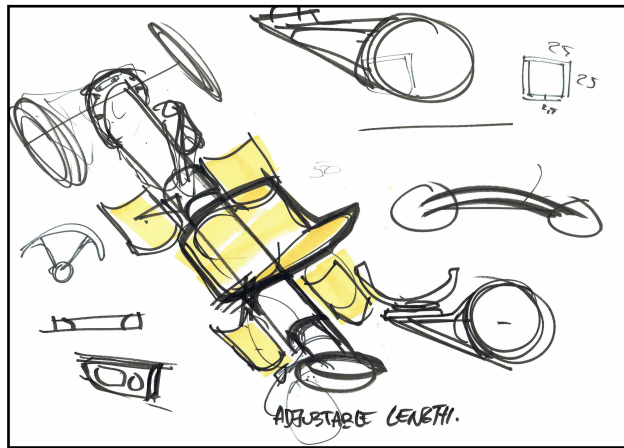
- Manufacturing Processes
  - Manufacturing Cost
4. **Design for Manufacturability**
    - Select manufacturing process
    - Redesign for manufacturability
  5. **Present Manufacturable Part**
    - Manufacturable part
    - Surface finish
    - Material

## 3.1 Sketch Design

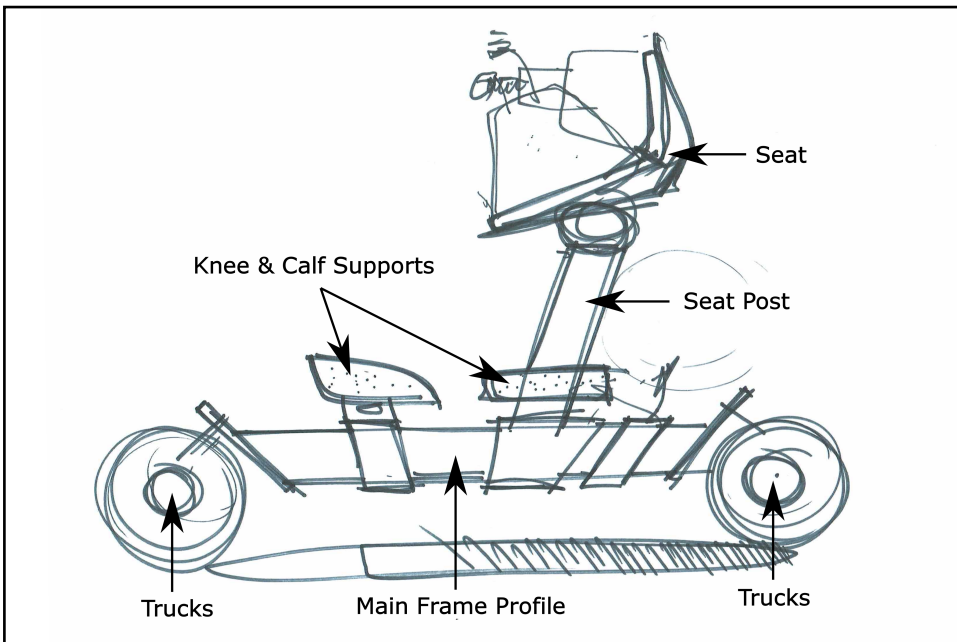
Iterations of sketch design in the concept development stage of the IPM model generated a general design for Spike based on Prototype Beta, see figures 3.1 and 3.2. Spike consists of four parts; "Main Frame Profile", "Knee and Calf Supports", "Seat Post" and "Seat", see figure 3.3.



**Figure 3.1:** Spike sketch design; Isometric view  
*Source: Exero [7]*



**Figure 3.2:** Spike sketch design; Isometric view 2  
*Source: Exero [7]*



**Figure 3.3:** Spike sketch design; Parts  
*Source: Exero [7]*

## 3.2 Main Frame Profile

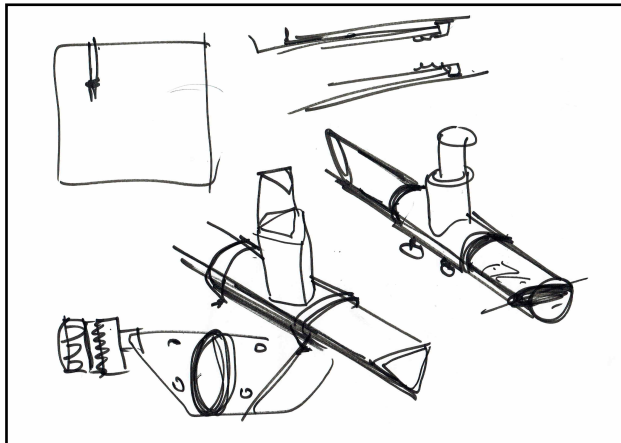
The main frame profile is the root of the Spike. It connects the seat, knee and calf supports to the steering system. During the conceptual phase in the IPM model it was important that the profile be a single tube of arbitrary shape, see figure 3.3. The profile must be robust enough to hold the weight of the supports and user and must have an adjustability mechanism for the supports to move along the profile. The ends of the profile must connect with the trucks. See table 3.1 for dimensional requirements. The company budget for this part was \$750/unit when purchasing 15 units.

**Table 3.1:** Main Frame Profile Requirements

Main Frame Profile Requirements			
Length	Tube diameter	Tube thickness	Support distance
Min: 800mm	Min: 35mm	Min: 2.5mm	Min: 340mm
Max: 780mm	Max: 70mm	Max: 3.5mm	Max: 540mm

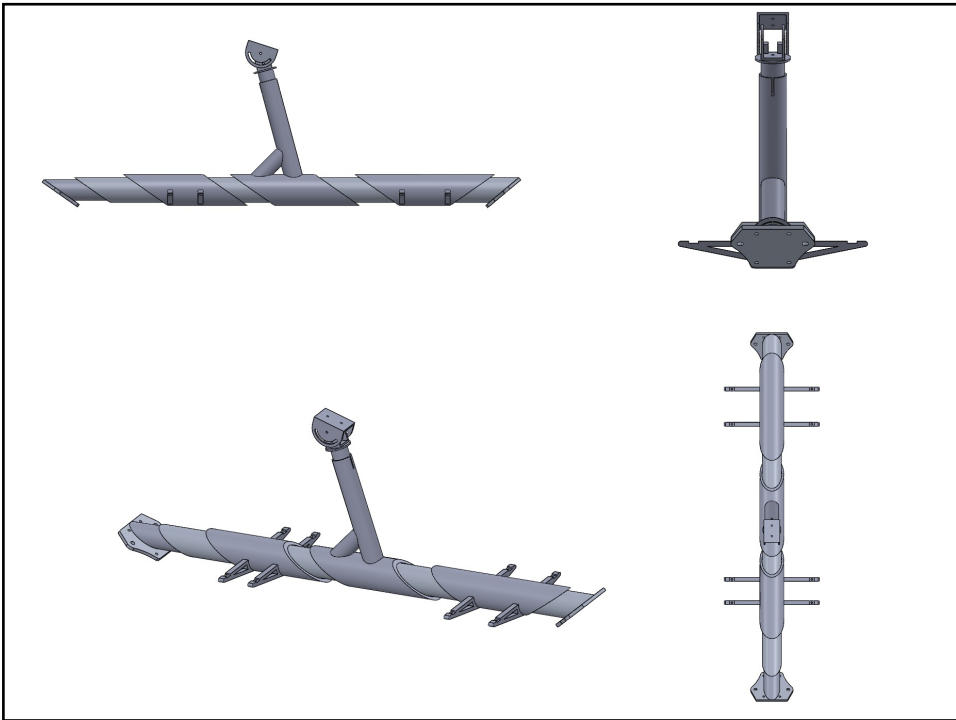
### 3.2.1 Conceptual design

A conceptual design for the main frame profile was 3D modelled based on a "tube in tube" mechanism with standard tubing, see figure 3.4.



**Figure 3.4:** "Tube in tube" mechanism  
*Source: Exero [7]*





**Figure 3.5:** Conceptual Design; Main frame profile  
*Source: Exero [7]*

A long main tube connects the trucks at each end with base plates. Three shorter tubes, referred to as "sliders" slide along the main tube. The front and rear sliders have four arms that connect to the knee and calf support. The middle slider connects to the seat post. All three sliders can be adjusted and moved along the main tube through bolts and bored holes, see figure 3.5. These bolts also serve as radial support for the sliders on the main tube.

### 3.2.2 Manufacturability

The conceptual design for the main frame profile was based on the assumption that Al 6061-T6 circular tubing was available in all dimensions. Using standard tubing profiles for this part served an economical purpose in accordance with chapter 2.1.3 as standard tubing does not require obtaining extrusion tooling and are stock items.

Standard tubing catalogs were gathered from manufacturers, see table 3.2. Combinations of standard tubes were put together in table 3.3 based on the main frame profile dimensional requirements.

### 3. Method

---

**Table 3.2:** Aluminum Tubing Standard Dimensions

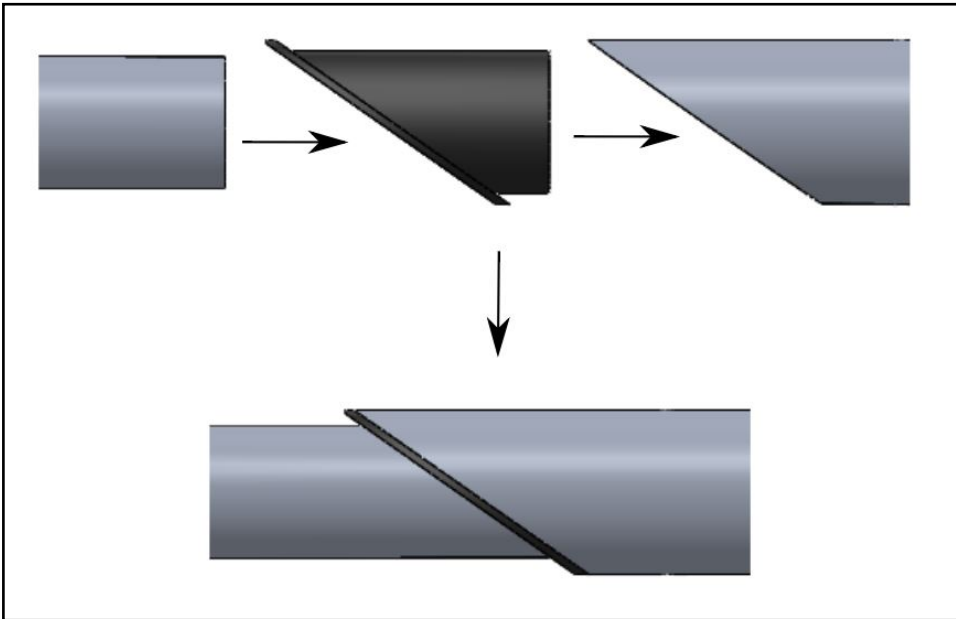
Aluminum Tubing								
Manufacturer	70x10	60x5.0	55x3.0	48x3.5	48x3.0	48x2.5	40x3.5	38x3.5
Astrup	X	X				X	X	X
EA Smith		X					X	X
Tibnor		X					X	X
Ula Jern		X	X	X				
Eastmaster		X					X	
SuNPe					X			
ATP Mold					X			

\*X marks available tube

**Table 3.3:** "Tube in Tube" Combinations

Combinations		
Slider	Main tube	Gap
60x5.0	48x3.5	2mm
70x10	48x3.5	2mm
60x5.0	48x3.5	2mm
70x10	48x3.5	2mm
60x5.0	48x3.0	2mm
70x10	48x3.0	2mm
60x5.0	48x3.0	2mm
70x10	48x3.0	2mm
60x5.0	48x2.5	2mm

Further research showed that for a "tube in tube" adjustment mechanism to work without looseness, the gap between tubes cannot be larger than 0,25mm. Table 3.3 shows that all combinations of compliant tubes have 2mm gaps. The gap could be compensated by sleeves, see figure 3.6, but simulations and prototype testing proved they were not firm enough to remove looseness between the tubes.



**Figure 3.6:** "Tube in tube" sleeve  
*Source: Exero [7]*

The "tube in tube" conceptual design for the main frame profile would not be possible with standard tubing due to the gap between the tubes. To make tubes slide along each other with gaps smaller than 0,25mm would require extruding or die casting. If these methods are necessary for the circular "tube in tube" conceptual design then a new tube profile could be designed based on these manufacturing processes. Furthermore the base plates for connecting the trucks would need to be welded at the ends of the main tube.

Extrusion is a process used to create objects of a fixed cross-sectional profile, see chapter 2.2.1. A material is pushed through a die of the desired cross-section and produces long, thin tubes and tracks with custom profiles. The tubes can be bent during extrusion by adding a bending tooling at the end.

Die casting is a metal casting process that forces molten metal under high pressure into a mold cavity, see chapter 2.2.2. After the molten metal is injected into the mold cavity it rapidly cools and solidifies into a final part, called the casting. Castings can be designed in various shapes and bends, but are limited by the length of the tube.

BOM's were sent to manufacturers including extrusion and die casting costs for custom aluminum tubes less than 1m. Table 3.4 and 3.5 show a list of the average die casting and extrusion quotation prices gathered from manufacturers in

Guangdong, China.

**Table 3.4:** Die Casting Tooling Prices

Die Casting Tooling	
Shape	Price
Circular/Square	6000 NOK
Elliptical	8000 NOK
Custom	10 000 NOK
Detailed	14 000 NOK
Set-up cost	1000 NOK
Price/per 15 units	2000 NOK
Lead time	20 days

**Table 3.5:** Extrusion Tooling Prices

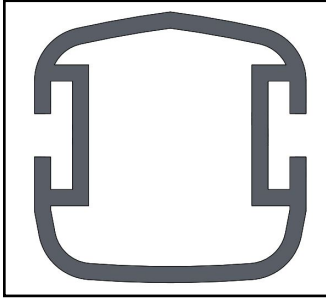
Extrusion Tooling	
Shape	Price
Circular/Square	4000 NOK
Elliptical	6000 NOK
Custom	8000 NOK
Detailed	12 000 NOK
Bending tooling	4000 NOK
Set-up cost	800 NOK
Price/per 15 units	500 NOK
Lead time	18 days

### 3.2.3 Design for manufacturability

Tables 3.4 and 3.5 shows the price fluctuations between die casting and extrusion tooling. Extrusion tooling was cheaper and faster to set up than die casting tooling. The tooling investment pay-off would come quicker with extrusion tooling due to the low unit price per extrude. Extrusion tooling can only extrude straight tubes without extra tooling, whereas die casting tooling cavities can be non linear. Once a die cast tooling is made, the shape of the part cannot be change during molding. During extrusion, an extruded tube can be bent by assembling a bending tooling at the end. This comes as an extra expense for extrusion, but allows the choice of bending the tube or not.

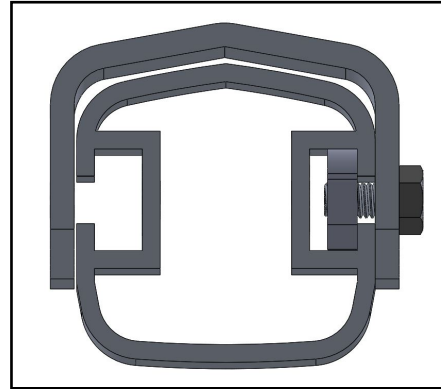
Based on the quotations from manufacturers the manufacturing process chosen for the redesign of the main frame profile was extrusion; cold. Although hot extrusion is the more common method, cold extrusion gives better tolerances and a smoother surface finish, see chapter 2.2.1.

The conceptual design implemented radial support and adjustments for supports in a cumbersome way. Knowing that the main frame profile would be a custom extrude rather than a standard stock tube gave the designers the opportunity to design a custom cross section that compliments the requirements of the part, see figure 3.7. The unorthodox rounded square shape of the cross section allowed the sliders to be laser cut and bent sheet metal. Sheet metal and laser cutting is one of the simplest and cheapest manufacturing processes, see chapter 2.2.4. The cross section was designed with "T-tracks" for the sliders adjustability. This way the sliders couldn't rotate around the main tube and could be tightened by t-locks rather than bolts, see figure 3.8 and 3.9.



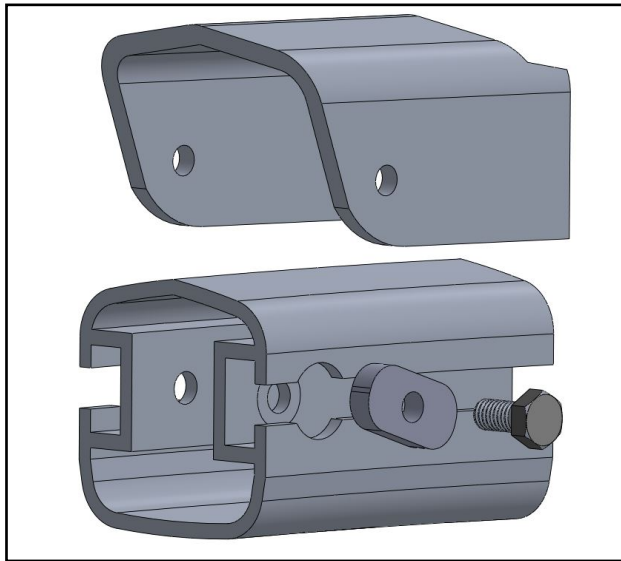
**Figure 3.7:** Main frame profile cross section

*Source: Exero [7]*



**Figure 3.8:** Slider and T-lock

*Source: Exero [7]*

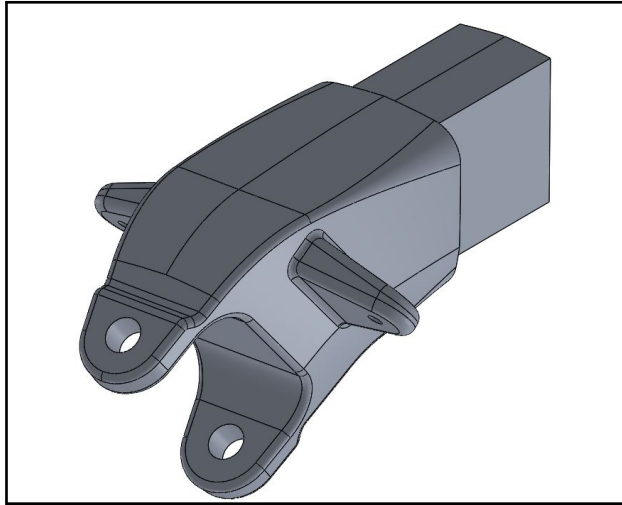


**Figure 3.9:** Slider and T-lock exploded view

*Source: Exero [7]*

Having a custom cross section for the main frame profile allowed the engineers to design "profile end caps" rather than base plates to attach the trucks, see figure 3.10. The profile ends are attached to the main frame profile at each end by bolts allowing for separation. Having the opportunity to disassemble the trucks from the main frame profile made it a modular design, see chapter 2.1. Removing the trucks would also allow the sliders to be detached for maintenance or replacement. Quotations from manufacturers showed that the profile could be CNC-milled from a block of ABS material. CNC-milling can obtain the small tolerances needed for

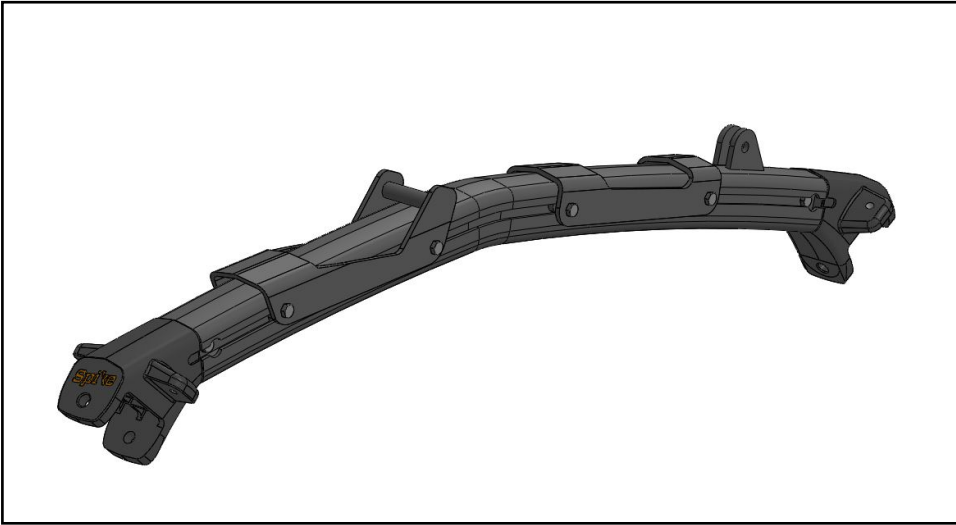
a tight fit between the profile ends and the main frame profile, see chapter 2.2.3 for CNC-milling and Appendix B.2 for profile end manufacturing quotation.



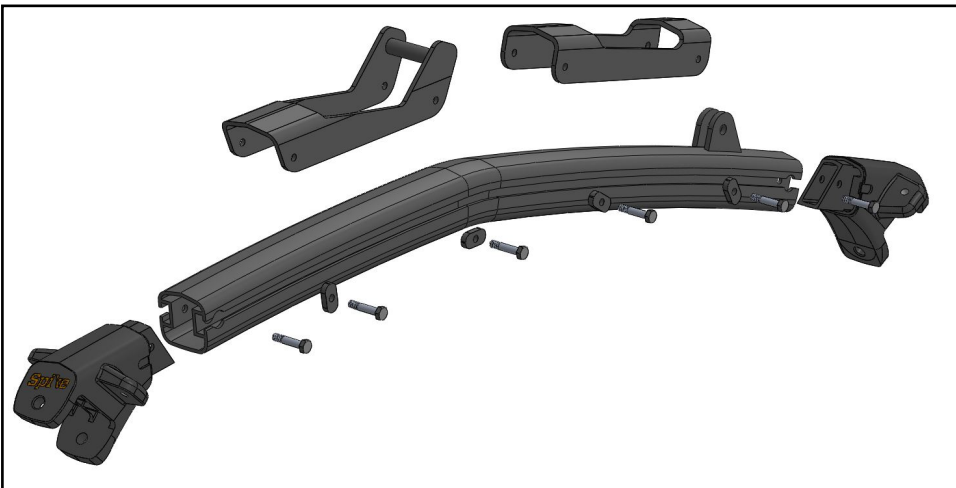
**Figure 3.10:** Profile end  
*Source: Exero [7]*

#### 3.2.4 Manufacturable part

The main frame profile's redesign for manufacturability required alternating BOM's and quotations between designer and manufacturers. The main frame profile's manufacturable design is an extruded and bent custom tube with T-tracks and profile end caps, see figure 3.11 and 3.12. The fit between the profile ends are "Transition Tight Fit (H7/j6)" to avoid any movement between the parts. This is obtainable for the main frame profile due to cold extrusion and post processing. The sliders are laser cut and bent sheet metal that form around the cross section. The sliders can be adjusted along the main frame profile through T-locks. The main frame profile has two brackets welded at the rear end for connecting the seat post, see chapter 3.4.



**Figure 3.11:** Manufacturable Part; Main frame profile, profile ends and sliders  
*Source: Exero [7]*



**Figure 3.12:** Manufacturable Part; Exploded view  
*Source: Exero [7]*

The main frame profile will be powder coated matte black Al 6061-T6. Powder coating adds an additional layer to the metal and will therefore hide the welds around the brackets, see chapter 2.2.8.3. See Appendix C.1 for production drawing.

The profile ends will be anodized matte black Al 6061-T6. Anodizing is an electrochemical process that replaces the oxide layer on the surface of the metal. In this

way the the finish becomes a part of the material and it is unscrapable, see chapter 2.2.8.2. Anodizing is a good finishing process for smooth CNC parts such as the profile end. See Appendix C.2 for production drawing and BOM.

The sliders design could not be completed until attachments for calf and knee supports were implemented, see chapter 3.3.

## 3.3 Knee and Calf Supports

The knee and calf supports are what stabilizes the user's body in the seating. Most of the user's weight is put on the knee supports, especially during propulsion. Therefore, the supports needed proper form. During the conceptual phase in the IPM model it was important that the knee and calf supports were lightweight, robust and that their individual designs complimented one another.

The supports were connected to the sliders which could be adjusted along the main frame profile. Due to the fact that many users have unsymmetrical limbs, the supports must be individually adjusted on the slider. Both supports require strapping attachments. See table 3.6 for dimensional requirements. The company budget for one pair of knee supports was \$200 and \$170 for one pair of calf supports when purchasing 15 units.

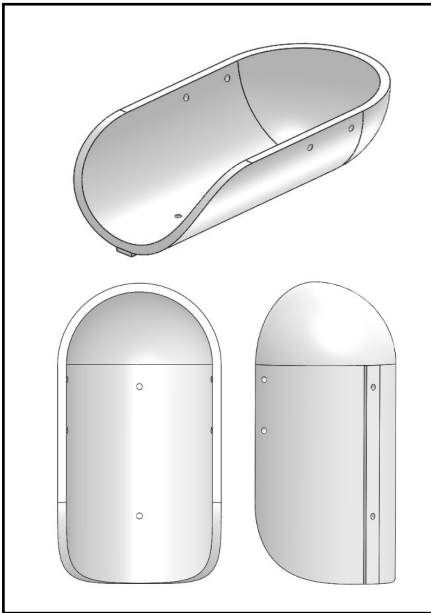
**Table 3.6:** Knee and Calf Support Requirements

<b>Knee and Calf Support Requirements</b>			
<b>Part</b>	<b>Length</b>	<b>Inner diameter</b>	<b>Individual Adjustability</b>
Knee Support	225mm	150mm	80mm
Calf Support	250mm	100mm	80mm

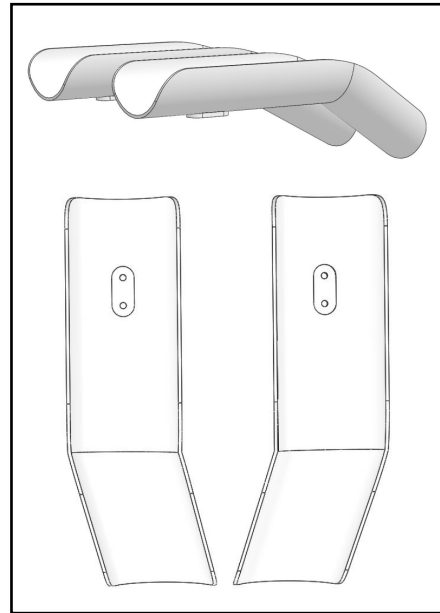
### 3.3.1 Conceptual design

A conceptual design for the knee and calf supports was 3D modelled based on the adjustability requirements, see figure 3.13 and 3.14.



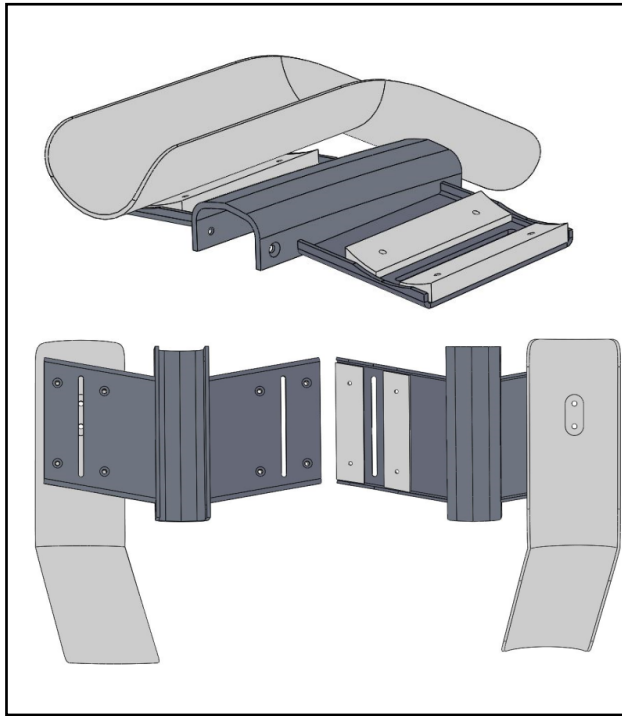


**Figure 3.13:** Conceptual Design;  
Knee support  
*Source: Exero [7]*



**Figure 3.14:** Conceptual Design;  
Calf support  
*Source: Exero [7]*

The right and left calf supports designs were symmetrical across each other whereas the knee supports were identical. The circular form of the supports were stabilized by two support brackets. The brackets were screwed to a base plate that was welded on each side of the slider, see figure 3.15. The supports had raised tracks with bored holes that allowed for individual adjustments on the slider.



**Figure 3.15:** Partial assembly of calf support, support brackets, base plate and slider

*Source: Exero [7]*

### 3.3.2 Manufacturability

The supports and their attachment to the sliders were designed without consideration for manufacturability other than that supports would be manufactured in a polymer material and the base plate made of sheet metal.

Polymers can be manufactured in multiple ways. The polymer manufacturing methods reviewed for the supports were injection molding, vacuum forming, vacuum casting and CNC machining. Injection molding is the process of injecting heated or molten thermoplastic or thermosetting polymer into a mould cavity. This requires investing in a tooling that lasts 20-30 000 molds depending on the complexity of the design, see chapter 2.2.5. ABS is a common material for injection molding, see chapter 2.3.2.

Vacuum forming is a very economical and easy method for producing plastic parts at low volume. A master mold is 3D printed or CNC machined and placed into a

vacuum forming machine. A thin sheet of polymer is forced against the mold by vacuum. A master mold can cycle this process 20-30 times. Once the polymer has cooled around the mold it must be detached. This introduces certain requirements for the mold design. Draft angles of minimum  $3^\circ$  must be present in the mold to ease the removal of the formed plastic part. Therefore parts cannot have obtuse angles, see chapter 2.2.7. HIPS is a common material for vacuum forming, see chapter 2.3.3.

Vacuum casting is a casting process that creates a vacuum to pull the liquid material into a silicone mold cavity. The mold cavity is created by hardening silicone around a master mold. The master mold can last over 10 000 cycles, but the silicone molds last only 20-30 cycles. Vacuum casting with polyurethanes is a suitable casting process for low-volume detailed production and prototyping. For low volume polymer production it is considered a more expensive manufacturing process than vacuum forming, but produces more robust and detailed parts, see chapter 2.2.6. Polyurethanes (PUR) are common materials for vacuum casting, see chapter 2.3.4.

CNC milling polymers requires a block of material bigger than the part to be made. This generates a lot of excess material which makes CNC machining large parts expensive. Depending on the complexity of the design, it could require a 5-axis milling machine, see chapter 2.2.3.

BOM's were sent to manufacturers to get an understanding of the designs manufacturability and cost, see Appendix A.1. Considering the manufacturing volume of 15 units, vacuum casting, forming and CNC machining were all viable processes. Injection molding was not included in quotations by manufacturers as they deemed it cost ineffective for this project. Investing in a mold tooling would take 500+ units to pay off before an economical return. The base plates could be manufactured through laser cutting and bending sheet metal. Table 3.7 shows an overview of manufacturing cost for the supports conceptual design. The costs are set for 20 units, as this is the output for vacuum forming and casting. See Appendix B.4 and B.5 for authentic quotations.

**Table 3.7:** Supports Manufacturing Process Costs

Manufacturing Prices					
Part	Manufacturing Process	Material	Color	Quantity	Price/unit
Knee Support	CNC	ABS	Matte white	20	\$205
	Vacuum forming	HIPS	Matte white	20	\$92*
	Vacuum casting	PUR 8051	Matte white	20	\$105
Calf Support Left	CNC	ABS	Matte white	20	\$185
	Vacuum forming	HIPS	Matte white	20	\$80*
	Vacuum casting	PUR 8051	Matte white	20	\$93
Calf Support Right	CNC	ABS	Matte white	20	\$185
	Vacuum forming	HIPS	Matte white	20	\$80*
	Vacuum casting	PUR 8051	Matte white	20	\$93
Support Bracket	CNC	ABS	Matte white	80	\$92
	Extrusion	ABS	Matte white	80	\$174
Base Plate	Sheet metal	AL 6061-T6	Matte black	20	\$15

\*Design requires modification

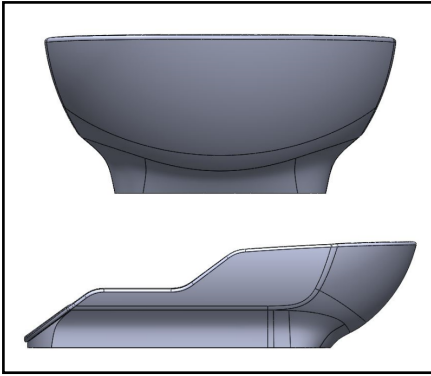
Reviewing the quotations showed that CNC machining was an expensive process for parts as big as the supports. Vacuum casting and forming were cheaper processes, the latter being the cheapest at \$92 and \$80 per knee and calf support respectively. All quotations received from manufacturers noted that the knee and calf supports could not be vacuum formed in their current design. Vacuum forming has stricter requirements than casting since the polymer is being formed around master model, not molded. Neither the calf or knee support had the correct slip angles or geometry for vacuum forming. Both supports could be vacuum cast and the support brackets could be CNC machined or extruded, see chapter 2.2.1.1 for plastic extrusion. The base plates could be manufactured through forming sheet metal.

### 3.3.3 Design for manufacturability

Based on the assessment for manufacturability, the manufacturing process chosen for the supports was vacuum casting with PUR materials. CNC machining proved to be an expensive manufacturing process for the supports. A whole block of ABS had to be machined down to match the part, costing a lot in excess material. Vacuum forming is an effective copying process for polymer parts, but restricts the design geometrically. All though vacuum casting was slightly more expensive, the geometric restrictions are absent allowing the engineers to incorporate more features, thickness and intricate angles into the design. Each support in the conceptual design required two supports brackets on each side for stability. These brackets can be implemented into the supports design if manufactured through vacuum casting.

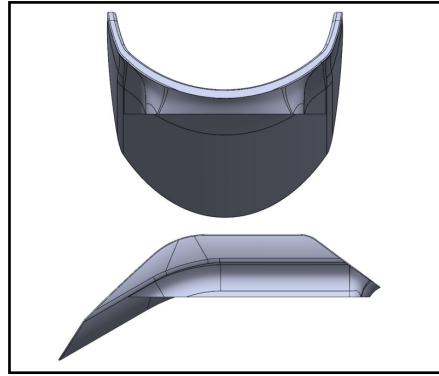
The supports sideways stability needed to be robust as this is where the user presses their weight during steering. For the redesign of the supports the stability would not come from the slider and support brackets, but from the supports themselves. Since the supports will be vacuum cast they could be given a robust base underneath, see figure 3.16 and 3.17. The adjustment slot originally on the base plate could

therefor be moved to the supports.



**Figure 3.16:** Knee support base design

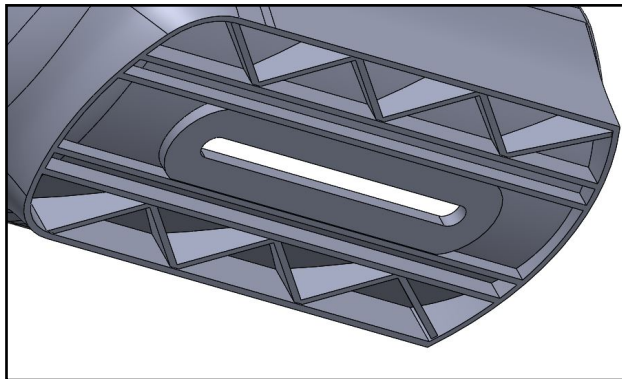
*Source: Exero [7]*



**Figure 3.17:** Calf support base design

*Source: Exero [7]*

The calf supports were designed identical, as the knee supports. It will require only one master model and silicone mold during vacuum casting. This made the calf supports design modular and more cost effective, see chapter 2.1.2. Furthermore, vacuum casting could allow an intricate slot design under the base of the supports, see figure 3.18. These slots will serve as adjustment slots for the screws, but also as guiding slots on the sliders to keep the supports from rotating and adding radial support. This gave the supports base a multi-functional design, see chapter 2.1.4.

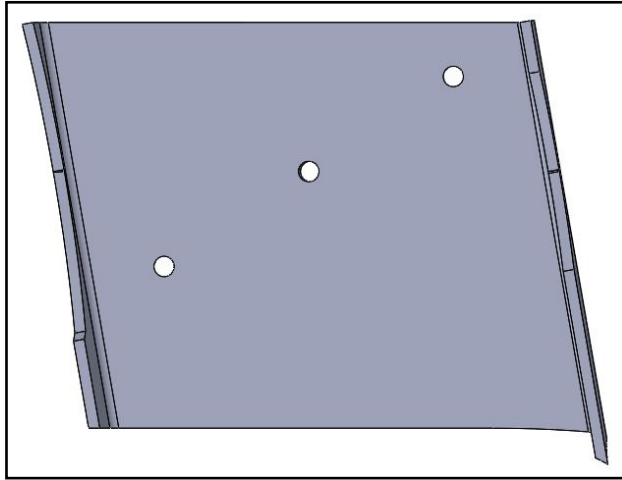


**Figure 3.18:** Base slots

*Source: Exero [7]*

As mentioned the adjustment slot was moved from the base plate to the support. This requires a single bored hole on the base plate for an adjustment nut and two bored holes for the guiding slots, see figure 3.19. The adjustment slot on the base

plates were creating critical material deformations at the edges. Replacing the base plate's adjustment slot with a hole greatly strengthened the material.

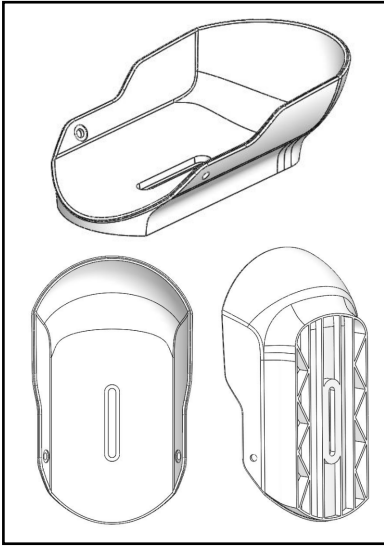


**Figure 3.19:** Base plate

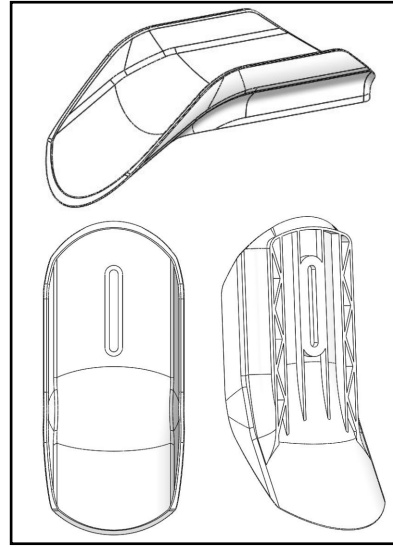
*Source: Exero [7]*

#### 3.3.4 Manufacturable part

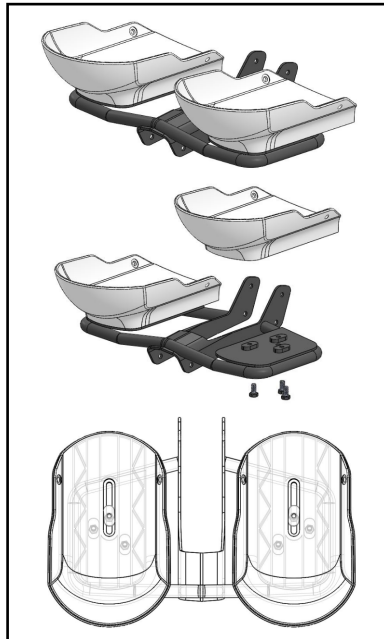
The knee and calf supports manufacturable design are vacuum-casted molds of PUR material, see figure 3.20 and 3.21. They have bored holes on the sides for the attachment of strapping and slots underneath for adjustment and guiding, see figure 3.22. The supports are fastened, guided and adjusted to the base plate by threaded T-locks and bolts. The base plates are welded onto bent standard tubing that is welded to the slider from chapter 3.2.4.



**Figure 3.20:** Manufacturable Part; Knee support  
*Source: Exero [7]*



**Figure 3.21:** Manufacturable Part; Calf support  
*Source: Exero [7]*



**Figure 3.22:** Knee support and slider assembly  
*Source: Exero [7]*

A master model of both the knee and calf support will be 3D printed or CNC machined by the manufacturer. Silicone cavity molds will be hardened around the master model which will last for 20-30 castings. The supports will be cast in matte white PUR material and given a smooth finish. The base plates and bent tubing will be manufactured with the sliders as a whole part and powder coated matte black to cover the welds.

## 3.4 Seat Post

The seat post is the connector between the seat and the main frame profile. During the conceptual design phase in the IPM model it was important that the seat post be robust enough to withstand the moment forces generated by the user during steering. The seat post must have vertical and radial adjustments to control seat height and angle. See table 3.8 for dimensional requirements. The company budget for the seat post was \$200/unit when purchasing 15 units.

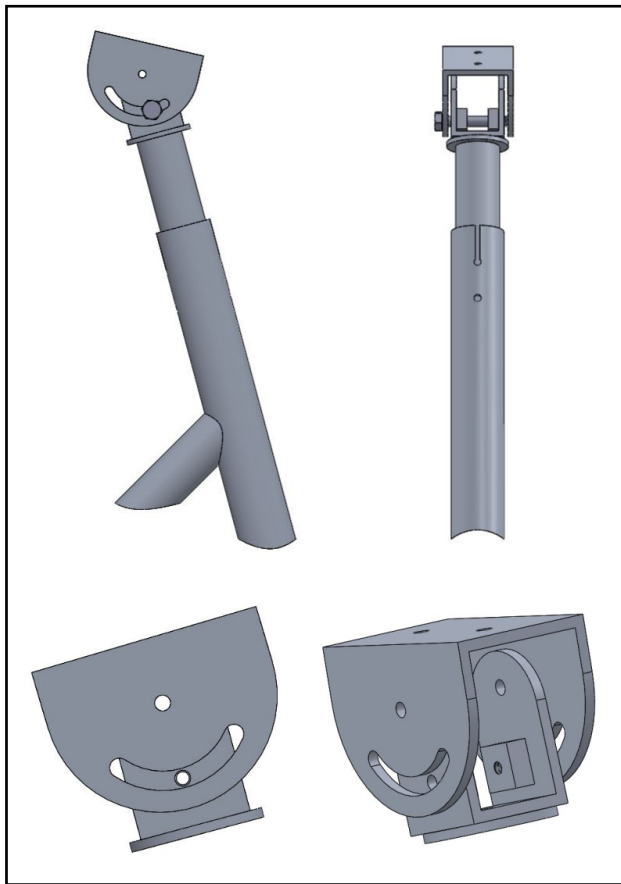
**Table 3.8:** Seat Post Requirements

Seat Post Requirements	
Height	Angular adjustment
Min: 140mm	From: 45°
Max: 420mm	To: 75°

### 3.4.1 Conceptual design

A conceptual design for the seat post was 3D modelled based on a "tube in tube" mechanism with standard tubing and adjustability requirements, see figure 3.23. See figure 3.5 in chapter 3.2 for assembly with the main frame profile's conceptual design.





**Figure 3.23:** Conceptual Design; Seat post  
*Source: Exero [7]*

A large tube was welded to the slider with a 45 °support. A small adjustment tube could be vertically adjusted inside the large tube. An angular adjuster part was welded to the top of the adjustment tube. The seat could be screwed on the angular adjuster's face, requiring a flat surface. The angular adjustment part had a parabolic slot that allowed the seat to be angled by tightening and loosening a screw, see figure 3.23.

### 3.4.2 Manufacturability

The conceptual design of the seat post was designed without consideration for manufacturability other than the assumption that Al 6061-T6 circular tubing was available in all dimensions. Using standard tubing profiles for this part served an

economical purpose in accordance with chapter 2.1.3 since standard tubing does not require obtaining extrusion tooling and are stock items. For the amount of forces the seat post would undertake during steering, the diameter of the tube would need to be bigger than 45mm. As discovered in chapter 3.2.2 the necessary tube dimensions were not stock items at manufacturers. Also a 2mm gap filled by a sleeve between the tubes would not be strong enough. Hence, the tubing for the seat post needed to be extruded adding an additional extrusion tooling investment.

Different manufacturing processes were considered for the angular adjuster part. A BOM was sent to different manufacturers including sheet metal manufacturing, see chapter 2.2.4 and CNC machining, see chapter 2.2.3. All manufacturers could manufacture the angular adjuster through sheet metal, laser cutting and bending, but none could guarantee a flat surface on the top face for the seat placement. Sheet metal bending cannot produce perpendicular edges and are limited to a minimum bend radius of 2.5 times the material thickness. CNC machining the angular adjuster was possible but proved to be an expensive manufacturing process. It would require a part size block of material for both the top and bottom part of the angular adjuster. Since the parts were so thin it would generate a lot of excess material.

Based on manufacturing theory and quotations from manufacturers the seat post was poorly designed for manufacturing. Therefore the conceptual design needed to be completely redesigned for manufacturability.

#### **3.4.3 Design for manufacturability**

Based on the dimensional requirements and comments from manufacturers the seat post was redesigned for sheet metal and standard tubing manufacturing. The seat post required height and angular adjustments. During manufacturable redesign certain notions were stated;

- The movement of the seat post will always be moved in accordance with the knee and calf sliders.
- The distance from the seating to the knee supports will always be the length of the users thighs.
- The angle of the seat is linked to the knee supports, but can be adjusted explicitly.

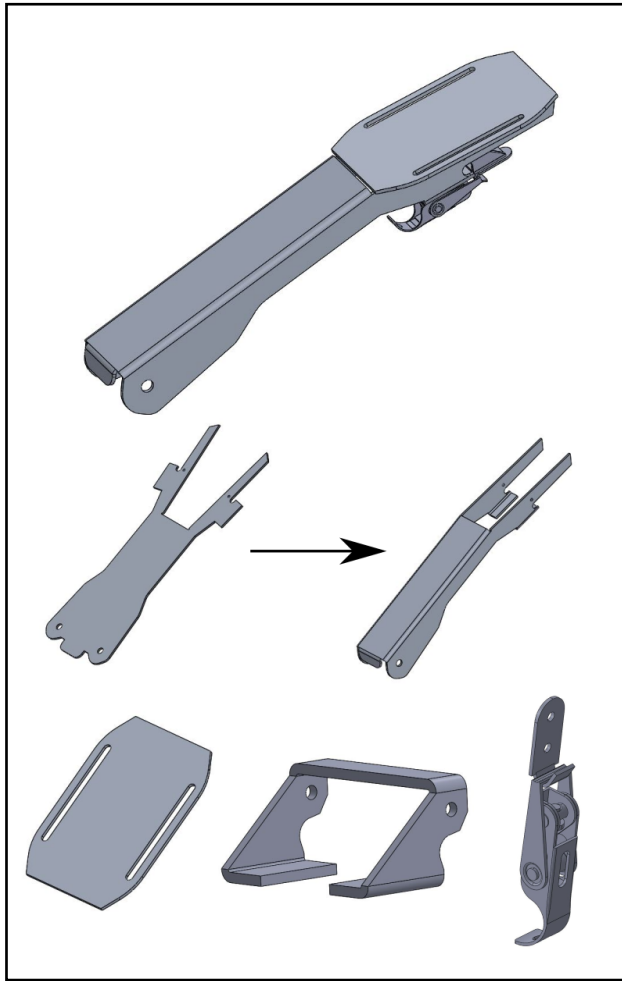
Considering the selected manufacturing processes and design notions the seat post was divided into two parts, "Seat Arm" and "Seat Post". The seat arm connects the seat to the knee support slider and adjusts for thigh length. The seat post connects the seat to the main frame profile and adjusts for seat angle and height, see figure 3.24.



**Figure 3.24:** Seat arm and post design

*Source: Exero [7]*

The seat arm was solely designed through sheet metal manufacturing and welding. Sheet metal allows the design to be cheap and easy to form around other parts. The bottom part of the seat arm was laser cut and bent to fit around the knee support slider, see figure 3.25 for flattened and bent sheet metal part. A sheet metal plate was welded on top with laser cut slots for seat adjustment. A lock holder and locking brackets were welded to the bottom to connect the seat post.



**Figure 3.25:** Seat arm design

*Source: Exero [7]*

Since the seat post was divided into two parts the seat arm functions as a structural member bearing part of the user load. Therefore, the seat post could be designed as the "tube in tube" conceptual design, but with smaller tubes. Standard bicycle seat post tubes are commonly 28.3mm and 32.5mm in dimension but have gaps less than 0.1mm. Aluminum tube manufacturers have these tube dimensions as stock items as they are standard for bicycle posts. This was a cheap and secure manufacturing process. Standard components reliability factor are well ascertained, see chapter 2.1.3. The seat post was therefore designed with standard bicycles tubes.

A bracket was welded at the bottom of the seat post to connect the main frame profile. The smaller adjustment tube has a perpendicular rod welded at the top

connecting to the seat arm, see figure 3.26.



**Figure 3.26:** Seat post design

*Source: Exero [7]*

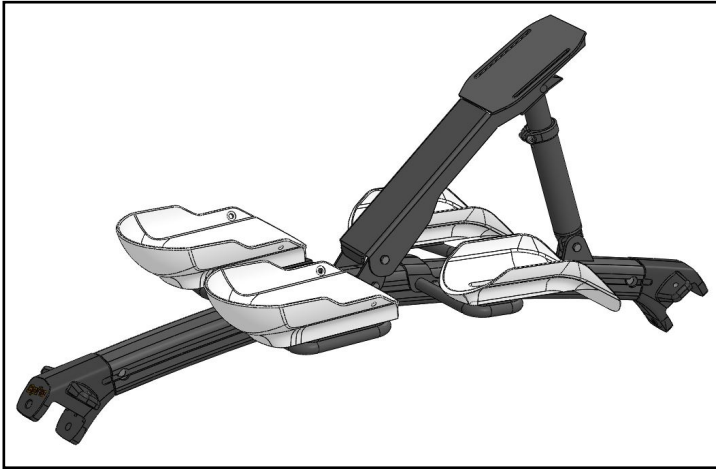
### 3.4.4 Manufacturable part

The seat arm consists of laser cut, bent and welded sheet metal and locking brackets. The top face of the seat arm has bored slots for adjusting the seat towards the knee supports depending on user thigh length. The seat post is manufactured from standard bicycle tubes. It is connected at the main frame profile by a bolt and locked to the seat arm with locking brackets. The adjuster tube in the seat post

### 3. Method

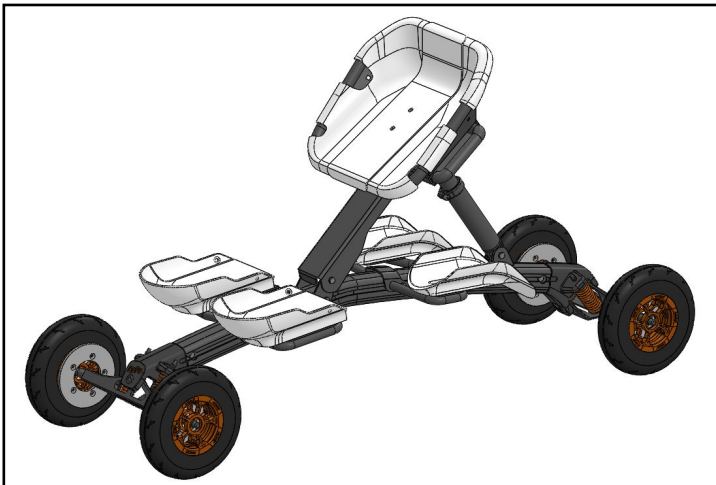
---

is locked by a standard bicycle clamp. Releasing the clamp allows the seat post to adjust for seat height and angle, see figure 3.27 for full assembly. Both parts will be powder coated matte black Al 6061-T6, see chapter 2.2.8.3.



**Figure 3.27:** Manufacturable Design; Seat post and arm  
*Source: Exero [7]*

The conceptual redesign of the seat and trucks are not included in this thesis since they needed no redesign for manufacturability. The seat and trucks are included in figure 3.28 to show the full assembly of the manufacturable product, Spike.



**Figure 3.28:** Manufacturable Design; Spike  
*Source: Exero [7]*

# 4

## Results

This chapter presents the results obtained from chapter 3. Each manufacturable part will be presented with an authentic quotation from an exclusive manufacturer. The quotations includes manufacturer, manufacturing process, manufacturing cost, shipping cost and lead time. All shipping is by plane to Trondheim, Norway and estimated at 2-5 days. Quotations were received from multiple manufacturers. The process of elimination is not included in this chapter, but was based on the manufacturer's quality, cost and correspondence.

### 4.1 Main Frame Profile

The main frame profile will be manufactured at APT Molding in Zhongshan, Guangzhou, China, see 4.1 for quotation. The design of the profile requires investing in \$1400 extrusion tooling and \$800 bending tooling. After extrusion and bending the profile is deburred to remove excess material and prepare for welding of the seat post brackets. The ends of the profile are polished and sanded to achieve a "Transition Tight Fit (H7/j6)" tolerances for the profile ends. The surface is powder coated with a matte black finish.

The total price and time for tooling, manufacturing and shipping is 35 days and \$2375 for 1 unit, 37 days and \$600/unit for 5 units and 39 days and **\$227.3/unit** for 15 units. See Appendix B.1 for authentic quotation.

## 4. Results

**Table 4.1:** Main Frame Profile; ATP Molding Quotation

Main Frame Profile Quotation				
Manufacturer	Manufacturing Process	Material	Surface Finish	Color
ATP Molding	Extrusion, Bending, Welding	Al 6061-T6	Powder Coated	Matte Black
Quantity	Lead Time	Unit Price	Total Price	Shipping
1	8 days	\$75	\$75	\$100
5	10 days	\$62	\$310	\$490
15	12 days	\$32	\$480	\$730
Tooling Quotation				
Manufacturer	Description	Quantity	Lead Time	Tool Price
ATP Molding	Extrusion Tooling	1	22 days	\$1400
ATP Molding	Bending Tooling	1	22 days	\$800

### 4.1.1 Profile End

The profile ends will be manufactured at APT Molding in Zhongshan, Guangzhou, China, see table 4.2 for quotation. The part is manufactured by a 5-axis CNC milling machine. The ends are polished and sanded to achieve a "Transition Tight Fit (H7/j6)" for the main frame profile. The surface of the part is finished in anodized matte black and the "Spike" engraving is finished in anodized orange.

The total price and time for manufacturing and shipping is 17 days and \$310/unit for 2 units, 19 days and \$223/unit for 10 units and 25 days and **\$191.2/unit** for 30 units. \$191.2/unit for profile ends and \$227.3/unit for the main frame profile when purchasing 15 units is a total of **\$609.7** which is below the company budget of \$750. See Appendix B.2 for authentic quotation.

**Table 4.2:** Profile End; ATP Molding Quotation

Profile End Quotation				
Manufacturer	Manufacturing Process	Material	Surface Finish	Color
ATP Molding	CNC	Al 6061-T6	Anodized	Matte Black, Orange
Quantity	Lead Time	Unit Price	Total Price	Shipping
2	12 days	\$260	\$520	\$100
10	14 days	\$200	\$2000	\$230
30	20 days	\$180	\$5400	\$345



## 4.2 Knee and Calf Supports

The knee and calf supports will be manufactured at SunPe Manufacturing in Zhongshan, Guangzhou, China, see table 4.3 and 4.4 for quotation. The manufacturable knee support design requires investing \$142 in a master model and \$196 in a silicone cavity mold for every 20 manufactured units. Each knee support will cost \$31.5. The total price and time for manufacturing and shipping 20 knee support units is 18 days and \$1269. One pair of knee supports will cost **\$126.9** which is below the company budget of \$200.

The manufacturable calf support design requires investing \$126 in a master model and \$170 in a silicone cavity mold for every 20 manufactured units. Each knee support will cost \$28.3. The total price and time for manufacturing and shipping of 20 calf support units is 18 days and \$1163. One pair of calf supports will cost **\$116.3** which is below the company budget of \$170. See Appendix B.3 for authentic quotation.

**Table 4.3:** Knee Support; SunPe Quotation

Knee Support Quotation				
Manufacturer	Manufacturing Process	Material	Surface Finish	Color
SunPe	Vacuum Casting	PUR 8150	Smooth	Matte Black
Quantity	Lead Time	Unit Price	Total Price	Shipping
20	8 days	\$31.5	\$629	\$302
Tooling Quotation				
Manufacturer	Description	Quantity	Lead Time	Tool Price
SunPe	Master Model (ABS)	1	2 days	\$142
SunPe	Mold (Silicone)	1	3 days	\$196

**Table 4.4:** Calf Support; SunPe Quotation

Calf Support Quotation				
Manufacturer	Manufacturing Process	Material	Surface Finish	Color
SunPe	Vacuum Casting	PUR 8150	Smooth	Matte Black
Quantity	Lead Time	Unit Price	Total Price	Shipping
20	8 days	\$28.3	\$565	\$302
Tooling Quotation				
Manufacturer	Description	Quantity	Lead Time	Tool Price
SunPe	Master Model (ABS)	1	2 days	\$126
SunPe	Mold (Silicone)	1	3 days	\$170

### 4.3 Seat Post and Arm

The seat post and arm will be manufactured at SuNPe Manufacturing in Zhongshan, Guangdong, China, see table 4.5 and 4.6 for quotations. The parts are manufactured through sheet metal and standard bicycle tubing, requiring no tooling investment.

The total price and time for manufacturing and shipping is \$543/unit and 11 days for 1 unit, \$334/unit and 16 days for 5 units and **\$234/unit** and 19 days for 15 units. \$234/unit when purchasing 15 units is above the company budget of \$200. See Appendix B.6 for authentic quotation.

**Table 4.5:** Seat Post Quotation

Seat Post Quotation				
Manufacturer	Manufacturing Process	Material	Surface Finish	Color
SuNPe Manufacturing	Sheet Metal, Welding	Al 6061-T6	Powder Coating	Matte Black
Quantity	Lead Time	Unit Price	Total Price	Shipping
1	6 days	\$200	\$200	\$100
5	11 days	\$130	\$650	\$230
15	14 days	\$98	\$1470	\$340

**Table 4.6:** Seat Arm Quotation

Seat Arm Quotation				
Manufacturer	Manufacturing Process	Material	Surface Finish	Color
SuNPe Manufacturing	Sheet Metal, Welding	Al 6061-T6	Powder Coating	Matte Black
Quantity	Lead Time	Unit Price	Total Price	Shipping
1	6 days	\$243	\$243	\$100
5	11 days	\$158	\$790	\$230
15	14 days	\$113	\$1695	\$340

# 5

## Discussion

This chapter discusses the research findings and what they implicate. This includes comparing different views, arguments, factors and causes. This chapter will answer what the results mean and whether or not they answered the initial research questions. The methodology used to gain these results will be criticized for its strengths and weaknesses.

Redesigning a conceptual design for manufacturability and establishing corresponding manufacturers required theory on DFM, manufacturing processes and manufacturer correspondence. Whether enough necessary theory was gathered in chapter 2 is debatable. DFM is a large and ever growing field of research. Boothroyd and Dewhurst have the majority of available literature on DFM, but the field might be too big for them to provide detailed guiding on designing specific parts or manufacturing processes. Guidelines such as making the design modular, multi-functional, using standard components and few parts can be thought of as intuitive or too general. Yet, this thesis shows that these guidelines are essential for lowering cost and easing manufacturing. DFM involves changing a products design in order to facilitate the manufacturing process and lowering manufacturing costs. Certainly, considering manufacturing processes and materials early in a design phase can be economically beneficial.

Knowledge of as many manufacturing processes for different materials as possible might be one of the most valuable abilities for a product development engineer. An integral part of designing for manufacturability is the early selection of material, manufacturing process and the combination of the two. Redesigning Spike for manufacturability required an understanding of as many manufacturing processes as possible and selecting the most suitable processes based on Spike's parts, production quantity and company budget. Selecting manufacturing processes based on production quantity was possibly not the best premise for selection. The quantity will vary, and most likely be higher as time goes on. In a low volume market it is scary to invest in tooling equipment, but can be worth it for exactly the reason of low volume production. Machining or milling parts instead of molding or casting

for every purchase order can economically damage the company over time. It may never allow the company to make higher returns of profit as these manufacturing costs are stagnant.

The main frame profile's conceptual design anticipated that standard tubes came in all dimensions. This was a naive assumption by the engineering team due to lack of manufacturing experience. Fortunately it led to the design of a custom cross sectional tube with adjustment implementations. Extrusion and die casting were the only manufacturing processes under consideration. More research could have been done to evaluate other manufacturing processes or to possibly find a standard tube of similar shape. The investment in extrusion and bending tooling proved to be more expensive than die cast tooling. Having the extrusion and bending in two separate toolings keeps open the possibility for manufacturing straight tubes. All though the main frame profile's manufacturable design is with a bend it was worth the extra cost. If the design were to change in the future and require a different or no bend, there is no need for further tooling investment. On the other hand the current manufacturable design is supposed to be final. The consideration of future design changes might mean the manufacturable design is not complete. Furthermore, investing in such tooling is a risk in a low volume production market. It takes the purchase of 15 units to pay off the tooling. A low volume production company must be certain of estimated sales and evaluate pay off before investing in tooling equipment.

The profile ends were an unexpected addition to the main frame profile. Welding a base plate at the end of an extruded custom tube seemed diminishing. Extruding a custom tube allowed for a transition fit for profile end caps. This gave the Spike the possibility to be disassembled. The only manufacturing processes considered for the profile end was CNC machining. Die casting should also have been considered as a viable manufacturing process. All though it would require an expensive investment in tooling, the price per profile end through CNC machining is high. Yet, the total price for the main profile and profile ends are below the company budget.

Manufacturable polymer designs require a faster manufacturing process decision than metals. A variety of manufacturing processes were considered for the knee and calf supports. Different manufacturing process requirements demanded an early decision for the redesign. Alternating BOMs and quotations with manufacturers gave insight on the manufacturability for the design. The decision to design the supports for vacuum casting could have been taken too fast and been too influenced by manufacturers quotations and comments. Vacuum casting is a process that requires a new mold every 20 units. This makes the manufacturing cost stagnant for every 20 units. If knee and calf support costs must be lowered in the future, the design will again have to be redesigned as it is designed specifically for vacuum casting. Yet, the supports robust design for vacuum casting implements support and multi-functional features and is below the company budget.

The seat post's conceptual design was not manufacturable and divided into two parts, seat arm and seat post. Sheet metal bending and standard bicycle tubing were chosen as manufacturing processes for the design. It is not sure whether these manufacturing methods are correct for the parts, but they were certainly the easiest based on part requirements. More manufacturing processes could have been considered. Molding or casting were never considered or quoted due to low volume production. The results showed a total price above the company budget which is applicable considering the seat post was divided into two parts.

All manufacturable designs started with the selection of a manufacturing process and designed thereafter based on manufacturing requirements, factory limitations and advice from manufacturers. It is difficult to pinpoint when DFM practices should be implemented in product development stages. The main frame profile and knee and calf support chapters showed how to make manufacturable parts out of non-manufacturable conceptual designs. Both parts already had rough conceptual designs to work on. Having to redesign conceptual design is clearly cost ineffective. Whether DFM practices can be implemented at an earlier stage is unclear. Since the seat post conceptual design was dismissed that chapter showed how to make a manufacturable part strictly off selected manufacturing processes and part requirements. It can be argued that this diminished the creativity of the design as it was locked to specific manufacturing processes.

Approaching the design in a more flexible matter could prove beneficial. Instead of choosing a single manufacturing process several could be considered for the design. Keeping requirements and design options flexible for as long as possible during the design phase could yield a better spread of results for each part. This kind of research requires experience in manufacturing processes.

Start-up companies with low volume production often have newly qualified engineers with a lack in manufacturing knowledge. Therefore comments and guidance from manufacturers through BOM's and quotations can be very helpful for designing a part for manufacturability. It is important to note that too much trust cannot be given to the manufacturers. They are a customer just as much as the buyer and can therefore be devious in their feedback. For a sketch design to evolve a design engineer should have defined evaluations of manufacturing processes and know their criteria before designing.

# 6

## Conclusion

Certain manufacturing process requirements pose drastic demands for a design. Any design should consider and evaluate manufacturing processes and requirements as early as the design phase allows. This thesis clearly shows that a design should never reach conceptual design without implementing DFM practices or considering manufacturing processes. Implementing DFM practices and selecting a manufacturing processes for a design should happen after the design sketch phase, but the exact correct implementation time will vary depending on the part. Selecting the correct manufacturing process for a part requires a parts production volume, functionality demands, dimensional and surface requirements and design sketches. The manufacturability of a design should never be concluded without consent from an authentic manufacturer.

Low volume production affects the selection of manufacturing processes. Low volume production eliminates certain manufacturing processes and introduces others. For a production of 15 units, few tooling equipment are worth an investment. Injection molding for polymers and metal casting can be considered when production quantity is higher. Certain manufacturing processes are suited for low volume manufacturing such as vacuum casting and CNC machining. Manufacturers opinions are of great value for selecting manufacturing process based on quantity and shape.

The Spike was completed successfully solely due to the impact of DFM. For future product development cases in the company, DFM will be implemented from the beginning of the design stage. In this case, DFM was implemented in the later stages, forcing redesign. This thesis proves that consistently applying DFM principles will generate a successful product that may be mass produced cost effectively and brought to market.

## 6.1 Further Research

This thesis followed the product development case of Spike. All though Spike's design was completed and made manufacturable, there are still certain areas that were not covered or require more research.

This thesis showed one way of generating a manufacturable design by selecting single manufacturing processes. Further research must be carried out on a more flexible approach. Considering multiple viable manufacturing processes for a design for as long as possible.

- Develop a manufacturable design based on multiple manufacturing processes.

A big part of manufacturability is the selection of investing in tooling equipment. Which quantities and requirements must be reached for a low volume production to invest in tooling with economical gain? This thesis presented multiple manufacturing processes relevant for low volume production. Further research must be performed to obtain a clear overview of which manufacturing processes are best suited for low volume production. Topics for further research are;

- Tooling equipment investment based on *quantity* and *economical gain*.
- Overview of manufacturing processes based on production *quantity* and *material*.

# Bibliography

- [1] Boothroyd D G. DFMA. 1985; Available from: <http://www.dfma.com/backgrd.asp>.
- [2] Boothroyd G, Dewhurst P, Knight W. Product Design for Manufacture and Assembly. CRC Press. 2011; 3rd:670.
- [3] Logo; 2016. <http://www.exerotech.com>.
- [4] Minimum Viable Product: a guide; 2009. [http://cache.boston.com/multimedia/sports/bigshots/paralympics\\_2010/bs19.jpg](http://cache.boston.com/multimedia/sports/bigshots/paralympics_2010/bs19.jpg).
- [5] 2010 Paralympics in Vancouver; 2010. [https://gfx.nrk.no/akkH1F2DhnLyKMgBF5texQQEfF0LYjv-e-U01FrW\\_VFA](https://gfx.nrk.no/akkH1F2DhnLyKMgBF5texQQEfF0LYjv-e-U01FrW_VFA).
- [6] Fon J Berg. Steering system for cross-country sit-skis; 2016.
- [7] Exero Technologies Database. Google Drive; 2017.
- [8] Chang TC, Wysk RA, Wang HP. Computer-Aided Manufacturing. Prentice Hall. 1998; Second Edition:596–598.
- [9] Dictionary B. Manufacturing. 2018; Available from: <http://www.businessdictionary.com/definition/manufacturing.html>.
- [10] BBC. Shaping by Reforming; 2014. [Online; accessed March 27, 2018]. <http://www.bbc.co.uk/schools/gcsebitesize/design/resistantmaterials/processtechniquesrev8.shtml>.
- [11] SME. Extrusion; 2010. [Online; accessed March 29, 2018]. <https://www.sme.org/WorkArea/DownloadAsset.aspx?id=73746>.
- [12] Oberg E, Jones FD, Horton HL, Ryffel HH. Machinery's Handbook. New York: Industrial Press. 2000; 26th:13–16.
- [13] Wikimedia. Extrusion plastic; 2006. [Online; accessed March 29, 2018]. [https://en.wikipedia.org/wiki/Plastics\\_extrusion#/media/File:Extruder\\_with\\_sheet\\_die.jpg](https://en.wikipedia.org/wiki/Plastics_extrusion#/media/File:Extruder_with_sheet_die.jpg).



- 
- [14] Degarmo JTKRA E Paul; Black. Materials and Processes in Manufacturing. Wiley. 2003;9th:60.
- [15] Dynacast. Die Casting; 2017. [Online; accessed April 29, 2018]. <https://www.dynacast.com/die-casting>.
- [16] BBC. Shaping by Reforming. BBC Inc. 2014;Available from: <http://www.bbc.co.uk/schools/gcsebitesize/design/resistantmaterials/processtechniquesrev8.shtml>.
- [17] Part C. Die Casting; 2017. [Online; accessed April 29, 2018]. <http://www.custompartnet.com/wu/die-casting>.
- [18] Thomas. CNC Milling; 2018. [Online; Accessed April 27, 2018]. <https://www.thomasnet.com/about/cnc-milling-51276103.html>.
- [19] Hurco. 5-axis CNC machine; 2017. [Online; accessed April 27, 2018]. <http://www.hurco.com/en-gb/machine-tools/machining-centres/5-axis-vertical/pages/swivel-head.aspx>.
- [20] American Machinist. 5-axis CNC machine; 2017. [Online; accessed April 27, 2018]. URL<http://www.americanmachinist.com/shop-operations/5-reasons-5-axis-cnc-machine-actually-good-your-shop>.
- [21] Benson S. Bending Basics: The Fundamentals of heavy bending. The Fabricator. 2013;Available from: <https://www.thefabricator.com/article/bending/bending-basics-the-fundamentals-of-heavy-bending>.
- [22] Todd RH, Allen DK, Alting L. Manufacturing Processes Reference Guide. Industrial Press, Inc. 1994;.
- [23] Renishaw. Vacuum Casting Technology; 2018. [Online; Accessed April 27, 2018]. <http://www.renishaw.com/en/our-vacuum-casting-technology--15268>.
- [24] Throne JL. Understanding Thermoforming. Hanser Gardner Publications. 1999;.
- [25] Cannonshelly. Vacuum Forming; 2018. [Online; Accessed April 27, 2018]. <http://www.cannonshelley.com/en/D-Thermof.-Applications/vacuum-forming.html#>.
- [26] McClatchey P. Surface Finish. SAF Inc. 2015;Available from: <https://www.saf.com/how-to-specify/how-to-decide-between-anodizing-painting-and-powder-coating/>.
- [27] Gillespie LK. Deburring and edge finishing handbook. SME. 1999;SME:7-11.
- [28] Sheasby PG, Pinner R. The Surface Treatment and Finishing of Aluminum and its Alloys. 2. ASM International Finishing Publications. 2001;6th ed.:3-9.

- [29] Renishaw. Anodic Oxidization Process; 2011. [Online; Accessed May 4, 2018]. <http://www.misumi-techcentral.com/tt/en/surface/2011/07/086-what-is-anodizing-anodic-oxidization-process.html>.
- [30] Direct P. HIPS – High Impact Polystyrene; 2018. [Online; accessed May 30, 2018]. [http://www.plasticsdirect.co.uk/html/HIPS\\_47.html](http://www.plasticsdirect.co.uk/html/HIPS_47.html).
- [31] Guandong; 2012. [https://upload.wikimedia.org/wikipedia/commons/thumb/e/e3/Guangdong\\_in\\_China\\_%28%2Ball\\_claims\\_hatched%29.svg/1200px-Guangdong\\_in\\_China\\_%28%2Ball\\_claims\\_hatched%29.svg.png](https://upload.wikimedia.org/wikipedia/commons/thumb/e/e3/Guangdong_in_China_%28%2Ball_claims_hatched%29.svg/1200px-Guangdong_in_China_%28%2Ball_claims_hatched%29.svg.png).
- [32] Xihuan; 2006. [http://news.xinhuanet.com/english/2006-02/04/content\\_4133837.htm](http://news.xinhuanet.com/english/2006-02/04/content_4133837.htm).
- [33] SuNPe. SuNPe - Your Professional and Reliable Supplier; 2018. [Online; accessed May 30, 2018]. <http://www.sunpe.com/>.
- [34] APT. APT Molding Amazing Prototype and Tooling; 2018. [Online; accessed May 30, 2018]. <http://www.aptmold.com/>.

# Appendix

# A

## Bills of Materials: Spike

### A.1 Polymer Parts

No. 系号	Drawing Name 图档名称	Process工艺	Material 材料	Finishing 后处理	Color 颜色	Qty 数量
	<b>Polymer Parts</b>					
1	Knee support	CNC	ABS	Smooth	Matte White	2
2	Calf Support Left	CNC	ABS	Smooth	Matte White	1
3	Calf Support Right	CNC	ABS	Smooth	Matte White	1
4	Support brackets	CNC	ABS	Smooth	Matte White	8
1.1	Knee support	Vacuum Forming	ABS	Smooth	Matte White	2
2.1	Calf Support Left	Vacuum Forming	ABS	Smooth	Matte White	1
3.1	Calf Support Right	Vacuum Forming	ABS	Smooth	Matte White	1
4.1	Support brackets	Vacuum Forming	ABS	Smooth	Matte White	8
1.2	Knee support	Vacuum Casting	PUR	Smooth	Matte White	2
2.2	Calf Support Left	Vacuum Casting	PUR	Smooth	Matte White	1
3.2	Calf Support Right	Vacuum Casting	PUR	Smooth	Matte White	1
4.2	Support brackets	Vacuum Casting	PUR	Smooth	Matte White	8

## **A.2 All parts**

A. Bills of Materials: Spike

Drawing Name 图档名称	Material材料	Surface Treatment	Color 颜色	Qty 数量	SunPe Prototype					
					Hongkong					
					Price 1 pcs	Price 5 pcs	Price 15 pcs	Price 35 pcs	Process	
<b>Sub-Assembly Seat</b>										
Seat frame left	Al 6061-T6	Anodize	Matte Black	1	€ 196.00	€ 172.50	€ 157.50	€ 140.00	Sheet metal	
Seat frame right	Al 6061-T6	Anodize	Matte Black	1	€ 196.00	€ 172.50	€ 157.50	€ 140.00	Sheet metal	
Adjustment frame	Al 6061-T6	Anodize	Matte Black	1	€ 153.00	€ 141.00	€ 133.00	€ 118.00	Sheet metal	
Seat left bracket	Al 6061-T6	Anodize	Matte Black	1	€ 90.00	€ 60.20	€ 47.00	€ 40.00	Sheet metal	
Seat right bracket	Al 6061-T6	Anodize	Matte Black	1	€ 90.00	€ 60.20	€ 47.00	€ 40.00	Sheet metal	
Seat center shell	PUR	Smooth	Matte Black	1	€ 120.00	€ 115.00	€ 28.00		Vacuum casting PU 8150	
Seat shell left	PUR	Smooth	Matte Black	1	€ 131.00	€ 123.00	€ 40.80		Vacuum casting PU 8150	
Seat shell right	PUR	Smooth	Matte Black	1	€ 131.00	€ 123.00	€ 40.80		Vacuum casting PU 8150	
<b>Sub-Assembly Seat arm</b>										
Seat arm latch	Al 6061-T6	Anodize	Matte Black	1	€ 85.00	€ 54.00			Sheet metal	
Seat arm lock bracket	Al 6061-T6	Anodize	Matte Black	1	€ 43.00	€ 31.00			Sheet metal	
Seat arm sheet bracket head	Al 6061-T6	Anodize	Matte Black	1	€ 28.00	€ 19.00			Sheet metal	
Seat arm sheet bracket	Al 6061-T6	Anodize	Matte Black	1	€ 87.00	€ 54.00			Sheet metal	
<b>Sub-Assembly Seat post</b>										
Bracket post	Al 6061-T6	Anodize	Matte Black	1	€ 22.00	€ 22.00			CNC	
Tube big	Al 6061-T6	Anodize	Matte Black	1	€ 89.00	€ 54.00			CNC & Lathe	
Tube small	Al 6061-T6	Anodize	Matte Black	1	€ 89.00	€ 54.00			CNC & Lathe	
<b>Sub-Assembly Slider front and rear</b>										
Slider front	Al 6061-T6	Anodize	Matte Black	1	€ 340.00	€ 260.00	€ 217.00	€ 180.00	Sheetmetal, Bending	
Slider rear	Al 6061-T6	Anodize	Matte Black	1	€ 340.00	€ 260.00	€ 217.00	€ 180.00	Sheetmetal, Bending	
<b>Other parts</b>										
Main Frame Profile	Al 6061-T6	Powder coating	Matte Black	1	€ 1,093.00	€ 146.00			Mould, Sheet metal	
Profile end	Al 6061-T6	Anodize	Matte Black	2	€ 230.00	€ 169.00			CNC/Laser/EDM	
Calf Support	PUR	Smooth	Matte Black	2	€ -	€ -	€ 37.00		Vacuum casting PU 8150	
Knee Support	PUR	Smooth	Matte Black	2	€ -	€ -	€ 42.00		Vacuum casting PU 8150	
Mud guard right	PLA	Smooth	Matte Black	2	€ 38.00	€ 31.00			Vacuum casting PU 8150	
Mud guard left	PLA	Smooth	Matte Black	2	€ 77.00	€ 31.00			Vacuum casting PU 8150	
					€ 3,553.00	€ 2,090.40	€ 2,731.00	€ 2,050.00		
		Shipping			€ 273.00	€ 1,008.00	€ 2,238.00	€ 2,454.00		
∨		Lead time			21	25	28	31		

# B

## Quotations

### B.1 Main Frame Profile



# APT Mold Manufacturing Co.,Ltd.

Address 56 Hua Shi Xia street, Shenyongcun, Zhongshan Torch Development Zone, Guangdong Province 528437, People's Republic of China

Website [www.aptmold.com](http://www.aptmold.com)

Contact Email: [enquiry@aptmold.com](mailto:enquiry@aptmold.com) | Tel: +86 188 1424 6085



# APT Mold

Amazing Prototype and Tooling

Company <b>Ewrotech</b>	
Contact	Andrie Haag Johnson
Email	<a href="mailto:andrie@ewrotech.com">andrie@ewrotech.com</a>

Quote number	1803048-Rev3
Quote Date	2018/6/4
Valid until:	2018/6/4
Currency	USD

Parts Quotation				Tooling Quotation										
Item #	Part name / Drawing No.	Process	Part Material	Part Color	Part finish	Order Batch Qty	Lead time	Part Unit Price	Total Part Price	Cavity	Description	Tool Lead Time	Remark	Tool Price
1	Main frame profile-v4	Extrusion, Bending and Welding	6061 T6 Aluminium	Natural	Deburred	1	TBD	Free	NA	1	Extrusion Tool and Bending tool Tool Life Time: 50,000	24 days	/	2,200.00
						5		62.00	310.00					
						15		32.00	480.00					
						35		22.00	770.00					
								Shipment cost for 5 pcs 180.00						
								Total Amount for 5 pcs 490.00						
								Shipment cost for 15 pcs 250.00						
								Total Amount for 15 pcs 730.00						
								Shipment cost for 35 pcs 300.00						
								Total Amount for 35 pcs 1070.00						1 Set 2,200.00

<p>Acceptance of our quotation or the placing of an order shall constitute acceptance of our terms &amp; conditions: <a href="http://www.aptmold.com/wp-content/uploads/2017/08/APT-Mold-Manufacturing-Co.Ltd.-Terms-Conditions.pdf">http://www.aptmold.com/wp-content/uploads/2017/08/APT-Mold-Manufacturing-Co.Ltd.-Terms-Conditions.pdf</a></p>		<p>Tooling and Molding Notes</p> <ul style="list-style-type: none"> <li>Moldbase and mold components will follow normal Local standard unless otherwise specified.</li> <li>Special tolerance requirement should be informed before the order confirmation, otherwise normal tolerance will apply.</li> <li>Above quoted molds are Non-export mold(s).</li> </ul>		<p>Payment terms Notes</p> <ul style="list-style-type: none"> <li>Invoice upon receipt of Customer PO, start up project after receiving 100% upfront payment.</li> <li>Prices exclude VAT. You may be required to pay VAT and Import Duties in your own Country.</li> </ul>	
<p>General Notes</p> <ul style="list-style-type: none"> <li>Quotation is based on the current information. If any change, the prices require an update.</li> <li>Tooling Lead-time (T1) starts from DFM (Design for Manufacturing) confirmation.</li> <li>5 parts of samples for approval plus shipment are included.</li> <li>Tool price includes first inspection report - supplied upon request. (NOT FULL ISIR)</li> <li>If no moulding order received over 18 months since last order, the mould could be scrapped by APT Mold if no reply received within 1 month upon our enquiry about the disposal method of the mould.</li> </ul>					

<p>Sales contact</p> <p>Name Wilson Lin          Skype <a href="mailto:wilson.lin@aptmold.com">wilson.lin@aptmold.com</a>          Email <a href="mailto:wilson.lin@aptmold.com">wilson.lin@aptmold.com</a>          Date May 4, 2018</p>		<p>Please sign and date below if you wish APT Mold to proceed with your job</p>	
		<p>I confirm that I am an authorised signatory of the client company.</p>	

## **B.2 Profile End**

# APT Mold Manufacturing Co.,Ltd.

**Address** 56 Hua Shi Xia street, Shenyongoun, Zhongshan Torch Development Zone, Guangdong Province 528437, People's Republic of China

**Webseite** [www.aptmold.com](http://www.aptmold.com)

**Contact Email:** [enquiry@aptmold.com](mailto:enquiry@aptmold.com) | **Tel:** +86 188 1424 6095



# APT Mold

Amazing Prototype and Tooling

Quote to Customer	
<b>Company</b> Exvotech	<b>Phone</b> +47 905 13 537
<b>Contact</b> Andre Haig Johnson	<b>Address</b> Nedre Moellenberg Gate 25B, Trondheim 7014, Norway
<b>Email</b> <a href="mailto:andrie@exvotech.com">andrie@exvotech.com</a>	

<b>Quote number</b> 1803048-Rev6
<b>Quote Date</b> 2018/5/25
<b>Valid until:</b> 2018/6/25
<b>Currency</b> USD

## Prototype Quotation

Item #	Part name / Drawing No.	Process	Part Material	Part Color	Part finish	Remark	Order Batch Qty	Lead time	Part Unit Price	Total Part Price
1	Profile end-v5	CNC Machining	6061 T6 Aluminum	Black	anodized matte	/	10 30	14 days 20 days	200.00 180.00	2,000.00 5,400.00
<b>Shipment cost</b> Not included										<b>Total Account</b> TBD

**Acceptance of our quotation or the placing of an order shall constitute acceptance of our terms & conditions:** <http://www.aptmold.com/wp-content/uploads/2017/09/APT-Mold-Manufacturing-Co.Ltd.-Terms-Conditions.pdf>

### General Tolerances Notes

- CNC (Metals): DIN ISO 2768 fine | CNC (Plastics): DIN ISO 2768 medium
- Vacuum casting: between +/- 0.2mm or 0.15% (depend on part size)
- SLA: +/-0.1mm<100mm or +/-0.2mm (100mm to 200mm)

### Payment terms Notes

- Prototype Invoice upon receipt of Customer PO. Production begins after payment receiving 100% upfront payment.
- A 4% fee will be applied to orders that are paid via PayPal.
- Prices exclude VAT. You may be required to pay VAT and Import Duties in your own Country.
- Delivery time: about 3-4 days (Express)

### Sales contact

**Name** Wilson Lin  
**Skype** [wilson.lin@aptmold.com](https://www.skype.com/people/wilson.lin@aptmold.com)  
**Email** [wilson.lin@aptmold.com](mailto:wilson.lin@aptmold.com)  
**Date** May 25, 2018

Please sign and date below if you wish APT Mold to proceed with your job

I confirm that I am an authorised signatory of the client company.

### **B.3 Knee and Calf Supports**


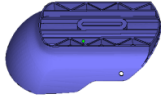
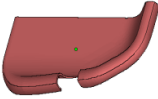

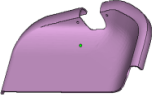


# Prototypes Quotation

Quotation No.:SP18SA006-20180519A

Client No.: SP18SA006  
 Client: Exero Technologies AS  
 Phone.: +47 905 13 537  
 Fax.:  
 Contact: Andre Haig Johnsen  
 Website: <http://www.exerotech.com>  
 E-mail: [andre@exerotech.com](mailto:andre@exerotech.com)

Provider: SUNPE LIMITED  
 Address: No.70 Tongxing Xi Rd, Dongsheng town,  
 Zhongshan city, GuangDong, 528415, P.R.China,  
 Tel.: +86 (0) 760 22825560,22825561,22825562,22825563  
 Fax.: +86 (0) 760 22211992  
 Contact: Daisy Zheng  
 Website: <http://www.sunpe.com>  
 E-mail: [RP\\_11@sunpe.com](mailto:RP_11@sunpe.com), [sunpe.rp011@gmail.com](mailto:sunpe.rp011@gmail.com)

1. Prototypes Cost					
Item No.	IGES/STEP/STL file name	Material	technics	Qty	Total cost
1	Calf support-v5	ABS	CNC	1	EUR 108
		Silicone	Mould	1	EUR 146
		PU 8150	Vacuum Casting	20	EUR 486
		<b>Size:</b> Max X:111.798 mm Max Y:97.280 mm Max Z: 248.564 mm  <b>Volume:170000 mm3</b> After treatment: Black, Smooth			
2	Knee support - Molded_rev3	ABS	CNC	1	EUR 122
		Silicone	Mould	1	EUR 169
		PU 8150	Vacuum Casting	20	EUR 541
		<b>Size:</b> Max X:148.432 mm Max Y:70.592 mm Max Z: 247.813 mm  <b>Volume:228161 mm3</b> After treatment: Black, Smooth			
3	Seat left	ABS	CNC	1	EUR 122
		Silicone	Mould	1	EUR 209
		PU 8150	Vacuum Casting	20	EUR 486
		<b>Size:</b> Max X:156.796 mm Max Y:82.076 mm Max Z: 316.199 mm  <b>Volume:137863 mm3</b> After treatment: Black, Smooth			
4	Seat middle	ABS	CNC	1	EUR 85
		Silicone	Mould	1	EUR 135
		PU 8150	Vacuum Casting	20	EUR 338
		<b>Size:</b> Max X:120.000 mm Max Y:84.642 mm Max Z: 315.913 mm  <b>Volume:106605 mm3</b> After treatment: Black, Smooth			
5	Seat right	ABS	CNC	1	EUR 122
		Silicone	Mould	1	EUR 209
		PU 8150	Vacuum Casting	20	EUR 486
		<b>Size:</b> Max X:156.800 mm Max Y:82.076 mm Max Z: 316.199 mm  <b>Volume:137802 mm3</b> After treatment: Black, Smooth			
<b>Total Prototyping Cost:</b>					<b>EUR 3,764</b>



## Prototypes Quotation

Quotation No.:SP18SA006-20180519A

Client No.: SP18SA006  
 Client: Exero Technologies AS  
 Phone.: +47 905 13 537  
 Fax.:  
 Contact: Andre Haig Johnsen  
 Website: <http://www.exerotech.com>  
 E-mail: [andre@exerotech.com](mailto:andre@exerotech.com)

Provider: SUNPE LIMITED  
 Address: No.70 Tongxing Xi Rd, Dongsheng town,  
 Zhongshan city, GuangDong, 528415, P.R.China,  
 Tel.: +86 (0) 760 22825560,22825561,22825562,22825563  
 Fax.: +86 (0) 760 22211992  
 Contact: Daisy Zheng  
 Website: <http://www.sunpe.com>  
 E-mail: [RP\\_11@sunpe.com](mailto:RP_11@sunpe.com), [sunpe.rp011@gmail.com](mailto:sunpe.rp011@gmail.com)

2. Logistic Fee (Delivered by DHL Express Airway)					
Item No.	IGES/STEP/STL file name	Gross volume	Destination	Qty	Total volume
1'5	Item 1 to item 5		Norway	100	238kg
				Sum:	238kg
				<b>Estimated Freight:</b>	<b>EUR 1,311</b>
DHL: Light weight cargo's freight based on package's gross volume.					
3. Time					
	Prototypes+After treatment+Painting (working days)	DHL collect parcel (working days)	Delivery to destination (working days)	Total (working days)	
	10	1	2	13	
4. Summary					
	Prototypes+After treatment+Painting EUR 3.764	DHL Freight EUR 1.311	Total Expense <b>EUR 5,075</b>	Total period <b>13</b>	
5. Others					
5.1.	<b>Knowledge property right</b>	Service provider should protect the knowledge property right of client, and keep secret for client.			
5.2.	<b>Customs duty and other local tax in destination country</b>	Client pay customs duty and other local tax in destination country, if happened.			
5.3.	<b>Period of validity for quotation</b>	One calendar month after quotation issued.			

## **B.4 Knee and Calf Support Conceptual Design CNC Milling**

## Star Rapid Limited

Room 4, 11/F, Tern Plaza, 5 Cameron Road, Tsim Sha Tsui,  
Kowloon, Hong Kong  
Tel.: +852 28494 555 | Fax: +852 28494 556  
Email: enquiry@starrapid.com | www.starrapid.com

## QUOTE

Number: P720612-R2  
Date: 19-Dec-2017  
Valid until: 14-Jan-2018

### Quote To

Exero Technologies AS  
Andre Haig Johnsen ( andre@exerotech.com )  
Tel: +47 905 13 537  
  
,  
Norway

### Details

Sales: Alina Huang  
Email: alina.huang@starrapid.com  
  
Currency: Euro  
Terms: Pay in advance  
Ship Via: Best way  
  
Ref.:

Item #	Item Name	Description	Lead Time	Quantity	Unit Price	Amount
001	Main tube 760x40x3.5	Process: Cut and bore Part Material: Aluminum Surface Finish: Anodising Surface Color: Satin Black  <b>Remarks:</b> Outer diameter 40mm, Inner diameter 32mm pipe to machine length and features.  Outer diameter and inner diameter won't be machined.	22-25 Day(s)	5	€393.72	€1,968.60
			33-36 Day(s)	20	€335.58	€6,711.60
002	Trampa Vertigo truck plate 6mm	Process: CNC/Laser cutting Part Material: Aluminum Surface Finish: Anodising Surface Color: Satin Black Remarks:	22-25 Day(s)	10	€50.85	€508.50
			33-36 Day(s)	40	€26.60	€1,064.00
003	Extender tube 500x40x3.5	Process: Cut and bore Part Material: Aluminum Surface Finish: Anodising Surface Color: Satin Black  <b>Remarks:</b> Outer diameter 30mm, Inner diameter 27mm pipe to machine length and features.  Inner diameter won't be machined.	22-25 Day(s)	5	€381.99	€1,909.95
			33-36 Day(s)	20	€301.94	€6,038.80
004	Calf tube 240x48x2.5	Process: Cut and bore Part Material: Aluminum Surface Finish: Anodising Surface Color: Satin Black Remarks:	22-25 Day(s)	5	€187.74	€938.70
			33-36 Day(s)	20	€150.19	€3,003.80



Item #	Item Name	Description	Lead Time	Quantity	Unit Price	Amount
005	Knee tube 270x48x2.5	Process: Cut and bore Part Material: Aluminum Surface Finish: Anodising Surface Color: Satin Black Remarks:	22-25 Day(s)	5	€187.74	€938.70
			33-36 Day(s)	20	€150.19	€3,003.80
006	48mm Tube arm M4	Process: CNC/Laser Part Material: Aluminum Surface Finish: Anodising Surface Color: Satin Black Remarks:	22-25 Day(s)	40	€27.90	€1,116.00
			33-36 Day(s)	160	€21.12	€3,379.20
007	Seat vertical tube 200x30x2.0	Process: Cut and bore and Laser/EDM Part Material: Aluminum Surface Finish: Anodising Surface Color: Satin Black Remarks:	22-25 Day(s)	5	€179.91	€899.55
			33-36 Day(s)	20	€128.03	€2,560.60
008	Seat tube 250x48x2.5	Process: Cut and bore Part Material: Aluminum Surface Finish: Anodising Surface Color: Satin Black Remarks:	22-25 Day(s)	5	€137.67	€688.35
			33-36 Day(s)	20	€103.78	€2,075.60
009	25mm Seat vertical tube suppor	Process: Cut and bore Part Material: Aluminum Surface Finish: Anodising Surface Color: Satin Black Remarks:	22-25 Day(s)	5	€82.40	€412.00
			33-36 Day(s)	20	€59.97	€1,199.40
010	Seat post 200x25x2.0	Process: Cut and bore Part Material: Aluminum Surface Finish: Anodising Surface Color: Satin Black Remarks:	22-25 Day(s)	5	€91.26	€456.30
			33-36 Day(s)	20	€62.58	€1,251.60
011	Knee support	Process: CNC Part Material: ABS- Surface Finish: Smooth+Painting Surface Color: Satin Dark Orange Remarks:	22-25 Day(s)	10	€204.73	€2,047.30
			33-36 Day(s)	40	€176.44	€7,057.60

Item #	Item Name	Description	Lead Time	Quantity	Unit Price	Amount
012	Calf support	Process: CNC Part Material: ABS- Surface Finish: Smooth+Painting Surface Color: Satin Dark Orange Remarks:	22-25 Day(s)	10	€158.86	€1,588.60
			33-36 Day(s)	40	€141.57	€5,662.80
013	Seat adjuster base plate	Process: Cut and bore Part Material: Aluminum Surface Finish: Anodising Surface Color: Satin Black Remarks:	22-25 Day(s)	5	€19.56	€97.80
			33-36 Day(s)	20	€13.04	€260.80
014	Seat adjuster bottom 50x30x3	Process: CNC Part Material: Aluminum Surface Finish: Anodising Surface Color: Satin Black Remarks:	22-25 Day(s)	5	€67.79	€338.95
			33-36 Day(s)	20	€56.06	€1,121.20
015	Seat adjuster top 60x40x3	Process: CNC Part Material: Aluminum Surface Finish: Anodising Surface Color: Satin Black Remarks:	22-25 Day(s)	5	€100.39	€501.95
			33-36 Day(s)	20	€82.13	€1,642.60
016	Threaded block for M4	Process: CNC Part Material: Aluminum Surface Finish: Anodising Surface Color: Satin Black Remarks:	22-25 Day(s)	20	€9.13	€182.60
			33-36 Day(s)	80	€5.74	€459.20
017	Aluminum reinforcment diamond	Process: CNC Part Material: Aluminum Surface Finish: Anodising Surface Color: Satin Black Remarks:	22-25 Day(s)	5	€226.85	€1,134.25
			33-36 Day(s)	20	€178.61	€3,572.20
018	Plastic seat diamond shape	Process: CNC Part Material: ABS- Surface Finish: Smooth+Painting Surface Color: Satin Dark Orange Remarks:	22-25 Day(s)	5	€286.19	€1,430.95
			33-36 Day(s)	20	€216.82	€4,336.40

Item #	Item Name	Description	Lead Time	Quantity	Unit Price	Amount
019	Assembly	Process: welding Part Material: Surface Finish: Surface Color: Remarks:	22-25 Day(s)	5	€534.53	€2,672.65
			33-36 Day(s)	20	€469.34	€9,386.80
					<b>PARTS Total:</b>	<b>TBD</b>
					<b>GRAND Total:</b>	<b>TBD</b>

Thank you for the opportunity to quote. Please contact us if you have any enquiries concerning this quote.

**Please sign and return this quotation by email to confirm your order.**

Date

Signature

I confirm that I am an authorized signatory of the client company.

## NOTES

### 1. Terms & Conditions

Acceptance of our quotation or placing of an order shall constitute acceptance of our terms & conditions:  
[www.starrapid.com/terms-and-conditions/](http://www.starrapid.com/terms-and-conditions/)

### 2. Import

All importers are legally required to provide a valid HS Code for the purposes of importation into your own country.

### 3. Payment

#### 3.1 General

- Prices exclude VAT. You may be required to pay VAT and Import Duties in your own Country.
- A 4% fee will be applied to orders that are paid via PayPal.

#### 3.2 Tooling

- Proforma Invoice upon receipt of Customer PO, tooling project starts after receiving 50% upfront payment.
- If no approval received within 30 days after 1st sample shipment, the balance 50% is treated as payment due.
- If delay is caused due to customer's fault (e.g. design change & etc), the customer shall pay 50% balance amount and we carry on the order upon receipt of the 50% balance.

### 4. Other

#### 4.1 General

- Special tolerance requirement should be provided before the order confirmation, otherwise our standard tolerances will apply.
- The buyer is fully responsible for the correctness of the supplied data files. Star Rapid is not responsible to check for consistency between the files. When 3D CAD and 2D drawings are supplied, the parts will be manufactured according to the 3D CAD files. The 2D drawings will be used for general information and tolerances only.

#### 4.2 RP - Star Prototype's General Tolerances (finer tolerances are based on best effort only!)

- CNC (Metals): DIN ISO 2768 fine | CNC (Plastics): DIN ISO 2768 medium
- Vacuum casting: between +/- 0.2mm or 0.15% (depend on part size)
- SLA: +/- 0.1mm < 100mm or +/- 0.2mm (100mm to 200mm)
- SLS: +/- 0.2mm < 100mm or +/- 0.3mm (100mm to 200mm)

#### 4.3 Tooling & Molding incl. ECN

- Tooling lead-time (T1) starts from Design for Manufacturing (DFM) confirmation.
- 5 pcs/sets of samples for tool approval plus shipment are included.
- Tool price includes first inspection report - supplied upon request only. (NO FULL ISIR)
- If no molding order received over 18 months since last order, the mold may be scrapped by STAR if no reply received within 1 month upon our enquiry about the disposal method of the mold.

---

#### Star Rapid Limited

Room 4, 11/F, Tern Plaza, 5 Cameron Road, Tsim Sha Tsui, Kowloon, Hong Kong

Tel.: +852 28494 555

Fax: +852 28494 556

Email: [enquiry@starrapid.com](mailto:enquiry@starrapid.com) | [www.starrapid.com](http://www.starrapid.com)

#### Bank Information

HSBC (The Hong Kong and Shanghai Banking Corporation Ltd.)

Address: 1 Queen's Road, Central, Hong Kong

Account Name: Star Rapid Limited

Account Number: 817-890171-838

Swift Code: HSBCHKHKKH

Bank Code: 004817

## **B.5 Knee and Calf Support Conceptual Design Vacuum Casting**

## Star Rapid Limited

Room 4, 11/F, Tern Plaza, 5 Cameron Road, Tsim Sha Tsui,  
Kowloon, Hong Kong  
Tel.: +852 28494 555 | Fax: +852 28494 556  
Email: enquiry@starrapid.com | www.starrapid.com

## QUOTE

Number: P720612-R2  
Date: 19-Dec-2017  
Valid until: 14-Jan-2018

### Quote To

Exero Technologies AS  
Andre Haig Johnsen ( andre@exerotech.com )  
Tel: +47 905 13 537  
  
,  
Norway

### Details

Sales: Alina Huang  
Email: alina.huang@starrapid.com  
  
Currency: Euro  
Terms: Pay in advance  
Ship Via: Best way  
  
Ref.:

Item #	Item Name	Description	Lead Time	Quantity	Unit Price	Amount
001	Main tube 760x40x3.5	Process: Cut and bore Part Material: Aluminum Surface Finish: Anodising Surface Color: Satin Black  <b>Remarks:</b> Outer diameter 40mm, Inner diameter 32mm pipe to machine length and features.  Outer diameter and inner diameter won't be machined.	22-25 Day(s)	5	€393.72	€1,968.60
			33-36 Day(s)	20	€335.58	€6,711.60
002	Trampa Vertigo truck plate 6mm	Process: CNC/Laser cutting Part Material: Aluminum Surface Finish: Anodising Surface Color: Satin Black Remarks:	22-25 Day(s)	10	€50.85	€508.50
			33-36 Day(s)	40	€26.60	€1,064.00
003	Extender tube 500x40x3.5	Process: Cut and bore Part Material: Aluminum Surface Finish: Anodising Surface Color: Satin Black  <b>Remarks:</b> Outer diameter 30mm, Inner diameter 27mm pipe to machine length and features.  Inner diameter won't be machined.	22-25 Day(s)	5	€381.99	€1,909.95
			33-36 Day(s)	20	€301.94	€6,038.80
004	Calf tube 240x48x2.5	Process: Cut and bore Part Material: Aluminum Surface Finish: Anodising Surface Color: Satin Black Remarks:	22-25 Day(s)	5	€187.74	€938.70
			33-36 Day(s)	20	€150.19	€3,003.80

Item #	Item Name	Description	Lead Time	Quantity	Unit Price	Amount
005	Knee tube 270x48x2.5	Process: Cut and bore Part Material: Aluminum Surface Finish: Anodising Surface Color: Satin Black Remarks:	22-25 Day(s)	5	€187.74	€938.70
			33-36 Day(s)	20	€150.19	€3,003.80
006	48mm Tube arm M4	Process: CNC/Laser Part Material: Aluminum Surface Finish: Anodising Surface Color: Satin Black Remarks:	22-25 Day(s)	40	€27.90	€1,116.00
			33-36 Day(s)	160	€21.12	€3,379.20
007	Seat vertical tube 200x30x2.0	Process: Cut and bore and Laser/EDM Part Material: Aluminum Surface Finish: Anodising Surface Color: Satin Black Remarks:	22-25 Day(s)	5	€179.91	€899.55
			33-36 Day(s)	20	€128.03	€2,560.60
008	Seat tube 250x48x2.5	Process: Cut and bore Part Material: Aluminum Surface Finish: Anodising Surface Color: Satin Black Remarks:	22-25 Day(s)	5	€137.67	€688.35
			33-36 Day(s)	20	€103.78	€2,075.60
009	25mm Seat vertical tube suppor	Process: Cut and bore Part Material: Aluminum Surface Finish: Anodising Surface Color: Satin Black Remarks:	22-25 Day(s)	5	€82.40	€412.00
			33-36 Day(s)	20	€59.97	€1,199.40
010	Seat post 200x25x2.0	Process: Cut and bore Part Material: Aluminum Surface Finish: Anodising Surface Color: Satin Black Remarks:	22-25 Day(s)	5	€91.26	€456.30
			33-36 Day(s)	20	€62.58	€1,251.60
011	Knee support	Process: CNC Part Material: ABS- Surface Finish: Smooth+Painting Surface Color: Satin Dark Orange Remarks:	22-25 Day(s)	10	€204.73	€2,047.30
			33-36 Day(s)	40	€176.44	€7,057.60

Item #	Item Name	Description	Lead Time	Quantity	Unit Price	Amount
012	Calf support	Process: CNC Part Material: ABS- Surface Finish: Smooth+Painting Surface Color: Satin Dark Orange Remarks:	22-25 Day(s)	10	€158.86	€1,588.60
			33-36 Day(s)	40	€141.57	€5,662.80
013	Seat adjuster base plate	Process: Cut and bore Part Material: Aluminum Surface Finish: Anodising Surface Color: Satin Black Remarks:	22-25 Day(s)	5	€19.56	€97.80
			33-36 Day(s)	20	€13.04	€260.80
014	Seat adjuster bottom 50x30x3	Process: CNC Part Material: Aluminum Surface Finish: Anodising Surface Color: Satin Black Remarks:	22-25 Day(s)	5	€67.79	€338.95
			33-36 Day(s)	20	€56.06	€1,121.20
015	Seat adjuster top 60x40x3	Process: CNC Part Material: Aluminum Surface Finish: Anodising Surface Color: Satin Black Remarks:	22-25 Day(s)	5	€100.39	€501.95
			33-36 Day(s)	20	€82.13	€1,642.60
016	Threaded block for M4	Process: CNC Part Material: Aluminum Surface Finish: Anodising Surface Color: Satin Black Remarks:	22-25 Day(s)	20	€9.13	€182.60
			33-36 Day(s)	80	€5.74	€459.20
017	Aluminum reinforcment diamond	Process: CNC Part Material: Aluminum Surface Finish: Anodising Surface Color: Satin Black Remarks:	22-25 Day(s)	5	€226.85	€1,134.25
			33-36 Day(s)	20	€178.61	€3,572.20
018	Plastic seat diamond shape	Process: CNC Part Material: ABS- Surface Finish: Smooth+Painting Surface Color: Satin Dark Orange Remarks:	22-25 Day(s)	5	€286.19	€1,430.95
			33-36 Day(s)	20	€216.82	€4,336.40



Item #	Item Name	Description	Lead Time	Quantity	Unit Price	Amount
019	Assembly	Process: welding Part Material: Surface Finish: Surface Color: Remarks:	22-25 Day(s)	5	€534.53	€2,672.65
			33-36 Day(s)	20	€469.34	€9,386.80
					<b>PARTS Total:</b>	<b>TBD</b>
					<b>GRAND Total:</b>	<b>TBD</b>

Thank you for the opportunity to quote. Please contact us if you have any enquiries concerning this quote.

**Please sign and return this quotation by email to confirm your order.**

Date

Signature

I confirm that I am an authorized signatory of the client company.

## NOTES

### 1. Terms & Conditions

Acceptance of our quotation or placing of an order shall constitute acceptance of our terms & conditions:  
[www.starrapid.com/terms-and-conditions/](http://www.starrapid.com/terms-and-conditions/)

### 2. Import

All importers are legally required to provide a valid HS Code for the purposes of importation into your own country.

### 3. Payment

#### 3.1 General

- Prices exclude VAT. You may be required to pay VAT and Import Duties in your own Country.
- A 4% fee will be applied to orders that are paid via PayPal.

#### 3.2 Tooling

- Proforma Invoice upon receipt of Customer PO, tooling project starts after receiving 50% upfront payment.
- If no approval received within 30 days after 1st sample shipment, the balance 50% is treated as payment due.
- If delay is caused due to customer's fault (e.g. design change & etc), the customer shall pay 50% balance amount and we carry on the order upon receipt of the 50% balance.

### 4. Other

#### 4.1 General

- Special tolerance requirement should be provided before the order confirmation, otherwise our standard tolerances will apply.
- The buyer is fully responsible for the correctness of the supplied data files. Star Rapid is not responsible to check for consistency between the files. When 3D CAD and 2D drawings are supplied, the parts will be manufactured according to the 3D CAD files. The 2D drawings will be used for general information and tolerances only.

#### 4.2 RP - Star Prototype's General Tolerances (finer tolerances are based on best effort only!)

- CNC (Metals): DIN ISO 2768 fine | CNC (Plastics): DIN ISO 2768 medium
- Vacuum casting: between +/- 0.2mm or 0.15% (depend on part size)
- SLA: +/- 0.1mm < 100mm or +/- 0.2mm (100mm to 200mm)
- SLS: +/- 0.2mm < 100mm or +/- 0.3mm (100mm to 200mm)

#### 4.3 Tooling & Molding incl. ECN

- Tooling lead-time (T1) starts from Design for Manufacturing (DFM) confirmation.
- 5 pcs/sets of samples for tool approval plus shipment are included.
- Tool price includes first inspection report - supplied upon request only. (NO FULL ISIR)
- If no molding order received over 18 months since last order, the mold may be scrapped by STAR if no reply received within 1 month upon our enquiry about the disposal method of the mold.

---

#### Star Rapid Limited

Room 4, 11/F, Tern Plaza, 5 Cameron Road, Tsim Sha Tsui, Kowloon, Hong Kong

Tel.: +852 28494 555

Fax: +852 28494 556

Email: [enquiry@starrapid.com](mailto:enquiry@starrapid.com) | [www.starrapid.com](http://www.starrapid.com)

#### Bank Information

HSBC (The Hong Kong and Shanghai Banking Corporation Ltd.)

Address: 1 Queen's Road, Central, Hong Kong

Account Name: Star Rapid Limited

Account Number: 817-890171-838

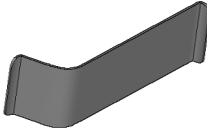
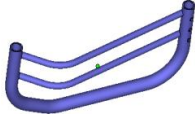
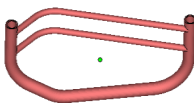
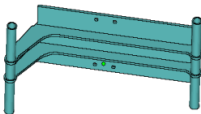
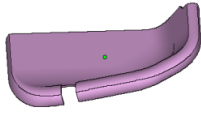
Swift Code: HSBCHKHKKH

Bank Code: 004817

## B.6 Seat Arm and Post

Client No.: SP18SA006  
 Client: Exero Technologies AS  
 Phone.: +47 905 13 537  
 Fax.:  
 Contact: Andre Haig Johnsen  
 Website: <http://www.exerotech.com>  
 E-mail: [andre@exerotech.com](mailto:andre@exerotech.com)

Provider: SUNPE LIMITED  
 Address: No.70 Tongxing Xi Rd, Dongsheng town,  
 Zhongshan city, GuangDong, 528415, P.R.China,  
 Tel.: +86 (0) 760 22825560,22825561,22825562,22825563  
 Fax.: +86 (0) 760 22211992  
 Contact: Daisy Zheng  
 Website: <http://www.sunpe.com>  
 E-mail: [RP\\_11@sunpe.com](mailto:RP_11@sunpe.com), [sunpe.rp011@gmail.com](mailto:sunpe.rp011@gmail.com)

1. Prototypes Cost					
Item No.	IGES/STEP/STL file name	Material	technics	Qty	Total cost
1	center_piece	ABS	CNC	1	EUR 120
		Size: Max X:120.000 mm Max Y:84.641 mm Max Z:315.915 mm  <b>Volume:106680 mm3</b>  Surface finish:Painting, Dark orange, Satin			
2	frame_left	Aluminum	Sheet Metal	1	EUR 373
		Size: Max X:154.326 mm Max Y:85.000 mm Max Z:310.000 mm  <b>Volume:104784 mm3</b>  Surface finish:Powder coating, Black, Satin			
3	frame_right	Aluminum	Sheet Metal	1	EUR 373
		Size: Max X:154.326 mm Max Y:85.000 mm Max Z:310.000 mm  <b>Volume:104790 mm3</b>  Surface finish:Powder coating, Black, Satin			
4	main_base	Aluminum	Sheet Metal	1	EUR 287
		Size: Max X:170.000 mm Max Y:94.999 mm Max Z:310.000 mm  <b>Volume:187628 mm3</b>  Surface finish:Powder coating, Black, Satin			
5	main_seat_left	ABS	CNC	1	EUR 131
		Size: Max X:156.838 mm Max Y:82.084 mm Max Z:316.200 mm  <b>Volume:144259 mm3</b>  Surface finish:Painting, Black, Satin			

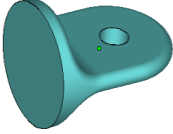
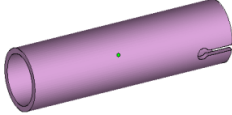
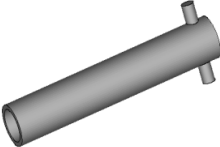
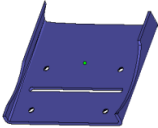
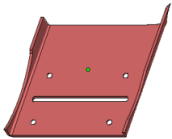
Client No.: SP18SA006  
 Client: Exero Technologies AS  
 Phone.: +47 905 13 537  
 Fax.:  
 Contact: Andre Haig Johnsen  
 Website: <http://www.exerotech.com>  
 E-mail: [andre@exerotech.com](mailto:andre@exerotech.com)

Provider: SUNPE LIMITED  
 Address: No.70 Tongxing Xi Rd, Dongsheng town,  
 Zhongshan city, GuangDong, 528415, P.R.China,  
 Tel.: +86 (0) 760 22825560,22825561,22825562,22825563  
 Fax.: +86 (0) 760 22211992  
 Contact: Daisy Zheng  
 Website: <http://www.sunpe.com>  
 E-mail: [RP\\_11@sunpe.com](mailto:RP_11@sunpe.com), [sunpe.rp011@gmail.com](mailto:sunpe.rp011@gmail.com)

Item No.	Part Name	Material	Process	Quantity	Price
6	main_seat_right	ABS	CNC	1	EUR 131
		<b>Size:</b> Max X:156.838 mm Max Y:82.084 mm Max Z:316.200 mm  <b>Volume:144264 mm3</b>  Surface finish:Painting, Black, Satin			
7	seat_arm_latch	Aluminum	Sheet Metal	1	EUR 85
		<b>Size:</b> Max X:31.427 mm Max Y:148.812 mm Max Z:46.000 mm  <b>Volume:14799 mm3</b>  Surface finish:Powder coating, Black, Satin			
8	seat_arm_lock_bracket	Aluminum	Sheet Metal	1	EUR 43
		<b>Size:</b> Max X:34.000 mm Max Y:50.000 mm Max Z:82.132 mm  <b>Volume:16046 mm3</b>  Surface finish:Powder coating, Black, Satin			Note: Weld to "sheet bracket head"
9	seat_arm_sheet_bracket_head	Aluminum	Sheet Metal	1	EUR 28
		<b>Size:</b> Max X:110.000 mm Max Y:41.438 mm Max Z:155.250 mm  <b>Volume:46446 mm3</b>  Surface finish:Powder coating, Black, Satin			Note:Weld to " sheet bracket and lock bracket"
10	seat_arm_sheet_bracket	Aluminum	Sheet Metal	1	EUR 87
		<b>Size:</b> Max X:70.000 mm Max Y:189.751 mm Max Z:376.446 mm  <b>Volume:128392 mm3</b>  Surface finish:Powder coating, Black, Satin			Note: Weld to "bracket head"

Client No.: SP18SA006  
 Client: Exero Technologies AS  
 Phone.: +47 905 13 537  
 Fax.:  
 Contact: Andre Haig Johnsen  
 Website: <http://www.exerotech.com>  
 E-mail: [andre@exerotech.com](mailto:andre@exerotech.com)

Provider: SUNPE LIMITED  
 Address: No.70 Tongxing Xi Rd, Dongsheng town,  
 Zhongshan city, GuangDong, 528415, P.R.China,  
 Tel.: +86 (0) 760 22825560,22825561,22825562,22825563  
 Fax.: +86 (0) 760 22211992  
 Contact: Daisy Zheng  
 Website: <http://www.sunpe.com>  
 E-mail: [RP\\_11@sunpe.com](mailto:RP_11@sunpe.com), [sunpe.rp011@gmail.com](mailto:sunpe.rp011@gmail.com)

Item No.	Part Name	Material	Process	Quantity	Price
11	bracket_post	Aluminum	CNC	1	EUR 22
		<b>Size:</b> Max X:40.000 mm Max Y:50.992 mm Max Z:40.000 mm  <b>Volume:17896 mm3</b>  Surface finish:Powder coating, Black, Satin		Note:Weld to "Tube big"	
12	tube_big	Aluminum	CNC&Lathe	1	EUR 89
		<b>Size:</b> Max X:40.000 mm Max Y:152.000 mm Max Z:40.000 mm  <b>Volume:60585 mm3</b>  Surface finish:Powder coating, Black, Satin			
13	tube_smal	Aluminum	CNC&Lathe	1	EUR 89
		<b>Size:</b> Max X:32.000 mm Max Y:175.000 mm Max Z:60.000 mm  <b>Volume:58924 mm3</b>  Surface finish:Powder coating, Black, Satin			
14	slider_front_bracket_left	Aluminum	Sheet Metal	1	EUR 135
		<b>Size:</b> Max X:142.112 mm Max Y:38.689 mm Max Z:160.982 mm  <b>Volume:52654 mm3</b>  Surface finish:Powder coating, Black, Satin		Note:Weld to "slider frame"	
15	slider_front_bracket_right	Aluminum	Sheet Metal	1	EUR 135
		<b>Size:</b> Max X:142.112 mm Max Y:38.689 mm Max Z:160.982 mm  <b>Volume:52568 mm3</b>  Surface finish:Powder coating, Black, Satin		Note:Weld to "slider frame"	

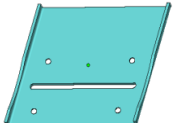
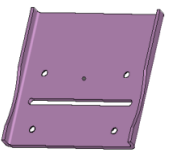
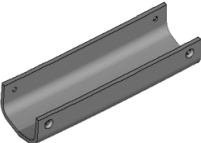
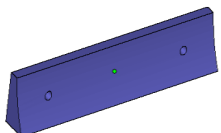
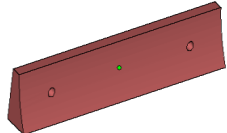


# Prototypes Quotation

Quotation No.:SP18SA006-20180327A

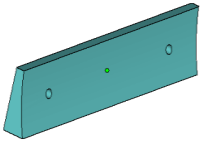
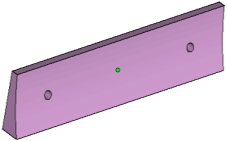
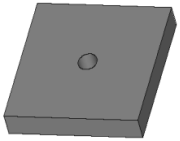
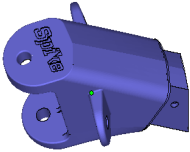
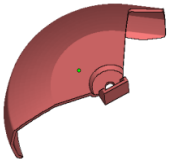
Client No.: SP18SA006  
 Client: Exero Technologies AS  
 Phone.: +47 905 13 537  
 Fax.:  
 Contact: Andre Haig Johnsen  
 Website: <http://www.exerotech.com>  
 E-mail: [andre@exerotech.com](mailto:andre@exerotech.com)

Provider: SUNPE LIMITED  
 Address: No.70 Tongxing Xi Rd, Dongsheng town,  
 Zhongshan city, GuangDong, 528415, P.R.China,  
 Tel.: +86 (0) 760 22825560,22825561,22825562,22825563  
 Fax.: +86 (0) 760 22211992  
 Contact: Daisy Zheng  
 Website: <http://www.sunpe.com>  
 E-mail: [RP\\_11@sunpe.com](mailto:RP_11@sunpe.com), [sunpe.rp011@gmail.com](mailto:sunpe.rp011@gmail.com)

Item No.	Part Name	Material	Process	Quantity	Price
16	slider_rear_bracket_left	Aluminum	Sheet Metal	1	EUR 135
		<b>Size:</b> Max X:121.321 mm Max Y:18.064 mm Max Z:159.259 mm  <b>Volume:50949 mm3</b>  Surface finish:Powder coating, Black, Satin		Note:Weld to "slider frame"	
17	slider_rear_bracket_right	Aluminum	Sheet Metal	1	EUR 135
		<b>Size:</b> Max X:121.321 mm Max Y:18.064 mm Max Z:159.259 mm  <b>Volume:51020 mm3</b>  Surface finish:Powder coating, Black, Satin		Note:Weld to "slider frame"	
18	slider_frame	Aluminum	Sheet Metal	2	EUR 269
		<b>Size:</b> Max X:58.400 mm Max Y:69.753 mm Max Z:192.395 mm  <b>Volume:81801 mm3</b>  Surface finish:Powder coating, Black, Satin			
19	support_guide_1	ABS	CNC	2	EUR 92
		<b>Size:</b> Max X:29.000 mm Max Y:132.959 mm Max Z:12.349 mm  <b>Volume:28353 mm3</b>  Surface finish:Painting, Dark orange, Satin			
20	support_guide_2	ABS	CNC	2	EUR 92
		<b>Size:</b> Max X:29.000 mm Max Y:132.959 mm Max Z:12.349 mm  <b>Volume:28353 mm3</b>  Surface finish:Painting, Dark orange, Satin			

Client No.: SP18SA006  
 Client: Exero Technologies AS  
 Phone.: +47 905 13 537  
 Fax.:  
 Contact: Andre Haig Johnsen  
 Website: <http://www.exerotech.com>  
 E-mail: [andre@exerotech.com](mailto:andre@exerotech.com)

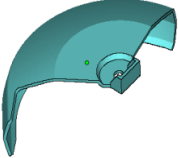
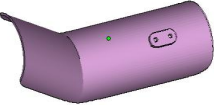
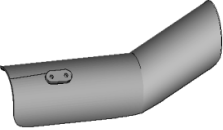

Provider: SUNPE LIMITED  
 Address: No.70 Tongxing Xi Rd, Dongsheng town,  
 Zhongshan city, GuangDong, 528415, P.R.China.  
 Tel.: +86 (0) 760 22825560,22825561,22825562,22825563  
 Fax.: +86 (0) 760 22211992  
 Contact: Daisy Zheng  
 Website: <http://www.sunpe.com>  
 E-mail: [RP\\_11@sunpe.com](mailto:RP_11@sunpe.com), [sunpe.rp011@gmail.com](mailto:sunpe.rp011@gmail.com)

Item No.	Part Name	Material	Process	Quantity	Price
21	support_guide_2	ABS	CNC	2	EUR 92
		<b>Size:</b> Max X:29.000 mm Max Y:132.959 mm Max Z:12.349 mm  <b>Volume:28353 mm3</b>  Surface finish:Painting, Dark orange, Satin			
22	support_guide_4	ABS	CNC	2	EUR 92
		<b>Size:</b> Max X:29.000 mm Max Y:132.959 mm Max Z:12.349 mm  <b>Volume:28353 mm3</b>  Surface finish:Painting, Dark orange, Satin			
23	t-lock_bit	Stainless Steel	CNC	8	EUR 98
		<b>Size:</b> Max X:18.000 mm Max Y:4.000 mm Max Z:18.000 mm  <b>Volume:995 mm3</b>  Surface finish:Powder coating, Black, Satin			
24	profile_end	Aluminum	CNC/Laser/EDM	2	EUR 460
		<b>Size:</b> Max X:110.000 mm Max Y:89.414 mm Max Z:155.210 mm  <b>Volume:161546 mm3</b>  Surface finish:Powder coating, Black, Logo can be coated Satin, Dark orange			
25	mud_guard_right	ABS	CNC	1	EUR 153
		Silicone	Rapid Mould	1	EUR 207
		PU 8150	Vacuum Casting	2	EUR 77
		<b>Size:</b> Max X:77.199 mm Max Y:129.416 mm Max Z:192.933 mm  <b>Volume:79014 mm3</b>  Surface finish:Black, Satin			



Client No.: SP18SA006  
 Client: [Exero Technologies AS](http://www.exerotech.com)  
 Phone.: +47 905 13 537  
 Fax.:  
 Contact: [Andre Haig Johnsen](mailto:andre@exerotech.com)  
 Website: <http://www.exerotech.com>  
 E-mail: [andre@exerotech.com](mailto:andre@exerotech.com)

Provider: SUNPE LIMITED  
 Address: No.70 Tongxing Xi Rd, Dongsheng town, Zhongshan city, GuangDong, 528415, P.R.China,  
 Tel.: +86 (0) 760 22825560,22825561,22825562,22825563  
 Fax.: +86 (0) 760 22211992  
 Contact: Daisy Zheng  
 Website: <http://www.sunpe.com>  
 E-mail: [RP\\_11@sunpe.com](mailto:RP_11@sunpe.com), [sunpe.rp011@gmail.com](mailto:sunpe.rp011@gmail.com)

26	mud_guard_left	ABS	CNC	1	EUR 153
		Silicone	Rapid Mould	1	EUR 207
		PU 8150	Vacuum Casting	2	EUR 77
		<p><b>Size:</b>            Max X:77.199 mm            Max Y:129.416 mm            Max Z:192.933 mm</p> <p><b>Volume:79015 mm3</b></p> <p>Surface finish:Black, Satin</p>			
27	calf_support_left	ABS	CNC	1	EUR 230
		Silicone	Rapid Mould	1	EUR 433
		PU 8150	Vacuum Casting	1	EUR 60
		<p><b>Size:</b>            Max X:132.364 mm            Max Y:122.169 mm            Max Z:350.000 mm</p> <p><b>Volume:164189 mm3</b></p> <p>Surface finish:Black, Satin</p>			
28	calf_support_right	ABS	CNC	1	EUR 230
		Silicone	Rapid Mould	1	EUR 433
		PU 8150	Vacuum Casting	1	EUR 60
		<p><b>Size:</b>            Max X:132.370 mm            Max Y:122.169 mm            Max Z:350.000 mm</p> <p><b>Volume:164193 mm3</b></p> <p>Surface finish:Black, Satin</p>			
29	knee_support	ABS	CNC	1	EUR 146
		Silicone	Rapid Mould	1	EUR 207
		PU 8150	Vacuum Casting	2	EUR 88
		<p><b>Size:</b>            Max X:149.970 mm            Max Y:79.000 mm            Max Z:200.000 mm</p> <p><b>Volume:131602 mm3</b></p> <p>Surface finish:Black, Satin</p>			

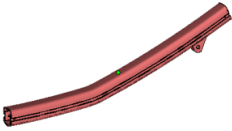
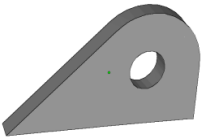


# Prototypes Quotation

Quotation No.:SP18SA006-20180327A

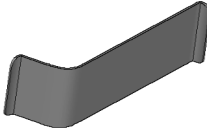
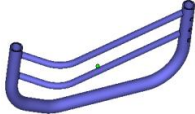
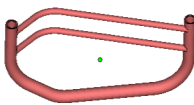
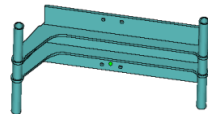
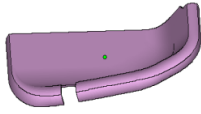
Client No.: SP18SA006  
 Client: Exero Technologies AS  
 Phone.: +47 905 13 537  
 Fax.:  
 Contact: Andre Haig Johnsen  
 Website: <http://www.exerotech.com>  
 E-mail: [andre@exerotech.com](mailto:andre@exerotech.com)

Provider: SUNPE LIMITED  
 Address: No.70 Tongxing Xi Rd, Dongsheng town,  
 Zhongshan city, GuangDong, 528415, P.R.China.  
 Tel.: +86 (0) 760 22825560,22825561,22825562,22825563  
 Fax.: +86 (0) 760 22211992  
 Contact: Daisy Zheng  
 Website: <http://www.sunpe.com>  
 E-mail: [RP\\_11@sunpe.com](mailto:RP_11@sunpe.com), [sunpe.rp011@gmail.com](mailto:sunpe.rp011@gmail.com)

30	main_profile	Steel	Mould	1	EUR 600
		AL6063	Extrusion	1	EUR 27
		AL6063	Sheet Metal	1	EUR 0
 <p><b>Size:</b>          Max X:50.000 mm          Max Y:105.060 mm          Max Z:771.588 mm</p> <p><b>Volume:515034 mm3</b></p> <p>Surface finish:Powder coating, Black, Satin</p>		<p><b>Note: Only provide straight extrusion and weld, bend is not included</b></p>			
31	shell_2_of_main_profile	AL6063	Sheet Metal	2	EUR 12
 <p><b>Size:</b>          Max X:5.000 mm          Max Y:35.141 mm          Max Z:52.945 mm</p> <p><b>Volume:4634 mm3</b></p> <p>Surface finish:Powder coating, Black, Satin</p>					
<b>Total Prototyping Cost:</b>					<b>EUR 6,993</b>
<b>2. Logistic Fee (Delivered by DHL Express Airway)</b>					
Item No.	IGES/STEP/STL file name	Gross volume	Destination	Qty	Total volume
1~31	Item 1 to item 31		Norway	1 set	55kg
				Sum:	55kg
				<b>Estimated Freight:</b>	<b>EUR 273</b>
DHL: Light weight cargo's freight based on package's gross volume.					
<b>3. Time</b>					
	Prototypes+After treatment+Painting (working days)	<b>DHL collect parcel (working days)</b>	Delivery to destination (working days)	Total (working days)	
	15	1	2	<b>18</b>	
<b>4.Summary</b>					
	Prototypes+After treatment+Painting	<b>DHL Freight</b>	Total Expense	Total period	
	EUR 6,993	EUR 273	<b>EUR 7,266</b>	<b>18</b>	
<b>5. Others</b>					
5.1.	<b>Knowledge property right</b>	Service provider should protect the knowledge property right of client, and keep secret for client.			
5.2.	<b>Customs duty and other local tax in destination country</b>	Client pay customs duty and other local tax in destination country, if happened.			
5.3.	<b>Period of validity for quotation</b>	One calendar month after quotation issued.			

Client No.: SP18SA006  
 Client: Exero Technologies AS  
 Phone.: +47 905 13 537  
 Fax.:  
 Contact: Andre Haig Johnsen  
 Website: <http://www.exerotech.com>  
 E-mail: [andre@exerotech.com](mailto:andre@exerotech.com)

Provider: SUNPE LIMITED  
 Address: No.70 Tongxing Xi Rd, Dongsheng town,  
 Zhongshan city, Guangdong, 528415, P.R.China,  
 Tel.: +86 (0) 760 22825560,22825561,22825562,22825563  
 Fax.: +86 (0) 760 22211992  
 Contact: Daisy Zheng  
 Website: <http://www.sunpe.com>  
 E-mail: [RP\\_11@sunpe.com](mailto:RP_11@sunpe.com), [sunpe.rp011@gmail.com](mailto:sunpe.rp011@gmail.com)

1. Prototypes Cost					
Item No.	IGES/STEP/STL file name	Material	technics	Qty	Total cost
1	center_piece	ABS	CNC	5	EUR 577
		Size: Max X:120.000 mm Max Y:84.641 mm Max Z:315.915 mm  <b>Volume:106680 mm3</b>  Surface finish:Painting, Dark orange, Satin			
2	frame_left	Aluminum	Sheet Metal	5	EUR 1,040
		Size: Max X:154.326 mm Max Y:85.000 mm Max Z:310.000 mm  <b>Volume:104784 mm3</b>  Surface finish:Powder coating, Black, Satin			
3	frame_right	Aluminum	Sheet Metal	5	EUR 1,040
		Size: Max X:154.326 mm Max Y:85.000 mm Max Z:310.000 mm  <b>Volume:104790 mm3</b>  Surface finish:Powder coating, Black, Satin			
4	main_base	Aluminum	Sheet Metal	5	EUR 920
		Size: Max X:170.000 mm Max Y:94.999 mm Max Z:310.000 mm  <b>Volume:187628 mm3</b>  Surface finish:Powder coating, Black, Satin			
5	main_seat_left	ABS	CNC	5	EUR 613
		Size: Max X:156.838 mm Max Y:82.084 mm Max Z:316.200 mm  <b>Volume:144259 mm3</b>  Surface finish:Painting, Black, Satin			

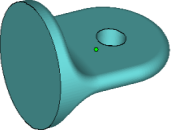
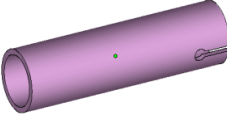
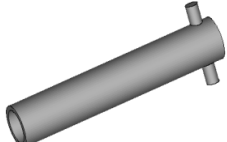
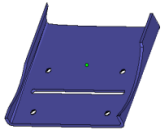
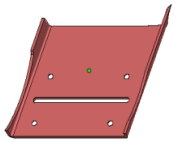
Client No.: SP18SA006  
 Client: Exero Technologies AS  
 Phone.: +47 905 13 537  
 Fax.:  
 Contact: Andre Haig Johnsen  
 Website: <http://www.exerotech.com>  
 E-mail: [andre@exerotech.com](mailto:andre@exerotech.com)

Provider: SUNPE LIMITED  
 Address: No.70 Tongxing Xi Rd, Dongsheng town,  
 Zhongshan city, GuangDong, 528415, P.R.China,  
 Tel.: +86 (0) 760 22825560,22825561,22825562,22825563  
 Fax.: +86 (0) 760 22211992  
 Contact: Daisy Zheng  
 Website: <http://www.sunpe.com>  
 E-mail: [RP\\_11@sunpe.com](mailto:RP_11@sunpe.com), [sunpe.rp011@gmail.com](mailto:sunpe.rp011@gmail.com)

Item No.	Part Name	Material	Process	Quantity	Price
6	main_seat_right	ABS	CNC	5	EUR 613
		<p><b>Size:</b>            Max X:156.838 mm            Max Y:82.084 mm            Max Z:316.200 mm</p> <p><b>Volume:144264 mm3</b></p> <p>Surface finish:Painting, Black, Satin</p>			
7	seat_arm_latch	Aluminum	Sheet Metal	5	EUR 270
		<p><b>Size:</b>            Max X:31.427 mm            Max Y:148.812 mm            Max Z:46.000 mm</p> <p><b>Volume:14799 mm3</b></p> <p>Surface finish:Powder coating, Black, Satin</p>			
8	seat_arm_lock_bracket	Aluminum	Sheet Metal	5	EUR 153
		<p><b>Size:</b>            Max X:34.000 mm            Max Y:50.000 mm            Max Z:82.132 mm</p> <p><b>Volume:16046 mm3</b></p> <p>Surface finish:Powder coating, Black, Satin</p> <p>Note: Weld to "sheet bracket head"</p>			
9	seat_arm_sheet_bracket_head	Aluminum	Sheet Metal	5	EUR 93
		<p><b>Size:</b>            Max X:110.000 mm            Max Y:41.438 mm            Max Z:155.250 mm</p> <p><b>Volume:46446 mm3</b></p> <p>Surface finish:Powder coating, Black, Satin</p> <p>Note:Weld to "sheet bracket and lock bracket"</p>			
10	seat_arm_sheet_bracket	Aluminum	Sheet Metal	5	EUR 270
		<p><b>Size:</b>            Max X:70.000 mm            Max Y:189.751 mm            Max Z:376.446 mm</p> <p><b>Volume:128392 mm3</b></p> <p>Surface finish:Powder coating, Black, Satin</p> <p>Note: Weld to "bracket head"</p>			

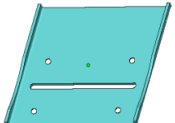
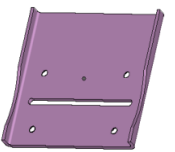
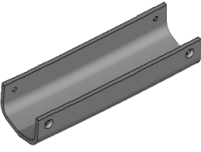
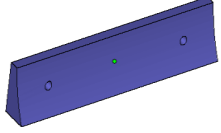
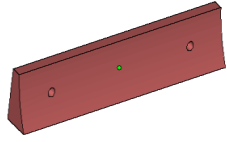
Client No.: SP18SA006  
 Client: Exero Technologies AS  
 Phone.: +47 905 13 537  
 Fax.:  
 Contact: Andre Haig Johnsen  
 Website: <http://www.exerotech.com>  
 E-mail: [andre@exerotech.com](mailto:andre@exerotech.com)

Provider: SUNPE LIMITED  
 Address: No.70 Tongxing Xi Rd, Dongsheng town,  
 Zhongshan city, GuangDong, 528415, P.R.China,  
 Tel.: +86 (0) 760 22825560,22825561,22825562,22825563  
 Fax.: +86 (0) 760 22211992  
 Contact: Daisy Zheng  
 Website: <http://www.sunpe.com>  
 E-mail: [RP\\_11@sunpe.com](mailto:RP_11@sunpe.com), [sunpe.rp011@gmail.com](mailto:sunpe.rp011@gmail.com)

Item No.	Part Name	Material	Process	Quantity	Price
11	bracket_post	Aluminum	CNC	5	EUR 107
		<b>Size:</b> Max X:40.000 mm Max Y:50.992 mm Max Z:40.000 mm  <b>Volume:17896 mm3</b>  Surface finish:Powder coating, Black, Satin		Note:Weld to "Tube big"	
12	tube_big	Aluminum	Sheet Metal	5	EUR 270
		<b>Size:</b> Max X:40.000 mm Max Y:152.000 mm Max Z:40.000 mm  <b>Volume:60585 mm3</b>  Surface finish:Powder coating, Black, Satin			
13	tube_smal	Aluminum	Sheet Metal	5	EUR 270
		<b>Size:</b> Max X:32.000 mm Max Y:175.000 mm Max Z:60.000 mm  <b>Volume:58924 mm3</b>  Surface finish:Powder coating, Black, Satin			
14	slider_front_bracket_left	Aluminum	Sheet Metal	5	EUR 387
		<b>Size:</b> Max X:142.112 mm Max Y:38.689 mm Max Z:160.982 mm  <b>Volume:52654 mm3</b>  Surface finish:Powder coating, Black, Satin		Note:Weld to "slider frame"	
15	slider_front_bracket_right	Aluminum	Sheet Metal	5	EUR 387
		<b>Size:</b> Max X:142.112 mm Max Y:38.689 mm Max Z:160.982 mm  <b>Volume:52568 mm3</b>  Surface finish:Powder coating, Black, Satin		Note:Weld to "slider frame"	

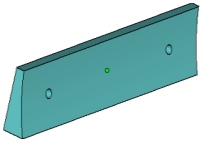
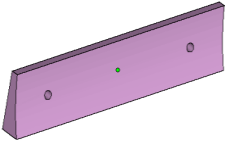
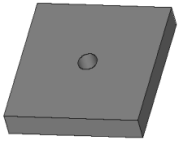
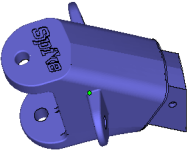
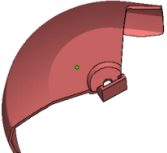
Client No.: SP18SA006  
 Client: Exero Technologies AS  
 Phone.: +47 905 13 537  
 Fax.:  
 Contact: Andre Haig Johnsen  
 Website: <http://www.exerotech.com>  
 E-mail: [andre@exerotech.com](mailto:andre@exerotech.com)

Provider: SUNPE LIMITED  
 Address: No.70 Tongxing Xi Rd, Dongsheng town,  
 Zhongshan city, GuangDong, 528415, P.R.China,  
 Tel.: +86 (0) 760 22825560,22825561,22825562,22825563  
 Fax.: +86 (0) 760 22211992  
 Contact: Daisy Zheng  
 Website: <http://www.sunpe.com>  
 E-mail: [RP\\_11@sunpe.com](mailto:RP_11@sunpe.com), [sunpe.rp011@gmail.com](mailto:sunpe.rp011@gmail.com)

Item No.	Part Name	Material	Process	Quantity	Price
16	slider_rear_bracket_left	Aluminum	Sheet Metal	5	EUR 387
		<b>Size:</b> Max X:121.321 mm Max Y:18.064 mm Max Z:159.259 mm  <b>Volume:50949 mm3</b>  Surface finish:Powder coating, Black, Satin		Note:Weld to "slider frame"	
17	slider_rear_bracket_right	Aluminum	Sheet Metal	5	EUR 387
		<b>Size:</b> Max X:121.321 mm Max Y:18.064 mm Max Z:159.259 mm  <b>Volume:51020 mm3</b>  Surface finish:Powder coating, Black, Satin		Note:Weld to "slider frame"	
18	slider_frame	Aluminum	Sheet Metal	10	EUR 1,040
		<b>Size:</b> Max X:58.400 mm Max Y:69.753 mm Max Z:192.395 mm  <b>Volume:81801 mm3</b>  Surface finish:Powder coating, Black, Satin			
19	support_guide_1	ABS	CNC	10	EUR 293
		<b>Size:</b> Max X:29.000 mm Max Y:132.959 mm Max Z:12.349 mm  <b>Volume:28353 mm3</b>  Surface finish:Painting, Dark orange, Satin			
20	support_guide_2	ABS	CNC	10	EUR 293
		<b>Size:</b> Max X:29.000 mm Max Y:132.959 mm Max Z:12.349 mm  <b>Volume:28353 mm3</b>  Surface finish:Painting, Dark orange, Satin			

Client No.: SP18SA006  
 Client: Exero Technologies AS  
 Phone.: +47 905 13 537  
 Fax.:  
 Contact: Andre Haig Johnsen  
 Website: <http://www.exerotech.com>  
 E-mail: [andre@exerotech.com](mailto:andre@exerotech.com)

Provider: SUNPE LIMITED  
 Address: No.70 Tongxing Xi Rd, Dongsheng town,  
 Zhongshan city, GuangDong, 528415, P.R.China.  
 Tel.: +86 (0) 760 22825560,22825561,22825562,22825563  
 Fax.: +86 (0) 760 22211992  
 Contact: Daisy Zheng  
 Website: <http://www.sunpe.com>  
 E-mail: [RP\\_11@sunpe.com](mailto:RP_11@sunpe.com), [sunpe.rp011@gmail.com](mailto:sunpe.rp011@gmail.com)

Item No.	Part Name	Material	Process	Quantity	Price
21	support_guide_2	ABS	CNC	10	EUR 293
		<b>Size:</b> Max X:29.000 mm Max Y:132.959 mm Max Z:12.349 mm  <b>Volume:28353 mm3</b>  Surface finish:Painting, Dark orange, Satin			
22	support_guide_4	ABS	CNC	10	EUR 293
		<b>Size:</b> Max X:29.000 mm Max Y:132.959 mm Max Z:12.349 mm  <b>Volume:28353 mm3</b>  Surface finish:Painting, Dark orange, Satin			
23	t-lock_bit	Stainless Steel	CNC	40	EUR 309
		<b>Size:</b> Max X:18.000 mm Max Y:4.000 mm Max Z:18.000 mm  <b>Volume:995 mm3</b>  Surface finish:Powder coating, Black, Satin			
24	profile_end	Aluminum	CNC/Laser/EDM	10	EUR 1,687
		<b>Size:</b> Max X:110.000 mm Max Y:89.414 mm Max Z:155.210 mm  <b>Volume:161546 mm3</b>  Surface finish:Powder coating, Black, Logo can be coated Satin, Dark orange			
25	mud_guard_right	ABS	CNC	1	EUR 153
		Silicone	Rapid Mould	1	EUR 39
		PU 8150	Vacuum Casting	10	EUR 307
		<b>Size:</b> Max X:77.199 mm Max Y:129.416 mm Max Z:192.933 mm  <b>Volume:79014 mm3</b>  Surface finish:Black, Satin			

Client No.: SP18SA006  
 Client: [Exero Technologies AS](http://www.exerotech.com)  
 Phone.: +47 905 13 537  
 Fax.:  
 Contact: [Andre Haig Johnsen](mailto:andre@exerotech.com)  
 Website: <http://www.exerotech.com>  
 E-mail: [andre@exerotech.com](mailto:andre@exerotech.com)

Provider: SUNPE LIMITED  
 Address: No.70 Tongxing Xi Rd, Dongsheng town,  
 Zhongshan city, GuangDong, 528415, P.R.China,  
 Tel.: +86 (0) 760 22825560,22825561,22825562,22825563  
 Fax.: +86 (0) 760 22211992  
 Contact: Daisy Zheng  
 Website: <http://www.sunpe.com>  
 E-mail: [RP\\_11@sunpe.com](mailto:RP_11@sunpe.com), [sunpe.rp011@gmail.com](mailto:sunpe.rp011@gmail.com)

Item No.	Part Name	Material	Process	Quantity	Price
		ABS	CNC	1	EUR 153
26	mud_guard_left	Silicone	Rapid Mould	1	EUR 39
		PU 8150	Vacuum Casting	10	EUR 307
		 <p><b>Size:</b>            Max X:77.199 mm            Max Y:129.416 mm            Max Z:192.933 mm</p> <p><b>Volume:79015 mm3</b></p> <p>Surface finish:Black, Satin</p>			
27	calf_support_left	ABS	CNC	1	EUR 230
		Silicone	Rapid Mould	1	EUR 433
		PU 8150	Vacuum Casting	5	EUR 230
 <p><b>Size:</b>            Max X:132.364 mm            Max Y:122.169 mm            Max Z:350.000 mm</p> <p><b>Volume:164189 mm3</b></p> <p>Surface finish:Black, Satin</p>					
28	calf_support_right	ABS	CNC	1	EUR 230
		Silicone	Rapid Mould	1	EUR 433
		PU 8150	Vacuum Casting	5	EUR 230
 <p><b>Size:</b>            Max X:132.370 mm            Max Y:122.169 mm            Max Z:350.000 mm</p> <p><b>Volume:164193 mm3</b></p> <p>Surface finish:Black, Satin</p>					
29	knee_support	ABS	CNC	1	EUR 146
		Silicone	Rapid Mould	1	EUR 207
		PU 8150	Vacuum Casting	10	EUR 307
 <p><b>Size:</b>            Max X:149.970 mm            Max Y:79.000 mm            Max Z:200.000 mm</p> <p><b>Volume:131602 mm3</b></p> <p>Surface finish:Black, Satin</p>					



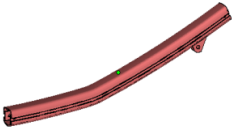
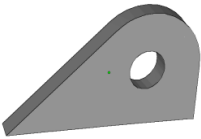


# Prototypes Quotation

Quotation No.:SP18SA006-20180327B

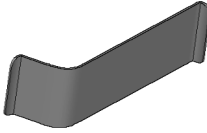
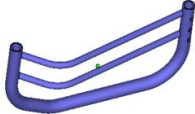
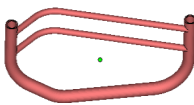
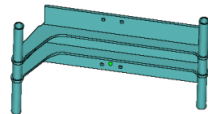
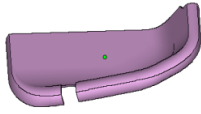
Client No.: SP18SA006  
 Client: Exero Technologies AS  
 Phone.: +47 905 13 537  
 Fax.:  
 Contact: Andre Haig Johnsen  
 Website: <http://www.exerotech.com>  
 E-mail: [andre@exerotech.com](mailto:andre@exerotech.com)

Provider: SUNPE LIMITED  
 Address: No.70 Tongxing Xi Rd, Dongsheng town,  
 Zhongshan city, GuangDong, 528415, P.R.China.  
 Tel.: +86 (0) 760 22825560,22825561,22825562,22825563  
 Fax.: +86 (0) 760 22211992  
 Contact: Daisy Zheng  
 Website: <http://www.sunpe.com>  
 E-mail: [RP\\_11@sunpe.com](mailto:RP_11@sunpe.com), [sunpe.rp011@gmail.com](mailto:sunpe.rp011@gmail.com)

30	main_profile	Steel	Mould	1	EUR 600
		AL6063	Extrusion	5	EUR 107
		AL6063	Sheet Metal	5	EUR 0
 <p><b>Size:</b>          Max X:50.000 mm          Max Y:105.060 mm          Max Z:771.588 mm</p> <p><b>Volume:515034 mm3</b></p> <p>Surface finish:Powder coating, Black, Satin</p>		<p>Note: Only provide straight extrusion and weld, bend is not included</p>			
31	shell_2_of_main_profile	AL6063	Sheet Metal	10	EUR 53
 <p><b>Size:</b>          Max X:5.000 mm          Max Y:35.141 mm          Max Z:52.945 mm</p> <p><b>Volume:4634 mm3</b></p> <p>Surface finish:Powder coating, Black, Satin</p>					
<b>Total Prototyping Cost:</b>					<b>EUR 16,196</b>
<b>2. Logistic Fee (Delivered by DHL Express Airway)</b>					
Item No.	IGES/STEP/STL file name	Gross volume	Destination	Qty	Total volume
1~31	Item 1 to item 31		Norway	5 sets	180kg
				Sum:	180kg
				<b>Estimated Freight:</b>	<b>EUR 1,008</b>
DHL: Light weight cargo's freight based on package's gross volume.					
<b>3. Time</b>					
	Prototypes+After treatment+Painting (working days)	DHL collect parcel (working days)	Delivery to destination (working days)	Total (working days)	
	15	1	2	<b>18</b>	
<b>4.Summary</b>					
	Prototypes+After treatment+Painting	DHL Freight	Total Expense	Total period	
	EUR 16,196	EUR 1,008	<b>EUR 17,204</b>	<b>18</b>	
<b>5. Others</b>					
5.1.	<b>Knowledge property right</b>	Service provider should protect the knowledge property right of client, and keep secret for client.			
5.2.	<b>Customs duty and other local tax in destination country</b>	Client pay customs duty and other local tax in destination country, if happened.			
5.3.	<b>Period of validity for quotation</b>	One calendar month after quotation issued.			

Client No.: SP18SA006  
 Client: Exero Technologies AS  
 Phone.: +47 905 13 537  
 Fax.:  
 Contact: Andre Haig Johnsen  
 Website: <http://www.exerotech.com>  
 E-mail: [andre@exerotech.com](mailto:andre@exerotech.com)

Provider: SUNPE LIMITED  
 Address: No.70 Tongxing Xi Rd, Dongsheng town,  
 Zhongshan city, GuangDong, 528415, P.R.China,  
 Tel.: +86 (0) 760 22825560,22825561,22825562,22825563  
 Fax.: +86 (0) 760 22211992  
 Contact: Daisy Zheng  
 Website: <http://www.sunpe.com>  
 E-mail: [RP\\_11@sunpe.com](mailto:RP_11@sunpe.com), [sunpe.rp011@gmail.com](mailto:sunpe.rp011@gmail.com)

1. Prototypes Cost					
Item No.	IGES/STEP/STL file name	Material	technics	Qty	Total cost
1	center_piece	ABS	CNC	15	EUR 1,600
		Size: Max X:120.000 mm Max Y:84.641 mm Max Z:315.915 mm  <b>Volume:106680 mm3</b>  Surface finish:Painting, Dark orange, Satin			
2	frame_left	Aluminum	Sheet Metal	15	EUR 2,300
		Size: Max X:154.326 mm Max Y:85.000 mm Max Z:310.000 mm  <b>Volume:104784 mm3</b>  Surface finish:Powder coating, Black, Satin			
3	frame_right	Aluminum	Sheet Metal	15	EUR 2,300
		Size: Max X:154.326 mm Max Y:85.000 mm Max Z:310.000 mm  <b>Volume:104790 mm3</b>  Surface finish:Powder coating, Black, Satin			
4	main_base	Aluminum	Sheet Metal	15	EUR 1,730
		Size: Max X:170.000 mm Max Y:94.999 mm Max Z:310.000 mm  <b>Volume:187628 mm3</b>  Surface finish:Powder coating, Black, Satin			
5	main_seat_left	ABS	CNC	15	EUR 1,720
		Size: Max X:156.838 mm Max Y:82.084 mm Max Z:316.200 mm  <b>Volume:144259 mm3</b>  Surface finish:Painting, Black, Satin			



# Prototypes Quotation

Quotation No.:SP18SA006-20180327C

Client No.: SP18SA006  
 Client: Exero Technologies AS  
 Phone.: +47 905 13 537  
 Fax.:  
 Contact: Andre Haig Johnsen  
 Website: <http://www.exerotech.com>  
 E-mail: [andre@exerotech.com](mailto:andre@exerotech.com)

Provider: SUNPE LIMITED  
 Address: No.70 Tongxing Xi Rd, Dongsheng town,  
 Zhongshan city, GuangDong, 528415, P.R.China,  
 Tel.: +86 (0) 760 22825560,22825561,22825562,22825563  
 Fax.: +86 (0) 760 22211992  
 Contact: Daisy Zheng  
 Website: <http://www.sunpe.com>  
 E-mail: [RP\\_11@sunpe.com](mailto:RP_11@sunpe.com), [sunpe.rp011@gmail.com](mailto:sunpe.rp011@gmail.com)

Item No.	Part Name	Material	Process	Quantity	Price
6	main_seat_right	ABS	CNC	15	EUR 1,720
		<p><b>Size:</b>            Max X:156.838 mm            Max Y:82.084 mm            Max Z:316.200 mm</p> <p><b>Volume:144264 mm3</b></p> <p>Surface finish:Painting, Black, Satin</p>			
7	seat_arm_latch	Aluminum	Sheet Metal	15	EUR 460
		<p><b>Size:</b>            Max X:31.427 mm            Max Y:148.812 mm            Max Z:46.000 mm</p> <p><b>Volume:14799 mm3</b></p> <p>Surface finish:Powder coating, Black, Satin</p>			
8	seat_arm_lock_bracket	Aluminum	Sheet Metal	15	EUR 570
		<p><b>Size:</b>            Max X:34.000 mm            Max Y:50.000 mm            Max Z:82.132 mm</p> <p><b>Volume:16046 mm3</b></p> <p>Surface finish:Powder coating, Black, Satin</p> <p>Note: Weld to "sheet bracket head"</p>			
9	seat_arm_sheet_bracket_head	Aluminum	Sheet Metal	15	EUR 210
		<p><b>Size:</b>            Max X:110.000 mm            Max Y:41.438 mm            Max Z:155.250 mm</p> <p><b>Volume:46446 mm3</b></p> <p>Surface finish:Powder coating, Black, Satin</p> <p>Note:Weld to "sheet bracket and lock bracket"</p>			
10	seat_arm_sheet_bracket	Aluminum	Sheet Metal	15	EUR 580
		<p><b>Size:</b>            Max X:70.000 mm            Max Y:189.751 mm            Max Z:376.446 mm</p> <p><b>Volume:128392 mm3</b></p> <p>Surface finish:Powder coating, Black, Satin</p> <p>Note: Weld to "bracket head"</p>			

Client No.: SP18SA006  
 Client: Exero Technologies AS  
 Phone.: +47 905 13 537  
 Fax.:  
 Contact: Andre Haig Johnsen  
 Website: <http://www.exerotech.com>  
 E-mail: [andre@exerotech.com](mailto:andre@exerotech.com)

Provider: SUNPE LIMITED  
 Address: No.70 Tongxing Xi Rd, Dongsheng town,  
 Zhongshan city, GuangDong, 528415, P.R.China,  
 Tel.: +86 (0) 760 22825560,22825561,22825562,22825563  
 Fax.: +86 (0) 760 22211992  
 Contact: Daisy Zheng  
 Website: <http://www.sunpe.com>  
 E-mail: [RP\\_11@sunpe.com](mailto:RP_11@sunpe.com), [sunpe.rp011@gmail.com](mailto:sunpe.rp011@gmail.com)

Item No.	Part Name	Material	Process	Quantity	Price
11	bracket_post	Aluminum	CNC	15	EUR 300
		<b>Size:</b> Max X:40.000 mm Max Y:50.992 mm Max Z:40.000 mm  <b>Volume:17896 mm3</b>  Surface finish:Powder coating, Black, Satin		Note:Weld to "Tube big"	
12	tube_big	Aluminum	Sheet Metal	15	EUR 640
		<b>Size:</b> Max X:40.000 mm Max Y:152.000 mm Max Z:40.000 mm  <b>Volume:60585 mm3</b>  Surface finish:Powder coating, Black, Satin			
13	tube_smal	Aluminum	Sheet Metal	15	EUR 640
		<b>Size:</b> Max X:32.000 mm Max Y:175.000 mm Max Z:60.000 mm  <b>Volume:58924 mm3</b>  Surface finish:Powder coating, Black, Satin			
14	slider_front_bracket_left	Aluminum	Sheet Metal	15	EUR 1,040
		<b>Size:</b> Max X:142.112 mm Max Y:38.689 mm Max Z:160.982 mm  <b>Volume:52654 mm3</b>  Surface finish:Powder coating, Black, Satin		Note:Weld to "slider frame"	
15	slider_front_bracket_right	Aluminum	Sheet Metal	15	EUR 1,040
		<b>Size:</b> Max X:142.112 mm Max Y:38.689 mm Max Z:160.982 mm  <b>Volume:52568 mm3</b>  Surface finish:Powder coating, Black, Satin		Note:Weld to "slider frame"	

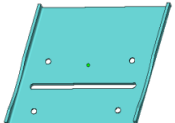
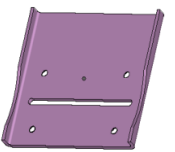
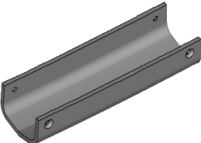
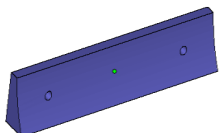
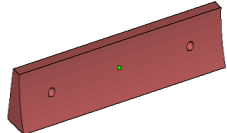


# Prototypes Quotation

Quotation No.:SP18SA006-20180327C

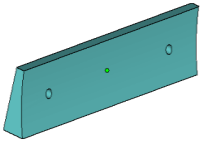
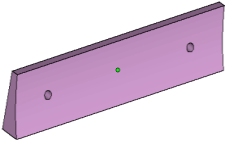
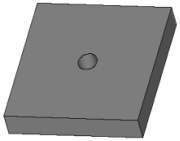
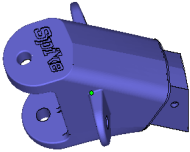
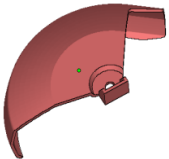
Client No.: SP18SA006  
 Client: Exero Technologies AS  
 Phone.: +47 905 13 537  
 Fax.:  
 Contact: Andre Haig Johnsen  
 Website: <http://www.exerotech.com>  
 E-mail: [andre@exerotech.com](mailto:andre@exerotech.com)

Provider: SUNPE LIMITED  
 Address: No.70 Tongxing Xi Rd, Dongsheng town,  
 Zhongshan city, GuangDong, 528415, P.R.China,  
 Tel.: +86 (0) 760 22825560,22825561,22825562,22825563  
 Fax.: +86 (0) 760 22211992  
 Contact: Daisy Zheng  
 Website: <http://www.sunpe.com>  
 E-mail: [RP\\_11@sunpe.com](mailto:RP_11@sunpe.com), [sunpe.rp011@gmail.com](mailto:sunpe.rp011@gmail.com)

Item No.	Part Name	Material	Process	Quantity	Price (EUR)
16	slider_rear_bracket_left	Aluminum	Sheet Metal	15	EUR 1,040
		<b>Size:</b> Max X:121.321 mm Max Y:18.064 mm Max Z:159.259 mm  <b>Volume:50949 mm3</b>  Surface finish:Powder coating, Black, Satin		Note:Weld to "slider frame"	
17	slider_rear_bracket_right	Aluminum	Sheet Metal	15	EUR 1,040
		<b>Size:</b> Max X:121.321 mm Max Y:18.064 mm Max Z:159.259 mm  <b>Volume:51020 mm3</b>  Surface finish:Powder coating, Black, Satin		Note:Weld to "slider frame"	
18	slider_frame	Aluminum	Sheet Metal	30	EUR 2,300
		<b>Size:</b> Max X:58.400 mm Max Y:69.753 mm Max Z:192.395 mm  <b>Volume:81801 mm3</b>  Surface finish:Powder coating, Black, Satin			
19	support_guide_1	ABS	CNC	30	EUR 720
		<b>Size:</b> Max X:29.000 mm Max Y:132.959 mm Max Z:12.349 mm  <b>Volume:28353 mm3</b>  Surface finish:Painting, Dark orange, Satin			
20	support_guide_2	ABS	CNC	30	EUR 720
		<b>Size:</b> Max X:29.000 mm Max Y:132.959 mm Max Z:12.349 mm  <b>Volume:28353 mm3</b>  Surface finish:Painting, Dark orange, Satin			

Client No.: SP18SA006  
 Client: Exero Technologies AS  
 Phone.: +47 905 13 537  
 Fax.:  
 Contact: Andre Haig Johnsen  
 Website: <http://www.exerotech.com>  
 E-mail: [andre@exerotech.com](mailto:andre@exerotech.com)

Provider: SUNPE LIMITED  
 Address: No.70 Tongxing Xi Rd, Dongsheng town,  
 Zhongshan city, GuangDong, 528415, P.R.China.  
 Tel.: +86 (0) 760 22825560,22825561,22825562,22825563  
 Fax.: +86 (0) 760 22211992  
 Contact: Daisy Zheng  
 Website: <http://www.sunpe.com>  
 E-mail: [RP\\_11@sunpe.com](mailto:RP_11@sunpe.com), [sunpe.rp011@gmail.com](mailto:sunpe.rp011@gmail.com)

Item No.	Part Name	Material	Process	Quantity	Price
21	support_guide_2	ABS	CNC	30	EUR 720
		<b>Size:</b> Max X:29.000 mm Max Y:132.959 mm Max Z:12.349 mm  <b>Volume:28353 mm3</b>  Surface finish:Painting, Dark orange, Satin			
22	support_guide_4	ABS	CNC	30	EUR 720
		<b>Size:</b> Max X:29.000 mm Max Y:132.959 mm Max Z:12.349 mm  <b>Volume:28353 mm3</b>  Surface finish:Painting, Dark orange, Satin			
23	t-lock_bit	Stainless Steel	CNC	120	EUR 640
		<b>Size:</b> Max X:18.000 mm Max Y:4.000 mm Max Z:18.000 mm  <b>Volume:995 mm3</b>  Surface finish:Powder coating, Black, Satin			
24	profile_end	Aluminum	CNC/Laser/EDM	30	EUR 4,480
		<b>Size:</b> Max X:110.000 mm Max Y:89.414 mm Max Z:155.210 mm  <b>Volume:161546 mm3</b>  Surface finish:Powder coating, Black, Logo can be coated Satin, Dark orange			
25	mud_guard_right	ABS	CNC	1	EUR 153
		Silicone	Rapid Mould	2	EUR 413
		PU 8150	Vacuum Casting	30	EUR 832
		<b>Size:</b> Max X:77.199 mm Max Y:129.416 mm Max Z:192.933 mm  <b>Volume:79014 mm3</b>  Surface finish:Black, Satin			

Client No.: SP18SA006  
 Client: [Exero Technologies AS](http://www.exerotech.com)  
 Phone.: +47 905 13 537  
 Fax.:  
 Contact: [Andre Haig Johnsen](mailto:andre@exerotech.com)  
 Website: <http://www.exerotech.com>  
 E-mail: [andre@exerotech.com](mailto:andre@exerotech.com)

Provider: SUNPE LIMITED  
 Address: No.70 Tongxing Xi Rd, Dongsheng town,  
 Zhongshan city, GuangDong, 528415, P.R.China,  
 Tel.: +86 (0) 760 22825560,22825561,22825562,22825563  
 Fax.: +86 (0) 760 22211992  
 Contact: Daisy Zheng  
 Website: <http://www.sunpe.com>  
 E-mail: [RP\\_11@sunpe.com](mailto:RP_11@sunpe.com), [sunpe.rp011@gmail.com](mailto:sunpe.rp011@gmail.com)

Item No.	Part Name	Material	Process	Quantity	Price
		ABS	CNC	1	EUR 153
26	mud_guard_left	Silicone	Rapid Mould	2	EUR 413
		PU 8150	Vacuum Casting	30	EUR 832
		 <p><b>Size:</b>            Max X:77.199 mm            Max Y:129.416 mm            Max Z:192.933 mm</p> <p><b>Volume:79015 mm3</b></p> <p>Surface finish:Black, Satin</p>			
27	calf_support_left	ABS	CNC	1	EUR 230
		Silicone	Rapid Mould	1	EUR 433
		PU 8150	Vacuum Casting	15	EUR 580
 <p><b>Size:</b>            Max X:132.364 mm            Max Y:122.169 mm            Max Z:350.000 mm</p> <p><b>Volume:164189 mm3</b></p> <p>Surface finish:Black, Satin</p>					
28	calf_support_right	ABS	CNC	1	EUR 230
		Silicone	Rapid Mould	1	EUR 433
		PU 8150	Vacuum Casting	15	EUR 580
 <p><b>Size:</b>            Max X:132.370 mm            Max Y:122.169 mm            Max Z:350.000 mm</p> <p><b>Volume:164193 mm3</b></p> <p>Surface finish:Black, Satin</p>					
29	knee_support	ABS	CNC	1	EUR 146
		Silicone	Rapid Mould	2	EUR 413
		PU 8150	Vacuum Casting	30	EUR 740
 <p><b>Size:</b>            Max X:149.970 mm            Max Y:79.000 mm            Max Z:200.000 mm</p> <p><b>Volume:131602 mm3</b></p> <p>Surface finish:Black, Satin</p>					

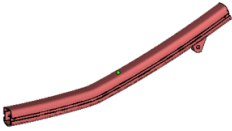
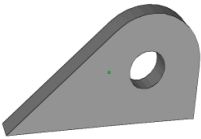


# Prototypes Quotation

Quotation No.:SP18SA006-20180327C

Client No.: SP18SA006  
 Client: Exero Technologies AS  
 Phone.: +47 905 13 537  
 Fax.:  
 Contact: Andre Haig Johnsen  
 Website: <http://www.exerotech.com>  
 E-mail: [andre@exerotech.com](mailto:andre@exerotech.com)

Provider: SUNPE LIMITED  
 Address: No.70 Tongxing Xi Rd, Dongsheng town,  
 Zhongshan city, GuangDong, 528415, P.R.China.  
 Tel.: +86 (0) 760 22825560,22825561,22825562,22825563  
 Fax.: +86 (0) 760 22211992  
 Contact: Daisy Zheng  
 Website: <http://www.sunpe.com>  
 E-mail: [RP\\_11@sunpe.com](mailto:RP_11@sunpe.com), [sunpe.rp011@gmail.com](mailto:sunpe.rp011@gmail.com)

30	main_profile	Steel	Mould	1	EUR 600
		AL6063	Extrusion	15	EUR 280
		AL6063	Sheet Metal	15	EUR 0
		<b>Size:</b> Max X:50.000 mm Max Y:105.060 mm Max Z:771.588 mm  <b>Volume:515034 mm3</b>  Surface finish:Powder coating, Black, Satin			Note: Only provide straight extrusion and weld, bend is not included
31	shell_2_of_main_profile	AL6063	Sheet Metal	30	EUR 138
		<b>Size:</b> Max X:5.000 mm Max Y:35.141 mm Max Z:52.945 mm  <b>Volume:4634 mm3</b>  Surface finish:Powder coating, Black, Satin			
<b>Total Prototyping Cost:</b>					<b>EUR 36,829</b>
<b>2. Logistic Fee (Delivered by DHL Express Airway)</b>					
Item No.	IGES/STEP/STL file name	Gross volume	Destination	Qty	Total volume
1~31	Item 1 to item 31		Norway	15 sets	400kg
				Sum:	400kg
				<b>Estimated Freight:</b>	<b>EUR 2,228</b>
DHL: Light weight cargo's freight based on package's gross volume.					
<b>3. Time</b>					
	Prototypes+After treatment+Painting (working days)	DHL collect parcel (working days)	Delivery to destination (working days)	Total (working days)	
	15	1	2	<b>18</b>	
<b>4.Summary</b>					
	Prototypes+After treatment+Painting	DHL Freight	Total Expense	Total period	
	EUR 36,829	EUR 2,228	<b>EUR 39,057</b>	<b>18</b>	
<b>5. Others</b>					
5.1.	<b>Knowledge property right</b>	Service provider should protect the knowledge property right of client, and keep secret for client.			
5.2.	<b>Customs duty and other local tax in destination country</b>	Client pay customs duty and other local tax in destination country, if happened.			
5.3.	<b>Period of validity for quotation</b>	One calendar month after quotation issued.			



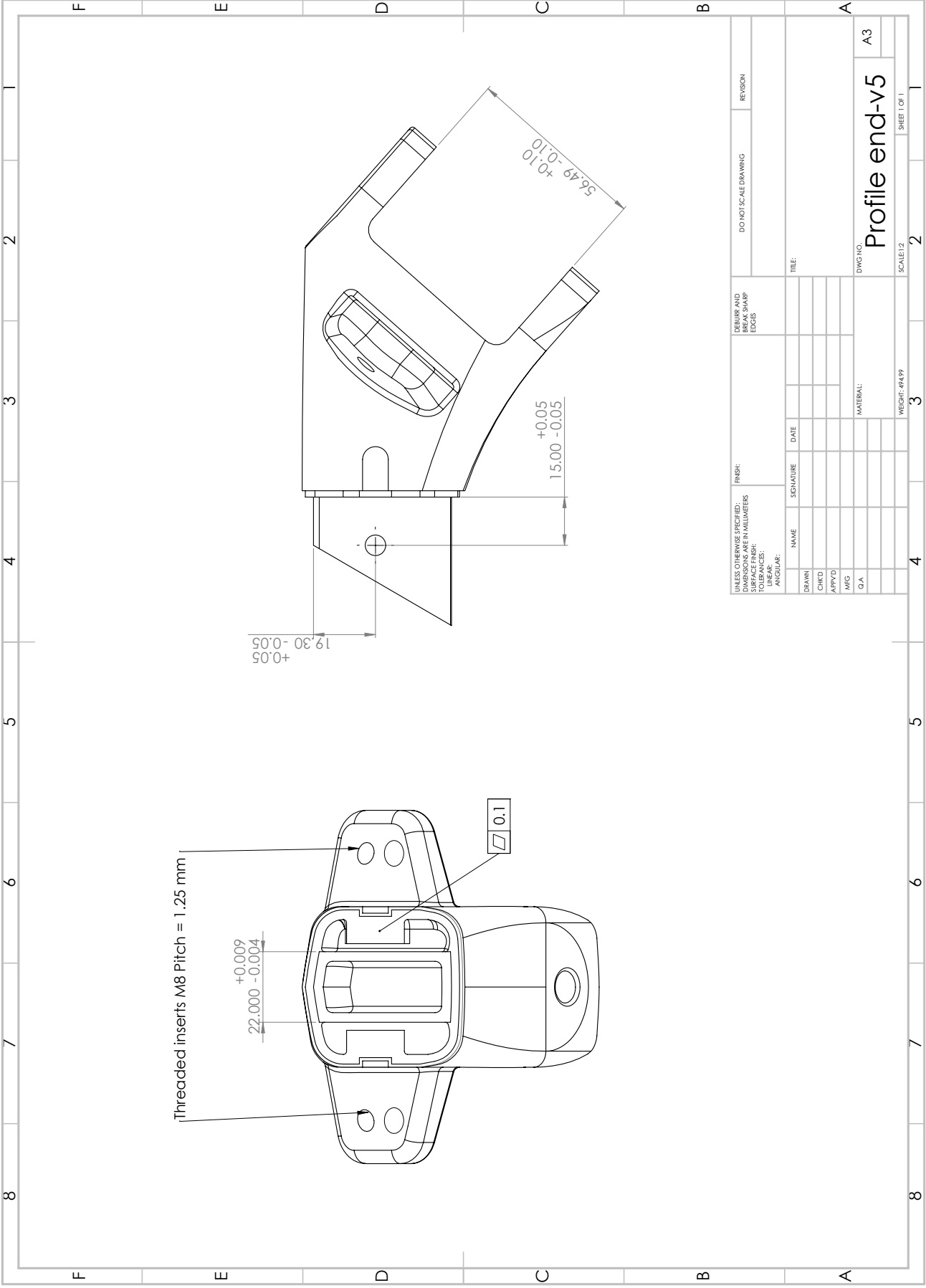
# C

## Production Drawings

### C.1 Main Frame Profile



## C.2 Profile End



UNLESS OTHERWISE SPECIFIED, DIMENSIONS ARE IN MILLIMETERS		FINISH: DO NOT SCALE DRAWING		REVISION	
SURFACE FINISH: TOLERANCES: ANGULAR:		BREAKS AND BREAK SHARP EDGES			
DRAWN	NAME	SIGNATURE	DATE	TITLE:	
CHKD					
APP'D					
MKG				MATERIAL:	
QA				DWG NO. <b>Profile end-v5</b>	
				A3	
				SCALE: 1:1	
				WEIGHT: 494.99	
				SHEET 1 OF 1	

# D

## Data Sheets

### D.1 Aluminum 6061-T6

## SPECIFICATIONS

Commercial	6061
EN	6061

Aluminium alloy 6061 is a medium to high strength heat-treatable alloy with a strength higher than 6005A. It has very good corrosion resistance and very good weldability although reduced strength in the weld zone. It has medium fatigue strength. It has good cold formability in the temper T4, but limited formability in T6 temper. Not suitable for very complex cross sections.

### Applications

Alloy 6061 is typically used for heavy duty structures in:

- ~ Rail coaches
- ~ Truck frames
- ~ Ship building
- ~ Bridges and Military bridges
- ~ Aerospace applications including helicopter rotor skins
- ~ Tube
- ~ Pylons and Towers
- ~ Transport
- ~ Boilermaking
- ~ Motorboats
- ~ Rivets

## CHEMICAL COMPOSITION

BS EN 573-3:2009  
Alloy 6061

Element	% Present
Magnesium (Mg)	0.80 - 1.20
Silicon (Si)	0.40 - 0.80
Iron (Fe)	0.0 - 0.70
Copper (Cu)	0.15 - 0.40
Chromium (Cr)	0.04 - 0.35
Zinc (Zn)	0.0 - 0.25
Titanium (Ti)	0.0 - 0.15
Manganese (Mn)	0.0 - 0.15
Others (Total)	0.0 - 0.15
Other (Each)	0.0 - 0.05
Aluminium (Al)	Balance

## TEMPER TYPES

The most common temper for 6061 aluminium is:

- T6 - Solution heat treated and artificially aged

## SUPPLIED FORMS

Alloy 6061 is typically supplied as

- Extrusions

## GENERIC PHYSICAL PROPERTIES

Property	Value
Density	2.70 g/cm <sup>3</sup>
Melting Point	650 °C
Thermal Expansion	23.4 x10 <sup>-6</sup> /K
Modulus of Elasticity	70 GPa
Thermal Conductivity	166 W/m.K
Electrical Resistivity	0.040 x10 <sup>-6</sup> Ω .m

## MECHANICAL PROPERTIES

BS EN 755-2:2008  
Extrusions

Up to 200mm Dia. & A/F, 5mm WT for Tube and Prof

Property	Value
Proof Stress	240 Min MPa
Tensile Strength	260 Min MPa
Hardness Brinell	95 HB

## WELDABILITY

Weldability – Gas: Good  
Weldability – Arc: Very Good  
Weldability – Resistance: Good  
Brazability: Good  
Solderability: Good

## FABRICATION

Workability – Cold: Good  
Machinability: Acceptable

## CONTACT

**Address:** Please make contact directly with your local service centre, which can be found via the Locations page of our web site  
**Web:** [www.aalco.co.uk](http://www.aalco.co.uk)

## REVISION HISTORY

**Datasheet Updated** 11 January 2016

## DISCLAIMER

This Data is indicative only and as such is not to be relied upon in place of the full specification. In particular, mechanical property requirements vary widely with temper, product and product dimensions. All information is based on our present knowledge and is given in good faith. No liability will be accepted by the Company in respect of any action taken by any third party in reliance thereon.

Please note that the 'Datasheet Update' date shown above is no guarantee of accuracy or whether the datasheet is up to date.

The information provided in this datasheet has been drawn from various recognised sources, including EN Standards, recognised industry references (printed & online) and manufacturers' data. No guarantee is given that the information is from the latest issue of those sources or about the accuracy of those sources.

Material supplied by the Company may vary significantly from this data, but will conform to all relevant and applicable standards.

As the products detailed may be used for a wide variety of purposes and as the Company has no control over their use; the Company specifically excludes all conditions or warranties expressed or implied by statute or otherwise as to dimensions, properties and/or fitness for any particular purpose, whether expressed or implied.

Advice given by the Company to any third party is given for that party's assistance only and without liability on the part of the Company. All transactions are subject to the Company's current Conditions of Sale. The extent of the Company's liabilities to any customer is clearly set out in those Conditions; a copy of which is available on request.

## D.2 Acrylonitrile butadiene styrene (ABS)



# Technical data sheet ABS

Ultimaker

Chemical Name	Acrylonitrile butadiene styrene
Description	Used by an array of industries worldwide, ABS is known for its exceptional mechanical properties. Our ABS is specifically formulated to minimize warping and ensure consistent interlayer adhesion.
Key features	Excellent mechanical properties and interlayer adhesion (especially when using the front door add-on), nice aesthetics, minimal warping and reliable bed adhesion.
Applications	Visual and functional prototyping and short run manufacturing.
Non suitable for	Food contact and in-vivo applications. Long term UV exposure can negatively affect properties of an ABS print. Applications where the printed part is exposed to temperatures higher than 85 °C.

## Filament specifications

	<u>Value</u>	<u>Method</u>
Diameter	2.85±0.10 mm	-
Max roundness deviation	0.10 mm	-
Net filament weight	750 g	-

## Color information

<u>Color</u>	<u>Color code</u>
ABS Black	RAL 9017
ABS White	RAL 9003
ABS Red	RAL 3020
ABS Blue	RAL 5002
ABS Silver	RAL 9006
ABS Pearl Gold	RAL 1036
ABS Green	RAL 6018
ABS Orange	RAL 2008
ABS Yellow	RAL 1023
ABS Gray	RAL 7011

## Mechanical properties (\*)

## Injection molding

## 3D printing

	<b>Typical value</b>	<b>Test method</b>	<b>Typical value</b>	<b>Test method</b>
Tensile modulus	2030 MPa	ISO 527 (1 mm/min)	1681.5 MPa	ISO 527 (1 mm/min)
Tensile stress at yield	43.6 MPa	ISO 527 (50 mm/min)	39.0 MPa	ISO 527 (50 mm/min)
Tensile stress at break	-	-	33.9 MPa	ISO 527 (50 mm/min)
Elongation at yield	4.8 %	ISO 527 (50 mm/min)	3.5 %	ISO 527 (50 mm/min)
Elongation at break	34 %	ISO 527 (50 mm/min)	4.8 %	ISO 527 (50 mm/min)
Flexural strength	-	-	70.5 MPa	ISO 178
Flexural modulus	-	-	2070.0 MPa	ISO 178
Izod impact strength, notched (at 23°C)	-	-	10.5 kJ/m <sup>2</sup>	ISO 180
Charpy impact strength (at 23°C)	58 kJ/m <sup>2</sup>	ISO 179	-	-
Hardness	97 (Shore A)	-	-	-

## Thermal properties

### Typical value

### Test method

Melt mass-flow rate (MFR)	41 g/10 min	ISO 1133 (260 °C, 5 kg)
Heat deflection (HDT) at 0.455 MPa	-	-
Heat deflection (HDT) at 1.82 MPa	-	-
Glass transition	97 °C	ISO 306
Coefficient of thermal expansion (flow)	-	-
Coefficient of thermal expansion (xflow)	-	-
Melting temperature	225-245 °C	ISO 294
Thermal shrinkage	-	-

## Other properties

### Typical value

### Test method

Specific gravity	1.10	ISO 1183
Flame classification	-	-

(\*) See notes.

### D.3 Polyurethane (PUR)

<b>Product Data Sheet</b>	<b>Datenblatt</b>	<b>8051</b>
---------------------------	-------------------	-------------

Properties	Eigenschaften	rigid & high temperature / hart & hochtemperaturbeständig
Colour	Farbe	white / weiss

		Unit / Einheit		Test / ISO				
Hardness Shore A/D	Härte Shore A/D	@ 23°C @ 60°C @ 80°C	84 D 78 D 77 D	868				
Flexural E-Modulus	Biege - E-Modul	MPa	1965	178				
Flexural Strength	Biegefestigkeit	MPa	85,9	178				
Tensile E-Modulus	Zug – E-Modul	MPa	2150	R 527				
Tensile Strength	Zugfestigkeit	MPa	55,9	R 527				
Heat Deflection Temp.(HDT) Testpiece 110 x 12,7 x 6,4 mm	Wärmeformbeständigkeit (HDT) Prüfstab 110 x 12,7 x 6,4 mm	C°	92					
Glass Transition Temperature °C (Tg)	Glasübergangstemperatur °C (Tg)	C°	110					
Elongation Yield	Dehnung	%	5					
Elongation Break	Bruchdehnung	%	8	R 527				
Tear Strength	Reißfestigkeit	MPa	-	34				
Yield Strength	Streckgrenze	MPa	62	R 527				
Izod Impact	Kerbschlagzähigkeit	Kj/m <sup>2</sup>	9,8	180				
Thermal Conductivity	Wärmeleitfähigkeit	W/mk	0,225	BS874				
Specific Gravity (@ 23°C) Part A Part B	Spezifi. Gewicht (@ 23°C) Komp. A Komp. B	kg/dm <sup>3</sup>	1,120 1,190					
Viscosity (@ 23°C) Part A Part B	Viskosität (@ 23°C) Komp. A Komp. B	cPs	750 180					
Mixing Ratio (Poly A : Iso B) By weight	Mischungsverhältnis (Poly A : Iso B) Nach Gewicht	g	<table border="1" style="display: inline-table; border-collapse: collapse;"><tr><td style="width:50%; text-align: center;"><b>A</b></td><td style="width:50%; text-align: center;"><b>B</b></td></tr><tr><td style="text-align: center;">100</td><td style="text-align: center;">200</td></tr></table>	<b>A</b>	<b>B</b>	100	200	
<b>A</b>	<b>B</b>							
100	200							
Pot Life (100g @ 23°C)	Topfzeit (100g @ 23°C)	sec.	300					
Curing Time (@ 70°C)	Aushärtezeit (@ 70°C)	min.	40					
Shrinkage According to Wall Thickness	Schrumpf Nach Schichtdicke	%	0,2-0,3					

POST CURING PROCESS / WÄRMEBEHANDLUNG		no / nein *



Back to Re – Ordering/  
Zurück zu Nachbestellungen

<b>Handling Procedure</b>	<b>Verarbeitungshinweise</b>	<b>8051</b>
---------------------------	------------------------------	-------------

Mixing ratio	Mischungsverhältnis	100 : 200
Pot life / sec. (100g @ 25°C)	Topfzeit / Sek. (100g @ 25°C)	300 sec. / Sek.
Resin temperature (C°) (Heating chamber)	Harztemperatur (C°) (Wärmeofen)	40°C
Mould temperature (C°) (Heating chamber)	Formtemperatur (C°) (Wärmeofen)	70°C
Mixing time (sec.)	Mischzeit (Sek.)	30 – 60 sec / Sek
Curing time in mould at 70°C (min.)	Aushärzeit in der Form bei 70°C (Min.)	40 min.
Post curing procedure	Wärmenachbehandlung	No / nein
Primary degassing (min.)	Vorentlüftung (Min.)	- -

<p style="text-align: center;"><b>Casting Procedure</b></p> <p>Weigh the resins. Measure remaining amount in Cup „A“ ! Place cups in the machine and start vacuum pump. Switch on mixer motor. After reaching max. vacuum level wait for 10 min before pouring „A „ into „ B „ cup. Mix resins as fast as possible. Pour resin into silicone mould and leak vacuum chamber before the end of pot life..</p>	<p style="text-align: center;"><b>Gießvorgang</b></p> <p>Gießharze abwiegen. Restmenge in Becher „A“ beachten ! Becher in die Maschine einsetzen. Vakuumpumpe starten. Rührer einschalten. Nach Erreichen des max. Vakuums 10 Min warten. Komponenten vermischen ( A in B ). Rührer so schnell wie möglich bewegen. Harz in die Silikonform gießen . Vakuumkammer innerhalb der Topfzeit belüften.</p>
<p><b>Special Notes</b></p> <p>Mould temperature is important. Shake „A“ and „B“ component cans before use. Use no more than 1 - 2 % colour pigment</p>	<p><b>Bemerkungen</b></p> <p>Auf exakte Formtemperatur achten. A und B Komponente vor Gebrauch schütteln. Farbzugabe max. 1-2 %.</p>
<p><b>Product information</b></p> <p>8051 can be supplied with long potlife „A“ – component ( LP / A ) Pot life 10 min. ( More info from MCP / HEK )</p>	<p><b>Produkt – Info</b></p> <p>8051 ist auch mit einer LP/A Komponente lieferbar . Topfzeit 10 Min. (Nähere Informationen bei MCP / HEK)</p>
<p><b>Mould life</b></p> <p>Mould life can be increased by demoulding the casting immediately after curing. Components over 2 mm thick in, 8051 can be de-moulded in 30 min. but need to be cured for a further 60 min at 70°C.</p>	<p><b>Standzeit der Silikonform</b></p> <p>Die Standzeit der Silikonform verlängert sich, wenn die Abgüsse unmittelbar nach Ablauf der Aushärzeit entformt werden. Ab einer Wandstärke von ca. 2mm, kann 8051 bereits nach 30 Min. entformt werden , die Abgüsse müssen allerdings anschließend noch 30 Min. bei 70°C getempert werden.</p>
<p><b>Storage of unopened cans</b></p> <p>20 ° C / protect against frost</p> <p><b>Storage of opened cans</b></p> <p>Place cans with closed caps in the oven at 40° C</p>	<p><b>Lagerung - geschlossene Gebinde</b></p> <p>Lagertemperatur 20° C / vor Frost schützen</p> <p><b>Lagerung - angebrochene Gebinde</b></p> <p>Angebrochene Gebinde gut verschließen, bei 40° C im Heizschrank lagern.</p>
<p><b>In case of crystallisation of B-component</b></p> <p>Place „ B “ can in oven at 70° C for 2- 4 hours and stir resin afterwards.</p>	<p><b>Bei Kristallisation der B - Komponente</b></p> <p>B - Komponente ca. 2 - 4 Std. in den Heizschrank stellen ( 70° C ), anschließend umrühren.</p>



Back to Re – Ordering/  
Zurück zu Nachbestellungen

E

Master Thesis Research  
Project



## **Finalizing Exero's Spike™ prototype for production**

Optimization and further development of adaptability, design,  
materials and manufacturing of the Spike™

Thesis Research Project in Product Development and Materials Programme

ANDRE HAIG JOHNSEN



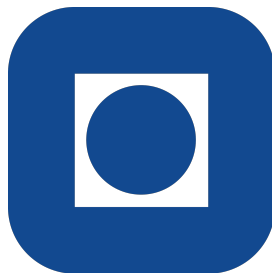


THESIS RESEARCH PROJECT 2017

# Finalizing Exero's Spike™ prototype for production

Optimization and further development of adaptability, design, materials and manufacturing of the Spike™

ANDRE HAIG JOHNSEN



NTNU

Department of Mechanical Engineering  
Exero Technologies  
NORWEGIAN UNIVERSITY OF SCIENCE AND TECHNOLOGY  
Beijing, China 2017

Finalizing Exero's Spike™ prototype for production  
Optimization and further development of adaptability, design, materials and manufacturing of the Spike™  
ANDRE HAIG JOHNSEN

© ANDRE HAIG JOHNSEN, 2017.

Supervisor: Knut Aasland, Department of Mechanical Engineering  
Examiner: Knut Aasland, Department of Mechanical Engineering

Thesis Research Project 2017  
Department of Mechanical Engineering  
Exero Technologies  
Norwegian University of Science and Technology  
Hoegskoleringen 1, 7491 Trondheim, Norway  
Telephone +47 73 59 50 00

Cover: PNG of the current prototype, Spike™.

Typeset in L<sup>A</sup>T<sub>E</sub>X  
Beijing, China 2017

## Abstract

Exero Technologies develop adaptive sports equipment for people with disabilities. The Spike™ is an exercise and entertainment product for people with disabilities below their waist. It is currently in beta prototyping phase. Exero Technologies want the Spike™ to be finalized and ready for the market.

This master thesis research project reviews different product development methodologies and determines which methods are best suited for finalizing the design of the Spike™. Methods such as Set-Based Design, Experience Prototyping and Minimum Viable Product are deemed most suited for this project. This research project also looks at manufacturing options for the Spike™, domestic and abroad. A local manufacturer in Trondheim, Norway is sufficient for producing the first 5-20 units of the Spike™. For mass production of 20+ units, 3a Prototyping in Zhongshan, China is a sufficient manufacturer.

The findings in this research project will be the basis for the the master thesis "Finalizing Exero's Spike™ prototype for production".

Keywords: Exero, Spike™, disabilities, optimization, adaptability, manufacturing, design, market, China.



## Acknowledgements

First and foremost, I have to thank my research supervisor **Mr Knut Aasland**. His assistance and openness to the project has allowed me to shape this thesis as I see fit. Allowing me to go to China for my research has changed the contents of the project for the better.

I would also like to thank the **Department of Production and Materials at the Norwegian University of Science and Technology** for sending me to Beijing, China for a semester. Thank you to the **Department of Mechanical Engineering at Tsinghua University** for accepting me.

I would also like to show gratitude to the following:

**Exero Technologies**, Company

**Dr Jingshan Zhao 赵景山**, at Tsinghua University

**Hao Han 鲲鹏**, CTO of ANNE

**Jessica Chen 陈玉春**, Sales at 3a Prototyping

**Franny Fan 范艳芳**, Sales at 3a Prototyping

**Alina Huang 黄川君**, Sales at StarRapid Prototyping

**Zachary Lam 林泳耀**, CEO of SCHNIF

**Arman Brushan Majedi**, Designer

Andre Haig Johnsen, Beijing, 11.12.2017



# Contents

<b>List of Figures</b>	<b>XI</b>
<b>List of Tables</b>	<b>XIII</b>
<b>1 Introduction</b>	<b>1</b>
1.1 Exero Technologies . . . . .	2
1.2 Exero Spike™ . . . . .	3
1.2.1 Testing and User Feedback . . . . .	4
1.3 Scope of Master Thesis . . . . .	5
1.4 Scope of Master Thesis Research Project . . . . .	5
<b>2 Product development theory</b>	<b>7</b>
2.1 New product development . . . . .	7
2.1.1 IDEO model . . . . .	8
2.1.2 Booz, Allen and Hamilton (BAH) Model . . . . .	8
2.1.3 Stage-Gate model . . . . .	9
2.1.4 IPM model . . . . .	10
2.2 Set-Based Design . . . . .	11
2.3 Prototyping . . . . .	12
2.4 Minimum Viable Product . . . . .	12
<b>3 Production and Manufacturing</b>	<b>15</b>
3.1 Requirements . . . . .	15
3.2 Trondheim, Norway . . . . .	16
3.2.1 Ula Jern . . . . .	17
3.3 Guangzhou, China . . . . .	18
3.3.1 Research methods . . . . .	18
3.3.2 Results . . . . .	19
3.3.2.1 3A Prototyping . . . . .	20
3.3.2.2 Star Rapid Prototyping . . . . .	22
<b>4 Discussion</b>	<b>25</b>
	<b>IX</b>

4.1	Product development theory . . . . .	25
4.2	Production and manufacturing . . . . .	26
<b>5</b>	<b>Conclusion</b>	<b>27</b>
	<b>Bibliography</b>	<b>29</b>
<b>A</b>	<b>Meeting Reports</b>	<b>I</b>
A.1	Telephone meeting with Jessica Chen i 3a Prototyping 20.11.2017 . . .	I
A.2	Telephone meeting with Alex Jian Wu Innovation Norway Beijing 22.11.2017 . . . . .	III
A.3	Meeting and factory visit StarRapid Prototyping 01.12.2017 . . . . .	V
A.4	Meeting and factory visit 3a Prototyping 01.12.2017 . . . . .	VIII
<b>B</b>	<b>Bachelor Thesis; Steering system for cross-country sit-skis, 2016</b>	<b>XI</b>



# List of Figures

1.1	Variants of cross-country sit-skiing . . . . .	1
1.2	The first off-road cross-country sit-ski prototype. . . . .	2
1.3	Exero Technologies logo . . . . .	2
1.4	Exero Spike™ . . . . .	3
1.5	Espen Aksnes testing the Spike™ . . . . .	4
2.1	Five-step IDEO model . . . . .	8
2.2	Seven-step BAH model . . . . .	9
2.3	Stage-Gate model . . . . .	10
2.4	Comparing set-based and point-based design approaches . . . . .	11
3.1	Ula Jern . . . . .	17
3.2	Guangdong province . . . . .	18
3.3	Top 10 aluminum factories in Guanzhao . . . . .	19
3.4	3a Prototyping . . . . .	20
3.5	CNC and EDM . . . . .	21
3.6	Die Casting . . . . .	21
3.7	Star Rapid Prototyping . . . . .	22
3.8	CNC . . . . .	23
3.9	Metal 3D-printing, 250x250x30 mm . . . . .	23
3.10	Delivery floor . . . . .	23
3.11	Quality control . . . . .	23



# List of Tables

3.1	Die casting prices . . . . .	21
3.2	Die casting prices . . . . .	24



# 1

## Introduction

Cross-country sit-skiing is a cross-country variant for people with disabilities in the lower part of their body. The user sits in a chair supported with a suspension over a pair of skis that ride in a track, see figure 1.1a. Cross-country sit-skiing is a sport for exercise and competition. The activity is classified as a discipline in the Paralympics.



(a) Cross-country sit-skiing. *Source: Boston Globe [1]*



(b) Cross-country sit-skiing on pavement. *Source: NRK [2]*

**Figure 1.1:** Variants of cross-country sit-skiing

An ongoing problem for this sport was the impractical training during the summer. By switching to roller skis and rolling on pavement, no modification was made in order to be able to maneuver the sit-ski. There is much less friction between the skis and pavement than during the winter. Therefore users must strenuously lift their torso to toggle the sit-ski in the desired direction, see figure 1.1b.

In the summer of 2016 a bachelor thesis out of Norway's University for Science and Technology, "Steering system for cross-country sit-skis", designed a solution for the maneuverability problem. They designed an off-snow cross-country sit-ski that was able to maneuver on pavement, see figure 1.2. The steering of the sit-ski is defined by the magnitude of the side-ways angle of the users upper body. Keeping the upper

body in straight upward position while propelling with poles, allows the sit-ski to move straight. Tilting to one side or the other during propulsion will steer the ski-ski in the tilted direction.



**Figure 1.2:** The first off-road cross-country sit-ski prototype.

*Source: Steering system for cross-country sit-skis [3]*

The group behind the bachelor thesis found much potential in their prototype and would later go on to create a start-up company at NTNU's School of Entrepreneurship under the name "Exero Technologies". Since the winter of 2017 the company has continued prototyping and are currently looking for a finalized market worthy product.

### 1.1 Exero Technologies

Exero Technologies is a startup company originating from NTNU's School of Entrepreneurship, see figure 1.3. The company was started February 2nd, 2016 and aims to develop and market the next centuries assistive sports equipment. The company consists of 5 people, of which all are founders. Three of the founders are students at NTNU's School of Entrepreneurship and two of the founders are students at NTNU's Department of Product Development and Materials. The author of this research project is one of founders of the company.



**Figure 1.3:** Exero Technologies logo

*Source: Exerotech [4]*

The company was founded on the potential of the NTNU bachelor thesis prototype. It was established that the end product would not only be for cross-country sit-skiers to use during the summer. Rather, it will be for *all healthy, injured or disabled users*

to use as exercise equipment or for entertainment. This gave birth to a whole **new and bigger market**.



**Figure 1.4:** Exero Spike™

*Source: Exerotech Database [5]*

The company has so far developed and tested several functional prototypes to verify the market and to define the product. They are currently finished with their latest prototype which they name the Spike™, see figure 1.4. The Spike™ is considered to be the last version in the prototype phase of the company. Future work includes finalizing the design of the Spike™ and finding manufacturers to make the product ready for the market. Furthermore, it is planned to deliver the first version of the product by the start of 2018.

## 1.2 Exero Spike™

The Exero Spike™ is the result of over one year of product development and prototyping. It is designed to meet all the functionality requirements of the product. The sit-ski is mounted onto a rig that has mountainboard trucks attached at each end, see figure 1.4.

The sit-ski seat can be radially adjusted. The knee and calf supports can be individually adjusted vertically on the sit-ski and the sit-ski itself can be moved vertically on the rig. The sit-ski and rig are made up of 25x25x2.5mm 6061 T6 aluminum profiles. The seat, knee and calf supports are made by casting plastic and are lay-

ered with closed-cell foams for cushioning. All supports have belt straps to hold the body in place. All adjustments are done through un-screwing M6 screws and bolts on the sit-ski and rig and re-screwing them in new positions.

A 6mm thick aluminum plate is welded at an angle of  $35^\circ$  at each end of the rig. Here, the Trampa Vertigo Trucks are attached with M4 screws and bolts. The trucks have one spring and damper on each side of the rotational center. These springs can be individually adjusted allowing for the possibility of moving the users weight symmetry on the Spike™. The Innova Slick Cut 8-inch tires are set up with hydraulic brakes on each of the two front wheels. The manual braking lever is mounted in the middle of the knee support, see figure 1.4.

### 1.2.1 Testing and User Feedback

Throughout the spring and summer of 2017 the Spike™ has been tested with over 30 different users with different paraplegia, see figure 1.5. Assessment reports from every user have been documented to give an overview and feedback of the user experience. The overall verdict is that the Spike™ meets all functionality requirements, but more **adjustability** to satisfy every user. There must be more adjustments to individual parts. Also, feedback has been received on poor **visual design**, tighter **strapping** and more comfortable **seating**.



**Figure 1.5:** Espen Aksnes testing the Spike™

*Source: Exerotech Database [4]*



### 1.3 Scope of Master Thesis

As of now, The Spike™ is a safe and functional product, yet not fully finalized for the consumer market. To achieve a market ready product the Spike™ must be further developed and optimized based on the users and engineers feedback. Also, materials and manufacturing methods and partners must be chosen. The scope of this master thesis will be to finalize a market ready version of Exero's Spike™ and determine manufacturing partners.

### 1.4 Scope of Master Thesis Research Project

A master thesis research project is considered a pre-study for the work to come. Every master thesis requires a research project to be submitted before being allowed to write a thesis. This is given as a prerequisite writing course to the thesis and is accomplished in the term period before; Fall 2017.

Further developing and optimizing the Spike™ design will require product development theory and method. Different methods are suited for certain products so finding the right method is crucial.

Currently there is only 1 unit of the Spike™. The manufacturing of all prototypes from Exero Technologies have come hiring individual workforce for that particular prototype. This is not sufficient for producing in larger quantities. Reliable manufacturing partners need to be established as well as location and method. This requires research and networking.

The author of this research project will be residing in Beijing, China from September to January 2017/2018. This allows for research and networking to be done on Chinese manufacturers and on a potential Chinese consumer market.

The scope of this research project will be to:

1. Find a suitable product development method for the optimization of the Spike™.
2. Find manufacturing partners and establish production location and method for the current and future production quantity of the Spike™.

3. Research and network the Chinese market and production methods.
4. Research die casting options in China

# 2

## Product development theory

Development of specific products require different processes. A product developer needs to have knowledge about a variety of product development methods. There are several different methods to use. Finding the model that is most beneficial to a project will have a major influence on the resulting product.

The purpose of this chapter is to review different product development methodologies and determine which models are the most suited for further development of the Spike™. These models can be molded around the project to create a new and unique model. Classic product development methods such as Ulrich and Eppinger will not be reviewed. The Spike™ is in the latter stages of design. Therefore this chapter will focus on new and flexible product development methods.

### 2.1 New product development

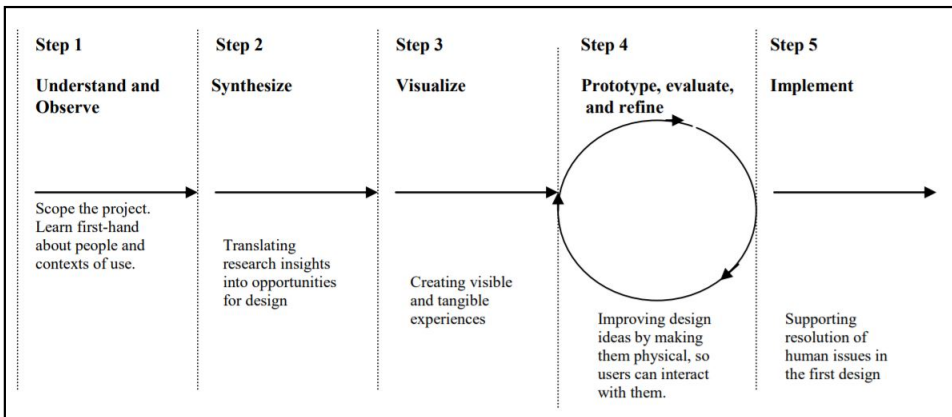
New product development (NPD) covers the complete process of bringing a new product to market. A central aspect of NPD is product design, along with various business considerations. New product development is described broadly as the transformation of a market opportunity into a product available for sale.[6] The product can be tangible or intangible. NPD requires an understanding of customer requirements, the competitive environment, and the nature of the market.[7]

In NPD every new product will pass through a series of phases, including ideation, aspects of design, manufacturing and market introduction. The product development process often include the following phases:

1. **Fuzzy front-end (FFE)** - Activities to determine product requirements in order to meet the market need.
2. **Product design** - Development of the high-level design for how the product will meet the requirements. For marketing, this phase ends at pre-commercialization analysis.
3. **Product implementation** - Detail design, prototyping and meeting all design specifications.
4. **Fuzzy back-end** - Production and market launch occur.

### 2.1.1 IDEO model

IDEO, a successful design and consulting firm, has one of the most researched processes in new product development. It is a five-step procedure, see figure 2.1.[8]

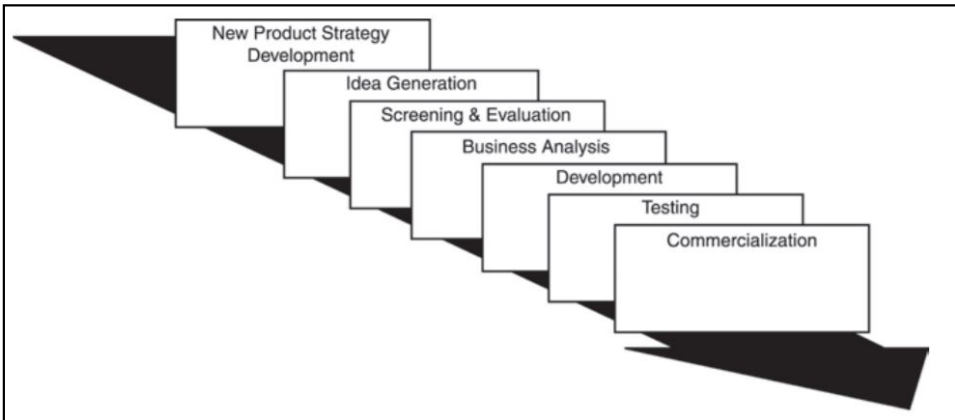


**Figure 2.1:** Five-step IDEO model

*Source: rwjf.org [8]*

### 2.1.2 Booz, Allen and Hamilton (BAH) Model

Although risk is inherent in NPD, it can be lessened by adopting a systematic framework for managing new product activities. The management consulting firm of Booz, Allen and Hamilton developed the BAH model managing new product activities. The BAH model is divided into seven sequential stages, see figure 2.2.

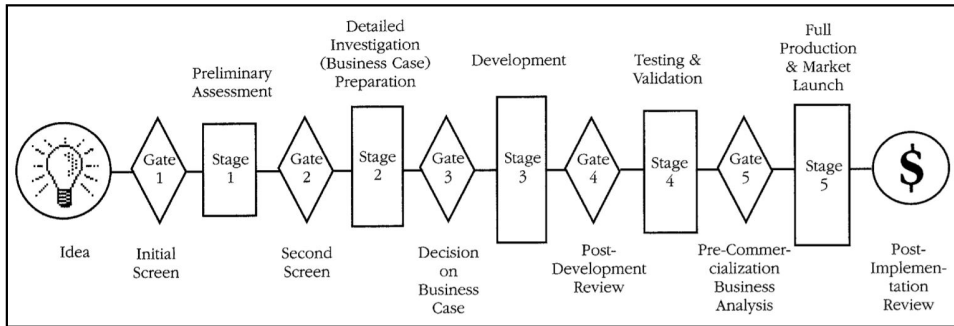


**Figure 2.2:** Seven-step BAH model

*Source: jppub.com [9]*

### 2.1.3 Stage-Gate model

Stage-Gate process was developed by Robert G. Cooper in 1980. The process is similar to NASA's Phase-Gate process and Winston Royce's waterfall process. Stage-gate process is a project management technique in which new product development is divided into stages, separated by control checkpoints (known as gates). A set of deliverables is specified for each gate, as is a set of quality criteria that the product must pass before moving to the next stage. The stages are where the work is done; the gates ensure that the quality is sufficient.[10] The stage must be repeated until the criteria is met. Usually, stage-gate systems involve four to seven stages and gates, see figure 2.3 for a typical system.



**Figure 2.3:** Stage-Gate model

Source: *ac.els-cdn.com* [10]

Parallel processing is an important feature of stage-gate systems. It means that activities are *parallel rather than sequential*. At each stage, many activities take place concurrently.[10]

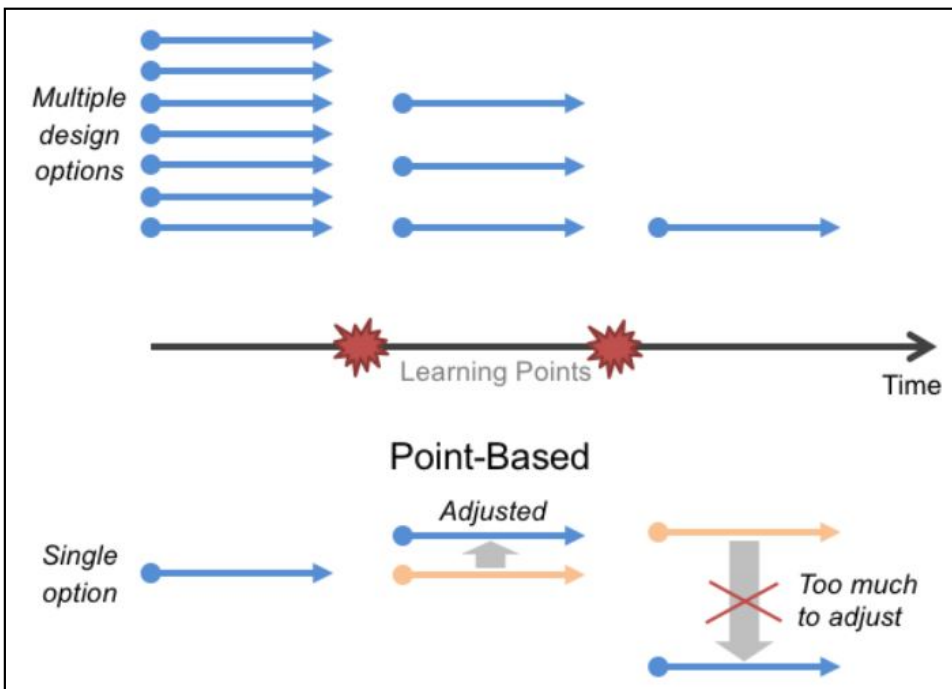
### 2.1.4 IPM model

The IPM model is product development model based on Robert G. Cooper's Stage-Gate model. A new phase cannot be started without finishing and fulfilling the milestones of the previous phase. Milestones are set before the phase begins. This type of product development reduces initial resources and makes it easy to measure progress. The IPM model consists of 5 stages, see list below:

1. **Vision** - Find which problem the product is solving, the product's importance and define a project description.
2. **Requirement and technology analysis** - Define the users demand and needs to so derive requirements for the product. Investigate the competitors in the market.
3. **Concept Development** - Define solutions that can be combined into concepts. Derive a minimum viable product or prototype from the best concept.
4. **Test and validation** - Testing technical solutions up against requirements. Derive cost calculations.
5. **Production start-up** - Find manufacturers and distribution channels. Finalize product for market and sale.

## 2.2 Set-Based Design

Set-Based Design(SBD) is a product development model that keeps design options and requirements flexible as long as possible during the design process. Point-Based Design product development decisions are made as soon as they are encountered, see figure 2.4. Instead of choosing single solutions, SBD identifies and simultaneously explores multiple options, eliminating poorer choices over time.[11] This allows for more resources to be used earlier in the process, which produces better economic results. Towards the end, SBD has fully exhausted the other technical solutions. This creates a certain validation for the final technical solution.



**Figure 2.4:** Comparing set-based and point-based design approaches

*Source: scaledagileframework.com [11]*

SBD provides an adaptive approach with a wider systems perspective, better economic choices, and more adaptability to existing constraints.[11]

## 2.3 Prototyping

A prototype is an early sample, model, or release of a product built to test a concept or process or to act as a thing to be replicated or learned from.[12] For engineers, prototyping is a way of reducing uncertainty by validating and verifying their assumptions and calculations from the product development process. Otto and Wood 2003, chronological list of types of prototypes in engineering design;

1. Proof of concept
2. Industrial design
3. DOE Experimental
4. Alpha
5. Beta
6. Pre-production

Buchenau and Suri 2000, introduce Experience Prototyping. The designers, clients and users have active engagement with prototypes. This helps the designer understand, explore or communicate what it is like to engage with the product. According to Buchenau and Suri, Experience Prototyping is particularly powerful in three activities within prototyping, see list below.

1. Understanding existing user experiences and context
2. Exploring and evaluating design ideas
3. Communicating ideas to an audience

Experience Prototyping is essentially a cheap and effective way to assess various parts of design or technical solution during the product development.[13]

## 2.4 Minimum Viable Product

One of the most important lean start-up techniques. A Minimum Viable Product (MVP) is a product with just enough features to satisfy early customers, and to provide feedback for future product development. Developers can deploy this product to a potential user as an early adopter. Giving a user a functional product with



less features gives more power to the user to give feedback on what is missing. If a company is in a constant reworking prototyping stage, this strategy lowers the cost, maximizes the information and avoids building products that customers do not want. The final, complete set of features is only designed and developed after considering feedback from the product's initial users. [14]



# 3

## Production and Manufacturing

As of now, the Spike™ and all the previous prototypes from Exero Technologies have been manufactured by individual workers. For ordering quantities of 1, individual workers are sufficient. It allowed the production to be more specified. Never the less, it was a high risk situation. There were no contracts between the parties and deadlines were rarely met. As the Spike™ design is being groomed for the market, so must the production. Exero Technologies is looking to find new manufacturing partners and professionalize their production. For the early, *low quantity* production of the Spike™, Exero is looking for a partnership with a local manufacturer in Trondheim, Norway. Keeping the production local makes it easier to make adjustments to the design and allows for iterative prototyping and adaptable design.

For the later, *high quantity* production of the Spike™, Exero is looking for international manufacturers. Guangdong, China is a country of interest as it has an emerging economy and cheap aluminum production. The author of this research project will be spending time in Beijing, China to research Chinese production options.

- **Low quantity:** 5-20 units
- **High quantity:** 20-100 units

### 3.1 Requirements

The current Spike™'s chassis is made up of 6061 T-6 aluminum square tubing. Material selection was researched and chosen in a previous bachelor thesis, see Appendix B. Currently the Spike™ is designed on standard profile tubing. Exero Technologies eventually wants to acquire a unique custom profile tubing through die casting. Therefore the potential manufacturer must provide this service. See list for the re-

quired materials and manufacturing processes for the potential manufacturer.

#### **List of required materials and manufacturing processes for a manufacturer**

- 6061-T6 aluminum tubing
- Plastics
- Cutting, boring, bending
- Welding
- CNC-machining
- Laser cutting
- Die casting
- Aluminum extrusion
- Plastic injection molding
- Vacuum casting
- 3D-printing aluminum
- 3D-printing plastics
- Surface finishing
- Surface coloring
- Quality control

## **3.2 Trondheim, Norway**

Trondheim is a city in Norway focused more on scientific technology development than production development. Methods for finding manufacturing partners in Trondheim included researching online, networking within the NTNU's School of Entrepreneurship community and communication with EGG's Design.

### 3.2.1 Ula Jern

Ula Jern is a freelancing workshop located in Rosendal, Trondheim, see figure 3.1. They design, manufacture and assemble all types of materials with a specific focus on steel, aluminum and stainless steel. They have connections with multiple aluminum suppliers and other manufacturers for outsourcing manufacturing processes.



**Figure 3.1:** Ula Jern

*Source: Ula Jern [15]*

A workshop visit in August 2017 generated a personal connection with the factory owner and gave an overview of the work space conditions and which manufacturing processes were available, see list.

#### Ula Jern's materials and manufacturing processes:

- |  |   |
|--|---|
| <input checked="" type="checkbox"/> 6061-T6 aluminum tubing  | <input checked="" type="checkbox"/> Aluminum extrusion        |
| <input checked="" type="checkbox"/> Plastics                 | <input checked="" type="checkbox"/> Plastic injection molding |
| <input checked="" type="checkbox"/> Cutting, boring, bending | <input checked="" type="checkbox"/> Vacuum casting            |
| <input checked="" type="checkbox"/> Welding                  | <input checked="" type="checkbox"/> 3D-printing aluminum      |
| <input checked="" type="checkbox"/> MAG                      | <input checked="" type="checkbox"/> 3D-printing plastics      |
| <input checked="" type="checkbox"/> MIG                      | <input checked="" type="checkbox"/> Surface finishing         |
| <input checked="" type="checkbox"/> TIG                      | <input checked="" type="checkbox"/> Anodizing                 |
| <input checked="" type="checkbox"/> CNC-machining            | <input checked="" type="checkbox"/> Sand blasting             |
| <input checked="" type="checkbox"/> Laser cutting            | <input checked="" type="checkbox"/> Surface coloring          |
| <input checked="" type="checkbox"/> Die casting              | <input checked="" type="checkbox"/> Quality Inspection        |

### 3.3 Guangzhou, China

China’s emerging manufacturing market has developed rapidly alongside its flourishing export trade. It is specifically centered in the south-east of China in the Guangdong province due to its harbor, see figure 3.2. Guangdong contributes approximately 12% of the total national economic output [17]. It is home to two of the fastest growing cities in the world, Shenzhen and Guangzhou. Both cities are heavily focused on innovation. Shenzhen is modernly referred to as the “Silicon Valley of Hardware” and develops more technical and electrical equipment. Guangzhou is referred to as the largest city in China dealing with traditional business. That excludes financial, technical and IT business. In Guangzhou business revolves around “material units” such as *fabric, metals, construction and agriculture*. Therefore, Guangzhou is naturally home to China’s largest aluminum economy.



**Figure 3.2:** Guangdong province  
*Source: Wikimedia [16]*

This chapter includes research on Guangzhou aluminum factories and manufacturers. It is of Exero’s interest to find out which processing methods these factories can offer, pricing for low volume production and pricing for die casting equipment.

#### 3.3.1 Research methods

Two major factors make it difficult for researching information in China. The first is the language barrier. All though most Chinese study English throughout elementary school, they are primarily taught to write and read, not to speak. Learning Chinese or having a translator is therefore a necessity when communicating with Chinese manufacturers.

Secondly, the limited internet. All Google services and many western websites are blocked in China. VPN solves this issue, but since the internet ban has existed for almost ten years, *Chinese companies have grown accustomed to publishing their work on Chinese websites*, such as Baidu(Chinese Google) and Zhihu(Chinese Quora).

Research methods include external online search on [www.baidu.cn](http://www.baidu.cn) and [www.zhuhu.cn](http://www.zhuhu.cn) and communicating with Tsinghua University advisors and Innovation Norway Beijing.

### 3.3.2 Results

Early research and phone calls with Alex Jian Wu of Innovation Norway Beijing and Jessica Chen of 3a Prototyping generated three revelations of the Chinese production market, see Appendix A.1 and A.2 for meeting report.

- Metal and construction factories in China operate on high volume manufacturing demand. Many manufacturers hang up the phone if the volume is lower than 100,000 units.
- Contracts and communication with Chinese factories are peer to peer rather than business to factory. Every factory assigns a contact personnel to each customer.
- **Networking** is the key to doing low volume business in the Chinese industry. Meeting, communicating and building relationships with factory contacts will change the dynamic of the business. Most factories know each other well and rely on outsourcing certain manufacturing processes. For low volume production this means most of the outsourcing must be done as "favors" to the factory.

Two low volume manufacturing factories were found as a result of online searching on Zhihu, see figure 3.3. With the list above in mind, it was necessary to travel and visit these factories to build relationships and expand the networking.

序列	品牌	公司名称
1	忠旺	辽宁忠旺集团有限公司
2	亚铝AAG	肇庆亚洲铝厂有限公司
3	兴发XINGFA	广东兴发铝业有限公司
4	凤铝FENLU	广东凤铝铝业有限公司
5	坚美JMA	广东坚美铝型材厂（集团）有限公司
6	南山NANSHAN	山东南山铝业股份有限公司
7	伟业WEIYE	广东伟业铝厂集团有限公司
8	伟昌WACANG	广东华昌铝厂有限公司
9	振升ZENSONG	长沙新振升集团有限公司
10	闽铝	福建省南平铝业股份有限公司

注：以上排名不分先后

**Figure 3.3:** Top 10 aluminum factories in Guanzhao

Source: Zhuhu [18]

### 3.3.2.1 3A Prototyping

3A Prototyping is a prototyping facility in Zhongshan, Guangdong, see figure 3.4. They offer functional prototypes, visible prototypes and concept prototypes by using a series of manufacturing processes. They specialize in rapid prototyping, low volume machining, rapid tooling, injection molding and aluminum extrusion. A factory visit was conducted through Jessica Chen on December 1st, 2017, see Appendix A.4 for meeting report.



**Figure 3.4:** 3a Prototyping  
*Source: 3a Prototyping [19]*

#### 3a Prototyping's materials and manufacturing processes:

- |  |   |
|--|---|
| <input checked="" type="checkbox"/> 6061-T6 aluminum tubing  | <input checked="" type="checkbox"/> 6082 T6                   |
| <input checked="" type="checkbox"/> Plastics                 | <input checked="" type="checkbox"/> Plastic injection molding |
| <input checked="" type="checkbox"/> ABS                      | <input checked="" type="checkbox"/> Vacuum casting            |
| <input checked="" type="checkbox"/> PC                       | <input checked="" type="checkbox"/> 3D-printing aluminum      |
| <input checked="" type="checkbox"/> HDPE                     | <input checked="" type="checkbox"/> 3D-printing plastics      |
| <input checked="" type="checkbox"/> Cutting, boring, bending | <input checked="" type="checkbox"/> Surface finishing         |
| <input checked="" type="checkbox"/> Welding                  | <input checked="" type="checkbox"/> Anodizing                 |
| <input checked="" type="checkbox"/> MAG                      | <input checked="" type="checkbox"/> Bead blasting             |
| <input checked="" type="checkbox"/> MIG                      | <input checked="" type="checkbox"/> Sand blasting             |
| <input checked="" type="checkbox"/> TIG                      | <input checked="" type="checkbox"/> Surface coloring          |
| <input checked="" type="checkbox"/> CNC-machining            | <input checked="" type="checkbox"/> Powder coating            |
| <input checked="" type="checkbox"/> Laser cutting            | <input checked="" type="checkbox"/> Painting                  |
| <input checked="" type="checkbox"/> Die casting              | <input checked="" type="checkbox"/> Printing                  |
| <input checked="" type="checkbox"/> Aluminum extrusion       | <input checked="" type="checkbox"/> Etching                   |
| <input checked="" type="checkbox"/> 6061 T6                  | <input checked="" type="checkbox"/> Quality Inspection        |
| <input checked="" type="checkbox"/> 6063 T6                  |   |

The 3a Prototyping facility provides CNC-machining, EDM, plastic injection molding and surface finish and color, see figure 3.5. Welding, laser cutting, aluminum extrusion and die casting are outsourced to factories nearby, see figure 3.6





**Figure 3.5:** CNC and EDM

*Source: Exero database [5]*



**Figure 3.6:** Die Casting

*Source: Exero database [5]*

3a Prototyping charges 800 RMB for every die cast set-up. They can provide the following prices for die casting, see table 3.1.

**Table 3.1:** Die casting prices

Die Casting Aluminum	
Shape	Price/cast
Circular/Square	3000 RMB
Elliptical	4000 RMB
Custom	5000 RMB
Detailed	7000 RMB

3a Prototyping have a minimum of 50 units per order. This limit is lowered to minimum 5 units per order for Exero Technologies. Price per unit will vary outside the following intervals; 5-20, 20-50, 50-100, 100-500, 500-2000.

### 3.3.2.2 Star Rapid Prototyping

Star Rapid Prototyping is a prototyping facility in Zhongshan, Guangdong, see figure 3.7. Star Rapid provides high-quality prototyping, rapid tooling and low-volume manufacturing services. A factory visit was conducted through Alina Huang on December 1st, 2017, see Appendix A.3 for meeting report.



**Figure 3.7:** Star Rapid Prototyping  
*Source: Star Rapid Prototyping [20]*

#### Star Rapid Prototyping's materials and manufacturing processes:

- ✓ 6061-T6 aluminum tubing
- ✓ Plastics
  - ✓ ABS
  - ✓ PC
  - ✓ HDPE
- ✓ Cutting, boring, bending
- ✓ Welding
  - ✓ MAG
  - ✓ MIG
  - ✓ TIG
- ✓ CNC-machining
  - ✓ 5-axis
- ✓ Laser cutting
- ✓ Die casting
- ✓ Aluminum extrusion
  - ✓ 6061 T6
  - ✓ 6063 T6
  - ✓ 6082 T6
- ✓ Plastic injection molding
- ✓ Vacuum casting
- ✓ 3D-printing aluminum
  - ✓ Stainless steel
- ✓ Aluminum
- ✓ Titanium
- ✗ 3D-printing plastics
- ✓ Surface finishing
  - ✓ Anodizing
  - ✓ Bead blasting
  - ✓ Sand blasting
  - ✓ Vapor polishing
- ✓ Surface coloring
  - ✓ Powder coating
  - ✓ Painting
  - ✓ Pad printing
  - ✓ Color matching
- ✓ Quality Inspection
  - ✓ Surfometer
  - ✓ Coordinate Measuring Machine
  - ✓ PolyMax Gun
  - ✓ Faro Laser Scanning
  - ✓ XRF Analyzer
  - ✓ Optical Emission Spectrometer (OES)



**Figure 3.8:** CNC

*Source: Exero Database [5]*



**Figure 3.9:** Metal 3D-printing,  
250x250x30 mm

*Source: Exero Database [5]*



**Figure 3.10:** Delivery floor

*Source: Exero Database [5]*



**Figure 3.11:** Quality control

*Source: Exero Database [5]*

The Star Rapid Prototyping facility consists of several storage buildings which hold a western factory standard. The workshops are clean and professional and are strategically placed in the different floors of the buildings. On deck they provide CNC-machining, EDM, metal 3D-printing, plastic injection molding, surface finish and color, see figures 3.8 and 3.9. The facility also provides a state of the art quality control on materials before and after processing, see figures 3.10 and 3.11.

**Table 3.2:** Die casting prices

<b>Die Casting Aluminum</b>	
<b>Shape</b>	<b>Price/cast</b>
Circular/Square	3000 RMB
Elliptical	4000 RMB
Custom	5000 RMB
Detailed	7000 RMB

Star Rapid Prototyping charges 1000 RMB for every die cast set-up. They can provide the following prices for die casting, see table 3.2.

Star Rapid Prototyping have a minimum of 1 unit per order. Gordon Styles, mechanical engineer, President and founder of Star Rapid, is very hands on with his customers. He wants Star Rapid Prototyping to be part of the prototyping phase. Price per unit will vary outside the following intervals; 1-5, 5-20, 20-50, 50-100, 100-500, 500-2000.

# 4

## Discussion

### 4.1 Product development theory

Product development and design methodologies consist of variety of processes. Some models are rigid with follow a strict path. Others are flexible with possibilities for subjective thinking. The current Spike™ is a beta prototype. It already satisfies the functionality requirements from the users. Further optimizing the design and finalizing the Spike™ for the market requires an flexible product development processes. The model must also be more focused on the later steps rather than the initial steps.

Flexible development counteracts the tendencies of many contemporary management approaches to plan a project. These include lean(MVP), which acts to drive out waste; and traditional project management and phased development systems(IPM & Stage-Gate), which encourage upfront planning and following the plan. Stage-Gate can be somewhat difficult for "messy" projects. It is not as iterative as other models. Completing an entire stage before moving through the next gate requires vast understanding of the product and market. Although these methodologies have strengths, they encourage rigidity in the process.

Developing a new design without losing any current features will require a flexible process. Set-Based Design requires more resources in the initial steps, but allows for an adaptive approach throughout the development. For a tangible product like the Spike™, prototyping and testing are important stages in verifying the technical solutions. The Spike™ is currently the third prototype of it's kind. According to Otto and Wood it would be classified as a beta or pre-production prototype. Buchenau and Suri's Experience Prototyping methods base the evolution of the prototype on user experience. In MVP, developers can deploy this product to a

potential user as an early adopter. The final, complete set of features is only designed and developed after considering feedback from the product's initial users. IDEO focuses on improving design ideas by making them physical, so users can interact with them.

## 4.2 Production and manufacturing

Ula Jern is a small manufacturer, but provides most of the necessary processes. They have connections with most factories and manufacturers in the Trondheim region. Ula Jern do not have access to die casting custom profiles and aluminum extrusion. That means this service must come from another extrusion manufacturer or the aluminum tubes must be of *standard profile*. Ula Jern do not handle plastics of any kind. Therefor plastic parts on the Spike™ will have to be 3D-printed, cast or CNC-machined by a third party manufacturer.

3a and Star Rapid Prototyping in Zhongshan, Guangdong share similar services. They have access to every necessary manufacturing process including die casting custom profile, extrusion and plastics. Star Rapid holds a higher standard and claim to have a 30% higher production price than there competitors, such as 3a Prototyping. 3a are a smaller company and are therefor easier to network with. There lower price is a crucial factor for Exero Technologies.

# 5

## Conclusion

The Spike™ is a functional prototype that has generated immense feedback for further development. Buchenau and Suri's Experience Prototyping methods are perfect for developing a market ready version of the Spike™. The product development model for the optimization of the Spike™ will follow a mixture of processes. For the initial and mid phases Set Based Design will provide a flexible development process for the Spike™. For the final stages of development Buchenau and Suri's experience prototyping methods, last stages of the IDEO model and MVP are perfect for prototyping and testing market ready version of the Spike™. In December 2017, the Spike™ prototype was sold to a paraplegic by the name of Espen Aksnes. The product was considered a Minimum Viable Product (MVP). Espen's feedback among other testers will be the basis for the new product requirements in the master thesis.

Ula Jern is a viable manufacturer for the first 5-20 units of the Spike™. They will be manufacturing the pre-production prototype with standard aluminum tubing. 3a Prototyping is a viable manufacturer for the final market ready version of the Spike™. Quotations will be evaluated throughout the master thesis.

The master thesis "Finalizing the Exero's Spike™ for production" will include:

- Design a pre-production prototype of the Spike™ with standard tubing. Establish a manufacturing deal with Ula Jern.
- Design the final, market ready version of the Spike™. Establish a manufacturing deal with 3a Prototyping.





# Bibliography

- [1] Minimum viable product: a guide. [http://cache.boston.com/multimedia/sports/bigshots/paralympics\\_2010/bs19.jpg](http://cache.boston.com/multimedia/sports/bigshots/paralympics_2010/bs19.jpg), 2009.
- [2] 2010 paralympics in vancouver. [https://gfx.nrk.no/akkH1F2DhnLyKMgBF5texQQEfFOLYjv-e-U01FrW\\_VFA](https://gfx.nrk.no/akkH1F2DhnLyKMgBF5texQQEfFOLYjv-e-U01FrW_VFA), 2010.
- [3] Johnsen Fon, Berg. Steering system for cross-country sit-skis, 2016.
- [4] Logo. <http://www.exerotech.com>, 2016.
- [5] Exero technologies database, 2017.
- [6] Oxford. Npd. <https://www.worldcat.org/title/dictionary-of-business-and-management/oclc/277068142>, 2009.
- [7] Kenneth B. Kahn. *The PDMA handbook of new product development*. John Wiley Sons Inc, 3th edition, 2012.
- [8] Moen Ron. A review of the ideo process. <https://www.rwjf.org/content/dam/web-assets/2001/10/a-review-of-the-ideo-process>, 2001.
- [9] Booz, allen and hamilton new product process. [http://samples.jbpub.com/9780763782610/82610\\_CH02\\_PASS02.pdf](http://samples.jbpub.com/9780763782610/82610_CH02_PASS02.pdf).
- [10] Robert G. Cooper. Stage-gate systems: A new tool for managing new products. [https://ac.els-cdn.com/000768139090040I/1-s2.0-000768139090040I-main.pdf?\\_tid=9ffa9ab8-dd91-11e7-80a9-00000aacb361&acdnt=1512900498\\_b2a9d956038d59c7be8804d1a64bc31f](https://ac.els-cdn.com/000768139090040I/1-s2.0-000768139090040I-main.pdf?_tid=9ffa9ab8-dd91-11e7-80a9-00000aacb361&acdnt=1512900498_b2a9d956038d59c7be8804d1a64bc31f), 1990.
- [11] Set-Based Design. Scaledagile. <http://www.scaledagileframework.com/set-based-design/>, urldate = 2017-11-14, 2017.
- [12] E. Blackwell, A. H.; Manar. *Prototype*. UXL Encyclopedia of Science, 3th edition, 2015.

- [13] C. W. Elverum. Advanced product development, 2017.
- [14] Eric Renner. Minimum viable product: a guide. <http://www.startuplessonslearned.com/2009/08/minimum-viable-product-guide.html>, 2009.
- [15] Logo. <https://ulajern.wordpress.com/>, 2014.
- [16] Guandong. [https://upload.wikimedia.org/wikipedia/commons/thumb/e/e3/Guangdong\\_in\\_China\\_%28%2Ball\\_claims\\_hatched%29.svg/1200px-Guangdong\\_in\\_China\\_%28%2Ball\\_claims\\_hatched%29.svg.png](https://upload.wikimedia.org/wikipedia/commons/thumb/e/e3/Guangdong_in_China_%28%2Ball_claims_hatched%29.svg/1200px-Guangdong_in_China_%28%2Ball_claims_hatched%29.svg.png), 2012.
- [17] Xihuan. [http://news.xinhuanet.com/english/2006-02/04/content\\_4133837.htm](http://news.xinhuanet.com/english/2006-02/04/content_4133837.htm), 2006.
- [18] Zhihu. <https://www.zhihu.com/>, 2017.
- [19] Logo. <http://www.3aprototype.com/index.html>, 2012.
- [20] Logo. <https://www.starrapid.com/>, 2012.

# A

## Meeting Reports

### A.1 Telephone meeting with Jessica Chen i 3a Prototyping 20.11.2017

<b>Meeting type</b> : Telephone call	
<b>Time, place</b> : 21.11.17	
<b>Present</b> : Andre Haig Johnsen, Exero Technologies Jessica Chen, 3a Prototyping	
Post	Case
1	<p><b>Meeting's purpose:</b></p> <ul style="list-style-type: none"> <li>- Request a visit to the factory.</li> <li>- 3a prototyping being a potential manufacturer in China when we our production quantity goes up.</li> <li>- Get friendly</li> </ul>
2	<p><b>Summary:</b></p> <ul style="list-style-type: none"> <li>- Jessica seems like a very kind and honest Chinese lady. There is no language barrier as she has very good English pronunciation. This makes communication very smooth.</li> <li>- Jessica would very much like for Exero to come visit. She said if we come on a weekday she can show us around the factory during working hours and we can discuss the prototype. Finally we can have lunch.</li> <li>- When our production quantity goes up in the future, Ula Jern will not be able to satisfy the need. Therefore, I asked 3A prototype about whether or not they can produce for us. We also discussed general production factories in Guandong and China and what we should expect. <ul style="list-style-type: none"> <li>- Our current make quantity would be at max 100 units. This is a remarkably low unit ask for factories in Guandong.</li> <li>- It all comes down to the product and the payoff, but most factories do not accept request unless there is more than 10 000 units, sometimes 100 000.</li> <li>- 3A prototyping themselves do not usually accept offers for under 100 units</li> <li>- Opened my eyes to what <b>networking</b> means in China. It is really all peer to peer contracts, rather than business to factory.</li> <li>- Jessica says that fex the only way an aluminium factory will extrude 100 of our main tubes or a welding factory will weld 100 of our truck plates, is because she is friends with the welding factory and extrusion factory owners.</li> </ul> </li> <li>- Conclusion: Producing less than 1000 units of any part on the Spike in Guandong is not possible without connections. To obtain such a service from a factory will require networking and getting friendly with someone within the factory. Therefor, I will travel to Guanzhao and meet with Jessica Chen.</li> </ul>
3	<p><b>Future work:</b></p> <p>Tickets to Guanzhao and what days. Thursday- Saturday maybe?</p>

## **A.2 Telephone meeting with Alex Jian Wu Innovation Norway Beijing 22.11.2017**

<b>Meeting type</b> : Telefon samtale	
<b>Time, place</b> : 22.11.17	
<b>Present</b> : Andre Haig Johnsen, Exero Technologies Alex Jian Wu/见无, Innovation Norway Beijing	
Post	Case
1	<p><b>Meetings purpose:</b></p> <ul style="list-style-type: none"> <li>- What are their services?</li> <li>- Can they set-up factory visits?</li> <li>- Can they suggest factories/manufacturers for us?</li> <li>- Get friendly</li> </ul>
2	<p><b>Summary:</b></p> <ul style="list-style-type: none"> <li>- They can give a pre revision of our situation.</li> <li>- Innovasjon Norge can provide 8 hours free service for general advisory service, but for this case, it will take longer time. Needs to know total budget</li> <li>- If we are only producing 100 or 200 units,we should use an agent instead of manufacturers and handle the export issues later.</li> <li>- They take 950 kr/h, but with support from Innovasjon Norge we only need to pay 550 kr/h out of our own pocket.</li> <li>- Molding costs 60 000 - 100 000 kr per piece depending on the complexity of the design.</li> <li>- Almost impossible to get a factory to produce less than 10 000 units.</li> <li>- Mentioned that many norwegian companies building products of metal that have low quantity production like us have resulted in using <b>3D metal printers</b>. This is the same price in Norway as in China.</li> </ul>
3	<p><b>Future work:</b> Waiting for a response on pre-revision.</p>

### **A.3 Meeting and factory visit StarRapid Prototyping 01.12.2017**

<b>Meeting type</b> : Product production meeting and factory tour	
<b>Time, place</b> : 16:00 PM - 19:00 PM 01.12.17, Zhongshan, Guangdong	
<b>Present</b> : Andre Haig Johnsen, Exero Technologies Hao Han, Exero Technologies business partner (translator) Huang "Alina" Chuanjun, Sales/Customer Service, StarRapid Prototyping Gordon Styles, President and Founder, StarRapid Prototyping	
<b>Post</b>	<b>Case</b>
1	<p><b>Meetings purpose:</b></p> <ul style="list-style-type: none"> <li>- Introductions/ meet and greet.</li> <li>- Discuss prototype and possible manufacturing solutions/quotations. Molding equipment.</li> <li>- Factory tour</li> </ul>
2	<p><b>Summary:</b></p> <p><b>Introduction:</b></p> <ul style="list-style-type: none"> <li>- I brought along Hao Han, my boss from Anne Inc. He served as a translator if needed and was presented to 3a Prototyping as a friend/business partner.</li> <li>- Factory is 15 min away from the center of Zhongshan.</li> <li>- At arrival I was met by Alina and a flat screen TV where it said "Greetings Andre Haig Johnsen, Exero Technologies".</li> </ul> <p><b>Factory tour:</b></p> <ul style="list-style-type: none"> <li>- I cannot understate how clean and professional this factory was. 260+ employees and they were all trained for one specific job. Multiple giant buildings, every floor had its purpose. Office space was huge with glass walls for openness. Everyone was very polite. The president took his time to great me and sat down to review the product. All though we are probably one of their least grossing customers, this fact did not seem to be present in their communication and excitement around our project.</li> <li>- They do CNC, EDM, Plastic die casting/molding, plastic injection molding, logo print on metal and plastic and vacuum casting. Plastic post work and packaging is down manually.</li> <li>- Welding, laser cutting, extrusion etc are all outsourced to other factories they have communications with. Obtaining communication with these extrusion factories would be near impossible for our low volume situation.</li> <li>- They have extensive quality control and tolerance control before and after handling the metals or plastics.</li> </ul> <p><b>Technical meeting:</b></p> <ul style="list-style-type: none"> <li>- StarRapid Prototyping advocates that they are a company for "low volume start ups". This is true as Gordon mentioned if we only want to order 1 unit, this is of course possible. He went on to say that price per unit will go be lower for intervals between 5-20, 20-50, 50-100. Thats means ordering 20 instead of 5 units won't lower the price per unit that much. The big difference in price per unit is of course when ordering 1000+ units.</li> </ul>



	<ul style="list-style-type: none"> <li>- Quotation for current Prototype 2.0 with circular tubing can not yet be determined as the BOM is not complete. (TBD)</li> <li>- Estimated manufacturing methods for parts: <ul style="list-style-type: none"> <li>- Truck plate; CNC or laser</li> <li>- Arms; CNC</li> <li>- Plastic seat diamond; Vacuum cast</li> <li>- Seat reinforcement;CNC</li> </ul> </li> <li>- Die casting, price/cast <ul style="list-style-type: none"> <li>- Circular 3000 RMB</li> <li>- Elliptical 4000-5000 RMB</li> <li>- Custom 5000 RMB</li> <li>- Very detailed 7000 RMB</li> <li>- Price for setting mold is 1000 RMB</li> </ul> </li> <li>- Recommends not having the cut-out, will be much cheaper.</li> <li>- Recommends vacuum cast for Plastic Seat diamond. This is much cheaper and just as strong.</li> </ul> <p><b>Final note::</b></p> <ul style="list-style-type: none"> <li>- Great hospitality. There is no language barrier whatsoever. The founder and many of the workers are british. The Chinese who work there are also very good at english.</li> <li>- Gordon, the president of the company seemed very down to earth. We had a great discussion and he seemed more like a curious engineer than the president of a multi million dollar company.</li> <li>- They consider themselves 30% more expensive than their competition due to their thoroughness and quality.</li> <li>- Definitely higher standard and quality than 3a prototyping.</li> <li>- Also I cannot forget to mention their mascot, Aiki, a seven year old golden retriever, see pics.</li> </ul>
3	<p><b>Future work:</b> BOM and get a quotation.</p>

## **A.4 Meeting and factory visit 3a Prototyping 01.12.2017**

# Meeting Report

<b>Meeting type</b>	: Product production meeting and factory tour
<b>Time, place</b>	10:00 AM - 16:00 PM 01.12.17, Zhongshan, Guangdong
<b>Present</b>	: Andre Haig Johnsen, Exero Technologies Hao Han, Exero Technologies business partner (translator) Jessica Chen, Sales/Customer Service, 3a Prototyping Fanny Fan, Sales/Customer Service, 3a Prototyping Technical worker (name unknown), 3a Prototyping
<b>Post</b>	<b>Case</b>
1	<p><b>Meetings purpose:</b></p> <ul style="list-style-type: none"> <li>- Introductions/ meet and greet.</li> <li>- Discuss prototype and possible manufacturing solutions/quotations. Molding equipment.</li> <li>- Factory tour</li> <li>- Lunch</li> </ul>
2	<p><b>Summary:</b></p> <p><b>Introduction:</b></p> <ul style="list-style-type: none"> <li>- I brought along Hao Han, my boss from Anne Inc. He served as a translator if needed and was presented to 3a Prototyping as a friend/business partner.</li> <li>- Got picked up at Guobi Hotel by Fanny Fan and her driver in a 2018 sudan.</li> <li>- Factory is 15 min away from the center of Zhongshan.</li> <li>- At arrival I was met by Jessica Chen, whom to my surprise was 3 months pregnant. First 1,5h of the meeting was not Exero related, but rather a friendly exchange of our personal lives.             <ul style="list-style-type: none"> <li>- Jessica has a 3 year old son. She is hoping for baby girl in March, but will not know until due-day. (This is because many traditionalists in China will have an abortion if they find out it's a girl). She used to work for Star Rapid, but is now much happier at 3a. (She also loves my hair)</li> <li>- Fanny has changed recently changed her name to "Franny". I didn't ask why. She is 23 years old and loves to talk. She is completely aware of the fact that she looks like she's 16 and thinks its funny.</li> </ul> </li> </ul> <p><b>Technical meeting:</b></p> <ul style="list-style-type: none"> <li>- Jessica saw no problem in ordering 10 units to begin with. The price difference due to the number of units are "ish" between 5-20, 20-50, 50-100. Thats means ordering 20 instead of 5 units won't lower the price per unit that much. The big difference in price per unit is of course when ordering 1000+ units.</li> <li>- Quotation for current Prototype 2.0 with circular tubing can not yet be determined as the BOM is not complete. (TBD)</li> <li>- Estimated prices and manufacturing methods for parts:             <ul style="list-style-type: none"> <li>- Truck plate; 150 RMB per plate, CNC or laser</li> <li>- Arms; 380 RMB per arm when buying 8 arms, CNC</li> <li>- Plastic seat diamond; 500 RMB per seat when buying 20 seats.</li> <li>- Seat reinforcement; unknown RMB, CNC and EDM</li> </ul> </li> </ul>

	<ul style="list-style-type: none"> <li>- Die casting, price/cast <ul style="list-style-type: none"> <li>- Circular/Square 3000 RMB</li> <li>- Elliptical 4000-5000 RMB</li> <li>- Custom 5000 RMB</li> <li>- Very detailed 7000 RMB</li> <li>- Price for setting mold is 800-1000 RMB</li> </ul> </li> <li>- Recommends not having the cut-out, will be much cheaper.</li> </ul> <p><b>Factory tour:</b></p> <ul style="list-style-type: none"> <li>- 3a Prototyping are currently expanding their factories and office space, see pictures on drive.</li> <li>- They do CNC, EDM and plastic die casting/molding. Plastic is their specialty. They have very good equipment in a rather dirty workplace. Plastic post work and packaging is down manually.</li> <li>- Welding, laser cutting, extrusion etc are all outsourced to other factories they have communications with. Obtaining communication with these extrusion factories would be near impossible for our low volume situation.</li> </ul> <p><b>Lunch and Museum:</b></p> <ul style="list-style-type: none"> <li>- at 13:00 PM Hao Han and I were treated to an amazing lunch consisting of pigeons and ducks. After lunch Fanny offered to take us to the most famous tourist attraction in Zhongshan, Sun Yat Sen's Residence Memorial Museum.</li> <li>- Finally, they drove us to StarRapid (competitor).</li> <li>- Great service and the kindest of people. There is no language barrier whatsoever. Jessica's english is as good as any norwegians and Fanny's right behind. Both Jessica and Fanny work in sales, but have more than enough knowledge about manufacturing equipment and process to be sufficient for communicating technically with Exero.</li> </ul>
3	<p><b>Future work:</b>  BOM and get a quotation.  Communication: Email, WeChat</p>

# B

**Bachelor Thesis; Steering system  
for cross-country sit-skis, 2016**