



NTNU – Trondheim
Norwegian University of
Science and Technology

Simulation and Analysis of a Wireless Sensor Network

Alejandro Matias Fabrello

Master of Science in Electronics

Submission date: July 2015

Supervisor: Snorre Aunet, IET

Norwegian University of Science and Technology
Department of Electronics and Telecommunications

Simulation and Analysis of a Wireless Sensor Network

Alejandro Fabrello

July 14,2015

To my family

Abstract

More efficient wireless communication in these days are a topic of capital importance. Specially in wireless sensor networks (WSN) where the system is often battery-powered.

In wireless Sensor Networks (WSN), where the number of nodes are relatively high, aspects such as communication throughput and lifetime become crucial. In order to design a system which fulfills the constraints imposed, it is important to have adequate tools to perform both design and simulation.

Narrow-band communication is proposed as a reasonable approach for this system, in view of the fact that such implementation will keep the system's design simple and inexpensive.

This thesis also proposes a method to characterize the system and prove the hypothesis about the use of the narrow-band communication instead of a spread spectrum approach. The use of a discrete event simulator to achieve the modeling of a communication system will prove its flexibility.

The results obtained throughout this thesis are optimistic about the use of a narrow-band communication that fulfills the specifications proposed. The simulations performed also give a good foundation for further investigation within the area.

Preface

This thesis was written during the spring of 2015 at the Norwegian University of Science and Technology, Department of Electronics and Telecommunications, in fulfillment of the requirements for obtaining the degree of Master of Science. The degree of Master of Science was carried out between fall of 2013 and spring of 2015, along with my full-time position at Siemens AS, where I have been working since 2011. The thesis was accomplished under the supervision of Prof. Snorre Aunet (NTNU) and with the cooperation of Anders Hagen (Q-Free) and Brage Blekken (Q-Free).

Acknowledgments

I would like to express my gratitude to the people who have supported me throughout the last years and those who in some way or another has helped me to accomplish this thesis. First of all I would like to thank my wife Ingrid for her unconditional support and understanding. Thank you for being beside me in this process, giving me strength. To my parents and siblings, who always have been there, supporting me in every possible way. To my coworkers at Siemens who have been very understanding during the these two years. To my friend Pablo who never stopped encouraging me to finish my master's degree. To the people at Q-free who made me feel at home during my time at the office. Special thanks to Anders and Brage who always kept their doors open for a chat. At last, but not least, to my advisor Prof. Snorre Aunet for his time and help making this work possible.

Alejandro M. Fabrello
Trondheim, July 2015

Contents

Abstract	i
Preface	iii
Acknowledgments	v
Contents	vi
List of Figures	ix
List of Tables	xi
I Introduction	1
1 Background and motivation	3
1.1 Introduction	3
1.1.1 IEEE 802.15.4	4
1.2 Context & Objectives	4
1.2.1 System Specifications	5
1.3 Scope	6
1.4 Thesis outline	6
II Theoretical Background	9
2 Theoretical Background	11
2.1 Aspects that will be simulated	11
2.1.1 Critical number of nodes	11
2.1.2 With or without acknowledgment	11
2.1.3 CSMA	12
2.1.4 Dynamic control of transmission power	12
2.1.5 Energy	12
3 Method	15

3.1	What criteria is used to choose a "good simulator"	15
3.1.1	Briefly simulator analysis	16
3.2	OMNeT++	17
3.2.1	Mixim as OmNet++'s framework	17
3.2.2	Models, networks and channels	18
3.2.3	Specific models used in this investigation	18
3.2.4	Application layer	19
3.2.5	Medium Access Control (MAC)	19
3.2.6	Physical layer	21

III Simulation 27

4 Simulation Testbeds 29

4.1	Carrier Sense Multiple Access	29
4.1.1	CSMA-CA	30
4.1.2	CSMA-CD	30
4.2	Attenuation	30
4.3	Near-Far problem	31
4.4	Maximum number of participants	32
4.5	Acknowledgment	33
4.6	Data Rate	33
4.7	Data Traffic	34

5 Results 35

5.1	Signal attenuation	36
5.2	Near-Far testbed	37
5.3	Maximum number of participants	38
5.4	Acknowledgment mechanism	42
5.5	Data Rate	43
5.6	Data Traffic	46

IV Conclusions 49

6 Discussion of the results 51

7 Conclusion 53

7.1	Future Work	53
-----	-----------------------	----

References	55
Appendix	57
Omnetpp.ini	59

List of Figures

3.1	Modeling concept	18
3.2	Physical Layer Graph	21
3.3	AirFram evaluation	22
3.4	Multidimensional Signal	23
4.1	Near-Far topology	31
5.1	Attenuation - lineal representation	36
5.2	Attenuation- logarithmic representation	36
5.3	RxTx Ratio	37
5.4	Backoffs	38
5.5	Rx/Tx Ratio	38
5.6	Missed Packets (normalized)	39
5.7	Missed Acknowledgments (normalized)	40
5.8	Backoffs	41
5.10	Dropped Frames	41
5.9	Latency time intervals	42
	(a) 100 Nodes	42
	(b) 300 Nodes	42
	(c) 600 Nodes	42
	(d) 1000 Nodes	42
5.11	Different parameters from a system with (<i>orange color</i>) and without (<i>blue color</i>) the use of an acknowledgment mechanism	43
	(a) Rx/Tx Ratio	43
	(b) Missed Packets	43
	(c) Backoffs	43
	(d) Dropped Frames	43
5.12	Latency time intervals	44
	(a) 1000 Nodes without acknowledgment	44
	(b) 1000 Nodes with acknowledgment	44
5.13	RxTx Ratio	45
5.14	Interference	45
5.15	Backoffs	46
5.16	RxTx Ratio	46

5.17 Interference	47
5.18 Backoffs	47
5.19 Missed Acknowledgments	48

List of Tables

3.1	Overview of simulation tools. Stehlik [2011]	17
-----	--	----

Part I
Introduction

Chapter 1

Background and motivation

1.1 Introduction

The study of wireless communication systems has become more and more important in the last years, since the amount of artifacts using this type of communication have been increasing as well as the conditions that these impose, like transmission's data rate, reliability, etc.

The medium access control (MAC) is a sublayer of the data link layer (DLL) in the OSI model. The MAC aims to handle the access to the shared channel and provides reliability, flow- and error-control. Ahmed and Khurram [2014]

Some of the challenges in the medium access in a wireless network are: i) it is very difficult to send and receive at the same time (full duplex) and ii) at the moment when the sender is trying to transmit a packet the sending node is not able to know the interference's situation at the receiver, where it really counts. This scenario makes collisions a common problem if it is not addressed correctly. This provokes that the sender sends a packet although a collision is imminent because the network is too complex to be sensed for the sender (hidden-node problem). With the utilization of a defined MAC it is desirable to achieve characteristic as high throughput, low overhead, low error rate, energy efficiency, etc.

When a energy efficient system is required it is important to find out which aspects have more incidence in the total energy consumption and to try to minimize them when it is possible. Some of them are inherent to the system's topology or technology chosen, and very little can be done with them, but others can be wisely reduced or even eliminated.

Collisions should be avoided since the packets that collide are wasted energy from nodes that have to send the packets again. Here it is important to define if the system's topology and its nature has the probability of collision which makes mandatory the use of a certain mechanism to eventually avoid or mitigate a collision. Such mechanism could for example be the use of a carrier sense, where the

node wanting to transmit, before it starts, listens to the channel and controls the channel's availability. This mechanism is not always optimal because problems such as hidden- and exposed-nodes can occur. The use of a RTS/CTS mechanism is a better way to avoid collisions, but the overhead becomes significant.

To find a MAC that works for the network in question is a task that demands some kind of knowledge about the nature of the system, and how the characteristic of the MAC affect the performance of the network in general. It is possible that when trying to avoid collisions some overhead will be incurred in the system.

1.1.1 IEEE 802.15.4

IEEE 802.15.4 is an standard for low rate applications used when moderate delays are accepted and low consumption is desired. This protocol will be used in all the simulations carry out in this thesis.Chen and Dressler [2007]

The physical layer is one of the most important part of the simulation and will be treated later in the section 3.2.6, where a functional description of the whole layer will be provided. The medium access control (MAC) layer is important as well and aims the main management of the access right to the wireless channel. MAC layer is discussed in depth in section 3.2.5.

1.2 Context & Objectives

This thesis project was carried through in collaboration with the development department of Q-free. The objectives of the thesis are to find a tools capable of carry out simulation of Wireless Sensor Networks (WSN), to then characterize a Wireless Sensor Network - narrow-band communication and determine how different configurations and parameters affect the efficiency and throughput of the network. Along with the objectives previously named it is desirable to find the network's characteristics which will minimize a critical issue such as the power consumption of the sensors. In addition the system should be kept as inexpensive as possible. To find critical parameters in the network, such as the maximum number of sensors that the network is capable of managing, the maximum transmission's data rate, max. distance and battery lifetime is a main concern. In an attempt to characterize the system that maximizes its performance, a simulation tool will be used. Such an implementation will provide the necessary flexibility and ductility to carry out the simulations in an effective way.

In order to find the simulation tool that will be used during this investigation, the following three steps will be follow

1. **Development/study of appropriate frameworks/models.**

In order to study the system in question, it is necessary to find tools capable of simulating a wireless sensor network that corresponds with the system's specifications and fits the grade of abstraction necessary to obtain useful

results without unnecessary complexity. During the tests that will be carried through in this project it is preferable to use models that has been designed under an object-oriented and hierarchical premise. In this way, the final system becomes scalable and more robust.

2. **Implementation of the models in a network simulation.**

Before the implementation work can start, it is necessary to define the framework that will be used. This framework will act as a main guideline for the models necessary in the simulation.

3. **Realization of testbeds.**

In order to obtain the data necessary, a group of testbeds will be simulated. The scenarios evaluated will be chosen in order to highlight the consequences that certain parameters can have over the total performance of the system.

1.2.1 System Specifications

The system that will be analyzed in this thesis is a wireless sensor network (WSN) consisting of several low-cost nodes and one base station. The communication only goes between the nodes and the base station, defining a star-topology. Traffic in both ways can be considered if an acknowledgment mechanism is relevant for the application. The nodes are battery-powered, so energy efficiency will be of concern, this not apply for the base station, which it expected to have no constraints about the power consumption. The wireless sensor network will be designed to run on a parking lot, where each parking space will have a sensor node that transmit to the base station every time a car drives in or out of the parking space. The sensor will be placed at the ground level, so attenuations when a car parked over the sensor should be expected.

- *Transmission power:* The maximum allow power is 1 mW or 0 dBm.
- *Number of nodes:* The network should be able to manage up to 1000 nodes.
- *Carrier frequency:* The system will operate at a frequency of 900 Mhz.
- *Traffic:* The frequency at which the events occurs in each parking space is relatively low.
- *Packet size:* The information to be transmit from the sensor node to the base station is in principle small. But a size of 10 bytes should be expected in order to include a serial number, status and CRC.
- *transimission range:* The nodes should be able to communicate from a distance of 500 - 1000 meters to the base station.

1.3 Scope

The scope of the thesis includes the analysis of a narrow-band communication in a wireless sensor network. The system analyzed should be able to comply with the specifications listed in section 1.2.1. Some of the phenomena that occurs in a real wireless channel has not been taken into account (modeled) because they are not relevant for the analysis, includes an unnecessary overhead to the simulation or its modeling is too complex to be represented. For practical reasons, in this investigation, the characteristics in the wireless channel will be presume constants during the transmission of a packet.

1.4 Thesis outline

This thesis is divided into four parts: **Part I: Introduction** consists in an introductory review where the reader will get an idea about the motivation of this work and its scope; **Part II: Theoretical Background** presents the previous works and the theoretical background used throughout this thesis, as well as the methodology used during this work; **Part III: Simulation** includes a description of the testbeds implemented along with the results obtained; **Part IV: Conclusions** presents the discussion of the results, final conclusions and future work.

Introduction

Chapter 1: Background and motivation. This chapter starts with a general background on wireless communication in a wireless sensor network and the importance of an efficient architecture in order to achieve low power consumption. This chapter will also present a brief context of this thesis as well as its motivation and scope.

Theoretical Background

Chapter 2: Theoretical Background. In this chapter wireless concepts are addressed in depth, and a basic parametrization of the network is also presented. These will lead to the definition of the testbeds.

Chapter 3: Method. This chapter introduces the methodology chosen to carry on the investigation, and also the aspects that have been important during the selection process of the best simulation tool according to the specifications of the system.

Simulation

Chapter 4: Simulation Testbeds. This chapter contains a detailed description of the simulations that have been carried out during this investigation. Every description also contains a full enumeration of all the parameters that are relevant for the simulation.

Chapter 5: Results. The data issued from the different simulations will be presented here. Some comments will be included as well.

Conclusions

Chapter 6: Discussion of the results. A more detailed discussion about the results obtained from the simulations and how the different testbeds are related will be made in this chapter.

Chapter 7: Conclusion. This chapter provides the final conclusion of this thesis and presents opportunities for future work.

Part II

Theoretical Background

Chapter 2

Theoretical Background

2.1 Aspects that will be simulated

Basically, the consequences from variations in the parameters that conforms the MAC and physical layer will be tested. Aspects of major concern are:

2.1.1 Critical number of nodes

In this test a simulation is carried out in order to estimate the limits of the system. Factors such as the use of acknowledgments, carry sense, the amount of traffic and data rate, are all crucial when determining the maximum number of nodes in the network.

In this simulation a clear result is expected, one which will visualize at which point during the nodes incrementation the performance of the network starts decaying significantly.

2.1.2 With or without acknowledgment

This testbed evaluates the consequences of the acknowledgment's inclusion/exclusion in the communication between the nodes (sensors) and the base station. If an acknowledgment is required by the sensor to confirm the right reception of the messages on the base station, then it is necessary to take into account that it will produce both positive and negative results in the total performance. On one hand the use of acknowledgments gives a solid mechanism to ensure to some point the message delivering, because if the sensor node does not receive the acknowledgment after a certain time determined by the nature of the network topology, a retransmission can take place, giving the message a new opportunity to reach the base station.

If an acknowledgment mechanism is not implemented, then we can not assure that the message has reached its destination, the base station. At this point

two options arise, one alternative is to assume the low probability of the event (that the message does not reach the base station) and therefore just accept a certain degree of error in the system. The other alternative is conclude that the probability of consecutive error in message transmission is low enough for the system to send two copies of the same message with certain interval of time between them. This technique does not assure the correct reception of the message, but bases its functionality on the fact that an error is not probable. In addition an overhead will be inserted in the base station which will handle double amount of messages and make the evaluation in order to discards the duplicated ones.

2.1.3 CSMA

One of the other major points to be tested in this investigation is the use of a carry sense mechanism. A lot of papers in the last years have presented different solution to energy-efficient networks using carry sense in order to avoid, or at least detect collisions. Carrier sense Multiple Access (CSMA) is a mechanism where the node listens to the channel in order to determine if there is another communication in process, namely that the channel is occupied for another user. If so, then the node waits for a certain period of time before it tries again. But CSMA has some problems, specially in big topologies where the sensor transmitting is not able to sense the whole network. So although the channel is not free, the node sensing is not able to detect it and it will transmit, most probably producing a collision. Kredo and Mohapatra [2007]

2.1.4 Dynamic control of transmission power

It is desirable to evaluate how critical the near-far problem is in this system in order to be able to make a decision about the use of a dynamic power control during the transmission. In principle, such mechanism is not preferred and should only be used when it is totally necessary, because it leads to more complexity in the system and implies that the lifetime of the battery is no longer equal for all the nodes. The nodes transmitting with more power will have a battery with a lifetime shorter than the others.

2.1.5 Energy

The energy issue is basically determined in every single decision made in the design of the system. For example if the nodes have to wait for an acknowledgment from the base station before they can go to sleep, this means more power consumption, more time where the sensor node has to be awake and less lifetime for the battery. The same happens with the use of a CSMA mechanism in the network. The fact that every sensor has to listen to the channel before it start to send, implies more power consumption.

So why should such mechanism be considered at all if one of the main goals is the minimization of the power consumption? Well, part of this investigation is to determine by means of simulation and analysis when and under which conditions such mechanisms are necessary. To do this it is important to map out the nature of the system, and to determine the probability of a collision. If such event is improbable to such a degree that it can be considered virtually impossible, then it is not longer necessary to implement a mechanism that prevents a situation that was highly improbable from the start.

Chapter 3

Method

In the study of wireless sensor networks which has a appreciable number of participants it is of crucial importance to find an efficient way to make simulations. During the early development phase it can be unpractical and expensive to test with real hardware. In addition, the cost/time consumption related to the fabrication of the system can become prohibitive. The market demands products that go from prototyping to manufacturing in a short amount of time.

For this reason, in this thesis a simulation tool was chosen in order to estimate the behavior of the system, and to explore the consequences that different parameters could produce in the network characteristics. Such parameters are scalability, throughput and lifetime.

3.1 What criteria is used to choose a "good simulator"

In the selection process several simulation tools were taken into consideration and evaluated according to different aspects. These aspects do not pretend to be a general and rigorous list, but an enumeration of the factors that could be relevant, if one takes the system's specification and its nature into consideration.

1. **flexibility:**

In order to have an adaptability that permits the system to adapt to different scenarios, it is necessary for the models contained in the simulator to be modifiable. One desired feature is for the system to operate with different levels of abstraction, making it possible to simulate the system with different levels of details without incurring into unnecessary overhead. Flexibility can be achieve in different ways, but some key concepts that should be considered are: object-oriented models, open-source platform and hierarchical topologies.

The simulations scenario programmed should be easily scalable in order to be able to reuse previous work or to simulate growing effects in the network. For this particular investigation the simulation tools have to be capable of handling large-scale networks with at least 1000 nodes.

2. **easy to program:** The simulator should be programmable by a well spread programming language, making it easier to reuse knowledge from before and minimizing the time necessary to start using the tool. The use of a well-known programming language also means a larger and stronger community support and a generally more robust product.
3. **fidelity:** The results obtained from the simulator should be at least as accurate as necessary in order to get useful data from the testbeds. It should also be possible to validate the simulation results obtained since it is of primary importance that the data issued is credible and accurate.
4. **documentation:** To have access to documents as manuals, papers and technical notes can improve the final results of the investigation, reducing engineering time and increasing the robustness as well. Another factor closely related to the documentation is the size of the community that uses the simulation tool. It is presumable that tools with bigger user communities deliver a product with better performance than a tool with just a few users.
5. **commercial/free:** Although this is not a crucial aspect in the selection, it is important to know the pros and cons of both options. A commercial version usually supplies a better tech. support, based on the fact that the user is paying for the service. On the other hand, if the commercial product has relatively few user, the program usually contains more unsolved issues (bugs) than a free simulation tool with thousands of users.
6. **Other aspects:** A energy-consumption capability is not a primary concern during the selection process of the simulation tool, because this calculation could be roughly made by other means without affecting the results. However, it will always be preferable to have the energy consumption capability in the same tool when possible. That is, giving the possibility of an easy cross-referencing between the energy data and other parameters of the network.

3.1.1 Briefly simulator analysis

As mention in Stehlik [2011], there are a wide range of simulators capable of simulate processes related to a wireless sensor network. They all have their strengths and weaknesses, so the most important decision to make it is to define which are the expectations about the simulator and which features that could be leave aside in the case the simulator does not provide it.

The evaluation of the different candidates was based on the criteria described in the section 3.1, details provided in Stehlik [2011] and the author’s own experience testing the tools. Boulis [Boulis] The table 3.1 presents an overview of the simulation tools considered in this thesis.

OmNET++ combined with Mixim framework was chosen to be the simulation tool in this investigation.

Table 3.1: Overview of simulation tools. Stehlik [2011]

Name	Language	Energy consumption capability	Graphical interface	Comments
NS-2	C++, Tcl	yes	yes	Very popular simulator
OmNET++ (Mixim)	C++, NED	yes	yes	MiXim is a framework, design for WSN simulation.
OmNET++ (Castalia)	C++, NED	yes	yes	Castalia is another extension for OmNET as well.
OPNET	C	yes	yes	Commercial version of OmNET++.
TOSSIM	C++, Python	no	yes	Embedded in TinyOS operating system.

3.2 OMNeT++

OMNeT++¹ is an object-oriented discrete event simulation tool, based on C++ classes. It is not limited to the analysis of wireless sensor networks, which makes its use possible in many other areas. OMNeT++ acts as a simulation engine, providing the tools needed in order to write own models and run simulations. Its object-oriented nature makes the simulation process effective and intuitive. Models from the different libraries can be combined and reused in order to obtain the desired topology. This is the case with Castalia and Mixim, two libraries or frameworks that contains models specially design for the simulation of wireless channel. More complex models can be created by means of simple ones, providing a clear and structured entity. Once the models intended to be used under the simulation have been defined and programmed, a testbed program, specifying the behavior that the models will have during the simulation should be written. There is an advantage in the fact that models and testbeds remains independent. The simulation of a network defined by a group of models can be tested under several scenarios, just by changing the testbed and keeping the model unchanged. Varga [2014]

3.2.1 Mixim as OmNet++’s framework

As mention before Mixim² will provide the framework and models necessary to simulate the wireless sensor network of this investigation. Mixim was able to fulfill

¹<https://omnetpp.org/>

²<http://mixim.sourceforge.net/>

the requirements needed in this investigation, and at the same time shows great potential for future development. Another interesting point along the features that Mixim has was the capability of multidimensional definition of a signal. This feature is not used in this investigation, its use is proposed in the future work section at the end of this thesis. Koepke et al. [2008]

3.2.2 Models, networks and channels

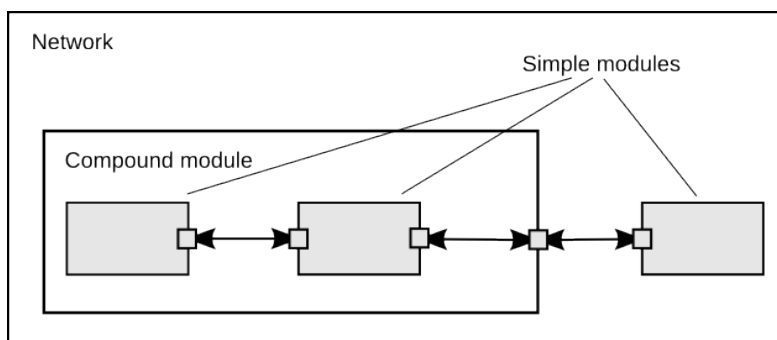

Figure 3.1: Modeling concept

As shown in figure 3.1, the *Network* is the entity in OmNet++ that aims to contain all the modules included in the system.

A diagram with the concept of models used in OMNeT++ is presented in figure Fig. 3.1. Here the boxes with gray background represents simple modules, while the compound ones are represented with white background. The communication between modules is accomplished by means of message passing.

Channels are basically a module specifically designed to serve as communication links between two other modules. The wireless channel is modeled is this way.

3.2.3 Specific models used in this investigation

The basic representation of a wireless node used throughout this work was defined using different modules and submodules from the Mixim framework. The node is based on a standard OSI-layer architecture, where just the application, network and physical layers are present. The other layer has been excluded because the nature of the system investigated does not require such complexity. A submodule to handle the power consumption of the node is also included in the topology of the node. This submodule will report every event that is relevant to the power consumption of the battery. Another submodule included in the node is the mobility submodule, which aims to simulate movements in the nodes during simulation time. At the moment being both the battery and the mobility submodule are not in use, but their inclusion do not represent a significant overhead in the system, so it will be kept in case of future necessity.

3.2.4 Application layer

The main purpose of this layer is to provide data traffic simulation in every node. This is generated by a mathematical model that simulates physical changes in the environment which would trigger the sensor in the real node. In this specific thesis these physical changes represents a car driving in and out of a parking lot.

In this project the frequency of these events have been defined by a uniform distribution that obeys the following formula

$$f(x) = \begin{cases} \frac{1}{b-a} & : a \leq x \leq b \\ 0 & : otherwise \end{cases} \quad (3.1)$$

The value issued from this formula represents a probability and the parameters a and b have been set to 0 and 30 respectively. In the simulation, this can be interpreted as every parking lot changing its state at least every 30 minutes. This is in practice a quite pessimistic prediction, but at the same time gives the results a safe margin. If no other information is specified in the testbeds, the application layer generates a fix number of events, set for now to 48 events in each node. Consequently the simulation-time would not exceed 24 hours. The wall-clock time will be dependent of the level of abstraction use, number of data stored and total number of events registered.

Message length:

The essence of the system is basically, and in a first instance to inform a base station of the presence or absence of a car in a parking lot. In this particular case the information transmitted is just one bit. However, additional data is necessary in order to identify the sender, provide error detection and an eventual correction. For this reason the length of the packet has been set to 15 bytes, a value that exceeds the specification, but that again gives the results a certain margin of safety. With a shorter packet the time the message spends in the wireless channel will be decreased and consequently the probability of a collision with other packets will decrease as well.

3.2.5 Medium Access Control (MAC)

The MAC layer has a capital importance for the angle this investigation will use for the analysis. As mentioned before, the MAC is responsible for the granting process in which every node gets access to the shared resource during a period of time. The shared resource is in this case the wireless channel. There are several different approaches, some of them better suited than others, depending on the application in question. But in general they all try to achieve low-energy consumption and high throughput. In this thesis the node used has a Carrier Sense Multiple Access

as a MAC. The main feature of this approach is a wireless channel which is sensed previous to the transmission start. This allows the node to evaluate if a collision is imminent. If the channel appears to be occupied by another node, then a back-off mechanism is started in order to wait until the next try, if applicable. This MAC allows the use of an acknowledgment mechanism if desirable, so during the simulation both conditions will be tested. Abed [2012]. Nguyen et al. [2014]

Transmission rate:

The transmission rate is specified inside the MAC module by a parameter and its value together with the packet's size has direct implications on the time a transmission will last in the wireless channel. Other parameters such as the radio sensibility will have a direct relation with the transmission rate parameter. In the case of a protocol with acknowledgment mechanism, it is also necessary to tune the time the sender will wait for an acknowledge arrival depending on the transmission rate used. The value used for the transmission rate in this case is by default 40 kbps, but in some testbeds this value is used as simulation parameter and changed in order to observe the implication in the total performance of the network. According to the data-sheet of the radio chosen to be simulated a transmission rate of 40 kbps gives a radio sensibility of -120 dBm.

Transmission Power:

These parameters specify the amount of power the signal will be transmitted with. This value is attached to every packet that sends from a node. The information about the transmission power is read by the receptor. Then the receiving node use the power information as a starting point to apply the different attenuations that a signal might have experimented during its journey from the sender to the receiver. More about how the attenuations are handled will be presented in the section 3.2.6 about signal modeling.

Acknowledge Mechanism:

The CSMA provides the feature where a packet can be sent to the original sender as a confirmation (acknowledgment) that the packet has been received in good conditions, and that no further actions are necessary. In the case that the sender does not receive the confirmation within a certain period of time defined by a parameter, the sender will issue a retransmission of the packet. The use of acknowledgment, the period of time waited until the retransmission, the time that the node waits between it knows that a retransmission will take place until it happens and finally, the number of retransmission can all be parametrized in the testbeds.

Here are the values used by default, in some simulations. Some of them are modified in order to appreciate the consequences of such changes in the perfor-

mance of the network.

- `**nic.mac.TxPower = 1 mW`
- `**nic.mac.BitRate = 40 kbps`
- `**nic.mac.MaxBackOffs = 5` (max. tries when the channel is busy)
- `**nic.mac.MaxFrameRetries = 3` (max. tries after a missed ack.)
- `**nic.mac.AckWaitDuration = 3.5 ms` (Period of time until a ack. is declared missed) As mentioned before this value is closely related to the bit rate and the message length.
- `**nic.mac.UseMACAcks = True/False` (Both are use in different simulations)

3.2.6 Physical layer

This layer is as well as the MAC, one of the most important pieces in the model. As its name explains, in this layer all the processes related the physical part of the system occur. It is convenient to start defining the main blocks of this layer and which function every block has. A detailed description of the main blocks of this layer is depicted in the figure 3.2. Wessel et al. [2009]

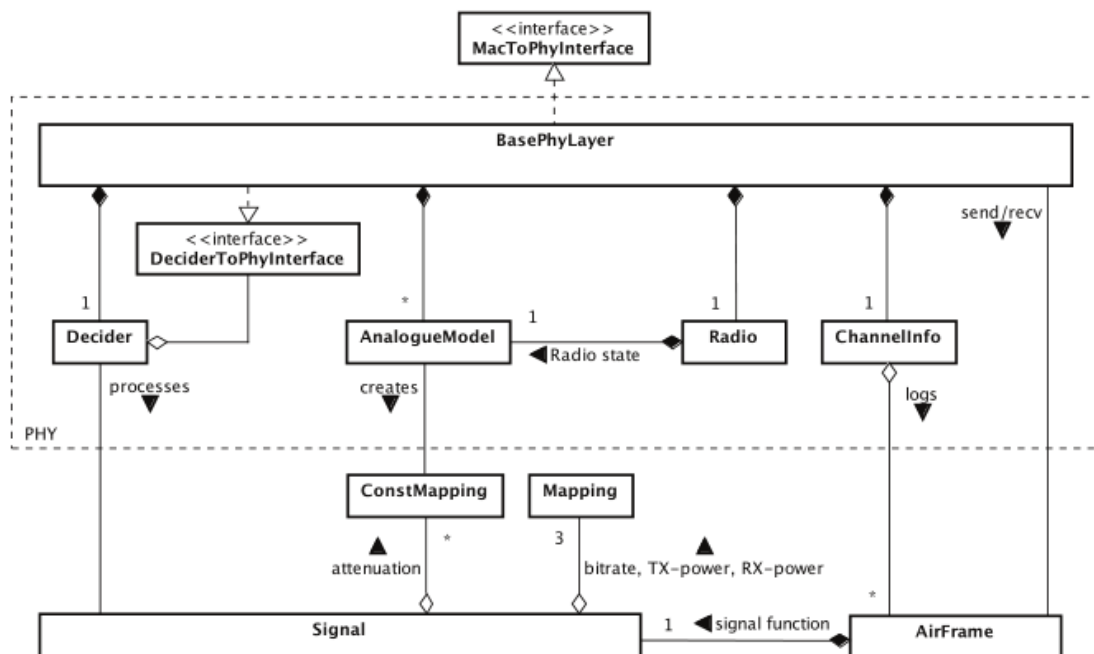

Figure 3.2: PhyLayerGraph

Air Frame

The Air Frame contains all the data transferred from the sender to the receiver. In addition to the proper Signal, the Air Frame contains other important parameters for the receiver such as the type of Air Frame (normal/Control) and duration.

Channel Info

The function of the `Channel Info` is to keep track of all the air frames on the channel. A vector of `Signals` intercepting a given time interval can be returned when necessary. This vector is used to calculate interference between a given signal that has been in the channel for a given period of time, and all the other signals that totally or partially intercepts this time period. The figure 3.3 shows how the air frames are registered in the `Channel Info` and then evaluated for interference.

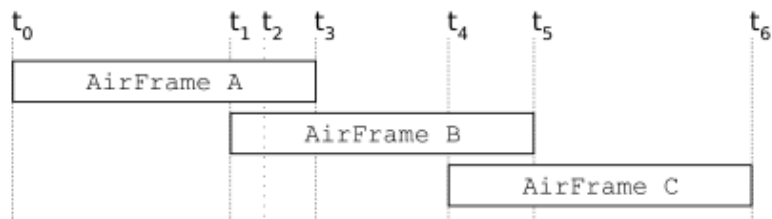

Figure 3.3: AirFram evaluation

In the figure 3.3 the air frame A will become inactive in t_3 , but it will not be deleted until t_5 when the other frame (air frame B) which is intersecting has become inactive. Wessel et al. [2009]

Signal

The signal is an entity contained inside the Air Frame and it models the physical data transmitted through the wireless channel. In its most simple form it contains information about the transmission power, also called TX-power. Signal class has also multi-dimensional support that enables the programmer to define the signal in several dimensions (up to ten dimension in addition to the time-dimension). The figure 3.4 shows how the different dimension are connected each other. In this example, frequency, space and time are the three dimensions. Swigulski [2007]

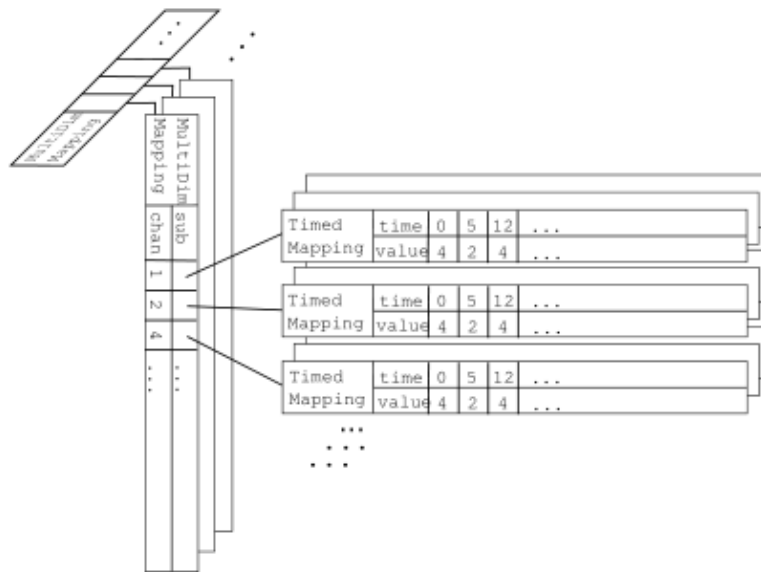

Figure 3.4: Multidimensional Signal

Analog Model

The **Analog Model** acts basically as a filter that runs over the signal obtained from the **Air Frame** that the node received. This signal is initially unchanged when it arrives to the receiver, so it has to run through the Analog Model in order to apply all the simulated attenuations. In this thesis the analog model used is called **SimplePathloss**.

Decider

The Decider has as its main responsibility to decide if the packet received is a signal or noise. In the case of it being interpreted as a signal, the Decider will evaluate the signal's correctness taking into consideration the signal and its interfering noise. This consideration is made by calculating the signal-noise ratio (SNR). The SNR is based on the vector of Signals the Decider asks from the **Channel Info**. In this thesis a decider called **Decider802154Narrow** is used, this module is designed to work with a 802.15.4 protocol in a narrow band system. The decider can evaluate the received signal several times if required. If a new message arrives while another packet is being processed, the new message will be automatically discarded and it will also count as interference to the message that was already there. Wessel et al. [2009]

The equation 3.2 calculates the value of the Bit Error Ratio (BER), based on

the SNR, which, as explain above, has been obtained from the `Channel Info`. This formula corresponds with a communication that uses Minimum Shift Keying (MSK) modulation. ERFC is the complementary error function and its definition is expressed by the equation 3.3.

$$BER = \frac{1}{2}ERFC(\sqrt{SNR}) \quad (3.2)$$

$$ERFC = \frac{2}{\sqrt{\pi}} \int_x^{\infty} e^{-t^2} dt \quad (3.3)$$

Once the BER has been calculated, an `Error probability` which depends on the BER and the numbers of bits evaluated is obtain by the formula 3.4

$$ErrorProbability = 1 - (1 - BER)^{n_{bits}} \quad (3.4)$$

In the last step, the `Error probability` is compared with the result of a uniform distribution (eq.3.5), if it is false, then an error in the communication has been simulated.

$$ErrorProbability < uniform(0,1) \quad (3.5)$$

Relevant parameters in the physical layer

- `phy.sensibility = -90 dBm` this value differs from the value mentioned in 3.2.5, the reason is that the sensibility value has been decreased in an attempt to consider the attenuations in both antennas and also the attenuation the signal suffers traveling from under the car until it reaches open air.

The following two parameters represent how the radio state (RX - TX - SLEEP) in the moment of the reception affects (attenuates) the receiving signal.

- `phy.radioMinAtt = 1.0` represents the signal attenuation when the radio is in RX-mode. the value has no unit. Therefore, 1.0 represents a unchanged signal and 0.0 total attenuation.
- `phy.radioMaxAtt = 1.0` is applied whenever the radio is not in RX-mode.
- `phy.useThermalNoise = True`
- `phy.thermalNoise = -110 dBm` indicates the intensity of the background noise considered. This parameter only applies when `phy.useThermalNoise` is set to true.

- `phy.usePropagationDelay = true` ;indicate that the simulation takes into consideration the time the packet uses to arrive to the receiving node.

Part III

Simulation

Chapter 4

Simulation Testbeds

This chapter starts with a short introduction about its division into different sections. Every section in this chapter will treat a specific testbed or scenario. In addition to the description of the simulation in question, relevant parameters will be commented and discussed. Every testbed will simulate the system while one specific parameter varies. As the test moves forward, some of the testbeds will use results from previous simulations. This will be indicated in the corresponding testbed if applicable. All the testbeds take as their starting point the same models, this means that as long as nothing else is specified in the simulation, the nodes will have the same properties.

One important comment about the results issued from the testbed is that OmNet++ and Mixim provide results that are totally capable of replication, which means that even though the simulation contains stochastic processes, as long as nothing else is specified, the simulator engine will use the same random seed in order to provide the same results. When it is desirable to run the same simulation with different random seeds, it has to be parametrized. After the simulation is run, the results can be analyzed separately or as an average.

4.1 Carrier Sense Multiple Access

Carrier sense is a medium access control (MAC) method used to manage the access to the communication channel as a shared resource. A carrier sense method can help to avoid an imminent collision, but in complex and large networks it becomes more difficult because of the hidden-node problem. This means that in large networks the node sensing the channel is not able to hear beyond a defined range, which can be smaller than the total size of the network, leaving other nodes outside. These nodes are called hidden-nodes. There are two variations of pure CSMA.

4.1.1 CSMA-CA

CSMA/CA: collision avoidance, use RTS and CTS to minimize the problem with the hidden-nodes. One disadvantage with this technique is that the RTS/CTS includes an important overhead for small package transmissions.

4.1.2 CSMA-CD

CSMA/CD: collision detection, where the transmission is interrupted as soon as a collision is detected in order to shorten down the time required until a retry can be performed.

All the testbeds in this work will be carried out using models that has implemented a CSMA method as medium access control.

4.2 Attenuation

The first testbed aims to obtain a graphical representation over the attenuation the signal suffers during the transmission from the sender to the receiver. With this curve and the radio specification about its sensibility and transmission rate, it is possible to sketch the maximum distance from which a node can be successfully transmitting to its base station. Without loss of precision the attenuation will be presumed to be constant during the packet's time period. The attenuation is calculated in the physical layer in the receiver node, more precisely in the Analog Model. For this investigation the attenuation has been modeled by the so-called `SimpalePathlossModel` that obeys the following formula:

$$PathLoss = \left(\frac{4\pi d^{\frac{\alpha}{2}}}{\lambda} \right)^2 \quad (4.1)$$

As we can see in equation 4.1 the attenuation depends on the distance (d) expressed in meters, the wave length (λ) also expressed in meters and the path loss factor (α) used when the environment can not be assumed to be free space. The latter can be changed using the parameter `*.connectionManager.alpha`. In this testbed two different values of α has been used, but in the future testbeds a free space scenario ($\alpha = 2.0$) will be assumed.

For this testbed a node was programmed to send packets from different positions in the environment, each one with a predefined distance between the node and its base station. The signal strength obtained after every sending was recorded. In some situations the path loss is better expressed in dB. Here is the path loss formula expressed in dB:

$$PathLoss_{dB} = 20 \left(\frac{\alpha}{2} \right) \log(d) + 20 \log(f) - 147.55 \quad (4.2)$$

4.3 Near-Far problem

As mentioned earlier the Near-Far problem occurs when a base station receives two different packets at the same time; one from a node situated in the proximity and the other one placed in the vicinity of the maximal allowed distance (established in the previous test 4.2). If the transmission power is initially the same for both nodes, the base station will sense a significant difference between both signal strengths. This situation can lead to problems for the nodes transmitting from far way, since the signal from those nodes can be shadowed for the transmissions from the nodes situated in the vicinity of the base station.

It is possible to take some actions in order to avoid or minimize these problems. But, since such actions can lead to other kinds of inconveniences, it is desirable to investigate to which grade the problem impacts this wireless sensor network in particular.

One reason to think that the Near-Far problem can be assumed irrelevant for this system resides in the nature and dynamic of the network in question. Two important characteristics that support this are: i) The communication packets are relatively small in size, 15 bytes. This combined with a transmission rate of up to 40 kbps, gives a transit time of around 3.2 ms. ii) the events that trigger a sending in each node occurs with a relative low frequency. The combination of these two factors give a very low probability of a collision between a "near-node" and a "far-node".

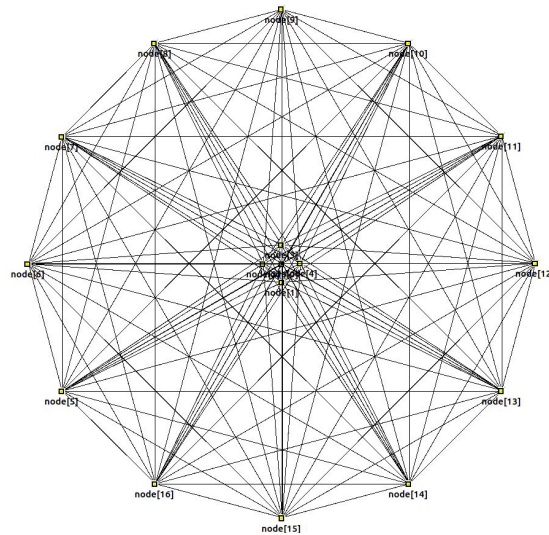

Figure 4.1: Near-Far Topology

With this theory in mind, this testbed will reproduce the situation described before. As is shown in the figure 4.1 an arrangement has been made where 12 nodes (from node 5 to 16) were placed on a circle with radius equal to the maximum

possible distance, then 4 nodes (from node 1 to 4) were placed in a concentric circle with a 50 meters radius, and finally a base station (node 0) was placed in the center of both circles. During the simulation the nodes situated in the inner circle will transmit packets twice as often as the nodes situated in the outer circle, in an attempt to stress the wireless channel and induce a scenario where collisions can be more feasible. The results issued from this testbed will help to find out if there is a correlation between the number of sent packets and lost ones for the nodes placed in the outer circle.

One relevant part of the simulation here is to evaluate more in detail the fairness of the Decider inside the Physical Layer.

The relevant parameters used in this testbed are enumerated as follow

- `**node[0].appl.nbPackets = 0` the base station does not transmit normal packets, just receive from the other nodes and eventually responds with an acknowledgment.
- `**node[5..16].appl.trafficParam = 1min` is the parameter that used in the uniform distribution formula. Applies to nodes 5 to 16 (outer circle).
- `**node[1..4].appl.trafficParam = 1s` is the parameter that used in the uniform distribution formula. Applies to nodes 1 to 4 (inner circle).
- `**node[5..16].appl.nbPackets = 48` is the number of packets that will be transmitted from each node during the simulation. Applies to node 5 to 16 (outer circle).
- `**node[1..4].appl.nbPackets = 2880` is the number of packets that will be transmitted from each node during the simulation. Applies to node 1 to 4 (inner circle).
- `**nic.mac.useMACAcks = true/false` The simulation is carry out with both with and without acknowledgment mechanism.

4.4 Maximum number of participants

The number of participants in a network will influence how the whole system performs. It is expected that as the wireless sensor network grows in number of participants, the probability for a packet collision grows as well. It is also expected that the duty cycle of the wireless channel will increase because of the increasing traffic. Consequently the numbers of back-offs each node has to make before they can start transmitting will also increase, as well as the latency.

The system's specification given initially sets the number of nodes to 1000. So in this testbed the number of nodes contained in the network will be increased by

50 nodes starting with 50 nodes and up to 1000. The idea is to obtain a graph that shows how the network's performance is affected by the increase in the number of participants. It is also relevant to know if the network as it was designed, has the power and the ability to handle such number of participants as defined in the specifications, without a significant drop in its performance.

4.5 Acknowledgment

The simulations that has been run so far has only looked at the packets received in the base station, but not from a point of view of the sending node. In some situations the data sent over the wireless channel is critical enough to require a confirmation to the sender, when the data has arrived in good conditions. On the other hand, if the sender does not receive this confirmation or acknowledgment within a certain period of time, it will trigger a retransmission of the packet. The use of such a acknowledgment mechanism can assure delivery, but at the same time can provoke more traffic in the wireless channel and consequently even more collisions. Another important variable in this analysis is the not-delivery rate that the system tolerates. With hard constraints about the delivery imposed, a acknowledgment mechanism is mandatory, but in other cases the system can afford to miss some of the packets without collapsing. So in this testbed, transmissions with and without acknowledgment mechanism will be tested in order to evaluate the effects that such technique produces in the performance of the network.

On one hand, if a transmission without acknowledgment mechanism is proved to be enough, the system will automatically improve its lifetime, since the sending radio has no longer the need to wait for an acknowledgment packet and can switch to sleep mode right after the message was sent.

On the other hand, if acknowledgment packets are required, the parameters regarding such mechanism should be defined. The maximum number of retries a sensor node makes before it triggers a failure should be derived from the test results. The waiting time for an acknowledgment to come should also be derived from these results.

This testbed has been carried out for a network constituted for 1000 nodes evenly distributed in a rectangle and a base station placed in the middle. The number of nodes used represent the maximum number of participants supported by the system and it is based on the results of the testbed 4.4.

4.6 Data Rate

The transmission data rate has been obtained at the very beginning by cross-referencing the specification obtained, and the datasheet from a radio thought to be a match for this application. Since this moment the data rate used in all the

testbeds was set to 40 kbps. In this simulation the transmission data rate will be used as the testbed parameter in order to analyze the influences the data rate can have in other aspects of the system. During the simulation the parameter `**nic.mac.bitrate` will be changed from 5 to 40 kbps by steps of 5 kbps. It is expected that as we decrease the data rate, collisions between different packets become more feasible.

*NOTE: Even though `**nic.mac.bitrate`, the transmission bit rate, was modified during the simulation, `*.node[*].nic.phy.sensibility`, the sensibility to the radio, has been maintained to its value of -90 dB. This is not what actually happens in practice, because the sensibility of the radio will probably increase when the data rate decreases. By keeping the same sensibility value the results of the simulation will have a slightly better safe-margin, achieving at the same time a less complex simulation.*

4.7 Data Traffic

In this testbed the traffic in the network will be increased in order to stress the system and evaluate the limits in which the system is still operational. The event's frequency used in each node until now was, as described in 3.2.4 defined by a uniform distribution, with values between 0 and 30 minutes. In this simulation the upper variable will be gradually decreased from 30 to 10 minutes. A significant increase in the collisions is expected because the average number of transmissions per unit of time will be increasing.

The relevant parameters for this testbed are described below

- `*.numHost = 301` the number of sensor nodes in this simulation is 300 (+ 1 base station).
- `**appl.trafficParam = 5..30` by step 5 min the parameter adopts 6 different values from 5 to 30 minutes.
- `**appl.trafficType = uniform` this parameter is not modified during the simulation, but it is still relevant. Its value determines which type of distribution the traffic will have. The parameter can adopt the following three values: `periodic`, `uniform` and `exponer`.

Chapter 5

Results

In this chapter the results issued from the different simulations will be presented. In the next chapter, a discussion of these will be carried out.

Brief explanation about the results provided by the Physical Layer:

The packets arriving to the Physical Layer will be divided into six groups. These groups will represent to which degree the packet has successfully been interpreted by the receiver node.

The first categorization divides the received packets into those **WithInterference** and those **Withoutinterference**. In this case interference means all types of unwanted receptions that occurred while the message in question was being handled. A packet will be marked as **Partial** if for some reason the packet reception is not totally completed. These will be marked with **WithInterference** or **WithoutInterference** as well. Finally, a packet can also receive a **Dropped** mark, specifying that the message has been completely received, but errors in the content has corrupted the data and therefore the message is discarded.

5.1 Signal attenuation

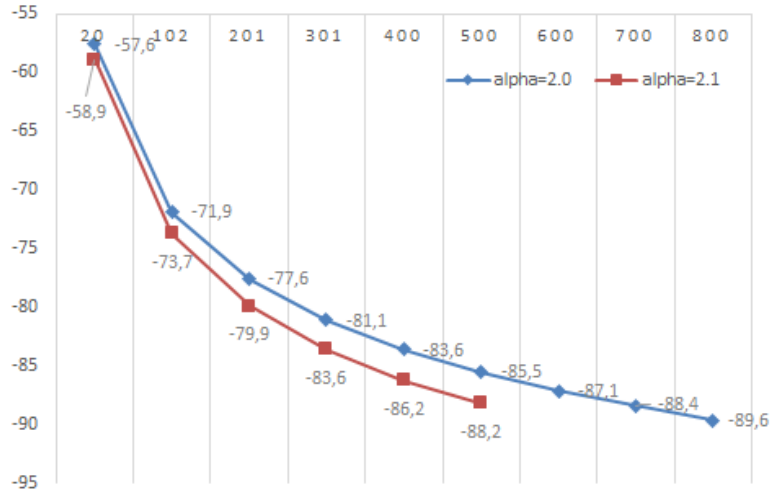

Figure 5.1: Lineal Attenuation

In figure 5.1 it is possible to see a direct relationship between the increasing distance from a transmitting node and the base station, and its attenuation. Since a radio sensibility of -90 dB has been specified, the maximum possible distance will be 800 and 500 meters for a system with a path loss coefficient α equal to 2.0 and 2.1 respectively. The results depicted in the figures 5.1 and 5.2 were derived from the equation 4.1.

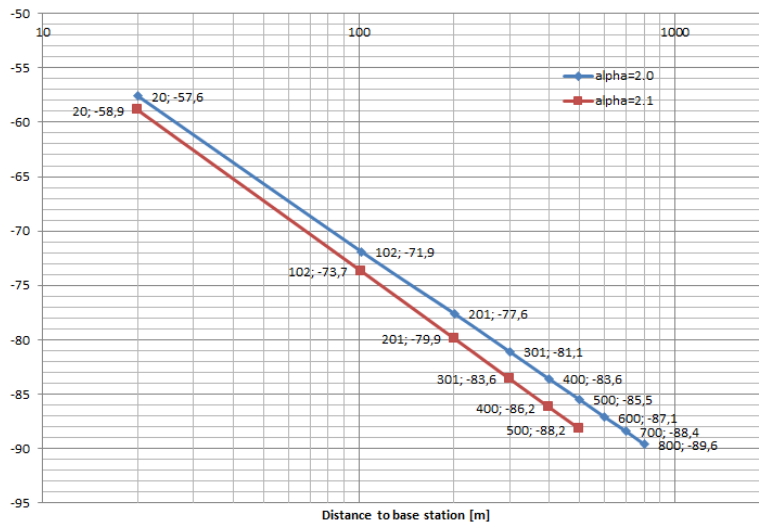

Figure 5.2: Logarithmic Attenuation

The figure 5.2 puts into evidence the logarithmic nature that the attenuation

function has over the distance.

5.2 Near-Far testbed

The results issued from the testbed 4.3 are presented in this section. From these results, it is desirable to get a picture about how fair the reception at the base station will be, in the case that all the sensor nodes transmit with the same power (no TxPower-Control implementation).

The first parameter analyzed is the Rx/Tx Ratio, depicted in the figure 5.3. Just as in the previous occasions Rx/Tx Ratio is defined by the formula 5.1 in section 5.3.

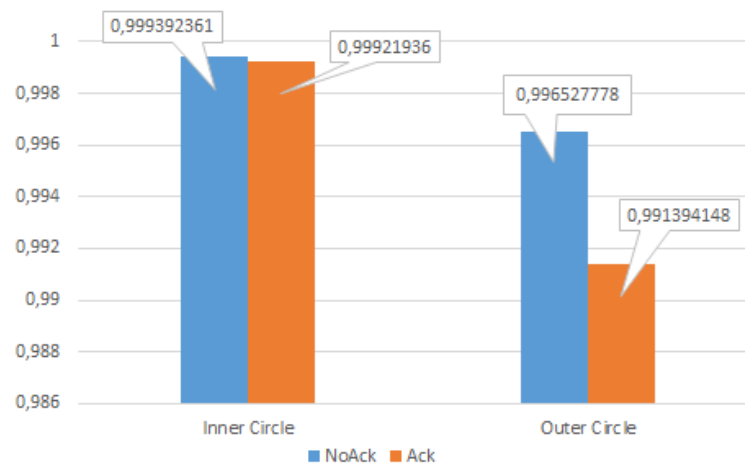

Figure 5.3: RxTx Ratio

In this case, the results presented in the figure 5.3 has been split in two groups; one including the nodes in the inner-circle, and one with the outer-circle nodes. This was made in order to be able to analyze them separately and see if one of these perform significantly better than the other. The equation 5.1 has been used to calculate the values.

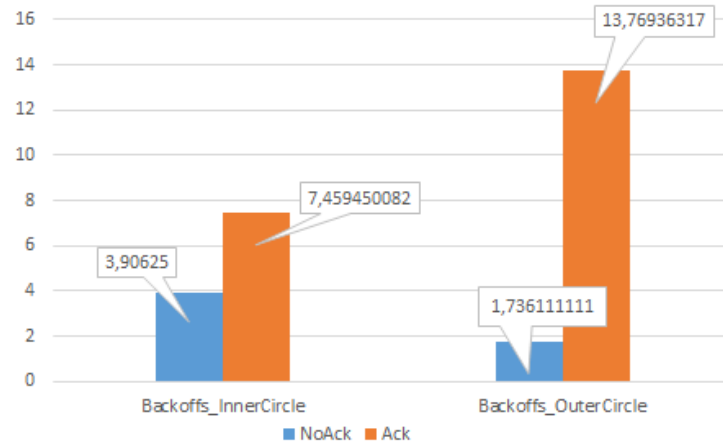

Figure 5.4: Backoffs

The same group division has been made in the figure 5.4. In this case the number of backoff per thousand packets sent is shown. The number of backoffs was calculated using the equation from 5.4 and the data issued from the simulation.

5.3 Maximum number of participants

The results shown in the following figures were derived from the data issued during the simulation. Some of them affect only to the base station, others to the sensor nodes and some to both. In each case the graph shows values for 20 different numbers of nodes conforming the network. These values go from 50 to 1000.

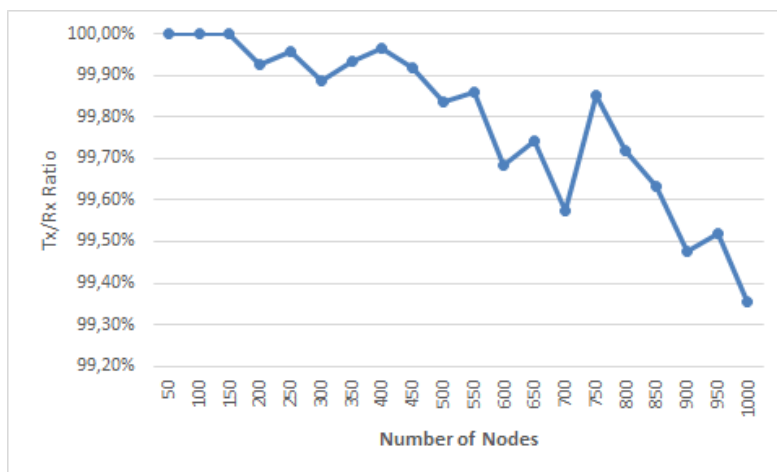

Figure 5.5: Rx/Tx Ratio [%]

A relationship between the number of packets sent from the sensor nodes to the base station is depicted in the figure 5.5. The results are expressed in percentage,

where a 100% means that the totality of the transmitted packets has been received by the base station. The function in 5.1 explains how the values in the graph were obtained.

$$f(x) = \frac{\text{QfreeNet.node}[0].\text{nic.mac.nbRxFrames}}{\text{QfreeNet.node}[*].\text{nic.mac.nbTxFrames}} \quad (5.1)$$

The same situation can be appreciated in the figure 5.6, with the difference that in this case, the number of missed packets are represented. The values have been normalized by the number of transmitted packets in order to obtain values that can be compared even though the number of nodes are not equal. The results were also multiplied by thousand in order to obtain values that can be more easily interpreted.

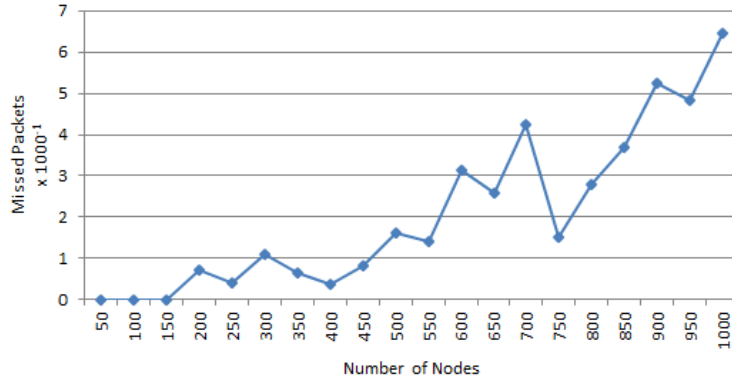

Figure 5.6: Missed Packets (normalized)

In the figure 5.6, the values of the y-axis should be interpreted as the number of missed packets per thousand sent packets. The expression that corresponds with the graph is presented below

$$f(x) = \frac{\text{node}[*].\text{nic.mac.nbTxFrames} - \text{node}[0].\text{nic.mac.nbRxFrames}}{\text{QfreeNet.node}[*].\text{nic.mac.nbTxFrames}} 1000 \quad (5.2)$$

The next graph shown in the figure 5.7 presents the number of acknowledgments that has been missed during the communication. It is important to remark that a missed acknowledgment does not mean that the packet was not delivered. One explanation can be that the packet did not arrive, but the reason can also be that the acknowledgment sent from the base station did not arrive to the sensor node. In both situations, if the maximal number of retries has not been exceeded, a new transmission is triggered and this can be enough to not miss the packet.

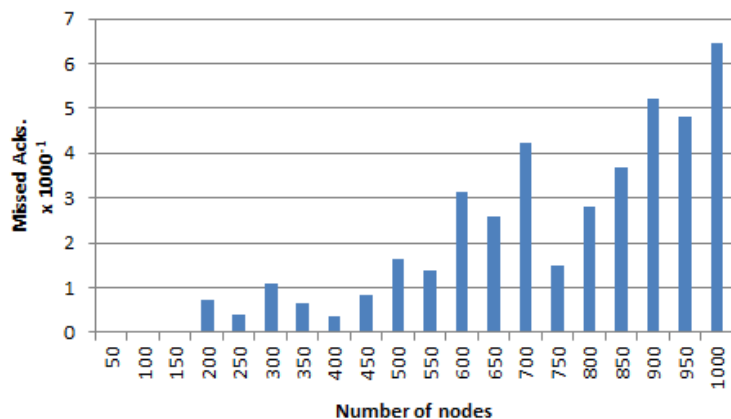

Figure 5.7: Missed Acknowledgments (normalized)

The values in the figure 5.7 were calculated by the following formula in 5.3 and represents the number of missed acknowledgments per thousand packets transmitted.

$$f(x) = \frac{\text{node}[*].\text{nic}.\text{mac}.\text{nbMissedAcks}}{\text{QfreeNet}.\text{node}[*].\text{nic}.\text{mac}.\text{nbTxFrames}} 1000 \quad (5.3)$$

Another parameter that has been analyzed from the data issued in the simulations is the number of backoffs the sensor node had to make before it was able to send. A Carrier Sense Multiple Access (CSMA) was used in these simulations as the Medium Access Control (MAC). This mechanism proposed that every communication starts with a backoff. So in order to represent just those that have been provoked as a consequence of the availability of the wireless channel, the first 48 backoffs have not been taken into consideration. 48 is the number of transmissions each sensor is configured to carry out. The figure 5.8 shows the number of backoffs per thousand packet transmissions. The expression used in this case obeys to the following formula

$$f(x) = \frac{\text{node}[*].\text{nic}.\text{mac}.\text{nbBackoffs} - (48 \times \text{nodes})}{\text{QfreeNet}.\text{node}[*].\text{nic}.\text{mac}.\text{nbTxFrames}} 1000 \quad (5.4)$$

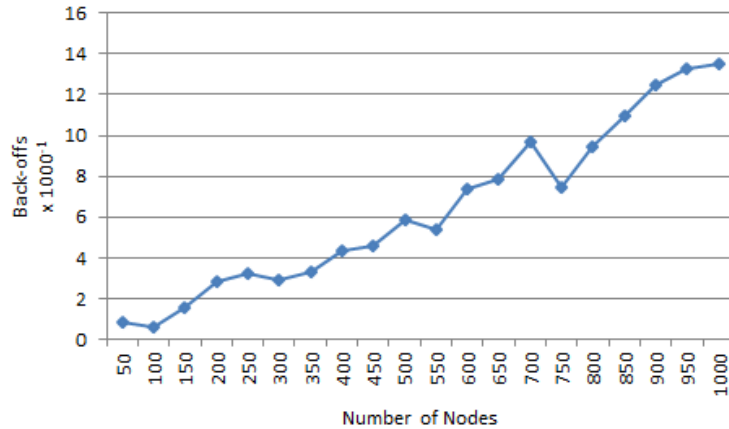

Figure 5.8: Backoffs

Along with the analysis of the number of backoffs, four graphs showing the latencies suffered by the base station are depicted in the figure 5.9. These graphs correspond to four different scenarios in the simulation; the graphs 5.9(a), 5.9(b), 5.9(c) and 5.9(d) show the situation when the network has 100, 300, 600 and 1000 nodes respectively. The data has been extracted from a vector generated during the simulation. In order to maintain the clearness of the data that will be presented, not all the scenarios of this simulation are plotted.

To conclude with this section, the figure 5.10 shows the number of frames that has been dropped per thousand packets sent. The definition of a **Dropped Frame** has been explained at the beginning of this chapter.

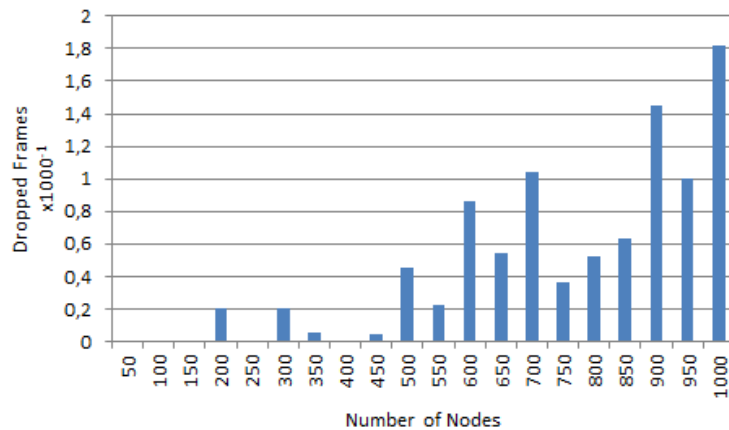

Figure 5.10: Dropped Frames

The equation 5.5 describes the figure 5.10.

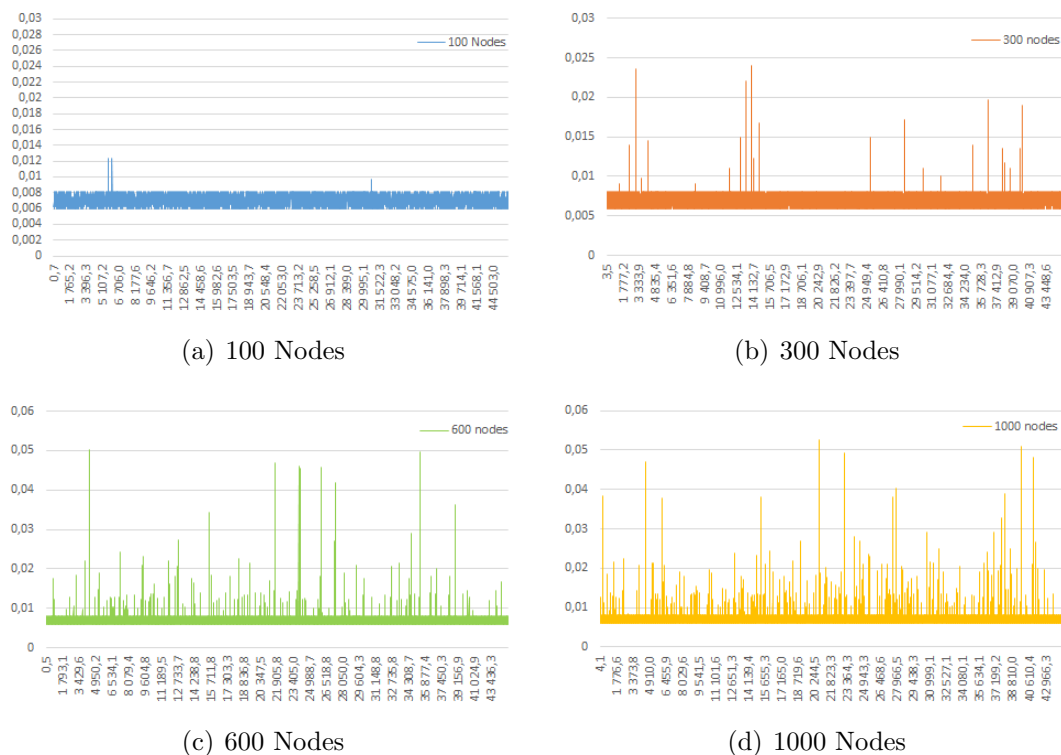

Figure 5.9: Latency time intervals

$$f(x) = \frac{\text{node}[0].\text{nic}.\text{phy}.\text{nbFramesWithInterferenceDropped}}{\text{QfreeNet}.\text{node}[*].\text{nic}.\text{mac}.\text{nbTxFrames}} 1000 \quad (5.5)$$

5.4 Acknowledgment mechanism

With the results of this simulation, an analysis of the system's behavior will be carried out. The analysis will try to figure out if there is a tendency within the result, depending on the presence or absence of the acknowledgment mechanism used in the MAC. Some of the parameters plotted in the section 5.3 will be analyzed again in this section. This time taking into consideration only the scenario where 1000 nodes are present. In fact the results from the system with acknowledgment mechanism has been reused from the previous section.

The Rx/Tx ratio depicted in the figure 5.11(a) shows how the system performs, based on the formula 5.1 from the section 5.3. In the figure 5.11(b) the number of missed packets per thousand packets sent is represented for both scenarios, with and without acknowledgments. The values presented obeys the formula 5.2. The

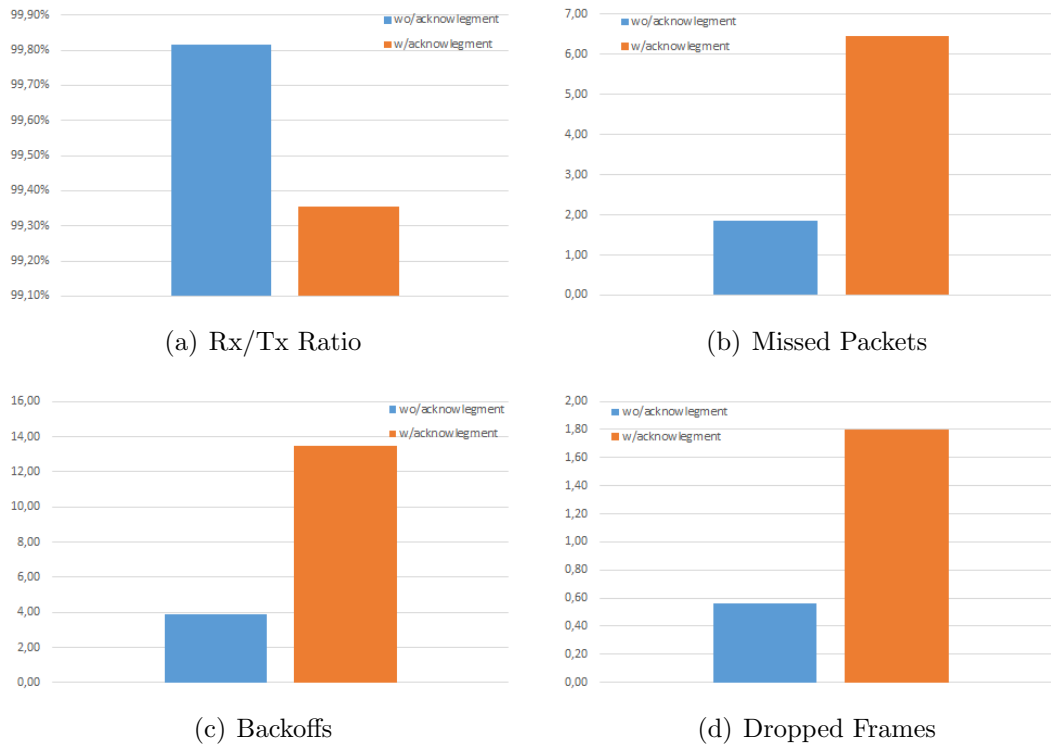

Figure 5.11: Different parameters from a system with (*orange color*) and without (*blue color*) the use of an acknowledgment mechanism

number of backoff are also expressed in the same way they have been expressed in the section 5.3; namely the number of extra backoffs per thousand packets sent. In the figure 5.11(d) it is possible to observe the number of frames that have been dropped per thousand packets sent. The formula 5.5 shows how these values have been calculated.

Concluding this section, two figures showing the latency time intervals for each scenario is presented bellow. The figure 5.12(a) represents the situation when the system does not use an acknowledgment mechanism.

In the figure 5.12(b) the latencies plotted corresponds with a system using acknowledgment mechanism.

5.5 Data Rate

The results presented in this section will enable the possibility to find an optimal communication data rate. Since the data rate has not been a constraint in the specifications detailed in section 1.2.1, the only concern are the consequences that a data rate decrease can have in the total performance of the system.

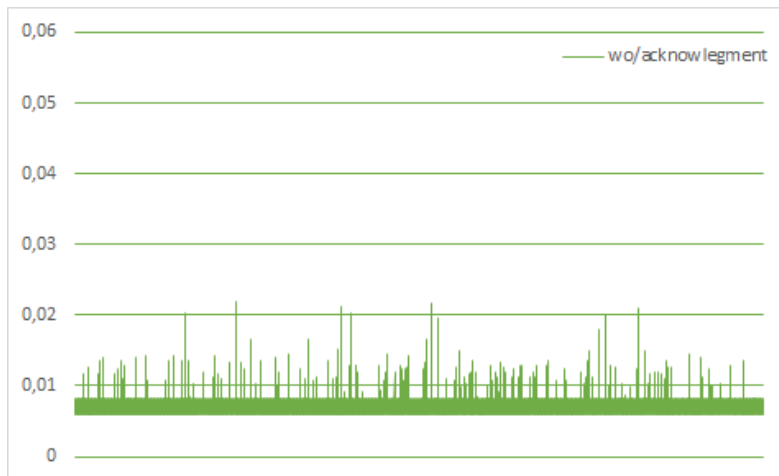

(a) 1000 Nodes without acknowledgment

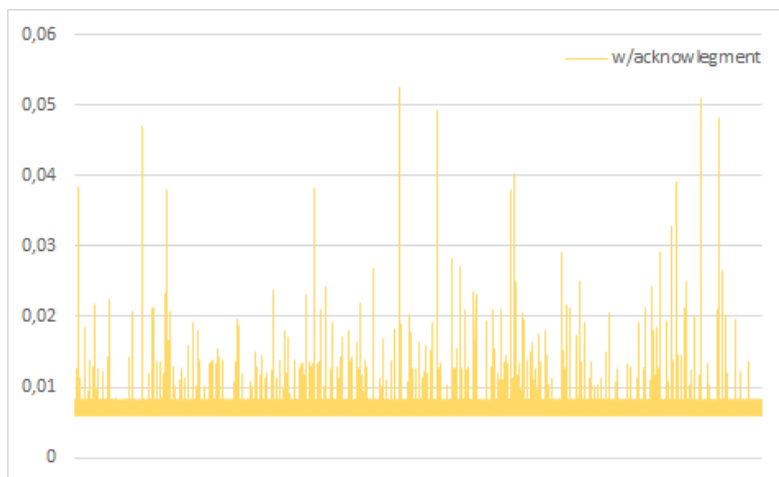

(b) 1000 Nodes with acknowledgment

Figure 5.12: Latency time intervals

The results start showing the Rx/Tx Ratio. As in the other previous sections this ratio is calculated by means of the equation 5.1. The values corresponding to the different scenarios can be appreciated in the figure 5.13.

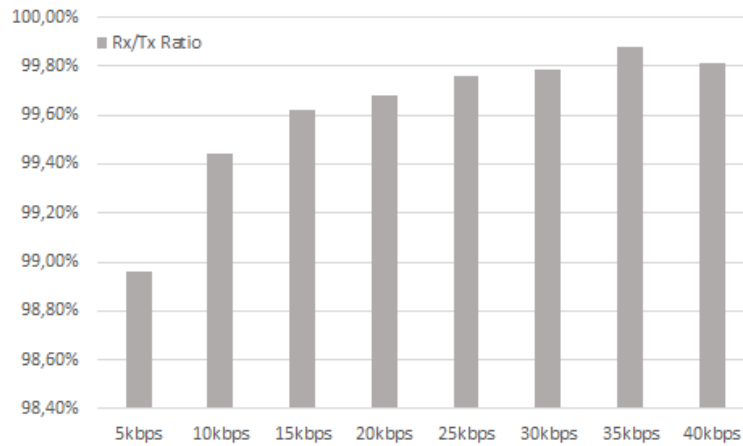

Figure 5.13: RxTx Ratio

The next results present the number of interfered packets per thousand packets sent. These interfered packets can at the same time be divided into three groups; namely `WithInterference`, `WithInterferencePartial` and `WithInterferenceDropped`. A description about these terms can be found at the beginning of the chapter 5. The values expressed in this graph correspond only to the interference observed in the base station. The interference in the sensor nodes is not considered here. The following formula has been used to generate the results

$$f(x) = \frac{\text{WithInterf} + \text{WithInterfPartial} + \text{WithInterfDropped}}{\text{nbTxFrames}} 1000 \quad (5.6)$$

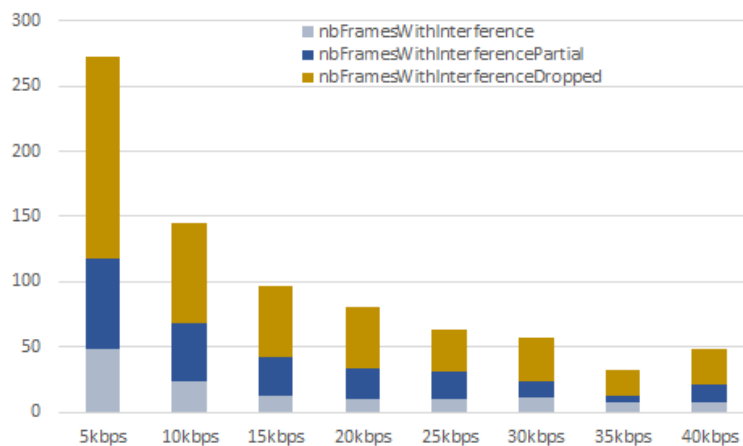

Figure 5.14: Interference

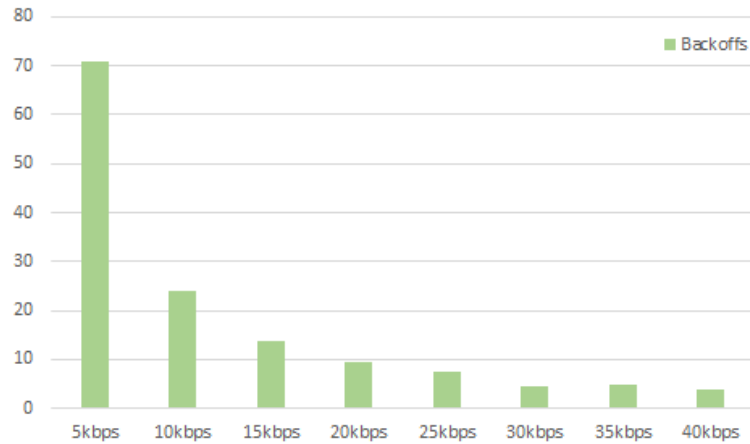

Figure 5.15: Backoffs

The last graph showing the number of backoff per thousand packets sent is depicted in the figure 5.15. As previously explained in other sections, the number of backoffs is defined by the formula 5.4 from section 5.3.

5.6 Data Traffic

The data issued from the Data Traffic testbed are the last results made in this investigation. The values obtained will try to increase the available information about how the system responds to increases in the network data traffic.

Continuing with the same structure as in the previous sections, the Rx/Tx Ratio is first depicted in the figure 5.16 and its values have been issued using the equation 5.1.

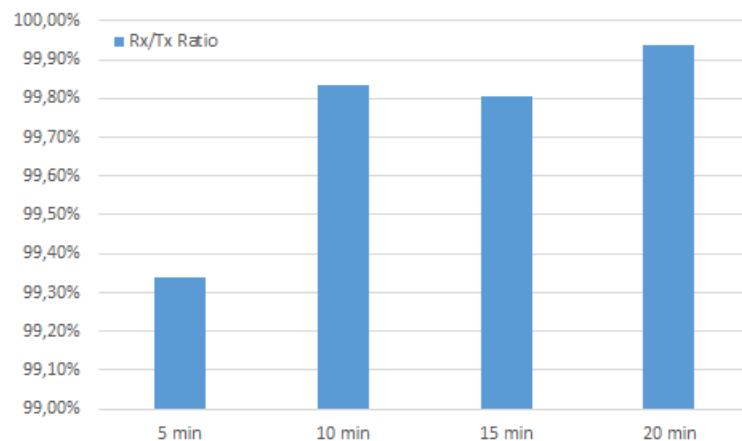

Figure 5.16: RxTx Ratio

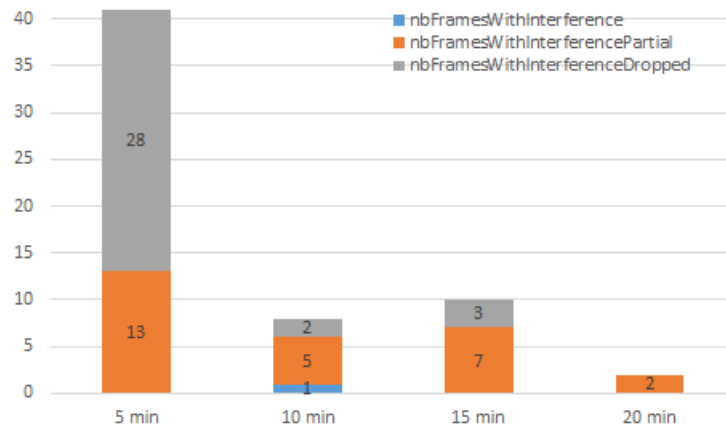

Figure 5.17: Interference

Above, a compilation of all the frames that have suffered some kind of interference in the base station are presented in Figure 5.17. The data depicted express the number of interferences per packet transmitted. Next, the resulting backoffs from the simulations are presented in Figure 5.18 and obey the already defined equation 5.4.

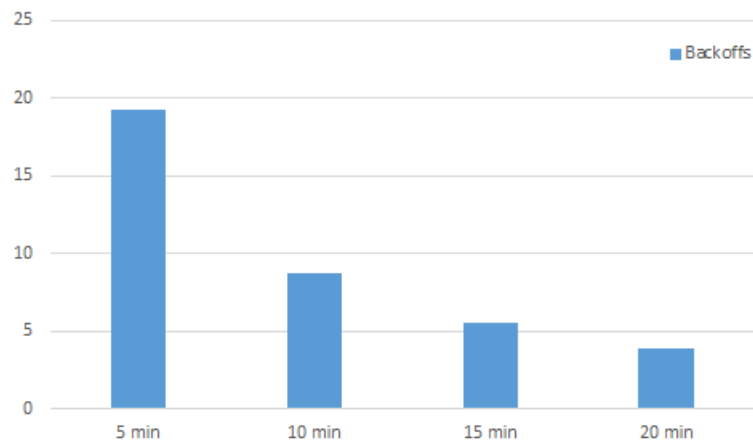

Figure 5.18: Backoffs

Finally, Figure 5.19 displays the number of acknowledgments that have been missed per thousand packets sent. The formula 5.3 was used in this graph in order to obtain the results shown.

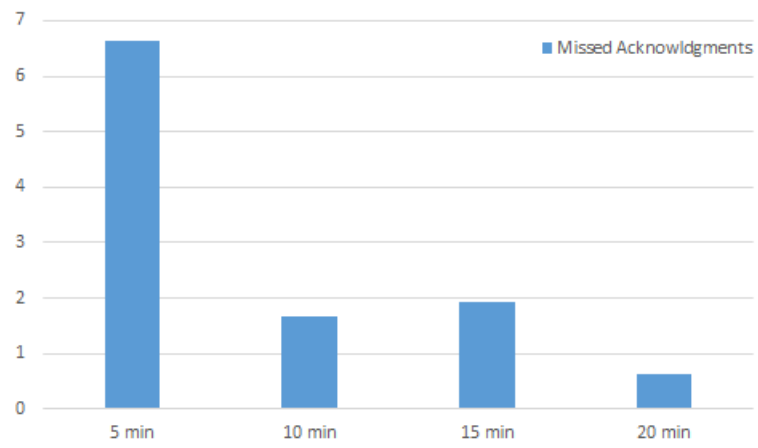

Figure 5.19: Missed Acknowledgments

Part IV
Conclusions

Chapter 6

Discussion of the results

This chapter aims to discuss the results presented in chapter 5. In order to achieve this, all the testbeds and its results will be reviewed.

Taking into consideration the testbed concerning the signal attenuations, and assuming that the system will operate in free-air, the range obtained in the simulation is acceptable. It is important to remember that the range value in the specification was between 500 and 1000 meters. If the system has to operate in more complex environments where there are sufficient obstacles and reflexions, a decrease in the communication range should be expected.

Analyzing now the results from the Near-Far testbed, it can be appreciated that on the one hand a slightly better throughput performance is observed in the nodes that constitute the inner-circle; namely those placed nearest the base station. But the difference is so small, less than 1%, making it difficult to conclude. A similar situation is presented when the number of backoffs is observed. On the other hand the consequences of using an acknowledgment mechanism seems to affect the total performance of the system more drastically. In this case both backoffs and Rx/Tx Ratio are improved or at least maintains its value (plus/minus an error consideration). These improvements affect the nodes in both the inner- and the outer-circle. The results are consistent with the fact that an acknowledgment mechanism will assure that no packet gets lost without notice, but incurring a cost to the network, namely the extra traffic that at the same time can provoke more interference, also called collisions.

The results from the simulations concerning the maximum number of participants, propose that the system has not reached an absolute maximum where the network collapsed, but rather that its performance has been weakened gradually. It seems possible to expect, according to the results obtained, that the network would be able to handle even more participants in the network. The factor that will limit this number seems to be primarily the constraints imposed to `MissedPackets`. Then the latency time interval can also be mentioned, but the specifications described in 1.2.1 do not put so much attention on the delays, at least not at this

level. An issue with the latencies is maybe not the delay itself, but the fact that the values becomes more variable and less predictable, as can be seen in the figure 5.9.

Maybe one of the most important questions that have arisen during these simulations is the interrogation about the use of an acknowledgment mechanism and what could eventually be its advantages or disadvantages. The results from the simulations carried out will help answer some of this interrogatives. In the figure 5.11 four different aspects that define the system's characteristics has been presented. At first impression, the performance of the system in general seems to be better. All four parameters deliver better results when the acknowledgment mechanism is not considered. Although the differences are modest, the avoidance of acknowledgments is consequently advantageous. The figures 5.11(b), 5.11(c) and 5.11(d) shows an improvement of three time for each parameter. And the figure 5.11(a) show an increase of almost 0,05% in the throughput.

The latency results for this section will be analyzed next. Using these results, previously presented in the figure 5.12, section 5.4 it is possible to find out which are the effects that the acknowledgments produce in the network. The more feasible explanation would be that when acknowledgments are required, the traffic will in practice be duplicated. So, in this case, where the packets transmitted are relatively small, the overhead imposed by the acknowledgment mechanism becomes impractical.

The next discussion has the variations of the transmission data rate used as its concern. As well as the changes that this will provoke to the system. The results delivered during the simulation are not surprising and indicate a decrease in the system's performance in general as the data rate becomes lower. An interesting point in the figure 5.15 and figure 5.14 is that it seems to be possible to decrease the data rate without the need of resigning to much performance. This could be relevant if extra communication range is necessary and extra sensibility can be achieved from the radio in exchange with a lower transmission data rate.

Finally, the results about the data traffic variations are again of no surprise, but they are important in order to be able to place the system being tested in a context. In this way it will be easier to know how much margin the system has. For example, based on the specifications imposed in 1.2.1 and the fact that it is possible, without much problem, to predict the amount of traffic the system will have, an analysis in data traffic seems unnecessary. But with this simulation it is desirable to map out all the possible situations where the system operates without major problems.

Chapter 7

Conclusion

The main goal of this thesis has been to find tools capable of carry out simulations in Wireless Sensor Networks (WSN), and from there carry out simulations that would enable the possibility of a much more powerful analysis. The purpose of the analysis was to characterize a wireless sensor network working under defined specifications and determine its viability.

The task concerning the search for the right simulation tools finished with the selection of an discrete event simulator called OmNET++ and a library specially designed to work with wireless sensor networks called Mixim. Both proved to have many strengths, like their versatility, flexibility and power, being able to simulate hundreds and even thousands of nodes and issuing millions of single events per simulation. One downside would be the lack of documentation, that slowed down the research process in the very beginning.

During the characterization of the wireless sensor network, several aspects have been discussed. In this case, the simulation tool aimed to issue the data necessary to approach the different interrogations in a systematic way, giving the opportunity to perform the tests and prove theories or assumptions without the necessity of real hardware. The results obtained from this investigation has been satisfactory, from the point of view that a model has been defined and it is ready for further development.

7.1 Future Work

This investigation finishes with a working model of a wireless sensor network capable of issue results, but that at the same time could be enriched in order to increase the fidelity of the already implemented functions or simply model new functionalities.

One possible area of interest is the modeling of a multidimensional signal that is capable of being evaluated according not only to its position in time, but also

to its frequency. And consequently achieving a model capable of evaluating the influence that other equipments in the area could have over the system, even if these transmit in another carrier frequency.

References

- [1] Abed, A. (2012). Mac layer overview for wireless sensor networks. Cited on page 20.
- [2] Ahmed, H. and M. Khurram (2014). Performance analysis of mac layer protocols in wireless sensor network. *International Journal of Information Engineering and Electronic Business (IJIEEB)* 6(5), 44. Cited on page 3.
- [3] Boulis, A. *Castalia A simulator for Wireless Sensor Networks and Body Area Networks User Manual*. Cited on page 17.
- [4] Chen, F. and F. Dressler (2007). A simulation model of ieee 802.15. 4 in omnet+. *6. Fachgespräch Sensornetzwerke*, 35. Cited on page 4.
- [5] Koepke, A., M. Swigulski, K. Wessel, D. Willkomm, P. T. K. Haneveld, T. E. V. Parker, O. W. Visser, H. S. Lichte, and S. Valentin (2008). Simulating wireless and mobile networks in omnet++ the mixim vision. In S. Molnr, J. R. Heath, O. Dalle, and G. A. Wainer (Eds.), *SimuTools*, pp. 71. ICST. Cited on page 18.
- [6] Kredo, K. and P. Mohapatra (2007). Medium access control in wireless sensor networks. *Computer networks* 51(4), 961–994. Cited on page 12.
- [7] Nguyen, V., M. Gautier, and O. Berder (2014). Implementation of an adaptive energy-efficient MAC protocol in omnet++/mixim. *CoRR abs/1409.0991*. Cited on page 20.
- [8] Stehlik, M. (2011). Comparison of simulators for wireless sensor networks. Master’s thesis, MASARYK UNIVERSITY. Cited on pages xi, 16, 17.
- [9] Swigulski, K. W. M. (2007). Mixim - physical layer. Cited on page 22.
- [10] Varga, A. (2014). *OMNeT++ User Manual*. Cited on page 17.
- [11] Wessel, K., M. Swigulski, A. Köpke, and D. Willkomm (2009). Mixim: the physical layer an architecture overview. In *Proceedings of the 2nd International Conference on Simulation Tools and Techniques*, pp. 78. ICST (Institute for Computer Sciences, Social-Informatics and Telecommunications Engineering). Cited on pages 21, 22, 23.

Appendix

Omnetpp.ini

This appendix comprises the omnetpp.ini file used for this investigation.

```
\texttt{[General]
cmdenv-config-name =
cmdenv-event-banners = true
cmdenv-module-messages = true
cmdenv-runs-to-execute =
network = QfreeNet
record-eventlog = false
tkenv-image-path = ../../images;
sim-time-limit = 28h
#cpu-time-limit =
#####
# Simulation parameters                                     #
#####
tkenv-default-config =
**.coreDebug = true
**.debug = true
*.playgroundSizeX = 2000m
*.playgroundSizeY = 2000m
*.playgroundSizeZ = 40m
*.numHosts = 2
#####
# WorldUtility parameters                                   #
#####
*.world.bitrate = 40000
#####
#           channel parameters                             #
#####
*.connectionManager.sendDirect = false
*.connectionManager.pMax = 1.0 mW
*.connectionManager.sat = -90 dBm
*.connectionManager.alpha = 2.0 #free space
*.connectionManager.carrierFrequency = 900E+6 Hz #900Mhz
```

```

#####
#           PhyLayer parameters           #
#####
*.node[*].nic.phy.usePropagationDelay = true
*.node[*].nic.phy.analogueModels = xmldoc("config.xml")
*.node[*].nic.phy.sensitivity = -90 dBm
*.node[*].nic.phy.maxTXPower = 1.0 mW
*.node[*].nic.phy.initialRadioState = 0 #0=RX, 1=TX, 2=Sleep
*.node[*].nic.phy.radioMinAtt = 1.0
*.node[*].nic.phy.radioMaxAtt = 0.0
*.node[*].nic.phy.thermalNoise = -110 dBm
*.node[*].nic.phy.useThermalNoise = true
##### MAC layer parameters #####
**.nic.mac.notAffectedByHostState = true
**.nic.mac.txPower = 1.0mW
**.nic.mac.rxSetupTime = 0.0018s
**.nic.mac.macMinBE = 3
**.nic.mac.macMaxBE = 8
**.nic.mac.bitrate = 40000 bps #default 250kbps
**.nic.mac.macMaxCSMABackoffs = 5
**.nic.mac.macMaxFrameRetries = 3
**.nic.mac.macAckWaitDuration = 0.0035 s
**.nic.mac.useMACAcks = true
**.nic.mac.trace = true
##### NETW layer parameters #####
**.netw1.headerLength = 16bit
##### Appl layer parameters #####
**.node[0].appl.nbPackets = 0
**.node[0].appl.broadcastPackets = true
**.appl.trafficType = "uniform"
**.appl.trafficParam = 30min #${traffic = 1..19 step 2}s
**.appl.nbPackets = 48
**.appl.initializationTime = 0.5s
**.appl.destAddr = 0
**.appl.broadcastPackets = false
**.appl.stats = true
**.appl.trace = true
##### Mobility parameters #####
**.mobility.initFromDisplayString = false
*.node[0].mobility.initialX = 1000m
*.node[0].mobility.initialY = 1000m
*.node[0].mobility.initialZ = 20m
#####

```

```

#           Configurations           #
#####
[Config Traffic]
description = "Increment traffic to find collapse point"

*.numHosts = 301 #max
**.appl.trafficParam = ${traffic = 5..30 step 5}min
*.node[*].mobility.initialZ = 0m

[Config Max_Distance]
description = "Calculate the maximum distance
between a sensor and the base station"

*.numHosts = 2
*.node[0].mobility.initialX = 1000m
*.node[0].mobility.initialY = 1000m
*.node[0].mobility.initialZ = 20m
*.node[1].mobility.initialX = 1000m - ${dist = 0..800 step 100}m
*.node[1].mobility.initialY = 1000m
*.node[1].mobility.initialZ = 0m

[Config Det_position]
*.numHosts = ${nodes=51..1001 step 50}

*.node[0].mobility.initialX = 1000m
*.node[0].mobility.initialY = 1000m
*.node[0].mobility.initialZ = 20m
*.node[*].mobility.initialZ = 0m

[Config DataRate]
extends = Det_position

*.node[*].nic.mac.useMACAcks = false
**.nic.mac.bitrate = ${rate = 5000..40000 step 5000}bps
*.node[*].mobility.initialX = fmod((parentIndex()-1),10)*100m + 200m
*.node[*].mobility.initialY = ceil(parentIndex()/10)*200m + 200m
*.node[*].mobility.initialZ = 0m

[Config Far_Near_ack]
sim-time-limit = 9h

*.numHosts = ${nodes=17}
*.node[0].mobility.initialX = 1000m

```

```

*.node[0].mobility.initialY = 1000m
*.node[0].mobility.initialZ = 30m

*.node[*].mobility.initialX = parentIndex() < ({nodes}/4)? 1000m
+ 100m * cos(parentIndex()*(6.283185/({nodes}-1)*4)) : 1000m
+ 800m * cos(parentIndex()*(6.283185/({nodes}-1)*4/3))
*.node[*].mobility.initialY = parentIndex() < ({nodes}/4)? 1000m
+ 100m * sin(parentIndex()*(6.283185/({nodes}-1)*4)) : 1000m
+ 800m * sin(parentIndex()*(6.283185/({nodes}-1)*4/3))
*.node[*].mobility.initialZ = 0m
**.nic.mac.useMACAcks = true
**.nic.mac.bitrate = 34000bps
**.nic.mac.macAckWaitDuration = 0.0056 s
**.netwl.headerLength = 0bit
**.netwl.stats = true
**.node[0].appl.nbPackets = 0
**.node[0].appl.broadcastPackets = true
**.appl.trafficType = "uniform"
**.node[5..16].appl.trafficParam = 1min
**.appl.trafficParam = 10s #${traffic = 1..19 step 2}s
**.node[5..16].appl.nbPackets = 48
**.appl.nbPackets = 2880
**.appl.initializationTime = 1s
**.appl.destAddr = 0
**.appl.broadcastPackets = false
**.appl.stats = true
**.appl.trace = true

[Config Far_Near_no_ack]
extends = Far_Near_ack

**.nic.mac.useMACAcks = false

}

```