



**NTNU – Trondheim**  
Norwegian University of  
Science and Technology

# Ground Fault in Shipboard DC Power System

**Torfinn Årdalsbakke**

Master of Science in Electric Power Engineering

Submission date: June 2015

Supervisor: Lars Einar Norum, ELKRAFT

Co-supervisor: Kenneth Tjong, Siemens

Norwegian University of Science and Technology  
Department of Electric Power Engineering



# Problem description:

Candidate: Torfinn Skaiå Årdalsbakke

Project name: Ground fault in shipboard DC power system

Task:

In a Shipboard DC power system, large parts of the system will be connected without galvanic separation. If a ground fault occur in the system, the system need to handle the fault without interfering with normal operations. Ground fault can occur in different places and with different consequences for the operational reliability of the system.

The task consists of the following:

- Simulate a model of a specified Shipboard DC power system in Matlab/Simulink. Among other, the model need to include generator, rectifier, DC-bus, cables, converters, battery and loads.
- Simulate ground faults in different parts of the system and analyze how the ground faults affect the system. A simulation with different fault path resistance should also be conducted.

The task should evaluate:

- What damage the different ground faults can cause the system?
- What solutions can be used in order to locate ground faults at different places in the system?
- How should the system handle a ground fault?
- What type of grounding system should be applied in this vessel?

The task is based on a Shipboard DC project that is under development at Siemens. The vessel supply a DC feed to an external bus connected to several minor inverters delivered by other companies.

Figure 1 show a single line presentation of the bus, which is to be modeled in Matlab/Simulink.

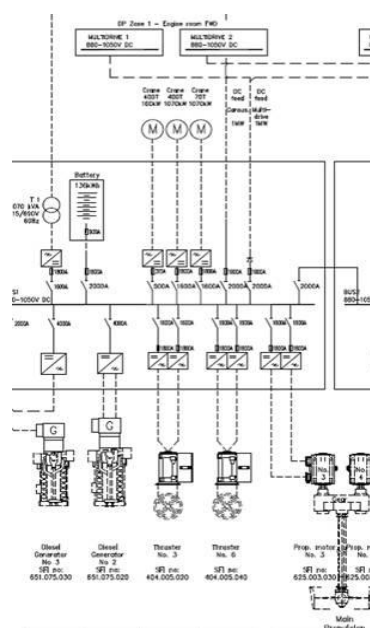

Figure 1 Single line sketch of the bus in question



# Preface

This thesis was written in the spring semester of 2015 and is the final work of the 2-year master program “electrical power engineering” at the Norwegian university of science and technology NTNU in Trondheim. The Thesis is written for the department of electric power engineering at the institute of information technology, mathematics and electronics IME.

Siemens Marine in Trondheim proposed the problem addressed in the project as a part of their design phase when designing a new offshore construction vessel with a shipboard DC power distribution called BlueDrive PlusC.

I would like to thank my supervisor professor Lars Norum at the department of electrical engineering and Amin Hajizadeh postdoc at the department of electrical engineering for taking the time to answer my questions and helping me with my simulations.

I would also thank my supervisors at Siemens Marine, Kenneth Presttun Tjong and Ida Larsen Loen for taking time to answer my questions and for helping me understand the system in question.

Torfinn Skaiå Årdalsbakke

Trondheim, juni 2015



# Abstract

The report first present the ship considered in the task. The theory part of the thesis gives a short introduction to dynamic positioning and the requirements the different DPS classes' puts on the ship. Then the principal buildup of different grounding configurations is explained. A short presentation of the difference between ground faults in AC and DC systems is given before different methods for detecting ground faults in the different systems are presented. The last chapter in the theory part address the protection systems ability to handle ground faults and short circuits.

When designing the simulation model some simplifications where made. The model is not a complete replica of the bus defined by Siemens. The model consists of enough components to create a representative model of the system. A larger model is unnecessary large and complex. In order to reduce complexity of the model, no dynamic components are used. When removing dynamic components, the system becomes very stable in normal operations even during short simulations.

The main concern for this thesis is how the first ground fault in different part of the system affect the normal operation of the system. Concerns related to how a ground fault on the AC side affect the DC bus and further the AC side of different inverters are put forth.

Simulations show that the first ground fault would not affect normal operation of the system. The only effect is that the voltage stress across the insulation increases. The report also show that a second ground fault anywhere else in the system would give a large fault current that affect normal operation of the system.

If a ground fault have occurred, detection that there actually is a fault somewhere in the system is easy. Locating and clearing or reducing the probability of a sub-sequent fault is much harder. Detection can be done by monitoring the voltage between the phases and ground on the DC bus. If one phase collapse to ground or the voltage ripple is from zero to phase-phase voltage, a fault is present in the system. In this case, it is important to localize and clear, or reduce the probability of a second ground fault from occurring in the same electric zone as soon as possible. This report present different technique for locating ground faults in the system. Presentation of how the system could locate ground faults to different degrees of precision is also suggested. Further, it is recommended that the system take action in order to reduce the chance of a second fault occurring in the same electrical zone as the first. This can be done by isolating the faulty bus from the rest of the system.

An analyze of what grounding system is more feasible in this type of vessel is presented. The analyze takes in mind the different strengths and weaknesses of the different grounding schemes and compare them to the most important operational requirements of the vessel. Since the most important feature is operational reliability, the IT system is considered the most suitable grounding system for this type of vessel.





# Sammendrag

Masteroppgaven gir en kort presentasjon av hvilken type skip som er betraktet som utgangspunkt for simuleringene. I teoridelen blir det gitt en kort introduksjon til hvordan dynamisk posisjonering fungerer og hvilke krav det stiller til skipet. Diverse jordingssystem blir presentert, og forskjellen på hvordan jordfeil påvirker AC nett og DC nett blir diskutert. Forskjellige jordfeil lokaliserings metoder blir presentert før jordfeil og kortslutnings beskyttelse blir utgreid.

Diverse forenklinger ble gjort når en av bussene i skipet skulle modelleres. Modellen er ikke en nøyaktig kopi av den oppgitte Siemens bussen. Modellen inneholder nok komponenter for å lage en representativ modell, men ikke så mange komponenter at modellen blir unødvendig kompleks. For å ytterligere redusere kompleksiteten i modellen ble det ikke benyttet dynamiske komponenter i modellen. Ved å benytte spenningskilder og faste laster i stedet for dynamiske komponenter blir systemet veldig stabilt selv ved korte simuleringer.

Hovedfokuset i denne oppgaven er å analysere hvordan første jordfeil påvirker forskjellige deler av systemet. Bekymringer for hvordan første jordfeil ville påvirke systemet, spesielt i kombinasjon mellom AC og DC er grunnlaget for at oppgaven er gitt.

Simuleringene viser at første jordfeil ikke har noen innvirkning på normal drift av systemet. Eneste forskjell er at spenningen over isolasjonen øker til nesten det dobbelte mellom fase og jord sammenlignet med normal drift. Simuleringene viser også at en eventuell andre jordfeil vil gi store feilstrømmer som vil påvirke normal drift av systemet.

Dersom det er oppstått en jordfeil i systemet er det relativt enkelt å detektere at feilen faktisk er tilstede i systemet. Dette kan gjøres ved å måle spenningen mellom fase og jord på DC bussen. Dersom det måles null volt potensiale mellom fase og jord eller spennings rippelen mellom fase og jord er den samme som fase-fase spenningen, er det oppstått en jordfeil. Når en jordfeil har oppstått er det viktig å lokalisere jordfeilen for så å fjerne eller begrense sannsynligheten for at en andre jordfeil vil gi en lukket krets mellom to faser. Rapporten presenterer forskjellige lokaliseringsteknikker og diskuterer hvor nøye systemet burde være i stand til å automatisk finne feilen. Det er også diskutert hvordan systemet burde håndtere feil når den er oppdaget for å redusere sannsynligheten for en ny feil. Systemet kan blant annet isolere bussen med feil fra de friske bussene.

Til slutt er en analyse av hvilken type jordingssystem som burde benyttes i denne typen skip presentert. Analysen ser på de forskjellige styrkene og svakhetene som de forskjellige jordingssystemene tilbyr og sammenligner dem med behovene for denne typen skip. Siden den viktigste design kriteriet er operasjonssikkerhet, er IT system valgt som det beste jordingssystemet for denne typen skip.



# Table of Contents

|       |  |    |
|-------|--|----|
| 1     | Introduction.....  | 1  |
| 1.1   | Background.....  | 2  |
| 2     | Theory.....  | 3  |
| 2.1   | Introduction:.....   | 3  |
| 2.2   | Dynamic positioning.....   | 3  |
| 2.2.1 | How it works.....  | 3  |
| 2.2.2 | Redundancy.....  | 4  |
| 2.2.3 | Classification and Requirements.....   | 4  |
| 2.3   | Grounding system.....  | 5  |
| 2.3.1 | TN System.....   | 5  |
| 2.3.2 | TT System.....   | 6  |
| 2.3.3 | IT System.....   | 7  |
| 2.4   | Ground fault in DC power systems compared to AC power systems.....                 | 8  |
| 2.5   | Different categories of ground faults.....   | 8  |
| 2.6   | Methodologies for locating ground faults.....                                      | 9  |
| 2.7   | System protection.....   | 10 |
| 2.7.1 | Protection of ground faults.....   | 10 |
| 2.7.2 | Requirements for short circuit system protection.....                              | 10 |
| 2.7.3 | Working principle and challenges with semiconductor based current interruption.... | 11 |
| 2.7.4 | Generator protection.....  | 11 |
| 2.7.5 | Protection of drives.....  | 12 |
| 2.7.6 | Bus-tie breaker.....   | 12 |
| 3     | Modeling the Shipboard DC power system.....  | 13 |
| 3.1   | Designing the model.....   | 13 |
| 3.1.1 | The principal buildup of the model.....  | 13 |
| 3.1.2 | Simplifications and assumptions.....   | 14 |
| 3.1.3 | Structural buildup of the MATLAB Simulink model.....                               | 15 |
| 3.1.4 | Sub systems.....   | 16 |
| 3.2   | Normal operation.....  | 17 |
| 3.2.1 | Generator.....   | 17 |
| 3.2.2 | Siemens bus.....   | 18 |
| 3.2.3 | External DC-bus.....   | 19 |
| 3.2.4 | Thrusters.....   | 20 |

|       |  |    |
|-------|--|----|
| 3.2.5 | Engine 6 .....   | 21 |
| 3.2.6 | Battery .....  | 22 |
| 4     | Fault simulations: .....   | 23 |
| 4.1   | One phase ground fault.....  | 23 |
| 4.1.1 | Ground fault in generator .....  | 23 |
| 4.1.2 | Ground fault in Thruster.....  | 28 |
| 4.1.3 | Ground fault in Engine 6.....  | 32 |
| 4.1.4 | Ground fault on the external DC bus.....   | 33 |
| 4.1.5 | Ground fault with high impedance .....   | 36 |
| 4.1.6 | Ground fault with reduced resistance path to N-point of generator.....               | 38 |
| 4.2   | Two phase ground fault.....  | 39 |
| 4.2.1 | Ground fault on phase “a” on the AC side of separate inverters.....                  | 39 |
| 4.2.2 | Ground fault in Thruster 1 and Generator .....                                       | 41 |
| 4.2.3 | Ground fault on DC bus in combination with ground fault in Thruster 1 or Engine 6 .. | 47 |
| 5     | Locating and handling ground faults in Shipboard DC power system.....                | 55 |
| 5.1   | Ground fault localization in IT grounding systems.....                               | 55 |
| 5.1.1 | Fast Fourier analysis .....  | 55 |
| 5.1.2 | Traveling wave analysis .....  | 55 |
| 5.1.3 | Localization by noise analysis from power electronic converters.....                 | 56 |
| 5.1.4 | Bender ground detection and location system .....                                    | 56 |
| 5.2   | Suggestions for placing of current transformers for location of faults.....          | 58 |
| 5.2.1 | Solution with good ability to automatic locate faults .....                          | 58 |
| 5.2.2 | Solution with limited ability of detecting fault location.....                       | 59 |
| 5.2.3 | Solution with medium localization capability .....                                   | 59 |
| 5.3   | Ground fault location in TT grounding system.....                                    | 60 |
| 5.4   | The external DC bus.....   | 61 |
| 6     | Analyze of grounding system for the ship.....  | 63 |
| 7     | Discussion .....   | 65 |
| 8     | Conclusion .....   | 67 |
| 9     | Bibliography.....  | 69 |
| 10    | Recommendation for further work .....  | 71 |
|       | Appendices .....   | 73 |

## Figures:

|   |    |
|---|----|
| Figure 1 Single line sketch of the bus in question .....  | i  |
| Figure 2 A ships freedoms of movements and forces .....   | 3  |
| Figure 3 TN-C-S grounding system .....  | 5  |
| Figure 4 TT-grounding system .....  | 6  |
| Figure 5 IT grounding system .....  | 7  |
| Figure 6 Single-line diagram overview of the studied shipboard dc hybrid power system .....       | 13 |
| Figure 7 MATLAB Simulink model .....  | 15 |
| Figure 8 Current, Voltage and Power results from Generator measure block in normal operation .... | 17 |
| Figure 9 DC current on the output of the rectifier in normal operation.....                       | 18 |
| Figure 10 Average DC current on the output of the rectifier in normal operation .....             | 18 |
| Figure 11 Voltage measurements on the Siemens DC bus in normal operation .....                    | 19 |
| Figure 12 Average and real DC current through the DC feed in normal operation .....               | 19 |
| Figure 13 Voltage measurements on the external DC bus in normal operation .....                   | 20 |
| Figure 14 Current, Voltage and power results from Thrusters in normal operation .....             | 20 |
| Figure 15 Average DC current through converter 1 in normal operation.....                         | 21 |
| Figure 16 Current, Voltage and power results from engine 6 in normal operation .....              | 21 |
| Figure 17 Average DC current through converter 6 in normal operation.....                         | 22 |
| Figure 18 charging current to battery in normal operation .....                                   | 22 |
| Figure 19 Placement of AC fault generator for generator fault simulation .....                    | 23 |
| Figure 20 Voltage readings for voltage between the phases, and phases and ground. ....            | 24 |
| Figure 21 Fault current through the fault generator .....   | 24 |
| Figure 22 Voltage between +/- and ground, and between + and – phase of the Siemens DC bus .....   | 25 |
| Figure 23 Zoomed version of Figure 22. Fault occurs at 0.2 sec. ....                              | 25 |
| Figure 24 charging current to battery average and real. Fault occur at 0.2 sec. ....              | 26 |
| Figure 25 RMS voltage, current and power measurements on Thruster. Fault occur at 0.2 sec.....    | 26 |
| Figure 26 Voltage between phase a, b and c and ground .....                                       | 27 |
| Figure 27 Illustration of placement of fault generator (red).....                                 | 28 |
| Figure 28 Voltage between phases and ground at thruster terminals with a fault at thruster 1..... | 28 |
| Figure 29 Fault current with a fault at thruster 1.....   | 29 |
| Figure 30 Voltage at the Siemens DC bus with a fault at thruster 1 .....                          | 29 |
| Figure 31 voltage measurements at generator terminals with a fault at thruster 1 .....            | 30 |
| Figure 32 Voltage measurements on terminals of engine 6 with a fault at thruster 1.....           | 31 |
| Figure 33 Voltage measurements on terminals of engine 6 with different controller algorithm ..... | 31 |
| Figure 34 Voltage at Siemens DC bus with a ground fault at Engine 6 .....                         | 32 |
| Figure 35 Voltage at external bus with a ground fault at Engine 6.....                            | 32 |
| Figure 36 Illustration of placement of DC fault generation block .....                            | 33 |
| Figure 37 fault current with a fault on the external DC bus.....                                  | 33 |
| Figure 38 Voltage on external DC bus with a fault on the external DC bus .....                    | 34 |
| Figure 39 Voltage at Siemens DC bus with a fault on the external DC bus.....                      | 34 |
| Figure 40 Voltage measurements at generator terminals with a fault on the external DC bus .....   | 35 |
| Figure 41 Voltage measurements at thruster terminals with a fault on the external DC bus .....    | 35 |
| Figure 42 fault current with 20kohm fault impedance .....   | 36 |
| Figure 43 Voltage measurements on the Siemens DC bus with 20kohm fault impedance .....            | 36 |
| Figure 44 Voltage measurements on generator terminals with 20kohm fault impedance .....           | 37 |
| Figure 45 fault current in real and RMS with 1Mohm resistance path to neutral point .....         | 38 |
| Figure 46 fault current in real and RMS with 0.5Mohm resistance path to neutral point .....       | 38 |

|  |    |
|--|----|
| Figure 47 Fault current through ground fault on thruster 1 .....   | 40 |
| Figure 48 Voltage on the external DC bus when faults occur in phase on different inverters .....         | 40 |
| Figure 49 Illustration of placement of fault generators .....  | 41 |
| Figure 50 Fault current in real current and RMS current with faults in generator and thruster 1 .....    | 42 |
| Figure 51 Voltage between phases and ground in the generator with faults in gen. and thruster 1...       | 42 |
| Figure 52 Current, Voltage and power on the Generator with faults in generator and thruster 1 .....      | 43 |
| Figure 53 Output current through the rectifier with faults in generator and thruster 1.....              | 43 |
| Figure 54 Voltage on Siemens DC bus with faults in generator and thruster 1 .....                        | 44 |
| Figure 55 Battery charging current with faults in generator and thruster 1.....                          | 44 |
| Figure 56 Current from neutral point of generator to ground with faults in generator and thruster 145    |    |
| Figure 57 Current in DC feed cable with faults in generator and thruster 1.....                          | 45 |
| Figure 58 Voltage between phases and ground on thruster 1 with faults in gen. and thruster 1.....        | 45 |
| Figure 59 Current, Voltage and Power on thruster 1 with faults in generator and thruster 1 .....         | 46 |
| Figure 60 Current, voltage and power of engine 6 with faults in generator and thruster 1.....            | 46 |
| Figure 61 Illustration of placement of DC fault generator, and the fault generator at Engine 6.....      | 47 |
| Figure 62 Illustration of placement of fault generator for thruster 1 .....                              | 47 |
| Figure 63 Current in DC fault generator at the ext. DC bus with fault in DC bus, eng. 6 and thr. 1 ..... | 48 |
| Figure 64 Current, Voltage and power at generator with fault in DC bus, engine 6 and thruster 1.....     | 49 |
| Figure 65 Current through Rectifier with fault in the DC bus, engine 6 and thruster 1.....               | 49 |
| Figure 66 Current through N-point of generator with fault in the DC bus, engine 6 and thruster 1....     | 49 |
| Figure 67 Voltage at Siemens DC bus with fault in the DC bus, engine 6 and thruster 1 .....              | 50 |
| Figure 68 charging current in battery with fault in the DC bus, engine 6 and thruster 1 .....            | 50 |
| Figure 69 Voltage at the external DC bus with fault in the DC bus, engine 6 and thruster 1 .....         | 51 |
| Figure 70 Current through external DC feed with fault in the DC bus, engine 6 and thruster 1 .....       | 51 |
| Figure 71 Current in converter 6 with fault in the DC bus, engine 6 and thruster 1 .....                 | 52 |
| Figure 72 Voltage measurements at engine 6 with fault in the DC bus, engine 6 and thruster 1 .....       | 52 |
| Figure 73 Current, Voltage and power at Engine 6 with fault in the DC bus, engine 6 and thruster 1       | 53 |
| Figure 74 Current, Voltage and Power on thruster 1 with fault in the DC bus, eng. 6 and thruster 1 .     | 53 |
| Figure 75 Current in converter 1 with fault in the DC bus, engine 6 and thruster 1 .....                 | 54 |
| Figure 76 Current in converter 2 with fault in the DC bus, engine 6 and thruster 1 .....                 | 54 |
| Figure 77 Current in Converter 4 with fault in the DC bus, engine 6 and thruster 1 .....                 | 54 |
| Figure 78 Illustration of the working principle of the IMD relay.....                                    | 57 |
| Figure 79 Illustration of Bender ground fault location system [7] .....                                  | 57 |
| Figure 80 Illustration of ground locating scheme where system can precisely locate fault .....           | 58 |
| Figure 81 Illustration of the least amount of transformers for the system to act on ground fault .....   | 59 |

## Tables:

|   |    |
|---|----|
| Table 1 Overview of Annotations used in all Graphs .....                      | 17 |
| Table 2 show when different faults in different components are generated..... | 39 |
| Table 3 Loading and setup of converter algorithm .....                        | 39 |

## Acronyms

|                 |   |
|-----------------|---|
| OCV             | Offshore Construction Vessel                                  |
| IT              | Grounding system (see chapter 2.3 for more info.)             |
| TT              | Grounding system (see chapter 2.3 for more info.)             |
| TN              | Grounding system (see chapter 2.3 for more info.)             |
| EMS             | Energy Management System                                      |
| DG              | Diesel Generator  |
| DPS             | Dynamic Positioning System (see chapter 2.2.3 for more info.) |
| THD             | Total Harmonic Distortion                                     |
| BlueDrive PlusC | Siemens DC-grid solution                                      |
| IGBT            | Insulated Gate Bidirectional Transistor                       |
| LV              | Low Voltage   |
| HV              | High Voltage  |
| GLL             | Generator Load Limiter  |
| GPU             | Generator Protection Unit                                     |
| IAS             | Integrated Automation System                                  |
| GPA             | Generator Power Adaption                                      |
| AVR             | Automatic Voltage Regulator                                   |
| ASD             | Adjustable speed drive  |
| DNV             | Det Norske Veritas (Company)                                  |
| DGPS            | Differential Global positioning system                        |
| FPSO            | Floating Production Storage and Offloading                    |
| RCD             | Residual-Current Device (ground fault breaker)                |
| IMD             | Insulation Measurement Device                                 |
| IEEE            | Institute of Electrical and Electronics Engineers             |
| RMS             | Root Mean Square  |
| Avg.            | Average   |





# 1 Introduction

The introduction of Shipboard DC power distribution represent an important change towards more environmentally friendly ships. The DC technology allow the generators to run at optimal speed instead of fixed non-optimal speed as the conventional AC system. Introduction of energy storage devices are also simplified in this distribution system.

The introduction of this technology is challenging since there are only a few vessels using this type of technology. The operational experience of this distribution technology is therefore limited. Some of the most challenging areas is the protection of large fault currents such as short circuits or second ground faults. Previous ships designed by Siemens utilizing DC distribution is mostly OSVs or ships where the components connected directly to the main DC bus where generators or large loads. These components are rigid and the chance for a ground fault to occur is small.

In the Offshore Construction Vessel where Siemens is designing and delivering the main power distribution, the number of components connected to the system is drastically increased. In addition to the generators, propulsion system, thrusters and other large loads connected to the main DC bus, a DC feed supplies an external DC bus connected to cranes, pumps and other equipment delivered by other companies. Loads connected to the external DC bus can be as small as only some tens of kilowatts. Equipment of this size is much more exposed for ground faults than large loads. This is because large components are designed and tested for larger fault currents and voltage peaks.

In a DC system, the chance of a second ground fault causing large fault currents is much higher than in an AC system. This is because there are only a few power transformers in the DC systems that create a galvanic separation between the different components in the system compared to in an AC system.

A concern of how the first ground fault will affect the system is set forth. Uncertainty of how the first ground fault will change the voltage between phases and between phase and ground on the DC bus and further to the AC side of other inverters is of special interest. In addition, how the changed potential affects batteries and other components in the system is of interest.

In Shipboard DC distribution systems used in OSV or other ships, a ground detection device is used in order to detect when a fault occur. The detection system sounds an alarm notifying the operator that a ground fault is detected. Then the operator can decide if the bus-tie breaker should be opened immediately or if it should stay closed. An evaluation of what action the system needs to do in this kind of system need to be performed. Should the system automatically locate the fault, or only detect the fault?

Today several localization techniques can be used in order to localize a ground fault in a system. Most of these techniques are however designed to operate in larger land based systems with long line distances and without substantial portion of power electronic converters connected. A study of the feasibility of these systems in short mesh like Shipboard DC distribution systems with several power electronic converters is needed.

In most AC distribution systems today, the IT grounding system is the preferred choice. This is because the nature of the system cause very small fault current. This further allows the system to operate normally even after the first ground fault have occurred. Since the experience with DC distribution systems is little, an evaluation of the feasibility of the grounding against other grounding systems should be performed.

## 1.1 Background

Until recently, DC-distribution in marine vessels has only been used in a few special cases like submarines and research ships. Submarines use DC-system because they utilize batteries or fuel cells when they are submerged, while research vessels use DC in order to reduce the noise from inverter modules and other components because of sensitive equipment on the ship [1].

Today several companies are developing and testing ships with DC-distribution. The reason for this is that the DC technology present possibilities for substantial fuel saving. This in turn makes the ships become more environmentally friendly. DC-distribution also save a lot of space and weight in the ship. The technology can be combined with energy storage units such as batteries or fuel cells [1]. A previous specialization report takes a closer look at the benefits and challenges of DC distribution in marine vessels [1].

This report is based on a specific relevant ship where the power distribution system is designed and delivered by Siemens Marine in Trondheim. The ship is a DPS-3 ship, meaning that the ship needs to fulfill special requirements (see chapter 2.2.3 for more information). In order to meet the demands of the class requirements, the ship need four separated busses. Siemens deliver all power distribution components, generators, and large loads connected to the main DC bus. This bus is identified as the Siemens bus in this paper. The vessel in question is an offshore construction vessel (OSV), and is built by Østensjø shipping from Haugesund. OSV ships are connected to many different consumers, such as large cranes, pumps and cable deployment equipment. External companies may deliver the components used in this equipment. The number of different consumers is very large, and the variety of size in the components is much higher than in an OSV. The external distributors and the Siemens bus is connected together with a DC-feed. One of the main advantages with this solution is that it gives the system the ability to feed power generated from equipment at the external DC bus back to the main power distribution bus. This can be from decelerating cranes or cable deployment system that need to hold back the cable. The power from the decelerating equipment can in turn be stored in batteries or used instead of a diesel generator. This will in turn saves fuel and emissions. One of the challenges with this solution is that since there is no power transformer separating the main Siemens bus and the external bus, a ground fault in a component on the external DC feed will propagate throughout the entire connected DC system. This means that a fault on a small component connected to the external DC feed threatens the entire system, meaning that a second fault anywhere else in the system will give a large fault current and potentially damage the power electronic components connected to the DC bus.

This report is set forth in order to analyze how ground faults in different places in the system affect the normal operation. The focus of this task is towards how the first ground fault affects the system. Also a proposed solution of how the system should detect and handle a fault situation in order to avoid or reduce the chance that a second ground fault can appear. A short analyze of what type of grounding system is most feasible is also performed.

## 2 Theory

### 2.1 Introduction:

The thesis is investigating how ground fault will affect a specified ship under planning at Siemens Marine in Trondheim. The ship is designed with a DC power distribution bus technology called BlueDrive PlusC. The introduction of this system introduces many new challenges compared to conventional AC distribution. The ship is also designed to fulfill the requirements of DPS-3 class ships. The report explains the basics of what this involves considering the design and planning of the power distribution system. The report includes an evaluation of what type of grounding system is most useful in helping the system obtain operational reliability and explains the main difference between how ground faults behave in an AC system compared to in a DC system. Short explanations of different techniques of detecting and locating ground faults in AC and DC distribution systems are presented. The last chapter of the theory part discusses how system protection is done in this type of distribution system.

### 2.2 Dynamic positioning

This chapter gives a basic instruction of what dynamic positioning is, and how it is used in a ship. The requirements of the power distribution system and components with relation to reliability and redundancy are also presented.

Dynamic positioning technology is widely used in deep-water exploration and production drilling. The technology can be used in many types of vessels. Among other; offshore supply vessels, offshore construction vessels, FPSO, underwater cable and pipe laying vessels, flotels, survey ships, cruise ships, diving support and many more. [2]

#### 2.2.1 How it works

The main function of a dynamic positioning system is to maintain the position and heading of a vessel at the desired position. In order to do this, the ship needs to generate forces that counteract the environmental forces such as wind, waves and current. The ship uses thrusters, propellers and rudders in order to counteract these forces. The most important component in dynamic positioning is the thrusters. The system needs several sensors in order to allow automatic control of positioning and heading. In order to accurately know the position of the ship, several reference systems are used. The heading of the ship, however, is provided by the gyrocompasses. [2]

The vessel has six freedoms of movement. The DP system can compensate for three of these movements. These three movements can be seen in Figure 2, and are surge, sway and yaw. Surge and sway define the ship's position while yaw constitutes the ship's heading. [2]

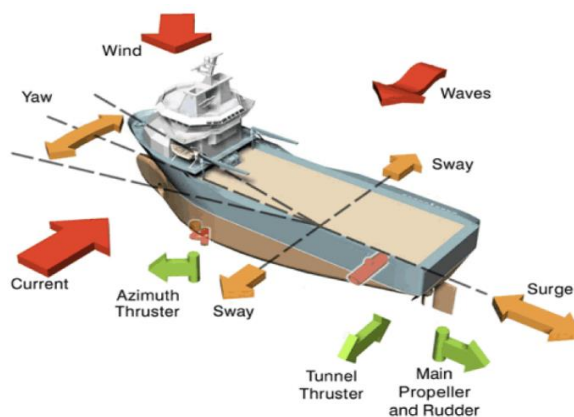

Figure 2 A ship's freedoms of movements and forces

Environmental forces acting on the vessel are known for their variability. Because of this, the power demand needed to counteract these forces will change dynamically. A loss of electricity will lead to loss of the dynamic positioning functions of the vessel. Because of this, the reliability of the power system in DP vessels are very important. The power system consist of power distribution, power generation, power control and safety systems. There are several configurations and different levels of complexity of power systems depending on type of vessel and requirements of DP system. [2]

The sensors main role is to measure vessel heading, movement and external forces acting on the vessels. The different sensors are gyrocompasses, vertical reference sensors and wind sensors. In addition, other forces are calculated by deducting directly measures forces from forces generated by thrusters. Different types of reference systems can be used to determine the position of the vessel. Common for the reference systems is that each reference system provides position reference relative to a known reference point. The reference origin can be DGPS system underwater transponder or fixed transponder on FPSO. Computers gather signals form sensors and position reference systems. The system then instantly calculate the forces needed to counteract the external forces and keep the pre-defined position. [2]

### 2.2.2 Redundancy

Redundancy in dynamic position is defined as the ability to maintain the vessels position and heading upon a single failure on any component within dynamic positioning system. Normally this means a duplication of components performing a required function, or providing backup capability capable of provide bump less recovery after a failure on the main system. Different ships are built to different standards and operations. The criteria relating to level of redundancy required in a vessel is defined by the level of risk associated with the operation. The greater the hazard associated with the operation and worksite location, the greater the level of redundancy should be. DP vessels are built to satisfy worst-case scenario faults. Design intent is related to the type of operation or particular character requirements. In most AC power distribution systems, redundancy is based on the concept of spinning reserve in running diesel engines. This makes the engine operate on a low efficiency level. [3]

### 2.2.3 Classification and Requirements

There are three main dynamic position classes:

- DPS-1 (IMO class 1)
- DPS-2 (IMO class 2)
- DPS-3 (IMO class 3)

In basic terms class 1 refers to a vessel without redundant capability. In the event of a single fault, the ship may lose its position and heading. Class 2 relates to vessels with full redundancy of systems and equipment. In this class, the vessel should not lose its position or heading due to a single fault in active components or system. Vessels designed with class 3 requirements should be able to withstand the loss of all systems in any one compartment in the event of a fire or flooding without losing its position or heading. Traditionally the DP class notation only accept redundancy based on running machinery, and do not accept redundancy based on standby start of generators, batteries or other energy storage devices. Consequence analysis is a tool required to be incorporated in DP systems with built-in redundancy (class 2 and 3) This is important in order to continuously perform analysis of the vessel's ability to keep its position and heading in the event of the worst possible failure. [3]

## 2.3 Grounding system

In AC power systems, there are three main ground systems used today. The three systems offer different advantages and challenges. It is important to apply the correct type of grounding system considering the area of use. The three main systems are:

- TN – Terra Neutral
- TT – Terra Terra
- IT – Isolated Terra

The two letters indicate respectively the connection between earth and the power supply (generator or transformer), and the connection between earth and the electrical load.

### 2.3.1 TN System

The TN system is split into three main parts. The three systems are:

- TN-S. In this system, the Protective Earth (PE) and Neutral (N) conductors are connected together near the power source. The power is led to the consumer in two separate conductors. This standard is mostly used between the main switchboard, to sub stations and from the power source to substations.
- TN-C. In this solution the protective earth and neutral is combined in one conductor called PEN conductor. This solution is rarely used close to the load. It can only be used in special situations.
- TN-C-S. This system is a combination of the two previous described systems. It uses a combined PEN conductor as supply before the distribution switchboard. In the switchboard, the PEN conductor is split into the PE and N conductor.

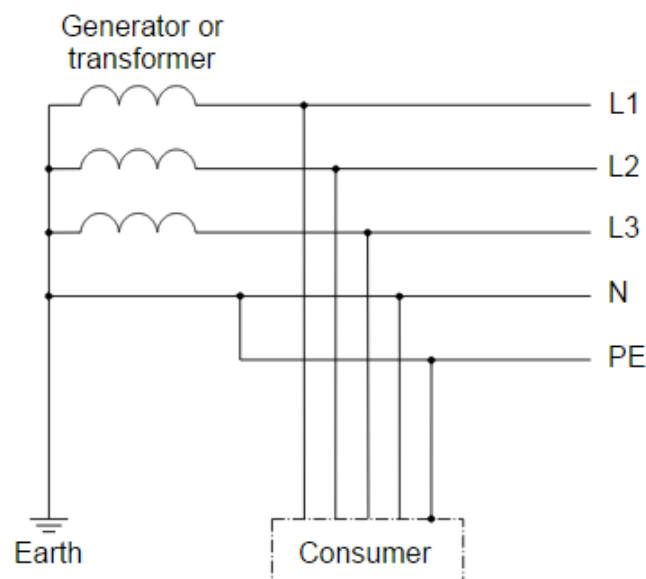

*Figure 3 TN-C-S grounding system*

Figure 3 show the structural buildup of the most common TN system, the TN-C-S grounding system. The main advantage of the TN grounding system is that it gives the opportunity to operate with a higher voltage between phases. This is because the N conductor gives the ability to exploit the voltage between the phase and the neutral point of the generator. The construction cost in a TN system is cheaper because the high voltage level cause a reduction in current at the same power output. This further reduce the need for large cable sizes.

When a ground fault occur in a TN system, the fault current will rise to the same current amplitude as a short circuit between the phase and neutral conductor. This is because the ground resistance between phase and ground equals the same resistance as between phase to the neutral point of the power supply. The voltage potential between phase and ground is the same as the voltage potential between phase and neutral. The weakness of this system is that loads need to be disconnected at the first ground fault.

### 2.3.2 TT System

In the TT grounding system, the protective earth at the power supply is connected directly to ground from its neutral point. There is however not a conductor that connects the neutral point of the power supply directly to the consumers. The consumers are connected to ground independently from the power supply. This causes the fault impedance to become higher than in a TN system. The impedance is however not high enough to avoid the requirement of residual-current device (RCD also called ground fault breaker) at its first ground fault.

The biggest advantage of the TT ground system is that it is clear of high and low frequency noise from the neutral conductor. Because of this, TT systems are preferred for special installations like telecommunication that benefit from the noise-free grounding. Figure 4 show the structural buildup of a TT system. It can be seen from the figure that the neutral point has been carried out with a neutral point separated from the grounding that is locally connected to ground in both ends.

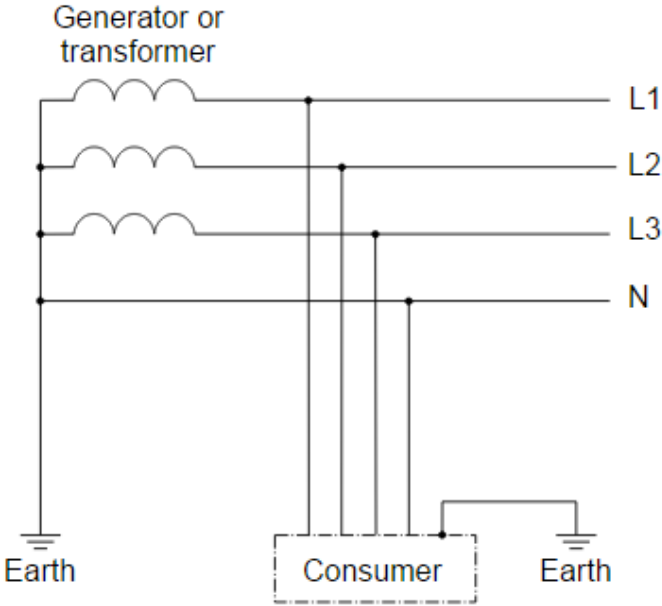

Figure 4 TT-grounding system

2.3.3 IT System

The IT system have a great advantage compared to the other two systems. This type of grounding system is able to operate indefinitely with a ground fault on one phase. This eliminates the need for an immediate shutdown if a fault occur. When this system is operating in dynamic position, or other critical operations, the system can still operate until the fault can be cleared at a more convenient time. In an offshore ship, this is an important feature giving the opportunity to operate the ship normally at the first ground fault. The IT system is the only system where RCDs is not a requirement.

The biggest problem with this system is that it may be difficult to locate and clear a ground fault when it occurs. It is however important to clear the ground fault as soon as possible in order to avoid a second ground fault on another phase anywhere else in the same system. If a second fault occurs on another phase, the fault current can be considered the same as in a short circuit. Figure 5 Show the principal buildup of an IT grounding system. It can be seen that the power supply have no grounding in its neutral point [4].

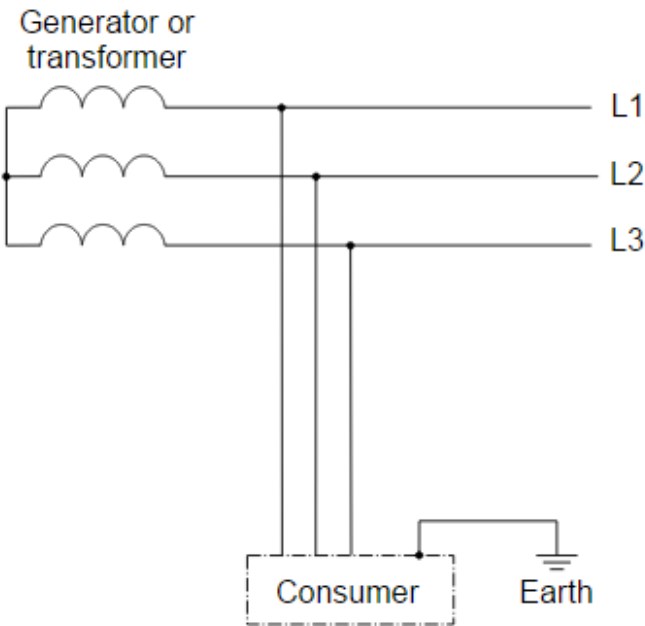

Figure 5 IT grounding system

## 2.4 Ground fault in DC power systems compared to AC power systems

Ground faults in AC and DC power distribution is fundamentally the same. A ground fault is a connection between a phase and the electrical ground potential. However, DC systems represents some new challenges compared to the conventional AC system.

If a one phase to ground fault occur in an AC distribution system, a second fault in the same phase somewhere else in the system will not give large fault currents. This is only correct as long as the fault occur on the same side at the same transformer as the first fault. Large fault current will only occur if the fault have occurred in another phase connected to the same power supply as the first fault. If the same phase have a connection to ground in two different places, the potential between the faulty phase and ground is unchanged at the second fault. The fault current will not change noteworthy. If however a second fault occur in a different phase than the first, the second fault make a phase-to-phase short circuit, with a fault current almost as big as a short circuit fault current.

In a DC distribution system, ground faults one place in the system will propagate throughout the system and affect the voltage potential between phase and ground everywhere else in the system. This can be demonstrated by the following example. If a ground fault occur on phase a of one inverter, this fault would propagate to the AC side of all other inverters. If a second ground fault then occur on phase a (the same phase) of another inverter, the fault current would still be very large. In addition, a second fault on the DC side of the inverter will act as a short circuit with a large current ripple. This is because DC voltage from an AC/DC rectifier, consist of all three phases melted into one. The inverter then creates AC voltage by chopping the DC voltage. As long as the inverters are not 100% synchronized in their algorithm, phase a of one inverter will not contain the exact same voltage potential between phase and ground as the other. This fact gives the DC system a larger probability of large fault-current when the second ground fault occur.

Another important difference between ground fault behavior in AC distribution systems and DC distribution systems is that most large consumers in an AC system is separated from the main AC bus by a power transformer. The transformer in an AC system have several main tasks. It reduces the TDH when connected to a variable speed drive (this is used for almost all thrusters and large propulsion loads in modern ship). In some cases where the bus have higher voltage than the load, the transformer reduce the voltage level. Another positive side effect caused by the power transformer is that it gives a galvanic separation between the bus and the consumer. This means that a fault current is not able to propagate from one side of the transformer to the other. In this way, a fault in one load will not affect another fault in the bus or other places in the system. Because of this, the probability of a second ground fault with large fault current is drastically reduced.

## 2.5 Different categories of ground faults

**Constant ground fault** – This type of ground fault is the most common fault, and is the easiest to detect and locate. The fault occurs, and stays at the same level, or it increases[5].

**Intermittent ground fault** – This type of fault comes in and out with relatively long periods of more than five minutes in either fixed or random off period. This type of fault can be harder to find, since it is periodical. It is however possible to detect with standard ground fault detection equipment [5].

**Transient ground fault** – This fault type is separated into two sub-categories: “Pulses” and “Spikes”. Pulses have a short (0.5 – 5min [5]) duration in with either a fixed or random off period. Spikes are very short (0.01 – 5 min) with an either fixed or random off period [5].

This report does not separate between the different categories of ground fault when simulating or planning how the system should handle faults.



## 2.6 Methodologies for locating ground faults

Several different methodologies for locating ground faults can be used. Some of the different techniques are more useful than others, but all of them have different limitations, capabilities and interactions with the system.

**Voltage measurement** – This is a fault detection method done by monitoring the voltage between the phases and ground. In any case, where the values between the phase and ground collapse to zero, a fault have occurred somewhere in the system. This technique can easily help you detect if there is an earth fault in the system. It is however not able to tell where in the system the fault have occurred. This technique is very suitable in order to monitor the state of the system.

**Selective tripping, isolation** – This fault localization technique is used in combination with voltage measurement, where parts of the system is isolated one-step at the time until the fault disappear. When the fault disappear the faulty circuit has be found. This method is however only able to locate the faulty circuit and components that can easily be unplugged. The method is feasible in small systems where disconnection of parts of the system is possible. In larger systems, considerable amounts of time can be required to locate the fault. Opening and closing of disconnecting devices may also inadvertently trip/interrupt other circuits in the system.

**AC signal injection** – This method will locate faults, while minimizing circuit and service interruptions. The technology requires high system knowledge due to the effects the injection of energy into your system can have on the system. The technology tends to be ineffective in multi-feeder distribution systems having large stray capacitances and/or large “E” field interference between the distribution line and ground. In order to overcome the low impedance to ground, a large AC signal is required. The use of large amplitude AC signal may trip or damage sensitive devices or circuits.

**DC signal injection** – Locates faults, while minimizing circuit and service interruptions. High system knowledge is needed due to the effects the injection of energy into the system may have. Current through ground faults must be monitored and controlled so not to inadvertently cause actuation of faulted device, especially on multiple ground fault scenarios. The use of large amplitude DC signal may trip or damage sensitive devices or circuits.

**DC interrupts** – Locates faults, while minimizing circuit and service interruptions. High system knowledge is needed to understand the obtained results. Uses magnetic coupling of the fault current to locate the fault. The ground fault current can be controlled and monitored so not to inadvertently cause actuation of faulted device. This technique can be used on both energized and de-energized circuits. They are able to accommodate a large range of cable and conduit size.

**Event analysis** – This approach is able to detect transient ground faults. The use of this technology entails the use of several event recorders and current transformers, which are being placed around in the system in a way making them have the best coverage of the system. The technology then monitors the system and records any events in the system. The result then needs to be analyzed in order to pinpoint the fault location. In very large systems, it is not always feasible to monitor the entire system. If an event has not been recorded, the equipment then needs to be moved to a different part of the system for further surveillance. This process can in large systems take much time and be very costly [5].

## 2.7 System protection

### 2.7.1 Protection of ground faults

Since the first ground fault in an IT system is very small due to the lack of grounding in the neutral point in the power supply, it is not required to disconnect the first ground fault in an IT power system. It is however required to have detection of the first ground fault. When a ground fault is detected, it is important that the ground fault is cleared as soon as possible in order to reduce the probability of a second ground fault. The process of detecting exactly where the ground fault have occurred is usually done manually and often parts of the system need to be de-energized in order to accurately locate the fault.

### 2.7.2 Requirements for short circuit system protection

If a second ground fault would occur in an IT power system, the fault current of the second fault can become very large and can be considered to have the same magnitude as a short circuit. In the event of a second ground fault, the fault current is handled by the same protection scheme that protects against short circuit fault currents.

The circuit breaker traditionally has three main functions:

- Automatic protection against electrical faults triggered by overcurrent.
- Physical isolation of a circuit, enabling safe access to de-energized circuit
- The possibility to easily connect and disconnect consumers according to need.

Breaking a fault current in a DC-system is much more complicating than in an AC-system. This is because, in an AC system the current have a natural zero crossing that makes it easier to break the current when it hits zero. For DC-current, the breaking capability in conventional breakers is very much reduced. Using traditional circuit breakers to interrupt faults in a DC system is therefore not feasible. [1]

When a fault occurs in a ship distribution system, the fault current often reach the range of 50.000 to 100.000 Amperes. The reason for this very large short circuit current is that the converters connected to the system contains very large capacitor banks that in the case of a fault will discharge. Conventional DC circuit breakers for this kind of current hardly exist and are too big, heavy and costly to use in a ship distribution system. [1]

The solution used to solve this problem is to replace the traditional circuit breaker with semiconductor devices in series with a conventional melting fuse and so called "system protector" schemes. By introducing this technology, the circuits are no longer physically separated unless the fuse is melted. The demand for physical separation from an energized part of the system is absolute in order to be able to work on components in the system. [1]

In order to meet the demand for physical separation, a service breaker need to be in series with the semi conductive breaker and fuse. This breaker is not designed to be operated while energized. It is therefore important to be sure that there is no current flowing through the service breaker when it is opened. A safe and reliable operation of the service breaker is seen as a basic requirement. [1]

Easy manual operation for connection and disconnection of consumers in a system with semiconductor breakers is a challenge. This is because the switching is dependent on control systems for the semi conductive units. A robust system with local control units independent of a centralized control system is required. [1]

### 2.7.3 Working principle and challenges with semiconductor based current interruption

Semiconductor circuit breaker use the same principle of controlling the power as transistors do in electronics. However, the semiconductors in power electronic breakers are able to intercept large currents and relatively high voltage. [1]

While the conventional AC breakers achieves current interruption by mechanical separation of two poles, the semiconductor breaker use a semiconducting metal to achieve isolation between the poles. The switching is done by sending an electric control signal to one of the silicon layers in the unit. [1]

In conduction mode, the semiconductor is a fairly good conductor. However, it is less conductive than copper, resulting in bigger losses through the conductor. Therefore, it is important to cool down the semi conductive part of the breaker. This is done by circulating water in the unit. [1]

There are three main challenges with semiconductor switches:

- Interrupting capacity

The interrupting capability of the AC-switches are well known through years of experience and well established tests, while semiconductor breakers of this size is relatively new technology and have no established testing standards. Using semi conductive breakers to interrupt continuous load current is not a very big problem. The challenge is to be able to break short circuit currents. [1]

- Control system integrity

While AC circuit breakers are mechanical devices that can be operated manually, semiconductor switches need control signal to be operated. Therefore, a very reliable control system with emergency power supply is needed. Another criterion for this type of breaker is that it should be possible to operate locally in addition to the centralized control system. [1]

- Cooling system integrity

It is important to have good redundancy in the cooling system so that a fault in this system does not result in unavailability of more than one redundancy group. An eventual leakage in the cooling system must not jeopardize the primary side of the device because this will imply that a larger part of the system will be affected. [1]

### 2.7.4 Generator protection

The most serious faults that can occur in an electric system is a short circuit on the bus bar. A fault here is something one want to reduce as much as possible. In order to achieve selectivity, the generators will deliver short circuit currents for up to 0.6 seconds. In an AC system, the generators provide most of the short circuit currents, while the diode bridges in the converters block currents from the frequency converters. In a DC network however, the capacitor banks is discharged to the bus without any interruption, delivering very high short circuit current with a short rise time. The short circuit current from the capacitor banks will deliver enough current for a sufficient time so that the fuse closest to the fault will trip and clear the fault. The main generators are dimensioned with a short circuit impedance that will reduce the contribution from the generators. The main generators do not have any fuses; Because of this, the generators will deliver nominal current while a generator protection unit (GPU) will de-magnetize the generator and stop the diesel engine. During normal operations, a generator load limiter system (GLL) will protect against power overloads. [1]

A “multi protection generator relay” protect the generator from several faults. The protection system will protect against over voltage, Asymmetrical current (single diode fault), generator differential protection, generator over-current protection and de-excitation. Because the diodes will stop power from flowing from the bus to the generator when the bus is energized and the generator is inactive, there is no need for physical separation between the bus and the generator. An isolation switch is however placed in series, but is not designed to be operated as long as the generator is loaded. It is therefore closed (connected) during normal operations. [1]

#### 2.7.5 Protection of drives

Every drive in the system will have a DC fuse in series in order to protect each drive from overload and short circuit. If a short circuit occurs on the DC side, a rush of current from the capacitor banks of all the other drives and current from the generators will cause a current large enough to trip the fuse. Selectivity is kept by dimensioning the fuses large enough so that they can handle the discharge current from the connected drive, but not the combined current of all other drives. If the fault occurs on the motor side of the drive, the inverter module detect the un-normal current pickup and open the IGBTs in order to clear the fault. Since the IGBT response time is very fast, it may clear the fault before the fuse is tripped. [1]

#### 2.7.6 Bus-tie breaker

The bus-tie breaker is an essential component of a shipboard power system, as it is the link between the two separate parts of the power system. The system is split in two at all the different voltage levels. The reason for splitting the system in two is to have good redundancy. In any case of electrical fault, at least 50% of the system should be able to operate normally. In normal operation, it is an advantage to be able to operate the system with a closed bus-tie in order to improve the stability of the system and to operate with a more optimal number of generators in relation to the loading.

In case of a fault, the short-circuit current will flow from the healthy bus, through the bus-tie breaker to the bus containing the fault. The IGBTs in the bus-tie breaker needs to be able to handle a much larger fault current than the IGBTs in the inverters. The design of the bus-tie breaker therefore needs to be chosen with a much higher rated capacity than the expected current flow during normal operations. [1]

The reason for using IGBTs in the bus-tie breaker instead of a normal circuit breaker is to meet the demands mentioned above. IGBTs are able to act at a remarkable speed allowing it to stop the fault current before it has reached its maximum value. Because of the short rise time of the capacitor-banks, it is preferred to increase the inductivity in the system in order to prolong the rise time. This is achieved by having a choke in the system that helps the IGBT based bus-tie breaker opening the circuit. Snubbers are used in order to reduce harmful voltage spikes in the system caused by the opening of the bus-tie breaker in normal or fault situations. [1]

In a situation where the bus-tie breaker has been opened and is going to close again, the bus-tie has different challenges compared to a bus-tie breaker in an AC system. In the AC-system, the two busses need to be synchronized to each other. In a DC system, this is no restriction. The only limitation is that the voltage difference between the two busses should not be large. A pre-charge circuit is used to avoid a large inrush current when connecting the busses. If the system is closing the bus-tie breaker between one energized bus and a “dead” bus, the pre-charge circuit needs to be used in order to avoid a large rush of current through the bus-tie breaker caused by the charging of the capacitor banks in the dead system. The magnitude of this current would be very large without the pre-charge circuit. The choke in the bus-tie breaker is also used to reduce the current rise time [1].

## 3 Modeling the Shipboard DC power system

### 3.1 Designing the model

A Matlab/Simulink model of a bus in the relevant project at Siemens has been designed. The model represents one of four busses in the shipboard power system in question. The model has been simplified compared to the actual bus in the ship. The simplification is considered representative since most of the important components are included. The introduction of more components is not considered to have an effect on the fault simulations. An important part of the model is the external DC bus. An external DC feed connects the external DC bus and the Siemens bus together. The external DC bus is connected to loads that varies largely in size and build quality compared to the large loads on the Siemens bus. A fault is therefore more likely to occur in components connected to this external bus.

#### 3.1.1 The principal buildup of the model

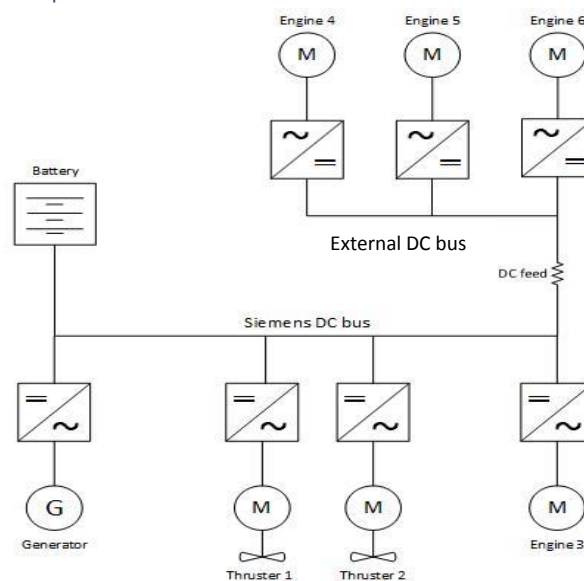

Figure 6 Single-line diagram overview of the studied shipboard dc hybrid power system

Figure 6 shows the simplified bus of the ship that is being designed by Siemens. As a part of the DPS-3 requirements, the actual ship contains four of these busses. The system on the ship is an IT-system, meaning that the neutral point of the generator is isolated from ground. This is important information when analyzing how a ground fault behaves in the system. The bus can be split in two main parts:

- **The Siemens DC bus**, which is directly connected to the generators and the largest consumers like thrusters and propulsion. Siemens supply all components for power distribution and power electronics connected directly to this bus. The bus is also connected to a battery in order to help the generators run more stable (The battery itself is not delivered by Siemens).
- **The external DC bus** is connected to the Siemens bus through a DC feed. This bus can be connected to power electronic components delivered by other manufacturers than Siemens. The connected components on this bus vary largely in size compared to the components on the Siemens bus. In the simulation model, the largest load connected to the DC-feed is 800kW, while the smallest is only 30kW. While the large converters are made rugged with good isolation capabilities in order to handle faults, the smaller inverters are cheaper and less tolerant to voltage spikes or other events.

### 3.1.2 Simplifications and assumptions

Several simplifications have been made when designing the simulation model. This is done in order to reduce the complexity, and increase the reliability of the results. The generator is modelled as a voltage source with a constant supply of 690V RMS AC at 60Hz. Further, the loads are replaced with RL loads with a fixed active and reactive load flow. All values of the components in the system are presented in Appendix C. The neutral point of the voltage source cannot be left as an open circuit. The neutral point is therefore connected to ground via a resistance of 1000Mohm. This is considered large enough resistance to be considered as an isolated system. The lack of dynamic capabilities in the model is expected to affect the models ability to simulate second ground faults. This is because the first ground fault does not have a large fault current. The results are expected to be similar in a dynamic model as in this simplified model. The issue with getting the dynamic model stable is more likely to affect results negatively, and make them less reliable when simulating the first ground fault. When simulating second ground faults however, the simplified model will not give realistic results. It can however help give an indication on the effect it would have on the system.

For some of the components some assumptions have been made:

- Due to lack of droop characteristics in the voltage source, the battery charge is set to about 50%. This is done in order avoid large discharge currents from the battery to the bus. In the case with a dynamic generator, the voltage on the bus will rise when the load is low, further charging the battery to its nominal voltage. Battery data is found in Appendix A.
- Capacitor banks are based on standardized sizes given from Siemens, where the smallest bank is set to be 21mF. This value cannot be smaller in order to ensure that the fuse melts in case of a fault on the bus. The largest capacitor banks are 42mF and are connected to the thrusters. This bank consists of two 21mF banks connected in parallel (See Appendix A).
- Converters are defined as ideal semiconductor switches
- Buses are ideal and have no resistance or inductance between terminals.
- Standard nominal frequency of generator and inverters is set to 60Hz, unless the text tells otherwise.
- All cable values are calculated from given values in table 18 in appendix B. The cable size are chosen from table 52B-8 using method G in NEK 400 based on calculated current through each cable. Since the table is limited to cables up to  $3 \times 240 \text{mm}^2$ , the values of the largest consumers are calculated with the use of several cables of the same size. Example: the cables for the thrusters are calculated from four parallel  $3 \times 240 \text{mm}^2$  Cu cables. The line-line capacitance is not calculated mathematically. The assumed values of the cables are expected to affect the results to a very small degree. Especially in simulations of first ground faults.
- The Values of the DC feed cable have been calculated based on values given by Siemens. Values are specified in Appendix A and calculated with 50-meter length.
- The converter controls is not able to consider actual voltage, and is not set to output a specific voltage. It will therefore not compensate for any voltage changes on the bus or the AC output voltage. Algorithm is defined manually at simulation start and does not change throughout the simulation.

The introduction of power electronics in the shipboard power system provides several benefits, but also introduces more complexity than systems based on conventional AC based power distribution. This is due to the switching behavior of the semiconductors and the nonlinear properties of the power converters. In this simulation model, the focus is how ground faults behave in the system. The dynamic behavior of the generator and loads are not considered.

### 3.1.3 Structural buildup of the MATLAB Simulink model

Figure 7 show how the system where designed in Matlab/Simulink. The generator is simulated as a voltage source that supply a stable voltage of 690V 60Hz. The loads are set to be resistance and inductance in series with a pre-defined power consumption for each given load. The size of the loads are decided in collaboration with Siemens. It can be seen from Figure 7 where different measurements are placed in form of sub systems connected in series or parallel with the part of the system it is measuring. All sub systems are also connected to scopes in order to allow readings of the results.

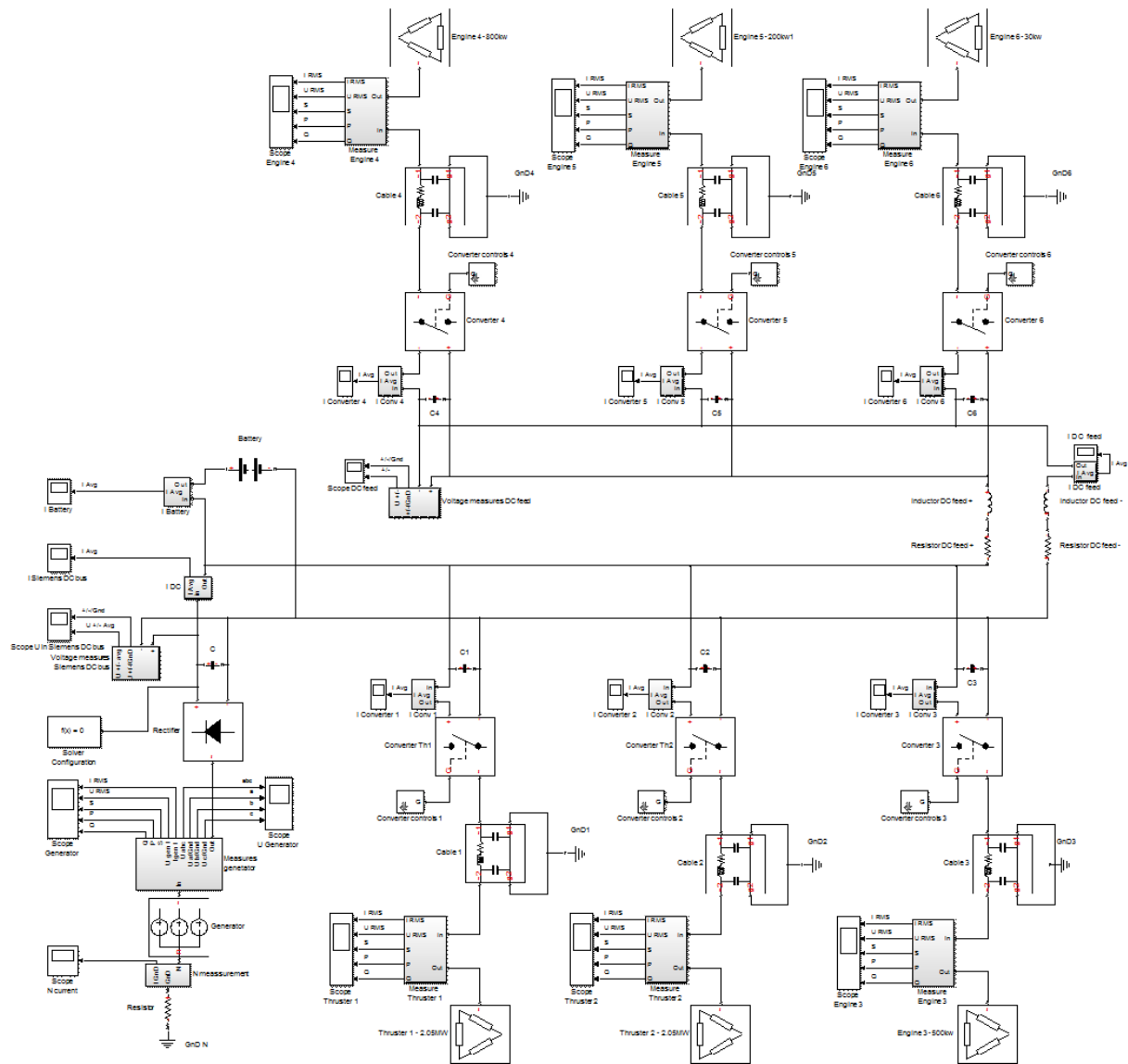

Figure 7 MATLAB Simulink model

Figure 7 show the structural buildup of the Simulink model. A larger version of the model can be seen in appendix D. In addition to the main components shown in Figure 6, the Simulink model have capacitor equivalents, cable equivalents and several sub systems designed with different measure parameters connected to scopes. All components in the model have been obtained from the Simscape library. The subsystems have been made in order to simplify the layout of the model. All components in the subsystems are also obtained from the Simscape library. The model is simulated by using the ode 23t solver in Matlab/Simulink. Some changes in the measuring blocks may occur as the need for measure results change during simulation and analyzes.

### 3.1.4 Sub systems

All loads are connected through different measurement systems. The generator is connected to two different subsystems, where one measure the current through the neutral point to ground and the other measure the RMS current, RMS voltage, the apparent, active, reactive power, the phase and combined 3 phase voltage from the output of the voltage source. On the Dc bus, a current measure block measure the DC output current from the rectifier. Another block measures the DC voltage from positive and negative to ground, and between the two poles in real and average voltage. This system is used on both the Siemens and the external bus. All inverters, the battery and the DC-feed are connected in series with a current measuring block that outputs the average current consumed from the DC bus. In order to analyze how the current behaves, most of the ripple is removed by the use of a mean block in series with the output signal. On the AC side of each inverter, a measurement system outputs RMS current, RMS Voltage, apparent, active and reactive power. Power readings are made on only one phase in order to make it clearer. Subsystem buildup and values for the different sub systems can be seen in Appendix E.

There are two different fault generators used in the simulation. The fault generator used for AC faults is found in the Simscape library as "time-based fault". There has also been designed a measuring subsystem that is connected in order to analyze the fault current and voltage to the generated fault. When creating ground fault at the DC bus, a complete subsystem have been designed. The system uses a switch connected to a step signal with a time delay. When the signal is sent at a pre-defined time, the switch connects the phase to ground via a resistor with a pre-defined resistance. Information about the fault generators and their buildup can be found in appendix E. Some changes in the measuring blocks can occur as the need for different test parameters change during simulation and analyze.



### 3.2 Normal operation

The following chapter show how the model behaves during normal operations. All graphs are marked with what type of measurement is carried out over each graph. Table 1 show an overview of the annotations used in the simulations.

| Annotation | Description                     | Unit            | Annotation | Description              | Unit |
|------------|---------------------------------|-----------------|------------|--------------------------|------|
| I          | Ampere                          | A               | abc        | Volt between all phases  | V    |
| U          | Volt                            | V               | Gnd        | Ground                   |      |
| S          | Apparent Power                  | VA              | +          | Positive Phase on DC bus | V    |
| P          | Active Power                    | W               | -          | Negative Phase on DC bus | V    |
| Q          | Reactive Power                  | VA <sub>r</sub> | Avg        | Average                  |      |
| a,b,c      | Volt between each phase and gnd | V               | RMS        | Root mean Square         |      |

Table 1 Overview of Annotations used in all Graphs

#### 3.2.1 Generator

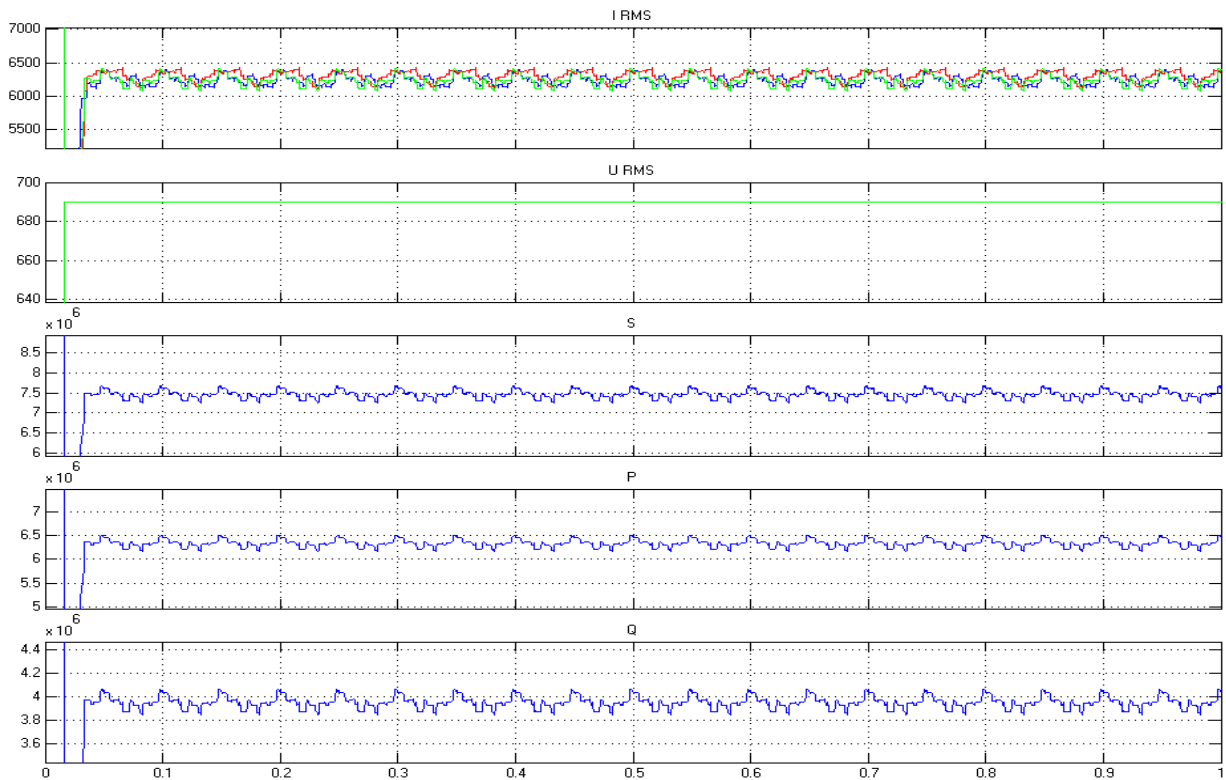
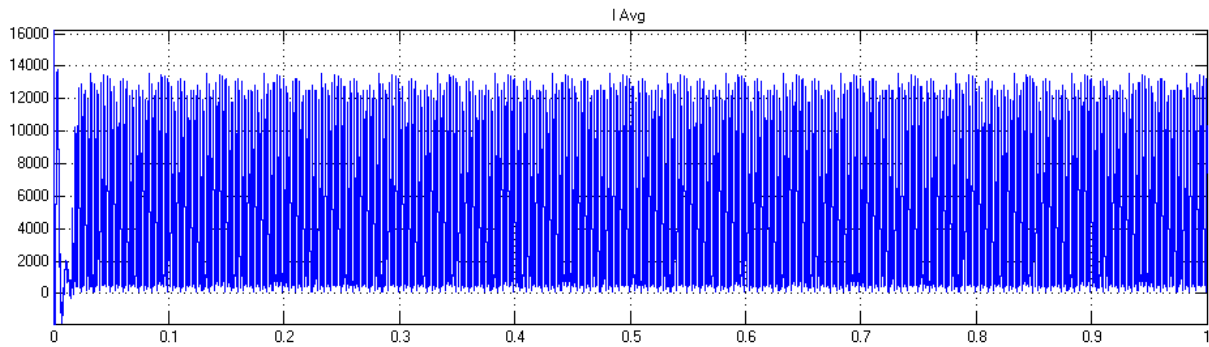

Figure 8 Current, Voltage and Power results from Generator measure block in normal operation

The RMS voltage of the generator equivalent has exactly 690 volts. This is because the generator has been replaced by a voltage source supplying a perfect sinusoidal RMS voltage of 690V at 60Hz. The voltage output is not affected by the load, and will not change in the case of a short circuit or other events. It can therefore be said that the generator equivalent is not dynamic. During normal operations, the generator outputs an average apparent power of about 7.5 MVA. The active power is equal to about 6.35MW. This equals a  $\cos \phi$  at about 0.85 for the sum of all loads, which is the selected  $\cos \phi$  value for all loads in the system. The active output power of the generator is however about 900kW larger than the sum of active power consumed by the loads. The reason for this is expected to be losses in cables, converters, rectifiers and charging of the battery. Large ripple currents on the DC bus and to the AC loads are creating unnecessary large losses in the model.

### 3.2.2 Siemens bus



*Figure 9 DC current on the output of the rectifier in normal operation*

Figure 9 show the actual current simulated on the output of the rectifier. The current from the rectifier have a very large ripple due to the combination of several large inverters and large capacitor banks connected to the DC-bus. The reason for this is that the voltage source used in the simulation has no inductance as a dynamic generator would. In a real dynamic system, the generator inductance would smoothen the current ripple. Since the bus is considered ideal, the inductive component in the bus that could help smoothing the current ripple is not present. In addition, the control algorithm for the inverters are completely the same in the simulation. This mean that all inverters switch between on and off at the same time. This created an unrealistic high current surge since the converters in an actual ship do not have the exact same control algorithm.

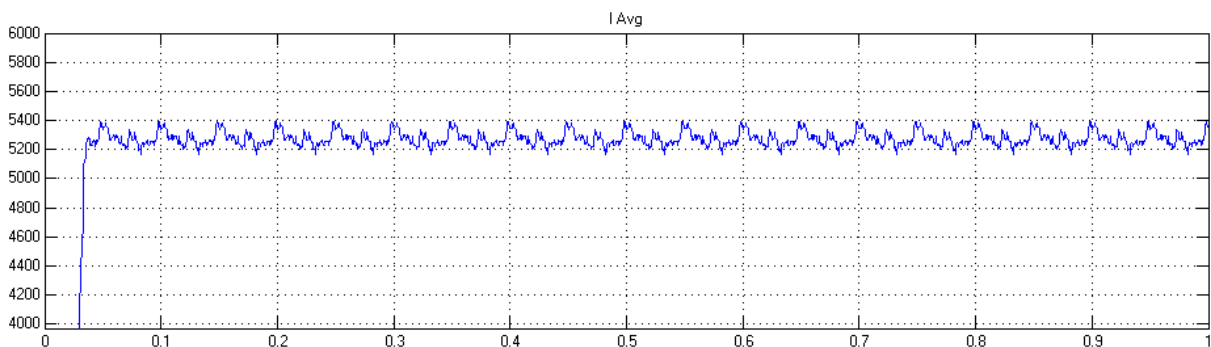

*Figure 10 Average DC current on the output of the rectifier in normal operation*

The large ripple current is present on most of the current measurements in the system. In order to easier analyze the system in an ground fault situation, the mean value of the current have been used in all current measurement blocs. Figure 10 show the average current output from the same current measurement system as showed in Figure 9. The voltage ripple on the DC bus cause the power consumption of the loads to increase and decrease in pace with the voltage ripple. This in turn results in the ripple in the mean current throughput of the rectifier.

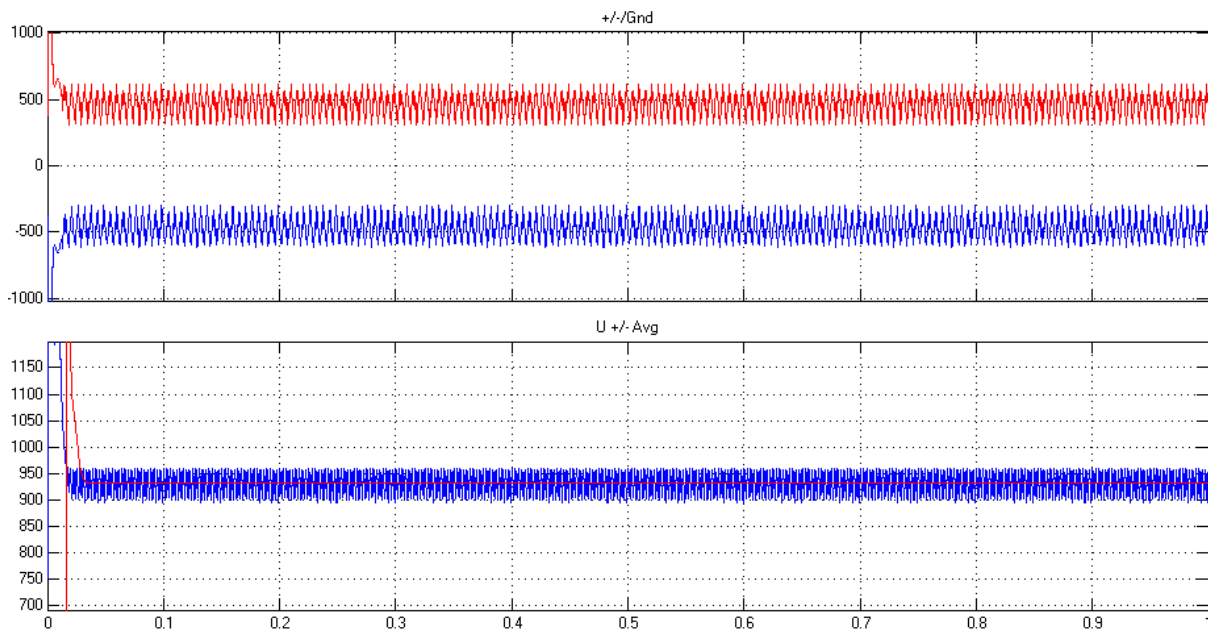

Figure 11 Voltage measurements on the Siemens DC bus in normal operation

Since the system is completely isolated from ground, the voltage between positive and ground, and negative and ground is about +/-465 volt in average. The ripple between each phase and ground is relatively big, with a voltage ripple of up to 300V. When the ripple is measured between the phases, it is however much smaller, about 60V from 960V to 900V and an average voltage of about 932V. The voltage ripple on the DC bus in a real system would be smaller since the inductance in the generator would reduce the ripple in current, further reducing the voltage ripple in the system. Filters can also be used in order to reduce the voltage ripple on the bus.

### 3.2.3 External DC-bus

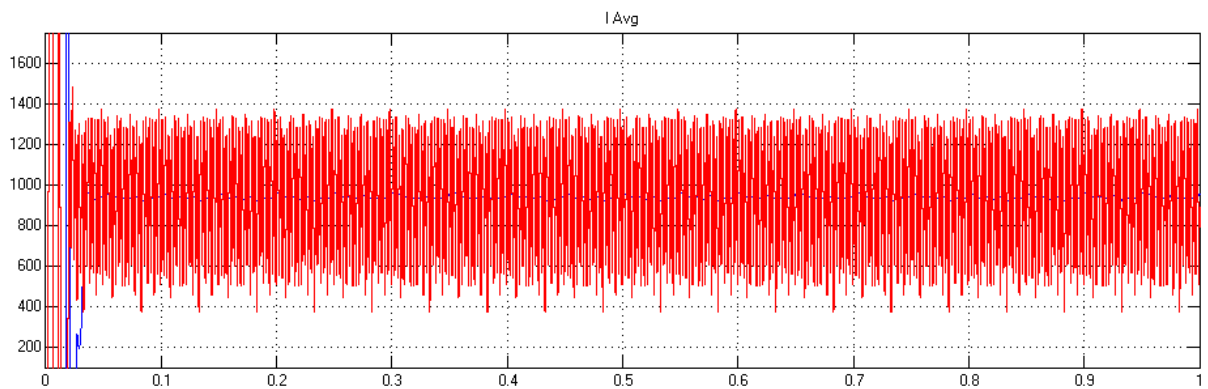

Figure 12 Average and real DC current through the DC feed in normal operation

The current ripple through the DC feed is large, but compared to the ripple on the output of the generator rectifier it is still small. This is both because the current through the DC feed is much smaller than the current from the rectifier. It also passes through the inductive cable equivalent that smoothen the current ripple. The average current is shown as the blue line in Figure 12.

Figure 13 show the voltage measurements from the external DC bus. It can be seen that the voltage ripple between the positive and negative phase is reduced due to the inductive component and the resistance in the DC-feed cable. The voltage ripple between the phases and ground however is about the same as on the Siemens bus. The voltage ripple between the phases is now about 10V.

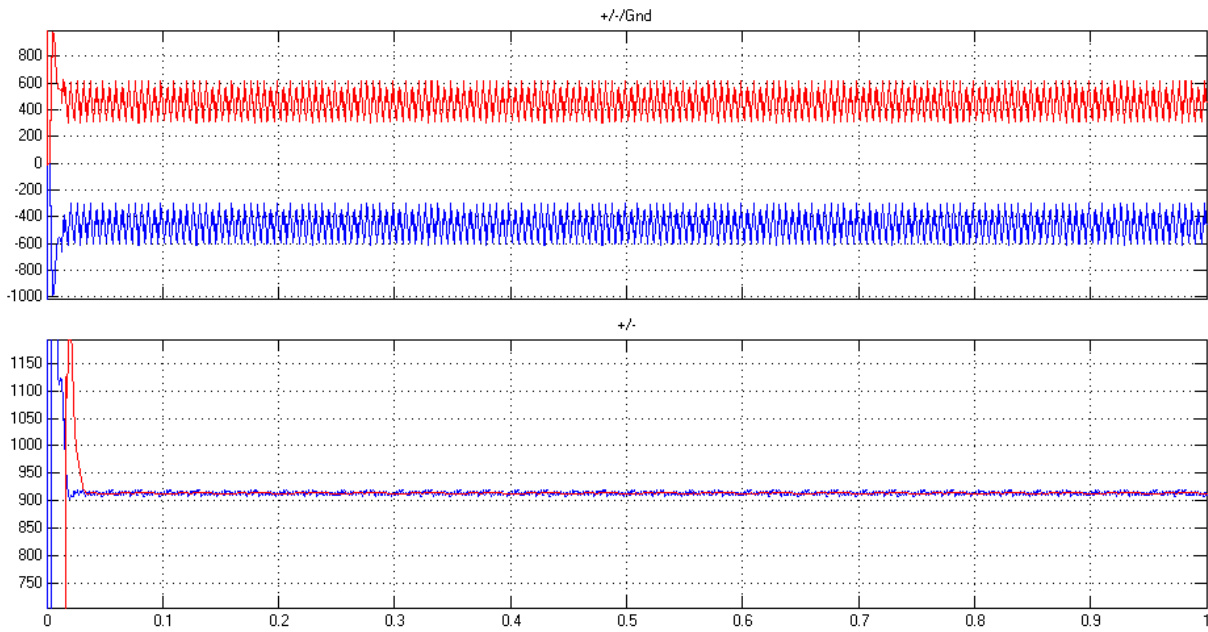

Figure 13 Voltage measurements on the external DC bus in normal operation

### 3.2.4 Thrusters

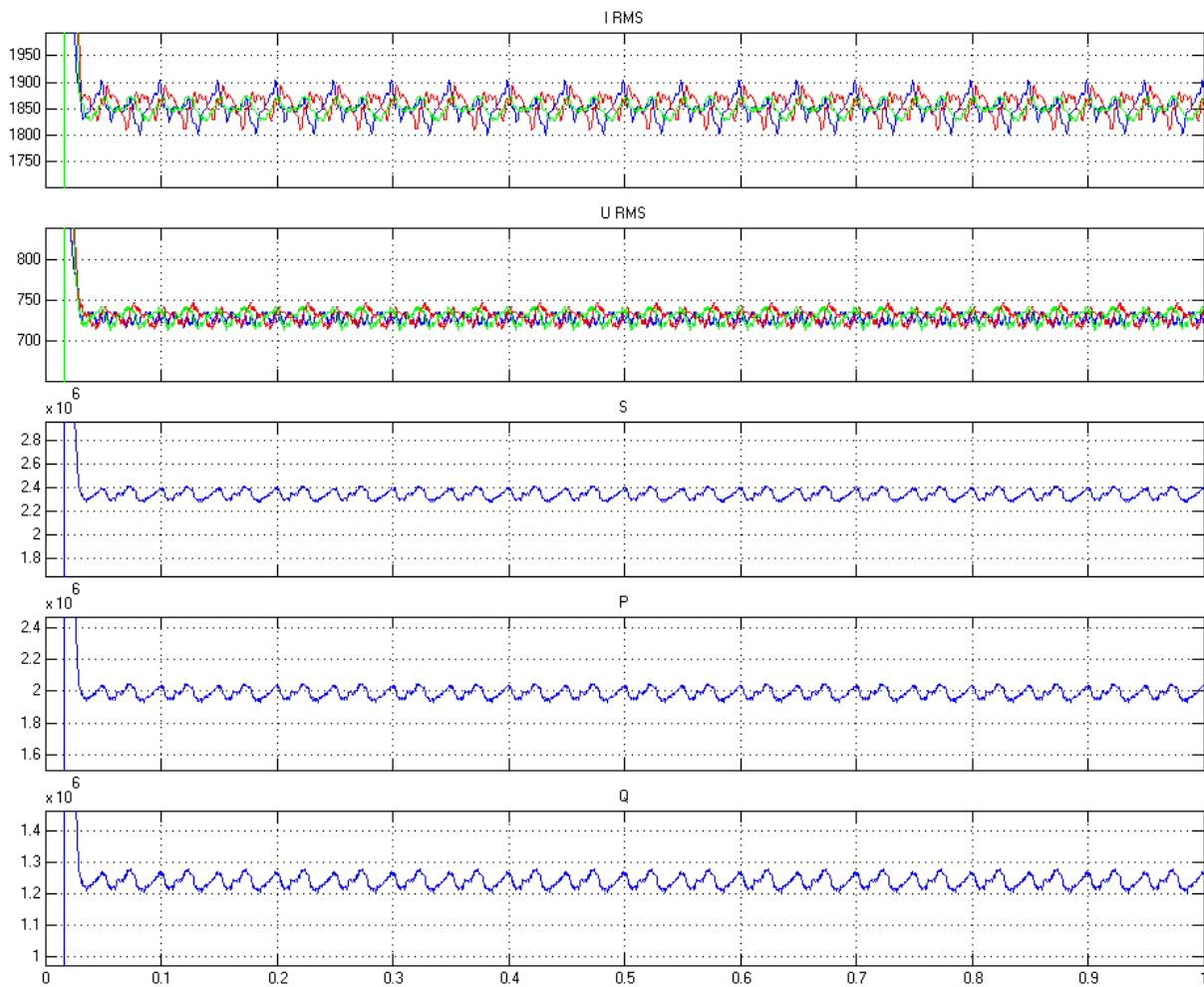

Figure 14 Current, Voltage and power results from Thrusters in normal operation

The two largest loads connected to the system are the thrusters. The thrusters are connected directly to the Siemens DC bus. The active power of the thrusters are set to be 2.05MW. Figure 14 show that the average power consumption of the load is about 2MW. The power ripple is a result of ripple in the voltage from the output of the converter. Both the apparent and reactive power consumption have about the expected values for a load with  $\cos \phi$  of 0.85.

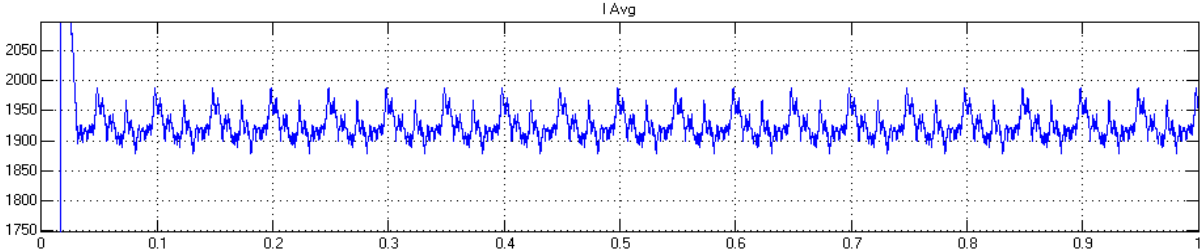

Figure 15 Average DC current through converter 1 in normal operation

Figure 15 show the average DC-current consumption of the converters connected to the thrusters. It can be seen that there are still noticeable amount of ripple even when simulating the mean current, and not the real current. The current ripple to the converter is mainly a result of the voltage ripple on the DC bus. Better converter controls or a filter placed at the input of the converter could also help reduce the current ripple to the converter.

### 3.2.5 Engine 6

Engine 6 is the smallest engine in the simulation model. This load is also the component where faults are expected to occur most frequent. It is therefore important to analyze how the different fault situations here affect the system.

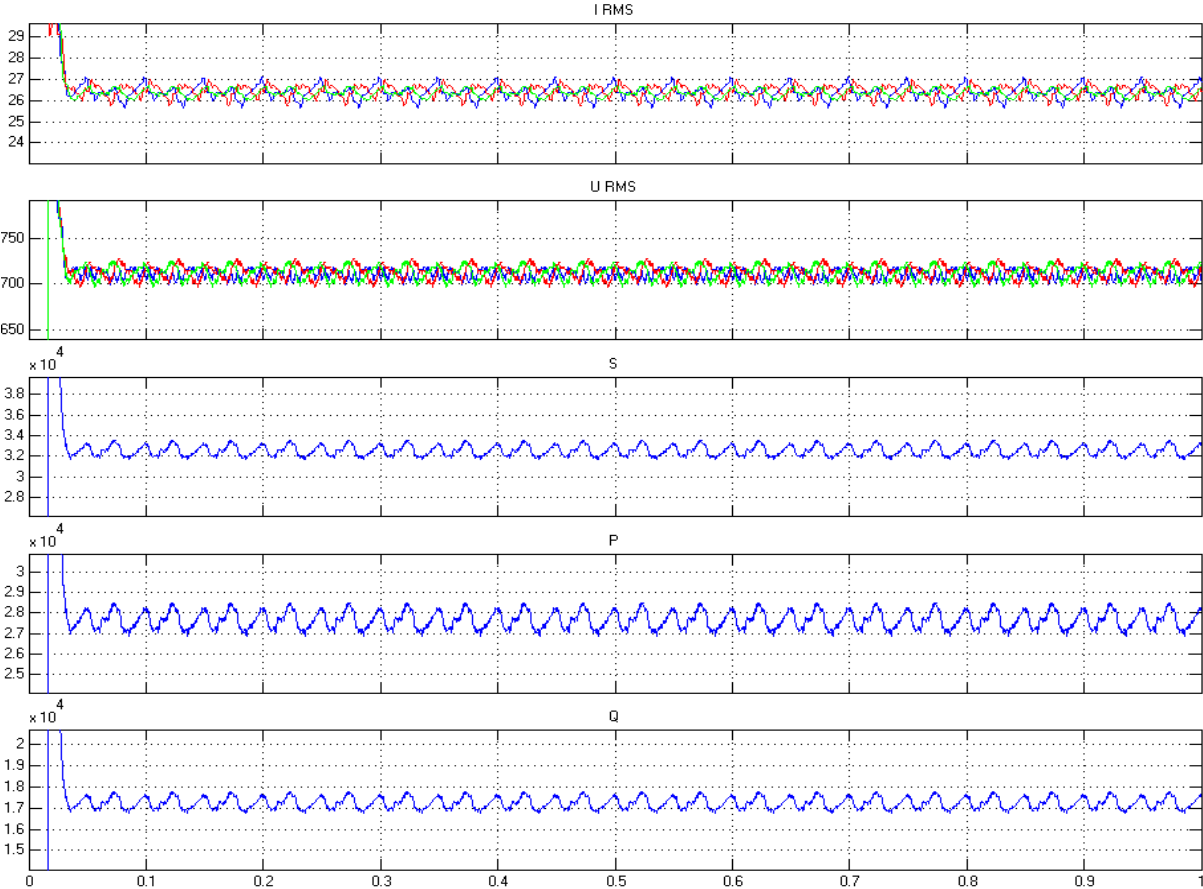

Figure 16 Current, Voltage and power results from engine 6 in normal operation

Figure 16 Show that even though the engine is set to consume 30 kW of active power, it only consumes about 27.5 kW. This is most likely to be a result of the voltage drop on the external DC bus, and will apply for all loads connected to the external DC bus. In an actual system, the converters would be able to control the output voltage, so that the converters in turn can be used to control the power consumption of the loads. In this simulation, this is of less importance, and is not considered. Figure 17 show the average DC current to converter 6.

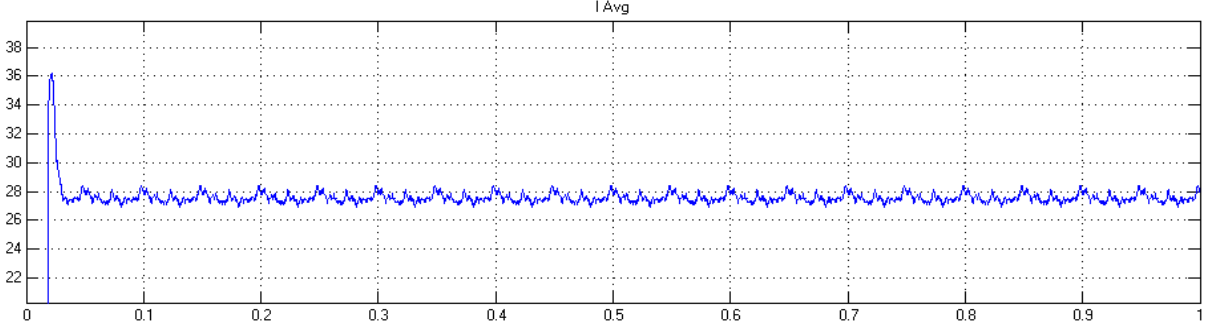

Figure 17 Average DC current through converter 6 in normal operation

### 3.2.6 Battery

Because of the ripple voltage of the Siemens DC-bus, the charging of the batteries has an equivalent charging ripple between +/-300A. In an actual system, this would not occur to this extent because the ripple on the DC bus would be much more stable. The average charging current however is about 15 A. The battery is set to be charged to 50% of its capacity in order reduce the charging current, making it easier to analyze its behavior in a fault situation. At 50% battery charge, the cell voltage of the battery is set to be 930 V (given by Siemens in appendix A). This is almost the same as the RMS voltage level of the DC bus (932 V).

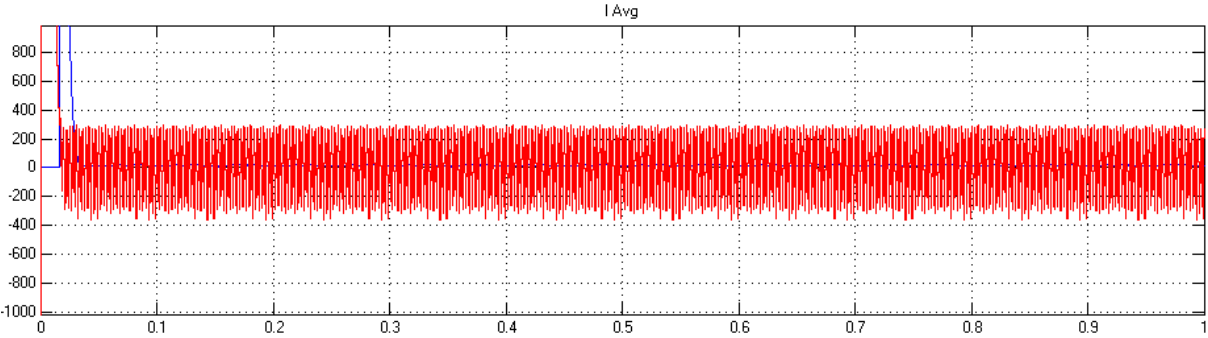

Figure 18 charging current to battery in normal operation

## 4 Fault simulations:

In the following chapter, different ground faults will be simulated at different places in the system. The system parameters are the same as described in chapter 3.2. All changes from this standard setup will be described at each fault situation.

### 4.1 One phase ground fault

In an IT power system, the first ground fault is expected to cause a very small fault current. This is because the neutral point of the generator is isolated from ground. The only fault current contribution comes from the capacitive components in the system and ground. In this simulation, the capacitive components are replaced by a large resistance between the neutral point of the generator and ground. In all the following simulations, the fault occurs after 0.2 sec with a resistance to ground of 0.001ohm unless other information is given.

#### 4.1.1 Ground fault in generator

In the following simulation, a one-phase ground fault on the generator is simulated. This is done by placing the AC fault generator at the terminals of the generator in the simulation model. The AC fault generator can be seen in red to the right in Figure 19.

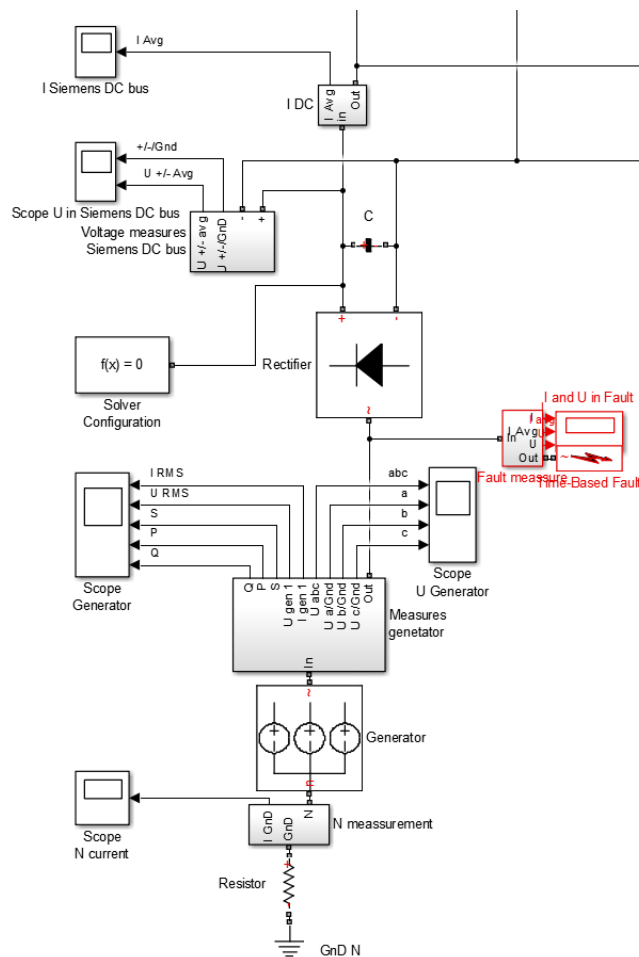

Figure 19 Placement of AC fault generator for generator fault simulation

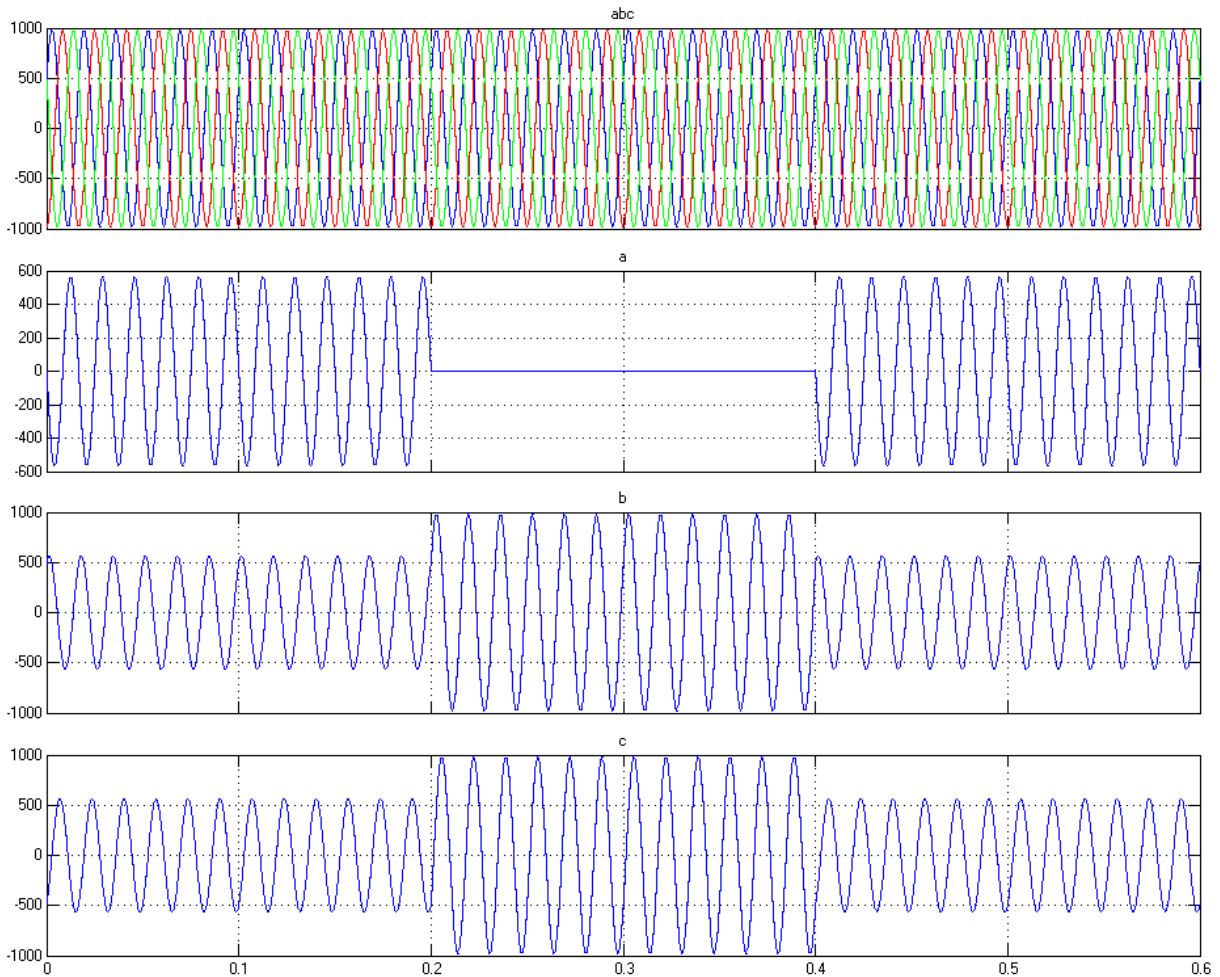

Figure 20 Voltage readings for voltage between the phases, and phases and ground.

From Figure 20 it can be seen that the fault is activated on phase a at 0.2 seconds and then disconnected again after another 0.2 seconds. After the fault is cleared, the system immediately is restored to normal operation. The fault causes the voltage between phase a and ground to become zero. This further cause the voltage between ground and phase b or c to increase. The voltage between the phases is however not affected by the fault. The voltage across the fault is the same as the voltage across the generator.

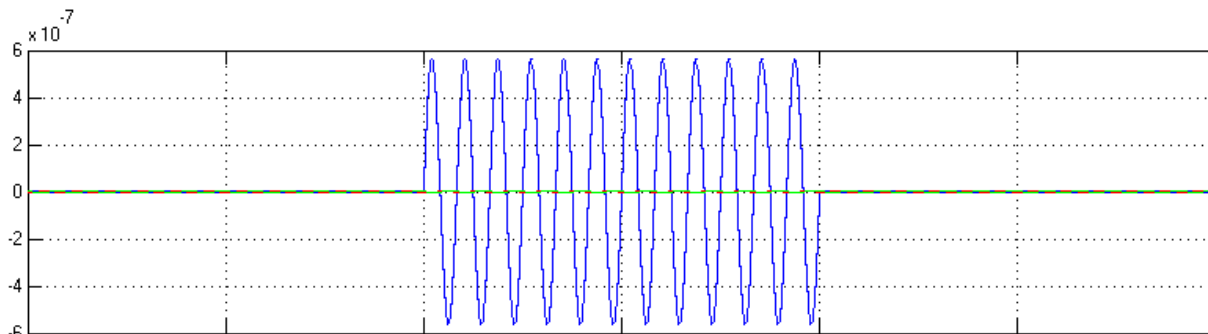

Figure 21 Fault current through the fault generator

Figure 21 show that the fault current through the fault generator is very small with a peak current of almost  $6 \times 10^{-7}$ . This fault current will not affect the system.



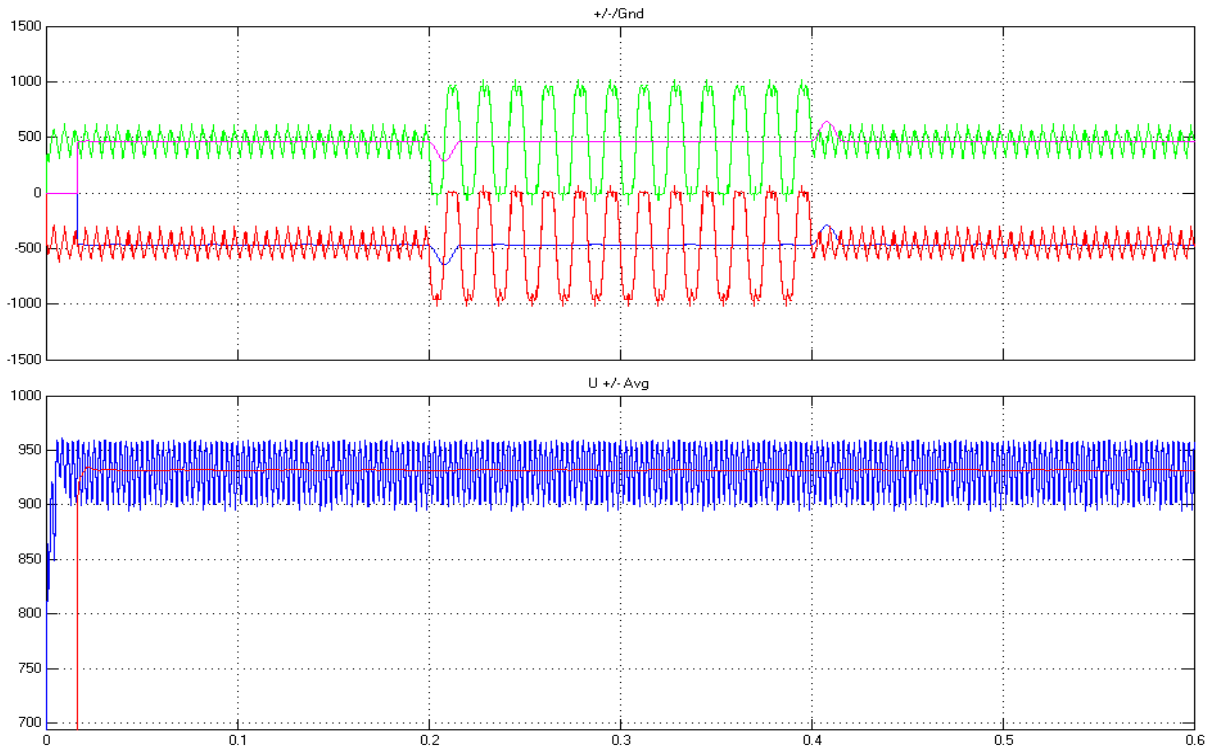

Figure 22 Voltage between +/- and ground, and between + and – phase of the Siemens DC bus

When the fault occurs at 0.2 seconds, the voltage between the two phases and ground becomes very unstable. The ripple starts pulsing between 0 and 932V. This occurs because phase a is directly connected to ground. The potential of phase a is then added to the ground potential. This gives a resulting voltage potential between the healthy phases and ground of about 932V. The voltage between the phases is completely unchanged. This can easily be seen in Figure 23 where the graphs have been zoomed in to only 0.04 seconds at the time. The fault still occur at 0.2 sec.

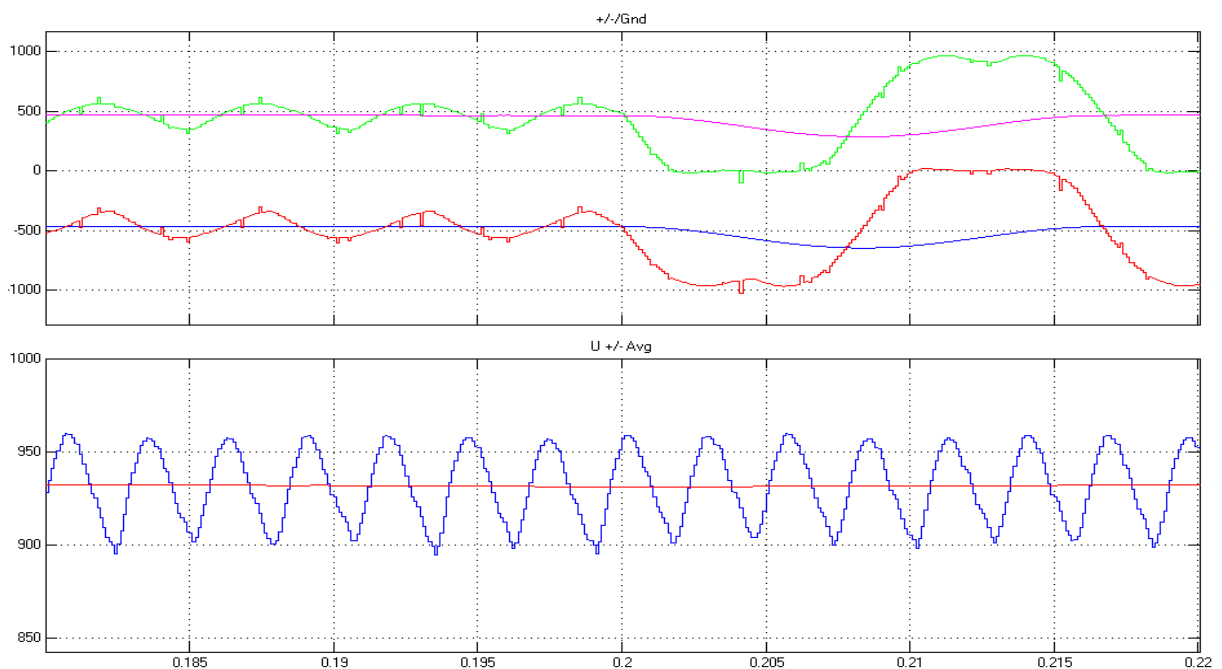

Figure 23 Zoomed version of Figure 22. Fault occurs at 0.2 sec.

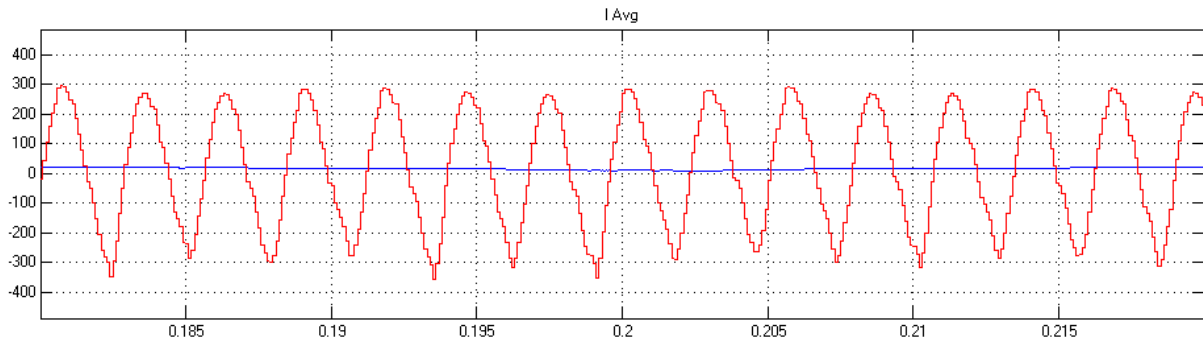

Figure 24 charging current to battery average and real. Fault occur at 0.2 sec.

As long as the battery is isolated from ground and have no reference to it, the charging current is completely un-affected by the first ground fault. This can be seen from Figure 24. Voltage across the battery is the same as the voltage between + and – at the Siemens DC bus.

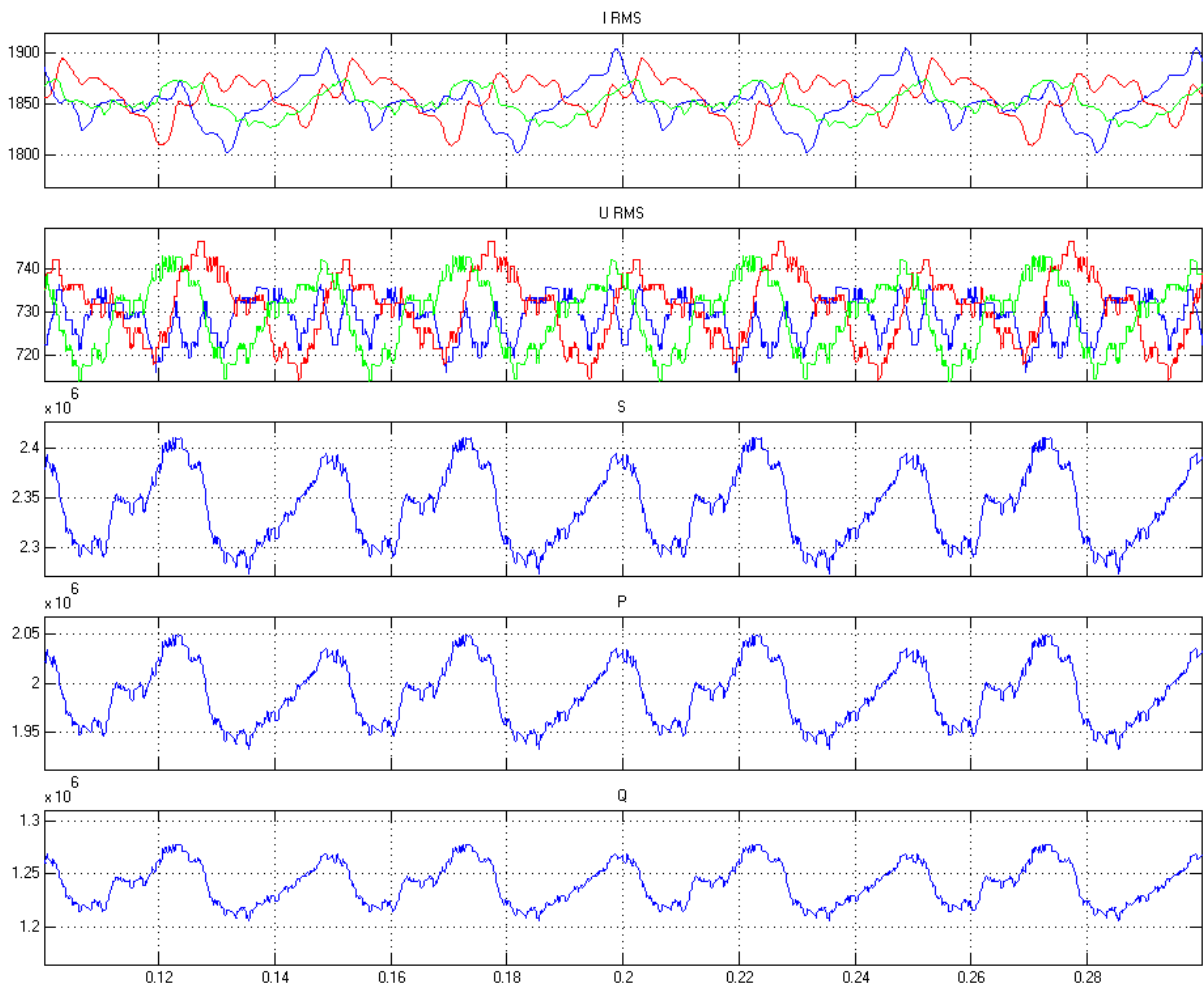
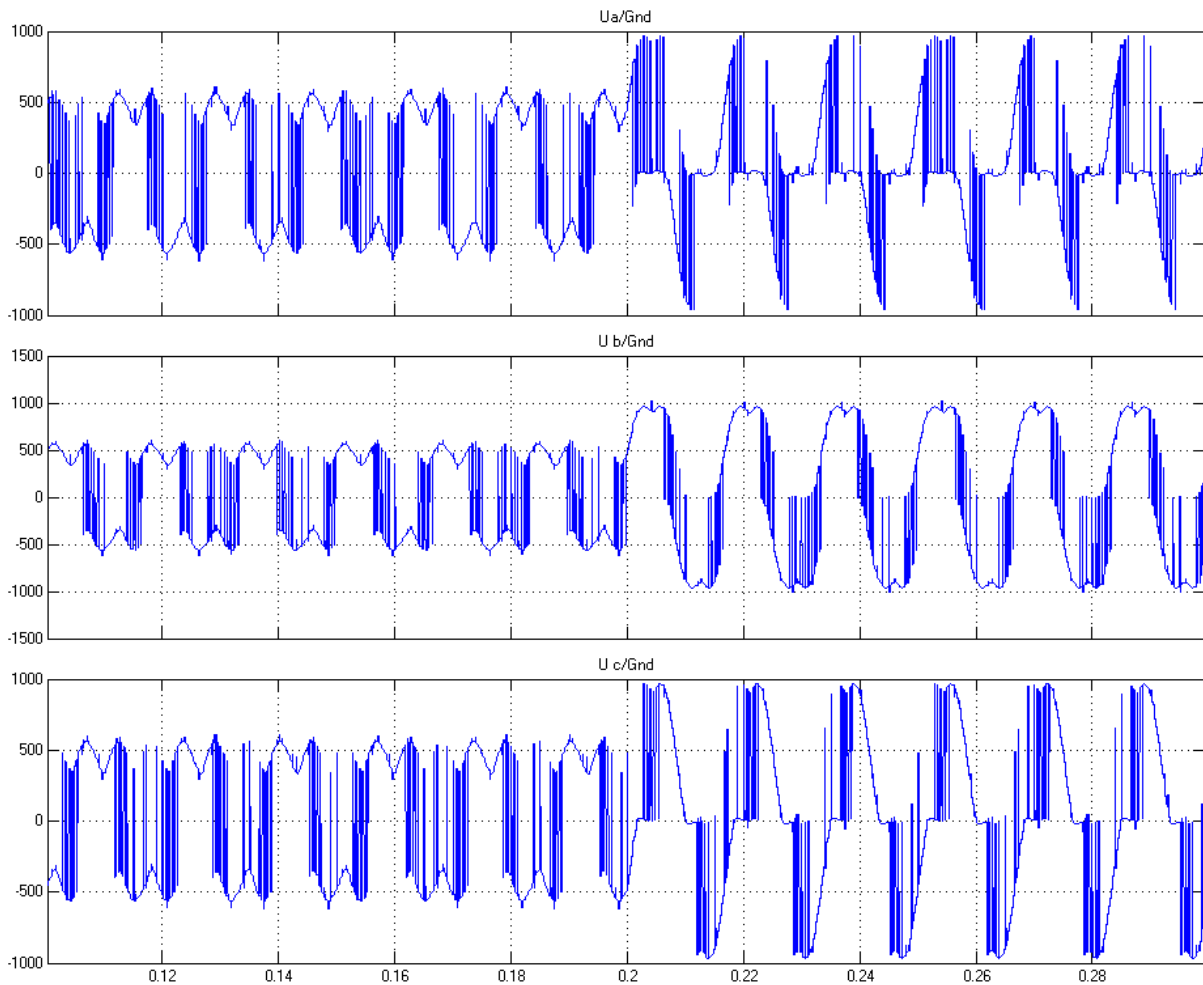

Figure 25 RMS voltage, current and power measurements on Thruster. Fault occur at 0.2 sec

Figure 25 show that the voltage and current between the phases remain unchanged at the first ground fault at the generator. This further result in no changes in the performance of the thrusters.



*Figure 26 Voltage between phase a, b and c and ground*

Figure 26 show the voltage between the three phases on the AC side of the inverter and ground. It can be seen that the voltage between phase and ground at the output is affected by the added voltage potential from the first ground fault. This causes the potential between phase and ground to have larger peaks on all phases. In addition, a zero level between the peak points can be seen.

In total, the simulation shows that the ground faults in the generator affect the system very little. The ground fault in the generator will not affect the voltage between phases at the AC or DC bus. It will however increase the voltage potential between the phases and ground. As this voltage increase, it may in rare occasions cause a hidden sub-subsequent fault. This can be a result of a weakness in the insulation. The simulation shows that the battery will not be affected when the first ground fault occur in the generator.

#### 4.1.2 Ground fault in Thruster

In this simulation, a one-phase to ground fault in the thruster is simulated. Figure 27 show where the fault is connected in the simulation model.

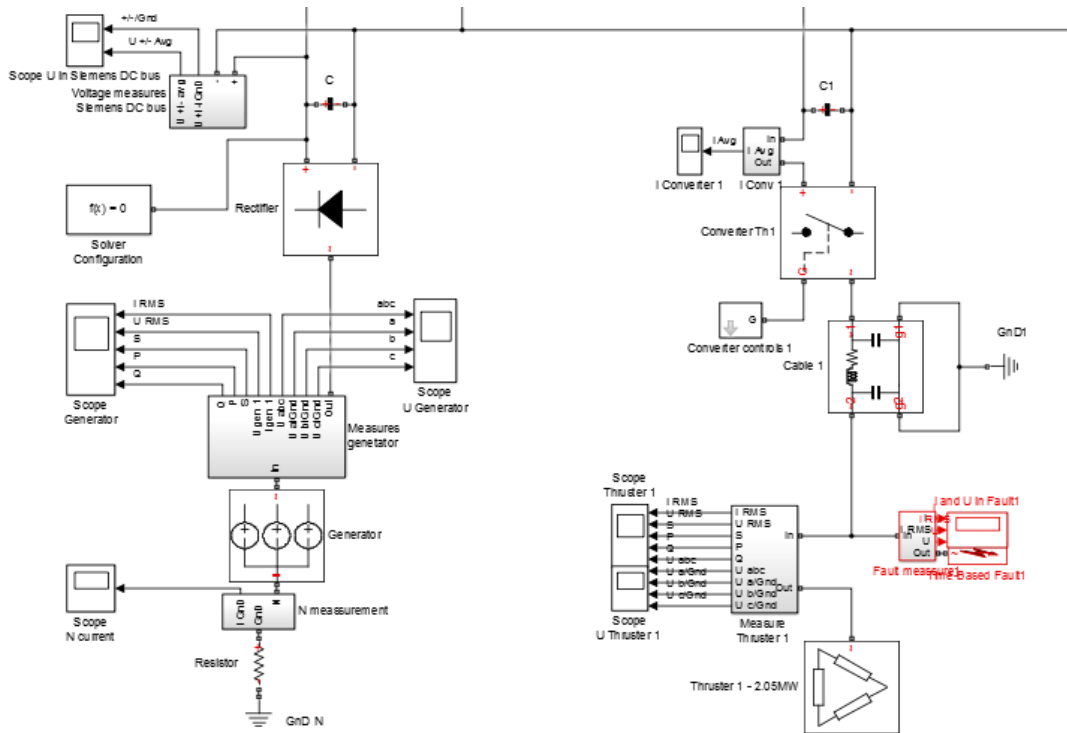

Figure 27 Illustration of placement of fault generator (red)

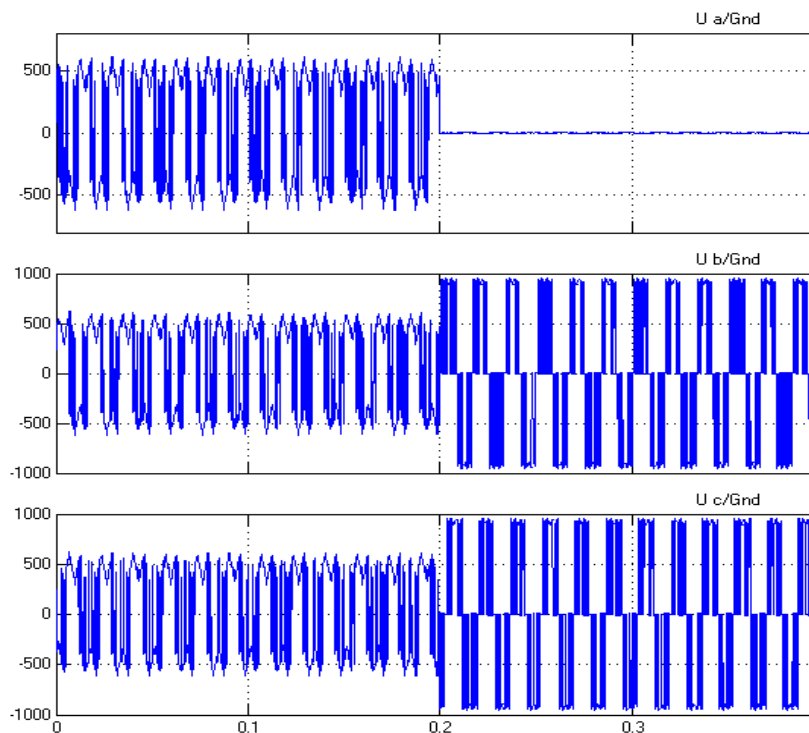

Figure 28 Voltage between phases and ground at thruster terminals with a fault at thruster 1

Figure 28 show the phase to ground voltage on the thruster terminals. It can be seen that when phase a is connected to ground, the voltage between phase b and c and ground increase to about 932V. This is caused by the change in ground potential caused by the first fault on phase a.

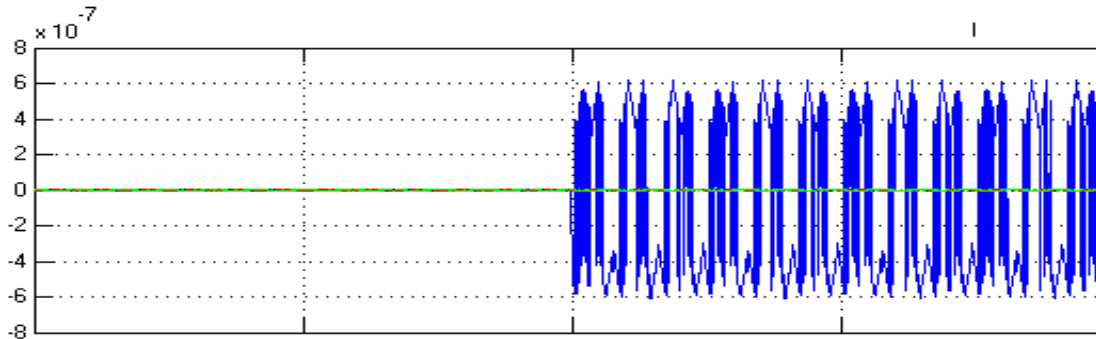

Figure 29 Fault current with a fault at thruster 1

The fault current in the first ground fault is very small, and will not affect the operation of the system.

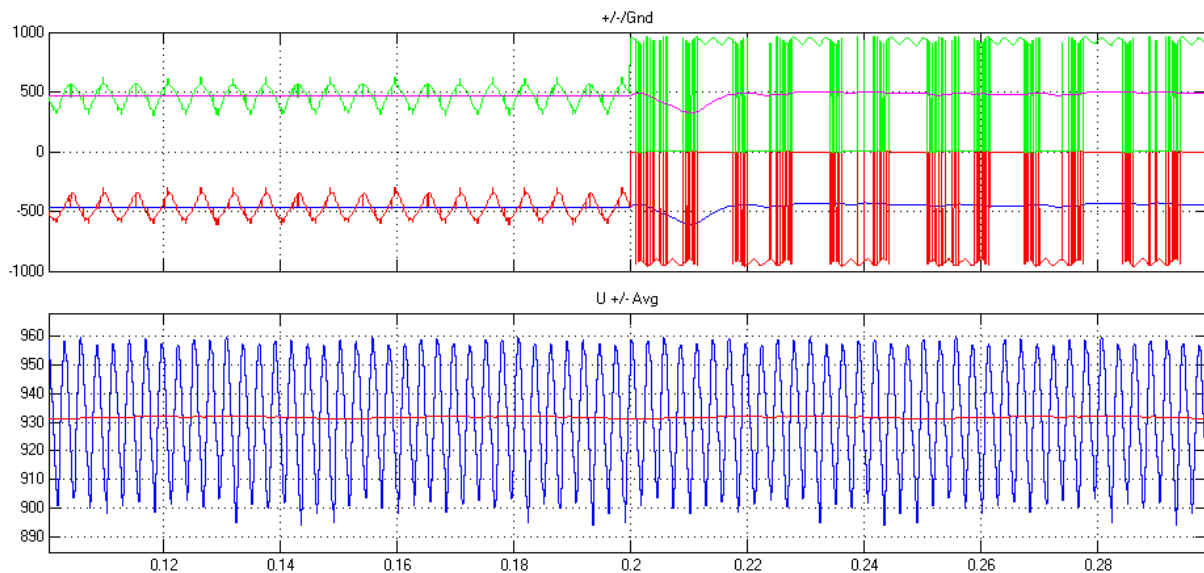
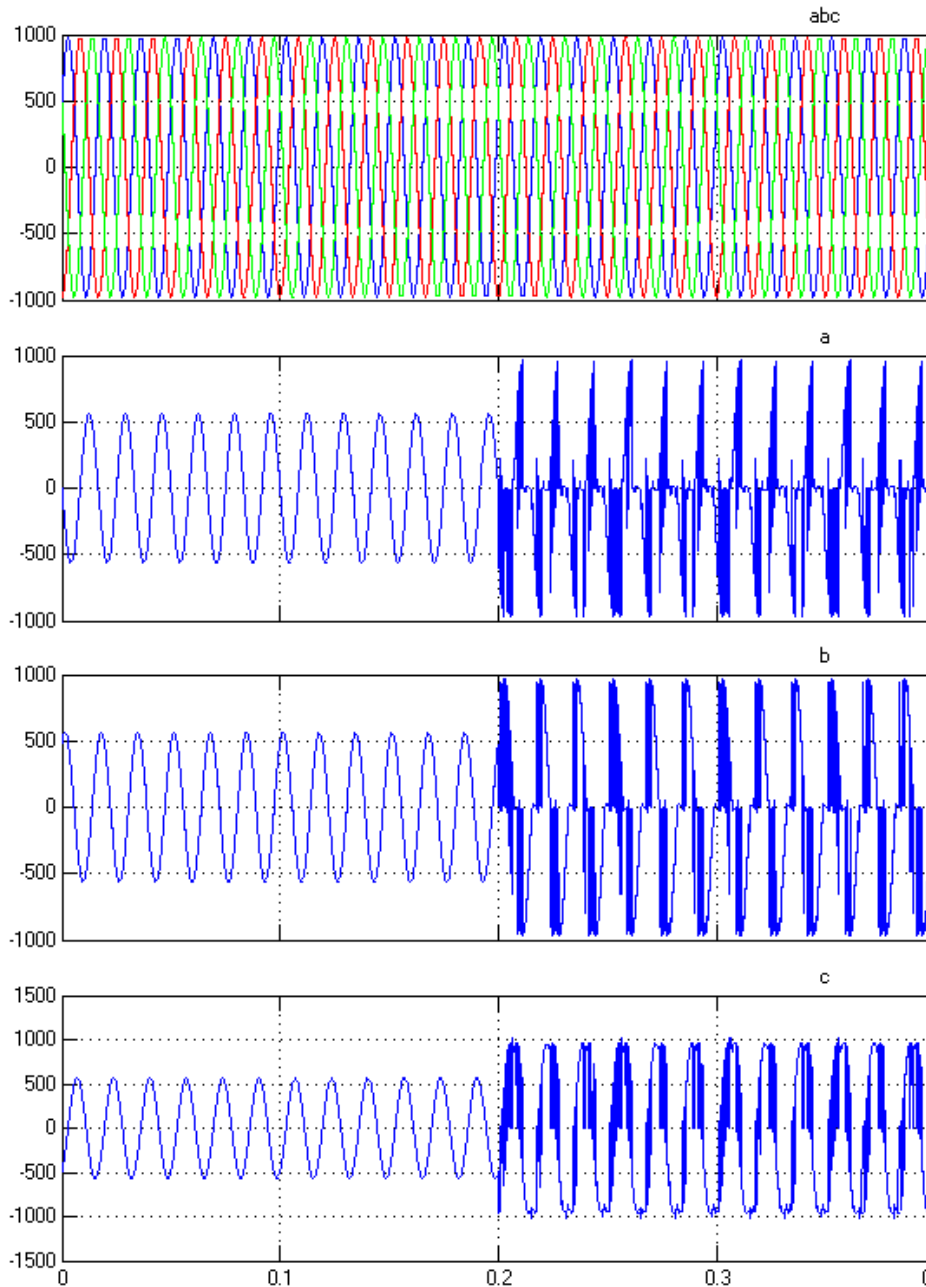

Figure 30 Voltage at the Siemens DC bus with a fault at thruster 1

The fault in the thrusters affects the DC bus in the same way as a fault in the generator, causing large voltage ripple from 0 to 932V between phases and ground. It is however possible to see that the fault has occurred on the AC side of an inverter, since the voltage to ground on the DC bus is not sinusoidal. The voltage between phase and ground after the fault occurs at 0.2 sec is clearly characterized by the pulse-width modulation of the inverter. The voltage between the positive and negative phases are unaffected by the ground fault in the thrusters.



*Figure 31 voltage measurements at generator terminals with a fault at thruster 1*

Figure 31 show the voltage measurements between all phases and ground in addition to the voltage readings between the phases. It can be seen that the voltage between the phases is unaffected. The voltage between all phases and ground get the same peak voltage as the voltage between the positive and negative phases on the DC bus. This increase in voltage between phase and ground could in worst-case result in a sub-sequent fault in a weakness in the system. The insulation should however be more than good enough to maintain the separation between phase and ground in this situation.

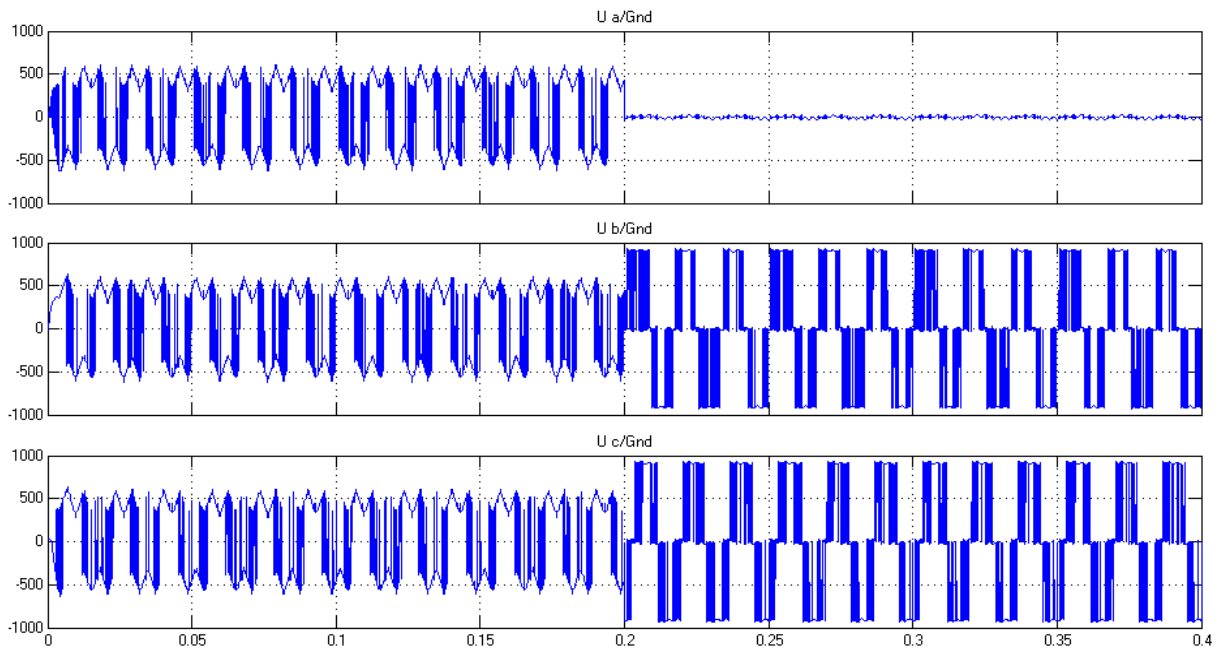

Figure 32 Voltage measurements on terminals of engine 6 with a fault at thruster 1

Figure 32 show that as long as the inverters on the thruster have the same control algorithm as the inverters on other loads, the voltage potential between phase and ground on the same phase is very similar. It can however be seen that the potential is not completely the same as in the thruster (Figure 28). A second ground fault on the same phase of this inverter would cause a medium large fault current since the load of the inverter is different from the inverter connected to the first fault. See chapter 4.2.1 for more information. Figure 33 show the same voltage readings as Figure 32, but this time the pulses per AC cycle and clock cycles per pulse are increased from 30 to 50. It can now be seen that the peak voltage potential between phase and ground is the same for all phases. A second ground fault on the same phase of this inverter would cause a large fault current. See chapter 4.2.1 for more information on this.

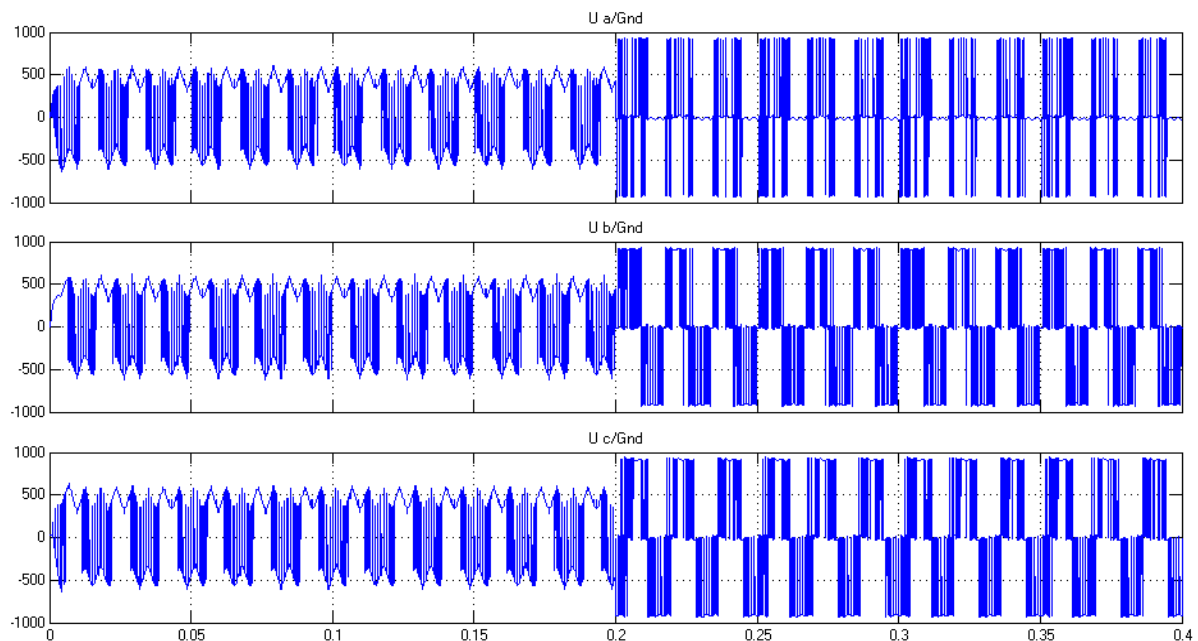

Figure 33 Voltage measurements on terminals of engine 6 with different controller algorithm

### 4.1.3 Ground fault in Engine 6

A simulation of a ground fault in engine 6 has been made in order to check if a fault on the smallest load would give a different impact on the system than if the fault occurs in a large load. The probability of a fault in the small engine is much higher than a fault in the larger engines or the main propulsion. This is because larger engines are dimensioned to handle large short-circuit fault currents, voltage spikes and other unwanted events, while smaller engines are connected to smaller drives and smaller components which is not dimensioned for large voltage spikes or currents.

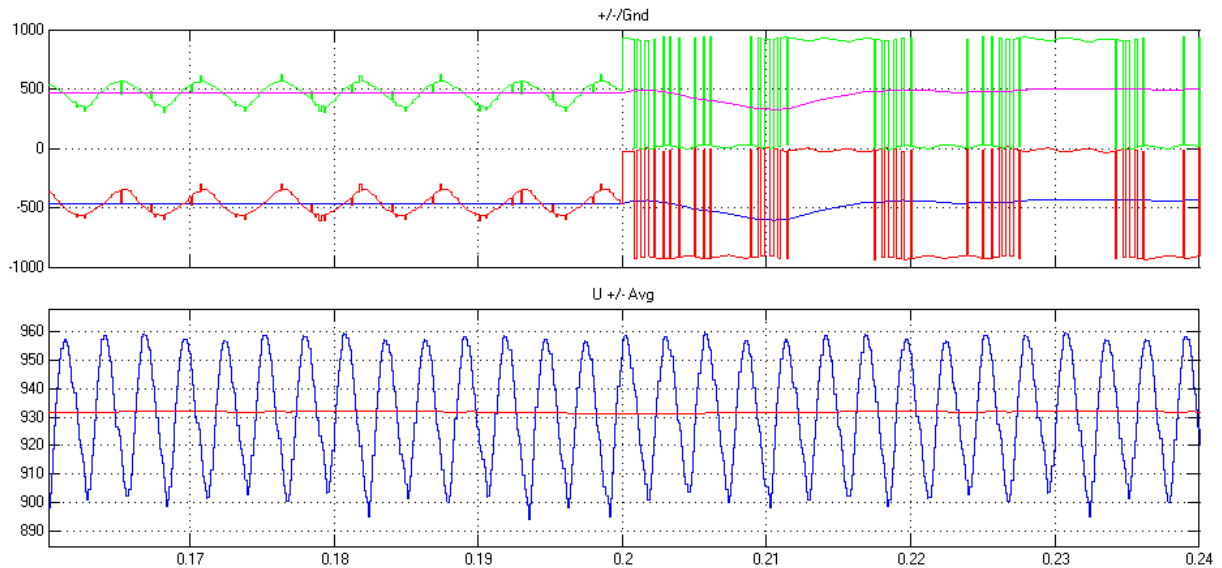

Figure 34 Voltage at Siemens DC bus with a ground fault at Engine 6

A ground fault in Engine 6 gives about the same results as a ground fault in the thrusters. The only difference caused by the fault, is that the voltage at the Siemens bus is not exactly zero at one phase as it is on the external bus. This can be seen by a comparison of the voltage around zero in Figure 34 and Figure 35. The reduced ripple between phases U +/- on the external DC bus is unaffected compared to normal operations.

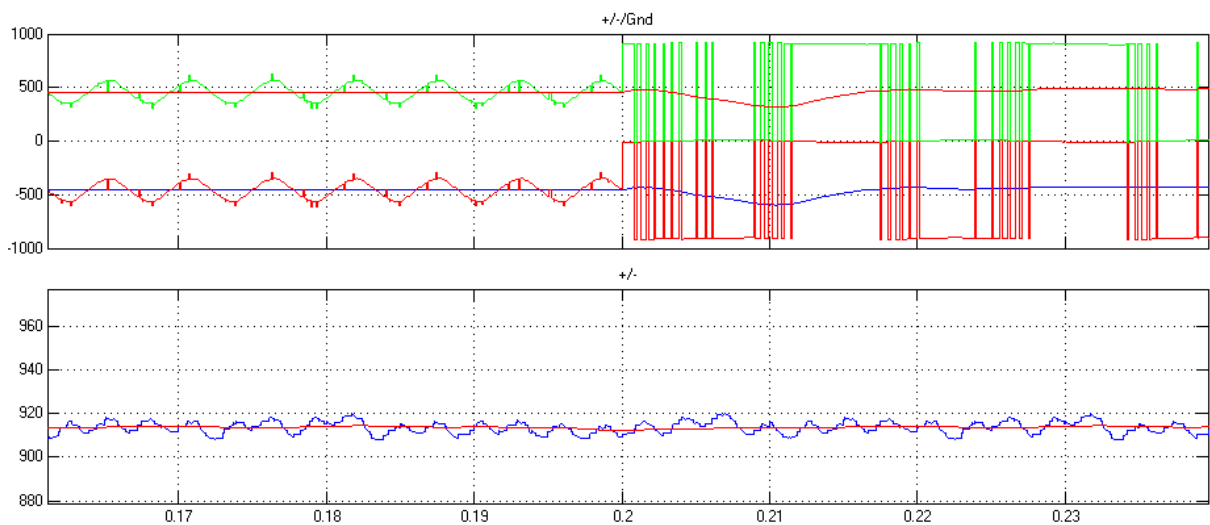

Figure 35 Voltage at external bus with a ground fault at Engine 6



#### 4.1.4 Ground fault on the external DC bus

A fault on the DC system is in general considered unlikely. If a fault however should occur, the fault is more likely to occur on the DC feed or the external DC bus compared to a fault at the Siemens bus. This is because the Siemens bus is located in one common switchboard, while the dc feeds are spread around the ship in long cables. In this chapter, a fault on the external DC bus is simulated in order to analyze how this type of fault can affect the system. A fault on the Siemens bus is not simulated, but is expected to give a similar result.

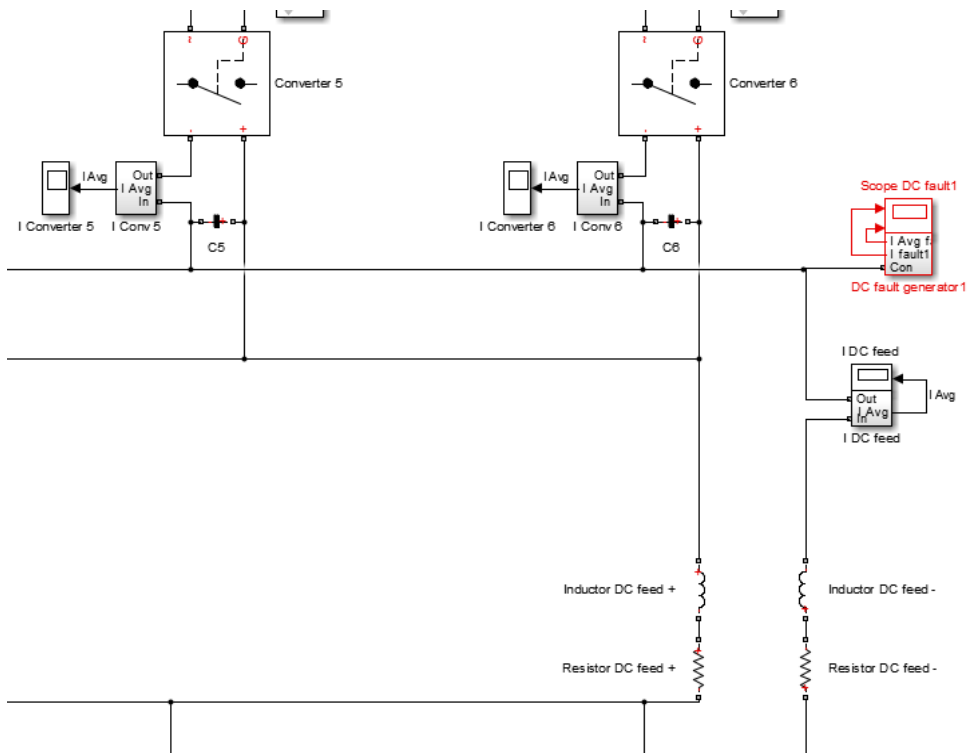

Figure 36 Illustration of placement of DC fault generation block

A DC fault-generator creates a fault between the negative phase on the DC bus and ground is activated at 0.2 sec. The resistance to ground is set to be 0.001ohm, and can be considered a direct connection between phase and ground.

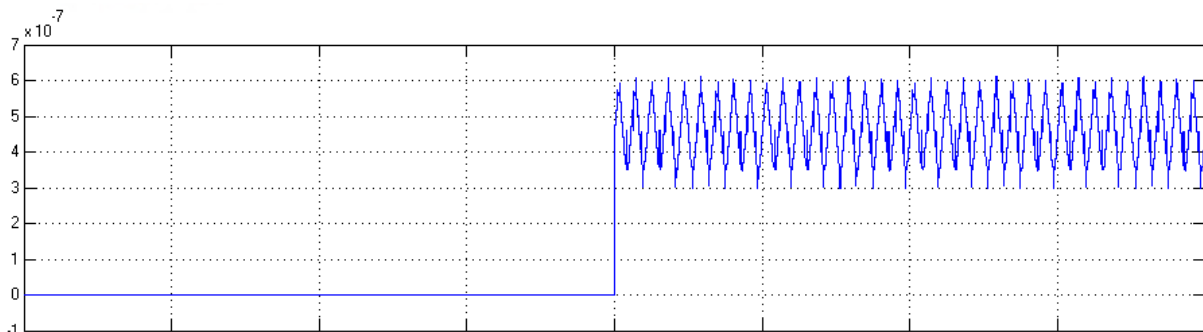

Figure 37 fault current with a fault on the external DC bus

Fault current in this case is very similar to a fault with 0.001ohm ground fault resistance. The fault is still about  $6 \times 10^{-7}$ . The difference from a fault at the AC side is that the fault current is a direct current and not an alternating current. This is expected since the fault is created in the DC part of the system.

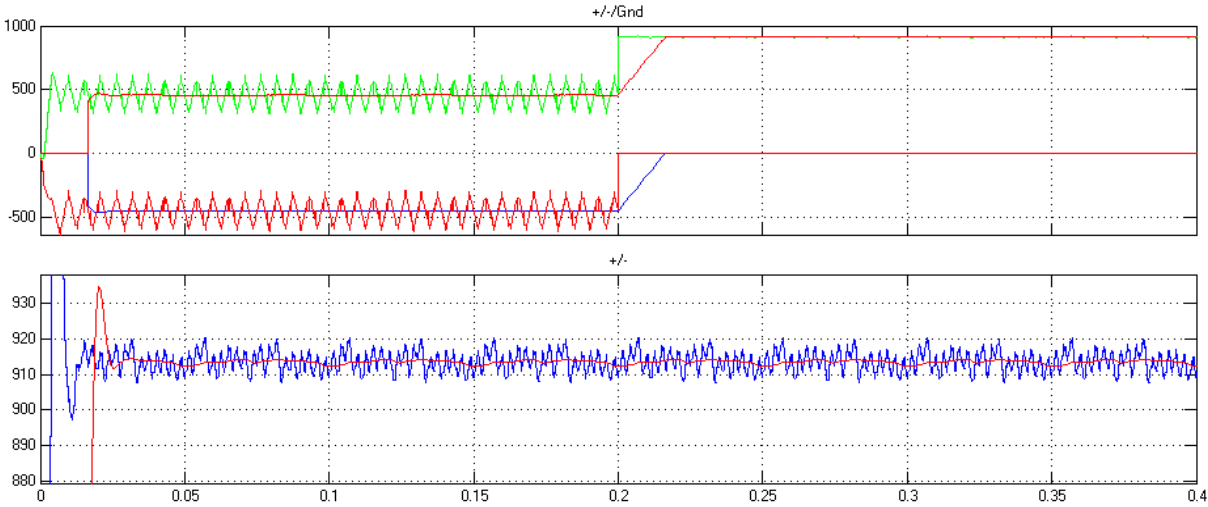

Figure 38 Voltage on external DC bus with a fault on the external DC bus

Figure 38 show voltage readings on the external DC bus when the ground fault is generated. When the fault occurs at 0.2 sec, the negative phase collapse to zero. This further pushes the positive phase to the same level as the phase voltage. Some ripple can be seen on the Siemens bus in Figure 39. The ripple is a result of the resistance and inductance of the DC feed cable. The resulting voltage between the positive and negative phase is still completely unchanged. As a result, this ground fault will not affect the normal operations of any components isolated from ground in the system. Simulations also show that the charging and discharging of the capacitors are unchanged during first ground fault.

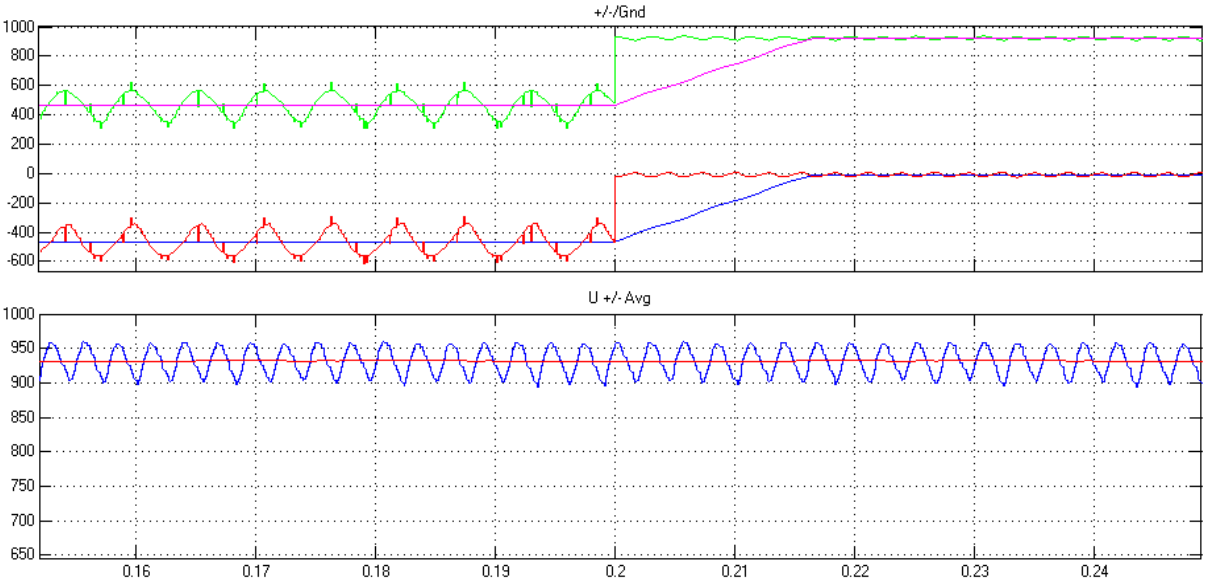

Figure 39 Voltage at Siemens DC bus with a fault on the external DC bus

Figure 40 shows the voltage at the generator terminals when the fault occurs at 0.2 sec. It can be seen that the phase to ground voltage is shifted to a peak level of about the same as the DC bus. The ripple on the DC bus also chops the top of the sine curves. The phase voltage is unchanged by the fault on the DC bus.

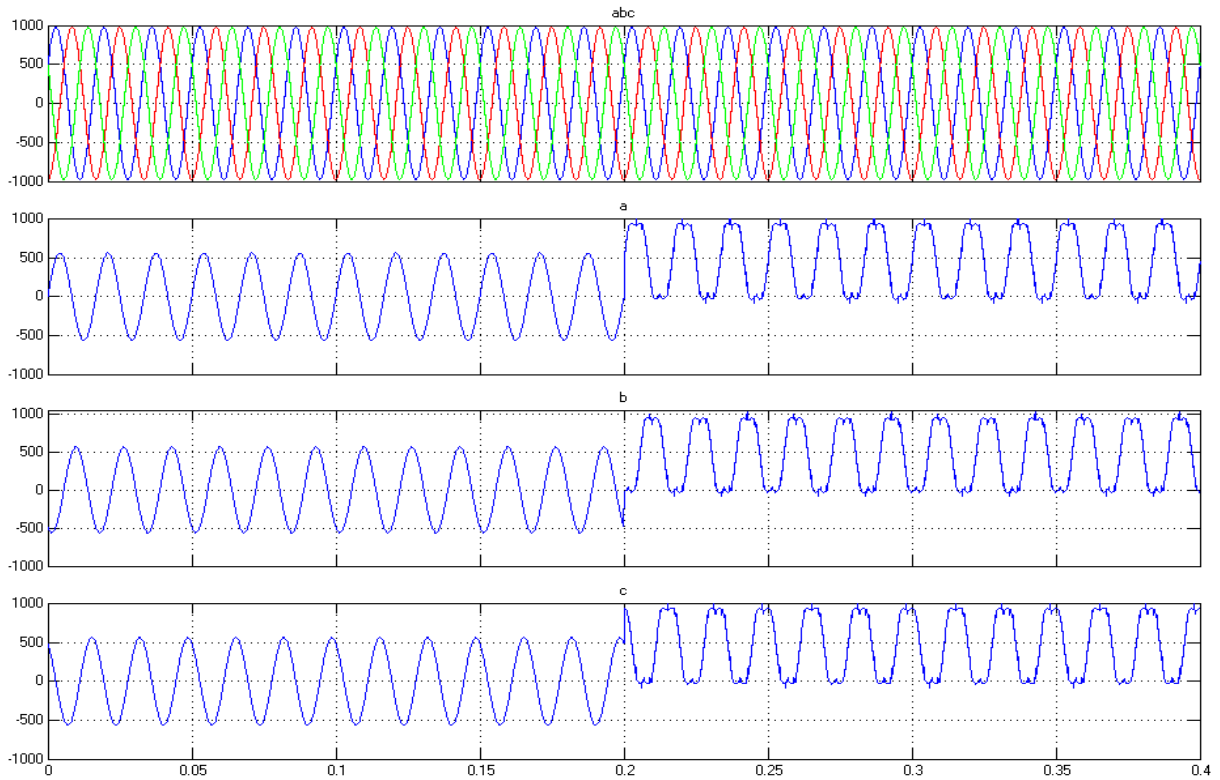

Figure 40 Voltage measurements at generator terminals with a fault on the external DC bus

Figure 41 shows that the voltages at the thruster terminals also shift in the same way as the voltage at the generator terminals. The main difference is the phase width modulation curves generated by the inverter. The voltage between phases is unchanged at the thruster terminals.

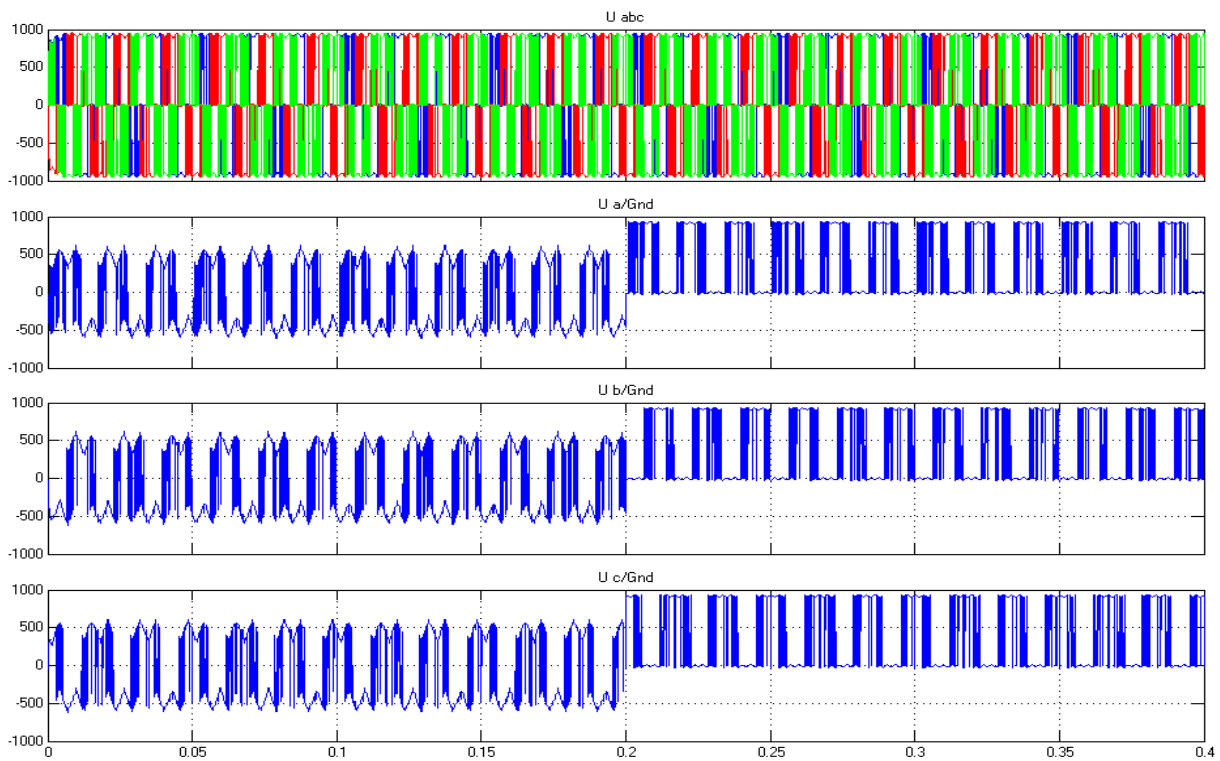

Figure 41 Voltage measurements at thruster terminals with a fault on the external DC bus

#### 4.1.5 Ground fault with high impedance

In this chapter, a high impedance ground fault on phase a at engine 6 has been simulated. The purpose of this simulation is to analyze how the change in impedance in the fault affects the system. In this simulation, the fault impedance is 20kohm the fault is created at 0.2 sec.

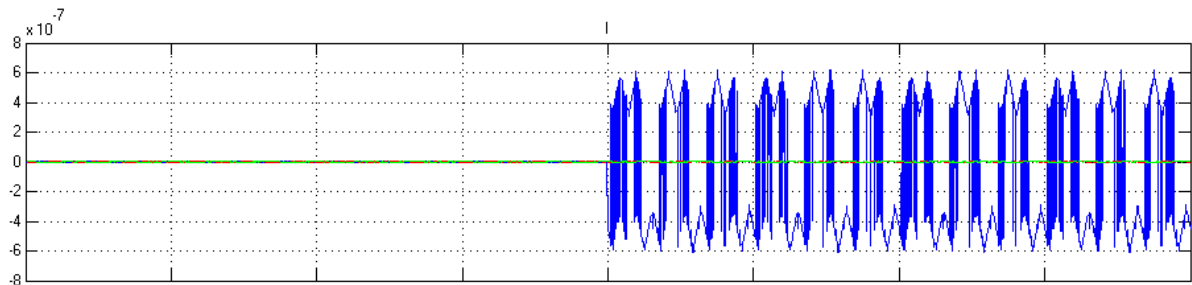

Figure 42 fault current with 20kohm fault impedance

Even though the impedance of the fault is increased, the total impedance is almost unchanged. Since the neutral point of the generator is isolated from ground with a 1000Mohm resistance, the increased resistance of 20kohm will not affect the fault current at the first ground fault.

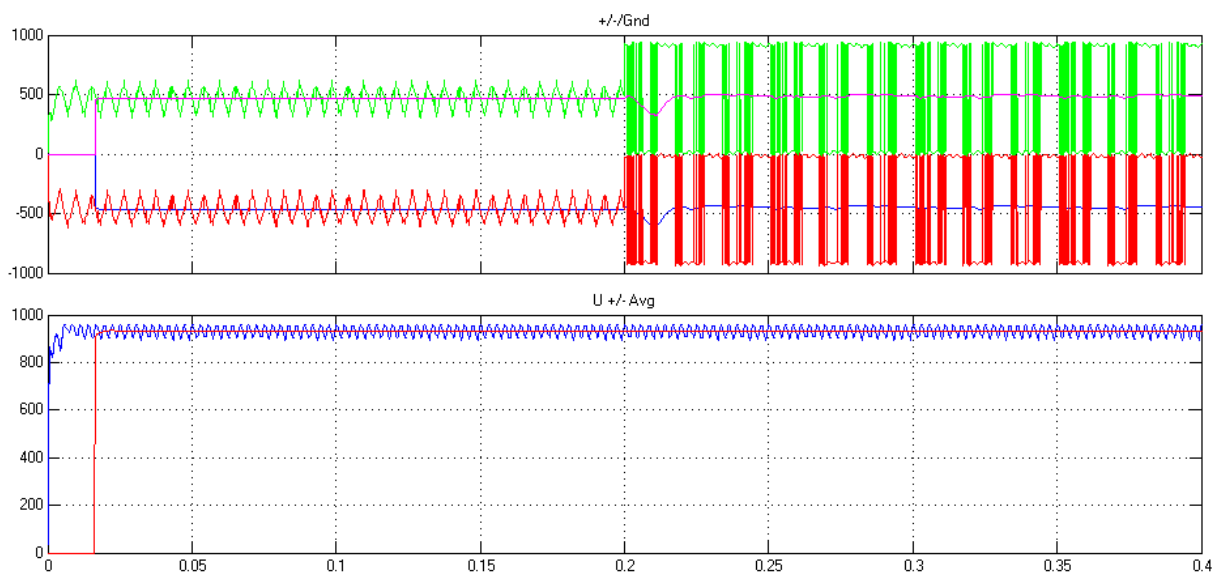
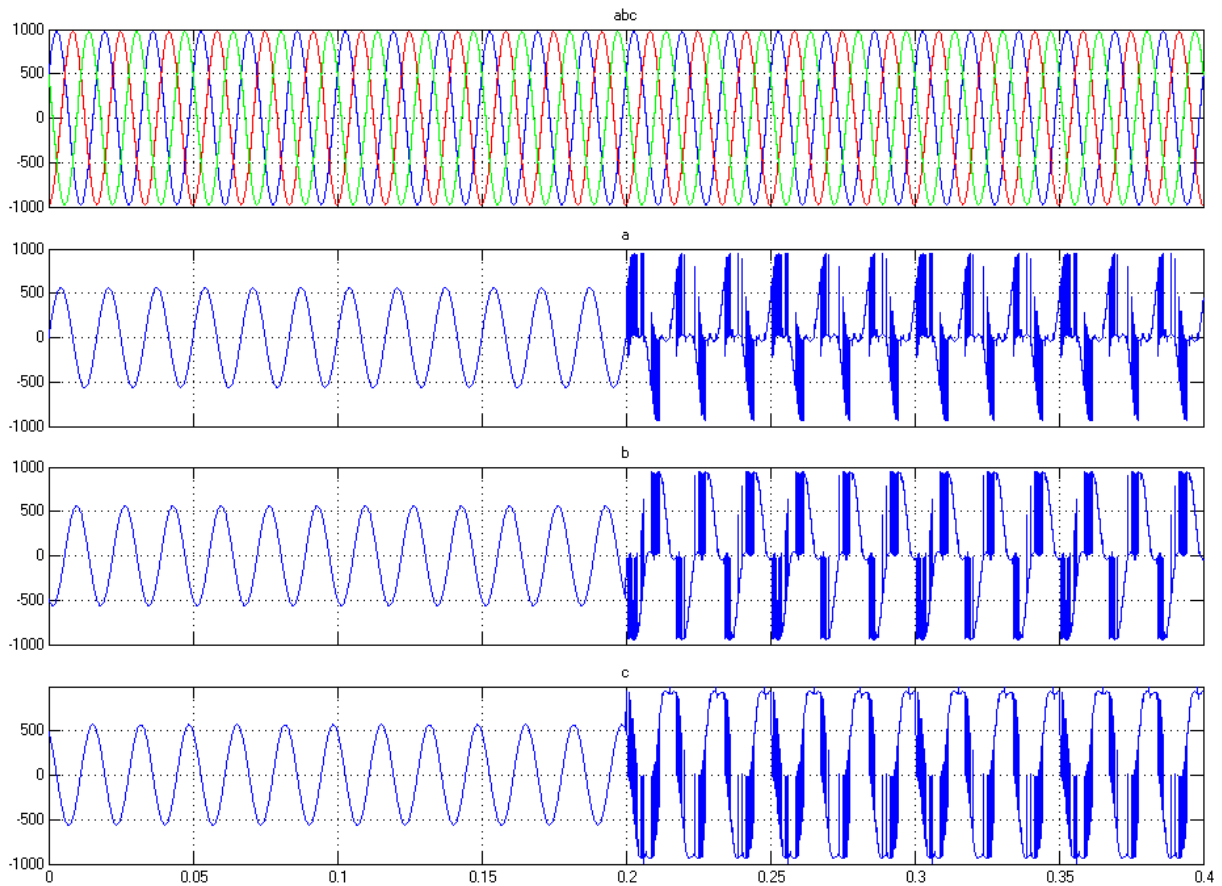

Figure 43 Voltage measurements on the Siemens DC bus with 20kohm fault impedance

The voltage readings from the Siemens bus show that the increased impedance in the fault gives almost the same results as a low impedance fault. It is however possible to see that the average voltage between the two phases and ground change compared to a fault with low impedance. This is because some of the voltage is now placed across the ground fault resistance of 20kohm.



*Figure 44 Voltage measurements on generator terminals with 20kohm fault impedance*

The voltage measurements on the generator terminals show that the high impedance fault affect the voltage on the generator in the same way as a low impedance fault. The same conclusion is made when analyzing the voltage on the thruster terminals and engine 6. The measurement graphs of these loads are not included, but are very similar to Figure 28 and Figure 32 in chapter 4.1.2.

#### 4.1.6 Ground fault with reduced resistance path to N-point of generator

In order to make fault detection easier, it can be desirable to have a larger fault current than in an IT system. In order to make the fault current larger, the neutral point of the generator could be connected to ground via a resistance. It is however important that the fault current does not become too large, so that it could be harmful to humans or increase fire hazard.

In this chapter, a fault in engine 6 has been simulated. Two simulations with respectively 1M $\Omega$  and 0.5M $\Omega$  resistance between the N-point and ground are conducted. Simulations with fault at both engine 6 and thruster have been made. The results at the two fault locations are very similar, and are therefore presented as one result.

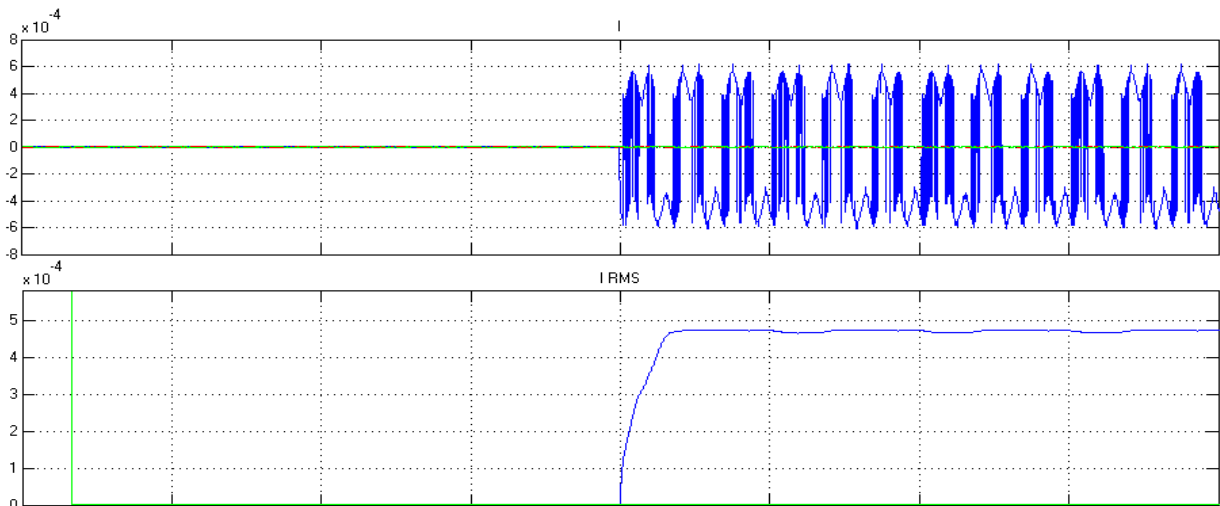

Figure 45 fault current in real and RMS with 1M $\Omega$  resistance path to neutral point

The voltage results are very similar to the results presented in chapter 4.1.2 and is therefore not presented in this chapter. The reduced resistance path only change the result from the measurement of fault current. Figure 45 show the fault current when the resistance path from ground to neutral is 1M $\Omega$ . The peak value of up to 0.6mA is far below 30mA, which is the amount of current considered dangerous for humans. The RMS fault current is a bit lower than 0.5mA. Figure 46 show the fault current when the resistance path is decreased to 0.5M $\Omega$ . The fault current now increase to a peak value of just above 1mA and a RMS value of about 0.9mA. The fault current is still well within safe fault values.

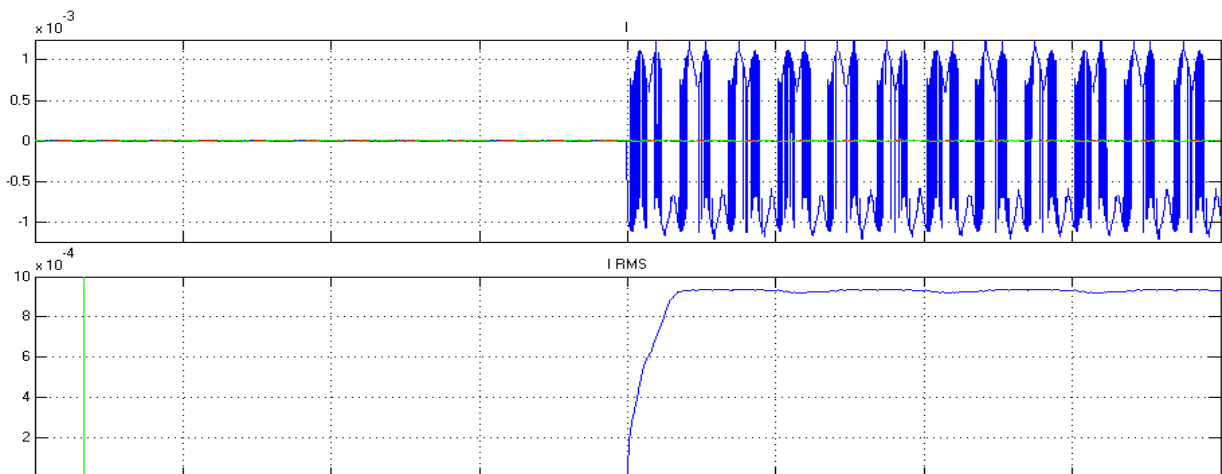

Figure 46 fault current in real and RMS with 0.5M $\Omega$  resistance path to neutral point

## 4.2 Two phase ground fault

If a ground fault occur during normal operations, it is very important to locate and clear the fault as fast as possible. The main reason for this is that if a second fault occurs, this fault may cause large fault currents that in turn can damage components in the system. In this chapter, second fault situations will be simulated and analyzed. Since the system is not dynamic, the voltage source will feed 690V no matter how big the load is. The simulations in this chapter is therefore considered less accurate. They will however give an indication on what happens if a second fault occur.

### 4.2.1 Ground fault on phase “a” on the AC side of separate inverters

This simulation is done in order to establish what magnitude can be expected if a second fault occur on the same phase as the first on the AC side of another inverter. The simulation is done with two scenarios in one simulation-timeline. The simulation first shows how a second ground fault on the same phase of another inverter with the exact same control algorithm behaves. Then the simulation show how fault current is affected by the change of load and different parameters in the algorithm. This simulation is important because it illustrates a challenge with the DC distribution system that is not present in an AC system. In an AC system, a fault on the same phase several places in the system will not generate large fault currents. In a DC system, any difference in the inverters control algorithm will cause the potential between phase and ground to become different from the other. This can occur if two loads are operated at different frequency, different pulses per AC cycle, different clock cycles per pulse or different load.

Table 2 shows how the fault simulations have been done. The table shows that a fault is first generated in thruster 1. This fault is present throughout the entire simulation. Then a fault is generated in thruster 2 for 0.2 sec before it is cleared. At 0.5sec, a fault in engine 3 is generated. This fault is cleared at 0.7sec, and so on. Grey fields represents that the fault is connected, while white fields represent that the fault is not connected.

| Time       | 0,0 | 0,1 | 0,2 | 0,3 | 0,4 | 0,5 | 0,6 | 0,7 | 0,8 | 0,9 | 1,0 | 1,1 | 1,2 | 1,3 | 1,4 | 1,5 |
|------------|-----|-----|-----|-----|-----|-----|-----|-----|-----|-----|-----|-----|-----|-----|-----|-----|
| Thruster 1 |     | ■   | ■   | ■   | ■   | ■   | ■   | ■   | ■   | ■   | ■   | ■   | ■   | ■   | ■   | ■   |
| Thruster 2 |     |     | ■   | ■   |     |     |     |     |     |     |     |     |     |     |     |     |
| Engine 3   |     |     |     |     |     | ■   | ■   |     |     |     |     |     |     |     |     |     |
| Engine 4   |     |     |     |     |     |     |     |     | ■   | ■   |     |     |     |     |     |     |
| Engine 5   |     |     |     |     |     |     |     |     |     |     |     | ■   | ■   |     |     |     |
| Engine 6   |     |     |     |     |     |     |     |     |     |     |     |     |     |     | ■   | ■   |

Table 2 show when different faults in different components are generated

For this simulation, the setup of the different converter controllers is of great interest in order to analyze how different changes in the algorithm affect the fault current. Table 3 show the setup and loading of the different converters in the simulation. All faults have occurred between phase a and ground with the same path resistance of 0.002ohm.

| Converter number       | 1    | 2    | 3   | 4   | 5   | 6  |
|------------------------|------|------|-----|-----|-----|----|
| Load [kW]              | 2050 | 2050 | 500 | 800 | 200 | 30 |
| Frequency [Hz]         | 60   | 60   | 60  | 50  | 60  | 60 |
| Pulses per AC cycle    | 30   | 30   | 30  | 30  | 40  | 30 |
| Clock cycles per pulse | 30   | 30   | 30  | 30  | 30  | 40 |

Table 3 Loading and setup of converter algorithm

Figure 47 show how the fault current through the ground fault at Thruster 1 change in relation to the different converters operational algorithm. It can be seen that when the second fault in phase a occur in thruster 2 at 0.2sec, the fault current is very small (not able to see in the graph). This is because the set up on the converter and load is completely the same at thruster 1 and 2. Engine 3 also have the exact same setup on the converter, but the load is only 0.5MW. This creates a fault current of up to 300A. Converter 4 on the other hand have a different frequency than the converter on thruster 1. This generates large fault currents of up to 43kA. The frequency at engine 5 is the same as on thruster 1. However, the change in pulses per AC cycle in the controller algorithm causes a fault current of up to 6.5kA. Also at 1.4sec when the clock cycle per pulse is changed compared to the inverter on thruster 1 the fault current rise to 2kA. It is important to remember that the fault is generated on the same phase for all faults. This show that faults on the same phase but on different inverters generate large fault currents.

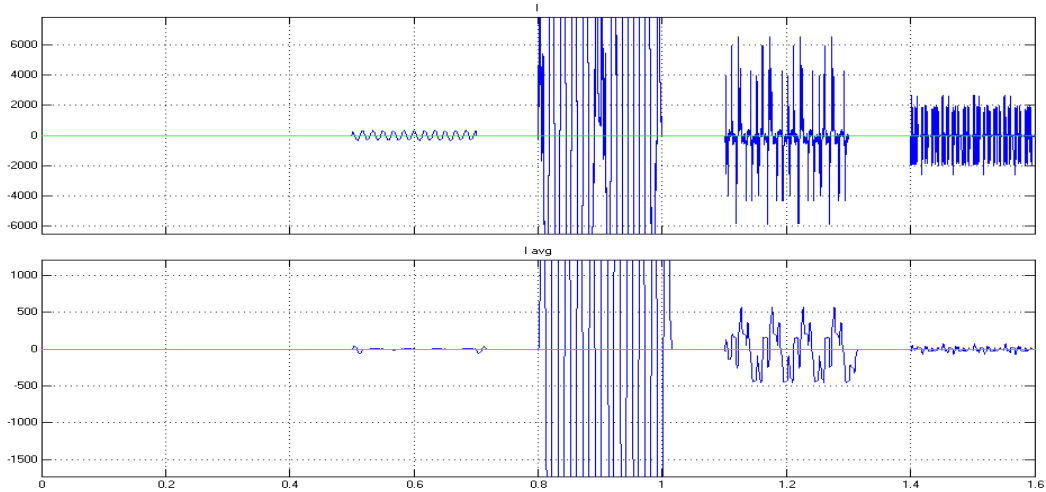

Figure 47 Fault current through ground fault on thruster 1

Figure 48 show how the different faults affect the voltage on the external DC bus. As expected, the scenario with the largest fault current also give the largest impact on the DC bus. The voltage is generally stable except when the converters have different frequency. The other fault scenarios can be seen as somewhat larger ripple on the DC voltage.

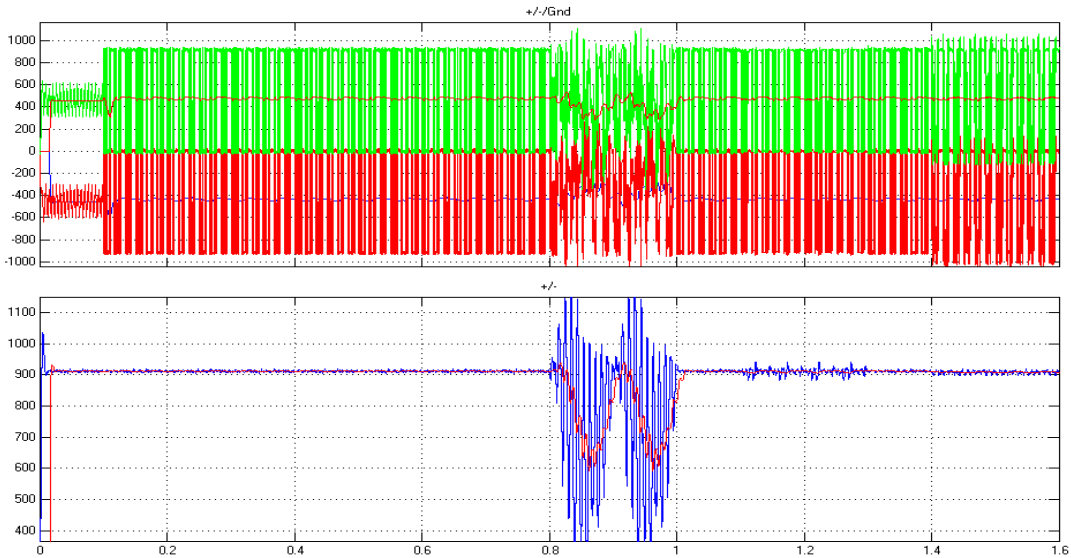

Figure 48 Voltage on the external DC bus when faults occur in phase on different inverters



#### 4.2.2 Ground fault in Thruster 1 and Generator

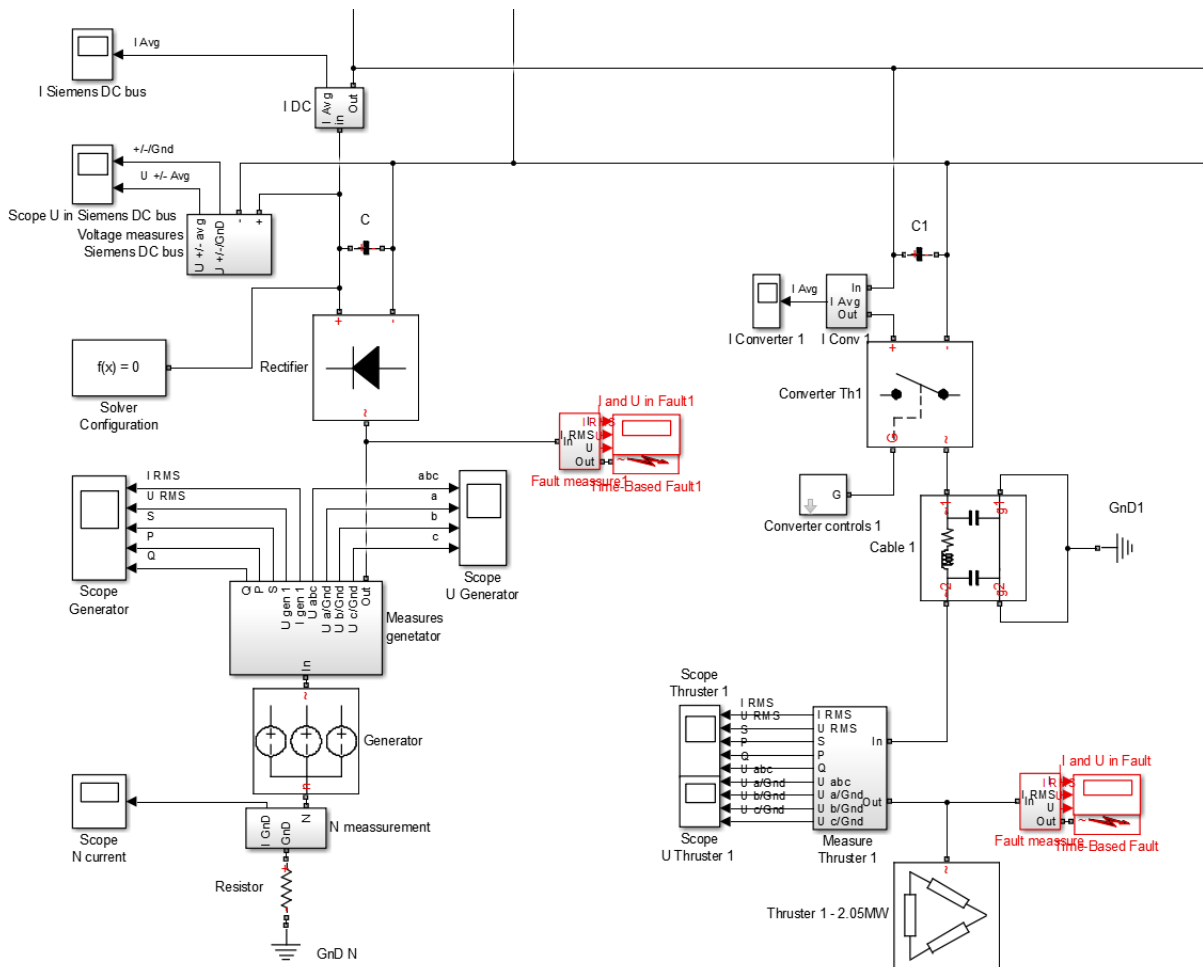

Figure 49 Illustration of placement of fault generators

Figure 49 show how the fault-generator blocks were placed in this simulation. The fault-generator at Thruster 1 connects phase a to ground at 0.1sec, while the second fault-generator at the voltage source is connected between phase b and ground at 0.2sec. Both faults have a resistance of 0.002ohm. The normal operation of the system is equal to the system in chapter 3.2.

In an actual system, the fuses and other safety equipment will help reduce the consequences of this type of fault. All inverters have fuses that help reduce the fault current in the event of a large fault current. Faults where two different ground connections occur at the same time can be considered short circuits. This simulation is not the main focus of this paper, but is carried out in order to illustrate how the second fault may affect the system. The limitations in analyzing dynamic behavior is very restricted in this chapter and will cause the results to have larger margin of error.

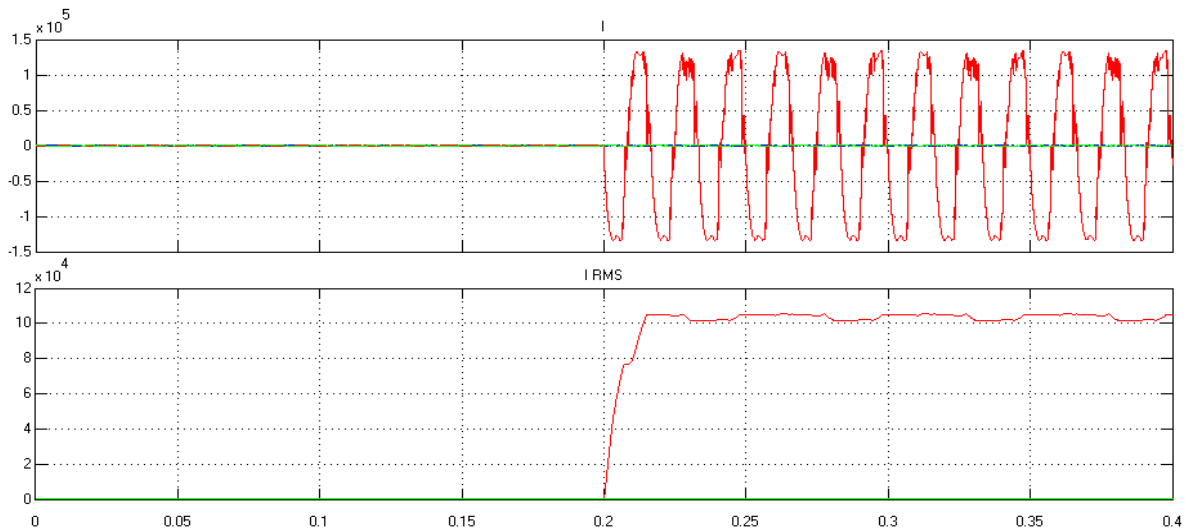

Figure 50 Fault current in real current and RMS current with faults in generator and thruster 1

Figure 50 show the fault current through the fault-generator at Thruster 1. The fault current at the first fault (0.1) is far too small to be seen in this graph, while the fault current at the second fault is very big. This is because the second fault creates a short circuit between phase b in the thruster, and phase a in the generator. The fault current is however not realistic since the generator equivalent feed the system with 690V no matter how large the load or fault current will be. In a dynamic model, the generator would not be able to supply this amount of fault current and become unstable. Figure 51 Show how the voltage between phases at the output of the voltage source remains unchanged even when the fault current becomes very large. The value in this figure is not realistic.

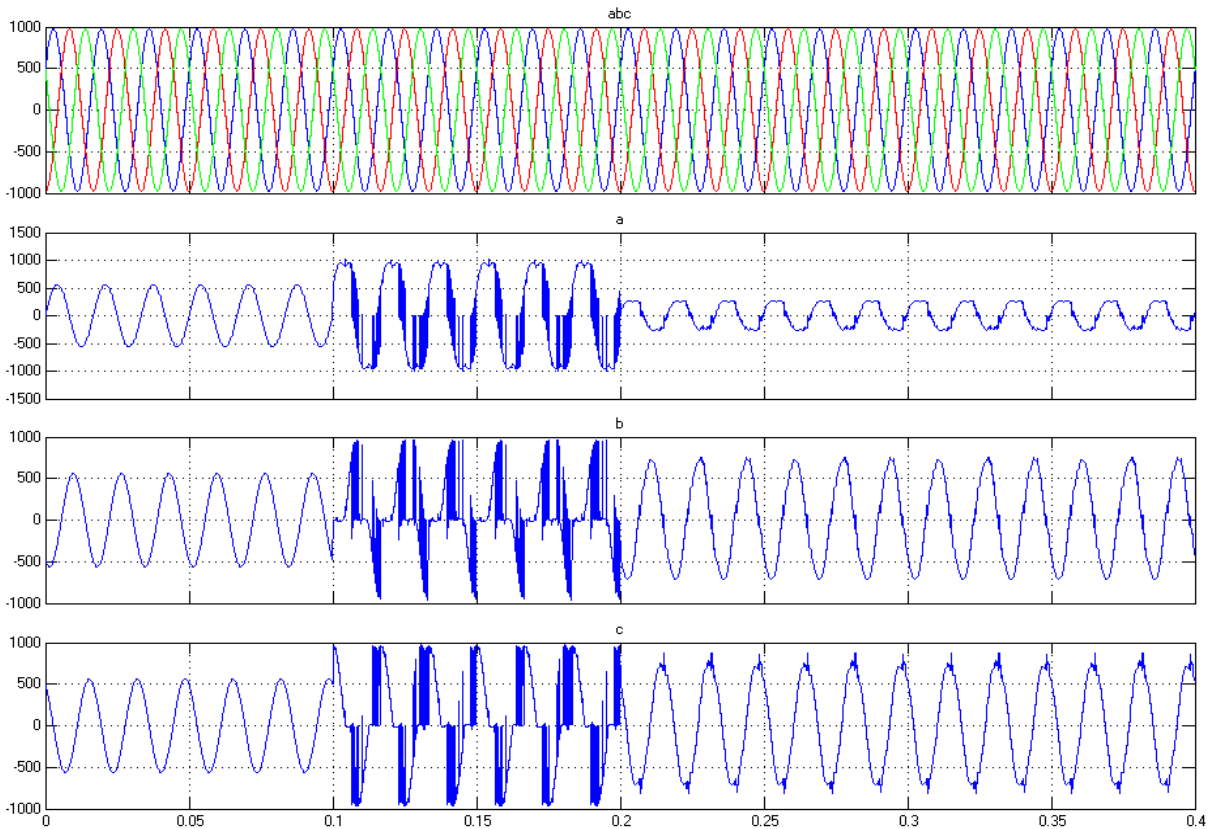

Figure 51 Voltage between phases and ground in the generator with faults in gen. and thruster 1

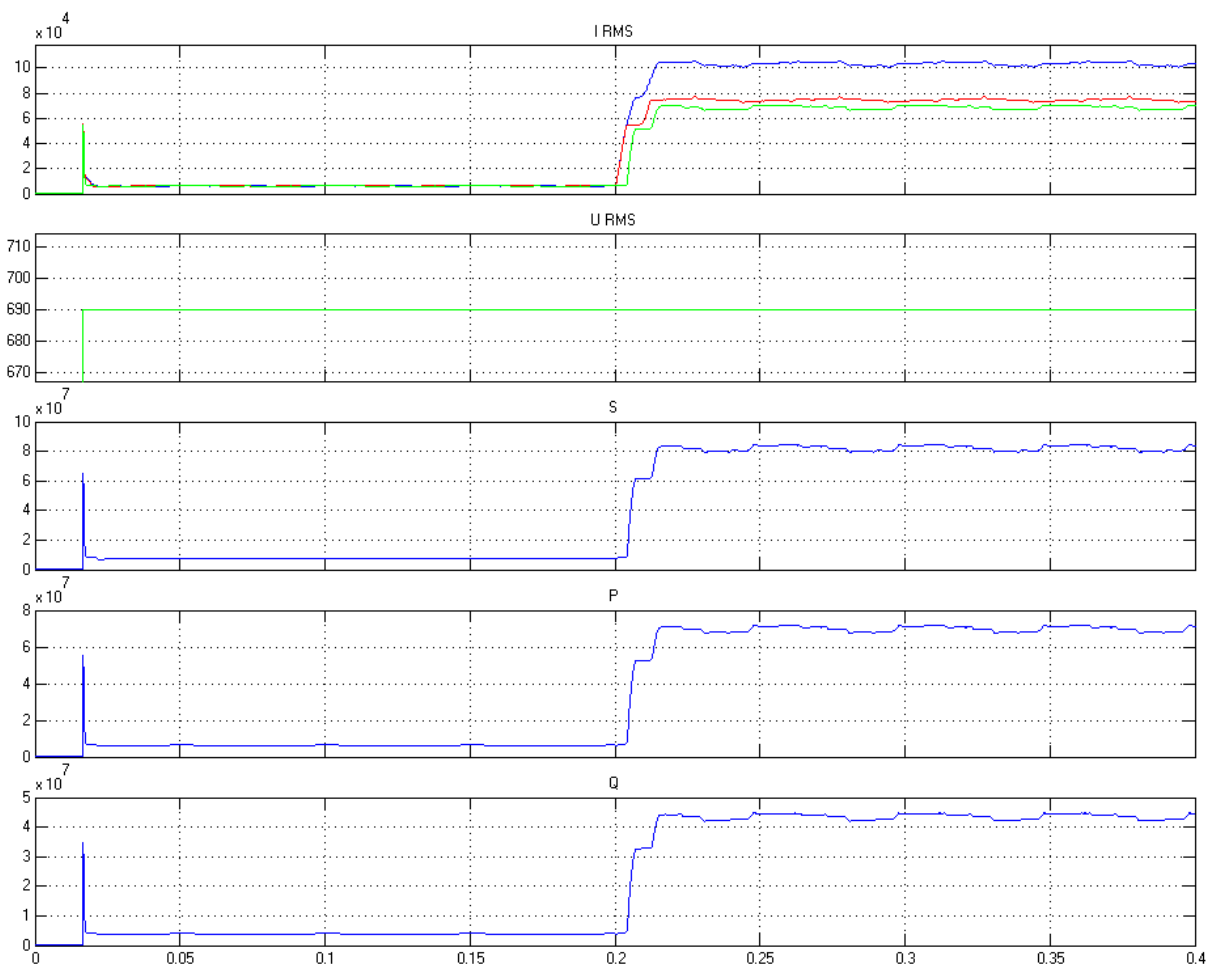

Figure 52 Current, Voltage and power on the Generator with faults in generator and thruster 1

Figure 52 show how the current, and power increase when the second fault occur. In a realistic system, the voltage would not be constant at 690V as in this simulation. The voltage would drop drastically. Figure 53 show how the current output through the rectifier increase when the second fault occur.

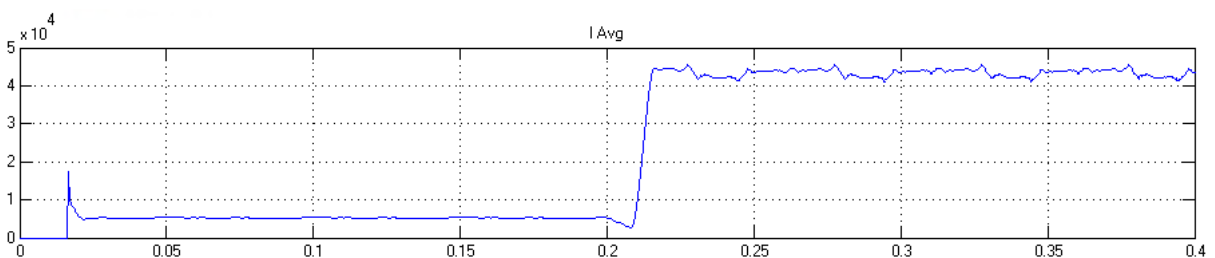

Figure 53 Output current through the rectifier with faults in generator and thruster 1

Since the DC bus is connected to a large amount of power electronic components, it is important for the entire system that the voltage here is as stable as possible. Large voltage spikes may be harmful to the power electronic equipment connected to the bus. In this simulation the voltage readings at the second fault is still not realistic, but will indicate how the fault can affect a larger part of the system than the faulty components. In this simulation, some of the fault current will travel through the rectifier and inverter and back via ground between the thruster and generator.

Figure 54 show the voltage measurements on the Siemens DC bus. It can be seen that the second fault will cause the voltage at the bus to become unstable and create voltage spikes. These spikes could be harmful to the power electronics in the system. In addition, the voltage spikes between phases and ground are very large and could harm components connected to ground. The voltage behavior at the DC bus is not realistic since the system is non-dynamic. It can however be established that the voltage on the DC bus will become unstable when a second fault occur.

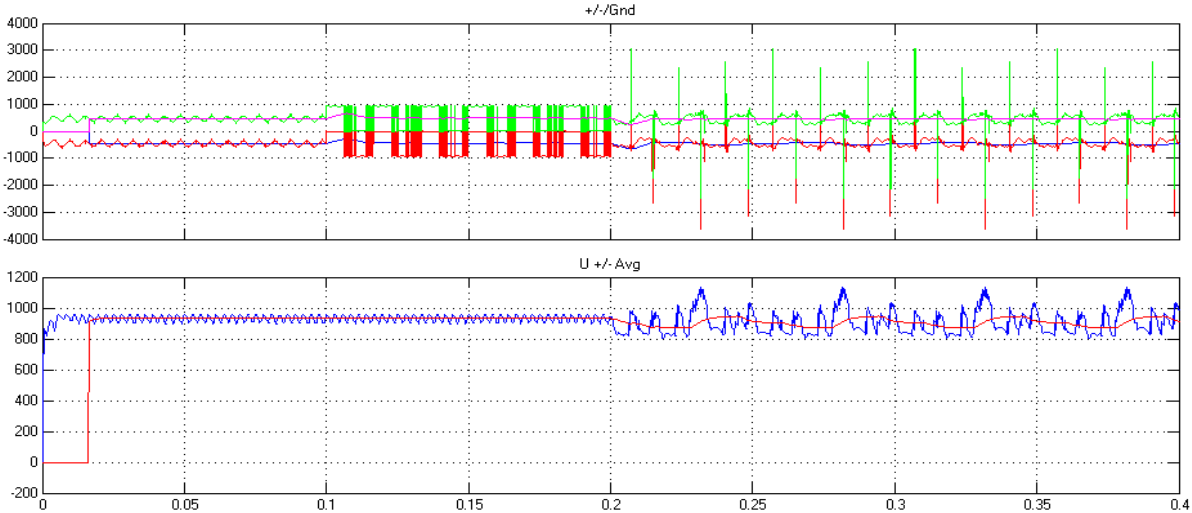

Figure 54 Voltage on Siemens DC bus with faults in generator and thruster 1

Because of the instability on the Siemens bus, the charging current to the battery becomes unstable. This simulation shows that the discharging currents from the battery may become very large. In a real system, the battery would feed a malicious current to the fault, which could be harmful for the battery over time.

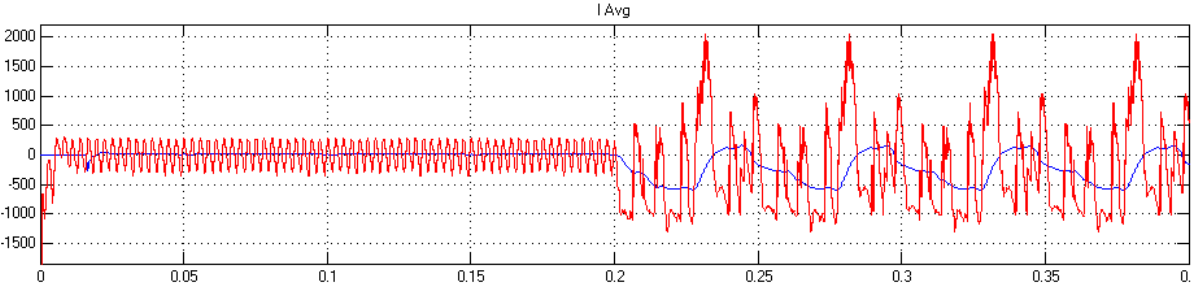

Figure 55 Battery charging current with faults in generator and thruster 1

Figure 56 show the current through the large resistance between the neutral point and ground. It can be seen that it remains very small at the second fault. This is because the resistance is still very big, and the fault current choose to travel the path with the least resistance, which in this case is through the two faults in the thruster and generator.

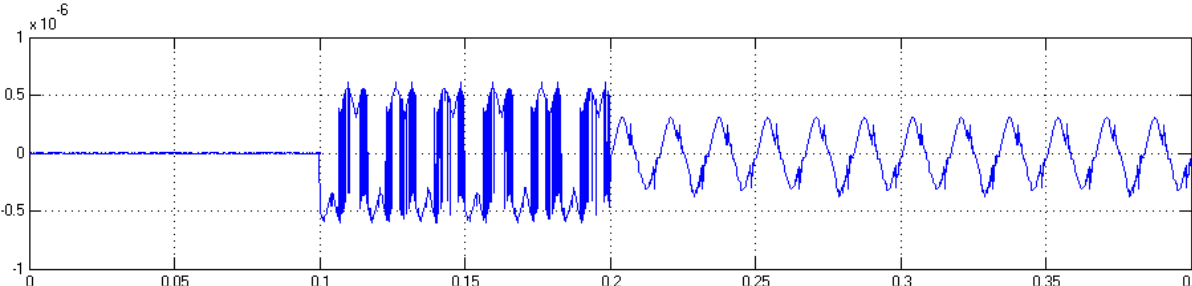

Figure 56 Current from neutral point of generator to ground with faults in generator and thruster 1

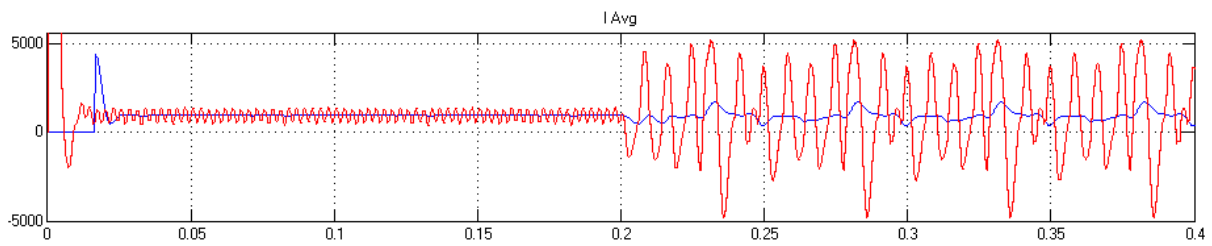

Figure 57 Current in DC feed cable with faults in generator and thruster 1

Figure 57 show that a fault in one part of the system will affect another healthy part of the system. This figure shows the current through the DC feed. The current pulsing back and forth between the Siemens bus and the external bus is caused by the charging and discharging of capacitor banks. This again occur because of the unstable voltage on the bus.

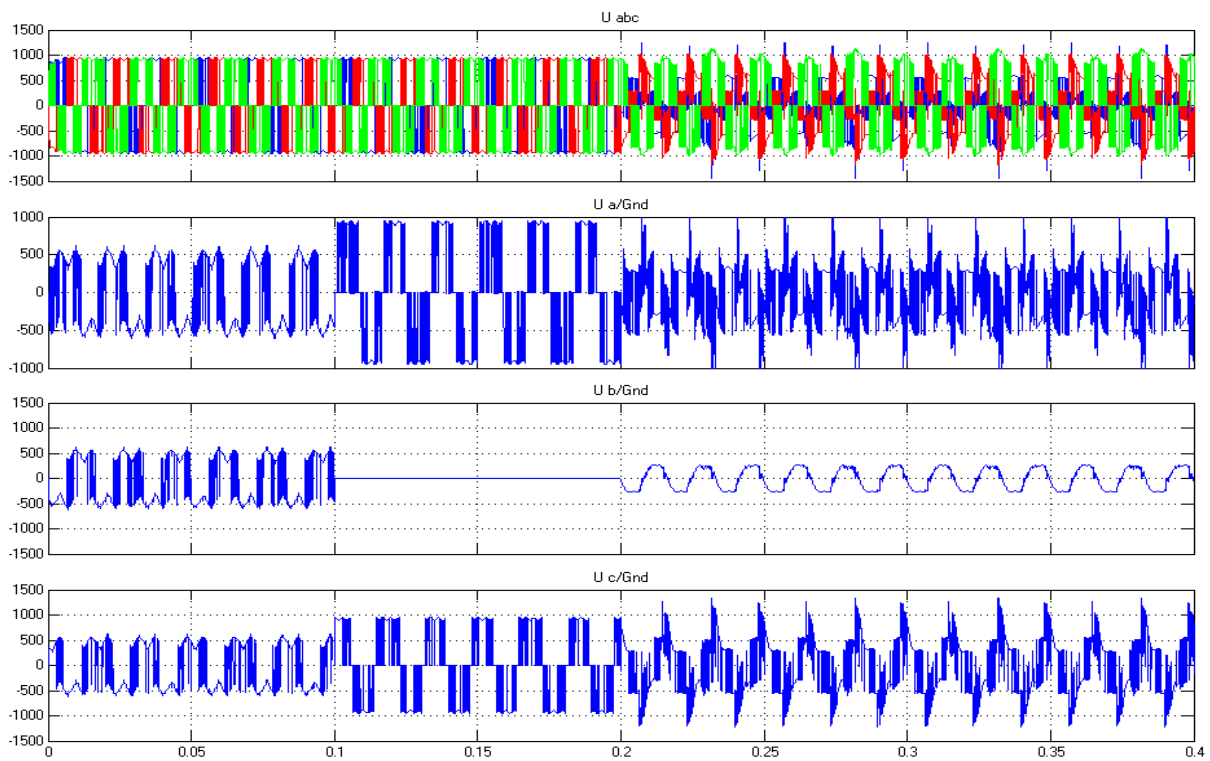

Figure 58 Voltage between phases and ground on thruster 1 with faults in gen. and thruster 1

Figure 58 show voltage measurements between the phases, and phases to ground at thruster 1 terminals. It can be seen that the voltage between the phases is affected by the second fault. The voltage between the phases and ground show how the fault at phase b affects the other phases and causes voltage spikes above 1000 volts.

Figure 59 show how the current, voltage and power of the thruster are affected by the fault. It can be seen from the figure that the voltage on phase a and b is slightly reduced. This causes the current and thereby the power to become reduced. From this information, it can be understood that the performance of the thruster is affected by the second fault. In a normal situation, the safety function in the inverter would stop the power flow to the faulty load. The large current would also trigger the fuse that would reduce the fault current. In some cases the inverter is able to stop the fault current before the fuse is melted.

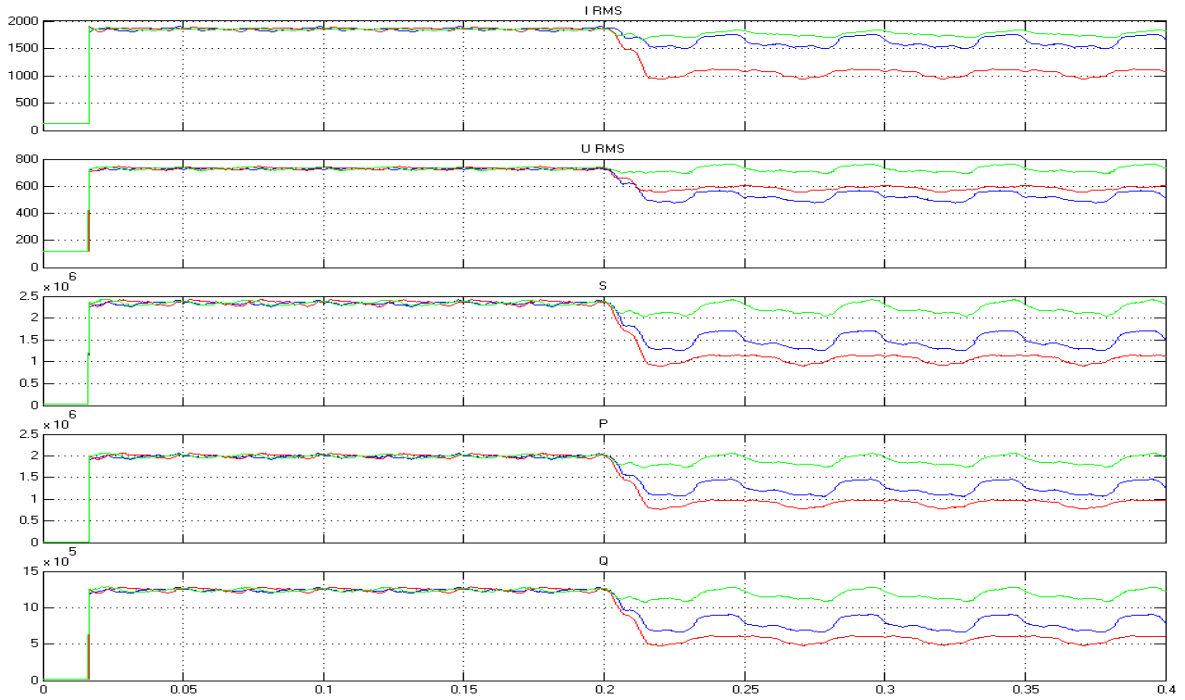

Figure 59 Current, Voltage and Power on thruster 1 with faults in generator and thruster 1

Figure 60 show the current, voltage and power measurements of engine 6. Because of the unstable voltage level on the DC bus, the voltage, current and thereby power becomes unstable for the engine. This operation condition is not good for the load and may cause unstable operations. Similar results can be seen from other healthy components in the system.

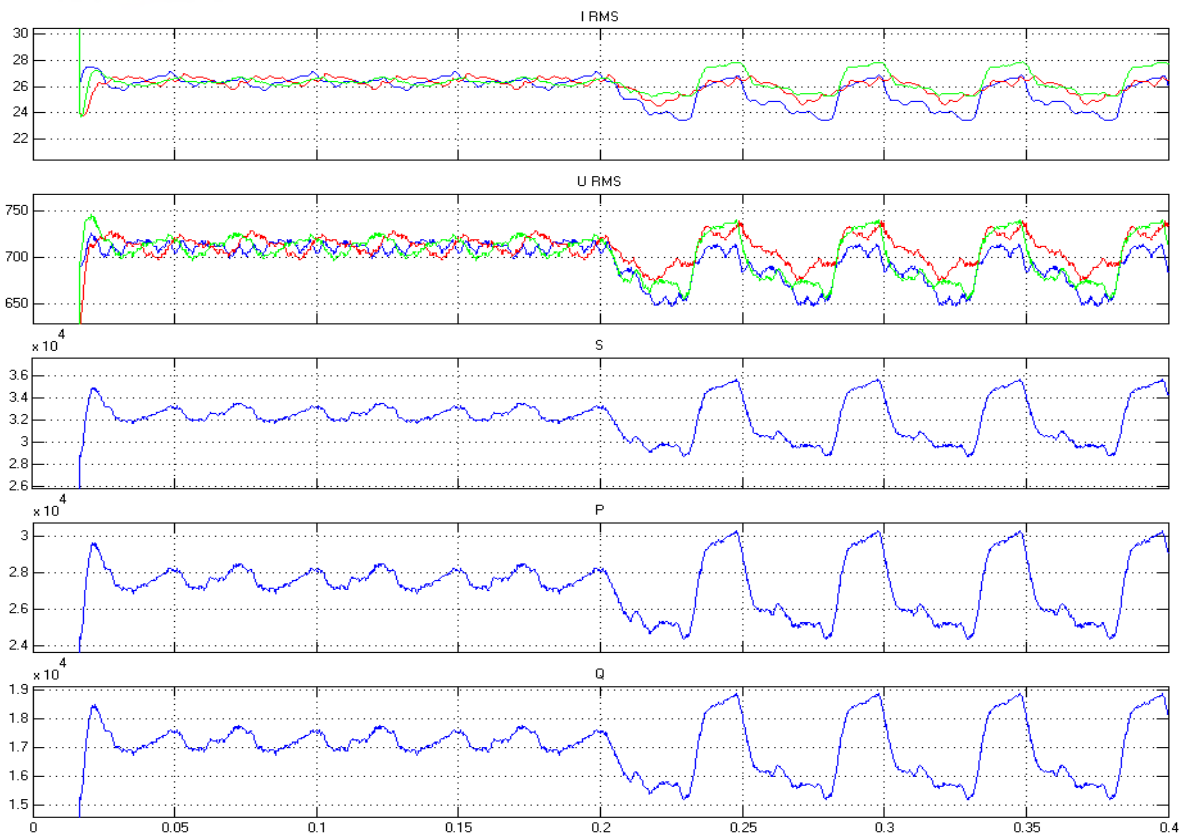

Figure 60 Current, voltage and power of engine 6 with faults in generator and thruster 1

### 4.2.3 Ground fault on DC bus in combination with ground fault in Thruster 1 or Engine 6

The purpose of this simulation is to illustrate how a second ground fault in a small load connected to an external bus will affect the system compared to a second ground fault in a large load connected to the main Siemens bus. The simulation is made by creating a constant ground fault between the negative pole on the external DC bus and ground. Then a second ground fault in engine 6 is created for 0.2sec. When the fault in engine 6 is cleared and the system is stabilized, a new second fault in the thruster is made. This is done in order to easier compare the results from the fault scenarios, and to save space in the report. The simulation have been executed as follows: The system operates in normal state from 0sec. At 0.1 sec, a fault with resistance path of 0.001ohm is made between the negative phase of the external DC bus and ground. Then a second fault with resistance path of 0.002ohm is made in Engine 6 at 0.2sec. This fault is cleared at 0.4sec. The system then gets 0.1sec to stabilize before a new second fault is created in thruster 1. This fault is created at 0.5sec and has a resistance path of 0.002ohm. Figure 61 and Figure 62 illustrate the placement of the fault generators in this simulation.

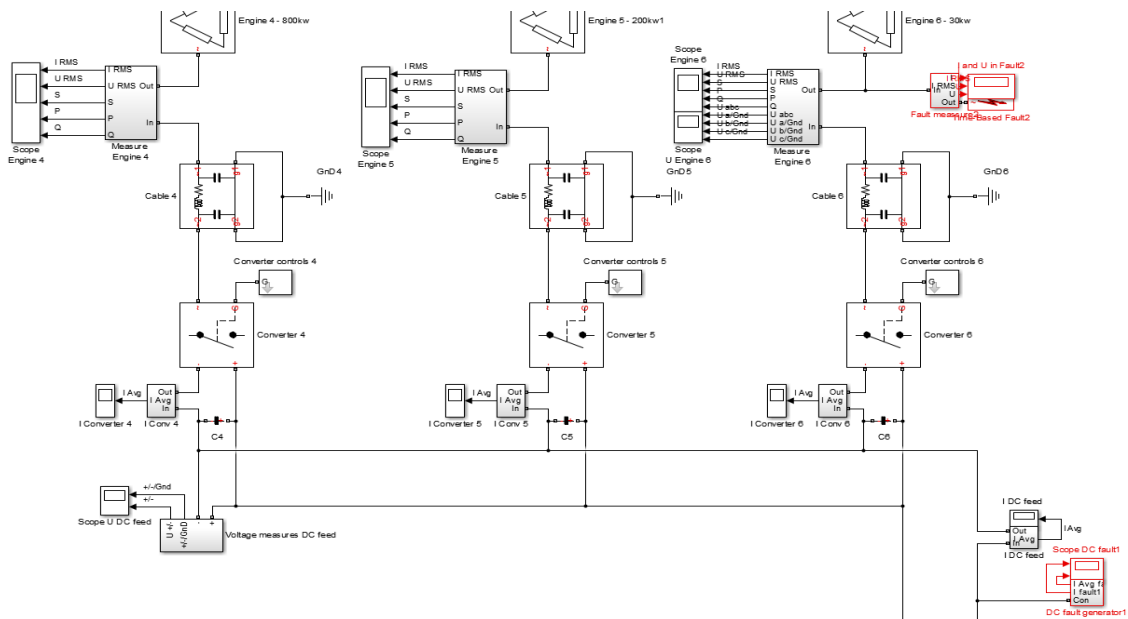

Figure 61 Illustration of placement of DC fault generator, and the fault generator at Engine 6

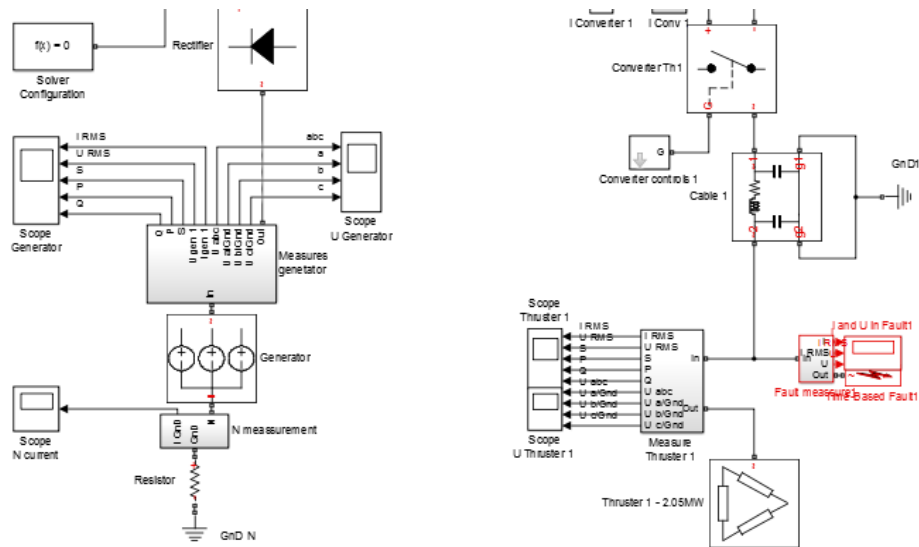

Figure 62 Illustration of placement of fault generator for thruster 1

The only place both fault currents pass through is the first ground fault at the external DC feed. Figure 63 show the fault current through the fault generator placed between the negative phase on the external DC bus and ground. It can be seen that there are almost no fault-current at the first ground fault between 0.1 sec and 0.2 sec. At 0.2 sec, the second ground fault in the small 30kW engine is generated. The fault current then becomes about 3.5kA. The ground fault in engine 6 is then cleared, before the fault in the thruster is generated at 0.5sec. From the figure, it can be seen that this new second fault in the thruster generates a much larger fault current. The current now increase to about 50kA. This fault current is more than 14 times larger than the fault created in the small engine.

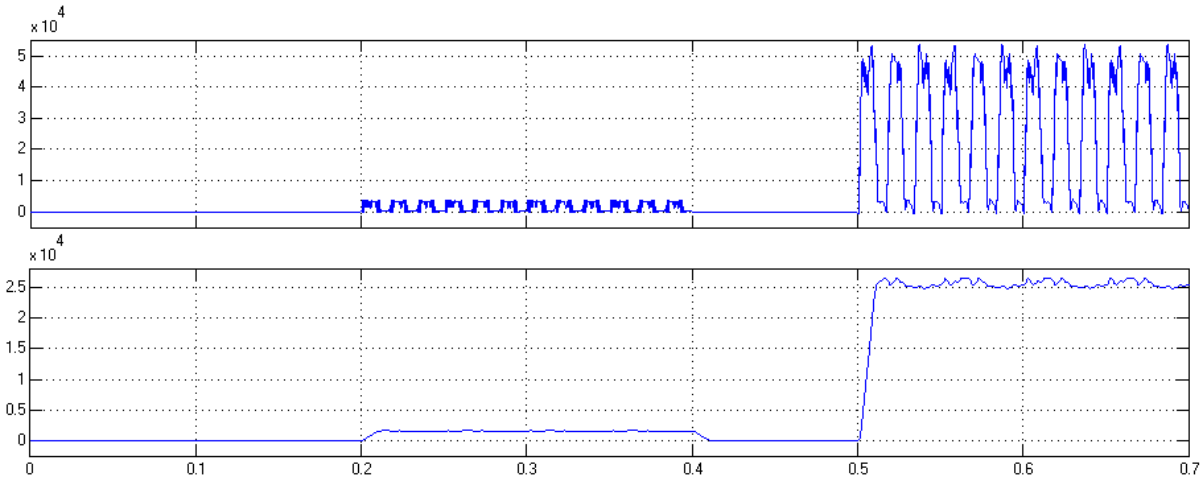

Figure 63 Current in DC fault generator at the ext. DC bus with fault in DC bus, eng. 6 and thr. 1

Figure 64 show the current, voltage and power readings from the generator. The measurements also show that the increase in fault current is much larger if the second fault occurs in the thruster compared to the small engine. At normal operation, the apparent power output from the generator is about 7.5MVA. When the second fault in engine 6 occur, the power output increase to about 9MVA. This represent an increase of power consumption of just above 20%. When the fault is created in the thruster at 0.5sec, the power consumption increases to about 34MVA. This represent an increase of power consumption of above 350% compared to the nominal load. In a real system with dynamic behavior, the impact of the fault in the thruster would be more harmful than the one in the small engine. The fault in the engine would probably be manageable for the system. In addition, the system would clear the fault very fast if it had occurred in an actual system. Figure 65 show the current output from the rectifier. The readings from this graph supports the power readings of the generator and show a much larger current output for the fault at the thruster compared to the fault in engine 6.

The current to the neutral point of the generator is still very small because of the large resistance between the neutral point and ground. Figure 66 show the current measurements through the neutral point of the generator. There is a very small difference between the one phase fault that occur at 0.1 sec and the second fault in engine 6. When the fault in the thruster occur, the current ripple through the neutral point increase drastically.



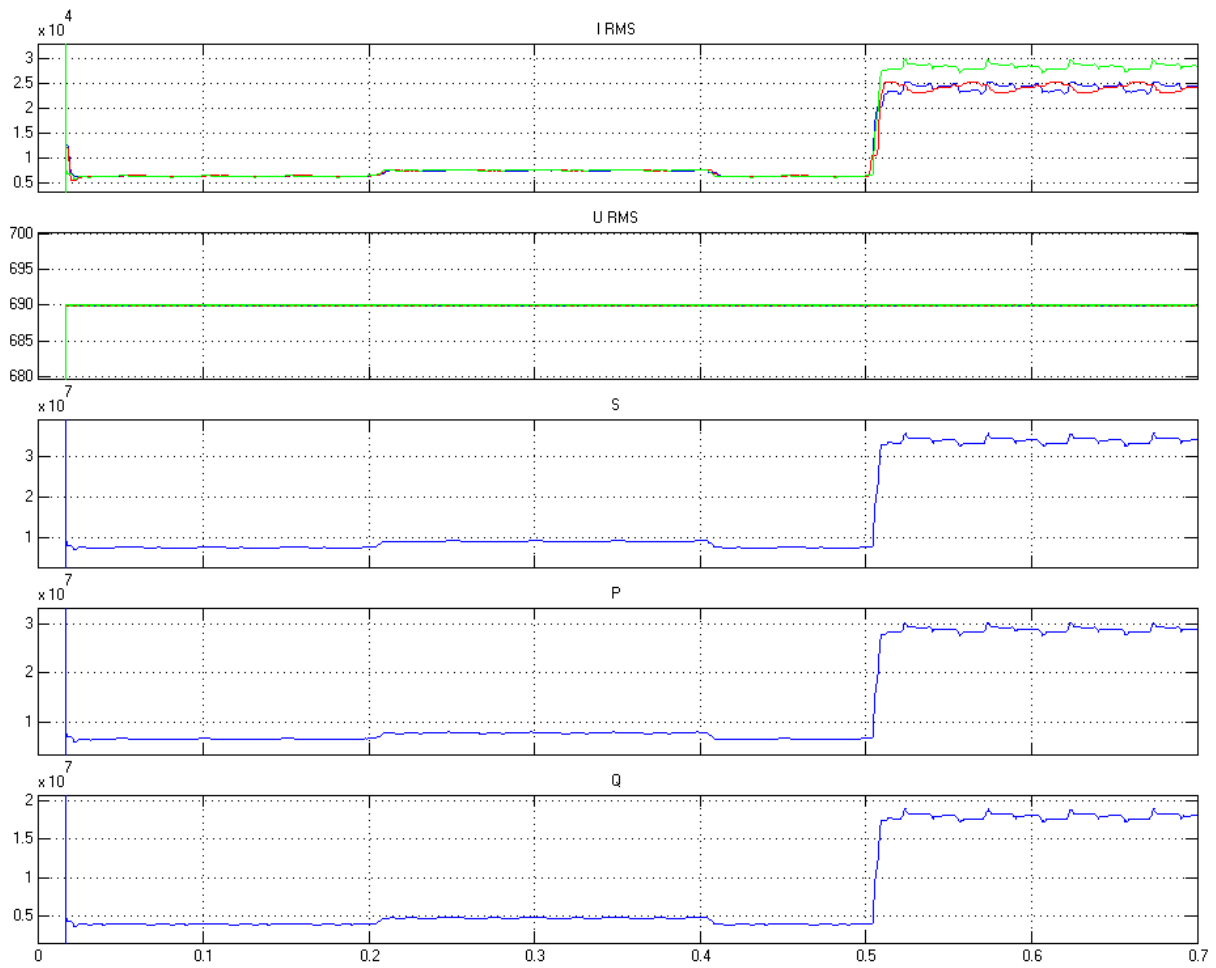

Figure 64 Current, Voltage and power at generator with fault in DC bus, engine 6 and thruster 1

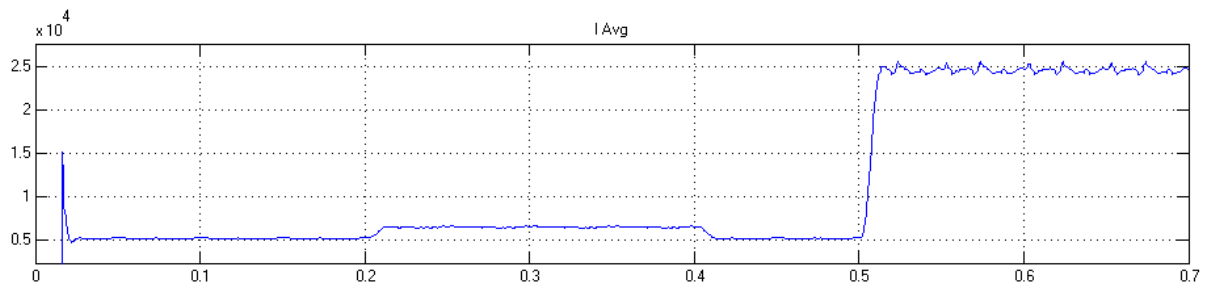

Figure 65 Current through Rectifier with fault in the DC bus, engine 6 and thruster 1

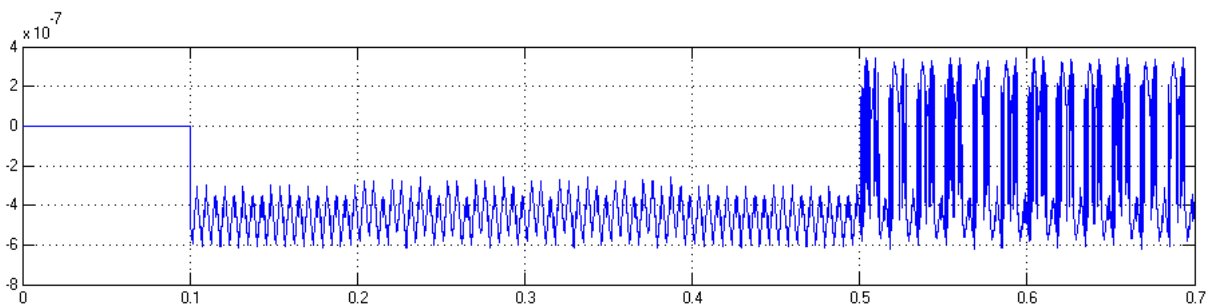

Figure 66 Current through N-point of generator with fault in the DC bus, engine 6 and thruster 1

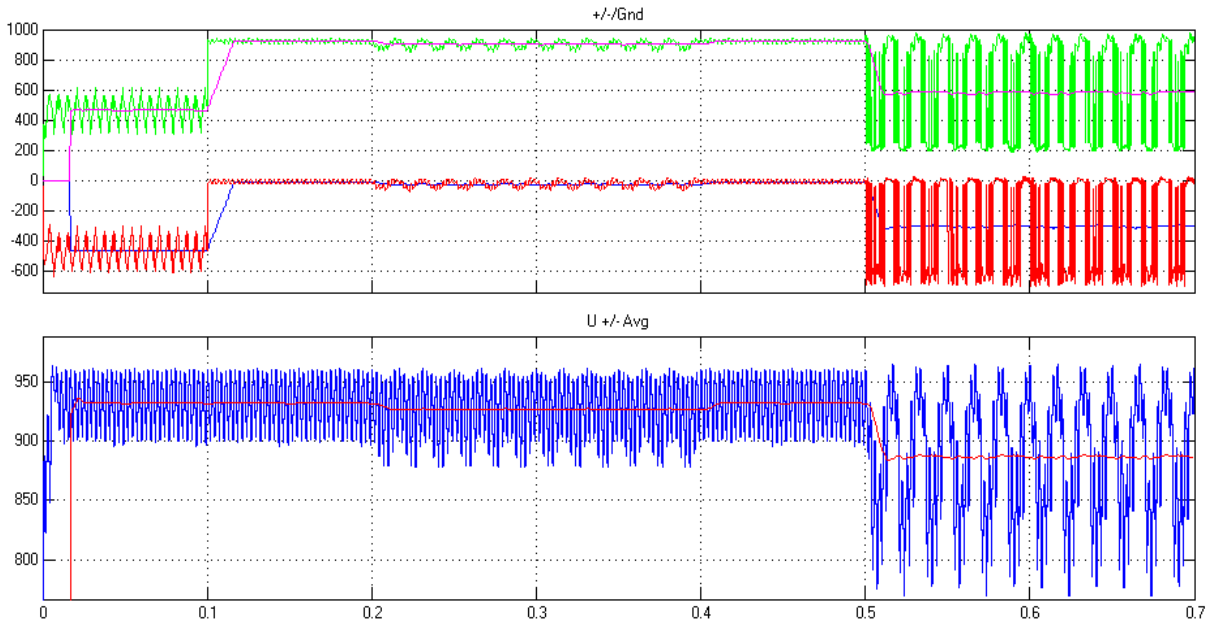

Figure 67 Voltage at Siemens DC bus with fault in the DC bus, engine 6 and thruster 1

In order to evaluate the influence the fault has on the system, the most important measuring point is the voltage at the Siemens DC bus. This is because this is the main power distribution point of the system where all components are connected. An instability in this point will affect the entire system. Figure 67 show how different faults affect the voltage level on the Siemens bus. It can be seen that the initial fault at 0.1 sec only affect the voltage between phase and ground, and not between phases. This is expected from analyzes in chapter 4.1. The second fault in engine 6 at 0.2 seconds causes the voltage between the two phases to become slightly unstable with a larger ripple than in normal operations. The average voltage on the bus is reduced with about 6 volts. The fault in the thruster however causes a much larger impact on the system. The voltage in this case become very unstable with a ripple of up to 200V. The average voltage on the bus drop to about 887V which is a drop of about 45 V. In a real dynamic system, this voltage drop would be much worse because of the generators inability to maintain the power output.

Since the charging current of the battery is directly linked to the voltage on the Siemens bus, the charging current of the battery follows the ripple between the phases. Figure 68 show the charging current measured in the batteries. When the fault in the thruster occurs, the discharge current reach a peak of over 1500A. This current is very large and could damage the batteries in short amount of time.

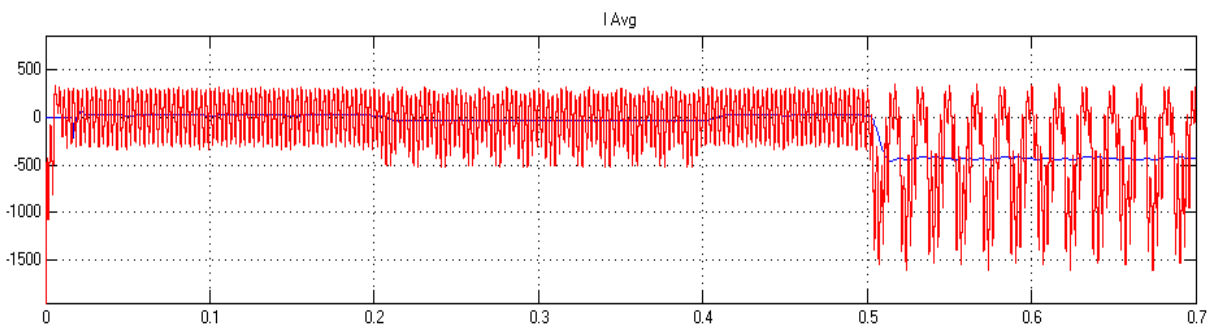

Figure 68 charging current in battery with fault in the DC bus, engine 6 and thruster 1

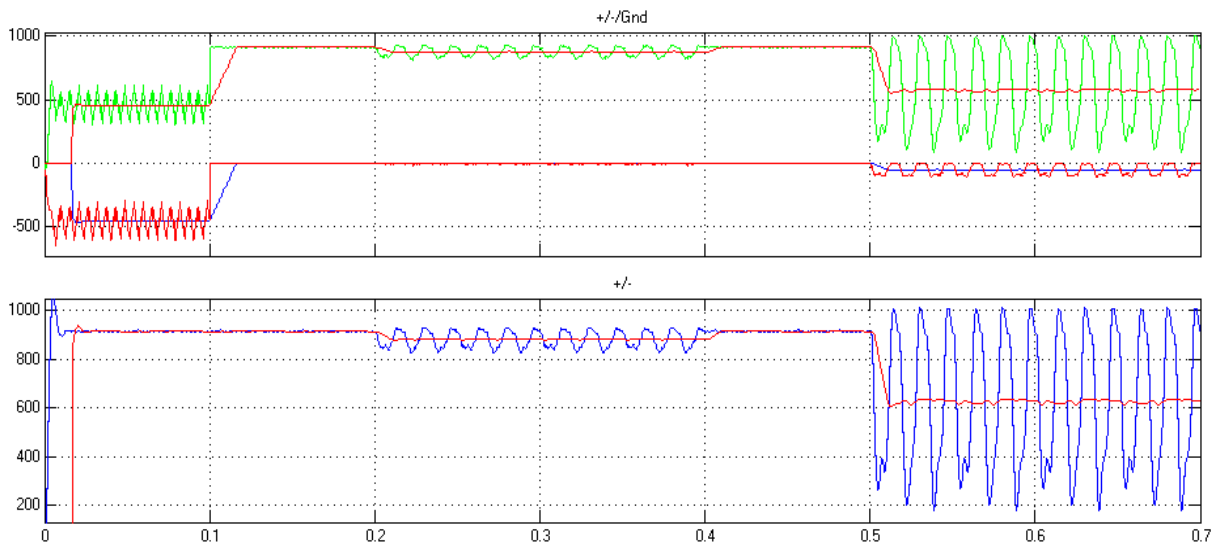

Figure 69 Voltage at the external DC bus with fault in the DC bus, engine 6 and thruster 1

The measurements of the external dc feed show that the two different second faults will affect the dc-feed to a greater extent than the more rigid Siemens bus. In Figure 69, the voltage at the external dc bus can be seen. Since the fault in engine 6 is directly connected to the bus, it is not very surprising that this fault affect the external dc bus in a larger manner than it affects the Siemens DC bus. The voltage ripple during the fault in engine 6 is about 100 V with an average voltage drop of about 35V. As the first ground fault occur on the external dc bus, the fault in the thruster affect the external dc bus significantly. The voltage ripple is now about 800V with an average voltage drop of about 285V.

Current through the DC feed show how the contribution from the Siemens bus is to the faults. The average current through the dc feed during normal operations is about 950A. When the fault in engine 6 occurs, the average current through the dc feed increase to about 2300A. This is an increase of over 140% in current throughput. When the fault in thruster 1 occur, the current becomes much larger with a peak value of over 50 kA and an average current through the dc feed of just above 26kA.

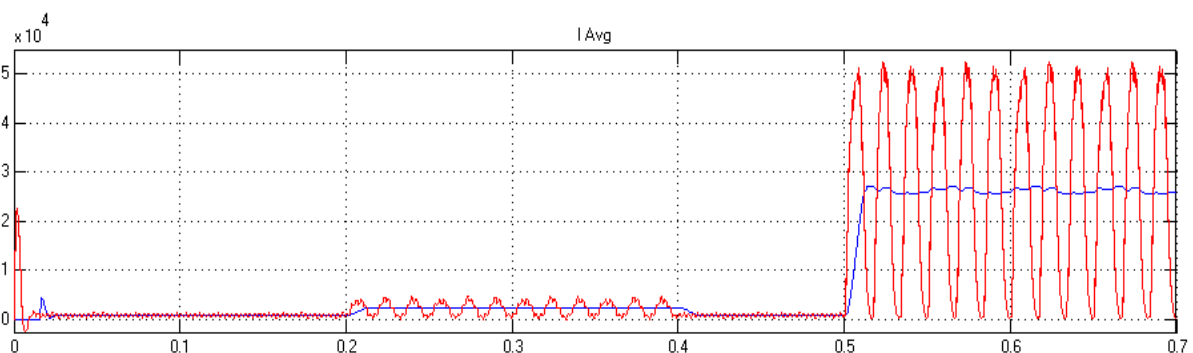

Figure 70 Current through external DC feed with fault in the DC bus, engine 6 and thruster 1

The current readings of converter 6, which is connected to the faulty engine, show that when the fault in engine 6 occurs, the current starts flowing from the AC side of the converter to the DC side. This shows that the fault current chooses to go from the DC fault on the bus, through the converter and back to the other phase on the dc bus.

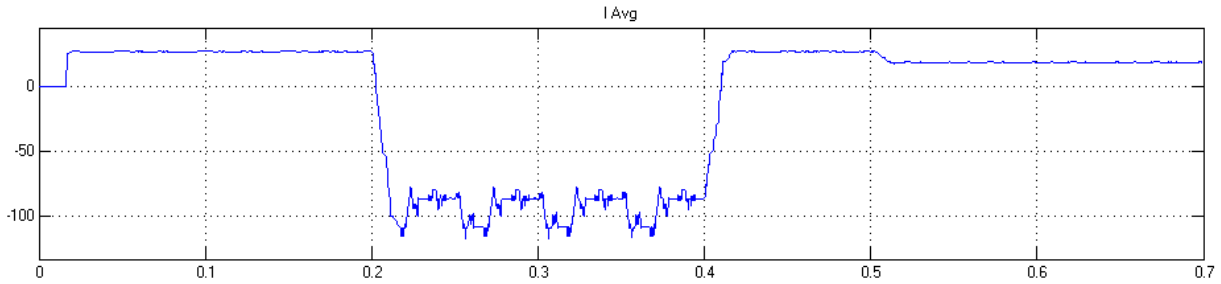

Figure 71 Current in converter 6 with fault in the DC bus, engine 6 and thruster 1

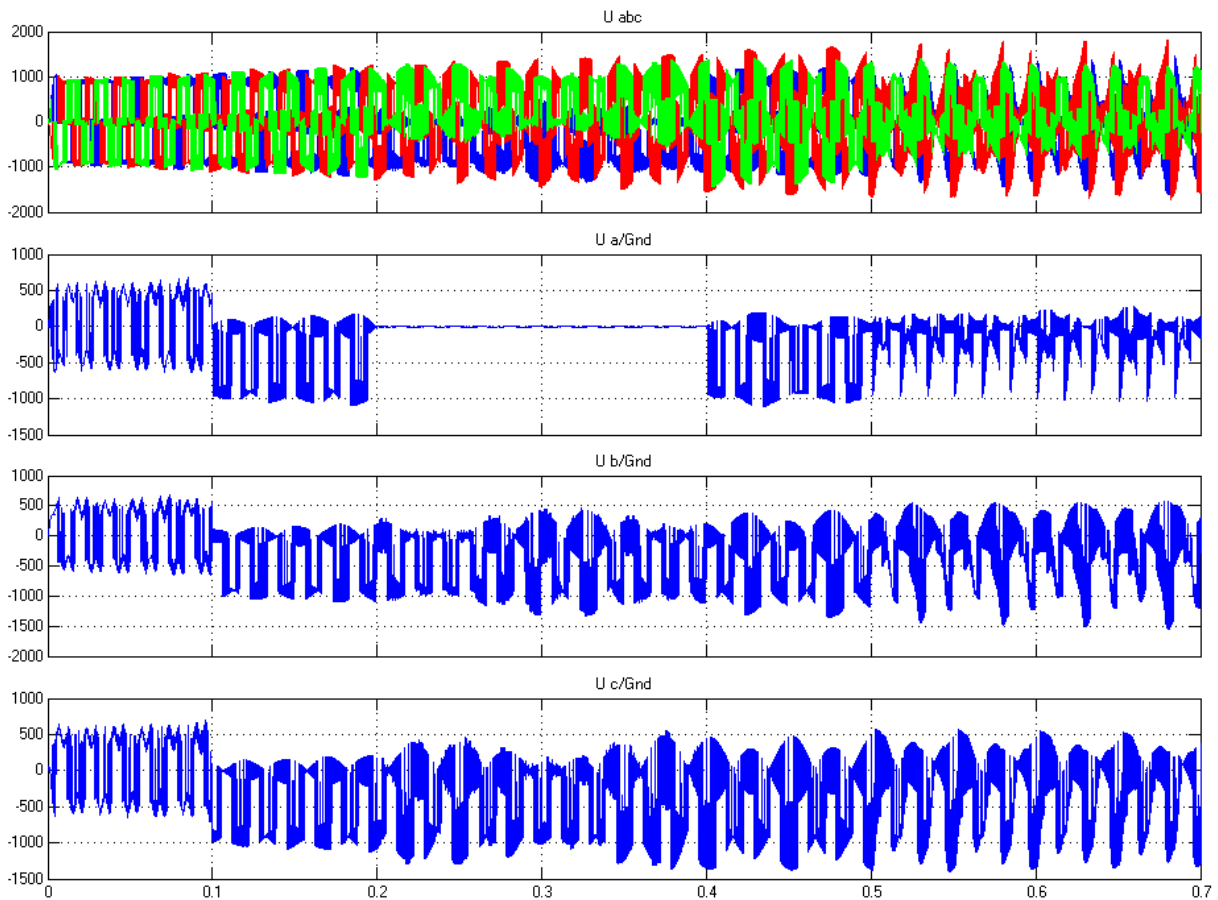

Figure 72 Voltage measurements at engine 6 with fault in the DC bus, engine 6 and thruster 1

Voltage measurements from terminals of engine 6 show how the different faults affect this engine in the different fault situations. It can be seen that especially phase a which is the faulty phase in both engine 6 and the thruster have a very unstable operation characteristic. Phase b and c both decrease more than phase a, while phase an actually increase throughout the entire simulation. This can be seen more easily in Figure 73 where the voltage can be read in RMS value between the phases. Since the measuring block is placed after the fault, the fault current does not pass through the measurement block and does therefore not affect the measurements directly. When the fault occurs in engine 6, the voltage level in the engine drops. The reason for this is that the large fault current cause a larger voltage drop across the cable and inverter. Even though the fault has occurred in engine 6, the fault in the thruster actually affect the power output in a greater way than the fault in the engine. This is because of the significantly reduced voltage level on the external DC bus.

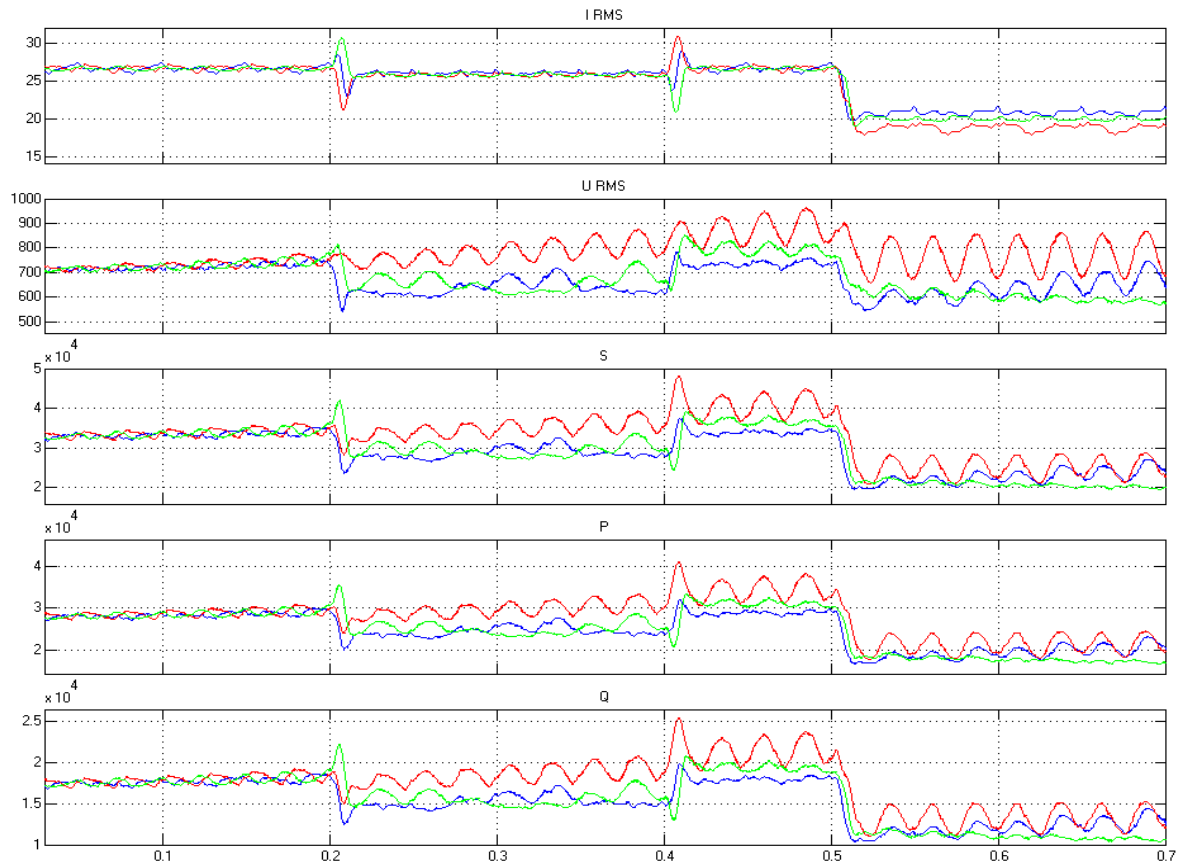

Figure 73 Current, Voltage and power at Engine 6 with fault in the DC bus, engine 6 and thruster 1

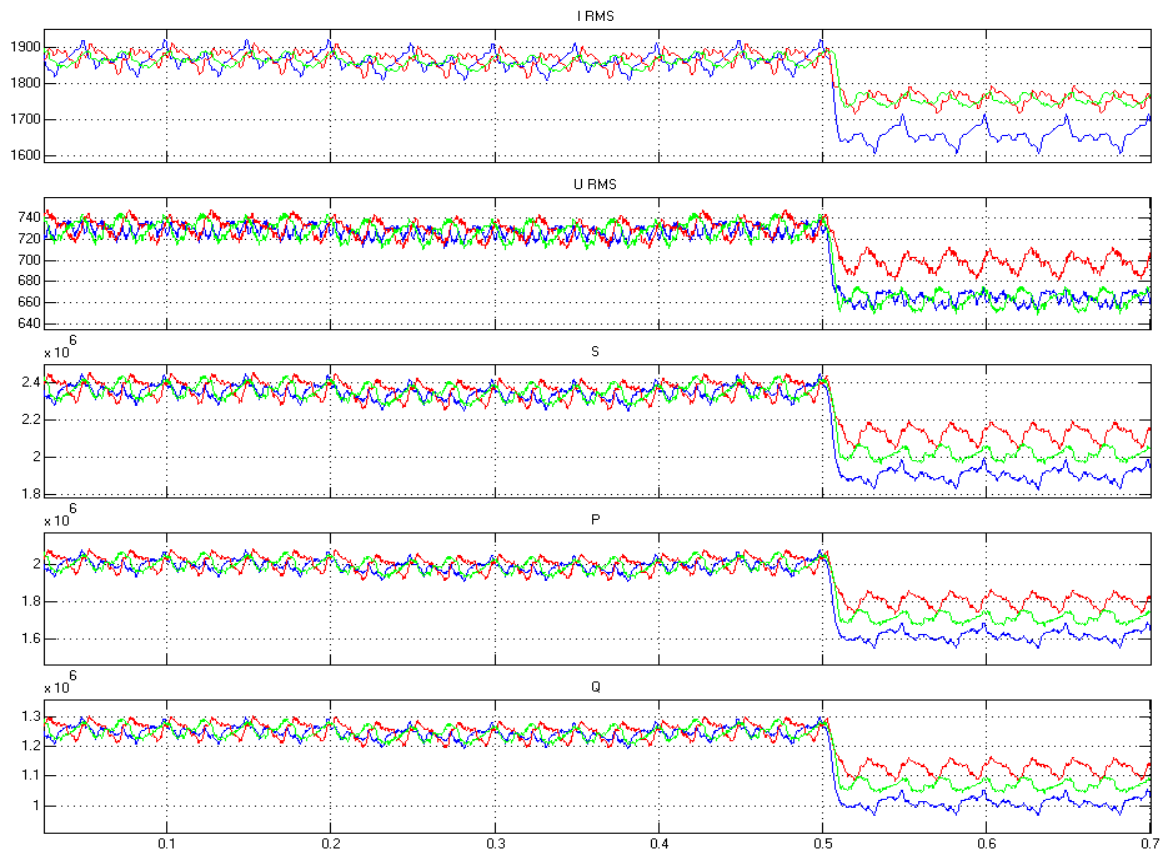

Figure 74 Current, Voltage and Power on thruster 1 with fault in the DC bus, eng. 6 and thruster 1

Figure 74 show how thruster 1 is affected by the different fault situations. It can be seen from the power measurement curve that the combination of a fault on the external dc bus and engine 6 have very little affect the thruster performance. In addition, the current consumption from the bus supports that the fault in engine 6 have a very small influence on the consumed current of the thruster (see Figure 75). The thruster consumes about 1.9kA both in normal operations and during the fault in engine 6 and the dc bus. When the fault in the thruster occur, the current consumption increase to about 22kA. This current surge is very large and should cause the fuse and safety functions of the power electronics to trip.

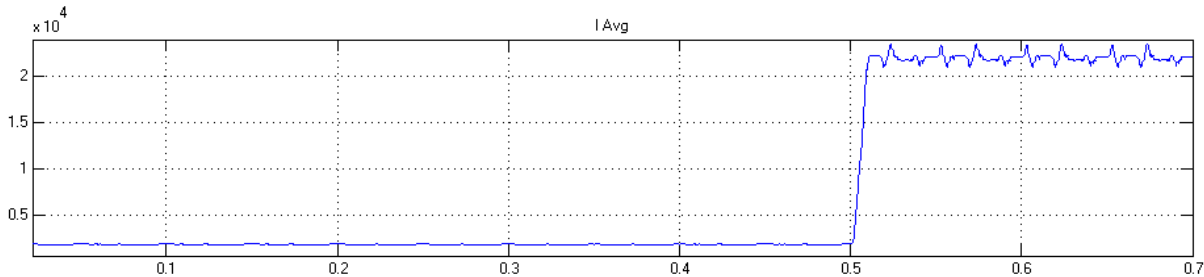

Figure 75 Current in converter 1 with fault in the DC bus, engine 6 and thruster 1

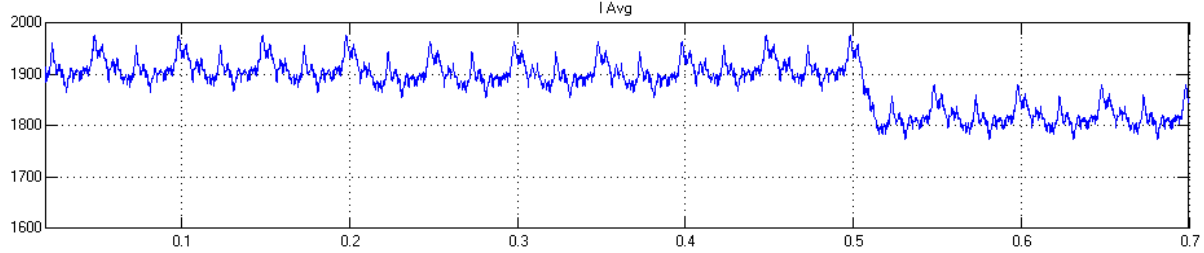

Figure 76 Current in converter 2 with fault in the DC bus, engine 6 and thruster 1

An easy way of analyzing how a load is affected by a fault is to see how the current consumption from the dc bus is affected as the faults occur. Figure 76 show how a large load like thruster 2 is affected by the different faults. It can be seen that the fault in engine 6 at 0.2 sec has almost no effect on the large thruster load connected to the Siemens bus. On the other hand, the fault in thruster 1 gives a significant effect on thruster 2 that is connected to the Siemens bus.

A similar comparison has been made for the largest consumer at the external dc bus. Engine 4 is an engine of 800kw. In normal operations, it consumes about 720A from the DC bus. Figure 77 show that when the fault in engine 6 occur, the current consumption decrease to just under 700A. The fault in thruster 1 however reduce the consumption to under 500A. From this information, it can be seen that even though engine 4 is connected to the same dc bus as the faulty engine 6, the impact of the fault is limited. The fault in the large consumer however, has a much larger impact on the system in general.

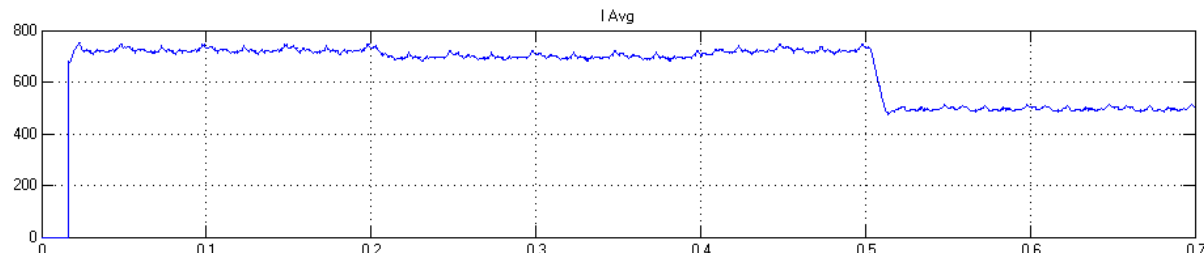

Figure 77 Current in Converter 4 with fault in the DC bus, engine 6 and thruster 1

## 5 Locating and handling ground faults in Shipboard DC power system

When a ground fault occur, it is usually quite easy to detect that it is present. It is however much harder to locate the fault when it is discovered. When the insulation have a resistance value of less than 1Mohm, it is usually considered a ground fault. A ground fault is in this thesis considered to have a lower ground path resistance than 20kohm. Isolation resistance between 1Mohm and 20kohm is detected and alarmed. Localization is normally done manually, and take a lot of time. In a ship with a DC bus and DPS-3 requirements, it is important to locate and clear, or limit the chance of a second ground fault. Even if the system were able to automatically locate the fault, it is not granted that it has the opportunity to clear the fault. The fault may have occurred on a component used in an operation that cannot be interfered in all situations. The system then need to reduce the probability of a second fault occurring. The system can reduce the chance of a second fault by isolating the faulty bus from the other busses. If a fault then occur in any of the other three busses, it will not create a closed circuit.

Chapter 2.6 quickly explains some of the most common ways to detect and locate ground faults in power distribution systems today. Most of the methods explained require that service personnel manually need to locate the fault. This process can be very time consuming in large systems. In some cases it can also prevent normal operation of the system until the fault is found and cleared (this should not be possible in DPS-2 and 3 class vessels). This chapter focuses on how the system can be automated in order to detect, localize and then clear the fault or reduce the chance of a sub-sequent fault occurring.

A short evaluation of a solution with TT grounding system where the neutral point is grounded via a resistance with a pre-defined value is also considered.

### 5.1 Ground fault localization in IT grounding systems

In this chapter, fault detection methods used in IT systems with no or high resistance grounding of the neutral point is being presented. First, some localization techniques used in AC systems have been evaluated towards its usability in a DC grid. Then a promising automatic localization technology, which is in research and found in IEEE, is presented. A presentation of a commercially available system is finally presented in order to present a system that is available on the market today.

#### 5.1.1 Fast Fourier analysis

An example of a localization method that can be used in AC systems is to use a signal source to momentarily apply a signal over a wide frequency band. A signal processor then apply fast Fourier transformation analysis in order to utilize the system impedance over a wide frequency band. The advantage with this technique is that it is able to monitor the isolation impedance over a large range of frequencies. However, the high frequency noise caused by the switching transients may prohibit good reading of the impedance signal. This will further cause trouble in locating the fault location. This technique need an extra signal generator separated from the signal processor.

#### 5.1.2 Traveling wave analysis

Traveling wave analysis is a commonly used ground fault location technique in large power systems. The challenge with this technique is that the system on the ship is not as widespread as large power distribution systems. Because of this, the time difference between the arrival of an incident wave and the arrival of its reflection from the bus bar will be too short to detect the waves separately with good enough certainty. In addition, the mesh-like structure of the ships power distribution busses makes it hard to apply this technique successfully.

### 5.1.3 Localization by noise analysis from power electronic converters.

As seen in simulations in chapter 4 the phase-to-ground voltage between a faulted phase on both AC and DC side collapse to zero in case of a ground fault. In the same time, the phase to ground voltage on the healthy phase(s) changes accordingly in order to maintain the correct phase-to-phase voltage. Exploiting this phenomenon, detecting the presence of a ground fault can be accomplished relatively simply by measuring the phase to ground voltage. In combined AC and DC systems, a significantly amount of noise is generated by the repetitive switching introduced by the power electronic converters. In case of a ground fault, this high frequency background noise contain characteristic information of the fault location. Different fault locations is associated with different noise patterns. By exploiting this fact, fault localization can be conducted without an external signal generator. The fault localization is done by extracting the characteristic information from the background noise in the system signal. A signal processor then apply advanced signal processing which uncovers an elaborate fault location solution. Using this technology, there is no use for several components places all over the system. The signal can be retrieved from both voltage and current measurements [6].

The disadvantage with this localization technique is that it is only in research. Extensive sensitivity analysis and experimental work is required to investigate the feasibility of this approach for practical applications. The technology is however promising, and have shown that it is possible to effectively utilize the noise caused by the inherent switching actions of the power electronic converters. Results from early research show that significant noise patterns can be extracted by adequate signal processing methods to allow fault location from a single signal measurement point. In the case of a ship with four busses however, one signal detector need to be connected to each bus [6]. Further information on this technology is presented in an IEEE report: [6].

### 5.1.4 Bender ground detection and location system

Bender is one of the largest producers and suppliers of industrial ground fault and detection systems. Siemens already use their detection and location systems on ships in operation today. Bender offers a wide range of ground fault detection systems for IT, TT and TN grounding systems. Some of their detection systems support fault detection in both AC and DC systems, and is claimed to work smoothly with power electronics like VSD and ASD.

Benders detection system uses an active Insulation Measurement Device (IMD), which can be considered at an online megger. The IMD sends out a constant measuring signal through the main power wires that is evenly distributed throughout the system. If the signal encounters a point in the system where the insulation has been weakened, the signal will follow the path of least resistance back to the monitor. The IMD will then process the signal to find how damaged the insulation is. At a pre-defined resistance level, the IMD trips a pre warning or a ground fault warning. The two levels can be defined for each system. The system does not consider how large the leakage current in the system is. It only measure the strength of the insulation. The IMD system measure faults in ohm and not ampere. The working principle of the system in a DC distribution network is the same as for AC distribution systems.

Ground fault localizing in ungrounded systems can be done via fixed installation in addition to using portable devices. Some detection systems also support both detection methods in one. The methods for locating ground fault in a grounded system (TT/TN) compared to an ungrounded system (IT) are based on different techniques. In grounded systems, the localization is done via a multi-channel ground fault relay utilizing current transformers to notice leakage current for each individual circuit or load. In an ungrounded system, the first fault will not have large enough leakage current to discover where the fault is located [7].



A controlling device with a pulse generator is placed upstream in the system. This device sends a low-level artificial signal into the faulted system. The signal is injected between the power lines and ground. It then follows the shortest way from the power wires, through the point where the insulation is damaged and back to the pulse generator. The signal can then be traced with fixed current transformers placed at strategic places in the system. The signal can also be traced by using a special portable current probe. This localizing system can be used while the system is online. The ground faults can be located to the load causing the problem while the system remains in operation. The accuracy of the automatic localization is dependent on how many fixed current transformers are linked together in the system [7].

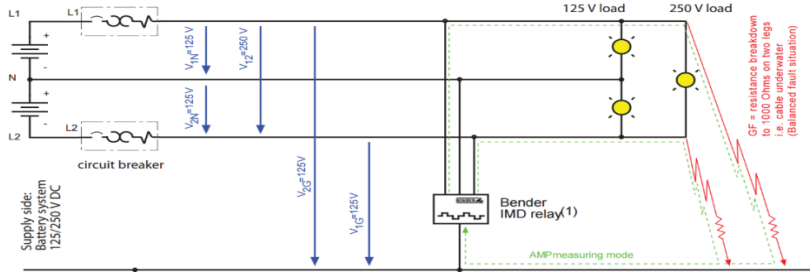

Figure 78 Illustration of the working principle of the IMD relay

The fixed installations with several connected differential transformers are needed in order to automatically respond to fault situations. Automatic localization gives the system an opportunity to clear the fault or at least take action in order to reduce the probability of a sub-sequent ground fault. If the fault occur in a component that cannot be disconnected, the automatic localization system give a head start as to which circuit is causing the problem [7].

The bender system consists of three main components: ISOMETER ISO 1685P, EDS460 or EDS 490 Ground Fault Location Devices and W series current transformers. The ISO 1685 monitors for ground fault by measuring the system’s insulation resistance. The device can be combined with EDS460 or EDS490 ground fault location devices and the W series differential transformers. The ground fault locating system is only activated when a ground fault is detected. Two-way communication is carried out between devices via RS-485 interface. The interface can also be converted into other protocols such as Ethernet, MODBUS or PROFIBUS using a converter. Figure 79 illustrate how Bender ground fault location can be executed. The ISO 1685 is also able to log the state of the system and store it on a memory stick that can be used to analyze system behavior [8]. In the illustration in Figure 79 the ISO 1685P is replaced with the component called IRDH575 at DC voltage levels above 575V.

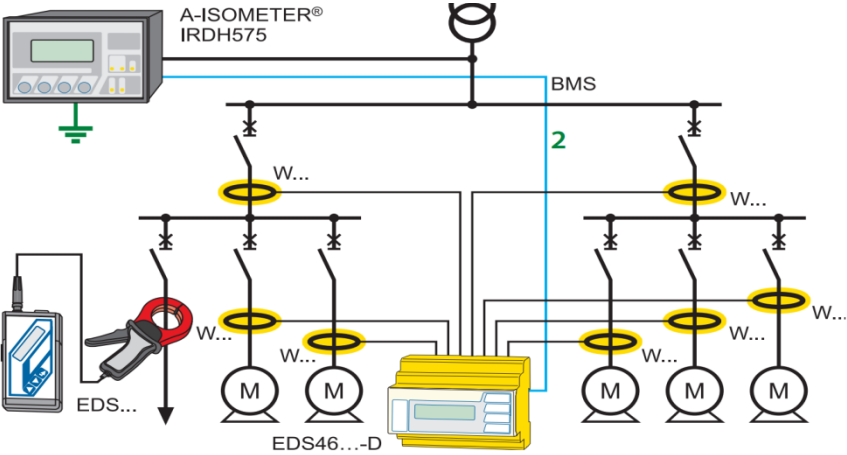

Figure 79 Illustration of Bender ground fault location system [7]

## 5.2 Suggestions for placing of current transformers for location of faults

Some current transformer schemes for locating ground faults are presented in the following. Even though the system consists of four separated busses, the following schemes are based on one bus specified by Siemens.

When planning the automatic ground location system, it is important to know what is important. Should the system be able to automatically locate the fault as accurate as possible down to the faulty load at the price of higher complexity and cost, or should the system be planned based on other factors such as price and complexity. Systems with lower ability to automatically locate faults will further demand more manual searching in order to locate faults. The localization and measures is assumed started when the isolation resistance can be considered as a short circuit to ground.

### 5.2.1 Solution with good ability to automatic locate faults

Figure 80 shows how the system can be planned if the main goal is to locate and eventually clear the fault as soon as possible. This solution can be implemented in an automatic fault handling system capable of evaluating if the faulty component can be disconnected shortly after the fault have occurred. From this information, the system could decide if the component should be disconnected or if it should just sound an alarm advising the operator. In this case, the technicians may be able to read the location of the fault and save a lot of time in searching for the fault. This setup also give a large advantage if a transient fault situation occur, because the automatic location system is able to log where, when and how often the ground fault occur.

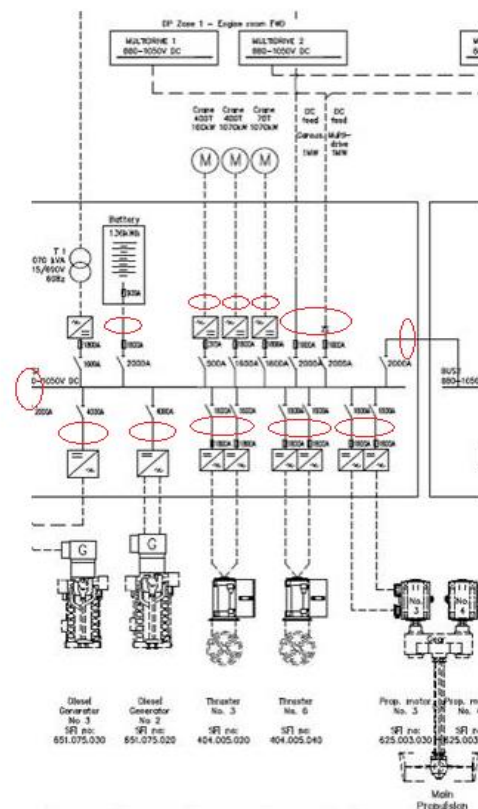

Figure 80 Illustration of ground locating scheme where system can precisely locate fault

### 5.2.2 Solution with limited ability of detecting fault location

The minimum localization capability of the system should be the ability to identify which bus the fault is connected. Figure 81 show how the minimum requirement of ground fault locating differential transformers needs to be placed on each bus. This localization strategy makes the system able to identify on what bus the fault has occurred. It is also able to locate if the fault have occurred on an external bus or the Siemens bus. It is not able to identify the faulty component or load. Further localization need to be done manually. The advantage with this solution is that since the system know what bus a fault have occurred on, it is able to take actions to reduce the probability of a subsequent fault. The system can then choose to open the bus-tiebreakers and isolate the faulty bus. This action will make sure that a fault in any other bus will not create a closed circuit between the phases.

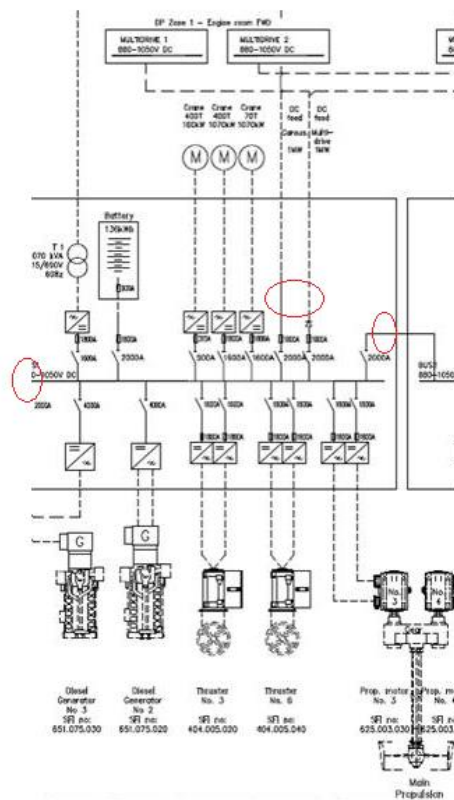

Figure 81 Illustration of the least amount of transformers for the system to act on ground fault

### 5.2.3 Solution with medium localization capability

A third option with a combination of the two systems mentioned above can also be considered. An evaluation of the probability that a ground fault will occur can be done for each component. It is a safe assumption that a fault in a generator or a large load is not as likely as a fault in smaller loads. If a component is expected to fail only once or twice in the ships lifetime, it is no need for automatic localization as long as the fault can be located to the correct bus. If the fault occurs on the Siemens bus, it should be isolated from the external bus as soon as the fault is detected. When the Siemens bus is isolated, the probability of a second fault on the same bus is very small. Most components connected directly to the Siemens bus is large components with high quality, therefore the largest challenge is ground faults on the external DC bus. In this case, demands of ground fault localization or other preventive measures on more vulnerable components on the external bus must be considered. See chapter 0 for closer analyze of demands on the external DC bus.

### 5.3 Ground fault location in TT grounding system

A solution with a TT grounding system where the neutral point of the generator is grounded via a resistance with a pre-defined value can be an alternative. This solution allows a larger fault current to flow through the ground fault. Kirchhoff's law says that the sum of currents flowing into a node is the sum of currents flowing out of that node. Using a differential transformer, the sum of the currents flowing through the cable can be detected. If the sum differs from zero, a ground fault is located at that node. The drawback of this detection method is that a larger fault current could give several negative consequences. Some of these are:

- Larger fault current than 30mA is defined as dangerous to humans and should not be allowed in a system where the fault current in any event could pass through a human being.
- Larger fault current could cause the fault location to become overheated or in worst case become hot enough to start a fire over time.
- Larger fault current is more likely to create an arc that could start a fire.

Because of these drawbacks, it is requested to use a RCD in these systems. In addition, a system where several thousand amperes flow through the bus with lots of noise caused by the power electronic components, a maximum fault current of 30mA (chosen in order to stay within safe limits for humans) might be hard to discover. Because no equipment for detecting the fault current amplitude is particularly investigated for this purpose, it is hard to define if fault currents with this magnitude would be possible to discover.

## 5.4 The external DC bus

The external bus represent a big challenge in how the system should handle ground faults. There are a lot of uncertainty around how this part of the system is designed, how many, how large and how rigid the loads and inverters connected is. One of the largest problems with the external bus is that it is expected to contain a mix of some large consumers in combination with several smaller consumers. Small consumers are expected to be of a lower quality grade and are therefore more likely to be the source of ground faults. This challenge can be handled by defining requirements to the components directly connected to the DC bus. Some requirements could be:

- Ground fault localization on every component considered vulnerable connected to the DC bus. This localization could be connected together with the locating system used at the Siemens bus, or faults could be handled locally within specified demands. The advantage with this solution is that it gives the system the possibility to locate and clear fault at the external bus in addition to faults on the Siemens bus. If the fault is handled locally, the ground fault location system connected on the Siemens bus could be programmed to wait for some time before taking action. The disadvantage with this is that it would be a complex and costly system.
- Requirements regulating how small inverters that are allowed to connected directly to the DC bus. If all small inverters are swapped with one large, a power transformer could be used to transform the voltage to a voltage level where smaller engines could be used (440V engines). In the same time, the power transformer would make sure that ground faults in the small components would not affect the entire system. If only large inverters with large loads are connected directly to the DC bus, the probability of ground fault would be drastically reduced. A disadvantage with this solution is that a separate AC switchboard needs to be established. The combined extra cost is very likely to be more than the saved cost of using 440V engines. In addition, a transformer and large inverter introduce a lot of extra weight, which is not good on a ship.
- RCD (ground fault breaker) for non-crucial components could reduce the probability of a subsequent ground fault.
- Require that small inverters and loads need to be connected to current limiting reactors. These reactors are designed to reduce the short circuit current. These reactors are mainly used to save the inverters from harmful fault currents that may be able to destroy the inverter. If an inverter is destroyed, it may cause a short circuit on the DC side, further damaging other components connected to the DC bus. If the fuse however work as intended, this should not be possible. The disadvantage with using these reactors is that it will not prevent a sub-sequent ground fault from occurring, it only reduce the fault current



## 6 Analyze of grounding system for the ship

When analyzing what grounding system is more feasible for the ship in question, it is important to know what properties is most important for the operation of the ship. The three different grounding systems have different strengths and weaknesses.

The TN grounding system have the strength that it allows a higher voltage between phases. On the ship however, the voltage between phases on the AC side need to be around 690V and most large consumers use all three phases. The fact that the first ground fault in a TN grounding system act as a one-phase short circuit is not an advantage in this type of vessel since large fault currents is unwanted. It can therefore be said that the advantages of the TN system is irrelevant or on the contrary a disadvantage in this vessel.

The advantage of the IT system is that it is able to operate unaffected even after the first ground fault. The simulation in this report shows that the voltage between the phases is unaffected both on the generator side, DC side and after the inverters in the case of a single ground fault in one phase. The ground fault only affect the voltage strain across the insulation in all other connected parts of the system. This gives a large advantage in this type of vessel where it is important that the ship can operate without interference in the case of a fault. On the other side, a ground fault in this grounding system is much harder to locate. The ship has very few transformers creating galvanic separation. The fact that the potential between phase and ground on the output of one inverter is different from the same phase on another inverter is also a challenge. These facts increase the probability that a second ground fault can occur before the first is cleared compared to a vessel based on AC power distribution. Because of this, the automation system of the ship should be able to act in order to restrict the possibility of a second ground fault. Making an automated localization solution is however, a complex project that becomes more complex the more accurate it should be.

Because of this, it is interesting to look at the possibility to increase the fault current to a level where the fault could be easier to locate. A kind of TT system can be used in order to control the magnitude of the fault current. Large fault current is harmful to humans and dangerous, considering the possibility of overheating in the fault location or creating an arc that in turn could start a fire. The fault current should be limited to maximum 30mA. This value is selected because it is defined as the maximum current a human can withstand without being hurt. The resistance between the neutral point of each generator and ground need to be carefully calculated, with the capacitive currents between the cables and ground in mind. This creates a complex equation hard to verify before the vessel is in operation. In addition, there is some uncertainty of how much the increased fault current will solve the challenge of locating the ground fault in a system where power electronics create large amount of noise.

A TN system is not likely to be the optimal solution when choosing what type of grounding system the vessel should have. The main reason for this is that since the ship is designed in order to satisfy the DPS-3 class requirements, meaning that the ship need to operate normally even in a fault situation. The challenges and uncertainties of the increased fault current amplitude in the TT system also raise some doubt about the grounding systems ability to ensure a better reliability and faster fault location than an IT system. If a solution that automatically can locate the fault in an IT system is used, the IT system is considered as the best grounding system to ensure that the operational reliability in case of a ground fault.





## 7 Discussion

The report is based on a specific ship with DC distribution technology designed by Siemens Marine in Trondheim. The ship is an OCV and is designed to meet the DPS-3 class requirements. This thesis tries to address challenges regarding ground fault in a large shipboard power system with DC distribution.

When designing the simulation model, the need for dynamic components in the model were evaluated and compared to the extra challenges with stability, reliability of results, and complexity of designing a control system for the generators. It was determined that a voltage source would give sufficient results for the one phase to ground fault simulations. Because of this, the system has no droop characteristics. The voltage ripple and power capacity on the bus is only dependent on the rectifier. As long as the neutral point of the generators are virtually isolated from ground, the fault current at the first ground fault will be realistic even with a voltage source. Siemens specified that the most interesting simulations is of the first ground fault, and how it affect the system. Because of this, the simulations were performed without dynamic components in the model.

When simulating the second ground fault, the behavior of the model is not realistic. In these simulations, the voltage source output a constant voltage no matter how large the current surge is. The simulations of second ground faults have therefore only been carried out in order to demonstrate how different fault scenarios would affect the system. In an actual ship, the converters are controlled from different control systems depending on producer and purpose. The inverters will therefore not be controlled at the same frequency with the same algorithm as in this simulation model. The control systems for the converters in the model are “dumb” and are not able to consider voltage, frequency or any other parameters. It is however considered to give realistic results for the one-phase ground fault simulations. In order to simplify the readings of voltage, current and power, mean blocks and RMS blocks were used.

The simulations show that the first ground fault does not cause any changes in the voltage between phases on either the AC or DC side. The voltage stress across the insulation however is almost doubled. As long as the neutral point of the generator is virtually isolated from ground, the fault current is negligible. Because of this, the first ground fault will not interfere with normal operations of the system. As long as the battery or its controller unit does not have any reference to ground, the battery charge will not be affected by the first ground fault. This also applies to the capacitors connected to the DC bus. When simulating the first ground fault with different fault impedance, the results were very similar. These shows that on the first ground fault the impedance have little or no impact on the effect on the system.

As mentioned before, the only purpose of the second fault simulations is to show that a second ground fault anywhere else in the system will generate large fault currents. The fault potential travels across inverters and affect both the AC and DC side of the system. The simulation also show that a second ground fault on the same phase on the AC side of another inverter will give large fault currents as long as the algorithm and loading is not completely the same. The simulations of two-phase faults cannot be considered reliable since the voltage source delivers the same voltage no matter how large the current surge is. The simulations show that a second ground fault in large components give much larger fault currents than if the second fault would occur in a smaller component. A large fault current will affect the stability of the bus, and affect the operations of healthy components in the system. They will also affect the charging current of the battery and capacitors, as they feed power to the fault. It can be discussed how fast the first ground faults need to be cleared considering the system is designed in order to operate even when a short circuit occur.

Even though it is easy to detect if there is a ground fault in an IT power system, locating the fault is much harder. When a fault with low ground path resistance is detected, it is important to locate the fault. The low fault currents in IT power systems gives a challenging ground fault localization. There are several methods for locating ground faults in an IT power system. The layout and connected components of the shipboard power system in question however limits the localization techniques. On the other hand, some new localization techniques utilizes the same components that could cause trouble for other components. One localization method analyzes the unique noise form power electronic converters in order to find the fault location. This technique is however not commercially available and untested in large systems. Bender is a producer that have a commercially available fault locating system they claim will work in AC and DC power systems with large power electronic components. This producer is a well-established company that is used by among other Siemens in other ships.

If this system should be embedded, an evaluation of how its ability to locate faults, should be performed. Components expected to cause ground faults more often than others should have a fault localization transformer connected. A minimum of fault localization transformers should be placed in a way that makes the system able to detect what bus the fault is located at and if it is the external bus or the main Siemens bus. If the system has located a fault with very small resistance path to a Siemens bus, this bus should be isolated from the others. In addition, the external DC bus should switch power supply to another healthy bus. If the fault however is located to an external bus, the Siemens bus connected to the faulty bus should be disconnected from the other busses in order to reduce the probability of a second ground fault.

Components connected to the external DC bus represent the biggest challenge in the system. This is because small loads of just some tens of kilowatts are connected directly to the DC system. Faults in these components change the potential between phase and ground throughout the entire system. In order to improve the reliability of the system, requirements to components connected to the DC bus should be considered. Ground fault localizing for components considered vulnerable, or RCD for non-essential components. Small loads with a higher probability of faults could also be separated from the DC feed by one common power transformer. This also gives the opportunity to reduce the voltage levels for small loads to 440V giving cheaper components and saving number of inverters (as long as they use constant speed). The increased cost of a separate AC bus could however be more costly than the saved cost of the more expensive 690V engines and inverters. The disadvantages with the solution using power transformers is that it introduce much weight in the transformer and a large rectifier and inverter. A third option is to use current limiting reactors in order to reduce the fault current of a subsequent fault. This solution however should be used in combination with other measures to limit the possibility of a second fault as it is only based on reducing the fault current. Not reducing the probability of a sub-sequent ground fault.

When evaluating what type of grounding system should be used, the operational reliability of the system should be the most important consideration. Because of this, the TN system could be excluded due to its large fault currents at the first ground fault. Since there are several ways to detect and locate faults in an IT system even without de-energizing the bus, the argument for using TT system disappear. The use of IT system is therefore considered the best alternative for this type of vessel.

## 8 Conclusion

Simulations in this thesis show that normal operation of the system is not affected by the first ground fault. The only change is an increase in the voltage stress across the insulation. Simulations also show that it is important to clear the first fault as soon as possible after it is detected in order to avoid a harmful second fault. A second ground fault will harm the system in the same way as a short circuit would.

When a fault with low ground path resistance is detected, an automatic localization system should be used in order to detect where in the system the fault have occurred. A minimum should be that the system is able to locate what bus the fault is connected. If the system have located a fault, it should be able to automatically take action in order to reduce the probability of a second fault occurring. This can be done by isolating the faulty bus. The best solution for ground fault localization, are well established and tested systems.

The rapport conclude that the best-suited grounding system is the IT grounding system. This is because it is important to maintain normal operations even when a fault occurs.



## 9 Bibliography

- [1] T. Årdalsbakke, "DC Diesel electric propulsion and Hybrid power system," Specialisation project Specialization project, IME, NTNU, 2014.
- [2] A. Kristoffersen, "Complex machinery systems," T. Årdalsbakke, Ed., ed, 2015.
- [3] DNV. (2013). *Dynamic positioning Systems*. Available: <https://exchange.dnv.com/publishing/ruleship/2013-07/ts607.pdf>
- [4] M. Valdes, T. Papallo, and B. Premerlani, "Ground Fault Location in Low-Voltage High-Resistance Grounded Systems via the Single-Processor Concept for Circuit Protection," in *Pulp and Paper Industry Technical Conference, 2006. Conference Record of Annual, 2006*, pp. 1-8.
- [5] J. A. Marrero, "Understand ground fault detection and isolation in DC systems," in *Power Engineering Society Summer Meeting, 2000. IEEE, 2000*, pp. 1707-1711 vol. 3.
- [6] Y. Pan, P. M. Silveira, M. Steurer, T. L. Baldwin, and P. F. Ribeiro, "A fault location approach for high-impedance grounded DC shipboard power distribution systems," in *Power and Energy Society General Meeting - Conversion and Delivery of Electrical Energy in the 21st Century, 2008 IEEE, 2008*, pp. 1-6.
- [7] Bender, "The power in electrical safety - Product overview," ed: Bender, 2015.
- [8] Bender, "IRDH575 Series - Digital Ground Fault Monitor," Bender, Ed., ed: Bender, 2011.



## 10 Recommendation for further work

Following tasks can be done in further work:

- Carry out simulations using dynamic components instead of static components in order to control the quality of the results obtained with static components in this report. Simulations using dynamic components are more reliable when simulating second ground-faults. See Appendix F for further information on selection of components for this simulation.
- Conduct lab experiments to control the quality of the results for one phase to ground faults found in this report.
- Further study of ground fault localization techniques for systems with combined AC and DC systems with short cable distances and mesh like buildup.
- Study and develop the ground fault localization method using background noise of the power electronics. (see IEEE report for further information: [6])
- Develop a ground fault localization topology for the external DC bus. More information on the components connected to the external bus is needed for this task.
- Develop a control strategy for locating and handling ground faults in a DC shipboard power system. How accurate do the system need to locate faults? How can the system locate faults accurate enough and how should the system act when a fault is located?
- Test a localization strategy in a lab setup with combined AC and DC system using power electronics and several output terminals.





## Appendices

| Appendix | Description  | Page |
|----------|--|------|
| A        | Data for DC-feed cable, capacitor bank and batteries         | 75   |
| B        | Table for cable data   | 76   |
| C        | Data for components in the model                             | 77   |
| D        | Illustration of simulation model                             | 78   |
| E        | Data and illustration of all subsystems                      | 80   |
| F        | Recommendation for choice of figures for dynamic simulations | 101  |



# Appendix A:

Data for DC-feed cable given on mail from Siemens:

| Type                      | R(20°C) [Ω/km] | L [mH/km] | I <sub>n</sub> [A] | Length [m]                                     | Number of parallel cables |
|---------------------------|----------------|-----------|--------------------|--|---------------------------|
| TXOI 4x95 mm <sup>2</sup> | 0.193          | 0.309     | 2x195              | - 40 m from BUS1/BUS4<br>- 90 m from BUS4/BUS1 | 4                         |

Information on capacitorbanks received on mail from Siemens (written in norwegian):

Kondensatorbankene på en enkel 1500kW drive er på 21mF.

Information on batteries received on mail from Siemens:

| SoC   | OCV (V) single cell | OCV (V) 252 cells |
|-------|---------------------|-------------------|
| 100 % | 4,18                | 1053,4            |
| 95 %  | 4,126955            | 1040,0            |
| 90 %  | 4,063716            | 1024,1            |
| 85 %  | 4,006667            | 1009,7            |
| 80 %  | 3,953868            | 998,4             |
| 75 %  | 3,903386            | 983,7             |
| 70 %  | 3,851101            | 970,5             |
| 65 %  | 3,795224            | 956,4             |
| 60 %  | 3,750318            | 945,1             |
| 55 %  | 3,717109            | 936,7             |
| 50 %  | 3,69098             | 930,1             |
| 45 %  | 3,669695            | 924,8             |
| 40 %  | 3,651558            | 920,2             |
| 35 %  | 3,63376             | 915,7             |
| 30 %  | 3,612777            | 910,4             |
| 25 %  | 3,58782             | 904,1             |
| 20 %  | 3,561866            | 897,5             |
| 15 %  | 3,5212              | 887,3             |
| 10 %  | 3,496484            | 881,1             |
| 5 %   | 3,456959            | 871,2             |
| 0 %   | 3,298403            | 831,2             |

Max. discharging current (continues for the chemical battery) 0,7C = 105  
 Max. discharging current (continues for the electrical equipment) 1,7C = 250A  
 Max. discharging current (short term/ 4 minutes) 5C = 750A  
 Max discharging voltage 806V DC

# Appendix B

Tabell 18

Elektriske kabelparametre, PFSP Cu-leder/Cu-skjerm, PVC-isolert

| 2-leder: Resistans og reaktans som ved treleder. Nullparametre sjeident aktuelt (ikke beregnet) |                                      |                            |                            |                     |                     |  |                              |                        |                        |                               |                         |                         |
|---|--------------------------------------|----------------------------|----------------------------|---------------------|---------------------|--|------------------------------|------------------------|------------------------|-------------------------------|-------------------------|-------------------------|
| Forutsetning ved usymmetrisk feil: Returvei via skjerm.   |                                      |                            |                            |                     |                     |  |                              |                        |                        |                               |                         |                         |
| Relativ dielektrisitetskonstant: 4,0 (ved 20°C) X/R < 0,2 (X og L kan neglisjeres)              |                                      |                            |                            |                     |                     |  |                              |                        |                        |                               |                         |                         |
| 3-leder:  |                                      |                            |                            |                     |                     | 4-leder:   |                              |                        |                        |                               |                         |                         |
| Symmetriske parametre (pr. fase)  |                                      |                            |                            |                     |                     | Symmetriske parametre (pr. fase)                                       |                              |                        |                        |                               |                         |                         |
| Leder-tverrsnitt (mm <sup>2</sup> )   | Skjerm-tverrsnitt (mm <sup>2</sup> ) | Resistans DC 20°C (ohm/km) | Resistans AC 70°C (ohm/km) | Reaktans X (ohm/km) | Induktans L (mH/km) | Drifts-kapasitet (µF/km)   | Null-resistans 20°C (ohm/km) | Null-reaktans (ohm/km) | Null-induktans (mH/km) | Retur-resistans 20°C (ohm/km) | Retur-reaktans (ohm/km) | Retur-induktans (mH/km) |
| 3x1,5   | 1,5                                  | 12,100                     | 14,48                      | 0,108               | 0,35                | 0,23   | 48,40                        | 0,123                  | 0,390                  | 12,10                         | 0,001                   | 0,002                   |
| 3x2,5   | 2,5                                  | 7,410                      | 8,87                       | 0,101               | 0,32                | 0,26   | 29,64                        | 0,120                  | 0,382                  | 7,41                          | 0,001                   | 0,002                   |
| 3x4   | 4                                    | 4,610                      | 5,52                       | 0,100               | 0,32                | 0,26   | 18,44                        | 0,118                  | 0,374                  | 4,61                          | 0,001                   | 0,002                   |
| 3x6   | 6                                    | 3,080                      | 3,69                       | 0,094               | 0,30                | 0,29   | 12,32                        | 0,113                  | 0,360                  | 3,08                          | 0,001                   | 0,002                   |
| 3x10  | 10                                   | 1,830                      | 2,19                       | 0,087               | 0,28                | 0,34   | 7,32                         | 0,108                  | 0,342                  | 1,83                          | 0,001                   | 0,002                   |
| 3x16  | 16                                   | 1,150                      | 1,38                       | 0,082               | 0,26                | 0,39   | 4,60                         | 0,103                  | 0,328                  | 1,15                          | 0,001                   | 0,002                   |
| 3x25  | 16                                   | 0,727                      | 0,870                      | 0,078               | 0,25                | 0,44   | 4,18                         | 0,098                  | 0,311                  | 1,15                          | 0,001                   | 0,002                   |
| 3x35  | 16                                   | 0,524                      | 0,627                      | 0,079               | 0,25                | 0,44   | 3,97                         | 0,097                  | 0,309                  | 1,15                          | 0,001                   | 0,002                   |
| 3x50  | 25                                   | 0,387                      | 0,464                      | 0,079               | 0,25                | 0,44   | 2,57                         | 0,096                  | 0,306                  | 0,727                         | 0,001                   | 0,002                   |
| 3x70  | 35                                   | 0,268                      | 0,321                      | 0,076               | 0,24                | 0,48   | 1,84                         | 0,095                  | 0,302                  | 0,524                         | 0,001                   | 0,002                   |
| 3x95  | 50                                   | 0,193                      | 0,232                      | 0,075               | 0,24                | 0,49   | 1,35                         | 0,094                  | 0,299                  | 0,387                         | 0,001                   | 0,002                   |
| 3x120   | 70                                   | 0,153                      | 0,184                      | 0,074               | 0,23                | 0,52   | 0,96                         | 0,093                  | 0,296                  | 0,268                         | 0,001                   | 0,002                   |
| 3x150   | 70                                   | 0,124                      | 0,150                      | 0,074               | 0,24                | 0,52   | 0,93                         | 0,092                  | 0,294                  | 0,268                         | 0,001                   | 0,002                   |
| 3x185   | 95                                   | 0,099                      | 0,121                      | 0,074               | 0,24                | 0,52   | 0,68                         | 0,091                  | 0,290                  | 0,193                         | 0,001                   | 0,002                   |
| 3x240   | 120                                  | 0,075                      | 0,093                      | 0,072               | 0,23                | 0,55   | 0,53                         | 0,090                  | 0,288                  | 0,153                         | 0,001                   | 0,002                   |
| 3-leder:  |                                      |                            |                            |                     |                     | 4-leder:   |                              |                        |                        |                               |                         |                         |
| *) Beregnet som ved treleder  |                                      |                            |                            |                     |                     | *)   |                              |                        |                        |                               |                         |                         |
| Forutsetning ved usymmetriske feil: Returvei via skjerm og null-leder.                          |                                      |                            |                            |                     |                     | Forutsetning ved usymmetriske feil: Returvei via skjerm og null-leder. |                              |                        |                        |                               |                         |                         |
| Symmetriske parametre (pr. fase)  |                                      |                            |                            |                     |                     | Symmetriske parametre (pr. fase)                                       |                              |                        |                        |                               |                         |                         |
| Leder-tverrsnitt (mm <sup>2</sup> )   | Skjerm-tverrsnitt (mm <sup>2</sup> ) | Resistans DC 20°C (ohm/km) | Resistans AC 70°C (ohm/km) | Reaktans X (ohm/km) | Induktans L (mH/km) | Drifts-kapasitet (µF/km)   | Null-resistans 20°C (ohm/km) | Null-reaktans (ohm/km) | Null-induktans (mH/km) | Retur-resistans 20°C (ohm/km) | Retur-reaktans (ohm/km) | Retur-induktans (mH/km) |
| 4x1,5   | 1,5                                  | 12,100                     | 14,48                      | 0,114               | 0,36                | 0,23   | 30,25                        | 0,19                   | 0,62                   | 6,05                          | 0,025                   | 0,079                   |
| 4x2,5   | 2,5                                  | 7,410                      | 8,87                       | 0,111               | 0,35                | 0,26   | 18,53                        | 0,19                   | 0,60                   | 3,71                          | 0,024                   | 0,076                   |
| 4x4   | 4                                    | 4,610                      | 5,52                       | 0,107               | 0,34                | 0,26   | 11,53                        | 0,18                   | 0,59                   | 2,31                          | 0,023                   | 0,074                   |
| 4x6   | 6                                    | 3,080                      | 3,69                       | 0,101               | 0,32                | 0,29   | 7,70                         | 0,18                   | 0,56                   | 1,54                          | 0,022                   | 0,070                   |
| 4x10  | 10                                   | 1,830                      | 2,19                       | 0,096               | 0,30                | 0,34   | 4,58                         | 0,17                   | 0,54                   | 0,92                          | 0,022                   | 0,070                   |
| 4x16  | 16                                   | 1,150                      | 1,38                       | 0,092               | 0,29                | 0,39   | 2,88                         | 0,18                   | 0,57                   | 0,58                          | 0,027                   | 0,086                   |
| 4x25  | 16                                   | 0,727                      | 0,870                      | 0,089               | 0,28                | 0,44   | 2,06                         | 0,19                   | 0,60                   | 0,45                          | 0,031                   | 0,099                   |
| 4x35  | 16                                   | 0,524                      | 0,627                      | 0,087               | 0,28                | 0,44   | 1,60                         | 0,21                   | 0,66                   | 0,36                          | 0,038                   | 0,122                   |
| 4x50  | 25                                   | 0,387                      | 0,464                      | 0,086               | 0,27                | 0,44   | 1,14                         | 0,19                   | 0,62                   | 0,25                          | 0,035                   | 0,110                   |

# Appendix C

|                      |                                   |                            |                                |   |  |
|----------------------|-----------------------------------|----------------------------|--------------------------------|---|--|
| <b>Component:</b>    | Voltage (phase-to-phase RMS): [V] | Phase shift: [deg]         | Frequency: [Hz]                | Resistance between N and Ground: [Mohm]   |  |
| Generator            | 690                               |                            | 0                              | 60  | 1000   |
| <b>Component:</b>    | Forward voltage: [V]              | On resistance: [Ohm]       | Off conductance: [1/Ohm]       | Notice:                                   |  |
| Rectifier            | 0,8                               |                            | 0,001                          | 1,00E-06 No charge dynamics               |  |
| <b>Component:</b>    | Nominal Voltage, Vnom: [V]        | Ampere-hour rating: [hr*A] | Initial charge: [hr*A]         | Voltage V1 (<Vnom) when charge is Q1: [V] | Charge when Q1 when no-load volts are V1: [hr*A]           |
| Battery              | 1053                              | 150                        | 75                             | 930                                       | 75   |
| <b>Component:</b>    | Parametization:                   | Component structure:       | Rated voltage: [V]             | Rated electrical frequency: [Hz]          | Real power: [kw]   |
| Thruster 1:          | Specify by rated power            | Series RL                  | 690                            | 690                                       | 60   |
| Thruster 2:          | Specify by rated power            | Series RL                  | 690                            | 690                                       | 60   |
| Engine 3:            | Specify by rated power            | Series RL                  | 690                            | 690                                       | 60   |
| Engine 4:            | Specify by rated power            | Series RL                  | 690                            | 690                                       | 60   |
| Engine 5:            | Specify by rated power            | Series RL                  | 690                            | 690                                       | 60   |
| Engine 6:            | Specify by rated power            | Series RL                  | 690                            | 690                                       | 60   |
| <b>Component:</b>    | Capacitance: [mF]                 | Series Resistance: [Ohm]   | Parallell conductance: [1/Ohm] |   |  |
| Capacitor bank C     | 21                                | 1,00E-06                   | 0                              |   |  |
| Capacitor bank C1    | 42                                | 1,00E-06                   | 0                              |   |  |
| Capacitor bank C2    | 42                                | 1,00E-06                   | 0                              |   |  |
| Capacitor bank C3    | 21                                | 1,00E-06                   | 0                              |   |  |
| Capacitor bank C4    | 21                                | 1,00E-06                   | 0                              |   |  |
| Capacitor bank C5    | 21                                | 1,00E-06                   | 0                              |   |  |
| Capacitor bank C6    | 21                                | 1,00E-06                   | 0                              |   |  |
| <b>Component:</b>    | Switching device:                 | On-state resistance: [Ohm] | Off-state conductance: [S]     | Threshold voltage, Vth: [V]               | Notice:  |
| Converter Th1        | Ideal Semiconductor Switch        | 1,00E-03                   | 1,00E-06                       |   | 0,5 Standard Protection diode with no dynamics. No snubber |
| Converter Th2        | Ideal Semiconductor Switch        | 1,00E-03                   | 1,00E-06                       |   | 0,5 Standard Protection diode with no dynamics. No snubber |
| Converter 3          | Ideal Semiconductor Switch        | 1,00E-03                   | 1,00E-06                       |   | 0,5 Standard Protection diode with no dynamics. No snubber |
| Converter 4          | Ideal Semiconductor Switch        | 1,00E-03                   | 1,00E-06                       |   | 0,5 Standard Protection diode with no dynamics. No snubber |
| Converter 5          | Ideal Semiconductor Switch        | 1,00E-03                   | 1,00E-06                       |   | 0,5 Standard Protection diode with no dynamics. No snubber |
| Converter 6          | Ideal Semiconductor Switch        | 1,00E-03                   | 1,00E-06                       |   | 0,5 Standard Protection diode with no dynamics. No snubber |
| <b>Component:</b>    | Nominal AC frequency: [Hz]        | Pulses per AC cycle        | Clock cycles per pulse         |   |  |
| Converter controls 1 | 60                                | 30                         | 30                             |   |  |
| Converter controls 2 | 60                                | 30                         | 30                             |   |  |
| Converter controls 3 | 60                                | 30                         | 30                             |   |  |
| Converter controls 4 | 60                                | 30                         | 30                             |   |  |
| Converter controls 5 | 60                                | 30                         | 30                             |   |  |
| Converter controls 6 | 60                                | 30                         | 30                             |   |  |
| <b>Component:</b>    | Cable length: [m]                 | Resistance: [Ohm/km]       | Inductance: [mH/km]            | Mutual Inductance: [mH/km]                | Line-line capacitance: [uF/km]                             |
| Cable 1              | 50                                | 0,02325                    | 0,0575                         | 0,0575                                    | 0,7  |
| Cable 2              | 50                                | 0,02325                    | 0,0575                         | 0,0575                                    | 0,7  |
| Cable 3              | 30                                | 0,093                      | 0,23                           | 0,23                                      | 0,55   |
| Cable 4              | 50                                | 0,075                      | 0,12                           | 0,12                                      | 0,6  |
| Cable 5              | 40                                | 0,321                      | 0,24                           | 0,24                                      | 0,48   |
| Cable 6              | 30                                | 8,87                       | 0,32                           | 0,32                                      | 0,26   |
| <b>Component:</b>    | Cable length: [m]                 | Resistance: [Ohm]          | Inductance: [mH]               | Parallell conductance: [Ohm]              | Number of segments:  |
| Inductor DC feed +   | 50                                | 0                          | 0,01545                        | 1,00E-09                                  | 1  |
| Inductor DC feed -   | 50                                | 0                          | 0,01545                        | 1,00E-09                                  | 1  |
| Resistor DC feed +   | 50                                | 0,00965                    | 0                              | 0   | 1  |
| Resistor DC feed -   | 50                                | 0,00965                    | 0                              | 0   | 1  |

# Appendix D

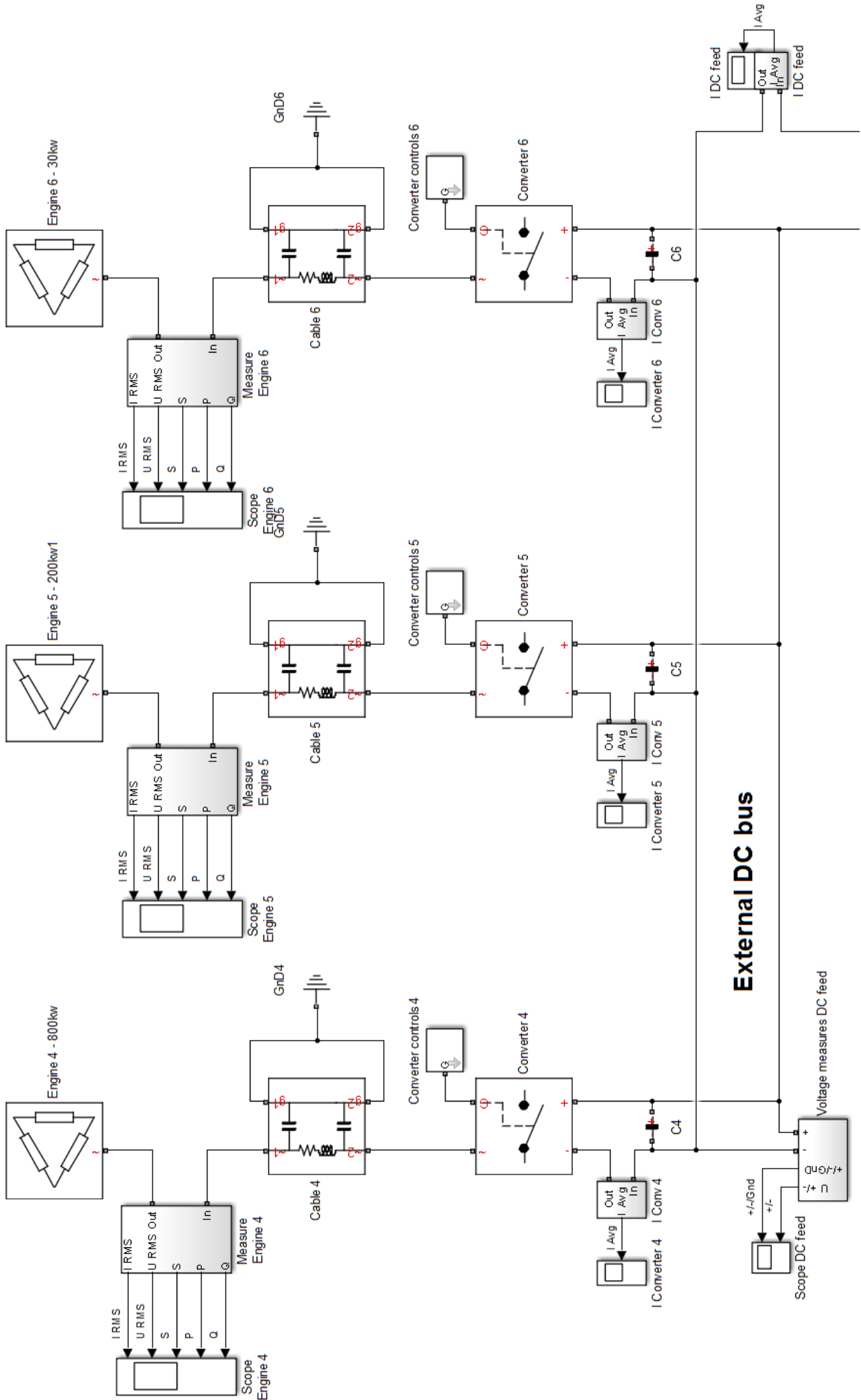

# Appendix D

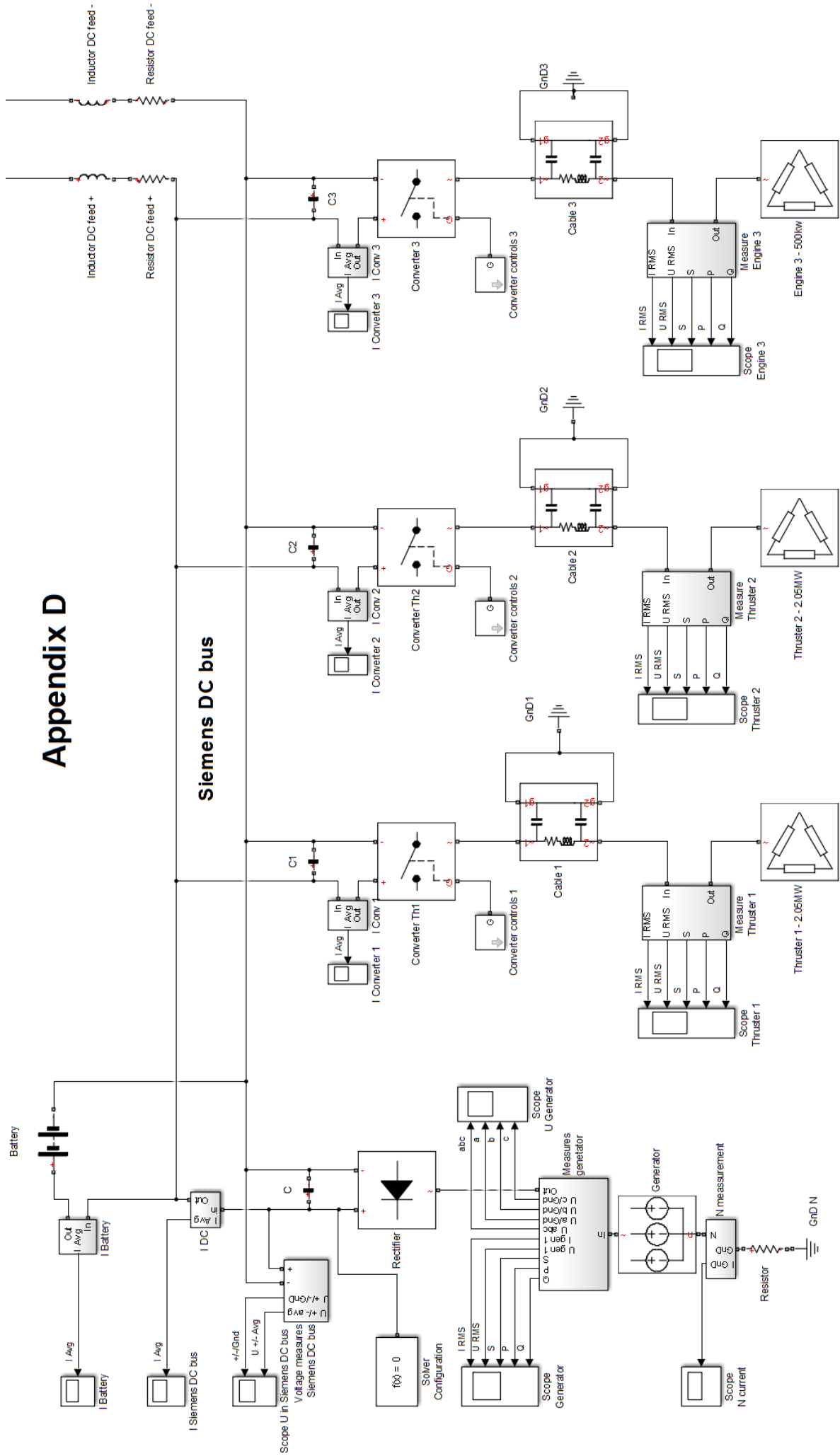

# Appendix E - AC Fault generator subsystem

## ACfaultgenerator

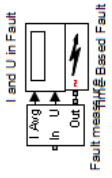

torfina

15-May-2015 10:30:58

### Table of Contents

- [Model - ACfaultgenerator](#)
- [System - ACfaultgenerator](#)
- [System - ACfaultgenerator/Fault\\_measure Appendix](#)

### List of Tables

- [Time-Based Fault Block Properties](#)
- [Current Sensor Block Properties](#)
- [Line Voltage Sensor Block Properties](#)
- [Mean Block Properties](#)
- [Mux Block Properties](#)
- [Output Block Properties](#)
- [PMIOPort Block Properties](#)
- [PS-Simulink Converter Block Properties](#)
- [Block Type Count](#)

## Model - ACfaultgenerator

### Full Model Hierarchy

- [ACfaultgenerator](#)
  - [Fault\\_measure](#)

| Simulation Parameter | Value |
|----------------------|-------|
| Solver               | ode45 |
| RelTol               | 1e-3  |
| Refine               | 1     |
| MaxOrder             | 5     |
| ZeroCross            | on    |

[/more info/](#)

## System - ACfaultgenerator





Table 5. Mux Block Properties

| Name | Inputs | Display Option |
|------|--------|----------------|
| Mux  | 2      | bar            |

Table 6. Outport Block Properties

| Name  | Port | Icon Display | Lock Scale | Var Size Sig | Signal Type | Sampling Mode | Source Of Initial Output Value | Output When Disabled | Used By Blk      |
|-------|------|--------------|------------|--------------|-------------|---------------|--------------------------------|----------------------|------------------|
| I Avg | 1    | Port number  | off        | Inherit      | auto        | auto          | Dialog                         | held                 | I and U in Fault |
| U     | 2    | Port number  | off        | Inherit      | auto        | auto          | Dialog                         | held                 | I and U in Fault |

Table 7. PMIOPort Block Properties

| Name | Port | Side  |
|------|------|-------|
| In   | 2    | Left  |
| Out  | 1    | Right |

Table 8. PS-Simulink Converter Block Properties

| Name                   | Physical Domain       | Sub Class Name | Left Port Type | Right Port Type | Pseudo Periodic | Unit | Affine Conversion |
|------------------------|-----------------------|----------------|----------------|-----------------|-----------------|------|-------------------|
| PS-Simulink Converter  | network_engine_domain | ps_output      | input          | output          | off             | 1    | off               |
| PS-Simulink Converter2 | network_engine_domain | ps_output      | input          | output          | off             | 1    | off               |

## Appendix

Table 9. Block Type Count

| BlockType                 | Count | Block Names  |
|---------------------------|-------|--|
| PS-Simulink Converter (m) | 2     | <a href="#">PS-Simulink Converter</a> , <a href="#">PS-Simulink Converter2</a> |
| PMIOPort                  | 2     | <a href="#">In</a> , <a href="#">Out</a>                                       |
| Outport                   | 2     | <a href="#">I Avg</a> , <a href="#">U</a>                                      |
| Time-Based Fault (m)      | 1     | <a href="#">Time-Based Fault</a>   |
| SubSystem                 | 1     | <a href="#">Fault measure</a>  |
| Scope                     | 1     | I and U in Fault   |
| Mux                       | 1     | <a href="#">Mux</a>  |
| Mean (m)                  | 1     | <a href="#">Avg</a>  |
| Line Voltage Sensor (m)   | 1     | <a href="#">Line Voltage Sensor</a>  |
| Current Sensor (m)        | 1     | <a href="#">Current Sensor</a>   |

# Appendix E - AC loads measurements subsystems

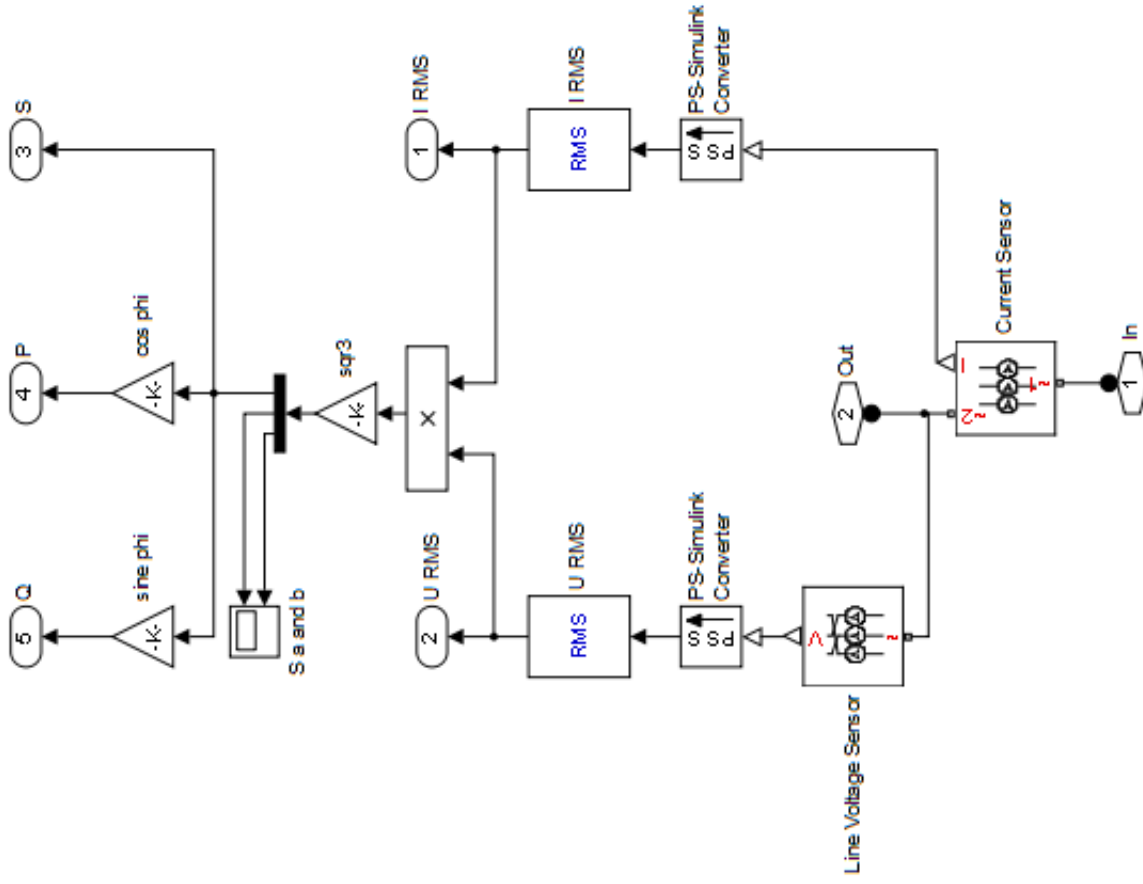

Table 1. Current Sensor Block Properties

| Name           | Component Path         | Component Variants                              | Component Variant Names                                 | Class Name       | Schema Version |
|----------------|------------------------|---|---|------------------|----------------|
| Current Sensor | pe.sensors.current.abc | pe.sensors.current.abc, no.sensors.current.Yabc | Composite three-phase ports, Expanded three-phase ports | Simscape_variant | 1              |

**Table 2. Demux Block Properties**

| Name  | Outputs | Display Option | Bus Selection Mode |
|-------|---------|----------------|--------------------|
| Demux | 3       | bar            | off                |

**Table 3. Gain Block Properties**

| Name     | Gain    | Multiplication     | Param Data Type Str                | Out Data Type Str                  | Lock Scale | Rnd Meth | Saturate On Integer Overflow |
|----------|---------|--------------------|------------------------------------|------------------------------------|------------|----------|------------------------------|
| cos phi  | 0.85    | Element-wise(K.*u) | Inherit: Inherit via internal rule | Inherit: Inherit via internal rule | off        | Floor    | off                          |
| sine phi | 0.53    | Element-wise(K.*u) | Inherit: Inherit via internal rule | Inherit: Inherit via internal rule | off        | Floor    | off                          |
| sqr3     | sqrt(3) | Element-wise(K.*u) | Inherit: Inherit via internal rule | Inherit: Inherit via internal rule | off        | Floor    | off                          |

**Table 4. Line Voltage Sensor Block Properties**

| Name                | Component Path              | Component Variants  | Component Variant Names                                 | Class Name       | Schema Version |
|---------------------|-----------------------------|---|---|------------------|----------------|
| Line Voltage Sensor | pe.sensors.voltage.line.abc | pe.sensors.voltage.line.abc<br>pe.sensors.voltage.line.Xabc | Composite three-phase ports, Expanded three-phase ports | Simscape variant | 1              |

**Table 5. Outport Block Properties**

| Name  | Port | Icon Display | Lock Scale | Var Size Sig | Signal Type | Sampling Mode | Source Of Initial Output Value | Output When Disabled | Used By Blk                                 |
|-------|------|--------------|------------|--------------|-------------|---------------|--------------------------------|----------------------|---|
| I RMS | 1    | Port number  | off        | Inherit      | auto        | auto          | Dialog                         | held                 | Scope Thruster 1 , <a href="#">Product2</a> |
| P     | 4    | Port number  | off        | Inherit      | auto        | auto          | Dialog                         | held                 | Scope Thruster 1                            |
| Q     | 5    | Port number  | off        | Inherit      | auto        | auto          | Dialog                         | held                 | Scope Thruster 1                            |

|       |   |             |     |         |      |      |        |      |  |
|-------|---|-------------|-----|---------|------|------|--------|------|--|
| S     | 3 | number      | off | Inherit | auto | auto | Dialog | held | scope 1 mustel 1 , <a href="#">sine piL</a> ,<br><a href="#">cos phi</a> |
| U RMS | 2 | Port number | off | Inherit | auto | auto | Dialog | held | Scope Thruster 1 , <a href="#">Product2</a>                              |

**Table 6. PMIOPort Block Properties**

| Name | Port | Side |
|------|------|------|
| In   | 1    | Left |
| Out  | 2    | Left |

**Table 7. PS-Simulink Converter Block Properties**

| Name                  | Physical Domain       | Sub Class Name | Left Port Type | Right Port Type | Pseudo Periodic | Unit | Affine Conversion |
|-----------------------|-----------------------|----------------|----------------|-----------------|-----------------|------|-------------------|
| PS-Simulink Converter | network_engine_domain | ps_output      | input          | output          | off             | 1    | off               |
| PS-Simulink Converter | network_engine_domain | ps_output      | input          | output          | off             | 1    | off               |

**Table 8. Product Block Properties**

| Name     | Inputs | Multiplication  | Collapse Mode  | Collapse Dim | Input Same DT | Out Data Type Str            | Lock Scale | Rnd Meth | Saturate On Integer Overflow |
|----------|--------|-----------------|----------------|--------------|---------------|------------------------------|------------|----------|------------------------------|
| Product2 | 2      | Element-wise(*) | All dimensions | 1            | on            | Inherit: Same as first input | off        | Floor    | on                           |

**Table 9. RMS Block Properties**

| Name  | True RMS | Freq | RMSInit | Ts |
|-------|----------|------|---------|----|
| I RMS | on       | 60   | 120     | 0  |
| U RMS | on       | 60   | 120     | 0  |

## Appendix

**Table 10. Block Type Count**

# Appendix E - Converter control subsystems

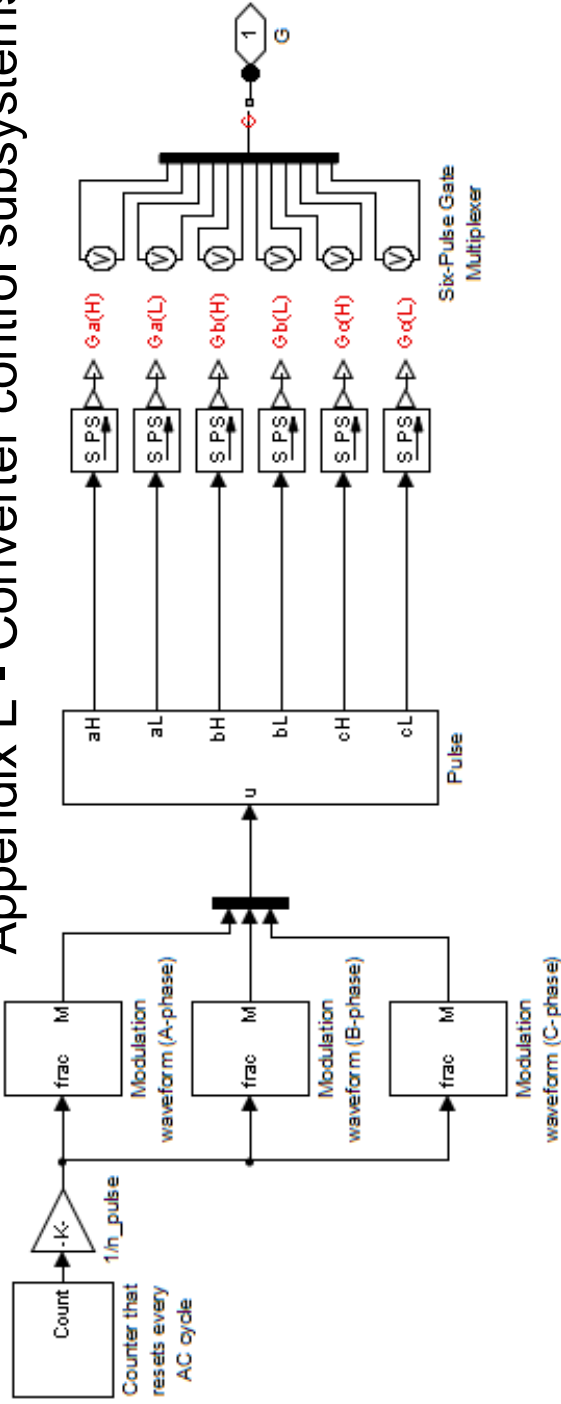

Table 1. Gain Block Properties

| Name      | Gain                  | Multiplication     | Param Data Type Str    | Out Data Type Str      | Lock Scale | Rnd Meth | Saturate On Integer Overflow |
|-----------|-----------------------|--------------------|------------------------|------------------------|------------|----------|------------------------------|
| 1/n_pulse | 1/pulses_per_ac_cycle | Element-wise(K.*u) | Inherit: Same as input | Inherit: Same as input | off        | Floor    | on                           |

Table 2. Mux Block Properties

| Name | Inputs | Display Option |
|------|--------|----------------|
| Mux  | 3      | bar            |

Table 3. PMIOPort Block Properties

| Name | Port | Side |
|------|------|------|
| G    | 1    | Left |

Table 4. Simulink-PS Converter Block Properties

|  | Sub | Left | Right | Pseudo | Noise | Affine | Input | Simscape | Input Filter | Udot |
|--|-----|------|-------|--------|-------|--------|-------|----------|--------------|------|
|  |     |      |       |        |       |        |       |          |              |      |

| Name | Physical Domain       | Class Name | Port Type | Port Type | Periodic | Distribution | Unit Conversion | Filtering | Filter Order | Time Constant | User Provided |
|------|-----------------------|------------|-----------|-----------|----------|--------------|-----------------|-----------|--------------|---------------|---------------|
| S1PS | network_engine_domain | ps_input   | input     | output    | off      | none         | 1               | off       | 1            | .001          | 1             |
| S2PS | network_engine_domain | ps_input   | input     | output    | off      | none         | 1               | off       | 1            | .001          | □             |
| S3PS | network_engine_domain | ps_input   | input     | output    | off      | none         | 1               | off       | 1            | .001          | □             |
| S4PS | network_engine_domain | ps_input   | input     | output    | off      | none         | 1               | off       | 1            | .001          | □             |
| S5PS | network_engine_domain | ps_input   | input     | output    | off      | none         | 1               | off       | 1            | .001          | □             |
| S6PS | network_engine_domain | ps_input   | input     | output    | off      | none         | 1               | off       | 1            | .001          | □             |

**Table 5. Six-Pulse Gate Multiplexer Block Properties**

| Name                       | Component Path                                  | Component Variants                              | Component Variant Names                           | Class Name       | Schema Version | R unit |
|----------------------------|---|---|---|------------------|----------------|--------|
| Six-Pulse Gate Multiplexer | pe.semiconductors.six_pulse_gate_multiplexer.ps | pe.semiconductors.six_pulse_gate_multiplexer.ps | pe.semiconductors.six_pulse_gate_multiplexer.elec | Simscape variant | 1              | 0 Ohm  |

## Appendix

**Table 6. Block Type Count**

| BlockType                      | Count | Block Names   |
|--------------------------------|-------|---|
| SubSystem                      | 6     | <a href="#">Converter controls_1</a> , Counter that resets every AC cycle, Modulation waveform (A-phase), Modulation waveform (B-phase), Modulation waveform (C-phase), Pulse |
| Simulink-PS Converter (m)      | 6     | <a href="#">S1PS</a> , <a href="#">S2PS</a> , <a href="#">S3PS</a> , <a href="#">S4PS</a> , <a href="#">S5PS</a> , <a href="#">S6PS</a>                                       |
| Six-Pulse Gate Multiplexer (m) | 1     | <a href="#">Six-Pulse Gate Multiplexer</a>  |

|          |   |                           |
|----------|---|---------------------------|
| PMIOPort | 1 | <a href="#">G</a>         |
| Mux      | 1 | <a href="#">Mux</a>       |
| Gain     | 1 | <a href="#">1/n_pulse</a> |

**Table 7. Model Variables**

| Variable Name       | Parent Blocks             | Calling string        | Value |
|---------------------|---------------------------|-----------------------|-------|
| pulses_per_ac_cycle | <a href="#">1/n_pulse</a> | 1/pulses_per_ac_cycle | 30    |



# Appendix E - DC Current measurement subsystems

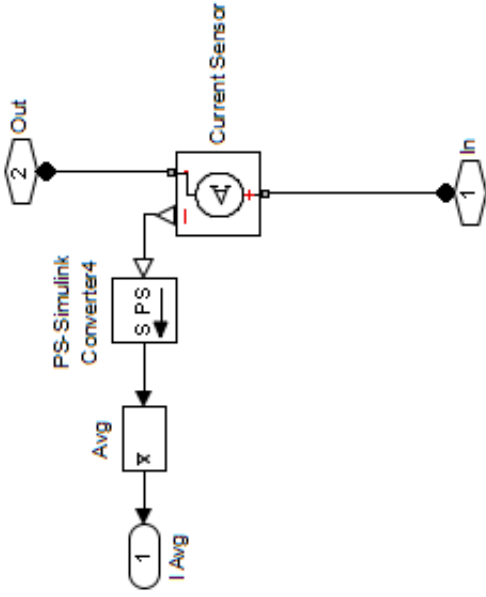

Table 1. Current Sensor Block Properties

| Name           | Component Path                        | Component Variants                    | Component Variant Names | Class Name | Schema Version |
|----------------|---------------------------------------|---------------------------------------|-------------------------|------------|----------------|
| Current Sensor | foundation.electrical.sensors.current | foundation.electrical.sensors.current | current                 | current    | 1              |

Table 2. Mean Block Properties

| Name | Freq | Vinit | Ts |
|------|------|-------|----|
| Avg  | 60   | 0     | 0  |

Table 3. Outport Block Properties

| Name    | Port Display    | Lock Scale | Var Size Sig | Signal Type | Sampling Mode | Source Of Initial Output Value | Output When Disabled | Used By Blk |
|---------|-----------------|------------|--------------|-------------|---------------|--------------------------------|----------------------|-------------|
| I Avg 1 | Port number off | Inherit    | auto         | auto        | Dialog        | held                           | I Converter 1        |             |

Table 4. PMIOPort Block Properties

| Name | Component Path | Component Variants | Component Variant Names | Class Name | Schema Version |
|------|----------------|--------------------|-------------------------|------------|----------------|
|      |                |                    |                         |            |                |

| Name | Port | Side |
|------|------|------|
| In   | 1    | Left |
| Out  | 2    | Left |

Table 5. PS-Simulink Converter Block Properties

| Name                   | Physical Domain       | Sub Class Name | Left Port Type | Right Port Type | Pseudo Periodic | Unit | Affine Conversion |
|------------------------|-----------------------|----------------|----------------|-----------------|-----------------|------|-------------------|
| PS-Simulink Converter4 | network_engine_domain | ps_output      | input          | output          | off             | 1    | off               |

## Appendix

Table 6. Block Type Count

| BlockType                 | Count | Block Names                              |
|---------------------------|-------|--|
| PMIOPort                  | 2     | <a href="#">In</a> , <a href="#">Out</a> |
| SubSystem                 | 1     | <a href="#">IConv1</a>                   |
| PS-Simulink Converter (m) | 1     | <a href="#">PS-Simulink Converter4</a>   |
| Output                    | 1     | <a href="#">IAvg</a>                     |
| Mean (m)                  | 1     | <a href="#">Avg</a>                      |
| Current Sensor (m)        | 1     | <a href="#">Current Sensor</a>           |

# DCfaultgenerator

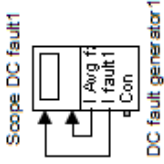

torfina

15-May-2015 10:56:31

## Table of Contents

[Model - DCfaultgenerator](#)  
[System - DCfaultgenerator](#)  
[System - DCfaultgenerator/DC fault\\_generator1](#)  
[Appendix](#)

## List of Tables

1. [Current Sensor Block Properties](#)
2. [Electrical Reference Block Properties](#)
3. [Mean Block Properties](#)
4. [Output Block Properties](#)
5. [PMIOPort Block Properties](#)
6. [PS-Simulink Converter Block Properties](#)
7. [Resistor Block Properties](#)
8. [Simulink-PS Converter Block Properties](#)
9. [Single-Phase Switch Block Properties](#)
10. [Step Block Properties](#)
11. [Block Type Count](#)

## Model - DCfaultgenerator

### Full Model Hierarchy

1. [DCfaultgenerator](#)

1. [DC\\_fault\\_generator1](#)

| Simulation Parameter | Value |
|----------------------|-------|
| Solver               | ode45 |
| RelTol               | 1e-3  |
| Refine               | 1     |
| MaxOrder             | 5     |
| ZeroCross            | on    |

[\[more info\]](#)

### System - DCfaultgenerator

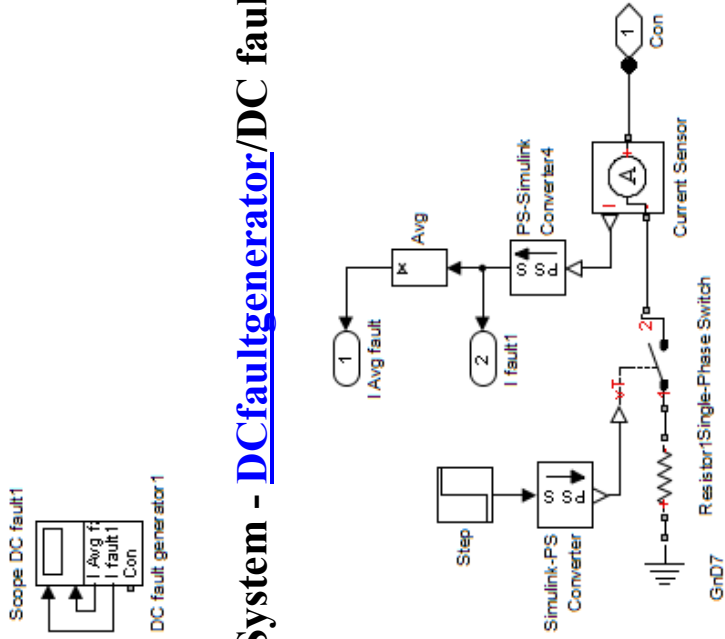

### System - [DCfaultgenerator/DC\\_fault\\_generator1](#)

Table 1. Current Sensor Block Properties

| Name           | Component Path                        | Component Variants                    | Component Variant Names | Class Name | Schema Version |
|----------------|---------------------------------------|---------------------------------------|-------------------------|------------|----------------|
| Current Sensor | foundation.electrical.sensors.current | foundation.electrical.sensors.current | current                 | current    | 1              |

**Table 2. Electrical Reference Block Properties**

| Name | Component Path                           | Component Variants                       | Component Variant Names | Class Name | Schema Version |
|------|--|--|-------------------------|------------|----------------|
| GnD7 | foundation.electrical.elements.reference | foundation.electrical.elements.reference | reference               | reference  | 1              |

**Table 3. Mean Block Properties**

| Name | Freq | Vinit | Ts |
|------|------|-------|----|
| Avg  | 60   | 0     | 0  |

**Table 4. Outport Block Properties**

| Name         | Port | Icon Display | Lock Scale | Var Size Sig | Signal Type | Sampling Mode | Source Of Initial Output Value | Output When Disabled | Used By Blk                 |
|--------------|------|--------------|------------|--------------|-------------|---------------|--------------------------------|----------------------|-----------------------------|
| I Avg fault1 | 1    | Port number  | off        | Inherit      | auto        | auto          | Dialog                         | held                 | Scope DC fault1             |
| I fault1     | 2    | Port number  | off        | Inherit      | auto        | auto          | Dialog                         | held                 | Scope DC fault1, integrator |

**Table 5. PMIOPort Block Properties**

| Name | Port | Side  |
|------|------|-------|
| Con  | 1    | Right |

**Table 6. PS-Simulink Converter Block Properties**

| Name                   | Physical Domain       | Sub Class Name | Left Port Type | Right Port Type | Pseudo Periodic | Unit | Affine Conversion |
|------------------------|-----------------------|----------------|----------------|-----------------|-----------------|------|-------------------|
| PS-Simulink Converter4 | network_engine_domain | ps_output      | input          | output          | off             | 1    | off               |

**Table 7. Resistor Block Properties**

| Name      | Component Path                          | Component Variants                      | Component Variant Names | Class Name | Schema Version | R unit    | I specify | I priority | I unit | V specify | V priority | V unit |
|-----------|---|---|-------------------------|------------|----------------|-----------|-----------|------------|--------|-----------|------------|--------|
| Resistor1 | foundation.electrical.elements.resistor | foundation.electrical.elements.resistor | resistor                | resistor   | 1              | 0.001 Ohm | off       | High       | 0A     | off       | High       | 0 V    |

**Table 8. Simulink-PS Converter Block Properties**

| Name                  | Physical Domain       | Sub Class Name | Left Port Type | Right Port Type | Pseudo Periodic | Noise Distribution | Unit | Affine Conversion | Input Filtering | Simscape Filter Order | Input Filter Time Constant | Udot User Provided |
|-----------------------|-----------------------|----------------|----------------|-----------------|-----------------|--------------------|------|-------------------|-----------------|-----------------------|----------------------------|--------------------|
| Simulink-PS Converter | network_engine_domain | ps_input       | input          | output          | off             | none               | 1    | off               | off             | 1                     | 0.001                      | 1                  |

**Table 9. Single-Phase Switch Block Properties**

| Name                | Component Path                    | Component Variants   | Component Variant Names                     | Class Name       | Schema Version | R closed | R closed unit | G open | G open unit | Threshold | Threshold unit |
|---------------------|-----------------------------------|--|---|------------------|----------------|----------|---------------|--------|-------------|-----------|----------------|
| Single-Phase Switch | pe.switches.fundamental.switch.ps | pe.switches.fundamental.switch.ps<br>pe.switches.fundamental.switch.elec | PS control port,<br>Electrical control port | Simscape variant | 1              | 0.001    | Ohm           | 1e-15  | 1/Ohm       | 0         | V              |

**Table 10. Step Block Properties**

| Name | Time | Before | After | Sample Time | Zero Cross |
|------|------|--------|-------|-------------|------------|
| Step | 0.5  | 0      | 1     | 0           | on         |

## Appendix

**Table 11. Block Type Count**

| BlockType                 | Count | Block Names                            |
|---------------------------|-------|--|
| Output                    | 2     | <a href="#">IAvg fault, I_fault1</a>   |
| SubSystem                 | 1     | <a href="#">DC fault_generator1</a>    |
| Step                      | 1     | <a href="#">Step</a>                   |
| Single-Phase Switch (m)   | 1     | <a href="#">Single-Phase Switch</a>    |
| Simulink-PS Converter (m) | 1     | <a href="#">Simulink-PS Converter</a>  |
| Scope                     | 1     | Scope DC fault1                        |
| Resistor (m)              | 1     | <a href="#">Resistor1</a>              |
| PS-Simulink Converter (m) | 1     | <a href="#">PS-Simulink Converter4</a> |
| PMIOPort                  | 1     | <a href="#">Con</a>                    |
| Mean (m)                  | 1     | <a href="#">Avg</a>                    |
| Electrical Reference (m)  | 1     | <a href="#">GnD7</a>                   |
| Current Sensor (m)        | 1     | <a href="#">Current Sensor</a>         |



**Table 2. Demux Block Properties**

| Name  | Outputs | Display Option | Bus Selection Mode |
|-------|---------|----------------|--------------------|
| Demux | 3       | bar            | off                |

**Table 3. Electrical Reference Block Properties**

| Name | Component Path                           | Component Variants                       | Component Variant Names | Class Name | Schema Version |
|------|--|--|-------------------------|------------|----------------|
| GnD1 | foundation.electrical.elements.reference | foundation.electrical.elements.reference | reference               | reference  | 1              |
| GnD2 | foundation.electrical.elements.reference | foundation.electrical.elements.reference | reference               | reference  | 1              |
| GnD3 | foundation.electrical.elements.reference | foundation.electrical.elements.reference | reference               | reference  | 1              |

**Table 4. Gain Block Properties**

| Name     | Gain    | Multiplication     | Param Data Type Str                | Out Data Type Str                  | Lock Scale | Rnd Meth | Saturate On Integer Overflow |
|----------|---------|--------------------|------------------------------------|------------------------------------|------------|----------|------------------------------|
| cos phi  | 0.85    | Element-wise(K.*u) | Inherit: Inherit via internal rule | Inherit: Inherit via internal rule | off        | Floor    | off                          |
| sine phi | 0.53    | Element-wise(K.*u) | Inherit: Inherit via internal rule | Inherit: Inherit via internal rule | off        | Floor    | off                          |
| sqr3     | sqrt(3) | Element-wise(K.*u) | Inherit: Inherit via internal rule | Inherit: Inherit via internal rule | off        | Floor    | off                          |

**Table 5. Line Voltage Sensor Block Properties**

| Name                | Component Path              | Component Variants   | Component Variant Names                                 | Class Name       | Schema Version |
|---------------------|-----------------------------|--|---|------------------|----------------|
| Line Voltage Sensor | pe.sensors.voltage.line.abc | pe.sensors.voltage.line.abc,<br>pe.sensors.voltage.line.Xabc | Composite three-phase ports, Expanded three-phase ports | Simscape variant | 1              |

**Table 6. Output Block Properties**

| Name  | Port | Icon Display | Lock Scale | Var Size Sig | Signal Type | Sampling Mode | Source Of Initial Output Value | Output When Disabled | Used By Blk |
|-------|------|--------------|------------|--------------|-------------|---------------|--------------------------------|----------------------|-------------|
| I gen |      | Port         |            |              |             |               |                                |                      |             |



|         |   |             |     |         |      |      |        |      |   |
|---------|---|-------------|-----|---------|------|------|--------|------|---|
| 1       | 5 | number      | off | Inherit | auto | auto | Dialog | held | Scope Generator, <a href="#">Product2</a>                           |
| P       | 2 | Port number | off | Inherit | auto | auto | Dialog | held | Scope Generator   |
| Q       | 1 | Port number | off | Inherit | auto | auto | Dialog | held | Scope Generator   |
| S       | 3 | Port number | off | Inherit | auto | auto | Dialog | held | Scope Generator, <a href="#">sine_phi</a> , <a href="#">cos_phi</a> |
| U a/Gnd | 7 | Port number | off | Inherit | auto | auto | Dialog | held | Scope U Generator   |
| U abc   | 6 | Port number | off | Inherit | auto | auto | Dialog | held | Scope U Generator, Product, Product1, Product, Product              |
| U b/Gnd | 8 | Port number | off | Inherit | auto | auto | Dialog | held | Scope U Generator   |
| U c/Gnd | 9 | Port number | off | Inherit | auto | auto | Dialog | held | Scope U Generator   |
| U gen 1 | 4 | Port number | off | Inherit | auto | auto | Dialog | held | Scope Generator, <a href="#">Product2</a>                           |

**Table 7. PMIOPort Block Properties**

| Name | Port | Side  |
|------|------|-------|
| In   | 2    | Left  |
| Out  | 1    | Right |

**Table 8. PS-Simulink Converter Block Properties**

| Name                   | Physical Domain       | Sub Class Name | Left Port Type | Right Port Type | Pseudo Periodic | Unit | Affine Conversion |
|------------------------|-----------------------|----------------|----------------|-----------------|-----------------|------|-------------------|
| PS-Simulink Converter  | network_engine_domain | ps_output      | input          | output          | off             | 1    | off               |
| PS-Simulink Converter1 | network_engine_domain | ps_output      | input          | output          | off             | 1    | off               |
| PS-Simulink Converter2 | network_engine_domain | ps_output      | input          | output          | off             | 1    | off               |
| PS-Simulink Converter3 | network_engine_domain | ps_output      | input          | output          | off             | 1    | off               |

|                        |                       |           |       |        |   |     |
|------------------------|-----------------------|-----------|-------|--------|---|-----|
| PS-Simulink Converter4 | network_engine_domain | ps_output | input | output | 1 | off |
|------------------------|-----------------------|-----------|-------|--------|---|-----|

**Table 9. Phase Splitter Block Properties**

| Name           | Component Path                    | Component Variants                | Component Variant Names                              | Class Name | Schema Version |
|----------------|-----------------------------------|-----------------------------------|--|------------|----------------|
| Phase Splitter | pe.connections.phase_splitter.abc | pe.connections.phase_splitter.abc | Three-phase bus connection to individual connections | abc        | 1              |

**Table 10. Product Block Properties**

| Name     | Inputs | Multiplication  | Collapse Mode  | Collapse Dim | Input Same DT | Out Data Type Str            | Lock Scale | Rnd Meth | Saturate On Integer Overflow |
|----------|--------|-----------------|----------------|--------------|---------------|------------------------------|------------|----------|------------------------------|
| Product2 | 2      | Element-wise(*) | All dimensions | 1            | on            | Inherit: Same as first input | off        | Floor    | on                           |

**Table 11. RMS Block Properties**

| Name  | True RMS | Freq | RMSInit | Ts |
|-------|----------|------|---------|----|
| RMS 1 | on       | 60   | 120     | 0  |
| RMS 2 | on       | 60   | 120     | 0  |

**Table 12. Voltage Sensor Block Properties**

| Name            | Component Path                        | Component Variants                    | Component Variant Names | Class Name | Schema Version |
|-----------------|---------------------------------------|---------------------------------------|-------------------------|------------|----------------|
| Voltage Sensor  | foundation.electrical.sensors.voltage | foundation.electrical.sensors.voltage | voltage                 | voltage    | 1              |
| Voltage Sensor1 | foundation.electrical.sensors.voltage | foundation.electrical.sensors.voltage | voltage                 | voltage    | 1              |
| Voltage Sensor2 | foundation.electrical.sensors.voltage | foundation.electrical.sensors.voltage | voltage                 | voltage    | 1              |

## Appendix



|               |                |       |         |       |       |        |  |
|---------------|----------------|-------|---------|-------|-------|--------|--|
| avg           | number         | value | value   | value | value | value  | value  |
| U +/-<br>/GnD | Port<br>number | off   | Inherit | auto  | auto  | Dialog | held<br><br>DC bus<br>Scope U in Siemens<br>DC bus |

**Table 5. PMIOPort Block Properties**

| Name | Port | Side  |
|------|------|-------|
| +    | 2    | Right |
| -    | 1    | Right |

**Table 6. PS-Simulink Converter Block Properties**

| Name                   | Physical Domain       | Sub Class Name | Left Port Type | Right Port Type | Pseudo Periodic | Unit | Affine Conversion |
|------------------------|-----------------------|----------------|----------------|-----------------|-----------------|------|-------------------|
| PS-Simulink Converter4 | network_engine_domain | ps_output      | input          | output          | off             | 1    | off               |
| PS-Simulink Converter5 | network_engine_domain | ps_output      | input          | output          | off             | 1    | off               |
| PS-Simulink Converter6 | network_engine_domain | ps_output      | input          | output          | off             | 1    | off               |

**Table 7. Voltage Sensor Block Properties**

| Name            | Component Path                        | Component Variants                    | Component Variant Names | Class Name | Schema Version |
|-----------------|---------------------------------------|---------------------------------------|-------------------------|------------|----------------|
| Voltage Sensor  | foundation.electrical.sensors.voltage | foundation.electrical.sensors.voltage | voltage                 | voltage    | 1              |
| Voltage Sensor1 | foundation.electrical.sensors.voltage | foundation.electrical.sensors.voltage | voltage                 | voltage    | 1              |
| Voltage Sensor2 | foundation.electrical.sensors.voltage | foundation.electrical.sensors.voltage | voltage                 | voltage    | 1              |

## Appendix

**Table 8. Block Type Count**

| BlockType          | Count | Block Names  |
|--------------------|-------|--|
| Voltage Sensor (m) | 3     | <a href="#">Voltage_Sensor</a> , <a href="#">Voltage_Sensor1</a> , <a href="#">Voltage_Sensor2</a> |

# Appendix F

During the design process of the simulation model, some experiences on what type of components should be used when simulating dynamic models are made. Recommendations is for Matlab r2014a.

All components used in dynamic simulations should be found in the library browser under Simulink → Simscape → SimPower system → Simscape components. If components from Simulink need to be used (for control or measurement) in combination with Simpower, a converter found in Utilities can be used for transformation between the two types of components (not for electrical signals.)

When combining the two systems, please avoid to mix the electrical signal (square connections) from the two systems. Signal blocs for measuring signals and control signal can be mixed with the help of the converter.

It is important to notice how the connection point at each component looks like, since it can only be connected to the same type of connection.

**Controls for Converter** from SimPower components can be found by writing the following in the command text window of Matlab r2014a: `pe_voltage_sourced_converter_flb` or `pe_voltage_sourced_converter_spwm`

The best components for dynamic simulation is the SimPower component in the right column. It is important to remember that the components in the right coloumn cannot be mixed with components from the left column.

Notice the difference between electrical signal (square port) and control/measurement signal (arrow) Filled squares and thin arrows are used in SimPower components, and opposite in powerlib.









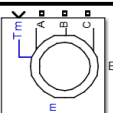

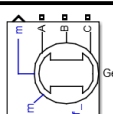
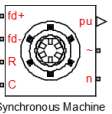
| Powerlib components   | SimPower components   |
|---|---|
|  Universal Bridge 7                |  Converter   |
|  Battery2                          |  Battery   |
|  Voltage Measurement               |  Voltage Sensor                                    |
|  Three-Phase V-I Measurement eng 7 |  Phase Voltage Sensor                             |
|  Engine                            |  Asynchronous Machine Squirrel Cage (fundamental) |
|  Generator                         |  Synchronous Machine Round Rotor (fundamental)    |

Figure 1 Comparison of power lib figures and SimPower components