



Norwegian University of
Science and Technology

A pervasive app for a better management of energy and transportation

Gamification to link activity, carbon footprint,
energy consumption and commuting patterns
to achieve positive lifestyle changes

Céline Minh

Master in Information Systems

Submission date: June 2017

Supervisor: Sobah Petersen, IDI

Co-supervisor: Idar Petersen, SINTEF Energy
Peter AHCIN, SINTEF Energy

Norwegian University of Science and Technology
Department of Computer Science

Abstract

SINTEF Energy is developing a Smart Decision Support System for Urban Energy and Transportation (DESENT). A better management of home energy and transportation has multiple benefits including savings and a significant reduction of carbon footprint. In addition, being more active, by cycling instead of driving, has many health benefits.

In this thesis we will develop an app to increase the user's awareness about its own contribution to the climate change, and motivate the user to change her/his behaviour to a more sustainable one. This app will collect and process data regarding the user's travels and energy consumption. The development leans on previous research on behaviour change theories, persuasive computing and gamification. The app is inspired from "fitness app", as they often lead to durable behaviour changes, and their usage is growing.

The thesis will describe the app's concept and features. The thesis proposes a user interface which implements a part of DESENT's requirements. An app with those requirements was implemented, so as to add incrementally more features in the future. The thesis includes an evaluation of this app with multiple user testing sessions, involving both targeted users and experts.

Preface

This thesis is the continuation of the semester project conducted in the fall the 2016, and concludes my Master of Science in Computer Science at the Department of Computer and Information Science (IDI) at the Norwegian University of Science and Technology (NTNU).

I would like to use this opportunity to sincerely thank everyone who contributed in some way to this thesis. I would like to thank:

- My supervisor, Sobah Abbas Petersen from the Departement of Computer and Information Science (IDI), for her guidance and constructive feedbacks throughout the year,
- My external supervisors, Peter Ahcin for his availability and for always being in a good mood, and Idar Petersen for his advice,
- Every person from NTE who participated in workshops for DESENT, specially Rikke Stoud Platou for their organization,
- Françoise Coste for the spellcheck,
- Everyone who participated in user tests,
- Maël Moreau, for the nice time we had studying together,
- My family, my parents, grand-parents, my sister and Erwan, for their unconditional support in my studies.

Contents

Table of Contents	iii
List of Figures	x
List of Tables	xi
List of Acronyms	xiii
I Pre-study	1
1 Introduction	3
1.1 Motivation	3
1.2 Project context	4
1.3 Problem definition	4
1.4 Contribution	5
1.5 Research questions	5
2 Research methods and process	7
2.1 Process	7
2.1.1 Research process	7
2.1.2 Development process	7
2.2 Requirements elicitation	9
2.2.1 Brainstorming sessions	9
2.2.2 Literature review	9
2.3 UI Design	9
2.3.1 Iterative design	9
2.3.2 Prototyping and co-design	9
2.4 Evaluation and data generation	10

3	Literature review	11
3.1	Behaviour Change theories and persuasive technologies	11
3.1.1	The transtheoretical model of behaviour change	11
3.1.2	The COM-B model	12
3.1.3	Intrinsic and extrinsic motivation	13
3.1.4	Persuasive technology	13
3.2	Pervasive computing	13
3.3	Activity devices	13
3.4	Feedbacks	14
3.4.1	Feedbacks and goal-setting	14
3.4.2	Comparative feedbacks	15
3.4.3	Gamification and games	15
II	Development	17
4	Requirements	19
4.1	NTE workshop	19
4.1.1	Goals and challenges of the app	19
4.1.2	App features and comparison with other apps	20
4.1.3	Evaluation	21
4.1.4	Further work	21
4.1.5	Conclusion	21
4.2	SINTEF workshop	22
4.2.1	App concept and challenges	22
4.2.2	Research methods and relevant technologies	23
4.2.3	App features and requirements	23
4.2.4	Goals and challenges	24
4.3	Requirements specification	24
4.3.1	Functional Requirements	24
4.3.2	Non functional requirements	27
4.3.3	Constraints	27
5	UI Design	29
5.1	Co-design sessions	29
5.1.1	Session 1	29
5.1.2	Session 2	32
5.1.3	Session 3	33
5.1.4	Session 4	35
5.1.5	Conclusion	37
5.2	User Interface	38
5.2.1	Earth metaphor	38
5.2.2	Colour code	38
5.2.3	Circular indicators	39
5.2.4	Graphs	41
5.2.5	Estimation buttons	41

5.3	Prototype	43
6	Technology selection	47
6.1	Proto.io	47
6.2	Python	47
6.3	Android	47
6.3.1	Mobile app: native, hybrid, or web app	47
6.3.2	SDK version	48
6.3.3	Android Virtual Device	48
7	Architecture	51
7.1	System overview	51
7.2	Backend calculations	52
7.2.1	Communication with Solkart, an external website	53
7.2.2	Outputs	53
7.2.3	Data file generation	53
7.3	Software behaviour	54
7.3.1	Use cases	54
7.3.2	Single activity - multiple fragments approach	54
7.3.3	Fragments and components description	54
7.3.4	Screens description	56
7.4	Software structure	59
7.4.1	Project files	59
7.4.2	Class diagram	60
III	Evaluation	63
8	User Interface Evaluation	65
8.0.1	Questionnaire design	65
8.1	Prototype evaluation: evaluation by an expert	66
8.1.1	Conduct of the workshop	66
8.1.2	Discussion	66
8.1.3	Results	68
9	User Experience Evaluation	71
9.1	Quick findings	71
9.1.1	Critical stage of the earth metaphor	71
9.1.2	App interpretation	72
9.1.3	Navigation	73
9.2	Questionnaire design	73
9.2.1	Concept evaluation	73
9.2.2	Usability	74
9.2.3	General questions	74
9.3	SINTEF - User testing session	75
9.3.1	Aim of the session	75

9.3.2	Conduct of the event	76
9.3.3	Observation	77
9.3.4	Discussion	77
9.3.5	Debriefing and conclusion	78
9.4	NTE - User experience evaluation	78
9.4.1	Conduct of the event	78
9.4.2	Observations	79
9.4.3	Results	79
9.4.4	Analysis	81
10	Discussion	85
10.1	Design choices	85
10.1.1	Cognitive dissonance[22]	85
10.1.2	Calories	86
10.2	Methods	86
10.2.1	Prototyping	86
10.2.2	Evaluations	86
11	Conclusion and further work	89
11.1	Conclusion	89
11.2	Further work	89
	Appendices	94
A	Questionnaires	97
B	Screenshots	105
B.1	Tutorial slides	105
B.2	App	109
C	Calculations	117
C.1	Cost of solar power	117
C.2	Cost of driving	118
C.3	Emissions from electricity consumption	119
C.4	Emissions from driving	119
D	Data file sample	121
E	Project files	123

List of Figures

1.1	DESENT description	4
2.1	Research process	8
2.2	Development process	8
3.1	COM-B model	12
5.1	Codesign session 1	31
5.2	Codesign session 2	33
5.3	Original Earth metaphor	34
5.4	Codesign session 3	35
5.5	Codesign session 4	37
5.6	Modified earth metaphor	39
5.7	Circular indicators for calories, carbon footprint and expenses	40
5.8	Graphs	41
5.9	Estimation buttons	42
5.10	Dashboard	43
5.11	Dashboard with cycling estimation	43
5.12	Carbon footprint per day	44
5.13	Carbon footprint per week	44
5.14	Carbon footprint per month	45
6.1	Platform Versions - Data collected during a 7-day period ending on March 6, 2017[1]	49
6.2	Screen Sizes and Densities - Data collected during a 7-day period ending on March 6, 2017[1]	50
7.1	System Overview	52
7.2	Use cases diagram	54
7.3	Dashboard fragments	57
7.4	Day fragments	57
7.5	Graph fragments	58
7.6	Pad fragments	58
7.7	Src folder	59

7.8	Res folder	59
7.9	Simplified class diagram	61
9.1	Starting screen	72
9.2	App running on a mobile device	76

List of Tables

4.1	Goal setting and feedbacks requirements	24
4.2	Data visualization requirements	25
4.3	Estimation requirements	25
4.4	Social media requirements	26
4.5	Settings requirements	26
4.6	Calculations requirements	26
4.7	Non functional requirements	27
4.8	Constraints	27
5.1	Codesign sessions summary	38
8.1	Heuristics evaluation results	69
9.1	Concept evaluation results	80
9.2	Usability evaluation results	80
9.3	General evaluation results	81

List of Acronyms

API Application Program Interface.

BC Behaviour Change.

DESENT Smart Decision Support System for Urban Energy and Transportation.

IT Information Technology.

OS Operating System.

SDK Software Development Kit.

SUS System Usability Scale.

TTM Transtheoretical model of behaviour change.

UI User Interface.

UX User Experience.

Part I

Pre-study

Chapter 1

Introduction

This chapter will introduce the motivation of the project and describe the project context. The chapter will also explain my contribution and specify the research questions.

1.1 Motivation

Global warming is one of the biggest and most urgent issues facing the world today. Transportation, electricity and heat production are responsible for a large part of greenhouse gases emissions[14], which contribute to climate change. Households have multiple opportunities to reduce their carbon footprint, including energy conservation behaviours, the use of more energy efficient vehicles or the installation of insulation products.

In addition, a survey from Statistics Norway [41] shows that on average 50% of the household's incomes are spent on housing, energy and transportation. Savings can be made with a better energy management. Furthermore, moderate-intensity physical activity such as cycling has significant health benefits[34]. While physical inactivity is raising in many countries, walking or cycling for short trips instead of using private cars can help achieve the recommendations on physical activity from the WHO¹.

These assessments encourage to increase awareness about one's contribution to global warming, and the health and financial benefits of a more sustainable behaviour. This thesis will present the development of an app that collects personal data related to energy and transportation, in order to support better decisions regarding energy and encourage people to adopt as well as maintaining a more sustainable behaviour.

¹WHO: World Health Organization

1.2 Project context

This master's thesis was conducted within the European project DESENT (Smart Decision Support System for Urban Energy and Transportation).

In cooperation with partners from Helmond (Netherlands), Steinkjer (Norway), and Weiz (Austria), SINTEF Energy is developing a smart decision support tool for house energy and transport usage. The project is described conceptually in Figure 1.1.

The power company NTE contributes to DESENT, and has been involved in the design and test of the app during this thesis.

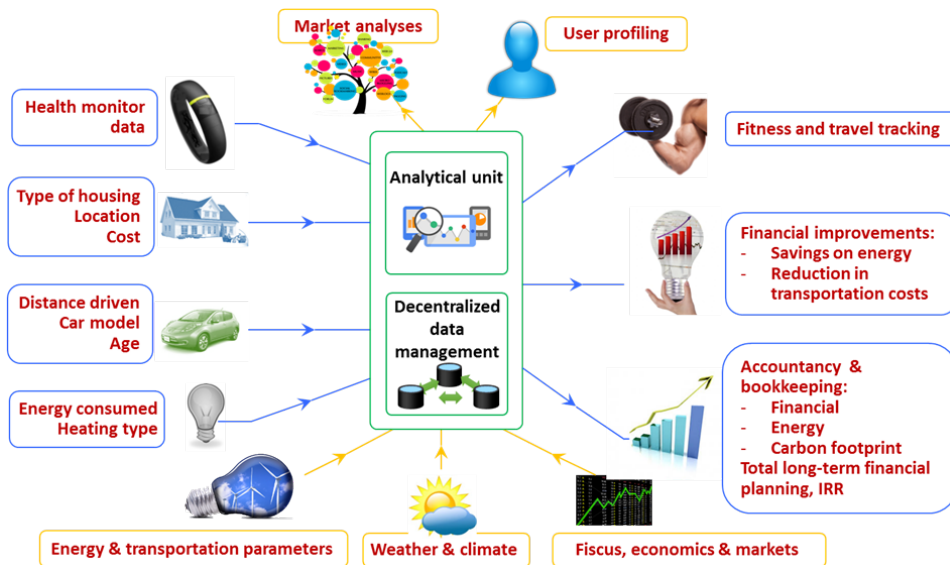

Figure 1.1: DESENT description²

1.3 Problem definition

The app is addressed to the general public. It targets more specifically adults, as it involves energy installations and means of transportation. The app is addressed to people who are enthusiastic, but not experts, about mobile technologies and energies. This app should be accessible for people who do not necessarily have a strong knowledge regarding the energy domain.

The app aims at helping the user to achieve a behaviour with a lower cost and environmental impact. The app will promote the installation of more sustainable

²Figure made by Peter Ahcin

equipment, and the use of more sustainable means of transportation.

The app will collect information about the user in a pervasive way. The app must motivate the user with personalized goals, showing the impact of lifestyle changes on health, carbon footprint and energy consumption, based on an analysis of the user's household/vehicle energy use.

1.4 Contribution

This master thesis will contribute to the project DESENT by providing the following:

- A concept definition and a requirements specification for the app,
- An API that contains a set of functions and classes for the backend calculations,
- A description of the software architecture,
- An app that implements features related to the research questions,
- An evaluation of the app.

1.5 Research questions

The thesis' main research question can be formulated as follow:

How can a mobile app help achieve positive lifestyle changes?

In order to address this question, we will split it into four smaller ones:

RQ1: How can we collect personal information regarding energy and transportation by limiting the user's inputs?

RQ2: Can gamification motivate the user to adopt and maintain a more sustainable behaviour?

RQ3: Can the visualization of personal data and feedback about the user's behaviour trigger interest and increase awareness about energy?

RQ4: Can the combination of health benefits, environmental impact and economic profit motivate people to manage energy better?

Chapter 2

Research methods and process

This chapter will describe the thesis' research process, and the relevant methods at each stage of the process.

2.1 Process

2.1.1 Research process

The research process is described in Figure 2.1, and includes:

- A pre-study that includes the motivation, the definition of the research question and the literature review
- The design and creation of a piece of software
- The evaluation of the software

2.1.2 Development process

The software process was agile: the focus of each process activity has been defined incrementally over time. Figure 2.2 describes the effective development process, the product of each process activity, and the evaluation performed.

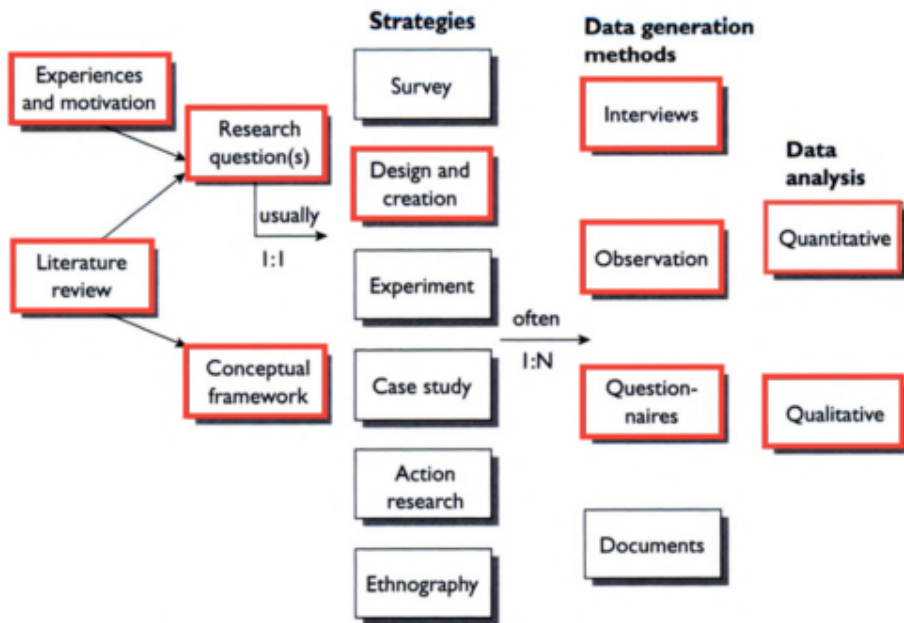

Figure 2.1: Research process [33]

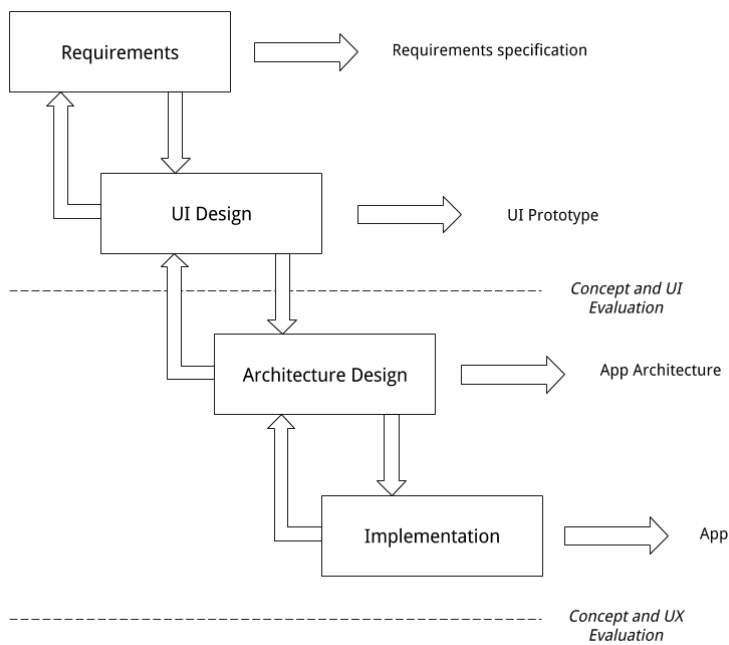

Figure 2.2: Development process

2.2 Requirements elicitation

2.2.1 Brainstorming sessions

Brainstorming sessions consist in informal discussions with stakeholders to generate as many ideas as possible[48]. They helped develop innovative and creative solutions to a problem[35].

Two brainstorming sessions were conducted during the pre-study: one with NTE (Section 4.1), and another one at SINTEF (Section 4.2). They aimed at collecting requirements for the app, which will be further evaluated.

2.2.2 Literature review

This thesis addresses behaviour change problems. The literature review allowed me to build a theoretical background and define the research questions.

In addition, the literature review allowed me to analyze, evaluate and prioritize requirements. In particular, I then used a book, *The Behaviour Change Wheel: A Guide to Designing Interventions* [30], that introduces a model of behaviour change, and presents a taxonomy of behaviour change techniques to act on specific points described by the model.

2.3 UI Design

2.3.1 Iterative design

The design has been conducted in an iterative way. There were two main iterations:

1. A first iteration for designing the user interface
2. A second iteration when I implemented and improved the first prototype.

Those main iterations included smaller iterations, evaluated by:

- Regular meetings with my supervisors,
- Small user testing sessions with one or two users.

2.3.2 Prototyping and co-design

The UI design involved several co-design sessions together with one of my supervisors, Peter AHCIN.

Those sessions aim at being more creative, as they allow participants to share ideas, solve and bring problems up when designing. Co-design sessions helped create a product that fits Peter's vision.

The co-design sessions allowed me to refine the requirements defined during the pre-study, adding new ones and prioritizing them.

2.4 Evaluation and data generation

The product had two main evaluations:

1. A concept and UI evaluation with one representative of NTE (Chapter 8)
2. A user experience evaluation with four representatives of NTE (Chapter ??)

For both evaluations, data was collected from interviews, observations and questionnaires. The data analysis was mainly qualitative. The questionnaires aimed at quantifying data, but was addressed to only few participants.

In addition to those main evaluations, several informal user testing sessions were performed through the design and implementation process, in order to identify usability problems and solve them. Those tests were quick and usually aimed at solving one single issue. The quick findings reports were then informal and only the most important elements are summarized in this thesis (Section 9.1).

Chapter 3

Literature review

3.1 Behaviour Change theories and persuasive technologies

3.1.1 The transtheoretical model of behaviour change

The transtheoretical model of behaviour change (TTM) [19] identifies six stages of change:

1. **Precontemplation:** individuals do not consider changing their behaviour, this can be due to a lack of awareness of the consequences of their behaviour.
2. **Contemplation:** individuals are intending to change, but not immediately, and are more aware of the change benefits.
3. **Preparation:** individuals are intending to take action in the near future.
4. **Action:** a change is observable, individuals have to work hard to keep their new behaviour.
5. **Maintenance:** keeping the behaviour is easier, but individuals may be tempted to go back to their previous behaviour.
6. **Termination:** there is no more risk for individuals to go back to their previous behaviour.

The TTM can be used to provide more effective energy feedbacks. The paper *One Size Does Not Fit All: Applying the Transtheoretical Model to Energy Feedback Technology Design* [17] proposes strategies to target individuals at different stages of change, taking into account the stage of "readiness, willingness and ableness" of the individual.

3.1.2 The COM-B model

The COM-B model (Capability Opportunity Motivation - Behaviour) is the starting point used by the Behaviour Change Wheel. According to that model, a person will adopt a behaviour only if she/he has the capability to do it, the opportunity for the behaviour to occur, and sufficient motivation (figure 3.1).

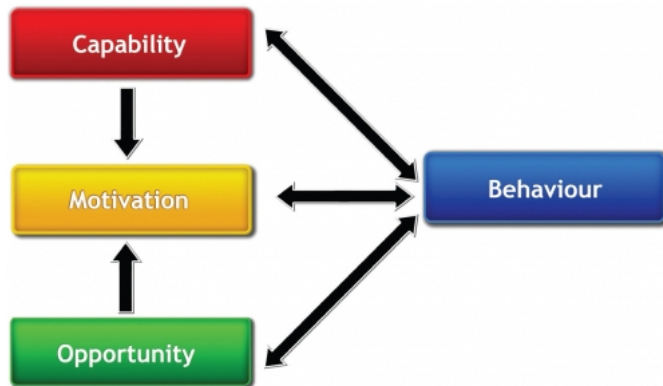

Figure 3.1: COM-B model

The arrows shows that increasing capability or opportunity can increase motivation, but motivation alone cannot give the capability or opportunity to adopt a behaviour.

Each component of the COM-B model can be divided as follows:

- The capability can be physical (having the physical skills to perform the behaviour) or psychological (knowledge). In the project context, a user will not be able to cycle to work instead of driving if he/she does not have a good enough condition to cycle until his/her working place (physical capability). A person will not consider replacing his/her car with an electric car if he/she does not have knowledge about the environmental impact of those (psychological capability).
- The opportunity can be either physical or social. If there is no solar panel seller in the user area, then he/she does not have the physical opportunity to buy one. If the majority of the users's colleagues go to work by bike, it increases the social opportunity to cycle.
- The motivation can be reflective or automatic (being motivated by a reward). The reflective motivation involves a cognitive process: for example, being motivated by having a lower environmental impact. The automatic motivation involves emotional reaction, for example being motivated by a reward.

3.1.3 Intrinsic and extrinsic motivation

There are two types of motivation: intrinsic and extrinsic motivation.

- "Intrinsic motivation is defined as the doing of an activity for its inherent satisfactions rather than for some separable consequence." [36]
- Extrinsic motivation is performing a behaviour in order to obtain some reward or avoid punishment [23].

Extrinsic motivation can be a reward or a badge. Increasing intrinsic motivation rather than extrinsic motivation increases the probability that someone sticks to a behaviour [27]. Malone wrote a Theory of Intrinsically Motivating Instruction, when he highlighted three main elements that make a game motivational: challenge, fantasy, and curiosity [28]. Lepper proposed four design principles for intrinsic motivation: control, challenge, curiosity and contextualization [23].

3.1.4 Persuasive technology

Persuasive technology refers to technology that is designed to change the user's behaviour.

Fogg considers computers as "persuasive social actors" [11], and observed that users interact with computers as if they were human beings. Computers can then have a social influence, and motivate or persuade users by providing feedbacks or social support. A research project had positive results by designing a virtual polar bear to motivate energy conservative behaviours [7].

3.2 Pervasive computing

Pervasive systems can involve continuous active monitoring of user behaviours, give feedbacks when a bad behaviour occurs, and correct it [26].

A Norwegian project, City-Sense-MOB [3] collects data related to air-quality by equipping citizens with small and cheap sensors, and asking them to report symptoms. In addition to providing information about air quality, they expect that involving the citizens in the data collection process will make them more aware and conscious of environmental issues.

3.3 Activity devices

A Study of Long-Term Use of Activity Sensing Devices for Fitness [13] has shown that participants integrated the devices to their routine, were strongly attached or obsessed by them, and developed a strong awareness about the value of their activity. In addition, the participants observed an immediate and durable change on their behaviour. However, many participants felt frustrated when they were

walking or exercising without their devices, because it would have been rewarded. The study showed that the social features for sharing data were not always used, some participants did not find any interest in sharing their progress with their friends.

The increasing use of devices to collect fitness data represents an opportunity for smart cities. Fitness data can be reused for environmental monitoring, especially for walking and cycling, to calculate the savings in transportation, and the health and environmental benefits [5].

3.4 Feedbacks

Many systems use constraint-based techniques to force a behaviour change. Persuasive systems with less coercive methods are perceived as more friendly [26].

Van Houwelingen and Van Raaij [44] outlined three main functions of feedback:

1. A learning function,
2. A habit formation function,
3. An internalization of behaviour.

3.4.1 Feedbacks and goal-setting

According to Locke [25], goals and feedbacks are inseparable, "feedback represents information and qua (unevaluated) feedback is affectively neutral". Indeed, feedback helps see where the user is in relation to his/her goal [29].

A research project, BeAware [2], built a list of requirements for designing effective feedbacks of electricity consumption based on a literature review [20] including:

- The feedbacks have to be related to a main conservative goal (and not only display the value of the energy consumption),
- The feedbacks have to be tailored to the household's actual consumption,
- The feedbacks have to be close to the user's action. Affecting specific behavioural intentions is easier than affecting the overall behaviour.
- The feedbacks have to be remembered when needed.

Studies have shown that feedback and goal-settings generate immediate effect from an energy-wasting behaviour to an energy-conservative behaviour [29].

However, setting energy saving goals assumes that users already want to save energy. Some users do not have an energy saving goals and would prefer other ones (comfort or convenience) [29]. When designing interventions, it can be then necessary to trigger a energy saving goal to reach this category of users [38].

3.4.2 Comparative feedbacks

A survey on comparative feedbacks [39] has studied the effect of comparative feedbacks. They gave feedbacks and set goals related to energy conservation to two teams, and gave one of the teams the results of the other ones. They concluded that comparative feedback had a much larger impact on energy-wasting behaviour than the program excluding comparison.

Another survey [37] has highlighted a "destructive boomerang effect" of comparative feedbacks. They gave feedbacks to a large sample of participants (290 households): their energy consumption, if they were above or below the average, and tips to reduce their energy consumption. They observed a decrease of energy consumption in the groups who had initially a high energy consumption. However, they observed that people who had a low energy consumption increased it after receiving feedback, while managing in order to stay below the average.

3.4.3 Gamification and games

"Gamification is the application of game-design elements and game principles in non-game contexts" [18]. Game-based techniques are used to promote engagement, and differs from serious games [21].

An analysis of the results of several pervasive [15], persuasive games for energy conservation has shown that behaviour changes have been observed when users were playing the games. Some of the projects evaluated long-term behaviour changes, and concluded that behaviours were not maintained after the game stopped.

An evaluation of IdleWars [43] brought interesting results. The game had good results in terms of engagement, but no awareness increase has been observed. It has also been observed that participants were adding rules in the game in order to make it more fun, and sometime against the purpose of energy conservation.

Part II

Development

Chapter 4

Requirements

This chapter will describe the requirements elicitation process. The chapter starts by summarizing the two workshops, that included brainstorming sessions, and aimed at gathering requirements. The chapter ends with the requirements specification.

4.1 NTE workshop

This section summarizes and categorizes the ideas formulated during the three-hours workshop that took place on January 17, 2017 at NTE's office in Trondheim. Four representative of NTE and my three supervisors participated to the workshop.

The objectives of the workshop are:

- The identification of the app's goals,
- The identification and prioritizing of requirements and features.

4.1.1 Goals and challenges of the app

During his presentation, Peter mentioned that he interrogated our "demo cities" about which features they would be most interested about. In Weiz (Austria), they were more interested in information about heating, and in Helmond (Netherlands), they were more interested in mobility.

Throughout the workshop, the representatives of NTE pointed out the fact that the app should focus only on transportation. They added that the concept should be reduced and the app has too many objectives. The project has to emphasize simplicity rather than usefulness.

In addition, the car aspect is very important, and the app has to promote the use of the bicycle and car sharing. In order to reach this goal, the energy aspect

can be invisible for the user. DESENT has to find the incentives that make people move with less emission.

4.1.2 App features and comparison with other apps

Everyone who was present in the workshop agreed to put a lot of efforts in the attractiveness of the design, in order to bring interest. As the app should be used daily, the design has to be simple, with a limited number of features.

Another crucial point of the app will be the context-awareness. It has to require a limited amount of inputs from the user. A popular health app was mentioned as a terrible example, because it requires manually entering all the food eaten during a day, that is considered as a source of annoyance by users. Energiportalen¹ can be used to collect data, as it contains public information about houses consumption. In addition, the tracking has to start automatically when a user starts travelling, as Samsung Health² does.

One goal of the app is to create awareness about energy consumption. It should inform people of their means of transportation and will contain a dashboard showing the following indicators:

- Calories consumption,
- Savings,
- Carbon footprint.

It could be interesting, based on the habits of a user, to explain possible deviations, that could be a sudden change in the gas emissions.

The app should provide a scoreboard, and compare it with other users. In addition, the app has to provide the possibility to collaborate and/or compete with other users.

Another crucial point raised during this workshop was a reward system, that could not be only virtual. Erik pointed the fact that some companies were giving physical rewards for exercising, and added that it was successful. A physical reward may be given to users that reach their emission save, or another daily goal. It could be a discount on an electric car, a free bus ticket or a lock for a bike. The municipality could be involved in giving such rewards.

One part of the workshop was dedicated to presenting the project Mitt Energi-hjem³, which aims at creating awareness about energy consumption. The app

¹Energiportalen: <http://trondheim.energiportalen.no/>

²Samsung Health: <http://www.samsung.com/global/galaxy/apps/samsung-health/>

³Mitt Energi-hjem <http://www.nteinnovasjon.no/prosjekter/mitt-energi-hjem>

provides a visualization of user consumption. It shows both real-time and historical data. The app can simply gather information about a user (power agreement, cabin, home, Internet) with entering a phone number. The user can make simple calculations to see the impact of changing a window, or installing a solar panel for example. The app can alert the user, and push relevant information. The app provides also a chat with somebody from NTE, and includes a webshop and a social media aspect. This review has to be kept in mind, as the DESENT app may be integrated in Mitt Energihjem.

4.1.3 Evaluation

The evaluation methods were discussed during the workshop. Several evaluations have to be performed during the semester:

- A prototype evaluation,
- A user interface evaluation, even without the backend,
- An evaluation of the final app.

The prototype evaluation can be performed during a workshop, gathering researchers involved in DESENT.

However, a user experience testing should be organized, including potential users that have no experience in the energy or IT domain. NTE offered to find users, depending on what the goal of the app is. In addition, NTE can be considered as a demo site, as they want to increase the use of bicycle.

We have to consider testing the app in the city, someone from the municipality could be involved to perform such testing.

4.1.4 Further work

The next step will be to develop a list of features, game concept and sketches for the user interface. Few features have to be eliminated. The user interface has to be discussed with few people.

During a debriefing session with my supervisors, we decided to keep the energy aspect of DESENT, contrary to what NTE suggested. In fact, the core of DESENT is to evaluate somebody's lifestyle. However, the energy and transportation aspects have to be sufficiently separated to allow NTE to use only the transportation part.

4.1.5 Conclusion

During the meeting, NTE expressed its interest for the transportation aspect of DESENT. The app aims at increasing awareness about the impact of their habits

in terms of gas emission, expenses and health. In order to reach that goal, we have to find the incentives that will motivate people to use our app.

The app will include the following features:

- A dashboard, showing the impact of user's habits in term of gas emission, saving and calories burned,
- An automatic collection of data,
- A reward system, that could be physical,
- A scoring system,
- A social media aspect, that supports collaboration and/or competition.

4.2 SINTEF workshop

This section relates the first meeting with my supervisors only, after the NTE workshop. The meeting took place at SINTEF Energy and was two hours long.

The objectives of the meeting were:

- The definition of the thesis objectives,
- The definition the app concept and challenges,
- The identification, prioritization and selection of requirements/features,
- The definition of research methods and identification of relevant technologies,

4.2.1 App concept and challenges

The meeting started with a discussion about gas emissions. Idar underlined issues related to the assessment of somebody's gas emissions. Indeed, the emissions due to heating depend on the place someone lives in. If somebody uses more energy for heating because she/he lives in a cold place, it could be unfair to compare her/him to somebody who lives in a warm place without taking into account this criteria. The number of people sharing a house is also relevant to assess one's lifestyle.

In addition, the gas emissions using public transportation depend on the number of people who are taking the bus/train. It is then difficult to estimate properly somebody's gas emission. Making the distinction between car or bus is also difficult to do in a pervasive way. We decided to prioritize what we can do now, and consider this kind of issues for future work. In addition, Peter and Idar will take care of establishing a temperature profile.

4.2.2 Research methods and relevant technologies

Sobah highlighted the need of looking at theory, and base our choices on a literature review. During the workshop at NTE, the blockchain architecture was mentioned. If we have enough time, we have to search what it means, and if it is relevant for our work. A technology review, that may include relevant architectures (Blockchain, Hadoop), has to be performed, as well as a documentation of the methods used. For the first app, we can still use the actual architecture and describe simultaneously a more relevant architecture, maybe without implementing it.

As Peter was enthusiastic about working on the interface, we decided to plan co-design sessions together, and start making sketches.

Idar mentioned GoldenCheetah⁴ for tracking movement.

In order to evaluate behaviour, it is important to include as soon as possible the user in the evaluation of the app. So, a working app has to be ready soon, with limited features. New features may be added incrementally then. The front-end can work as a motivation for more business models. For evaluating a first prototype/app, we have to:

- Evaluate how people enjoy it
- Evaluate how they communicate it
- Make a choice between looking at a group data or individual data
- Look at articles about evaluation
- Consider using a local database
- Estimate a daily value

4.2.3 App features and requirements

Fictional character

We mentioned the idea of making fictional character as avatars. Sobah found the idea motivating, and thought it can be useful to solve cognitive conflicts. She illustrated the idea of cognitive conflicts with the example of healthy food for children: they do not understand why eating ice-creams can be bad, if it makes them happy to eat them. Using a bad character when eating too many ice-creams is a good educational way to make them understand that it's bad.

Idar imagined having on one side a green Superman, and on the other side a brown, lazy and fat monster, or even something that is not usually associated with ecology, for example a fish that evolves to become a shark.

⁴GoldenCheetah: <http://www.goldencheetah.org/>

Data visualization

Idar proposed to start easy, with the visualization of numbers. Sobah added that it is important to see how it can be associated with a bad behaviour. The level of granularity of historical data has to be appropriate for the use of a smartphone.

4.2.4 Goals and challenges

I proposed an idea of a weekly challenge that groups random participants in several teams that compete between them. It involves a fictional pet character (or a tree) with a certain number of HP. The pet could grow by completing daily challenges or reaching a daily goal, and lose HP when a team member has too bad a carbon footprint. If the pet loses all its HP, then the team loses. At the end of the week, the winning team would be the one with the most evolved virtual pet.

Metaphors

We discussed the use of metaphors to explain global warming. Idar mentioned the raise of the sea level. Sobah mentioned that a metaphor can be used, rather than a graph, to produce something collaboratively, regarding the game idea I proposed.

4.3 Requirements specification

The requirements elicitation was guided by The Behaviour Change Wheel, A guide to designing interventions[30], which was developed from 19 frameworks of behaviour change and proposes a taxonomy of behaviour change techniques.

The requirements were prioritized according to their relevance regarding the research questions. In particular, social media features will not be treated in this thesis.

4.3.1 Functional Requirements

Goal setting and feedbacks

ID	Requirement	Priority
FR1	The app will provide personalized goals	Medium
FR2	The app will assess the user's behaviour regarding gas emissions	High
F3	The app will provide daily challenges to lower the user's gas emissions	Low
FR4	The app will provide a physical reward	Low

Table 4.1: Goal setting and feedbacks requirements

Data visualization

ID	Requirement	Priority
FR5	The app will display information regarding the user's behaviour on a daily-basis	
FR5-1	The app will display an approximation of the user's emissions due to the energy use at home and transportation during a day	High
FR5-2	The app will display the calories burned during the user's journey during a day	High
FR5-3	The app will display an approximation of the user's expenses due to the energy use at home and transportation during a day	High
FR5-4	The app will explain the cause of possible deviation from the user's habits	Medium
FR5-5	The app will display the number of km travelled by the user during a day	Medium
FR5-6	The app will display the user's energy consumption during a day	Medium
FR6	The app will sensitize the user about the effect of gas emissions	High
FR7	The app will display the evolution of the indicators above through time	High

Table 4.2: Data visualization requirements

Alternative behaviour

ID	Requirement	Priority
FR8	The app will display a projection of the user data with sustainable installations or/and behaviour	
FR8-1	The app will display a projection of the user data with a solar panel	High
FR8-2	The app will display a projection of the user data with an electric car	High
FR8-3	The app will display a projection of the user data by cycling/walking instead of going by car	Medium

Table 4.3: Estimation requirements

Community and social media

ID	Requirement	Priority
----	-------------	----------

FR9	The app will provide a comparison of the user's data with the community	Low
FR10	The user will be able to compare his/her results with his/her friends	Low
FR11	The user will be able to compete with other users	Low
FR12	The user will be able to join collaborative challenges	Low
FR13	The app will allow the user to share his/her results in external social media	Low

Table 4.4: Social media requirements

Settings

ID	Requirement	Priority
FR14	The user will be able to rectify the means of transportation used during a journey	Medium

Table 4.5: Settings requirements

Backend calculations

ID	Requirement	Priority
FR15	The app will distinguish different means of transportation used during a travel	
FR15-1	The app will detect walking and driving	High
FR15-2	The app will detect cycling	Medium
FR15-3	The app will detect the use of public transportation	Low
FR16	The app will estimate the gas emission during a travel	
FR16-1	Depending on the mean of transportation	High
FR16-2	Depending on the model of the user's car	Medium
FR16-3	Depending on the number of people sharing a car	Low
FR17	The transportation module will estimate the number of calories burned during a travel	
FR17-1	With a standard age, sex, weight and muscular mass	Medium
FR17-2	With the personalized parameters	Low

Table 4.6: Calculations requirements

4.3.2 Non functional requirements

ID	Requirement	Priority
NFR1	The backend calculations have to be reusable in other apps/projects	High
NFR2	The final app has to be thought to be integrated in another app	High
NFR3	The transportation and energy aspect have to be separated	Medium
NFR4	The app will limit the use of GPS in order to save battery	Low

Table 4.7: Non functional requirements

4.3.3 Constraints

ID	Constraint
C1	The user will be able to navigate offline, between each synchronization with the server
C2	The app will be compatible with Android devices

Table 4.8: Constraints

Chapter 5

UI Design

This chapter will describe the UI design process. The chapter starts by summarizing the co-design sessions with my supervisor, Peter Ahcin. It documents the contribution of each of us. The chapter ends with a description of the UI that was evaluated in Chapter 8.

5.1 Co-design sessions

The prototype was designed with a participatory approach, including mostly Peter and potential users. This section will describe the conduct of the co-design sessions and document the contribution of each of us.

5.1.1 Session 1

This co-design session followed the first meeting with Idar, Peter and Sobah (Section 4.2). This meeting included a brainstorming session, and many ideas came out from it. The aim of this session was to represent the ideas included during the brainstorming on paper.

Peter drew:

- An avatar, who evolves depending on the user behaviour. The fictional character can be a standard person, a green superhero, or a fat monster. It aims at representing the outcomes of the user's behaviour: a person who cycles a lot instead of driving would be healthy and have a lower environmental impact, when a less active person, who drives a lot, is more damaging for the environment.
- Indicators around the fictional character, about km, energy consumption, calories, carbon footprint and expenses.

I drew:

- A daily goal, that gives points.
- Three circular indicators: one for carbon footprint, one for calories, one for expenses. One is bigger than the others, and an indicator can be dragged to replace another one.
- Two alternatives for a multiplayer weekly or monthly challenge:
 - The first challenge is collaborative. Teams are formed randomly with 4-5 players and are making a common plant grow together. If someone reaches his/her daily goals, water is given to the plant and it grows. If someone exceeds his/her carbon footprint budget, it pollutes the common plant, that loses heart points. If the plants dies, the challenge is lost. If the team wins the challenge, they win a certain number of points depending on how big the plant is.
 - The second challenge supports collaboration and competition. Two teams play against each other. Each team is represented by a monster. As in the previous challenge, the way of behaving in real life affects the virtual monster. At the end of the challenge, the biggest monster beats the weakest one.
- A column with one's friends' avatars

At the end of the session, the screens contained many components. The next step was to select the most relevant components, work on the screen occupation, and work separately on a Proto.io project before the next workshop.

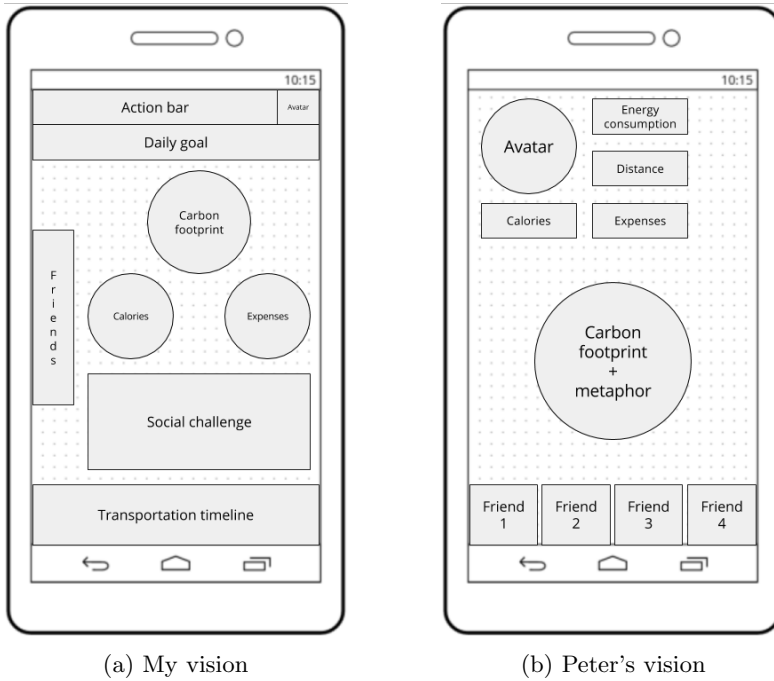

Figure 5.1: Codesign session 1

5.1.2 Session 2

Before this session, and together with Sobah, we decided to not treat the social media aspect in this thesis. Indeed, even if social features are more than relevant in this kind of app, they have already been explored and their efficiency has been proved. We decided to prioritize the most innovative aspects of this project, which are awareness about personal data, and financial and health motivation.

During this session, I presented several propositions for the main view with the following components:

- A background with several states, depending on the user's long-term behaviour. The background starts with a standard city, and become either a green city or a desert place.
- An avatar as described in session 3.
- Indicators about calories burned, expenses, and carbon footprint.
- Daily challenges.

The first proposition was the most game-oriented. The avatar was surrounded by progress bar with different colors:

- Green for carbon footprint
- Blue for money
- Red for health

The amount of calories burned, money spent on energy, and emissions were displayed below the avatar, in the same way as in role-play games. The rest of the screen was occupied by the daily challenges.

The second proposition contained the same elements as the first one, except the daily challenges, that could appear in another screen. It helped limit the amount of information on the screen.

The third proposition contained only the background and three circular indicators: one for health, one for expenses and one for carbon footprint.

Peter liked the colours and found that the components were displayed in an elegant way. However, he pointed the fact that the background and the avatar duplicated the information. After discussing, we agreed that the changeable background could represent the long-term behaviour, and the avatar could be used for giving feed-backs on users' actions.

He also made an informal survey before the session that showed that many people are not familiar with the notion of carbon footprint. We agreed on trying to find a metaphor to represent what carbon footprint is for the next session.

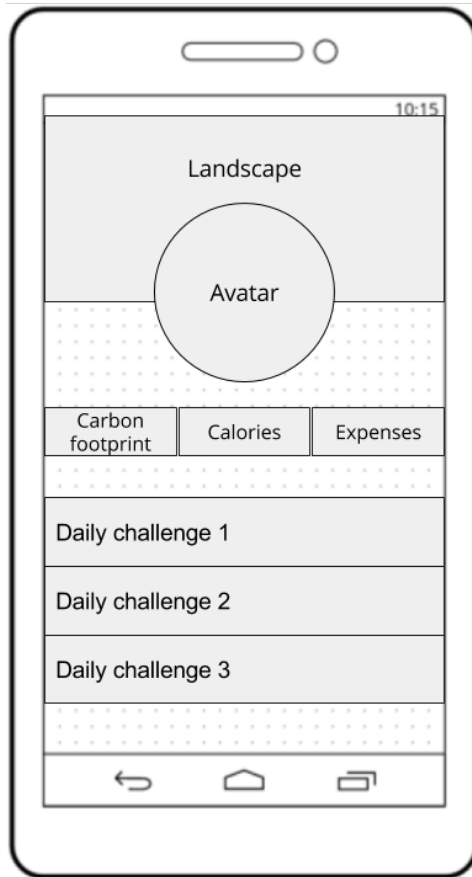

Figure 5.2: Codesign session 2

5.1.3 Session 3

In this session, Peter and I shared ideas of metaphors to show the impact of carbon footprint.

I proposed:

- An Earth, whose mood changes according to the user behaviour. When the user's carbon footprint is increasing, the Earth starts sweating and gets warmer.
- A polar bear on a pack ice. The increase of the carbon footprint is represented by the increase of the sea level, and the ice melt.
- A tree, that starts healthy and gets dry if the user's carbon footprint is too high.

- Using only the background to represent the effect of gas emissions.

On his side, Peter asked a colleague to draw an image that can represent carbon footprint, and that could be used in the project (Figure 5.3). Coincidentally, this representation fit with my first idea (Earth metaphor). However, Peter found the picture too "kitschy" and thought that it would not look good on the app. In my opinion, including a mascot is a way to give an app personality. Peter and I agreed on the fact that changes on the original picture had to be done.

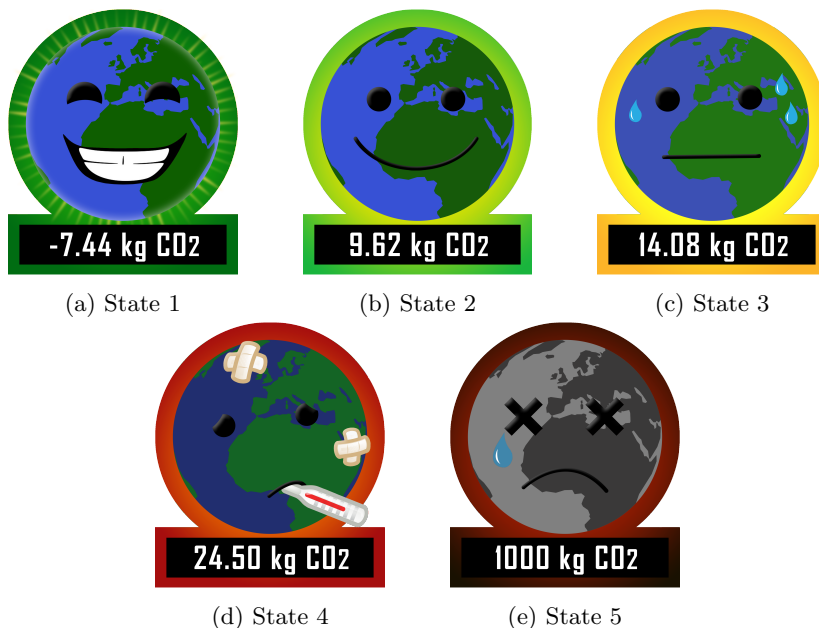

Figure 5.3: Original Earth metaphor

Together, we changed the size and disposition of the components: we reduced the background, added the numbers on the bottom of the background, keeping only the circular indicator for the carbon footprint. Afterwards, we noticed that the app looked unintentionally like Google Fit regarding the disposition of the components.

For the next session, we agreed that I should improve the overall look of the main view, include the earth metaphor in the app, and differentiate it from Google Fit.

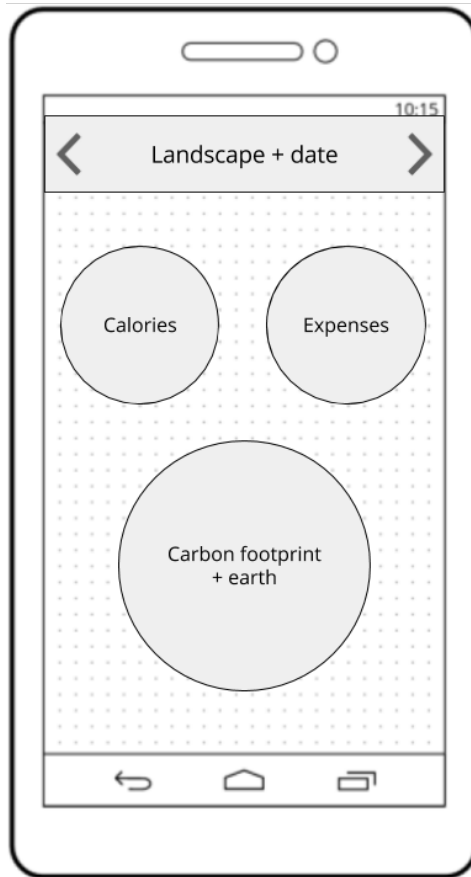

Figure 5.4: Codesign session 3

5.1.4 Session 4

Before this session, I made the following modifications on the main screen:

- I cropped the Earth picture to keep only the Earth face.
- I included the Earth metaphor into the circular indicator for carbon footprint.
- I added buttons on the prototype to estimate the values with an alternative behaviour or installations (walking, cycling, using an electric car, using a solar panel) on the bottom of the screen, according to Peter's vision.
- I added the possibility of navigating to previous days.
- I added an explicit sentence to tell the user to keep a low carbon footprint.

We had a disagreement about the number of values that should appear on the screen. Peter wanted to add energy consumption and km travelled in the day. At first, my point was that there was too much information in the screen. Peter and Idar convinced me that if they did not appear, the link with calories, expenses, and energy consumption would not be difficult to make. We made the decision to keep circular indicators for carbon footprint, calories and expenses, and display them on the top of the screen (that corresponds to motivation), and display the energy consumption and km on the bottom without circular progress bars (it corresponds to input values, and will not move with the estimation buttons). I finally decided to remove the header with the landscape.

The session concluded with a user testing activity. We asked a potential user, with no energy or IT background, to tell everything she understood on the screen. She identified the role of the indicators, but we had to give a hint about the buttons (they were only pictures without button aspect). She recognized the icons. The experience was overall successful, except for the estimation part that was not clear.

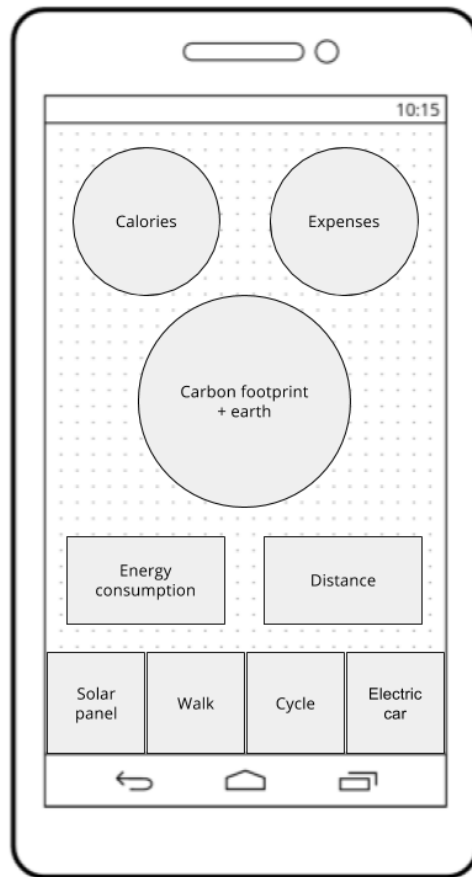

Figure 5.5: Codesign session 4

5.1.5 Conclusion

As we have seen in this section, the main screen has evolved a lot since the first brainstorming session. Many components disappeared, and the main concept of the app (the estimation of an alternative behaviour) appeared late in the design process. The table below summarizes the evolution of the app features during the design process:

Component	S1	S2	S3	S4
Daily challenges	x	x		
Social challenge	x			
Changing background		x	x	
Circular indicators	x	x	x	x

Navigation between days				x
Changing avatar	x	x		
Social media aspect	x			
Estimation buttons				x
Earth metaphor			x	x

Table 5.1: Codesign sessions summary

Finally, each component implemented the app’s requirements in different ways. We can point the fact that the majority of the components I proposed do not appear on the final version. Those co-design sessions led to creating a product closer to my supervisors’ vision.

In addition, having a visual support helped to have more constructive discussions. In fact, discussing around requirements or specifications requires more abstraction skills.

However, those sessions cost a lot of efforts, as we draw many components we did not use. Indeed, I could notice that the team was more motivated and enthusiastic when the screen ”looked good”. In addition, between the co-design sessions, duplication of work could happen. To conclude, planning those sessions was possible because Peter was highly available and involved in the design process.

5.2 User Interface

5.2.1 Earth metaphor

The prototype use a earth metaphor (figure 5.6) that has three functions:

1. To asses the user’s carbon footprint,
2. To show the impact of a high carbon footprint (global warming),
3. To create emotional attachment.

5.2.2 Colour code

The interface uses two main colours:

1. Green for what is related to transportation,
2. Blue for what is related to housing,

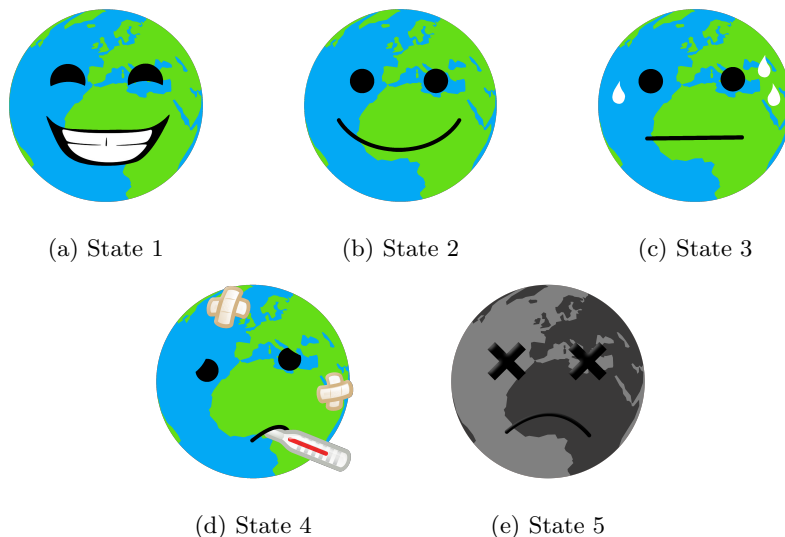

Figure 5.6: Modified earth metaphor

In addition, the color red is used in the first iteration (orange in the second one), for the calories. This is because the calories depend only on transportation, and work differently than expenses and carbon footprint (for the calories, the aim is to reach a goal, for the expenses and carbon footprint, the aim is to stay below a limit).

The rest of the interface uses shades of grey.

The choice of blue and green is to avoid the use of too many colors, as the earth image is blue and green. It also contributes to the app atmosphere: green is related to nature, and blue is a peaceful color. Red was chosen because it is the colour of health points in video-games.

The risk is that users misunderstand the colour code, and associate green with good, and red with bad. That is one of the reasons the color orange was used instead of the red in the second iteration, as it is an energetic colour. To avoid that risk, the colour red is used to draw the limit value in the case of carbon footprint and expenses.

5.2.3 Circular indicators

In order to represent the daily carbon footprint, expenses, and calories burnt, we use circular indicators (figure 5.7).

The circular indicators have 3 main functions:

1. Inform the user about his/her current value,

2. Display the daily goal or limit for each value,
3. Inform the user about his/her current state compared to the daily goal.

The value written in the circle corresponds to the actual daily value when the user looks at the app. This value is also shown by the circular bar progression.

The circular progress bar shows the position of the user's value compared to a target value. In the carbon footprint and expenses case, this value is a maximum not to be exceeded. In the case of calories, it is a goal to reach. In this prototype, we made the assumption that the user understands that a high carbon footprint and expenses is bad, but a high amount of calories burnt is good. To reinforce this idea, we added a red limit bar on the carbon footprint indicator, and small hearths on the calories indicators, that are filled when the amount of calories burnt increases.

The maximum value for expenses and the daily goal for calories is reached when the circle is completed. For the carbon footprint, the limitation is shown by a vertical red bar at the half of the circular progress bar.

The progression for the carbon footprint and expenses is divided into two parts, to show the distribution of the carbon footprint (resp expenses) into housing and transportation. The blue progress bar shows the housing part, and the green progress bar shows the transportation part.

The carbon footprint circular indicator contains the earth metaphor, with a state related to the user's current value.



Figure 5.7: Circular indicators for calories, carbon footprint and expenses

5.2.4 Graphs

The interface uses two types of graphs (figure 5.8):

1. Bar charts to display weekly data,
2. Line charts to display monthly or yearly data.

The bar charts show the distribution between housing and transportation, in the carbon footprint and expenses case.

The limit value is symbolized by a red line. In the case of calories, the daily goal is simply a grey line.

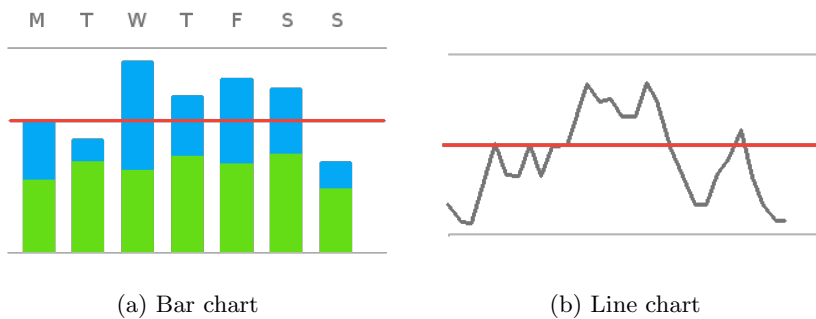

Figure 5.8: Graphs

5.2.5 Estimation buttons

The estimation buttons (figure 5.9) use simple icons to represent a solar installation, a walking character, a cycling character and an electric car. They use the colour code to indicate in which category they will have an effect, and to reinforce the colour code.

The buttons become full of colour when they are activated, to allow the user to perceive easily which estimations are on. The team expected the user to spend time pressing the buttons to consider multiple combinations.



Figure 5.9: Estimation buttons

5.3 Prototype

This section will describe the prototype realized with Proto.io, that was evaluated before the implementation phase (Chapter 8). This prototype has been modified during the implementation phase and can be found in the Appendix B.

The app starts on the dashboard (Figure 5.10) that displays information about the user's day (circular indicators for calories, expenses and carbon footprint, labels for energy consumption and distance). The estimation buttons are on the bottom of the screen, at the top of the Android navigation bar and then close to the user's fingers. The label "Estimate" was added after user testing activities, as the participants did not understand the meaning of the buttons. When pressing one of those buttons, new values appear on the screen (Figure 5.11) that corresponds to the values estimated by modifying the user's behaviour (cycling or walking instead of using a car), by replacing the actual car with an electric one, or installing a solar panel.

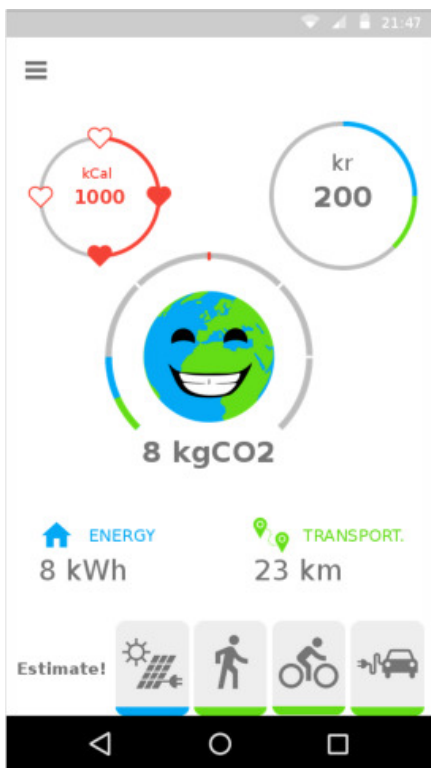

Figure 5.10: Dashboard

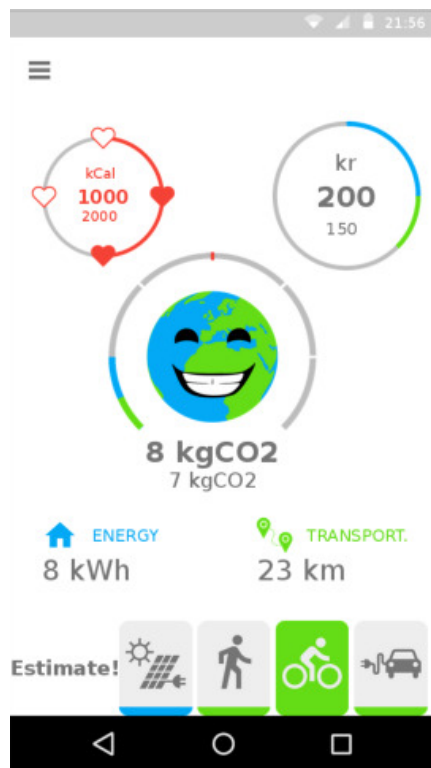

Figure 5.11: Dashboard with cycling estimation

By clicking on a circle, the user can access to a more detailed view about the

indicator (Figure 5.12). The user can change the time scale with a spinner on the top right of the screen. On the weekly (Figure 5.12), monthly (Figure 5.13) or yearly view, the main circular indicator disappears to let only the average value, and let space to the chart representing the evolution of an indicator through the time.



Figure 5.12: Carbon footprint per day Figure 5.13: Carbon footprint per week

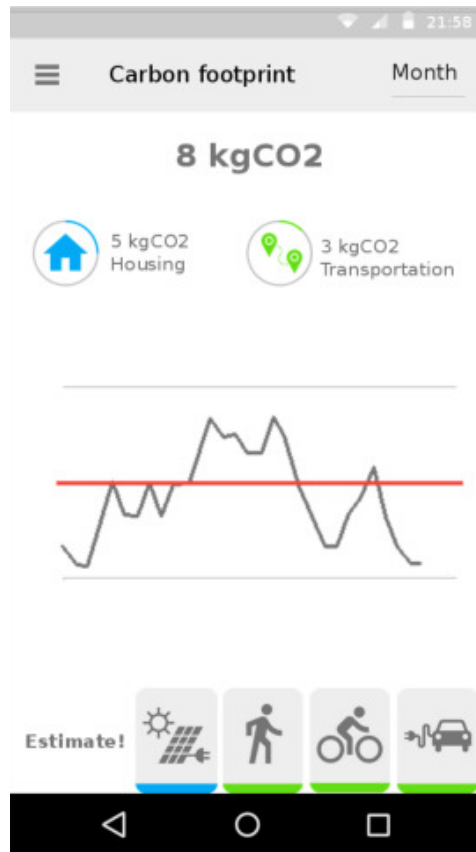

Figure 5.14: Carbon footprint per month

Chapter 6

Technology selection

6.1 Proto.io

Proto.io supports the creation of fully-interactive high-fidelity prototypes, and provides collaboration tools in its full version.

The software has been used for designing the UI.

6.2 Python

Python is a general purpose, interpreted, cross-platform programming language that is object-oriented. It is adapted to web programming and to the treatment of scientific and numeric data.

Python is used for the backend calculations, that are used on the server side.

6.3 Android

This section will justify the choice of developing with the Android SDK according to the project requirements, and describe the development environment in order to help those who want to set up the project or simply develop in Android.

6.3.1 Mobile app: native, hybrid, or web app

Three main approaches exist for developing an app running on a mobile device. The app can be:

- A web app, which is a website adapted for mobile devices and accessible from a web browser.
- A native app is developed with the SDK specific to a mobile operating system, and is installed in the mobile device.

- An hybrid app is built using cross-platform web-technologies, and is also installed in the mobile device.

A web app is usually the quickest one to implement. However, this possibility has been excluded as there is no possibility to use the app offline, that is one of the project's constraints (Section [4.3.3]).

A native app is specific to one platform. Then, if the app requires to work on different mobile operating systems, it has to be implemented separately, that makes the development more expensive and slower than a web or hybrid app. However, native apps offer the best user experience: as they use the languages specific to the platform, the performance is optimal. In addition, the use of native UI components makes the app more intuitive and makes it look better. Native development facilitates also the access to the mobile device features, as the GPS, which is particularly important in the project. Pushing notifications and adding widgets is also easier in a native development.

An hybrid app looks to be a good compromise between a web and a native app. The cross-platform aspect makes the development cheaper and faster than for native apps. The access of the device features is in most of the cases possible, but less reliable. An hybrid approach would avoid the re-implementation of complex components, in the project case, the circular indicators and charts. Usually, hybrid developments use cross-platform languages such as HTML5, CSS3 and JS, which I am more familiar with than Android development.

The final decision was in a meeting when I exposed the pros and cons of hybrid and native development. After discussing with my external supervisors, we decided to prioritize the performance, quality and security over the development cost.

6.3.2 SDK version

When choosing the SDK version, a compromise needs to be done: the latest versions provide a greater API, but are not supported by old devices.

The official website for Android developers[1] provides data about the distribution of devices running on a given version (figure 6.1). As the application does not require complicated features, and aims at targeting as many users as possible, the minimum version supported will be Jelly Bean (API 16).

6.3.3 Android Virtual Device

The Android SDKs provide an Android Virtual Device (AVD) Manager, that allows to test the app on virtual devices with different Android versions, screen sizes and resolutions. To ensure that app works on the target devices, it has been tested in different virtual devices. To cover the minimum configuration, and according to

Version	Codename	API	Distribution
2.3.3 - 2.3.7	Gingerbread	10	1.0%
4.0.3 - 4.0.4	Ice Cream Sandwich	15	1.0%
4.1.x	Jelly Bean	16	3.7%
4.2.x		17	5.4%
4.3		18	1.5%
4.4	KitKat	19	20.8%
5.0	Lollipop	21	9.4%
5.1		22	23.1%
6.0	Marshmallow	23	31.3%
7.0	Nougat	24	2.4%
7.1		25	0.4%

Figure 6.1: Platform Versions - Data collected during a 7-day period ending on March 6, 2017[1]

the screen size and resolution distribution (figure 6.2) most of the tests have been performed on a virtual Nexus S running on the API 16 with a screen size 480x800 and a hdpi.

	ldpi	mdpi	tvdpi	hdpi	xhdpi	xxhdpi	Total
Small	1.1%						1.1%
Normal		2.5%	0.2%	36.1%	33.6%	16.3%	88.7%
Large	0.1%	3.7%	1.8%	0.4%	0.4%		6.4%
Xlarge		2.6%		0.6%	0.6%		3.8%
Total	1.2%	8.8%	2.0%	37.1%	34.6%	16.3%	

Figure 6.2: Screen Sizes and Densities - Data collected during a 7-day period ending on March 6, 2017[1]

Chapter 7

Architecture

This chapter will give an overview of the system, including the mobile app and the server calculations. It will then describe the structure and behaviour of the implemented app.

7.1 System overview

The aim of this section is to describe the components of the project and their connection, and explain how they were used to perform the user experience evaluation.

Figure 7.1 shows an overview of the system. Data related to the user's activity is collected with the mobile device. In the future, we may consider using wearable devices, in order to preserve the mobile phone battery.

This data will be sent to the server, that performs the backend calculations. The server has other inputs: the user's energy consumption, weather data and information about installations. With this data, the server will send information about energy and transportation to the mobile device (energy consumption, total distance, carbon footprint, cost and calories).

In order to be able to use the app offline, the app will store data locally, on the cache memory.

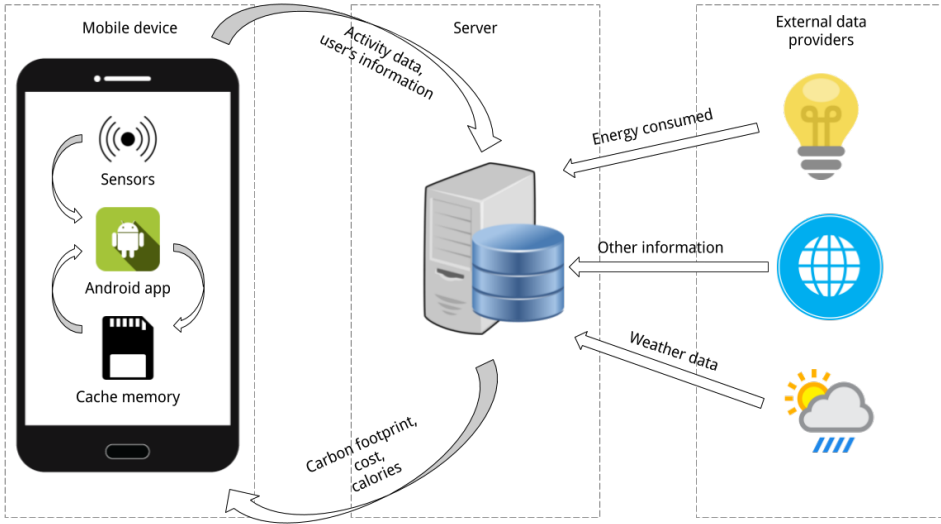

Figure 7.1: System Overview

7.2 Backend calculations

The energy module is the product of the autumn specialization project conducted last semester. It consists of a set of classes and functions in Python to make calculations about the installation of PV systems and batteries for a specific user.

The energy module reads inputs files, navigates on specific websites to collect additional data, and makes calculations.

Inputs

The module requires the following inputs:

- The user's address,
- The user's load profile,
- The energy tariff,
- Weather data.

The module has been tested with sample files, that do not correspond to the same location:

- A random address,
- A sample load profile from NTE,

- A sample electricity price file,
- A sample weather data file from LMT [24].

7.2.1 Communication with Solkart, an external website

In order to collect information about different PV installations, the module can perform an automatic navigation on the website Solkart [40].

Solkart is a website that gives information about possible PV installations for a given address (such as the sizes, prices, and production).

The energy module is able to give inputs to Solkart, navigate to the different screens and collect information about the different PV systems.

7.2.2 Outputs

The energy module is able to generate multiple configurations, with the different PV installations and batteries, and for each of them, calculate the following:

- The net load,
- The infeed,
- The self consumption,
- The equipment price,
- The network, energy and total cost,

The energy module can select the best one for a given criteria (self consumption, total cost). Initially, there were no calculations to obtain the carbon footprint.

7.2.3 Data file generation

The energy module allows to select a relevant PV installation, to calculate the total cost based on one's load profile, and estimate it with a PV installation. It was improved to estimate the CO₂ equivalent of the user's energy expenses.

In addition, the module performs calculations on large data sets, and needs to open physically a browser in order to communicate with external websites (Solkart). Then, it should not run on the user's device, but rather on a server.

Peter improved the module in order to calculate the transportation and energy cost, carbon footprint, and calories. Details about the calculations can be found in the Appendix C. The actual app is running with a data file sample stored in the mobile device, generated by the energy module. An extract of this data file can be found in the Appendix D.

7.3 Software behaviour

7.3.1 Use cases

Figure 7.2 represents the user's interactions with the app. The user can consult the dashboard, make multiple estimations and select an indicator (carbon footprint, calories, or expenses). If an indicator is selected, the user can change the time scale (day, week, or month).

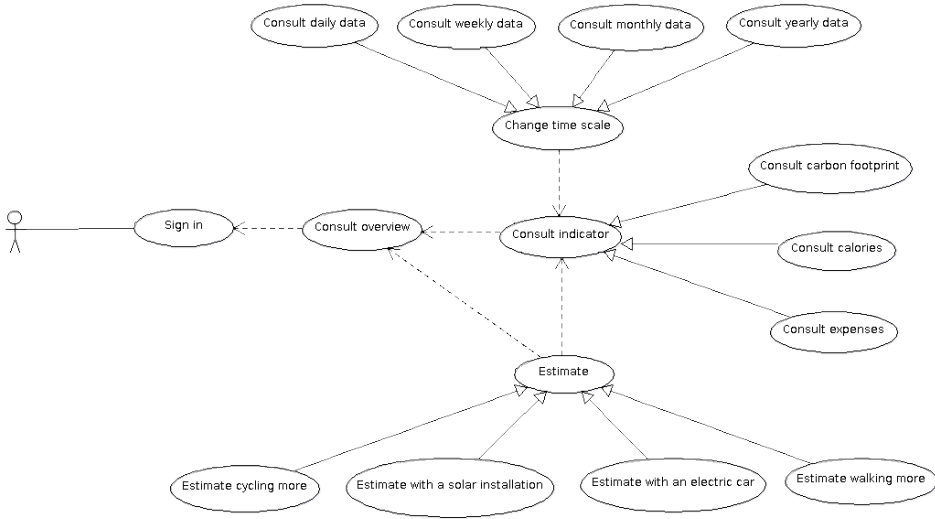

Figure 7.2: Use cases diagram

7.3.2 Single activity - multiple fragments approach

The implementation uses the single activity - multiple fragments approach. It consists on using only one activity in the project, with several fragments. In Android development, a fragment describes the behaviour of a portion of interface.

This approach allows to have better transitions between the different views of the app, in particular when the same components appear on different screens.

It allows also to build flexible UI, as it allows devices with a large screen to display more fragments on the same screen than a smaller one.

7.3.3 Fragments and components description

The following abbreviations will be used in the rest of the section to describe the app fragments and components:

- AB: Action Bar
- TW: Text View
- Ci1: Circle Fragment for Calories
- Ci2: Circle Fragment for Expenses
- Ci3: Circle Fragment for Carbon Footprint
- Ca1: Category Fragment for Housing
- Ca2: Category Fragment for Transportation
- W: Week Fragment
- M: Month Fragment
- EB: Estimation Bar

Action Bar

The Action Bar contains two spinners:

- One for changing the active indicators, or go to the dashboard,
- One for changing the time scale, which is visible only if an indicator is selected.

Circle Fragments

Each circle fragments depends on an indicator (calories, expenses and carbon footprint).

Their appearance changes on each screen. The circle fragments display circle indicators on the dashboard (figure 7.3) and day screen (figure 7.4), and display only a numeric value on the week and month screens (figure 7.5).

The values displayed in the circle fragments depend on the active estimations.

Category Fragments

The category fragments have two aspects. On the main view (figure 7.3) they display the daily energy consumption and the daily distance. On the other screens, they depend on the active indicator (carbon footprint, expenses and calories), and show the distribution between housing and transportation with circular indicators. The values displayed in the category fragments depend on the active estimations.

Week and month Fragments

The week and month fragments are only showed on the week and month screen (figure 7.5). They displayed a graph (a bar chart for the week fragment, and a line chart for the month). The colours of the graph depend on the active indicator. The values of the graph depend on the active estimations.

7.3.4 Screens description

The action and estimation bars appear on every screen, only the central part is changing from one screen to another. The fragments displayed and their states are different from one screen to another.

On the main screen (figure 7.3), the user can select an indicator (calories, expenses or carbon footprint) by clicking on the corresponding circle fragment (Ci1, Ci2 or Ci3), or by using the menu.

The screen is then displayed as on figure 7.4). The circle fragment selected on the dashboard is animated to move physically on the center of the screen, and to extend itself. The category fragments move also on the center, and display information related to the active indicator. A spinner to change the time scale appears on the action bar (AB).

If the selected time scale corresponds to week (resp month), the week (resp month) fragment is displayed, and the circle fragment is reduced (figure 7.5). Using fragments allow to support different screen sizes. Figure 7.6 shows how we could arrange the fragments in the case of a pad.

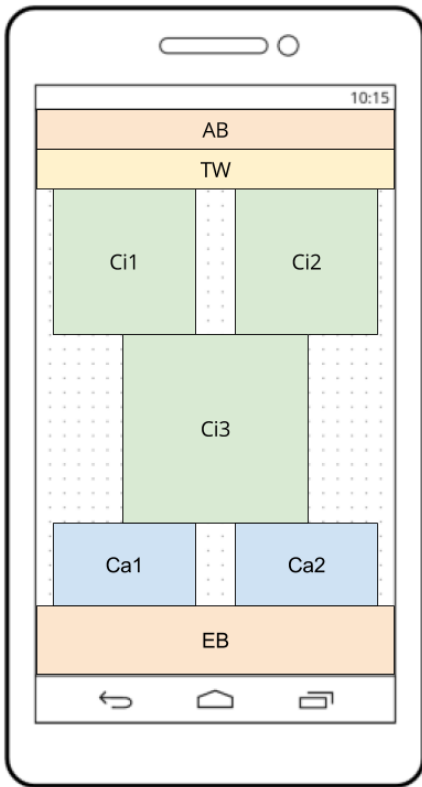

Figure 7.3: Dashboard fragments

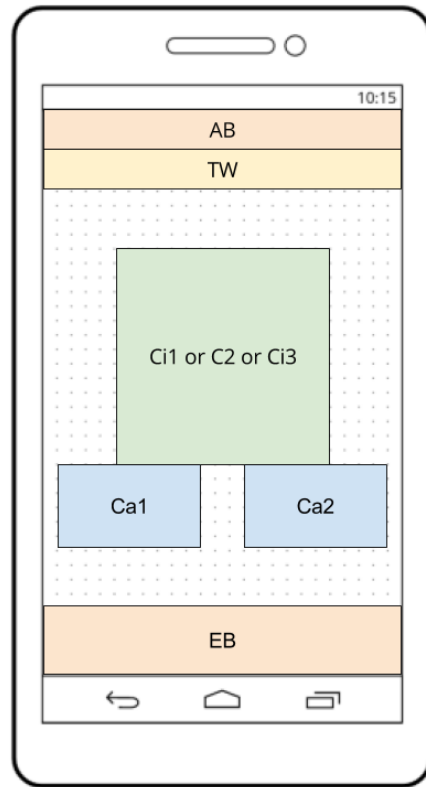

Figure 7.4: Day fragments

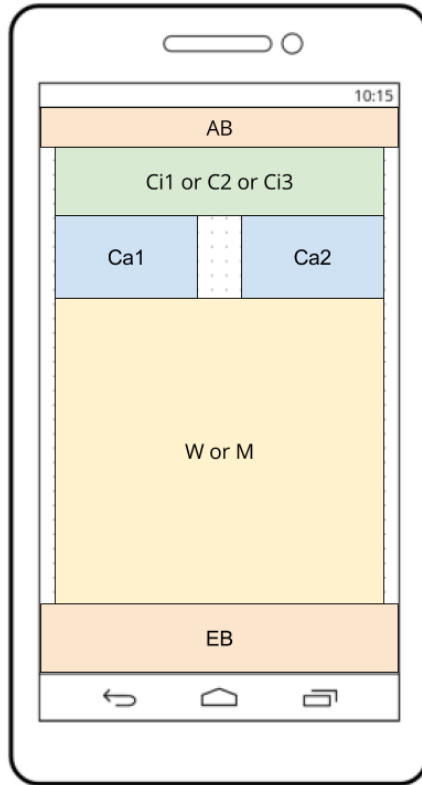

Figure 7.5: Graph fragments

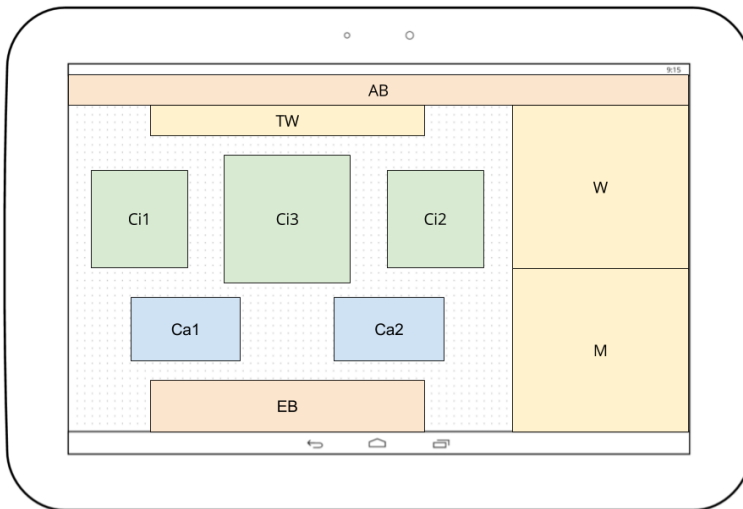

Figure 7.6: Pad fragments

7.4 Software structure

7.4.1 Project files

Android projects in general have a pre-defined structure with code files and resources organized into folders.

The Figure 7.7 shows the structure of the src folder, that contains the Java files. The folder is divided into packages to group the files by their categories:

- com.example.desent.activities contains all the activities
- com.example.desent.fragments contains all the fragments
- com.example.desent.models contains the data models
- com.example.desent.utils provides common utility methods
- com.example.desent.views contains the custom views

The Figure 7.7 shows the structure of the res folders, that contains the XML files and resources. The folder contains the activities and fragments layouts, graphics, data files, and other resources.

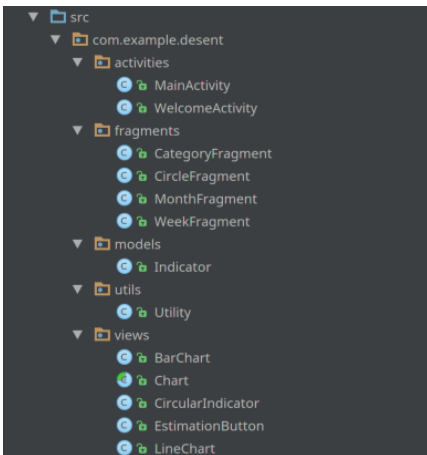

Figure 7.7: Src folder

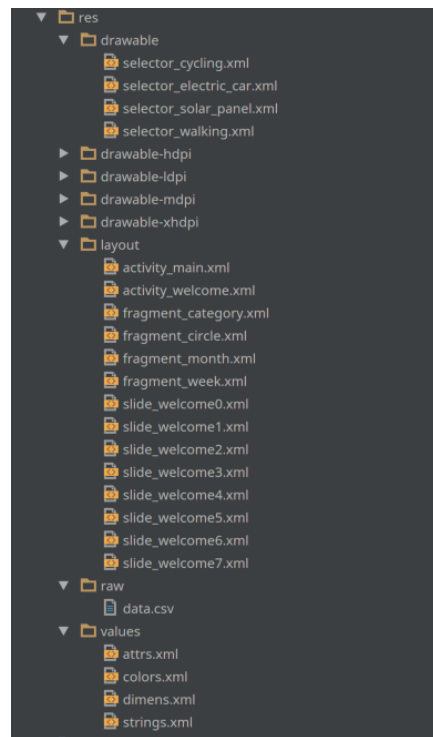

Figure 7.8: Res folder

7.4.2 Class diagram

The diagram in Figure 7.9 shows the relation between all the app components. It has been simplified for a better readability, and shows only the methods that are important for understanding the app mechanisms. The getters, setters, init and update methods do not appear on this diagram.

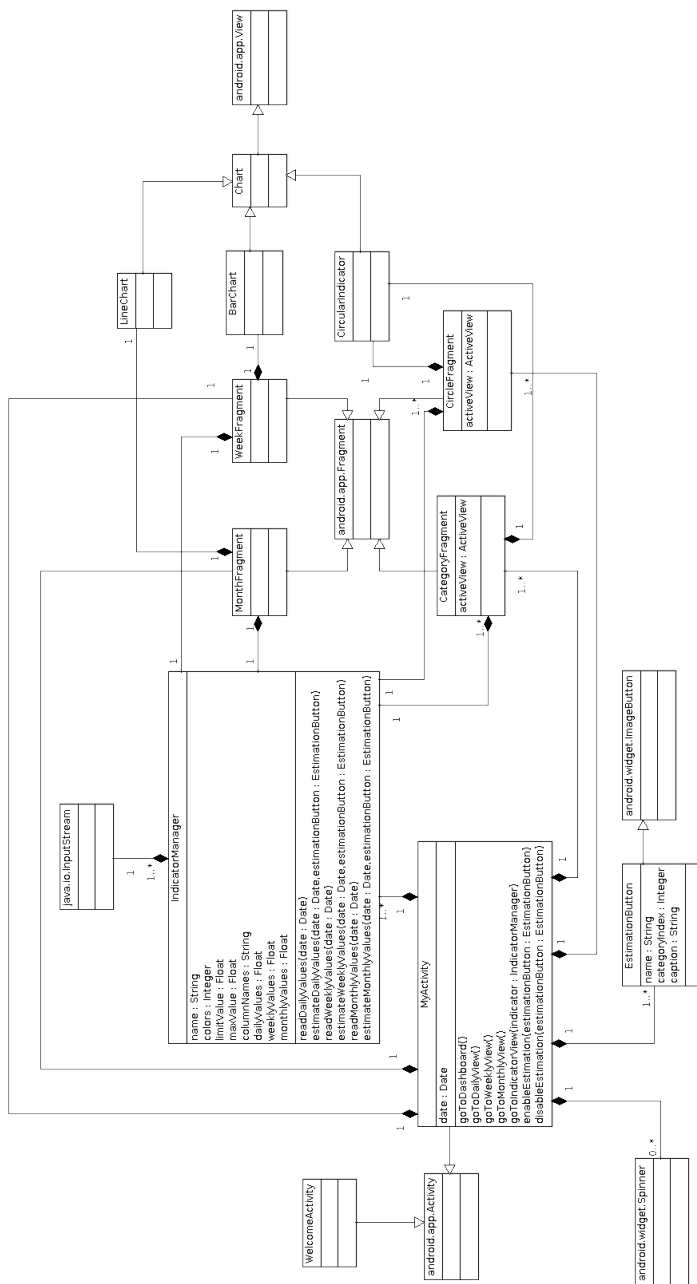

Figure 7.9: Simplified class diagram

Part III

Evaluation

Chapter 8

User Interface Evaluation

This chapter will describe the evaluation of the prototype's UI introduced in Chapter 5. The evaluation was conducted during a workshop with a representative of NTE, called Rikke, considered as an expert.

8.0.1 Questionnaire design

The questionnaire uses a five-point Likert scale, and is based on Jakob Nielsen's 10 general principles for interaction design [32]. More precisely, the evaluation was guided by a research article *Heuristic Evaluation on Mobile Interfaces: A New Checklist* [16].

- Visibility of system status

Q6. The effect of the estimation buttons (on the bottom of the screen) is highly perceptible.

- Match between system and the real world

Q7. The Earth metaphor teaches well the impact of a high carbon footprint (global warming).

Q8. The icons are meaningful.

Q9. The colour code is clear and keep the same meaning in the whole app.

- Recognition rather than recall

Q14. I never had to remember something from other screens to understand the actual one.

- Aesthetic and minimalist design

Q11. The screens do not contain too much information
Q12. The images are well-sized

- Help and documentation

Q10. The screens had all the information I needed to understand them.
Q13. The information is easy to find

8.1 Prototype evaluation: evaluation by an expert

In order to highlight the results, the workshop will not be reported chronologically, but thematically with respect to the points evaluated.

8.1.1 Conduct of the workshop

The workshop started with a quick reminder of the last workshop, and a description of the app concept and the features we agreed on:

- Visualization of personal daily and historical data regarding energy and transportation, and their impact on calories, expenses and carbon footprint
- Estimation of the carbon footprint, calories and expenses with an alternative behaviour or installations
- A daily goal for calories, and a daily restriction on carbon footprint and expenses

Then, screenshots of the prototypes were displayed and explained. The presentation of the prototype was followed by a discussion, when I received feedbacks and asked informally questions from the first and third part of the questionnaire.

At the end of the workshop, Rikke completed the questionnaire, about the heuristic evaluation.

8.1.2 Discussion

Concept evaluation

Overall, Rikke was enthusiastic about the prototype. For her, the prototype was a clear synthesis of the many confusing ideas that appeared during the brainstorming session in autumn. She was surprised to see that almost everything appears on the prototype, but the focus is still there and the prototype looks simple.

Rikke found the carbon footprint particularly interesting and impressive. She is not familiar with the notion of carbon footprint, and according to her, the amount of kgCO₂eq is very powerful and gets attention.

She found the cost motivating. However, she pointed and interesting fact: she would not trust the calculation of the expenses or the impact of a solar panel, because they may not be reliable.

Not many things were said about calories, except that it is relevant in the transportation case.

Regarding the feedbacks on the user data, she mentioned that the user could set-up goals, and have more personalized feedbacks. The energy needs are different from one country to another (partly because of the weather conditions), and she wonders what the limitation for carbon footprint should be in Norway.

According to her, it is interesting to look at transportation data everyday, while energy data is more relevant on the long-term, to have information about its impact.

She was a bit sceptical regarding the estimation part. She liked the transportation part, as it is easier to relate to the everyday life. She saw the point of housing estimations, and found it somehow informative and motivating but liked it less than transportation estimations.

Heuristics evaluation

Rikke liked the layout and found the symbols intuitive and the buttons clear. We discussed about the effect of the buttons, and she suggested two things.

First, she suggested to put the same color for the estimated values and the buttons. It may be more clear, but it would add another color code, in addition to the one to differentiate energy and transportation, and remove it from the buttons.

Secondly, she suggested to replace the current values by the estimations. This solution reduce the amount of information on the screen, and can be then less confusing. However, it requires a bigger effort of memorization from the user, as he/she has to remember the previous values. This solution has to be tested.

Rikke loved the earth. It shows the emergency caused by a high carbon footprint, and shows the effect of the climate change (earth sweating, earth hot). She would have put more dramatic colors when the user has a high carbon footprint.

She first said that she found the colour category consistent. We underlined the fact that it could be confusing, as we use green for transportation, while this colour can be interpreted as a positive thing. We suspect that it could have influenced her when she answered the question related to the colour code.

The amount of information has to be right balanced. Rikke found the app simple, with not a lot text and described it as self explaining. Some more explanation could be added when setting up the app. She suggested to do not introduce more

features. The app contains already a lot of information, even if it looks simple. Rikke said that she was comfortable with the amount of information, but she is not representative of the common user.

General observations

I perceived that Rikke has positive feelings about the app and the concept.

She thinks that it can make people more aware, and help them to take better decisions.

She also pointed the fact that the app is addressed to people enthusiastic about energy.

8.1.3 Results

ID	Question	Note
Q6	The effect of the estimation buttons (on the bottom of the screen) is highly perceptible	4
Q7	The earth metaphors teaches well the impact of a high carbon footprint (global warming)	3
Q8	The icons are meaningful:	
	Solar panel	5
	Walk	5
	Cycle	5
	Electric car	5
	Housing	4
	Transportation	5
Q9	The colour code is clear and keep the same meaning in the whole app	2
Q10	The following screens had all the information I needed to understand them:	
	Dashboard	4
	Carbon footprint - Day	4
	Carbon footprint - Week	5
	Carbon footprint - Month	4
	Carbon footprint - Year	4
Q11	The following screens do not contain too much information:	
	Dashboard	3
	Carbon footprint - Day	4
	Carbon footprint - Week	4
	Carbon footprint - Month	4

	Carbon footprint - Year	4
Q12	The following images are well sized:	
	Dashboard	
	Carbon footprint indicator	4
	Expenses indicator	4
	Calories indicator	4
	Carbon footprint - Day	
	Carbon footprint indicator	5
	Transportation indicator	5
	Housing indicator	5
	Carbon footprint - Week/Month/Year	
	Transportation indicator	5
	Housing indicator	5
	Graph	5
Q13	The following information is easy to find:	
	Daily carbon footprint	4
	Daily expenses	4
	Daily calories burnt	4
	Daily energy consumption	4
	Daily km done	4
	Weekly/monthly/yearly carbon footprint	4
	Distribution of housing/transportation in carbon footprint/expenses	4
	Alternative carbon footprint/expenses/calories burnt by walking/-cycling or using an electric car/solar panel	4

Table 8.1: Heuristics evaluation results

Conclusion

This evaluation was very positive and Rikke showed a lot of enthusiasm about the concept. The discussion and questionnaire showed that according to Rikke, there is no critical issue for this interface.

As the prototype passed the evaluation, the decision has been made to go the next step of the design process and implement the prototype with a view to evaluate the user-experience.

The small changes proposed by Rikke were considered during the implementation phase.

Chapter 9

User Experience Evaluation

This chapter will describe the various testing sessions that were conducted during the implementation phase. Quick testing activities with few targeted users were held during the implementation phase in order to identify and rectify problems responsively. One user testing session was conducted at SINTEF to insure mainly that the app was ready for the final evaluation conducted at NTE.

9.1 Quick findings

This section will summarize quick findings from informal testing sessions that took place along the implementation phase. Those sessions had different contexts, and aimed at gathering feedbacks from targeted users (sometime I included limit cases, with users not comfortable with mobile apps or numbers).

9.1.1 Critical stage of the earth metaphor

The app was tested with a data sample from a fictive user who did not have a sustainable behaviour. At this stage, the carbon footprint limit per day was lower than the final one. As a consequence, the app started with a screen where the earth metaphor was on the most critical stage, with a dead grey planet (Figure 9.1). Every participant's first comment was related to this dead planet. They were surprised, and some of them said it was rude.

The earth allows to give feedbacks on one's behaviour, and changes everyday according to the context. In some cases, the user will start from a "bad" behaviour and improve it using the app. In my opinion, starting a "game" with a sort of "game over screen" is certainly not welcoming and can give a terrible impression.

Furthermore, the use of coercive techniques for conservation behaviour change employing punishment or fear was criticized in literature[47].



Figure 9.1: Starting screen

9.1.2 App interpretation

Overall, users interpreted correctly the numbers and the colour code. Two participants had a first confusion with the colour code and rectified themselves afterwards, with tips. Both reported that the demonstration was too quick, and would have liked to have more time to discover the app quietly.

One of the participants said that she was not comfortable with graphs and apps. She tested the app together with someone who has more knowledge on maths and apps, and felt pressured by the questions related to graphs interpretation. She thinks that she would have not persisted on the mistake by using the app casually, and liked the colours. She suggested me to use a green more close to blue, if I decide to change the colours.

For the second case, I was focusing on the numbers' interpretation and asked the participant to interpret after seeing only the first screen (and not the charts for

week and month). She said that when I asked to interpret the numbers, she was only focused on the planet, and did not read the housing and transportation categories. As she was looking at the planet, her first thought was that the blue was related to water and the green with environment. She suggested to add something that get the user attention on the categories, at least for the first use, or to use different colours than the one on the earth picture. When going on the other screen with only the categories and one circle, she said "now it's obvious".

9.1.3 Navigation

Overall, the participants spent more time on carbon footprint than on expenses or calories. Few users showed enthusiasm for calories. Many participants spent time on the estimation buttons. One expressed that she was trying to see which combinations "make the earth happy". However, all were surprised that the carbon footprint with the cycling estimation was higher than with the electric car estimation. The participants did not read the sentence "Your performance cycling 5km instead of driving" that was displayed when pressing the cycling button.

9.2 Questionnaire design

The complete questionnaire can be found in Appendix A. It consists in three parts:

- A first part to evaluate if the core concepts of the app are clear and have the expected effect,
- A second part evaluating the app's usability,
- A third part to evaluate if the app reach its main goals.

9.2.1 Concept evaluation

The first part of the questionnaire starts with a general question to insure that the app concept is clear.

Q1. I can understand clearly what is the purpose of the app.

This part aims mainly at evaluating the thesis assumptions, namely:

- Health, money and environmental issues are intrinsically motivating

Q2. I found the link between energy, carbon footprint, calories burnt and expenses motivating.

- Providing feedbacks on the user's behaviour increases awareness

Q3. I found the feedbacks on my energy habits useful.
 Q4. I I find useful to have a daily target.
 Q8. I find the visualization of my data through the time useful.

- Feedbacks and goals are motivating

Q5. I find the daily target motivating.
 Q9. I find the visualization of my motivation motivating.

- The attachment to the earth[45].

Q6. I find the earth metaphor engaging.

- The learning function of the earth metaphor[45].

Q7. The earth metaphor represents well the impact of a high carbon footprint.

- Showing an alternative behaviour is motivating.

Q10. I found the estimation functionality motivating.

- The estimation function is enjoyable

Q11. I would spend time pressing the estimation buttons, it's fun!

9.2.2 Usability

The usability was evaluated using questions from SUS[42] (System Usability Scale).

9.2.3 General questions

Some questions aims at evaluating aspects highlighted in a framework for evaluating persuasive and engaging design[4]:

- Overall take-into-use

Q26. I think that I would like to use this app frequently[42].

- Fun and excitement[12][6]

Q19. I enjoyed using the app.

- Perceived value[8]

Q20. I find the app interesting.

- Attractiveness for engaging user experience[12][6]

Q21. I find the app attractive.

- Trustworthiness / system credibility[12][8]

Q22. I would trust the numeric values provided by the app.

- Diffusiveness[9]

Q27. I would consider recommending this app.

During previous user testing sessions, I noticed that some users asked many questions relative to energy or environment. Because of those questions, I wanted to evaluate if this app has the potential to trigger users' curiosity, and lead them to find information by themselves outside the app. So I added the question:

Q24. I feel more curious about energy and environment after using this app.

Finally, the questionnaire aims to evaluate if the app reaches its main goals regarding the COM-B model[30]:

- Awareness

Q23. The app made me more aware of the environment and carbon footprint.

- Motivation and planned behaviour change

Q25. The app will motivate me to change my behaviour to a more sustainable one.

The questionnaire conclude with open-ended questions.

Q20. What did you like most?

Q21. Is there something you would have done differently?

9.3 SINTEF - User testing session

9.3.1 Aim of the session

The main goal of this session was to insure the app reliability, and to fix eventual errors before the final evaluation. In addition, we wanted to evaluate if the app

was self-explanatory, or confused.

I took this opportunity to observe how users react against the app, with minimum information. I focused on the following points:

- Where do users click first?
- Were do they spend time?
- Do they make touchscreen actions that have not the expected result?
- Do they express confusion, enthusiasm?

9.3.2 Conduct of the event

The testing was conducted at SINTEF, with two researchers, external to the project. A quick presentation of the app was made to explain how the data will be collected, and that it is running with data from a fictive user during the last month. No more indication were given during the first phase.

A mobile device with the app running was given to the users and they had to navigate through it. They were asked to speak, and informed that no question would be answered during this first phase.

The second phase was an informal discussion where the users gave feedbacks on the app.



Figure 9.2: App running on a mobile device

9.3.3 Observation

During the tests, both users explored all the features provided by the app. The first comment for both user concerned the earth in the carbon footprint indicator. They read what are the circle indicators are for, but not the information about housing (energy consumption) and transportation (distance), which are secondary information on this main screen. They both spent time with the estimation buttons on the main screen, and did not read the sentence that appears on the top when pressing a button. They explored the indicators by using the menu, and not tapping the circles. They went to the calories view at the end, and did not spent time on it. After the test, the first user went back on the main screen and spent time pressing the estimation buttons.

The main confusion that was expressed was about the estimation with the cycle and the electric car. Both did not understand why the results were better by pressing the electric car than the bicycle. They did not identify the reason during the test. They understood well the color code, and identified that the value on the week and month view corresponded to the daily average (the first user asked the question before identifying it). The second user did not understand if the money represented corresponded to expenses or savings.

9.3.4 Discussion

During the discussion, the users made the following comments:

- They understood the app, but it demanded effort.
- One user said that when she does not understand a component, she taps it to have more details. In this app, it has no effect.
- One user said that if she would be able to personalize her goal, she would spend a lot of time pressing the buttons.
- They did not like the word "performance" on the top of the screen. They would prefer "savings", or a more "marketing" sentence.
- They like the earth.
- They would like to compare with the previous month.
- One user thinks it is a pity that there is no functionality for the bus.
- They would like to see more labels.

One of the user made an interesting remark. She tried to explain why they misunderstood the estimation with the bicycle and the electric car. The walking, cycling and electric car button have the color green (for transportation), and the part of transportation is represented in green on the graphs. So in her mind, when she pushes the walking button, the green part of the carbon footprint indicator (resp expenses) should be due to walking. She suggested to put a different color for everything that is related to activity.

9.3.5 Debriefing and conclusion

This user testing session confirmed that users do not show interest or enthusiasm for calories. It is also the aspect that was less treated during the design and implementation. However, during the discussion, they seemed to be interested about activity. I conclude that this aspect is interesting, but not properly exploited by the app. The comments during the discussion gave some clues to improve this aspect. Peter suggested that instead of housing and transportation, we use the categories "home energy", "driving", and "activity". I think this idea is good, however as the final evaluation is close, it is too risky to review the app model.

This session also showed that the app is not self-explanatory. Peter suggested to use Android toasts for displaying notifications. It can be appropriate, especially during the first uses of the app. We attempted to add more text in the app, but we finally agreed that this text would be cumbersome once users would have learned how to use the app.

Then the app should contain:

- A tutorial mode during the first uses, with textual feedbacks on each user action.
- A user guide for the first utilization.

The user guide is a cheap solution to explain the app, and will be implemented before the final evaluation, to avoid the confusions that appeared during usability tests. The tutorial mode will be implemented on further work.

9.4 NTE - User experience evaluation

9.4.1 Conduct of the event

The event was held at NTE Grildstad, with Sobah, Idar, Peter, and four NTE employees. We had two mobile devices with the app running.

The meeting started with an introduction of the app from Peter. Then, we split the users in two groups, with one mobile phone. They were asked to express their feelings or questions, but were not supposed to get answer. Then, they filled the evaluation questionnaire. The meeting has been concluded with a discussion around the app.

The meeting did not proceed exactly planned. Peter discussed with one of the group during the app testing. They had then more information than the second group. In addition, less time had been dedicated to the final discussion.

I chose then to observe mostly the group with no information, and probably missed valuable feedbacks from the other discussion.

9.4.2 Observations

The first group read the intro slides. Once on the main screen, they pushed directly the earth before reading any information on the screen. They tried to swipe, and nothing happened. Then, they pressed the estimation buttons, analyzed the earth, and read the explanation sentence on the top of the screen. They understood how to switch off the estimation, and understood also the distribution.

At this stage of the navigation, they started discussing about electricity, and solar panel. One of the user asked the other "don't you think this blue category is confusing?".

They navigated on the month, and then on the week. They were confused about the target.

They went back to the dashboard and try to push the housing pictures (in the future, it will display historical data about energy consumption, but has no effect at the moment). They did not understand why "walking was more expensive than using an electric car", and concluded they would use an electric car.

They discussed about the possibility of having a profile with personal information, and consult historical data. They spent a lot of time on the calories indicator. One of the user was very confused with the graphs.

9.4.3 Results

Concept evaluation

ID	Question	U1	U2	U3	U4	Avg
Q1	I understand clearly what is the purpose of the app.	2	3	4	1	2,5
Q2	I find the link between energy, carbon footprint, activity and expenses motivating.	3	2	4	3	3
Q3	I find the feedbacks on my energy habits useful.	2	1	4	3	2,5
Q4	I find useful to have a daily target.	3	2	4	4	3,25
Q5	I find the daily target motivating.	3	2	4	4	3,25
Q6	I find the earth metaphor engaging.	3	2	4	3	3
Q7	The earth metaphor represents well the impact of a high carbon footprint.	2	3	4	2	2,75
Q8	I find the visualization of my data through the time useful.	1	1	4	3	2,25
Q9	I find the visualization of my evolution motivating.	1	2	4	3	2,5

Q10	I find the estimation functionality motivating.	1	2	4	3	2,5
Q11	I would spend time pressing the estimation buttons, it's fun!	3	1	4	3	2,75

Table 9.1: Concept evaluation results

Usability evaluation

ID	Question	U1	U2	U3	U4	Avg
Q12	I find the app unnecessarily complex.	2	0	1	1	1
Q13	I think the app was easy to use.	1	1	1	1	1
Q14	I find the various functions in this app are well integrated.	1	2	1	2	1,5
Q15	I think there are too much inconsistency in this app.	1	0	0	2	0,75
Q16	I would image that most people would learn to use this app very quickly.	1	1	1	0	0,75
Q17	I felt very confused using the app.	0	1	1	1	0,75
Q18	I did not have enough knowledge/skill to use the app.	0	2	4	2	2

Table 9.2: Usability evaluation results

General questions

ID	Question	U1	U2	U3	U4	Avg
Q19	I enjoyed using the app.	2	3	1	3	2,25
Q20	I find the concept interesting.	4	4	4	4	4
Q21	I find the app attractive.	3	2	3	4	3
Q22	I would trust the numeric values provided by the app.	3	2	2	2	2,25
Q23	The app would make me more aware of my own environmental impact.	3	3	3	4	3,25
Q24	I feel more curious about energy and environment after using this app.	2	2	3	4	2,75

Q25	The app would motivate me to change my behaviour to a more sustainable one.	3	3	3	3	3
Q26	I think that I would like to use this app frequently.	3	2	3	3	2,75
Q27	I would consider recommending this app.	2	1	3	3	2,25

Table 9.3: General evaluation results

Q28. What did you like most?

Three persons answered that they liked the concept.

- One precised that he liked monitoring the carbon footprint.
- One precised that she would like to see history about her data, how much she would have saved if she had walked instead of driving.

The other person answered the fact that it is relevant for her daily activity.

Q29. Is there something you would like to be done differently?

- Two users (from the same testing group) answered that they would have eliminated the housing category. One wrote that it was confusing, and the other that she would not trust the numbers this estimation for the solar panel was based on.
- One user would have liked to have a baseline comparison with today's CO₂.
- One would have made something more intuitive, with more explanation.

9.4.4 Analysis

Results

Overall, the results are quite heterogeneous. Many questions have a score from 1 to 4, except regarding the usability where all the results are critical.

The scores of the usability part are lower than expected, but not that surprising. The usability tests during the implementation phase already showed that even if in general people understood the app, there were several sources of confusion in

the app. One of the participants precised that the demonstration was too short to understand the whole app.

In the concept and general part, all the questions have an average note above 2. The questions with the lowest score are the ones related to the app clarity and visualization of data. One of the participants precised that she put a low score because she did not understand it. The question about the utility of energy habits has also a low score. I suspect some of the participants to associate "energy" with the housing part, that include energy consumption and estimations with a solar panel, because they expressed they did not like this category.

All the participants put the maximum score for the question Q20 (I find the concept interesting), that is very encouraging.

In addition, the question about the main goals of the app, that are awareness (Q23) and behaviour change (Q25), have both unanimously a good score (with 3 as minimum).

Data collection

The results of the questionnaire have to be considered carefully, because:

- The number of participants was not significant (4),
- The sample of users did not reflect the whole target users,
- The participants work for NTE.

The participants were extremely critical, and probably more demanding than the general public. The results of the questionnaire and the discussion are then extremely valuable in the sense they are more able to identify the weaknesses of the app.

However, they had many expectations concerning the features of the app. They were expecting the app to be customizable and to have a social aspect. Those aspects are treated in the app requirements, but were deliberately not treated in the design and implementation in this master thesis.

We should have explained our plans in term of future work during the app presentation, in particular regarding the missing features that we have planned to develop. For example, it is obvious for us that the app will have settings, but someone mentioned that this aspect was missing in Q29. Being more clear about those aspects would have avoid misunderstandings, and allowed feedbacks more interesting for us. In any case, those feedbacks will be very useful when prioritizing further work.

Usability

The results of the questionnaire were extremely bad in the usability part. It is clear that some aspects of the app are confusing, and we have to work more to make the app more user friendly.

But the app, as it is, is not a final product. During the demonstration, some users were trying to swipe or push the categories. I deliberately chose to not implement effects when swiping, to be able to add features more easily in the future. The visualization of transportation and energy data is not yet available. I think this contributed to make the navigation very disturbing.

I also think that the participants were frustrated to not see some features (account settings, social media aspect). The fact that the data collection (tracking movement) is not yet available makes the app even more difficult to understand. One of the participants told us, before testing the app, "I like competition", then the app did not meet his expectations. In this sense, maybe the participants put low score to show that in general, they disagree on the way the app was designed.

Electricity aspect

NTE suggested to remove the aspect regarding home energy (energy consumption, estimation with solar panel). The participants found this aspect particularly confusing. None of the users who had tested the app raised this issue before.

In fact, the argument of carbon footprint for promoting solar installations is not that relevant in Norway because the emissions due to the electricity production is very low compared to the other European countries[10]. However, if this argument is not that relevant in Norway, DESENT is a European project with collaborators in Austria and in the Netherlands. There, the installation of solar panel can be more benefit in term of carbon footprint savings.

In addition, NTE is also working on a project, Mitt Energihjem[31], that aims at increasing awareness about one's energy consumption.

Conclusion

The participants showed a lot of enthusiasm about the app concept. This is really encouraging because the idea of showing that kind of very scientific data to the general public is challenging.

However, the app has a lot of content, that makes difficult to have a simple and clear product. The app as it is presents problems in term of usability and has to be improved to be more intuitive and more user-friendly.

To conclude, it would be interesting to make an evaluation on a larger sample of users, who have no relation with the project, in order to get more valid results.

Chapter 10

Discussion

10.1 Design choices

10.1.1 Cognitive dissonance[22]

The app has been tested with sample data from a fictive user, who was driving around 40km per day. The electric car button estimates the user's values if he/she replaces his/her current car by an electric car. The walking or cycling buttons estimates the user's values if he/she walks or cycles 5km more instead of driving.

This rule has been decided lately, during the implementation process, in order to not ask users to cycle or walk a distance that is not affordable. It aims to help the user to take better decisions according to his/her personal needs. When somebody needs to travel long distances everyday, it is not reasonable to suggest him/her to substitute his/her car by a bicycle. An electric car represents a good compromise to achieve a lower carbon footprint.

Every person who has tested the app asked the question: "why the electric car is better than the bicycle?". Some of them expressed that the app was wrong. This should be because for the same distance, the bicycle is more economic and eco-friendly than the electric car.

The same phenomena appeared for calories, some users were surprised that the "bicycle burnt less calories than walking", because cycling is more exhausting than walking, for the same amount of time. In fact, for the same distance, cycling burns in average less calories than walking.

Those confusions are dangerous for the app, as users may not trust it.

10.1.2 Calories

In the user interface, we chose to use calories to encourage people to be more active. In fact, calories are an easy way to quantify activity, and we assumed that the notion of calories is familiar to people and motivating.

During user testing sessions, I observed that it was generally the last aspect explored by the user. Some of them expressed repulsion when seeing calories.

In fact, calories can have a bad connotation: the calories model is quite contested, and calories are usually a marketing argument for people who attempts to lose weight. Then, it may irritate some users, or discredit the app by using a model that is not truthful.

Maybe the minutes of activity per day would have been a better indicator of activity for this app.

10.2 Methods

10.2.1 Prototyping

During the design phase, co-design sessions with Peter had been planned incrementally. Those sessions allowed to elicit requirements that did not appear during the brainstorming sessions. In addition, they allowed to produce a user interface that satisfied Peter.

However, they were time-consuming. After the first paper prototype, we agreed on working on Proto.io. Then, we designed many components that did not appear on the final UI. Optimally, we should have spent more time on the paper prototype, until it was satisfactory. However, we changed our mind many time, or had new ideas during the prototyping phase. Furthermore, we did not agree on the time spent on the UI design, so this phase has been long.

Another thing I noticed during the evaluation of the user interface testings is that the participants focused more on the aspect of the app, they liked the picture, the colours, and gave only few feedbacks about the content, or raised few usability problems. Wong[46] observed that using low-fidelity prototype and sketches avoids the discussions on the graphics and gives better results to identify usability problems.

10.2.2 Evaluations

During the semester, two main evaluations had been planned: one for evaluating the UI, and one for evaluating the UX.

Those evaluations have been performed with NTE employees. To product more

consistent quantitative data from the questionnaire, it would have been more appropriate to plan an evaluation with a larger sample of potential users. However, it allowed the production of very valuable qualitative data, from discussions and observations.

In addition, there is a difference between the results of the UI and UX evaluations regarding usability. The aspect of both prototypes were similar, the main difference was that the UI evaluation was on a demonstration of screenshots, when the UX evaluation was on an interactive prototype. The UI evaluation has been planned in order to adjust the UI afterwards. The results of this evaluation have been very positive, even for the usability heuristics. Unfortunately, the user interface evaluation did then not allow to detect the usability issues raised during the user experience evaluation.

Chapter 11

Conclusion and further work

11.1 Conclusion

The several experiences with potential users have been very encouraging. They have been very enthusiastic about the app concept, asked many questions and some of them are looking forward to testing the app again once integrated and with their own data.

The main drawback is that the app attempts to bring a huge amount of information, and let sometime the user confused. A lack of intuitiveness has been highlighted during several tests.

The questionnaire and observations have shown that the app has a good chance to lead to a behaviour change. In addition, the app has a potential to increase awareness and trigger interest. This could make the behaviour change durable, which could not have been the case with the only use of incentives.

11.2 Further work

The evaluations have shown that many users found the app too confusing. They requested the app to be "more textual". The team should consider adding a "tutorial mode" with explanation of each user's action.

During the test sessions, some users raised that the demonstration was too short, and they would have liked to have more time to discover the app. In addition, an evaluation with more users (whose profile corresponds to the target users) should be performed in order to collect more significant quantitative results, especially regarding the app usability.

In addition, some users were confused by testing a prototype with not all the features, particularly without the user's profile and setting, and with dummy data.

The fact that the app is giving feedbacks on the user's own data is the strength of the app. A testing period to evaluate how users react with their own data (even with transportation only) and if a behaviour change is observed should be planned.

In order to integrate the app with the minimum requirements, the following has to be done:

- Find a server to run the calculations,
- Develop the authentication,
- Design the data storage.

Then, some new features should be considered, as a priority:

- The customization of goals,
- The planning of long-term objectives,
- The customization of the user's profile to have more accurate calculations,
- Social media aspects

To conclude, some of the app elements could be redesigned. For example the savings could be used to show how the user can achieve large investments (solar panel, electric car) with small changes every day. Then, the savings could be perceived more as a reward than only not information. More generally, the app could use more incentives or take better advantage of the benefits of pro-environmental lifestyle changes.

Bibliography

- [1] *Android Developers*. <https://developer.android.com/index.html>.
- [2] *BeAware*. <http://www.energyawareness.eu/beaware/>.
- [3] N. Castell et al. “Supporting Sustainable Mobility Using Mobile Technologies and Personalized Environmental Information: The Citi-Sense-MOB Approach in Oslo, Norway”. In: *Advances and New Trends in Environmental and Energy Informatics*. 2016, pp. 199–218.
- [4] T. R. Chang, E. Kaasinen, and K. Kaipainen. “What Influences Users’ Decisions to Take Apps into Use? A Framework for Evaluating Persuasive and Engaging Design in Mobile Apps for Well-Being”. In: *Visual Representations and Reasoning*. 2010, pp. 20–25.
- [5] A. Clarke and R. Steele. “How Personal Fitness Data Can be Re-used by Smart Cities”. In: *Intelligent Sensors, Sensor Networks and Information Processing (ISSNIP), 2011 Seventh International Conference on*. IEEE. 2011, pp. 395–400.
- [6] D. Norman. “Emotion design: attractive things work better”. In: *interactions* 9.4 (2002), pp. 36–42.
- [7] T. Dillahunt et al. “Motivating environmentally sustainable behavior changes with a virtual polar bear”. In: *Pervasive 2008 Workshop Proceedings*. Vol. 8. 2008, pp. 58–62.
- [8] E. Kaasinen. “User acceptance of location-aware mobile guides based on seven field studies”. In: *Behaviour & Information Technology* 24.1 (2005), pp. 37–49.
- [9] E. Rogers. *Diffusion of innovations*. 2010.
- [10] *Electricity map*. <https://www.electricitymap.org/>.
- [11] B. J. Fogg. “Persuasive Technology: Using Computers to Change What We Think and Do”. In: *Ubiquity* 2002.December (2002).
- [12] B.J. Fogg. “Persuasive Technology: Using Computers to Change What We Think and Do”. In: *Ubiquity* 2002.December (2002), p. 5.
- [13] T. Fritz et al. “Persuasive Technology in the Real World: A Study of Long-Term Use of Activity Sensing Devices for Fitness”. In:

- [14] *Global Greenhouse Gas Emissions Data*. <https://www.epa.gov/ghgemissions/global-greenhouse-gas-emissions-data#Sector>.
- [15] P. Gremaud. “Pervasive, Persuasive Gaming for Energy Conservation”. In: *PAI MSc Seminar Report–Spring*. 2013.
- [16] R. Y. Gómez, D. C. Caballero, and J.L. Sevillano. *Heuristic Evaluation on Mobile Interfaces: A New Checklist*. <https://www.hindawi.com/journals/tswj/2014/434326/>.
- [17] H. A. He, S. Greenberg, and E. M. Huang. “One Size Does Not Fit All: Applying the Transtheoretical Model to Energy Feedback Technology Design”. In: *Proceedings of the SIGCHI Conference on Human Factors in Computing Systems*. ACM. 2010, pp. 927–936.
- [18] K. Huotari and J. Hamari. “Defining Gamification: A Service Marketing Perspective”. In: *Proceeding of the 16th International Academic MindTrek Conference*. ACM. 2012, pp. 17–22.
- [19] J. O. Prochaska. “Transtheoretical Model of Behavior Change”. In: *Encyclopedia of behavioral medicine*. 2013, pp. 1997–2000.
- [20] G. Jacucci et al. “Designing Effective Feedback of Electricity Consumption for Mobile User Interfaces”. In: *PsychNology Journal* 7.3 (2009).
- [21] K. M. Kapp. *The Gamification of Learning and Instruction*. 2012.
- [22] L. A. Festinger. *A theory of cognitive dissonance*. 1962.
- [23] M. R. Lepper. “Motivational Considerations in the Study of Instruction”. In: *Cognition and Instruction* 5.4 (1988), pp. 289–309.
- [24] *LMT*. <http://lmt.bioforsk.no/>.
- [25] E. A. Locke. “Goal Theory vs. Control Theory: Contrasting Approaches to Understanding Work Motivation”. In: *Motivation and Emotion* 15.1 (1991), pp. 9–28.
- [26] D. Lockton and N. Harrison D. Stanton. “Making the user more efficient: design for sustainable behaviour”. In: *International journal of sustainable engineering* 1.1 (2008), pp. 3–8.
- [27] J. Maitland et al. “Increasing the Awareness of Daily Activity Levels with Pervasive Computing”. In: *2006 Pervasive Health Conference and Workshops*. 2006, pp. 1–9.
- [28] T. W. Malone. “Toward a Theory of Intrinsically Motivating Instruction*”. In: *Cognitive Science* 5.4 (1981).
- [29] L.T. McCalley and C. J. H. Midden. “Energy conservation through product-integrated feedback: The roles of goal-setting and social orientation”. In: *Journal of economic psychology* 23.5 (2002), pp. 589–603.
- [30] S. Michie, L. Atkins, and R. West. *The Behaviour Change Wheel: A Guide to Designing Interventions*. 2014.
- [31] *Mitt Energihjem*. <http://www.nteinnovasjon.no/prosjekter/mitt-energihjem>.

- [32] J. Nielsen. *10 Usability Heuristics for User Interface Design*. <https://www.nngroup.com/articles/ten-usability-heuristics/>.
- [33] B. J. Oates. *Researching information systems and computing*. 2006.
- [34] World Health Organization. *Global recommendations on physical activity for health*.
- [35] F. Paetsch, A. Eberlein, and F. Maurer. “Requirements engineering and agile software development”. In: *WET ICE 2003. Proceedings. Twelfth IEEE International Workshops on Enabling Technologies: Infrastructure for Collaborative Enterprises, 2003*. 2003, pp. 308–313.
- [36] R. M. Ryan and E. L. Deci. “Intrinsic and Extrinsic Motivations: Classic Definitions and New Directions”. In: *Contemporary Educational Psychology* 25.1 (2000), pp. 54–67.
- [37] P. W. Schultz et al. “The Constructive, Destructive, and Reconstructive Power of Social Norms”. In: *Psychological science* 18.5 (2007), pp. 429–434.
- [38] C. Seligman and J. M. Darley. “Feedback as a Means of Decreasing Residential Energy Consumption”. In: *Journal of Applied Psychology* 62.4 (1977), p. 363.
- [39] F. W. Siero et al. “Changing organizational energy consumption behaviour through comparative feedback”. In: *Journal of environmental psychology* 16.3 (1996), pp. 235–246.
- [40] *Solkart*. <https://solkart.no/>.
- [41] Statistics Norway. *Survey of consumer expenditure, 2012*. <https://www.ssb.no/en/inntekt-og-forbruk/statistikker/fbu>.
- [42] *System Usability Scale*. <https://www.usability.gov/how-to-and-tools/methods/system-usability-scale.html>.
- [43] E. Tolia et al. “IdleWars: an Evaluation of a Pervasive Game to Promote Sustainable Behaviour in the Workplace”. In: *International Conference on Entertainment Computing*. 2015, pp. 224–237.
- [44] J.T. Van Houwelingen and W.F. Van Raaij. “The effect of goal setting and daily electronic feedback on in-home energy use”. In: *Journal of consumer research* 16.1 (1989), pp. 98–105.
- [45] Jane Yung-jen Hsu Wen-Chieh Fang. *Design Concerns of Persuasive Feedback System*.
- [46] Y. Y. Wong. “Rough and Ready Prototypes: Lessons from Graphic Design”. In: *Posters and Short Talks of the 1992 SIGCHI Conference on Human Factors in Computing Systems*. CHI '92. Monterey, California, 1992, pp. 83–84.
- [47] R. D. Young. “Changing Behavior and Making it Stick”. In: *Environment and Behavior* 25.3 (1993), pp. 485–505.
- [48] D. Zowghi and C. Coulin. “Requirements Elicitation: A Survey of Techniques, Approaches, and Tools”. In: *Engineering and Managing Software Requirements*. Berlin, Heidelberg: Springer Berlin Heidelberg, 2005, pp. 19–46.

Appendices

Appendix A

Questionnaires

DESENT - Prototype Evaluation

	Strongly agree	Agree	Neutral	Disagree	Strongly disagree
Q6. The effect of the estimation buttons (on the bottom of the screen) is highly perceptible.					
Q7. The earth metaphors teaches well the impact of a high carbon footprint (global warming).					
Q8. The icons are meaningful:					
• Solar panel					
• Walk					
• Bike					
• Electric car					
• Housing					
• Transportation					
Q9. The colour code is clear and keep the same meaning in the whole app.					
Q10. The following screens had all the information I needed to understand them:					
• Dashboard					
• Carbon footprint - Day					
• Carbon footprint - Week					
• Carbon footprint - Month					
• Carbon footprint - Year					
Q11. The following screens do not contain too much information:					
• Dashboard					
• Carbon footprint - Day					
• Carbon footprint - Week					

● Carbon footprint - Month					
● Carbon footprint - Year					
Q12. The following images are well sized:					
● Dashboard					
○ Carbon footprint indicator					
○ Expenses indicators					
○ Calories indicator					
● Carbon footprint - Day					
○ Carbon footprint indicator					
○ Transportation indicator					
○ Housing indicator					
● Carbon footprint - Week / Month / Year					
○ Transportation indicator					
○ Housing indicator					
○ Graph					
Q13. The following information is easy to find:					
● Daily carbon footprint					
● Daily expenses					
● Daily calories burnt					
● Daily energy consumption					
● Daily km done					
● Weekly / monthly / yearly carbon footprint					
● Repartition of housing / transportation in carbon footprint/expenses					

<ul style="list-style-type: none">Alternative carbon footprint / expenses / calories burnt by walking / cycling or using an electric car / solar panel					
----------------------------------------------------------------------------------------------------------------------------------------------------------------------	--	--	--	--	--

Thank you for your time!

DESENT evaluation

Concept evaluation

	Strongly agree	Agree	Neutral	Disagree	Strongly disagree
Q1. I understand clearly what is the purpose of the app.					
Q2. I find the link between energy, carbon footprint, activity and expenses motivating.					
Q3. I find the feedbacks on my energy habits useful.					
Q4. I find useful to have a daily target.					
Q5 I find the daily target motivating.					
Q6. I find the earth metaphor engaging.					
Q7. The earth metaphors represents well the impact of a high carbon footprint.					
Q8. I find the visualization of my data through the time useful.					
Q9. I find the visualization of my evolution motivating.					
Q10. I find the estimation functionality motivating.					
Q11. I would spend time pressing the estimation buttons, it's fun!					

Usability evaluation

	Strongly agree	Agree	Neutral	Disagree	Strongly disagree
Q12. I find the app unnecessarily complex.					
Q13. I think the app was easy to use.					
Q14. I find the various functions in this app are well integrated.					
Q15. I think there are too much inconsistency in this app.					
Q16. I would imagine that most people would learn to use this app very quickly.					
Q17. I felt very confused using the app.					
Q18. I did not have enough knowledge/skill to use the app.					

General questions

	Strongly agree	Agree	Neutral	Disagree	Strongly disagree
Q19. I enjoyed using the app.					
Q20. I find the concept interesting.					
Q21. I find the app attractive.					
Q22. I would trust the numeric values provided by the app.					
Q23. The app would make me more aware of my own environmental impact.					
Q24. I feel more curious about energy and environment after using this app.					
Q25. The app would motivate me to change my behaviour to a more sustainable one.					
Q26. I think that I would like to use this app frequently.					
Q27. I would consider recommending this app.					

Q28. What did you like most?

Q29. Is there something you would like to be done differently?

Thank you for your time!

Appendix B

Screenshots

B.1 Tutorial slides

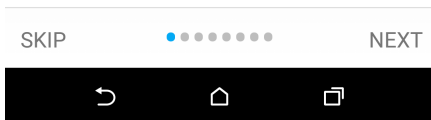
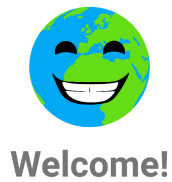

This app accesses to your electricity profile and follows your travels to analyze your performances.

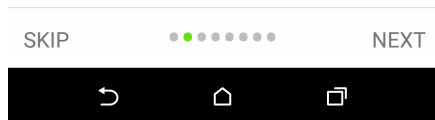

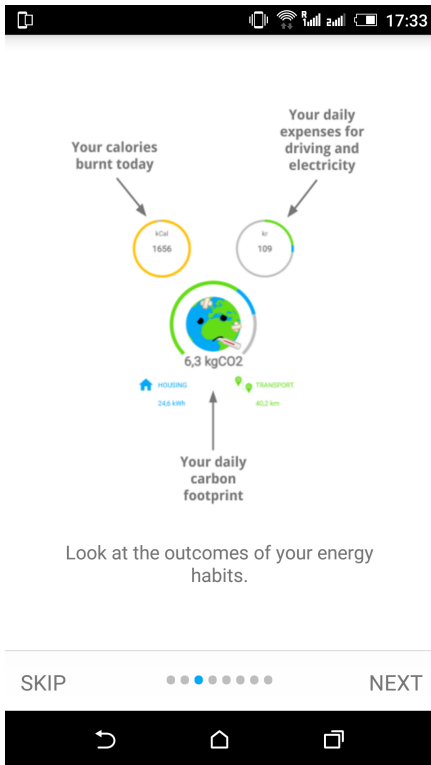

Look at the outcomes of your energy habits.



Estimate your savings with more sustainable technologies...

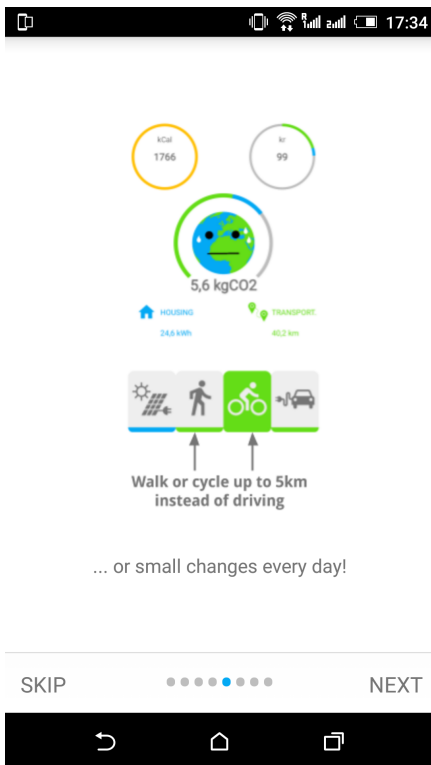

... or small changes every day!

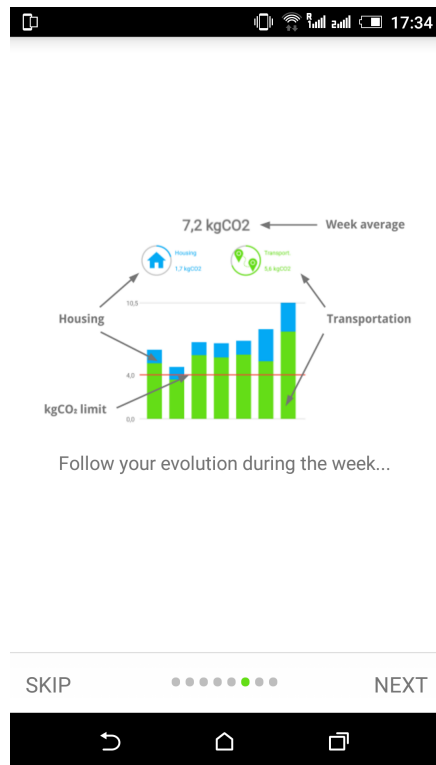

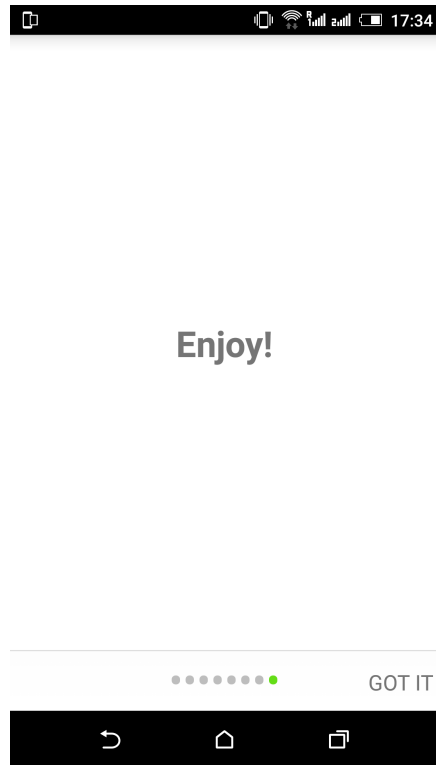

B.2 App

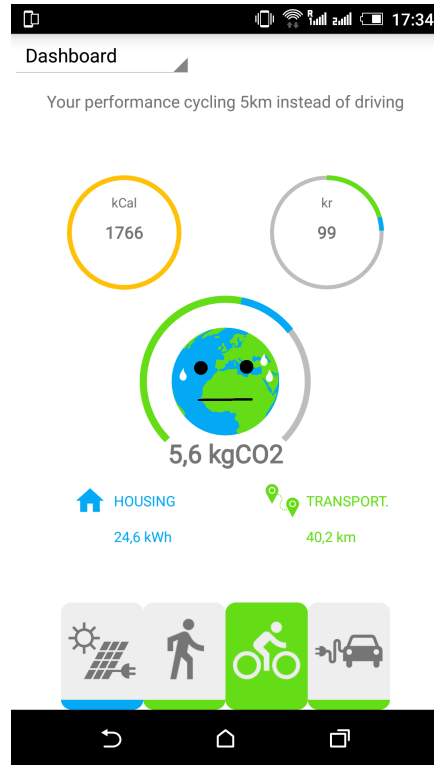
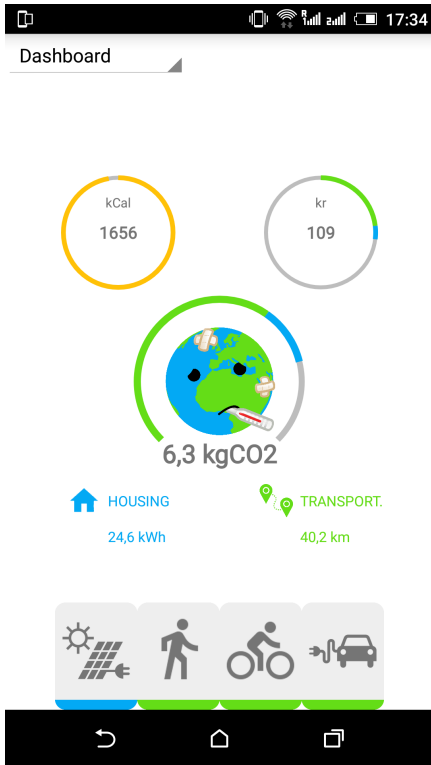

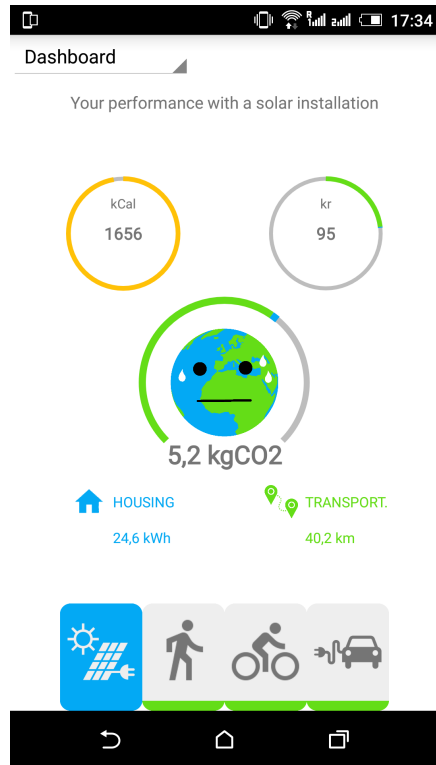
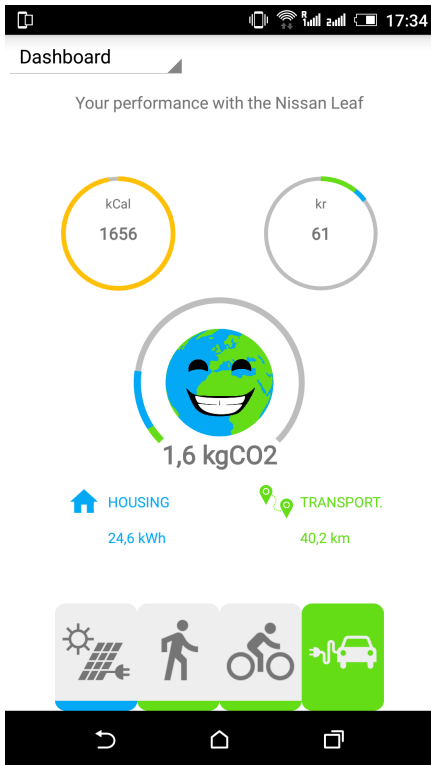

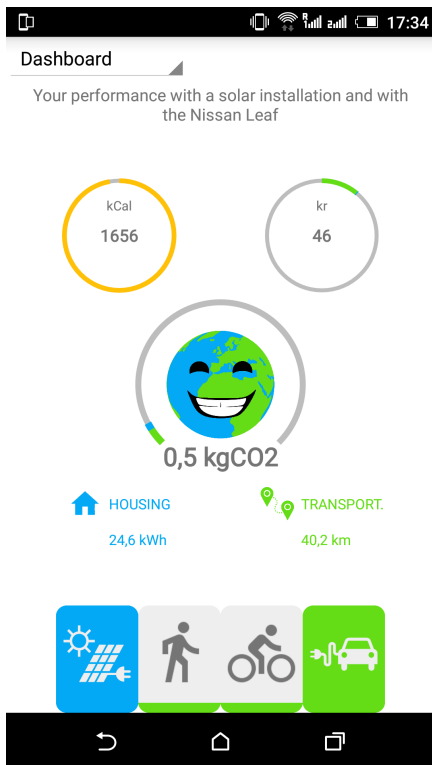

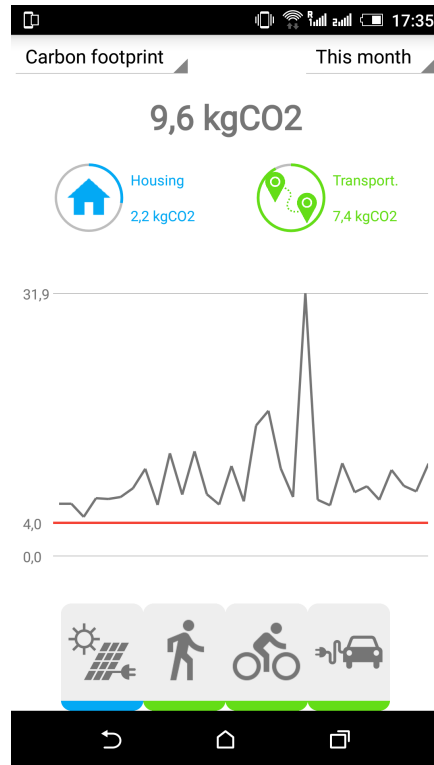
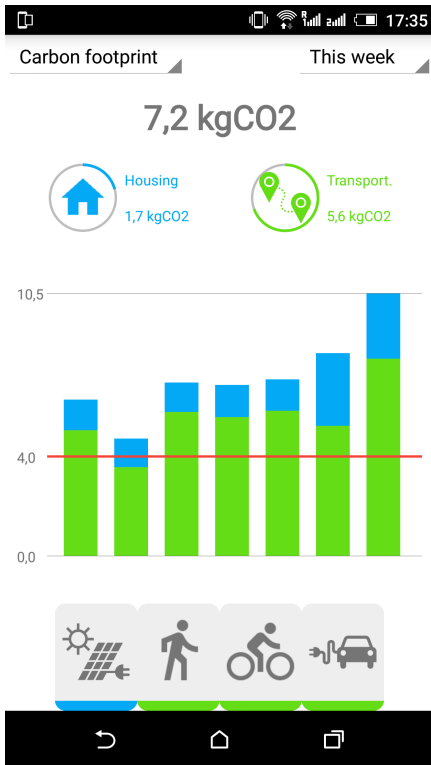

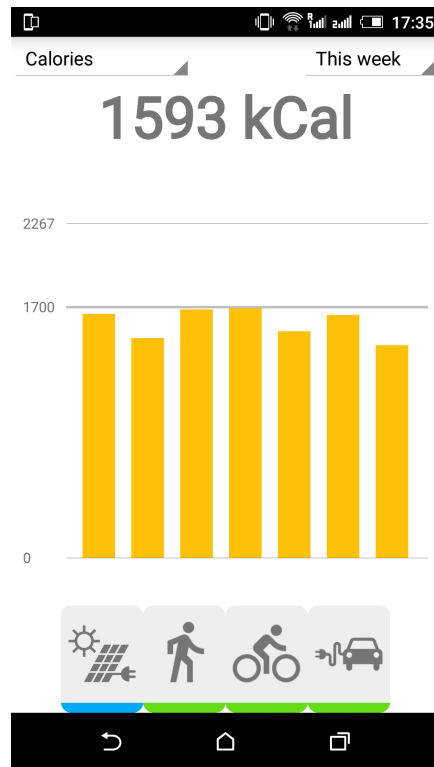
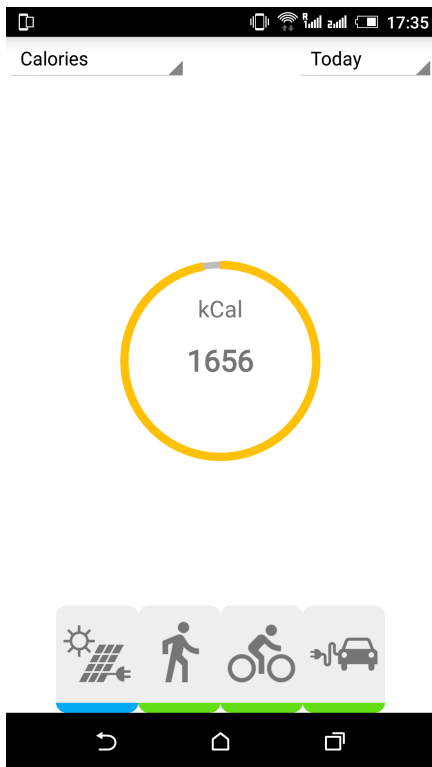

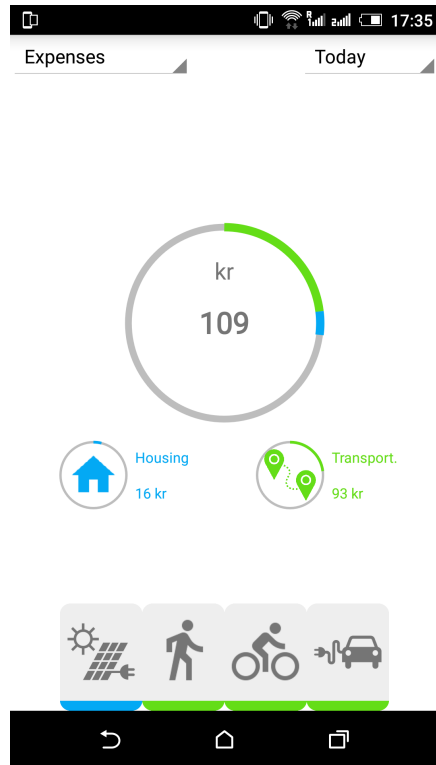
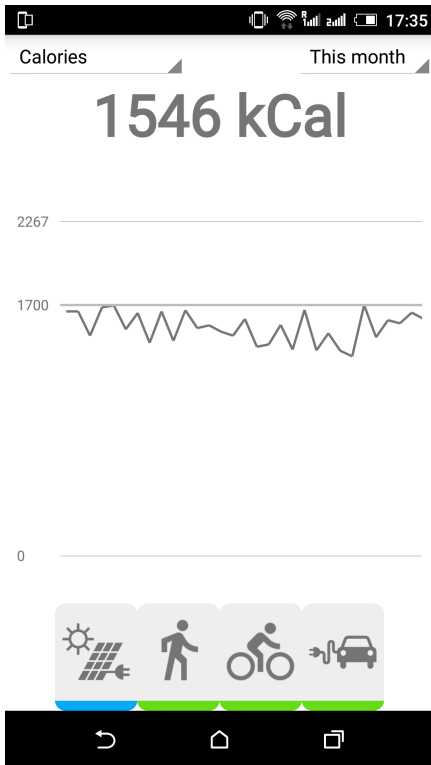

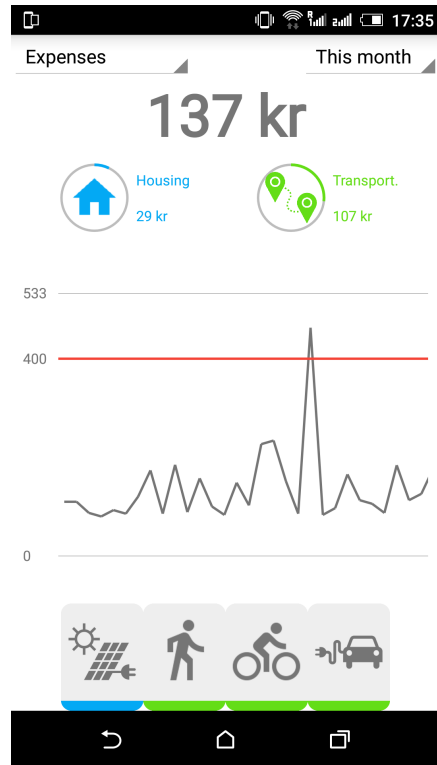
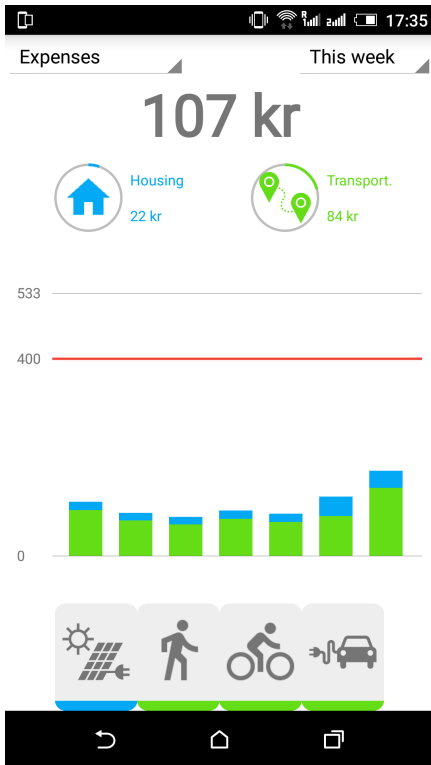

Appendix C

Calculations

The following document has been written by Peter Ahcin. It describes the calculations used in the app.

C.1 Cost of solar power

The app tries to visualize the impact of investing into a solar installation in an immediate way. All consumption costs and the costs of the user's solar installation are translated into hourly values. Energy consumed is paid for very directly. The electricity company charges the consumer for each kWh of used electricity and the use of the electricity grid (nettleie in Norway), which can be divided generally into fixed charges for billing and with bigger customers for peak load, and per kWh. In Norway, the future trend is toward charging a larger fixed part and a smaller variable per kWh part, since this corresponds better to the actual cost of the distribution system operator. Namely, network costs are predominantly infrastructural costs that depend not on the amount of energy transported but rather on the capacity of the network to support the highest – peak loads that may occur only a few hours in a year.

The cost of energy generated by the solar installation is calculated as the so called Levelised Cost of Electricity generation (LCOE):

$$LCOE = \frac{\sum_{t=1}^n \frac{I_t + M_t + F_t}{(1+r)^t}}{\sum_{t=1}^n \frac{E_t}{(1+r)^t}} \quad (C.1)$$

Where:

- LCOE – lifetime levelised cost of electricity generation;
- I_t – investment expenditures in the year t ;
- M_t - operations and maintenance expenditures in the year t ;

- F_t - fuel expenditures in the year t ;
- E_t - electricity generation in the year t ;
- r - discount rate
- n - economic life of the system.

The above is taken from:

· IRENA: "Solar Photovoltaics" Renewable energy technologies: Cost analysis series, Volume 1: Power Sector Issue 4/5, June 2012.

We take the economic lifetime to be 30 years and a discount rate of 8% which corresponds to the cost of capital for renewable energy projects Europe. The values are calculated with the NREL LCOE calculator¹ and neglect the performance degradation factor. However, due to the high discount factor, this has little effect on the obtained value of LCOE.

C.2 Cost of driving

The cost of driving is estimated using the web service Bilkostnads kalkulator that's available at:

<http://www.smartepenger.no/kalkulatorer/2164-beregn-arlige-bilkostnader-for-brukt>

The key inputs are:

- current value of the vehicle
- age of the vehicle
- distance on the kilometer counter
- number of years the user will keep the vehicle
- distance driven per year
- fuel consumption per Norwegian mile

The calculator produces a daily cost of the vehicle that includes all variable and fixed costs and an estimate of the marginal cost of every additional kilometer driven. The daily value is divided into an hourly value for the app to which the marginal cost is added for the distance driven every hour.

¹http://www.nrel.gov/analysis/tech_lcoe.html

C.3 Emissions from electricity consumption

The emissions factor for electricity consumption is taken from a SINTEF study². The author's put the value at 157 gCO₂e/kWh. Both consumption and the production of the solar installation use this same factor, with the production obviously having a negative value of -157 gCO₂e/kWh.

C.4 Emissions from driving

Greenhouse gas emissions from driving are calculated from the estimated fuel consumption. For gasoline vehicles the value 2392 gCO₂e/L is used. For diesel vehicles it is 2640 gCO₂e/L³.

The US EPA uses 2348 gCO₂e per liter of gasoline and 2689 gCO₂e per liter of diesel fuel⁴.

For electric vehicles the value used is 157 gCO₂e/kWh.

²I. Graabak, B.H. Bakken, N. Feilberg: "Zero Emissions Building and Conversion Factors between Electricity Consumption and Emissions of Greenhouse Gases in a Long Term Perspective", Environmental and Climate Technologies, 2014.

³<http://ecoscore.be/en/info/ecoscore/co2>

⁴"Greenhouse Gas Emissions from a Typical Passenger Vehicle", Office of Transportation and Air Quality, EPA, 2014.

Appendix D

Data file sample

Carbon footprint

Date	Housing	Transportation	Solar panel	Walking	Cycling	Electric car
2017-01-01	2.7949999999999995	3.57375804957514	2.8229360000000003	2.87375804957514	2.87375804957514	0.25526843211251
2017-01-02	2.8765	23.2137664319418	3.094840425531915	22.5137664319418	22.5137664319418	1.65812617371013
2017-01-03	3.0975	5.4697427355756	3.1172600724309643	4.7697427355756	4.7697427355756	0.390695909683971
2017-01-04	3.3495	9.95866674091126	3.319260072430964	9.25866674091126	9.25866674091126	0.711333338636518
2017-01-05	2.8789999999999996	4.17987571575272	2.9013467632412855	3.47987571575272	3.47987571575272	0.298562551125194
2017-01-06	3.006	5.63036077276993	2.883984	4.93036077276993	4.93036077276993	0.402168626626423
2017-01-07	2.7715	4.62558424015388	3.081840425531915	3.92558424015388	3.92558424015388	0.330398874296706
2017-01-08	2.4290000000000003	5.27207316089341	2.4655866908103214	4.57207316089341	4.57207316089341	0.376576654349529
2017-01-09	2.866	3.52768507955429	2.7539999999999996	2.82768507955429	2.82768507955429	0.25197750568245
2017-01-10	3.4299999999999997	5.03606431242644	3.3891733816206426	4.33606431242644	4.33606431242644	0.359718879459031
2017-01-11	3.298	4.73025919531602	3.3557600724309644	4.03025919531602	4.03025919531602	0.337875656808287
2017-01-12	3.982	10.130594881335	3.8871733816206433	9.43059488133501	9.43059488133501	0.723613920095358
2017-01-13	2.9355	5.89145256328092	3.129846763241286	5.19145256328092	5.19145256328092	0.420818040234352
2017-01-14	3.1995000000000005	28.525371945944	3.080673381620643	27.825371945944	27.825371945944	2.03752656756743
2017-01-15	2.526	6.43161347182391	2.6337600724309644	5.73161347182391	5.73161347182391	0.459400962273137
2017-01-16	3.129	51.1974287026722	3.0589999999999997	50.4974287026722	50.4974287026722	3.65695919304801
2017-01-17	3.4455	5.79680230302327	3.494086690810321	5.09680230302327	5.09680230302327	0.414057307358805
2017-01-18	2.7795	21.8186507301738	2.6595000000000004	21.1186507301738	21.1186507301738	1.55847505215527
2017-01-19	2.806	4.70473112664095	2.827760072430964	4.00473112664095	4.00473112664095	0.336052223331496
2017-01-20	3.426	5.41030494719259	3.3659999999999997	4.71030494719259	4.71030494719259	0.3864503533709
2017-01-21	2.8289999999999997	10.0090369423082	2.802520144861928	9.30903694230823	9.30903694230823	0.714931210164874
2017-01-22	3.12		0 3.240346763241286		0	0
2017-01-23	3.5970000000000001	4.20373086001692	3.4501733816206435	3.50373086001692	3.50373086001692	0.300266490001208
2017-01-24	3.253	17.6396003324996	2.9960000000000004	16.9396003324996	16.9396003324996	1.2599714523214
2017-01-25	2.9925000000000006	9.63233326397095	2.9485000000000006	8.93233326397095	8.93233326397095	0.688023804569354
2017-01-26	3.2409999999999997	5.30016393910244	3.2369359999999996	4.60016393910244	4.60016393910244	0.378583138507317
2017-01-27	2.9355	4.95287467328688	3.1535	4.25287467328688	4.25287467328688	0.353776762377634
2017-01-28	3.0100000000000007	12.3576445006269	2.7928880000000001	11.6576445006269	11.6576445006269	0.88268889290192
2017-01-29	2.4435000000000002	5.29819517218912	2.6915	4.59819517218912	4.59819517218912	0.378442512299223
2017-01-30	2.9185	5.96015072960604	2.7986004979628794	5.26015072960604	5.26015072960604	0.425725052114717
2017-01-31	2.8985000000000003	6.03514270820997	2.8845	5.33514270820997	5.33514270820997	0.431081622014998
2017-02-01	3.1005	3.83564532355333	2.9484999999999997	3.13564532355333	3.13564532355333	0.273974665968095
2017-02-02	3.4239999999999995	3.53576731363888	3.3289679999999997	2.83576731363888	2.83576731363888	0.252554808117063
2017-02-03	3.5944999999999996	4.35290446017249	3.7325	3.65290446017249	3.65290446017249	0.310921747155178
2017-02-04	3.6020000000000003	4.4690273335616	3.5139999999999993	3.7690273335616	3.7690273335616	0.319216238111543

Appendix E

Project files

The project can be downloaded at: <https://github.com/cminh/desent>