

THE NORWEGIAN WAVE-POWER BUOY PROJECT

K. Budal	Division of Experimental Physics	Norway
J. Falnes	The University of Trondheim	
L.C. Iversen	N-7034 Trondheim-NTH	
P.M. Lillebekken		
G. Oltedal	Division of Automatic Control	
T. Hals	SINTEF (The Foundation of Scientific	
T. Onshus	and Industrial Research at The	
	Norwegian Institute of Technology)	
	N-7034 Trondheim-NTH	
A.S. Høy	Department of Marine Engineering	
	The Ship Research Institute of Norway	
	N-7000 Trondheim	

Abstract

The paper describes a spherical buoy, which can perform heaving oscillations relative to a strut joined to an anchor on the sea bed. The buoy is supplied with latching means for optimum phase control and with an air turbine for power take-off. Measured signals of the local wave is applied to a Kalman filter for wave prediction and for the provision of unlatching signals. A model test of the axial-flow reaction turbine shows a conversion efficiency in excess of 0.8 for the full-scale power range 0.1-0.4 MW if the turbine speed is properly chosen within the range 2500-4000 r.p.m. A discussion is given of the wave power absorbed by a 200 MW plant consisting of an array of 410 buoys located off the Norwegian coast. On the basis of the state of technology in 1981 the wave power plant is not economically competitive in Norway. The estimated energy price is dominated more by labour than by investment in materials. This fact gives hope for future cost reduction. By further technical development the power-buoy plant may become economically competitive.

## 1. Introduction

For some years we have been working on optimising the conversion of ocean wave power by means of controlling the motion of the wave-power device [1-3]. The principle of optimised motion is quite general and can be applied to most wave power systems. However, we have mainly applied the ideas to a plant consisting of heaving power buoys. Considerable theoretical work has been done on the system [4-9, ref. 9 is a review paper] and experimental work has confirmed the theory [10-12].

In this paper the present design of the buoy is described. The control strategy and the air turbine are described in some detail. Some estimates as to the economy of a wave power plant are also presented. Although prospects are encouraging, it is evident that considerable full scale experimentation and the development of some new, inexpensive, reliable components have to be made in order to make wave power a realistic, economically acceptable new source of energy.

## 2. Point Absorber with Controlled Motion

The project to be presented here has concentrated on point absorbers with controlled motion. By point absorber is meant a wave energy converter with dimensions which are small compared to the wavelength. That the converter is controlled implies that the motion of the absorber is controlled in such a way that maximum power is absorbed from the waves.

Consider a body which is making heaving motions in the sea. In regular waves it is fairly easy to obtain optimum motion of the body. Then a simple damped mass-spring system will do. All that is necessary is to tune the system in such a way that the natural period of the body is equal to the period of the wave. Furthermore, the system should be properly damped. The damping may for instance be accomplished by an electric generator, delivering the useful power from the converter.

Ocean waves are not regular. This makes it considerably more difficult to perfectly optimise the motion of the converter. However, we have proposed a method which gives a motion which is very close to optimum and, moreover, which is fairly easy to accomplish. The method is demonstrated by curve c in figure 1.

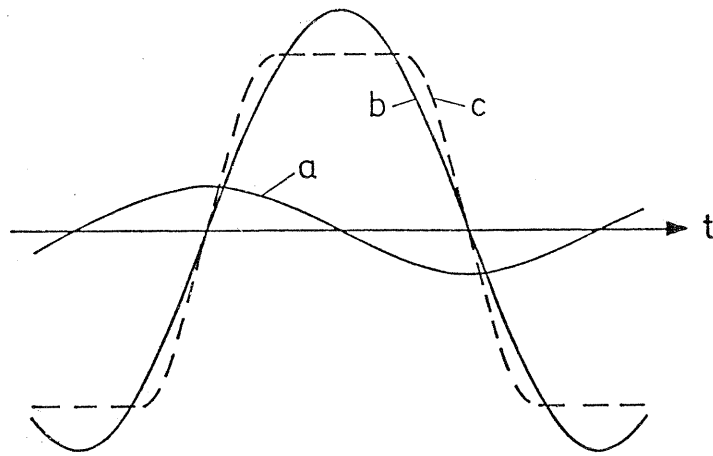

Figure 1. a: Wave elevation as a function of time.  
 b: Optimum displacement of buoy.  
 c: Actual displacement of buoy, where the position of the buoy is fixed (horizontal parts of curve) during controlled intervals of each wave cycle.

### 3. The Wave Energy Converter

#### 3.1. Principle of Operation

During the last three years we have evaluated several wave power converters with different types of machinery. So far we have rejected some of the proposals on economic reasons. Partly because the construction costs seemed to be too large and partly because maintenance was likely to be prohibitively expensive.

For the time being we are designing a device as shown in figures 2 and 3. The main body of the converter is a freely floating spherical hull with an opening to the sea at its lower end. The strut passing through the buoy and being joined to the sea floor, serves as a fixed reference for the body. By clamping the buoy to the strut during controlled intervals of each half cycle it is possible to obtain phase control of the motion of the buoy with respect to the wave.

When the buoy is latched in its upper position, the system is horizontally unstable. However, the horizontal movement of the buoy during the clamping interval is so small that the effect on the energy absorption is negligible.

The strut will be subject to bending moments due to:  
 a) relative horizontal motion between water and strut, b) pitching moments on the buoy due to the incident wave and c) acceleration forces on the strut, particularly due to the mass M (see figure 3).

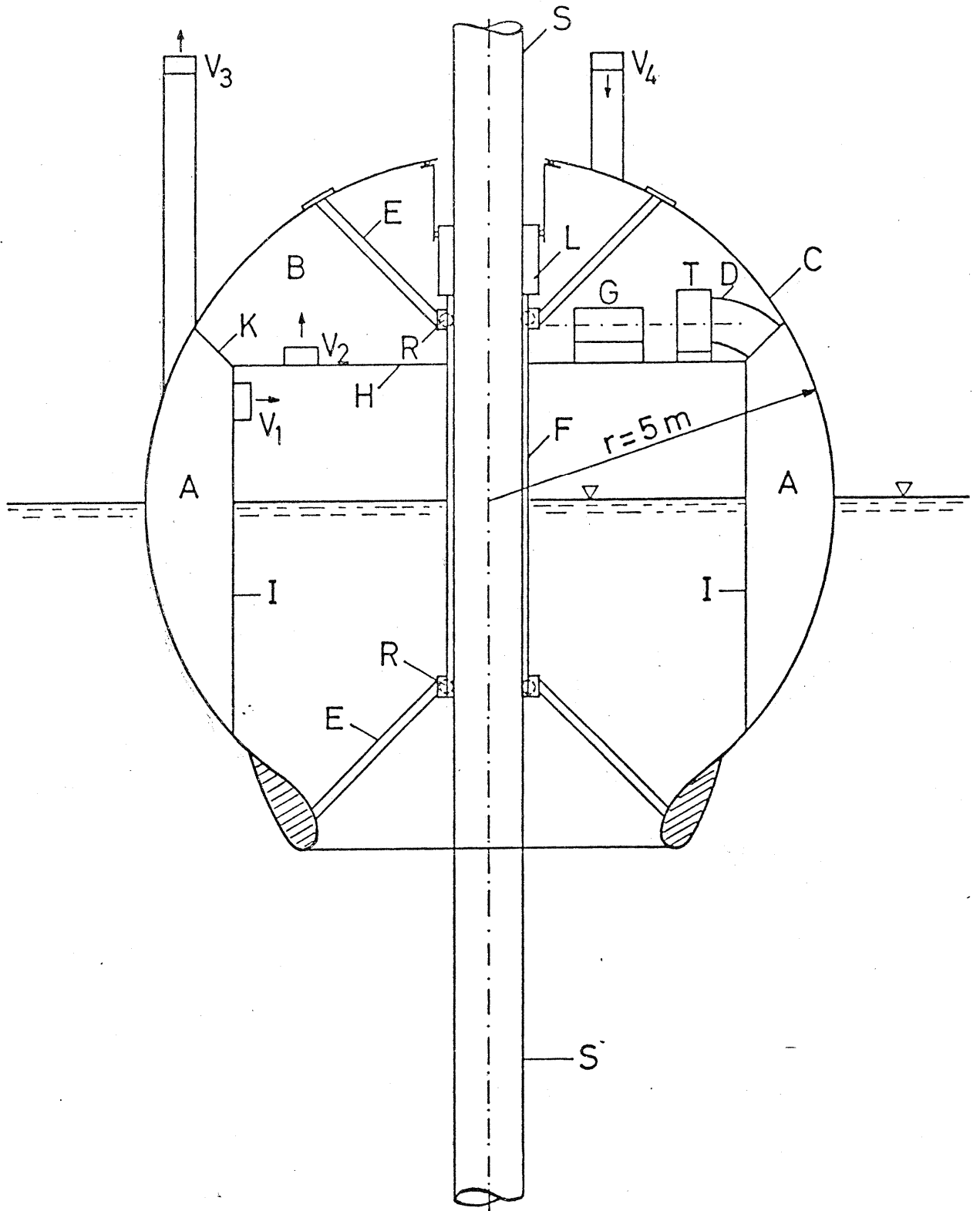

Figure 2. Wave energy converter. The hull of the buoy C is spherically shaped with an opening to the sea at its lower end. The cylindrical wall I gives the buoyancy chamber A. The horizontal deck H and the conical wall K separates another chamber B. The concentric cylinder F is fixed at its upper end and lower end to the hull of the body by means of rods E. The cylinder is provided with rollers R at its ends rolling on a vertical, cylindrical strut S connected to an anchor joint at the sea floor. The clamping mechanism L can lock the otherwise freely floating buoy to the strut. The turbine T is connected between chambers B and A by means of the tube D. The buoy is equipped with four non-return air valves  $V_1 - V_4$ .

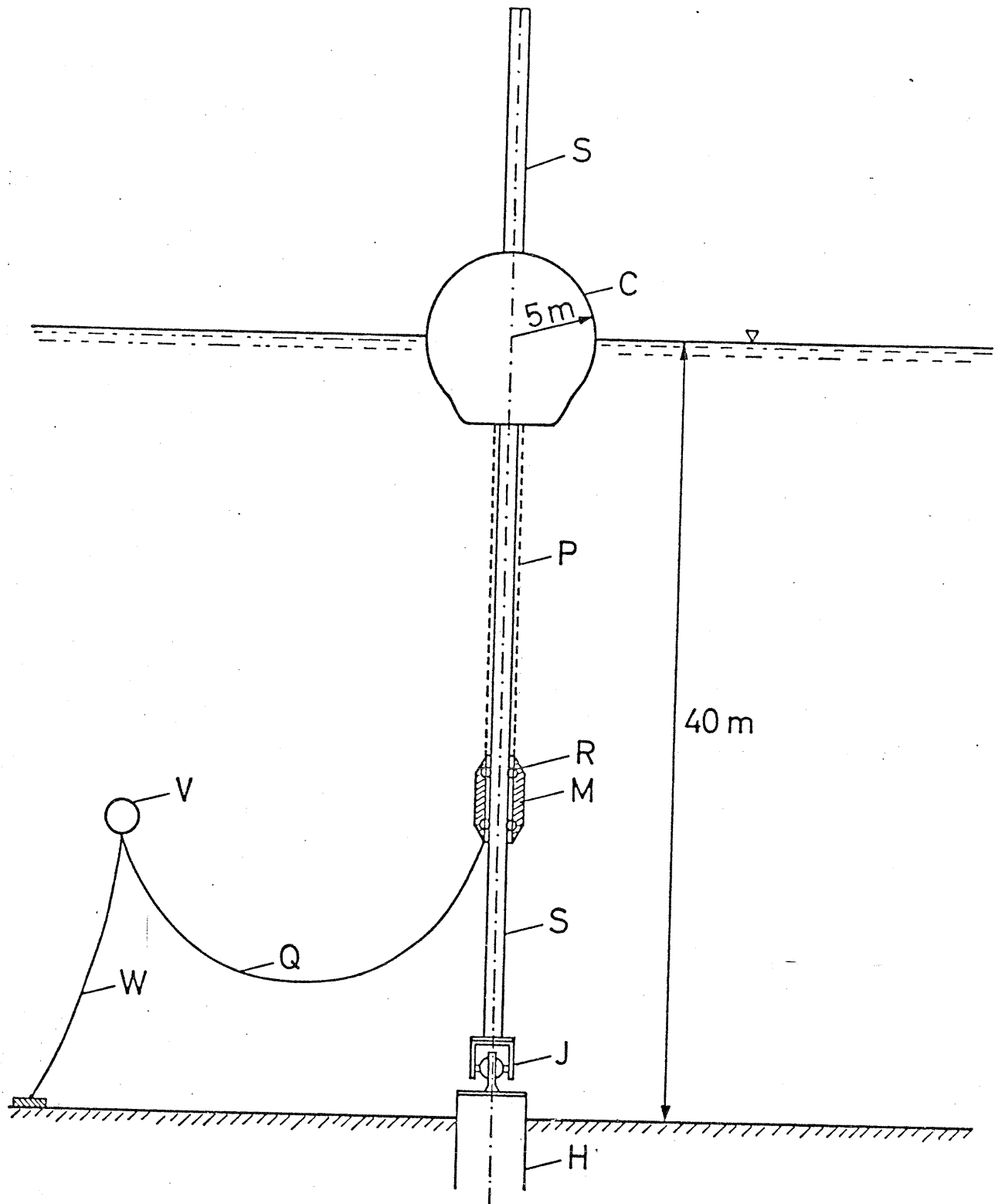

Figure 3. Mooring of wave energy converter. The strut *S* is connected to the sea floor through a universal joint *J* and an anchor *H*. A concentric, streamlined mass *M*, moveable along the strut by means of rollers *R*, is connected to the buoy by means of cables *P*. The mass assures that the strut has an equilibrium upright position. The electrical cable from the generator passes along the cables *P*, via the flexible cable *Q* to the buoyant body *V* and along the mooring cable *W* to the sea floor.

However, if the buoy is spherical, the pitching moment is almost eliminated. This is the main reason why the buoy has a spherical shape. Moreover, experiments [13] have shown that a spherical buoy is an efficient wave energy absorber. Furthermore, due to the doubly curved surface of the hull, economy of construction material is obtained.

Model tests of the system corresponding to the most extreme wave conditions expected off the Norwegian coast have been performed. The model test data have been used as design criteria for the system.

Phase control means that energy is efficiently converted from wave energy to kinetic and potential energy of the oscillating buoy. Hence, if the buoy had no damping its heave amplitude would quickly grow prohibitively large. In the buoy shown in figure 2, the damping is established as follows: The water surface inside the body serves as a kind of piston [14]. Due to the pneumatic stiffness of the air volume above the surface, the water inside the body will largely follow the motion of the body. When the sphere is clamped in its lower position, the air pressure above the water surface therefore will be larger than atmospheric pressure. Then air passes through the non-return valve  $V_2$  into chamber B. Similarly, when the buoy is clamped in its upper position, the air pressure will be below atmospheric pressure and air will pass from chamber A through the non-return valve  $V_1$ . Hence, between chambers A and B there will be established a pressure difference  $\Delta p$  which runs the turbine T. The energy storage in the air chambers A and B is not large enough to keep the turbine running with constant pressure. The pressure difference across the turbine will therefore oscillate. The valves  $V_3$  and  $V_4$  ensures that chambers A and B never obtain a pressure above or below atmospheric pressure, respectively. In fact, the four valves  $V_1 - V_4$  serve to rectify the air flow through the turbine [14], whereas chambers A and B only have a smoothing effect on the rectified air flow.

A key element of the machinery is the clamping device L. During one year there will on the average be  $6 \cdot 10^6$  clamping operations. Considerable effort has therefore been put into this device. However, although model tests are promising (see figure 4), only full scale tests will show if the present design is working according to expectations. If the buoy were to work without phase control, the power absorption would be much reduced, as is apparent from the theoretical curves in figure 5. For a typical wave with amplitude 1 m and period 9 s the optimum power absorption would be

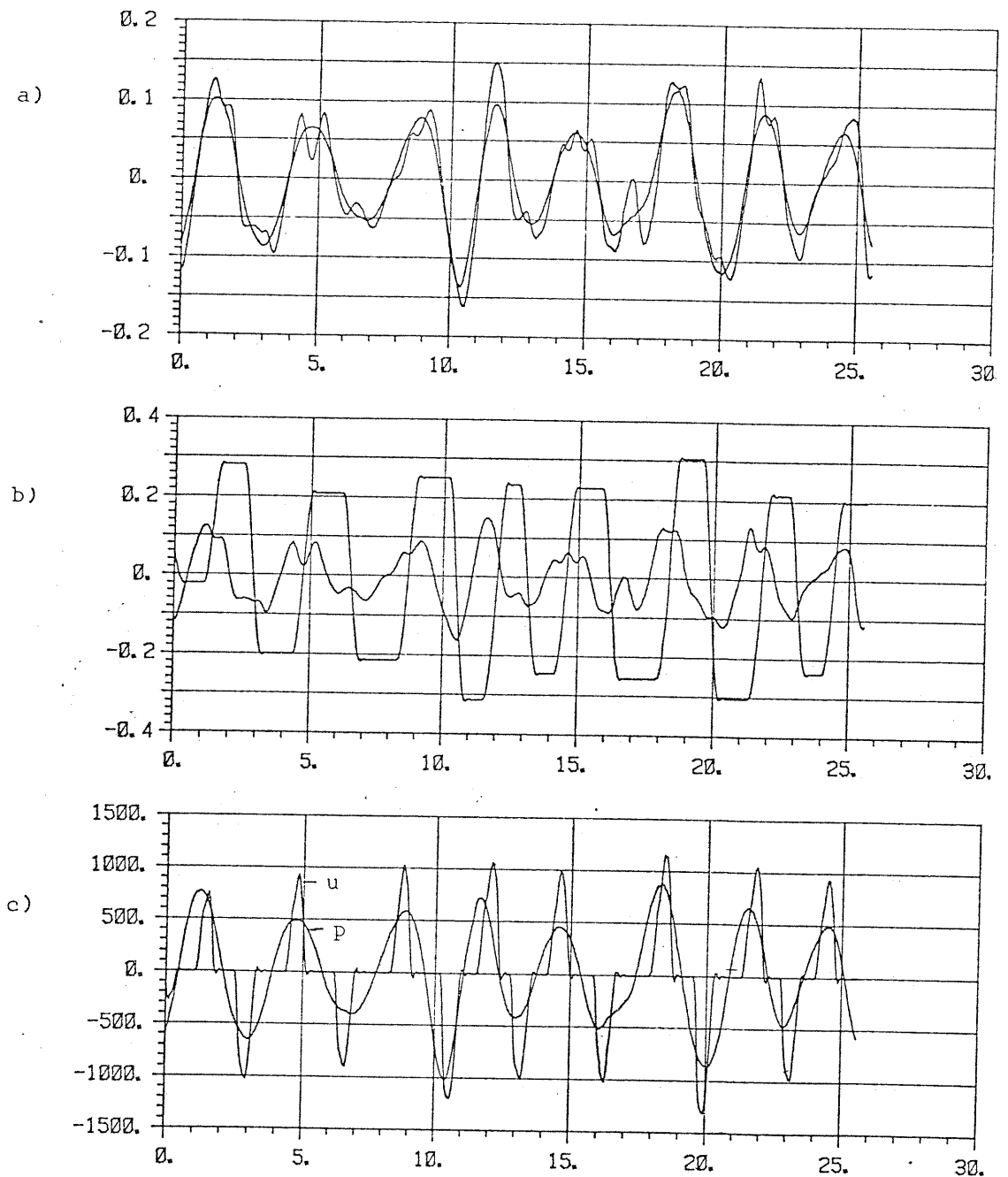

Figure 4. Measurements on a 1:10 scale model of the buoy. The horizontal axis represents time in seconds.

- Wave elevation  $\eta$  (in metres) is given by the more wavy curve. The smoother curve represents the hydrodynamic wave pressure  $p$  as measured by a stationary pressure transducer at a depth of 0.7 m, abreast the buoy.
- Heave displacement  $s$  of buoy and wave elevation  $\eta$  (both in metres).
- Wave pressure  $p$  (in  $\text{N/m}^2$ ) and heave velocity  $u = ds/dt$  of the latchable buoy (in relative units).

reduced roughly by a factor 5. Hence, the technical complications, that proper phase control inevitably introduces, have to be weighed against the improved power production.

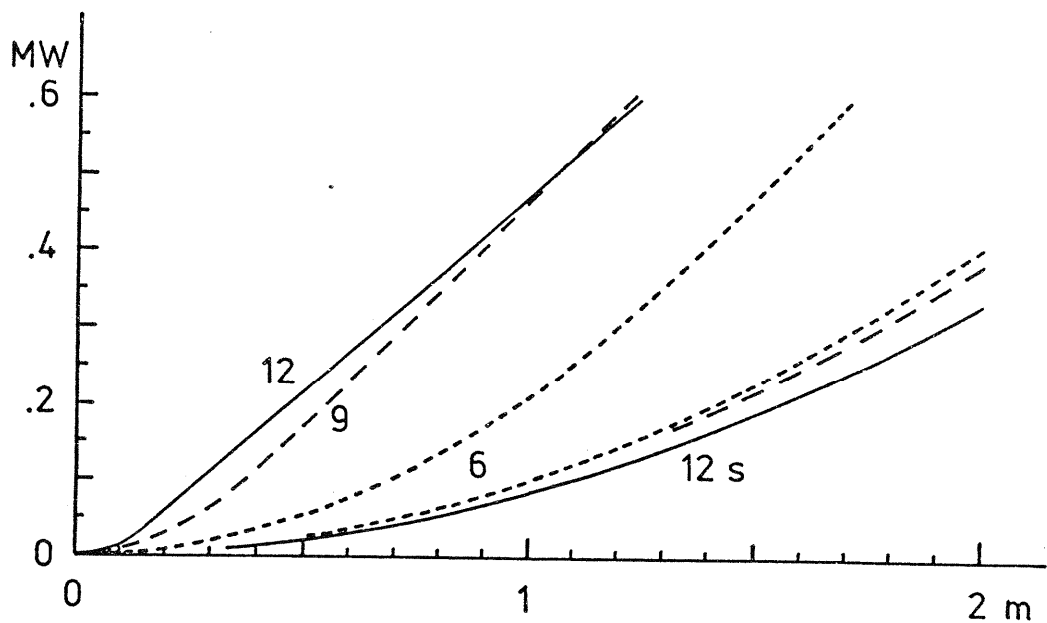

Figure 5. Theoretical curves for absorbed power as a function of amplitude of incident wave, for optimum motion of latched buoy (higher curves) and of non-latched buoy (lower curves). The wave period is 6, 9 and 12 seconds for the dotted, dashed and full curves, respectively. The buoy is a heaving sphere with diameter 10 m and natural period 4.7 s. For the straight part of the curves, the heave amplitude is constrained to 3 m.

### 3.2. Controlled Motion

The controlling of the buoy consists of two parts. One is to predict the incoming wave a certain time into the future. Strictly speaking, it is the excitation force on the buoy which is of real interest, but for a point absorber in heave it is assumed that the excitation force is proportional to the pressure,  $p$ , from the incident wave at the mean position of the buoy. Based upon the wave prediction the buoy is to be unlatched at a proper time relative to the trough or the crest of the wave. Secondly, the buoy is to be latched as closely as possible to its extreme positions of heave oscillation. Thus, due to the latching, information is needed about the motion of the buoy. Typically, a combination of the measured values of its velocity and acceleration can be used for this purpose. This will not, however, be discussed in more detail here.

At the present stage of the buoy project a digital filtering



technique called Kalman filtering [15, 16, 17] is used in order to predict the incident wave. The method is illustrated in fig. 6.

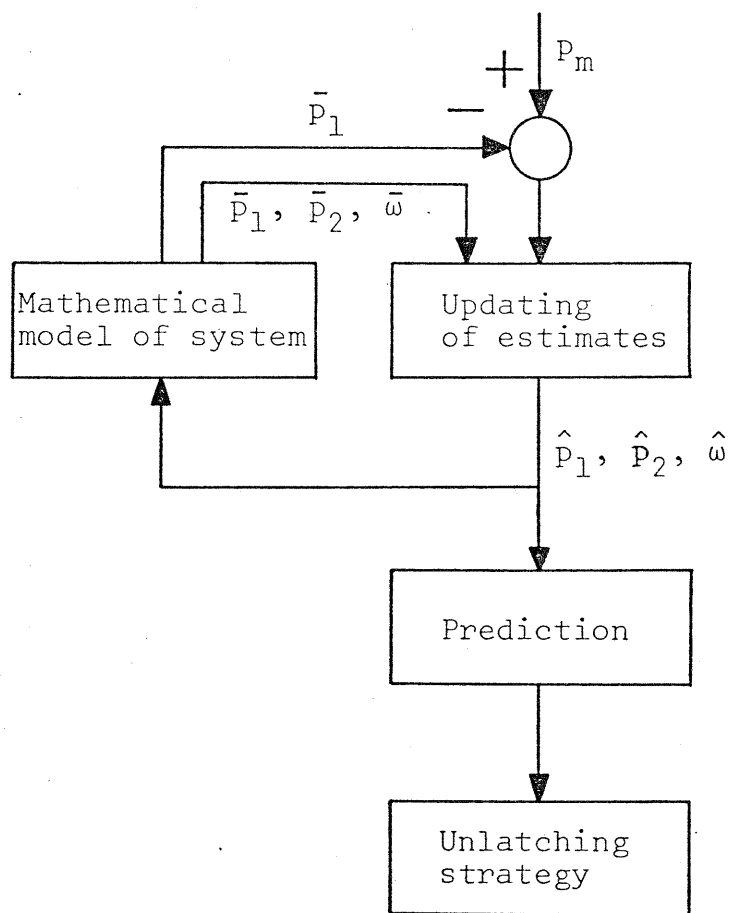

Figure 6. The structure of Kalman filtering as used for prediction of the incident wave.

Two basic assumptions have to be made. First, it is assumed that it is possible to measure the pressure from the incident wave at the position of the buoy. The measurement is denoted  $p_m$ . The second assumption is that the pressure,  $p$  as a function of time can be described by a mathematical model, such as

$$(1) \quad \ddot{p}(t) + d\dot{p}(t) + \omega(t)^2 p(t) = 0$$

where  $\omega$  is a time dependent angular frequency. A damping,  $d$ , is introduced in the model in order to assure numerical stability when solving the differential equation with a finite time resolution,  $\Delta t$ . Alternatively, eq. (1) can be written as

$$(2) \quad \dot{p}_1 = p_2$$

$$\dot{p}_2 = -dp_2 - \omega^2 p_1$$

when using  $p_1 = p$  and  $p_2 = \dot{p}$ . Further, we assume that the frequency  $\omega$  is slowly varying,  $\dot{\omega} \approx 0$ .

At every time step the situation at the previous time step can be used together with eq. (2) to give the so-called 'a priori estimates' of  $p_1$ ,  $p_2$  and  $\omega$ .

These estimates are denoted  $\bar{p}_1$ ,  $\bar{p}_2$ ,  $\bar{\omega}$ . Then, when  $p_m$  is measured the innovation,  $\epsilon$ , is given as

$$(3) \quad \epsilon = p_m - \bar{p}_1$$

The innovation can then be used to update the 'a priori estimates' to give the 'a posteriori estimates'  $\hat{p}_1$ ,  $\hat{p}_2$  and  $\hat{\omega}$ :

$$(4) \quad \hat{p}_1 = \bar{p}_1 + K_1 \epsilon$$

$$\hat{p}_2 = \bar{p}_2 + K_2 \epsilon$$

$$\hat{\omega} = \bar{\omega} + K_\omega \epsilon$$

where  $K_1$ ,  $K_2$  and  $K_\omega$  are the Kalman filter gains. These gains should in principle be updated at every time step by using the Kalman filtering optimization procedure. It can however be shown [16] that for a given wave state  $K_1$  and  $K_2$  will approach constant values with approximately 2-3% relative variations. If constant values are assumed for these two gains the following expression is found for  $K_\omega$ :

$$(5) \quad K_\omega = K_{\omega,0} \hat{\omega} \frac{K_1 \hat{p}_2 - K_2 \hat{p}_1}{(K_1 \hat{\omega})^2 + K_2^2}$$

Eq. (5) is found by imposing the following optimization criteria

$$(6) \quad \dot{\hat{\omega}} = - \frac{K_{\omega,0}}{2} \frac{\partial}{\partial \hat{\omega}} (\epsilon^2)$$

When the 'a posteriori estimates' at one time step,  $t_n$ , are known one can use the mathematical model, eq. (2) to advance one step and compute the 'a priori estimates' for the next time step,  $t_{n+1}$ . Because of the artificial damping a simple Euler integration can be applied.

$$\bar{p}_1(t_{n+1}) = \hat{p}_1(t_n) + \hat{p}_2(t_n)\Delta t$$

$$(7) \quad \bar{p}_2(t_{n+1}) = (1 - d\Delta t)\hat{p}_2(t_n) - \hat{\omega}(t_n)^2\hat{p}_1(t_n)\Delta t$$

$$\bar{\omega}(t_{n+1}) = \hat{\omega}(t_n)$$

Thus, by using the Kalman filter one has at every time step estimates for  $p_1$ ,  $p_2$  and  $\omega$ . These estimates can then be used in a harmonical model to predict  $p_1$  and  $p_2$  a given prediction time  $t_p$  into the future.

$$(8) \quad p_1(t_p) = \hat{p}_1 \cos \hat{\omega} t_p + \frac{\hat{p}_2}{\hat{\omega}} \sin \hat{\omega} t_p$$

$$p_2(t_p) = \hat{p}_2 \cos \hat{\omega} t_p - \hat{p}_1 \hat{\omega} \sin \hat{\omega} t_p$$

Finally, these predictions have to be used together with a strategy for determining the unlatching time of the buoy.

The method as described in the preceding has been tested in model experiments (scale 1:10) in a wave channel with typical wave spectra. The wave is measured with a sample interval which is in the order 1-3% of the zero upcrossing period,  $T_z$ . An example of some experimental results are shown in fig. 4. The experiments have shown that the present method does give a fairly good control of the motion of the buoy. The power loss due to inaccuracies in the unlatching of the buoy is estimated to be 5-15%. This is, however, in a 2-dimensional situation where the incident wave can be measured away from the buoy itself. In a real sea state the measuring probe has to be placed near the buoy where the radiated wave from the buoy may not any longer be negligible. Efforts are therefore now made in order to develop a prediction method which will work in a 3-dimensional environment.

### 3.3. The Air Turbine

The turbine output power level (600 kW maximum, 120 kW annual average) and the turbine pressure ratio (ca. 0.75 about atmospheric pressure) for the wave power buoy led to the investigation of an axial flow machine. Measurements on a model turbine designed for a rated full scale speed of 3000 rpm, and optimised for a full scale rated power input of 250 kW, have been completed. Measured optimum efficiency compares well with theoretical values for steady flow conditions. In actual operation, however, the turbine is working with cyclic air flow delivered via four banks of

rectifying, non-return air valves. The operating efficiency of the pneumatic power take-off, including losses in the turbine and rectifier valves, and applied to the 120 kW average annual power output, is estimated to 0.7.

The tested model turbine is a single stage reaction turbine with a free vortex blade design (T6 profile) and with adjustable guide nozzle angles ( $\alpha_1$  - angle) between  $5^\circ$  and  $35^\circ$ . The model turbine has a 250 mm diameter rotor designed for 9500 rpm rated speed (corresponding to 3000 rpm full scale). The turbine blades as well as the guide nozzles are made of cast polyamide containing 40% glass fiber. A highly smooth surface results with the casting process.

The polyamide material will also be used in the full scale turbine. Consequently, blade corrosion is eliminated and the likelihood of salt deposits is greatly reduced due to the smooth surfaces. Blades on the full scale rotor having a 950 mm diameter are designed to operate below 25% of allowable radial tensile stress at 5000 rpm, and below 5% of allowable bending stress at maximum air mass flow. The turbine will be protected from over-speeding by an electro-mechanical brake system. The turbine bearings are designed to work in the environment of a cyclic, incremental acceleration with amplitude 0.4 g associated with the buoy's heave motion.

Figure 7 shows turbine efficiencies versus output power levels resulting with (a) 3000 rpm and fixed nozzle angle of  $20^\circ$ , and with (b) fixed nozzle angle of  $27.5^\circ$  where speed varies from 2650 rpm to 4000 rpm. The power and the turbine speed are given in full-scale values. However, the measurements are performed on the model with steady flow conditions. A certain deterioration of overall efficiency is expected when operating the turbine in unsteady flow. Turbine air flow under actual service conditions in the power buoy is characterised by a steady component modulated up to 100% by a cyclic component having a period approximately half the wave period.

For generation of synchronous ac power the turbine must operate with constant speed according to curve (a) in figure 7. As readily seen the turbine operating scheme becomes more efficient if speed is allowed to vary as in curve (b). The latter strategy necessitates, however, that ac rectification followed by dc power transmission is employed. The optimum choice of turbine speed shown in figure 8 for each power level can be controlled via the field excitation if a synchronous generator is used.

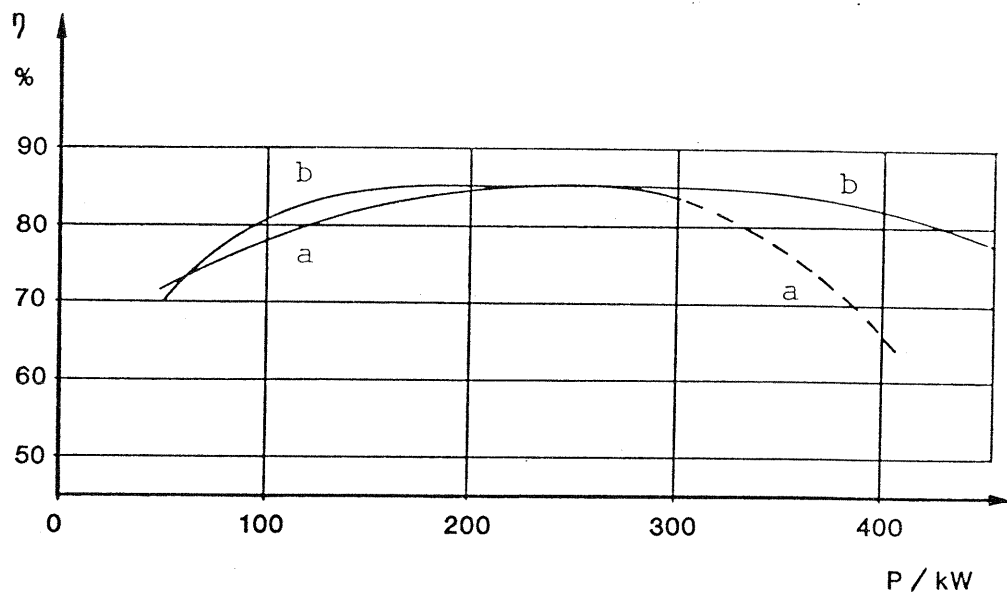

Figure 7. Model turbine efficiencies vs full scale power output.  
 Curve a: constant speed, 3000 rpm full scale, nozzle angle  $\alpha_1 = 20^\circ$ .  
 Curve b: variable speed, 2650-4000 rpm full scale, nozzle angle  $\alpha_1 = 27.5^\circ$ .

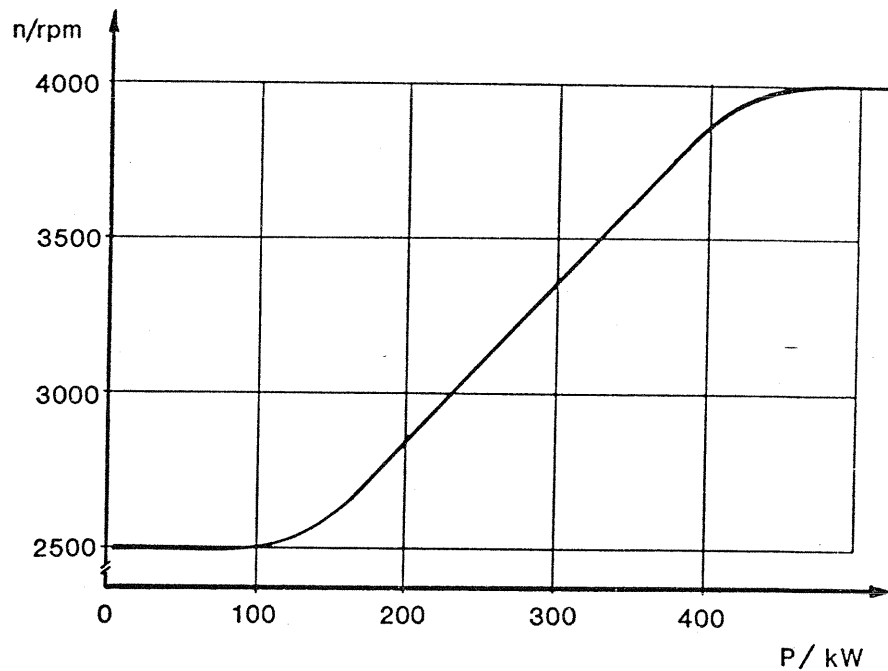

Figure 8. Optimum full scale turbine speed vs full scale power output at constant nozzle angle  $\alpha_1 = 27.5^\circ$ .

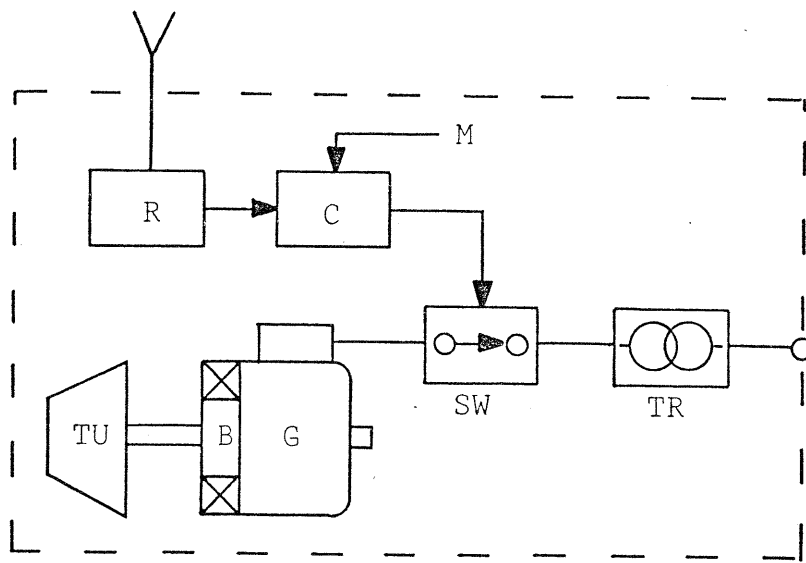

Figure 9. Buoy power plant.  
 TU - axial flow turbine, 500 kW, 3000 rpm  
 G - ac generator, asynchronous, 500 kVA, 400 V, 50 Hz, three-phase, 3000 rpm  
 B - electro-mechanical speed-runaway brake  
 SW - main power switch  
 TR - transformer, 500 kVA, 0,4 kV/12 kV, three-phase  
 C - controller for ON/OFF remote control  
 M - monitoring signals for local OFF-only control  
 R - one-way radio for ON/OFF commands

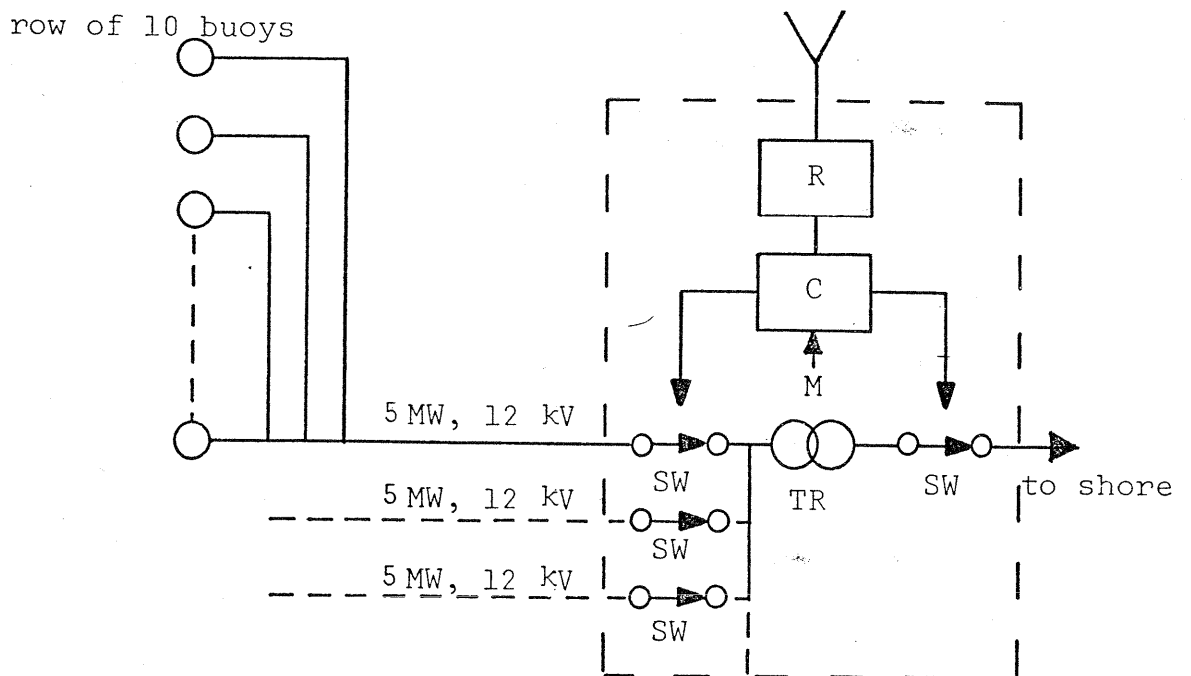

Figure 10. Transformer substation.  
 SW - power switches  
 TR - 200 MW transformer system  
 C - controller for remote ON/OFF control  
 M - monitoring signals for local control  
 R - radio for substation remote control and monitoring

### 3.4. Power Transmission

A scheme for ac power generation and transmission is shown in figures 9 and 10. The system includes the axial flow turbine directly connected to a 3000 rpm, asynchronous, 400 V, 50 Hz, three-phase generator rated at 500 kVA. An electro-mechanical speed run-away brake protects the rotating parts during power disconnects and cable failures. Maximum turbine power output is limited to less than 600 kW for any wave conditions because of flow saturation thus protecting the generator from mechanical and thermal overloads.

The generator output is fed to the primary of a 0.4 kV/12 kV, 500 kVA transformer via a power switch. The transformer's secondary connects to a highly flexible, reinforced, three-conductor cable for transmission of power from the heaving buoy to the sea floor power collecting cable system. Although flexible, subsea cables for the power and voltage range encountered here are commercially available, the flexible cable for application in this system must be developed further to achieve better-than-present cable fatigue life (1-2 years).

A typical 200 MW wave power station will comprise in the range of 4-500 power buoys deployed in strings, of five buoys along a stretch of 10-15 km length, and at a water depth of 40-50 m (figure 11). For Norwegian coastal conditions typical power transmission distances to the shore are 1-10 km. For longer transmission

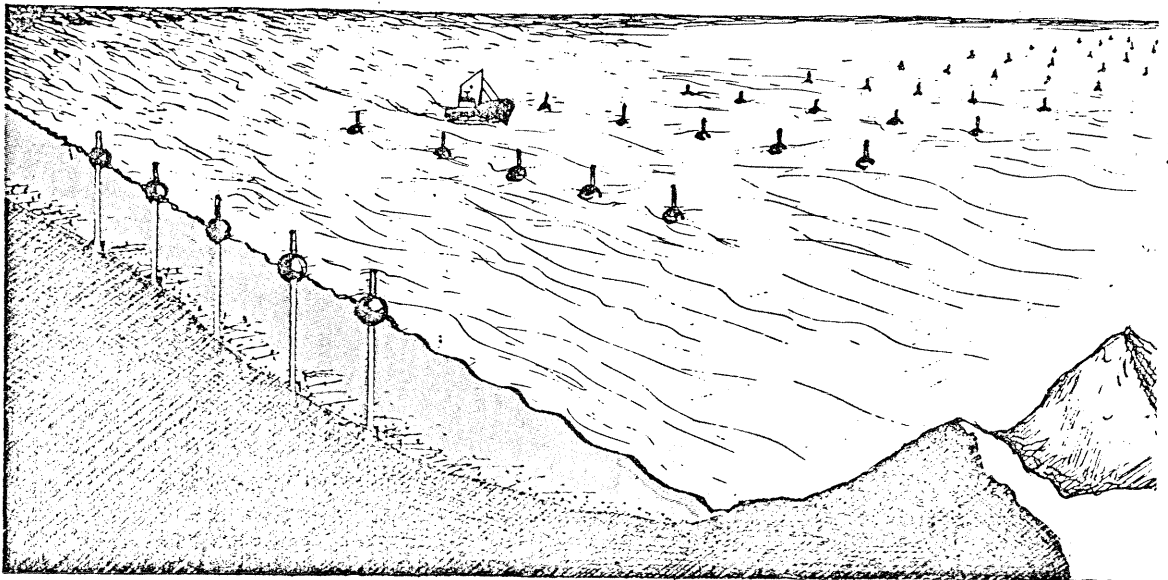

Figure 11. Power plant consisting of an array of wave-power buoys. The distance is 30-40 m between adjacent buoys in each group of five buoys. The distance between adjacent groups is approximately 120 m. The water depth is approximately 40 m.

distances one or two offshore power collecting, transformer substations (figure 10) may be economically advantageous for terminating paralleled 12 kV cables from groups of 10 power buoys. The power-on, power-off condition for each power buoy is remotely controlled by simple, one-way radio signal commands. The optimum power transmission system layout depends on a number of factors specific to each power station location. Such factors are: wave climate, bottom conditions, number of buoys, degree of interference with ship navigation and fishing interests, distance to shore and to the main power grid, capacity of main power grid, etc.

At present a trade off study comparing dc transmission/ac conversion to conventional ac transmission is being carried out within the power buoy project to verify possible cost benefits from operating the turbines at the higher efficiency with variable speed.

#### 4. Production of Energy by Power-buoy Plant

Since point absorbers are small compared to the wavelength they do not, in general, scatter the waves significantly. On this assumption we can, for a long configuration of power buoys as shown in figure 11, compute approximately the absorbed power as a function of amplitude, period and angle of incidence of a plane regular wave [18]. Further a computer program has been made to compute approximately the power absorbed from an irregular wave when the point absorbers have a limited heave amplitude. The input to the program is the scatter diagram corresponding to the wave climate at a chosen off-shore location.

Using instrumental wave data from the Norwegian coast at Halten ( $64^{\circ}\text{N}$ ,  $9^{\circ}\text{E}$ ) we find [19] that each group of 5 buoys (figure 1) absorbs a power of approximately 9 GWh per year when the interspacing between adjacent groups is  $d = 120$  m. The interspacing between adjacent buoys in a group is 30 to 40 metres. The spherical buoys have a diameter 10 m. A substantial part of the average year, the heave amplitude is constrained to 3 m. (Cf. the straight part of the power curves in figure 5.)

A smaller portion of the year, when the wave is rather low, the optimum amplitude is not constrained, and, as is well-known [7, 11, 18], all the incident wave power may be absorbed by less than five, but at least two, parallel rows of point absorbers (provided the wavelength is not too short).

At Halten the measured wave data correspond to an average power of 30 kW per metre wave crest. Directional wave data are lacking.



However, if we assume that the average incident power is 25 kW per metre of the power-buoy array, the power plant absorbs a fraction  $9 \cdot 10^9 / 120 \cdot 25 \cdot 10^3 \cdot 8760 = 0.34$  of this incident power. Since this fraction is small compared to one, approximately equal amounts of energy are absorbed by each of the five rows [18]. Hence, for an average year the absorbed energy per power buoy is approximately  $9 \text{ GWh}/5 = 1.8 \text{ GWh}$ .

It is possible to increase the absorbed fraction of the incident wave power by increasing the linear density of power buoys in the array, for instance by choosing the distance between adjacent groups of five buoys to be less than 120 m [19]. However, this would impair the economy of the plant, since the absorbed energy per buoy would be reduced.

Some part of the absorbed wave energy is lost by viscous dissipation in the sea water, and by friction and heat losses in the latching mechanism, guiding rollers, air valves, turbine, electric generator etc. We shall here assume that a total conversion efficiency of 0.6 is obtainable by an optimised and well-designed system. In this case the average energy production per power buoy is approximately 1 GWh per year.

This figure agrees fairly well with the power production of an assessed [20] wave power plant off the Norwegian coast at Bremanger ( $62^\circ\text{N}$ ;  $5^\circ\text{E}$ ). In this case hindcast data were used as input to our computer program.

##### 5. Costing of Power Buoy Plant

The Royal Ministry of Petroleum and Energy has issued a report on renewable energy sources in Norway [20]. On the basis of the technological state in 1981 the cost of construction and installation was estimated to 6.6 Mkr (£0.6M) per power buoy. For a 200 MW plant consisting of 410 buoys, arranged as indicated in figure 1, a total cost figure of 3,6 Gkr (£350M) was given. This figure includes cost for electric transmission, interest during construction time and 10% investment tax. The annual maintenance cost was estimated to be 0.55 Mkr (£0.05M) per buoy. This was based on prototype design rather than on a construction of well-developed and reliable components. Further, the chosen maintenance procedure has not been economically optimised. On the basis of the above figures an energy cost of 1.40 kr/kWh (0.13 £/kWh) is obtained if the annual interest is 7% and if the lifetime of the plant is 20 years. Judged by this figure wave power is not yet economically compe-

titive in Norway.

Note that the labour contributes much more to the cost than materials do. For optimally controlled point absorbers the investment of materials (and energy) is relatively small. This fact gives hope for future cost reduction of point absorbers.

In order to make wave power economically competitive it is necessary to continue the effort of research and technological development in this field, which has been investigated only over a few years. It is required to

- (i) develop power buoys with mechanical and electrical components to a high level of reliability,
- (ii) utilise a maintenance procedure which is economically optimal,
- (iii) take advantage of cost reduction by mass production,
- (iv) optimise the shape and dimension of the power buoy and its machinery, and
- (v) consider other construction materials than steel.

We shall here present our own cost estimate, where we try to take into account the three points (i) to (iii) above.

For the first large power plant constructed we estimate the investment to be as indicated by the higher figures in the tables 1 and 2. It is well-known that price has a tendency to decrease with increasing production volume. For electricity production in USA the price of electricity decreased from 1926 to 1970 by a factor of 5, as measured in "1970 dollars" [21, figure 11.4]. The trend is a 25% decline in price for each doubling of cumulative production. Similar trends are experienced also for other products, e.g. oil or computers. We expect the same may happen with wave power plants, in particular with power buoys, since the cost is more dominated by labour than by materials. The lower figures in the tables 1 and 2 account for such cost reduction as many large power buoy plants may be constructed in the future.

Taking the lower and higher figures in table 2 as limits, the investment for the 200 MW power-buoy plant will be 1-2 Gkr (£100-200 M). The corresponding relation between investment and energy production is in the region 2-4 kr (£0.2-0.4) per kWh/year.

We presume that a large power-buoy plant will not be constructed before very reliable components have been developed. For the annual maintenance cost we then assume 3% of the investment, in accordance with a British wave energy assessment [22].

With 7% annual interest and with a plant lifetime of 20-25

Table 1. Estimate of construction cost per power buoy.  
 The lower figures indicate cost reduction after many large wave power plants have been constructed.  
 Prices in Mkr ( $= 10^6$  Norwegian kroner  $\approx$   $\pounds 9 \cdot 10^4$ )

	Higher	Lower
Hull of buoy, steel, 45 t	0.6	0.3
Mooring strut, steel, 53 t	0.32	0.22
Universal joint, $\pm 30^\circ$	0.14	0.1
Mechanical components	0.9	0.5
Electrical components	0.2	0.16
Anchor	0.8	0.2
Installation at site	0.6	0.3
Miscellaneous and contingency	0.3	0.2
Installed wave-power buoy	3.8	2.0

Table 2. Cost estimate for 200 MW power plant consisting of 410 power buoys.  
 Prices in Gkr ( $= 10^9$  N.kr  $\approx$   $\pounds 9 \cdot 10^7$ )

	Higher	Lower
Construction and installation of 410 buoys	1.5	0.8
Electrical transmission	0.12	0.07
Interest and other costs	0.1	0.05
Investment tax, 10%	0.16	0.09
Invested capital for power plant	1.9	1.0

341

years we then arrive at a future energy price of roughly 0.25-0.5 kr/kWh (0.025-0.05 £/kWh). This indicates that power-buoy plants may be developed to an economically competitive level in coastal countries having their electricity produced from oil. If the lower cost limit can be reached, the wave power plant may be economically competitive even in Norway.

Note that the cost figures presented here are based on a particular design of a spherical power buoy of diameter 10 m and installed generator 0.5 MW. This design have not been optimised. Perhaps it will pay to increase the diameter. The ratio between absorbed power and the volume of the buoy will then be smaller. However, it is probable that costs of e.g. installing and of maintenance, will then be of less relative importance. Moreover, other construction materials than steel, e.g. plastic or concrete, may result in improved economy for the power-buoy plant.

It should be emphasised that the cost figures given here have some uncertainty. More reliable figures can be obtained by further development, including construction and testing of prototype power buoys.

## 6. Conclusion

Taking into consideration the uncertainty of the above estimate, the following conclusion may nevertheless be drawn: At the present stage wave energy is not competitive with hydroelectric power in Norway. However, the cost of wave energy may be brought down by several means: 1) Optimisation of the size of buoys, 2) Mass production of units in specialised factories, 3) Development of cheaper mechanical components, with less maintenance and repair costs, 4) Alternative construction materials in the structure and 5) Improved installation procedure.

Real progress is probably hard to obtain unless a full scale prototype is built. This would be the next natural step to take.

## Acknowledgements

The described project is financially supported by The Royal Ministry of Petroleum and Energy (In Norwegian: Olje- og energi-departementet). Several engineering aspects of the project are coordinated through the research consortium OTTER (Offshore Technology Testing and Research) in Trondheim.

## References

- 1 BUDAL, K. and FALNES, J., "A resonant point absorber of ocean wave power", Nature, Vol. 256, 1977, pp. 478-479. (With "Corrigendum", Vol. 257, 1975, p. 626.)
- 2 AMBLI, N., BUDAL, K., FALNES, J. and SØRENSEN, A., "Wave power conversion by a row of optimally operated buoys", The Tenth World Energy Conference, Istanbul - Turkey, Sept. 19-23, 1977, division 4, §4.5-2.
- 3 FALNES, J. and BUDAL, K., "Wave-power conversion by point absorbers", Norwegian Maritime Research, Vol. 4, No. 6, 1978, pp. 1-11.
- 4 BUDAL, K. and FALNES, J., "Power generation from ocean waves using a resonant oscillating system", Marine Science Communication, Vol. 1, 1975, pp. 269-288.
- 5 NEWMAN, J.N., "The interaction of stationary vessels with regular waves", Proc. 11th Symp. Naval Hydrodynamics, 1976, pp. 491-501.
- 6 EVANS, D.V., "A theory for wave-power absorption by oscillating bodies", J. Fluid Mech., Vol. 77, 1976, pp. 1-25.
- 7 BUDAL, K., "Theory for absorption of wave power by a system of interacting bodies", Journal of Ship Research, Vol. 21, 1977, pp. 248-253.
- 8 BUDAL, K. and FALNES, J., "Optimum operation of improved wave-power converter", Marine Science Communications, Vol. 3, 1977, pp. 133-150.
- 9 EVANS, D.V., "Power from water waves", Ann. Rev. Fluid Mech., Vol. 13, 1981, pp. 157-187.
- 10 BUDAL, K. and FALNES, J., "Interacting point absorbers with controlled motion", In: B. Count (ed.) "Power from sea waves", London, Academic Press, 1980, pp. 381-399.
- 11 BUDAL, K., FALNES, J., KYLLINGSTAD, A. and OLTEDAL, G., "Experiments with point absorbers". Proc. First symposium on wave energy utilization, Chalmers University of Technology, Gothenburg, Sweden, 29 Oct.-1 Nov., 1979, pp. 253-282.
- 12 BUDAL, K., FALNES, J., HALS, T., IVERSEN, L.C. and ONSHUS, T., "Model experiment with a phase-controlled point absorber", Second Int. Symp. on Wave and Tidal Energy, Sept. 23-25, 1981, pp. 191-205.
- 13 LILLEBEKKEN, P.M., "Kuleformet, flytende kraftbøymodell. Hydrodynamiske parametre og energiabsorpsjon". Thesis, NTH, Trondheim, 1980.
- 14 MASUDA, Y., "Study of wave-activated generator for island power and land power", 11<sup>e</sup> Colloque International sur l'Exploitation des Oceans, Bordeaux, France, 1-4 octobre, 1974, Vol. 2, Bx119 (9 pages).

- 15 JAZWINSKI, A.H., "Stochastical Process and Filtering Theory", Academic Press, New York, 1972.
- 16 BALCHEN, J.G., JENSEN, N.A., MATHIESEN, E. and SÆLID, S., "A dynamic position system based on Kalman filtering and optimal control". Modeling, Identification and Control, 1 (3), pp. 135-163 (1980).
- 17 ONSHUS, T., "Optimal phase control of power-buoy", SINTEF report STF48 F79038 (1979).
- 18 FALNES, J. and BUDAL, K., "Wave power absorption by parallel rows of interacting oscillating bodies", Applied Ocean Research, to be published.
- 19 BUDAL, K. and FALNES, J., "Wave power conversion by point absorbers. A Norwegian project", The International Journal of Ambient Energy, to be published.
- 20 Olje- og energidepartementet (The Royal Ministry of Petroleum and Energy), "Nye fornybare energikilder i Norge" ("New renewable energy sources in Norway"), Stortingsmelding nr. 65 (1981-82), Oslo 1982-03-26.
- 21 FISCHER, J.C., "Energy Crisis in Perspective", J. Wiley & Sons, New York, 1974.
- 22 GROVE-PALMER, C.O.J., "Estimating the cost of power from sea waves", Energy Technology Support Unit, Building 156P, AERE, Harwell, Oxon, Report April 1981.