



Norwegian University of
Science and Technology

Composite Distribution System Reliability Evaluation

Effect of Interaction between Distribution
Substation and Primary Distribution System

Zaw Win Htun

Master of Science in Electric Power Engineering

Submission date: July 2017

Supervisor: Vijay Vadlamudi, IEL

Norwegian University of Science and Technology
Department of Electric Power Engineering



Norwegian University of
Science and Technology

Composite Distribution System Reliability Evaluation

-Including Effect of Interaction Between Distribution
Substation and Primary Distribution System

Zaw Win Htun

Master of Electric Power Engineering
Submission date: July 2017
Supervisor: Vijay Vadlamudi, IEL

Norwegian University of Science and Technology
Department of Electric Power Engineering

Abstract

A electric power system is generally composed of generation system, transmission system and distribution system. The reliability evaluation of the power system has become important and many researches have done in the power system reliability study area in order to improve the performance of the power system and economic reasons. As substation is one of the most important infrastructure in electric power system and has the great impact on the distribution system reliability, reliability evaluation of the substation and its impact on the distribution system reliability can be a great interest for this thesis.

This thesis uses minimal cut set method and fault tree analysis method to investigate the substation reliability and composite distribution system reliability. Minimal cut set method has been widely used in the reliability evaluation of substation, switching station and distribution system due to its benefits to list all possible causes of system failure depending on the failure mode of each component in the system. Fault tree analysis is also utilized extensively to conduct the reliability evaluation of the power system. It is especially utilized in reliability evaluation related to the protection systems.

This thesis work examines the reliability of five substation configurations by using the minimal cut set methods. The alternative approach for substation reliability evaluation has also been investigated by fault tree analysis. Many of the research papers and thesis works have done in this field by using commercial software such as NETPLAN, PSS/E, SUBREL, RISKSPECTRUM and so on which are expensive to buy as individual student and relatively few studies have done detailed calculations of the reliability indices of the substation and distribution system. Therefore, the detailed calculations of the evaluation of substation reliability and the effect of interaction between the distribution substation and primary distribution system are conducted based on one of the existing research paper to prove the

correct approach for the analysis and to improve the better understanding of the methods without using any commercial software. Fault tree analysis is also investigated to use as an alternative approach to evaluate the reliability of distribution substation and composite distribution system.

Summary

This thesis examines the reliability analysis of distribution substation by using minimal cut set method and fault tree analysis (FTA). The five types of distribution substations are adapted from existing literature [2] to illustrate the detailed calculation of the substation reliability indices. The impact of the substation reliability on composite distribution system is also analyzed by using minimal cut set approach. The five types of primary distribution system are taken and modified from RBTS Bus 4 [2] and used for reliability assessment of composite distribution system. The substation reliability models, the interaction between the distribution substation and primary distribution system model and primary distribution system reliability model are adapted from literature [2] and conduct the detailed calculation by using Microsoft Excel software. In addition to load point reliability indices, system reliability indices of the composite distribution system are also analyzed by using minimal cut set method to illustrate the serverity of system failures and the impact of substation reliability upon composite distribution system reliability.

Fault tree analysis (FTA) approach is also used to analyze the same substation configuration with same reliability data for comparing with minimal cut set method and to provide as the alternative approach for reliability assessment of distribution substation.

Preface

I would like to express my sincere gratitude to my supervisor, Associate Professor Vijay Venu Vadlamudi for his kind understanding during difficult times of my thesis works, valuable suggestions and guidance throughout master thesis.

I owe special thanks to Ministry of Energy and Electric Power (MOEE), Myanmar and Norwegian Water Resources and Energy Directorate (NVE) for offering me to do master degree at Norwegian University of Science and Technology (NTNU).

I gratefully thank all my teachers at NTNU for teaching me to improve my academic studies and to broaden my outlooks related to the engineering studies.

I would also like to thank my international and Norwegian friends who have treated me kindly and helped me in my academic studies as well as social environment.

Finally, I would like to thank all my parents and my wife for their love, patience and encouragement.

Trondheim, July 2017

Zaw Win Htun

Contents

Abstract	iii
Summary	v
Preface	vi
Abbreviations	x
Nomenclature	xii
List of Figures	xv
List of Tables	xiv
1. Introduction	1
1.1 Background	1
1.2 Scope	2
1.3 Thesis Outline	2
2 Literature Study	3
2.1 Overview on Reliability Test System	3
2.2 Overview on Reliability Evaluation Methods	5
2.2.1 Overview of Minimal Cut Set Method	6
2.2.2 Overview of Fault Tree Analysis (FTA)	7
3 Reliability Theory and Substation Structures	9
3.1 Basic Reliability Concept	9
3.2 Terms and Definitions of Reliability Indices	11
3.2.1 Basic Reliability Indices	11
3.2.2 System Reliability Indices	12
3.3 Substation Structures	13
3.3.1 Single Bus – Single Breaker Configuration	14

3.3.2	Double bus – Single Breaker with Bus Coupler Configuration	15
3.3.3	Double Bus – A Breaker-And-A-Half Configuration	15
3.3.4	Double Bus – Double Breaker Configuration	16
3.3.5	Ring Bus Configuration	17
3.4	Composite Test System	18
3.4.1	RBTS Bus 4 Distribution Test System	20
4	Case Study: Utilizing Minimal Cut Set Approach for Substation and Composite Distribution System Reliability	22
4.1	Substation Reliability	23
4.1.1	Reliability Indices Calculation for Single Bus Configuration	25
4.2	Composite Distribution System Reliability	30
4.2.1	Effect of Interaction between Distribution Substation and Primary Distribution System	34
4.2.2	Reliability Model for Primary Distribution System	35
4.2.3	Composite Load Point Reliability Evaluation Model	36
4.2.4	Calculation of Load Point Reliability Indices for Distribution System	36
4.2.5	Calculation of System Reliability Indices for Distribution System	45
5	Case Study: Utilizing Fault Tree Analysis for Substation Reliability	51
5.1	Investigation of Fault Tree Approach for Substation Configuration ‘a’	51
5.2	Investigation of Fault Tree Approach for Substation Configuration ‘b’	56
6	Conclusions and Future Works	60
6.1	Discussion and Conclusions	60
6.2	Limitations	62
6.3	Future Works	63
	Bibliography	64
A	Basic Distribution System Data of RBTS Bus 4	68
B	Calculation Results for Reliability Indices of Five Distribution Substations	71

C	Calculation Results for Load Point Reliability Indices of Five Distribution System	82
D	Calculation Results for System Reliability Indices of Five Distribution System	88

Abbreviations

ACCI	- Average Customer Curtailment Index
AENS	- Average Energy Not Supplied
APM	- Application of Probability Method
ASAI	- Average Service Availability Index
ASUI	- Average Service Unavailability Index
BB	- Busbar
BE	- Basic Event
CB	- Circuit Breaker
CAIDI	- Customer Average Interruption Duration Index
ENS	- Energy Not Supplied Index
ETA	- Event Tree Analysis
F	- Feeder
FTA	- Fault Tree Analysis
FOR	- Forced Outage Duration
HL I	- Hierarchical Level I
HL II	- Hierarchical Level II
HL III	- Hierarchical Level III
IE	- Intermediate Event
IEEE-RTS	- IEEE Reliability Test System
LCC	- Life Cycle Cost
LP	- Load Point
N/C	- Normally Closed
N/O	- Normally Opened
MC	- Monte Carlo
MM	- Markov Modelling
PSR	- Power System Reliability

RBD	- Reliability Block Diagram
RBTS	- Roy Billiton Test System
PSS/E	- Power System Simulator for Engineering
SUBREL	- Substation Reliability
SAIDI	- System Average Interruption Duration Index
SAIFI	- System Average Interruption Frequency Index
T	- Transformer
TE	- Top Event

Nomenclature

A	- Availability
λ_A	- Active failure rate of a distribution component
$\lambda_{A(Bi)}$	- Active failure rate of circuit breaker, i refers to breaker number
$\lambda_{P(Bi)}$	- Passive failure rate of circuit breaker, i refers to breaker number
$\lambda_{T(Bi)}$	- Total failure rate of circuit breaker, i refers to breaker number
$\lambda_{A(Ti)}$	- Active failure rate of transformer, i refers to transformer number
λ_T	- Total failure rate of a distribution component
λ_M	- Maintenance rate of a distribution component
$\lambda_{T(BBi)}$	- Total failure rate of busbar, i refers to busbar number
$\lambda_{X_i+Y_i}$	- Overlapping failure rate of component X and component Y, i refers to component number
$\lambda_{CB,i}^a$	- Average failure rate of load point contributed to by active failure of feeder circuit breakers.
λ_{cb}^p	- Passive failure rate of a circuit breaker.
$\lambda_{S,i}$	- Average failure rate of load point contributed to by the distribution substation itself.
λ_{cb}^a	- Active failure rate of a feeder circuit breaker
λ_a	- Failure rate contributed by active failure mode
λ_s	- Failure rate contributed by stuck breaker failure mode
λ_i	- Failure rate at load point i
λ_t	- Failure rate contributed by total failure mode
$\lambda_{T(BBi)}$	- Total failure rate of busbar i
μ	- Expected repair rate
MTTM	- Mean Time To Maintenance
MTTR	- Mean Time To Repair
MTTR _{BBi}	- Mean Time To Repair for busbar, i refers to busbar number

- $MTTR_{Ti}$ - Mean Time To Repair for transformer, i refers to transformer number
- P_C - Probability of stuck breaker failure mode
- $P_{C(Bi)}$ - Probability of stuck breaker failure mode for circuit breaker, i refers to breaker number
- U_a - Unavailability contributed by active failure mode
- $U_{A(Bi)}$ - Unavailability of circuit breaker due to active failure rate, i refers to breaker number
- $U_{T(Bi)}$ - Unavailability of circuit breaker due to total failure rate, i refers to breaker number
- $U_{A(Ti)}$ - Unavailability of transformer due to active failure rate, i refers transformer number
- $U_{T(Bi)}$ - Unavailability of circuit breaker, i refers to breaker number
- U_i - Unavailability at load point i
- U_t - Unavailability contributed by total failure mode
- $U_{T(BBi)}$ - Total unavailability of busbar, i refers to busbar number
- $U_{X_i+Y_i}$ - Unavailability due to overlapping failure rate of component X and component Y , i refers to component number
- N_i - Number of customers of load point i
- $La(i)$ - Average load connected to the load point i
- r - repair time
- s - switching time
- s_{Ti} - switching time of transformer, i refers to transformer number
- N_{cb} - Number of feeder circuit breakers connected at the same low voltage bus.
- r_{cb} - Repair time for a feeder circuit breaker.
- t_s - Time required to perform the required isolation, switching, and load transfer actions.
- $\lambda_{stuck,i}$ - Average failure rate of load point contributed to by active failures of main feeder sections in combination with an associated stuck circuit breaker.
- $U_{CB,i}^a$ - Annual outage time of load point contributed to by active failure of feeder circuit breakers.
- $U_{stuck,i}$ - Annual outage time of load point contributed to by active failures of main feeder sections in combination with an associated stuck circuit breaker.

- λ_m - Failure rate of the main section of a primary feeder.
- N_m - Total number of main feeder sections connected at the same low voltage bus.
- F_{mi} - Number of main sections of a primary feeder which services load point i
- λ_{ti} - Failure rate of a distribution transformer that services load point i
- λ_{li} - Failure rate of a lateral that services load point i
- r_m - Repair time for a main feeder section.
- r_{ti} - Repair time for the distribution transformer that services load point i
- r_{li} - Repair time for the lateral that services load point i
- $U_{S,i}$ - Annual outage time of load point contributed to by the distribution substation itself.

List of Figures

3.1	Functional zones and hierarchical levels of a power system	10
3.2	Simplified single bus single breaker configuration	14
3.3	Simplified double bus single breaker with bus couplers configuration	15
3.4	Simplified double bus a-breaker-and-a-half configuration	16
3.5	Simplified double bus double breaker configuration	17
3.6	Simplified ring bus configuration	18
3.7	Single line diagram of RBTS	19
3.8	Single diagram of RBTS Bus 4 distribution system	20
4.1	Five distribution substation configurations (a: single bus, b: sectionalized single bus, c: breaker-and-a-half, d: double bus double breaker, e: ring bus)	23
4.2	Single line diagram of link arrangement system	31
4.3	Single line diagram of basic radial system	31
4.4	Single line diagram of open loop system	32
4.5	Single line diagram of closed loop system	33
4.6	Single line diagram of primary network system	33
4.7	Comparison of failure rates for five composite distribution systems	43
4.8	Comparison of unavailability for five composite distribution systems	44
4.9	Comparison of system reliability indice (SAIFI) for five distribution system	47
4.10	Comparison of system reliability indice (SAIDI) for five distribution system	48
4.11	Comparison of system reliability indice (CAIDI) for five distribution system	48
4.12	Comparison of system reliability indice (AENS) for five distribution system	49
5.1	Power flow direction of substation configuration 'a' (a: when either T2 or B4 are out of service, b: when either T1 or B3 are out of service)	52

5.2	Fault tree diagram of reliability analysis for substation configuration 'a'	54
5.3	Power flow direction of substation configuration 'b' (a: when either T2 or B4 are out of service, b: when either T1 or B3 are out of service)	56
5.4	Fault tree diagram of reliability analysis for substation configuration 'b'	57

List of Tables

4.1	Reliability data of substation component	24
4.2	Failure rates due to secondary overlapping failure mode	28
4.3	Unavailability due to secondary overlapping failure mode	29
4.4	Calculation Results of Reliability Indices for Five Substation Configurations (Ignoring Submission Transmission)	30
4.5	Reliability for five substation configurations (including subtransmission failure)	37
4.6	Reliability for five substation configurations (ignoring subtransmission failure)	37
4.7	Failure rates ($\lambda_{LP,i}$) of load points at feeder F2	42
4.8	Unavailability ($U_{LP,i}$) of load points at feeder F2	43
4.9	Customer Data of Feeder F2	46

Chapter 1

Introduction

1.1 Background

The society of the current world is utilizing the electric power as the basic needs for daily life as well as commercial uses. The electricity demand is increasing days by days and the reliability of the electric power supply has become an important factor to fulfill customer expectation without affecting the economic benefits of power companies. Although the reliability of the electric power system can be increased by making more investment, this can lead to more risks to the power companies to get the profits from the investment. On the other hand, low investment can also cause the low reliability and interruptions to the load points which may affect the customer expectations. Due to these reasons, it is necessary to find the optimal condition between the reliability and the economic constraints for the power system.

As substations have an important role in the electric power system and the significant impact on supplying adequate electricity to the customers with least interruptions, the reliability study of substation and distribution system has been conducted in this thesis. The substation has different configurations. The substation reliability is evaluated for five different substation configurations to compare the design pros and cons in terms of reliability point of view.

For the composite distribution system, the RBTS Bus 4 is selected and modified into five different distribution system models that can be applied to both radial type and non-radial type distribution system.

The minimal cut set method has been used for the reliability assessment of substation configurations and its impact on composite distribution system. Using minimal cut set method, the weak links of the system can be identified [1] and the failure probability of the

system can be calculated from the minimal cut sets obtained. Depending on the failure mode of each component,

1.2 Scope

In the first part of the thesis works, the failure rates, outage duration and unavailability of five different substation configurations are analyzed by using same data and the minimal cut set method based on the existing research paper [2]. The interaction between the distribution substation and primary distribution system are also investigated and the reliability of composite distribution system are evaluated including the effect of substation reliability. The composite distribution system has been constructed from RBTS Bus 4 [3] as well as the reliability data, customer data and loading data for the analysis.

In the second part of the thesis, the fault tree analysis is applied to evaluate the same substation configurations to provide the alternative approach and to compare the two methods for reliability evaluation of the substation and composite distribution system.

1.3 Thesis Outline

Chapter 1 - *Introduction*, provides the brief description for the thesis work conducted and introduces the methods used for the reliability assessment of substation and composite distribution system.

Chapter 2 - *Literature Study*, explains the brief overview of reliability test system, reliability assessment methodologies related to distribution substation and composite distribution system.

Chapter 3 - *Reliability Theory and Substation Structures*, introduces a basic concepts of power system reliability, terms and definitions of reliability indices used and substation configurations related to this project work.

Chapter 4 – *Case Study: Utilizing Minimal Cut Set Approach for Substation and Composite Distribution System Reliability*, gives a detailed calculations of substation reliability and distribution system reliability using minimal cut set method.

Chapter 5 - *Case study: Utilizing Fault Tree Analysis for Substation Reliability*, present the investigation of alternative approach to evaluate the substation reliability and compare the results with respect to the results obtained by using minimal cut set method.

Chapter 6 – *Conclusions and Future Works*, gives a review of the project works done in this thesis, describes limitations and suggestions for future works.

Chapter 2

Literature Study

In this chapter, the literature study for reliability evaluation methodologies related to the power system, especially substation and distribution are presented briefly to have a general overview in this research area. The minimal cut set method and fault tree analysis (FTA) method are also introduced in this section for the readers to be familiar with the background knowledge of this thesis work.

2.1 Overview on Reliability Test System

Electrical power plays an essential role in this modern world. The electricity usage of today's society has also been increasing greatly year by year. The reliable electricity supply has become an important part of the electric power system concerning with the mutual benefits of power companies and the customers. As the reliability level of the power system is directly increased with the investment cost of the facilities, the optimal balance between the reliability level and economic constraints are needed to be found out. Therefore, many researches have been done in power system reliability (PSR) for the reliability evaluation of generation facilities, transmission facilities and distribution facilities. *Reliability evaluation of a complete electric power system including generation, transmission, station and distribution facilities is an important ability in overall power system planning and operation* [1][4]. But overall power system reliability evaluation is not usually performed due to the high complexity level of the system. Instead, the reliability evaluation of generation facilities, transmission facilities and distribution facilities are conducted independently [4][1][5]. *Since distribution systems account for up*

to 90% of all customer reliability problems, improving distribution reliability is the key to improving customer reliability [5].

For research purposes of the reliability evaluation of the power system, IEEE Reliability Test System (RTS) was developed by the Application of Probability Method (APM) Subcommittee in 1979 [6]. As IEEE-RTS is composed of the relatively large power system network, a basic reliability test system was developed from the reliability education and research program conducted by the Power System Research Group at the University of Saskatchewan and designed as the Roy Billinton Test System (RBTS) [3][4][7][8]. In this thesis, the composite distribution system is taken from RBTS Bus 4 [3] and modified into five different primary distribution systems [2].

2.2 Overview on Reliability Evaluation Methods

Basically, power system reliability assessment can be categorized into two aspects such as deterministic and probabilistic [9]. Deterministic method uses the reserve margin and the largest set in the system as the reliability indices in which the stochastic system behavior is not included [9]. The probabilistic method considers the dynamic system behavior such as faults, component failures, and so on for the reliability assessment of the power system [9]. It can be subdivided into two methods such as analytical method and simulation method. In the simulation method, Monte Carlo (MC) simulation is extensively used to estimate the system reliability and availability for large systems [10][11][12][13]. Analytical method develops the mathematical models for the system and conduct the numerical analysis to evaluate the system performance [9].

Commonly used analytical methods for power system reliability studies (PSR) including distribution substation and composite distribution system reliability assessment are minimal cut set method [14,15,16,17,18,19], fault tree analysis (FTA) [20,21,22,23,24], event tree analysis (ETA) [25,26], Reliability Block Diagram (RBD) [26,27,28,29] and Markov Modelling (MM) [26,30,31].

Among these methods, the event tree analysis (ETA) is used in only for the reliability analysis of protection system of PSR. Reliability Block Diagram (RBD) and Markov Modelling (MM) are widely utilized for the reliability analysis of distribution substation

and distribution system. Although Markov Modelling (MM) is a powerful tool for reliability assessment of transmission system and distribution system, it is very complex to construct the state transition matrix for the large system and requires deep background understanding to be utilized. RBD is simpler to be used and similar to fault tree analysis [46]. But RBD is needed to be accessed completely when some changes are made in the system arrangement. In comparison with these methods, fault tree analysis (FTA) requires less computation time and include cause-effect relation [22]. Minimal cut set method is also extensively used in the reliability studies due to its advantages to show all possible causes of system failures with respect to the failure modes of each component [20]. Therefore, minimal cut set method and fault tree analysis are selected for the reliability assessment of distribution substation and distribution system in this thesis.

2.2.1 Overview of Minimal Cut Set Method

Minimal cut set method is often used in the reliability assessment of distribution substation and distribution system. In literature [2][14], the reliability indices of the five substation configurations (single bus, sectionalized single bus, breaker-and-a-half, double breaker double bus and ring bus) are evaluated by using minimal cut-set method based on the criterion of continuity of service. In [14], only the failure rate calculation for single bus configuration is described as an example. In [2], the calculation procedure for the reliability indices of five substation configurations have explained but no calculation has been described in the research paper. In [15], the impact of protection system on power system reliability is analyzed by using minimal cut set method and many sample calculations have explained clearly throughout the report. In [16], the reliability of different substation configurations (including five substation configurations described in [2,14]) is analyzed by Power System Simulator for Engineering (PSS/E) and the reliability indices are calculated by minimal cut set methods. But stuck breaker condition is considered only in single bus configuration. In [17], composite system reliability analysis of ring bus configuration has been conducted by using minimal cut set. No calculation has been made for the minimal cut sets in the research paper. In [18], a sectionalized bus configuration has been analyzed by using minimal cut set method. The failure modes of each component has been considered and explained thoroughly. The failure rate

calculations for the minimal cut sets can be conducted by using the equations described in [18]. But nothing is explained to calculate the unavailability of the each cut sets and no detailed calculation has been made. In [19], a sectionalized bus configuration is analyzed to get the reliability indices by using minimal cut set to illustrate the substation-related outages in transmission system reliability. No sample calculations of the minima cut sets are presented in this literature.

2.2.2 Overview of Fault Tree Analysis (FTA)

Fault tree analysis has been utilized for the reliability assessment of power system such as generation and transmission facilities, distribution system and distribution substation especially related to the protective systems. FTA can provide simple cause and effect relation of system failures to determine the system reliability level.

In literature [20], reliability analysis of two substation configurations such as one-and-a-half breaker type and double breaker type are conducted by using fault tree analysis. The fault trees for these two substation configurations are constructed according to the power flow direction. The method is based on the energy delivery from source point to load point. SUBREL and RISKSPECTRUM simulation software are used for the analysis which are very expensive for the individual researcher.

In literature [21] and [23], fault tree analysis is used for the assessment of power system reliability and distribution system reliability respectively. In [21], fault tree construction is illustrated only for the part of the system and no detailed calculations has been described. In [23], a simple radial type distribution system is considered for the fault tree analysis.

In literature [22], fault tree analysis evaluates the reliability assessment of the protection system such as bus protection, transmission line protection, breaker failure protection, generator backup protection and remote trip failure. Fault trees are constructed based on the component structure rather than power flow direction.

In literature [24], the reliability of ethernet network topologies in substation control and monitoring networks are compared by using fault tree analysis. In this case, the fault tree construction includes the effect of the component availability whereas other fault tree

analysis in [20,21,22,23] does not consider this impact on the fault tree construction. Reliability assessment by fault tree analysis has not been compared with other methods such as minimal cut set in the literature. The motivation of this thesis work is to investigate whether these fault tree approaches can be used to get the same reliability assessment.

Chapter 3

Reliability Theory and Substation Structures

In the previous chapter, the literature study for reliability evaluation methodologies related to the power system, especially substation and distribution system have discussed briefly to cover general understanding of methodologies in this research area. The main objective of the project work is to evaluate reliability of different substation configurations and the impact of its reliability over distribution system reliability. This section gives the theoretical background for reliability concepts and introduces the reliability indices used in this thesis. Five commonly used substation configurations are also discussed in terms of their structures and operations. As RBTS bus 4 is utilized as composite distribution test system, a brief description of RBTS Bus 4 is also explained.

3.1 Basic Reliability Concept

The term 'reliability' has a variety of meanings. Reliability of a power system refers to *the probability of its satisfactory operation over the long run. It denotes the ability to supply adequate electric service on a nearly continuous basis, with few interruptions over an extended time* [32]. In the power system studies, it can be categorized into two domains such as *system adequacy and system security* [1] [32].

The system adequacy is related to the static reliability of the power system in which the system design structure and installed capacity are more focused for the evaluation of the reliability of the system without considering the system dynamic behavior [32].

The system security is related to the dynamic reliability of the power system in which the transient disturbances such as short circuit faults, unexpected failure system components are taken into consideration [32].

Reliability evaluation of the power system can be categorized in terms of three function zones such as generation, transmission and distribution [1] and these functional zones in series can be considered as the hierarchical levels of the power system reliability studies as shown in Fig. 3.1 which is adapted from [1].

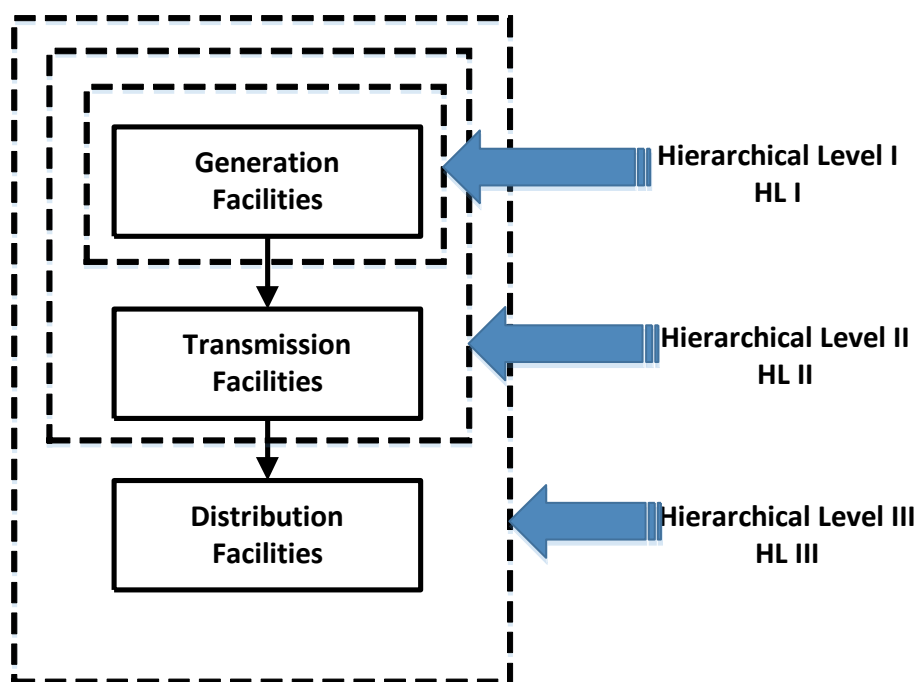

Fig. 3.1 Functional zones and hierarchical levels of a power system [1]

Hierarchical level I is related to the generation facilities only. Hierarchical level II is composed of generation and transmission facilities and known as *the composite generation and transmission (bulk power) system and its ability to deliver energy to the bulk supply points* [1]. Hierarchical level III includes all of the three functional zones (generation, transmission and distribution facilities) and refers to as *the complete electric power system* [1]. Due to the enormous complexity of the power system, the reliability of HL I and HL II are evaluated whereas the HL III is not conducted for the reliability analysis. Instead, the reliability evaluation of the distribution system is conducted independently [1][4][33].

3.2 Terms and Definitions of Reliability Indices

Reliability evaluation of HL III includes all three functional zones of the power system in the overall assessment of customer load point reliability. The basic reliability indices of HL III includes the average failure rate (λ), average outage duration (r) and the annual unavailability (U) at the consumer load points. These basic reliability indices of each load point can be utilized together with number of customers at each load point to calculate the overall system reliability indices such as the system average interruption frequency index (SAIFI), the system average interruption duration index (SAIDI), the customer average interruption duration index (CAIDI) and the average service availability index (ASAI). The terms and definitions of the basic reliability indices and system reliability indices are described below.

3.2.1 Basic Reliability Indices

Failure rate (λ) refers to the number of failure that the component or the system has occurred during the studied period [25]. In this study, the failure rate is measured by failures per year (f/yr).

$$\lambda = \frac{\text{Number of failures}}{\text{Studied periods} \times (\text{circuit lengths for transmission lines or cables})} \quad (3.1)$$

Mean Time to Repair (MTTR) refers to the average time taken to identify the location of failure of a component or the system and to repair that failure [25]. MTTR is also known as repair time (r). MTTR is usually measured by hour.

The expected repair rate (μ) is the reciprocal of the mean time to repair (MTTR).

$$\mu = \frac{1}{MTTR} \quad (3.2)$$

The forced outage duration (FOR) or unavailability (U) of the component or the system refers to the average duration the component or the system is not operating over the studied period [25]. The dimension of this unavailability is hours per year or minutes per year. The unit unavailability can be calculated as follows.

$$U = \frac{\lambda}{\lambda + \mu} \quad (3.3)$$

Availability (A) of the component or the system refers to the average duration that the component or the system is operating over the studied period [25]. The dimension of this availability is hours per year or minutes per year. The unit availability can be calculated as follows.

$$A = \frac{\mu}{\lambda + \mu} \quad (3.4)$$

3.2.2 System Reliability Indices

The three reliability indices (expected failure rate, expected outage duration and average annual unavailability) described above are basically needed to represent the reliability of the system. But these indices cannot represent the complete system behavior related to the reliability analysis. Additional reliability indices are needed to be evaluated to represent the severity or significance of the system behavior. The commonly used system reliability indices can be defined as follows which are adapted from [1].

System average interruption frequency index, SAIFI, refers to the ratio of the total number of customer interruptions to total number of customers served and is measured by interruptions/customer.yr [1].

$$SAIFI = \frac{\sum \lambda_i N_i}{\sum N_i} \quad (3.5)$$

where λ_i is the failure rate and N_i is the number of customers of load point i.

System average interruption duration index, SAIDI, refers to the ratio of the sum of customer interruption durations to total number of customers and usually measured by hr/customer.yr [1].

$$SAIDI = \frac{\sum U_i N_i}{\sum N_i} \quad (3.6)$$

where U_i is the annual unavailability and N_i is the number of customers of load point i.

Customer average interruption duration index, CAIDI, refers to the ratio of the sum of customer interruption durations to total number of customer interruptions and its dimension is hr/customer interruption [1].

$$CAIDI = \frac{\sum U_i N_i}{\sum \lambda_i N_i} \quad (3.7)$$

where λ_i is the failure rate, U_i is the annual unavailability and N_i is the number of customers of load point i.

Average energy not supplied, AENS can be defined as the ratio of the total energy not supplied to the total number of customers served and is measured by kWh/customer.yr [1].

$$AENS = \frac{\sum L_{a(i)} U_i}{\sum N_i} \quad (3.8)$$

where $L_{a(i)}$ is the average load connected to the load point i, U_i is the annual unavailability and N_i is the number of customers of load point i.

3.3 Substation Structures

Substation is one of the important part of the power system to transfer reliable electricity to the customer adequately. It is also an interface where voltages are transformed from higher voltage level to lower voltage level or vice versa either between the generation and transmission systems or between the transmission and sub-transmission systems or between the sub-transmission systems and distribution systems [34][37]. The reliability of substation has great impact on the overall reliability of the power system and can be measured in terms of the frequency and duration of substation-related equipment outage events that violates the system reliability criteria such as equipment overloads or unacceptable voltages [34][35].

Based on the bus bar and circuit breaker installation arrangements, there are 6 commonly used substation configurations [14][15][35][37][37] as described below.

- Single bus - single breaker,
- Double bus - single breaker with bus-coupler,
- Main and Transfer Bus,

- Double bus - breaker and a half,
- Double bus - double breaker, and
- Ring bus or four breaker mesh.

Among these six substation configurations, the main and transfer bus configuration is not discussed in this section and the other five configurations are selected for the reliability analysis [35]. The operation and structures of these five substation configurations are described in following subsections [35].

3.3.1 Single Bus – Single Breaker Configuration

Single bus single breaker configuration consists of only one bus for all incoming lines and outgoing lines as shown in Fig. 3.2 [35]. Any fault occurred on the busbar, circuit breakers or the link between the busbar and circuit breaker will cause the entire substation outage. For maintenance operation of circuit breaker, a bypass switch can be installed across the circuit breaker but this will disable the protection system of the maintenance line [35]. On the other hand, the entire substation is needed to shut down to conduct maintenance operation of the bus in this configuration [35].

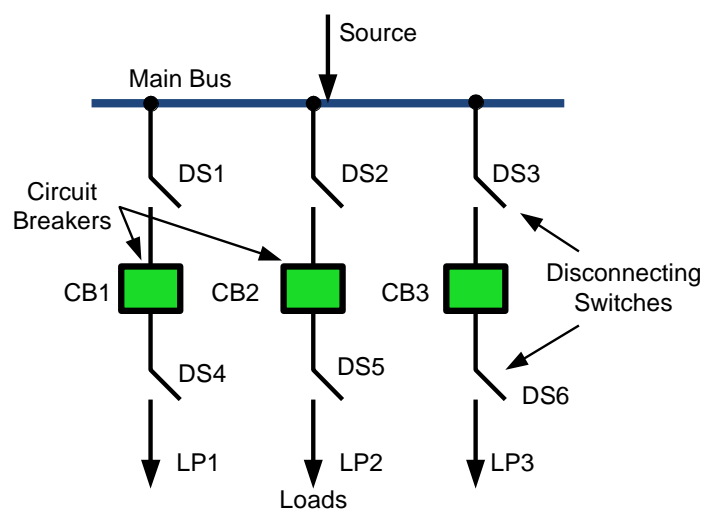

Fig. 3.2 Simplified single bus single breaker configuration [20][35]

The advantages of single bus single breaker configuration is simple in structure, requires less space and least cost due to fewer components and substation expansion can be easily done [14][35][36]. But The disadvantages of single bus configuration are lowest reliability, complicated maintenance switching and outage of entire substation due to even single failure [14][35][36].

3.3.2 Double bus – Single Breaker with Bus Coupler Configuration

This substation configuration consists of two bus with bus coupler circuit breaker (CB3) as shown in Fig. 3.3 [35]. When this circuit breaker is closed, all the lines can be connected to either of the bus. When a fault occurs on one of the bus, faulted bus is isolated [35]. The lines connected to the faulted bus can be fed from the other healthy bus [35]. The breaker bypass operation can be conducted without disabling the protection of the whole corresponding line [35].

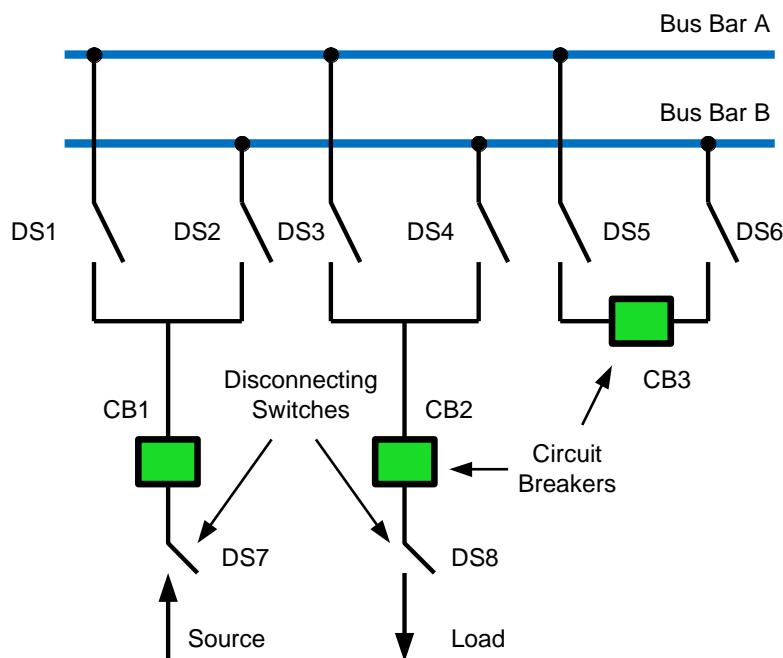

Fig. 3.3 Simplified double bus single breaker with bus couplers configuration [35][37]

Its advantages over single bus configuration are the higher reliability, flexibility in operation, isolation of bus section for maintenance operation and only faulted part isolation due to bus bar fault or circuit breaker failure [14][35][36]. The disadvantages are higher cost, more space requirement and interruption of non-faulted circuits due to sectionalizing [14][35][36].

3.3.3 Double Bus – A Breaker-And-A-Half Configuration

This substation configuration consists of two main buses (busbar A and busbar B) and three circuit breakers (for example, CB1, CB2 and CB3) are required for every two circuits while each circuit shares the common circuit breaker (CB2) as shown in Fig 3.4 [35]. Any of the breaker can be opened and removed for repair or maintenance without service

interruption of the corresponding circuit. If a fault happens on either of the bus, it is isolated without affecting the service to the outgoing lines [35].

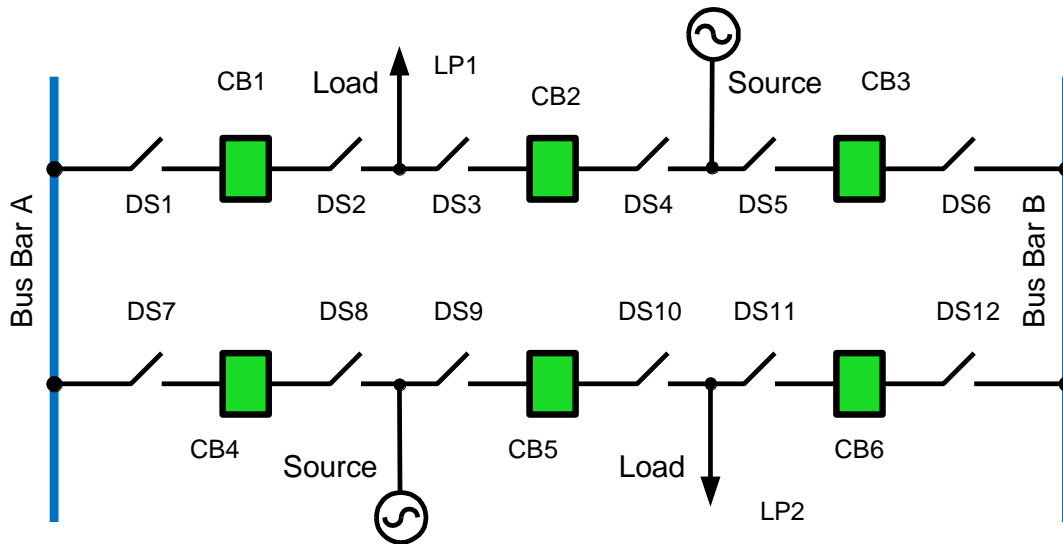

Fig. 3.4 Simplified double bus a-breaker-and-a-half configuration [20][35]

The advantages of the breaker and a half configuration are as follows [14][35][36].

- High reliability
- Flexibility in operation and maintenance
- Isolation of either bus or any circuit breaker for maintenance without service interruption
- Double fed to each circuit
- All switching with circuit breakers

The disadvantages of the breaker and a half configuration are as follows [14][35][36].

- Should have separate source for relaying
- Costlier as one and a half circuit breaker is needed for each circuit
- Complicated relaying scheme as the middle breaker is associated with both circuits

3.3.4 Double Bus – Double Breaker Configuration

This substation configuration also consists of two energized buses (busbar A and busbar B). However, in the double breaker configuration, two circuit breakers (e.g. CB1 and CB2) are needed for each circuit as shown in Fig. 3.5 [35]. If any failure of a circuit breaker happens, it will only affect one circuit. A fault on either bus or a circuit breaker can also be isolated without service interruption of the outgoing lines [35]. The double breaker

arrangement has advantages over breaker and half configuration such that only one circuit will be interrupted due to the circuit breaker failure [14][35][36]. All the remaining aspects are as good as a-breaker-and-a-half scheme [14][35][36]. As the number of components used for each circuit has increased, the cost is higher than breaker and a half configuration [14][35][36].

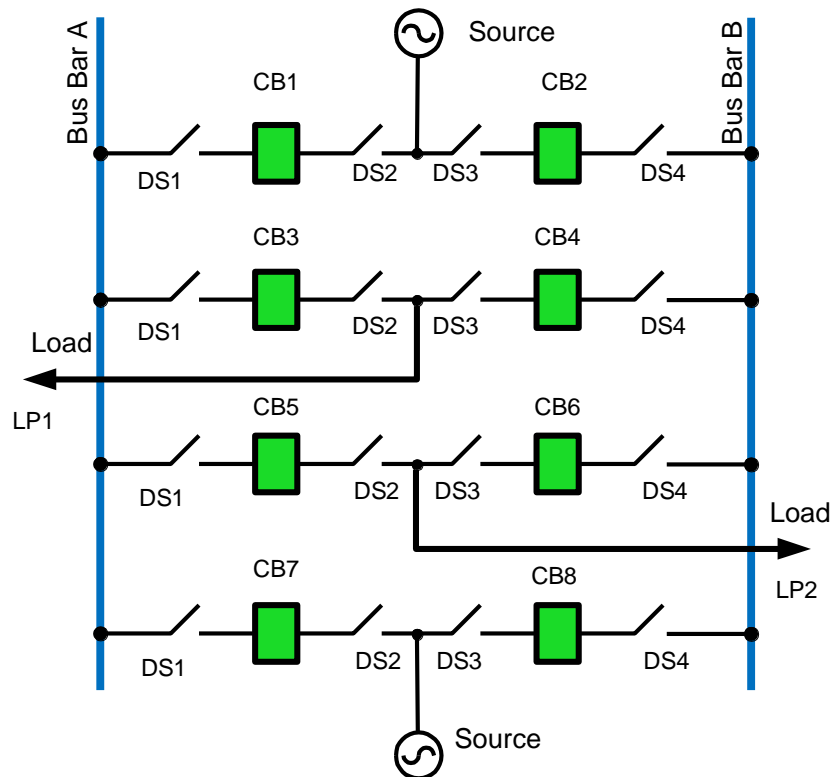

Fig. 3.5 Simplified double bus double breaker configuration [20][35]

3.3.5 Ring Bus Configuration

In the ring bus configuration, the circuit breakers connected as a ring shape and each circuit is terminated between two circuit breakers as shown in Fig. 3.6 [35]. The number of circuit breakers is the same as the number of circuits in the ring [35].

The advantages of the ring bus configuration are as follows [14][35][36]:

- High reliability
- Flexibility in operation and maintenance
- Double fed to each feeder circuit
- Isolation of bus section or the breaker without service interruption
- easily expandable to break-and-a-half scheme

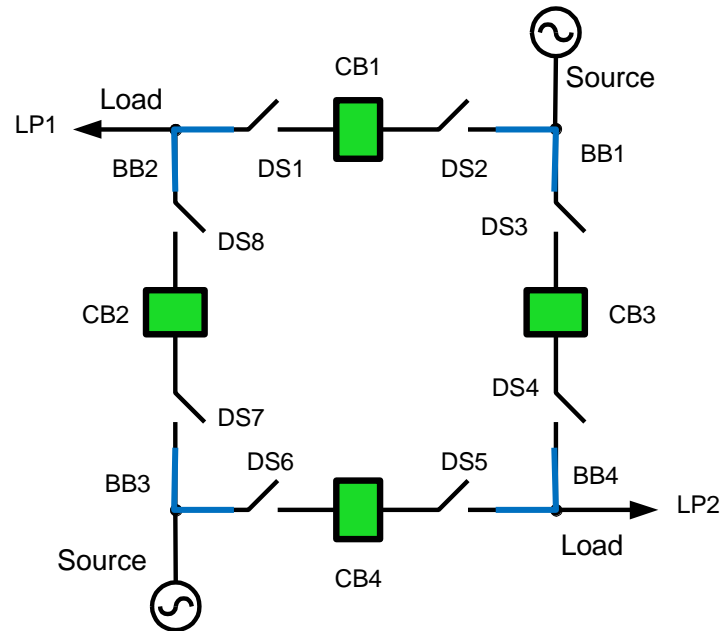

Fig. 3.6 Simplified ring bus configuration [20][35]

The disadvantages of the ring bus configuration are as follow [14][35][36]:

- Undesirable circuit combination because of ring split due to the fault occurrence
- Not suitable for more than 6 circuits

3.4 Composite Test System

Reliability of the power system can be generally understood as the ability of the power system to maintain the continuity of the energy supply to the customer. Continuity of the supply to the customers with the defined standards is the most important factor for the electric power system. Therefore, the reliability assessments of the power system have been focused for the development of the electric power system. Reliability of the power system can be increased by means of redundancy of supply and components, regular maintenance of the components in the system and so on which in turn will also increase the operation and maintenance cost of the system [39]. Test systems have developed to use as a bench mark tool for different kinds of reliability studies in the power systems. Test system have been designed to resemble an actual power system with limited complexity but sufficiently in general to conduct various kinds of reliability studies related to the power system. In the power system reliability (PSR), IEEE RTS (IEEE Reliability Test System) and RBTS (Roy Billinton Test System) have been used widely by researchers in this filed to analyze the reliability evaluation of the power system [39].

IEEE RTS was firstly introduced and published in 1979 which is referred to as RTS-79 and the second version of IEEE RTS developed in 1986 which is referred to as RTS-86 [40]. The original IEEE RTS have been modified steps by steps and developed as RTS-96 to cover for the different evaluation methodologies and to compensate deficiencies [40]. The IEEE RTS is composed of 24 buses, 32 generators with total installed capacity of 3405 MW and 32 loads with a total peak load of 2850 MW. On the other hand, RBTS was designed and created by the research group at the University of Saskatchewan [3][4][8].

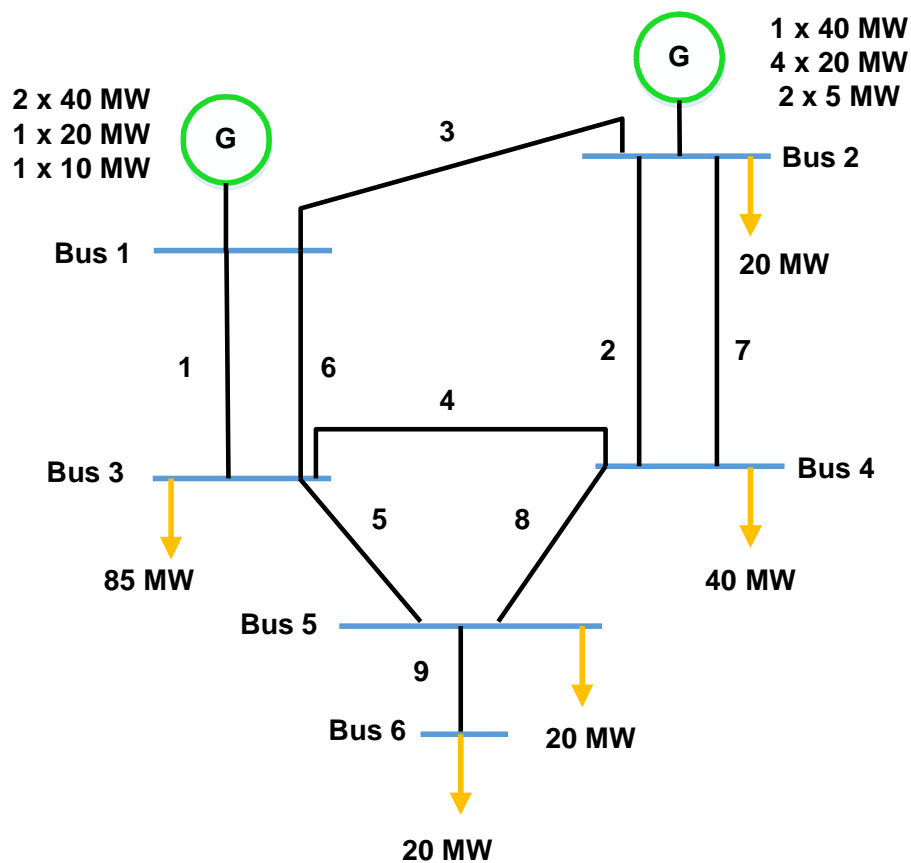

Fig. 3.7 Single line diagram of RBTS [8]

The main object of designing RBTS [8] is “to make it sufficiently small to permit the conduct of a large number of reliability studies with reasonable solution time but sufficiently detailed to reflect the actual complexities involved in a practical reliability analysis”. In comparison with IEEE RTS, RBTS has 6 buses, 9 transmission lines and 11 generating units with total installed capacity of 240 MW and a system peak load of 185 MW [8]. As RBTS is a smaller composite test system with respect to IEEE RTS and is suitable for distribution system reliability analysis, the composite distribution system reliability

evaluation has been conducted on RBTS. The single line diagram of RBTS is described in Fig. 3.7.

3.4.1 RBTS Bus 4 Distribution Test System

The RBTS has 5 load busbars (Bus 2 to Bus 6 as shown in Fig. 3.7). Bus 4 is selected to conducted the composite distribution reliability evaluation in this thesis. The single line diagram of the RBTS Bus 4 is described in Fig. 3.8. The peak loads, feeder types and lengths, customer data, load data, and reliability and system data of RBTS Bus 4 is described in Appendix A. RBTS Bus 4 is composed of three substations with 38 load points. Bus 4 distribution test system is supplied by six 33/11 kV, 16 MVA transformers. Distribution of the electric supply to the customer sides is conducted from the 11kV busbar. The customers at the different load points are supplied by either 11/0.415 kV transformers or 11kV busbar itself directly. The following assumptions has been made for the reliability study of the Bus 4 distribution test system in this thesis which are adopted from the reference [31].

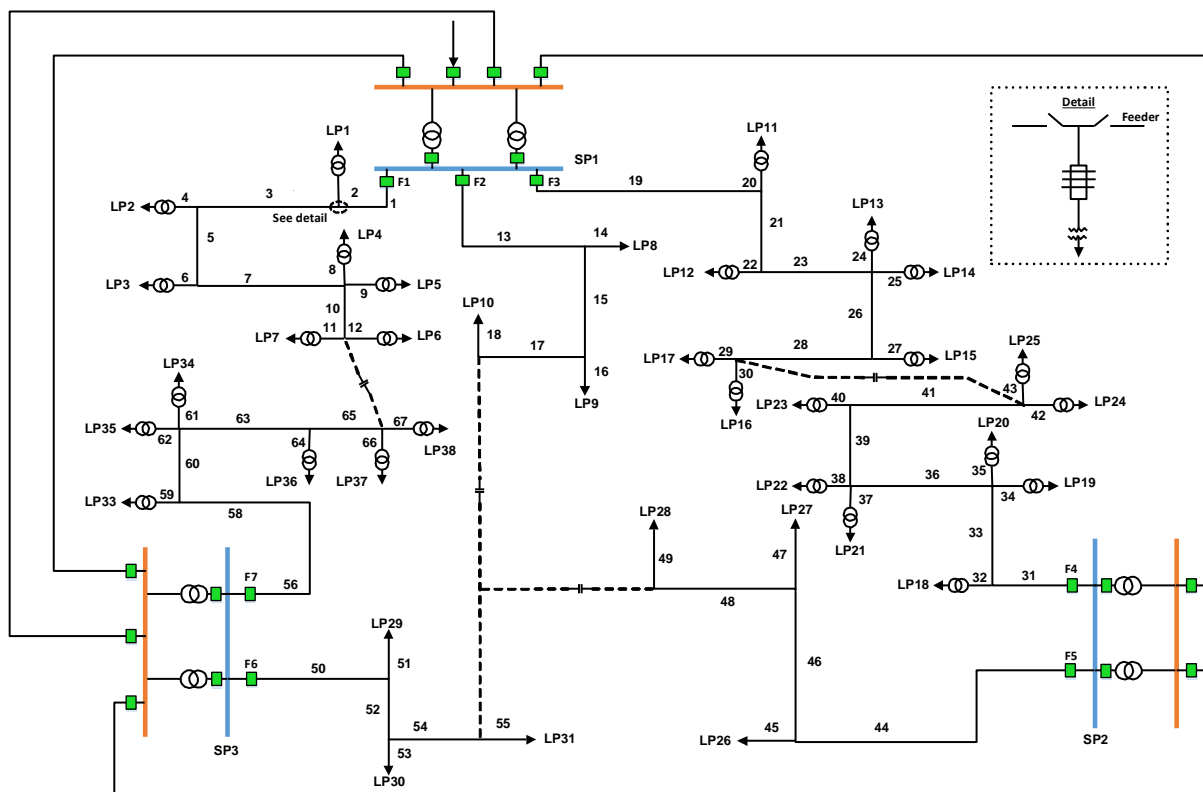

Fig. 3.8 Single diagram of RBTS Bus 4 distribution system [3]

The feeders (F1 to F7) are working as radial types but the connections between the feeders are also made as a mesh by normally open sectionalizing points [3].

The ring network among the three supply points (SP1, SP2 and SP3) allows the normally open sectionalizing points to be activated when the fault occurs and provide the alternative supply points for the customers [3].

33 kV ring network connecting the three supply points (SP1, SP2 and SP3) justify the loading level of Bus 4 (40MW) sufficiently [3].

All circuit breakers in the Bus 4 distribution test system are identified [3].

All the 11kV main feeder sections and lateral sections are considered as overhead lines, not as cables [3].

The lengths of the 11kV main feeder section and lateral sections has three types such as 0.6, 0.75 or 0.8 km as shown in Table A.2 [3].

The disconnectors and fuses connected at the main feeder sections and lateral sections are assumed to be 100% reliable [3].

The 11/0.415kV transformers are assumed to be replaced whenever failure of transformer has occurred [3].

Chapter 4

Case Study: Utilizing Minimal Cut Set Approach for Substation and Composite Distribution System Reliability

The theoretical background and required knowledge related to the reliability evaluation of substation configurations and composite distribution system have been discussed in the previous chapters. This section will describe the detailed calculations of the substation reliability by using minimal cutset method. Five different substation configurations which are adapted from reference [14][2] are analyzed to evaluate the substation reliability. In these research papers, only the concepts of reliability indices calculation are explained and no detailed calculations have not been conducted. From the literature study, it has found that most of the research papers have also discussed the concepts of reliability evaluation of substation reliability and composite distribution system reliability by using minimal cut set without describing the detailed calculation steps or program codes. This can lead to much confusions and face many difficulties for the student researchers who start doing research in this field. The motivation of this thesis is to provide the clear illustration of detailed calculations for substation reliability as well as composite distribution system reliability. For the composite distribution system, the RBTS Bus 4 system is taken and modified into five different types of distribution systems. Peak loads, feeder types and lengths, customer data, loading data and the reliability and system data are taken from the reference [3].

4.1 Substation Reliability

The reliability of distribution substation has significant impact on supplying electricity and energy to the customers adequately with the specified standards. Substation failure can lead to power interruptions at all load points. Various substation configurations can have different reliability levels and needed to investigate to find the optimal balance between reliability requirements of the customers and economic constraints of the power companies. The life cycle cost (LCC) calculation [16] of substation configuration is not included in this thesis.

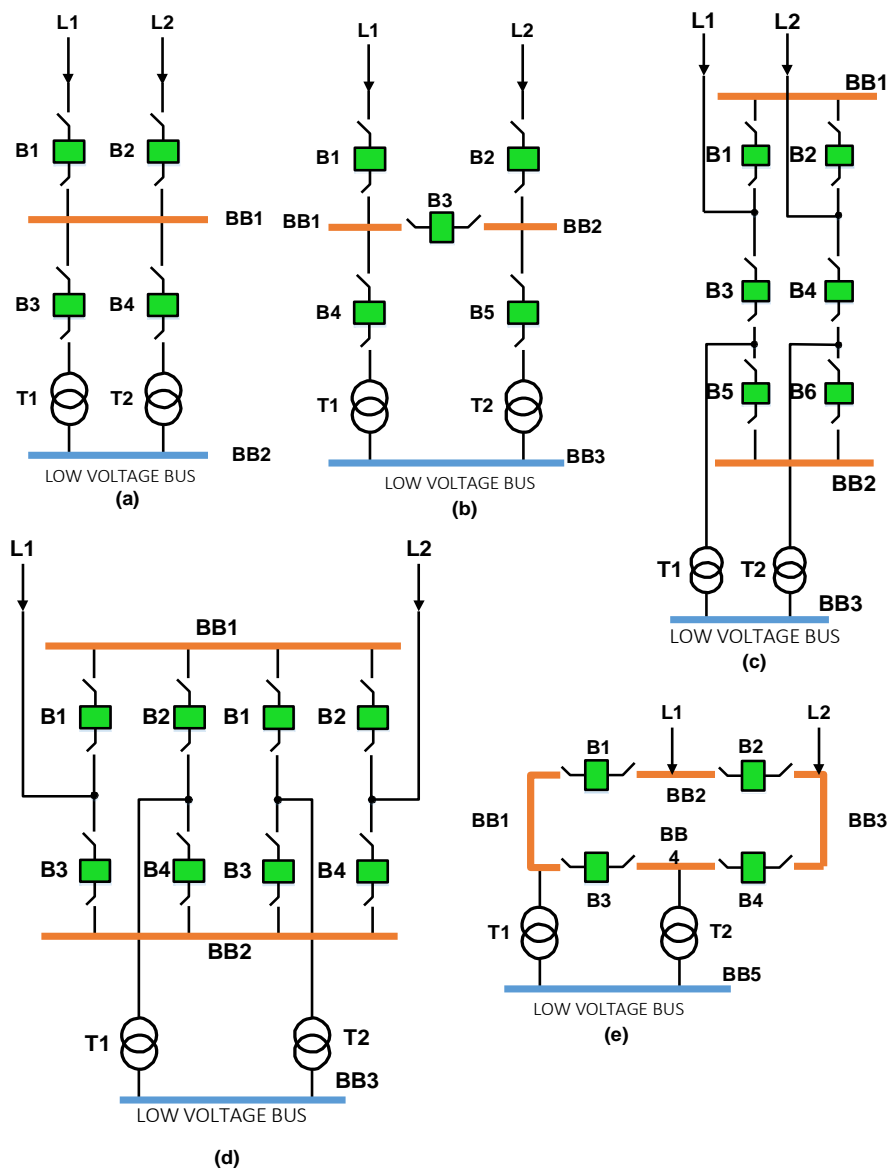

Fig. 4.1 Five distribution substation configurations (a: single bus, b: sectionalized single bus, c: breaker-and-a-half, d: double bus double breaker, e: ring bus) [2][14]

The basic reliability indices of five different substation configuration such as single bus configuration, sectionalized single bus configuration, double bus a breaker-and-a-half configuration, double bus double breaker configuration and ring bus configuration are evaluated to compare the reliability level of these configuration. These five substation configurations composed of busbars, circuit breakers, disconnectors and step down transformer as shown in Fig. 4.1 [2][14].

Reliability data of substation components are described in Table 4.1 which is adapted from reference [2][3][14].

Table 4.1: Reliability data of substation component, adapted from [2][3][14]

Components	λ_T (f/yr)	λ_A (f/yr)	λ_M (f/yr)	MTTR (hours)	MTTM (hours)	P_c	s (hours)
Line	0.065	0.065	0.5	5	8	0	1
Transformer	0.015	0.015	1	15	120	0	1
Breaker	0.006	0.004	1	4	96	0.05	1
Bus bar	0.001	0.001	0.5	2	8	0	1

The following assumptions are made to calculate the reliability indices of five different types of distribution substations [2].

- *Disconnectors are 100% reliable and not include in the calculation [3]*
- *Failure modes considered for the minimal cut sets are first order failure (including both passive failure and active failure), first order active failure, first order active failure with stuck condition of circuit breakers and second order overlapping failure event involving two substation components [2][14]*
- *Higher order failure are not considered due to low probability occurrence [14][20]*
- *Overlapping failure events include active failure or total failure overlapping the total failure or maintenance outage of another component [2][14]*
- *Any subtransmission line or transformer can justify the loading level of all feeders when another subtransmission line or transformer is isolated from the system due to fault occurrence or maintenance purpose [2].*
- *Feeder breakers connected at the outside of substation are not included in this substation reliability calculation [2].*
- *Those feeder breakers will be considered in the reliability calculation of composite distribution system described in next section [2].*

4.1.1 Reliability Indices Calculation for Single Bus Configuration

Assuming the incoming line L1 and L2 are reliable completely [2][14] for simplicity of the case study. The calculation procedure of minimal cut set method is based on the reference [2,14,15,17,18,19,41]. The minimal cut sets due to the failure modes of the substation components can be calculated as follows.

From Fig. 4.1 (a), it can be seen that first order total failure of high voltage bus (BB1) and low voltage bus (BB2) can cause substation failure and the contributions of substation reliability indices by these minimal cut sets can be calculated as follows [2][14].

$$\begin{aligned}\lambda_t &= \lambda_{T(BB1)} + \lambda_{T(BB2)} \\ &= 0.001 + 0.001 = 0.002 \left(\frac{f}{yr} \right)\end{aligned}\quad (4.1)$$

Annual outage time due to the total failure of BB1 and BB2 can also be calculated as follows.

$$\begin{aligned}U_t &= U_{T(BB1)} + U_{T(BB2)} \\ &= \left(\lambda_{T(BB1)} \times MTTR_{BB1} \right) + \left(\lambda_{T(BB2)} \times MTTR_{BB2} \right) \\ &= (0.01 \times 2) + (0.01 \times 2) = 4 \times 10^{-3} \left(\frac{hr}{yr} \right)\end{aligned}\quad (4.2)$$

First order active failures of circuit breaker (CB1, CB2, CB3 and CB4) can cause the substation failure and the contributions of the reliability indices due to circuit breaker first order failures can be calculated as follows [2][14].

$$\begin{aligned}\lambda_a &= \lambda_{A(B1)} + \lambda_{A(B2)} + \lambda_{A(B3)} + \lambda_{A(B4)} \\ &= 0.004 + 0.004 + 0.004 + 0.004 = 1.6 \times 10^{-2} \left(\frac{f}{yr} \right)\end{aligned}\quad (4.3)$$

$$\begin{aligned}U_a &= U_{A(B1)} + U_{A(B2)} + U_{A(B3)} + U_{A(B4)} \\ &= \left(\lambda_{A(B1)} \times S_{B1} \right) + \left(\lambda_{A(B2)} \times S_{B2} \right) + \left(\lambda_{A(B3)} \times S_{B3} \right) + \left(\lambda_{A(B4)} \times S_{B4} \right) \\ &= (0.004 \times 1) + (0.004 \times 1) + (0.004 \times 1) + (0.004 \times 1) = 1.6 \times 10^{-2} \left(\frac{hr}{yr} \right)\end{aligned}\quad (4.4)$$

The contribution of reliability indices due to the first order active failure plus stuck breaker can be calculated in which PC is assumed to be 1 [14] as follows [2][18].

$$\begin{aligned}\lambda_s &= \lambda_{A(T1)} \times P_{C(B1)} + \lambda_{A(T1)} \times P_{C(B1)} \\ &= 0.015 \times 1 + 0.015 \times 1 = 0.03 \left(\frac{f}{yr} \right)\end{aligned}\quad (4.5)$$

$$\begin{aligned}
U_s &= \lambda_{A(T1)} \times P_{C(B1)} \times s_{T1} + \lambda_{A(T1)} \times P_{C(B1)} \times s_{T2} \\
&= (0.015 \times 1 \times 1) + (0.015 \times 1 \times 1) = 0.03 (\text{hr}/\text{yr})
\end{aligned} \tag{4.6}$$

The total failures overlapping total failures of (B1+B2), (B3+B4), (B3+T2), (B4+T1) and (T1+T2) can cause substation failure and the failure rates contributed by these minimal cutsets can be calculated by using equation (4.7), (4.8), (4.9), (4.10) and (4.11) respectively [2][14].

$$\lambda_{B1+B2} = \frac{\lambda_{T(B1)} \times e^{-\lambda_{T(B1)}} + \lambda_{T(B2)} \times e^{-\lambda_{T(B2)}} - (\lambda_{T(B1)} + \lambda_{T(B2)}) \times e^{-(\lambda_{T(B1)} + \lambda_{T(B2)})}}{e^{-\lambda_{T(B1)}} + e^{-\lambda_{T(B2)}} - e^{-(\lambda_{T(B1)} + \lambda_{T(B2)})}} \tag{4.7}$$

$$\lambda_{B3+B4} = \frac{\lambda_{T(B3)} \times e^{-\lambda_{T(B3)}} + \lambda_{T(B4)} \times e^{-\lambda_{T(B4)}} - (\lambda_{T(B3)} + \lambda_{T(B4)}) \times e^{-(\lambda_{T(B3)} + \lambda_{T(B4)})}}{e^{-\lambda_{T(B3)}} + e^{-\lambda_{T(B4)}} - e^{-(\lambda_{T(B3)} + \lambda_{T(B4)})}} \tag{4.8}$$

$$\lambda_{B3+T2} = \frac{\lambda_{T(B3)} \times e^{-\lambda_{T(B3)}} + \lambda_{T(T2)} \times e^{-\lambda_{T(T2)}} - (\lambda_{T(B3)} + \lambda_{T(T2)}) \times e^{-(\lambda_{T(B3)} + \lambda_{T(T2)})}}{e^{-\lambda_{T(B3)}} + e^{-\lambda_{T(T2)}} - e^{-(\lambda_{T(B3)} + \lambda_{T(T2)})}} \tag{4.9}$$

$$\lambda_{B4+T1} = \frac{\lambda_{T(B4)} \times e^{-\lambda_{T(B4)}} + \lambda_{T(T1)} \times e^{-\lambda_{T(T1)}} - (\lambda_{T(B4)} + \lambda_{T(T1)}) \times e^{-(\lambda_{T(B4)} + \lambda_{T(T1)})}}{e^{-\lambda_{T(B4)}} + e^{-\lambda_{T(T1)}} - e^{-(\lambda_{T(B4)} + \lambda_{T(T1)})}} \tag{4.10}$$

$$\lambda_{T1+T2} = \frac{\lambda_{T(T1)} \times e^{-\lambda_{T(T1)}} + \lambda_{T(T2)} \times e^{-\lambda_{T(T2)}} - (\lambda_{T(T1)} + \lambda_{T(T2)}) \times e^{-(\lambda_{T(T1)} + \lambda_{T(T2)})}}{e^{-\lambda_{T(T1)}} + e^{-\lambda_{T(T2)}} - e^{-(\lambda_{T(T1)} + \lambda_{T(T2)})}} \tag{4.11}$$

The unavailability due to above minimal cut sets can be calculated by using equations (4.12), (4.13), (4.14), (4.15) and (4.16) respectively.

$$U_{B1+B2} = \lambda_{B1+B2} \times \frac{MTTR_{(B1)} \times MTTR_{(B2)}}{MTTR_{(B1)} + MTTR_{(B2)}} \tag{4.12}$$

$$U_{B3+B4} = \lambda_{B3+B4} \times \frac{MTTR_{(B3)} \times MTTR_{(B4)}}{MTTR_{(B3)} + MTTR_{(B4)}} \tag{4.13}$$

$$U_{B3+T2} = \lambda_{B3+T2} \times \frac{MTTR_{(B3)} \times MTTR_{(T2)}}{MTTR_{(B3)} + MTTR_{(T2)}} \tag{4.14}$$

$$U_{B4+T1} = \lambda_{B4+T1} \times \frac{MTTR_{(B4)} \times MTTR_{(T1)}}{MTTR_{(B4)} + MTTR_{(T1)}} \tag{4.15}$$

$$U_{T1+T2} = \lambda_{T1+T2} \times \frac{MTTR_{(T1)} \times MTTR_{(T2)}}{MTTR_{(T1)} + MTTR_{(T2)}} \quad (4.16)$$

In addition to these total failures overlapping total failure minimal cut sets, active failure overlapping total failure (B1(A)+B3), (B1(A)+B4), (B3(A)+B2), (B2(A)+B4), (B1(A)+T2), (B1(A)+T1), (B2(A)+T2) and (B2(A)+T1), can also cause substation failure and contribute to the reliability indices of the distribution substation. the failure rates contributed by these minimal cutsets can also be calculated by using equation (4.17), (4.18), (4.19), (4.20), (4.21), (4.22), (4.23) and (4.24) respectively.

$$\lambda_{B1(A)+B2} = \frac{\lambda_{A(B1)} \times e^{-\lambda_{A(B1)}} + \lambda_{T(B2)} \times e^{-\lambda_{T(B2)}} - (\lambda_{A(B1)} + \lambda_{T(B2)}) \times e^{-(\lambda_{A(B1)} + \lambda_{T(B2)})}}{e^{-\lambda_{A(B1)}} + e^{-\lambda_{T(B2)}} - e^{-(\lambda_{A(B1)} + \lambda_{T(B2)})}} \quad (4.17)$$

$$\lambda_{B1(A)+B4} = \frac{\lambda_{A(B1)} \times e^{-\lambda_{A(B1)}} + \lambda_{T(B4)} \times e^{-\lambda_{T(B4)}} - (\lambda_{A(B1)} + \lambda_{T(B4)}) \times e^{-(\lambda_{A(B1)} + \lambda_{T(B4)})}}{e^{-\lambda_{A(B1)}} + e^{-\lambda_{T(B4)}} - e^{-(\lambda_{A(B1)} + \lambda_{T(B4)})}} \quad (4.18)$$

$$\lambda_{B3(A)+B2} = \frac{\lambda_{A(B3)} \times e^{-\lambda_{A(B3)}} + \lambda_{T(B2)} \times e^{-\lambda_{T(B2)}} - (\lambda_{A(B3)} + \lambda_{T(B2)}) \times e^{-(\lambda_{A(B3)} + \lambda_{T(B2)})}}{e^{-\lambda_{A(B3)}} + e^{-\lambda_{T(B2)}} - e^{-(\lambda_{A(B3)} + \lambda_{T(B2)})}} \quad (4.19)$$

$$\lambda_{B2(A)+B4} = \frac{\lambda_{A(B2)} \times e^{-\lambda_{A(B2)}} + \lambda_{T(B4)} \times e^{-\lambda_{T(B4)}} - (\lambda_{A(B2)} + \lambda_{T(B4)}) \times e^{-(\lambda_{A(B2)} + \lambda_{T(B4)})}}{e^{-\lambda_{A(B2)}} + e^{-\lambda_{T(B4)}} - e^{-(\lambda_{A(B2)} + \lambda_{T(B4)})}} \quad (4.20)$$

$$\lambda_{B1(A)+T2} = \frac{\lambda_{A(B1)} \times e^{-\lambda_{A(B1)}} + \lambda_{T(T2)} \times e^{-\lambda_{T(T2)}} - (\lambda_{A(B1)} + \lambda_{T(T2)}) \times e^{-(\lambda_{A(B1)} + \lambda_{T(T2)})}}{e^{-\lambda_{A(B1)}} + e^{-\lambda_{T(T2)}} - e^{-(\lambda_{A(B1)} + \lambda_{T(T2)})}} \quad (4.21)$$

$$\lambda_{B1(A)+T1} = \frac{\lambda_{A(B1)} \times e^{-\lambda_{A(B1)}} + \lambda_{T(T1)} \times e^{-\lambda_{T(T1)}} - (\lambda_{A(B1)} + \lambda_{T(T1)}) \times e^{-(\lambda_{A(B1)} + \lambda_{T(T1)})}}{e^{-\lambda_{A(B1)}} + e^{-\lambda_{T(T1)}} - e^{-(\lambda_{A(B1)} + \lambda_{T(T1)})}} \quad (4.22)$$

$$\lambda_{B2(A)+T2} = \frac{\lambda_{A(B2)} \times e^{-\lambda_{A(B2)}} + \lambda_{T(T2)} \times e^{-\lambda_{T(T2)}} - (\lambda_{A(B2)} + \lambda_{T(T2)}) \times e^{-(\lambda_{A(B2)} + \lambda_{T(T2)})}}{e^{-\lambda_{A(B2)}} + e^{-\lambda_{T(T2)}} - e^{-(\lambda_{A(B2)} + \lambda_{T(T2)})}} \quad (4.23)$$

$$\lambda_{B2(A)+T1} = \frac{\lambda_{A(B2)} \times e^{-\lambda_{A(B2)}} + \lambda_{T(T1)} \times e^{-\lambda_{T(T1)}} - (\lambda_{A(B2)} + \lambda_{T(T1)}) \times e^{-(\lambda_{A(B2)} + \lambda_{T(T1)})}}{e^{-\lambda_{A(B2)}} + e^{-\lambda_{T(T1)}} - e^{-(\lambda_{A(B2)} + \lambda_{T(T1)})}} \quad (4.24)$$

The unavailability due to above minimal cut sets can be calculated by using equations (4.25), (4.26), (4.27), (4.28), (4.29), (4.30), (4.31) and (4.32) respectively [2][14].

$$U_{B1(A)+B3} = \lambda_{B1(A)+B2} \times \frac{MTTR_{(B1)} \times MTTR_{(B3)}}{MTTR_{(B1)} + MTTR_{(B3)}} \quad (4.25)$$

$$U_{B1(A)+B4} = \lambda_{B1(A)+B4} \times \frac{MTTR_{(B1)} \times MTTR_{(B4)}}{MTTR_{(B1)} + MTTR_{(B4)}} \quad (4.26)$$

$$U_{B3(A)+B2} = \lambda_{B3(A)+B2} \times \frac{MTTR_{(B3)} \times MTTR_{(B2)}}{MTTR_{(B3)} + MTTR_{(B2)}} \quad (4.27)$$

$$U_{B2(A)+B4} = \lambda_{B2(A)+B4} \times \frac{MTTR_{(B2)} \times MTTR_{(B4)}}{MTTR_{(B2)} + MTTR_{(B4)}} \quad (4.28)$$

$$U_{B1(A)+T2} = \lambda_{B1(A)+T2} \times \frac{MTTR_{(B1)} \times MTTR_{(T2)}}{MTTR_{(B1)} + MTTR_{(T2)}} \quad (4.29)$$

$$U_{B1(A)+T1} = \lambda_{B1(A)+T1} \times \frac{MTTR_{(B1)} \times MTTR_{(T1)}}{MTTR_{(B1)} + MTTR_{(T1)}} \quad (4.30)$$

$$U_{B2(A)+T2} = \lambda_{B2(A)+T2} \times \frac{MTTR_{(B2)} \times MTTR_{(T2)}}{MTTR_{(B2)} + MTTR_{(T2)}} \quad (4.31)$$

$$U_{B2(A)+T1} = \lambda_{B2(A)+T1} \times \frac{MTTR_{(B2)} \times MTTR_{(T1)}}{MTTR_{(B2)} + MTTR_{(T1)}} \quad (4.32)$$

The calculation results of the failure rates and unavailability contributed by all of above overlapping failure minimal cut sets are described in Table 4.2 and Table 4.3 respectively.

Table 4.2: Failure rates due to secondary overlapping failure mode

Failure rates (f/yr) due to overlapping failure mode	
B1+B2	7.13576E-05
B3+B4	7.13576E-05
B3+T2	1.77204E-04
B4+T1	1.77204E-04
T1+T2	4.40090E-04
B1(A)+B3	4.76425E-05
B1(A)+B4	4.76425E-05
B3(A)+B2	4.76425E-05
B2(A)+B4	4.76425E-05
B1(A)+T2	1.18310E-04

B1(A)+T1	1.18310E-04
B2(A)+T2	1.18310E-04
B2(A)+T1	1.18310E-04
Total (λ_o)	1.60102E-03

Table 4.3: Unavailability due to secondary overlapping failure mode

Unavailability (hr/yr) due to overlapping failure mode	
B1+B2	1.42715E-04
B3+B4	1.42715E-04
B3+T2	5.59593E-04
B4+T1	5.59593E-04
T1+T2	3.30067E-03
B1(A)+B3	9.52851E-05
B1(A)+B4	9.52851E-05
B3(A)+B2	9.52851E-05
B2(A)+B4	9.52851E-05
B1(A)+T2	3.73611E-04
B1(A)+T1	3.73611E-04
B2(A)+T2	3.73611E-04
B2(A)+T1	3.73611E-04
Total (U_o)	6.58087E-03

When all of the contributions of the minimal cut sets based on the failure modes have been calculated, the overall reliability indices of the distribution substation are evaluated by summation of all of these contributions. The substation reliability indices can be calculated as follows by using equation (4.33), (4.34) and (4.35).

$$\begin{aligned}\lambda &= \lambda_t + \lambda_a + \lambda_s + \lambda_o \\ &= 2 \times 10^{-3} + 1.6 \times 10^{-2} + 0.03 + 1.60102 \times 10^{-3} = 4.9601 \times 10^{-2} \text{ (} f/\text{yr)}\end{aligned}\quad (4.33)$$

$$\begin{aligned}U &= U_t + U_a + U_s + U_o \\ &= 4 \times 10^{-3} + 1.6 \times 10^{-2} + 0.03 + 6.58087 \times 10^{-3} \\ &= 5.65809 \times 10^{-2} \text{ (} hr/\text{yr)} = 3.39485 \text{ (} \text{min}/\text{yr)}\end{aligned}\quad (4.34)$$

$$r = \frac{U}{\lambda} = \frac{3.39485}{4.9601 \times 10^{-2}} = 68.44 \text{ min}\quad (4.35)$$

The percentage changes of unavailability calculated above and that from reference [2] is 3.83% which is acceptable. The detailed calculations of the reliability indices are done by Microsoft Excel software and is attached with this thesis. Similarly, the reliability indices of the other four different substation configurations can also be calculated by using the same method applied above. The calculation results of the other four different configurations are described in Appendix B. The calculation results of reliability indices of five substation configurations are described in Table 4.4.

Table 4.4: Calculation Results of Reliability Indices for Five Substation Configurations (Ignoring Submission Transmission)

Configuration	λ (f/yr)	r (min)	U (min/yr)
a	0.049601025	68.44319165	3.394852436
b	4.52071E-02	6.90185E+01	3.12012E+00
c	2.86160E-03	1.93120E+02	5.52630E-01
d	2.91406E-03	1.84140E+02	5.36594E-01
e	1.17415E-02	1.10926E+02	1.30244E+00

According to the results from Table 4.1, the configuration 'c' and configuration 'd' have best reliability indices than other three substation configurations. The single bus configuration has the worst reliability indices.

4.2 Composite Distribution System Reliability

After finding the reliability indices of the distribution substation, it is necessary to analyze the impact of substation reliability on composite distribution system reliability. The five types of distribution system are modified from RBTS Bus 4 system. These distribution systems are link arrangement, basic radial type, open loop, closed loop and primary network system [2] as shown in Fig. 4.2, Fig. 4.3, Fig. 4.4, Fig. 4.5 and Fig. 4.6 respectively.

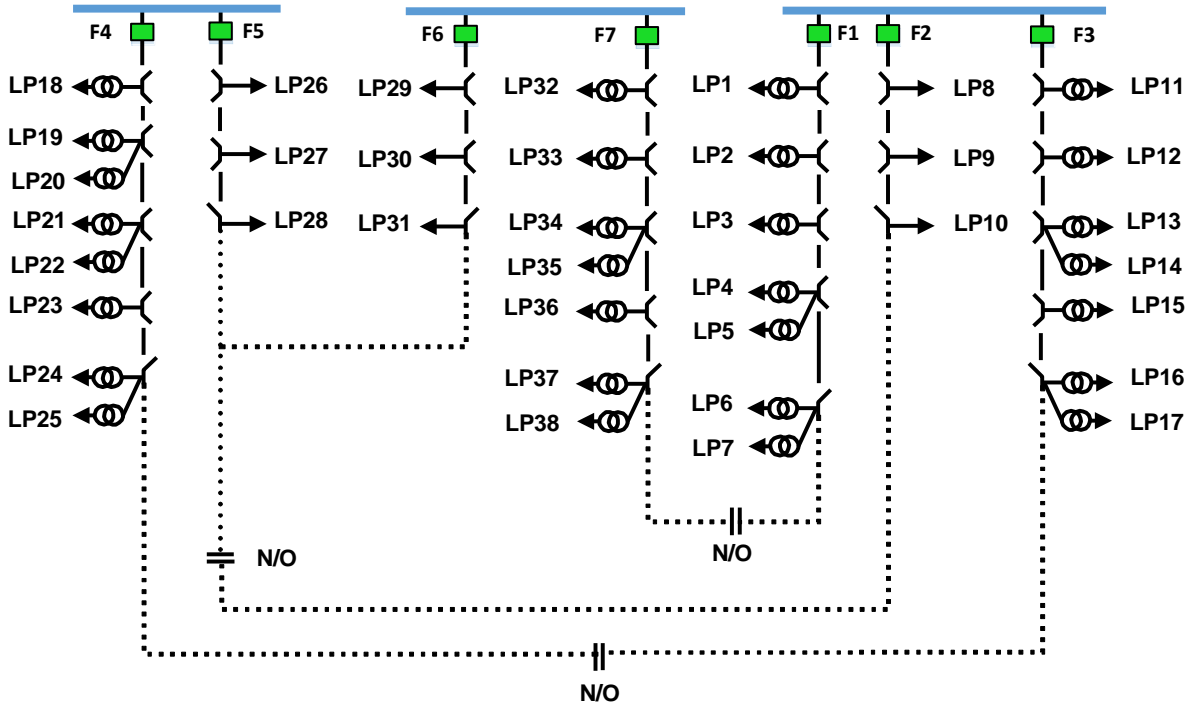

Fig. 4.2 Single line diagram of link arrangement system [2]

Fig. 4.2 shows the single line diagram of link arrangement system which is taken from RBTS Bus 4 [3]. The link arrangement system is composed of seven primary feeders which are connected to the three low voltage buses of three distribution substations [3]. Three normally open (N/O) tie disconnector switches are connected to the feeders to provide the alternative supply from different substation. When the fault occurs on one the substation, the electricity can be supplied by other substations after the fault has been isolated [2].

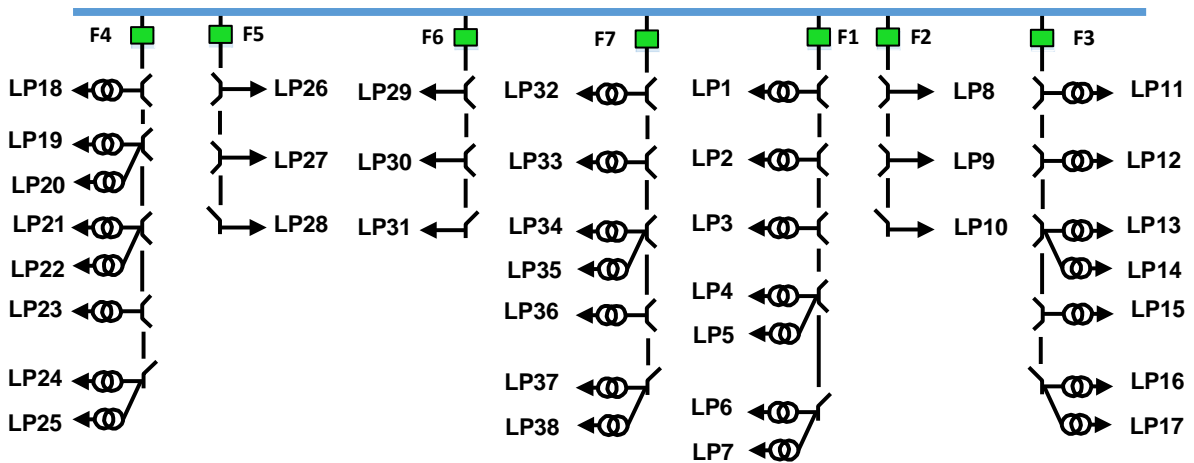

Fig. 4.3 Single line diagram of basic radial system [2]

Fig. 4.3 shows the single line diagram of the basic radial system in which all seven primary feeders are supplied by only one low voltage bus of distribution substation. When a fault occurs at the bus, all the customers at the load points will suffer power outage. When a fault occurs on one of the main sections of primary feeders, the customers located at the downstream of the faulted sections will have power outage [2].

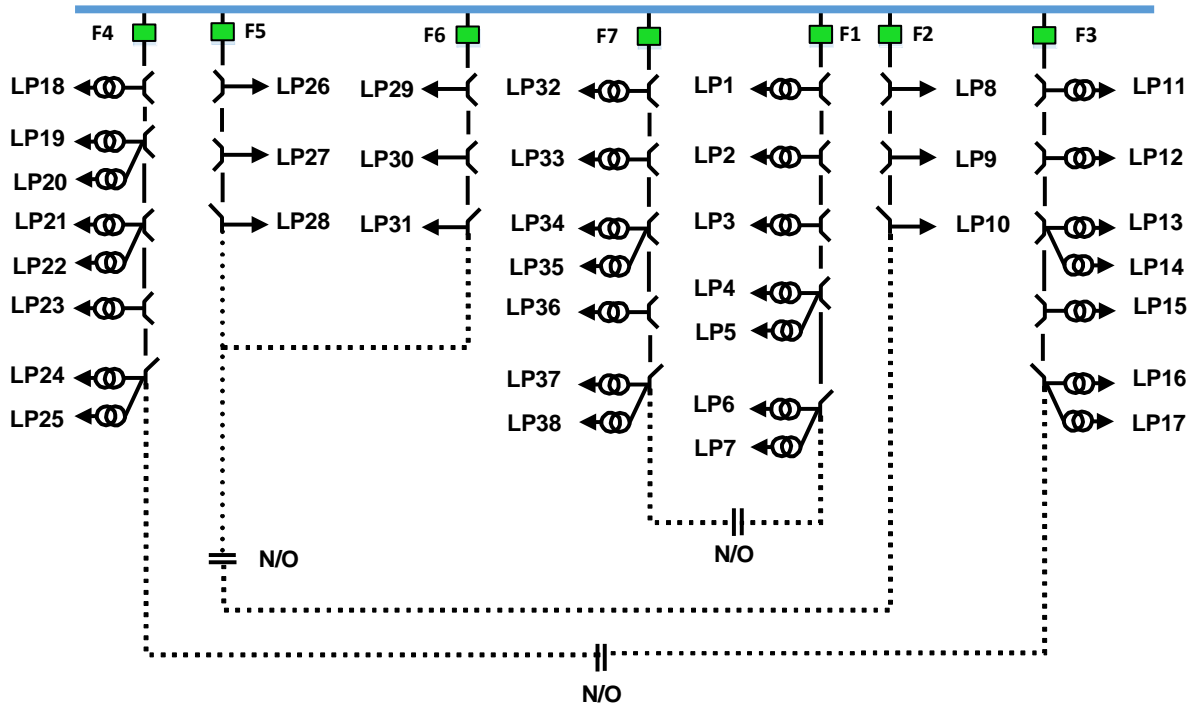

Fig. 4.4 Single line diagram of open loop system [2]

Fig. 4.4 shows the single line diagram of open loop system at which the primary feeders are also supplied by the single bus like basic radial system. But the primary feeders also connected with N/O and tie lines as shown in Fig 4.4. After the faulted section has been isolated, the N/O between the faulted feeder and adjacent feeders can be closed to supply the upfaulted sections [2].

Fig. 4.5 shows the single line diagram of closed loop system in which normally-closed (N/C) circuit breakers are used instead of N/O disconnectors. On the occurrence of a fault, the main feeder section and corresponding N/C circuit breaker will be opened to isolate the fault without affecting the customers at the upfaulted loop side [2].

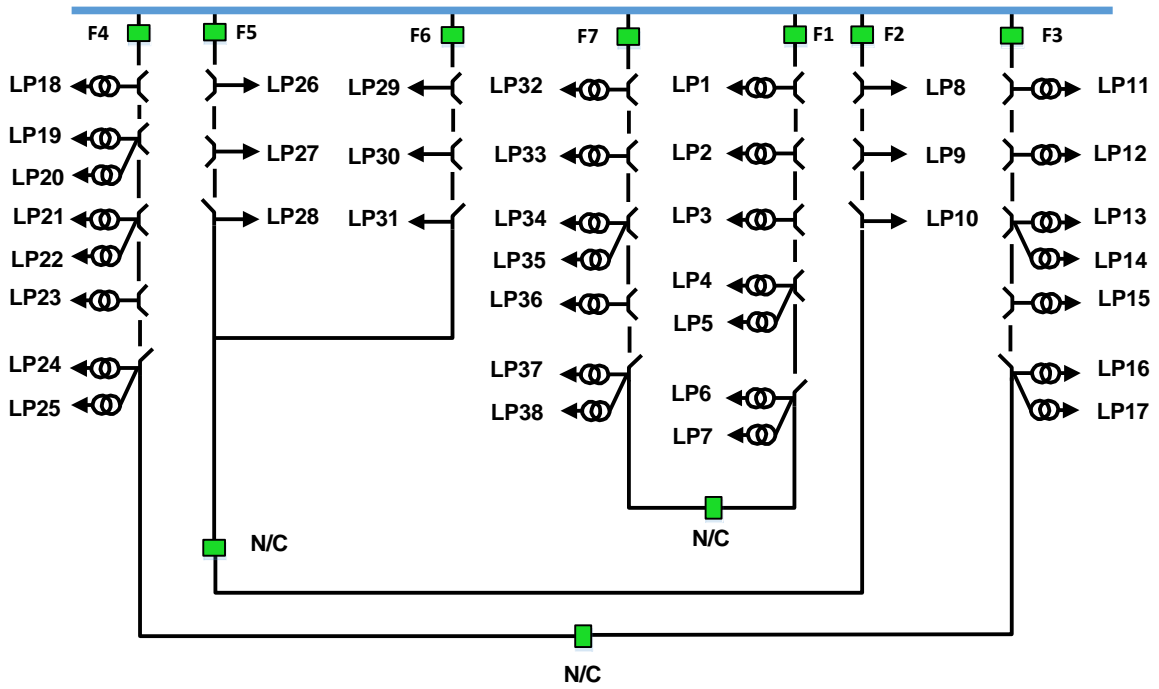

Fig. 4.5 Single line diagram of closed loop system [2]

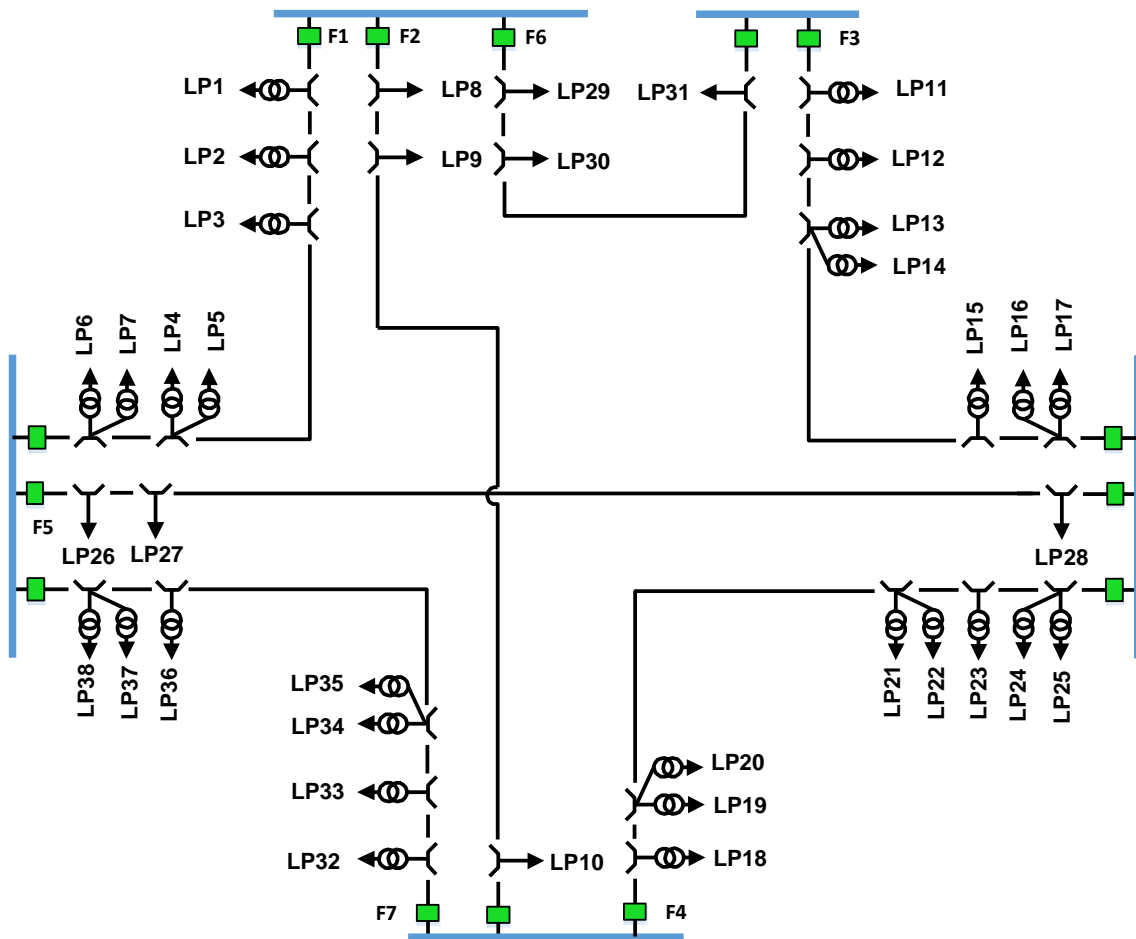

Fig. 4.6 Single line diagram of primary network system [2]

Fig. 4.6 shows the single line diagram of primary network system in which primary feeders are interconnected as a mesh and supplied by five different distribution substations. A substation failure does not have impact on any customer of the primary feeders [2].

4.2.1 Effect of Interaction between Distribution Substation and Primary Distribution System

The interaction between distribution substation and primary distribution system can be investigated by means of primary protection and back-up protection [2]. When a fault occur on a feeder circuit breaker and primary protection system is activated, all the feeder circuit breakers installed at the same bus are opened. Thus, the primary protection activation will cause loss of continuity supply and all the load point connected at the same low voltage bus suffer from power outage [2]. But the load points at the primary network can suffer power outage when the breakers connected at the two ends of a primary feeder trip simultaneously [2]. The effect of primary protection on the reliability indices of the load points can be calculated by using equation (4.36), (4.37) and (4.38) [2].

For primary network type:

$$\begin{aligned}\lambda_{CB,i}^a &= 2 \times \lambda_{cb}^a \\ U_{CB,i}^a &= 2 \times \lambda_{cb}^a \times t_s\end{aligned}\tag{4.36}$$

For the basic radial type:

$$\begin{aligned}\lambda_{CB,i}^a &= N_{cb} \times \lambda_{cb}^a \\ U_{CB,i}^a &= \lambda_{cb}^a \times [r_{cb} + (N_{cb} - 1) \times t_s]\end{aligned}\tag{4.37}$$

For other three types:

$$\begin{aligned}\lambda_{CB,i}^a &= N_{cb} \times \lambda_{cb}^a \\ U_{CB,i}^a &= N_{cb} \times \lambda_{cb}^a \times t_s\end{aligned}\tag{4.37}$$

When the primary protection is not activated to isolate the fault, the backup protection of the feeder breakers connected at the same low voltage bus will come into operation to clear the fault. When backup protection operate successfully, power interruption will occur to the load points supplied by the de-energizing bus for every type except the

primary network [2]. The effect of back up protection on the reliability indices (λ_{stuck} and U_{stuck}) of the load points can be calculated by using equation (4.39) and (4.40) [2].

for primary network

$$\begin{aligned}\lambda_{stuck,i} &= 0 \\ U_{stuck,i} &= 0\end{aligned}\tag{4.38}$$

for the other four types:

$$\begin{aligned}\lambda_{stuck,i} &= P_C \times \sum_{m=1, m \neq f_i}^{Nm} \lambda_m \\ U_{stuck,i} &= P_C \times \sum_{m=1, m \neq f_i}^{Nm} \lambda_m \times t_s\end{aligned}\tag{4.39}$$

Where as $m \neq f_i$ refers to the exclusion of main feeder that serves the load point.

denotes that the main feeder that serves load point is excluded. The reliability indices of load point i contributed to by f_i are considered in the reliability model of primary distribution system.

4.2.2 Reliability Model for Primary Distribution System

After determining the effect of interaction between the distribution substation and primary distribution system, the reliability model of the five types of primary distribution systems are developed adapted from [2]. The reliability indices of the primary distribution system ($\lambda_{F,i}, U_{F,i}$) can be calculated by using the equation (4.40), (4.41) and (4.42) which are also adapted from [2].

For primary network and closed-loop;

$$\begin{aligned}\lambda_{F,i} &= \sum_{m=1}^{F_{mi}} \lambda_m + \lambda_{ti} + \lambda_{li} \\ U_{F,i} &= \left(\sum_{m=1}^{F_{mi}} \lambda_m \times t_s \right) + \lambda_{ti} \times r_{ti} + \lambda_{li} \times r_{li}\end{aligned}\tag{4.40}$$

For link arrangement and open loop;

$$\begin{aligned}\lambda_{F,i} &= \lambda_{cb}^p + \left(\sum_{m=1}^{F_{mi}} \lambda_m \right) + \lambda_{ti} + \lambda_{li} \\ U_{F,i} &= \lambda_{cb}^p \times t_s + \left(\sum_{m=1}^{F_{mi}} \lambda_m \times t_s \right) + \lambda_{ti} \times r_{ti} + \lambda_{li} \times r_{li}\end{aligned}\tag{4.41}$$

For basic radial;

$$\begin{aligned}\lambda_{F,i} &= \lambda_{cb}^p + \left(\sum_{m=1}^{F_{m_i}} \lambda_m \right) + \lambda_{ii} + \lambda_{li} \\ U_{F,i} &= \lambda_{cb}^p \times r_{cb} + \sum_{m=1}^{m_i} \lambda_m \times r_m + \left(\sum_{m=m_i+1}^{F_{m_i}} \lambda_m \times t_s \right) + \lambda_{ii} \times r_{ii} + \lambda_{li} \times r_{li}\end{aligned}\tag{4.42}$$

The inequation $m \leq m_i$ refers to the m^{th} main section located upstream of load point i and $m_i + 1 \leq m \leq F_{m_i}$ is downstream of load point, i [2].

4.2.3 Composite Load Point Reliability Evaluation Model

Composite load point reliability indices such as $\lambda_{LP,i}$, $r_{LP,i}$, and $U_{LP,i}$ can then be evaluated by summing up all the reliability models obtained from the above section and can be calculated by using equations (4.43), (4.44) and (4.45).

$$\lambda_{LP,i} = \lambda_{S,i} + \lambda_{CB,i}^a + \lambda_{stuck,i} + \lambda_{F,i}\tag{4.43}$$

$$U_{LP,i} = U_{S,i} + U_{CB,i}^a + U_{stuck,i} + U_{F,i}\tag{4.44}$$

$$r_{LP,i} = \frac{U_{LP,i}}{\lambda_{LP,i}}\tag{4.45}$$

In [2], only these equations discussed above are described. No detailed calculation has not been described. Thus, the following sections will explain the detailed calculations of composite load point reliability indices for the link arrangement primary distribution system.

4.2.4 Calculation of Load Point Reliability Indices for Distribution System

For distribution substation reliability indices ($\lambda_{S,i}$ and $U_{S,i}$), the calculation has been made in section 4.1. There are some percentage changes in the calculation results. To illustrate the calculation of the composite distribution reliability indices ($\lambda_{LP,i}$, $r_{LP,i}$, and $U_{LP,i}$) and compare the results with that from [2], substation reliability indices are also taken from

[2] to minimize the error percentage in the calculation. The substation reliability indices from [2] are shown in Table 4.5 and 4.6.

Table 4.5: Reliability for five substation configurations (including subtransmission failure) [2]

Including subtransmission line failure			
Configuration	λ (/yr)	r (minutes)	U (minutes/yr)
a	0.0549	80.5	4.42
b	0.0459	76.35	3.5
c	0.00356	175.76	0.63
d	0.00572	125.14	0.72
e	0.0235	92.2	2.17

Table 4.6: Reliability for five substation configurations (ignoring subtransmission failure) [2]

Ignoring subtransmission line failure			
Configuration	λ (/yr)	r (minutes)	U (minutes/yr)
a	0.0489	72.15	3.53
b	0.0453	71.95	3.26
c	0.00301	184.56	0.56
d	0.00567	124.216	0.7
e	0.0174	81.88	1.42

In [2], it has not described which substation reliability indices (Table 4.2 or Table 4.3) are used to calculate the composite reliability indices for load points (LP8, LP9 and LP10) of five primary distribution systems. In this thesis work, substation reliability from both tables (Table 4.5 and Table 4.6) are used to investigate the reliability evaluation of composite distribution system and the calculation results are described in Appendix C. But as an example, the distribution system reliability indices of the link arrangement type is calculated in this section to give a clear illustration of composite system reliability indices calculation and the substation reliability indices from Table 4.6 are used. Thus, substation reliability indices ($\lambda_{s,i}, U_{s,i}$) for configuration 'a' is as follows.

$$\begin{aligned}\lambda_{s,i} &= 0.0489 \left(\frac{f}{yr} \right) \\ U_{s,i} &= 3.53 \left(\frac{\text{min}}{yr} \right)\end{aligned}\tag{4.46}$$

There are three feeder circuit breakers ($N_{cb} = 3$) connected at the same low voltage bus for the link arrangement type in Fig. 4.2 and the time required to perform the required isolation, switching, and load transfer actions is 1 hour ($t_s = 1hr$) from Table 4.1 originally adapted from [31]. Reliability indices contributed by the primary protection ($\lambda_{CB,i}^a, U_{CB,i}^a$) for the link arrangement type can then be calculated by using equation (4.37).

$$\begin{aligned}\lambda_{CB,i}^a &= N_{cb} \times \lambda_{cb}^a = 3 \times 0.004 = 0.012 \left(\frac{f}{yr} \right) \\ U_{CB,i}^a &= N_{cb} \times \lambda_{cb}^a \times t_s = 3 \times 0.004 \times 1 \times 60 = 0.72 \left(\frac{\text{min}}{yr} \right)\end{aligned}\tag{4.47}$$

The reliability indices contributed by backup protection ($\lambda_{stuck,i}, U_{stuck,i}$) for the link arrangement type can also be calculated by using equation (4.39). The failure rates of main feeder section are taken from Table A.2. In this case, the failure rates of main feeder sections which serves load point i is excluded. As load point LP8, LP9 and LP10 are connected under the same feeder F2, the main feeder sections from feeder F2 is excluded in the calculation. Main sections of primary feeders, F1 and F3 are feeder section number (1,3,5,7,10) and (19,21,23,26,28) which can be seen from Fig. 2.8 and the failure rates of each main section can be calculated by multiplying the feeder length from Table A.2 [3] and the line failure rate from Table 4.1 [3]. For load point LP8, LP9 and LP10, the reliability indices ($\lambda_{stuck,i}, U_{stuck,i}$) are the same and can be calculated by using equation (4.39) as follows.

$$\begin{aligned}\lambda_{stuck,i} &= P_C \times \left[\sum_{m=1, m \neq f_i}^{Nm} \lambda_m \right] \\ &= 0.05 \times [(0.6 \times 3 + 0.75 \times 3 + 0.8 \times 4) \times 0.065] = 2.356 \times 10^{-2} \left(\frac{f}{yr} \right) \\ U_{stuck,i} &= P_C \times \sum_{m=1, m \neq f_i}^{Nm} \lambda_m \times t_s \\ &= 2.356 \times 10^{-2} \times 1 \times 60 = 1.414 \left(\frac{\text{min}}{yr} \right)\end{aligned}\tag{4.48}$$

The reliability indices of the primary distribution system ($\lambda_{F,i}, U_{F,i}$) for the link arrangement type can be calculated by using the equation (4.40). In this case, the passive failure rate of the circuit breaker is needed to be calculated first by using equation (4.48) [19].

$$\lambda_{cb}^p = \lambda_{cb}^t - \lambda_{cb}^a = 0.006 - 0.004 = 0.002 \left(\frac{f}{yr} \right) \quad (4.49)$$

The main feeder sections from feeder F2 is excluded in the calculation of the effect of interaction between distribution substation and primary distribution system as described in equation (4.48). In this case, the main feeder sections and lateral sections of feeder F2 are considered. Care must be taken for the consideration of main sections that serves the load point, i . As a fault occurred on any of the main sections can cause power interruption to all load points, number of main sections of a primary feeder which services load point i is the same for LP8, LP9 and LP10. But the lateral section for load point LP8, LP9 and LP10 are not the same. As load point are connected to the main section via 100% reliable fuse and disconnectors as shown in Fig. 3.8, a fault occurred on any lateral section of the load point will cause the power interruption to that faulted load point only. For load point LP8, main sections considered are feeder section number (13,15,17) and lateral section is feeder section number (14) as shown in Fig. 3.8. For load point LP9, main sections considered are feeder section number (13,15,17) and lateral section is feeder section number (16). For load point LP10, main sections considered are feeder section number (13,15,17) and lateral section is feeder section number (18). As these load points are directly supplied via primary feeder without connecting to step down transformer, failure rate of distribution transformer that serves the load point, i (λ_{ii}) is zero in this case. The reliability indices of the primary distribution system ($\lambda_{F,i}, U_{F,i}$) for load point LP8, LP9 and LP10 can be calculated as follows.

For LP8,

$$\begin{aligned}
 \lambda_{F,i} &= \lambda_{cb}^p + \left(\sum_{m=1}^{F_{mi}} \lambda_m \right) + \lambda_{ii} + \lambda_{li} \\
 &= 0.002 + \left[(1 \times 0.6 + 2 \times 0.8) \times 0.065 \right] + 0 + (0.6 \times 0.065) = 0.184 \left(\frac{f}{yr} \right) \\
 U_{F,i} &= \lambda_{cb}^p \times t_s + \left(\sum_{m=1}^{F_{mi}} \lambda_m \times t_s \right) + \lambda_{ii} \times r_{ii} + \lambda_{li} \times r_{li} \\
 &= 0.002 \times 1 \times 60 + \left[(1 \times 0.6 + 2 \times 0.8) \times 0.065 \times 1 \times 60 \right] + 0 + (0.6 \times 0.065) \times 5 \\
 &= 20.4 \left(\frac{\text{min}}{yr} \right)
 \end{aligned} \tag{4.50}$$

For load point LP9,

$$\begin{aligned}
 \lambda_{F,i} &= \lambda_{cb}^p + \left(\sum_{m=1}^{F_{mi}} \lambda_m \right) + \lambda_{ii} + \lambda_{li} \\
 &= 0.002 + \left[(1 \times 0.6 + 2 \times 0.8) \times 0.065 \right] + 0 + (0.75 \times 0.065) = 0.19375 \left(\frac{f}{yr} \right) \\
 U_{F,i} &= \lambda_{cb}^p \times t_s + \left(\sum_{m=1}^{F_{mi}} \lambda_m \times t_s \right) + \lambda_{ii} \times r_{ii} + \lambda_{li} \times r_{li} \\
 &= 0.002 \times 1 \times 60 + \left[(1 \times 0.6 + 2 \times 0.8) \times 0.065 \times 1 \times 60 \right] + 0 + (0.75 \times 0.065) \times 5 \\
 &= 23.325 \left(\frac{\text{min}}{yr} \right)
 \end{aligned} \tag{4.51}$$

For load point LP10,

$$\begin{aligned}
 \lambda_{F,i} &= \lambda_{cb}^p + \left(\sum_{m=1}^{F_{mi}} \lambda_m \right) + \lambda_{ii} + \lambda_{li} \\
 &= 0.002 + \left[(1 \times 0.6 + 2 \times 0.8) \times 0.065 \right] + 0 + (0.8 \times 0.065) = 0.197 \left(\frac{f}{yr} \right) \\
 U_{F,i} &= \lambda_{cb}^p \times t_s + \left(\sum_{m=1}^{F_{mi}} \lambda_m \times t_s \right) + \lambda_{ii} \times r_{ii} + \lambda_{li} \times r_{li} \\
 &= 0.002 \times 1 \times 60 + \left[(1 \times 0.6 + 2 \times 0.8) \times 0.065 \times 1 \times 60 \right] + 0 + (0.8 \times 0.065) \times 5 \\
 &= 24.3 \left(\frac{\text{min}}{yr} \right)
 \end{aligned} \tag{4.52}$$

Finally, the reliability indices of composite distribution system for load point LP8, LP9 and LP10 can be calculated by using equation (4.43), (4.44) and the results from equation (4.46) to (4.52) as follows.

For load point LP8,

$$\begin{aligned}\lambda_{LP,i} &= \lambda_{S,i} + \lambda_{CB,i}^a + \lambda_{stuck,i} + \lambda_{F,i} \\ &= 0.0489 + 0.012 + 2.356 \times 10^{-2} + 0.184 \\ &= 0.2685 \left(\frac{f}{yr} \right)\end{aligned}\quad (4.53)$$

$$\begin{aligned}U_{LP,i} &= U_{S,i} + U_{CB,i}^a + U_{stuck,i} + U_{F,i} \\ &= 3.53 + 0.72 + 1.414 + 20.4 \\ &= 26.06 \left(\frac{\text{min}}{yr} \right)\end{aligned}\quad (4.54)$$

For load point LP9,

$$\begin{aligned}\lambda_{LP,i} &= \lambda_{S,i} + \lambda_{CB,i}^a + \lambda_{stuck,i} + \lambda_{F,i} \\ &= 0.0489 + 0.012 + 2.356 \times 10^{-2} + 0.19375 \\ &= 0.2782 \left(\frac{f}{yr} \right)\end{aligned}\quad (4.55)$$

$$\begin{aligned}U_{LP,i} &= U_{S,i} + U_{CB,i}^a + U_{stuck,i} + U_{F,i} \\ &= 3.53 + 0.72 + 1.414 + 23.205 \\ &= 28.99 \left(\frac{\text{min}}{yr} \right)\end{aligned}\quad (4.56)$$

For load point LP10,

$$\begin{aligned}\lambda_{LP,i} &= \lambda_{S,i} + \lambda_{CB,i}^a + \lambda_{stuck,i} + \lambda_{F,i} \\ &= 0.0489 + 0.012 + 2.356 \times 10^{-2} + 0.197 \\ &= 0.2815 \left(\frac{f}{yr} \right)\end{aligned}\quad (4.57)$$

$$\begin{aligned}U_{LP,i} &= U_{S,i} + U_{CB,i}^a + U_{stuck,i} + U_{F,i} \\ &= 3.53 + 0.72 + 1.414 + 24.3 \\ &= 29.96 \left(\frac{\text{min}}{yr} \right)\end{aligned}\quad (4.58)$$

When the calculation results are compared with that from [2], the percentage changes are less than 5% which is acceptable. This illustration is only for the composite reliability indices of link arrangement type with respect to substation configuration 'a'. Similarly, the composite reliability indices of link arrangement type with respect to other four

substation configurations (configuration 'b', 'c', 'd' and 'e') from Fig. 4.1 can be calculated by changing the corresponding values of $(\lambda_{S,i}, U_{S,i})$.

The load point indices of basic radial system, open loop system, closed-loop system, primary network system can also be calculated by using corresponding equations from equation (4.35) to (4.44) and the substation reliability values from Table 4.5 and Table 4.6. The calculation works are done by using Microsoft Excel software and the calculation results are shown in Appendix C. The summary of the composite load point reliability indices $(\lambda_{LP,i}, U_{LP,i})$ and shown in Table 4.7 and Table 4.8 respectively. Their corresponding reliability indices are summarized as the bar chart in Fig.4.7 and 4.8 respectively to compare the reliability levels of distribution substations and composite distribution systems.

Table 4.7: Failure rates $(\lambda_{LP,i})$ of load points at feeder F2

		Basic radial system	Link arrangement system	Open loop system	Close loop system	Primary network system
A	LP8	0.3231375	0.2684625	0.3231375	0.3211375	0.19
	LP9	0.3328875	0.2782125	0.3328875	0.3308875	0.19975
	LP10	0.3361375	0.2814625	0.3361375	0.3341375	0.203
B	LP8	0.3195375	0.2648625	0.3195375	0.3175375	0.19
	LP9	0.3292875	0.2746125	0.3292875	0.3272875	0.19975
	LP10	0.3325375	0.2778625	0.3325375	0.3305375	0.203
C	LP8	0.2772475	0.2225725	0.2772475	0.2752475	0.19
	LP9	0.2869975	0.2323225	0.2869975	0.2849975	0.19975
	LP10	0.2902475	0.2355725	0.2902475	0.2882475	0.203
D	LP8	0.2799075	0.2252325	0.2799075	0.2779075	0.19
	LP9	0.2896575	0.2349825	0.2896575	0.2876575	0.19975
	LP10	0.2929075	0.2382325	0.2929075	0.2909075	0.203
E	LP8	0.2916375	0.2369625	0.2916375	0.2896375	0.19
	LP9	0.3013875	0.2467125	0.3013875	0.2993875	0.19975
	LP10	0.3046375	0.2499625	0.3046375	0.3026375	0.203

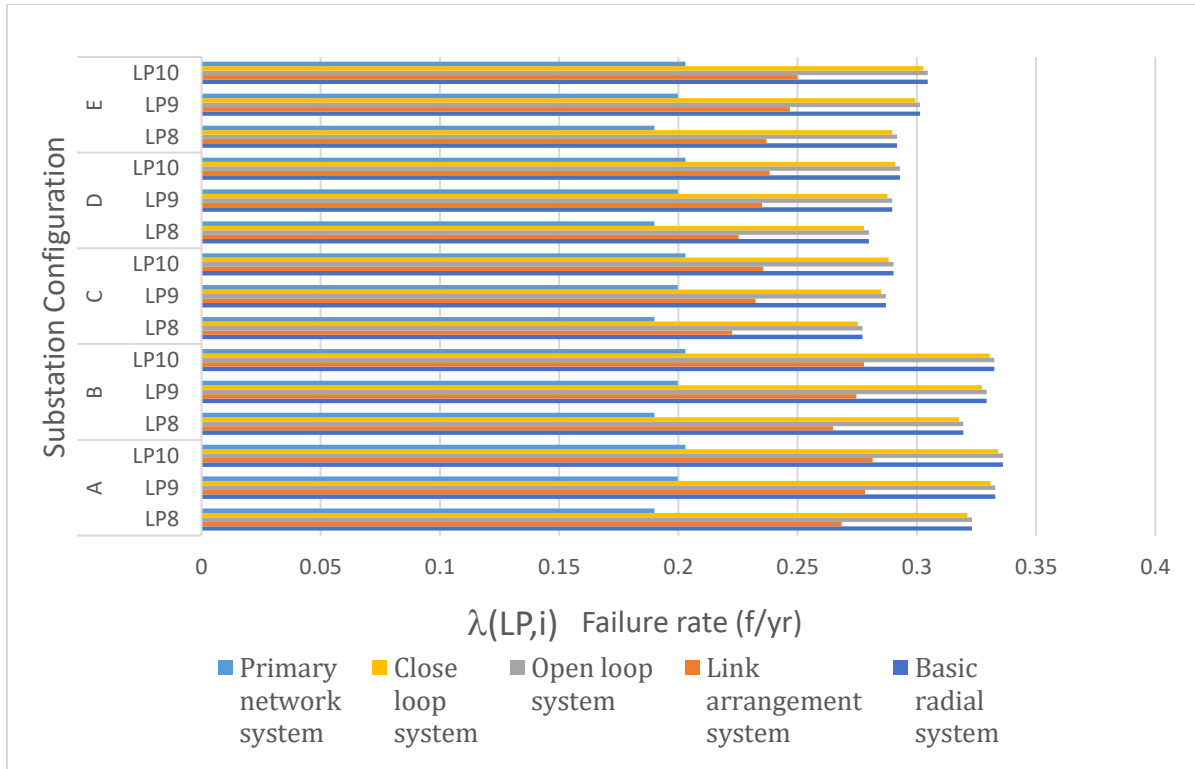

Fig. 4.7 Comparison of failure rates for five composite distribution systems

Table 4.8: Unavailability ($U_{LP,i}$) of load points at feeder F2

		Basic radial system	Link arrangement system	Open loop system	Close loop system	Primary network system
A	LP8	42.90425	26.06375	29.34425	29.22425	20.76
	LP9	58.30925	28.98875	32.26925	32.14925	23.685
	LP10	68.64425	29.96375	33.24425	33.12425	24.66
B	LP8	42.63425	25.79375	29.07425	28.95425	20.76
	LP9	58.03925	28.71875	31.99925	31.87925	23.685
	LP10	68.37425	29.69375	32.97425	32.85425	24.66
C	LP8	39.93425	23.09375	26.37425	26.25425	20.76
	LP9	55.33925	26.01875	29.29925	29.17925	23.685
	LP10	65.67425	26.99375	30.27425	30.15425	24.66
D	LP8	40.07425	23.23375	26.51425	26.39425	20.76
	LP9	55.47925	26.15875	29.43925	29.31925	23.685
	LP10	65.81425	27.13375	30.41425	30.29425	24.66
E	LP8	40.79425	23.95375	27.23425	27.11425	20.76
	LP9	56.19925	26.87875	30.15925	30.03925	23.685
	LP10	66.53425	27.85375	31.13425	31.01425	24.66

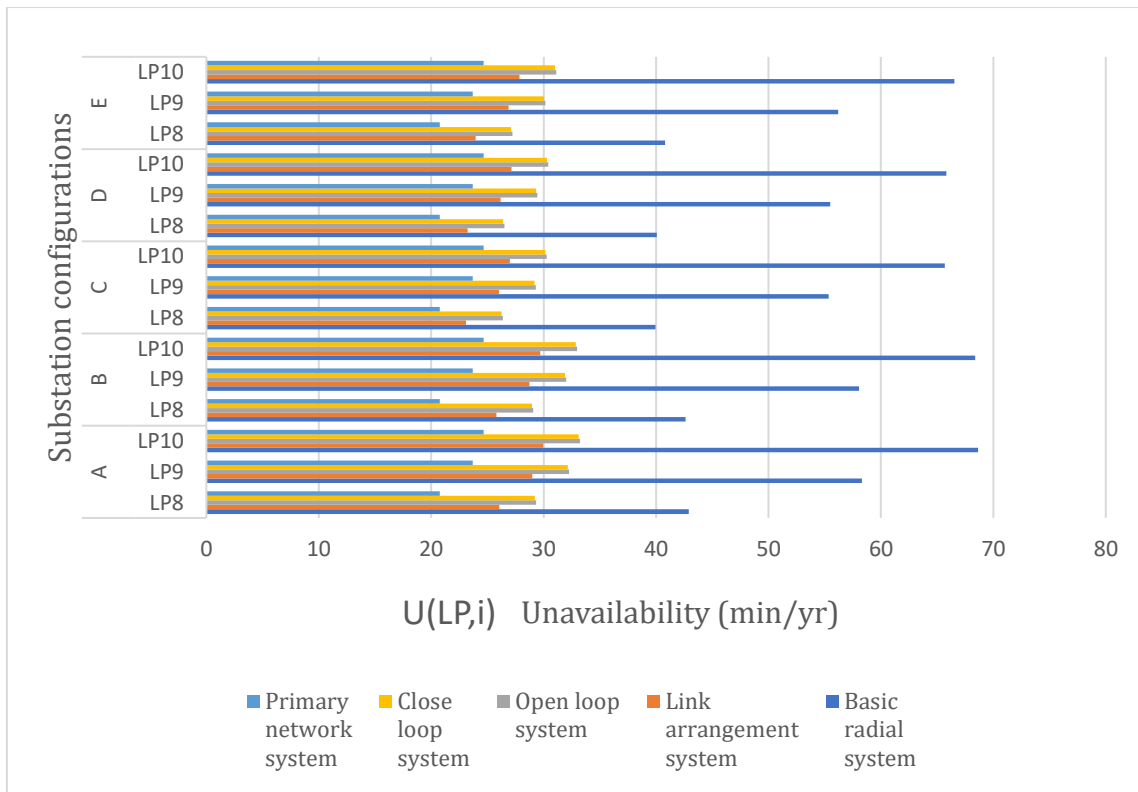

Fig. 4.8 Comparison of unavailability for five composite distribution systems

From the results of Table (4.5) and Table (4.6) as well as Fig. 4.7 and Fig. 4.8, the reliability levels of distribution substation configurations and the effect of substation reliability on composite distribution system reliability can be compared for reliability assessment as follows.

- Since the backup protection does not have impact on the primary network system, the feeders are connected as a mesh, the reliability indices of the primary network is the lowest (highest reliability) among five distribution system.
- The basic radial system has the highest reliability indices (lowest reliability level) than other because there is no alternative supply when a fault occurs on any feeder circuit breaker or on the main bus or at any location between the feeder circuit breaker and the main bus.
- The link arrangement has better reliability indices than close-loop and open-loop as the feeders are supplied from three different distribution substations which can provide alternative emergency supply to the customers at the load points of other distribution substations after the fault has isolated.

- The close-loop system is slightly better than open-loop system as the fault is automatically isolated by the normally-closed (N/C) circuit breaker and feeder circuit breaker at close-loop system where as the open loop system take longer time to isolate the fault.
- In Fig. 4.8, the unavailability of the load points is higher from load point LP8 to LP10 as there is no alternative supply to the un-faulted load points when the fault occurs. The load point nearest to the feeder circuit breaker has the lowest annual outage time as the service can be restored by 100% reliable disconnecting switches connected at the main feeder sections after the fault has been isolated from the faulted sections.
- Among the five substation configurations, one-and-a-half circuit breaker substation has better reliability impact on the composite distribution system than other four types of substation configuration. Double bus double breaker configuration is slightly less than the one-and-a-half circuit breaker configuration and next is ring bus configuration. The single bus configuration has the highest impact on the distribution system reliability indices as expected and sectionalized single bus configuration is slightly lesser impact than single bus configuration.

The basic reliability indices calculated above can represent the general overview of the reliability level of distribution system. But they *cannot give the complete representation of system behavior and response* [31] of the distribution system. Therefore, system reliability indices of the composite distribution system are needed to be evaluated.

4.2.5 Calculation of System Reliability Indices for Distribution System

In this section, some commonly used system reliability indices such as SAIFI, SAIDI, CAIDI, AENS are calculated to reflect the severity or significance of a system outage [3]. To calculate the system reliability indices, the customer data and load data are needed. These data are taken from reference [3] and described in Appendix A. To give a clear illustration, the calculation of system reliability indices for the link arrangement with respect to substation configuration 'a' is conducted by using the load point reliability

indices from Table 4.7 and Table 4.8. The customer data needed to consider for the calculation are taken from the RBTS Bus 4 [3] and described in Table 4.9.

Table 4.9: Customer Data of Feeder F2

Customer Data			
Load point	Average load level, MW	Number of customers	Customer type
LP8	1	1	small user
LP9	1.5	1	small user
LP10	1	1	small user
Total	3.5	3	

From Table 4.7, The failure rates of load points (LP8, LP9 and LP10) of link arrangement system with respect to substation configuration 'a' are (0.268625, 0.2782125 and 0.2814625) respectively. From Table 4.6, The unavailability of load points (LP8, LP9 and LP10) of link arrangement system with respect to substation configuration 'a' are (26.06375, 28.98875 and 29.96375) respectively.

The system reliability indices (SAIFI, SAIDI, CAIDI and AENS) can be calculated by using equation (3.6) to equation (3.9) in chapter 3 as follows.

$$\begin{aligned}
 SAIFI &= \frac{\sum \lambda_i N_i}{\sum N_i} \\
 &= \frac{0.268625 \times 1 + 0.2782125 \times 1 + 0.2814625 \times 1}{1 + 1 + 1} \\
 &= 0.276046 \left(\frac{\text{interruptions}}{\text{customer.yr}} \right)
 \end{aligned} \tag{4.59}$$

$$\begin{aligned}
 SAIDI &= \frac{\sum U_i N_i}{\sum N_i} \\
 &= \frac{26.06375 \times 1 + 28.98875 \times 1 + 29.96375 \times 1}{1 + 1 + 1} \\
 &= 28.3388 \left(\frac{\text{minutes}}{\text{customer.yr}} \right)
 \end{aligned} \tag{4.60}$$

$$\begin{aligned}
 CAIDI &= \frac{\sum U_i N_i}{\sum \lambda_i N_i} \\
 &= \frac{26.06375 \times 1 + 28.98875 \times 1 + 29.96375 \times 1}{0.268625 \times 1 + 0.2782125 \times 1 + 0.2814625 \times 1} \\
 &= 102.66 \left(\text{minutes/customer interruption} \right)
 \end{aligned} \tag{4.61}$$

$$\begin{aligned}
 AENS &= \frac{\sum L_{a(i)} U_i}{\sum N_i} \\
 &= \frac{(1 \times 26.06375 + 1.5 \times 28.98875 + 1 \times 29.96375) \times 10^3}{1 + 1 + 1} \\
 &= 33.1702 \left(\text{kWh/customer.yr} \right)
 \end{aligned} \tag{4.62}$$

Similarly, the system reliability indices for link arrangement system with respect to other four substation configurations and those for other four distribution system with respect to five substation configurations can be calculated by applying the same approach explained above. The calculation works are done by Microsoft Excel software and the results are shown in Appendix D. The summary of these system reliability indices (SAIFI, SAIDI, CAIDI and AENS) are shown in Fig. 4.9, Fig. 4.10, Fig. 4.11 and Fig. 4.12 respectively.

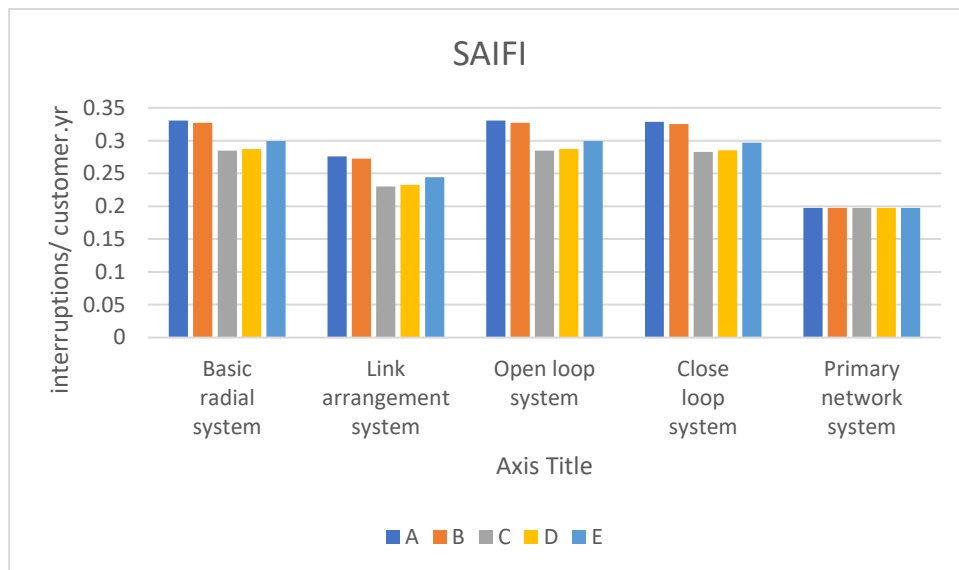

Fig. 4.9 Comparison of system reliability indice (SAIFI) for five distribution system

SAIFI has least impact on primary network system. The substation reliability indices do not have impact on system reliability indice (SAIFI) of primary network system. The link arrangement system has second lowest interruptions per customer. The other three types have nearly the same system reliability level (SAIFI value).

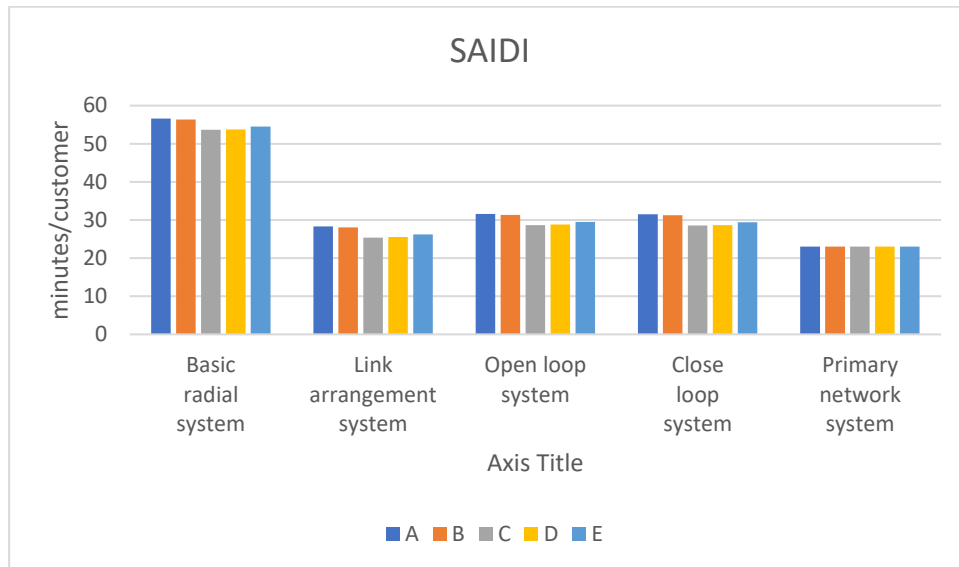

Fig. 4.10 Comparison of system reliability indice (SAIDI) for five distribution system. System reliability indice (SAIDI) of basic radial system is significantly higher than that of other four types as shown in Fig. 4.10. Substation reliability indices are affected very slightly to the system reliability indice (SAIDI) of four types excepts primary network system at which substation reliability has no impact on SAIDI.

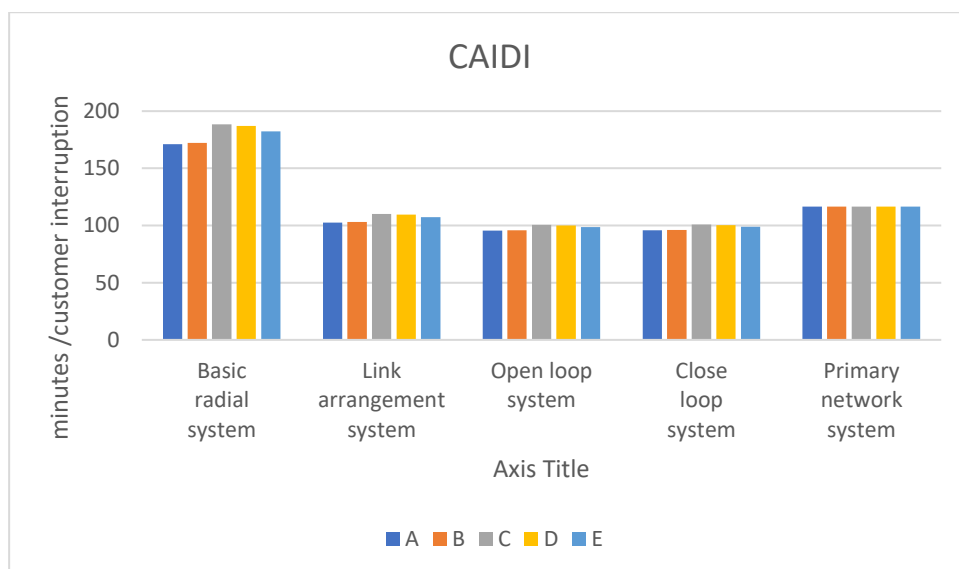

Fig. 4.11 Comparison of system reliability indice (CAIDI) for five distribution system

For system reliability indice (CAIDI), the basic radial system has the highest impact. But in this case, the primary network system has higher impact on CAIDI than other three type of distribution system. Substation reliability indices has only small impact on the system reliability indices (CAIDI) of five distribution system.

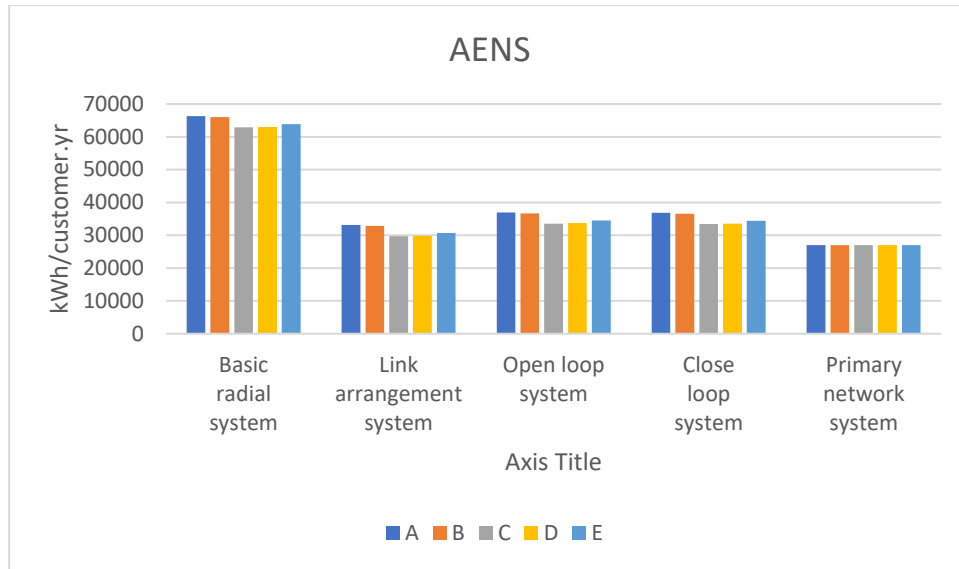

Fig. 4.12 Comparison of system reliability indice (AENS) for five distribution system

As the basic radial system has no alternative supply for the faulted feeder and all the load points suffer power outage when a fault occur either at any location between feeders and main bus or at any feeder circuit breaker or on the main bus. Thus, it has highest impact on AENS whereas the primary network system has the lowest impact on AENS. Link arrangement has better system reliability (AENS) than open loop system and close loop system.

These reliability indices (SAIFI, SAIDI, CAIDI and AENS) can be used to determine the system performance of the composite distribution system. The system reliability indices can also be used to make assessment for the severity of system failures on future reliability analysis [1].

From the results of system reliability indices shown in Fig. 4.9, Fig. 4.10, Fig. 4.11 and Fig. 4.12, it can be summarized as follows.

- Substation reliability indices have more impact on SAIFI than other three system reliability indices (SAIDI, CAIDI and AENS)[2].

- Substation configurations have no impact on the system reliability indices of primary network system [2].
- System reliability indices are more affected by primary distribution system rather than distribution substations[2].

Chapter 5

Case Study: Utilizing Fault Tree

Analysis for Substation Reliability

The previous chapter give a clear illustration of composite distribution system reliability evaluation by using minimal cut set method. In this section, the fault tree analysis (FTA) is used to evaluate the substation reliability indices as alternative approach and compare the results with that from minimal cut set method. The literature study of minimal cut set method and fault tree analysis have explained briefly in chapter 2. In this section, fault tree analysis is used to evaluate the substation reliability as an alternative approach for reliability assessment of distribution substation. For the simplicity, two substation configurations 'a' and 'b' in Fig. 4.1 (a) and Fig. 4.1 (b) are selected to investigate the reliability evaluation by using fault tree analysis (FTA) approach.

5.1 Investigation of Fault Tree Approach for Substation Configuration 'a'

The substation reliability indices of the single bus configuration in Fig. 4.1 (a) are calculated by the fault tree analysis (FTA). The reliability data of the single bus configuration in Table 4.1 is used as an input to the fault tree construction.

In this analysis, the disconnectors, fuses and subtransmission lines are assumed to be completely reliable and excluded in the calculation of fault tree analysis. The reliability indices of circuit breaker, transformer and busbar are considered in the reliability evaluation process.

The modeling technique of constructing the fault tree is based on the literature [20,21, 25, 42, 43]. The method includes tracing all components in the arrangement by power

flow direction [20]. Each component in the reliability consideration can be either in its operating state or unavailable state. The power flow direction of the single bus configuration is shown in Fig. 5.1 as follows.

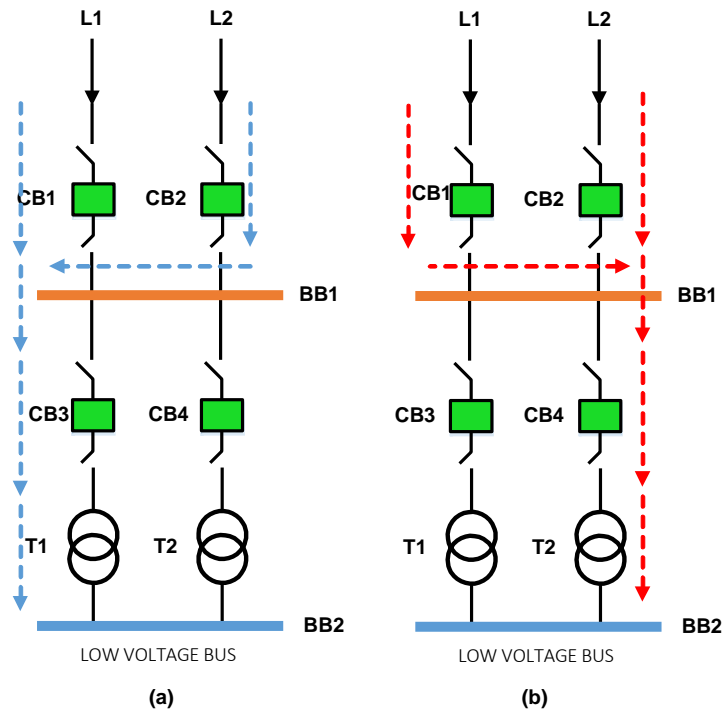

Fig. 5.1 Power flow direction of substation configuration 'a' (a: when either T2 or B4 are out of service, b: when either T1 or B3 are out of service)

Based on the Fig. 5.1 (a) and Fig. 5.1 (b), the fault tree is constructed to evaluate the annual outage time of single bus substation. As this configuration is symmetrical and the components used in the substation have the same reliability indices for same type of component, it is not necessary to construct fault tree for two power flow direction. Instead, only one power flow condition in Fig. 5.1 (a) is used to construct the fault tree. The results of the fault tree constructed for the Fig. 5.1 (a) can be used as the results of the fault tree for Fig. 5.1 (b).

'No power flow through Low voltage bus, BB2' is considered as the top event of the fault tree (TE). This condition can happen either when there is no power output from both transformers T1 and T2 or when the busbar BB2 has its own fault. When power flow output from transformer T1 is considered, the transformer T2 and circuit breaker B4 are assumed out of service and excluded in the calculation process of fault tree. Similarly, the power flow output from transformer T2 is considered, the transformer T1 and circuit breaker B3 is not included in the calculation process. For the power flow output from

transformer T1, substation failure can occur when either there is no power flow into the transformer T1 or total failure occurs on T1. 'No power flow into T1' is occurred by either 'no power into circuit breaker B3' or 'unavailability of T1 due to its own fault'. Similarly, 'no power flow into B3' can occur when either 'no power flow through busbar BB1' or 'unavailability of B1 due to its own fault such as passive failure or active failure'. 'No power flow through busbar BB1' can occur when either 'no power flow into BB1' or 'BB1 itself unavailability due to total failure'. 'No power flow into BB1' event can occur when 'no power flow through B1 and B2'. As the subtransmission line failure is not considered in this case, 'no power flow through B1' and 'no power flow through B2' is due to their own faults such as passive failure or active failure. In this modeling technique, the fault tree is constructed from the end point of the power flow to the start point of the power flow. The power flow outage occurs when any component in the power flow direction has failure. The failure effect is considered by the failure modes of consecutive components and the failure effect of the component at the upper level of the fault tree is not considered at the lower level of the fault tree.

Before constructing the fault tree for the reliability assessment, the unavailability of the basic events is needed to be calculated as a starting point of the fault tree calculation. The annual outage times of the components are calculated as follows [18].

Unavailability of circuit breaker due to active failure:

$$U_{AFCB} = \lambda_{A(CB)} \times t_s = 0.004 \times 1 = 0.004 (\text{hr}/\text{yr}) \quad (5.1)$$

Unavailability of circuit breaker due to passive failure:

$$U_{PFCB} = \lambda_{P(CB)} \times t_s = (\lambda_{T(CB)} - \lambda_{A(CB)}) \times t_s = (0.006 - 0.004) \times 1 = 0.002 (\text{hr}/\text{yr}) \quad (5.2)$$

As the active failure rate and the total failure rate are the same for transformer and busbar, there is no separate passive failure event for these two components.

Unavailability of transformer due to total failure:

$$U_{TF(T)} = \lambda_{T(T)} \times MTTR_T = 0.015 \times 15 = 0.225 (\text{hr}/\text{yr}) \quad (5.3)$$

Unavailability of busbar due to total failure:

$$U_{TF(BB)} = \lambda_{T(BB)} \times MTTR_{BB} = 0.001 \times 2 = 0.002 (\text{hr}/\text{yr}) \quad (5.4)$$

The fault tree diagram of substation configuration 'a' is shown in Fig. 5.2 below.

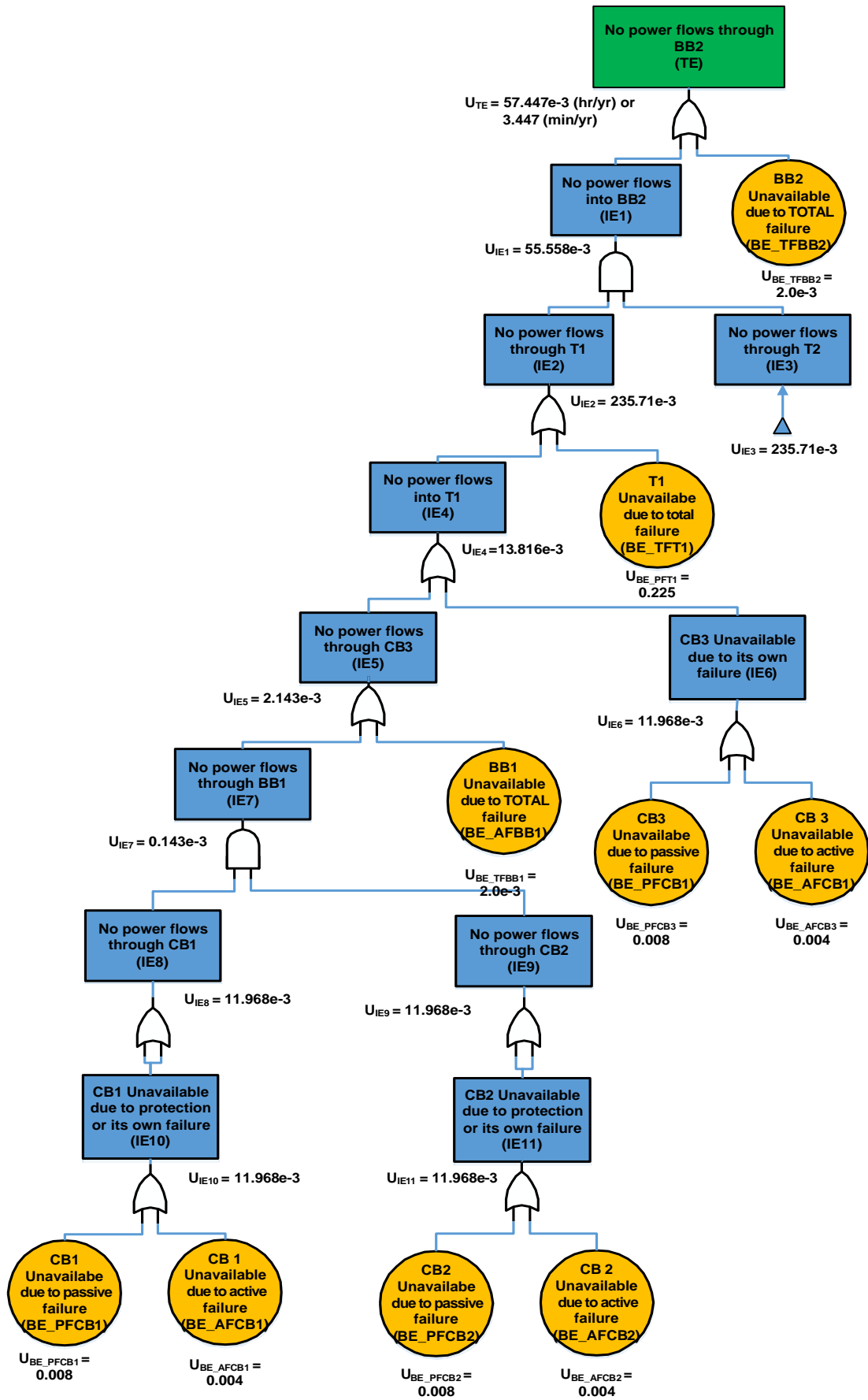

Fig. 5.2 Fault tree diagram of reliability analysis for substation configuration 'a'

As the fault tree diagram is needed to be read from the bottom to the top, the calculation process is conducted as follows. The basic events (BE) of the components are calculated in the above. The calculations of the intermediate events (IE) and the top event (TE) are conducted by using equation (5.5) and (5.16) described below.

$$\begin{aligned}
 U_{IE10} &= 1 - \left[(1 - U_{BE_PFCB1}) \times (1 - U_{BE_AFCB1}) \right] \\
 &= 1 - \left[(1 - 0.008) \times (1 - 0.004) \right] \\
 &= 11.968 \times 10^{-3} \text{ (hr/yr)}
 \end{aligned} \tag{5.5}$$

$$\begin{aligned}
 U_{IE11} &= 1 - \left[(1 - U_{BE_PFCB2}) \times (1 - U_{BE_AFCB2}) \right] \\
 &= 1 - \left[(1 - 0.008) \times (1 - 0.004) \right] \\
 &= 11.968 \times 10^{-3} \text{ (hr/yr)}
 \end{aligned} \tag{5.6}$$

$$U_{IE8} = U_{IE10} = 11.968 \times 10^{-3} \text{ (hr/yr)} \tag{5.7}$$

$$U_{IE9} = U_{IE11} = 11.968 \times 10^{-3} \text{ (hr/yr)} \tag{5.8}$$

$$\begin{aligned}
 U_{IE7} &= U_{IE8} \times U_{IE9} \\
 &= 11.968 \times 10^{-3} \times 11.968 \times 10^{-3} = 0.143 \times 10^{-3} \text{ (hr/yr)}
 \end{aligned} \tag{5.9}$$

$$\begin{aligned}
 U_{IE5} &= 1 - \left[(1 - U_{IE7}) \times (1 - U_{BE_TFBB1}) \right] \\
 &= 1 - \left[(1 - 0.143 \times 10^{-3}) \times (1 - 0.002) \right] \\
 &= 2.143 \times 10^{-3} \text{ (hr/yr)}
 \end{aligned} \tag{5.10}$$

$$\begin{aligned}
 U_{IE6} &= 1 - \left[(1 - U_{BE_PFCB3}) \times (1 - U_{BE_AFCB3}) \right] \\
 &= 1 - \left[(1 - 0.008) \times (1 - 0.004) \right] \\
 &= 11.968 \times 10^{-3} \text{ (hr/yr)}
 \end{aligned} \tag{5.11}$$

$$\begin{aligned}
 U_{IE4} &= 1 - \left[(1 - U_{IE6}) \times (1 - U_{IE5}) \right] \\
 &= 1 - \left[(1 - 11.968 \times 10^{-3}) \times (1 - 0.143 \times 10^{-3}) \right] \\
 &= 13.816 \times 10^{-3} \text{ (hr/yr)}
 \end{aligned} \tag{5.12}$$

$$\begin{aligned}
 U_{IE2} &= 1 - \left[(1 - U_{IE4}) \times (1 - U_{BE_TFT1}) \right] \\
 &= 1 - \left[(1 - 13.816 \times 10^{-3}) \times (1 - 0.225) \right] \\
 &= 235.71 \times 10^{-3} \text{ (hr/yr)}
 \end{aligned} \tag{5.13}$$

$$U_{IE3} = U_{IE2} = 235.71 \times 10^{-3} (\text{hr}/\text{yr}) \quad (5.14)$$

$$\begin{aligned} U_{IE1} &= U_{IE2} \times U_{IE3} \\ &= 235.71 \times 10^{-3} \times 235.7 \times 10^{-3} = 55.558 \times 10^{-3} (\text{hr}/\text{yr}) \end{aligned} \quad (5.15)$$

$$\begin{aligned} U_{TE} &= 1 - \left[(1 - U_{IE1}) \times (1 - U_{BE_TFBB2}) \right] \\ &= 1 - \left[(1 - 55.558 \times 10^{-3}) \times (1 - 0.002) \right] \\ &= 57.447 \times 10^{-3} (\text{hr}/\text{yr}) = 57.447 \times 10^{-3} \times 60 = 3.447 (\text{min}/\text{yr}) \end{aligned} \quad (5.16)$$

Compared with the results from literature [2], the percentage change is 2.07% which is acceptable for the illustration.

5.2 Investigation of Fault Tree Approach for Substation Configuration 'b'

The substation configuration 'b' is also evaluated by using fault tree analysis (FTA) approach. The power flow direction for the substation configuration 'b' is shown in Fig. 5.3 and fault tree diagram for substation configuration 'b' is shown in Fig. 5.4.

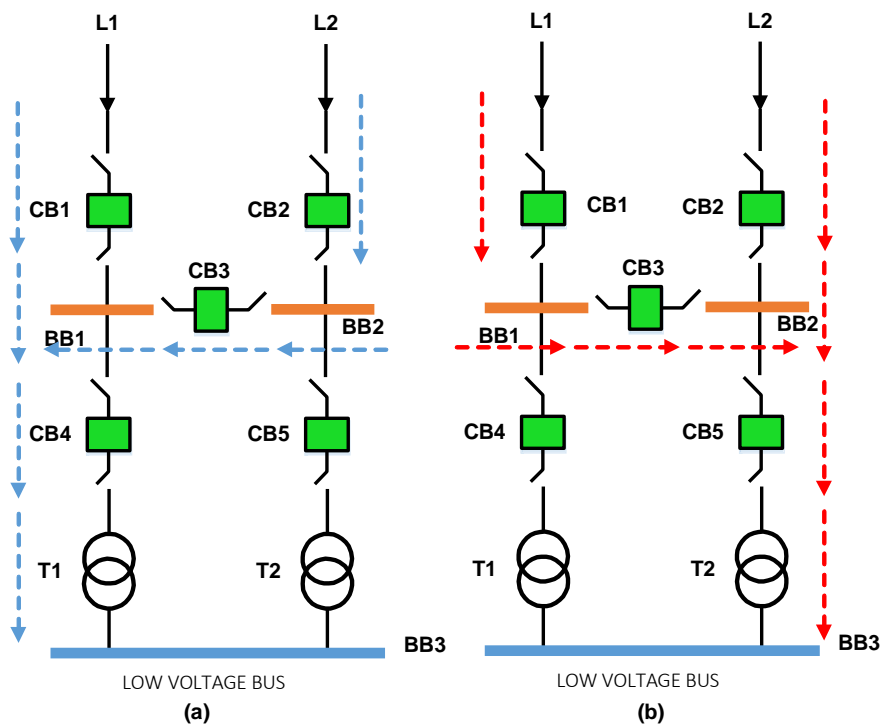

Fig. 5.3 Power flow direction of substation configuration 'b' (a: when either T2 or B4 are out of service, b: when either T1 or B3 are out of service)

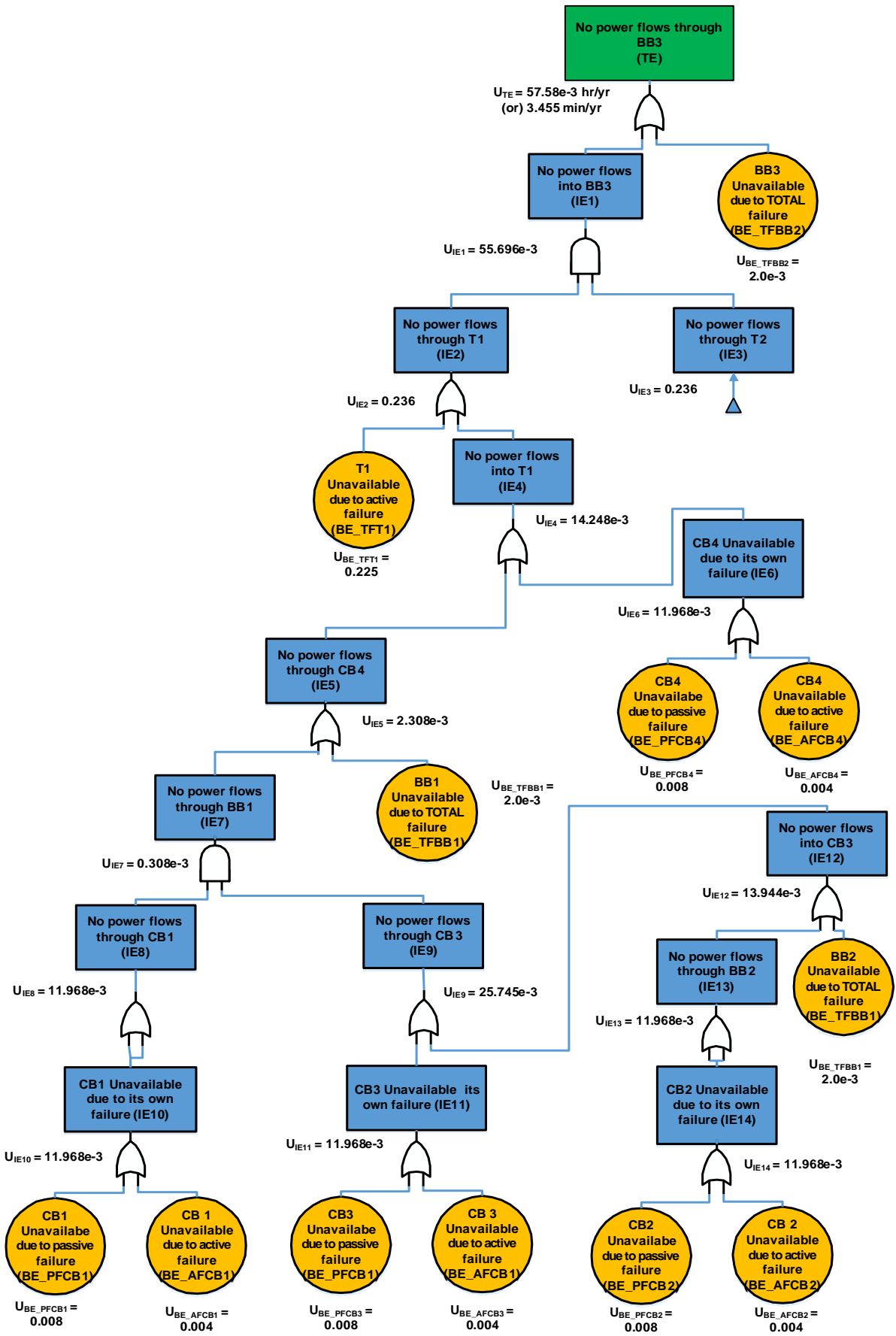

Fig. 5.4 Fault tree diagram of reliability analysis for substation configuration 'b'

In this case, the fault tree diagram is constructed by tracking the power flow direction of Fig. 5.3 (a) and apply the same procedure conducted in section 5.2. The unavailability indices of basic events (BE) are the same as those calculated in equation (5.1) to (5.4). The calculations of the intermediate events (IE) and top event (TE) are described below.

$$\begin{aligned}
 U_{IE10} &= 1 - \left[(1 - U_{BE_PFCB1}) \times (1 - U_{BE_AFCB1}) \right] \\
 &= 1 - \left[(1 - 0.008) \times (1 - 0.004) \right] \\
 &= 11.968 \times 10^{-3} \text{ (hr/yr)}
 \end{aligned} \tag{5.17}$$

$$\begin{aligned}
 U_{IE11} &= 1 - \left[(1 - U_{BE_PFCB2}) \times (1 - U_{BE_AFCB2}) \right] \\
 &= 1 - \left[(1 - 0.008) \times (1 - 0.004) \right] \\
 &= 11.968 \times 10^{-3} \text{ (hr/yr)}
 \end{aligned} \tag{5.18}$$

$$U_{IE8} = U_{IE10} = 11.968 \times 10^{-3} \text{ (hr/yr)} \tag{5.19}$$

$$\begin{aligned}
 U_{IE14} &= 1 - \left[(1 - U_{BE_PFCB2}) \times (1 - U_{BE_AFCB2}) \right] \\
 &= 1 - \left[(1 - 0.008) \times (1 - 0.004) \right] \\
 &= 11.968 \times 10^{-3} \text{ (hr/yr)}
 \end{aligned} \tag{5.20}$$

$$U_{IE13} = U_{IE14} = 11.968 \times 10^{-3} \text{ (hr/yr)} \tag{5.21}$$

$$\begin{aligned}
 U_{IE12} &= 1 - \left[(1 - U_{IE13}) \times (1 - U_{BE_TFBB2}) \right] \\
 &= 1 - \left[(1 - 11.968 \times 10^{-3}) \times (1 - 0.002) \right] \\
 &= 13.944 \times 10^{-3} \text{ (hr/yr)}
 \end{aligned} \tag{5.22}$$

$$\begin{aligned}
 U_{IE9} &= 1 - \left[(1 - U_{IE11}) \times (1 - U_{I2}) \right] \\
 &= 1 - \left[(1 - 11.968 \times 10^{-3}) \times (1 - 13.944 \times 10^{-3}) \right] \\
 &= 25.745 \times 10^{-3} \text{ (hr/yr)}
 \end{aligned} \tag{5.23}$$

$$\begin{aligned}
 U_{IE7} &= U_{IE9} \times U_{IE8} \\
 &= 25.745 \times 10^{-3} \times 11.968 \times 10^{-3} = 0.308 \times 10^{-3} \text{ (hr/yr)}
 \end{aligned} \tag{5.24}$$

$$\begin{aligned}
 U_{IE5} &= 1 - \left[(1 - U_{IE7}) \times (1 - U_{BE_TFBB1}) \right] \\
 &= 1 - \left[(1 - 0.308 \times 10^{-3}) \times (1 - 0.002) \right] \\
 &= 2.308 \times 10^{-3} \text{ (hr/yr)}
 \end{aligned} \tag{5.25}$$

$$\begin{aligned}
U_{IE6} &= 1 - \left[(1 - U_{BE_PFCB4}) \times (1 - U_{BE_AFCB4}) \right] \\
&= 1 - \left[(1 - 0.008) \times (1 - 0.004) \right] \\
&= 11.968 \times 10^{-3} \text{ (hr/yr)}
\end{aligned} \tag{5.26}$$

$$\begin{aligned}
U_{IE4} &= 1 - \left[(1 - U_{IE6}) \times (1 - U_{IE5}) \right] \\
&= 1 - \left[(1 - 11.968 \times 10^{-3}) \times (1 - 2.308 \times 10^{-3}) \right] \\
&= 14.248 \times 10^{-3} \text{ (hr/yr)}
\end{aligned} \tag{5.27}$$

$$\begin{aligned}
U_{IE2} &= 1 - \left[(1 - U_{IE4}) \times (1 - U_{BE_TFT1}) \right] \\
&= 1 - \left[(1 - 14.248 \times 10^{-3}) \times (1 - 0.225) \right] \\
&= 0.236 \text{ (hr/yr)}
\end{aligned} \tag{5.28}$$

$$U_{IE3} = U_{IE2} = 0.236 \text{ (hr/yr)} \tag{5.29}$$

$$\begin{aligned}
U_{IE1} &= U_{IE2} \times U_{IE3} \\
&= 0.236 \times 0.236 = 55.696 \times 10^{-3} \text{ (hr/yr)}
\end{aligned} \tag{5.30}$$

$$\begin{aligned}
U_{TE} &= 1 - \left[(1 - U_{IE1}) \times (1 - U_{BE_TFBB2}) \right] \\
&= 1 - \left[(1 - 55.696 \times 10^{-3}) \times (1 - 0.002) \right] \\
&= 57.58 \times 10^{-3} \text{ (hr/yr)} = 57.58 \times 10^{-3} \times 60 = 3.455 \text{ (min/yr)}
\end{aligned} \tag{5.16}$$

Compared with the results from literature [2], the percentage change is 5.98%. As the percentage is more than 5%, this fault tree approach is not applicable for the substation reliability evaluation. The reliability evaluation of other configurations has also been investigated by using simple fault tree approach without power flow modeling technique based on literature [42,43]. But the percentage change is more than 5% which is not applicable as an alternative approach for substation reliability indices with respect to minimal cutset method. The main problem of the fault tree analysis (FTA) in this case study is that the transformer has highest impact on the reliability indice of the distribution substation. In this approach, the system reliability indices of substation configuration are dominantly affected by the components which have larger reliability indices.

Chapter 6

Conclusions and Future Works

This chapter presents the discussion and conclusions related to the works done in this thesis. The limitations of this thesis are also explained in this section and the future works related to this thesis are also discussed for the further researcher in this field.

6.1 Discussion and Conclusions

This thesis examined the reliability level of five different distribution substations by using the minimal cut set methods. Detailed calculations have been explained with equations and the minimal cut set considerations for each failure mode of the components. The calculation works are conducted by using Microsoft Excel software so that any student in this field can be utilized to understand this thesis works and to make further improvements related to reliability assessment of substation configurations. The reliability indices of the five substation configurations was calculated and compared with the results from literature [2, 14]. In the calculation of reliability indices of five substation configurations, the minimal cut sets are determined based on the failure modes of the components and many different approaches from literature [2,14,16,18] have been utilized to calculate the failure rates and unavailability of the substation configurations. Due to the few information related to the calculation works in those literature above, their results may have some errors and there are some percentage errors in the substation reliability indices calculations. But the results can show that the one-and-a-half breaker and double bus double breaker configurations have nearly the same reliability and the single bus have the worst reliability.

After calculating the substation reliability indices, the effect of interaction between the distribution substation and primary distribution system was determined by the

equations developed in [2]. The five types of distribution system such as link arrangement, basic radial, open loop, closed-loop and primary network system modified from RBTS Bus 4 are analyzed for the reliability assessment by the mathematical models developed in [2].

The composite distribution system reliability was then developed by combining the substation reliability, the interaction between the distribution substation and distribution system, and the primary distribution system reliability. The load point reliability indices of the composite distribution system were calculated and used as the input for determining the system reliability indices of the composite distribution system. From the load point reliability indices of composite distribution system, basic radial was found to be the worst-case scenario for the system. The unavailability of the composite distribution system related to the basic radial system is significantly higher than other four types of distribution system. On the other hand, primary network system had the best load point reliability. Next is link arrangement, closed-loop and open loop system respectively.

The load point reliability indices can only describe the general characteristic of the system performance and does not cover the severity of system failures. Thus, four system reliability indices were calculated by using the mathematical models and the results are summarized in both table and figure to illustrate the impact of substation reliability on composite distribution system. According to Fig. 4.8 to 4.11, the system reliability indices of composite distribution system are more affected by the primary distribution system reliability rather than substation reliability. The substation reliability indices have more impact on SAIFI than other three system reliability indices. Among the five types of distribution systems, the reliability indices of primary network system were not changed by the reliability indices of substation configurations. The basic radial system has the worst system reliability indices as there is no alternative emergency supply for the unfaulted load points after the fault has been cleared. Primary network system has the best system reliability indices except for CAIDI at which link arrangement is better than primary network system. Since the link arrangement system is supplied by three different substations, the alternative supply is provided to the load points located at the downstream of faulted sections after the fault has isolated from healthy part of the

system. Due to this ability to provide alternative supply from other distributions, the link arrangement had the second-best system reliability indices for SAIFI, SAIDI and AENS. The closed-loop system and open-loop system had nearly the same system reliability indices. The closed-loop system was slightly better than open-loop system because it was automatically clear the fault by opening the N/C circuit breaker and the feeder located at the ends of faulted sections.

All the calculation works were conducted by using Microsoft Excel software and the results calculated in this thesis have compared with those from [21] and percentage error was also described in Appendix D.

In this thesis, the substation reliability was evaluated by fault tree analysis (FTA) to investigate whether it could be applied for reliability assessment for distribution substations and compares the results with minimal cut set methods. Although unavailability calculation for single bus substation configuration showed the good result when compared to that from minimal cut set methods. For sectionalized bus, the error percentage is more than 5% and for the other types of substation configurations, the error percentage is very much greater than 5% as the impact of transformer had influenced the reliability indices of the substation configuration. When considering the effect of subtransmission line failure, the unavailability is dominantly affected by the subtransmission due to its high reliability indices. Therefore, FTA cannot provide the alternative approach to get the same results with minimal cut set approach.

6.2 Limitations

In this thesis works, the substation reliability indices were evaluated without considering the effect of disconnectors and fuses connected in the system. Maintenance outage is not also used in the calculation process. Failure modes such as active or total failure overlapping total failure were considered as the second order overlapping failures. Reliability data of the components in the system are based on the RBTS Buss 4 system [3] and uses the values for the single weather data.

In the fault tree analysis, the stuck breaker condition is not considered as there is no usage in the literatures. The second order overlapping failure modes are also not considered in the calculation process of FTA.

6.3 Future Works

This thesis can extend to include the substation automation based on IEC61850 and the impact of substation automation on composite distribution system. The calculations of the substation reliability indices by using minimal cut set method have been compared with other methods such as Reliability Block Diagram (RBD), Monte Carlo simulation method and so on. The calculation of the reliability indices can be conducted by using other reliability software such as SUBREL, RISKSPECTRUM and compare the results for accuracy.

As the composite distribution system of this thesis was taken and modified from RBTS Bus 4, the reliability assessment of the composite distribution system can be extended to include the whole RBTS system in [4].

By using the same concepts used in this thesis works, the mathematical models for the practical distribution system can be developed and the reliability assessment can be conducted for the system reliability.

In this thesis, only four system reliability indices are calculated to illustrate the detailed calculation process and to compare with the results from [2]. This can extend by calculating more system reliability indices such as Average service availability index (ASAI), Average service unavailability index (ASUI), Energy not supplied index (ENS), Average customer curtailment index, (ACCI).

Bibliography

- [1] R. Billinton and R. N. Allan, *Reliability evaluation of power systems, 2nd Edition*. New York: Plenum Press, 1996.
- [2] T.-F. Tsao and H.-C. Chang, "Composite reliability evaluation model for different types of distribution systems," *IEEE Transactions on power systems*, vol. 18, pp. 924-930, 2003.
- [3] Allan, Ronald N., et al. "A reliability test system for educational purposes-basic distribution system data and results." *IEEE Transactions on Power systems* 6.2 (1991): 813-820.
- [4] Billinton, Roy, and Satish Jonnavithula. "A test system for teaching overall power system reliability assessment." *IEEE Transactions on Power Systems*.
- [5] Billinton, Roy, and Ronald Norman Allan. *Reliability evaluation of engineering systems*. New York: Plenum press, 1992.
- [6] Grigg, Cliff, et al. "The IEEE reliability test system-1996. A report prepared by the reliability test system task force of the application of probability methods subcommittee." *IEEE Transactions on power systems* 14.3 (1999): 1010-1020.
- [7] Billinton, Roy, et al. "A reliability test system for educational purposes-basic results." *IEEE Transactions on Power Systems* 5.1 (1990): 319-325.
- [8] Billinton, Roy, et al. "A reliability test system for educational purposes-basic data." *IEEE Transactions on Power Systems* 4.3 (1989): 1238-1244.
- [9] P. H. Yau, "Generation System Reliability Evaluations with Intermittent Renewables," *Master theses, university of strathclyde*, 2006.
- [10] Retterath, Brad, A. A. Chowdhury, and S. S. Venkata. "Decoupled substation reliability assessment." *International Journal of Electrical Power & Energy Systems* 27.9 (2005): 662-668.
- [11] Billinton R, Li W. Reliability assessment of electric power systems using Monte Carlo methods. Plenum Press; 1994.
- [12] Billinton, R., and E. Wojczynski. "Distributional variation of distribution system reliability indices." *IEEE Transactions on Power Apparatus and Systems* 11 (1985): 3151-3160.

- [13] Billinton, Roy, and Peng Wang. "Teaching distribution system reliability evaluation using Monte Carlo simulation." *IEEE Transactions on Power Systems* 14.2 (1999): 397-403.
- [14] D. Nack, "Reliability of substation configurations," *Iowa State University*, vol. 7, 2005.
- [15] V. V. Vadlamudi, O. Gjerde, and G. H. Kjølle, *The impact of protection systems on power system reliability*, Version 1.0. ed. vol. TR A7439. Trondheim: SINTEF Energy Research, 2014.
- [16] Nosrati, Kamyar. "Substation reliability analysis using PSS/E." (2011).
- [17] Nighot, Rajesh U. *Incorporating substation and switching station related outages in composite system reliability evaluation*. Diss. 2003. [Online]. Available: <http://www.collectionscanada.gc.ca/obj/s4/f2/dsk3/SSU/TC-SSU-09292005132530.pdf>
- [18] Grover, M. S., and R. Billinton. "A computerized approach to substation and switching station reliability evaluation." *IEEE Transactions on Power Apparatus and Systems* 5 (1974): 1488-1497
- [19] Raesaar, P., E. Tiigimagi, and J. Valtin. "Simplified assessment of substation-originated failures in analysis of transmission system reliability." *Oil Shale* 24.2 (2007): 308.
- [20] Z. Liu, "Reliability analysis of breaker arrangements in high voltage stations: A fault tree approach," 2008.
- [21] Volkanovski, Andrija, Marko Čepin, and Borut Mavko. "Application of the fault tree analysis for assessment of power system reliability." *Reliability Engineering & System Safety* 94.6 (2009): 1116-1127.
- [22] Hong, Ying-Yi, Lun-Hui Lee, and Heng-Hsing Cheng. "Reliability assessment of protection system for switchyard using fault-tree analysis." *Power System Technology, 2006. PowerCon 2006. International Conference on*. IEEE, 2006.
- [23] Rahman, Fariz Abdul, et al. "Application of fault tree analysis for customer reliability assessment of a distribution power system." *Reliability Engineering & System Safety* 111 (2013): 76-85.

- [24] Scheer, Gary W., and David J. Dolezilek. "Comparing the reliability of Ethernet network topologies in substation control and monitoring networks." *Western Power Delivery Automation Conference, Spokane, Washington*. 2000.
- [25] F. Wang, B. W. Tuinema, M. Gibescu, and M. A. van der Meijden, "Reliability evaluation of substations subject to protection system failures," in *PowerTech (POWERTECH), 2013 IEEE Grenoble, 2013*, pp. 1-6.
- [26] Hajian-Hoseinabadi, Hamze. "Impacts of automated control systems on substation reliability." *IEEE Transactions on Power Delivery* 26.3 (2011): 1681-1691.
- [27] Hajian-Hoseinabadi, Hamze. "Reliability and component importance analysis of substation automation systems." *International Journal of Electrical Power & Energy Systems* 49 (2013): 455-463.
- [28] Zhang, Peichao, Levi Portillo, and Mladen Kezunovic. "Reliability and component importance analysis of all-digital protection systems." *Power Systems Conference and Exposition, 2006. PSCE'06. 2006 IEEE PES*. IEEE, 2006.
- [29] Zhang, Yan, Alex Sprintson, and Chanan Singh. "An integrative approach to reliability analysis of an IEC 61850 digital substation." *Power and Energy Society General Meeting, 2012 IEEE*. IEEE, 2012.
- [30] Brown, Richard Eric, et al. "Distribution system reliability assessment using hierarchical Markov modeling." *IEEE Transactions on Power Delivery* 11.4 (1996): 1929-1934.
- [31] Jiang, Kai, and Chanan Singh. "Reliability modeling of all-digital protection systems including impact of repair." *IEEE Transactions on Power Delivery* 25.2 (2010): 579-587.
- [32] P. Kundur, J. Paserba, V. Ajjarapu, G. Andersson, A. Bose, C. Canizares, *et al.*, "Definition and classification of power system stability," vol. 19, pp. 1387-1401, 2004.
- [33] R. Billinton. And R. N. Allan, *Reliability Evaluation of Engineering Systems: Concepts and Techniques*, Plenum Publishing, New York, 1983.
- [34] X. Xu, F. Dong, L. Huang, and B. P. Lam, "Modeling and simulation of substation related outages in power flow analysis," in *Power System Technology (POWERCON), 2010 International Conference on, 2010*, pp. 1-5.

- [35] Zaw Win Htun, "Reliability Evaluation of Substation Configurations and Effect of Protection System Failures" (Jan, 2017)
- [36] "Design guide for rural substations," in *Design guide for rural substations.* -, ed. Washington]: Washington]: Power Supply and Engineering Standards Division, Rural Elect. Admin., U.S. Dept. of Agriculture, 1978.
- [37] J. D. McDonald, *Electric Power Substations Engineering, Third Edition*, 3 ed., 2012.
- [38] R. Billinton, R. J. Ringlee, A. J. Wood, I. Xplore, and M. I. T. Press. (2003). *Powersystem reliability calculations.*
- [39] Bangalore, Pramod. "Development of test system for distribution system reliability analysis, integration of electric vehicles into the distribution system." (2011). [Online]. Available: <http://publications.lib.chalmers.se/records-/fulltext/152475.pdf>
- [40] Grigg, Cliff, et al. "The IEEE reliability test system-1996. A report prepared by the reliability test system task force of the application of probability methods subcommittee." *IEEE Transactions on power systems* 14.3 (1999): 1010-1020.
- [41] Nosrati, Kamyar. "Substation reliability analysis using PSS / E." (2011).
- [42] W. Vesely, M. Stamatelatos, J. Dugan, J. Fragola, J. Minarick III, and J. Railsback, "Fault tree handbook with Aerospace Applications version 1.1," *NASA Office of Safety and Mission Assurance, NASA HQ*, 2002.
- [43] Hong, Ying-Yi, Lun-Hui Lee, and Heng-Hsing Cheng. "Reliability assessment of protection system for switchyard using fault-tree analysis." *Power System Technology, 2006. PowerCon 2006. International Conference on.* IEEE, 2006.

Appendix A

Basic Distribution System Data of RBTS Bus 4

In this appendix section A, the peak loads, feeder types and lengths, customer data, loading data and, reliability and system data are presented. These data are adapted from reference [31].

Table A.1: Peak Loads in RBTS Bus 4 [31]

Customer type	Peak loads, MW
Residential	19
Small user	16.3
Government/institutions	-
Commercial	4.7
Total	40

Table A.2: Feeder Types and Lengths in RBTS Bus 4 [31]

Feeder type	Length, km	Feeder Section Number
1	0.6	2 6 10 14 17 21 25 28 30 34 38 41 43 46 49 51 55 58 61 64 67
2	0.75	1 4 7 9 12 16 19 22 24 27 29 32 35 37 40 42 45 48 50 53 56 60 63 65
3	0.8	3 5 8 11 13 15 18 20 23 26 31 33 36 39 44 47 52 54 57 59 62 66

Table A.3: Customer Data in RBTS Bus 4 [31]

Number of load points	Load points	Customer type	Load level per load point		Number of customers
			Average	Peak	
15	1-4, 11-13, 18-21, 32-35	Residential	0.545	0.8869	220
7	5, 14, 15, 22, 23, 36, 37	Residential	0.5	0.8137	200
7	8, 10, 26-30	Small user	1	1.63	1
2	9,31	Small user	1	2.445	1
7	6, 7, 16, 17, 24, 25, 38	Commercial	0.415	0.6714	10
Total			24.58	40.00	4779

Table A.4: Load Data in RBTS Bus 4 [31]

Feeder number	Load points	Feeder load, MW		Number of customers
		Average	Peak	
F1	1-7	3.51	5.704	1100
F2	8-10	3.5	5.705	3
F3	11-17	3.465	5.63	1080
SP1 TOTALS		10.475	17.04	2183
F4	18-25	4.01	6.518	1300
F5	26-28	3.0	4.89	3
SP2 TOTALS		7.01	11.408	1303
F6	29-31	3.5	5.705	3
F7	32-38	3.595	5.847	1290
SP3 TOTALS		7.095	11.552	1293
BUS 4 TOTALS		24.58	40	4779

Table A.4: Reliability and System Data of RBTS Bus 4 [31]

Components	Total failure rate, λ_T (f/yr)	Active failure rate, λ_A (f/yr)	Maintenance outage rate, λ_M (out/yr)	Repair time, MTTR (hr)	Replacement time by a spare, r_p (hr)	Maintenance outage time, MTTM (hr)	Switching time, s (hr)
Transformer (33/11)	0.015	0.015	1		15	120	1
Transformer (11/0.415)	0.015	0.015	-	200	10		1
Breakers (11kV)	0.006	0.004	1	4	-	72	1
Busbars (11kV)	0.001	0.001	1	2		8	1
Line (33kV)	0.046	0.046	0.5	8	-	8	2
Line (11Kv)	0.065	0.065	-	-	5	-	1

Appendix B

Calculation Results for Reliability Indices of Five Distribution Substations

In this appendix section B, the calculation results of reliability indices (λ , U, r) of five distribution substations are presented. In the calculation process, the incoming lines L1 and L2 are considered as 100% reliable. The calculation works are done by using Microsoft Excel software and attached together with this thesis.

Table B.1: Failure rates of Single Bus Configuration

Overlapping Failures		Total Failures		Active Failure		Active Failure + Stuck Breaker	
B1+B2 (L)	7.13576E-05	BB1 (L)	0.001	B1 (L)	0.004	T1+B3 (L)	0.015
B3+B4 (L)	7.13576E-05	BB2 (L)	0.001	B2 (L)	0.004	T2+B4 (L)	0.015
B3+T2 (L)	1.77204E-04			B3 (L)	0.004		
B4+T1 (L)	1.77204E-04			B4 (L)	0.004		
T1+T2 (L)	4.40090E-04						
B1+B3 (L)	4.76425E-05						
B1+B4 (L)	4.76425E-05						
B3+B2 (L)	4.76425E-05						
B2+B4 (L)	4.76425E-05						
B1+T2 (L)	1.18310E-04						
B1+T1 (L)	1.18310E-04						
B2+T2 (L)	1.18310E-04						
B2+T1 (L)	1.18310E-04						
λ_o	1.60102E-03	λ_t	0.002	λ_a	0.016	λ_s	0.03
$\lambda = \lambda_o + \lambda_t + \lambda_a + \lambda_s$					0.049601025 (f/yr)		

Table B.2: Unavailability of Single Bus Configuration

Overlapping Failures		Total Failures		Active Failure		Active Failure + Stuck Breaker	
B1+B2 (U)	1.42715E-04	BB1 (U)	0.002	B1 (U)	0.004	T1+B3 (U)	0.015
B3+B4 (U)	1.42715E-04	BB2 (U)	0.002	B2 (U)	0.004	T2+B4 (U)	0.015
B3+T2 (U)	5.59593E-04			B3 (U)	0.004		
B4+T1 (U)	5.59593E-04			B4 (U)	0.004		
T1+T2 (U)	3.30067E-03						
B1+B3 (U)	9.52851E-05						
B1+B4 (U)	9.52851E-05						
B3+B2 (U)	9.52851E-05						
B2+B4 (U)	9.52851E-05						
B1+T2 (U)	3.73611E-04						
B1+T1 (U)	3.73611E-04						
B2+T2 (U)	3.73611E-04						
B2+T1 (U)	3.73611E-04						
U_o	1.60102E-03	U_t	0.004	U_a	0.016	U_s	0.03
U=U_o+U_t+U_a+U_s		5.65809E-02 hr/yr (or) 3.39485E+00 min/yr					

Table B.3: Failure rates of Sectionalized Single Bus Configuration

Overlapping Failures		Total Failures		Active Failure		Active Failure + Stuck Breaker	
B1+B2 (L)	7.13576E-05	BB3 (L)	0.001	B3 (L)	0.004	T1+B4 (L)	0.015
B4+B5 (L)	7.13576E-05			B4 (L)	0.004	T2+B5 (L)	0.015
B4+T2 (L)	1.77204E-04			B5 (L)	0.004		
B5+T1 (L)	1.77204E-04						
T1+T2 (L)	4.40090E-04						
BB1+BB2 (L)	1.99700E-06						
BB1+B5 (L)	1.19373E-05						
BB2+B4 (L)	1.19373E-05						
BB1+T2 (L)	2.96429E-05						
BB2+T1 (L)	2.96429E-05						
BB1+B2	1.19373E-05						
BB2+B1	1.19373E-05						
B1+B3	7.13576E-05						
B2+B3	7.13576E-05						
B2+B4	7.13576E-05						
B1+B5	7.13576E-05						
B3+B4	7.13576E-05						
B3+B5	7.13576E-05						
B3+BB1	1.19373E-05						
B3+BB2	1.19373E-05						
B1+T2	1.77204E-04						
B2+T1	1.77204E-04						
B3+T1	1.77204E-04						
B3+T2	1.77204E-04						
λ_o	2.20708E-03	λ_t	1.0E-03	λ_a	1.2E-02	λ_s	0.03
$\lambda = \lambda_o + \lambda_t + \lambda_a + \lambda_s$					4.52071E-02 (f/yr)		

Table B.4: Unavailability of Sectionalized Single Bus Configuration

Overlapping Failures		Total Failures		Active Failure		Active Failure + Stuck Breaker	
B1+B2 (U)	1.42715E-04	BB3 (U)	2.0E-03	B3 (U)	4.0E-03	T1+B4 (U)	1.5E-02
B4+B5 (U)	1.42715E-04			B4(U)	4.0E-03	T2+B5 (U)	1.5E-02
B4+T2 (U)	5.59593E-04			B5 (U)	4.0E-03		
B5+T1 (U)	5.59593E-04						
T1+T2 (U)	3.30067E-03						
BB1+BB2 (U)	1.99700E-06						
BB1+B5 (U)	1.59163E-05						
BB2+B4 (U)	1.59163E-05						
BB1+T2 (U)	5.23110E-05						
BB2+T1 (U)	5.23110E-05						
BB1+B2 (U)	1.59163E-05						
BB2+B1 (U)	1.59163E-05						
B1+B3	1.42715E-04						
B2+B3	1.42715E-04						
B2+B4	1.42715E-04						
B1+B5	1.42715E-04						
B3+B4	1.42715E-04						
B3+B5	1.42715E-04						
B3+BB1	1.59163E-05						
B3+BB2	1.59163E-05						
B1+T2	5.59593E-04						
B2+T1	5.59593E-04						
B3+T1	5.59593E-04						
B3+T2	5.59593E-04						
U_o	8.00207E-03	U_t	2.0E-03	U_a	1.2E-02	U_s	3.0E-02
U=U_o+U_t+U_a+U_s		5.20021E-02 hr/yr (or) 3.12012 min/yr					

Table B.5: Failure rates of Double Bus One-and-a-Half Breaker Configuration

Overlapping Failures		Total Failures	
B1+B2 (L)	3.18091E-05	BB3 (L)	0.001
B4+B5 (L)	3.18091E-05		
B4+T1 (L)	1.18310E-04		
B5+T2 (L)	1.18310E-04		
T1+T2 (L)	4.40090E-04		
B1+B4 (L)	4.76425E-05		
B1+B6 (L)	3.18091E-05		
BB1+T2 (L)	2.96429E-05		
BB2+T1 (L)	2.96429E-05		
B2+B3 (L)	4.76425E-05		
B2+B5 (L)	3.18091E-05		
B3+B6 (L)	3.18091E-05		
B3+B4 (L)	7.13576E-05		
B5+B6 (L)	3.18091E-05		
BB1+T1 (L)	2.96429E-05		
BB2+T2 (L)	2.96429E-05		
B2+T1 (L)	1.77204E-04		
B1+T2 (L)	1.77204E-04		
B3+T2 (L)	1.77204E-04		
B6+T1 (L)	1.77204E-04		
λ_o	1.86160E-03	λ_t	1.00000E-03
$\lambda = \lambda_o + \lambda_t + \lambda_a + \lambda_s$		2.86160E-03 (f/yr)	

Table B.6: Unavailability of Double Bus One-and-a-Half Breaker Configuration

Overlapping Failures		Total Failures	
B1+B2 (U)	6.36182E-05	BB3 (U)	2.00000E-03
B4+B5 (U)	6.36182E-05		
B4+T2 (U)	3.73611E-04		
B5+T1 (U)	3.73611E-04		
T1+T2 (U)	3.30067E-03		
B1+B4 (L)	9.52851E-05		
B1+B6 (L)	6.36182E-05		
BB1+T2 (U)	5.23110E-05		
BB2+T1 (U)	5.23110E-05		
B2+B3 (U)	9.52851E-05		
B2+B5 (U)	6.36182E-05		
B3+B6 (U)	6.36182E-05		
B3+B4 (U)	1.42715E-04		
B5+B6 (U)	6.36182E-05		
BB1+T1 (U)	5.23110E-05		
BB2+T2 (U)	5.23110E-05		
B2+T1 (U)	5.59593E-04		
B1+T2 (U)	5.59593E-04		
B3+T2 (U)	5.59593E-04		
B6+T1 (U)	5.59593E-04		
U_o	7.21051E-03	U_t	2.00000E-03
U=U_o+U_t+U_a+U_s	9.21051E-03 hr/yr (or) 5.52630E-01 min/yr		

Table B.7: Failure rates of Double Bus Double Breaker Configuration

Overlapping Failures		Total Failures	
B1+B5 (L)	3.18091E-05	BB3 (L)	0.001
B1+B6 (L)	3.18091E-05		
B1+B7 (L)	3.18091E-05		
B1+B8 (L)	3.18091E-05		
B2+B5 (L)	3.18091E-05		
B2+B6 (L)	3.18091E-05		
B2+B7 (L)	4.76425E-05		
B2+B8 (L)	3.18091E-05		
B3+B5 (L)	3.18091E-05		
B3+B6 (L)	4.76425E-05		
B3+B7 (L)	3.18091E-05		
B3+B8 (L)	3.18091E-05		
B4+B5 (L)	3.18091E-05		
B4+B6 (L)	3.18091E-05		
B4+B7 (L)	3.18091E-05		
B4+B8 (L)	3.18091E-05		
BB1+B5 (L)	7.97009E-06		
BB1+B6 (L)	7.97009E-06		
BB1+B7 (L)	7.97009E-06		
BB1+B8 (L)	7.97009E-06		
BB2+B1 (L)	7.97009E-06		
BB2+B2 (L)	7.97009E-06		
BB2+B3 (L)	7.97009E-06		
BB2+B4 (L)	7.97009E-06		
BB1+BB2 (L)	1.99700E-06		
T1+T2(L)	4.40090E-04		
T1+B3(L)	1.77204E-04		
T1+B7(L)	1.77204E-04		
T2+B2(L)	1.77204E-04		
T2+B6(L)	1.77204E-04		
BB3+B5 (L)	1.19373E-05		
BB3+B6 (L)	1.19373E-05		
BB3+B7 (L)	1.19373E-05		
BB3+B8 (L)	1.19373E-05		
BB3+B1 (L)	1.19373E-05		
BB3+B2 (L)	1.19373E-05		
BB3+B3 (L)	1.19373E-05		
BB3+B4 (L)	1.19373E-05		
BB3+BB1 (L)	1.99700E-06		

BB3+BB2 (L)	1.99700E-06		
BB3+T1 (L)	2.96429E-05		
BB3+T2 (L)	2.96429E-05		
λ_o	1.91406E-03	λ_t	1.00000E-03
$\lambda=\lambda_o+\lambda_t+\lambda_a+\lambda_s$		2.91406E-03 (f/yr)	

Table B.8: Unavailability of Double Bus Double Breaker Configuration

Overlapping Failures		Total Failures	
B1+B5 (U)	6.36182E-05	BB3 (U)	2.00000E-03
B1+B6 (U)	6.36182E-05		
B1+B7 (U)	6.36182E-05		
B1+B8 (U)	6.36182E-05		
B2+B5 (U)	6.36182E-05		
B2+B6 (U)	6.36182E-05		
B2+B7 (U)	9.52851E-05		
B2+B8 (U)	6.36182E-05		
B3+B5 (U)	6.36182E-05		
B3+B6 (U)	9.52851E-05		
B3+B7 (U)	6.36182E-05		
B3+B8 (U)	6.36182E-05		
B4+B5 (U)	6.36182E-05		
B4+B6 (U)	6.36182E-05		
B4+B7 (U)	6.36182E-05		
B4+B8 (U)	6.36182E-05		
BB1+B5 (U)	1.06268E-05		
BB1+B6 (U)	1.06268E-05		
BB1+B7 (U)	1.06268E-05		
BB1+B8 (U)	1.06268E-05		
BB2+B1 (U)	1.06268E-05		
BB2+B2 (U)	1.06268E-05		
BB2+B3 (U)	1.06268E-05		
BB2+B4 (U)	1.06268E-05		
BB1+BB2 (U)	1.99700E-06		
T1+T2(U)	3.30067E-03		
T1+B3(U)	5.59593E-04		
T1+B7(U)	5.59593E-04		
T2+B2(U)	5.59593E-04		
T2+B6(U)	5.59593E-04		
BB3+B5 (U)	1.59163E-05		
BB3+B6 (U)	1.59163E-05		

BB3+B7 (U)	1.59163E-05		
BB3+B8 (U)	1.59163E-05		
BB3+B1 (U)	1.59163E-05		
BB3+B2 (U)	1.59163E-05		
BB3+B3 (U)	1.59163E-05		
BB3+B4 (U)	1.59163E-05		
BB3+BB1 (U)	1.99700E-06		
BB3+BB2 (U)	1.99700E-06		
BB3+T1 (U)	5.23110E-05		
BB3+T2 (U)	5.23110E-05		
U_o	6.94323E-03	U_t	2.00000E-03
U=U_o+U_t+U_a+U_s	8.94323E-03 hr/yr (or) 5.36594E-01 min/yr		

Table B.9: Failure rates of Ring Configuration

Overlapping Failures		Total Failures		Active Failure	
B1+B2 (L)	7.13576E-05	BB5 (L)	0.001	B2 (L)	0.004
B1+B3 (L)	7.13576E-05			B3 (L)	0.004
B1+B4 (L)	7.13576E-05				
B2+B3 (L)	7.13576E-05				
B2+B4 (L)	7.13576E-05				
B3+B4 (L)	7.13576E-05				
BB1+B2 (L)	1.19373E-05				
BB1+B4 (L)	1.19373E-05				
BB2+B3 (L)	1.19373E-05				
BB2+B4 (L)	1.19373E-05				
BB3+B1 (L)	1.19373E-05				
BB3+B3 (L)	1.19373E-05				
BB4+B1 (L)	1.19373E-05				
BB4+B2 (L)	1.19373E-05				
BB1+BB3 (L)	1.99700E-06				
BB2+BB4 (L)	1.99700E-06				
BB4+BB1 (L)	1.99700E-06				
BB3+BB2 (L)	1.99700E-06				
T1+T2(L)	4.40090E-04				
T1+B1(L)	1.77204E-04				
T1+B2(L)	1.77204E-04				
T1+B3(L)	1.77204E-04				
T1+B4(L)	1.77204E-04				
T2+B1(L)	1.77204E-04				
T2+B2(L)	1.77204E-04				

T2+B3(L)	1.77204E-04				
T2+B4(L)	1.77204E-04				
T1+BB1(L)	2.96429E-05				
T1+BB2(L)	2.96429E-05				
T1+BB3(L)	2.96429E-05				
T1+BB4(L)	2.96429E-05				
T2+BB1(L)	2.96429E-05				
T2+BB2(L)	2.96429E-05				
T2+BB3(L)	2.96429E-05				
T2+BB4(L)	2.96429E-05				
BB5+B1 (L)	1.19373E-05				
BB5+B2 (L)	1.19373E-05				
BB5+B2 (L)	1.19373E-05				
BB5+B2 (L)	1.19373E-05				
BB5+T1 (L)	2.96429E-05				
BB5+T2 (L)	2.96429E-05				
BB5+BB1 (L)	1.99700E-06				
BB5+BB2 (L)	1.99700E-06				
BB5+BB3 (L)	1.99700E-06				
BB5+BB4 (L)	1.99700E-06				
λ_o	2.74152E-03	λ_t	1.00E-03	λ_a	8.0E-03
$\lambda=\lambda_o+\lambda_t+\lambda_a+\lambda_s$			1.17415E-02 (f/yr)		

Table B.10: Unavailability of Ring Configuration

Overlapping Failures		Total Failures		Active Failure	
B1+B2 (U)	1.42715E-04	BB5 (U)	2.0E-03	B2 (U)	4.0E-03
B1+B3 (U)	1.42715E-04			B3 (U)	4.0E-03
B1+B4 (U)	1.42715E-04				
B2+B3 (U)	1.42715E-04				
B2+B4 (U)	1.42715E-04				
B3+B4 (U)	1.42715E-04				
BB1+B2 (U)	1.59163E-05				
BB1+B4 (U)	1.59163E-05				
BB2+B3 (U)	1.59163E-05				
BB2+B4 (U)	1.59163E-05				
BB3+B1 (U)	1.59163E-05				
BB3+B3 (U)	1.59163E-05				
BB4+B1 (U)	1.59163E-05				
BB4+B2 (U)	1.59163E-05				
BB1+BB3(U)	1.99700E-06				

BB2+BB4(U)	1.99700E-06				
BB4+BB1(U)	1.99700E-06				
BB3+BB2(U)	1.99700E-06				
T1+T2(U)	3.30067E-03				
T1+B1(U)	5.59593E-04				
T1+B2(U)	5.59593E-04				
T1+B3(U)	5.59593E-04				
T1+B4(U)	5.59593E-04				
T2+B1(U)	5.59593E-04				
T2+B2(U)	5.59593E-04				
T2+B3(U)	5.59593E-04				
T2+B4(U)	5.59593E-04				
T1+BB1(U)	3.12714E-04				
T1+BB2(U)	3.12714E-04				
T1+BB3(U)	3.12714E-04				
T1+BB4(U)	3.12714E-04				
T2+BB1(U)	3.12714E-04				
T2+BB2(U)	3.12714E-04				
T2+BB3(U)	3.12714E-04				
T2+BB4(U)	5.23110E-05				
BB5+B1 (L)	1.59163E-05				
BB5+B2 (L)	1.59163E-05				
BB5+B2 (L)	1.59163E-05				
BB5+B2 (L)	1.59163E-05				
BB5+T1 (L)	3.12714E-04				
BB5+T2 (L)	3.12714E-04				
BB5+BB1 (L)	1.99700E-06				
BB5+BB2 (L)	1.99700E-06				
BB5+BB3 (L)	1.99700E-06				
BB5+BB4 (L)	1.99700E-06				
U_o	1.17074E-02	U_t	2.00000E-03	U_a	8.0E-03
U=U_o+U_t+U_a+U_s		2.17074E-02 hr/yr (or) 1.30244 min/yr			

Appendix C

Calculation Results for Load Point Reliability Indices of Five Distribution System

In this appendix section C, the calculation results of reliability indices contributed by primary protection, back up protection and primary distribution system are described to give clear illustration. The calculation results of reliability indices ($\lambda_{LP,i}, U_{LP,i}$) for five distribution substations with respect to five different distribution substation configurations are also presented. The calculation results are also compared with the values from the reference [21] and described as the percentage changes. The calculation works are done by using Microsoft Excel software and attached together with this thesis.

Table C.1: Calculation Results of Reliability Indices Contributed by Primary Protection, Back up Protection and Primary Distribution System for Five Configurations

	Link arrangement system	Close loop system	Basic radial system	Open loop system	Primary network system	
λ (CB, i)	1.200E-02	2.800E-02	2.800E-02	2.800E-02	8.000E-03	
U (CB, i)	7.200E-01	1.680E+00	2.400E+00	1.680E+00	4.800E-01	
λ (stuck, i)	2.356E-02	6.224E-02	6.224E-02	6.224E-02	0.000E+00	
U (stuck, i)	1.414E+00	3.734E+00	3.734E+00	3.734E+00	0.000E+00	
λ (F, i)	1.970E-01	1.950E-01	1.970E-01	1.970E-01	1.950E-01	LP10
U (F, i)	2.430E+01	2.418E+01	5.898E+01	2.430E+01	2.418E+01	
λ (F, i)	1.93750E-01	1.91750E-01	1.93750E-01	1.93750E-01	1.91750E-01	LP9
U (F, i)	2.33250E+01	2.32050E+01	4.86450E+01	2.33250E+01	2.32050E+01	
λ (F, i)	1.84000E-01	1.82000E-01	1.84000E-01	1.84000E-01	1.82000E-01	LP8
U (F, i)	2.04000E+01	2.02800E+01	3.32400E+01	2.04000E+01	2.02800E+01	

Table C.1: Calculation Results of Load Point Reliability Indices for Five Distribution System with respect to Substation Configuration 'a'

CALCULATION RESULT	Basic radial system	Link arrangement system	Open loop system	Close loop system	Primary network system	
λ (LPi)	3.361E-01	2.815E-01	3.361E-01	3.341E-01	0.203	LP10
U (LPi)	6.864E+01	2.996E+01	3.324E+01	3.312E+01	24.66	
λ (LPi)	3.329E-01	2.782E-01	3.329E-01	3.309E-01	0.19975	LP9
U (LPi)	5.831E+01	2.899E+01	3.227E+01	3.215E+01	23.685	
λ (LPi)	3.231E-01	2.685E-01	3.231E-01	3.211E-01	0.19	LP8
U (LPi)	4.290E+01	2.606E+01	2.934E+01	2.922E+01	20.76	

Table C.2: Load Point Reliability Indices for Five Distribution System with respect to Substation Configuration 'a' from reference [21]

REFERENCE RESULT	Basic radial system	Link arrangement system	Open loop system	Close loop system	Primary network system	
λ (LPi)	0.341	0.282	0.341	0.339	0.203	LP10
U (LPi)	69.43	29.4	34.03	33.91	24.66	
λ (LPi)	0.338	0.279	0.338	0.336	0.2	LP9
U (LPi)	59.09	28.43	33.05	32.93	23.69	
λ (LPi)	0.328	0.269	0.328	0.326	0.19	LP8
U (LPi)	43.69	25.5	30.13	30.01	20.76	

Table C.3: Percentage Changes between Calculation Results and Reference Values for Load Point Reliability Indices from Table (C.1) and Table (C.3)

PERCENTAGE CHANGES	Basic radial system	Link arrangement system	Open loop system	Close loop system	Primary network system	
λ (LPi)	1.425953079	0.190602837	1.425953079	1.434365782	-1.36727E-14	LP10
U (LPi)	1.131715397	-1.917517007	2.308992066	2.317163079	0	
λ (LPi)	1.512573964	0.282258065	1.512573964	1.521577381	0.125	LP9
U (LPi)	1.321289558	-1.9653535	2.362329803	2.370938354	0.021105952	
λ (LPi)	1.482469512	0.199814126	1.482469512	1.491564417	0	LP8
U (LPi)	1.798466468	-2.210784314	2.607865914	2.618293902	0	

Table C.4: Calculation Results of Load Point Reliability Indices for Five Distribution System with respect to Substation Configuration 'b'

CALCULATION RESULT	Basic radial system	Link arrangement system	Open loop system	Close loop system	Primary network system	
λ (LPi)	3.325E-01	2.779E-01	3.325E-01	3.305E-01	0.203	LP10
U (LPi)	6.837E+01	2.969E+01	3.297E+01	3.285E+01	24.66	
λ (LPi)	3.293E-01	2.746E-01	3.293E-01	3.273E-01	0.19975	LP9
U (LPi)	5.804E+01	2.872E+01	3.200E+01	3.188E+01	23.685	
λ (LPi)	3.195E-01	2.649E-01	3.195E-01	3.175E-01	0.19	LP8
U (LPi)	4.263E+01	2.579E+01	2.907E+01	2.895E+01	20.76	

Table C.5: Load Point Reliability Indices for Five Distribution System with respect to Substation Configuration 'b' from reference [21]

REFERENCE RESULT	Basic radial system	Link arrangement system	Open loop system	Close loop system	Primary network system	
λ (LPi)	0.333	0.274	0.333	0.331	0.203	LP10
U (LPi)	68.61	28.9	33.21	33.09	24.66	
λ (LPi)	0.33	0.27	0.33	0.328	0.2	LP9
U (LPi)	58.27	27.93	32.23	32.11	23.69	
λ (LPi)	0.32	0.261	0.32	0.318	0.19	LP8
U (LPi)	42.87	25	29.31	29.19	20.76	

Table C.6: Percentage Changes between Calculation Results and Reference Values for Load Point Reliability Indices from Table (C.4) and Table (C.5)

PERCENTAGE CHANGES	Basic radial system	Link arrangement system	Open loop system	Close loop system	Primary network system	
λ (LPi)	0.138888889	-1.409671533	0.138888889	0.139728097	-1.36727E-14	LP10
U (LPi)	0.343608803	-2.746539792	0.709876543	0.712450892	0	
λ (LPi)	0.215909091	-1.708333333	0.215909091	0.21722561	0.125	LP9
U (LPi)	0.396001373	-2.824024347	0.715947875	0.718623482	0.021105952	
λ (LPi)	0.14453125	-1.479885057	0.14453125	0.145440252	0	LP8
U (LPi)	0.549918358	-3.175	0.804332992	0.807639603	0	

Table C.7: Calculation Results of Load Point Reliability Indices for Five Distribution System with respect to Substation Configuration 'c'

CALCULATION RESULT	Basic radial system	Link arrangement system	Open loop system	Close loop system	Primary network system	
λ (LPi)	2.902E-01	2.356E-01	2.902E-01	2.882E-01	0.203	LP10
U (LPi)	6.567E+01	2.699E+01	3.027E+01	3.015E+01	24.66	
λ (LPi)	2.870E-01	2.323E-01	2.870E-01	2.850E-01	0.19975	LP9
U (LPi)	5.534E+01	2.602E+01	2.930E+01	2.918E+01	23.685	
λ (LPi)	2.772E-01	2.226E-01	2.772E-01	2.752E-01	0.19	LP8
U (LPi)	3.993E+01	2.309E+01	2.637E+01	2.625E+01	20.76	

Table C.8: Load Point Reliability Indices for Five Distribution System with respect to Substation Configuration 'c' from reference [21]

REFERENCE RESULT	Basic radial system	Link arrangement system	Open loop system	Close loop system	Primary network system	
λ (LPi)	0.291	0.231	0.291	0.289	0.203	LP10
U (LPi)	65.73	26.36	30.33	30.21	24.66	
λ (LPi)	0.287	0.228	0.287	0.285	0.2	LP9
U (LPi)	55.4	25.39	29.36	29.24	23.69	
λ (LPi)	0.278	0.218	0.278	0.276	0.19	LP8
U (LPi)	39.99	22.46	26.43	26.31	20.76	

Table C.9: Percentage Changes between Calculation Results and Reference Values for Load Point Reliability Indices from Table (C.7) and Table (C.8)

PERCENTAGE CHANGES	Basic radial system	Link arrangement system	Open loop system	Close loop system	Primary network system	
λ (LPi)	0.258591065	-1.979437229	0.258591065	0.260380623	-1.36727E-14	LP10
U (LPi)	0.084816674	-2.404210926	0.183811408	0.184541543	0	
λ (LPi)	0.00087108	-1.895833333	0.00087108	0.000877193	0.125	LP9
U (LPi)	0.10965704	-2.476368649	0.206914169	0.207763338	0.021105952	
λ (LPi)	0.270683453	-2.097477064	0.270683453	0.272644928	0	LP8
U (LPi)	0.139409852	-2.821682992	0.210934544	0.211896617	0	

Table C.10: Calculation Results of Load Point Reliability Indices for Five Distribution System with respect to Substation Configuration 'd'

CALCULATION RESULT	Basic radial system	Link arrangement system	Open loop system	Close loop system	Primary network system	
λ (LPi)	2.929E-01	2.382E-01	2.929E-01	2.909E-01	0.203	LP10
U (LPi)	6.581E+01	2.713E+01	3.041E+01	3.029E+01	24.66	
λ (LPi)	2.897E-01	2.350E-01	2.897E-01	2.877E-01	0.19975	LP9
U (LPi)	5.548E+01	2.616E+01	2.944E+01	2.932E+01	23.685	
λ (LPi)	2.799E-01	2.252E-01	2.799E-01	2.779E-01	0.19	LP8
U (LPi)	4.007E+01	2.323E+01	2.651E+01	2.639E+01	20.76	

Table C.11: Load Point Reliability Indices for Five Distribution System with respect to Substation Configuration 'd' from reference [21]

REFERENCE RESULT	Basic radial system	Link arrangement system	Open loop system	Close loop system	Primary network system	
λ (LPi)	0.292	0.233	0.292	0.29	0.203	LP10
U (LPi)	65.79	26.47	30.39	30.27	24.66	
λ (LPi)	0.289	0.23	0.289	0.287	0.2	LP9
U (LPi)	55.46	25.49	29.42	29.3	23.69	
λ (LPi)	0.279	0.22	0.279	0.277	0.19	LP8
U (LPi)	40.05	22.57	26.49	26.37	20.76	

Table C.12: Percentage Changes between Calculation Results and Reference Values for Load Point Reliability Indices from Table (C.10) and Table (C.11)

PERCENTAGE CHANGES	Basic radial system	Link arrangement system	Open loop system	Close loop system	Primary network system	
λ (LPi)	-0.310787671	-2.245708155	-0.310787671	-0.312931034	-1.36727E-14	LP10
U (LPi)	-0.036859705	-2.507555723	-0.079795986	-0.080112322	0	
λ (LPi)	-0.227508651	-2.166304348	-0.227508651	-0.229094077	0.125	LP9
U (LPi)	-0.034709701	-2.623577874	-0.065431679	-0.065699659	0.021105952	
λ (LPi)	-0.325268817	-2.378409091	-0.325268817	-0.327617329	0	LP8
U (LPi)	-0.060549313	-2.940850687	-0.091543979	-0.091960561	0	

Table C.13: Calculation Results of Load Point Reliability Indices for Five Distribution System with respect to Substation Configuration 'e'

CALCULATION RESULT	Basic radial system	Link arrangement system	Open loop system	Close loop system	Primary network system	
λ (LPi)	3.046E-01	2.500E-01	3.046E-01	3.026E-01	0.203	LP10
U (LPi)	6.653E+01	2.785E+01	3.113E+01	3.101E+01	24.66	
λ (LPi)	3.014E-01	2.467E-01	3.014E-01	2.994E-01	0.19975	LP9
U (LPi)	5.620E+01	2.688E+01	3.016E+01	3.004E+01	23.685	
λ (LPi)	2.916E-01	2.370E-01	2.916E-01	2.896E-01	0.19	LP8
U (LPi)	4.079E+01	2.395E+01	2.723E+01	2.711E+01	20.76	

Table C.14: Load Point Reliability Indices for Five Distribution System with respect to Substation Configuration 'e' from reference [21]

REFERENCE RESULT	Basic radial system	Link arrangement system	Open loop system	Close loop system	Primary network system	
λ (LPi)	0.304	0.245	0.304	0.302	0.203	LP10
U (LPi)	66.5	27.17	31.1	30.98	24.66	
λ (LPi)	0.301	0.242	0.301	0.299	0.2	LP9
U (LPi)	56.17	26.19	30.13	30.01	23.69	
λ (LPi)	0.291	0.232	0.291	0.289	0.19	LP8
U (LPi)	40.76	23.27	27.2	27.08	20.76	

Table C.15: Percentage Changes between Calculation Results and Reference Values for Load Point Reliability Indices from Table (C.10) and Table (C.11)

PERCENTAGE CHANGES	Basic radial system	Link arrangement system	Open loop system	Close loop system	Primary network system	
λ (LPi)	-0.209703947	-2.025510204	-0.209703947	-0.211092715	-1.36727E-14	LP10
U (LPi)	-0.051503759	-2.516562385	-0.110128617	-0.110555197	0	
λ (LPi)	-0.128737542	-1.94731405	-0.128737542	-0.129598662	0.125	LP9
U (LPi)	-0.052074061	-2.629820542	-0.097079323	-0.097467511	0.021105952	
λ (LPi)	-0.219072165	-2.139008621	-0.219072165	-0.220588235	0	LP8
U (LPi)	-0.084028459	-2.938332617	-0.125919118	-0.126477105	0	

Appendix D

Calculation Results for System Reliability Indices of Five Distribution System

In this appendix section D, the calculation results of system reliability indices of five distribution system (SAIFI, SAIDI, CAIDI and AENS) are described. The calculation works are done by using Microsoft Excel software and attached together with this thesis.

Table D.1: Calculation Results of System Reliability Indice (SAIFI)

SAIFI (interruptions/customer.yr)					
	Basic radial system	Link arrangement system	Open loop system	Close loop system	Primary network system
A	0.330720833	0.276045833	0.330720833	0.328720833	0.197583333
B	0.327120833	0.272445833	0.327120833	0.325120833	0.197583333
C	0.284830833	0.230155833	0.284830833	0.282830833	0.197583333
D	0.287490833	0.232815833	0.287490833	0.285490833	0.197583333
E	0.299220833	0.244545833	0.299220833	0.297220833	0.197583333

Table D.2: Calculation Results of System Reliability Indice (SAIDI)

SAIDI (minutes/customer)					
	Basic radial system	Link arrangement system	Open loop system	Close loop system	Primary network system
A	56.61925	28.33875	31.61925	31.49925	23.035
B	56.34925	28.06875	31.34925	31.22925	23.035
C	53.64925	25.36875	28.64925	28.52925	23.035
D	53.78925	25.50875	28.78925	28.66925	23.035
E	54.50925	26.22875	29.50925	29.38925	23.035

Table D.3: Calculation Results of System Reliability Indices (CAIDI)

CAIDI (minutes/customer interruption)					
	Basic radial system	Link arrangement system	Open loop system	Close loop system	Primary network system
A	171.1995263	102.6595825	95.60707041	95.8237106	116.5837199
B	172.2582124	103.0250661	95.83385344	96.05428751	116.5837199
C	188.3547837	110.2242321	100.5833872	100.8703672	116.5837199
D	187.099009	109.5662165	100.1397146	100.4209125	116.5837199
E	182.1706376	107.2549454	98.62030552	98.88018168	116.5837199

Table D.4: Calculation Results of System Reliability Indices (AENS)

AENS (kWh/customer)					
	Basic radial system	Link arrangement system	Open loop system	Close loop system	Primary network system
A	66337.45833	33170.20833	36997.45833	36857.45833	26982.5
B	66022.45833	32855.20833	36682.45833	36542.45833	26982.5
C	62872.45833	29705.20833	33532.45833	33392.45833	26982.5
D	63035.79167	29868.54167	33695.79167	33555.79167	26982.5
E	63875.79167	30708.54167	34535.79167	34395.79167	26982.5