



**NTNU – Trondheim**  
Norwegian University of  
Science and Technology

# Elemental Composition in various Marine Brown, Green and Red Macroalgae with respect to Season and Tissue-Age

**Wanda Kleiven**

Marine Coastal Development

Submission date: May 2014

Supervisor: Geir Johnsen, IBI

Co-supervisor: Murat Van Ardelan, IKJ

Norwegian University of Science and Technology  
Department of Biology



## ACKNOWLEDGMENTS

This thesis was carried out at Trondheim Biological Station (TBS), Norwegian University of Science and Technology (NTNU), Department of Biology from August 2012 until May 2014. It was part of a comprehensive macro algae project carried out by four students focusing on different aspects of macro-algal chemistry, physiology, taxonomy and ecology in Trondheimsfjorden. First I would like to thank my enthusiastic supervisor Geir Johnsen for his help and support during this two year period. Thanks for always being available for late night calls and making time for meetings and editing on your very busy schedule. I would also like to thank my co-supervisor Murat Van Ardelan for his help in improving my thesis and giving me insight to the chemistry world in form of interesting conversations and papers including help with laboratory work. Great thanks also go to Syverin Liangen for his help regarding the practical laboratory work and running the HR-ICP-MS. A lot of thanks to the “statistical guru” Jarle Mork for introducing me to Stat Graphics and giving me great statistical advice and moral support. I would also like to thank Inga Aamot for her advice and always keeping her office door open as well as taking the time to give me feedback on my work.

Special thanks go to my fellow macro algae students (Ane C. Kvernvik, Charlotte Hallerud and Lene Lund) at TBS for providing a great and fun work environment and for always being available to help with practical work, information and moral support in great need. I wish you all good luck with your own thesis. Also a special thanks to Niko Ristola for proof reading my final draft.

Also thanks to the rest of the students and staff at TBS for making my study period a memorable and fun experience, you are the best.

Trondheim, May 2014

Wanda Kleiven

**Front page:** *Laminaria digitata*, *Saccharina latissima*, *Ulva lactuca*, *Vertebrata lanosa*, *Ascophyllum nodosum*, *Fucus vesiculosus*, *Fucus spiralis* and *Fucus serratus* (Lund 2014).

## ABSTRACT

Macro algae are important for the ecosystem as they provide food and shelter for many organisms. Trace metal or Rare Earth Elements (REE) content of macro algae are very little understood and there is a great need for further understanding since macro algae may be used as important bio indicators. This thesis, by using High Resolution Inductive Coupled Plasma Spectrometer (HR-ICP-MS), investigates the trace metal and REE concentration and composition in the youngest tissue of various species within three algae classes (Phaeo-, Chloro- and Rhodophytes) in two seasons with the main focus on Phaeophytes (brown algae). It also investigates the element concentration in the kelp *Saccharina latissima* with respect to age of the algal tissue. Algal samples from February and May 2013 in Brønnebukta, Trondheim, Norway were found in a clear zonation depth order. A Clean-Lab (Class 1000) and plastic equipment were used to avoid contamination from e.g. metals. A significant difference in element concentration and composition was found between the Phaeophyte species along with a significant seasonal difference. A zonation depth trend in algal tissue element concentration was also found for the Phaeophytes where the algal species located in both extreme ends (shallowest and deepest growing) obtained a lower element concentration than the algae located in the middle of the zonation depth. This trend seems to result from the different contact with the metal rich Sea Surface Microlayer (SML). Due to its high concentrations of sugars, *Ascophyllum nodosum* deviated from this zonation depth trend for some elements with a lower element concentration than its neighboring species. There was a significant difference between the different parts of *S. latissima* (four tissue of different age) where most measured elements showed an exponential increase with respect to tissue age due to accumulation over time whereas the cadmium concentration, as the only exception, showed an exponential decrease with respect to tissue age possibly due to the need of cadmium for high photosynthetic rate. A great difference in element concentration and composition was found between the Phaeo-, Chloro- and Rhodophytes. The Chlorophytes had 5-27 times higher concentration of REE and lead (Pb) than the two other algal classes. Results indicate that the Rhodo- and Chlorophytes are better accumulators than the Phaeophytes for several trace metals and REE.

Key words: Macro-algae, zonation, REE, trace metals, concentration, tissue age

---

# TABLE OF CONTENTS

<b>1. Introduction.....</b>	<b>1</b>
1.1. Emission history of marine elements in Trondheimsfjorden.....	2
1.2. Macroalgae in Trondheimsfjorden .....	3
1.3. Bioavailability of elements .....	7
1.4. Rare Earth Elements (REE).....	9
1.5. Bioactive trace metals.....	10
1.6. Toxic trace metal .....	13
1.7. Aims of this study.....	13
<b>2. Material and Methods .....</b>	<b>14</b>
2.1. Experimental species and sample collection .....	14
2.2. Study location .....	15
2.3. Sample preparation .....	15
2.4. Decomposition and dilution of algal tissue .....	18
2.5. High-Resolution Inductive Coupled Plasma Mass Spectrometry (HR-ICP-MS) .....	19
2.6. Data analysis.....	21
<b>3. Results .....</b>	<b>23</b>
3.1. Phaeophyte and seasonal differences in element concentration and composition .....	23
3.2. Variation in the dataset.....	35
3.3. Differences in elemental composition between Phaeo-, Rhodo- and Chlorophytes .....	36
3.4. [Element] differences in <i>Saccharina latissima</i> with respect to tissue age .....	37
<b>4. Discussion.....</b>	<b>40</b>
4.1. Zonation depth trend.....	40
4.2. Environmental factors.....	41
4.3. Biological factors.....	42
4.4. Seasonal differences in elemental composition and concentration .....	44
4.5. Establishing basis levels of [element] in algal tissue .....	45

---

4.6. Differences in element composition and concentration between Phaeo-, Rhodo- and Chlorophytes.....	45
4.7. Element concentration differences in <i>saccharina latissima</i> with respect to tissue age....	46
4.8. For future studies .....	48
<b>5. Conclusion.....</b>	<b>49</b>
<b>6. References .....</b>	<b>51</b>

## APPENDICES

<b>Appendix 1.</b> Multifactorial ANOVA and LSD tables .....	<b>58</b>
<b>Appendix 2.</b> Multifactorial ANOVA and LSD tables for <i>Saccharina latissima</i> ..	<b>64</b>
<b>Appendix 3.</b> Ultra Clave report .....	<b>69</b>
<b>Appendix 4.</b> Figures of [element] with individuals separated .....	<b>70</b>
<b>Appendix 5.</b> Variance estimates .....	<b>92</b>
<b>Appendix 6.</b> Relative standard deviations for HR-ICP-MS.....	<b>96</b>

# 1. INTRODUCTION

Marine macro algae can be found all over the world and are very important for the ecosystem. They provide shelter and hatching grounds for other organisms and are also a crucial food source for others (Pedersen et al. 2012). Macro algae are also valuable for humans as they contain for example alginate and minerals for soil fertilization and animal nutrition. In fact, marine algae (including seafood) are known to be one of the richest sources of minerals (Karthikaidevi et al. 2010). There are however few studies regarding the qualitative and quantitative information of the elements in macro algae and what role they play in the different species (Karez et al 1994, Hamdy 2000). In recent years there has been an increase of the trace metal flux from both the atmosphere and from land runoff and therefore it is more important to understand the role of trace metals in aquatic systems (Førstner 1982). Biomonitoring of marine ecosystems is important for future environmental assessments, hence it is important to develop good bioindicators that can show the general health of the ecosystem. Kelp are shown to be good bioindicators as they are primary producers that are eaten by higher trophic levels and they grow in the littoral zone and can be harvested without the use of divers or expensive equipment (Carignan & Villard 2002, Burger et al. 2007).

Macro algae do not have any specialized root system to absorb ions and nutrients. In contrast to higher plants, algae obtain ions and nutrient directly through the lamina (Rueness 1977). Macro algae can accumulate higher concentrations of metals than the concentration in the water surrounding them, due to both passive and active absorption (transport of elements into the algal cell) (Ragan et al. 1979). How much and what kind of elements have been accumulated by different macro alga is still not clear as the studies on this subject conduct different elements in different species with different methods. Studies show that some macro algae species can accumulate more trace metals than others, and they might therefore be suitable for cleaning processes regarding an emission or for cleaning wastewater (Holan et al 1993; Lee and Chang 2011).

There is a need for more research regarding macro algae and the different elements' role in algal tissue as there is minimal information about this subject as of today. A basis level of trace metals and REE within macro algal tissue has not yet been estimated in Trondheimsfjorden. It is important to do so due to the increasing demand for information on the environmental condition and also the lack of knowledge regarding this matter. There are

also few studies conducting trace metals without iron contamination as iron equipment are often used. This contamination can be eliminated by using a clean lab (Martin 1990) used in this study as described in Material and Methods. In most kelp studies in the past, the kelp has been homogenized and analyzed as a whole where age and the different parts of the algae have not been studied separately (Burger et al. 2007).

To be able to manage the environment and develop a sustainable exploitation of Trondheimsfjorden, there is a great need for further studies on macro algae and especially with respect to element composition and concentration both in macro algae and in the surrounding seawater. It is also important to develop a wider understanding of the biological, physiological and chemical interactions that shape and control the macro algal community and all the species and resources that depend on it.

## 1.1. EMISSION HISTORY OF MARINE ELEMENTS IN TRONDHEIMSFJORDEN

Trondheimsfjorden is an open fjord with direct connection to the Norwegian Sea. The fjord is 126km long with a volume of 235km<sup>3</sup> and has three sills which divide the fjord into three “basins” but these are still not inhibiting the circulation and water exchange in the fjord (Bakken 2000). The mineral metal industry has been a big resource in Trondheim for many years but this is today no longer in progress. From the 1970’s people started to be more concerned about the environment and also for heavy metal emissions, hence some studies of metal concentrations in the fjord were undertaken (Jensen et al. 2000). From studies on macro algae Jensen et al. (2000) found that there are some basis levels of metal in the algae tissue which, if measured in the right area, could be used as a reference of pollution. Some studies were done in 1973 on *Ascophyllum nodosum* (*A. nodosum*) ((L.) Le Jolis 1863) in Lofoten, Norway where the basis level in dry algal tissue was thought to be 75µg Zn/g dry tissue, 5.5µg Cu/g dry tissue, less than 3µg Pb/g dry tissue and less than 0.7µg Cd/g dry tissue. The concentrations in *A. nodosum* in Trolla (Bænnebukta, Trondheimsfjorden) were, however, a great deal higher for Zn (375-700µg/g) and Cu (18-60µg/g), and also high for Zn (120µg/g) in the outer parts of the fjord in 1973 (Jensen et al. 2000). In 1987 another study was undertaken near Brænnebukta, revealing [Cu] in *A. nodosum* as the only elevated metal indicating that previous pollution is now disappearing and an estimation of the basis concentration levels might be possible today (Jensen et al. 2000). Other pollutants to the fjord in form of land-



emission by rivers, aircraft, shipping and other small industries still occur, but Trondheimsfjorden is today considered relatively clean (Oceanor 2003).

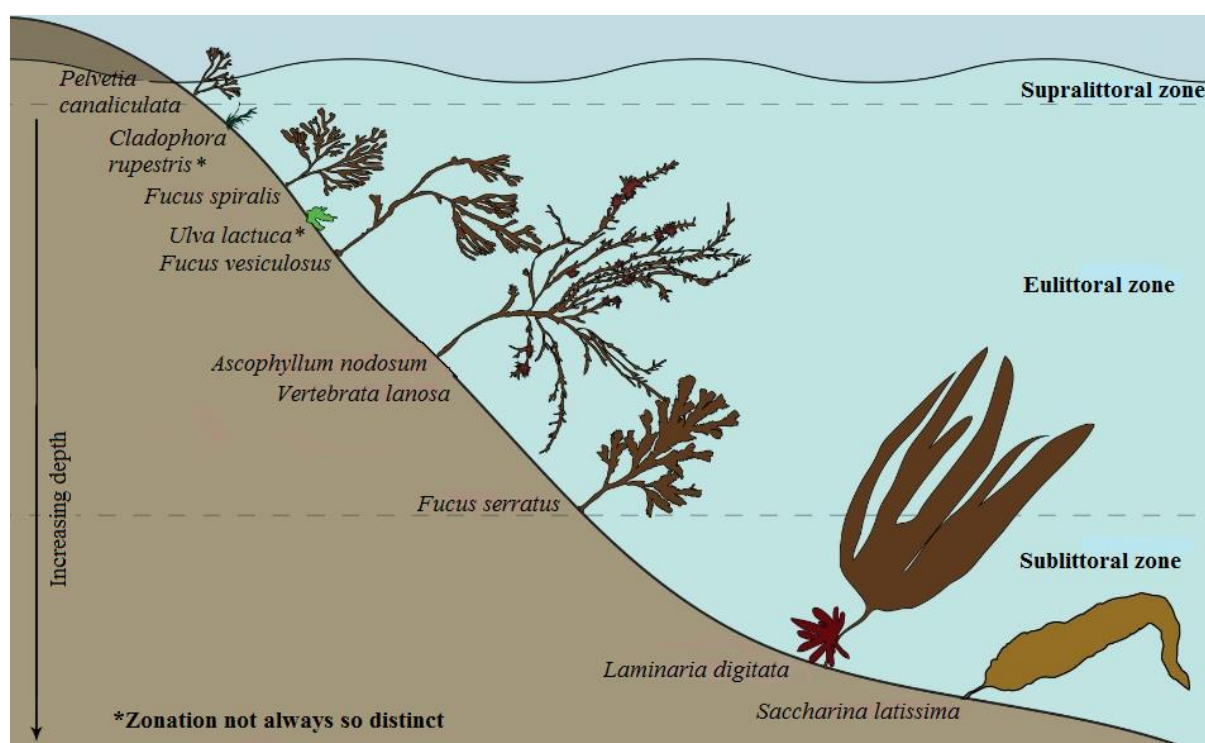
## 1.2. MACROALGAE IN TRONDHEIMSFJORDEN

Macro algae can vary greatly in shape and size and are defined as benthic multicellular photosynthetic organisms. Macro algae are divided into Phaeophytes (brown algae), Rhodophytes (red algae) and Chlorophytes (green algae). The Phaeophytes provide the highest macro algal biomass in Norwegian waters whereas Rhodophytes are most species diverse (Rueness 1977). Most macro algae in the sub-arctic or temperate areas of the northern hemisphere have the most rapid growth from January till May (Andersen et al. 2011; Rueness 1977) and an intermediate growth rate from June till December (Mathieson et al. 1976). Macro algae store nutrients in their tissue from the rich winter water to compensate for the phytoplankton spring bloom which depletes the surface waters of nutrients (Sjøtun 1995). In early summer (June) and during autumn there is a lot of epigrowth, which consists of different organisms that grow directly on the algae and can lead to less light availability and damaging of the algal tissue. Some organisms can however also protect the algae from damaging light and produce nutrients like nitrogen that the algae can absorb (Sand-Jensen 1977; Saunders and Metaxas 2007).

Kelp, the big Laminarian Phaeophytes, have their cell division in the base of the meristem (see Figure 5 in section 2.3.1.) in contrast to the rest of the Phaeophytes, Chlorophytes and Rhodophytes that have their cell division in the tip of each lamina (“branch”), hence the youngest tissue can be found in these parts of the plant (Seed and Harris 1980). Kelp also contain a lot of alginate (amongst many other sugars), which is the main supportive tissue to withstand currents and wave action (Martone 2007). The Fuciods (Phaeophytes) have generally less of the different sugars than kelp, but still there are differences between Fuciod species where some have more than others (Percival and McDowell 1967). Kelp produces mucilage layers consisting of polysaccharides, often in response to mechanical stress, which is a slimy substance mainly consisting of the sugar mannitol (Salaün et al. 2012). This also functions as a protective boundary layer for air exposure, wave and current action and epiphytes (Salaün et al. 2012).

According to Valle (2005) there are great differences within and amongst the algal tissue cell structure and a clear depth zonation in Trondheimsfjorden (see Figure 1) (Rueness 1977). The

tide in Trondheimsfjorden has a mean range of 1.8m, leaving the shallowest growing algae (*Pelvetia canaliculata* (*P. canaliculata*) ((L.) Decaisne, & Thuret 1845) with the longest time exposed to air and *Saccharina latissima* (*S. latissima*) ((L.) C.E.Lane, C.Mayers, Druehl and G.W.Saunders 2006) the shortest (Valle 2005; Web page #3). In addition to the tide, macro algae in the tidal zone are exposed to water movements differently depending on where they are located on the globe, bottom substrate (grain size of sediments and rocks) and the exposure to physical factors such as waves, wind and current speed and direction. The most important factor when it comes to shaping the macro algal community is the water movements and light regime (also affected by sedimentation) (Rueness 1977; Andersen et al. 2011).



**Figure 1.** Depth zonation of the experimental species and the corresponding littoral zones (depth profile). The Supralittoral zone (the very top of the depth zonation where the algae are mostly moistened by wave splashing), Eulittoral zone (the middle part where most species can be found) and the Sublittoral zone (starts where the tide is at its lowest and ends when there is no vegetation) are also shown on the right. The size of the Eulittoral zone depends on the tide in the area (Rueness 1977) (Figure: Hallerud 2014, Kleiven 2014 (ed.)).

The species shown in Figure 1 are also described in more detail below as these were also the experimental species in this thesis.

### 1.2.1. PHAEOPHYTA (BROWN ALGAE)

#### *Pelvetia canaliculata* (Channeled Wrack) (L.) Decaisne, & Thuret 1845

The thallus is usually 2-15 cm in length and has round branch tips. *Pelvetia canaliculata* (*P.canaliculata*, Furoid) is one of the macro algae that grow high in the littoral zone (supralittoral zone) and it is exposed to drought for long periods during the day (Rueness 1977). This species can be found on the west coast of Northern Europe and can reach an age of 4 or 5 years (Lüning 1990).

#### *Fucus spiralis* (Spiral wrack) (L. 1753)

*Fucus spiralis* (*F. spiralis*, Furoid) is usually 5-39 cm tall with spiral twisted branches and a distinct middle rib. It is mostly found in unexposed (low tide) parts of the upper littoral zone on the coast of Canada, Iceland and Europe and can be 2-5 years old (Rueness, 1977; Lüning 1990).

#### *Fucus vesiculosus* (Bladder wrack) (L. 1753)

This alga is known for its various shapes and sizes. It is usually recognized by its pairwise bladders on both sides of a middle rib (Rueness 1977). *Fucus vesiculosus* (*F. vesiculosus*, Furoid) is very common along the shoreline of Europe, South Greenland, Iceland and Canada and can become 5 years old (Lüning 1990) in the eulittoral zone (Rueness 1977).

#### *Ascophyllum nodosum* (Knotted wrack) (L.) Le Jolis 1863

Thallus of *Ascophyllum* (*A. nodosum*, Furoid) can grow up to 2 m in length but is usually 0.3-1 m. It has a distinct middle rib with single bladders on the blade (Rueness 1977). *A. nodosum* can be 15 years old and it is a very common alga on the shoreline of Europe, Iceland, Canada and South Greenland (Lüning 1990). Together with *F. vesiculosus* this alga constitutes most of the algal biomass in the littoral zone (Rueness 1977).

#### *Fucus serratus* (Toothed wrack) (L. 1753)

This species can be 30-60 cm long and is commonly recognized by its distinct middle rib and the serrated edge of the lamina. It is located in the middle part of the littoral zone and can grow on both exposed and un-exposed sites (Rueness 1977). *Fucus serratus* (*F. serratus*, Furoid) can be found along the western side of the North Atlantic and get to be several years old (Lüning 1990).

*Laminaria digitata* (Oarweed) (Hudson) J.V. Lamouroux 1813

This alga, with a smooth and bendable stipe, can grow to be as tall as 2-3 m and 10 years old. Lamina is thin and broad in un-exposed locations and thicker and narrower in exposed locations (Rueness 1977). *Laminaria digitata* (*L. digitata*, Laminarean) is found on the coastline of the North Atlantic and Barents Sea (Lüning 1990). Note that *L. digitata* is in fact a species complex that may comprise *L. digitata*, *Lamiaria hyperborea* and *Saccharina groenlandicaa*. (Lund 2014).

*Saccharina latissima* (Sugar kelp) (L.) C.E.Lane, C.Mayers, Druehl & G.W.Saunders 2006

The lamina of *Saccharina latissima* (*S. latissima*, Laminarean) is usually between 1 and 3 m with an additional 5-30 cm long stipe. The lamina is dimpled along the middle all the way to the tip and the edges are frayed. *S. latissima* can be found in the deeper part of the littoral zone (Rueness 1977) along the shoreline of almost the whole Northern Hemisphere and usually reaches an age of 2-5 years (Lüning 1990).

## 1.2.2. RHODOPHYTA (RED ALGAE)

*Vertebrata lanosa* (L.) T.A. Christensen 1967

*Vertebrata lanosa* (*V. lanosa*) are 2-7 cm small tuft-like algae growing for several years on *A. nodosum* and occasionally on other brown algae (usually on *Fucus* spp.). This alga is considered both an autotroph and a parasite, although it does not kill its host (Lüning 1990).

## 1.2.3. CHLOROPHYTA (GREEN ALGAE)

*Ulva lactuca* (L. 1753)

*Ulva lactuca* (*U. lactuca*), an annual opportunist (Rueness 1998), is one of the dominating green algae in Scandinavia. It is found in the littoral zone and down to 15 m almost all over the world. Thallus is round and thin (two cell layers thick) and it can become 1m tall and have a diameter of 20 cm (Lüning 1990).

*Cladophora rupestris* (L.) Kützing 1843

This alga has a tuft-like structure with thick cell walls and is usually around 10 cm in height. *Cladophora rupestris* (*C. rupestris*) is common all over Europe's shoreline and can grow down to 20 m depth (Lüning 1990). This species is usually found in the eulittoral zone but and can also exist in the supralittoral zone (Rueness 1998).

### 1.3. BIOAVAILABILITY OF ELEMENTS

It is assumed that Phaeophytes cannot regulate the uptake of trace metals and accumulation is therefore mainly influenced by the total amount of trace metal in the water surrounding the organism and the metals bioavailability (Gutknecht 1965; Bryan 1969). Bioavailability and biological significance of trace metals in aquatic systems are important to determine for a better understanding of the metal accumulation throughout the food chain and the trace metals' toxicity in different organisms. Macro algae can in theory accumulate and absorb particulate and dissolved trace metals, either from the water surrounding them or from the sediments (Wheeler 1980). How and how much of the different trace metals they accumulate and absorb, depend on a variety of chemical, physiological and biological factors which are yet poorly understood. Ions can be absorbed by the algal cell by moving across the boundary layer of the alga (Wheeler 1980). A boundary layer is a viscous layer around an aquatic organism where the flow is parallel to the surface of the object and it creates resistance for element uptake. The flux or diffusion of ions passing through this layer is dependent on the thickness of the layer where a thick layer can result in a slower ion uptake. The thickness can vary greatly depending on a variety of physical factors (Wheeler 1980).

There are a lot of trace metals bound in the sediments in inorganic, organic and particular matter. Mobile sediments may be an important source of metals for macro algae as these are more available for absorption and accumulation (Tessier and Campbell 1987). Waves, storms and tides can create mobile sediments (suspended and re-suspended matter) as they stir the water and also stir the shallow enough sediments (Eisma 1981). Suspended matter consists of particles from dead plankton, dust from atmosphere and river run-off that hasn't yet settled on the seafloor (Eisma 1981).

The accumulation of trace metals is dependent on the amount of trace metal in the water and their time response, where too much of a certain element can become toxic to various organisms (Tessier and Campbell 1987).

### 1.3.1. SEA SURFACE MICRO LAYER (SML)

The sea surface micro layer (SML) is a ~50 $\mu$ m thick viscous boundary layer in the surface of the ocean (Hardy 1982). This layer has a unique physical, chemical and biological property and it is believed that some of the metals are also available for various marine organisms, although most of the elements are associated with particles (Hardy and Creelius 1981). In the SML there can be between 10 to 1000 times higher concentrations of trace metals than the sea water just a few cm below it, and trace metals from the atmosphere move more slowly through this viscous SML. The SML covers about 70% of earth's surface and may play a significant role in elemental cycling in the ocean (Hunter 1997).

**Periodic Table of the Elements**

1 H																	2 He	
3 Li	4 Be											5 B	6 C	7 N	8 O	9 F	10 Ne	
11 Na	12 Mg											13 Al	14 Si	15 P	16 S	17 Cl	18 Ar	
19 K	20 Ca	21 Sc	22 Ti	23 V	24 Cr	25 Mn	26 Fe	27 Co	28 Ni	29 Cu	30 Zn	31 Ga	32 Ge	33 As	34 Se	35 Br	36 Kr	
37 Rb	38 Sr	39 Y	40 Zr	41 Nb	42 Mo	43 Tc	44 Ru	45 Rh	46 Pd	47 Ag	48 Cd	49 In	50 Sn	51 Sb	52 Te	53 I	54 Xe	
55 Cs	56 Ba	57 La	72 Hf	73 Ta	74 W	75 Re	76 Os	77 Ir	78 Pt	79 Au	80 Hg	81 Tl	82 Pb	83 Bi	84 Po	85 At	86 Rn	
87 Fr	88 Ra	89 Ac	104 Unq	105 Unp	106 Unh	107 Uns	108 Uno	109 Une	110 Unn									
			51 Ce	59 Pr	60 Nd	61 Pm	62 Sm	63 Eu	64 Gd	65 Tb	66 Dy	67 Ho	68 Er	69 Tm	70 Yb	71 Lu		
			90 Th	91 Pa	92 U	93 Np	94 Pu	95 Am	96 Cm	97 Bk	98 Cf	99 Es	100 Fm	101 Md	102 No	103 Lr		

**Figure 2.** A picture of the periodic table of elements with the elements grouped in Hydrogen, alkali metals, alkali earth metals, transition metals (trace metals), poor metals, non-metals, noble gases and rare earth elements. The rare earth metals can be divided into the “light” rare earth elements (REE) (Lanthanides, atom numbers 57-71, 21 and 39), and the “heavy” radioactive rare earth elements (atom numbers 90-103). The elements used in this thesis are boxed in green (bioactive trace metals), red (toxic element) and yellow (rare earth elements) (Web site #1).

## 1.4. RARE EARTH ELEMENTS (REE)

The rare earth elements (REE) are the 15 lanthanides (lanthanum (La), cerium (Ce), praseodymium (Pr), neodymium (Nd), promethium (Pm), samarium (Sm), europium (Eu), gadolinium (Gd), terbium (Tb), dysprosium (Dy), holmium (Ho), erbium (Er), thulium (Tm), ytterbium (Yb) and lutetium (Lu)), together with yttrium (Y) and scandium (Sc) (see Figure 2) where Pm is the most rare and Ce is the most abundant (Web site #1). The REE have a different chemistry than other bioactive and toxic elements, and they are therefore often used as tracers for different biological processes (Castor and Hedrick 2006). Even though the name indicates that the REE are very rare, they are more common than silver and mercury (except Promethium) and the earth's crust contains more REE than copper and lead (Castor and Hedrick 2006). It is believed that the REE play no biological role in the algal cell but they may interact with biological material, like the isomorphic replacement of Calcium ( $\text{Ca}^{2+}$ ) (Evans 1983; Panagiotopoulos et al. 2010). De Baar (1983) suggests that rivers are an important source of REE into the ocean. The REE used in this thesis are described below in more detail.

### 1.4.1. CERIUM (Ce)

Cerium (Ce), with the atom number 58, is the most common of all the REE (Elementdatabase.com). It is usually found in the earth crust and is commercially used as a catalyst in cars etc. to limit carbon dioxide emissions. Ce is also used in glass polishing powders to make special types of glass (Web site #1).

### 1.4.2. TERBIUM (Tb)

Terbium (Tb) was isolated recently (Web site #1) and little is therefore known about it. Tb has the atom number 65 and is a soft silver colored metal. There are no commercial uses of Tb yet (Web site #1).

### 1.4.3. YTTERBIUM (Yb)

Ytterbium (Yb) was isolated first in the 1950's and has the atom number 70. Little is known about this REE other than that it is a silver colored and soft metal (Web site #1).

## 1.5. BIOACTIVE TRACE METALS

Bioactive trace metals play one or several roles in the eukaryote and prokaryote cell and are significant for the plant cell. The concentration of trace metals is defined as concentrations  $<0.01\mu\text{g/g}$  in seawater (Morel and Price 2003). Bioactive trace metals are not needed in large amounts like magnesium and sodium, but they are still important for several functions and thus survival of the organism. The amount necessary for survival depends on the species and some bioactive trace metals can be toxic in certain amounts, also depending on the metal and the species (Frausto da Silva and Williams 2001). The bioactive trace metals in this thesis are described in more detail below.

### 1.5.1. IRON (Fe)

Iron's (Fe) role in organisms and their speciation in seawater is very complex but also very important (Frausto da Silva and Williams 2001). Fe plays a crucial role in plant metabolism as it is needed in photosynthesis, chlorophyll synthesis and nitrate reduction (Sunda and Huntsman 1995). It is also known to control the phytoplankton biomass in the ocean and is often a limiting growth factor in the open ocean and especially in the Southern Ocean (Croot et al. 2001). Fe is very redox active and exists as free ions in seawater, mostly as Fe(III) in oxygen rich water and Fe(II) in anoxic water. The main source of Fe to the surface ocean is dust depositions which originate mostly from desert areas (Prospero et al. 2002). Other sources of iron to the ocean can be hydrothermal vents, artificial Fe fertilization or emission and natural marine processes (Breitbarth et al. 2010).

### 1.5.2. NICKEL (Ni)

Studies of nickel (Ni) in marine algae cells are rare, and it is still not proven useful in plants and thought to be poisonous in big amounts, although it does take place in some biological reactions (Holan and Volesky 1994). Ni has a similar structure to manganese, which can result in inhibition of manganese reactions as Ni could replace manganese (Frausto da Silva and Williams 2001). There have also been observations of Ni in the enzyme urease in plants (Frausto da Silva and Williams 2001). Even though the role of Ni is little understood, it can be concluded that Ni is mostly unwanted by organisms due to a slow exchange rate (Frausto da Silva and Williams 2001). Ni is not known to accumulate in the plant cell or further up the food chain (Web site #1)



### 1.5.3. COPPER (Cu)

Copper (Cu) has played an important biological role since the atmosphere and Fe became oxygenized (from Fe(II) to Fe(III)). Cu could no longer bind easily to Fe, forming Fe-Cu compounds, hence Cu became more soluble (Professor Ardelan MV, pers com 05.2014, Department of Chemistry, NTNU). Copper has many functions in plant and algal cells as it is required for electron transport, participates in various enzymes and might also function as a receptor for the major plant hormone ethylene (Manahan 2010). Cu is considered a low-toxicity element and is nowadays commonly used as marine antifouling agents (avoiding biofilm and epigrowth). The toxicity of Cu is mainly due to its competitive inhibition of other metal-requiring systems in the cell (Brand et al. 1986). Cu input to the ocean is mainly natural and can be introduced from rock and soil erosion, organic matter, volcanoes and hydrothermal vents (Blossom 2007).

### 1.5.4. ZINC (Zn)

Zinc (Zn) is the most common trace metal ion in the cytoplasm of aerobic cell organisms (Frausto da Silva and Williams 2001). It is also the most common trace metal in seawater (Frausto da Silva and Williams 2001) and is considered essential in algal cells, especially in proteins that control DNA expressions (Xu et al. 2012). It is used as a co-factor in many enzymes in the algal cell (Xu et al. 2012). Zn is not particularly toxic in animal cells but can be very toxic in algal cells in high amounts (Manahan 2010).

### 1.5.5. MANGANESE (Mn)

Manganese (Mn) is thought to be very important for plant survival but there are not many studies conducting this yet. The biggest known role of Mn is as an oxygen releaser in photosystem II and it is also involved in many enzymes and other proteins (Farusto da Silva and Williams 2001). Mn is transported to the ocean from the air, land erosion and hydrothermal vents (Landing and Bruland 1987). Mn is very redox active, and exists in oxygen rich seawater usually as the ion Mn(IV) (Farusto da Silva and Williams 2001). The average abundance of Mn in the ocean is 0.03 $\mu$ g/kg but the local concentration can vary a lot depending on the geography (Bruland 1983).

### 1.5.6. COBALT (Co)

Cobalt (Co) is not considered important for algae functionality and it is a relatively rare element. There are a few processes that take place in the cytoplasm of many organisms (e.g. vitamin B12) that involve Co, but usually Co can be replaced by Zn which is a more abundant element. It is thought that enzymes containing Co are remnants from earlier time when Zn was not as abundant (Frausto da Silva & Williams 2001).

### 1.5.7. CADMIUM (Cd)

Cadmium (Cd) is known to be very toxic and exposure to Cd can lead to nerve damage and renal failure in humans (Bertin and Averbeck 2006). Cd is used in e.g. electronic industries and it also accumulates through the food chain (Holan et al. 1993). Some studies show that Cd can be used as a nutrient in some marine microalgae instead of zinc and that some bacteria can develop a tolerance against Cd (Morel 1995). Uptake of Cd in other organisms has been documented, but its significance and role are still not well understood (Holan et al. 1993). Cd is considered toxic for plants, algae and animals, although it is believed that Cd plays a role (as well as Zn and Co), in carbon assimilation (Markham et al. 1980). Macro algae are also known to accumulate Cd, and the concentration in the algal tissue can be greater than the surrounding water, which is on average less than 0.1 µg/kg in seawater (Markham et al. 1980).

## 1.6. TOXIC TRACE METAL

Toxicity of an element is species and specimen dependent, as the bioavailability, concentration and duration of exposure varies (Tessier and Campbell 1987). The toxic trace metal in this thesis is described in more detail below.

### 1.6.1. LEAD (Pb)

Lead (Pb) is considered a toxic trace metal but it is still used in industries around the world (Manahan 2010). The main source of Pb in the atmosphere and thus in water is gasoline-containing Pb, although since 1980, lead-free gasoline is more commonly used. Coal burning also results in airborne Pb, but this is only a fraction of the Pb already present from earlier times (Dunlap et al. 1999). Pb binds easily to proteins and can therefore lead to enzymatic breakdown in many cases (Needleman 2004). Pb can also be dangerous for the human nervous system as it competes with calcium and it can also be a danger to an unborn child or the reproductive cycle (Markovac and Goldstein 1988). It is known that small amounts of Pb is accumulated in the environment and concentrated throughout the food chain. Pb is also found in various marine algae in several studies and does have a known toxic effect on their metabolism (Holan and Volesky 1994). Recent studies show that marine algae have passive absorption of many metals including Pb (Hamdy 2000).

## 1.7. AIMS OF THIS STUDY

The main goal of this thesis is to check whether the element composition and concentration in macro algae depends on species, season and age and if possible determine how they differ. The significance level of species differences was checked for the Phaeophytes as well as seasonal (February and May). The elemental concentration and composition with respect to age (time) in the algal tissue was tested on different parts of *S. latissima* in May. In addition to this, the differences in element composition and concentration between the Phaeophytes, Chlorophytes and Rhodophytes are shown and discussed.

## 2. MATERIALS AND METHODS

### 2.1. EXPERIMENTAL SPECIES AND SAMPLE COLLECTION

All macroalgal species used in this thesis are common in Norway and can all be found in the tidal zone (Rueness 1977). These species were chosen due to availability and their dominant status in the Norwegian littoral zone.

Ten species (*P. canaliculata*, *F. vesiculosus*, *F. spiralis*, *A. nodosum*, *F. serratus*, *S. latissima*, *L. digitata*, *C. rupestris*, *U. lactuca* and *V. lanosa*) were collected in total where eight were sampled during winter (February 28th) and spring (May 6th) 2013. *Ulva lactuca* was sampled only in February in the uppermost layer of the littoral zone and replaced by *C. rupestris* in May. The *C. rupestris* used in this study were also found in the uppermost layer of the littoral zone, close to *P. canaliculata*. The alga *V. lanosa* was taken from sampled *A. nodosum* individuals. Three individuals were sampled for each of the nine species, with the exception of *U. lactuca* with only two individuals found in winter and none in spring. Most of the individuals were collected by hand during low tide, except for *L. digitata* and *S. latissima* which were collected by snorkeling (2-5 m depth). All specimens were handled with clean plastic equipment and gloves to avoid skin and metal contamination and put in separate plastic bags marked with species names and numbers. All samples were taken directly to the laboratory (30 minutes) for further handling.

## 2.2. STUDY LOCATION

The field sampling was carried out in winter and spring of 2013 at Brønnebukta in Trondheimsfjorden, 63°26'52.44"N; 10°19'45.12"E (see Figure 3). There were two samplings in total, both in the tidal zone where the habitat was dominated by *L. digitata*. This site was chosen due to its clear algal zonation depth and low contamination of trace metal pollutants from both land and the seawater (Oceanor 2003). The tidal range in this period was about 180cm on May 6<sup>th</sup> with a water temperature around 4°C and 260 cm on February 28<sup>th</sup> with a water temperature around 12°C.

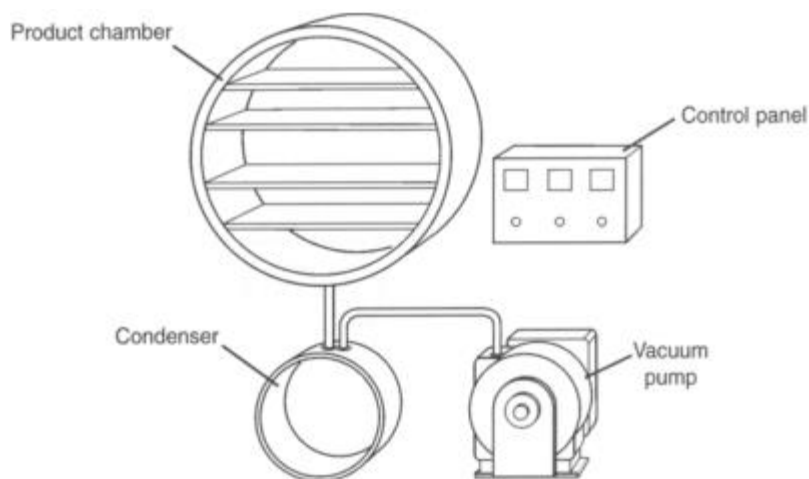


**Figure 3.** Map of Trondheim and Brønnebukta where the samples were collected (Web site #2).

## 2.3. SAMPLE PREPARATION

The samples were brought to a clean laboratory (class 1000), where there is a low and controlled level of pollutants, and washed thoroughly with MilliQ water (18.2. mΩ). All plastic materials used during sample treatment were acid washed with HCl (supra pure 2-3 M), and rinsed with MilliQ water. Three replicates of the youngest tissue from each individual were used except for the three individuals of *S. latissima* in the spring sampling. These were used in an age study described in paragraph 2.3.1. In addition to the use of the youngest tissue, it was stressed to avoid tissue with epi-growth.

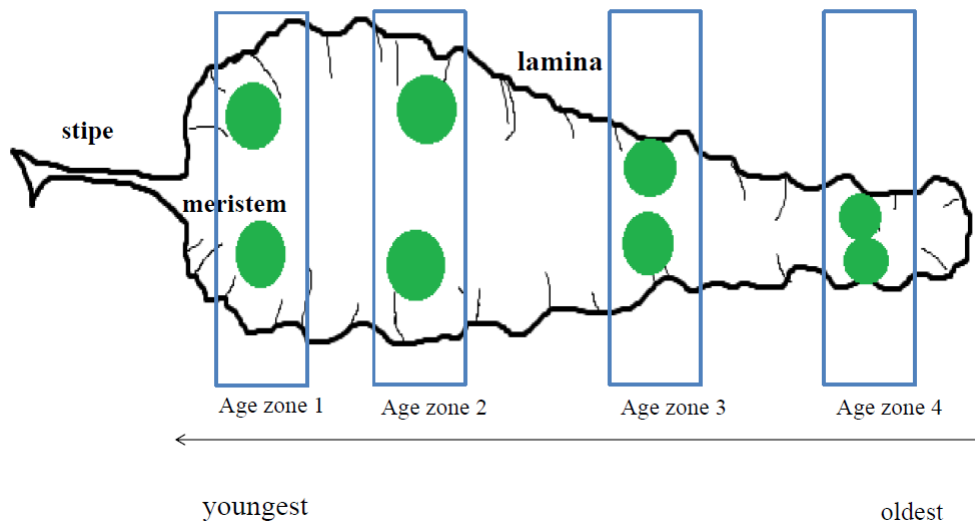
The algae tissue was cut out using a Teflon knife and board and placed in a plastic jar with plastic lids marked with numbers. Wet weight was measured and the samples were placed in a freezer. When the tissue samples were frozen solid, they were placed in a freeze dryer (Christ LDC-1, Vakumservice AS, Lørenskog, Norway) to remove all the water both outside and inside the cell walls. The plastic jars with the frozen algal tissue were placed on a shelf inside the freeze dryer and heat was applied to the shelf. This resulted in a sublimation of the frozen water and the water vapor was removed from the algal tissue and condensed on the condenser (see Figure 2) through the hole in the previously punctured lid. The vacuum pump removed air and water vapor from the system until the alga tissue was completely water free (Abdelwahed et al. 2006). After freeze-drying for approximately 24 hours under a pressure of 0,6ATM at -20°C the tissue samples were taken out and dry weight was measured.



**Figure 4.** An illustration of a typical freeze dryer with a product chamber with heating shelves, a condenser, control panel and a vacuum pump for removal of condensed water (Web page #4).

### 2.3.1. SAMPLE PREPARATION OF *SACCHARINA LATISSIMA*

Three individuals with the lamina-length of 130, 195 and 180 cm, measured from the meristem to the tip of the lamina, were used. Tissue samples were cut out as shown in Figure 5.



**Figure 5.** Lamina morphology of *S. latissima*. Green circles represent the tissue samples that were cut out for analysis. The age zones 1, 2, 3 and 4 with tissue samples in different “age boxes” where age zone 1 is the youngest and age zone 4 is the oldest (Kleiven 2014).

Two replicates for each age zone were taken from the three individuals, and four age zones were chosen for each individual. The lengths between the tissue samples were not measured, but they were evenly spread throughout the lamina, as Figure 5 shows, so that all age stages of *S. latissima* would be represented.

## 2.4. DECOMPOSITION AND DILUTION OF ALGAL TISSUE

The dry algae samples were placed in individual Teflon tubes, pre-washed with ultra-pure HNO<sub>3</sub> (7,8M) and rinsed with MilliQ water including the Teflon tubes that were used for the blanks and Polish Tobacco (a reference material with a known elemental composition). 6ml of ultra-pure nitric acid (HNO<sub>3</sub>, 7.8M) were added to each Teflon tube, including the blank and reference samples, and the samples were placed in UltraClave Microwave Autoclave (Ultra Clave, Milestone, Sorisole, Italy) for decomposition. UltraClave uses microwaves to decompose organic matter to ionic form in a single reaction chamber (Mosely et al. 2008). There were 173 algal tissue samples in total, and the Ultra Clave was in total run six times with up to 40 samples per sampling sequence. Three blank samples were used for every round of Ultra Clave resulting in a total of 18 blanks. Every third Ultra Clave sequence four Teflon tubes with Polish Tobacco were also run through the Ultra Clave.

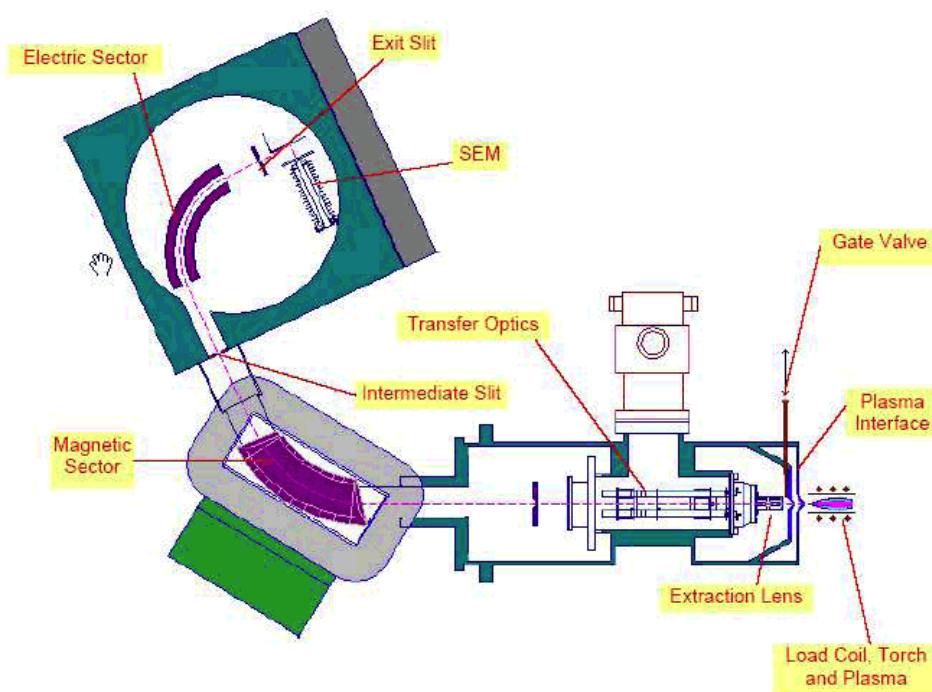
The samples were exposed to 245°C and a pressure of 195 bar for a thorough decomposition in an oxidative mixture of HNO<sub>3</sub> and hydrogen peroxide (H<sub>2</sub>O<sub>2</sub>) which were added to make sure that all organic material was broken down. The Teflon tubes containing algal tissue were placed in a water bath which absorbs the heat from the microwave unit (Mosely et al. 2008). A computer monitored the reaction temperature, HNO<sub>3</sub> pressure, reaction pressure and a procedure time of approximately 3 h (Appendix 3) After this, the samples became a homogenized, transparent solution.

The decomposed samples were diluted with MilliQ water to a total of 60mL or 61g (±0,3g) and placed in a trace metal clean plastic tube. This procedure was also used for the blank samples and reference material.



## 2.5. HIGH-RESOLUTION INDUCTIVE COUPLED PLASMA MASS SPECTROMETRY (HR-ICP-MS)

Thermo Electronics element 2-HR-ICP-MS (ELEMENT 2, Thermo Fisher Scientific, USA) was used in this study for elemental determination in macro algae. ICP-MS is a sequential analytical method for measuring ionic concentration in a solution, usually in aquatic form (Taylor 2001; Skoog 2013). This method is very precise as it can measure analytes down to 1 ng per liter and correct for interferences such as overlapping isotopes (Skoog 2013). A schematic picture of an ICP-MS machine is shown in Figure 6 below.



**Figure 6.** Illustration of a High Resolution Inductive Coupled Plasma Mass Spectrometry (HR-ICP-MS) system and its different components. The electric and magnetic sector combined makes this a High Resolution ICP-MS. The Load Coil is where the sample becomes in aerosol state and where they are collided with the inert argon gas to make ions. The extraction lens is electrostatic and therefore focuses the stream of ions as it moves on to the Transfer Optics section. This is where the quadruple mass filter is placed only allowing ions of a single mass to charge ratio pass through. SEM (Secondary Electron Multiplier) translates the electron beam into an electric signal (Web page #5).

### 2.5.1. PLASMA

Plasma is in this case an electrically neutral argon gas made of positive ions and free electrons. The argon gas is an inert gas not reacting with the target compounds. The plasma is highly energetic and obtains a high temperature and pressure to easily atomize and ionize the elements of interest. The proportion of elements in the original sample is equal to the proportion of ionized sample elements in the plasma (Taylor 2001). The algal tissue samples are first converted to aerosols, which in this study are small particles of liquid, and then transported to the plasma using an argon gas stream.

### 2.5.2. INTERFACE

In the interface, the initial kinetic energy of the ions is reduced before entering the Mass Spectrometer (MS) (see Figure 6). The ions are then led through a small orifice becoming a stream of ions and then through an even smaller orifice to concentrate the ions even further. Water cooled cones of metal, usually Nickel or Platinum, are used to cool down the ionized sample and a vacuum pump is used to lower the atmospheric pressure (Taylor 2001; Skoog, 2013). Before entering the mass spectrometer (MS), the ion beam meets a negatively charged metal plate called a photon stopper to remove neutral and positively charged species like photons or other charged particles. This is because these can scatter and increase the background signal hence making the analysis less precise (Taylor 2001).

### 2.5.3. MASS SPECTROMETER (MS)

As the ion beam enters the mass spectrometer the ions have the same velocity and therefore their kinetic energy is completely dependent on the ion mass. The ions then pass through a quadrupole magnetic field and are deflected at an angle proportional to their mass and charge which can then be picked up by a detector (Skoog et al. 2013; Web page #5). The detector determines the elements and their quantities, hence their mass-to-charge ratio (Taylor 2001). This instrument sends the ions through an electrostatic sector as well as a magnetic sector (see Figure 6) for extra sensitive results (Taylor 2001).

The ions have to be counted by a suitable detector which can translate the number of striking electrons into an electric signal for a computer to read (Skoog et al. 2013; Web page #). In this case a Secondary Electron Multiplier (SEM, see Figure 6) was used. SEM gives qualitative and quantitative information about the sample by scanning it with an energized electron beam (Skoog et al. 2013; Web page #5).

#### 2.5.4. ATOM INTERFERENCE

Atoms with the same mass to charge ratio can make spectroscopic interference. The newest models of ICP-MS machines can usually correct for all the known overlapping isotopes and isobaric interferences (May and Wiedemeyer 1998). Polyatomic interference, which is ions consisting of two or more atoms, is one of the biggest problems when it comes to interference in ICP-MS systems (Shvartsburg and Jarrod 1996). One example of polyatomic interference is  $^{75}\text{As}$  with atomic weight of 74.92160 and  $^{40}\text{Ar}^{35}\text{Cl}$  with almost exactly the same atomic weight of 74.93123 (Skoog et al. 2013; Web page #5). Polyatomic interferences can have numerous sources for example reagents used for preparation, sample matrix and other plasma gases (May and Wiedmeyer 1998; Taylor 2001).

### 2.6. DATA ANALYSIS

11 elements were chosen due to their significance with respect to chemotaxonomic information, bioactivity and toxicity (described in the introduction). The elements were grouped into rare earth elements (REE) or lanthanides (Yb, Ce and Tb), bioactive elements (Fe, Zn, Cu, Ni, Co, Mn and Cd) and possibly toxic element (Pb) based on different roles of the elements in the macro alga tissue. The elements were also sorted into different elemental quantities within each group for better comparison.

#### 2.6.1. CALCULATIONS AND STATISTICS

The quantitative and qualitative determination of elements in the algal samples was performed with HR-ICP-MS. A correction for background noise was made by subtracting the blank samples from the raw data so that only the algae tissue information could be analyzed. A relative standard deviation for the instrument was calculated and the final element (Appendix 6) concentration in the algal tissues was analyzed as micro gram per gram ( $\mu\text{g/g}$ ) dry weight. The element concentration in  $\mu\text{g/g}$  is always described as [element] in the result section (average  $\mu\text{g}$  element/g dry weight algal tissue = [Xx]).

An average of all the replicates within each species for both February 28<sup>th</sup> and May 6<sup>th</sup> were calculated. Microsoft Excel 2010 (Microsoft corp., Redmond, Washington, USA) was used to calculate averages, percentages and standard deviations ( $\pm 2$  SD) for all the elements, including plotting of the age zones and standard deviation in *S. latissima*. SPSS version 19 for Windows (IBM Corp., SPSS Statistics Inc, 2010, Armonk, New York) was used to make diagrams and graphs including plotting the standard variation values as well as variance

estimate, using MINQUE (Minimum Norm Quadratic Unbiased Estimation), for each element, in order to check the variation percentage within species, individuals within species and replicates within individuals. The principle of a variation estimate is to analyze the importance of different factors' contribution to the total variation based on sums of squares and the degrees of freedom (Df) (Rao 1971). StatGraphics (STATPOINT Technologies Inc., Warrenton, Virginia, USA) was used to conduct a Multi-factorial ANOVA on each element to check for differences between species, season and specimen amongst the brown algae. A Fisher's Least Significant Difference test (LSD) was done on the significant effects. All statistical analysis of the data was done with alpha set to 0.05.

The element concentration in *S. latissima* was excluded from the statistical tests of species and season variation due to different tissue sampling in May described in section 2.3.1. The red algae *V. lanosa* and the two green algae *C. rupestris* and *U. lactuca* were excluded from all statistical tests due to the lack of individuals within species and the number of species and therefore it was decided that there was not sufficient data for any valid statistical test. Also by looking at the raw data it was assumed that the Chloro-, Rhodo- and Phaeophytes were too different to be compared statistically on a species level (see Figure 18 in section 3.6.) and a separate analysis for each group might be necessary. Due to the lack of time after receiving the raw data, it was decided to mainly focus on the brown algae in this thesis.

### 3. RESULTS

#### 3.1. PHAEOPHYTE AND SEASONAL DIFFERENCES IN ELEMENT CONCENTRATION AND COMPOSITION

The Phaeophyte species presented in the figures of this section (Figure 7-17) are arranged according to zonation depth order, described in Figure 1 (section 1.2.), from the shallowest growing algae on the left (*P. canaliculata*) and to the deepest growing alga to the right (*L. digitata*). The corresponding standard deviation ( $\pm 2$  SD) values are shown with whiskers.

The Phaeophytes showed a significant ( $P < 0.00001$ ) difference in element concentration and composition where *F. serratus* differed the most from the others in both seasons. A zonation depth trend was also discovered for several elements where the species growing in the middle of the zonation depth had a higher [element] than the species growing in both extreme ends (*P. canaliculata* and *L. digitata*). The species that were significantly ( $P < 0.05$ ) different from all the other species with respect to each element are marked with a star (\*) in Figure 7-17 (see Appendix 1 for further statistical details).

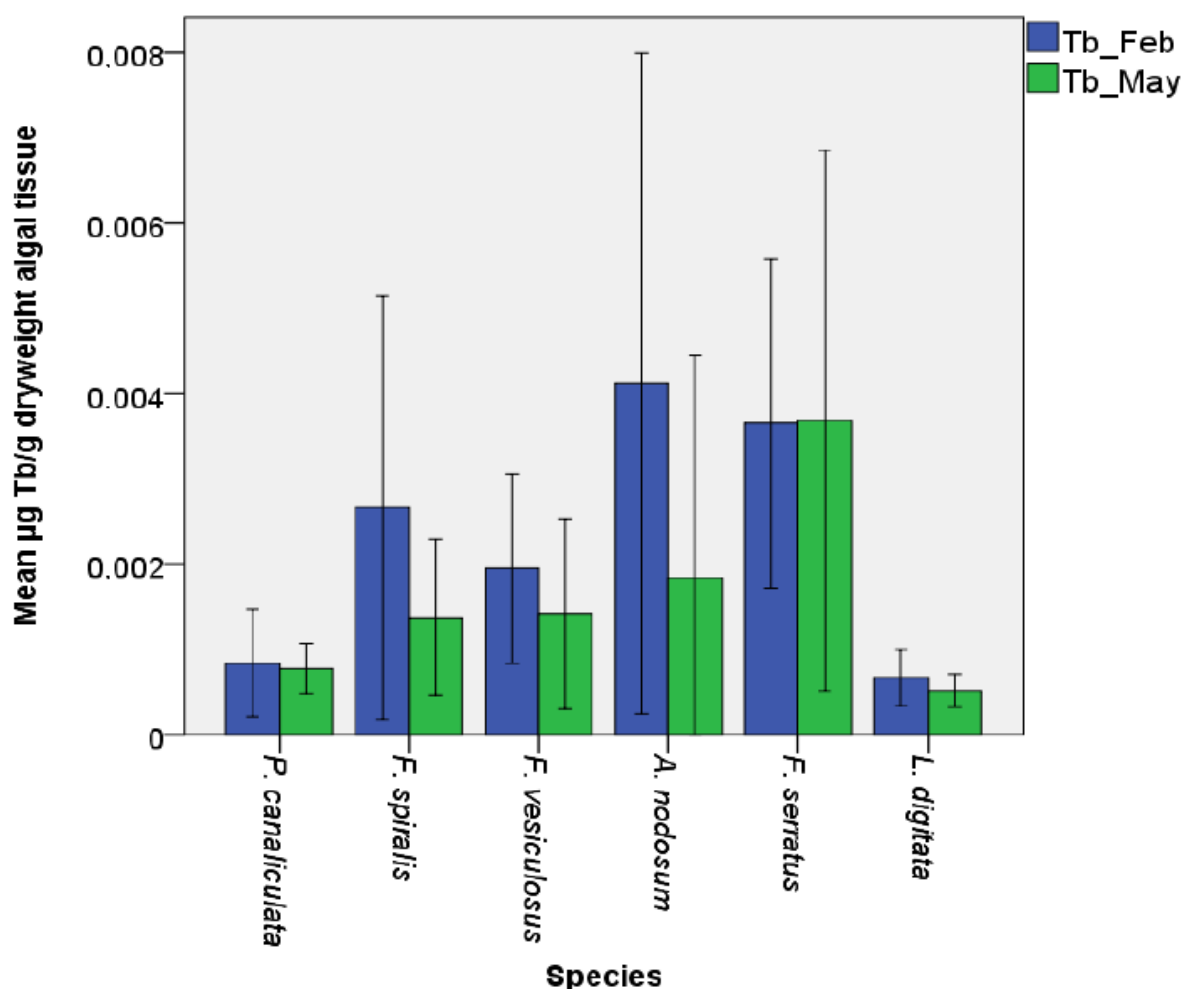
**Table 1.** The average difference (%) in [element] within all the Phaeophytes between February and May 2013. The month when the [elements] were highest is listed on the right.

Element	Difference (%)	Month with highest [element]
Fe	10	February
Cu	22.8	February
Cd	14.8	February
Co	15.4	February
Mn	17.9	February
Ni	18.2	February
Zn	16.5	February
Pb	50	February
Ce	6	May
Tb	17.9	February
Yb	4.6	February

There was on average a significantly ( $P < 0.0001$ ) higher [element] in algal tissue in all the Phaeophytes in February compared to May (see Table 1) except for the [Ce] which was higher in May. The average of all [element] differed with 18% between the two seasons.

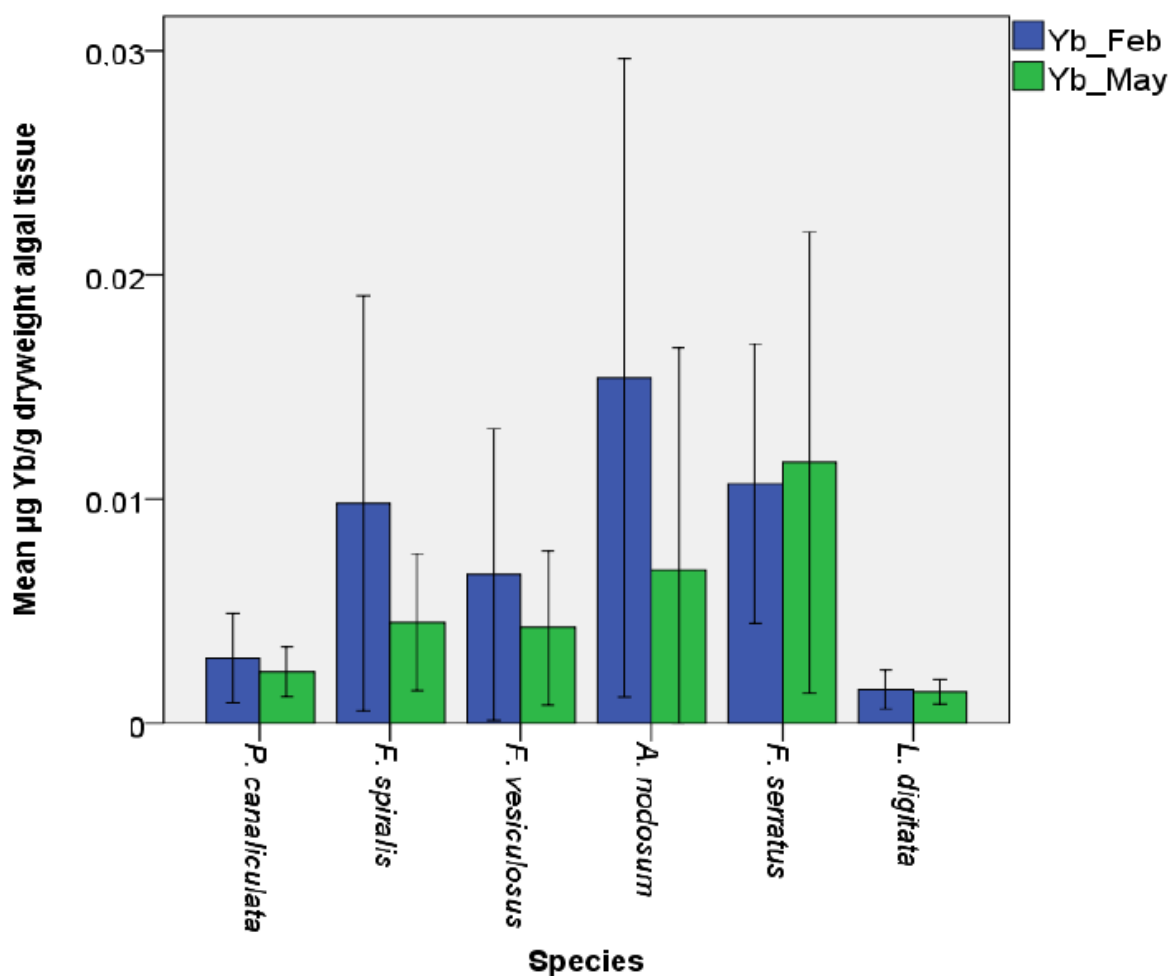
### 3.1.1. RARE EARTH ELEMENTS (REE)

The [REE] and REE composition in all the Phaeophytes (*P. canaliculata*, *F. spiralis*, *F. vesiculosus*, *A. nodosum*, *F. serratus* and *L. digitata*) for both seasons are shown in Figure 7, 8 and 9 below with corresponding standard deviations. All three [REE] (Tb, Yb and Ce) measured in this study followed the same pattern of distribution in all the Phaeophytes in both seasons.



**Figure 7.** Average weight ( $\mu\text{g/g}$ ) of the REE Terbium (Tb) in dry algal tissue of *Pelvetia canaliculata*, *Fucus spiralis*, *Fucus vesiculosus*, *Ascophyllum nodosum*, *Fucus serratus*, and *Laminaria digitata*, in February 28<sup>th</sup> (blue) and in May 6<sup>th</sup> (green). The corresponding standard deviation values ( $\pm 2$  SD) are expressed with whiskers on each column.

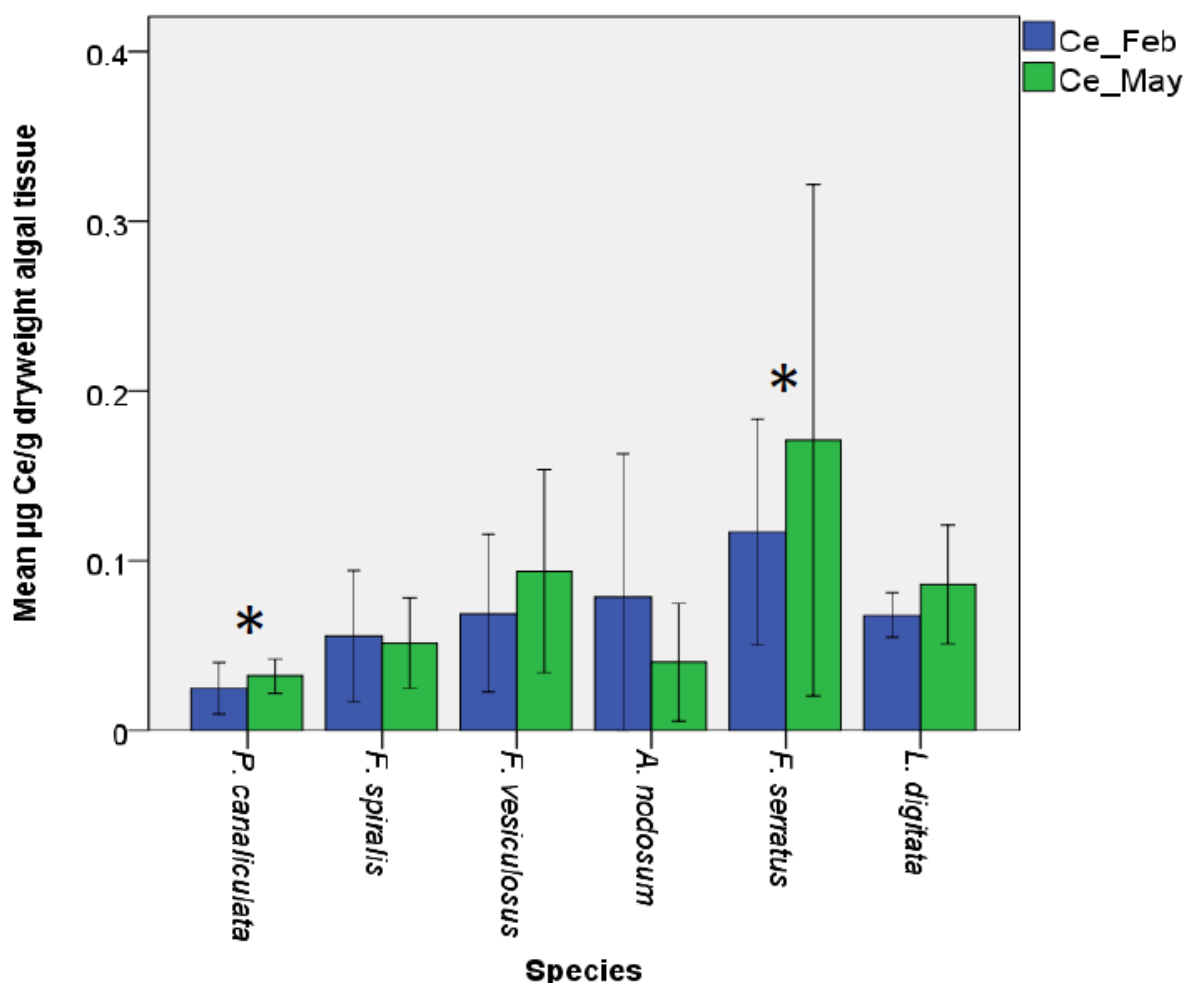
*Fucus serratus* and *A. nodosum* showed the highest [Tb] of all the species where *A. nodosum* contained a [Tb] of 0.0041 in February and *F. serratus* a [Tb] of 0.0036 in May. However, these two species are not significantly ( $P>0.05$ ) different from the rest of the brown algae measured. Correspondingly, *L. digitata* had smallest [Tb] in both seasons with 0.0005 in May and 0.0007 in February. A tendency towards a zonation depth trend in [Tb] can be seen in Figure 7 in both seasons.



**Figure 8.** Average weight ( $\mu\text{g/g}$ ) of the REE Ytterbium (Yb) in dry algal tissue of *Pelvetia canaliculata*, *Fucus spiralis*, *Fucus vesiculosus*, *Ascophyllum nodosum*, *Fucus serratus*, and *Laminaria digitata*, in February 28<sup>th</sup> (blue) and in May 6<sup>th</sup> (green). The corresponding standard deviation values ( $\pm 2$  SD) are expressed with whiskers on each column.

*Ascophyllum nodosum* contained the highest [Yb] of 0.015 in February and *F. serratus* of 0.011 in May. These were however not significantly different from the rest of the species ( $P>0.05$ ). *Laminaria digitata* had also here obtained the lowest [Yb] of 0.0015 in February and 0.0052 in May.

As well as for the [Tb], the [Yb] also showed a similar zonation depth trend where *P. canaliculata* and *L. digitata* had a smaller [Yb] than the species growing in the middle of the zonation depth.



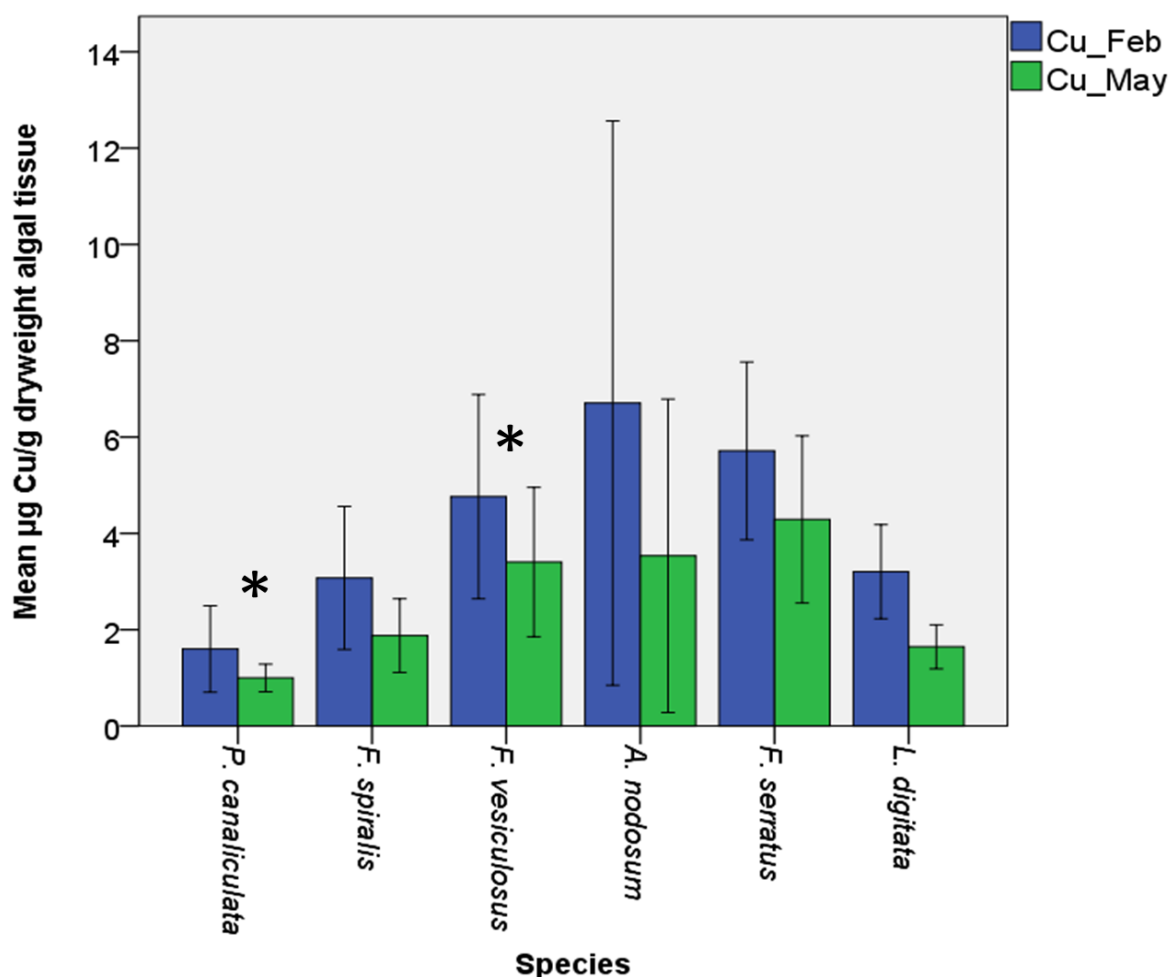
**Figure 9.** Average weight ( $\mu\text{g/g}$ ) of the REE Cerium (Ce) in dry algal tissue of *Pelvetia canaliculata*, *Fucus spiralis*, *Fucus vesiculosus*, *Ascophyllum nodosum*, *Fucus serratus*, and *Laminaria digitata*, in February 28<sup>th</sup> (blue) and in May 6<sup>th</sup> (green). The corresponding standard deviation values ( $\pm 2$  SD) are expressed with whiskers on each column. The species significantly different from the rest in both seasons are marked with a star (\*) above the columns.

In the last REE, *F. serratus* had a significantly ( $P < 0.05$ ) higher [Ce] than all the other species in both February (0.12) and in May (0.17). There was no significant ( $P = 0.11$ ) differences between the two seasons regarding [Ce] within the different species even though the [Ce] was dependent on both species and season as mentioned above. *Pelvetia canaliculata* had a significantly ( $P < 0.05$ ) lower [Ce] than the rest of the brown algae. Ce was the only element that had a higher average concentration in May as mentioned previously.



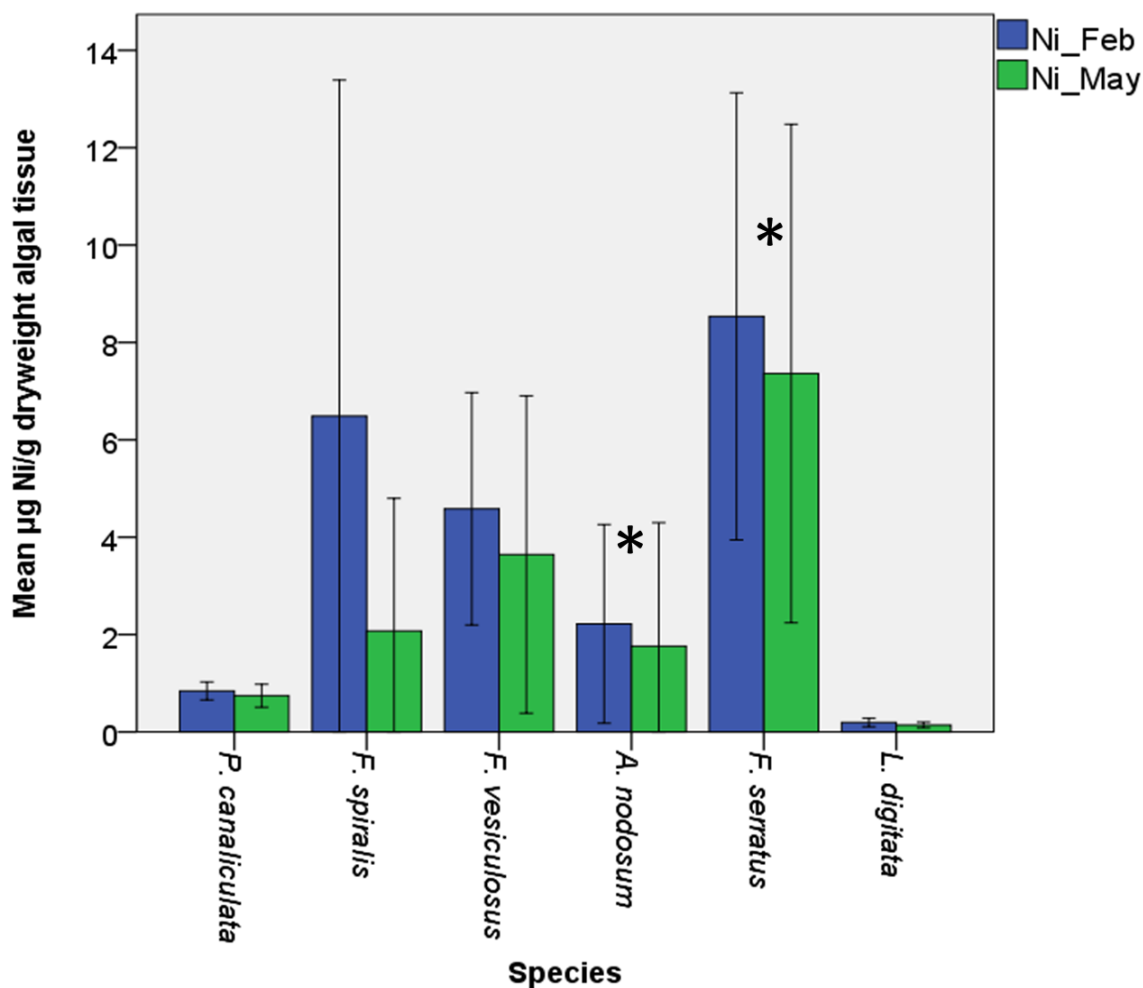
### 3.1.2. BIOACTIVE TRACE METALS

The [element] and composition for the bioactive trace metals within all the Phaeophytes (*P. canaliculata*, *F. spiralis*, *F. vesiculosus*, *A. nodosum*, *F. serratus* and *L. digitata*) for both seasons are shown in Figure 10-16 below with the corresponding standard deviations.



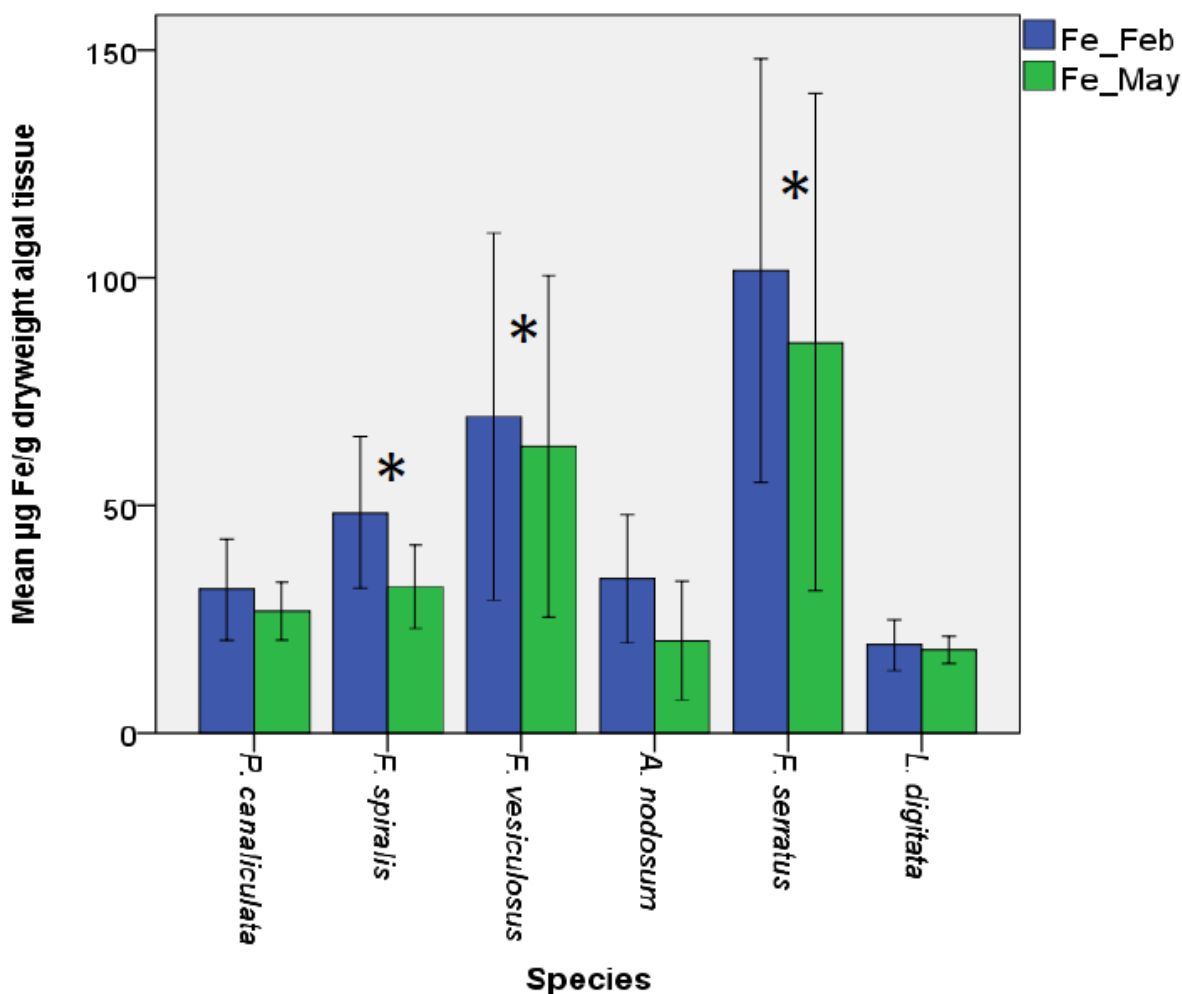
**Figure 10.** Average weight ( $\mu\text{g/g}$ ) of the bioactive trace metal Copper (Cu) in dry algal tissue of *Pelvetia canaliculata*, *Fucus spiralis*, *Fucus vesiculosus*, *Ascophyllum nodosum*, *Fucus serratus*, and *Laminaria digitata*, in February 28<sup>th</sup> (blue) and in May 6<sup>th</sup> (green). The corresponding standard deviation values ( $\pm 2$  SD) are expressed with whiskers on each column. The species significantly different from the rest in both seasons are marked with a star (\*) above the columns.

The highest [Cu] was found in *A. nodosum* in February (6.7) and in *F. serratus* in May (4.3). None of these two however were significantly different than all the rest. *Pelvetia canaliculata* had a significantly ( $P < 0.05$ ) lower [Cu] than all the other species. A clear zonation depth trend for [Cu] was also found in both seasons (especially in February) as the [Cu] decreased in both directions from the species growing in the middle of the zonation depth (*A. nodosum*).



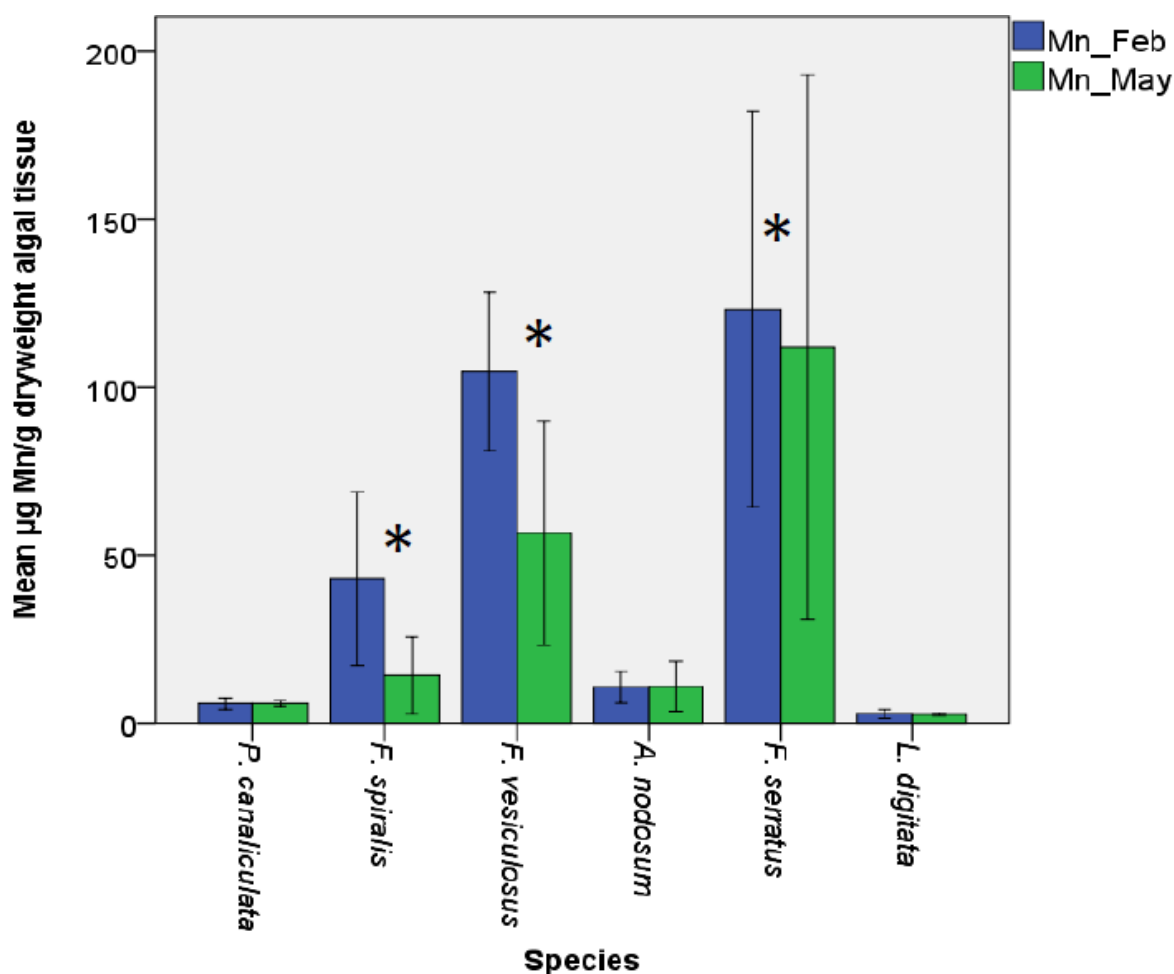
**Figure 11.** Average weight ( $\mu\text{g/g}$ ) of the bioactive trace metal Nickel (Ni) in dry algal tissue of *Pelvetia canaliculata*, *Fucus spiralis*, *Fucus vesiculosus*, *Ascophyllum nodosum*, *Fucus serratus*, and *Laminaria digitata*, in February 28<sup>th</sup> (blue) and in May 6<sup>th</sup> (green). The corresponding standard deviation values ( $\pm 2$  SD) are expressed with whiskers on each column. The species significantly different from the rest in both seasons are marked with a star (\*) above the columns.

The highest concentration of [Ni] in both seasons was found in *F. serratus* with 8.53 in February and 7.36 in May. The [Ni] in *F. serratus* was also significantly different from the other species along with the [Ni] in *A. nodosum* ( $P < 0.05$ ). *Laminaria digitata* had obtained the lowest [Ni] with only 0.19 in February and 0.14 in May but not a significantly ( $P > 0.05$ ) lower concentration than the rest of the species.



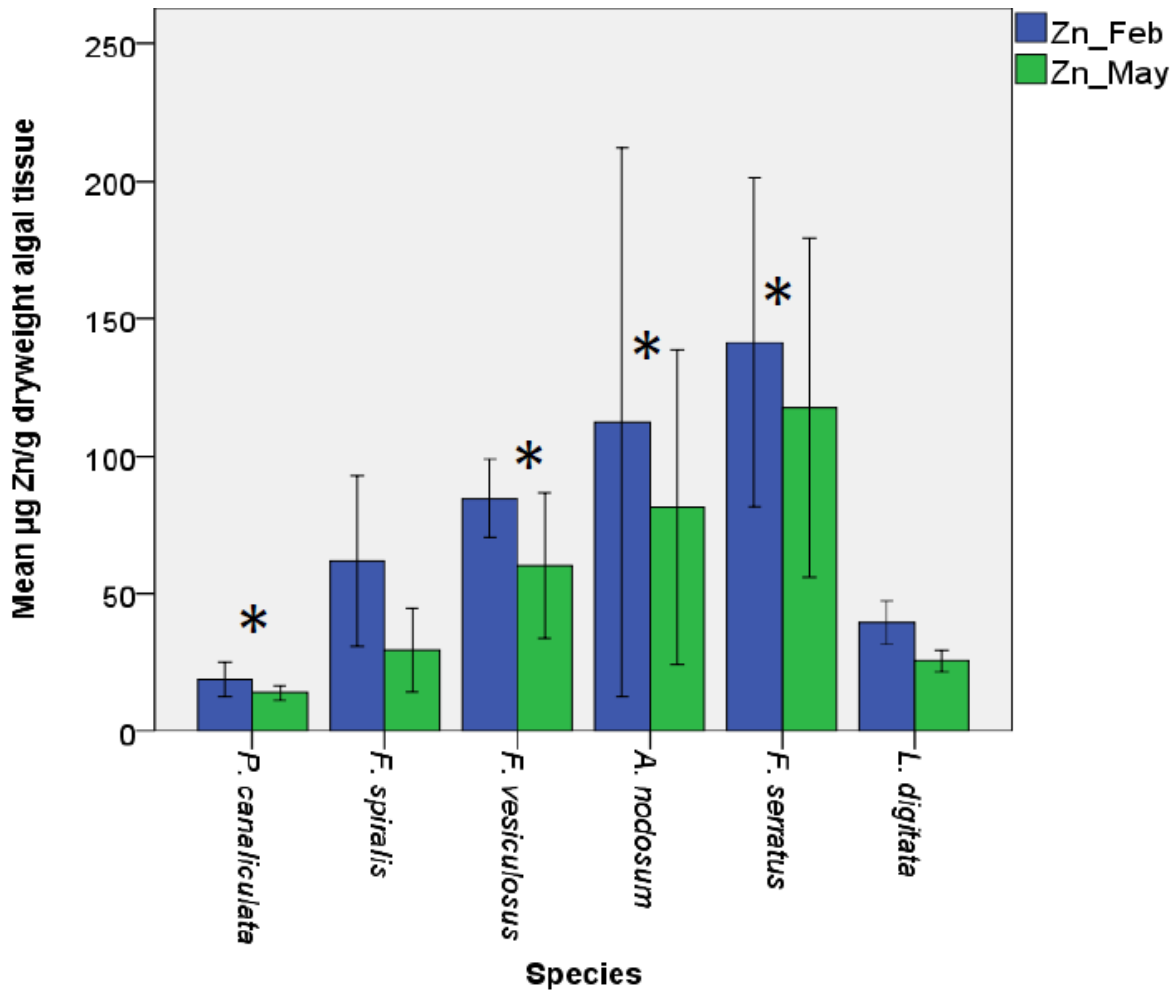
**Figure 12.** Average weight ( $\mu\text{g/g}$ ) of the bioactive trace metal Iron (Fe) in dry algal tissue of *Pelvetia canaliculata*, *Fucus spiralis*, *Fucus vesiculosus*, *Ascophyllum nodosum*, *Fucus serratus*, and *Laminaria digitata*, in February 28<sup>th</sup> (blue) and in May 6<sup>th</sup> (green). The corresponding standard deviation values ( $\pm 2$  SD) are expressed with whiskers on each column. The species significantly different from the rest in both seasons are marked with a star (\*) above the columns.

*Fucus serratus* contained a significantly ( $P < 0.05$ ) higher [Fe] in both February and May than all the other species. In addition, *F. vesiculosus* and *F. spiralis* also had significantly ( $P < 0.05$ ) different [Fe] than the rest of the species. *Laminaria digitata* had the smallest [Fe] of 19.4 in February and 18.3 in May although these concentrations were not significantly ( $P > 0.05$ ) lower than *A. nodosum* and *P. canaliculata*.



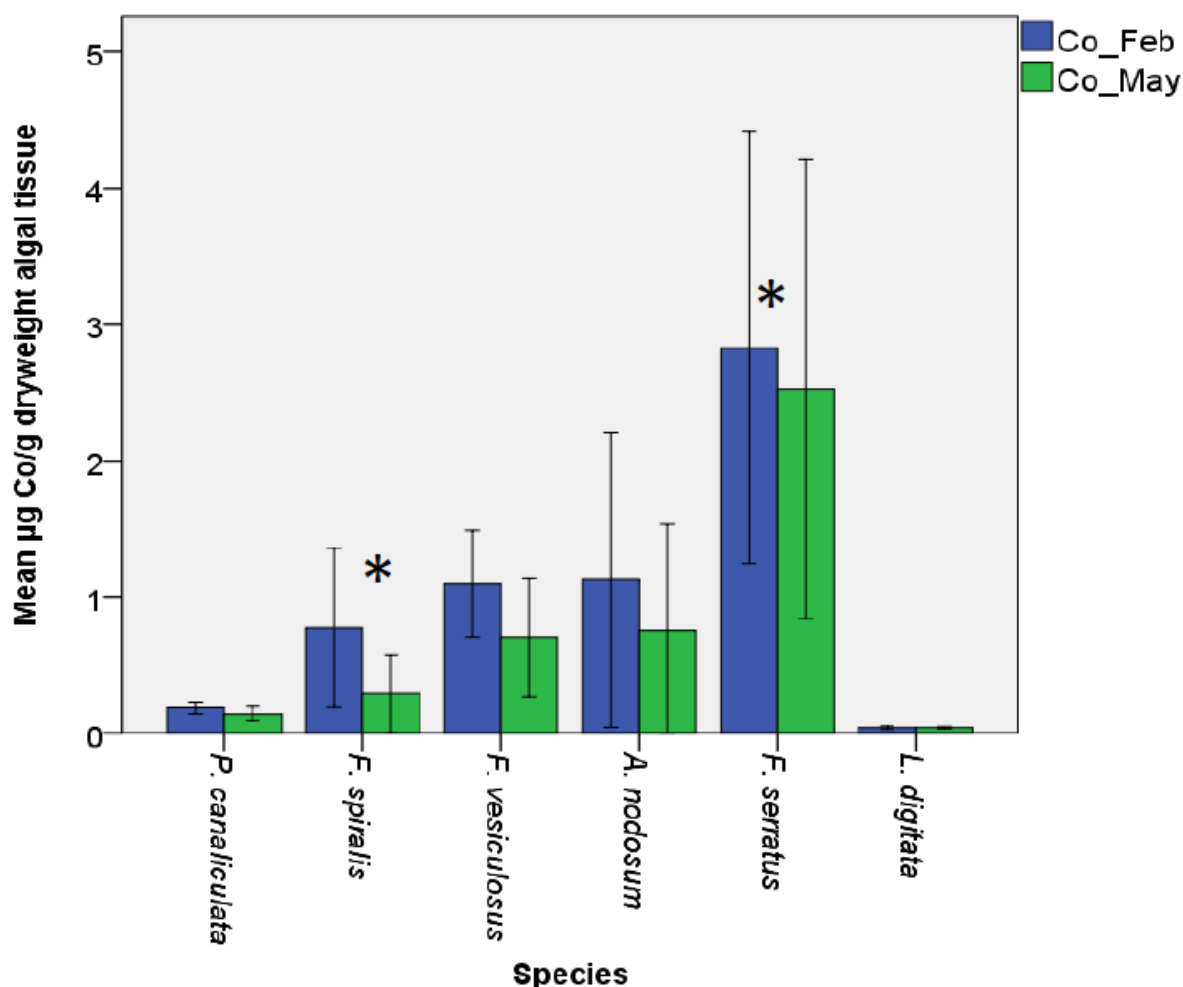
**Figure 13.** Average weight ( $\mu\text{g/g}$ ) of Manganese (Mn) in dry algal tissue of *Pelvetia canaliculata*, *Fucus spiralis*, *Fucus vesiculosus*, *Ascophyllum nodosum*, *Fucus serratus*, and *Laminaria digitata*, in February 28<sup>th</sup> (blue) and in May 6<sup>th</sup> (green). The corresponding standard deviation values ( $\pm 2$  SD) are expressed with whiskers on each column. The species significantly different from the rest in both seasons are marked with a star (\*) above the columns.

Three species, *F. spiralis*, *F. vesiculosus* and *F. serratus*, had significantly ( $P < 0.05$ ) different [Mn] than the rest of the other species where *F. serratus* had the highest [Mn] of 123 in February and 112 in May. *Laminaria digitata* had the lowest [Mn] ranging from 2.7 in February to 2.5 in May although these were not significantly ( $P > 0.05$ ) lower than *P. canaliculata* and *A. nodosum*.



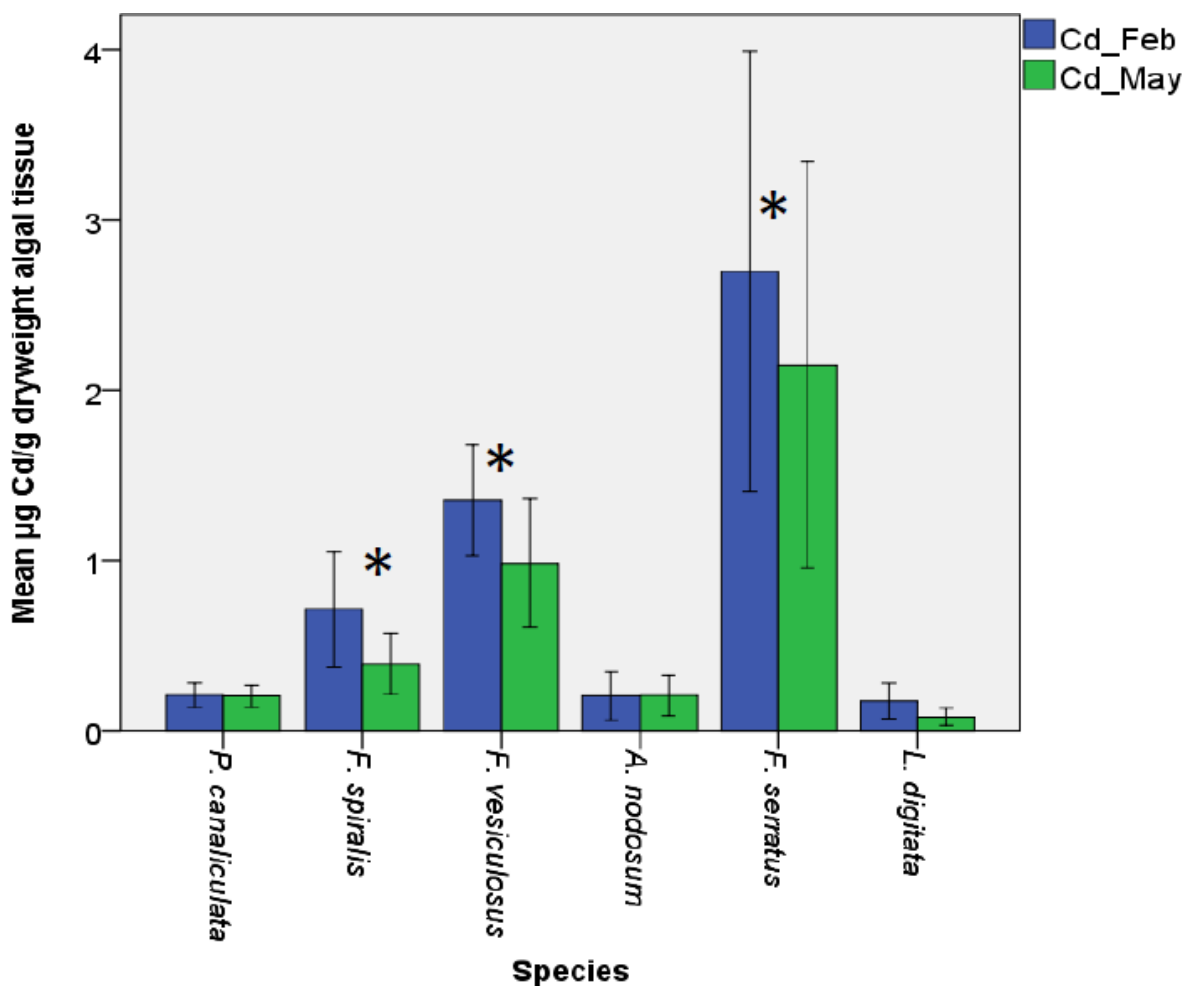
**Figure 14.** Average weight ( $\mu\text{g/g}$ ) of Zinc (Zn) in dry algal tissue of *Pelvetia canaliculata*, *Fucus spiralis*, *Fucus vesiculosus*, *Ascophyllum nodosum*, *Fucus serratus*, and *Laminaria digitata*, in February 28<sup>th</sup> (blue) and in May 6<sup>th</sup> (green). The corresponding standard deviation values ( $\pm 2$  SD) are expressed with whiskers on each column. The species significantly different from the rest in both seasons are marked with a star (\*) above the columns.

There was a significantly ( $P < 0.05$ ) different [Zn] between all the experimental species except for *F. spiralis* and *L. digitata*. The biggest [Zn] in both February (141) and May (117) was found in *F. serratus* whereas the smallest [Zn] was found in *P. canaliculata* with 18.8 in February and 14 in May. A zonation depth trend was found for the [Zn] as the [Zn] decreased towards both extreme ends (*P. canaliculata* and *L. digitata*). However, the [Zn] decreased in both directions from *F. serratus* which was found in the deeper end and not completely in the middle of the zonation depth.



**Figure 15.** Average weight ( $\mu\text{g/g}$ ) of Cobalt (Co) in dry algal tissue of *Pelvetia canaliculata*, *Fucus spiralis*, *Fucus vesiculosus*, *Ascophyllum nodosum*, *Fucus serratus*, and *Laminaria digitata*, in February 28<sup>th</sup> (blue) and in May 6<sup>th</sup> (green). The corresponding standard deviation values ( $\pm 2$  SD) are expressed with whiskers on each column. The species significantly different from the rest in both seasons are marked with a star (\*) above the columns.

*Fucus serratus* and *F. spiralis* were significantly ( $P < 0.05$ ) different from the rest of the species where *F. serratus* also had of the highest [Co] of all the species with 2.8 in February and 2.5 in May. *Laminaria digitata* had the lowest [Co] with 0.04 in both seasons but was not significantly ( $P > 0.05$ ) lower than *P. canaliculata*, *F. vesiculosus* and *A. nodosum*.

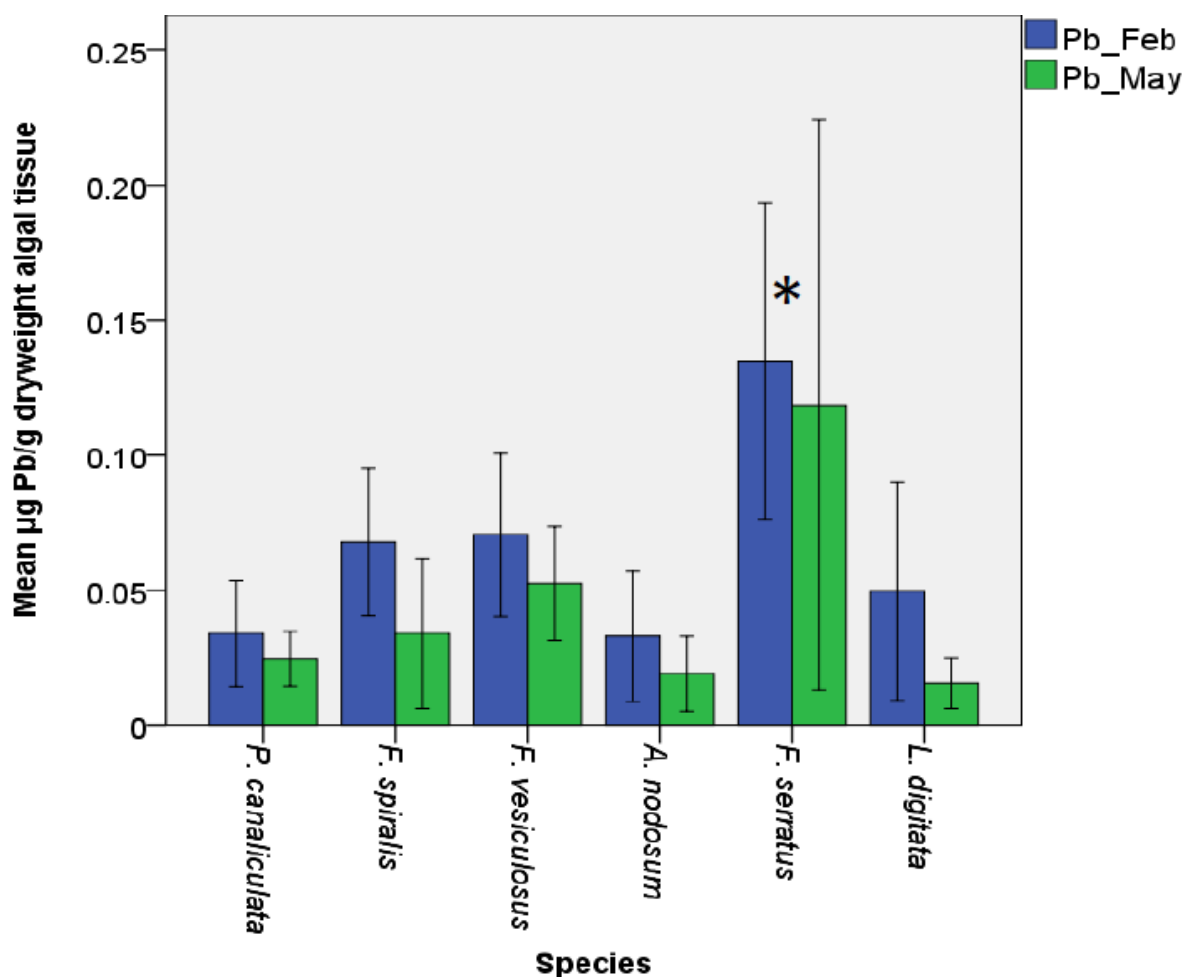


**Figure 16.** Average weight ( $\mu\text{g/g}$ ) of Cadmium (Cd) in dry algal tissue of *Pelvetia canaliculata*, *Fucus spiralis*, *Fucus vesiculosus*, *Ascophyllum nodosum*, *Fucus serratus*, and *Laminaria digitata*, in February 28<sup>th</sup> (blue) and in May 6<sup>th</sup> (green). The corresponding standard deviation values ( $\pm 2$  SD) are expressed with whiskers on each column. The species significantly different from the rest in both seasons are marked with a star (\*) above the columns.

The three species with the highest [Cd], *F. spiralis*, *F. vesiculosus* and *F. serratus*, were also significantly ( $P < 0.05$ ) different from the rest of the species. *Fucus serratus* obtained the highest [Cd] of 2.7 in February and 2.15 in May whereas *L. digitata* had the lowest [Cd] ranging from 0.17 in February till 0.08 in May. The [Cd] in *L. digitata* was not significantly ( $P > 0.05$ ) lower than *A. nodosum* and *P. canaliculata*.

### 3.1.3. TOXIC ELEMENT

The [Pb] within all the Phaeophytes (*P. canaliculata*, *F. spiralis*, *F. vesiculosus*, *A. nodosum*, *F. serratus* and *L. digitata*) for both seasons are shown in figure 17 below with the corresponding standard deviations.



**Figure 17.** Average weight ( $\mu\text{g/g}$ ) of Lead (Pb) in dry algal tissue of *Pelvetia canaliculata*, *Fucus spiralis*, *Fucus vesiculosus*, *Ascophyllum nodosum*, *Fucus serratus*, and *Laminaria digitata*, in February 28<sup>th</sup> (blue) and in May 6<sup>th</sup> (green). The corresponding standard deviation values ( $\pm 2$  SD) are expressed with whiskers on each column. The species significantly different from the rest in both seasons are marked with a star (\*) above the columns.

There was only one species, *F. serratus*, that had a significantly ( $P < 0.05$ ) different [Pb] of 0.13 in February and 0.12 in May. The lowest [Pb] was found in *A. nodosum* (0.03) in February and in *L. digitata* (0.08) in May although these were not significantly ( $P > 0.05$ ) lower than the other species.



### 3.2. VARIATION IN THE DATASET

The variation between species, individuals within species and replicates within individuals are listed in % in Table 2 below for all elements (see Appendix 4 and 5 for further details). The variation includes data from both May and February. This will provide a better understanding of the total variation in the dataset.

**Table 2.** An overview of the total variation in the dataset divided amongst the three different factors: variation between species of Phaeophytes, the variance between individuals within species and the variance between replicates within individuals in %. The average % is also showed in the bottom row. The value 0 is marked with a star (\*) as this value derived from a negative value in the variance estimate hence the true value of the variance equals zero.

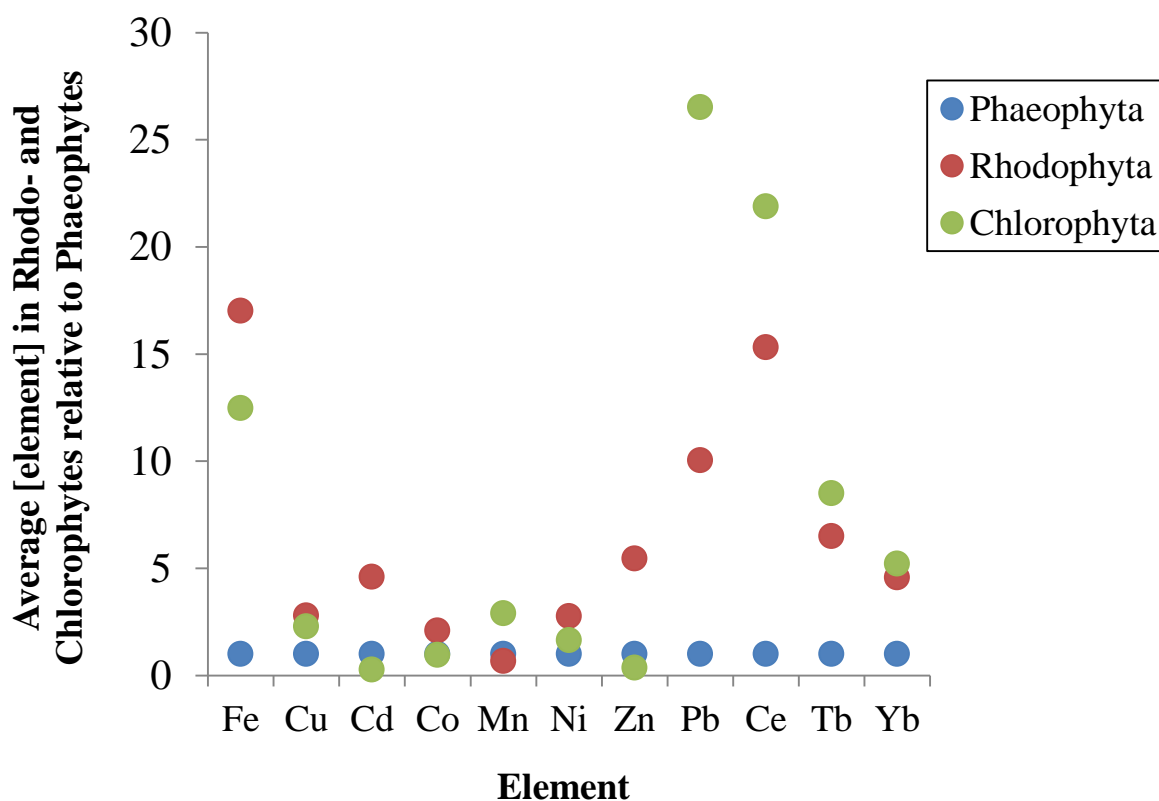
<b>Element</b>	<b>Variance between species (%)</b>	<b>Variance between Individuals within Species (%)</b>	<b>Variance between Replicates within Individuals (%)</b>
<b>Fe</b>	78.9	0.9	20.2
<b>Cu</b>	50.2	10.7	39.1
<b>Cd</b>	88.6	0*	11.4
<b>Co</b>	84	1.6	14.4
<b>Mn</b>	87.8	0*	12.2
<b>Ni</b>	68.4	3.9	27.7
<b>Zn</b>	73.2	5.6	21.2
<b>Pb</b>	49.9	0.2	49.9
<b>Ce</b>	47.8	4.4	47.8
<b>Tb</b>	49.5	12.8	37.7
<b>Yb</b>	44.7	15.5	39.8
<b>Average</b>	65.7	5.1	29.2

\*The variation is set to 0 due to negative values in the variation estimate. This can happen when the true value of the variance approaches zero or the specific model is not the correct model.

The variation in the dataset was greatest between the different Phaeophytes with an average of 65.7%. The smallest variation with the average of 5.1% was found between the different individuals. The rest of the variation in the dataset was found within the different individuals (replicates) with an average of 29.2%.

### 3.3. DIFFERENCE IN ELEMENTAL COMPOSITION BETWEEN PHAEO-, RHODO- AND CHLOROPHYTES

Figure 18 shows the average of [element] in the Chloro- and the Rhodophytes divided by the average [element] in the Phaeophytes. The Phaeophyte [element] were set to 1 and the two other algal classes are shown relative to this value.

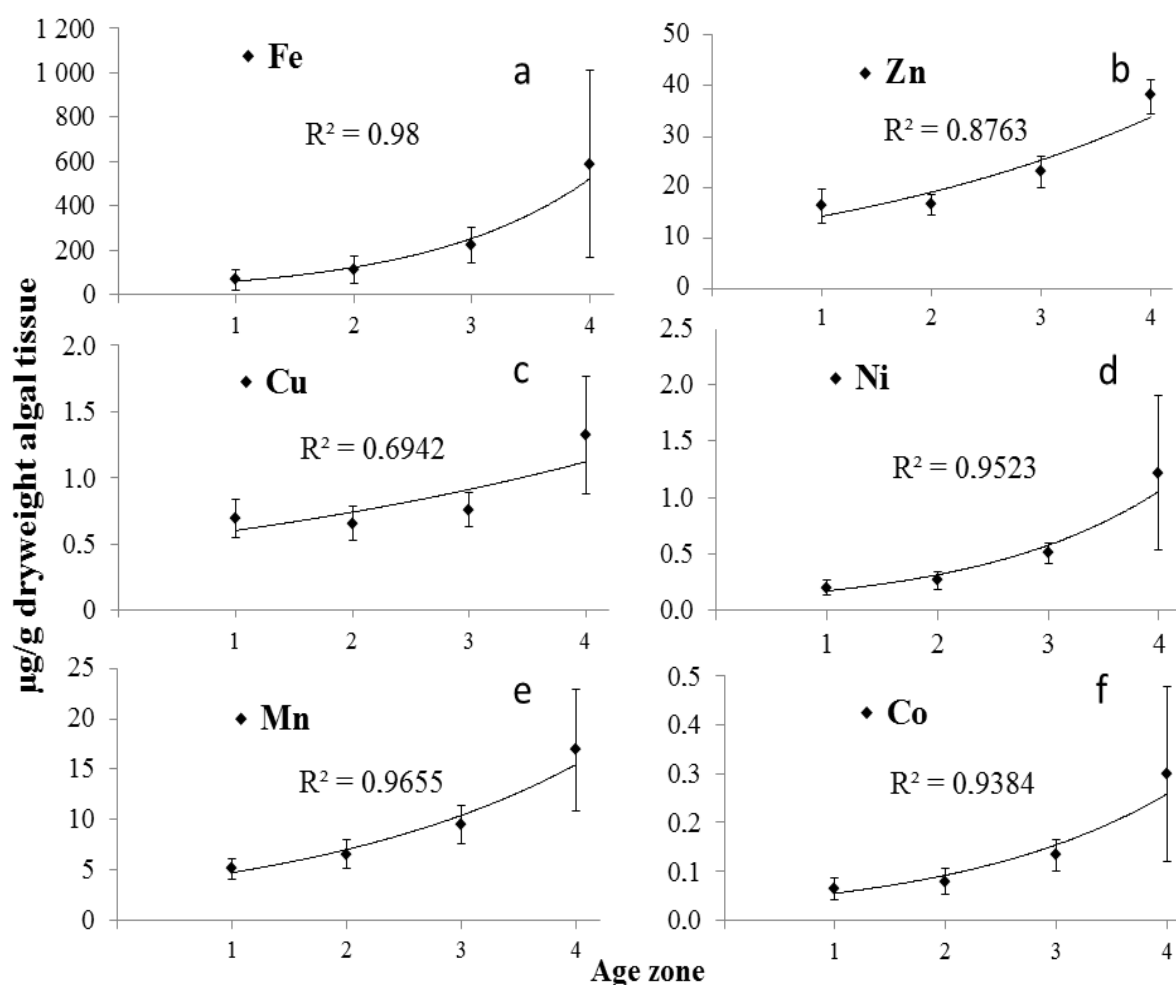


**Figure 18.** The average [element] in the Rhodo- and Chlorophytes divided by the average [element] in the Phaeophytes. The different [elements] are shown on the X-axes and the three algae classes are Phaeophytes (blue), Rhodophytes (red) and Chlorophytes (green).

There was a large variation in average [elements] between the three algal classes and the Rhodophytes and the Chlorophytes had generally higher and sometimes 5-27 times higher [element] than the Phaeophytes (see Figure 18). For the bioactive elements (Cu, Cd, Co, Mn, Ni and Zn) the [element] were more similar between the three algal classes, however Fe (also a bioactive element) differed with the magnitude of 13 and 17. The Chlorophytes had a higher concentration of REE and Pb than both the Rhodo- and Phaeophytes where the [Pb] was 27 times higher in Chlorophytes than in Phaeophytes.

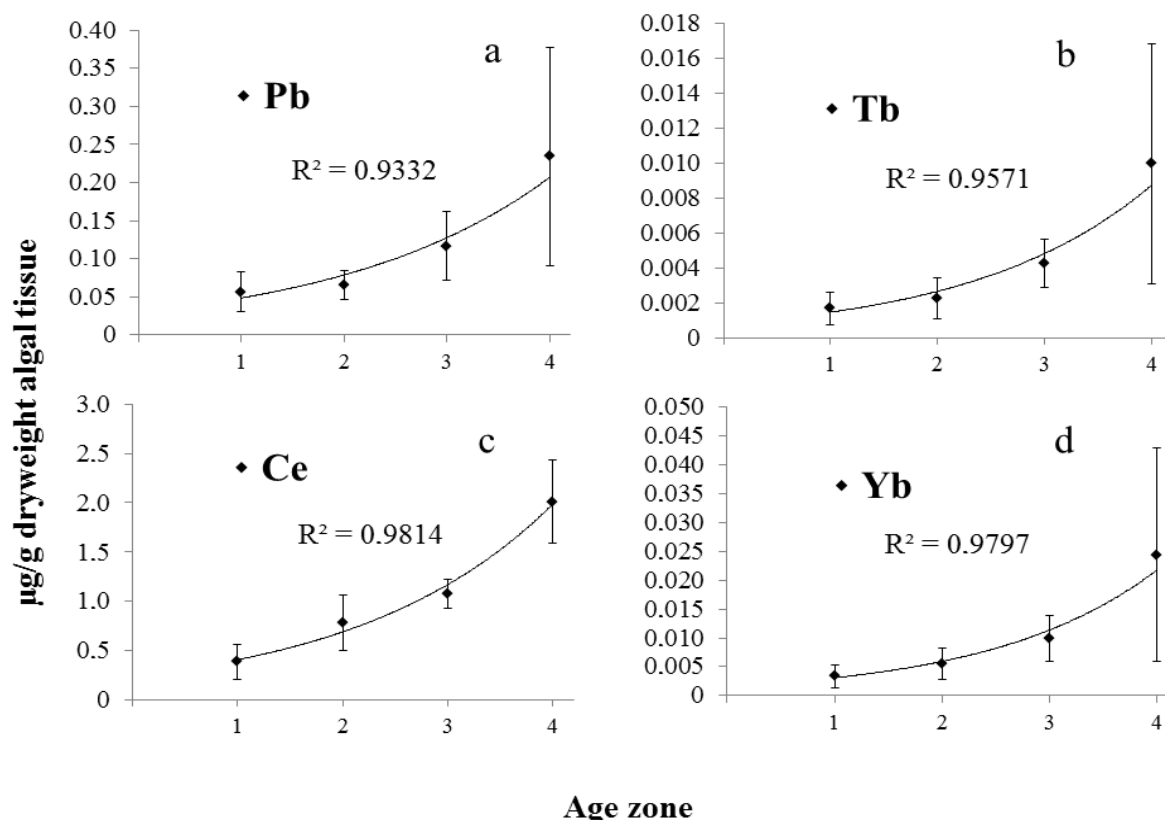
### 3.4. [ELEMENT] DIFFERENCES IN *SACCHARINA LATISSIMA* WITH RESPECT TO TISSUE AGE

The element composition in *Saccharina latissima* in May as a function of tissue age is presented in figures 19-21. There was a clear increase with age in all the elements, except for Cadmium (see Figure 21). Age zone 4 was significantly ( $P < 0.05$ ) different in element concentration from all the other age zones (see Appendix 2 for statistical details).



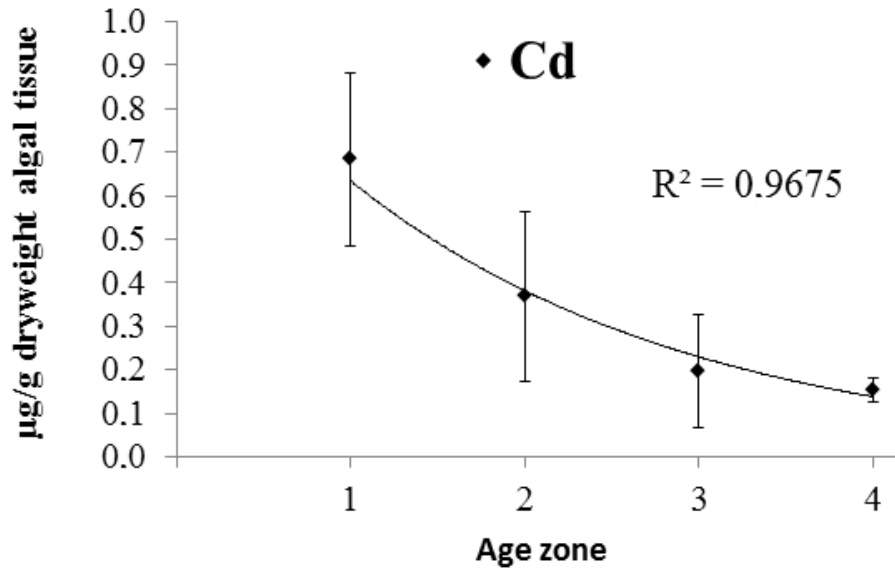
**Figure 19.** Bio-active elements in *S. latissima* as a function of tissue age (1-4). Average  $\mu\text{g/g}$  of dry algal tissue of a) Iron (Pb), b) Zink (Zn), c) Copper (Cu), d) Nickel (Ni), e) Manganese (Mn) and f) Cobalt (Co in *S. latissima* the 6<sup>th</sup> of May in four different age zones including the standard deviation measured for each age zone (see Figure 5). An exponential regression line with its corresponding  $R^2$  is also presented. The age zones are described here as 1-4 where 1 is an average of the youngest tissue in three different *S. latissima* and 4 is an average of the oldest tissue in the same algae. Age zone 2 and 3 are the middle age tissue samples where age zone 2 is younger than age zone 3. Note the scale differences.

There was a positive exponential relationship between the concentration of the bioactive elements (Fe, Zn, Cu, Ni, Mn and Co) and age in *S. latissima* (see Figure 19a, b, c, d, e and f). The standard deviation values were generally higher in the oldest tissue (age zone 4) than in the younger tissues (age zone 1, 2 and 3) with Zn as the only exception where the standard deviation values were more similar in all the age zones (see Figure 19b).



**Figure 20.** Average REE and Lead ( $\mu\text{g/g}$  of dry algal tissue) as a function of tissue age (note the scale difference) of a) Lead (Pb), b) Terbium (Tb), c) Cerium (Ce) and d) Ytterbium (Yb) measured in *Saccharina latissima* in four different age zones (see Figure 20) including the standard deviation measured for each age zone. Terbium, Cerium and Ytterbium are lanthanides (REE) whereas Lead is a toxic element. An exponential regression line with its corresponding  $R^2$  is also presented. The age zones 1-4: 1 is an average of the youngest tissue in three different *S. latissima* and 4 is an average of the oldest tissue in the same algae. Age zone 2 and 3 are the middle age tissue samples where age zone 2 is younger than age zone 3.

There was also a clear positive exponential relationship between the concentration of the elements (Yb, Tb, Ce and Pb) and the age in *S. latissima* (see figure 9a, b, c and d). The standard deviation values for all the elements were also here higher in the oldest tissue (age zone 4) than the younger.



**Figure 21.** Cadmium in *S. latissima* as a function of tissue age. Average µg/g dry algal tissue of Cadmium (Cd) in four different age zones (see Figure 5) including the standard deviation measured for each age zone. An exponential regression line with its corresponding  $R^2$  is also presented. The age zones 1-4 indicates that 1 is an average of the youngest tissue in three different *S. latissima* and 4 is an average of the oldest tissue in the same algae. Age zone 2 and 3 are the middle age tissue samples where age zone 2 is younger than age zone 3.

There was a negative exponential relationship between Cd concentration and age in *S. latissima* (see Figure 21). The standard deviation values were higher in the younger tissues (age zone 1, 2 and 3) than the oldest (age zone 4).

## 4. DISCUSSION

The results from this study show that there are significant differences in element composition and concentration between the different species within the Phaeophytes, although some species were more different from the rest than others. *Fucus serratus* had a significantly higher [element] than all the other species for Ce, Ni, Fe, Mn, Zn, Co, Cd and Pb whereas *L. digitata* and *P. canaliculata* had the lowest [element] for all the measured elements. However, these were not always significantly different from the rest of the examined species. This difference in [element] and composition is most likely due to various biological and structural differences among species as well as the environmental factors that interact with both the species and elements. Some results indicate that either environmental factors or biological factors have the most influence on the [element] in algal tissue depending on species and element. The similar pattern of the REE in the different Phaeophytes ([Ce], [Tb] and [Yb]) indicates an environmental rather than biological influence on [REE] in the algal tissue which supports the theory that the REE have no biological role in the algal cell (Evans 1983; Panagiotopoulos et al. 2010).

### 4.1. ZONATION DEPTH TREND

Studies done by Fuge and James (1973) and Foster (1976) both found that trace metal concentration among different species of macro algae varies according to the position on the shore due to a difference in immersion or exposure time to air. They therefore concluded that tidal cycles have an influence on trace metal concentration in macro algae. These findings are consistent with the results in this study. The results also show a tendency of a higher [element] in the species located in the middle of the zonation depth indicating that the tide, hence the sea-surface micro layer (SML) discussed in section 4.2.2., might also play a very important role in element adsorption (attachment of , here, elements to surface of algal tissue). This trend is especially clear for the [Cu], [Zn] and [Yb] as shown in Figure 10, 14 and 8, respectively. Stengel et al (2004) did a study on [Zn] in *F. vesiculosus* and did also find a similar trend with high [Zn] in algae located in the middle of the zonation depth, which is in accordance with Fuge and James (1973) who found the same for [Zn] and [Cd].

The environmental and biological factors explained below for the zonation depth trend might just apply to some elements as for example Figure 11 shows, indicating that [Ni] in algal tissue is more dependent on metal speciation or species' metabolic differences.

## 4.2. ENVIRONMENTAL FACTORS

### 4.2.1. BOUNDARY LAYER AND SUBMERSION TIME

Since trace metal accumulation in macro algae is dependent on the thickness of the boundary layer (Wheeler 1980) and the amount of time actually exposed to the elements (Tessier and Campbell 1987), it can be assumed that algae with the thinnest boundary layer and longest submersion time obtain the highest [element]. *Pelvetia canaliculata*, which is growing in the uppermost layer of the zonation depth, is exposed to air for a longer time than species located further down the zonation depth and therefore has a lower [element] than the other species as a result. The low [element] in *L. digitata*, which grow at the deepest end of the zonation depth, could be a result of a thicker boundary layer due to its mucilage layer (Salaün et al. 2012) as this is very viscous and might make diffusion of elements harder. The mucilage, which consists of mainly sugar, is thought to have different functional groups with great biosorption abilities of various trace metals (Percival and McDowell 1967). Even though the mucilage adsorb elements, it can be assumed that it has a greater effect as a boundary layer (inhibiting absorption) based on the founding of Markham et al. (1980), where the stipe of the laminarean *S. latissima* had a higher [Cd] than the other parts of the plant, and the fact that the stipe is the only part of the laminareans that does not produce mucilage (Rueness 1977).

The wave action along the littoral zone results in re-suspension of sediments and mobilization of suspended matter, which in turn leads to a greater availability of elements (Tessier and Campbell 1987). This may lead to the variation in [element] in the algal tissue along the zonation depth as the re-suspension and the mobile suspended matter differ according to topography and water movements. Even though the submersion time is great for *L. digitata* the boundary layer (mucilage) is limiting the element flux and there is less suspended and re-suspended matter available whereas *P. canaliculata* experiences high element availability due to more wave action, hence more mobile sediments, along with little submersion time. It seems like *P. canaliculata* and *L. digitata* have the opposite problems when it comes to element absorption and accumulation as these species are located on the opposite ends of the zonation depth.

#### 4.2.2. SEA SURFACE MICRO LAYER (SML)

Since the sea surface micro layer (SML) has between 10 to 1000 times higher concentrations of trace metals than the water below (Hunter 1997), it can be assumed that the macro algae that have a lot of contact with the SML have the chance to absorb or accumulate higher concentrations of trace metals than the macro algae with less contact with the SML. As the tide moves up and down the zonation profile, the SML will move according to this and make contact with the different species of macro algae at different times (see Figure 1 in section 1.2. and Figure 22 in section 5.). It is reasonable to assume that the macro algae located in the middle of the zonation depth (*F. vesiculosus*, *A. nodosum* and *F. serratus*) is more exposed to the SML than the macro algae located on the extreme ends of the zonation profile since these are located approximately in the same depth as the mean tide. These species will then have higher concentration of trace metals with a decreasing trend toward both extreme ends as shown in the results.

### 4.3. BIOLOGICAL FACTORS

#### 4.3.1. CELL STRUCTURE AND FUNCTION

There was a greater difference within each individual alga than between individuals within the same species as shown in Table 2. Hence, it can be assumed that the biggest biological variation lies within the algal tissue and between the algal cells rather than between individuals of the same species. Valle (2005) did some studies that showed great differences in structure amongst the cells of the red alga *Palmaria palmata*, the green alga *U. lactuca* and the brown alga *S. latissima* with respect to season. Valle (2005) also showed great differences within the different parts of the algae, which agrees with the results of this thesis and the choice of only sampling the youngest tissue (meristem). When the cell structure varies within individuals and between species, it is reasonable to believe that the cell function will differ too. According to Fourest and Volesky (1995), cell wall structure plays an important role in absorption of trace metals whereas these structures can vary greatly among species. The physiological differences between species consist of photosynthetic response, nutrient uptake and growth rates (Sawidis et al. 2001). Carboxylic groups located on the cell wall (see Figure 22) are directly linked to metal absorption and they also participate in the ion exchange and interaction (Myklestad 1986). The interaction between trace metals and their ions can for example be occupation and competition of different binding sites on the algal cell wall (Foster 1976). Even though these cell structures vary between species, the results indicate that they



vary even more within the individual. It can then be assumed that structural and functional differences within each individual play an important role in the element composition and concentration in macro algae.

#### 4.3.2. SUGAR CONTENT

*Ascophyllum nodosum* did not always follow the zonation depth trend with a lower concentration of some elements even though it was located in the very middle of the zonation depth profile (see Figure 1). This could be explained by the very high alginate in *A. nodosum* as this species contains a lot of this compound compared to the rest of the Fucooids and *L. digitata* (Holan et al. 1993; Black 1948). The fact that there is different sugar speciation and content in different species (Black 1954) might affect the element weight per dry weight algal tissue ratio as the element concentration will be diluted by high sugar contents. This is especially clear for [Ni], [Fe], [Mn], [Co], [Ce], [Pb] and [Cd] but not so clear for [Zn], [Cu], [Yb] and [Tb], as shown in figures 7-17. Foster (1976) also found generally a lower [element] in *A. nodosum* than in *F. vesiculosus* which are positioned next to each other in the littoral zone. It is clear that *A. nodosum* has a different biological character than the rest of the brown algae as this species also contains a unique mixture of polysaccharides that easily bind to metal ions (Black 1954). The effect of *A. nodosum*'s ability to bind elements can be seen in Figures 7, 8, 10 and 14 (in section 3.) where it has obtained high [element] despite the high alginate and other sugar content per dry weight. If the sugar content was taken in consideration, an even higher [element] for Zn, Cu, Tb and Yb would most likely be seen per dry weight of *A. nodosum*.

The low [element] in *L. digitata* could in addition to the previously mentioned environmental factors be explained by the high levels of sugar and mucilage found in the Laminarean species (Martone 2007; Percival and McDowell 1967). Even though the carboxyl groups on the algal tissue are said to adsorb trace metal, the amount of sugars in the dry weight of *L. digitata* will have a great effect on the dry weight to element ratio, resulting in a lower [element] per dry weight. *Fucus serratus* obtained a high [element] and often higher compared to the other species (see Figures 9, 11, 12, 13, 14, 15, 16 and 17 in section 3.). Due to its zonation depth position in the littoral zone it does not need that much alginate to withstand wave action hence it has in total less sugar than the other Fucooids (Black 1954). This creates an opposite effect on the dry weight to element ratio than for *L. digitata* and *A. nodosum* as these species contain more sugars. An additional explanation for the sometimes lower [element] in *A. nodosum*

could be that the passive adsorption of [Fe], [Mn], [Pb], [Ni] and [Cd] is less active than the adsorption of the other measured elements due to unknown chemical or biological reasons.

#### 4.4. SEASONAL DIFFERENCES IN ELEMENTAL COMPOSITION AND CONCENTRATION

There was an average of 18% higher [element] in February than in May as shown in Table 1 for the Phaeophytes. Some elements showed a higher variation between the two seasons than others and [Ce] stood out as the only element with a higher concentration in May. The higher [element] within the macro algae tissue in February is likely due to less element uptake from the water masses due to the depletion of nutrients by phytoplankton in the spring bloom (Sjøtun 1995). This might also apply for REE and Pb, despite the fact that these are not considered a nutrient for algae. Either the macro algae have developed their own strategy through evolution of storing trace metals mainly during winter time, the major growth season of Laminareans (Sjøtun 1995), or this is a result of competition for trace metals with the phytoplankton.

The results also showed a significantly higher [element] within the Phaeophyte tissue in winter, which can be due to the continuous growth of algal tissue during May (summer) (Mathieson et al. 1976), little available nutrients (Sjøtun 1995) and the assumption that macro algae cannot regulate the trace metal uptake (Gutknecht 1965). It is therefore reasonable to assume that there will be a dilution of [trace metal] in the algal tissue in summer compared to February (winter), as the results showed, due to lower element availability in summertime. Foster (1976) also concluded that a seasonal variation in trace metal concentration in macro algae is due to differences in growth rate.

In addition to the above-mentioned reasons, seasonal differences in [element] might also be due to physical conditions in the area. During one year the weather can vary a lot according to what season it is or just random occurrences in certain areas in form of precipitation, wave action, run-off from land, salinity, temperature, pH, light (hence photosynthesis) and many more. The pH and salinity in water have an effect on the metal speciation affecting the bioavailability of the elements (Fuge and James 1973). These physical factors however were not measured or accounted for in this thesis. Since the algal samples were only taken in February and May, a yearly variation in [element] and composition is not discussed in this thesis.

#### 4.5. ESTABLISHING BASIS LEVELS OF [ELEMENT] IN ALGAL TISSUE

The results show that [Cu] and [Zn] in *A. nodosum* are lower in this study compared to results of these elements in the same species done in 1973 and 1987, near Brænnebukta (Jensen et al. 2000). The different methods used in this study and in earlier studies should be taken in consideration as this might affect the results. The results also range within the *A. nodosum* “basis level” measured in Lofoten in 1973 (Jensen et al. 2000) hence indicating a “normal or healthy” level of Zn, Cu and Cd in the algae tissues near Brænnebukta today. Establishing basis levels of trace metals in macro algae can be difficult as there is little data regarding trace metals (especially with respect to REE) and the ocean is ever changing. To establish a true basis level of elements in macro algae in Brænnebukta there is also a need for measurements of [elements] in seawater as well as a complete understanding of the metal speciation and macro algal biology.

#### 4.6. DIFFERENCES IN ELEMENT COMPOSITION BETWEEN PHAEO-, RHODO- AND CHLOROPHYTES

The [element] were generally higher in the Rhodophytes and the Chlorophytes compared to the Phaeophytes. In some cases ([Pb], [Fe], [Yb], [Tb], and [Ce]) the Phaeophytes had between 5 and 27 times lower [element] than the two other algal classes.

It is therefore safe to assume that these three classes are too different to be compared on a species level and also that Rhodophytes and Chlorophytes generally adsorb and accumulate higher [element] than Phaeophytes. A comprehensive study on elements amongst these three algal classes by Ryan et al. (2012) found *V. lanosa*, (Rhodophyte) to have the highest concentration factor ever reported of any seaweed. The concentration factor was measured as algal tissue [element] divided with the water [element]. The results of this study show that *V. lanosa* had a higher [element] for all elements even though it was located on the sampled *A. nodosum*, which makes the results consistent with Ryan et al. (2012)’s conclusion. A high [Zn] concentration was found in *V. lanosa* (see Figure 18) along with a low [Mn], which was in fact the smallest concentration of all elements in this species. In phytoplankton, the uptake of Mn is inhibited by Zn due to binding site competition (Sunda and Huntsman 1995) and this could also be the reason for the Zn-Mn relationship shown in the results for *V. lanosa*.

Both Rhodophytes and Phaeophytes have a greater amount of certain matrix polysaccharides than Chlorophytes, making them more able to absorb trace metal (Schiewer and Volesky 2000). This conclusion fits with the results for *V. lanosa* but not that well for the Phaeophytes. The Chlorophytes however showed higher [element] than all the Phaeophytes (except for [Cd] and [Zn]), especially *C. rupestris*. The results actually show that Chlorophytes might be better trace metal accumulators than Rhodophytes and also Phaeophytes, especially with respect to the REE and Pb. Sholkovitz (1995) concluded that there are high concentrations of REE in rivers due to soil erosion and this might be a main source of REE input into the ocean. The Chlorophyte *C. rupestris* can tolerate a lot of freshwater and is therefore often found in shallow areas close to river outlets or near melting ice (Rueness 1977). Hence it would be expected to find high concentrations of REE in this species (see Figure 18 in section 3.3.). Another reason for the high [element] could be contamination by human activity as the Chlorophytes were picked at the very top of the zonation depth. This, however, might also apply for *P. canaliculata* and *F. spiralis* as these were also picked in the uppermost parts of the littoral zone.

#### 4.7. ELEMENT CONCENTRATION DIFFERENCES IN *SACCHARINA LATISSIMA* WITH RESPECT TO TISSUE AGE

The [element] in *S. latissima* increased exponentially with respect to age for all elements with Cd as the only exception (negative exponential relationship with age) as shown in Figure 19-21. Since it is believed that algae cannot regulate their uptake of trace metals (Bryan 1969) it is safe to assume that for all the elements except Cd, age (time) will increase the total amount of [element] within the algal tissue, as older tissue has had a longer exposure time to available elements. The rate of accumulation with respect to age was in this case exponential, but it is difficult to say whether this is consistent for *S. latissima* or if it reflects the [element] in water at the time, as this might vary a lot depending on geography and time.

For the [Cd] in *S. latissima*, the above mentioned does not seem to be the case. There was a lower [Cd] in the older tissue whereas the highest [Cd] was found in the youngest (negative exponential growth) as shown in Figure 21. As well as Co and Zn, Cd plays a role as a cofactor in the enzyme Carbonic Anhydrase (CA) (Lane and Morel 2000) which converts  $\text{HCO}_3^-$  into  $\text{CO}_2$  that is required for photosynthesis (Badger and Price 1994). Cd is however the least favorable cofactor for CA, but if there is a depletion of Zn and Co, uptake of Cd

might increase. This could explain the high [Cd] in the younger parts of *S. latissima* as this part contains greater amounts of chloroplasts (Valle 2005) indicating more photosynthetic activity. If the photosynthetic activity in the younger parts is high enough, this might lead to an increase in Cd uptake, hence the higher values shown in the results.

In addition to Cd's role in CA activity, there might be some unknown chemical reactions in the younger parts of the plant that require Cd or are more sensitive or dependent on Cd. We know that the first 10-15cm (meristem) of *S. latissima* are mainly dedicated to growth and not photosynthesis (Sjøtun 1985), hence a totally different cell structure is required. It is at least clear that the younger parts of *S. latissima* have a completely different biological structure and metabolism from the older parts of the same plant. Studies done on trace metal accumulation in macro algae show that the fastest growing parts of the lamina (youngest tissue) accumulate less Cd than the slower growing parts (oldest tissue and stipe) (Markham et al. 1980) which does not agree with the findings in this thesis.

The standard deviations of all elements (except [Zn] and [Cd]) increased as age of tissue increased (see Figure 19, 20 and 21). This indicates greater cell-structural function and heterogeneity within the older tissue than the younger tissue. Since the opposite was shown for [Cd] with a lower standard deviation in the older tissue, it is more reasonable to assume that the standard deviations will increase with increased [element] indicating a great variation amongst the cells in the same age zone where some cells accumulate more than others. This is consistent with the founding of Valle (2005) where cell variation is seen even within the same tissue age.

## 4.8. FOR FUTURE STUDIES

This thesis provides reference data for [elements] in many macro algal species from the littoral zone in the year 2013 and can hopefully be helpful to future studies. This is also, to my knowledge, the first study on trace metal and REE concentrations in macro algae using a proper clean technique to avoid metal contamination. Below are however some advisory comments.

For a better understanding of the metal absorption and adsorption of macro algae it could be wise to also measure the [element] in the surrounding water. It is then possible to consider a potential pollution in the water and also say something about the species ability to accumulate higher or lower concentrations of various elements than the surrounding water. This could also be linked to a better understanding of the macro algal metabolism, which to date are very poor. If HR-ICP-MS is used, a measurement of the sugar content should also be done. This can eliminate the dilution effect of the element in the dry weight-to-element weight ratio and the zonation depth trend found in this study can be seen more clearly. Since the variation estimate in this study showed a greater variance within the replicates than within the individuals, a future study should focus on the number of replicates. More replicates should be sampled although it is important to keep in mind that the different parts of the algae have a very different cell structure. To get an annually time series, the [element] and composition should be measured during more seasons (monthly).

In this study, only two Chlorophytes and one Rhodophyte were sampled. To be able to do valid statistical tests on these two algal classes, more species and more individuals need to be sampled. However, this study indicates that Rhodo-, Chloro- and Phaeophytes are too different to be statistically compared to each other on a species level, hence they need to be analyzed separately if species difference is the main focus.

For a future age study on macro algae the age zones should be sampled with a similar interval to strengthen the trend line. This will make it easier to sample a more comparable age zone between individuals and might also decrease the effect of the macro algal size, as some algae are big and some are small.

My hope is that the information provided in this study will be useful for future studies to gain a deeper knowledge and a better understanding of the macro algal community.

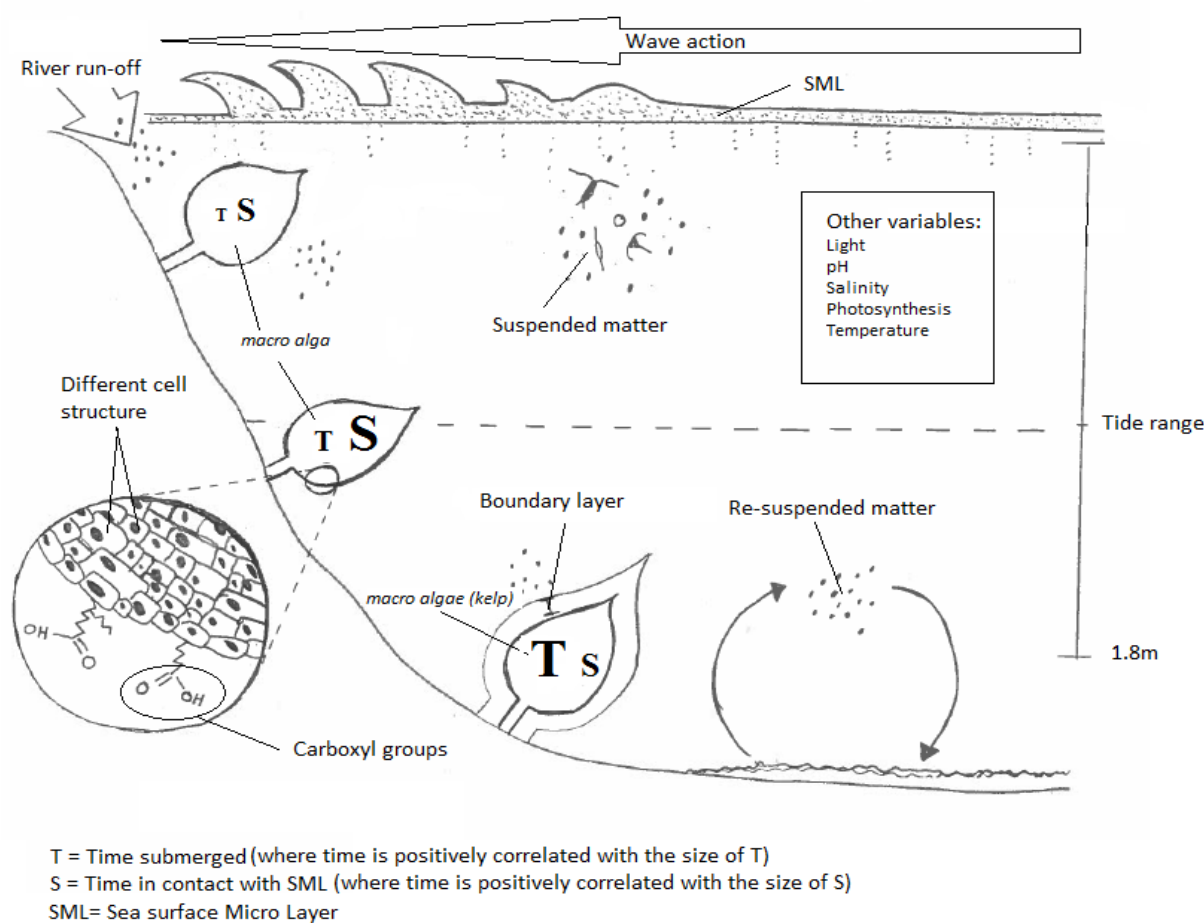
## 5. CONCLUSION

The aim of this study was to check if element composition and concentration in macro algae depend on species, season and age (*S. latissima*). There was a significant difference in [element] and composition between the Phaeophyte species and also between the two seasons (February and May) for the Phaeophytes and a zonation depth trend was also discovered. *Ascophyllum nodosum* deviated from this zonation depth trend for [Fe], [Mn], [Pb], [Ni] and [Cd] which is most likely explained by the high sugar content in this species tissue, hence the elements were diluted in the dry-weight measurements. Another possible reason for this is a decreased passive adsorption for the above mentioned elements in *A. nodosum*. The higher [element] in February is most likely due to depletion of the nutrients in seawater in May by phytoplankton as these probably adsorb micronutrients as well as macronutrients.

We have seen that both environmental and biological factors play an important role in the [element] in macro algae. It seems like the SML has the greatest influence on [element] in algal tissue due to the observation of the zonation depth trend but also that biological factors interfere with the SML contact for some elements, especially with respect to *A. nodosum*. Environmental factors (boundary layer, submersion time and SML) seem to be the dominant cause of variation for [Cu], [Zn], [Co], [Ce], [Tb] and [Yb] and the biological factors (sugar content and cell structure) seem to be the dominant cause of variation for [Fe], [Mn], [Pb], [Ni] and [Cd].

There was also a significant difference in [element] with respect to age in *S. latissima* where there was an exponential increase in [Yb], [Ce], [Tb], [Fe], [Mn], [Zn], [Ni], [Cu], [Co] and [Pb] with tissue age indicating accumulation of elements over time. The [Cd] with respect to tissue age had an exponential decrease with respect to age where the youngest tissue of *S. latissima* had considerably higher [Cd] than the oldest. This is peculiar but one reason for this can be a higher photosynthetic activity in the younger tissue leading to a greater need of cofactors for the enzyme Carbonic Anhydrase (CA). If Zn and Co are depleted already, the algae might adsorb more Cd to be able to continue the high photosynthetic rate.

Another aim for this study was to look at differences between the three algal classes (Phaeo-, Chloro- and Rhodophytes). The highest concentrations of REE were found within the Chlorophyte class and the smallest concentration within the Phaeophytes. Both Rhodo- and Chlorophytes contained higher [element] than the Phaeophytes, with the only exception of Cd and Zn in Chlorophytes. There were great differences between the three algal classes, and it seems that Chloro- and Rhodophytes are better trace metals and REE accumulators than Phaeophytes. Therefore it seems wise to study the species difference of these classes separately as they might not be statistically comparable.



**Figure 22:** Possible scenario for macro algae element uptake in the tidal zone indicating the most important physical, biological and chemical variables that affect the [element] algal tissue. (Kleiven 2014).

Figure 22 shows a simplified macro algal ecosystem where various biological, chemical and physical factors affect the [element] in the algal tissue. The macro algae in the littoral zone live in a dynamic system where various factors interact and determine the macro algal structure and function. Based on the results it is absolutely possible to use macro algae as bio indicators.



## 6. REFERENCES

- Abdelwahed W, Degobert G, Stainmesse S, Fessi H (2006) Freeze-drying on nanoparticles: formulation, process and storage considerations. *Adv Drug Delivery Rev* 58:1688-1713
- Andersen GS, Christie H, Fredriksen S, Moy FE (2011) Seasonal Patterns of Sporophyte Growth, Fertility, Fouling, and Mortality of *Saccharina latissima* in Skagerrak, Norway: Implications of Forest Recovery. *J Mar Biol* :1-8
- Badger MR, Price GD (1994) The role of carbonic anhydrase in photosynthesis. *Annu Rev Plant Biol* 45:369-392
- Bakken J (2000) In: Sakshaug E, Sneli JA (eds.) Trondheimsfjorden. Tapir Academic Press, pp12-18
- Bertin G, Averbeck D (2006) Cadmium: cellular effects, modifications of biomolecules, modulation of DNA repair and genotoxic consequences (a review). *Biochimie*, 88:1549-1559.
- Black WAP (1948) The seasonal variation in chemical composition of some of the littoral seaweeds common to Scotland. Part 1. *Ascophyllum nodosum*. *J Soc Chem Ind* 67:355-357. doi:10.1002/jctb.5000670905
- Black WAP (1954) Seasonal variation in the combined L-fucose content of the common British Laminariaceae and Fucaceae. *J Sci Food Agric* 5:445-448. doi: 10.1002/jsfa.2740050909
- Blossom N (2007) Copper in the Ocean Environment. Am Chemet Corp pp1-6
- Brand LE, Sunda WG, Guillard RR (1986) Reproduction of marine phytoplankton reproduction rates by copper and cadmium. *J Exp Mar Biol Ecol* 96:225-250
- Breitbarth E, Archtberg Ep, Ardelan MV, Baker AR, Bucciarelli E, Chever F, Croot PL, Duggen PL, Gledhill M, Hasselhøv M (2010) Iron biochemistry across marine systems- progress from the past decade. *Biogeoscience* 7:1075-1097
- Bruland KW (1983) Trace elements in sea-water. *Chem Oceanogr* 8:157-219.
- Bryan G (1969) The absorption of zinc and other metals by brown seaweed *Laminaria digitata*. *J Mar Boil Ass UK* 49:225-243
- Burger J, Gochfield M, Jeitner C, Gray M, Shukla T, Shukla S, Burge S (2007). Kelp as a bioindicator: does it matter which part of 5 m long plant is used for metal analysis? *Environ Monit Assess* 128:311-321.

- Carignan V, Villard MA (2002) Selecting indicator species to monitor ecological integrity: a review. *Environ Monit Assess* 78:45-61.
- Castor SB, Hedrick JB (2006) Rare earth elements. In: Kogel JE, Trivedi NC, Barker JM, Krukowski ST (eds) *Industrial minerals and rocks- commodities, markets and uses*, 7th edn. Society for Mining, Metallurgy and Exploration, Littleton, Colorado, USA, pp 827-840
- Croot PL, Bowie AR, Frew RD, Maldonado MT, Hall JA, Safi KA, La Roche J, Boyd PW, Law CS (2001) Retention of dissolved iron and Fe II in an iron induced Southern Ocean phytoplankton bloom. *Geophys Res Lett* 28:3425-3428.
- De Baar HJW (1983) The marine geochemistry of the rare earth elements. Massachusetts Institute of Technology, PhD Thesis, Cambridge MA, USA. 283p
- Dunlap CE, Steinnes E, Flegal AR (1999) A synthesis of lead isotopes in two millennia of European air. *Earth Planet Sci Lett* 167:81-88
- Eisma D (1981) Supply and Deposition of Suspended Matter in the North Sea. *Spec publs int Ass Sediment* 5:415-428. doi:10.1002/9781444303759.ch29
- Evans CH (1983) Interesting and useful biochemical properties of lanthanides. *Trends Biochem Sci* 8:445-449.
- Foster P (1976) Concentrations and concentration factors of heavy metals in brown algae. *Environ Pollut* 10:45-53
- Fourest E, Volesky B (1995) Contribution of sulfonate groups and alginate to heavy metal biosorption by dry biomass of *Sargassum fluitans*. *Environ Sci Technol* 30:277-282
- Frausto da Silva JJ, Williams RJR (2001) *The biological chemistry of the elements*. Oxford University press inc, Oxford, New York, 553p
- Fuge R, James K (1973) Trace metal concentration in brown seaweeds. *Mar Chem* 1:281-293
- Førstner U (1982) Accumulative phases of heavy metals in limnic sediments. *Hydrobiologia* 91:269-284. doi:10.1007/BF2391944
- Gutknecht (1965) Uptake and retention of calcium 137 and zinc 65 by seaweeds. *Limnol Oceanogr* 10:58-66
- Hamdy A (2000) Biosorption of heavy metals by marine algae. *Curr Microbiol* 41:232-238.
- Hardy JT (1982) The sea-surface microlayer: Biology, chemistry and anthropogenic enrichment. *Oceanogr* 11:307-328
- Hardy JT, Crecelius E (1981) Is atmospheric particulate matter inhibiting primary productivity? *Environ Sci Technol* pp 1103-1105

- Holan Z, Volesky B (1994) Biosorption of lead and nickel by biomass of marine algae. *Biotechnol Bioeng* 43:1001-1009
- Holan Z, Volesky B, Prasetyo I (1993) Biosorption of cadmium by biomass of marine algae. *Biotechnol Bioeng* 41:819-825
- Hunter KA (1997) Chemistry of the sea-surface microlayer. In: Liss PS, Duce RA (eds.) *The Sea Surface and Global Change*. Cambridge University Press pp 287-320
- Jensen A, Larsen B, Indegaard M (2000) In: Sakshaug E, Sneli JA (eds.) *Trondheimsfjorden*. Tapir Academic Press, pp 157-168
- Karez C, Magalhaes V, Pfeiffer W, Amadofhilo G (1994) Trace metal accumulation by algae in Septibia Bay, *Environ Pollut* 83:351-356
- Kartikaidevi G, Manivannan K, Thirumaran G, Balasubramanian T, Anantharaman P (2010) Mineral Composition of Marine Macroalgae from Mandapam Coastal Regions; Southeast Coast of India. *Resent Res Sci Technol* 2:66-71
- Landing WM, Bruland KW (1987) The contrasting biogeochemistry of iron and manganese in the Pacific Ocean. *Geochim Cosmochim AC* 51:29-43
- Lane TW, Morel FM (2000) A biological function for cadmium in marine diatoms. *Proc Natl Acad Sci USA* 97:4627-4631
- Lee YC, Chang SP (2011) The biosorption of heavy metals from aqueous solution by *Spirogyra* and *Cladophora* filamentous macroalgae. *Bioresource technol* 102:5297-5304
- Lüning K (1990) *Seaweeds. Their environment, Biogeography and Ecophysiology*. Yarish C, Kirkman H (trans.) Wiley, New York, 527p.
- Lund L (2014) Morphological diversity in *Lamnaria digitata* – different species or differences in phenotype. Marine Biology MSc, Norwegian University of Science and Technology, Trondheim, Norway
- Manahan SE (2010) Oxidation-Reduction in Aquatic Chemistry. In: Manahan (ed.) *Environmental chemistry* 9th edn. CRC Press, Boca Raton, Fla pp84-102
- Markham JW, Kremer BP, Sperling KR (1980) Effect of cadmium on *Laminaria saccharina* in culture. *Marine Ecol Prog Ser* 3:31-39
- Markovac J, Goldsstein GW (1988) Picomolar concentrations of lead stimulate brain protein kinase C. *Nat Commun* 334:71-73
- Martin JH (1990) Glacial-interglacial CO<sub>2</sub> change: The iron hypothesis. *Paleoceanography* 5:1-13

- Martone PT (2007) kelp versus corraline: cellular basis for mechanical strength in the wave-swept seaweed *Calliarthon* (Corallinaceae, Rhodophyta). *J Physiol* 43:882-891
- Mathieson AC, Shipman JW, O'shea JR, Hasevlat RC (1976) Seasonal growth and reproduction of estuarine fucoid algae in New England. *J exp mar biol ecol* 25:273-284
- May TW, Wiedemeyer RH (1998) A table of polyatomic interference in ICP-MS. *At Spectrosc* 19:150-155
- Morel FM (1995) Cadmium: A nutrient for the marine diatom *Thalassiosira weissflogii*. *Limnol Oceanogr* 40:1056-1063
- Morel F, Price N (2003) The biochemical cycles of trace metals in the oceans. *AAAS* 300:944-947
- Moseley JD, Lenden P, Lockwood M, Ruda K, Sherlock JP, Thomson AD, Gilday JP (2008) A comparison of Commercial Microwave Reactors for Scale-Up within Process Chemistry. *Org Process Res Dev* 12:30-40. doi: 10.1021/op700186z
- Myklestad S (1986) Ion-exchange properties of brown algae: Determination of rate mechanism for calciumhydrogen ion exchange for particles from *Laminaria hyperborean* and *Laminaria digitata*. *J Appl Chem* 18:30-36. doi: 10.1002/jctb.5010180107
- Needleman H (2004) Lead Poisoning. *Annu Rev Med* 55:209-222. doi: 10.1146/annurev.med.55.091902.103653
- Oceanor (2003) Høvringen renseannlegg og miljøtilstanden i Trondheimsfjorden (The Høvringen treatment plant and the environmental condition in the Trondheimsfjord). Oceanor, Trondheim, Norway
- Panagiotopoulos A, Perlepes SP, Bakalbassis EG, Terzis A, Raptopoulou CP (2010) Modelling the use of lanthanides (III) as probes at calcium (II) binding sites in biological systems: Preparation and characterization of neodymium (III) and calcium (II) malonato (-1) complexes. *Polyhedron* 29:2465-2472
- Pedersen MF, Nejrup LB, Fredriksen S, Christie H, Norderhaug KM (2012) Effects of wave exposure on population structure, demography, biomass and productivity of the kelp *Laminaria hyperborea*. *Mar Ecol Prog Ser* 451:45-60
- Percival E, McDowell RH (1967) Chemistry and enzymology of marine algal polysaccharides. Academic press, London, UK pp 10-12
- Prospero JM, Ginoux P, Torres O, Nicholson SE, Gill TE (2002) Environmental characterization of global atmospheric soil dust identified with Nimbus 7 Total Ozone Mapping Spectromter (TOMS) absorbing aerosol product. *Rev Geophysiol* 40:1002

- Ragan MA, Smidsrød O, Larsen B (1979) Chelation of divalent metal ions by brown algal polyphenols. *Mar Chem* 7:265-271
- Rao CR (1971) Estimation of variance and covariance components MINQUE theory. *J Multivar Anal* 1:257-275
- Rueness J (1998) *Alger i farger: en felthåndbok om kystens makroalger*. Almater forlag, Oslo, 136p. In Norwegian
- Rueness J (1977) *Norsk Algeflora*, Universitetsforlaget, Tromsø, Norway, 265p. In Norwegian
- Ryan S, McLoughlin P, O'Donovan O (2012) a Comprehensive study of metal distribution in three main classes of seaweed. *Environ Poll* 167:171-177
- Salaün S, Barre S, Santos-Goncalvez M, Potin P, Haras D, Bazire A (2012) Influence of Exudates of the Kelp *Laminaria Digitata* on Biofilm Formation of Associated and Exogenous Bacterial Epiphytes. *Microbial Ecol* 64:359-369. doi:10.1007/s00248-012-0048-4
- Sand-Jensen K (1977) effect of epiphytes on eelgrass photosynthesis. *Aquat Bot* 3:55-63
- Saunders M, Metaxas A (2007) Temperature explains settlement patterns of the introduced bryozoan *Membranipora membranacea* in Nova Scotia Canada. *Mar Ecol Prog Ser* 344:95-10
- Sawidis T, Brown M, Zachariadis G, Sratis I (2001) Trace metal concentration in marine macroalgae from different biotopes in the Aegean Sea. *Environ Int* 27:103-111
- Sciewver S, Volesky B (2000) Biosorption by marine algae. In: James JV (ed.) *Bioremediation*. Springer Netherlands pp139-169
- Seed R, Harris S (1980) The epifauna of the fronds of *Laminaria digitata* Lamour in Strangford Lough, Northern Ireland. *Proc R Irish Acad* 80:91-106
- Sholkovitz ER (1995) The aquatic chemistry of rare earth elements in rivers and estuaries. *Aquat Geochem* 1:1-34
- Shvartsburg AA, Jarrold MF (1996) An exact hard-spheres scattering model for the mobilities of polyatomic ions. *Chem Phys Lett* 261:86-91
- Sjøtun K (1985) Ei autøkologisk undersøkning av *Laminaria saccharina* (L.) Lamour i Espegrend-området. Cand Real Thesis, University of Bergen, 211p, In Norwegian
- Sjøtun K (1995) Adaptive aspects of growth and reproduction in to North Atlantic *Laminaria* species. Ph.D. thesis, University of Bergen

- 
- Skoog DA, West DM, Holler FJ, Crouch SR (2013) Mass Spectrometry. In: Simpson C, Kiselica S, Landsberg A, Schwartz RB (eds.) Fundamentals of analytical chemistry. 9<sup>th</sup> edn, Cengage Learning, Belmont, USA, pp802-817
- Stengel DB, Macken A, Morrison L, Morley N (2004) Zinc concentration in marine macroalgae and a lichen from western Ireland in relation to phylogenetic grouping, habitat and morphology. *Mar Pollut Bull* 48:902-909
- Sunda WG, Huntsman SA (1995) Iron uptake and growth limitation in oceanic and coastal phytoplankton. *Mar Chem* 50:189-206
- Taylor HE (2001) Instrumentation. In: Taylor HE (ed.) Inductive coupled plasma-mass spectrometry: practices and techniques. Academic Press, San Diego pp29-51
- Tessier A, Campbell P (1987) Partitioning of trace metals in sediments: relationship with bioavailability. *Hydrobiologia* 149:43-52
- Valle KC (2005) Detection of monthly variation in marine red, brown and green macroalgae by means of in situ video, epifluorescence microscopy and numerical digital image analysis. MSc, Norwegian University of Science and Technology, 119p
- Wheeler W (1980) Effect of boundary layer transport on the fixation of carbon by the giant kelp *Macrocystis pyrifera*. *Mar Biol* 56:103-110
- Xu Y, Shi D, Aristilde L, Morel FM (2012) The effect of pH on the uptake of zinc and cadmium in marine phytoplankton: Possible role of weak complexes. *Limnol Oceanogr* 57:293-304. doi:10.4319/lo.2012.57.1.0000

---

## WEB SITES

1. Element database, periodic table (2013) © ElementsDatabase.com  
<<http://www.elementsdatabase.com/>>. Accessed 05 April 2014
2. Google Maps, <<https://www.google.no/maps/preview/place/Br nnebukta/@63.4478719,10.3278957,11371m/data=!3m1!1e3!4m2!3m1!1s0x466d33b453d19503:0xaa20ee a97db4ec48>>. Accessed 12.03.2014
3. Vannstand.no, Kartverket,  
<<http://vannstand.no/index.php/tidevannsdatabell>>. Accessed 02 May 2014
4. Cook C (2002) Vacuum Freeze-drying Archaeological Artifacts - CCI Notes 4/2, Canada conservation institute, last updated 2007,  Minister of Public Works and Government Services, Canada, <<http://www.cci-icc.gc.ca/publications/notes/4-2-eng.aspx>>. Accessed 26 May 2014
5. Wolf RE (2005) What is ICP-MS... and more importantly, what can it do? USGS, Crustal Geophysics and Geochemistry Science Center, USA, last updated 2013, <<http://crustal.usgs.gov/laboratories/icpms/intro.html>>. Accessed 28 May 2014

## APPENDIX 1

## Multifactorial ANOVA and LSD tables

**Table 3.** Multifactorial ANOVA table with Iron (Fe) as the dependent variable and three fixed factors (Species, Season and Individual)

Source	Sum of Squares	Df	Mean Square	F-Ratio	P-Value
MAIN EFFECTS					
A:Species	73796,4	5	14759,3	77,47	<b>0,0000</b>
B:Season	2525,9	1	2525,9	13,26	<b>0,0004</b>
C:IndNo	301,624	2	150,812	0,79	0,4560
RESIDUAL	18860,9	99	190,514		
TOTAL (CORRECTED)	95484,8	107			

All F-ratios are based on the residual mean square error.

**Table 4.** Multiple range test for Fe (LSD) with the homogeneous species shown to the right.

Species	Count	LS Mean	LS Sigma	Homogeneous Groups
<i>L. digitata</i>	18	18,85	3,25332	X
<i>A. nodosum</i>	18	27,1889	3,25332	XX
<i>P. canaliculata</i>	18	29,2722	3,25332	X
<i>F. spiralis</i>	18	40,3444	3,25332	X
<i>F. vesiculosus</i>	18	66,25	3,25332	X
<i>F. serratus</i>	18	93,8222	3,25332	X

**Table 5.** Multifactorial ANOVA table with Copper (Cu) as the dependent variable and three fixed factors (Species, Season and Individual)

Source	Sum of Squares	Df	Mean Square	F-Ratio	P-Value
MAIN EFFECTS					
A:Species	219,806	5	43,9613	31,05	<b>0,0000</b>
B:Season	65,0381	1	65,0381	45,94	<b>0,0000</b>
C:IndNo	2,68201	2	1,341	0,95	0,3913
RESIDUAL	140,163	99	1,41579		
TOTAL (CORRECTED)	427,689	107			

All F-ratios are based on the residual mean square error.

**Table 6.** Multiple range test for Cu (LSD) with the homogeneous species shown to the right.

Species	Count	LS Mean	LS Sigma	Homogeneous Groups
<i>P. canaliculata</i>	18	1,29833	0,280455	X
<i>L. digitata</i>	18	2,42444	0,280455	X
<i>F. spiralis</i>	18	2,475	0,280455	X
<i>F. vesiculosus</i>	18	4,08333	0,280455	X
<i>F. serratus</i>	18	5,00056	0,280455	X
<i>A. nodosum</i>	18	5,12	0,280455	X



**Table 7.** Multifactorial ANOVA table with Cadmium (Cd) as the dependent variable and three fixed factors (Species, Season and Individual)

<i>Source</i>	<i>Sum of Squares</i>	<i>Df</i>	<i>Mean Square</i>	<i>F-Ratio</i>	<i>P-Value</i>
MAIN EFFECTS					
A:Species	71,8197	5	14,3639	174,38	<b>0,0000</b>
B:Season	1,338	1	1,338	16,24	<b>0,0001</b>
C:IndNo	0,0803836	2	0,0401918	0,49	0,6154
RESIDUAL	8,15473	99	0,082371		
TOTAL (CORRECTED)	81,3928	107			

All F-ratios are based on the residual mean square error.

**Table 8.** Multiple range test for Cd (LSD) with the homogeneous species shown to the right.

<i>Species</i>	<i>Count</i>	<i>LS Mean</i>	<i>LS Sigma</i>	<i>Homogeneous Groups</i>
<i>L. digitata</i>	18	0,127278	0,0676474	X
<i>P. canaliculata</i>	18	0,205667	0,0676474	X
<i>A. nodosum</i>	18	0,205833	0,0676474	X
<i>F. spiralis</i>	18	0,552667	0,0676474	X
<i>F. vesiculosus</i>	18	1,168	0,0676474	X
<i>F. serratus</i>	18	2,42383	0,0676474	X

**Table 9.** Multifactorial ANOVA table with Cobalt (Co) as the dependent variable and three fixed factors (Species, Season and Individual)

<i>Source</i>	<i>Sum of Squares</i>	<i>Df</i>	<i>Mean Square</i>	<i>F-Ratio</i>	<i>P-Value</i>
MAIN EFFECTS					
A:Species	82,3523	5	16,4705	98,99	<b>0,0000</b>
B:Season	1,9144	1	1,9144	11,51	<b>0,0010</b>
C:IndNo	0,255555	2	0,127777	0,77	0,4667
RESIDUAL	16,4714	99	0,166378		
TOTAL (CORRECTED)	100,994	107			

All F-ratios are based on the residual mean square error.

**Table 10.** Multiple range test for Co (LSD) with the homogeneous species shown to the right.

<i>Species</i>	<i>Count</i>	<i>LS Mean</i>	<i>LS Sigma</i>	<i>Homogeneous Groups</i>
<i>L. digitata</i>	18	0,0417778	0,0961416	X
<i>P. canaliculata</i>	18	0,165222	0,0961416	X
<i>F. spiralis</i>	18	0,533667	0,0961416	X
<i>F. vesiculosus</i>	18	0,899389	0,0961416	X
<i>A. nodosum</i>	18	0,942722	0,0961416	X
<i>F. serratus</i>	18	2,67928	0,0961416	X

**Table 11.** Multifactorial ANOVA table with Manganese (Mn) as the dependent variable and three fixed factors (Species, Season and Individual)

<i>Source</i>	<i>Sum of Squares</i>	<i>Df</i>	<i>Mean Square</i>	<i>F-Ratio</i>	<i>P-Value</i>
MAIN EFFECTS					
A:Species	202062,	5	40412,4	117,55	<b>0,0000</b>
B:Season	5820,77	1	5820,77	16,93	<b>0,0001</b>
C:IndNo	66,0292	2	33,0146	0,10	0,9085
RESIDUAL	34034,7	99	343,785		
TOTAL (CORRECTED)	241984,	107			

All F-ratios are based on the residual mean square error.

**Table 12.** Multiple range test for Mn (LSD) with the homogeneous species shown to the right.

<i>Species</i>	<i>Count</i>	<i>LS Mean</i>	<i>LS Sigma</i>	<i>Homogeneous Groups</i>
<i>L. digitata</i>	18	2,63722	4,37026	X
<i>P. canaliculata</i>	18	5,82222	4,37026	X
<i>A. nodosum</i>	18	10,8033	4,37026	X
<i>F. spiralis</i>	18	28,5383	4,37026	X
<i>F. vesiculosus</i>	18	80,6722	4,37026	X
<i>F. serratus</i>	18	117,652	4,37026	X

**Table 13.** Multifactorial ANOVA table with Nickel (Ni) as the dependent variable and three fixed factors (Species, Season and Individual)

<i>Source</i>	<i>Sum of Squares</i>	<i>Df</i>	<i>Mean Square</i>	<i>F-Ratio</i>	<i>P-Value</i>
MAIN EFFECTS					
A:Species	737,77	5	147,554	46,54	<b>0,0000</b>
B:Season	38,2228	1	38,2228	12,06	<b>0,0008</b>
C:IndNo	5,50611	2	2,75306	0,87	0,4228
RESIDUAL	313,854	99	3,17024		
TOTAL (CORRECTED)	1095,35	107			

All F-ratios are based on the residual mean square error.

**Table 14.** Multiple range test for Ni (LSD) with the homogeneous species shown to the right.

<i>Species</i>	<i>Count</i>	<i>LS Mean</i>	<i>LS Sigma</i>	<i>Homogeneous Groups</i>
<i>L. digitata</i>	18	0,168889	0,419672	X
<i>P. canaliculata</i>	18	0,793333	0,419672	X
<i>A. nodosum</i>	18	1,99056	0,419672	X
<i>F. vesiculosus</i>	18	4,11278	0,419672	X
<i>F. spiralis</i>	18	4,28	0,419672	X
<i>F. serratus</i>	18	7,94833	0,419672	X

**Table 15.** Multifactorial ANOVA table with Zink (Zn) as the dependent variable and three fixed factors (Species, Season and Individual)

Source	Sum of Squares	Df	Mean Square	F-Ratio	P-Value
MAIN EFFECTS					
A:Species	162669,	5	32533,8	68,14	<b>0,0000</b>
B:Season	12717,7	1	12717,7	26,64	<b>0,0000</b>
C:IndNo	936,878	2	468,439	0,98	0,3785
RESIDUAL	47267,1	99	477,446		
TOTAL (CORRECTED)	223591,	107			

All F-ratios are based on the residual mean square error.

**Table 16.** Multiple range test for Zn (LSD) with the homogeneous species shown to the right.

Species	Count	LS Mean	LS Sigma	Homogeneous Groups
<i>P.canaliculata</i>	18	16,3783	5,15022	X
<i>L. digitata</i>	18	32,4789	5,15022	X
<i>F. spiralis</i>	18	45,5261	5,15022	X
<i>F. vesiculosus</i>	18	72,4267	5,15022	X
<i>A. nodosum</i>	18	96,8883	5,15022	X
<i>F. serratus</i>	18	129,544	5,15022	X

**Table 17.** Multifactorial ANOVA table with Lead (Pb) as the dependent variable and three fixed factors (Species, Season and Individual)

Source	Sum of Squares	Df	Mean Square	F-Ratio	P-Value
MAIN EFFECTS					
A:Species	0,12955	5	0,0259101	62,53	<b>0,0000</b>
B:Season	0,0117605	1	0,0117605	28,38	<b>0,0000</b>
C:IndNo	0,00229163	2	0,00114581	2,77	0,0678
RESIDUAL	0,0410242	99	0,000414386		
TOTAL (CORRECTED)	0,184627	107			

All F-ratios are based on the residual mean square error.

**Table 18.** Multiple range test for Pb (LSD) with the homogeneous species shown to the right.

Species	Count	LS Mean	LS Sigma	Homogeneous Groups
<i>A. nodosum</i>	18	0,0259444	0,00479807	X
<i>P.canaliculata</i>	18	0,0292778	0,00479807	X
<i>L. digitata</i>	18	0,0325	0,00479807	X
<i>F. spiralis</i>	18	0,0508333	0,00479807	X
<i>F. vesiculosus</i>	18	0,0614444	0,00479807	X
<i>F. serratus</i>	18	0,126611	0,00479807	X

**Table 19.** Multifactorial ANOVA table with Cerium (Ce) as the dependent variable and three fixed factors (Species, Season and Individual)

Source	Sum of Squares	Df	Mean Square	F-Ratio	P-Value
MAIN EFFECTS					
A:Species	0,137831	5	0,0275661	24,47	<b>0,0000</b>
B:Season	0,00292448	1	0,00292448	2,60	0,1103
C:IndNo	0,000489556	2	0,000244778	0,22	0,8050
RESIDUAL	0,111504	99	0,00112631		
TOTAL (CORRECTED)	0,252749	107			

All F-ratios are based on the residual mean square error.

**Table 20.** Multiple range test for Ce (LSD) with the homogeneous species shown to the right.

Species	Count	LS Mean	LS Sigma	Homogeneous Groups
<i>P.canaliculata</i>	18	0,0286667	0,00791029	X
<i>F. spiralis</i>	18	0,0537778	0,00791029	X
<i>A. nodosum</i>	18	0,0595556	0,00791029	XX
<i>L. digitata</i>	18	0,0772222	0,00791029	X
<i>F. vesiculosus</i>	18	0,0816667	0,00791029	X
<i>F. serratus</i>	18	0,144111	0,00791029	X

**Table 21.** Multifactorial ANOVA table with Terbium (Tb) as the dependent variable and three fixed factors (Species, Season and Individual)

Source	Sum of Squares	Df	Mean Square	F-Ratio	P-Value
MAIN EFFECTS					
A:Species	0,000130337	5	0,0000260674	23,57	<b>0,0000</b>
B:Season	0,0000137245	1	0,0000137245	12,41	<b>0,0006</b>
C:IndNo	2,56852E-7	2	1,28426E-7	0,12	0,8905
RESIDUAL	0,000109496	99	0,00000110602		
TOTAL (CORRECTED)	0,000253814	107			

All F-ratios are based on the residual mean square error.

**Table 22.** Multiple range test for Tb (LSD) with the homogeneous species shown to the right.

Species	Count	LS Mean	LS Sigma	Homogeneous Groups
<i>L. digitata</i>	18	0,000594444	0,000247882	X
<i>P.canaliculata</i>	18	0,000811111	0,000247882	X
<i>F. vesiculosus</i>	18	0,00168889	0,000247882	X
<i>F. spiralis</i>	18	0,00202222	0,000247882	X
<i>A. nodosum</i>	18	0,00298333	0,000247882	X
<i>F. serratus</i>	18	0,00367222	0,000247882	X

**Table 23.** Multifactorial ANOVA table with Ytterbium (Yb) as the dependent variable and three fixed factors (Species, Season and Individual)

<i>Source</i>	<i>Sum of Squares</i>	<i>Df</i>	<i>Mean Square</i>	<i>F-Ratio</i>	<i>P-Value</i>
MAIN EFFECTS					
A:Species	0,00153573	5	0,000307146	20,27	<b>0,0000</b>
B:Season	0,000192534	1	0,000192534	12,71	<b>0,0006</b>
C:IndNo	5,69074E-7	2	2,84537E-7	0,02	0,9814
RESIDUAL	0,00149996	99	0,0000151511		
TOTAL (CORRECTED)	0,00322879	107			

All F-ratios are based on the residual mean square error.

**Table 24.** Multiple range test for Yb (LSD) with the homogeneous species shown to the right.

<i>Species</i>	<i>Count</i>	<i>LS Mean</i>	<i>LS Sigma</i>	<i>Homogeneous Groups</i>
<i>L. digitata</i>	18	0,00147778	0,000917458	X
<i>P. canaliculata</i>	18	0,00260556	0,000917458	X
<i>F. vesiculosus</i>	18	0,00546667	0,000917458	X
<i>F. spiralis</i>	18	0,00717778	0,000917458	X
<i>A. nodosum</i>	18	0,0111278	0,000917458	X
<i>F. serratus</i>	18	0,0111889	0,000917458	X

## APPENDIX 2

Multifactorial ANOVA and LSD tables for *Saccharina latissima***Table 25.** Multifactorial ANOVA table with Ytterbium (Yb) as the dependent variable and two fixed factors (age zone in *Saccharina latissima* and Individuals).

Source	Sum of Squares	Df	Mean Square	F-Ratio	P-Value
MAIN EFFECTS					
A:age zone	0,00161363	3	0,000537876	8,73	<b>0,0009</b>
B:Ind	0,000741966	2	0,000370983	6,02	<b>0,0099</b>
RESIDUAL	0,0011084	18	0,0000615775		
TOTAL (CORRECTED)	0,00346399	23			

All F-ratios are based on the residual mean square error.

**Table 26.** Multiple range test for Yb (LSD) with the homogeneous age zones shown to the right.

age zone	Count	LS Mean	LS Sigma	Homogeneous Groups
1	6	0,00336667	0,00320358	X
2	6	0,00551667	0,00320358	X
3	6	0,0099	0,00320358	X
4	6	0,0244	0,00320358	X

**Table 27.** Multifactorial ANOVA table with Iron (Fe) as the dependent variable and two fixed factors (age zone in *Saccharina latissima* and Individuals).

Source	Sum of Squares	Df	Mean Square	F-Ratio	P-Value
MAIN EFFECTS					
A:age zone	1,00938E6	3	336461,	10,53	<b>0,0003</b>
B:Ind	375329,	2	187664,	5,87	<b>0,0109</b>
RESIDUAL	575016,	18	31945,3		
TOTAL (CORRECTED)	1,95973E6	23			

All F-ratios are based on the residual mean square error.

**Table 28.** Multiple range test for Fe (LSD) with the homogeneous age zones shown to the right.

age zone	Count	LS Mean	LS Sigma	Homogeneous Groups
1	6	66,1167	72,9672	X
2	6	110,6	72,9672	X
3	6	221,75	72,9672	X
4	6	587,983	72,9672	X

**Table 29.** Multifactorial ANOVA table with Copper (Cu) as the dependent variable and two fixed factors (age zone in *Saccharina latissima* and Individuals).

Source	Sum of Squares	Df	Mean Square	F-Ratio	P-Value
MAIN EFFECTS					
A:Ind	0,590408	2	0,295204	7,65	<b>0,0039</b>
B:age zone	1,75542	3	0,585139	15,16	<b>0,0000</b>
RESIDUAL	0,694958	18	0,0386088		
TOTAL (CORRECTED)	3,04078	23			

All F-ratios are based on the residual mean square error.

**Table 30.** Multiple range test for Cu (LSD) with the homogeneous age zones shown to the right.

age zone	Count	LS Mean	LS Sigma	Homogeneous Groups
2	6	0,655	0,0802172	X
1	6	0,691667	0,0802172	X
3	6	0,756667	0,0802172	X
4	6	1,32	0,0802172	X

**Table 31.** Multifactorial ANOVA table with Cadmium (Cd) as the dependent variable and two fixed factors (age zone in *Saccharina latissima* and Individuals).

Source	Sum of Squares	Df	Mean Square	F-Ratio	P-Value
MAIN EFFECTS					
A:age zone	1,03769	3	0,345898	32,95	<b>0,0000</b>
B:Ind	0,284852	2	0,142426	13,57	<b>0,0003</b>
RESIDUAL	0,188958	18	0,0104977		
TOTAL (CORRECTED)	1,5115	23			

All F-ratios are based on the residual mean square error.

**Table 32.** Multiple range test for Cd (LSD) with the homogeneous age zones shown to the right.

age zone	Count	LS Mean	LS Sigma	Homogeneous Groups
4	6	0,155	0,0418284	X
3	6	0,197167	0,0418284	X
2	6	0,368667	0,0418284	X
1	6	0,6835	0,0418284	X

**Table 33.** Multifactorial ANOVA table with Cobalt (Co) as the dependent variable and two fixed factors (age zone in *Saccharina latissima* and Individuals).

Source	Sum of Squares	Df	Mean Square	F-Ratio	P-Value
MAIN EFFECTS					
A:age zone	0,208996	3	0,0696655	11,79	<b>0,0002</b>
B:Ind	0,0636403	2	0,0318202	5,38	<b>0,0147</b>
RESIDUAL	0,106386	18	0,00591034		
TOTAL (CORRECTED)	0,379023	23			

All F-ratios are based on the residual mean square error.

**Table 34.** Multiple range test for Co (LSD) with the homogeneous age zones shown to the right.

age zone	Count	LS Mean	LS Sigma	Homogeneous Groups
1	6	0,0638333	0,0313856	X
2	6	0,0795	0,0313856	X
3	6	0,133167	0,0313856	X
4	6	0,299333	0,0313856	X

**Table 35.** Multifactorial ANOVA table with Manganese (Mn) as the dependent variable and two fixed factors (age zone in *Saccharina latissima* and Individuals).

Source	Sum of Squares	Df	Mean Square	F-Ratio	P-Value
MAIN EFFECTS					
A:age zone	494,47	3	164,823	31,86	<b>0,0000</b>
B:Ind	125,175	2	62,5876	12,10	<b>0,0005</b>
RESIDUAL	93,1242	18	5,17357		
TOTAL (CORRECTED)	712,77	23			

All F-ratios are based on the residual mean square error.

**Table 36.** Multiple range test for Mn (LSD) with the homogeneous age zones shown to the right.

age zone	Count	LS Mean	LS Sigma	Homogeneous Groups
1	6	5,125	0,92858	X
2	6	6,57	0,92858	X
3	6	9,46833	0,92858	X
4	6	16,895	0,92858	X



**Table 37.** Multifactorial ANOVA table with Nickel (Ni) as the dependent variable and two fixed factors (age zone in *Saccharina latissima* and Individuals).

Source	Sum of Squares	Df	Mean Square	F-Ratio	P-Value
MAIN EFFECTS					
A:age zone	3,90573	3	1,30191	13,99	<b>0,0001</b>
B:Ind	0,792633	2	0,396317	4,26	<b>0,0306</b>
RESIDUAL	1,67537	18	0,0930759		
TOTAL (CORRECTED)	6,37373	23			

All F-ratios are based on the residual mean square error.

**Table 38.** Multiple range test for Ni (LSD) with the homogeneous age zones shown to the right.

age zone	Count	LS Mean	LS Sigma	Homogeneous Groups
1	6	0,201667	0,12455	X
2	6	0,265	0,12455	X
3	6	0,508333	0,12455	X
4	6	1,21833	0,12455	X

**Table 39.** Multifactorial ANOVA table with Zink (Zn) as the dependent variable and two fixed factors (age zone in *Saccharina latissima* and Individuals).

Source	Sum of Squares	Df	Mean Square	F-Ratio	P-Value
MAIN EFFECTS					
A:age zone	1853,29	3	617,763	235,35	<b>0,0000</b>
B:Ind	130,68	2	65,34	24,89	<b>0,0000</b>
RESIDUAL	47,2483	18	2,62491		
TOTAL (CORRECTED)	2031,22	23			

**Table 40.** Multiple range test for Zn (LSD) with the homogeneous age zones shown to the right.

age zone	Count	LS Mean	LS Sigma	Homogeneous Groups
1	6	16,1667	0,661426	X
2	6	16,4667	0,661426	X
3	6	22,9833	0,661426	X
4	6	37,8333	0,661426	X

**Table 41.** Multifactorial ANOVA table with Lead (Pb) as the dependent variable and two fixed factors (age zone in *Saccharina latissima* and Individuals).

Source	Sum of Squares	Df	Mean Square	F-Ratio	P-Value
MAIN EFFECTS					
A:age zone	0,120403	3	0,0401344	10,93	<b>0,0003</b>
B:Ind	0,0511322	2	0,0255661	6,96	<b>0,0058</b>
RESIDUAL	0,0661092	18	0,00367274		
TOTAL (CORRECTED)	0,237645	23			

All F-ratios are based on the residual mean square error.

**Table 42.** Multiple range test for Pb (LSD) with the homogeneous age zones shown to the right.

age zone	Count	LS Mean	LS Sigma	Homogeneous Groups
1	6	0,0566667	0,0247411	X
2	6	0,065	0,0247411	X
3	6	0,116667	0,0247411	X
4	6	0,234167	0,0247411	X

**Table 43.** Multifactorial ANOVA table with Cerium (Ce) as the dependent variable and two fixed factors (age zone in *Saccharina latissima* and Individuals).

Source	Sum of Squares	Df	Mean Square	F-Ratio	P-Value
MAIN EFFECTS					
A:age zone	8,63933	3	2,87978	97,08	<b>0,0000</b>
B:Ind	1,01232	2	0,50616	17,06	<b>0,0001</b>
RESIDUAL	0,533937	18	0,0296632		
TOTAL (CORRECTED)	10,1856	23			

All F-ratios are based on the residual mean square error.

**Table 44.** Multiple range test for Ce (LSD) with the homogeneous age zones shown to the right.

age zone	Count	LS Mean	LS Sigma	Homogeneous Groups
1	6	0,381667	0,0703126	X
2	6	0,7795	0,0703126	X
3	6	1,0725	0,0703126	X
4	6	2,00917	0,0703126	X

**Table 45.** Multifactorial ANOVA table with Terbium (Tb) as the dependent variable and two fixed factors (age zone in *Saccharina latissima* and Individuals).

Source	Sum of Squares	Df	Mean Square	F-Ratio	P-Value
MAIN EFFECTS					
A:age zone	0,000255458	3	0,0000851526	10,54	<b>0,0003</b>
B:Ind	0,000109511	2	0,0000547554	6,78	<b>0,0064</b>
RESIDUAL	0,000145431	18	0,00000807949		
TOTAL (CORRECTED)	0,0005104	23			

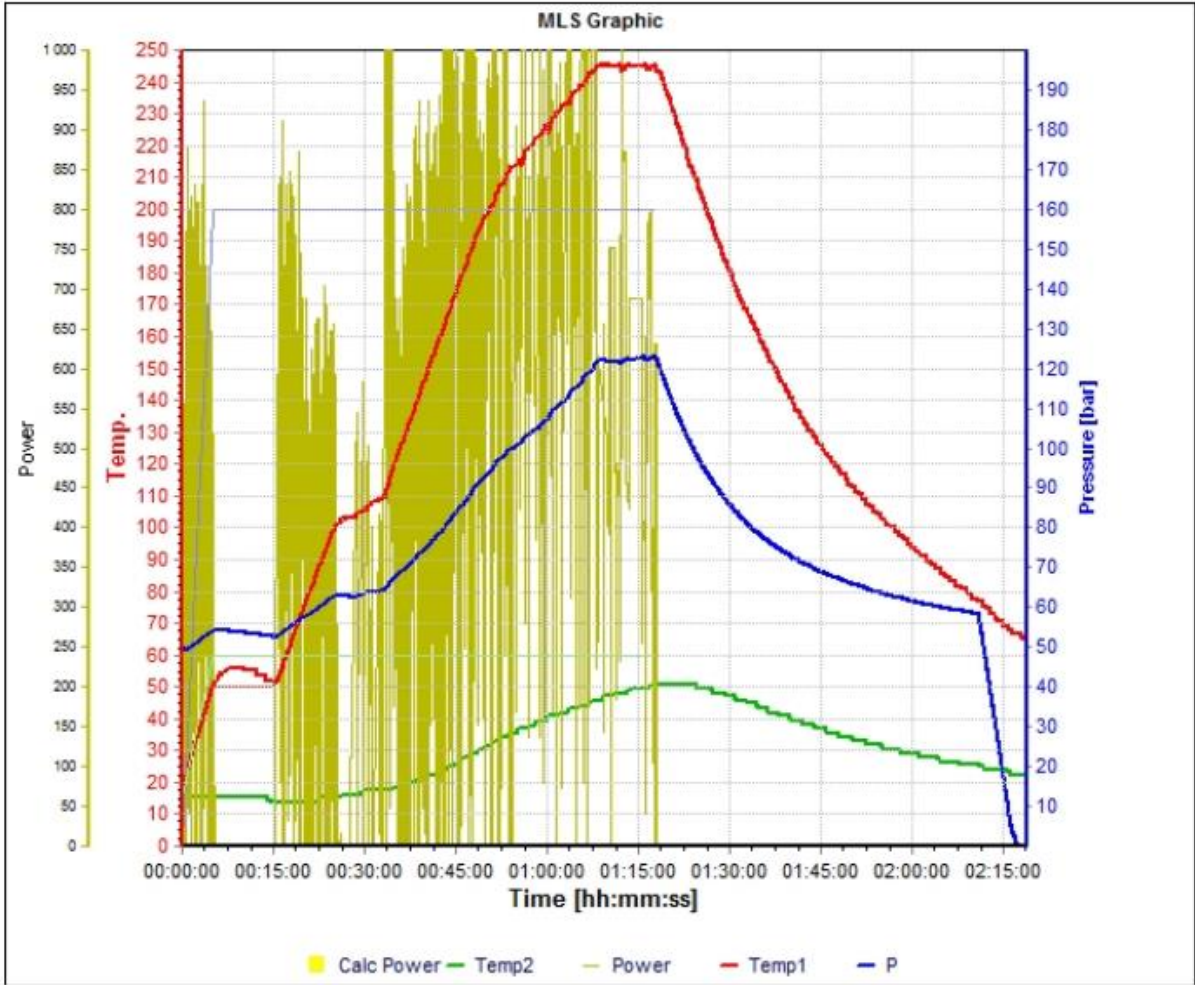
All F-ratios are based on the residual mean square error.

**Table 46.** Multiple range test for Tb (LSD) with the homogeneous age zones shown to the right.

age zone	Count	LS Mean	LS Sigma	Homogeneous Groups
1	6	0,0017	0,00116042	X
2	6	0,00226667	0,00116042	X
3	6	0,00426667	0,00116042	X
4	6	0,00995	0,00116042	X

# APPENDIX 3

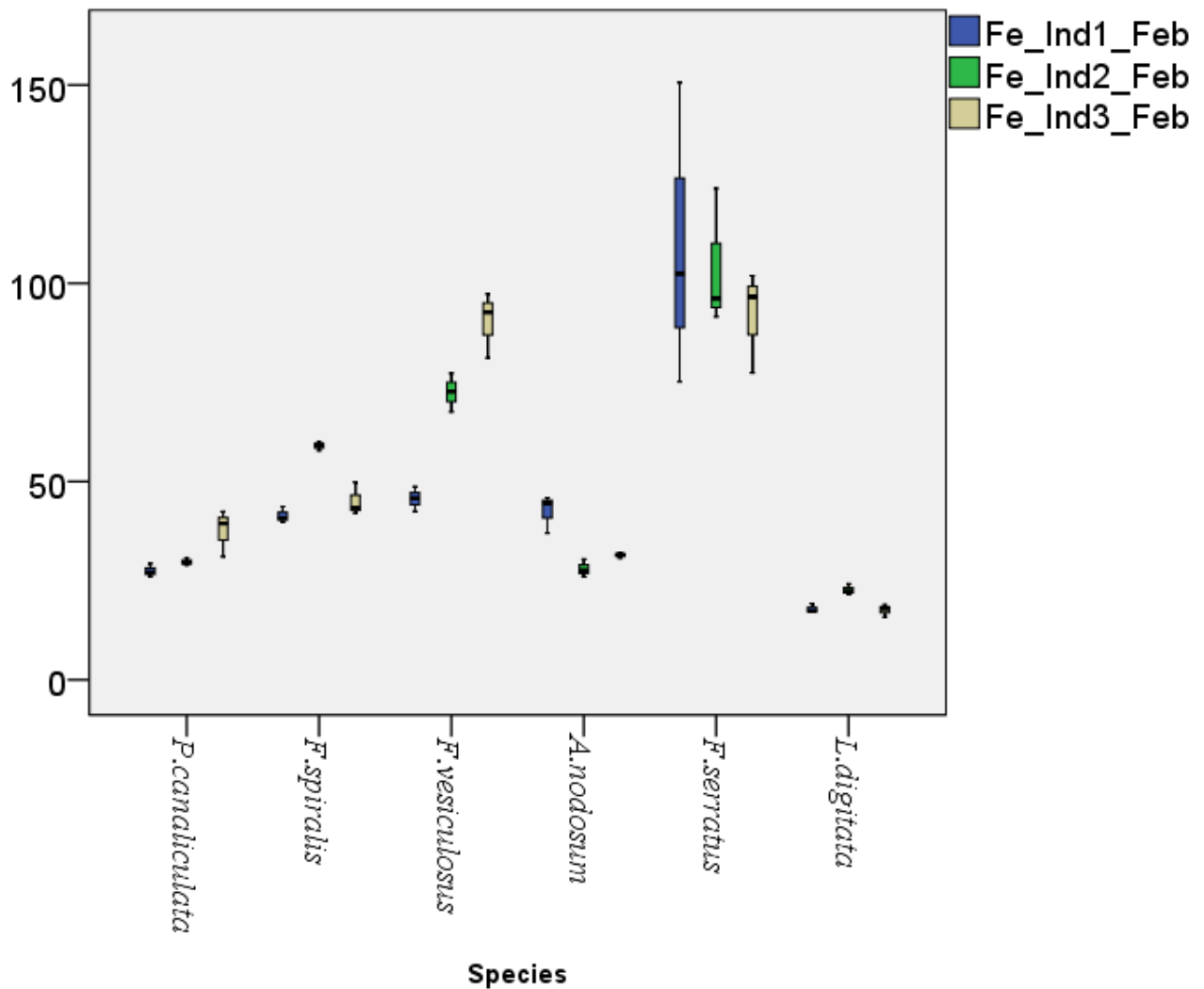
## Ultra Clave report



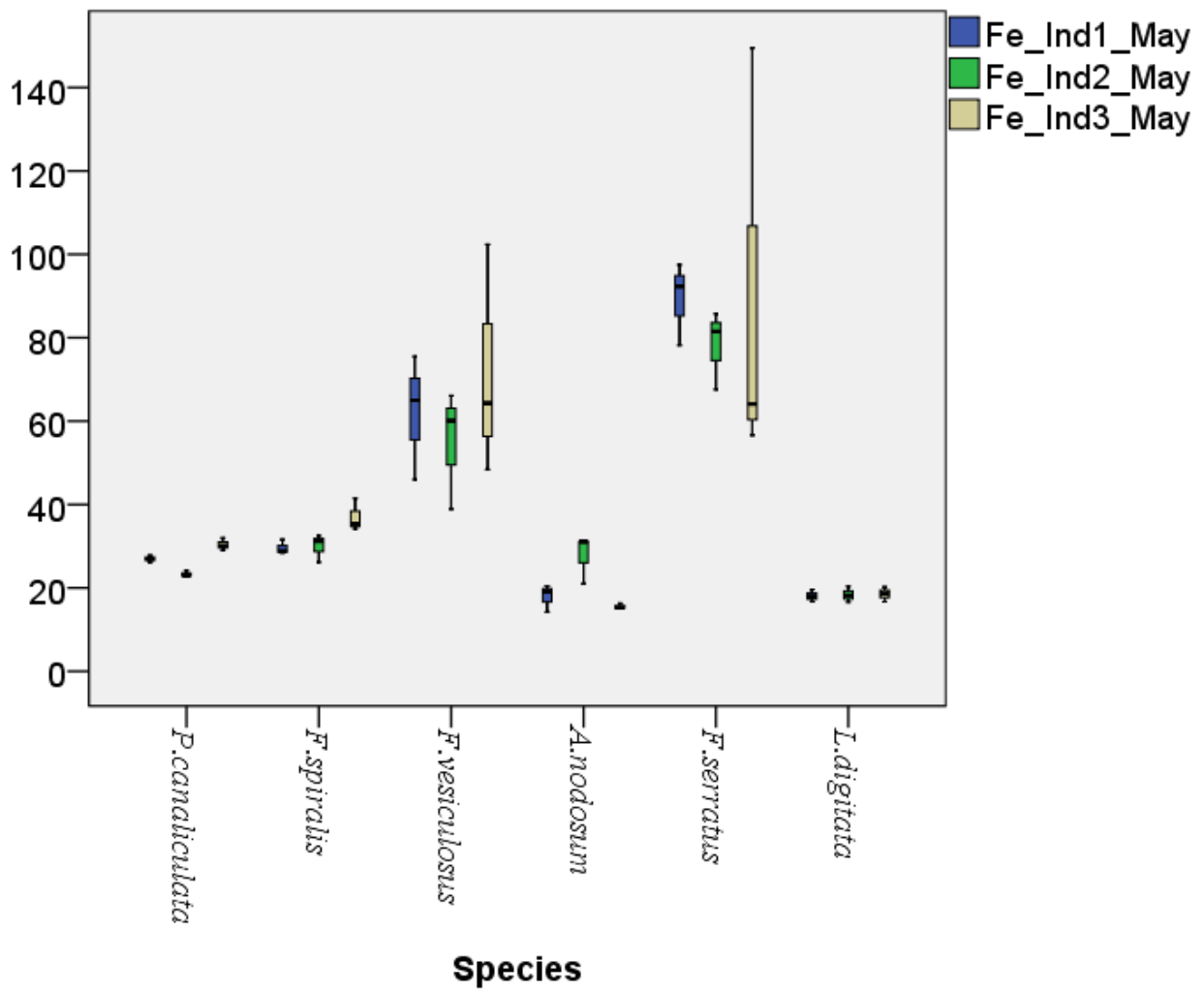
**Figure 23.** A report for the Ultra Clave procedure (14.11.13) where temperature, pressure and time is shown for the decomposition of the samples.

## APPENDIX 4

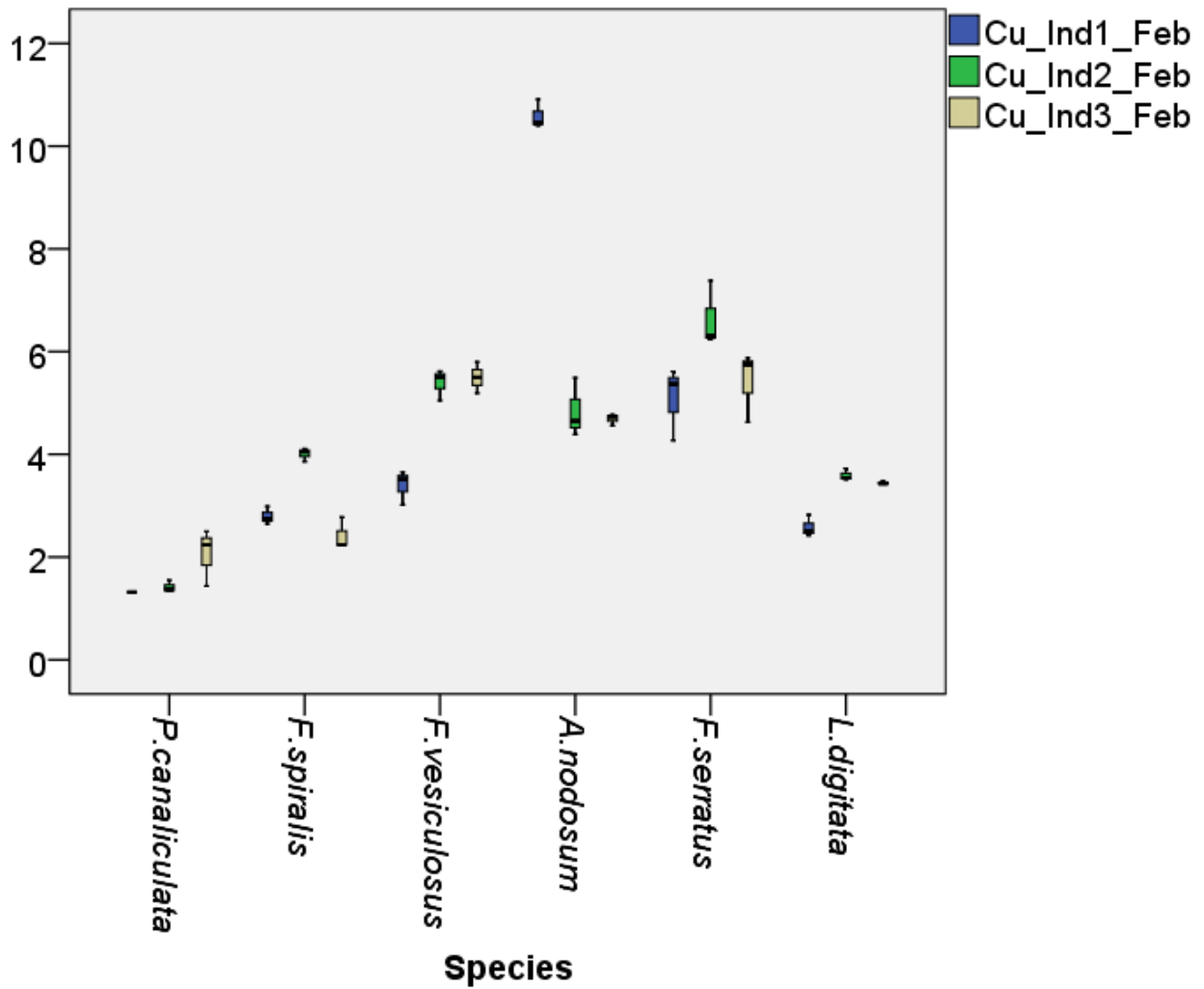
Figures of [element] with individuals separated



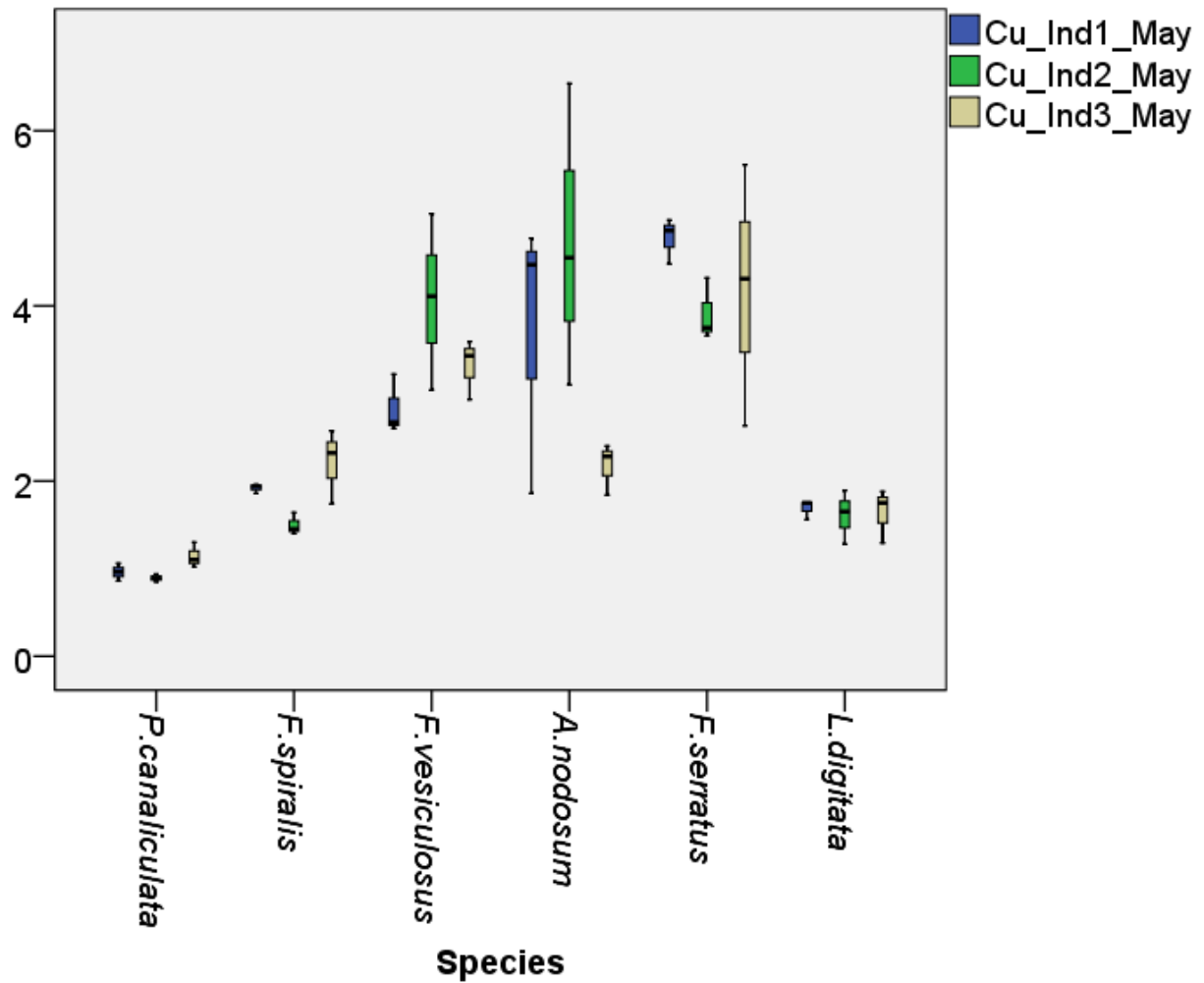
**Figure 24.** Average weight ( $\mu\text{g/g}$ ) of Iron (Fe) in dry algal tissue *Pelvetia canaliculata*, *Fucus spiralis*, *Fucus vesiculosus*, *Ascophyllum nodosum*, *Fucus serratus*, and *Laminaria digitata*, from February 28<sup>th</sup> with specimen 1 (blue), specimen 2 (green) and specimen 3 (grey). The corresponding standard deviation values ( $\pm 2$  SD) are expressed with whiskers on each column.



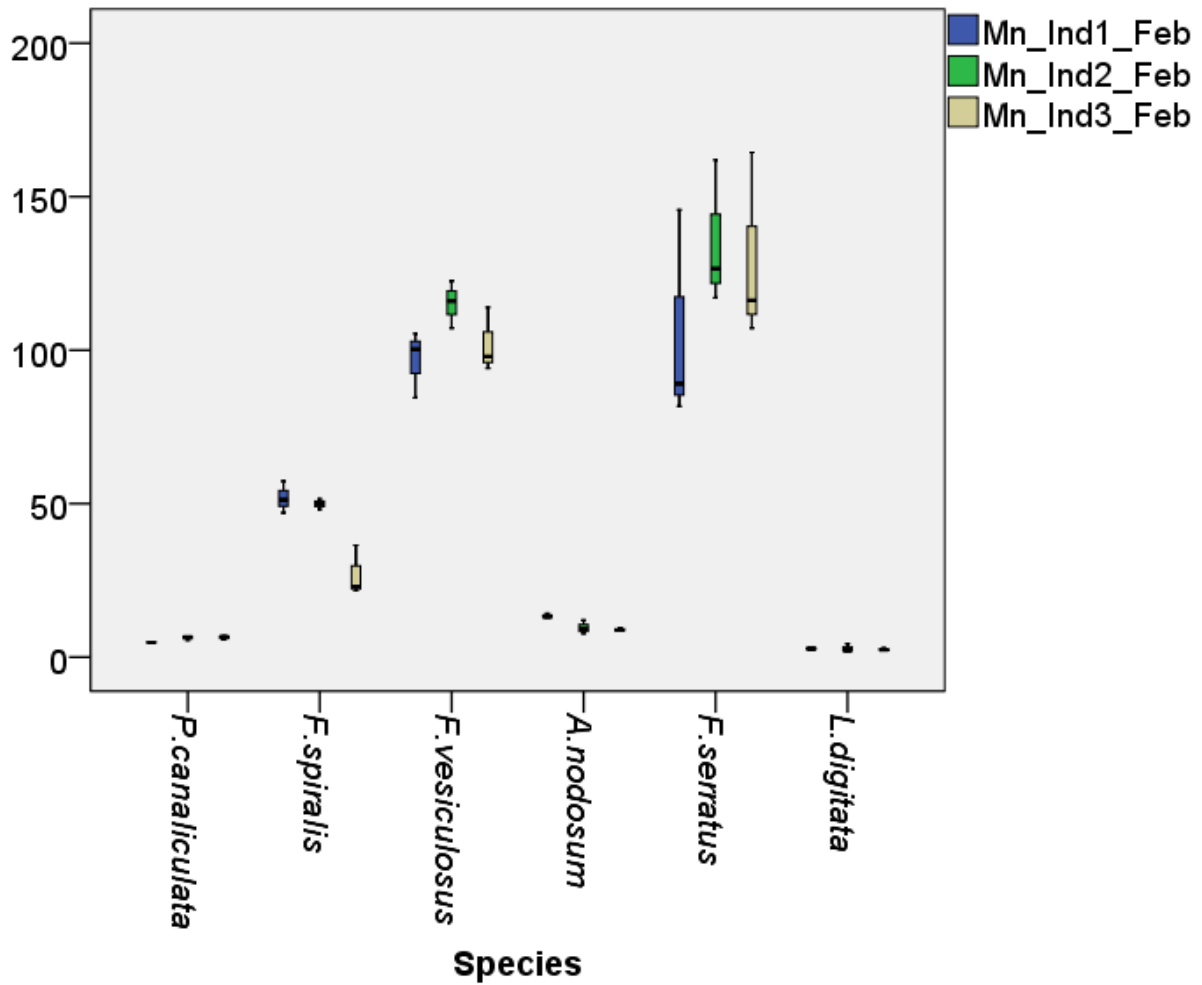
**Figure 25.** Average weight ( $\mu\text{g/g}$ ) of Iron (Fe) in dry algal tissue *Pelvetia canaliculata*, *Fucus spiralis*, *Fucus vesiculosus*, *Ascophyllum nodosum*, *Fucus serratus*, and *Laminaria digitata*, from May 6<sup>th</sup> with specimen 1 (blue), specimen 2 (green) and specimen 3 (grey). The corresponding standard deviation values ( $\pm 2$  SD) are expressed with whiskers on each column.



**Figure 26.** Average weight ( $\mu\text{g/g}$ ) of Copper (Cu) in dry algal tissue *Pelvetia canaliculata*, *Fucus spiralis*, *Fucus vesiculosus*, *Ascophyllum nodosum*, *Fucus serratus*, and *Laminaria digitata*, from February 28<sup>th</sup> with specimen 1 (blue), specimen 2 (green) and specimen 3 (grey). The corresponding standard deviation values ( $\pm 2$  SD) are expressed with whiskers on each column.

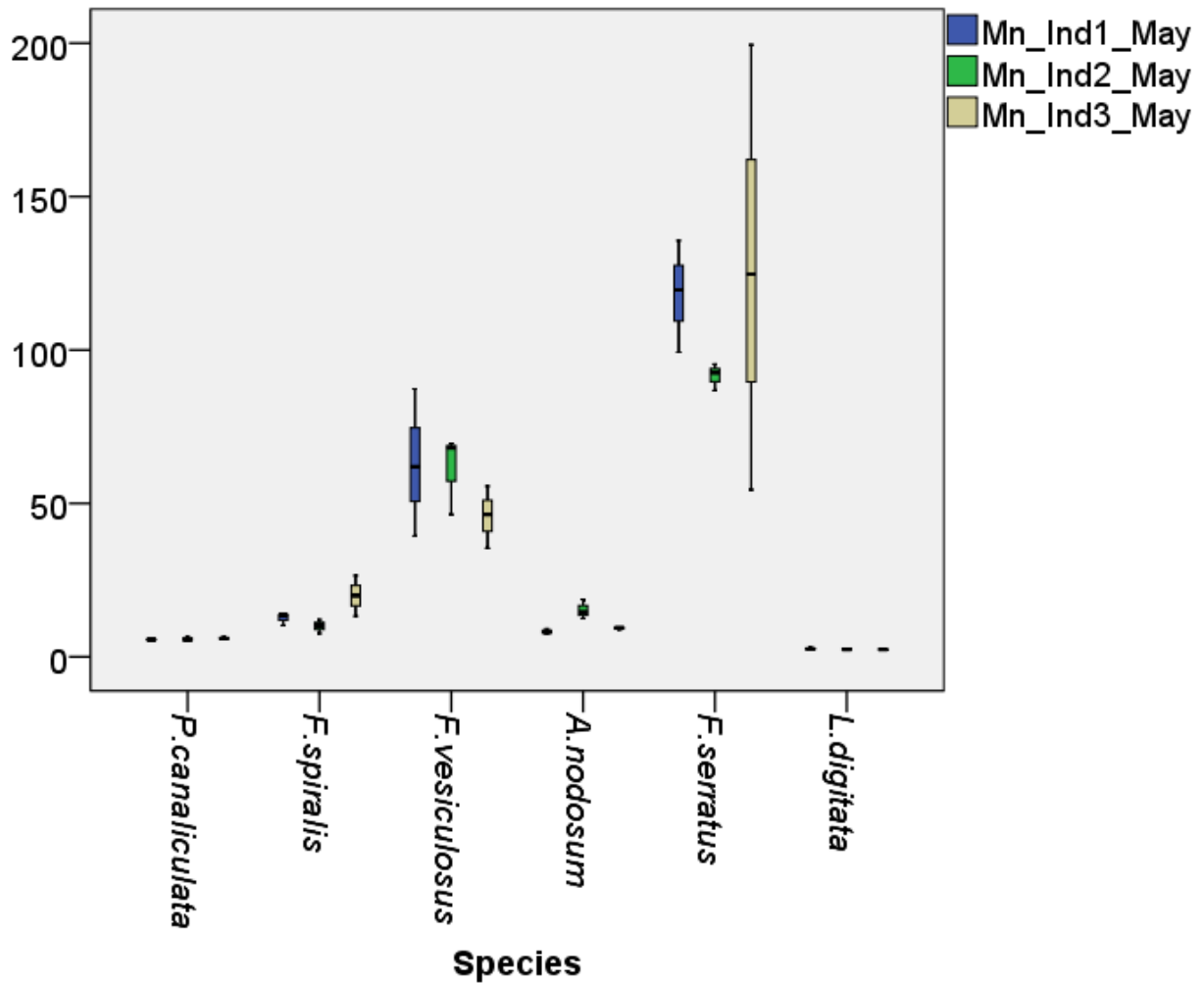


**Figure 27.** Average weight ( $\mu\text{g/g}$ ) of Copper (Cu) in dry algal tissue *Pelvetia canaliculata*, *Fucus spiralis*, *Fucus vesiculosus*, *Ascophyllum nodosum*, *Fucus serratus*, and *Laminaria digitata*, from May 6<sup>th</sup> with specimen 1 (blue), specimen 2 (green) and specimen 3 (grey). The corresponding standard deviation values ( $\pm 2$  SD) are expressed with whiskers on each column.

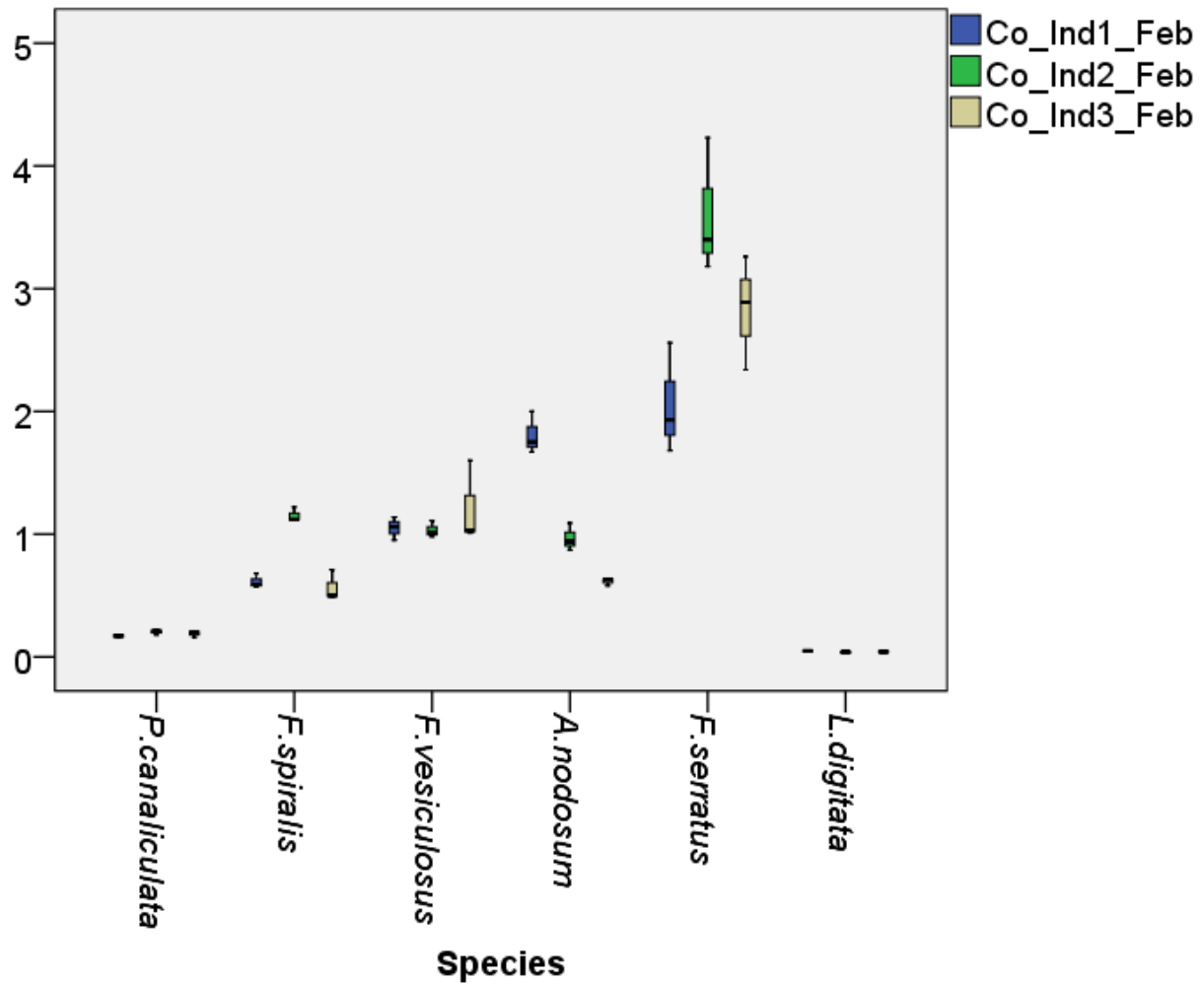


**Figure 28.** Average weight ( $\mu\text{g/g}$ ) of Manganese (Mn) in dry algal tissue *Pelvetia canaliculata*, *Fucus spiralis*, *Fucus vesiculosus*, *Ascophyllum nodosum*, *Fucus serratus*, and *Laminaria digitata*, from February 28<sup>th</sup> with specimen 1 (blue), specimen 2 (green) and specimen 3 (grey). The corresponding standard deviation values ( $\pm 2$  SD) are expressed with whiskers on each column.

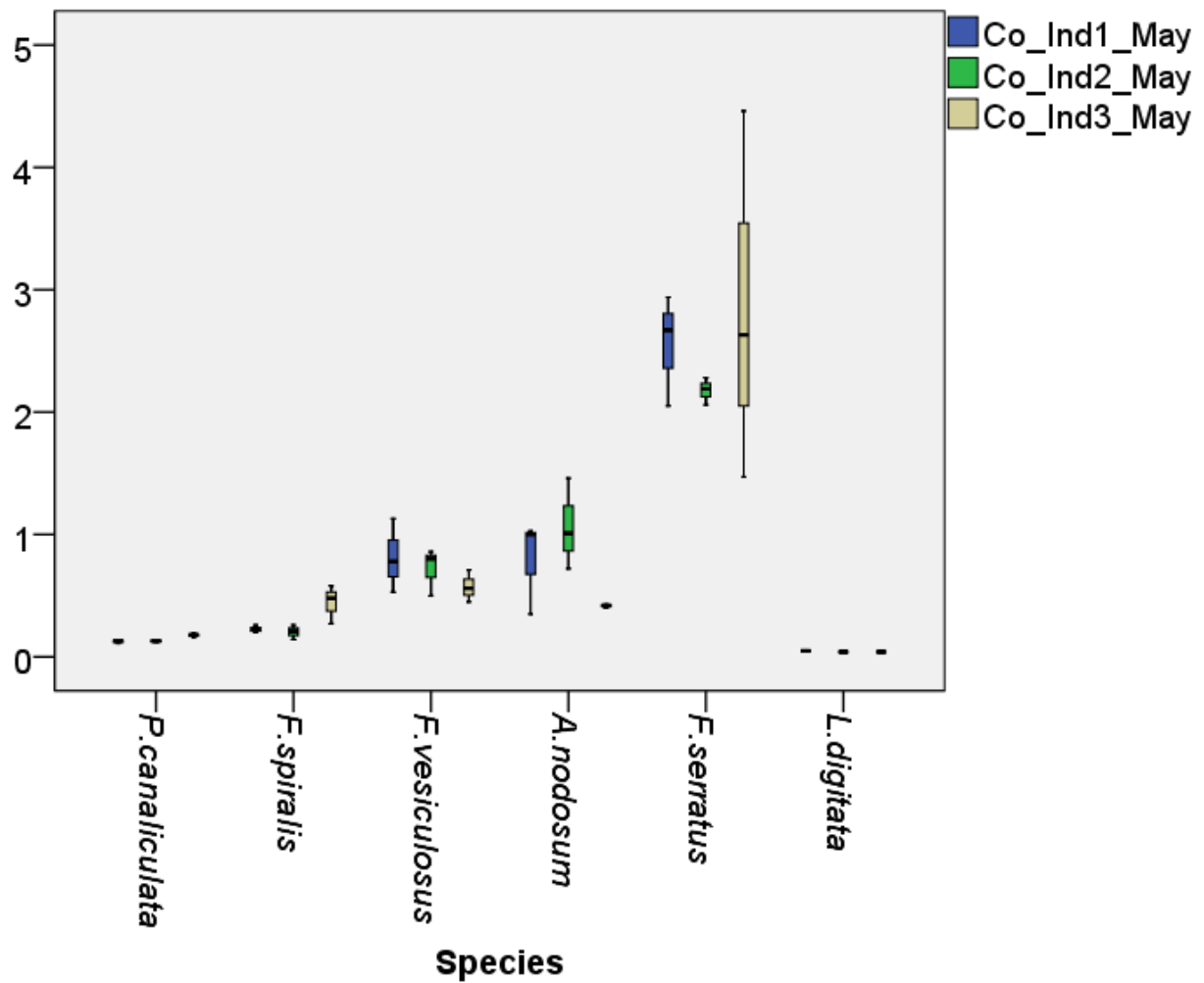




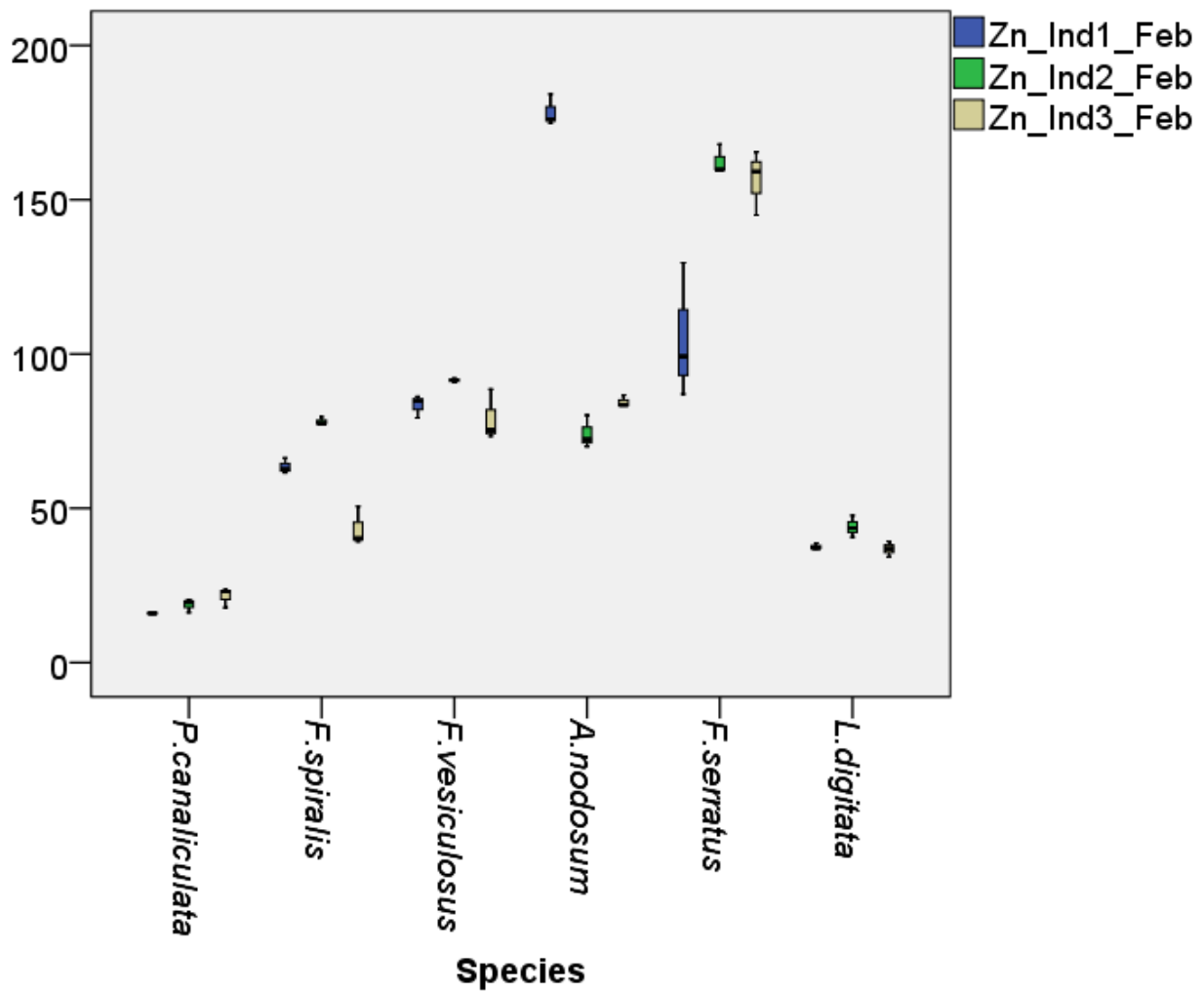
**Figure 29.** Average weight ( $\mu\text{g/g}$ ) of Manganese (Mn) in dry algal tissue *Pelvetia canaliculata*, *Fucus spiralis*, *Fucus vesiculosus*, *Ascophyllum nodosum*, *Fucus serratus*, and *Laminaria digitata*, from May 6<sup>th</sup> with specimen 1 (blue), specimen 2 (green) and specimen 3 (grey). The corresponding standard deviation values ( $\pm 2$  SD) are expressed with whiskers on each column.



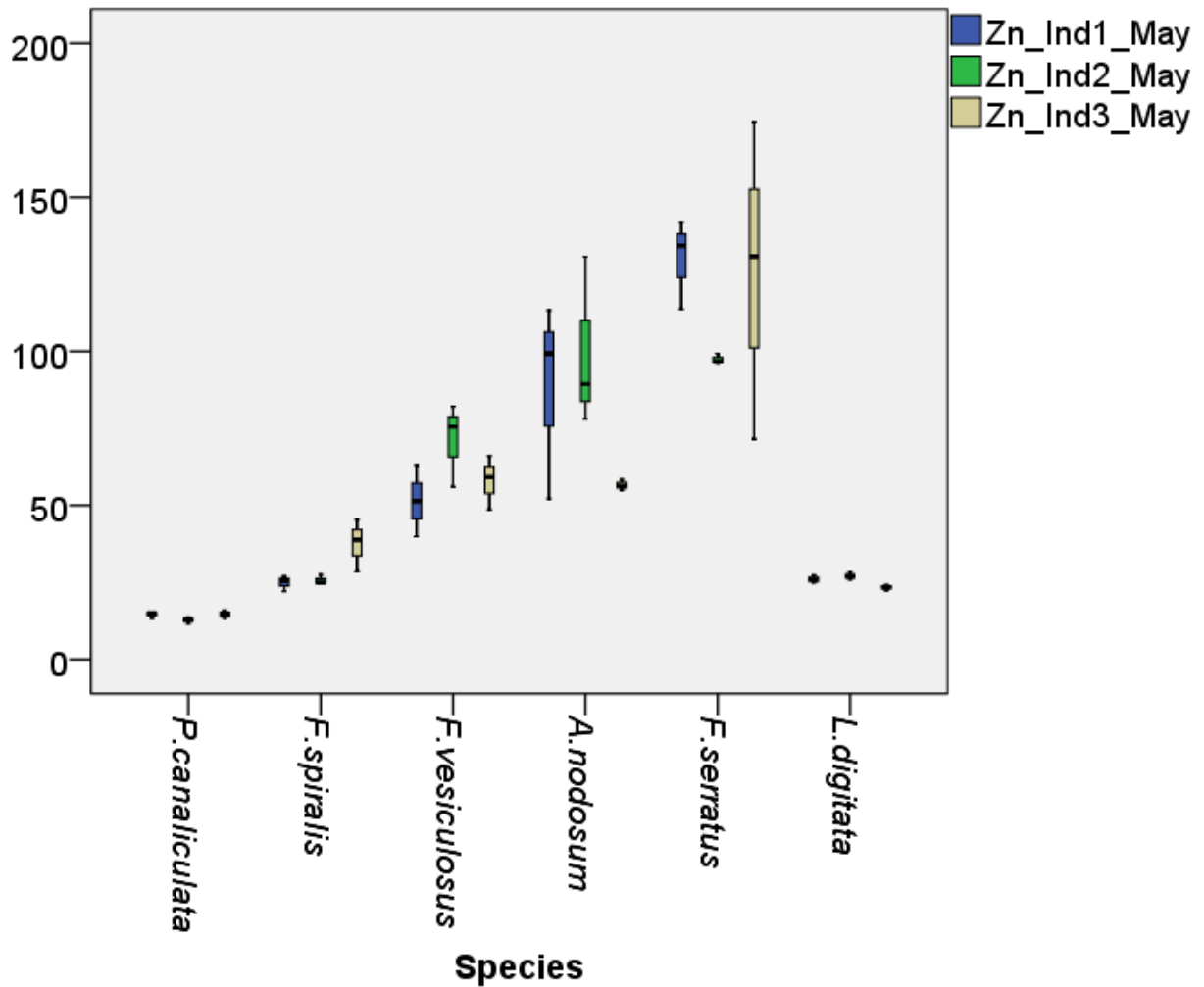
**Figure 30.** Average weight ( $\mu\text{g/g}$ ) of Cobalt (Co) in dry algal tissue *Pelvetia canaliculata*, *Fucus spiralis*, *Fucus vesiculosus*, *Ascophyllum nodosum*, *Fucus serratus*, and *Laminaria digitata*, from February 28<sup>th</sup> with specimen 1 (blue), specimen 2 (green) and specimen 3 (grey). The corresponding standard deviation values ( $\pm 2$  SD) are expressed with whiskers on each column.



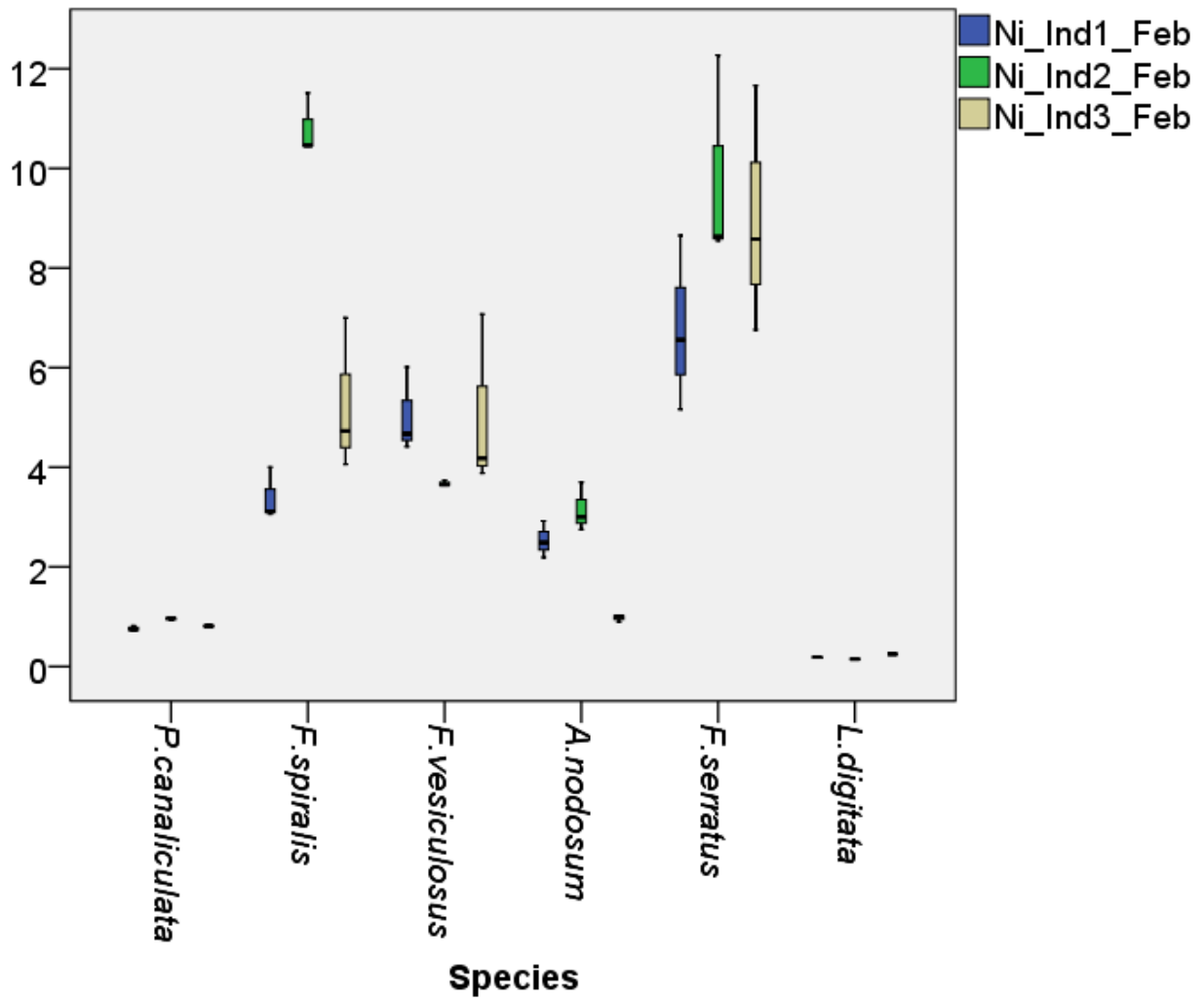
**Figure 31.** Average weight ( $\mu\text{g/g}$ ) of Cobalt (Co) in dry algal tissue *Pelvetia canaliculata*, *Fucus spiralis*, *Fucus vesiculosus*, *Ascophyllum nodosum*, *Fucus serratus*, and *Laminaria digitata*, from May 6<sup>th</sup> with specimen 1 (blue), specimen 2 (green) and specimen 3 (grey). The corresponding standard deviation values ( $\pm 2$  SD) are expressed with whiskers on each column.



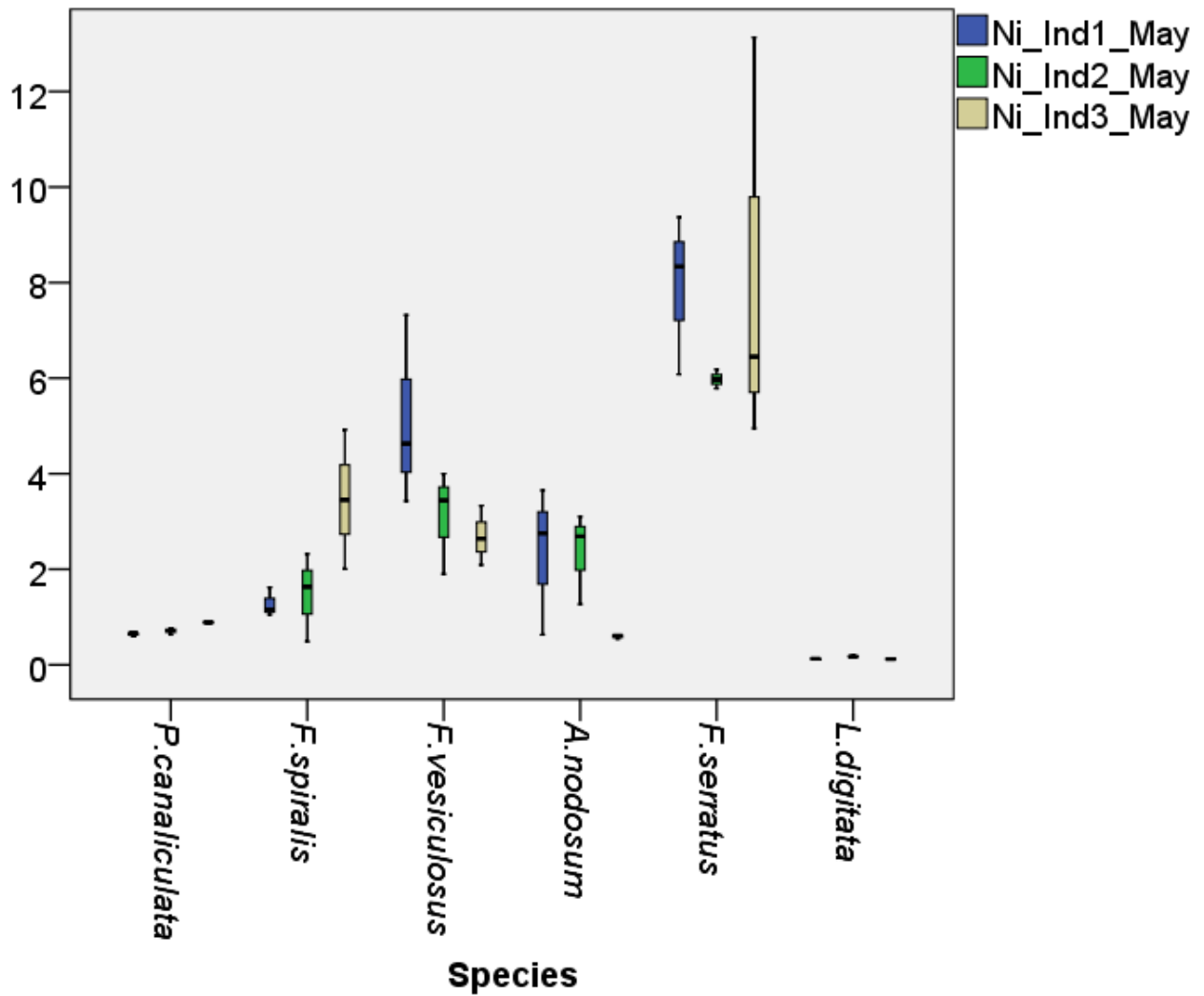
**Figure 32.** Average weight ( $\mu\text{g/g}$ ) of Zink (Zn) in dry algal tissue *Pelvetia canaliculata*, *Fucus spiralis*, *Fucus vesiculosus*, *Ascophyllum nodosum*, *Fucus serratus*, and *Laminaria digitata*, from February 28<sup>th</sup> with specimen 1 (blue), specimen 2 (green) and specimen 3 (grey). The corresponding standard deviation values ( $\pm 2$  SD) are expressed with whiskers on each column.



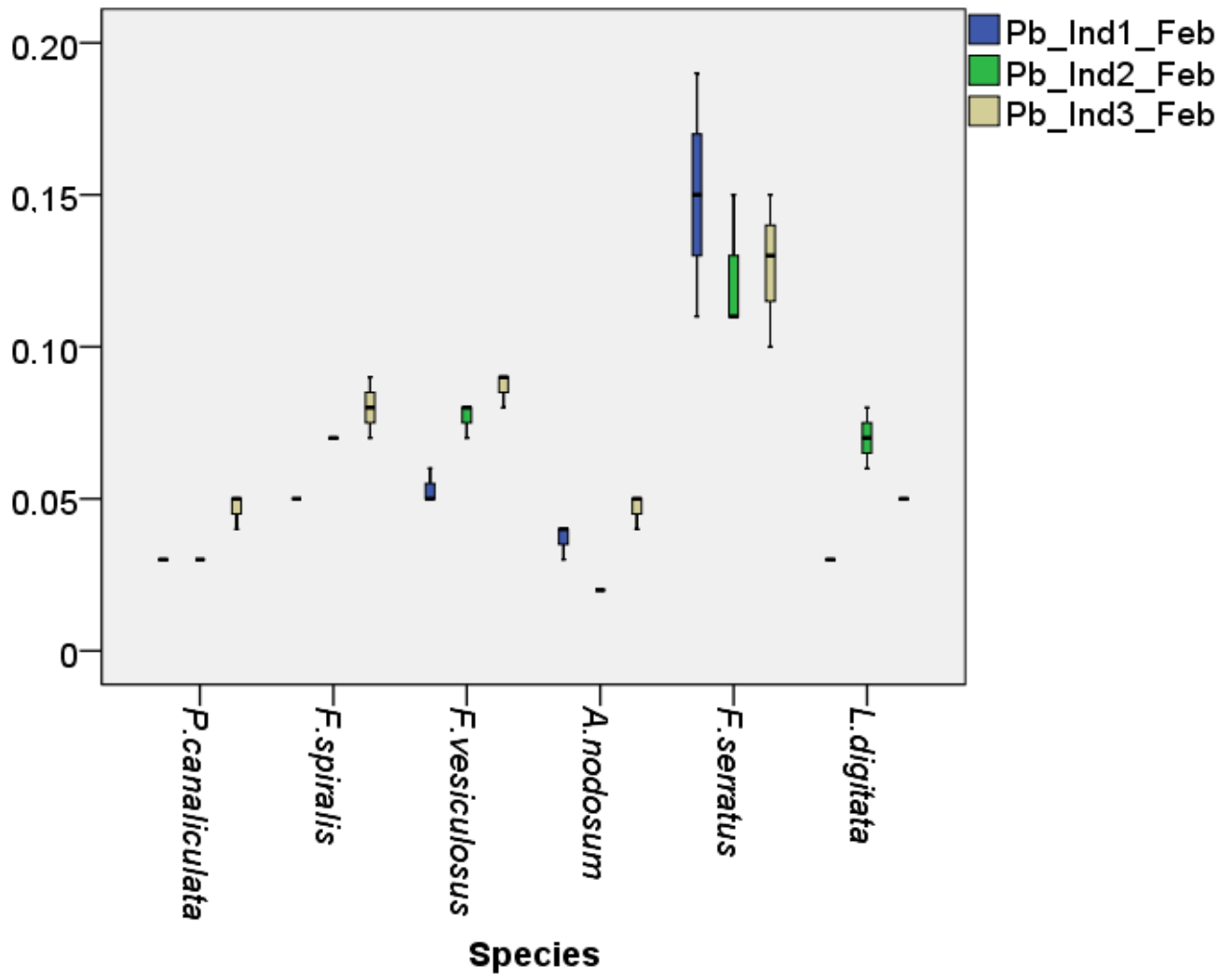
**Figure 33.** Average weight ( $\mu\text{g/g}$ ) of Zink (Zn) in dry algal tissue *Pelvetia canaliculata*, *Fucus spiralis*, *Fucus vesiculosus*, *Ascophyllum nodosum*, *Fucus serratus*, and *Laminaria digitata*, from May 6<sup>th</sup> with specimen 1 (blue), specimen 2 (green) and specimen 3 (grey). The corresponding standard deviation values ( $\pm 2$  SD) are expressed with whiskers on each column.



**Figure 34.** Average weight (µg/g) of Nickel (Ni) in dry algal tissue *Pelvetia canaliculata*, *Fucus spiralis*, *Fucus vesiculosus*, *Ascophyllum nodosum*, *Fucus serratus*, and *Laminaria digitata*, from February 28<sup>th</sup> with specimen 1 (blue), specimen 2 (green) and specimen 3 (grey). The corresponding standard deviation values ( $\pm 2$  SD) are expressed with whiskers on each column.

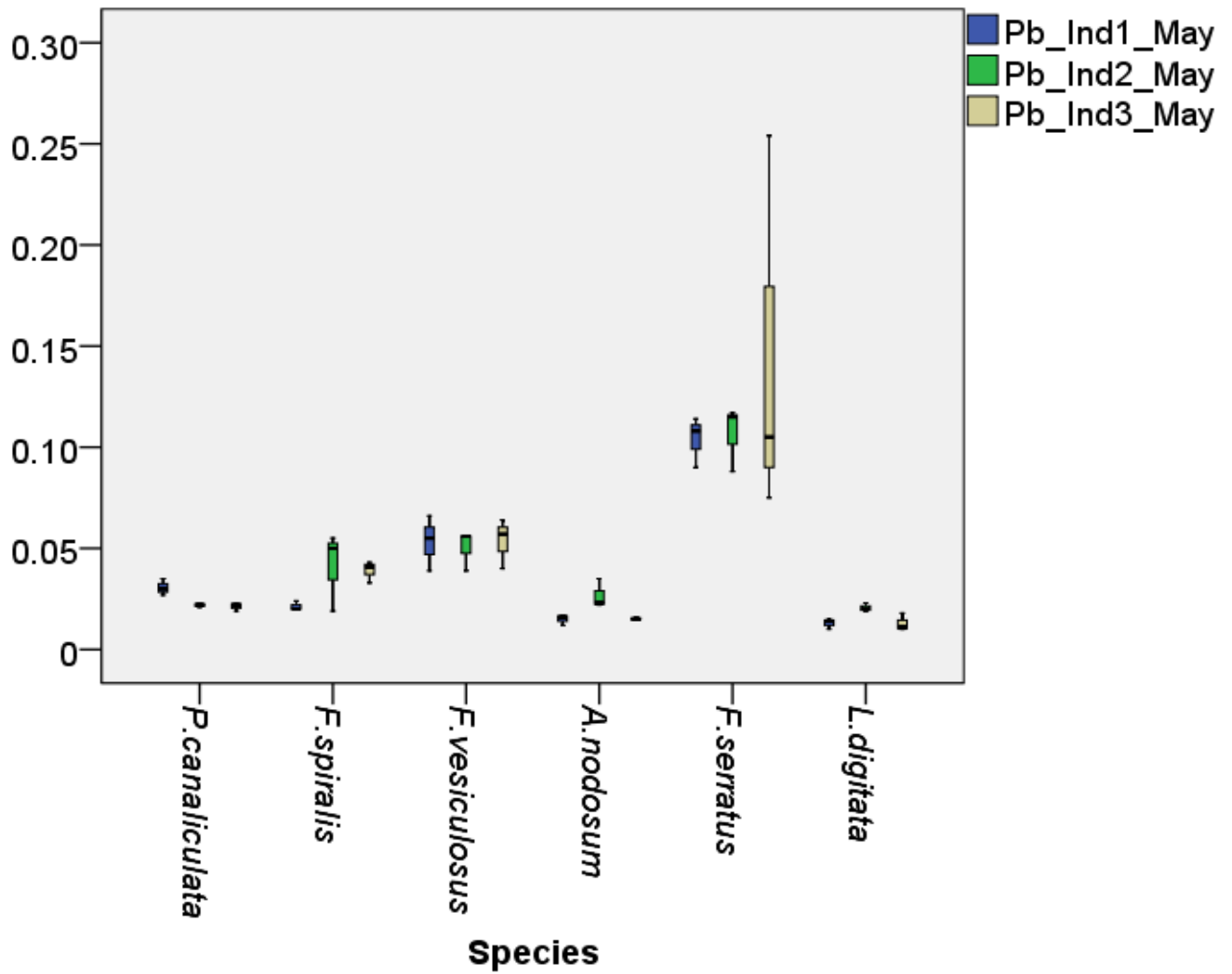


**Figure 35.** Average weight ( $\mu\text{g/g}$ ) of Nickel (Ni) in dry algal tissue *Pelvetia canaliculata*, *Fucus spiralis*, *Fucus vesiculosus*, *Ascophyllum nodosum*, *Fucus serratus*, and *Laminaria digitata*, from May 6<sup>th</sup> with specimen 1 (blue), specimen 2 (green) and specimen 3 (grey). The corresponding standard deviation values ( $\pm 2$  SD) are expressed with whiskers on each column.

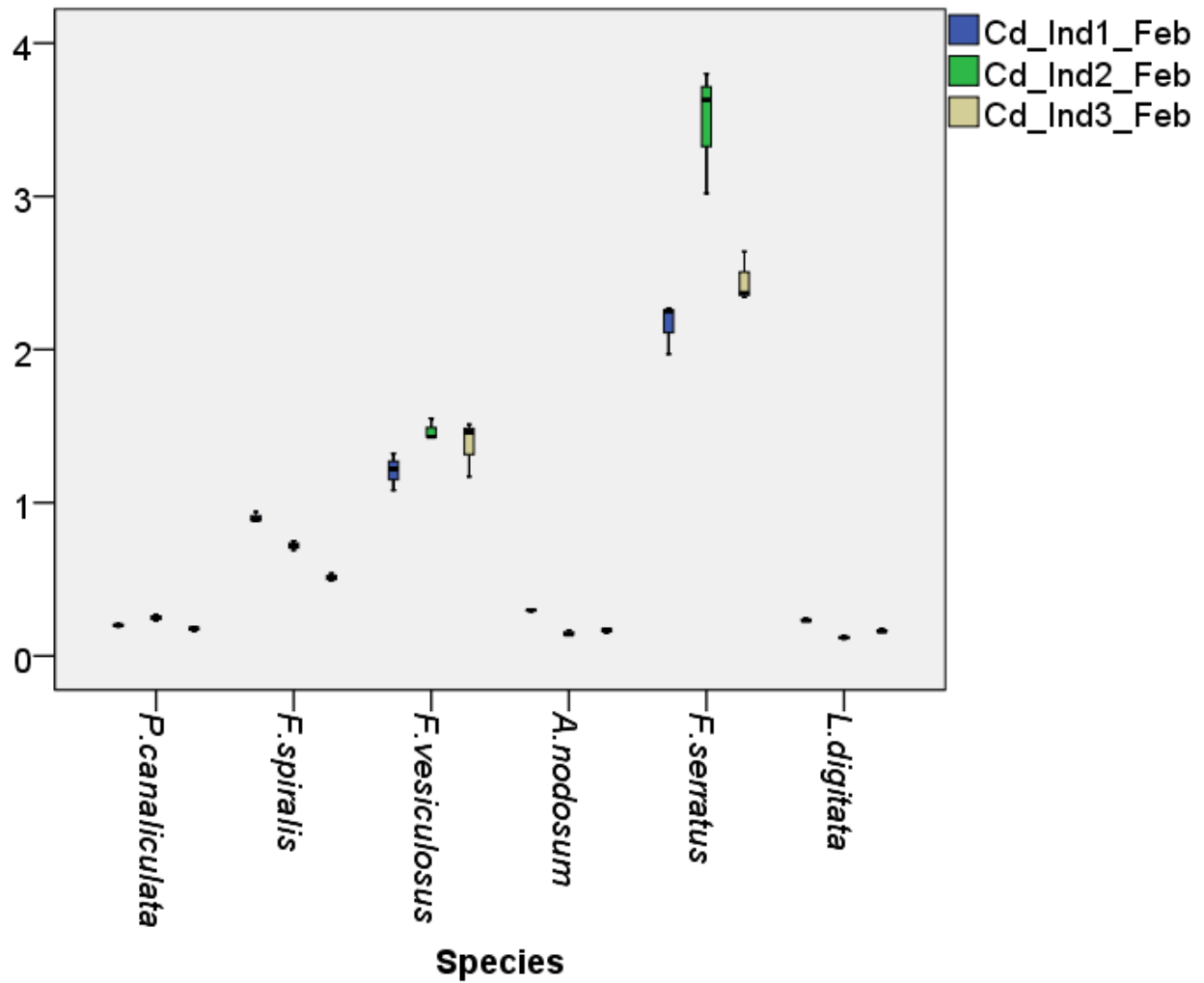


**Figure 36.** Average weight (µg/g) of Lead (Pb) in dry algal tissue *Pelvetia canaliculata*, *Fucus spiralis*, *Fucus vesiculosus*, *Ascophyllum nodosum*, *Fucus serratus*, and *Laminaria digitata*, from February 28<sup>th</sup> with specimen 1 (blue), specimen 2 (green) and specimen 3 (grey). The corresponding standard deviation values (±2 SD) are expressed with whiskers on each column.

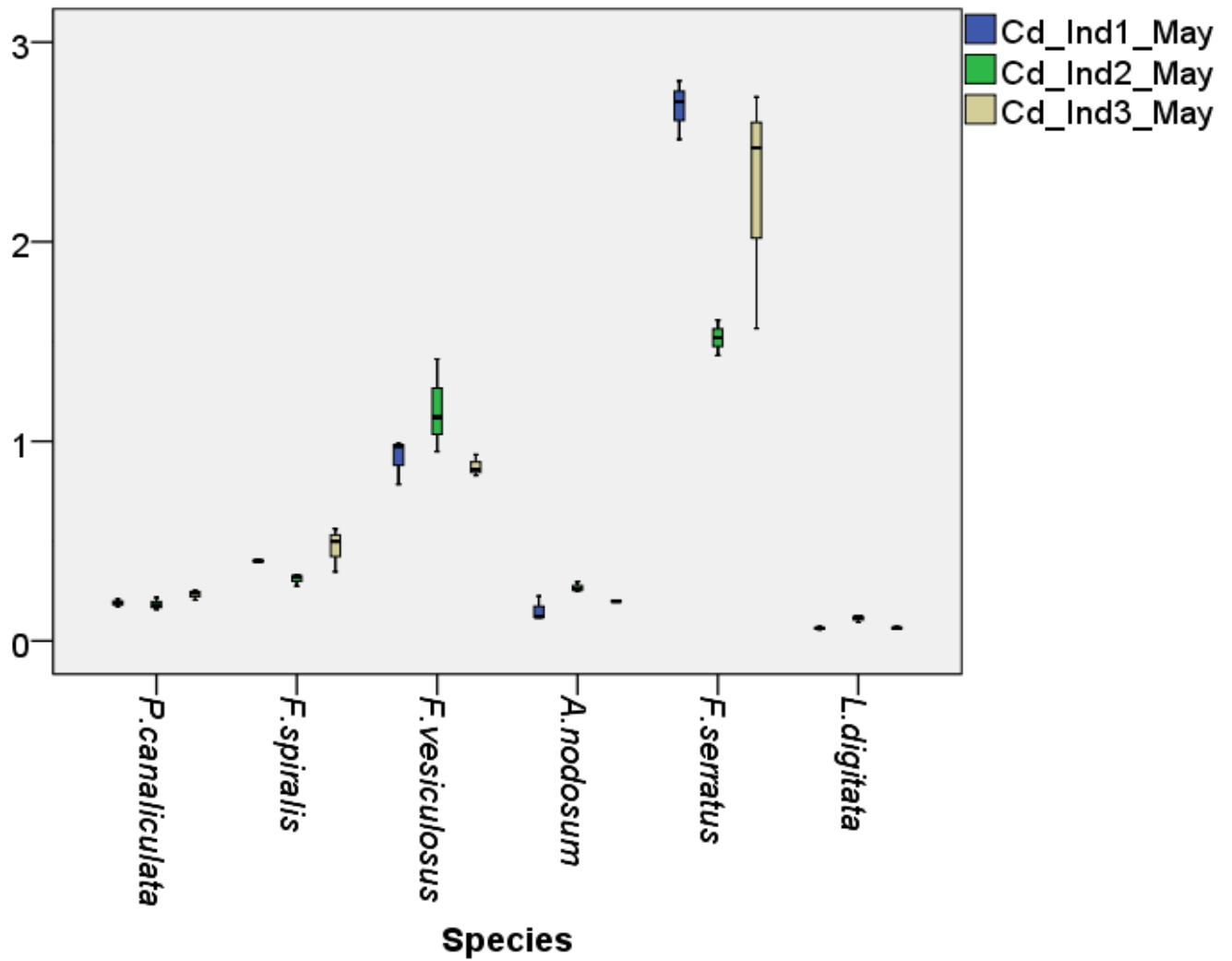




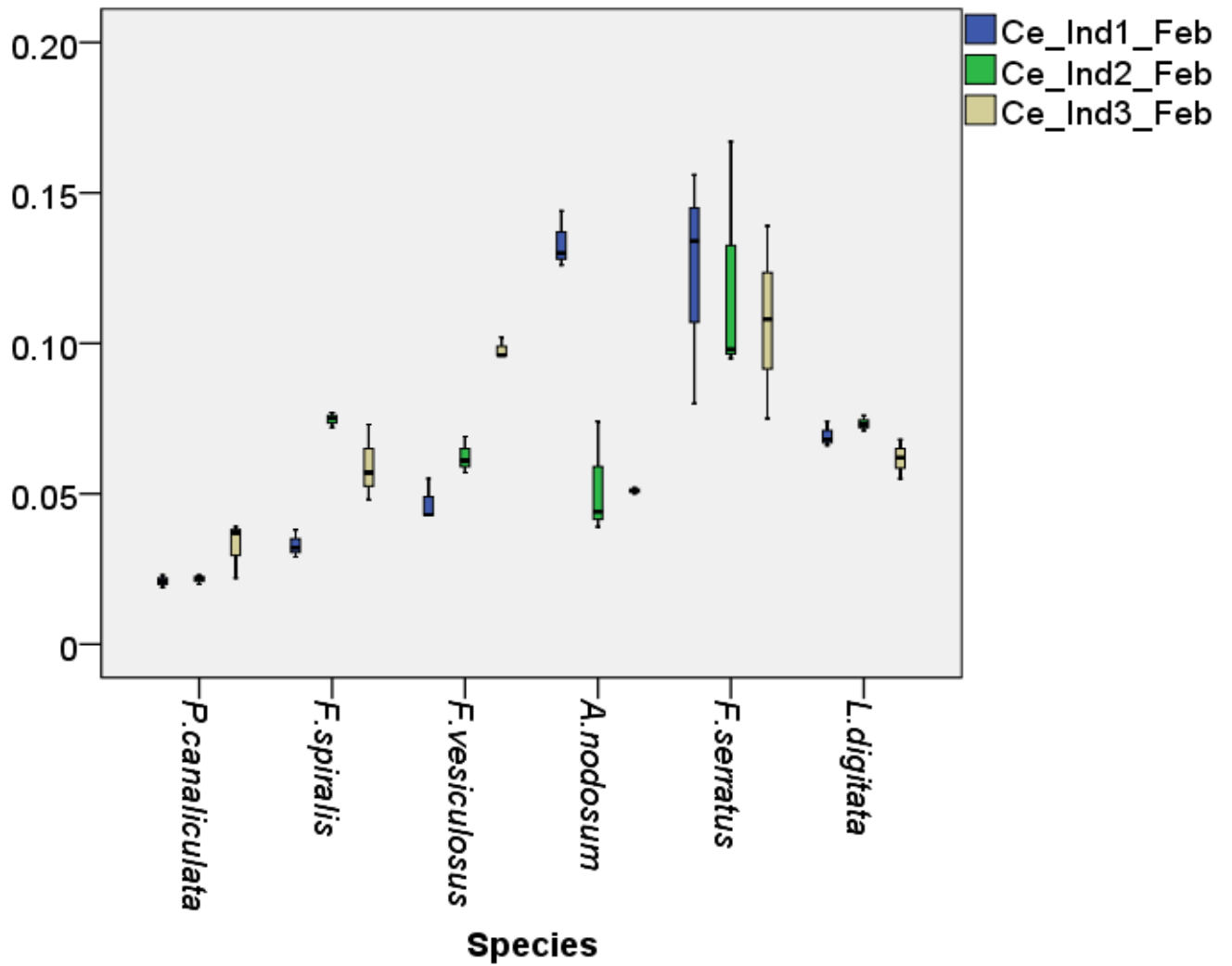
**Figure 37.** Average weight ( $\mu\text{g/g}$ ) of Lead (Pb) in dry algal tissue *Pelvetia canaliculata*, *Fucus spiralis*, *Fucus vesiculosus*, *Ascophyllum nodosum*, *Fucus serratus*, and *Laminaria digitata*, from May 6<sup>th</sup> with specimen 1 (blue), specimen 2 (green) and specimen 3 (grey). The corresponding standard deviation values ( $\pm 2$  SD) are expressed with whiskers on each column.



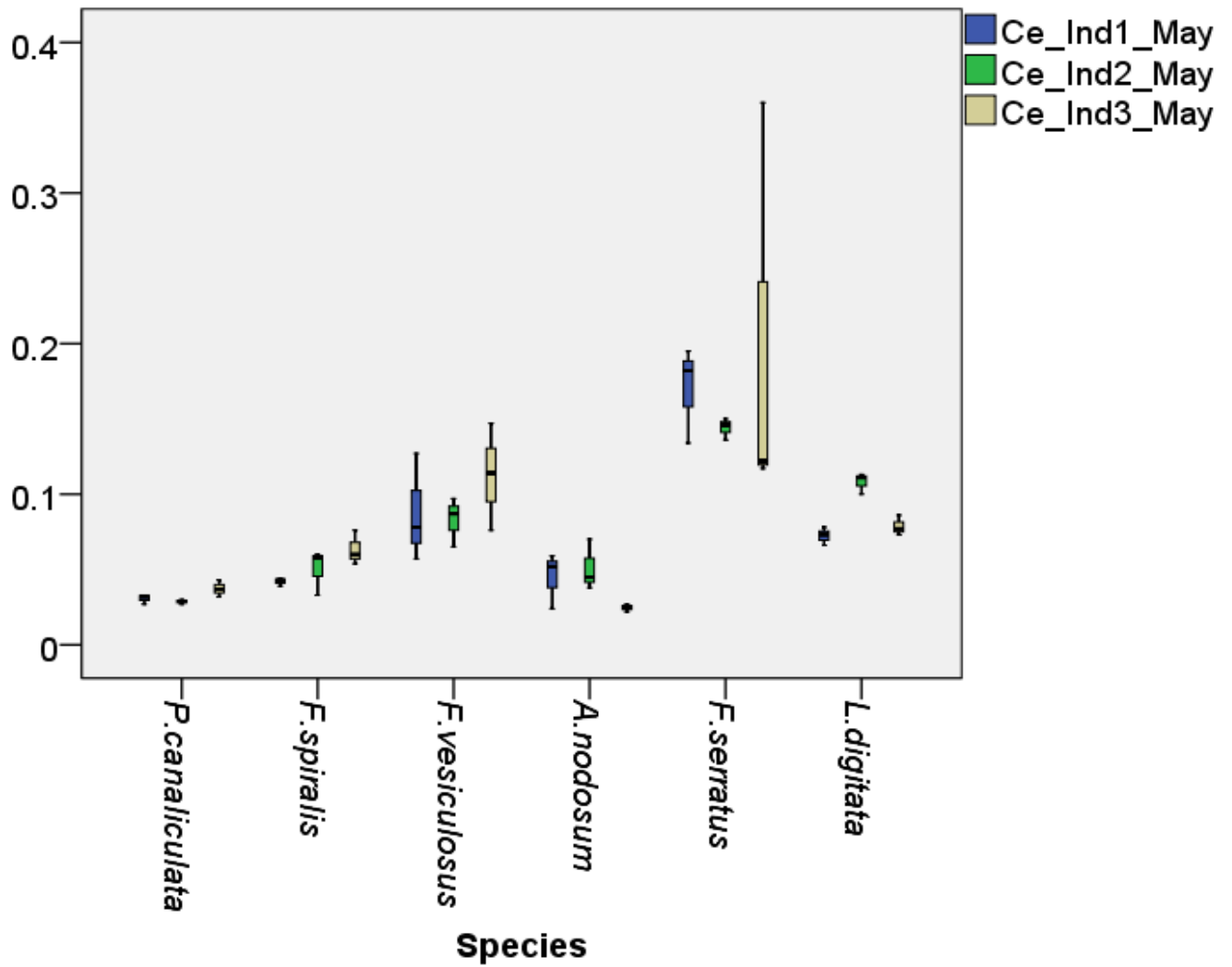
**Figure 38.** Average weight ( $\mu\text{g/g}$ ) of Cadmium (Cd) in dry algal tissue *Pelvetia canaliculata*, *Fucus spiralis*, *Fucus vesiculosus*, *Ascophyllum nodosum*, *Fucus serratus*, and *Laminaria digitata*, from February 28<sup>th</sup> with specimen 1 (blue), specimen 2 (green) and specimen 3 (grey). The corresponding standard deviation values ( $\pm 2$  SD) are expressed with whiskers on each column.



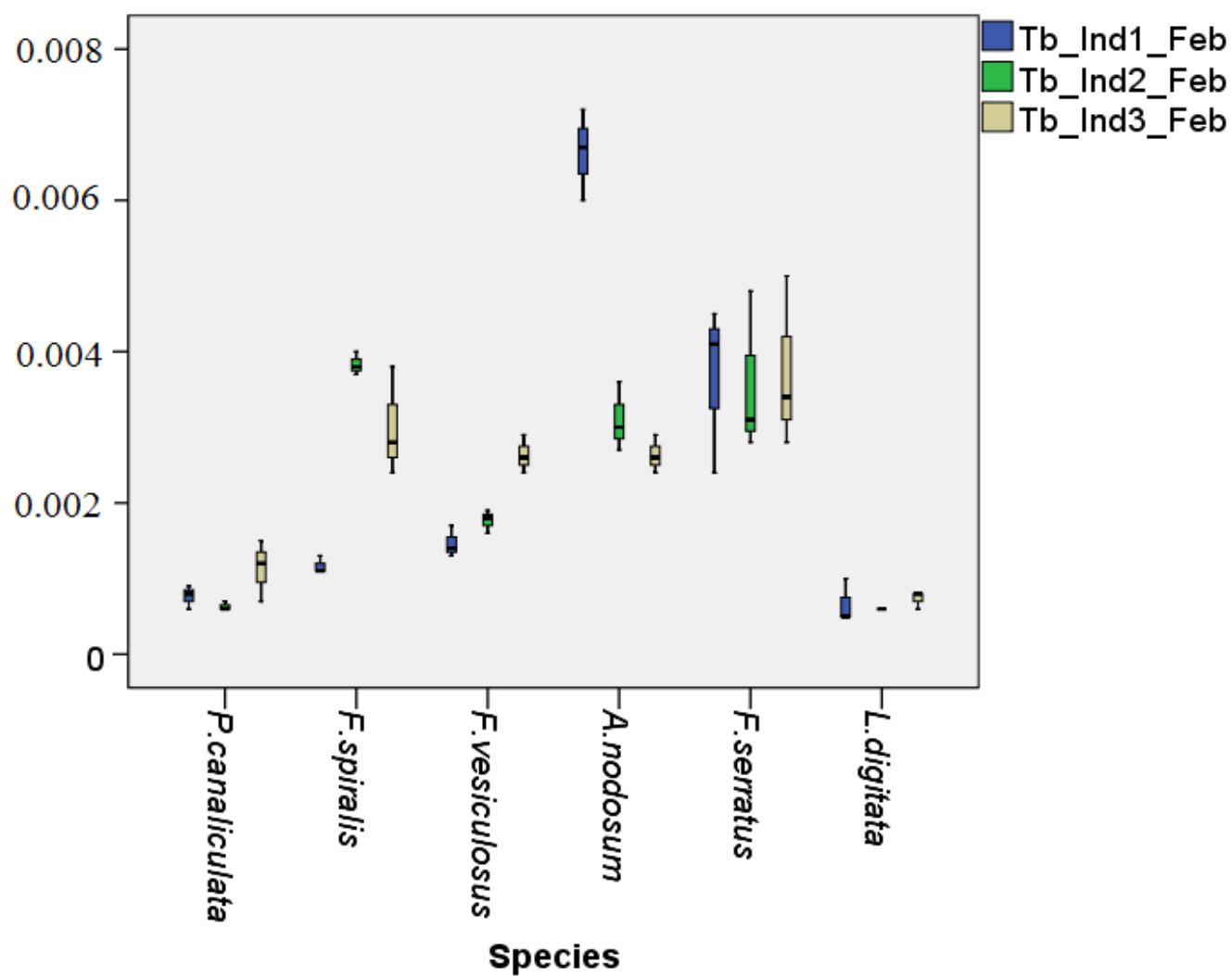
**Figure 39.** Average weight ( $\mu\text{g/g}$ ) of Cadmium (Cd) in dry algal tissue *Pelvetia canaliculata*, *Fucus spiralis*, *Fucus vesiculosus*, *Ascophyllum nodosum*, *Fucus serratus*, and *Laminaria digitata*, from May 6<sup>th</sup> with specimen 1 (blue), specimen 2 (green) and specimen 3 (grey). The corresponding standard deviation values ( $\pm 2$  SD) are expressed with whiskers on each column.



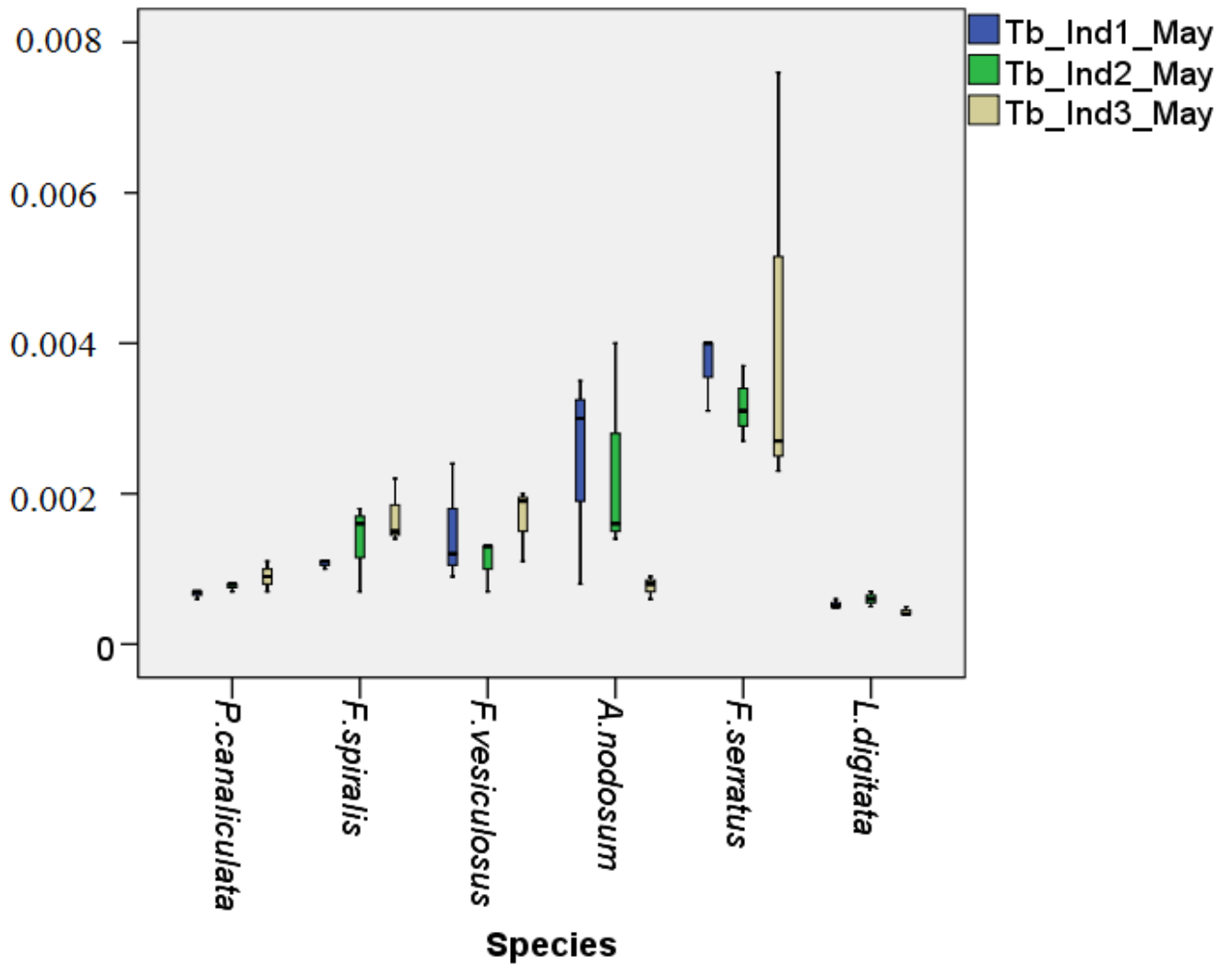
**Figure 40.** Average weight (µg/g) of Cerium (Ce) in dry algal tissue *Pelvetia canaliculata*, *Fucus spiralis*, *Fucus vesiculosus*, *Ascophyllum nodosum*, *Fucus serratus*, and *Laminaria digitata*, from February 28<sup>th</sup> with specimen 1 (blue), specimen 2 (green) and specimen 3 (grey). The corresponding standard deviation values ( $\pm 2$  SD) are expressed with whiskers on each column.



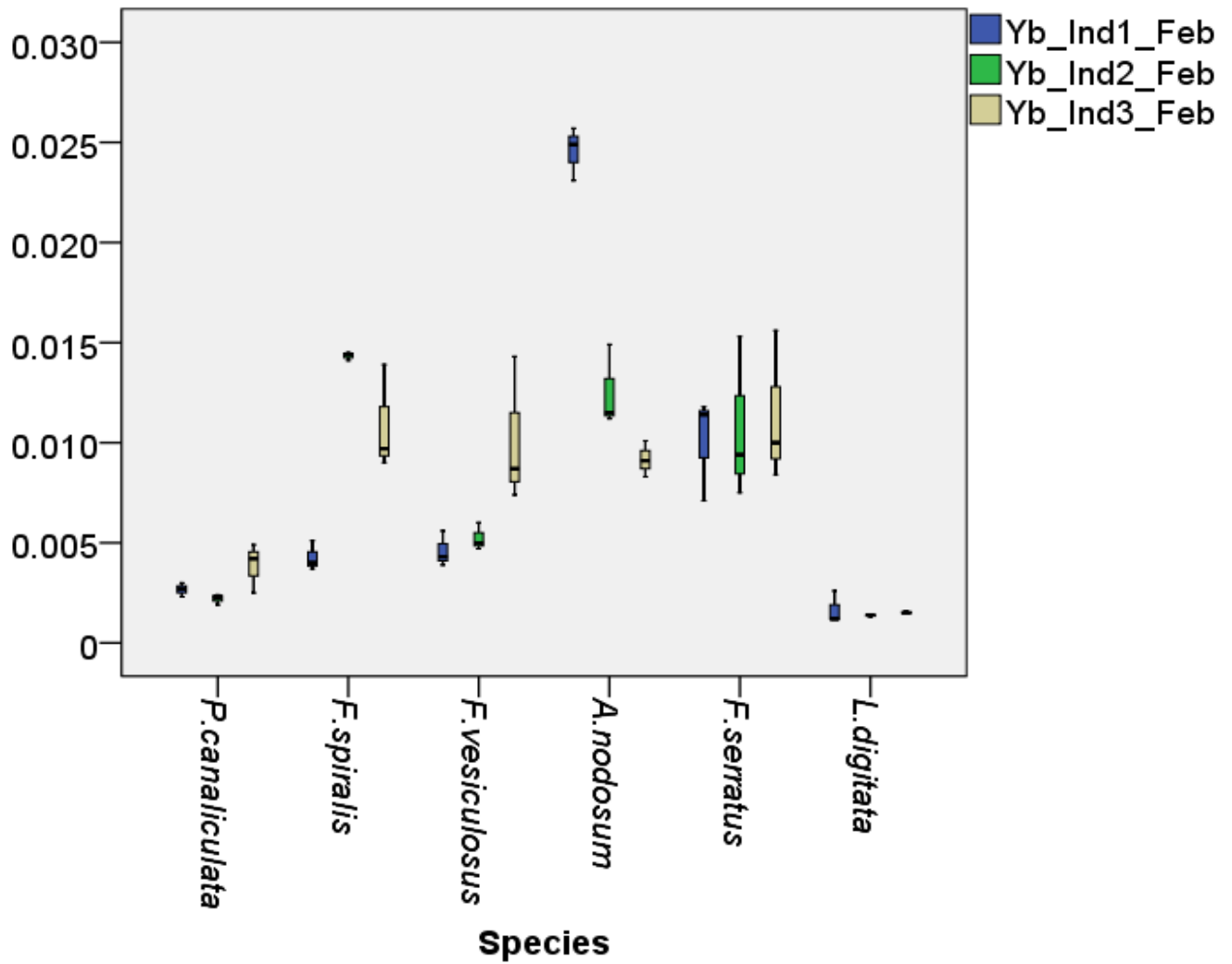
**Figure 41.** Average weight ( $\mu\text{g/g}$ ) of Cerium (Ce) in dry algal tissue *Pelvetia canaliculata*, *Fucus spiralis*, *Fucus vesiculosus*, *Ascophyllum nodosum*, *Fucus serratus*, and *Laminaria digitata*, from May 6<sup>th</sup> with specimen 1 (blue), specimen 2 (green) and specimen 3 (grey). The corresponding standard deviation values ( $\pm 2$  SD) are expressed with whiskers on each column.



**Figure 42.** Average weight ( $\mu\text{g/g}$ ) of Terbium (Tb) in dry algal tissue *Pelvetia canaliculata*, *Fucus spiralis*, *Fucus vesiculosus*, *Ascophyllum nodosum*, *Fucus serratus*, and *Laminaria digitata*, from February 28<sup>th</sup> with specimen 1 (blue), specimen 2 (green) and specimen 3 (grey). The corresponding standard deviation values ( $\pm 2$  SD) are expressed with whiskers on each column.

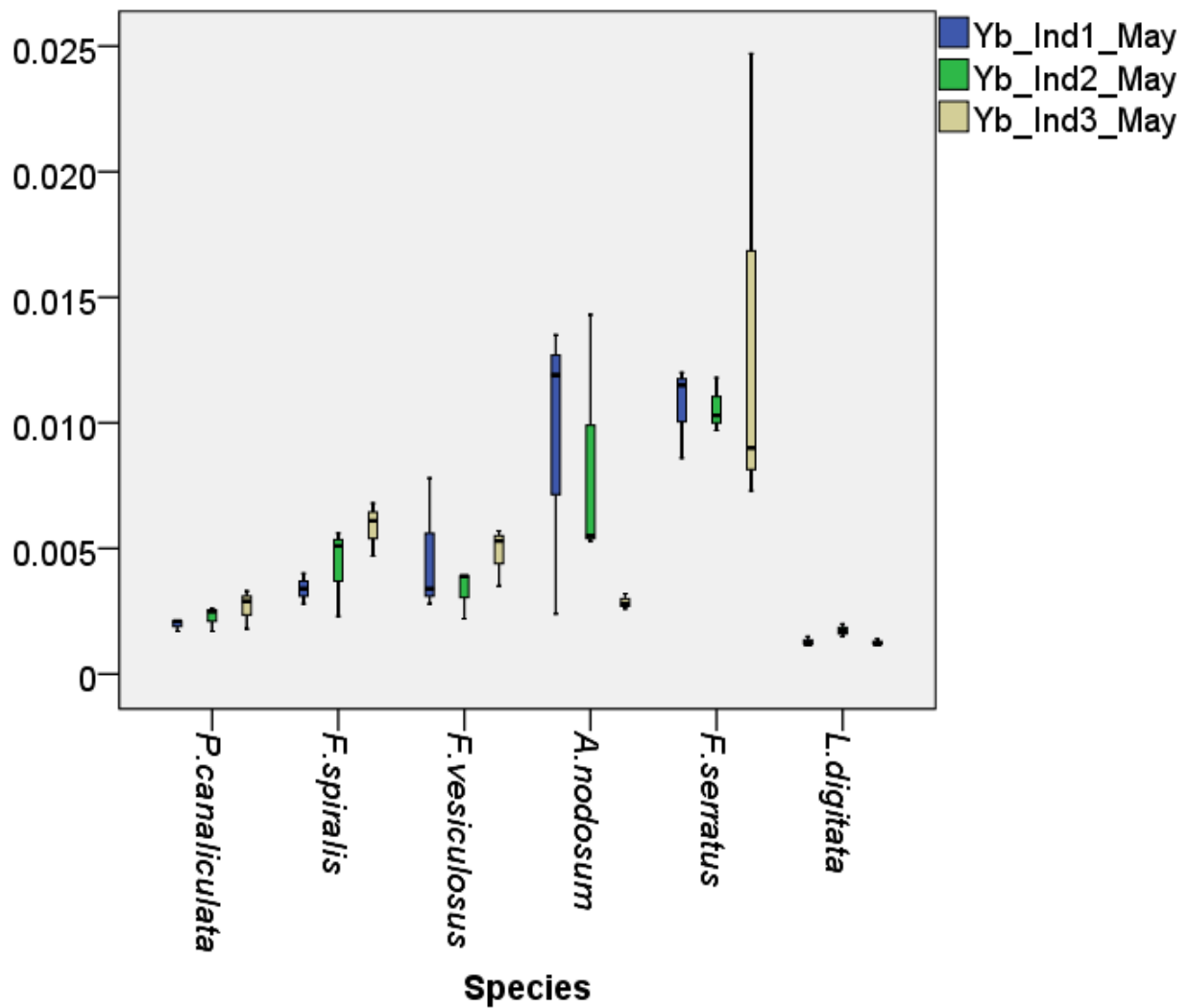


**Figure 43.** Average weight ( $\mu\text{g/g}$ ) of Terbium (Tb) in dry algal tissue *Pelvetia canaliculata*, *Fucus spiralis*, *Fucus vesiculosus*, *Ascophyllum nodosum*, *Fucus serratus*, and *Laminaria digitata*, from May 6<sup>th</sup> with specimen 1 (blue), specimen 2 (green) and specimen 3 (grey). The corresponding standard deviation values ( $\pm 2$  SD) are expressed with whiskers on each column.



**Figure 44.** Average weight ( $\mu\text{g/g}$ ) of Ytterbium (Yb) in dry algal tissue *Pelvetia canaliculata*, *Fucus spiralis*, *Fucus vesiculosus*, *Ascophyllum nodosum*, *Fucus serratus*, and *Laminaria digitata*, from February 28<sup>th</sup> with specimen 1 (blue), specimen 2 (green) and specimen 3 (grey). The corresponding standard deviation values ( $\pm 2$  SD) are expressed with whiskers on each column.





**Figure 45.** Average weight ( $\mu\text{g/g}$ ) of Ytterbium (Yb) in dry algal tissue *Pelvetia canaliculata*, *Fucus spiralis*, *Fucus vesiculosus*, *Ascophyllum nodosum*, *Fucus serratus*, and *Laminaria digitata*, from May 6<sup>th</sup> with specimen 1 (blue), specimen 2 (green) and specimen 3 (grey). The corresponding standard deviation values ( $\pm 2$  SD) are expressed with whiskers on each column.

## APPENDIX 5

## Variance estimates

**Table 47.** Variance Estimates Fe in species, individuals and replicates (Error) in %.

Component	Estimate
Var(species)	805,355 (78.9%)
Var(ind(species))	9,492 (0.9%)
Var(Error)	205,931 (20.2%)

Dependent Variable: Fe

Method: Minimum Norm Quadratic  
Unbiased Estimation (Weight = 1 for  
Random Effects and Residual)

**Table 48.** Variance Estimates Cu in species, individuals and replicates (Error) in %.

Component	Estimate
Var(species)	2,192 (50.2%)
Var(ind(species))	,467 (10.7%)
Var(Error)	1,708 (39.1%)

Dependent Variable: Cu

Method: Minimum Norm  
Quadratic Unbiased Estimation  
(Weight = 1 for Random Effects  
and Residual)

**Table 49.** Variance Estimates Co in species, individuals and replicates (Error) in %.

Component	Estimate
Var(species)	,899 (84%)
Var(ind(species))	,019 (1.6%)
Var(Error)	,169 (14.4%)

Dependent Variable: Co

Method: Minimum Norm  
Quadratic Unbiased Estimation  
(Weight = 1 for Random Effects  
and Residual)

**Table 50.** Variance Estimates of Zn in species, individuals and replicates (Error) in %.

Component	Estimate
Var(species)	1734,995 (73.2%)
Var(ind(species))	133,477 (5.6%)
Var(Error)	503,053 (21.2%)

Dependent Variable: Zn

Method: Minimum Norm Quadratic  
Unbiased Estimation (Weight = 1  
for Random Effects and Residual)

**Table 51.** Variance Estimate of Cd in species, individual and replicates (Error) in %.

Component	Estimate
Var(species)	,796 (88.6%)
Var(ind(species))	-,012 <sup>a</sup> (0%)
Var(Error)	,102 (11.4%)

Dependent Variable: Cd

Method: Minimum Norm

Quadratic Unbiased Estimation

(Weight = 1 for Random Effects and Residual)

Tot: 0.898

a. For the ANOVA and MINQUE methods, negative variance component estimates may occur. Some possible reasons for their occurrence are: (a) the specified model is not the correct model, or (b) the true value of the variance equals zero.

**Table 52.** Variance Estimates of Mn in species, individuals and replicates (Error) in %.

Component	Estimate
Var(species)	2236,657 (87.8%)
Var(ind(species))	-45,105 <sup>a</sup> (0%)
Var(Error)	423,226 (12.2%)

Dependent Variable: Mn

Method: Minimum Norm Quadratic

Unbiased Estimation (Weight = 1 for Random Effects and Residual)

Tot: 2659.883

a. For the ANOVA and MINQUE methods, negative variance component estimates may occur. Some possible reasons for their occurrence are: (a) the specified model is not the correct model, or (b) the true value of the variance equals zero.

**Table 53.** Variance Estimates in species, individuals replicates (Error) in %.

Component	Estimate
Var(species)	7,870 (68.4%)
Var(ind(species))	,451 (3.9%)
Var(Error)	3,188 (27.7%)

Dependent Variable: Ni

Method: Minimum Norm

Quadratic Unbiased Estimation

(Weight = 1 for Random Effects and Residual)

**Table 54.** Variance Estimates of Pb in species, individuals and replicates (Error) in %.

Component	Estimate
Var(species)	,001 (49.9%)
Var(ind(species))	7,275E-007 (0.2%)
Var(Error)	,001 (49.9%)

Dependent Variable: Pb

Method: Minimum Norm Quadratic

Unbiased Estimation (Weight = 1 for Random Effects and Residual)

**Table 55.** Variance Estimates of Ce in species, individuals and replicates (Error) in %.

Component	Estimate
Var(species)	,001 (47.8%)
Var(ind(species))	9,191E-005 (4.4%)
Var(Error)	,001 (47.8%)

Dependent Variable: Ce

Method: Minimum Norm Quadratic

Unbiased Estimation (Weight = 1 for Random Effects and Residual)

**Table 56.** Variance Estimates of Tb in species, individuals and replicates (Error) in %.

Component	Estimate
Var(species)	1,283E-006 (49.5%)
Var(ind(species))	3,329E-007 (12.8%)
Var(Error)	9,756E-007 (37.7%)

Dependent Variable: Tb

Method: Minimum Norm Quadratic

Unbiased Estimation (Weight = 1 for Random Effects and Residual)

**Table 57.** Variance Estimates of Yb in species, individuals and replicates (Error) in %.

Component	Estimate
Var(species)	1,465E-005 (44.7%)
Var(ind(species))	5,061E-006 (15.5%)
Var(Error)	1,303E-005 (39.8%)

Dependent Variable: Yb

Method: Minimum Norm Quadratic

Unbiased Estimation (Weight = 1 for  
Random Effects and Residual)

## APPENDIX 6

## Relative standard deviations for HR-ICP-MS

**Table 58.** Relative standard deviation values (average, minimum and maximum) for HR-ICP-MS instrument for all elements. These are standard deviations for all Phaeo-, Rhodo- and Chlorophytes. Confidence interval is 95% where <5 in green, 5-10 is black and >10 is red.

	<b>Ce</b>	<b>Tb</b>	<b>Yb</b>	<b>Fe</b>	<b>Mn</b>	<b>Ni</b>	<b>Zn</b>	<b>Cu</b>	<b>Co</b>	<b>Cd</b>	<b>Pb</b>
<b>Average</b>	2.9	7.7	10.4	3.3	3.3	4.1	2.6	3.7	4.4	3.2	2.1
<b>Min</b>	0.2	0.9	0.5	0.4	0.8	0.3	0.3	0.5	0.1	0.2	0.1
<b>Max</b>	8.7	32.2	49.9	7.4	9.1	18.3	6.1	10.1	25.2	8.7	5.8