



Norwegian University of
Science and Technology

Design and simulations of Refrigerated Sea Water Chillers with CO₂ ejector pumps for marine applications in hot climates

Jakub Bodys

Master of Energy and Environmental Engineering

Submission date: July 2017

Supervisor: Armin Hafner, EPT

Co-supervisor: Krzysztof Banasiak, SINTEF Energy
Jacek Smolka, Silesian University of Technology

Norwegian University of Science and Technology
Department of Energy and Process Engineering

RAMS

Reliability, Availability,
Maintainability, and Safety

Design and simulations of Refrigerated Sea Water Chillers with CO₂ ejector pumps for marine applications in hot climates

Jakub Bodys

July 2017

MASTER THESIS

Department of Energy and Process Engineering
Norwegian University of Science and Technology

Supervisor 1: Armin Hafner, Professor at NTNU, Trondheim, Norway

Supervisor 2: Krzysztof Banasiak, Research Scientist at SINTEF Energy Research, Trondheim,
Norway

Supervisor 3: Jacek Smolka, Associate Professor at Silesian University of Technology, Gliwice,
Poland

Preface

During my studies of the first degree, several activities in the area of numerical simulations with utilisation of Computational Fluid Dynamics methods took place. A vast majority of mentioned activities were focused on the analysis of a state-of-the-art generation of refrigeration units operating with carbon-dioxide. Contribution in a international research project realised by consortium of Institute of Thermal Technology (Silesian University of Technology) and SINTEF Energy Research allowed for working at transcritical carbon-dioxide ejectors. During this activity, six scientific papers were published and two presentations at international conferences were given. All mentioned activities were supervised by Prof. Jacek Smolka. Finally, co-operation with other project members resulted in productive period of Bachelor studies.

This Master Thesis project was realised on the basis of an international student exchange programme ERASMUS+ during Spring semester 2017. NTNU was chosen as a receiving institution due to previous cooperation with Prof. Armin Hafner (Department of Energy and Process Engineering, NTNU) and Dr Krzysztof Banasiak (SINTEF Energy Research). Content and main goals of the thesis was given by Prof. Armin Hafner according to partnership with Kuldeteknisk AS represented by Dr Yves Ladam. Kuldeteknisk AS is an entrepreneur in Tromsø and partner in FME HighEFF delivering refrigeration systems to most types of users such as industrial, supermarket and office buildings. The company has distinguished itself in the market as innovative and operates continuously with small and larger R & D activities for its customers.

On the basis of developed by Kuldeteknisk AS carbon-dioxide refrigeration unit called Refrigerated Sea Water (RSW) Chiller and positive results of its operation at Norwegian fishing vessels, further development was expected. Analysis on applicability of this technology for hot climates market such as the Mediterranean and Asian was main motivation. The partnership with Kuldeteknisk AS allowed for obtaining the measurement data from a control terminal at the fishing vessel. The data was used in a numerical model development. As a result of the investigation, a report of possible system modifications for hot climates application were provided and discussed with the industrial partner.

Trondheim, 2017-07-17

Jakub Bodys

Acknowledgment

I would like to thank Prof. Armin Hafner and Dr Krzysztof Banasiak for their support and time during preparation of this thesis. Moreover, I thank for whole co-operation so far in the area of CO₂ systems and ejectors analysis.

I would like to thank and emphasize great contribution and support of my supervisors during whole period of studies. I am gratefully thankful to Prof. Jacek Smolka for his never-ending support during work in CO₂ projects, publication activities and overall care of my personal development. I would like to express my great thanks to project team related with ejector research at Institute of Thermal Technology, especially to Prof. Andrzej J. Nowak, for their trust and help during my education under their wings. Many thanks to Dr Michal Palacz and PhD student Michal Haida for wide range of their help and skills shared in the field of numerical simulations.

Last but not least, I am gratefully thankful to my family for patience and care in every area of my personal and student life. Nothing would be possible without fundamentals and manners which I have obtained at home.

Finally, I am immensely thankful to my fiancée Magda for her understanding and support in every case, in every moment. I can never thank you enough.

J.B.

Summary and Conclusions

According to provided literature review, many investigations concerned improvement possibilities of carbon-dioxide refrigeration units. Basis for further development of this technology are located in environmentally friendly working fluid, law regulations and large possibilities of further performance improvement of these systems. Several applications including large units operating for cooling and heating purposes of supermarkets and food industry, transport industry as well as whole district heating systems were successfully implemented to the market. Thermodynamic character of carbon-dioxide required many performance improvement based on various system configurations and control strategies, especially in hot climates as Mediterranean. However, mentioned applications are characterised by no limits of available space for system equipment. Whereas, these limitations is one of the major challenges in the case of marine industry and fishing vessels.

Matter of performance in higher temperatures of operation and limited space at fishing vessel was main challenges of the thesis. Meanwhile, conditions of higher ambient temperatures are related with higher power consumption for the same cooling capacity. Such a situation is mostly related with necessity of additional compressors unit. Proposal of system modification according to mentioned factors was stated as a main goal of the project. On the basis of measurement data delivered by Kuldeteknisk AS, mathematical model of baseline installation was developed. Several crucial factors as heat exchanger capacity, system power consumption and ejector operation had to be taken into consideration. Proposed alternative system layouts were analysed on the basis of proper sets of operating conditions characteristic for high ambient conditions.

Series of simulations for various climate zones were performed in order to evaluate systems performance. Having regard that an additional compressor increases the space requirement, analysis of modifications in the light of limited space and reduction of power demand were performed. Obtained results allowed for performance comparison of baseline installation working at Norwegian coast with modified systems in warm climates. Finally, up to 70% of performance improvement was obtained in the case of most advanced installation working in warm east-Asian waters. Provided results showed that proper design of the system should ensure no ne-

cessity of an additional compressor in warmer climates with maintaining of the same cooling capacity. Hence, the described system could be implemented to the other markets bringing ecological and advanced solutions suitable for more demanding operation conditions.

Contents

| | |
|--|-----------|
| Preface | i |
| Acknowledgment | ii |
| Summary and Conclusions | iii |
| 1 Introduction | 2 |
| 1.1 CO ₂ global phase-in, environmental and safety benefits | 2 |
| 1.2 Challenging ambient conditions in warmer climates | 4 |
| 1.3 Study motivation | 8 |
| 2 Refrigerated Sea Water installation | 10 |
| 2.1 Scandinavian operation - Baseline System | 10 |
| 2.2 RSW system in high ambient temperatures | 13 |
| 2.3 R744 cycle modelling - Baseline and modified configurations | 19 |
| 3 Results discussion of Baseline and modified RSW systems | 23 |
| 3.1 RSW installation in northern Norwegian conditions | 23 |
| 3.2 Proposed modifications for hot climates applications | 24 |
| 3.3 System modifications according to power demand increment | 32 |
| 4 Conclusions and further work | 41 |
| 4.1 Performance analysis in various ambient conditions of three proposed system mod- ifications | 41 |
| 4.2 Modification requirements according to the space constrains at the fishing vessel . | 43 |
| 4.3 Further work | 45 |

| | |
|---|-----------|
| <i>CONTENTS</i> | 1 |
| A Nomenclature | 46 |
| B Carbon-dioxide as a working fluid | 49 |
| B.1 Background | 49 |
| B.2 Thermodynamic characteristic | 49 |
| B.3 Environmental and economic features | 53 |
| B.4 Classical R744 refrigeration unit | 55 |
| B.5 Improvement possibilities in the case of hot climates application | 58 |
| B.6 Fundamentals of mathematical modelling approach implemented to Engineering Equation Solver | 62 |
| Bibliography | 67 |

Chapter 1

Introduction

1.1 CO₂ global phase-in, environmental and safety benefits

Corresponding to the first turn in global trends of refrigerants presented by Montreal ([United Nations Environment Programme \(UNEP\), 1987](#)) and Kyoto ([United Nations Framework Convention on Climate Change \(UNFCCC\), 1997](#)) protocols, next steps in a direction of environmentally friendly working fluids have already been done. According to Global Warming Potential (GWP) and Ozone Depletion Potential (ODP), regulation presented by European Commission ([European Commission, 2014](#)) ensures no limits for natural working fluids such as an ammonia (NH₃, R717), hydrocarbons (HC) or a carbon-dioxide (CO₂, R744). According to the listed natural refrigerants, the last one ensures many additional advantages besides a global environment safety. When applying R744 (CO₂), local safety of an exploitation and transport is provided by non-toxic, non-flammable characteristic and, as a consequence, the least stringent safety class ([American Society of Heating Refrigerating and Air-Conditioning Engineers, 2016](#)). It is worth to notice that both ranges of safety should be satisfied - global and local. Meanwhile, produced synthetic refrigerants characterised by very low GWP factor might simultaneously having a serious disadvantages. Namely, decomposition processes (with or without fires) of these ultra-low GWP synthetic refrigerants results in toxic products such as a trifluoroacetic acids (TFA) or hydrogen fluoride (HF) with real danger to human health in closed spaces such as garages ([Hurley et al., 2008](#)). On the other hand, refrigerants from R1234 group are characterised by safety class A2/L, where possibility of a safe service and maintenance were confirmed ([Imamura et al., 2015](#)).

Analysis of alternative mixtures based on a hydrofluorocarbons (HFC) and hydrofluoroolefins (HFO) in order to substitute high GWP refrigerants were provided as well (Mota-Babiloni et al., 2015). Nevertheless, this study presented comparison of economic benefits showing that R744 is more efficient solution than mentioned mixtures.

CO₂ industrial applications benefits

Economic and technical aspects of R744 application provides the same positive perspective as aforementioned environmental factors and law regulations. This is due to thermodynamic properties of R744 which result in high performance operation of real cycle (Jin et al., 2017). Firstly, levels of high- and low- pressure sides provides lower pressure ratio than traditional halocarbons. Consequently, higher efficiency of compressors operation is provided (Lorentzen, 1994), (Joneydi Shariatzadeh et al., 2016). In addition to lower pressure ratio, pressure values in R744 system are higher than in classical units with i.e. tetrafluoroethane (R134a). This provides lower specific volume and smaller size of compressor - and further lower investment costs (Lorentzen, 1994), (Lorentzen, 1995). Moreover, smaller size of heat exchangers can be obtained according to relatively high volumetric refrigeration capacity (VRC) and high heat transfer coefficients in CO₂ flow. Next, very low temperature drop with corresponding pressure drops in the installation allows for designing smaller piping system with higher velocity of flowing working fluids. This features can be summed up by compact sizing of R744 installation and high performance of operation (Lorentzen, 1995).

Compact sizing and high performance of RSW installation at fishing vessel

The described thermodynamic and ecologic features found an application in fishing vessels refrigeration units where cooling of a catch during transportation is one of the crucial factors of a final fish quality. Nevertheless, quantity of catch is important for economic balance as well. Due to this, refrigeration unit and its equipment should concern machinery space limitations and maximum refrigerated storage space. Hence, aforementioned compact sizing and satisfactory performance allowed for developing refrigeration unit for fishing vessels applications. Such an installation was developed by Kuldeteknisk AS as a one of new marine applications of R744

refrigeration units. Namely, the catch is cooled by Refrigerated Sea Water (RSW) Chillers where water temperature in storage tank is maintained on the level of -1°C . In Scandinavian ambient conditions where heat rejection is ensured by relatively cold sea water ($5\text{-}12^{\circ}\text{C}$), such an operation results in high performance of refrigeration unit without sacrificing large amount of space for installation components. Having on regard ecological aspects related with green label of R744, such an installation found numerous applications at Norwegian fishing vessels.

1.2 Challenging ambient conditions in warmer climates

Thermodynamic challenges for CO_2 cycle in hot ambient conditions

Nevertheless, besides the mentioned advantages some challenging areas have to be taken into account for a further development process. One of such challenges is an operation in high ambient conditions, such as southern Mediterranean coast or Indonesian climates. Moreover, in the case of CO_2 installation, ambient conditions could be described as a crucial factor which influences system efficiency. Reasons are related with thermodynamic properties of the working fluid. Namely, relatively low temperature of critical point (30.98°C) ([IPU & Department of Mechanical Engineering of Technical University of Denmark, 2017](#)) enforces cycle to operate in transcritical mode. In practice, transcritical operation is necessary when the heat rejection temperature is above approximately 28°C what is related with necessary temperature difference in a heat exchanger. In addition, transcritical mode results in high expansion losses which affects system Coefficient of Performance (COP) in the negative way ([Lorentzen, 1994](#)), ([Lorentzen, 1995](#)). Hence, more advanced solutions have to be utilised in the case of R744 refrigeration unit.

Developed technologies for cycle improvement - flash gas utilisation, parallel compression

In order to maintain applicability of RSW system and its advantages in hot climates such as south Europe or Asia, some improvements could be introduced to CO_2 refrigeration cycle. Literature reports several studies where positive influence of various components configurations

were described. These solutions were developed on the basis of other CO₂ applications such as supermarkets heating and cooling systems (Hafner et al., 2014), (Polzot et al., 2017), (Tsamos et al., 2017), mobile refrigeration units (Hafner, 2016) or residential heat pumps (Minetto et al., 2016), (Ignacio et al., 2017). One of the basic modifications, is based on introduction of an intermediate pressure receiver to refrigeration cycle. Then, liquid and flash gas separation brings positive results in the matter of heat of evaporation enhancement. Next generation of R744 units equipped in additional compressors which work in parallel mode with base compressor provided further improvement.

Intermediate Pressure Receiver implementation for flash gas utilisation and development of the parallel compression for flash gas

Fundamental modification of R744 system is based on the introduction of intermediate pressure receiver, sometimes called liquid receiver. Pressure in this tank is maintained at the intermediate level between high- and low- pressure side what leads to liquid and gas separation. Thus overfeeding of evaporator is possible by separated liquid line. Potential energy savings of this solution was described in the work of Gullo (Gullo et al., 2016a). These authors theoretically analysed refrigeration system for supermarket applications in three cities characterised by high year-averaged temperatures - Rome (Italy), Valencia (Spain) and Seville (Spain). Investigation showed up to 9.6% COP improvement in combined case with evaporator overfeeding and parallel compression mode in comparison to cycle of based on a refrigerant R404A. In the work of Carvalho (Carvalho et al., 2016), solution based on the liquid receiver tested in a smaller CO₂ refrigeration unit was presented. Crucial influence of the green label related with R744 were underlined as a significant factor in whole application process. Nevertheless, investment cost of liquid receiver and additional equipment was evaluated to be high having regard the obtained performance improvement. On the other hand, compact sizing of CO₂ showed possibility of application for small units of 1 kW power. Similar challenges in the investment costs area are related with mentioned HFO working fluids thus most of first applications are focused on Mobile Air Conditioning and small domestic refrigerators (Mota-Babiloni et al., 2017). Higher performance of the R744 system was presented by Sarkar (Sarkar and Agrawal, 2010), however larger

installation was analysed. The authors investigated various configurations based on the parallel compression idea. In the case of the most promising parallel compression with economiser, COP increment was equal to 47.3%. Cases of smaller temperature differences resulted in COP improvement on the level of 15%.

Heat recovery and cooling/heating systems integration

Further possibilities of system improvement are related with a proper integration of heating and cooling functions. Fully integrated process of a building design process becomes a standard indicator of well planned state-of-the-art investment (Ruan et al., 2016). In the case of the R744 system operating in the transcritical mode, amount of available heat for recovering is relatively high in comparison to the classic hydrofluorocarbons cycle. Moreover, gliding temperatures of the heat rejection in the case of the transcritical carbon-dioxide unit provides small amount of the heat exchanger losses, especially with proper designed stages of the heat recovery. These stages can cover different demand of temperature level for various purposes such as a ice melting, a floor heating or a hot tap water production (Polzot et al., 2017), (Ignacio et al., 2017).

Direct and indirect work recovery - ejectors as the most perspective solution

Beside of the heat recovery approach, work recovery of expansion losses is a perspective way for improvement of unit COP. Aforementioned expansion losses could be described as a large potential for the work recovery in the R744 system (Lorentzen, 1995). Direct and indirect work recovery of expansion process were described and brings satisfactory results. However, according to a reliability, direct solutions in the form of gear expanders or turbines could be described as less demanded in mobile units. The mentioned reliability can be provided by devices with no moving parts and simple construction. Such features are delivered by introducing ejectors into transcritical CO₂refrigeration system (Elbel and Lawrence, 2016). The recovered work could be received in two ways regarding actual needs. The ejector operation can be focused on the pressure increment before suction ports of compressors resulting in lower energy demand. On the other hand, ejector provides pumping effect and recirculation of liquid CO₂ resulting in lower mass flow rate through compressors section. In consequence, it provides lower compressors

work.

Applications of singel and parallel working fixed ejectors

Study focused on the ejector application and the refrigeration cycle improvement were ensured by Elbel and Hrnjak (Elbel and Hrnjak, 2008). This study concerned various operating conditions for the R744 ejector refrigeration system with internal heat exchanger (IHX). According to this experimental research, the system COP was improved by 8% in comparison to the traditional system based on the throttling valve. Moreover, extrapolation of results showed possibility of even 18% COP improvement with proper cooling capacities. Nevertheless, the reported ejector efficiency was below 20%, hence the results of this study could show even better perspective for such a system after improvement of work recovery efficiency.

An experimental comparison provided by Lucas, showed 17% of COP improvement due to the ejector implementation (Lucas and Koehler, 2012). The authors investigated influence of the high pressure side on the ejector performance and overall performance of the system. The range of investigated gas cooler temperatures was constrained from 30°C to 40°C, while the evaporation temperatures were between -10°C and -1°C. The assumed range of operating conditions and the aforementioned COP improvement showed good possibilities of the R744 transcritical system operation in relatively high ambient conditions. According to the described ejector solution, fully developed solutions were presented for such an application as the supermarket refrigeration system (Hafner et al., 2014). These authors described idea of parallel working ejectors in order to cover various system loads with simultaneously high efficiency of these devices. Several authors investigated this solution based on the multi-ejector block. Performance mapping of multi-ejector block was delivered on the basis of laboratory test and described in the work of Banasiak (Banasiak et al., 2015). The presented results of block performance in the wide range of operating conditions characteristic for supermarket operation delivered efficiency range in the function of pressure ratio (the outlet to the suction pressure) and the motive pressure. Depending on the mentioned parameters, the efficiency was enclosed in a range from 12% to 33% for the pressure ratio 1.1 and 75 bar to the pressure ratio 1.3 and 95 bar, respectively. The mentioned efficiency of multi-ejector block is possible to be described by the same function as a single ejector according to used definition (Elbel and Hrnjak, 2008). Further analysis of global multi-ejector

system were provided by Haida (Haida et al., 2016). The authors described comparison of PC and multi-ejector system performance in laboratory test rig based on high ambient temperatures. The obtained results showed up to 8% of system COP improvement when operating in the multi-ejector mode. Numerical analysis of multi-ejector block performance was performed in cooperation with the authors of the mentioned experimental tests (Bodys et al., 2017). According to these results, even higher efficiency of 38% could be obtained when pressure drops in collectors are reduced. Moreover, the first studies on multi-ejector implementation to a heat pump system were provided as well (Boccardi et al., 2017). Having regard that concept of this device was planned for refrigeration applications (Hafner et al., 2014), it could be said that constant development of this technology is visible.

1.3 Study motivation

In this study, investigation of a modified RSW installation for fishing vessels operating in high ambient conditions is provided. To the best author knowledge, an investigation on the R744 installation for fishing vessel with constrained space in machinery room were not provided in the literature. Baseline case with the liquid ejector designed for Scandinavian conditions was simulated on the basis of a developed mathematical model and measurement data from the actual working RSW installation (Kuldeteknisk AS, Tromsø). High efficient operation of actually operating unit at northern Norwegian coast was confirmed. In order to investigate system performance in high ambient conditions, the developed baseline model was modified by introduction of the intermediate pressure receiver and the parallel compression of flash gas. Moreover, additional model of multi-ejector system was developed and simulated as well. On the basis of satellite data, Mediterranean and east-Asian waters were chosen as a representative high-temperature climates. Parameterisation of operating conditions delivered data of the most efficient systems operation. Simulated configurations were compared in the light of the system COP and space requirements. Additional equipment was analysed and discussed in order to propose the best solution having regard performance and necessary modifications for each of analysed climates. Finally, relation between multi-ejector module efficiency and system performance was discussed. Overall conclusion on the most perspective modification of RSW

installation were stated.

Chapter 2

Refrigerated Sea Water installation

2.1 Scandinavian operation - Baseline System

Baseline System of the analysed RSW installation is presented in Fig. 2.1. Similar installations satisfies refrigeration purposes of the fishing vessel in the region of north Norway. This CO₂ cycle is built on the basis of the cycle proposed by Gustav Lorentzen (Lorentzen, 1995), nevertheless a liquid ejector was implemented as a additional component. Additional control and measurement equipment was marked by frames with proper letter, where T is temperature measurement, P is pressure measurement and V is flow measurement. Moreover, in Fig. 2.1 state points used in further calculations were marked. An operation of the installation is focused on cooling the water from a storage tank loop, where the set-point temperature of the water is approximately -1°C. Heat rejection is ensured by a sea water supplied condenser. Scandinavian conditions ensure inlet temperature of the water usually below 10°C. The analysed installation is equipped in two compressors of maximum electrical power consumption equal to 44 kW each at 34.85 bar evaporation pressure and 10 K superheat (GEA, 2017). The suction gas is supplied from an internal heat exchangers (IHX) separately for each compressor. An evaporator load varies depending on the water storage tank load and the share of fresh water. From the refrigerant side, the evaporator is supplied by a stream expanded in a throttling valve and the ejector. The aforementioned ejector ensures liquid circulation between a low pressure receiver (LPR) and the evaporator.

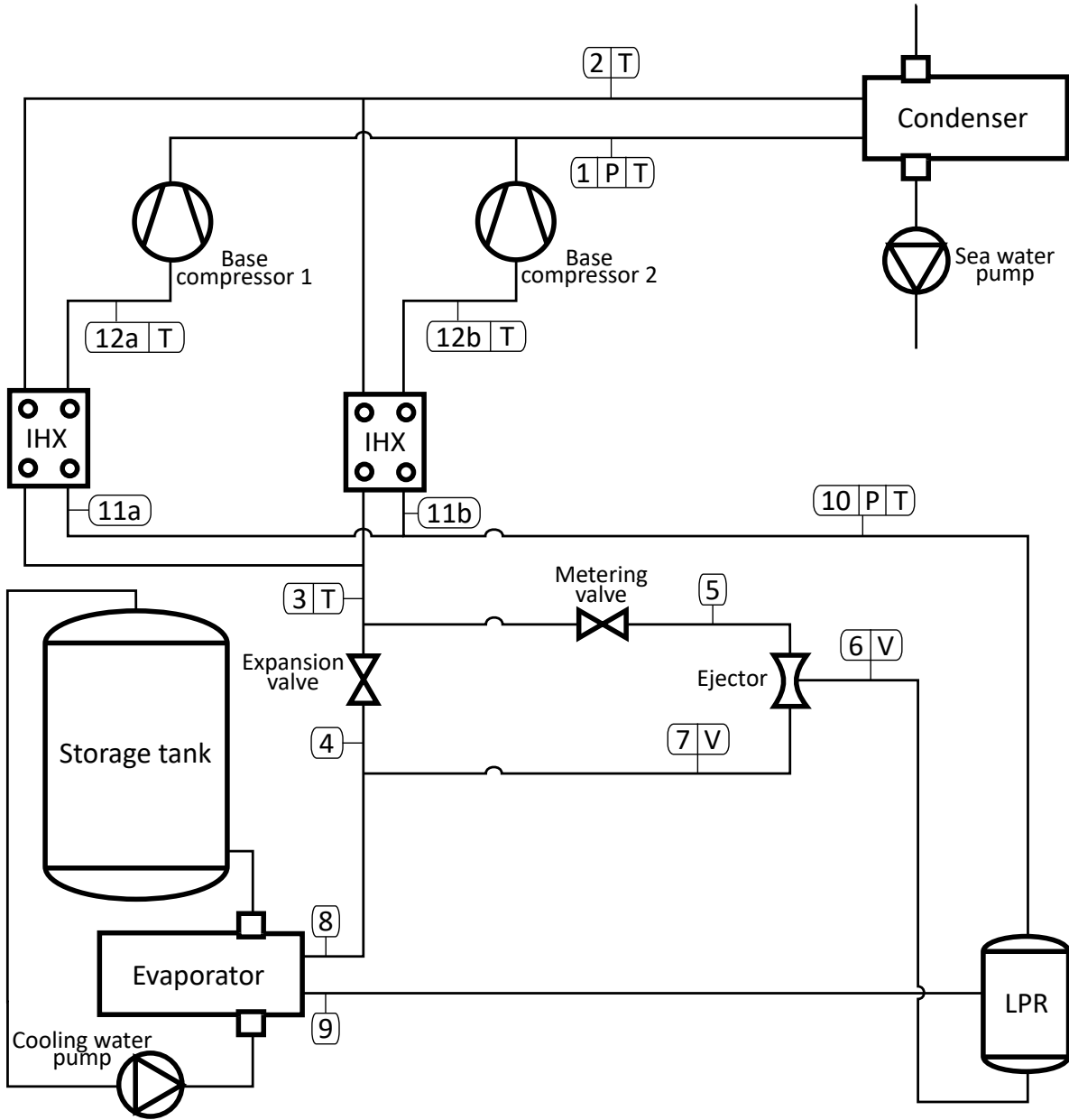

Figure 2.1: Baseline RSW chillers - R744 refrigeration unit installed at fishing vessel operating in Scandinavian conditions.

Liquid ejector utilisation in Baseline RSW

An operation of the mentioned liquid ejector in the analysed RSW installation is focused on the internal circulation of liquid. An energy required for this circulation is recovered from expansion losses on the basis of the ejector work principle. Namely, a flow of subcooled R744 from IHX is divided into two streams in point 3 (see Fig. 2.1). One stream is directly expanded in the throttling valve and second stream flows through the ejector. A basic scheme of the ejector geometry is presented in Fig. 2.2, where a motive nozzle, suction nozzle, pre-mixing chamber, mixer and diffuser are schematically shown. The mentioned high pressure subcooled motive stream is expanded in the motive nozzle and converted to a high velocity flow in the premixing chamber. The expansion process in the motive nozzle reaches pressures below the suction nozzle port, hence a suction phenomena occurs. Next, a pressure of the mixed motive and suction streams is increased in the diffuser. Nevertheless, phenomena of the suction and the pressure lift delivered by the ejector operation are related with each other. Moreover, in a given conditions only one of the mentioned phenomenas can be achieved with high intensity - second becomes simultaneously minor. Thus, obtaining high values of suction stream mass flow rates is related with low values of pressure difference (pressure lifts) between the suction and the outlet port. In the case of the presented RSW installation, the ejector ensures circulation of the liquid where the goal of its operation is given by high mass flow rate of the suction stream. Such an operation results in smaller mass flow trough compressors. On this basis, COP of the system is improved in comparison to the traditional cycle without the ejector.

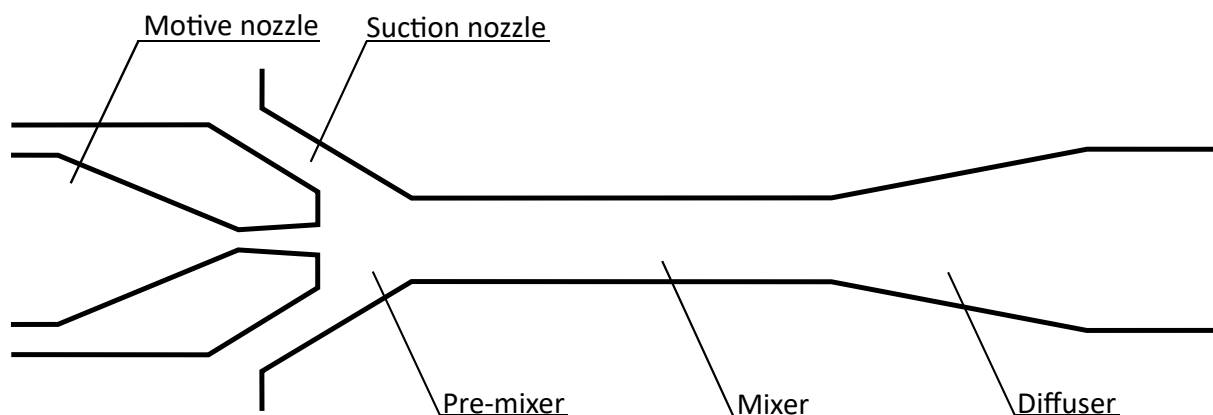

Figure 2.2: Ejector geometry scheme with marked flow sections

Efficiency of ejector operation

The described functions of the ejector in form of the pressure lift or increased suction stream are measured by one overall factor defined as the ejector efficiency. In this study, the ejector efficiency definition (equation 2.1) presented by Elbel and Hrnjak (Elbel and Hrnjak, 2008) was used. This efficiency of the ejector is given as a ratio between recovered work and maximum available work delivered in the motive nozzle. Namely, the numerator is defined as a difference of enthalpies obtained from an isentropic and isenthalpic compression process from the suction nozzle pressure to the ejector outlet pressure. Second part, the nominator is defined similarly but considers expansion process in the motive nozzle:

$$\eta_{EJ} = \chi \cdot \frac{h|_{s=SN,in} p=p_{out} - h_{SN,in}}{h_{MN,in} - h|_{s=MN,in} p=p_{out}} \quad (2.1)$$

where h is the specific enthalpy, subscript s is the specific entropy in the suction nozzle (SN) and the motive nozzle (MN), p is the pressure, and *in* and *out* are the ejector inlets and outlet, respectively. In this definition, parameter χ called mass entrainment ratio (MER) is used (equation 2.2).

$$\chi = \frac{\dot{m}_{SN}}{\dot{m}_{MN}} \quad (2.2)$$

where \dot{m} is the mass flow rate.

2.2 RSW system in high ambient temperatures

Warm waters of Mediterranean and east-Asian region

Motivation of the RSW introduction for hot climates water is concentrated on the system compact sizing and ecological label assigned to the natural refrigerant. However, challenging matter of higher heat rejection temperatures should be solved in order to maintain high performance and economic aspects. Meanwhile, temperature of Mediterranean coast or south-east region of Asia vary from 18°C to 21°C and from 30°C to 33°C, respectively. According to data of Sea Surface Temperature (SST) available in databases of NASA Earth Observation (NEO), waters of the

mentioned east-Asian regions could reach even 35°C (NASA Earth Observation (NEO), 2017). In the region of Mediterranean Sea, temperature difference in comparison to baseline north conditions is smaller. Nevertheless, water temperature reaches up to 23°C (NASA Earth Observation (NEO), 2017). It is worth to notice that even seas located in north conditions, reports rising temperature level. Example is given on the basis of satellite data and analysis focused on the basin of Gulf of Finland (Baltic Sea) (Andrei Tronin, 2017). In this region, average annual SST in 1982 was 6.8°C. Due to significantly visible warming of approximately 0.04K per year, the mentioned value rised to 8.2°C in 2014. However, temperature change was not constant, i.e. in the middle of 80th temperature dropped to 5.0°C just to note significant increase up to 7.3°C in 1989. Moreover, this region was characterised as a special case of inner basin because this trend was not visible in the other regions of Baltic Sea and its coast. On the other hand, in the more global case of Mediterranean Sea, similar increasing trend was described (Sakalli, 2017). Interesting fact of the same as in Gulf of Finland temperature increase rate of 0.4K per decade of the last 30 year was noticed. Moreover, predictions of simulation based on the data from period 1986-2015 showed approximately 5.8K increment of the average SST at the end of XXI century.

Constrains according to fishing vessel construction

Higher temperature difference usually requires increased power consumption and larger sizes of a refrigeration unit. The R744 RSW unit gives solution in the form of overall compact sizing of the installation. However, analysis of power consumption increase and compressors size should allow for further economic analysis of such an implementation to fishing vessels according to available space in the machinery room. Constrained space for system modifications and enlargement could be described as a one of the challenges in such an application.

Analysed modifications of Baseline System

According to the above described space constrains and simultaneously higher power demand, configuration of ejector, flash gas and parallel compression were analysed without modification of the rest of Baseline System installation. In Fig. 2.3, scheme of modified Baseline System model is presented. Intermediate Pressure Receiver (IPR) was introduced with second low-pressure

expansion valve for liquid expansion. Flash gas (red line) is expanded in flash gas valve and next mixed with stream from LPR. Line of parallel compressor (blue line) was separated from flash gas line and directed to main line leading to gas cooler. In order to simulate hot climate conditions, higher temperatures of the heat rejection were assumed. In order to analyse various locations of RSW operation, two temperature levels were taken into consideration. Hence, temperature 21°C and 33°C characteristic for Mediterranean Sea and waters of east Asia were assumed, respectively ([NASA Earth Observation \(NEO\), 2017](#)). In order to investigate influence of each modification, two systems were simulated separately. First system was based on the flash gas expansion (FGV) where whole amount of flash gas was directed to the flash gas valve. Therefore, when FGV mode was tested, parallel compression line was turned off. Second system was based on the parallel compressor utilisation (PC). In this mode, the flash gas valve was closed and whole flash gas stream was sucked by the parallel compressor. However, regulation of the flash gas distribution was taken into account in the form of flash gas distribution factor. This factor was defined as percentage of the expanded flash gas to the whole amount of available flash gas in IPR. Thus, 100% of the flash gas distribution corresponds to FGV system and 0% indicates PC system.

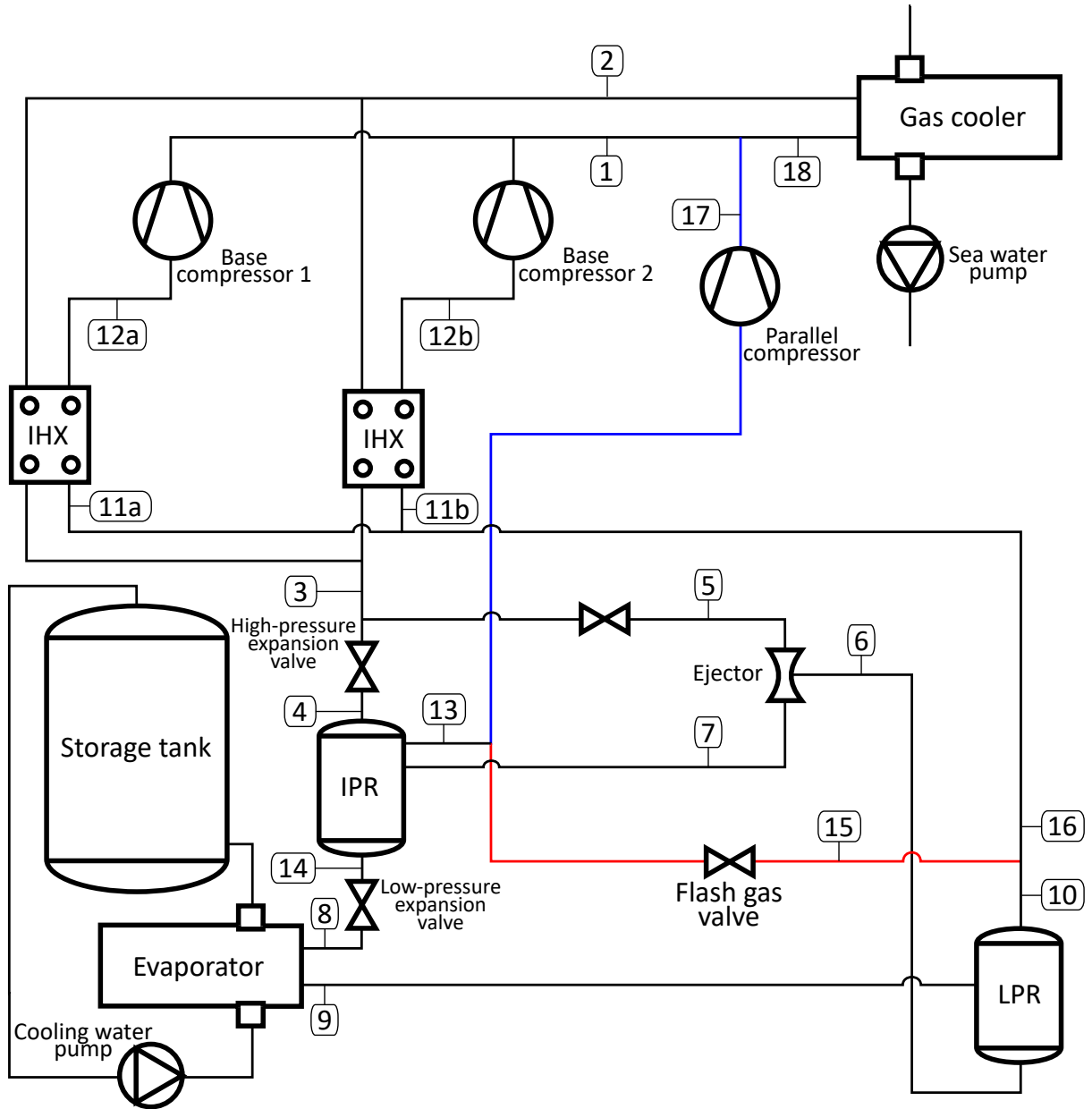

Figure 2.3: Modified RSW installation with introduced additional equipment: IPR (blue), flash gas line (red) and parallel compression line (green).

On the basis of presented FGV and PC installations, next generation of R744 was developed and described in the literature (Hafner et al., 2014). Namely, exchange of the throttling valve into the ejector device was a basis of further cycle improvement, such an installation was presented in Fig. 2.4. Basis of this modification are related with fact that the ejector motive nozzle provides similar results as expansion in throttling valve. However, performance depends on the operating conditions of the system. Hence, proper regulation should be provided in order to obtain high efficiency in various system loads. Moreover, in order to maintain compact sizing and system reliability, ejectors were connected in multi-ejector module forming one compressed device (green frame in Fig. 2.4). Concept of such an approach was delivered in the work of Hafner (Hafner et al., 2014). The same idea was investigated in this study as simulation of separated multi-ejector system (ME). However, some simplifications in modelling of this solution were assumed. Namely, parallel working ejectors were simulated as one device contained in the multi-ejector module. Hence, the ejectors efficiency was described as global efficiency of the vapour and liquid ejectors section. The module work were utilised to pump working fluid from LPR to IPR. Operation of vapour ejectors in the multi-ejector module provides unloading of base compressors by sucking vapour produced in the evaporator to higher pressure of IPR, high enough ejector performance allows for sucking of whole evaporator stream. However, only properly designed ejectors allows for suction of whole evaporator stream by recovering a work obtained from the expansion work. An analysis of these necessary ejector efficiencies were provided as well according to the presented literature review where influence of the ejector efficiency is described as crucial. Having regard the described space constrains, elimination of the base compressor and operation with parallel compressors only would be a perspective solution of RSW implementation.

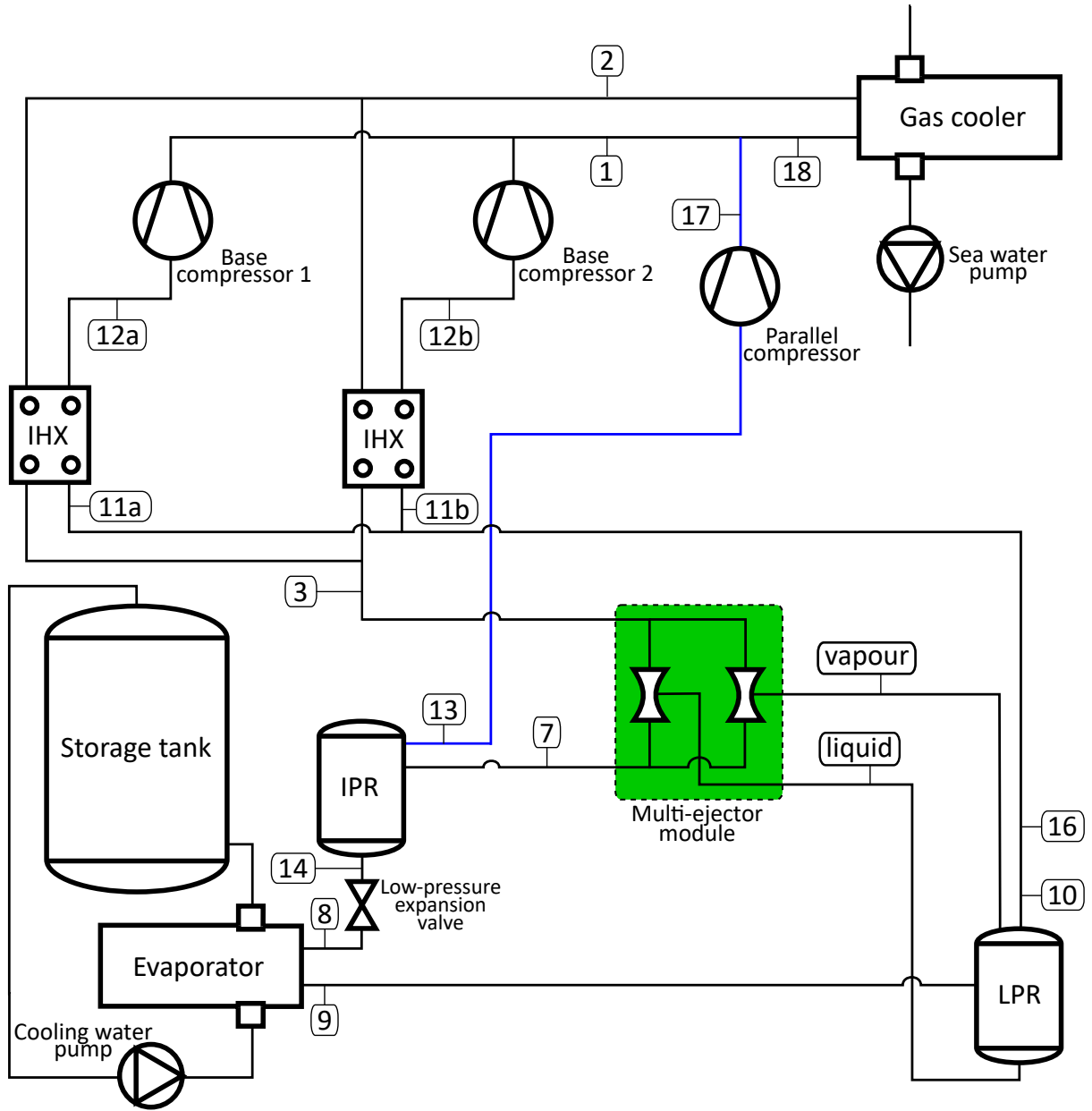

Figure 2.4: Concept of new RSW installation based on the parallel working ejectors contained in multi-ejector module.

2.3 R744 cycle modelling - Baseline and modified configurations

Tool used in the analysis

A system of equations was introduced to Engineering Equation Solver (EES) in order to iteratively solve each model (F-Chart Software, 2016). This tool offers Newton-Raphson method as built-in default solving algorithm for obtaining solution of a set of non-linear equations. Criteria of convergence were set to 10^{-5} for both relative residuals and maximum variable change. Points used in streams formulations were presented in Fig. 2.1 and in Fig. 2.3. A real fluid property library available in the used software was used for determination of thermodynamic parameters in given system point.

Assumptions for simulations of modified systems

According to introduced devices, following assumptions were provided for flash gas, parallel compression and multi-ejector system.

The same compressors manufacturer were used for Baseline System and modified installations. However, different type of compressor was utilised for parallel compression purposes due to higher values of suction pressure. Moreover, on the basis of the auxiliary compressor operating limits, simulated intermediate pressure (IP) range was assumed. Namely, simulated 35 bar in IPR tank was the lowest suction pressure and 45 bar was the highest one.

An isentropic efficiency of the base compressors and the parallel compressor was calculated for each simulation on the basis of the high pressure and the evaporation pressure. The efficiency function involved two mentioned arguments and was obtained on the basis of the data of semi-hermetic transcritical CO₂ compressors delivered by the compressor manufacturer (GEA, 2017).

A heat loss from compressors was assumed to be constant and equal to zero. Hence, temperature at the compressor outlet was obtained on the basis of the enthalpy calculated from isentropic efficiency equation.

On the basis of the compressor manufacturer data, a superheat of gas at the base compressor suction port was assumed as 10 K (GEA, 2017). Equations of IHX energy balances were added as

well where intermediate heat exchanger efficiency was assumed as 100%.

Ejector operation was modelled on the basis of 1-D homogeneous equilibrium model where each section efficiency and pressure in the mixing section are assumed. Efficiencies of the motive nozzle, suction nozzle and diffuser were assumed to be equal to 85%, 80% and 80% for both vapour end liquid ejectors, respectively. The assumed pressure drop between the suction nozzle outlet and the mixer section was equal to 100 kPa. In the Baseline System, pressure lift is utilised only for pressure drop between LPR tank and the evaporator thus estimated ejector efficiency was 1.15%. Further, liquid ejectors in the case of modified systems, were described by constant overall efficiency equal to 15%. This assumption was made for single liquid ejectors as well as liquid ejectors section in multi-ejector module. According to various pressure level in the evaporator and IPR tank, necessary motive stream was calculated.

In the case of ME system, two different approaches were used in computational procedure. According to the large amount of potential recovery work in the case of east-Asian conditions, it was assumed that the ejector work would be enough to suck whole evaporator stream. This means zero power consumption of base compressors. Due to that, necessary efficiency was calculated and further analysed in the results discussion. Evaluation of this efficiency allowed for a statement that this assumption was reasonable. Another approach was provided in the case of Mediterranean climate where potential recovered work was lower. In this case, ejector efficiency was assumed as a function in the range from 20% to 35% on the basis of performance maps presented in the work of Banasiak ([Banasiak et al., 2015](#)). This assumption provided results in the form of evaporator stream distribution for ejector and base compressor suction port, respectively.

Cooling capacity was assumed on the basis of a control terminal data delivered by fishing vessel operator. On the basis of the obtained data, representative evaporator load was estimated on the level of 250 kW and this value was assumed for all simulations of high temperatures of heat rejection. Moreover, in order to evaluate possible implementation and amount of corresponding compressors, range of evaporator load was simulated additionally for the case of most perspective solution. This range was assumed from 250 kW to 455 kW.

According to the liquid circulation ensured by liquid ejectors, vapour quality at the evaporator outlet was assumed as 0.95. Liquid phase of this stream was sucked by the implemented

liquid ejectors from LPR to IPR.

The evaporator pressure was iteratively calculated on the basis of a temperature difference between refrigerant and cooled water. According to cooled water temperature equal to -1°C , the required temperature of refrigerant was calculated as a function of the vapour quality at the evaporator inlet. On the basis of heat transfer coefficient correlation presented in the work of Cheng (Cheng et al., 2006), proper function was approximated in the range of 0.0 and 0.6 of the vapour quality. This function described deterioration of heat transfer conditions with lowering amount of liquid delivered to evaporator. Finally, according to the constant evaporator load necessary temperature difference were calculated.

In order to investigate two mentioned hot climate conditions, two temperatures of heat rejection in the gas cooler were assumed. Moreover, temperature difference between refrigerant and sea water at gas cooler outlet was assumed as equal to 5 K, as in Baseline installation. Hence, 26°C and 38°C refrigerant temperature at the outlet of gas cooler was tested.

Simulation range of high temperature heat rejection

An input data range for simulations of the modified systems were based on the studies presented by Gullo focused on the R744 booster system with a parallel compressor (Gullo et al., 2016b), (Gullo et al., 2016a). That analysis was based on the optimisation of the high pressure, the temperature at the gas cooler outlet, the parallel compressor mass flow rate and the pressure level in IPR. In this study, pressure and temperature range according to Table 2.1 were investigated. Thus, Mediterranean and East-Asian waters were simulated on the basis of two temperature levels after the gas cooler and three pressure levels in IPR were tested. The range of pressure levels in IPR tank was assumed on the basis of operating limits delivered by the compressor manufacturer (GEA, 2017). In the work of Gullo, level of 35 bar was assumed as well. However, those authors assumed this value as constant (Gullo et al., 2016a). In this study three different values were simulated in order to investigate influence of this parameter. Finally, for Mediterranean climate the high pressure level was tested in the range from 66 bar to 115 bar, where 66 bar is a limit for the subcritical mode. In the case of the east-Asian climate, pressure of the compressor outlet was simulated in the range from 75 bar to 115 bar. The described parameters were introduced to the model as a set of boundary conditions for the Baseline System and two modified

cases - FGV and PC. According to work of Banasiak (Banasiak et al., 2015), Haida (Haida et al., 2016) and Bodys (Bodys et al., 2017), IP levels for ME systems operating with vapour ejectors were assumed regarding multi-ejector module operating range. Hence, IP levels were different than for FGV and PC, namely 34 bar, 36 bar and 38 bar.

Table 2.1: Set of input data for simulations of high temperature heat rejection in Mediterranean and east-Asian climate.

| Climate | Mediterranean | east-Asian |
|-----------------------|--------------------------------|--------------------------------|
| $t_2, ^\circ\text{C}$ | 26 | 38 |
| p_{ipr}, bar | 35, 40, 45 (34, 36, 38 for ME) | 35, 40, 45 (34, 36, 38 for ME) |
| p_1, bar | 66,...,115 | 75,...,115 |

Chapter 3

Results discussion of Baseline and modified RSW systems

3.1 RSW installation in northern Norwegian conditions

Baseline System was simulated according to the measurement points of the actual system operation. Set of input data and obtained system COP for Baseline System simulations in Scandinavian conditions were presented in Table 3.1. System points were described in Fig. 2.1, C1 and C2 denotes frequency set of compressors 1 and 2 respectively. \dot{m}_{SUC} denotes amount of liquid sucked by ejector in given system state. Evaporator load is determined by Q_{EVAP} . High and low pressure side of cycle are given by p_c and p_o respectively. Five different system states were simulated on the basis of introduced ejector suction mass flow rate. The first three states represent full load state, while the other two were related with the part-load operation. According to the lack of the motive nozzle measurement, an assumption of constant MER value was given in order to calculate the motive stream. The MER value was assumed as 1.5 on the basis of the ejector design process data delivered by SINTEF Energy Research. The obtained system COP was on the level from 4.71 to 9.25. The increments were related with lowering condensation pressure p_c and increasing suction mass flow rate \dot{m}_{SUC} . Moreover, relation between condensing pressure p_c and lowering temperature after condenser t_2 was maintained. High values of COP provided wide perspective of further areas of implementation.

Table 3.1: Input data and for Baseline System and obtained COP for actual RSW installation operating at northern Norwegian coast.

| C1 | C2 | p_c | t_1 | t_2 | t_3 | Q_{EVAP} | \dot{m}_{SUC} | p_o | t_{11} | t_{12} | COP |
|----|----|-------|--------------------|--------------------|--------------------|------------|-----------------|-------|--------------------|--------------------|------|
| Hz | Hz | bar | $^{\circ}\text{C}$ | $^{\circ}\text{C}$ | $^{\circ}\text{C}$ | kW | kg/s | bar | $^{\circ}\text{C}$ | $^{\circ}\text{C}$ | - |
| 70 | 70 | 55.3 | 77.3 | 15.9 | 1.8 | 234 | 0.005 | 28.3 | -6.1 | 14.0 | 4.71 |
| 70 | 70 | 56.3 | 70.9 | 16.5 | 6.9 | 353 | 0.082 | 30.9 | -3.2 | 14.9 | 5.34 |
| 0 | 60 | 50.0 | 58.9 | 12.2 | 4.8 | 139 | 0.095 | 28.2 | -6.2 | 1.9 | 5.75 |
| 35 | 35 | 50.3 | 64.7 | 12.5 | 1.1 | 144 | 0.138 | 28.3 | -6.2 | 12.6 | 7.65 |
| 0 | 50 | 48.4 | 46.9 | 10.7 | 4.4 | 106 | 0.112 | 28.4 | -6.0 | 1.8 | 9.25 |

3.2 Proposed modifications for hot climates applications

Systems performance in Mediterranean climate

Baseline System as well as the modified flash gas valve, parallel compression and multi-ejector systems were tested in the mentioned Mediterranean and East-Asian climate. The results from the first group of simulations (Mediterranean) are presented in Fig. 3.1 where relation between COP and the high pressure is given. The Baseline System is described by a black curve. Results from FGV, PC and ME are described by group of red, blue and green curves, respectively. Additionally, value of IP (bar) is indicated by a number after the system determination. The same manner of data presentation was used in further analysis. According to results presented in Fig. 3.1, the highest COP of 3.22 is related to the ME system and 34 bar in IPR, namely in case ME-34. Increasing pressure in IPR is deteriorating COP of ME system what is related with too small amount of recovered work in the ejector. Having regard higher motive pressure (gas cooler pressure), ratio of COP decrement is becoming smaller. An explanation is located in higher potential of work recovery available in the ejector in the region of higher pressures. Nevertheless, in the case of highest COP, efficiency of ME is on only slightly lower level than Baseline System in favourable Scandinavian conditions. Similar situation is related with FGV and PC system. Namely, the lowest pressure in IPR is provided highest performance what is based on the increased cooling capacity. Having regard FGV and PC system, the obtained COP is on lower level than ME systems. For the lowest pressure related with operating limits of subcritical mode, PC and FGV ensures COP of 2.98 and 2.66 respectively. In every of the simulated cases COP is decreasing with increasing high pressure. Hence, in the conditions of Mediterranean climate, increased power consumption in higher pressure operation is lower than the obtained improve-

ment of cooling capacity. Due to this, lowest possible level of high pressure should be ensured for optimal performance.

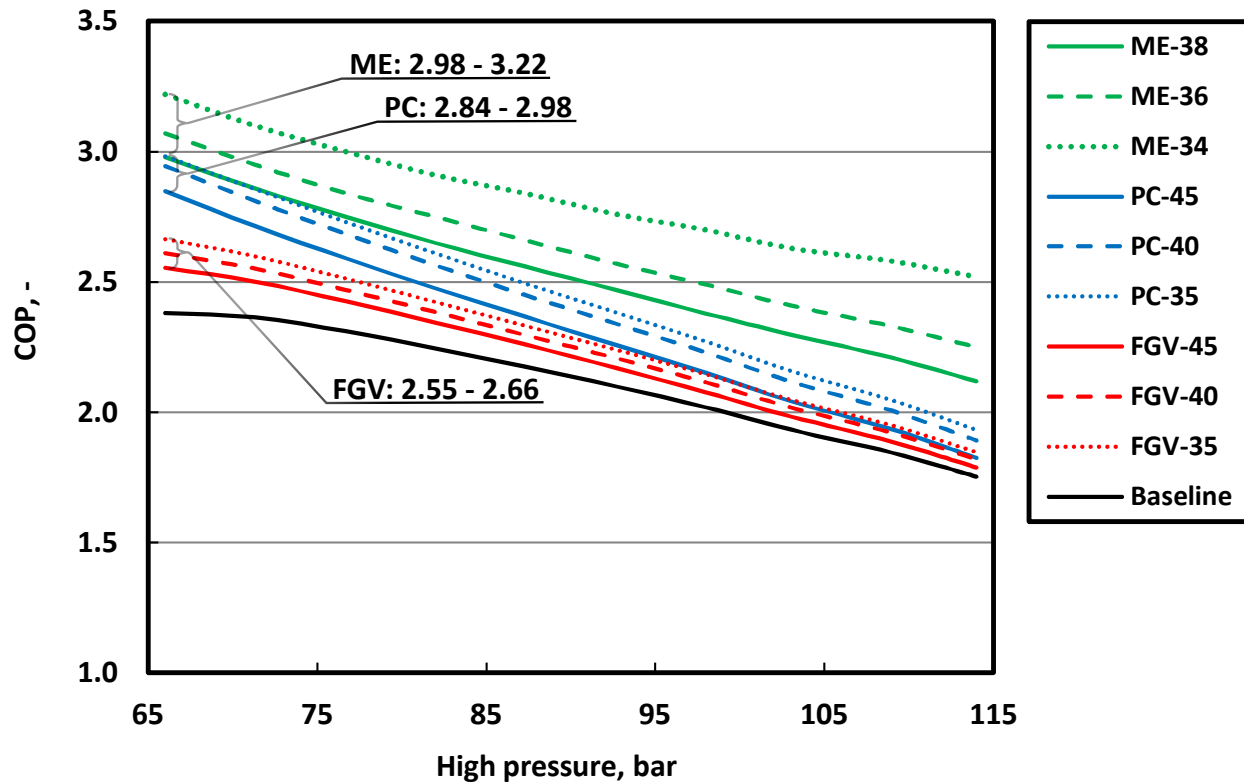

Figure 3.1: COP of the Baseline System and the modified cases are presented in the function of high pressure from simulations performed for **Mediterranean climate**.

System performance in East-Asian climate

Simulation cases of the heat rejection temperature characteristic for East-Asian waters provided results presented in Fig. 3.2, the same manner of case identification was used as in Fig. 3.1. However, optimum pressure of each system was marked by vertical line with corresponding pressure value. First of all, a wide range of optimum operation should be noticed due to small changes in performance near optimum pressure. However, significant differences are visible between each system performance. Namely, most perspective solution is related with ME system where maximum of COP is equal to 2.58 for 94.6 bar of high pressure. The optimum pressure in IPR is different than in the lower temperatures of heat rejection, higher ME system performance is obtained in the case of the highest pressure in IPR tank. This relation is directly connected

with more and more efficient operation of the multi-ejector module which is delivering sucked vapour to higher pressure. Simultaneously, higher pressure of parallel compressor suction port directly results in lower power consumption. However, difference between investigated IP is on the level of 5% - the highest COP of ME-36 is equal to 2.46 while mentioned ME-38 is 2.58. Moreover, differences between system COP are more visible for various IP of ME system than in PC and FGV. The latter ones seems to be much less dependent on pressure in IPR. However, small differences occurs - medium pressure in the case of PC ensured slightly higher COP (1.935) than highest IP equal to (1.927). Increasing high pressure is delivering quite visible better performance of mentioned 40 bar of IP what is related with balance between recovered work and favourable conditions of parallel compressor work. In the case of FGV, even smaller difference is visible, other trend is obtained as well. FGV system should operate in the lowest IP in all the range in order to obtain highest performance with the COP of 1.651. Having on regard optimum high pressure, slightly different values are obtained for each system what is related with other factors of crucial impact on the system COP. In the case of ME, it is ejectors efficiency and parallel compressor performance. In the case of PC and FGV systems, final results was created by optimum point between parallel compressor efficiency and amount of gas in IPR tank. Computations of PC system resulted in the highest COP for pressure 92.5 bar in IPR. Concerning series of curves related with FGV system higher pressure value was obtained as optimal - at approximately 97.3 bar. Global trend of every simulated system can be described as similar. However, modified systems are characterised by significant COP difference in comparison between each other, especially in the range of optimal pressures after compressors. Moreover, different pressures for optimal operation should be ensured for each case, while PC optimum should be reached for the lowest pressure in comparison to the other systems.

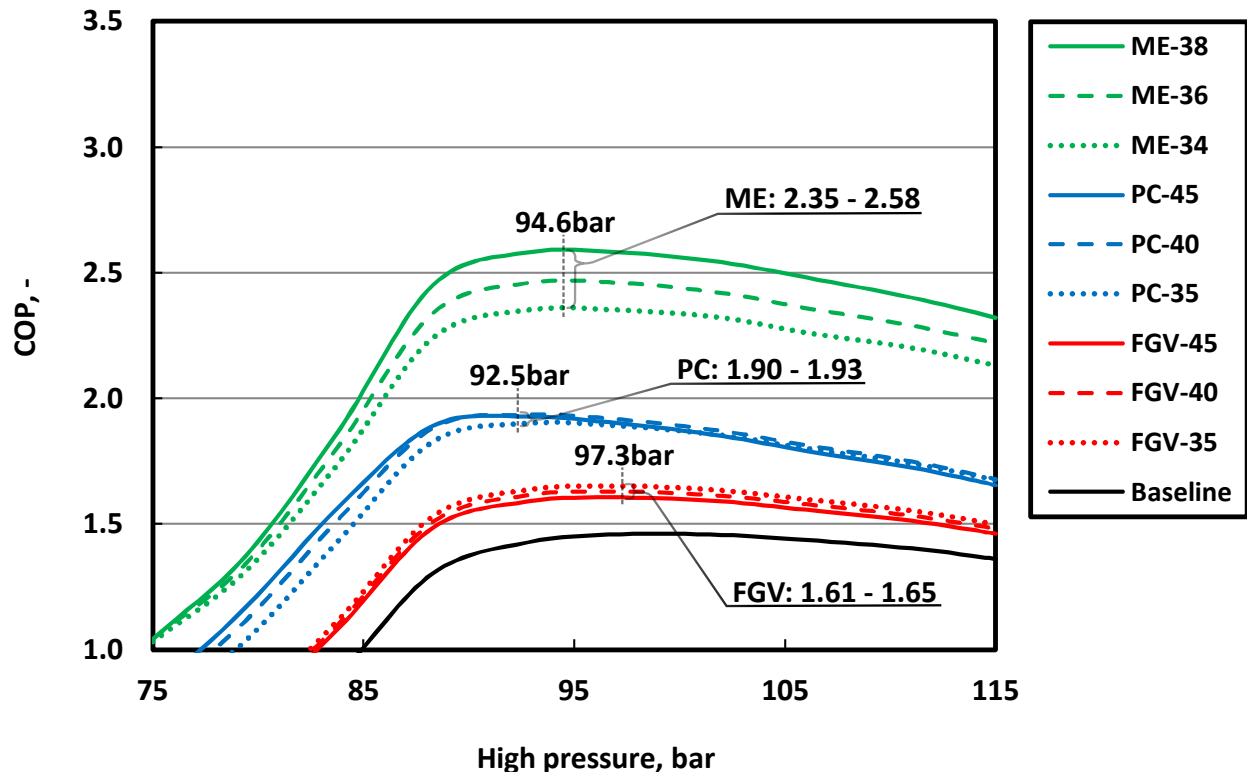

Figure 3.2: COP of the Baseline System and the modified cases are presented in the function of high pressure from simulations performed for **East-Asian climate**.

Performance improvement of the modified installations for operation in Mediterranean climate

On the basis of the mentioned differences between systems COP, proper comparison data was provided in order to illustrate improvement level between every system. Namely, the performance improvement of the modified systems in comparison to Baseline System was presented in the form of percentage COP increment in Fig. 3.3 for 26°C (Mediterranean) of the heat rejection temperature. According to Fig. 3.3, the COP improvement is lowering with increasing pressure - exception is related with the ME system. For the highest pressures, the COP improvement of ME system is higher than for the lowest pressure. This can be explained on the basis of better multi-ejector module performance. Nevertheless, the highest COP of the system is still related with the lowest pressure available in the subcritical mode. Hence, the highest improvement is simultaneously related with the highest COP value. Possible improvement related with ME system is on the level from 26% up to 37% in comparison to Baseline System. This significant improvement is mostly based on the recovery of expansion losses and utilisation of higher efficiency of the parallel compressor that unloads the base compressor. In the case of PC and FGV system, significantly lower improvement could be obtained. The improvement range of 19% to 26% is ensured by PC operation. Here, only benefits from utilisation of the parallel compressor are visible. The lowest improvement is shown by FGV system. In this mode, improvement is related only with higher amount of liquid phase at the evaporator inlet. As a result, maximum available improvement is on the level of 12% in comparison to a simple one stage system. As it was mentioned, having on regard data in Fig. 3.2 and Fig. 3.3, the same pressure corresponds to the highest COP of the system and to the highest COP improvement in comparison to Baseline System (with exception of ME system). Due to this, both maximum of economic and efficiency improvement are obtained for the same pressure. Moreover, trend of these relations is the same - decreasing with increasing high pressure. Therefore, in analysed systems, operation at the lowest possible pressure in subcritical mode is the most efficient solution in Mediterranean climate.

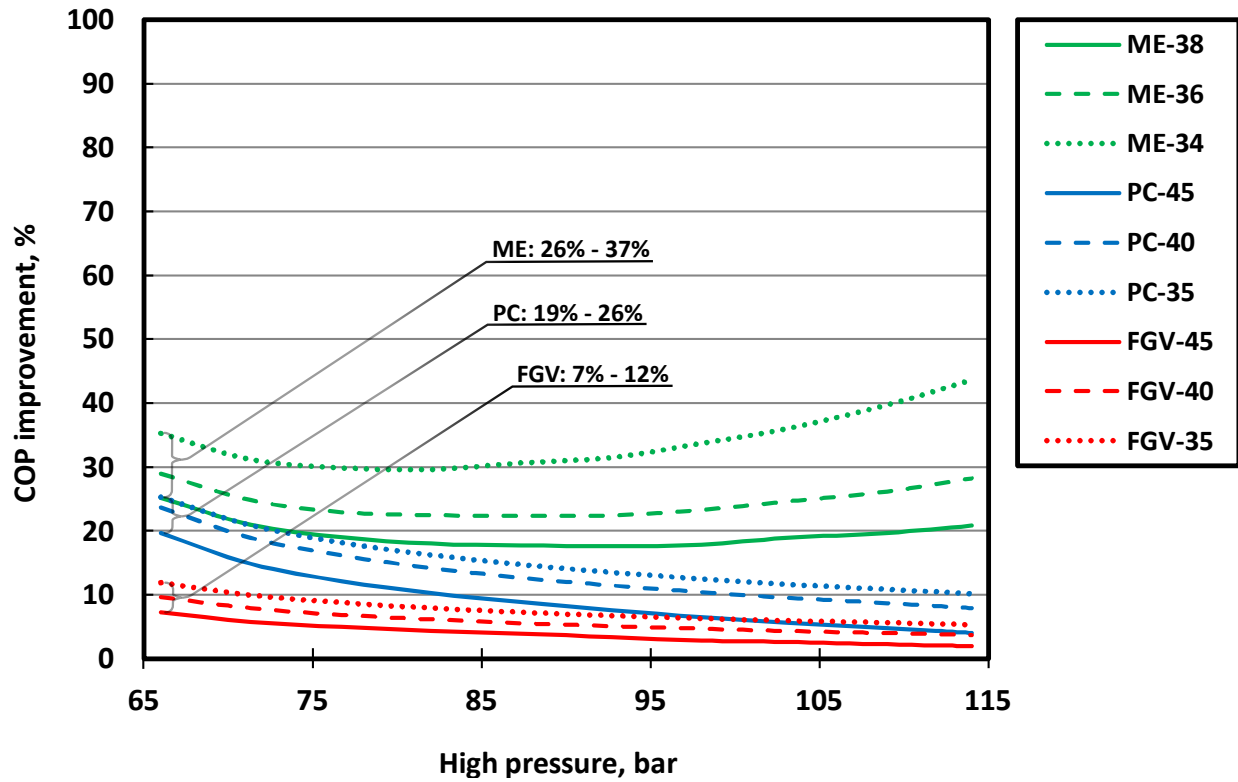

Figure 3.3: Relative COP improvement (%) of the modified systems in comparison to the Base-line System operating in **Mediterranean climate**.

Performance improvement of the modified installations for operation in East-Asian climate

According to the COP improvement for East-Asian climate simulations, significant difference in the trend is visible in Fig. 3.4 when compared to Mediterranean climate (see Fig. 3.3). First of all, the highest improvement was obtained in the range of pressure where COP value is relatively small - for the lowest pressures. This is due to very low efficiency of Baseline System which is affected by the huge expansion losses and a reduced cooling capacity when operating at the pressure close to the critical value. Moreover, point of the optimal operation (marked by vertical lines with corresponding pressure, see Fig. 3.2) of every system is located in the range from approximately 90 bar to 100 bar. Due to this, scale on the vertical axis of graph in Fig. 3.4 was limited. Hence, finally obtained COP improvement is marked in Fig. 3.4 according to optimal high pressure from Fig. 3.2. Next, the COP improvement of investigated systems for the optimum pressure are different than the improvement level in the case of Mediterranean climate. ME system reaches improvement of maximum 78% when operating with the highest pressure lift delivered by multi-ejector module. In hypothetic inappropriate construction of this device and lower pressure lift, ME improvement would be lowered to the level of 63%. Improvement of the PC solution is characterised by higher values than in Mediterranean climate. Moreover, very small difference is visible between analysed IP levels. For optimum pressure, PC operation provides from 33% to 36% of improvement for 35 bar and 40 bar in IPR, respectively. In higher pressures, PC resulted even in better performance with lower pressure in IPR what is related with decreasing superiority of benefits of high efficiency operation of the parallel compressor. Having on regard the least efficient FGV operation in its optimum pressure, improvement is on the level of 10%, while the highest value is 13%. Hence, the COP improvement is higher in the East-Asian climate than in Mediterranean. On the other hand, in both climates the most perspective implementation is related with ME system. Despite of lower costs of investment, simpler solutions as FGV and PC might be disqualified for fishing vessel application. This is due to large amount of power consumption and consequently space requirement for other compressors what was discussed in next sections.

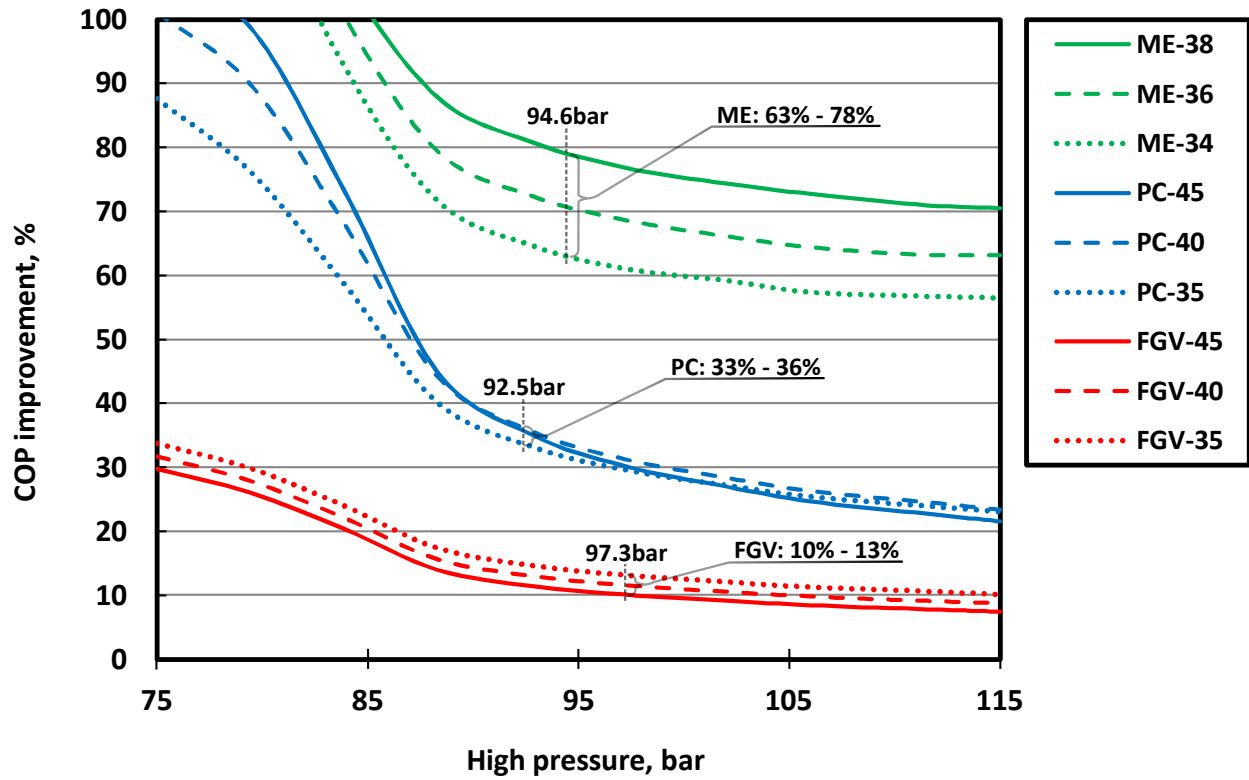

Figure 3.4: Relative COP improvement (%) of the modified systems in comparison to the Base-line System operating in **East-Asian climate**.

3.3 System modifications according to power demand increment

Modification requirements and limits of components in Baseline System

According to the paper goals, possible modifications were analysed in the light of a restricted space volume in the machinery room of a fishing vessel. From this point of view, the most demanding system would be ME and PC due to additional compressor implementation. However, in the higher ambient conditions (East-Asian), in the ME only parallel compressors could be used what will be explained in further discussion. Moreover, having on regard the obtained COP improvements of modified systems, ME was assigned as the most perspective solution. Nevertheless, due to higher ambient temperature than in Scandinavian conditions, higher power consumption is mostly expected. In Baseline System, two base compressors characterised by a maximum power of 44 kW are used (GEA, 2017). The maximum power of available transcritical CO₂ compressors of used manufacturer is approximately 58.3kW (GEA, 2017). In order to avoid introducing third compressor to fishing vessel machinery room, two compressors of maximum power demand below mentioned 58.3 kW should be used for PC purposes. In order to evaluate this possibilities, analysis of compressors power and corresponding system efficiency was provided.

Power requirements for operation in Mediterranean climate

Requirements of compressors power for Mediterranean and east-Asian climate are presented in Fig. 3.5. Results of the most efficient system configurations for Mediterranean climate were presented in Fig. 3.5. Namely, systems with the lowest pressure in the IPR. Total compressor power of FGV was presented as a function of high pressure by red line. ME (green) and PC (blue) system were presented by solid, dashed and dotted line for a total power consumption, base load compressors and parallel compressors, respectively. The same manner of case determination was used graph presented in Fig. 3.6. According to Fig. 3.5, point of the optimal operation is related with the lowest pressure, where the power consumption is on the lowest level. Operation of FGV system can be obtained by two compressors of similar maximum power in order to obtain approximately 94 kW of total power in optimal (lowest) high pressure. Moreover, total work of

each compressor could be on the level below 58.3 kW up to approximately 90 bar. In the case of more advanced solutions, lower power consumption is presented. However, despite of this, one additional compressor should be delivered for the PC solution to cover parallel compression purposes. This is caused by the very low consumption of parallel compressor and high, increasing power of the base compressors section which exceeds assumed maximum power of one compressor - 58.3 kW. Meanwhile, the parallel compression is characterised by maximum power of 14 kW due to almost constant load within the tested pressure range. Thus, the reasons are based on the to high power demand of the base compressors section. Any regulation of flash gas distribution would result in serious deterioration of the system performance, practically leading to the same COP level as in the FGV. Hence, in the Mediterranean climate, the same set of compressors can be used as in the Baseline System only in the case of the FGV and ME configuration. Nevertheless, low COP of the FGV system should disqualify such an implementation. Difference in required power of FGV and ME is significant and only ME system should be considered. In the case of the ME system, similar compressor for base and parallel purposes should be used with a proper modification of piping system. For the lowest pressure the base compressor of the ME system demand approximately 44 kW, what is exactly maximum power of one compressor installed in Baseline System. Thus, slightly more powerful compressor should be used for the base compression purposes. Parallel compressors section requires lower power than the base ME compressors. Namely, it is at the level of 34 kW. Finally, the required maximum power of compressors installed in Baseline System would be enough for Mediterranean climate while the most efficient operation would be ensured by ME system.

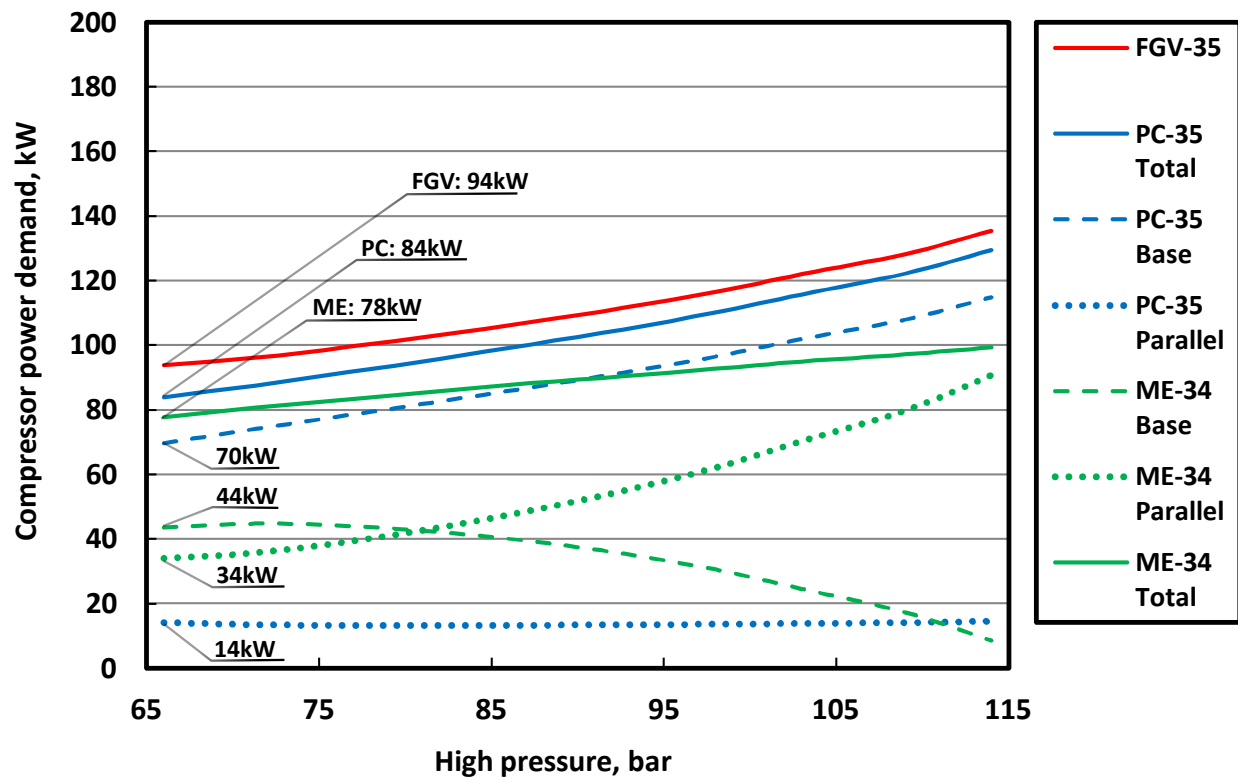

Figure 3.5: Compressors power demand of the modified systems characterised by the highest COP improvement in **Mediterranean climate**.

Power requirements for operation in east-Asian climate

The power consumption in East-Asian climate is characterised by definitely higher values than for Mediterranean climate. Moreover, non-linear trend is presented in Fig. 3.6, where the results of the power consumption are described in the same manner as in Fig. 3.5. Firstly, significantly higher power consumption was obtained in the case of FGV and PC. In comparison with power consumption in Mediterranean climate, approximately 60% and 53% more energy should be delivered for FGV and PC operating in East-Asian climate. In the same comparison, ME system operating in East-Asian conditions needs only 24% more power. Due to the mentioned necessary power, in the case of FGV system could not operate without an additional third compressor because FGV total power (151 kW) is significantly higher than 115 kW corresponding to the two compressors. The base compressors section of the PC system would be covered by two compressors. However, very narrow buffer of additional cooling capacity would be ensured. This is due to that, the base load compressors would operate very close to its maximum power supply. Namely, the mentioned maximum power of two compressors is approximately 115 kW while the base compressors of PC system would operate at the level of 106 kW. Any significant additional cooling load would be impossible to obtain in such an installation. Moreover, parallel compression should be satisfied by additional third compressor of 23 kW. Thus, in this conditions FGV and PC system would require one additional compressor for each of the system. Moreover, for lower pressure range, the parallel compressor load exceeds its maximum power supply, thus even two additional compressor might be required if system operates improperly. Finally, the only solution without necessity of additional third compressor is ME. In this approach, the base load compressor is totally unloaded by multi-ejector module. Hence, the entire stream from evaporator could be delivered to higher pressure applying the ejectors as a booster for the parallel compressors. The required power of ME would be at the level of 97 kW. The obtained low power consumption is based on the large amount of potential work recovery, higher pressure at parallel compressors suction port and its high isentropic efficiency based on the low pressure ratio. Moreover, partially increased cooling capacity is ensured by liquid ejectors. As a final result, only two compressors of 58.3 kW would be enough to ensure operation of the R744 refrigeration unit in East-Asian climate.

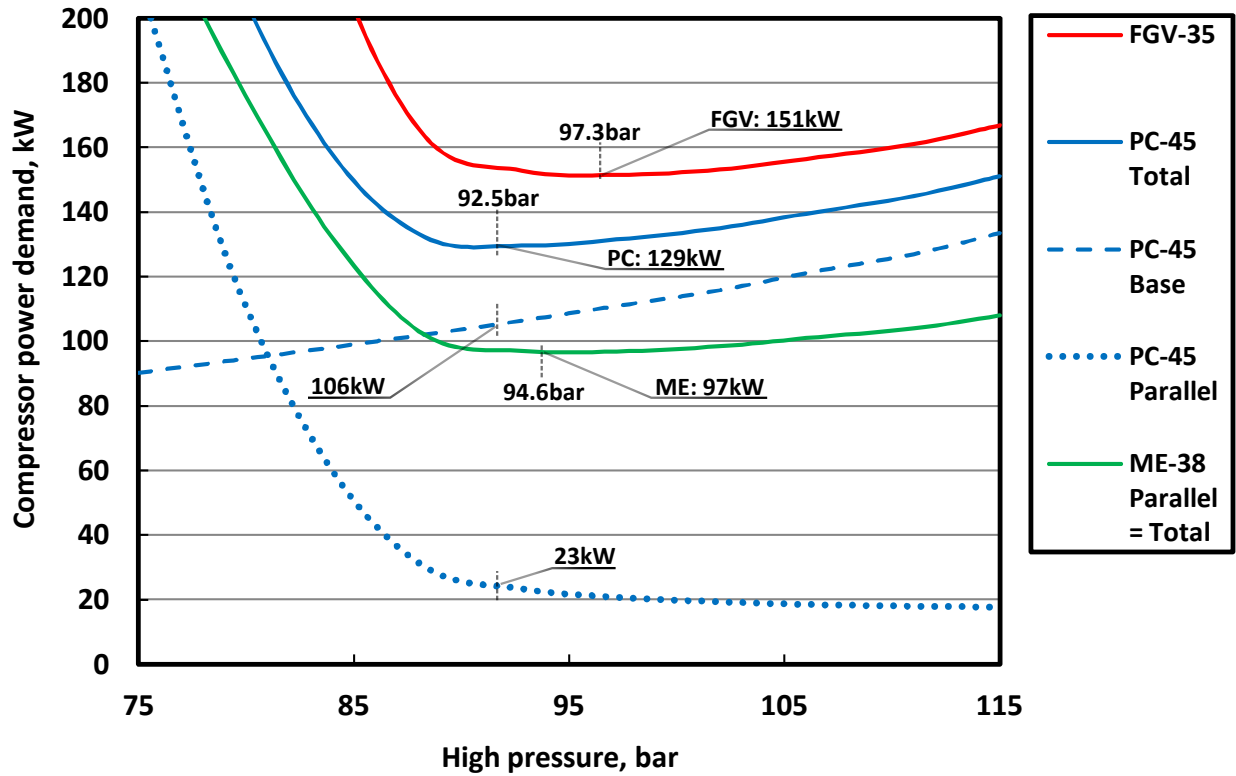

Figure 3.6: Compressors power demand of the modified systems characterised by the highest COP improvement in East-Asian climate.

Ejector efficiency requirements in East-Asian climate

In the case of east-Asian climate, the system was modelled with utilisation of parallel compressors only. Consequently, whole evaporator stream was sucked by the vapours ejectors in multi-ejector module. Due to this, necessary efficiency of the vapour ejectors section to operate with given conditions were calculated. In Fig. 3.7, the ejector efficiency obtained for each pressure in IPR was presented. According to COP data presented in Fig. 3.2, optimum pressure were marked in order to point necessary efficiency of the vapour ejectors section. Firstly, significant difference between efficiencies is visible for higher pressures, including range of optimum pressure. Having regard data presented in the literature, efficiency of vapours ejectors on the level of 35% could be estimated as highest reported (Banasiak et al., 2015). Therefore, operation at 36 bar of pressure in IPR tank could be stated as possible at this moment of the vapour ejectors development. Nevertheless, in case of the highest IP significant improvement of ejectors technology should be provided in order to reach the level of 52% efficiency. Possibility of significant improvement of efficiency up to the level of 45% was described in the previous work of author of this study (Bodys et al., 2017). On the other hand, as was discussed, COP difference between ME-36 and ME-38 is on the level of 5%. Hence, performance of the ME-36 is still on the high level which is comparable to ME-38.

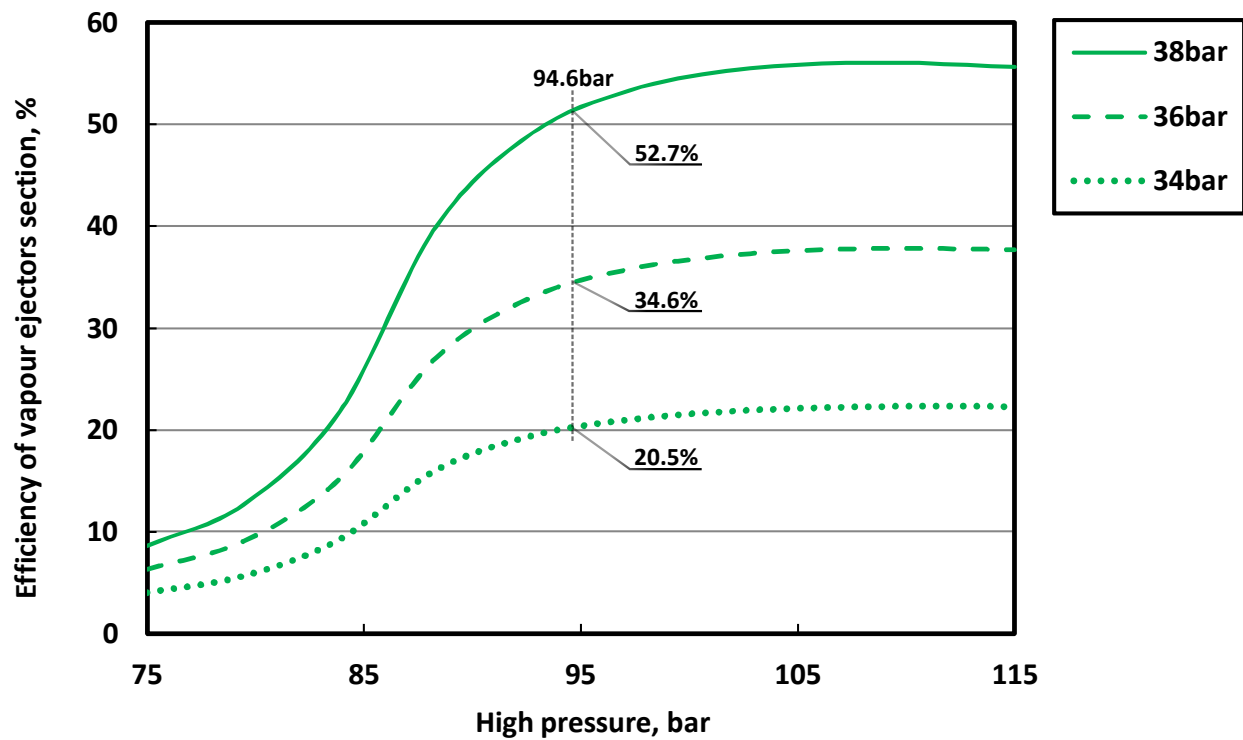

Figure 3.7: The required efficiency of the vapour ejectors section in the multi-ejector module for each of the investigated pressures in IPR.

Available cooling load in the function of installed compressors power

The assumed cooling load of 250 kW could be described as a representative for Scandinavian operation. Having regard various amount and kind of catch, different evaporator loads might be obtained. Necessary power for ME system in function of the evaporator load was presented in Fig. 3.8. The simulations were performed for the optimum operation in east-Asian conditions. The maximum power of one compressor was assumed on the basis of the manufacturer data (GEA, 2017). According to the limit of two compressors utilisation, the evaporator load in the range from 272 kW to 298 kW could be obtained depending on IP which is directly related with the ejectors efficiency. This range is wider for higher capacities when differences between operation with higher or lower IPR is more significant. On the other hand, three compressors could deliver significantly higher evaporator load than two compressors. Namely, in the least efficient scenario of 34 bar, available cooling capacity would be on the level of approximately 412 kW. Hence, in installation equipped in third compressor, ensures about 52% of additional available evaporator load. Moreover, in the case of the mentioned high efficiency multi-ejector module and 38 bar of IP, this increment of the available evaporator load reaches even 67%.

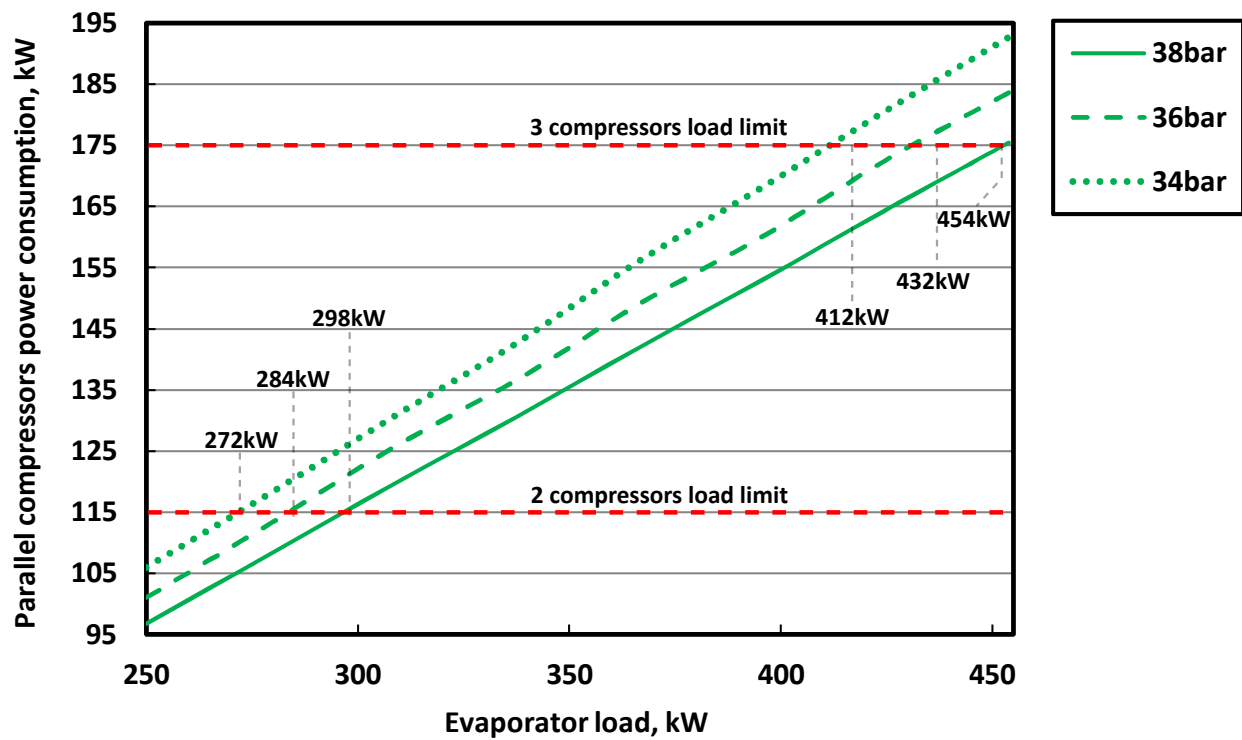

Figure 3.8: Necessary power of parallel compressors of ME system operating at the optimum pressure in the function of evaporator load.

Chapter 4

Conclusions and further work

4.1 Performance analysis in various ambient conditions of three proposed system modifications

High efficiency operation in Norway

A mathematical model of the classic R744 refrigeration unit equipped with the liquid ejector was developed and utilised in order to evaluate performance of the installation operating at fishing vessel in Scandinavian conditions. Equations of mathematical models were numerically solved according to used Engineering Equation Solver and implemented input data delivered by measurement equipment installed in the actual installation. High efficiency of the installation was obtained according to low temperature of heat rejection and implemented liquid ejector operation.

Mediterranean and East-Asian climate operation -requirements and constrains of fishing vessel

Due to green label marked natural refrigerant and compact sizing of the installation, implementation at higher ambient conditions were tested according to perspective introduction to markets related with fishing in warm climates. Hence, additional models of the flash gas valve, the parallel compression and the multi-ejector system were developed. On the basis of data ob-

tained from NASA Earth Observatory online databases ([NASA Earth Observation \(NEO\), 2017](#)), Mediterranean and East-Asian sea waters were simulated as the heat rejection temperature of 21°C and 32°C, respectively. According to the thermodynamic characteristic of R744, system modifications were necessary to maintain high performance of the system. Nevertheless, space limitations of the fishing vessel machinery room required additional consideration of introduced equipment related with modified systems. Hence, more advanced cycles were examined in the light of system performance as well as additional equipment introduced to the fishing vessel machinery room.

Performance characteristic in Mediterranean climate

The analysis of the systems operation in Mediterranean climate showed significant improvement in comparison to the classical cycle. The highest improvement should be delivered by ME cycle starting from 26% up to 37% which corresponds to COP of 3.22. PC and FGV solution should ensure COP of 2.98 and 2.68, respectively. Overall trend in Mediterranean climate shows that the most efficient operation is related with the lowest possible pressure of condensation - according to subcritical mode. Consequently, maintaining of lower pressure in IPR tank resulted in higher cycle efficiency. Further, the assumed temperature before expansion device equal to 26°C results in high expansion losses, nevertheless this amount is not enough to make significant difference between ME and the rest of examined systems.

Performance characteristic in East-Asian climate

Simulations of East-Asian conditions resulted in the other trend of the COP distribution. First of all, significant differences were presented between each of tested configurations. Generally, in the case of East-Asian water, the optimal pressure in IPR is related with higher values. FGV was an exception when slightly better COP was obtained for lower IP. Expectations of better performance in higher, supercritical pressures were confirmed in every case. Again, most perspective solution was ME where the maximum obtained COP was 2.58. For lower IP, this system resulted in COP of 2.46 and 2.35, respectively. In investigated configurations, the optimal high pressure was around 95 bar. Moreover range of high performance could be described as relatively wide

according to high pressure value. Such a characteristic should provide advantages in regulation and automation area. However, according to the obtained results, the ME solution should be stated as the best approach for high ambient temperatures - according to the system performance as well as equipment space requirements.

4.2 Modification requirements according to the space constraints at the fishing vessel

R744 cycle operation in Mediterranean climate

According to the discussed performance results, significant advantages were related with the most efficient ME configuration. However, there are more benefits related with this approach. Moreover, some of FGV and PC modification features would disqualify these solutions in analysed application. Namely, according to the presented power requirement, in the Mediterranean climate ME would be operating with only two compressors of similar maximum input power. Moreover, these compressor could be the same as in the Baseline installation operating in the Scandinavian conditions. Hence, the application of ME allowed for obtaining the assumed cooling capacity without additional compressor - moreover in higher ambient conditions. Meanwhile, FGV would need more powerful compressors than Baseline case - nevertheless a third compressor would not be necessary. Another situation is related with PC solution where two compressors from Baseline installation would be utilised but only with additional one auxiliary compressor for parallel compression purposes.

R744 cycle operation in East-Asian climate

East-Asian, more demanding conditions, showed only one proper solution in the form of ME. In this case, as in Mediterranean climate, third compressor is not necessary. However, two compressors of higher power input should be delivered for parallel compression. In the case of FGV and PC, both systems need the third compressor in order to deliver the assumed capacity. In the case of the PC, very narrow buffer of additional power would be ensured in the light of base compressors delivered by the same manufacturer. Hence, in the case of East-Asian fishing vessel, the

most perspective solution is ME due to highest performance but as well as no additional space required in the comparison to the installation operating in favourable Scandinavian conditions.

Efficiency of vapour ejectors section in multi-ejector module

In the case of the analysed highest temperatures of the heat rejection, results in the form of necessary vapour ejectors section efficiency were obtained. According to the operation with parallel compressors only, the whole stream from evaporator was sucked by vapour ejectors. On this basis, necessary efficiency of this device was obtained. In the case of lower efficiency than obtained, one base compressor would be needed. Meanwhile, according to the literature data, ejectors of the demanded efficiency can be designed for two of three investigated pressures in IP - 34 bar and 36 bar. In order to obtain higher system efficiency on the basis of IP of 38 bar, improved vapour ejectors would be necessary. However, this efficiency increment could be described as relatively high what might be called as a ejectors of the next generation. On the other hand, available improvement areas were already indicated in the literature.

Evaporator load limits depending on installed compressors power

Different character of operation related with logistic factors can result in the various evaporator load of the refrigeration unit at a fishing vessel. The results showed good perspective for higher cooling capacities according to the implementation of the third compressor. Such an installation could provide almost twice cooling capacity than installation operating with the two compressors. According to Scandinavian conditions, the mentioned power of 450 kW were out of the operating range. Nevertheless, higher ambient conditions and different character of fishing process might involved such high evaporator loads. Hence, the third compressor would be necessary in certain special conditions but this third power unit ensure very high buffer of additional cooling capacity.

4.3 Further work

More advanced model implementation

The improvement of the simulation model should be considered in order to evaluate system work in a part load conditions as well as for an introduction of more detailed model of the evaporator. Moreover, transient operation of described system should be simulated in order to evaluate influence of increasing load of evaporator due to catch introduced to the storage tank. Significant influence of the ejector section were confirmed by the authors in available literature. Hence, advanced modelling of ejector section should improve overall model reliability.

Cost analysis for both solutions according to suggested solutions for given climate

Further analysis could investigate necessary investment cost and possible reduction of exploitation costs due to improved systems. According to the wide range of the high pressure optimal level, regulation and automation equipment should be concerned as less challenging matter. On the other hand, improvement process of ejectors efficiency and automated control strategy for autonomous fishing vessel should be considered as crucial for further performance improvement of the whole cycle and implementation as an actual marine application.

Appendix A

Nomenclature

Acronyms and abbreviations

GWP Global Warming Potential

ODP Ozone Depletion Potential

R717 Ammonia

HC Hydrocarbons

R744 Carbon-dioxide

TFA Trifluoroacetic acids

HF Hydrogen fluoride

R1234yf Tetrafluoropropene

HFC Hydrofluorocarbons

HFO Hydrofluoroolefins

R134a Tetrafluoroethane

VRC Volumetric Refrigeration Capacity

COP Coefficient of Performance

IHX Internal Heat Exchanger

LPR Low Pressure Receiver

MER Mass Entrainment Ratio

SN Suction Nozzle

MN Motive Nozzle

IPR Intermediate Pressure Receiver

SST Sea Surface Temperature

NEO NASA Earth Observation

EES Engineering Equation Solver

IP Intermediate Pressure

Roman Letters

p pressure, *bar*

h specific enthalpy, *kJ/kg*

s specific entropy, *kJ/kg • K*

\dot{m}_{SUC} mass flow rate, *kg/s*

Greek Letters

χ Mass Entrainment Ratio, -

η Efficiency, %

Subscripts

in Ejector inlet

out Ejector outlet

is Isentropic

mn Motive nozzle

sn Suction nozzle

COMP Compressor

EVAP Evaporator

DIF Diffuser outlet

VALVE Expansion valve

MOT Motive nozzle port

FGAS Flash gas

LPR Lower Pressure Receiver

PAR Parallel compressor

BASE Base compressor

Appendix B

Carbon-dioxide as a working fluid

B.1 Background

Concerning early years of vapour refrigeration systems, natural working fluids were used in vast majority of industrial applications. Having on regard marine refrigeration, CO₂ was more common in a marine applications than ammonia. The reasons were related to the safety requirements, while an ammonia toxicity was often challenging for the safety treatment. Hence, despite lower efficiency, the R744 system were the most common at ships installations. Nowadays technology improvement allows for several adaptations making CO₂ system good competitor in economic areas as well. Moreover, several thermodynamic properties are more beneficial than phasing-out HFCs group. Finally, ecological label related with natural refrigerant becomes more and more demanded all over the world what has its results in the form of a law regulations.

B.2 Thermodynamic characteristic

Vapour pressure

The mentioned cycle adaptation is strictly related with thermodynamic parameters of CO₂. Critical point temperatures are relatively low in comparison to nowadays HFCs refrigerants. On the other hand, the critical pressure is approximately of 73.83 bar ([IPU & Department of Mechanical Engineering of Technical University of Denmark, 2017](#)) what is definitely high having regard low

critical temperature and comparison to other common synthetic refrigerants. Due to this, supercritical states occurs when system is operating at high temperatures of heat rejection. From the point of view of low temperatures, the triple point is located at -56°C with the pressure of 5.18 bar (IPU & Department of Mechanical Engineering of Technical University of Denmark, 2017). Those conditions indicates the lowest possible operation of evaporator, in practice some safety buffer must be ensured due to possibility of solid CO_2 formation (American Society of Heating Refrigerating and Air-Conditioning Engineers, 2014). Consequences of the described pressure levels are related with fluid properties. First of all, high absolute pressure of low pressure side results in significantly low specific volume. This results in smaller sizes of the compressor and heat exchangers. Steep saturation curve in high pressures region ensures small temperature drop corresponding to the pressure drops. As a result, system could be designed for higher efficiency or the compact sizing according to a higher fluid flow velocity. Similarly, favourable conditions of heat transfer are related with a lower viscosity and a surface tension than those of the other refrigerants.

Pressure ratio

According to the $p(\log)$ - h diagram presented in Fig. B.1 (F-Chart Software, 2016), the pressure ratio between high pressure and low pressure side can take values from the range of approximately 1.8 to 4. The maximum values of this range is relatively low when compared to the other refrigerants. Hence, some benefits could be found in the compressor operation. Namely, the pressure ratio is crucial parameter in the isentropic and volumetric efficiency of the compressor. Its lower value corresponds to higher efficiency values. Thus, real R744 cycle would be characterised by the lower energy demand due to more beneficial pressure conditions between high and low pressure side (American Society of Heating Refrigerating and Air-Conditioning Engineers, 2014), (Lorentzen, 1994).

Volumetric refrigeration capacity (VRC)

The relation between available heat of evaporation and the corresponding specific volume at a suction port of a compressor presents volumetric refrigeration capacity (VRC). CO_2 in the

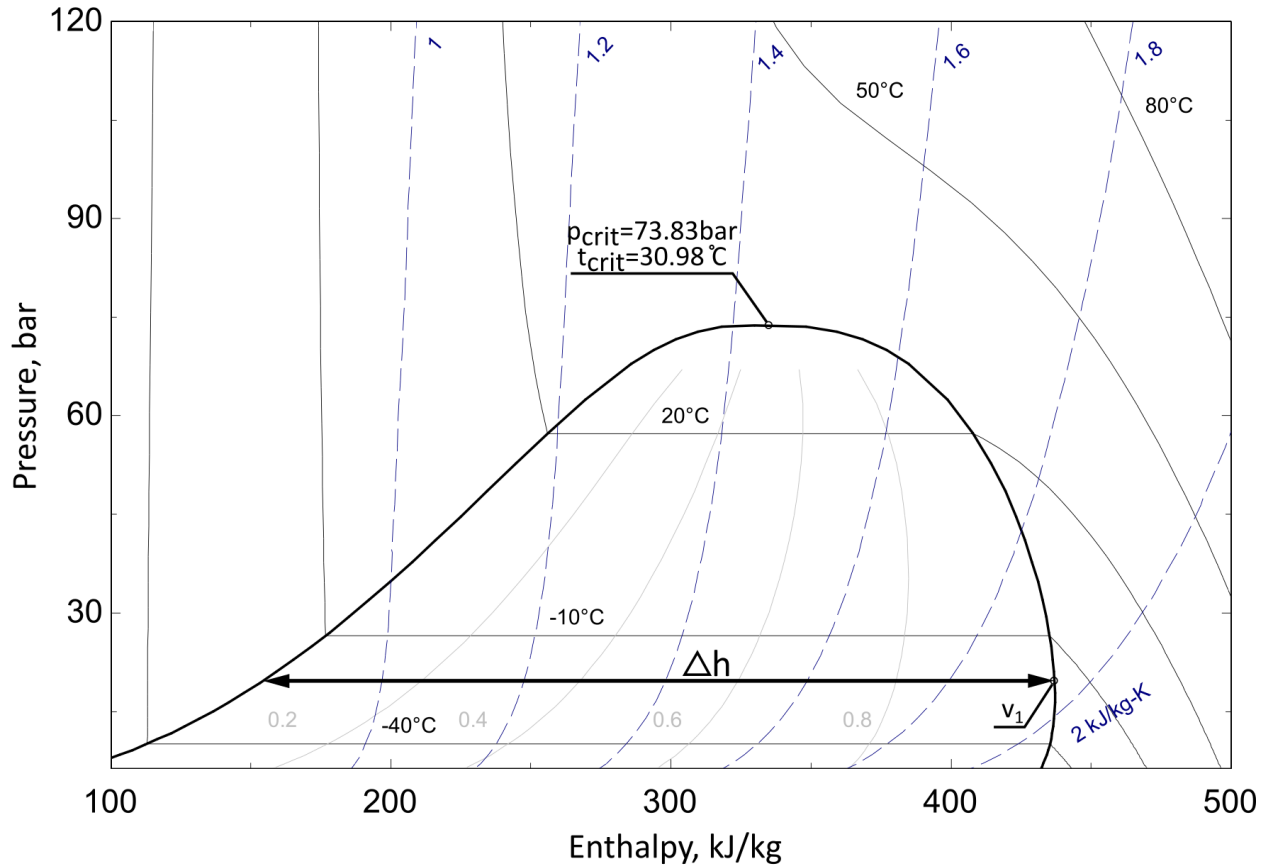

Figure B.1: Pressure (log) specific enthalpy diagram of R744 (F-Chart Software, 2016). Critical point parameters and VRC definition components were marked.

two-phase region ensures high specific enthalpy difference between liquid and vapour saturation line called latent heat of evaporation. Moreover, high saturation pressures provides low specific volumes. Consequently VRC of carbon-dioxide is higher than for any other refrigerant (American Society of Heating Refrigerating and Air-Conditioning Engineers, 2014), (Lorentzen, 1994). Final benefits are located in the significantly smaller compressor size and lower investment costs. The same situation occurs in the case of volumetric heat capacity which is corresponding values of heat pump cycle.

Pressure drop influence on saturation temperature

R744 is characterised by high ratio between the pressure drop and the corresponding drop in the saturation temperature. This trend has consequences in small temperature loss with re-

Table B.1: Temperature-pressure gradient in low temperatures for NH₃ and CO₂ (IPU & Department of Mechanical Engineering of Technical University of Denmark, 2017).

| Temperature, °C | -40 | -30 | -20 | -10 | 0 |
|---|-------|-------|-------|------|------|
| $\Delta T/\Delta p$ (NH ₃), K/bar | 26.04 | 17.20 | 11.85 | 8.46 | 6.23 |
| $\Delta T/\Delta p$ (CO ₂), K/bar | 2.70 | 2.08 | 1.65 | 1.33 | 1.09 |

spect to pressure drops in the piping system. As was shown in Table B.1 (IPU & Department of Mechanical Engineering of Technical University of Denmark, 2017), depending on the saturation temperature, the temperature drop is 6-10 times lower for CO₂ than for ammonia with the same pressure drop. Similar trends are maintained for most HFCs (Hydrofluorocarbons) and Hydrocarbons (HC). This CO₂ feature can be converted into two advantages of refrigeration unit. Firstly, the system can be designed with similar pressure losses when compared to other refrigerant with simultaneously higher efficiency. On the other hand, piping dimensioning can be reduced giving lower investment cost and compact system sizing. Finally, benefits can be joined in compromise giving higher efficiency and relatively smaller sizes of heat exchangers and piping.

Heat transfer conditions

The mentioned temperature losses are in a proportional relation with the heat transfer resistance. In the case of CO₂ low values of $\Delta T/\Delta p$ and low liquid surface tension results in the favourable conditions for nucleate boiling (American Society of Heating Refrigerating and Air-Conditioning Engineers, 2014). The difference between these conditions is relatively high in comparison with NH₃, where superheat required for bubble expansion is almost 20 times higher than for CO₂ (F-Chart Software, 2016). Further, the evaporators are less influenced by the flow velocity. This feature of CO₂ becomes a disadvantage at lower loads where heat transfer is dominated by convection/conduction, in such conditions ammonia offers better heat transfer conditions. However, R744 results in more efficient heat transfer than HFCs regardless of the major mechanism of the process.

B.3 Environmental and economic features

According to the Montreal ([United Nations Environment Programme \(UNEP\), 1987](#)) and Kyoto ([United Nations Framework Convention on Climate Change \(UNFCCC\), 1997](#)) protocols and further by European Commission Regulation ([European Commission, 2014](#)), CO₂ ensures no limitations of use in further refrigeration development. In the case of the Montreal and Kyoto protocols two crucial environmental factors described R744 as one of the most environmental friendly working fluid. Namely, in Global Warming Potential (100 years) factor is based on the CO₂ as reference value of 1, while common HFC-R134a value is equal of 1300 ([American Society of Heating Refrigerating and Air-Conditioning Engineers, 2016](#)). Hence, the GWP factor indicates heat amount captured by certain gas in the atmosphere in the relation to reference substance, i.e. CO₂. Regulations of Norwegian import scenario in the case of such an installation provide the tax where GWP value is strictly multiplier of tax value. Consequently, introducing into operation unit with R134a as working fluid results in high taxes of such an investment. Second of the mentioned crucial factors is Ozone Depletion Potential (ODP) which describes carbon-dioxide as harmless for the ozone layer. The reference value is related with trichlorofluoromethane (CFC-11) and is equal of 1 ([American Society of Heating Refrigerating and Air-Conditioning Engineers, 2016](#)). Working fluids of lower impact to ozone layer are described by lower values where 0 is the lowest possible according to the definition of ODP. Natural working fluids as carbon-dioxide, ammonia as well as hydrocarbons are characterised by the lowest value. Finally, European Commission Regulation ([European Commission, 2014](#)) provided restriction of vast majority of commonly used refrigerants of high environmental impact on the basis of GWP and ODP values. Such a limitations are not related with natural refrigerant as CO₂ now or in the future. This is a result of the environmentally friendly character of this working fluid.

Safety of operation and investment advantages

A document ensured by American Society of Heating Refrigerating and Air-Conditioning Engineers assigned R744 to a group with the most safety of exploitation ([American Society of Heating Refrigerating and Air-Conditioning Engineers, 2016](#)). Carbon-dioxide is non-flammable and

non-toxic substance. These features confirm that R744 is safer in use than R717 (toxic) or HCs (flammable). The ammonia's toxicity is related with additional cost of safety equipment and ventilation. Moreover, restrictions of the machinery room location could be concerned as a drawback. From this reason in some applications ammonia is avoided, i.e. marine industry. Flammability of HCs introducing several safety requirements in the area of fire-fighting measures and especially localisation of installation. Due this several industrial areas are forbidden to utilise HCs because of the manufacturing features of this industry, i.e. metallurgy, high-temperature, sparks. Additional costs reduction related with smaller compressors size and compact sizing of the piping and heat exchangers provides an environmental friendly labelled and cost effective investment of R744 refrigeration system. Some challenges in the investment costs area are related with the HFO working fluids thus most of first applications are focused on Mobile Air Conditioning and small domestic refrigerators (Mota-Babiloni et al., 2017). HFO applications becomes more and more popular however some additional factors of exploitation safety have to be considered. Namely, burning process of these ultra-low GWP synthetic refrigerants from group R1234 results in toxic products such as a trifluoroacetic acids (TFA) or hydrogen fluoride (HF) with real danger to human health in closed spaces such as garages (Hurley et al., 2008). On the other hand, refrigerants from R1234 group are characterised by safety class A2/L, where possibility of a safe service and maintenance were confirmed (Imamura et al., 2015). In the mentioned economic and efficiency area, first analysis were delivered as well. Mota-Babiloni presented study (Mota-Babiloni et al., 2015) on alternative mixtures based on HFO and HFC in order to substitute high GWP refrigerants banned by F-gas regulation (European Commission, 2014). This study presented comparison of economic benefits of each working fluid group. Carbon-dioxide was considered in the comparison showing more efficient solution than mentioned mixtures.

B.4 Classical R744 refrigeration unit

Traditional system proposed by Gustav Lorentzen

Historical background for CO₂ as an alternative for synthetic refrigerants is related with the activity of Prof. Gustav Lorentzen associated with SINTEF and NTNU, Trondheim. Several works were published according to the CO₂ revival in refrigeration industry (Lorentzen, 1994), (Lorentzen, 1995). Moreover, first investigations proved possibility of more energy efficient R744 cycle than traditional HFC. For further development of R744, transcritical operation has to be considered in order to obtain wider scope of applications. However, transcritical operation differs CO₂ system from traditional refrigerant with constant-temperature of heat rejection basing on the condensation process. The major difference is related with the gliding temperatures of heat rejection and high expansion losses in the case of operation near critical point of CO₂. In order to avoid these losses, several solutions were provided bringing R744 energy competitive solution at the refrigerants market.

Major change in comparison with traditional systems

The major difference in comparison with traditional systems is mentioned transcritical operation related with low temperature and high pressure of the critical point of CO₂. Such an operation is related with gliding temperatures of heat rejection. This becomes an advantage if system is designed properly. Namely, temperature losses related with the heat transfer process can be minimised, while minimum temperature difference is ensured. Due to this, similar temperature profiles results in lower losses. A small temperature losses are a result of the proper design of the heat rejection process which is regarding match of the temperature profiles of the coolant fluid and cooled CO₂. Going further, ensured minimum temperature difference is closing the cycle to Carnot cycle. Nevertheless, in order to achieve the mentioned similar profiles, the required temperature rise of the cooling media should be relatively high. Founding a proper application for such high temperature rise ensures high efficient cycle work. One of the most suited applications is heating of the hot tap water where typical temperature gain is approximately 50-60°C. Nevertheless, transcritical operation in many cases becomes disadvantage and if the heat

rejection temperatures become low enough system should be run in the subcritical mode.

Area of possible application

The solution described above is literally based on the heat recovery. This approach can be utilised in sophisticated systems where the cooling and heating demands are simultaneously on relatively high level, i.e. supermarkets or dairy industry. Similar situations occur in the case of hotel heating and cooling system where high demand of hot tap water production is covered with demand of space cooling. Another application based on the compact system sizing and green label can be found in the marine and transport industry. Development of Heating, Ventilation and Air Conditioning (HVAC) systems for railroad and automotive industry has already been proposed by the market leaders (Hafner et al., 2014), (Hafner, 2016), (Polzot et al., 2017), (Minetto et al., 2016). The improvement possibilities of application for hot waters fishing vessels is presented in this study.

Various ambient conditions as the crucial impact factor - high expansion losses in high ambient conditions

Nevertheless, beside of the heat recovery, some effort should be focused on the throttling losses reduction. Significantly higher expansion losses occurs in the case of high temperatures of the heat rejection and supercritical pressure. In Fig. B.2, the range of the expansion loss related to various temperatures at supercritical pressure (90 bar) before expansion device was presented. The expansion process ends at temperature -5°C which can be utilised i.e. for chilling purposes. Amount of the expansion losses for each temperature point is marked by blue area. With the increasing temperature, the area becomes larger. Moreover, expansion process ends in the region of higher specific enthalpies. As a consequence, the expansion losses increases and cooling capacity decreases. Finally this results in deterioration of systems performance. Two direct approaches for avoiding these losses can be introduced. Firstly, the temperature before expansion device should be reduced in order to minimise this loss (Lorentzen, 1994). Nevertheless, in high ambient conditions efficient reduction of this temperature often becomes challenging matter of system design and operation process. Hence, various system approaches were developed ac-

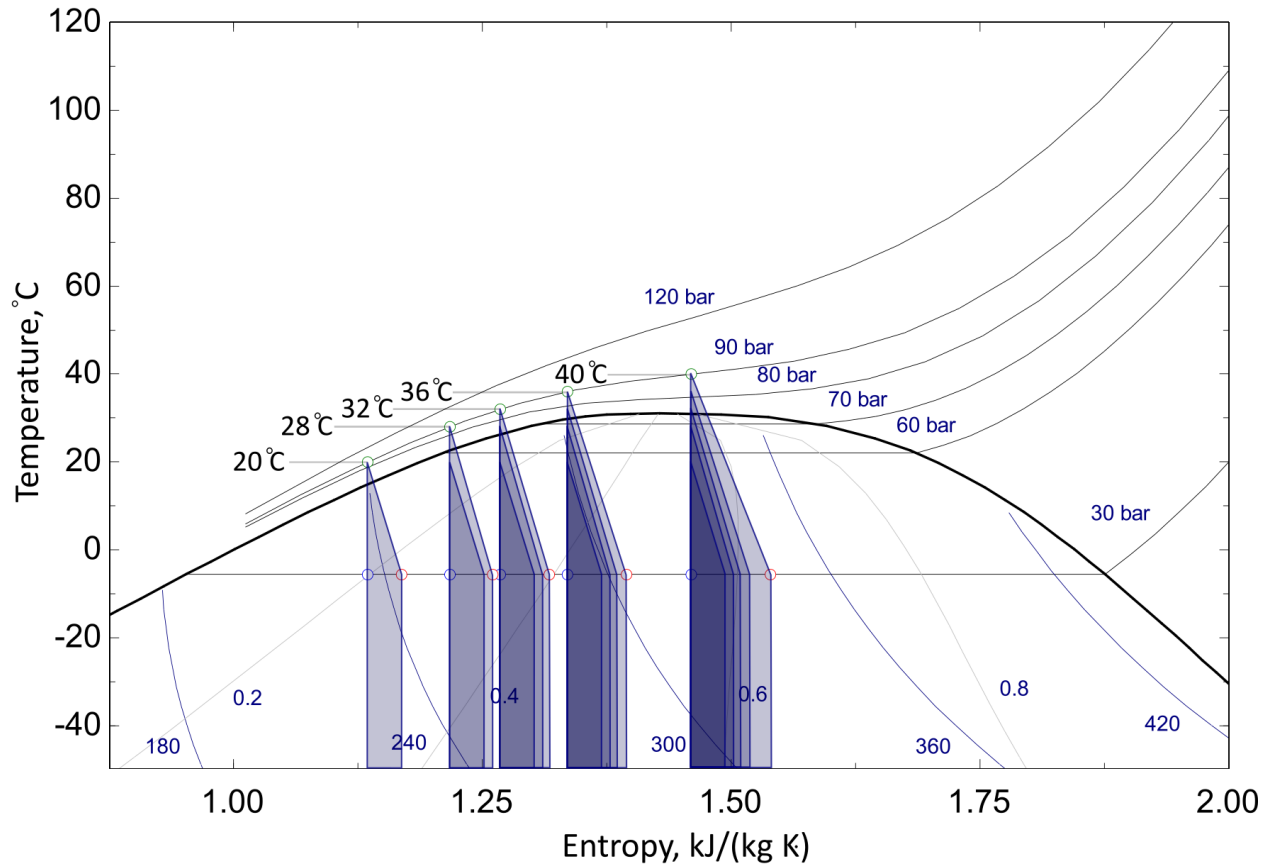

Figure B.2: Temperature specific entropy diagram for R744. The expansion losses for various temperatures and 90 bar of gas cooler pressures were marked. The increasing temperature is related with decreasing cooling capacity and the increasing expansion losses.

According to operation in high ambient conditions (Lorentzen, 1995). Two of the most common solutions were described in the next section. The other solution is based on the pressure regulation. For constant temperature of R744 before the expansion valve, pressure increment results in higher cooling capacity increment than compressor work increment. Simultaneously, COP of cycle is increased. This approach is characterised by the optimum point when the compression work increment becomes higher than the gained cooling capacity.

B.5 Improvement possibilities in the case of hot climates application

Idea of ejector implementation

The previously described expansion losses might be converted into usable work potential in direct or indirect way. The direct solutions are based on obtaining mechanical work as a result of expander implementation (Lorentzen, 1995). Gear or turbine as the expander allows for the direct recovery of expansion losses. The recovered work can be utilised for the compressor work or auxiliary machines, i.e. fans. On the other hand, construction of gear or turbine type expander can be complicated. As a consequence, more reliable devices with no moving parts could be demanded for ensuring constant system operation with no additional services or maintenances. Features of ejectors meet the mentioned requirements. These devices are characterised by a relatively simple construction, no moving parts and reliable operation. Moreover, in the case of refrigeration cycle, besides the expansion work recovery some additional ejector functionalities can be introduced in order to improve system performance (Hafner et al., 2014). Namely, additional liquid refrigerant circulation allows for a reduction of necessary stream flowing through evaporator. The ejector work depends mostly on the available pressure energy potential at the device motive inlet. A flow geometry should be designed having in regard the phase which is planned to be sucked as well as its amount. Finally, the required pressure lift between sucked and outlet stream has to be concerned as well. The factors which describe geometry and performance of the ejectors used in this study were given in Chapter 2.

Analysis of flash gas valve idea

The improvement of the system performance are possible according to several system configurations. However, flash gas valve and parallel compression systems were evaluated as the least space demanding. Moreover, positive results were presented already in the literature (Gullo et al., 2016a), (Gullo et al., 2016b). Due to space restrictions of the onboard fishing vessel these modifications of RSW installation were considered. Idea of flash gas valve was presented in Fig. B.3, where intermediate pressure receiver (IPR) was introduced to classical refrigeration cycle in

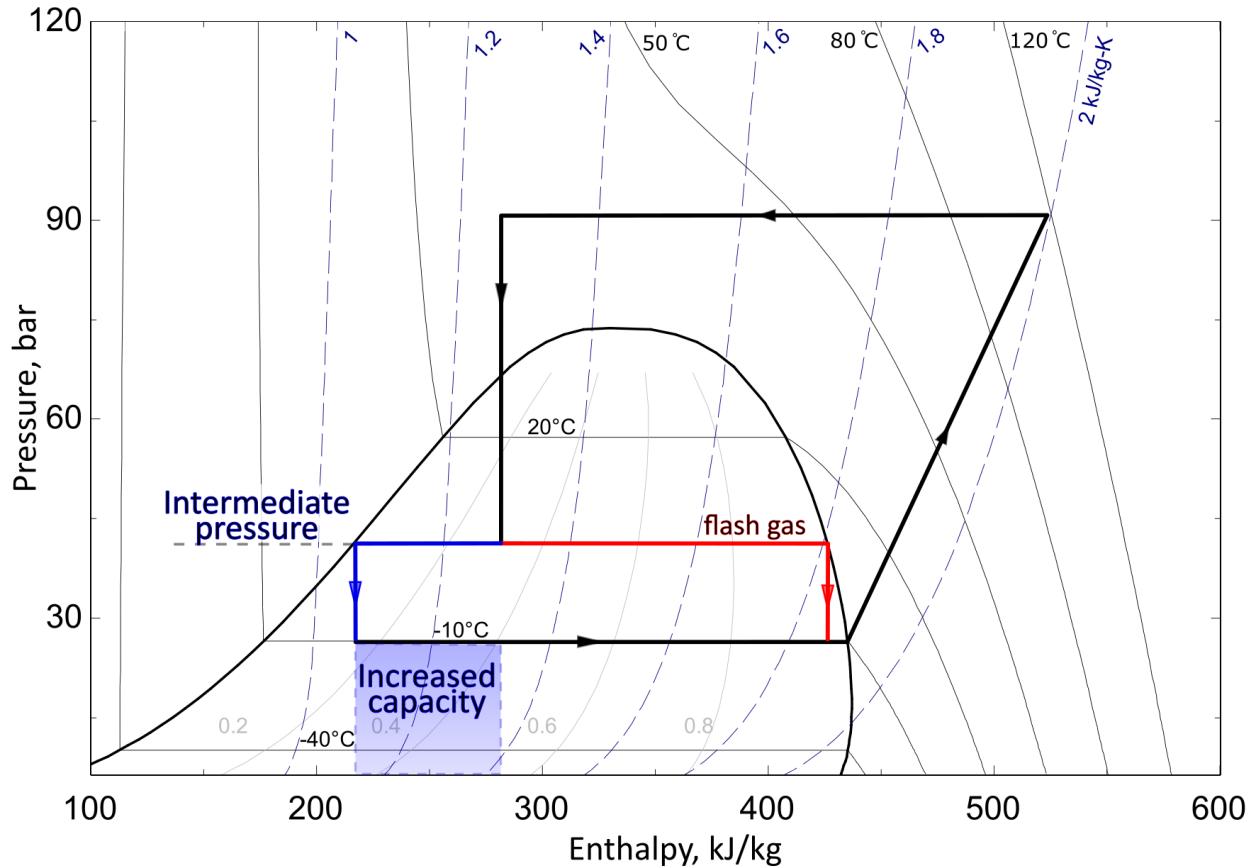

Figure B.3: Pressure(log)-enthalpy diagram for R744 with marked **flash gas system** cycle. The intermediate pressure allows for the liquid-vapour separation and results in the increased cooling capacity.

p(log)-h diagram of R744. IPR is a tank where the pressure is maintained on the level between high- and low pressure side, due to this liquid-vapour phase separation takes place. Next, liquid (blue) and vapour (red) is distributed to separated expansion valves before evaporator and low pressure receiver (LPR) respectively. According to lower value of vapour quality at the evaporator inlet increased capacity (blue area) of cooling cycle is obtained. As a consequence, mass flow rate through evaporator can be reduced. Finally, in optimal conditions on high pressure side and proper pressure in IPR performance improvement is obtained in comparison to traditional cycle. In the light of required modifications only mentioned tank, flash gas expansion valve and piping between IPR, expansion valve and LPR is needed.

Analysis of the parallel compression idea

Fundamentals of the flash gas valve introduction are similar to these which are related with the parallel compression idea. It could be said that the parallel compression is a next step of system improvement on the basis of the flash gas valve solution. The same idea of the IPR introduction is used as it was presented in Fig. B.4. However, after the liquid-vapour separation in the IPR tank, the evaporator is supplied from the liquid line, while gas is directly sucked by the auxiliary compressor. This auxiliary compressor (green line) works in parallel with the base compressor. The solution provides performance improvement on the basis of more favourable compression conditions of the parallel compressor. Namely, flash gas is no more directed to the base compressor which is working between evaporator and gas cooler pressure. The parallel compressor works with the lower pressure ratio than the base compressor what results in the higher isentropic efficiency of the compression process. The amount of compressed auxiliary gas is dependent on the intermediate pressure and conditions after the gas cooler. This solution should ensure higher efficiency than the previously described flash gas valve utilisation. Analysis of slightly more advanced cycles is available literature (Cecchinato et al., 2009). This study reports up to approximately 16% and 28% energy reduction for operating at 4°C and -10°C evaporation temperature. However, additional compressor increases the investment costs. Moreover, ship machinery room should be reconsidered for this variant according to limited space.

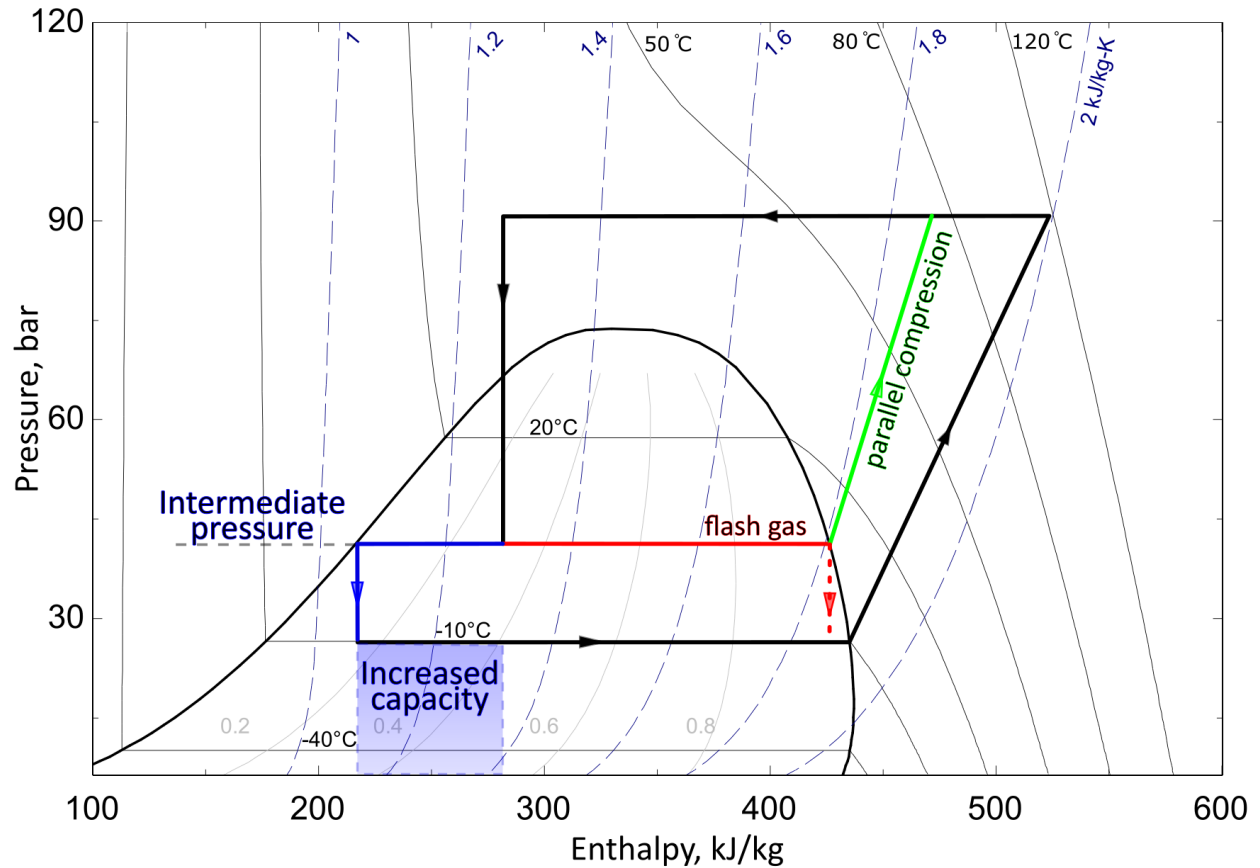

Figure B.4: Pressure(log)-enthalpy diagram for R744 with marked **parallel compression system** cycle. The increased capacity obtained by the liquid separation is a results of IPR introduction. The flash gas is compressed by parallel compression characterised by higher isentropic efficiency due to the lower pressure ratio.

B.6 Fundamentals of mathematical modelling approach implemented to Engineering Equation Solver

Baseline model

System of equations were introduced to Engineering Equation Solver (EES) in order to iteratively solve each model (F-Chart Software, 2016). The program offers Newton-Raphson method as built-in default solving algorithm for obtaining solution of non-linear equations. Criteria of convergence were set to 10^{-5} for both relative residuals and maximum variable change, respectively. Real fluid property library available in the used software was used for determination of thermodynamic parameters.

The developed baseline model was based on the measurement data delivered by the fishing vessel operator. This model was used to evaluate performance of the actual installation. In order to simulate higher operating conditions the modified models were prepared. However, this model was developed on the basis of the Baseline model used for actual cycle evaluation. Namely, the analysis of the Baseline and the modified RSW installations were executed on the basis of energy and mass balance equations. In following formulations, points identification is based on the Baseline System (Fig. 2.1) and the modified system scheme (Fig. 2.3).

Energy delivered to the systems was consumed by the compressors. Hence, total compressors power equation was formulated in B.1:

$$\dot{W} = \dot{m}_{COMP1} \cdot (h_1 - h_{12a}) + \dot{m}_{COMP2} \cdot (h_1 - h_{12b}) \quad (\text{B.1})$$

In order to calculate energy distribution between the evaporator, the ejector difusser and the expansion valve, energy balance of this section was formulated in B.2

$$\dot{m}_{EVAP} \cdot h_8 = \dot{m}_{DIF} \cdot h_7 + \dot{m}_{VALVE} \cdot h_4 \quad (\text{B.2})$$

Mass streams balances B.3 and B.4 was formulated in order to obtain distribution of mass

flow through the evaporator, the expansion valve and the ejector motive nozzle:

$$\dot{m}_{COMP} = \dot{m}_{VALVE} + \dot{m}_{MOT} \quad (B.3)$$

$$\dot{m}_{EVAP} = \dot{m}_{VALVE} + \dot{m}_{DIF} \quad (B.4)$$

where \dot{W} is power, \dot{m} is mass flow rate, h is specific enthalpy. Subscript COMP denotes the compressor, EVAP is the evaporator, DIF is the ejector outlet port, VALVE is the expansion valve, MOT is the ejector motive port. Besides the compressor power consumption, evaluation of the compressor work was based on the equation of compressors isentropic efficiency (B.5).

$$\eta_{is} = (h_{1,s} - h_{12}) / (h_1 - h_{12}) \quad (B.5)$$

where subscript *is* is isentropic and *s* is specific entropy. As a result of simulation, the process mass flow rates of the system were calculated. Hence, calculation of the system power demand at given operating conditions and evaporator load was possible. Further, the system performance was presented in the form of the COP factor defined as follows in equation B.6:

$$COP = \frac{Q_{EVAP}}{\dot{W}} \quad (B.6)$$

where Q_{EVAP} is heat transferred in the evaporator. Equation of evaporator energy balance (B.7) is formulated as following:

$$Q_{EVAP} = \dot{m}_{EVAP} \cdot (h_9 - h_8) \quad (B.7)$$

Modified systems model - flash gas valve and parallel compression

The analysis of the flash gas valve and the parallel compression systems were based on the modified baseline model. In the case of flash gas valve, introduction of IPR, two expansion valves and additional flash gas line was necessary. In order to model this modification, the additional energy balance related with IPR were formulated in equation B.8:

$$\dot{m}_{VALVE} \cdot h_3 + \dot{m}_{DIF} \cdot h_7 = (\dot{m}_{EVAP} + \dot{m}_{FGAS}) \cdot h_{IPR} \quad (B.8)$$

where subscript FGAS is for the flash gas and IPR is for the intermediate pressure receiver. The vapour quality value in the IPR was estimated on the basis of obtained IPR enthalpy and the assumed pressure in the tank. Moreover, mixing of flash gas stream and saturated vapour from LPR was modelled on the basis of mass (B.9) and energy balance (B.10):

$$\dot{m}_{FGAS} \cdot h_{15} + \dot{m}_{LPR} \cdot h_{10} = \dot{m}_{COMP} \cdot h_{16} \quad (\text{B.9})$$

$$\dot{m}_{FGAS} + \dot{m}_{LPR} = \dot{m}_{COMP} \quad (\text{B.10})$$

The parallel compression was related with additional equation of the compressor work (B.11). Mixing of the base compressor stream and auxiliary compressor stream was modelled by mass (B.12) and energy (B.13) balances:

$$\dot{W}_{PAR} = \dot{m}_{COMP,PAR} \cdot (h_{17} - h_{13}) \quad (\text{B.11})$$

$$\dot{m}_{COMP,PAR} + \dot{m}_{COMP,BASE} = \dot{m}_{COMP} \quad (\text{B.12})$$

$$\dot{m}_{COMP,PAR} \cdot h_{17} + \dot{m}_{COMP,BASE} \cdot h_1 = \dot{m}_{COMP} \cdot h_{18} \quad (\text{B.13})$$

where subscript $COMP_{PAR}$ is for the parallel compressor and $COMP_{BASE}$ is the base compressor. Moreover, the separated isentropic efficiency equation (B.14) for parallel compression was added:

$$\eta_{is,PAR} = (h_{17,s} - h_{13}) / (h_{17} - h_{13}) \quad (\text{B.14})$$

where $\eta_{is,PAR}$ is isentropic efficiency of the parallel compressor. Similarly as in the baseline simulations, the system COP was used as evaluation factor. However, in the case of the parallel compression, the work of auxiliary compressor was included in the COP factor defined in the equation B.15:

$$COP = \frac{Q_{EVAP}}{\dot{W} + \dot{W}_{PAR}} \quad (\text{B.15})$$

Additional assumptions

In order to simulate introduced devices in modified models some assumptions and auxiliary calculations had to be carried out. An isentropic efficiency of the base compressors and the parallel compressor was calculated for each simulation on the basis of the high pressure and the evaporation pressure. The efficiency function involved two mentioned arguments and was obtained on the basis of the data of semi-hermetic transcritical CO₂ compressors delivered by the compressor manufacturer (GEA, 2017). Simultaneously, none heat loss from compressors was assumed for both stages. On the basis of the compressor manufacturer data, a superheat of gas at the base compressor suction port was assumed as 10 K (GEA, 2017). Efficiency of IHX was assumed to be 100%.

Ejector operation was modelled on the basis of 1-D homogeneous equilibrium model where each section efficiency and pressure in the mixing section are assumed. Efficiencies of the motive nozzle, suction nozzle and diffuser were assumed to be equal to 85%, 80% and 80% for both vapour end liquid ejectors, respectively. Pressure in the mixer section was lower by 100 kPa than suction nozzle outlet. Liquid ejector in the Baseline System was described by constant efficiency of 1.15% what was related with overcoming only of pressure losses. Further, liquid ejectors in the case of modified systems, were described by constant overall efficiency equal to 15%. According to the large amount of potential recovery work in the case of east-Asian conditions, it was assumed that the ejector work would be enough to suck whole evaporator stream. Another approach was provided in the case of Mediterranean climate where potential recovered work was lower. In this case, ejector efficiency was assumed as a function in the range from 20% to 35% on the basis of performance maps presented in the work of Banasiak (Banasiak et al., 2015). In this study, the ejector efficiency definition (equation B.16) presented by Elbel and Hrnjak (Elbel and Hrnjak, 2008) was used. Namely, the numerator is defined as a difference of enthalpies obtained from an isentropic and isenthalpic compression process from the suction nozzle pressure to the ejector outlet pressure. Second part, the nominator is defined similarly but considers expansion process in the motive nozzle:

$$\eta_{EJ} = \chi \cdot \frac{h|_{s=SN,in} - h_{SN,in}}{h_{MN,in} - h|_{s=MN,in, p=p_{out}}} \quad (\text{B.16})$$

where h is the specific enthalpy, subscript s is the specific entropy in the suction nozzle (SN) and the motive nozzle (MN), p is the pressure, and *in* and *out* are the ejector inlets and outlet, respectively. In this definition, parameter χ called mass entrainment ratio (MER) is defined according to equation B.17.

$$\chi = \frac{\dot{m}_{SN}}{\dot{m}_{MN}} \quad (\text{B.17})$$

where \dot{m} is the mass flow rate.

A representative evaporator load was estimated on the level of 250 kW and this value was assumed for all simulations of high temperatures of heat rejection. Additionally, for the case of most perspective solution in East-Asian climate range of evaporator load was simulated. This range was assumed from 250 kW to 455 kW. Vapour quality at the evaporator outlet was assumed as 0.95. The evaporator pressure was iteratively calculated on the basis of a temperature difference between refrigerant and cooled water. According to cooled water temperature equal to -1°C , the required temperature of refrigerant was calculated as a function of the vapour quality at the evaporator inlet. On the basis of heat transfer coefficient correlation presented in the work of Cheng (Cheng et al., 2006), proper function was approximated in the range of 0.0 and 0.6 of the vapour quality. Finally, according to the constant evaporator load necessary temperature difference were calculated.

In every simulation of high ambient conditions, temperature difference between refrigerant and sea water at gas cooler outlet was assumed as equal to 5 K, as in Baseline installation. Hence, 26°C and 38°C refrigerant temperature at the outlet of gas cooler was tested for Mediterranean and East-Asian climate, respectively.

Bibliography

American Society of Heating Refrigerating and Air-Conditioning Engineers (2014). *Refrigeration Handbook*. ASHRAE, Atlanta, GA, USA.

American Society of Heating Refrigerating and Air-Conditioning Engineers (2016). *ANSI/ASHRAE Standard 34, Designation and Safety Classification of Refrigerants*. ASHRAE, Atlanta, GA, USA.

Andrei Tronin (2017). The satellite-measured sea surface temperature change in the Gulf of Finland. *International Journal of Remote Sensing*, 38(6):1541–1550.

Banasiak, K., Hafner, A., Kriezi, E. E., Madsen, K. B., Birkelund, M., Fredslund, K., and Olsson, R. (2015). Development and performance mapping of a multi-ejector expansion work recovery pack for R744 vapour compression units. *International Journal of Refrigeration*, 57:265–276.

Boccardi, G., Botticella, F., Lillo, G., Mastrullo, R., Mauro, A. W., and Trinchieri, R. (2017). Experimental investigation on the performance of a transcritical CO₂ heat pump with multi-ejector expansion system. *International Journal of Refrigeration*, In Press: doi.org/10.1016/j.ijrefrig.2017.06.013.

Bodys, J., Palacz, M., Haida, M., Smolka, J., Nowak, A. J., Banasiak, K., and Hafner, A. (2017). Full-scale multi-ejector module for a carbon dioxide supermarket refrigeration system: Numerical study of performance evaluation. *Energy Conversion and Management*, 138:312–326.

Carvalho, B. Y. K. D., Melo, C., and Pereira, R. H. (2016). A Study on the Use of Liquid Separators in Variable-Speed Small-Scale Carbon Dioxide Refrigerating Systems. In *12th IIR Gustav Lorentzen Natural Working Fluids Conference*, Paper ID: 1014, Edinburgh, UK.

- Cecchinato, L., Chiarello, M., Corradi, M., Fornasieri, E., Minetto, S., Stringari, P., and Zilio, C. (2009). Thermodynamic analysis of different two-stage transcritical carbon dioxide cycles. *International Journal of Refrigeration*, 32(5):1058–1067.
- Cheng, L., Ribatski, G., Wojtan, L., and Thome, J. R. (2006). New flow boiling heat transfer model and flow pattern map for carbon dioxide evaporating inside horizontal tubes. *International Journal of Heat and Mass Transfer*, 49(21-22):4082–4094.
- Elbel, S. and Hrnjak, P. (2008). Experimental validation of a prototype ejector designed to reduce throttling losses encountered in transcritical R744 system operation. *International Journal of Refrigeration*, 31(3):411–422.
- Elbel, S. and Lawrence, N. (2016). Review of recent developments in advanced ejector technology. *International Journal of Refrigeration*, 62:1–18.
- European Commission (2014). Regulation (EU) No 517/2014 of the European Parliament and of the Council of 16 April 2014 on fluorinated greenhouse gases and repealing Regulation (EC) No 842/2006 Text with EEA relevance. *Official Journal of the European Union*, 57:195–230.
- F-Chart Software (2016). Engineering Equations Solver (EES).
- GEA (2017). VAP for Stationary Applications - version 11.4.2 (online).
- Gullo, P., Cortella, G., Minetto, S., and Polzot, A. (2016a). Overfed Evaporators and Parallel Compression in Commercial R744 Booster Refrigeration Systems – an Assessment of Energy Benefits. In *12th IIR Gustav Lorentzen Natural Working Fluids Conference*, Paper ID: 1039, Edinburgh, UK.
- Gullo, P., Elmegaard, B., and Cortella, G. (2016b). Energy and environmental performance assessment of R744 booster supermarket refrigeration systems operating in warm climates. *International Journal of Refrigeration*, 64:61–79.
- Hafner, A. (2016). R744 train HVAC unit. In *12th IIR Gustav Lorentzen Conference*, Paper ID: 1132, Edinburgh, UK.

- Hafner, A., Försterling, S., and Banasiak, K. (2014). Multi-ejector concept for R-744 supermarket refrigeration. *International Journal of Refrigeration*, 43:1–13.
- Haida, M., Banasiak, K., Smolka, J., Hafner, A., and Eikevik, T. M. (2016). Experimental analysis of the R744 vapour compression rack equipped with the multi-ejector expansion work recovery module. *International Journal of Refrigeration*, 64(August):93–107.
- Hurley, M. D., Wallington, T. J., Javadi, M. S., and Nielsen, O. J. (2008). Atmospheric chemistry of CF₃CF=CH₂: Products and mechanisms of Cl atom and OH radical initiated oxidation. *Chemical Physics Letters*, 450(4-6):263–267.
- Ignacio, J., Villarino, A., and Ángel, F. (2017). Experimental and modelling analysis of an office building HVAC system based in a ground-coupled heat pump and radiant floor. *Applied Energy*, 190:1020–1028.
- Imamura, T., Kamiya, K., and Sugawa, O. (2015). Ignition hazard evaluation on A2L refrigerants in situations of service and maintenance. *Journal of Loss Prevention in the Process Industries*, 36:553–561.
- IPU & Department of Mechanical Engineering of Technical University of Denmark (2017). Cool-Pack; ISO 817:2014; EN 378-1:2008.
- Jin, Z., Eikevik, T. M., Neksa, P., Hafner, A., and Wang, R. (2017). Annual energy performance of R744 and R410A heat pumping systems. *Applied Thermal Engineering*, 117:568–576.
- Joneydi Shariatzadeh, O., Abolhassani, S. S., Rahmani, M., and Ziaee Nejad, M. (2016). Comparison of transcritical CO₂ refrigeration cycle with expander and throttling valve including/excluding internal heat exchanger: Exergy and energy points of view. *Applied Thermal Engineering*, 93:779–787.
- Lorentzen, G. (1994). Revival of carbon dioxide as a refrigerant. *International Journal of Refrigeration*, 17(5):292–301.
- Lorentzen, G. (1995). The use of natural refrigerants: a complete solution to the CFC/HCFC predicament. *International Journal of Refrigeration*, 18(3):190–197.

- Lucas, C. and Koehler, J. (2012). Experimental investigation of the COP improvement of a refrigeration cycle by use of an ejector. *International Journal of Refrigeration*, 35(6):1595–1603.
- Minetto, S., Cecchinato, L., Brignoli, R., Marinetti, S., and Rossetti, A. (2016). Water-side reversible CO₂ heat pump for residential application. *International Journal of Refrigeration*, 63:237–250.
- Mota-Babiloni, A., Makhnatch, P., and Khodabandeh, R. (2017). Recent investigations in HFCs substitution with lower GWP synthetic alternatives: focus on energetic performance and environmental impact. *International Journal of Refrigeration*, In Press: doi.org/10.1016/j.ijrefrig.2017.06.026.
- Mota-Babiloni, A., Navarro-Esbri, J., Barragan-Cervera, A., Moles, F., and Peris, B. (2015). Analysis based on EU Regulation No 517 / 2014 of new HFC / HFO mixtures as alternatives of high GWP refrigerants in refrigeration and HVAC systems. *International Journal of Refrigeration*, 52:21–31.
- NASA Earth Observation (NEO) (2017). Sea Surface Temperature (MODIS).
- Polzot, A., D'Agaro, P., and Cortella, G. (2017). Energy Analysis of a Transcritical CO₂ Supermarket Refrigeration System with Heat Recovery. *Energy Procedia*, 111(September 2016):648–657.
- Ruan, Y., Liu, Q., Li, Z., and Wu, J. (2016). Optimization and analysis of Building Combined Cooling, Heating and Power (BCHP) plants with chilled ice thermal storage system. *Applied Energy*, 179:738–754.
- Sakalli, A. (2017). Sea surface temperature change in the mediterranean sea under climate change: A linear model for simulation of the sea surface temperature up to 2100. *Applied Ecology and Environmental Research*, 15(1):707–716.
- Sarkar, J. and Agrawal, N. (2010). Performance optimization of transcritical CO₂ cycle with parallel compression economization. *International Journal of Thermal Sciences*, 49(5):838–843.

Tsamis, K., Ge, Y., Santosa, I., Tassou, S., Bianchi, G., and Mylona, Z. (2017). Energy analysis of alternative CO₂ refrigeration system configurations for retail food applications in moderate and warm climates. *Energy Conversion and Management*, In Press: [dx.doi.org/10.1016/j.enconman.2017.08.001](https://doi.org/10.1016/j.enconman.2017.08.001).

United Nations Environment Programme (UNEP) (1987). Montreal Protocol.

United Nations Framework Convention on Climate Change (UNFCCC) (1997). Kyoto Protocol.

Jakub Bodys

MECHANICAL ENGINEER · POWER ENGINEERING

3 Maja 73A, 44-230, Czerwionka-Leszczyny, Silesia, Poland

☎ (+48) 883-280-733 | ✉ jakub.bodys@gmail.com | 🌐 jakub.bodys

Education

Institute of Thermal Technology of Silesian University of Technology

Gliwice, Poland

MSc. IN POWER ENGINEERING

Feb. 2016 - Sep. 2017

- Thesis title: Design and experimental investigation of CO₂ ejector pumps for RSW systems
- Thesis realised during 5 months stay at Department of Energy and Process Engineering, NTNU, Trondheim, Norway
- Thesis realised for industrial partner Kuldeteknisk AS under supervision of Prof. Armin Hafner (NTNU), Dr Krzysztof Banasiak (SINTEF Energy Research) and Prof. Jacek Smolka (SUT)

Institute of Thermal Technology of Silesian University of Technology

Gliwice, Poland

BSc. IN MECHANICAL ENGINEERING

Sep. 2012 - Feb. 2016

- Thesis title: Numerical investigation on the two-phase ejector efficiency installed in CO₂ refrigeration systems
- Thesis realised as a part of international research project under supervision of Prof. Jacek Smolka

Experience

Engineering Services MESCO

Tarnowskie Gory, Poland

INTERN-SHIP

Jul. - Sept. 2015

- Simulations of heat transfer and air flow in machinery hall of thermoforming factory
- Simulations of heat transfer with heat generation in tires of heavy vehicles
- Simulations of water cooling in electronic devices
- Simulations of air flow through suction ducts of coal boiler in large power plant and influence analysis of implemented silencers

Engineering Services MESCO

Tarnowskie Gory, Poland

INTERN-SHIP

Jun. - Aug. 2014

- Generation of numerical domains for structure analysis purposes
- Development of automatized numerical tool for analysis of blood flow with aneurysm surroundings located in the brain arteries

Projects

Heterogeneous two-phase transcritical model of CO₂ flow in ejectors for state-of-the-art refrigeration units

Institute of Thermal Technology

(Gliwice, Poland)

MAIN CONTRACTOR

2017 - 2021

- Development of heterogeneous model of transcritical CO₂ flow in converging-diverging motive nozzle
- Development of mixture model of two-phase flow in transcritical CO₂ ejector
- Development of LES turbulence modelling approach in transcritical CO₂ ejector
- Development of computational tool for CO₂ ejector design process for state-of-the-art refrigeration units

Development of numerical model and variant analysis of wind influence on large power plant

Office of Measurement Services

ENERGOPOMIAR (Gliwice, Poland)

MAIN CONTRACTOR

2016 - 2017

- Development of numerical models on the basis of power plant documentation
- Performing simulations of power plant surrounding and analysis of forces at the buildings walls in case of various wind configurations
- Analysis of the simulations results

Application of an innovative expansion work recovery system with multiple ejectors for energy performance improvement in the R744 refrigeration installations for supermarkets

Institute of Thermal Technology

(Gliwice, Poland) and

SINTEF Energy (Trondheim, Norway)

CONTRACTOR

2016 - 2016

- Generation of numerical domains on the basis of ejectors documentation
- Performing simulations of R744 ejectors work in various operating conditions
- Analysis of the simulations results and preparation of scientific publications

Identification and optimisation of power cycle components with use of CFD analysis

CONTRACTOR

- Generation of numerical models of furnace on the basis of documentation
- Performing simulations of gas fuel combustion in the furnace
- Realised as a part of Project Competitive Mechanical Engineers for Energy Sector

*Institute of Thermal Technology
(Gliwice, Poland)*

2013 - 2014

Publications

Full-scale multi-ejector module for a carbon dioxide supermarket refrigeration system: Numerical study of performance evaluation

J. BODYS, M. PALACZ, M. HAIDA, J. SMOLKA, A.J. NOWAK, K. BANASIAK, A. HAFNER

Energy Conversion and Management, 138 (2017) 312-326

IF(2015)=4.801

Performance of fixed geometry ejectors with a swirl motion installed in a multi-ejector module of a CO2 refrigeration system

J. BODYS, J. SMOLKA, M. PALACZ, M. HAIDA, K. BANASIAK, A.J. NOWAK, A. HAFNER

Energy, 117 (2016) 620-631

IF(2015)=4.292

Influence of external flue gas recirculation on gas combustion in a coke oven heating system

S. GAMRAT, J. PORAJ, J. BODYS, J. SMOLKA, W. ADAMCZYK

Fuel Processing Technology, 152 (2016) 430-437

IF(2015)=3.847

Performance comparison of fixed- and controllable-geometry ejectors in a CO2 refrigeration system

J. SMOLKA, M. PALACZ, J. BODYS, A. FIC, Z. BULINSKI, A.J. NOWAK, K. BANASIAK, A. HAFNER

International Journal of Refrigeration, 65 (2016) 172-182

IF(2015)=2.291

Influence of staging air on gas combustion in a coke oven heating system

J. PORAJ, S. GAMRAT, J. BODYS, J. SMOLKA, W. ADAMCZYK

Clean Technologies and Environmental Policy, 18 (2016) 1815-1825

IF(2015)=1.934

Numerical investigation of an r744 liquid ejector for supermarket refrigeration systems

M. HAIDA, J. SMOLKA, M. PALACZ, J. BODYS, A.J. NOWAK, Z. BULINSKI, A. FIC, K. BANASIAK, A. HAFNER

Thermal Science, 20 (2016) 1259-1269

IF(2015)=0.939

Conferences

The 12th IIR Gustav Lorentzen Natural Working Fluids Conference

J. BODYS, J. SMOLKA, M. PALACZ, M. HAIDA, K. BANASIAK, A.J. NOWAK, A. HAFNER

Edinburgh, UK

Aug. 2016

- 3-D CFD modelling of multi-ejector module performance.

The 7th European Thermal-Sciences Conference EURO THERM

J. BODYS, J. SMOLKA, M. PALACZ, M. HAIDA, K. BANASIAK, A.J. NOWAK, A. HAFNER

Cracow, Poland

Jun. 2016

- Parallel work of CO2 ejectors installed in a Multi-Ejector module of refrigeration system

The 22nd International Symposium on Combustion Processes

J. BODYS, S. GAMRAT, J. PORAJ, J. SMOLKA

Jura, Poland

Sep. 2015

- CFD-based identification of temperature field irregularity in a refining furnace

The 28th International Conference on Efficiency, Cost, Optimization, Simulation and Environmental Impact of Energy Systems ECOS

J. BODYS, J. SMOLKA, M. PALACZ, A.J. NOWAK, Z. BULINSKI, A. FIC, K. BANASIAK, A. HAFNER

Pau, France

Jul. 2015

- Efficiency of the fixed and controllable ejectors installed in a CO2 refrigeration system

Awards

- 2016 **Stipendist**, Scholarship of Minister of Science and Higher Education for scientific achievements *Warsaw, Poland*
- 2014-17 **Stipendist**, Scholarship of Rector of Silesian University of Technology for scientific achievements *Gliwice, Poland*
- 2015 **Winner**, Competition for the best student scientific publication of Faculty of Energy and Environmental Engineering (Silesian University of Technology) *Gliwice, Poland*

Courses

Solving Methods for Inverse Problems

INSTITUTE OF THERMAL TECHNOLOGY

Gliwice, Poland

Sep. 2016

Thermovision measurements and recording and analysis of high speed phenomena

EC TRAINING CENTER

Cracow, Poland

Nov. 2015

Introduction to fluid flow analysis - Ansys Fluent

ENGINEERING SERVICES MESCO

Tarnowskie Gory, Poland

Oct. 2015

Technician of mobile air conditioning systems

OFFICE OF TECHNICAL EXPERTISES AND TRAINING CENTER BETIS

Radom, Poland

Jun. 2015

State-of-art computer techniques for machinery and power engineering design

ENGINEERING SERVICES MESCO, INSTITUTE OF THERMAL TECHNOLOGY

Wisla, Poland

Sep. 2013

Software

ENGINEERING TOOLS

Ansys Fluent / IcemCFD / CFX / AIM, advanced

Engineering Equation Solver, advanced

Octave, basic

Aspen Plus, basic

Epsilon, basic

COMPUTER AIDED DESIGN

Ansys SpaceClaim / DesignModeller, advanced

AutoCAD, advanced

SolidWorks, intermediate

Catia, basic

DATA PRESENTATION

Microsoft Office Word / PowerPoint / Excel, advanced

InkScape, advanced

LaTeX, intermediate

Languages

Polish, native language

English, C1

German, A1