



Norwegian University of
Science and Technology

Investigation of tension in anchor lines and influence on vessel behaviour

Time domain simulation of Barge response

Petter Svardal Langeland

Master of Science in Ship Design

Submission date: June 2016

Supervisor: Karl Henning Halse

Norwegian University of Science and Technology Ålesund
Faculty of Maritime Technology and Operation

Mandatory statement

Each student is responsible for complying with rules and regulations that relate to examinations and to academic work in general. The purpose of the mandatory statement is to make students aware of their responsibility and the consequences of cheating. **Failure to complete the statement does not excuse students from their responsibility.**

Please complete the mandatory statement by placing a mark <u>in each box</u> for statements 1-6 below.		
1.	I/we hereby declare that my/our paper/assignment is my/our own work, and that I/we have not used other sources or received other help than is mentioned in the paper/assignment.	<input type="checkbox"/>
2.	I/we hereby declare that this paper <ol style="list-style-type: none"> 1. Has not been used in any other exam at another department/university/university college 2. Is not referring to the work of others without acknowledgement 3. Is not referring to my/our previous work without acknowledgement 4. Has acknowledged all sources of literature in the text and in the list of references 5. Is not a copy, duplicate or transcript of other work 	Mark each box: 1. <input type="checkbox"/> 2. <input type="checkbox"/> 3. <input type="checkbox"/> 4. <input type="checkbox"/> 5. <input type="checkbox"/>
3.	I am/we are aware that any breach of the above will be considered as cheating, and may result in annulment of the examination and exclusion from all universities and university colleges in Norway for up to one year, according to the Act relating to Norwegian Universities and University Colleges, section 4-7 and 4-8 and Examination regulations .	<input type="checkbox"/>
4.	I am/we are aware that all papers/assignments may be checked for plagiarism by a software assisted plagiarism check	<input type="checkbox"/>
5.	I am/we are aware that NTNU will handle all cases of suspected cheating according to prevailing guidelines.	<input type="checkbox"/>
6.	I/we are aware of the NTNU's rules and regulation for using sources.	<input type="checkbox"/>

Publication agreement

ECTS credits: 30

Supervisor: Karl Henning Halse

Agreement on electronic publication of master thesis

Author(s) have copyright to the thesis, including the exclusive right to publish the document (The Copyright Act §2).

All theses fulfilling the requirements will be registered and published in Brage, with the approval of the author(s).

Theses with a confidentiality agreement will not be published.

I/we hereby give NTNU the right to, free of charge, make the thesis available for electronic publication: yes no

Is there an [agreement of confidentiality](#)? yes no

(A supplementary confidentiality agreement must be filled in and included in this document)

- If yes: Can the thesis be online published when the period of confidentiality is expired? yes no

This master's thesis has been completed and approved as part of a master's degree programme at NTNU Ålesund. The thesis is the student's own independent work according to section 6 of Regulations concerning requirements for master's degrees of December 1st, 2005.

Date: 03.06.16

**MASTER THESIS 2016
FOR
STUD.TECHN. PETTER LANGELAND**

Time domain simulation of tensile forces in anchor lines and influence on vessel behaviour

In the aftermath of the accident with “M/S Bourbon Dolphin” in 2007, the Norwegian Maritime Directory(NMD) have come up with suggestions on how to improve the safety under anchor handling and towing operations. Some clear directions are given but the guidelines put emphasis on performing the necessary calculations in advance of the operations in able to predict the forces and moments acting on the vessel. This is challenging as the complexity of the operations is varying and so are the forces.

The thesis shall investigate how forces in the mooring line is affecting the vessel response, mainly considering heave, roll and pitch motions. The research method will have a quantitative approach as time domain analysis will be used as research tool. The simulations will be done in the FEA simulation software AquaSim provided by Aquastructures AS.

The objectives of this thesis are:

- Implement a vessel and mooring line model in AquaSim
- Set up study cases and investigate the effects that the mooring line has on the vessel response by using time domain analysis
- Verify the suitability of AquaSim in this type of analysis

Supervision at Aalesund UC.: Karl Henning Halse

Finish: 3. June 2016 Signature candidate:



(Petter Langeland)

Abstract

The topic of this thesis is time domain analysis of mooring line effects on a vessels response, where a barge is used as test model. This type of simulation can be used to investigate and evaluate how the forces from the mooring line affects the vessels response over time. As an introduction, some background theory regarding anchor handling and vessel stability is presented. The objective of the thesis is to show how the mooring line is affecting the vessel response, mainly heave, pitch and roll.

Both the barge and mooring line is modelled and simulated by using Aquasim, a software package delivered by Aquastructures. The package includes the programs AquaEdit, AquaBase, AquaView and AquaTool which are all used as aid in this project. This software is specialized on mooring analysis related to the aquaculture industry and some offshore operations. For purely analysing vessel response it is unproven and verifying its suitability is a part of the project.

The barge model is matched against ShipX, which is a proven software when it comes to vessel response simulation, to verify that the model is acting realistically. Due to limitations to the program the model used for this project has some limitations which are reflected upon at the end of the report.

Different case studies are simulated. The results indicate that there is a connection between the variations in mooring line force and the vessel response. Worsened environment, mainly increased wave height and current causes more variations and unpredictability.

Preface

This master thesis is written at the Faculty of Maritime Technology and Operations at NTNU Ålesund. It represents the end of my days as a student NTNU Ålesund, former AAUC. The years I have spent in Ålesund and abroad have been rewarding, both academically and socially as I have learned a lot and made good friends from all over the world.

I would like to thank my supervisor Karl Henning Halse for providing me with this project and for his good support and advices throughout my work on my thesis. He showed great flexibility as he always provided other options when things did not go as planned.

Petter Svardal Langeland

Ålesund, June 2016

Table of contents

List of figures	xiii
List of tables	xiv
Abbreviations	xv
1 INTRODUCTION.....	1
1.1 Background	1
1.2 Anchor Handling	2
1.2.1 Anchor Handling Tug Supply vessel (AHTS/AHV).....	2
1.2.2 Equipment	3
1.2.3 Anchor handling operation.....	3
2 BACKGROUND THEORY	5
2.1 Definition of motions	5
2.2 Stability	6
2.2.1 Righting moment.....	7
2.2.2 GZ-curve	8
2.2.3 Metacentre	8
2.2.4 Longitudinal stability	9
2.3 Vessel response	10
2.3.1 Response in regular waves	10
2.3.2 Strip Theory.....	11
2.4 Stability criteria	11
2.4.1 General stability criteria	12
2.4.2 Special criteria for AHTS.....	12
2.4.3 Mooring forces	13
3 MODELLING APPROACH.....	17
3.1 Software	17
3.1.1 AquaSim.....	17
3.1.2 ShipX Vessel Responses Program.....	17
3.2 Barge model	18
3.2.1 Geometry and hydrostatics.....	18
3.2.2 Natural roll period	19
3.3 Modelling in AquaSim	20
3.3.1 Load calculation	20
3.3.2 Procedure.....	21
3.3.3 Properties for the time domain simulations.....	23
3.3.4 Barge constraints	24
3.3.5 Mooring line model.....	25
3.4 Modelling in ShipX.....	25
4 CASE STUDIES	27
4.1 Case study descriptions	27
4.2 Waves and current.....	27
5 SIMULATION AND RESULTS.....	29
5.1 Verification of movements.....	29
5.2 Study Case 1 – AHV close to OI.....	31
5.3 Study Case 2 – At drop point	34

5.4	Study Case 3 – Anchor in water	40
5.5	Case study 4 – Angled line with offset from centre	43
6	DISCUSSION	47
6.1	Software	47
6.2	Barge simplifications.....	47
6.3	Constraints.....	47
6.4	Differences in roll motion	48
6.5	Results	49
7	CONCLUSION AND FUTURE WORK.....	51
7.1	Conclusion.....	51
7.2	Future work	52
	REFERENCES	53
	APPENDIX A – MODEL INPUT.....	2
	APPENDIX B – CD.....	7
	APPENDIX C – ARTICLE DRAFT	9

List of figures

Figure 1.1 Bourbon Dolphin [www.maritimt.com] 1

Figure 1.2 Island Vanguard from Island Offshore. UT 787 DC design from Rolls-Royce... 2

Figure 1.3 Typical deck equipment found on board a AHTS vessel [4]..... 3

Figure 2.1 Vessel DOF when encountering wave[8] 5

Figure 2.2 Stable, neutral and unstable condition[5] 6

Figure 2.3 Illustration of a heeling vessel 7

Figure 2.4 GZ-curve for barge with GM=1.9m and weight 7380 ton..... 8

Figure 2.5 A vessel in a trimming condition, trimming forward 10

Figure 2.6 Strip theory.[6]..... 11

Figure 2.7 Back view of vessel 13

Figure 2.8 Side and top view of vessel..... 13

Figure 2.9 Side view of force components from the mooring setup 14

Figure 2.10 Aft end of a vessel with the force components 15

Figure 3.1 Components of a modelled Barge in AquaSim 18

Figure 3.2 Components of a modelled Barge in AquaSim 21

Figure 3.3 Cross section for Main element 22

Figure 3.4 Cross section for 2D hydrodynamic element..... 22

Figure 3.5 Weather loads as presented in AquaBase 23

Figure 3.6 DOF in nodes on Barge model. 1=free 0=locked 25

Figure 3.7 Drawing of hull geometry as presented in ShipX..... 26

Figure 4.1 Simple study cases of AH operation involving OI and AHV 28

Figure 4.2 Loading conditions for study case 4. Mooring line set at 60 and 36 28

Figure 5.1 Heave, roll and pitch comparison 30

Figure 5.2 Case #0 and #1 Comparison of pitch and roll motion at T=6.5s and T=7s. 32

Figure 5.3 Case #1. Pitch motion for T=6.5s and 7s seconds in beam sea. 33

Figure 5.4 Case #1. Axial force in mooring line acting on the stern in beam sea..... 33

Figure 5.5 Pitch and heave motion in head sea 36

Figure 5.6 Case #2. Roll-, pitch-motion and mooring line force at T=6.5s and 7s 37

Figure 5.7 Roll motion with amplitude 1 and 2. Case #2..... 38

Figure 5.8 Roll motion and mooring line force with varying amplitudes and with current. 39

Figure 5.9 Case #3. Pitch and Heave motions in head sea 41

Figure 5.10 Case #3. Roll-, pitch-motion and mooring line force in beam sea 42

Figure 5.11 Case #4. Roll- and pitch-motion with varying angle on mooring line 44

Figure 5.12 Comparison of roll motion for all study cases based on wave period. 45

List of tables

Table 2.1 Ship motions and DOF..... 5

Table 3.1 Barge geometry and hydrostatics 19

Table 3.2 Weather loads and description 23

Table 3.3 Time series setup in AquaBase 24

Table 3.4 parameters for anchor line..... 25

Table 3.5 parameters for work wire 25

Table 5.1 Wave headings and acting motions..... 29

Abbreviations

AHV/AHTS	Anchor Handling Vessel Tug Supply
BP	Bollard pull
CL	Centre line of vessel
DNV GL	Det norske Veritas Germanische Lloyd
DOF	Degree Of Freedom
FEA	Finite Element Analysis
G	Centre of Gravity
IMO	International maritime Organization
OI	Offshore Installation
IS code	Code on intact stability
K	Keel
M	Metacentre
NMD	Norwegian Maritime Directorate
RAO	Response Amplitude Operator
WL	Water line

Nomenclature

Symbol	Unit	Explanation
α	[deg]	Angle between mooring line force and aft end xz-plane
α_{xz}	[deg]	Angle between mooring line force and aft end in xz-plane
β	[deg]	Angle between mooring line force and centre line xy-plane
β_{xy}	[deg]	Angle between mooring line force and centre line xy-plane
Δ	[tonnes]	Displacement weight
∇	[m^3]	Displacement volume
ζ	[m]	Wave elevation
ζ_a	-	Wave amplitude
η_k	-	Vessel motion amplitude for given degree of freedom k
η_{ka}	[m]	Motion amplitude per unit wave amplitude for a given degree of freedom k
ρ	[$\frac{kg}{m^3}$]	Water density
θ	[deg]	Heeling angle
θ_k	[deg]	Phase angle for a given degree of freedom
ω	[rad/s]	Frequency of encounter
a_2	[m/s^2]	Fluid acceleration in local y-direction
A_r	[m]	Amplitude of the reflected wave
B	-	Centre of Buoyancy
B'	-	Centre of Buoyancy after heel
b	[m]	Breadth
Ca_y	-	Added mass in local y-direction
Cb	-	Block coefficient
C_{dy}	-	Drag coefficient in local y-direction
D	[m]	Depth
F_{drift}	[N]	Drift force
F_{ML}	[N]	Total mooring line force
$F_{ML,x}$	[N]	Mooring line force component in x-direction

$F_{ML,XY}$	[N]	Total mooring line force in xy-plane
$F_{ML,XYZ}$	[N]	Total 3-dimensional mooring line force
$F_{ML,Y}$	[N]	Mooring line force component in y-direction
g	[m/s^2]	Gravity
$\overline{GM}_T/\overline{GM}$	[m]	Distance from G to (transverse)metacentre
\overline{GZ}	[m]	Righting arm
I	[m^4]	Area moment of inertia
KB	[m]	Distance from keel to centre of buoyancy
KG	[m]	Distance from keel to centre of gravity
KM	[m]	Distance from keel to metacentre
L	[m]	Length
M_r	[N * m]	Righting moment
r_{44}	[m]	Radius of gyration/Roll radius
t	[m]	Draught
T	[s]	Wave period
$T_{roll,air}$	[s]	Natural roll period in air
u	[m/s]	Fluid velocity
\dot{v}_{2m}	[m/s]	Velocity at the element mid point in local y-direction
X_{AFT}	[m]	Longitudinal distance from G to aft position X
X_{TP}	[m]	Longitudinal distance from G to towing pin
Y_{SR}	[m]	Transverse distance from centre line to end of stern roller
Y_{TP}	[m]	Transverse distance from centre line to towing pin

1 Introduction

1.1 Background

Anchor Handling is one of the most complex operations done by offshore ships in the North Sea as it demands a lot from both crew and vessel. Under operation the vessel is affected by a number of different forces varying in both size and direction which puts high strain on structure and equipment as well as affecting the stability. One example of a real-life, worst case scenario happened in April 2007 when the AHTS vessel “Bourbon Dolphin” capsized while deploying an anchor for the semi-submersible rig “Transocean Rother” 75 nautical miles northwest from Shetland, resulting in the death of 7 people. The commission set up for the investigation highlighted several factors that contributed to the capsizing but in the end it was the loss of stability that caused it [1]. As a result of this the Norwegian Maritime Directorate proposed several changes in rules and standards to be implemented in the design process and operation of AHTS vessels to prevent similar situations to happen again. Simulations of AHV operations, with realistic models and cases, can be a great tool to predict and prevent accidents like this. This master thesis aims to investigate how these forces affects the stability under operation.



Figure 1.1 Bourbon Dolphin [www.maritimt.com]

1.2 Anchor Handling

1.2.1 Anchor Handling Tug Supply vessel (AHTS/AHV)

As the name suggests these are multi-utility vessels which are mainly built to handle anchors and performing towing operations. These operations are often related to oil rigs where towing them to their location to anchor them up are some of the main tasks however, they are also used to transport supplies between offshore installations and mainland as well as support in emergency situations at sea and performing ROV-services. Due to the nature of an AHTS vessels work, there are high requirements when it comes to manoeuvrability, stability, and pulling power/Bollard pull (hereby BP). There are three main types of anchor handling vessels (hereby AHV) [2]; the *North European Anchor Handling Tug*, the *Anchor Handling Tug and Supply Vessel* and the *American Anchor Handling Tug*. The two former represents the most common design for a typical AHV while the latter one represents the classic smaller tug boat design. The vessel design is characteristic and with a steering house, and winch house in front of a large deck area with barriers on the side to protect the crew and equipment. The stern is open and enforced with a stern roller to handle chains grinding on the edge. Further explanation of the equipment is found later in this chapter. The length can vary from 50 metre to well over 100 m with a width of 15-25 metres. Bollard pull can vary from 60 tonnes on the smallest ones to over 400 tonnes on the bigger and most advanced ships.



Figure 1.2 Island Vanguard from Island Offshore. UT 787 DC design from Rolls-Royce. [3]

1.2.2 Equipment

An AHTS vessel holds a large amount of equipment which makes it a very versatile resource. Figure 1.3 gives an overview of some of the equipment used in anchor handling and tug-operations with explanations following below.

1. Stern Roller- One or more large cylindrical roller mounted at the aft part of the AHTS to prevent excessive damage to the stern caused by chains, anchors, hoses etc.
2. Storage winches/Working line – Usually contains both the anchor handling drums and towing drums which are normally connected to the same drive system. The work wire is used for deploying and retrieving the anchor as well as towing operations.
3. Stop pins – Adjustable pins for centring the wires.
4. Shark Jaw - The shark jaw is a device for connecting and disconnecting chain and wires, in addition to securing chain sections on the deck

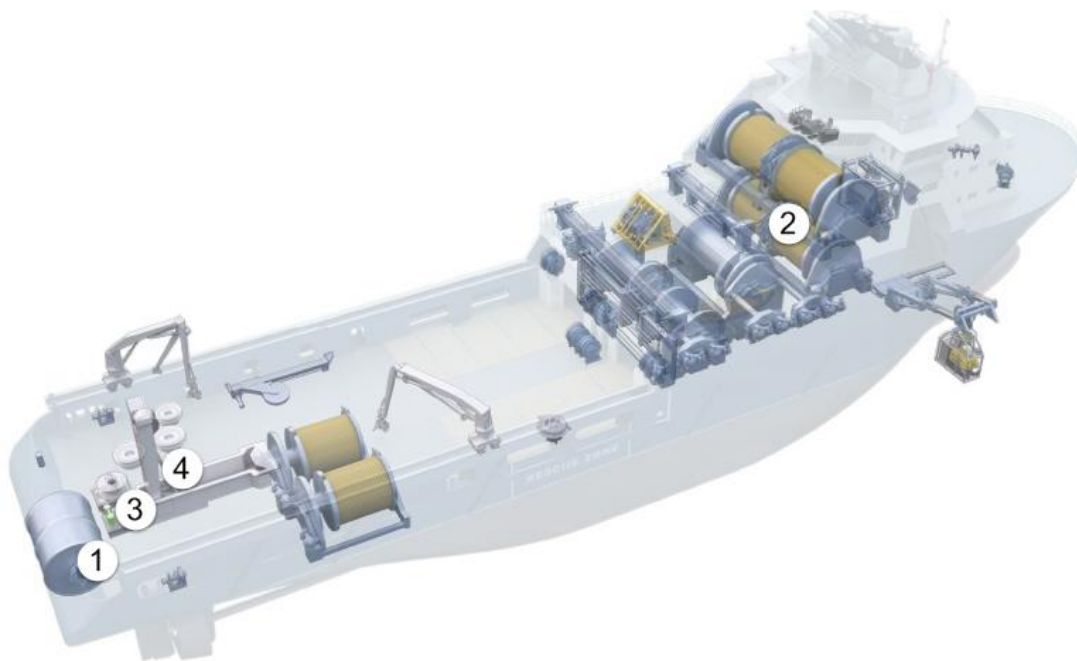

Figure 1.3 Typical deck equipment found on board a AHTS vessel [4]

1.2.3 Anchor handling operation

Like many operations done at sea, anchor handling is not done by following one procedure every time as it depends on the complexity of the task and the environment in which the operation is done. The procedure is often discussed and planned before the operation where critical factors such as anchor handling, rig movement and vessel manoeuvring are considered.

Sometimes a secondary vessel is necessary to execute the operation depending on the capacities and nature of operation. In this section this operation will be explained briefly.

Deploying anchor

Deployment of the anchor is often done by the vessel towing the anchor line from the rig to a given position. At the position the anchor is connected and lowered into the ocean using the working line from the winch. The weather condition is critical as the AHV is already exposed to large forces from the anchor line, depending on the length of the line. To handle the addition of waves, current and side winds it is critical for the vessel to have enough stability. [2]

Recovering anchor

The recovery of the anchor is more or less the reverse process of deploying it. The AHV drag the anchor loose from the seabed and starts to winch up the anchor and simultaneously reversing as the rig pulls the mooring line [15]

2 Background theory

In this chapter some of the basics of static and dynamic stability, vessel motion and wave theory will be explained.

2.1 Definition of motions

A vessel floating in water has 6 degrees of freedom containing 3 translation movements and 3 rotational movements, described as shown in Table 2.1 and Figure 2.1. These motions can be considered in combinations with each other, coupled, or individually, uncoupled.

Table 2.1 Ship motions and DOF

Term	Denotation	Motion	Direction
Surge	η_1	Translation	X
Sway	η_2	Translation	Y
Heave	η_3	Translation	Z
Roll	η_4	Rotation	X
Pitch	η_5	Rotation	Y
Yaw	η_6	Rotation	Z

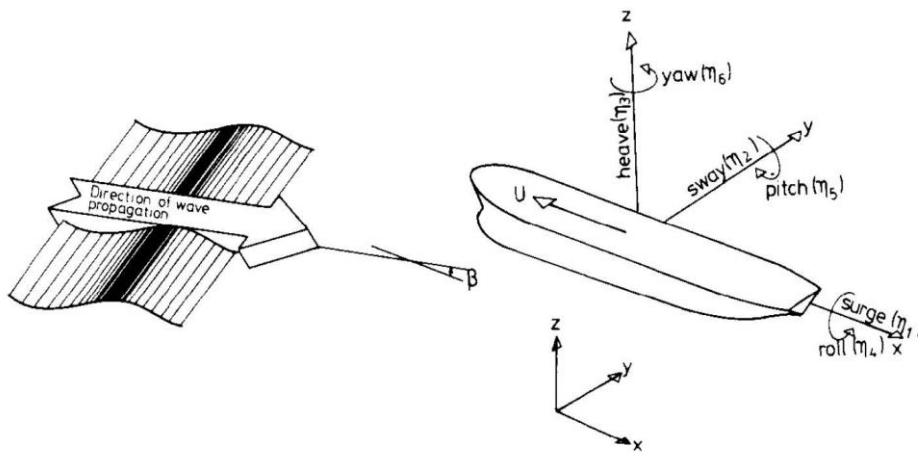

Figure 2.1 Vessel DOF when encountering wave[8]

2.2 Stability

The concept of stability can be difficult to define but the simplest way would be to consider a floating, resting body where an applied force or moment causes the body change its position in some way. From this point one can assume that one of these three situations will occur when the force or moment is removed:

- The righting arm of the body will force the body back to its initial position; the equilibrium is stable
- The position of the body continues to change; the equilibrium is unstable and the body can capsize.
- The body remains in its new position but the smallest influence will change it again either way; the equilibrium is neutral.

These three situations can be explained visually in Figure 2.2

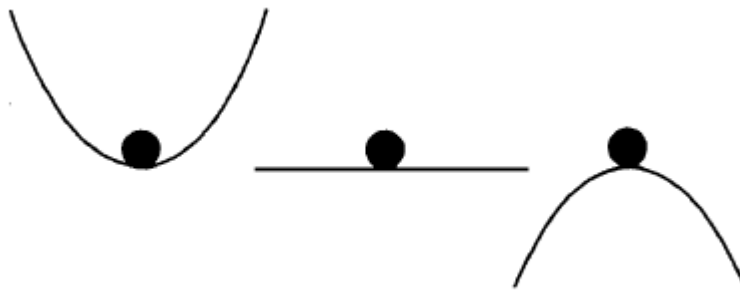

Figure 2.2 Stable, neutral and unstable condition[5]

If the vessel is floating and resting in fluid, it means that the sum of all acting forces are equal to zero, the body has reached equilibrium. Regarding the force equilibrium there are three conditions that needs to be fulfilled [5]:

1. Horizontal equilibrium where the sum of all the horizontal forces are equal to zero
2. Vertical equilibrium where the sum of gravity force and buoyancy force are equal to zero.
3. Rotational equilibrium where the sum of all moments about the centre of gravity (hereby G) another given point are equal to zero and the vessel is floating upright and balanced.

2.2.1 Righting moment

When considering the transverse stability of a vessel there are some key reference positions along the centreline that are used to explain the concept. K is the keel and is in most cases the lowest point on the hull or at least amidships. The vessel is kept floating by the buoyancy (B) created by the displaced volume from the hull. G should be constant unless there are free moving weights on board. When the rotational equilibrium is fulfilled, G is acting in a straight line right through B. If the vessel is affected by a force acting outside the centreline the added moment will cause it to rotate about its longitudinal axis, known as heeling. When this happens the transverse shape from the hull in water will change, forcing the centre of buoyancy B to move to one side B'. From B' one can now consider a new line acting from this point perpendicular to the "new" waterline intersecting the centreline in the point M called the metacentre, which will be explained later in this chapter. Figure 2.3 shows a typical representation of a vessel heeling, in this case a rectangular barge.

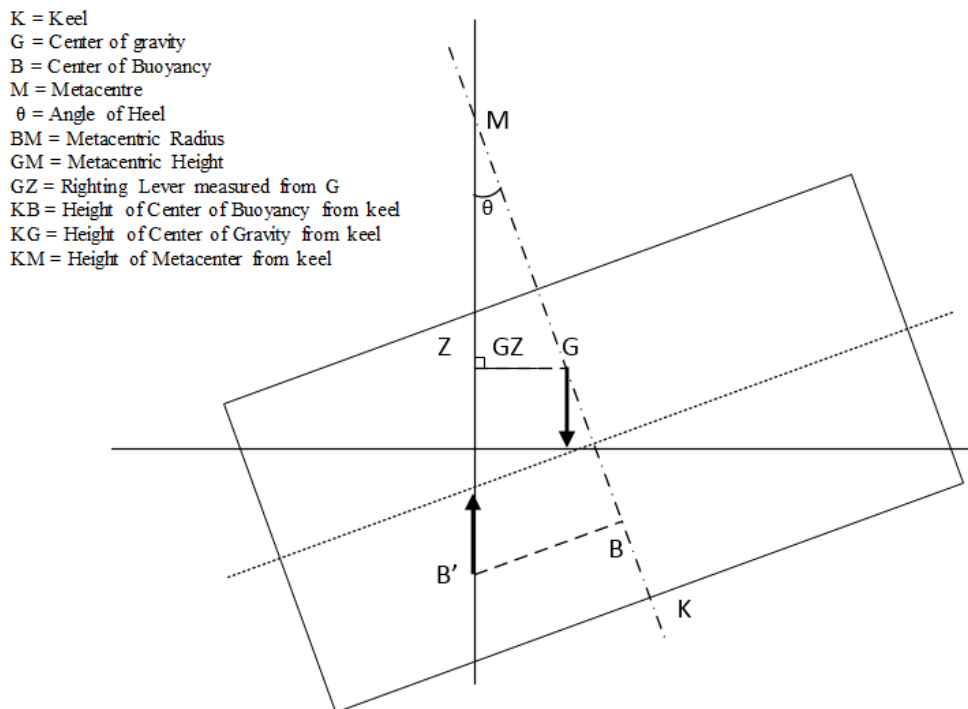

Figure 2.3 Illustration of a heeling vessel

As there is now a horizontal distance between G and the new centre of buoyancy B', there is a righting moment acting on the vessel:

$$M_r = \rho g \nabla * \overline{GZ} \quad (2.1)$$

where \overline{GZ} is the horizontal line from G to a point Z on the acting direction from B', the righting arm. The GZ distance is an important parameter when it comes to stability calculations and is for small heel angles found as:

$$\overline{GZ} = \overline{GM} \sin \theta \tag{2.2}$$

Which inserted into (3.1) gives the righting moment as:

$$M_r = \rho g \nabla * \overline{GM} \sin \theta \tag{2.3}$$

2.2.2 GZ-curve

The stability of a vessel is often presented by a GZ-curve as it describes shows the relation between the heel angle and righting arm, GZ. The area under the curve describes the vessels ability to restore itself from a heel, or its restoring potential energy. From the curve one can get all necessary data regarding stability criteria as it shows the maximum GZ and at what heeling angle it occurs on and GM. Figure 2.4 presents the GZ-curve for the barge in this report.

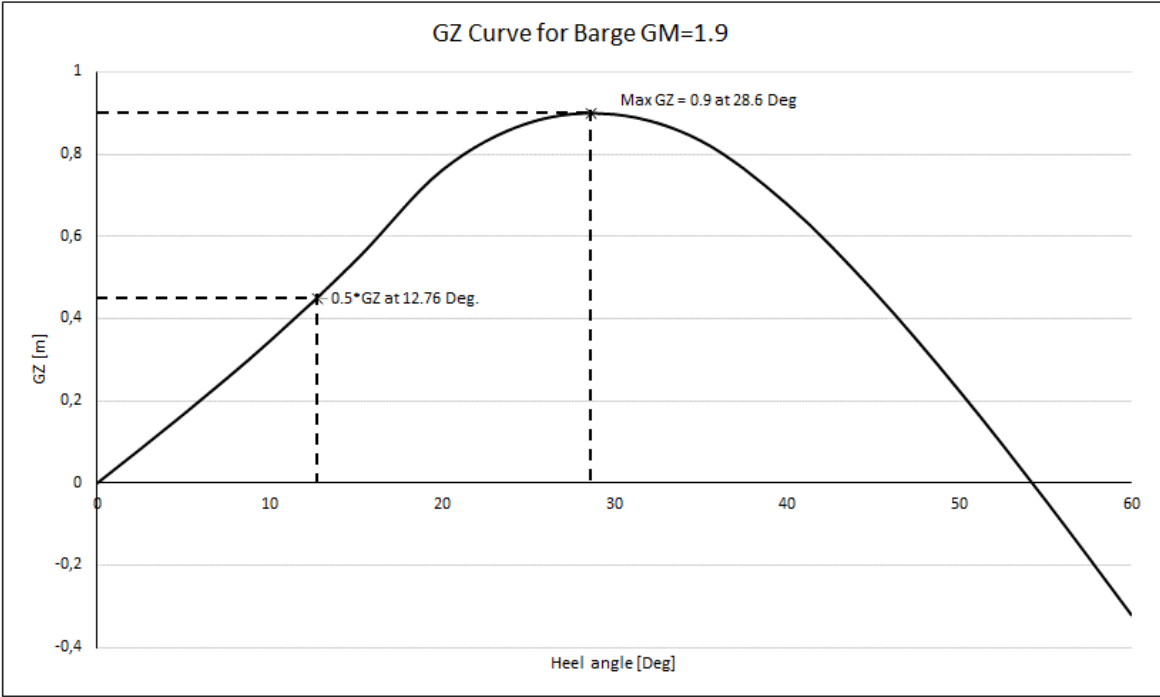

Figure 2.4 GZ-curve for barge with GM=1.9m and weight 7380 ton.

2.2.3 Metacentre

The metacentre M is in a stable condition the top point of the vector \overline{GM} and is the intersection between the lines from B in an upright position and the new B' occurring at a heeling angle θ .

The distance GM is referred to as the metacentric height and is used to describe vessels stability. The larger GM the more stable is the vessel. For small heeling angles, M can be considered constant [5,7] making GM constant as well and is then referred to as the initial metacentric height, GM0. For small heeling angles it can then be assumed that:

$$GM = GM_0 \tag{2.4}$$

The distance from the centre of buoyancy to the metacentre, \overline{BM} , is called *the metacentric radius* and is given as

$$\overline{BM} = \frac{I}{\nabla} \tag{2.5}$$

Where I is moment of inertia of the water plane about the axis of heeling and ∇ is the displaced volume from the hull. Together, these different vectors make up the full distance between the keel and the metacentre and are important parameters in calculating stability. The relation between them can be found through simple equations:

$$\begin{aligned} GM &= KM - KG \\ KM &= KB + BM \end{aligned} \tag{2.6}$$

As the formulas underline the importance of the centre of gravity placement as a lower KG gives a higher GM which results in a more stable ship. The preferred value of GM varies between different types of vessels.

2.2.4 Longitudinal stability

In terms of longitudinal stability, the principle is the same with similar parameters having the same physical relations. The biggest difference is the introduction of the longitudinal centre of flotation LCF which is the point in which the vessel rotates about as a result of it not being symmetric longitudinally, about the YZ plane. This point is found at the centre of the water plane area in the floating condition. A vessel in lightship condition may then have a small trim, often tilted forward depending on ship type. For a standard PSV (Platform Supply Vessel) for instance, it is expected to carry some weight on deck and floats with a slight trim forward when unloaded and may float in with no trim (“even keel”) when loaded. Since the length of the vessel is much greater than the beam the waterline is of course longer leading to a much higher metacentre and moment of inertia however, the longitudinal stability has no great effect on the vessels and crew safety as the pitching motions are relatively small. There is therefore very

unlikely that a vessel will capsize as a result of the trimming moment. Figure 2.5 shows a simple drawing of a trimming vessel.

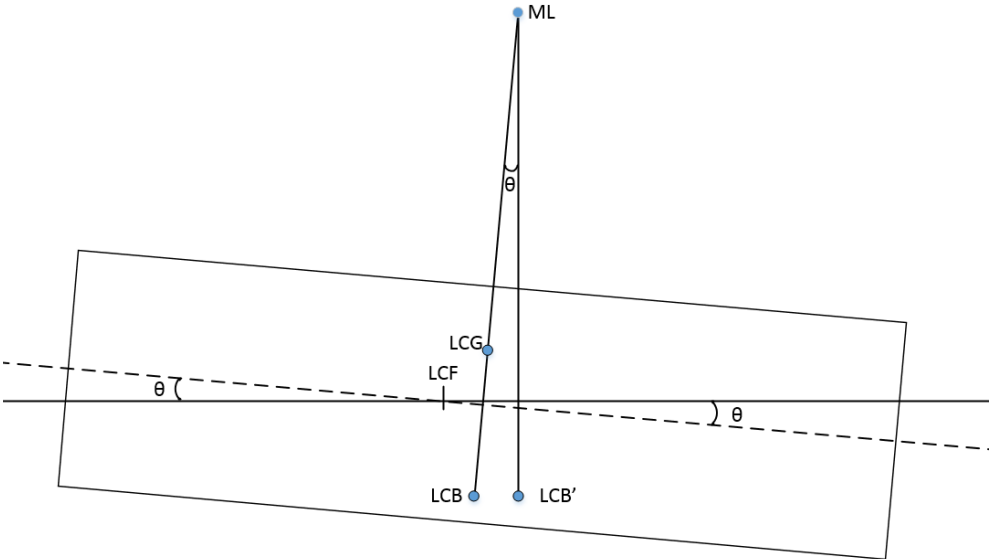

Figure 2.5 A vessel in a trimming condition, trimming forward

2.3 Vessel response

In this chapter some basic theory about ship movements relevant to this project will be explained.

2.3.1 Response in regular waves

When a vessel encounters a wave it will be displaced in one or several directions depending on the direction of the wave. For regular waves the elevation of this wave can be defined as [8]

$$\zeta = \zeta_a \sin(\omega t) \tag{2.7}$$

where ζ_a is the amplitude of the wave and ω is the wave frequency.

In any given reference point on the vessel, i.e. the LCG, there will be a displacement as a reaction to the vessel encountering the wave. This displacement will be slightly different from the wave elevation and the relation between these two can be described by response amplitude operators (RAO) or mathematically Transfer functions given as

$$\eta_k(t) = \eta_{ka} \cos(\omega t + \theta_k), \quad k = 1, \dots, 6. \quad (2.8)$$

where η_{ka} is the motion amplitude per unit wave amplitude and θ is the phase angle¹.

2.3.2 Strip Theory

The principles of Strip Theory, or 2D Potential Theory makes it possible to determine forces and motions on a three-dimensional floating body by considering the body being made up of several two-dimensional sections, or strips, which in all together make up the whole shape of the hull. According to [5], each of these sections can be considered treated as a section of a floating, infinitive cylinder with a linear boundary problem and hydrodynamic effects calculated and solved for each of them. This is visualized in Figure 2.6.

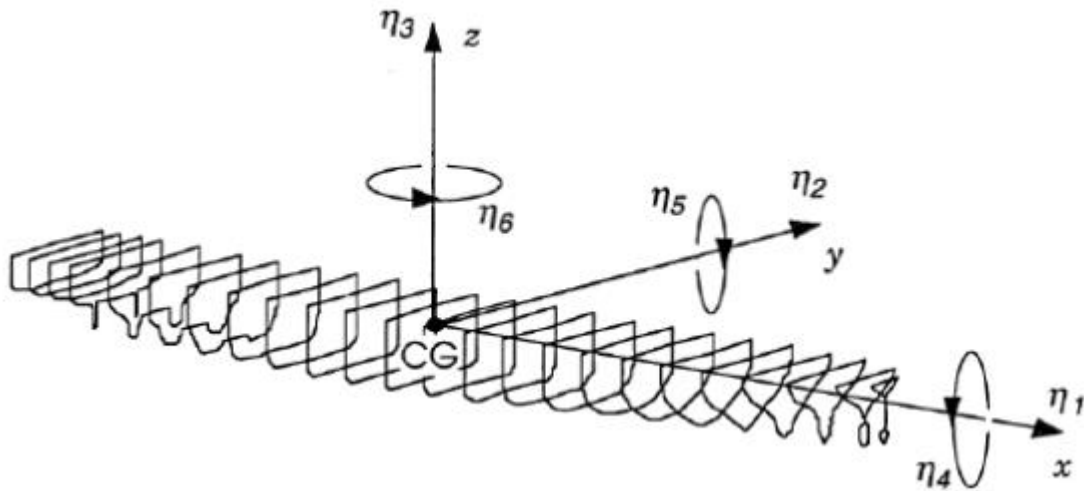

Figure 2.6 Strip theory.[6]

2.4 Stability criteria

After the Bourbon Dolphin incident, a commissions from the NMD came up with several proposals to prevent similar accidents from happening. In this chapter the new and current stability criteria will be presented and briefly explained.

¹ The phase angle tells the phase relationship, or timing between the vessels motion relative to the wave. i.e. a phase angle of +-180 degrees means response is opposite of the wave elevation and 0 degrees means that those two are in phase [8]

2.4.1 General stability criteria

In the DNVGL rules and standards documents [9], the following requirements apply for all vessels above 24 m:

- “The area under the righting lever curve (GZ curve) shall not be less than 0.055 metre-radians up to $\theta = 30^\circ$ angle of heel and not less than 0.09 metre-radians up to $\theta = 40^\circ$ or the angle of flooding θ_f if this angle is less than 40° . Additionally, the area under the righting lever curve between the angles of heel of 30° and 40° or between 30° and θ_f , if this angle is less than 40° , shall not be less than 0.03 metre radians”
- “The righting lever (GZ) shall be at least 0.20 m at an angle of heel equal to or greater than 30° .”
- “The maximum righting lever should occur at an angle of heel preferably exceeding 30° but not less than 25° ”
- “The initial metacentric height, GM_0 shall not be less than 0.15 m.”

2.4.2 Special criteria for AHTS

In the proposed regulations the NMD address the importance of doing the necessary calculations for vessels used for anchor handling involving use of towing winch to show both acceptable and the critical conditions for “vertical and horizontal transverse force/tension and as a minimum include the following [9,10]:

When affected by the maximum acceptable tension in the wire/chain including the maximum transverse force/tension, the maximum acceptable heeling angle should be limited to one of the following angles that occurs the first:

- 15° degrees heeling angle.
- The flooding angle, which means green water emerging on the deck.
- Angle equal to 50 % of maximum GZ

They recommend that the heeling moment and righting arm are to be considered from the upper and outer edge of the stern roller when the tension force is to be calculated. The key angles and parameters is presented in Figure 2.7 and Figure 2.8.

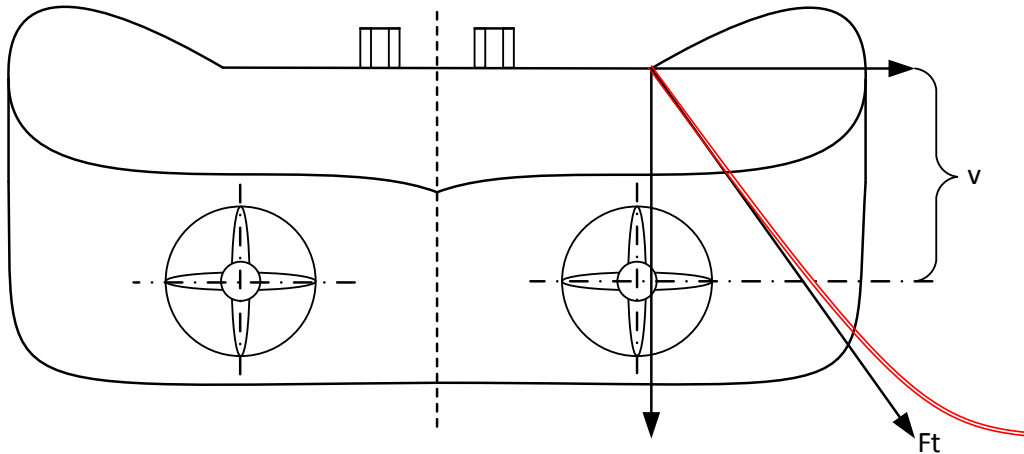

Figure 2.7 Back view of vessel

F_t is the tension force in the mooring line and v is the vertical distance of the horizontal force component relative to the centre of thrust and y is the horizontal distance of the mooring line relative to the vessels centre line.

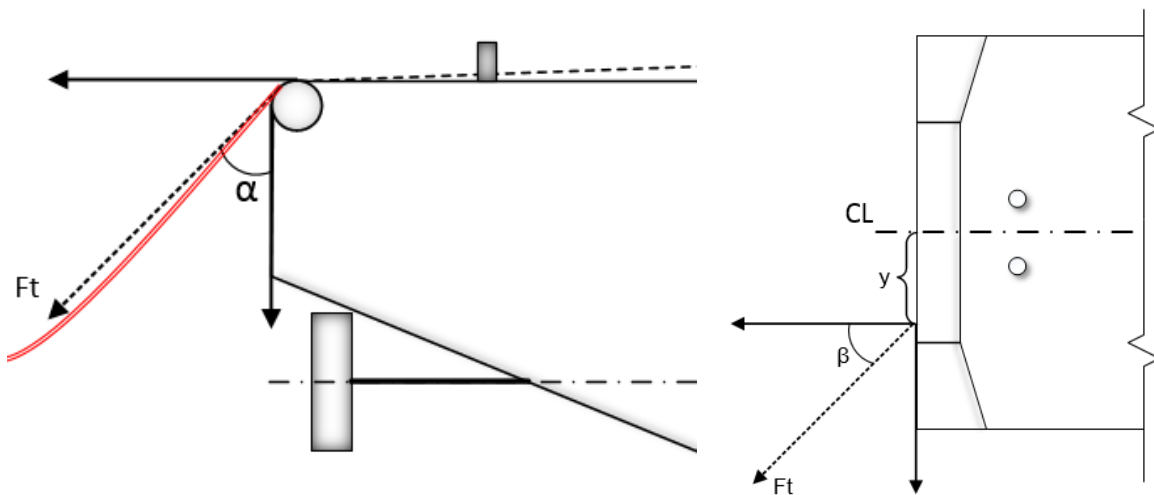

Figure 2.8 Side and top view of vessel

2.4.3 Mooring forces

As the mooring line is often subject to great tension force and acting from varying angles it is considered a critical factor when it comes to the stability of an AHV. The force acting in the mooring line is more dynamic rather than static and varies by the amount of wire released and environmental forces such as waves and current. As mentioned the line of attack from the mooring line may vary and affect the ship in several ways, most notably by heel and trim. The

ship will also experience being pulled backwards which means extra requirements when it comes to bollard pull. Figure 2.9 shows a vessel seen from starboard (XZ-plane) showing the force components from the mooring line.

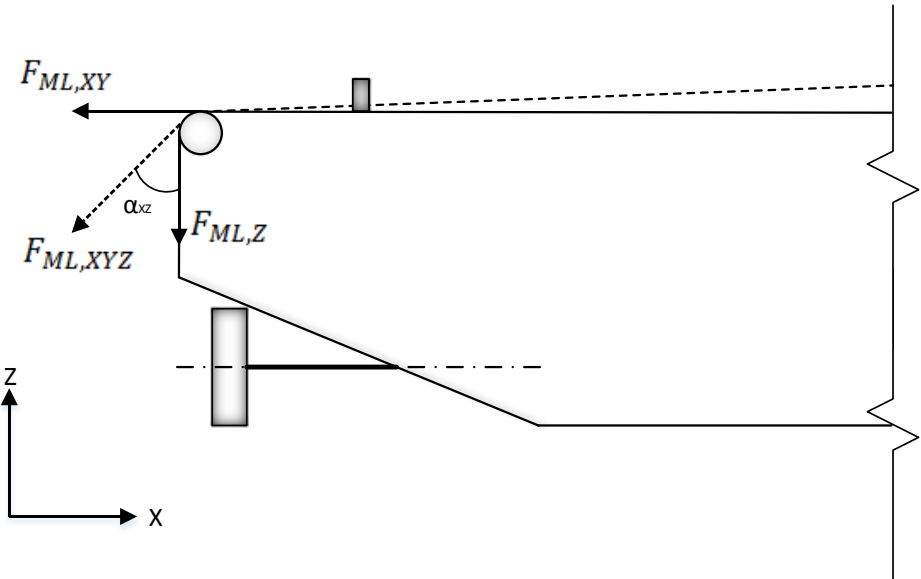

Figure 2.9 Side view of force components from the mooring setup

The total force from the mooring line in the three dimensional space is found as

$$F_{ML,XYZ} = F_{ML} \tag{2.9}$$

Which can be decomposed into the horizontal and vertical force components

$$F_{ML,XY} = F_{ML} \sin(\alpha_{XZ}) \tag{2.10}$$

$$F_{ML,Z} = F_{ML} \cos(\alpha_{XZ}) \tag{2.11}$$

Where α_{XZ} is the angle between the direction of the total force and the vertical force component in the XZ-plane.

Figure 2.10 shows the vessel seen from above and the force components are now considered in the XY-plane. For this explanation the force components are somewhat simplified as there are other factors contributing to the final angle of attack of the force, such as the changing angle of the mooring line at the starboard stopping pin. Friction is also neglected in the calculations so there is no force on the stern roller.

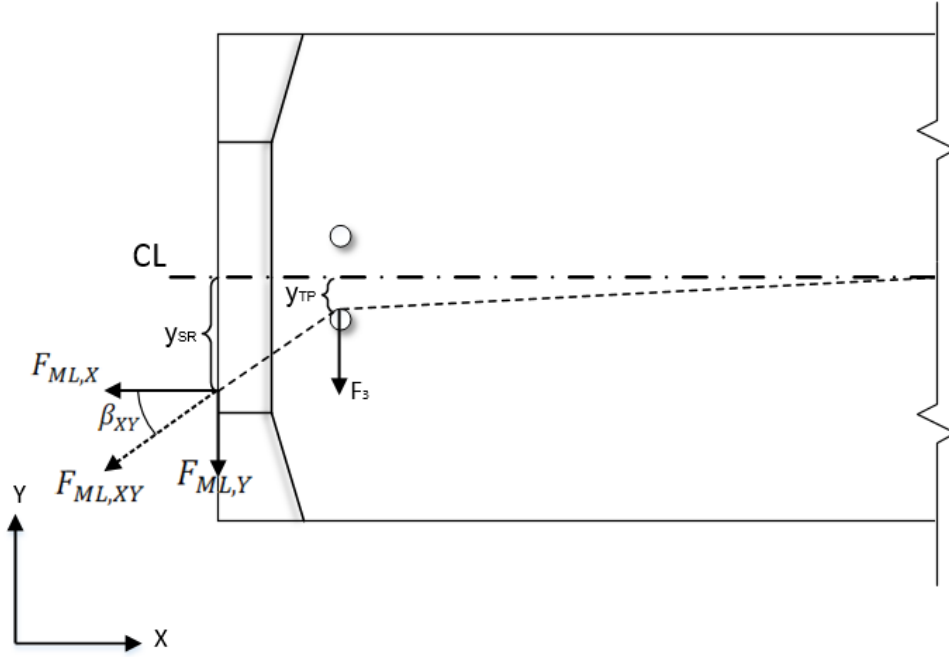

Figure 2.10 Aft end of a vessel with the force components

So based on the equations 2.9-2.11 in the previous section, the new force components are found as

$$F_{ML,X} = F_{ML,XY} \cos(\beta_{XZ}) = F_{ML} \sin(\alpha_{XZ}) \cos(\beta_{XZ}) \quad (2.12)$$

$$F_{ML,Y} = F_{ML,XY} \sin(\beta_{XY}) = F_{ML} \sin(\alpha_{XZ}) \sin(\beta_{XY}) \quad (2.13)$$

The distance y from the centre line and the force is a vital parameter when considering the effect from the mooring line as it will create a rotational moment on the vessel. The force $F_{ML,Z}$ is acting downwards on the stern roller with a distance X_{AFT} from G and has a distance Y_{SR} from the centre line. The distance is found by

$$Y_{SR} = X_{TP} \tan(\beta_{XY}) + Y_{TP} \quad (2.14)$$

Where β is considered equal to the rotation of the ship, yaw-angle. If the angle of attack from the winch is considered small there will only be one force component acting from the winch, acting in x-direction towards the stern. The sum of forces then makes this force equal to $F_{ML,X}$. As there are no considerable force components acting from the winch in y-direction, the sum of forces then gives

$$F_{ML,Y} = F_3 \quad (2.15)$$

3 Modelling approach

In this chapter the software used in the project is presented and process of dimensioning and modelling the barge is explained.

3.1 Software

3.1.1 AquaSim

AquaSim is a time-domain Finite Element Analysis-tool developed by Trondheim based Aquastructures AS. The software is aimed at both stiff and flexible marine constructions subject to static and dynamic loads from winds, waves, currents etc. In AquaSim one can execute time simulations and investigate the interaction between stiff and flexible elements of different types and typical cases are operations involving mooring, towing and heavy lifting. AquaSim consist of the current modules which are used in this project:

- **AquaEdit** – Creating geometric models [11]
- **AquaBase** – Define material and hydrodynamic properties to the models [12]
- **AquaSim solver** – Derive results from AquaBase from time domain simulations [13]
- **AquaView** – Shows the results in 3D [14]

The models made in AquaSim can consist of different element types such as Beam and Truss which are used in this project. The elements are modelled as simple lines between to two nodes and then given the necessary properties. Beam elements are as the name suggests structural objects such as beams and bars which can be subject to bending stress. Truss elements are used to define objects used for mooring such as ropes, chains and others. These elements are given pre-defined or custom properties regarding mechanical attributes, cross-section, material, load parameters depending on what is to modelled.

3.1.2 ShipX Vessel Reponses Program

ShipX VERES is a software developed by MARINTEK to calculate and analyse ship motions and global loads for aid in the design process of ships. The program uses linear, potential, Strip Theory to calculate the hydrodynamic loads on any given hull. The hull is imported or created in the program and is defined by several sections resembling its shape. Input is given regarding ship geometry, loading condition, velocity and wave direction which is used by the Main Program to calculate the transfer functions for the ship motions and loads. For making reports, plot results for presentation, the Postprocessor will execute this and do further calculations. For more information, see [8,16].

3.2 Barge model

3.2.1 Geometry and hydrostatics

For investigating the dynamic effects that a mooring line has on a AHTS one has to set up a realistic scenario with all the necessary elements involved in an anchor-handling operation. Due to limitations in the software a less complex model has to be used thus a barge with similar dimensions were chosen. A simple barge is modelled in AquaSim and compared with an identical model in ShipX and used for the analysis. The main dimensions of the barge are chosen to replicate similar sized offshore-vessels and can be found in below.

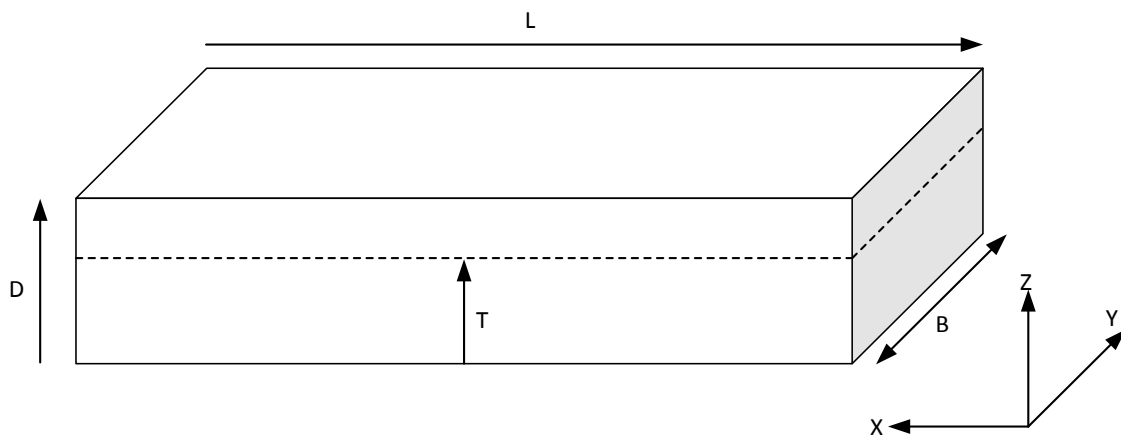

Figure 3.1 Components of a modelled Barge in AquaSim

As a barge is can be considered more or less as a rectangular box, its initial stability can be found by simple formulas by using either weight or draft as constant.

Due to its shape a barge will have a block coefficient², C_b close or equal to 1 and

To find the GM of the barge one must know the components that it consists of which is governed by the shape and mechanical attributes where we have the relation mentioned in equation 2.5

$$BM = \frac{I}{\nabla}$$

Which I for a boxed-shape barge is found as

$$I = \frac{B^3L}{12} \quad (3.1)$$

² The Block Coefficient C_B is the ratio between the displaced volume divided by $B_{WL} \times L_{WL} \times t$. The latter parameters define a box around the submerged body of the vessel which the block coefficient shows how much is “occupied” by the displaced volume.

Which shows the importance of the breadth is for the initial stability. Furthermore, the displaced volume is defined as

$$\nabla = BLt \quad (3.2)$$

From this the weight Δ can be found by multiplying the volume with the water density ρ and the other way around for finding the volume if the weight is known. The properties of a box-shaped Barge of considerable size makes it very stable in water as it has a GM much higher than what is found on vessels with more hydrodynamic shape. Based on the formulas explained earlier, the main dimensions are chosen with respect to the GM. The dimensions are presented in Table 3.1

Table 3.1 Barge geometry and hydrostatics

Parameter	Abbr.	Value
Length	L	80 [m]
Breadth	b	18 [m]
Depth	D	8 [m]
Draught	t	5 [m]
VCG	-	6 [m]
GMt	-	1.9 [m]

3.2.2 Natural roll period

When analysing the motions of a vessel some awareness of the natural period is necessary. The natural period can in this case be defined as the period in which the vessel oscillates. When a wave approaches with a period close to the natural period of the vessel the response can increase dramatically. In a plot of RAO data, the natural period can be identified where the peak of the curve is. To make accurate predictions of the natural period for all the vessels motions, stiffness and mass effects from the vessel floating should be included, such as added mass³. According to [17] an estimate can be done for the natural roll period in air, excluding added mass:

$$T_{roll_air} = 2\pi * \sqrt{\frac{r_{44}^2}{GM_t * g}} \quad (3.3)$$

Where r_{44} roll radius of gyration which for a barge is set as the breadth divided by four.

For the barge with the given dimensions and \overline{GM}_T the natural roll period can be estimates as

³ Added inertia due to the vessel accelerating and displacing water as it moves through it. Different for each motion(DOF)

$$T_{roll_air} = 2\pi * \sqrt{\frac{4.5m^2}{1.9m * 9.81 m/s^2}} = 6.55s$$

3.3 Modelling in AquaSim

This chapter presents the modelling procedure of the barge and mooring line. These models consist of beam and truss elements respectively and are defined by the given properties:

- Properties to the mechanical properties of an element
- Properties related to the cross section
- Properties related to how elements respond to loads

The given properties for the models can be found in Appendix A.

3.3.1 Load calculation

In AquaSim there are two load definitions that can be applied to the given elements; Hydrodynamic load and Morison submerged load definition. With Hydrodynamic load, linear strip theory is used as described earlier in this report. This is typically used for floating elements like a barge in this case.

Morison load definition is applied to submerged elements with small diameter relative to the wave length and is used for calculating loads from current and waves acting on threads, cables and anchor lines [18]. The equation is implemented in AquaSim as following:

$$F_2 = \frac{\rho_w C_{dy} Diam_N L_0}{2} (u_2 - \dot{v}_{2m}) \sqrt{(u_2 - \dot{v}_{2m})^2 (u_3 - \dot{v}_{3m})^2} + \rho_w (1 + C_{a_y}) V_{2D} L_0 a_2 - \rho_w C_{a_y} V_{2D} L_0 \ddot{v}_2 \quad (3.4)$$

Where C_{dy} is the drag coefficient in local y-direction, $Diam_N$ is the diameter of the cross-section in the direction of the relative velocity $\sqrt{(u_2 - \dot{v}_{2m})^2 (u_3 - \dot{v}_{3m})^2}$ vector in the cross-sectional plane. u_2 is the combination of fluid velocity due to waves (u_{2wave}) + current velocity in the local y-direction ($u_{2current}$), \dot{v}_{2m} is the velocity at the element mid point in local y-direction, a_2 is the fluid acceleration in local y-direction, $(1 + C_{a_y})$ is the mass coefficient with C_{a_y} being the added mass coefficient. As presented the equation consists of three parts:

- The first part of this equation is the drag part

- The second is the Froude Kryloff⁴ part and diffraction part of the load
- The third part is the added mass

The force component in z-direction is calculated in a similar way.

3.3.2 Procedure

When modelling a barge for mooring analysis in AquaSim, a specific procedure is used according to [19] which is explained in this chapter. This procedure shows that the barge consists of several parts; Main beam element, a 2D hydrodynamic beam element and so called “Dummies” for mooring points. The assembly of these elements is shown in Figure 3.2.

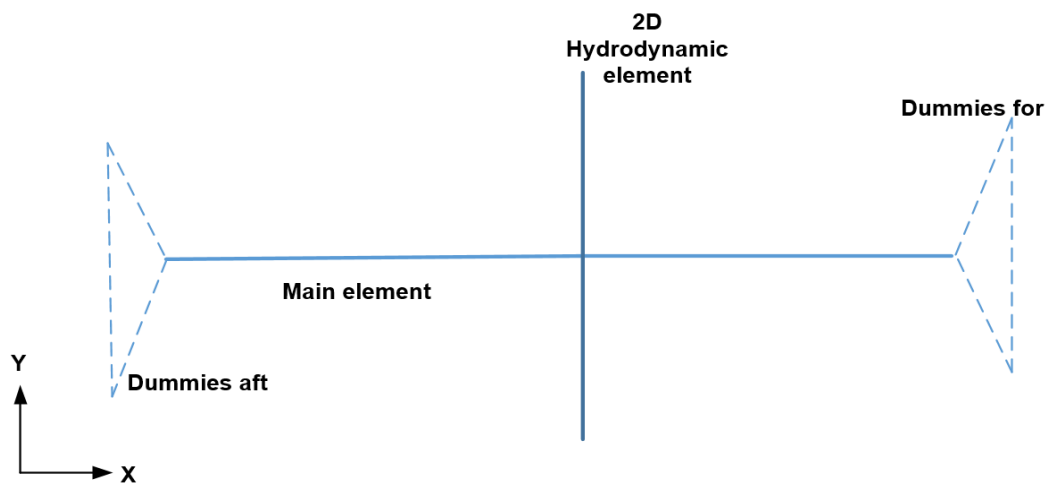

Figure 3.2 Components of a modelled Barge in AquaSim

Both the main element and 2D hydrodynamic element are defined as “hydrodynamic elements” which means that the hydrodynamic loads is calculated by linear strip theory. Drift forces are also chosen for these two elements and is defined as [18]:

$$F_{drift} = \frac{\rho g}{2} * A_r^2 \quad (4.4)$$

Where A_r is the amplitude of the reflected wave. For regular waves this is a constant force

Main element

The main beam element is modelled with the length of the barge with a cross-section representing the rest of the barge as shown in Figure 3.3. As the element is modelled in the

⁴ The Froude–Krylov force does, together with the diffraction force, make up the total non-viscous forces acting on a floating body in regular waves. The diffraction force is due to the floating body disturbing the waves

water line the coordinates represents how the barge is floating in water, with the negative Z-coordinate representing the draft and the positive representing the freeboard.

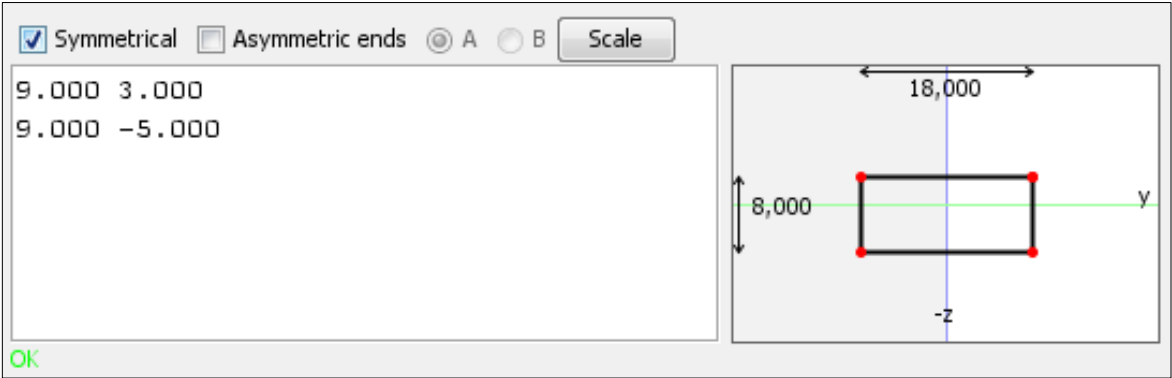

Figure 3.3 Cross section for Main element

2D-Hydrodynamic element

The 2D hydrodynamic beam element is modelled perpendicular to and across the middle of the main beam with the length equal to the width of the main beam and width equal to the length of the main beam. Figure 3.4 presents the cross section of this element.

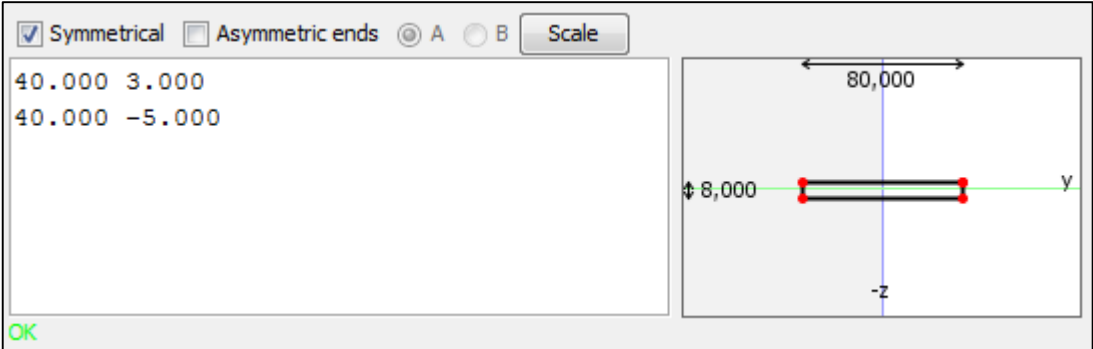

Figure 3.4 Cross section for 2D hydrodynamic element

The “2D Hydrodynamic, horizontal loads only” is checked for this element. This means that only the horizontal components of the hydrostatic and hydrodynamic forces are considered and is done to make the barge able to handle waves from all directions within one analysis model [21]. This element will therefore not add buoyancy to the model.

Dummies

The “Dummies” are modelled as beam elements with mooring points but without visual cross-section data and volume and defined with Morison load.

Environmental loads

The environmental loads, is given as “Normal”, where directions are based on the global coordinate system [21]. All of the weather parameters are chosen in the same menu as shown in Figure 3.5. Each line represents a load condition run with the chosen loads. These parameters are as presented in Table 3.2

Table 3.2 Weather loads and description

Property	Unit	Description
Nr.	-	Order of the load condition
Amp	m	Wave amplitude
T	Sec	Wave period in seconds
V	deg.	Wave direction from global positive x direction
c(x)	m/s	Current velocity in x-direction
c(y)	m/s	Current velocity in y-direction
w(x)	m/s	Wind velocity in x-direction
w(y)	m/s	Wind velocity in y-direction
Comment	-	Description of the load condition
Group	-	Group number if several analyses are to be executed

The environmental loads menu is as presented in Figure 3.5. Different conditions can be set with varying wave periods

<input type="checkbox"/>	Nr	Amp.	Tp	V	cX	cY	wX	wY	Comment
<input type="checkbox"/>	1	1	4.0	90.0	0	0	0.0	0.0	*Regular Wave*
<input type="checkbox"/>	2	1	4.5	90.0	0	0	0.0	0.0	*Regular Wave*
<input type="checkbox"/>	3	1	5.0	90.0	0	0	0.0	0.0	*Regular Wave*
<input type="checkbox"/>	4	1	5.5	90.0	0	0	0.0	0.0	*Regular Wave*
<input type="checkbox"/>	5	1	6.0	90.0	0	0	0.0	0.0	*Regular Wave*

Figure 3.5 Weather loads as presented in AquaBase

3.3.3 Properties for the time domain simulations

The time series analysis is set up in AquaBase as presented in Table 3.3. A pre-increment of 5 seconds is chosen as default and basically means that the environmental loads will build up in steps from 0 to the given value during the first 5 seconds into the simulation. If the current is set to 1 m/s then it will be 0 at step 1, 0.2 at step 2 etc. until it reaches 1 at step 5. The number of maximum iterations is set to the upper limit of 10000 to avoid diverging and make sure that the results are valid. The number of time steps set for one wave is set to a minimum of 12 seconds with a total number of steps set to 360, meaning there will be simulated a total of 30

waves after the incremented time. The number of total steps is varied between some load conditions due to either convergence problems or the fact that for some load conditions the amplitudes took longer or shorter time to stabilize. The wave profile is set as -1 meaning that the formula for infinite water depth is used. A positive number means the formula for finite depth is used [21].

Table 3.3 Time series setup in AquaBase

Time series	
Pre-increment	5
Max iterations per step	10000
No. Total steps for waves	360
No. Steps for one wave	12
Convergence criteria	1
Depth (wave profile)	-1

3.3.4 Barge constraints

As explained in the motion chapter a free floating vessel has 6 degrees of freedom as it can translate and rotate freely along and about the x-, y- and z-axis. Assigning DOF's to a model can be challenging as it is not always clear which nodes should be locked, and to what degree, to get the realistic behaviour of the model. The barge consists mainly of a longitudinal and transverse element which creates a natural set of end nodes and an intersecting point in the middle, which for the barge is also G. Two additional nodes are added with constraints to simulate thrusters counteracting the rotational moment from the mooring line. The idea is also that potential thrust forces from these can be read from these nodes. The complete DOF-configuration is presented in Figure 3.6. The end-nodes of the 2D-hydrodynamic element had to be locked for x-translation and z-rotation as there were some issues with the model splitting up after a certain amount of simulation time. This is elaborated further in the discussion-chapter.

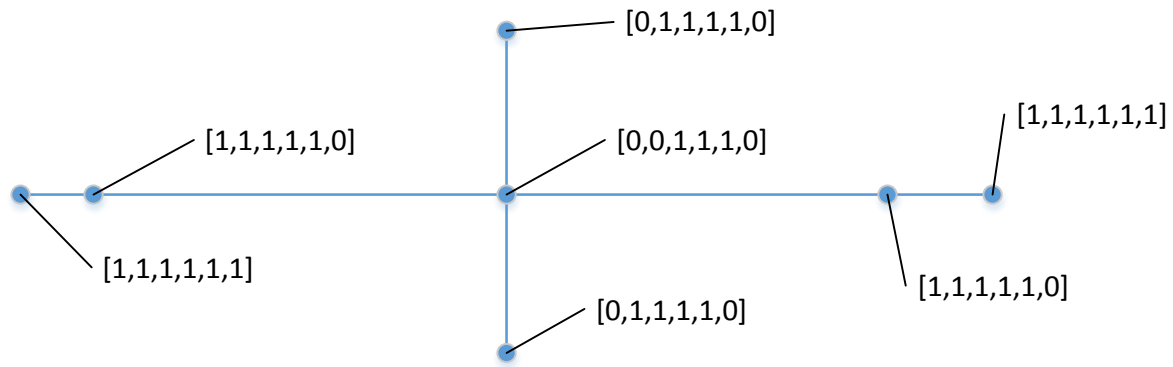

Figure 3.6 DOF in nodes on Barge model. 1=free 0=locked

3.3.5 Mooring line model

The mooring line is modelled as truss-elements in AquaSim. Material data is based on approximate values from a technical report about the offshore semi-sub Eirik Raude[21], various product sheets [22] and from the commission report from NMD[8]. Table 3.4-3.5 presents the parameters given for the anchor line and work wire respectively.

Table 3.4 parameters for anchor line

Diameter	Material	Weight in air	Weight in water	Total length	No. elements
84 mm	Steel	150 kg/m	146.7 kg/m	3500 m	600

Table 3.5 parameters for work wire

Diameter	Material	Weight in air	Weight in water	Total length	No. elements
48 mm	Steel	25kg/m	23 kg/m	340 m	112

Offshore installations are often moored with a combination of chain and wire to reduce weight of the total configuration. The chain can also consist of several different elements and connections. AquaSim allows this configuration to be as realistic as possible as it is just a matter of material input. The configuration presented in the tables above is a simplified one.

The loads on the mooring line is calculated by Morison load definition.

3.4 Modelling in ShipX

The barge is modelled in ShipX by defining simple stations and contour lines [16]to create the overall shape of the hull. The cross-sections are defined in a coordinate-system with x-direction

being positive forward. When sections and contours are defined the hull geometry is presented as shown in Figure 3.7. Due to the simple shape of the barge, only 5 sections is made.

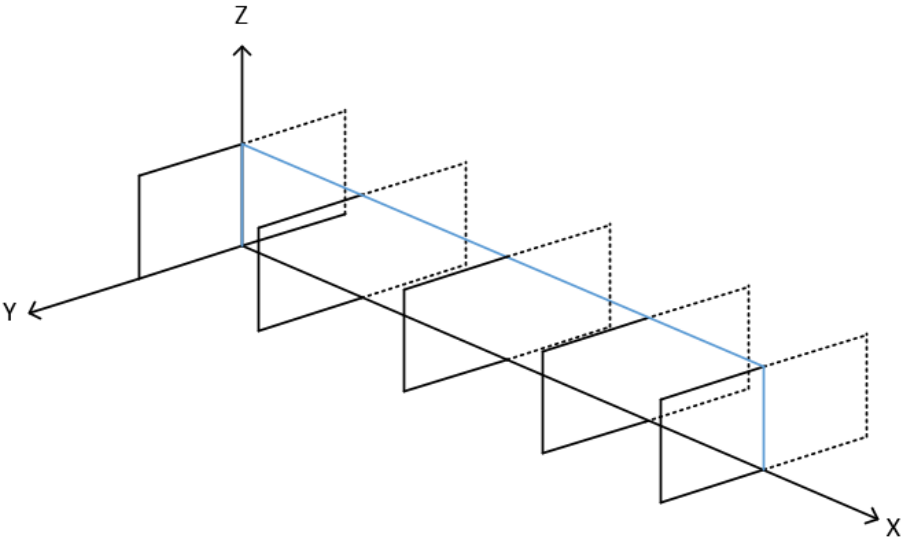

Figure 3.7 Drawing of hull geometry as presented in ShipX

The load condition is defined where draught and length and breadth of waterline is set according to what is given AquaSim. A Vessel Response Calculation is then defined where the vessel description and condition info is set. In the vessel description, metacentric heights, mass, VCG, LCG and radii of gyration is defined to match the data given in AquaSim. The hydrodynamic loads are calculated by using linear strip theory.

4 Case studies

A set of case studies is performed to analyse the barge and mooring line. In this chapter they are presented. They are defined to expose the influence of the mooring line on the barges response in different conditions and loads.

4.1 Case study descriptions

Case study 1 purpose

The purpose of this case study is to get an overview of the vessel response in the initial phase of receiving the mooring line.

Case study 2 purpose

The purpose of this study is to investigate and evaluate the effects of having the approximately full length of the mooring chain trailing from the stern

Case study 3 purpose

With the same position as in case 2, the purpose of this study is to investigate and evaluate the vessel response after the anchor is dropped from the stern hanging from the working line and anchor chain.

For case 1-3 the mooring line is centred. A visual presentation of these cases can be seen in Figure 4.1.

Case study 4 purpose

The purpose of this study is to investigate how the behaviour of the vessel changes when the mooring line is acting outside the centreline and with a varying angle. This case consists of the two conditions presented in Figure 4.2

4.2 Waves and current

A set of waves with defined wave periods, amplitude, heading and current is set in the program for each case study. For time saving and expected relevancy based on the plots in Figure 5.1, only wave periods(T) from 6-9 seconds are considered. For the cases where current is included this is set to 1m/s.

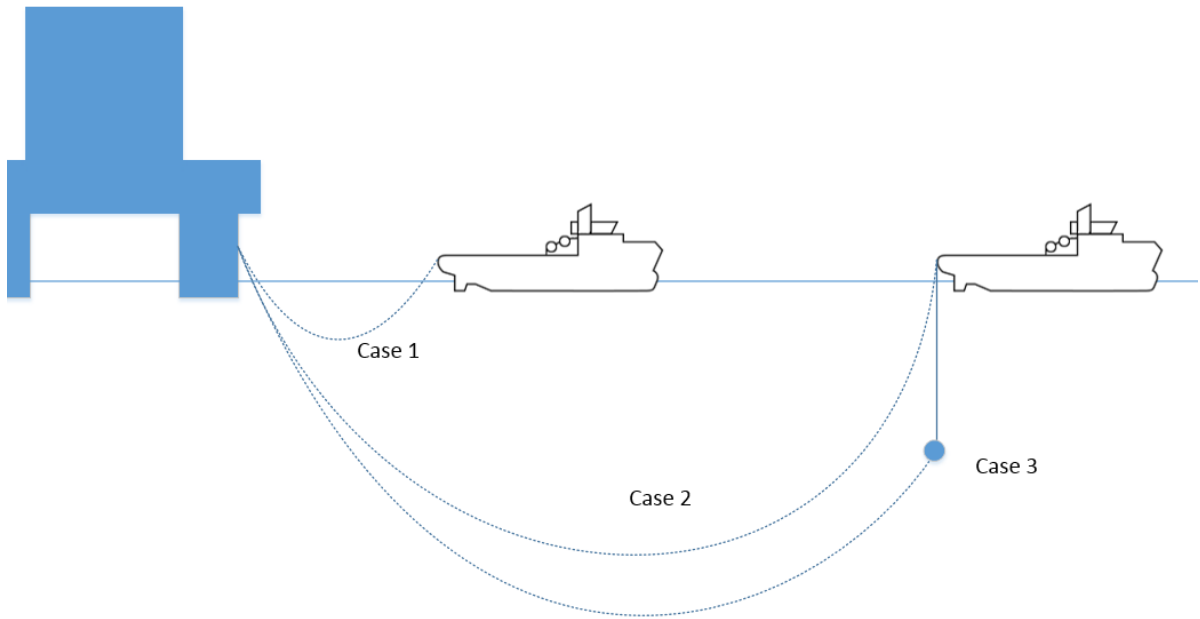

Figure 4.1 Simple study cases of AH operation involving OI and AHV

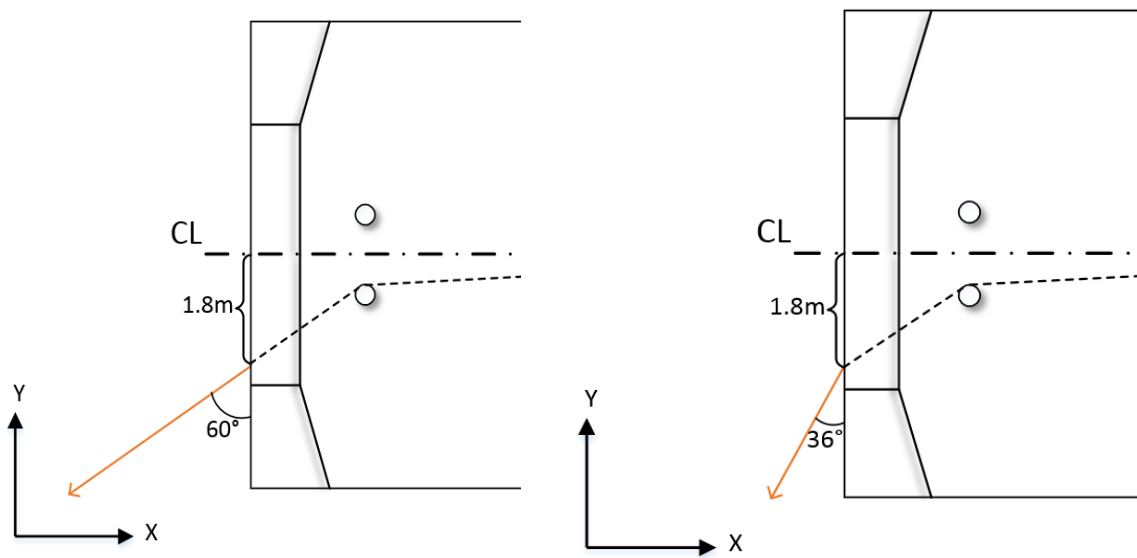

Figure 4.2 Loading conditions for study case 4. Mooring line set at 60 and 36 degrees' angle of attack

5 Simulation and results

This chapter presents the results from the time domain simulations done. From here the study cases will be referred to as Case #1, Case #2 and Case #3 with Case #0 being the barge without mooring line and deck load. In the results chapter only the most necessary plots will be shown as other results are enclosed in the appendix.

The simulations are performed with waves approaching from different directions, in this case 0 and 90 degrees known as head- and beam sea respectively. Depending on the direction of the waves different motions will be more or less occurring. In this project only the most critical motions will be considered and Table 5.1 shows when each of them are considered and the units:

Table 5.1 Wave headings and acting motions

Term	Direction [deg]	Heave[m]	Roll[deg]	Pitch [deg]
Head Sea	0	X		X
Beam Sea	90	X	X	(X) ⁵

The mooring line force is found as “Axial force” in AquaSim and is presented as such in the plots.

5.1 Verification of movements

To verify the dynamic movements of the model and make sure that the values can be taken directly from the analysis the analysis is done both in AquaSim and ShipX for comparison. ShipX is a renowned program for calculating ship response and similar motions between the programs will confirm the legitimacy of the results in AquaSim. This is done by running a “vessel response” in ShipX for the barge model and a simulation in AquaSim. The values in AquaSim are found from reading the maximum, stabilized values for rotation and displacement for the given wave headings and periods with the measurements done from the CoG. In ShipX, these values are plotted automatically as a function of wave period.

Comments on result

Figure 5.1 presents the RAO data from AquaSim and ShipX. The graphs show good correspondence between the programs except for roll. The roll motion found from AquaSim is

⁵ Pitch motion will be considered when the barge is affected by the mooring line

peaking at about 6.5 seconds as predicted in the barge model chapter. In the same section it is also mentioned that this is a very simple estimation of the natural roll period without the inclusion of proper viscous effects which are included in the ShipX calculations.

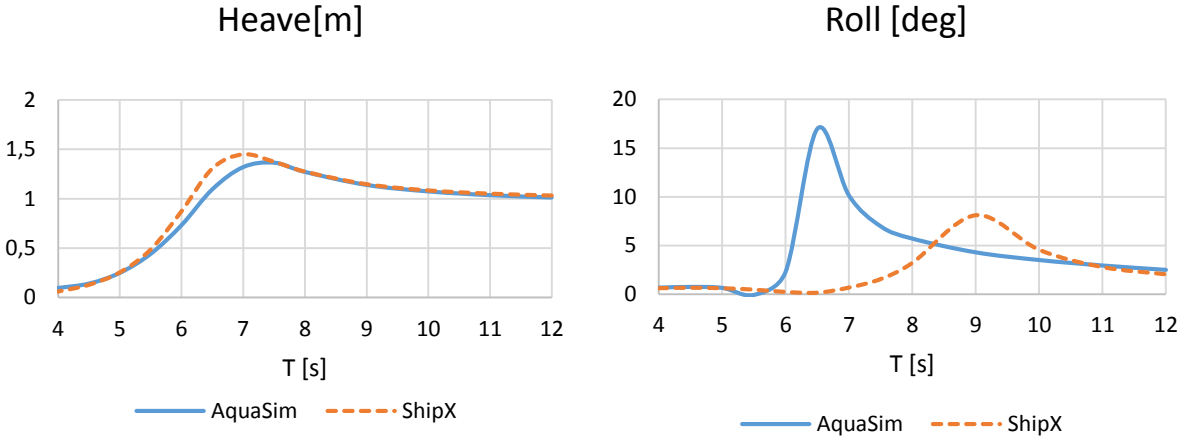

(a) Heave and Roll motion in beam sea

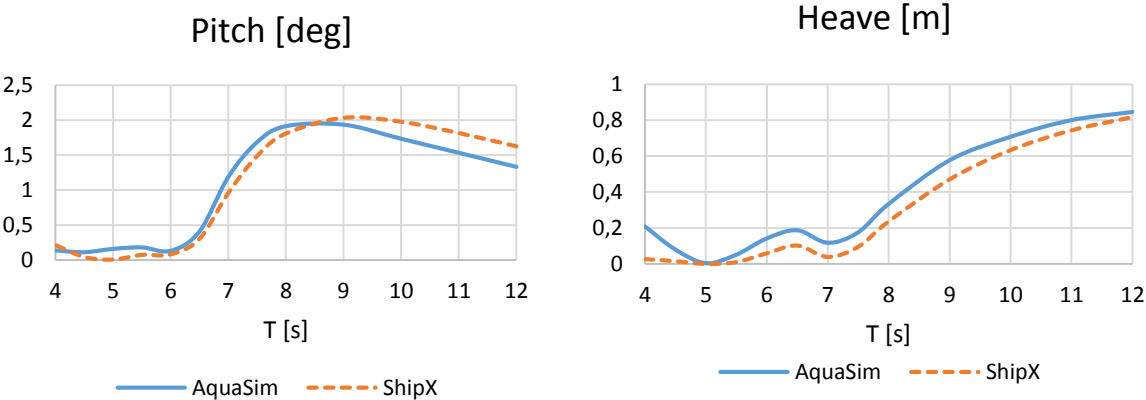

(b) Pitch and Heave motion in head sea

Figure 5.1 Heave, roll and pitch comparison

5.2 Study Case 1 – AHV close to OI

Simulation setup

Head- and beam waves are considered with no current. The mooring line is attached and centred at the stern. The vessel is placed 340m from the OI with the total length of the mooring line at 525m with its lowest point at 200m, leaving the stern with an angle of 40 degrees. The anchor is considered resting the stern.

Comments on results

Some of the results from the simulation are presented in Figures 5.2-5.4. The barge is considered at the shortest distance from the imagined rig and therefore the mooring line is at its shortest length. This situation is reflected in the figures as there are no significant changes in the vessel motions other than what is expected for roll motion around $T=6.5s$. Figure 5.2(a) shows that the addition of the mooring line induce a small static angle in regard of pitch motion in head sea. In this case that angle is measured to be -0.2 degrees, meaning that the vessel is operating with a slight negative trim. The largest pitch motion in head sea is found at $T=9s$ seconds as indicated in Figure 5.1 (b).

Figure 5.2(b) and (c) shows the roll motion for the barge in beam sea. The graph indicates that the addition of the mooring line has a reduction effect on the roll motion at $T=6.5s$ despite that the mooring line is acting in the centre line of the barge. This effect is most notably at $T=6.5s$ which is close to the natural roll period of the barge which can give bigger changes in the amplitude. In Figure 5.3 the time series for pitch motion for beam sea is presented and shows that the motion in beam seas is peaking at around 200 seconds before decreasing compared to pitch motion in head sea which stabilized after 50 seconds.

Figure 5.4 presents the axial force in the mooring line is presented which is the force acting on the stern of the barge. As the figures shows the force at this point is not significantly high, varying from 330 kN at the lowest and 470 kN at the highest, with the biggest variations close to the natural roll period. For $T=4$ the force is close to the median of around 400 kN.

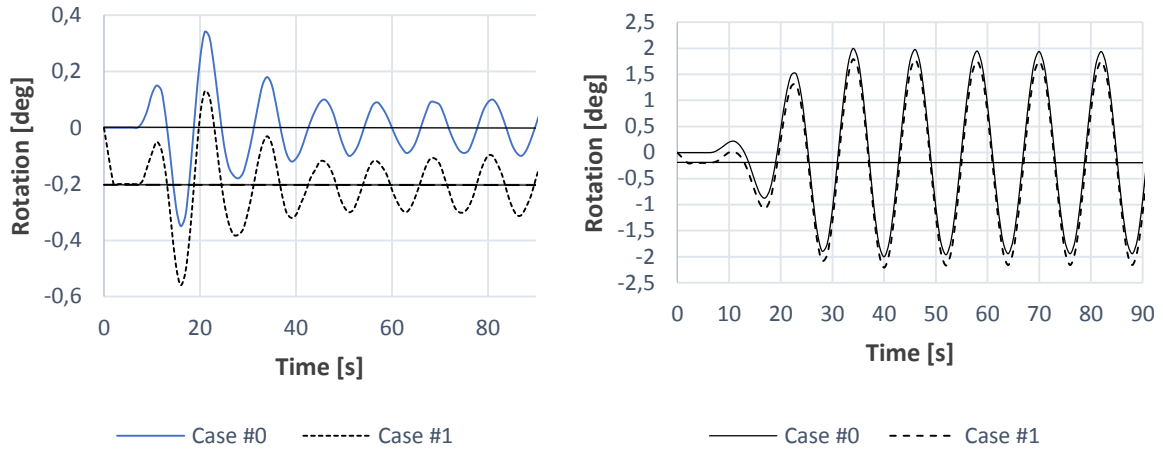

(a) Pitch motion at $T=6.5$ (left) and $T=9$ (right). Head sea

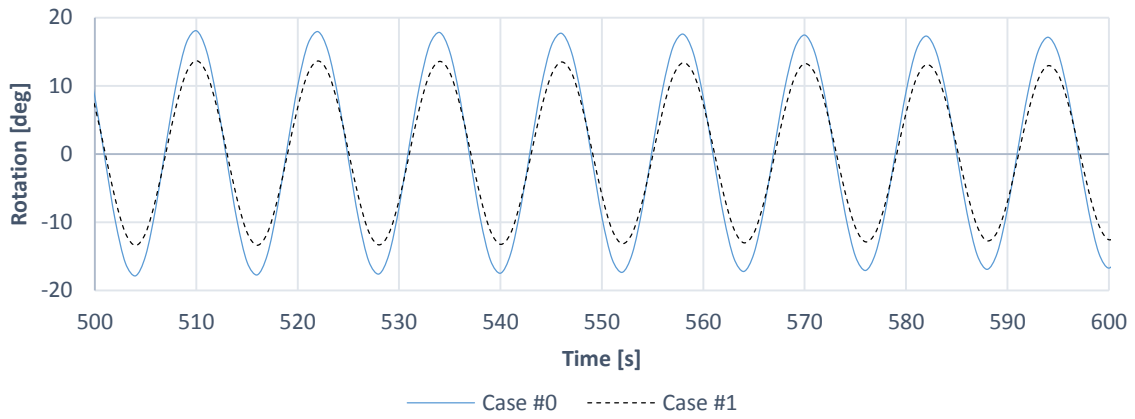

(b) Roll motion for $T=6.5$. Beam sea

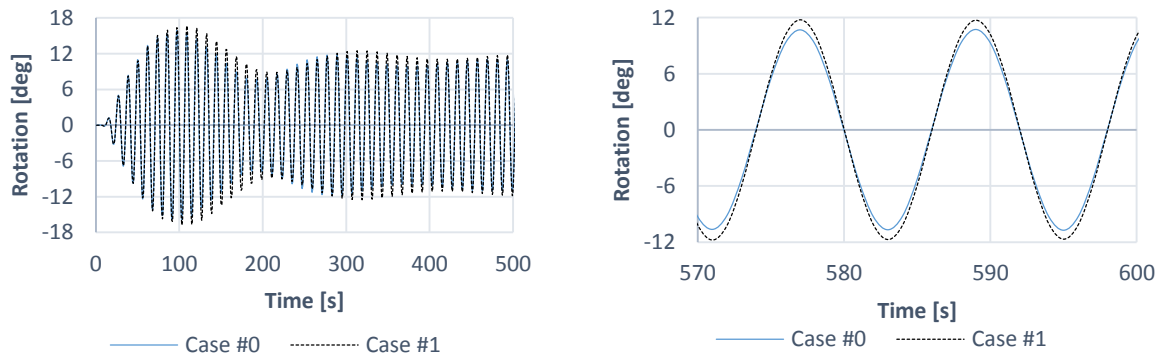

(c) Roll motion for $T=7$ s. Beam sea

Figure 5.2 Case #0 and #1 Comparison of pitch and roll motion at $T=6.5$ s and $T=7$ s.

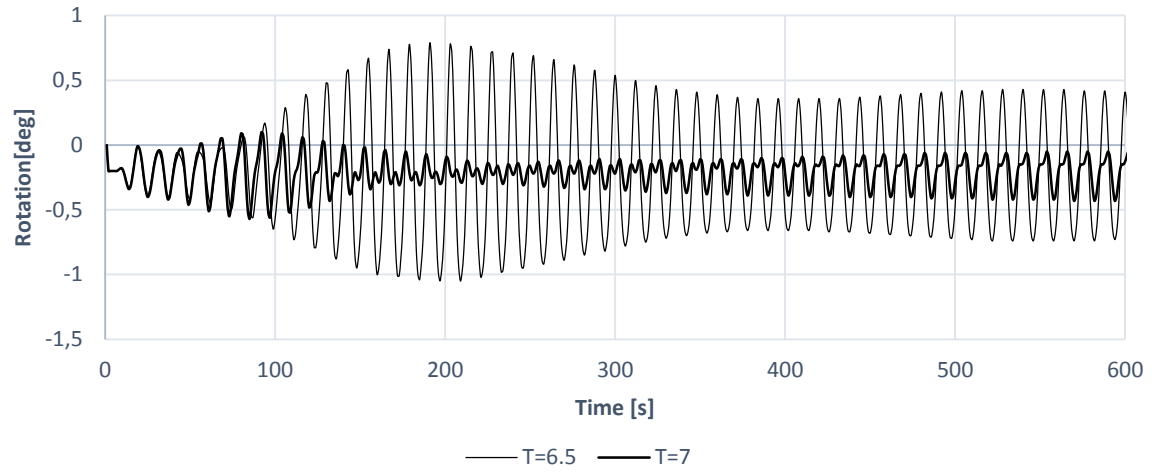

Figure 5.3 Case #1. Pitch motion for T=6.5s and 7s seconds in beam sea.

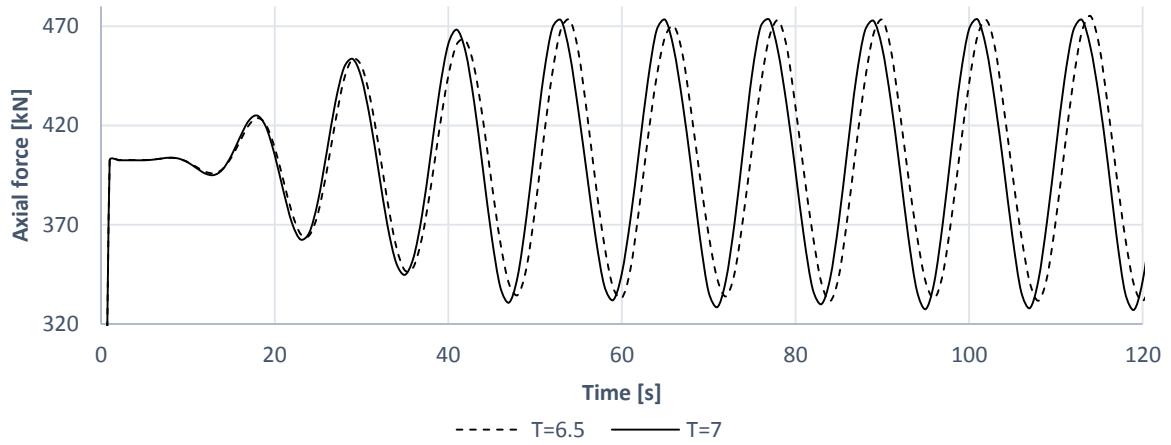

Figure 5.4 Case #1. Axial force in mooring line acting on the stern in beam sea.

5.3 Study Case 2 – At drop point

Simulation setup

In this case study the vessel is placed about 3250m from the IO with the total length of the mooring line at approximately 3500m with the lowest point at 650m depth. In addition to the previously used environmental loads, the effect of current is also considered.

Comments on result

Figure 5.5 presents the heave and pitch motions in head sea. Figure 5.5(a) and shows the pitch motion for a selection of wave periods where the largest amplitude occurs at $T=9s$ with 2 degrees. Overall the amplitudes stabilize early and an increased static angle forces the vessel into a negative initial trim of -1 degree. Figure 5.5(b) shows the highest measured heave motion which is found at $T=9s$ for both case #1 and #2. The graph shows that the mooring line has caused the draught of the barge to increase by 0.12m at midship.

Figure 5.6 presents the roll-, pitch-motion and mooring line force in beam sea. Figure 5.6(a) shows the roll motion measured at $T=6.5s$ and $7s$. The results show that the increased length of the mooring line has increased roll motion and moved the peak from 6.5 seconds to 7 seconds. The roll motion for 6.5 seconds is now decreased by almost a third compared to Figure 5.2(a). Figure 5.6 (b) shows the pitch motion for $T=6.5s$ and $7s$. Judged by the variations in the time series the plots indicates that there is a connection between the pitch motion and roll motion. The added force from the mooring line has increased the static angle and the barge now has an initial trim of -1 degree, compared to -0.2 in Case #1.

Figure 5.6(c) Presents the mooring line force at $T=6.5s$ and $7s$. As with the roll and pitch motion, the peak of the force just before 200 seconds. The amplitudes are then varying in a pulsating pattern. Figure 5.7 presents a comparison of the roll-, pitch-motion and mooring line force for wave amplitudes 1m and 2m. Figure 5.7(a) presents the roll motion at $T=6.5s$ and shows that the roll motion for 2m wave amplitude is much larger and has some larger variations in the beginning but is identical with 1m wave amplitude from 300 seconds and further. Figure 5.7(b) presents the pitch motion at $T=6.5s$ with varying wave amplitudes and shows that increasing the wave amplitude from 1m to 2m causes bigger variation in the pitch motion. The average pitch value also seems to shift over time. Figure 5.7(c) presents the mooring line force which has now also increased.

Figure 5.8 presents the roll motion and mooring line forces influenced by varying wave amplitude and current. Figure 5.8(a) shows that the addition of current has reduced the overall roll motion for both amplitudes and periods. For $T=7s$ with 2m wave amplitude the average value increases rapidly and may indicate that the model is becoming too unstable.

Figure 5.8(b) shows the mooring line force for $T=6.5s$ influenced by current and varying wave amplitude. As with the roll and pitch motions it has been reduced.

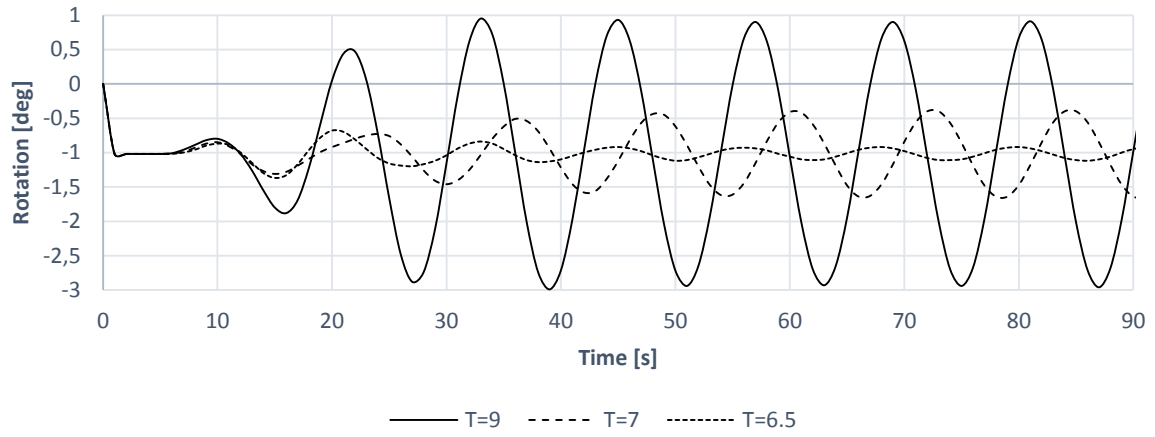

(a) Case #2. Comparison of Pitch motions for head sea

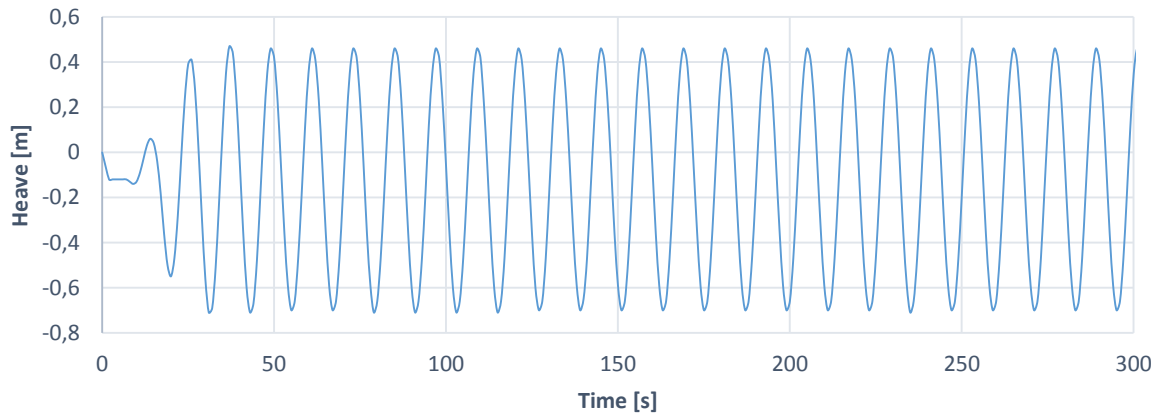

(b) Case #2. Heave motion for T=9. Head sea

Figure 5.5 Pitch and heave motion in head sea

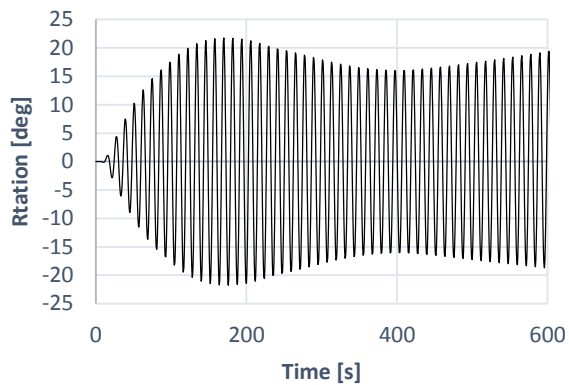
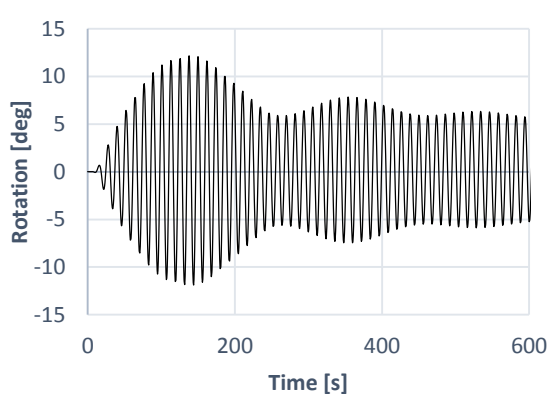

(a) Case #2. Comparison of roll motion at T=6.5s(left) and 7s(right). Beam sea

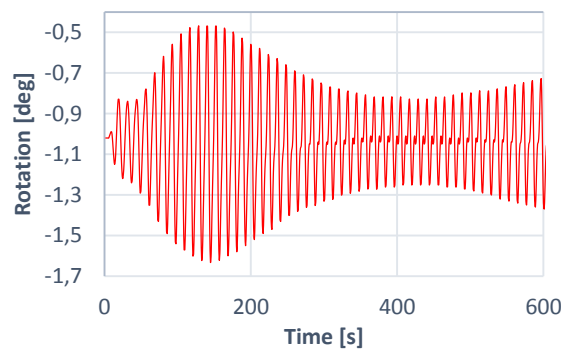
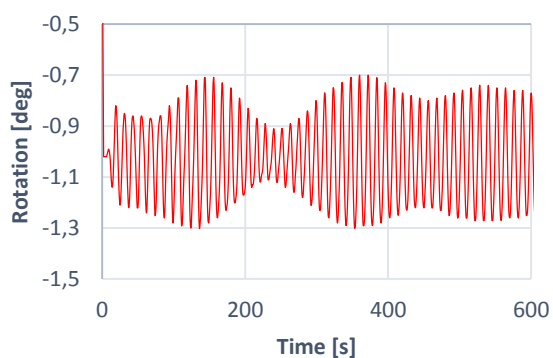

(b) Case #2. Comparison of pitch motion at T=6.5s(left) and 7s(right). Beam sea

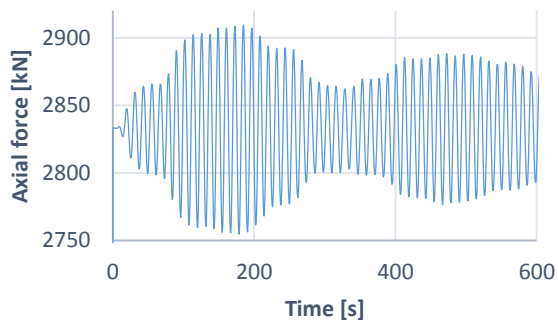
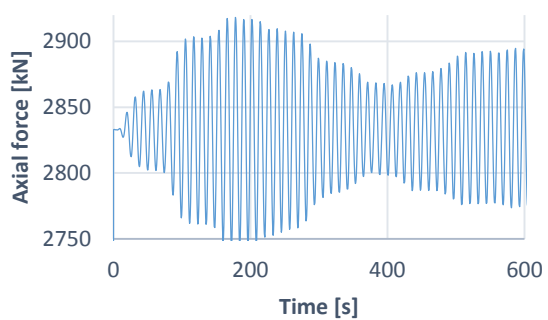

(c) Case #2. Comparance of force in mooring line at T=6.5s(left) and 7s(right). Beam sea

Figure 5.6 Case #2. Roll-, pitch-motion and mooring line force at T=6.5s and 7s. Beam sea

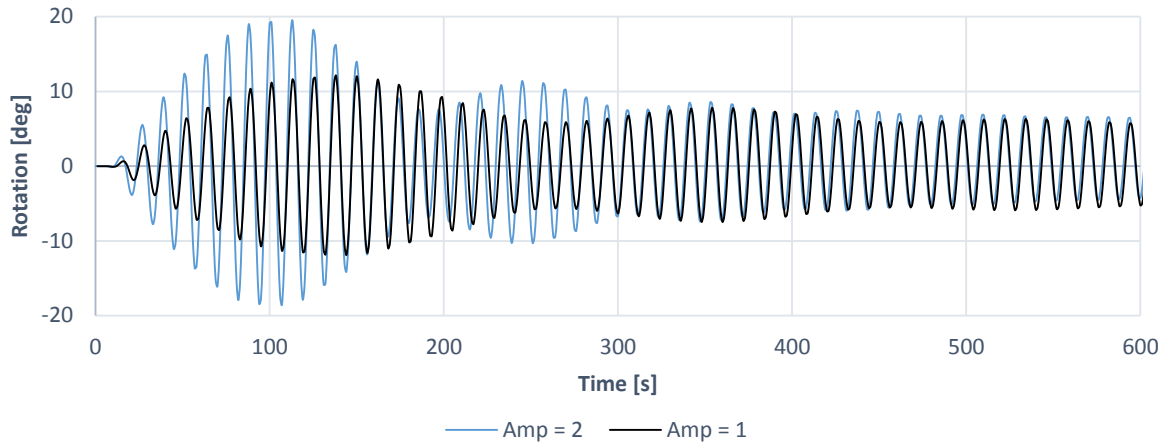

(a) Case #2. Roll motion for $T=6.5s$, with amplitude 1m and 2m. Beam sea

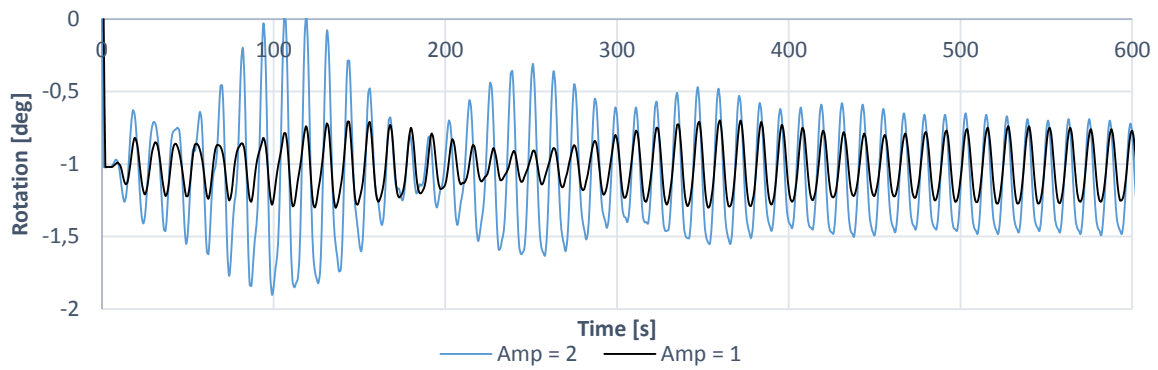

(b) Case #2. Pitch motion for $T=6.5s$ with amplitude 1m and 2m. Beam sea

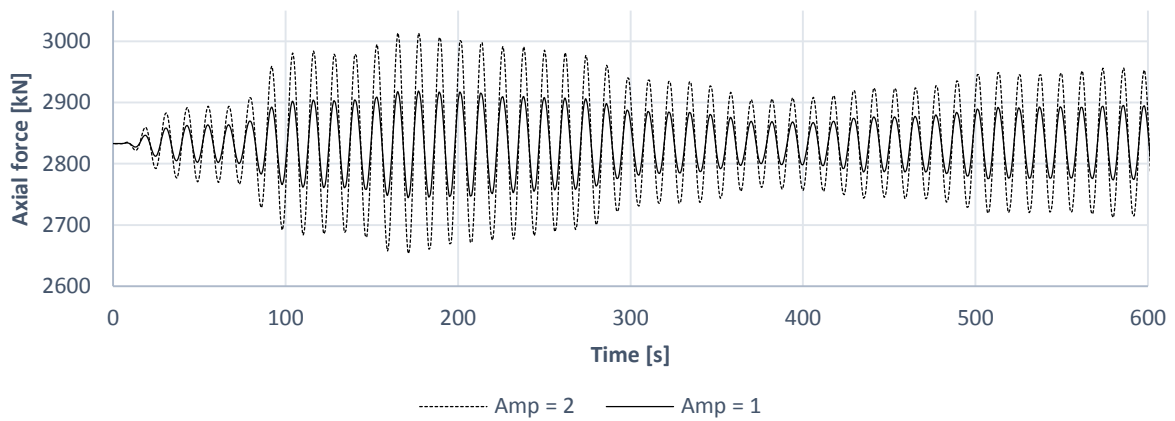

(c) Case #2. Mooring line force at $T=6.5s$ with amplitude 1m and 2m. Beam sea

Figure 5.7 Roll motion with amplitude 1 and 2. Case #2

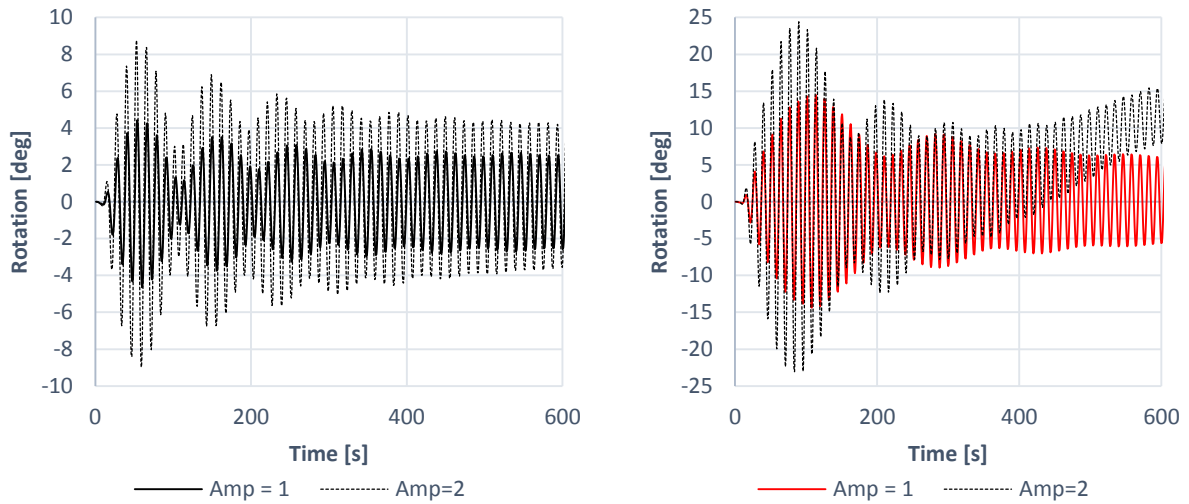

(a) Case #2. Roll motion for $T=6.5s$ (left) and $7s$ (right) for amplitude 1m and 2m with current = 1m/s

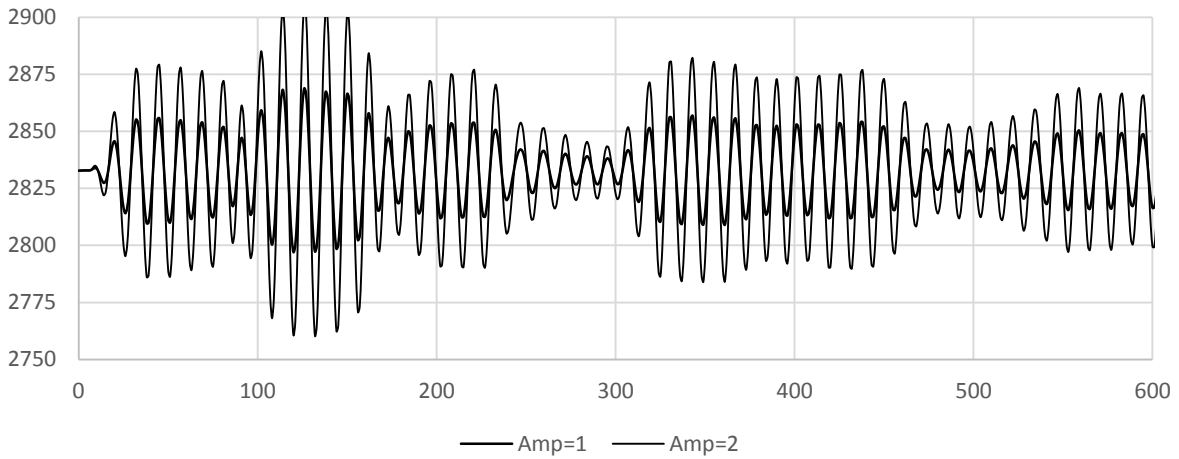

(b) Case #2. Comparison between mooring line force at $T= 6.5s$ with current = 1 m/s. Amplitude 1m and 2m

Figure 5.8 Roll motion and mooring line force with varying amplitudes and with current.

5.4 Study Case 3 – Anchor in water

Simulation setup

Vessel positioned as in Case #2 but with the anchor now hanging from the stern at about 340m depth. Previous environmental loads apply.

Comments on results

Figure 5.9 presents the pitch and heave motion in head sea. Figure 5.9(a) presents the pitch motion for $T=9s$ and indicates that moving the anchor from the stern roller into the water does not affect the pitch significantly compared to Case #2. Figure 5.9(b) presents highest measured heave motion which is measured at $T=9s$. There is no significant difference in amplitude compared to Case #2.

Figure 5.10 presents roll-, pitch-motion and mooring line force at $T=6.5s$ and $7s$. Overall the roll- and pitch-motions are similar to what seen in case #2 but with some reduced values. Figure 5.10(c) presents the mooring line at $T=6.5s$ and $7s$. The figure is showing that the average mooring line forces for $T=6.5s$ and $7s$ have decreased from 2833 kN to 2653 kN and the time series are more unstable compared to case #2.

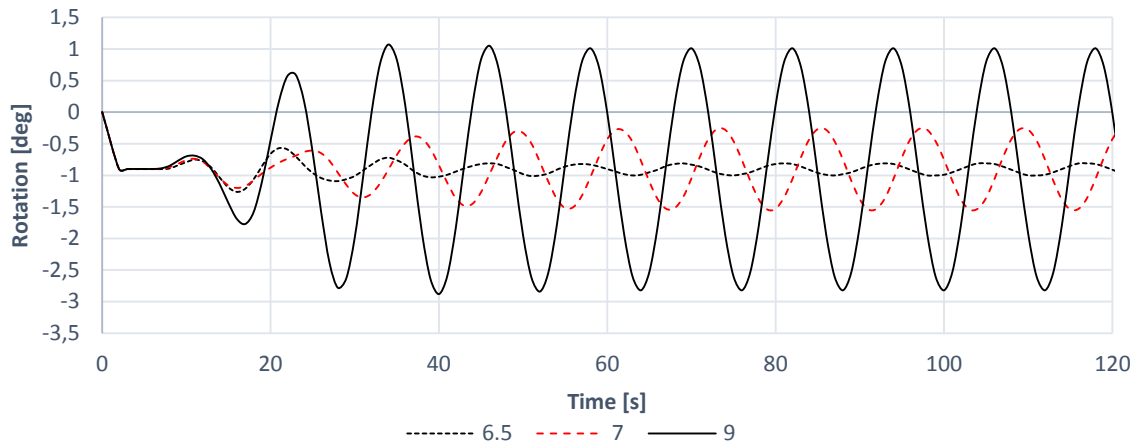

(a) Pitch motion for $T=6.5s$, $7s$ and $9s$. Head sea

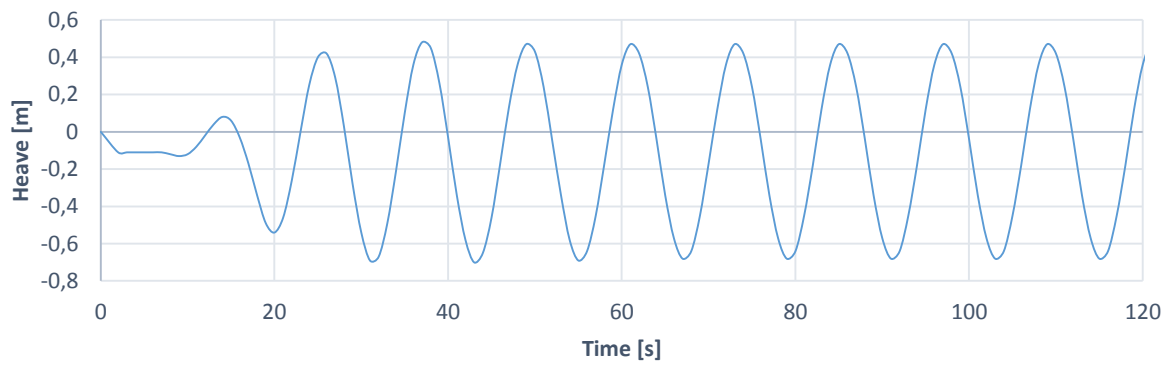

(b) Heave motion for $T=9s$. Head sea

Figure 5.9 Case #3. Pitch and Heave motions in head sea

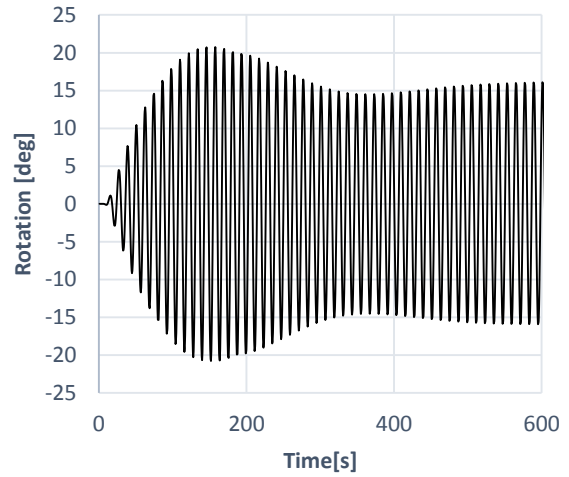
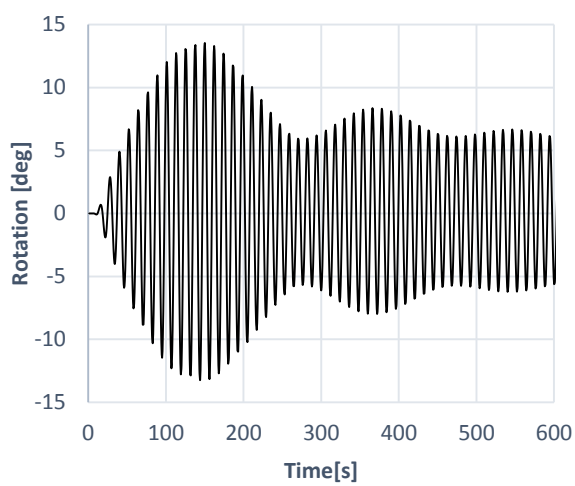

(a) Roll motion in beam sea for $T=6.5s$ (left) and $T=7s$ (right)

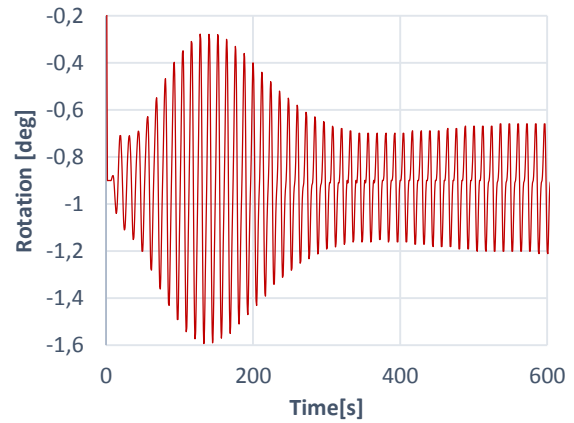
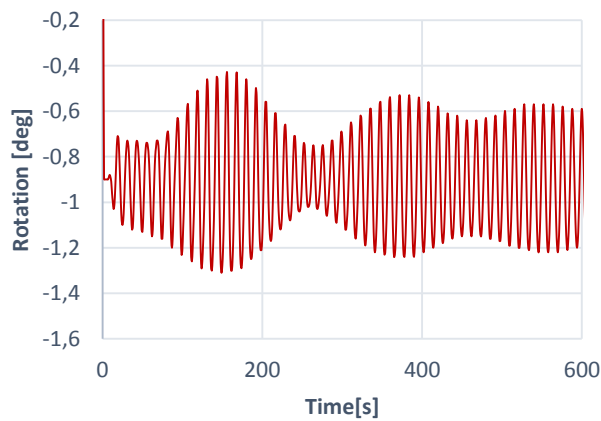

(b) Pitch motion in beam sea for $T=6.5s$ (left) and $T=7s$ (right)

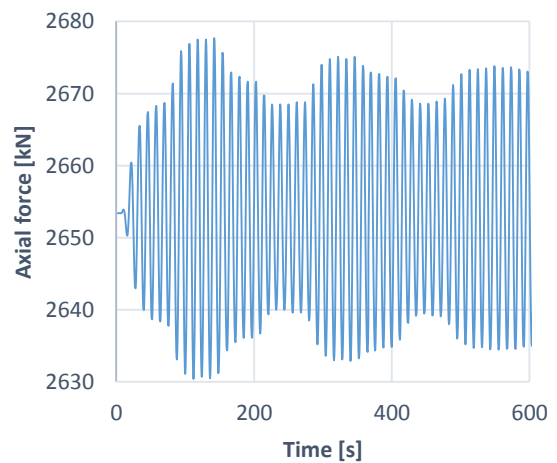
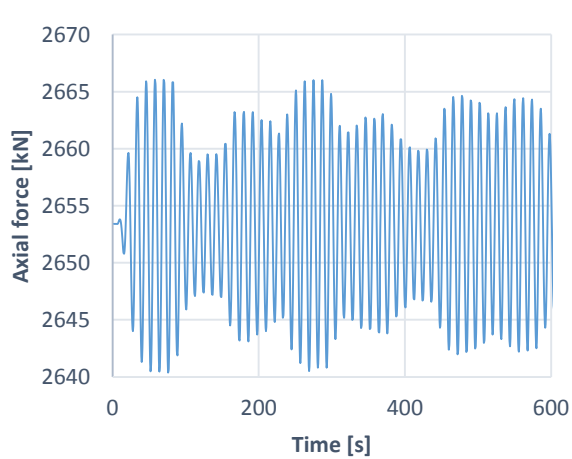

(c) Axial forces for $T=6.5s$ (left) and $T=7s$ (right)

Figure 5.10 Case #3. Roll-, pitch-motion and mooring line force in beam sea

5.5 Case study 4 – Angled line with offset from centre

Simulation setup

This case is based on case 2 with the only difference being the change in direction of the mooring line. Two conditions are simulated with the mooring line pulling the vessel from 60° and 36° (relative to the YZ-plane).

Comments on result

Figure 5.11 presents the roll- and pitch motion with variation in mooring line angle. Figure 5.11(a)(b) shows the roll motion for $T=9s$ and $7s$ with 60° and 36° angle on the mooring line. The graph shows that there is a minor difference in the static angle from 60° and 36° and that the mooring line in 60° angle is inducing higher amplitudes compared to 36° for both periods.

5.11(c) Shows the pitch motion for $T=7s$ with variation in mooring line angle. There is not much difference between the two variations but most noticeably is that the time series are more unstable and the amplitudes are varying irregularly. As the trendlines are indicating, the average pitch motion is increasing which means that the barge is unstable, at least for the simulated period.

Figure 5.12 presents a summary of roll motion measured in the study cases. It shows how the peak period of the roll motion is moving from $T=6.5s$ to $7s$ as a result of the mooring line configuration changing. It is clear that the increased length of the mooring line and the change in position has a negative effect on the roll motion.

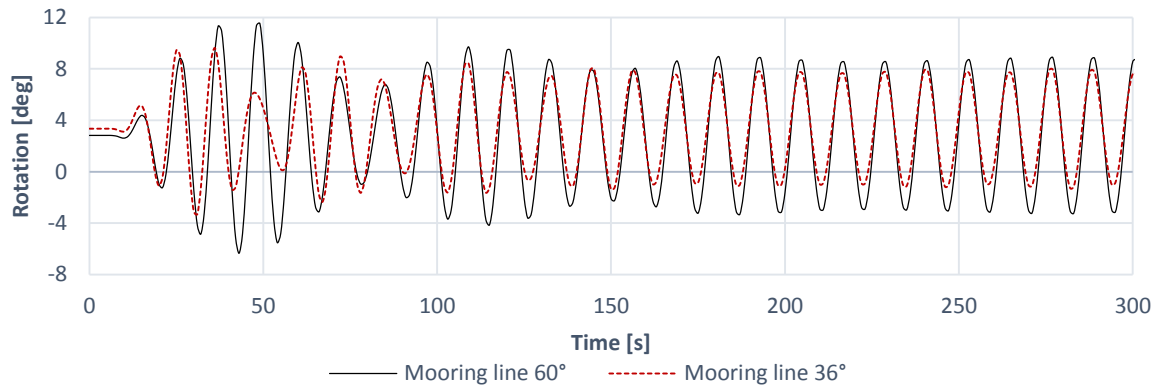

(a) Roll motion for $T=9s$. Beam sea

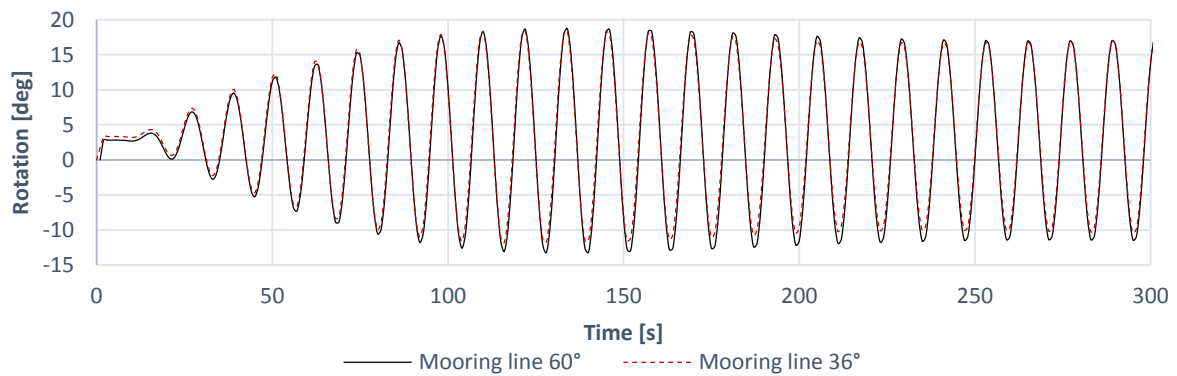

(b) Roll motion for $T=7s$. Beam sea

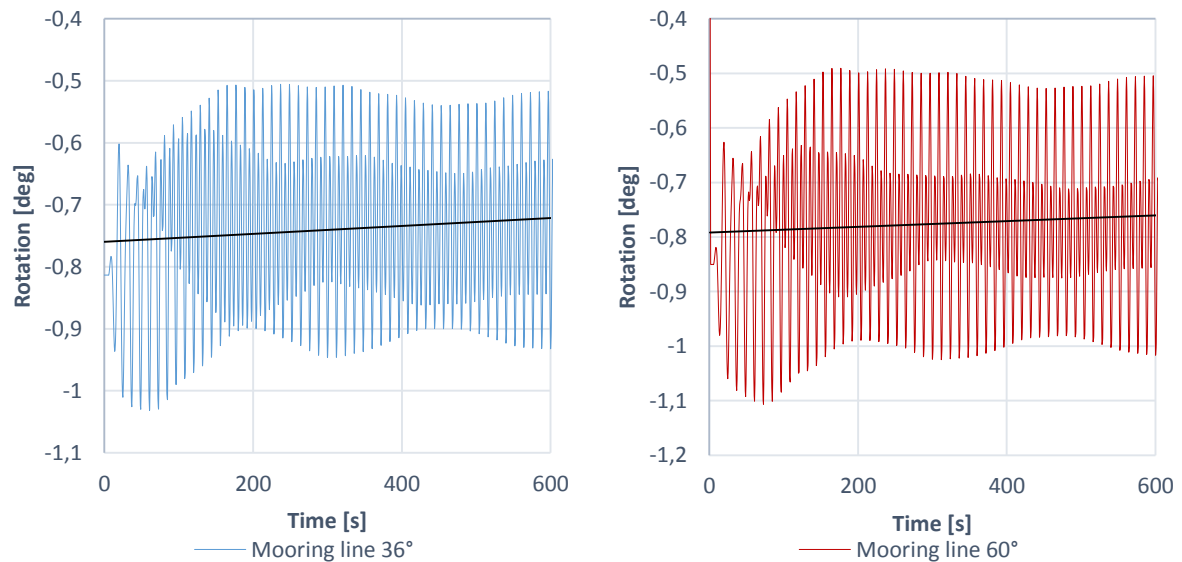

(c) Pitch motion for $T=7s$. Beam sea

Figure 5.11 Case #4. Roll- and pitch-motion with varying angle on mooring line and 1.8m offset from barge centre line.

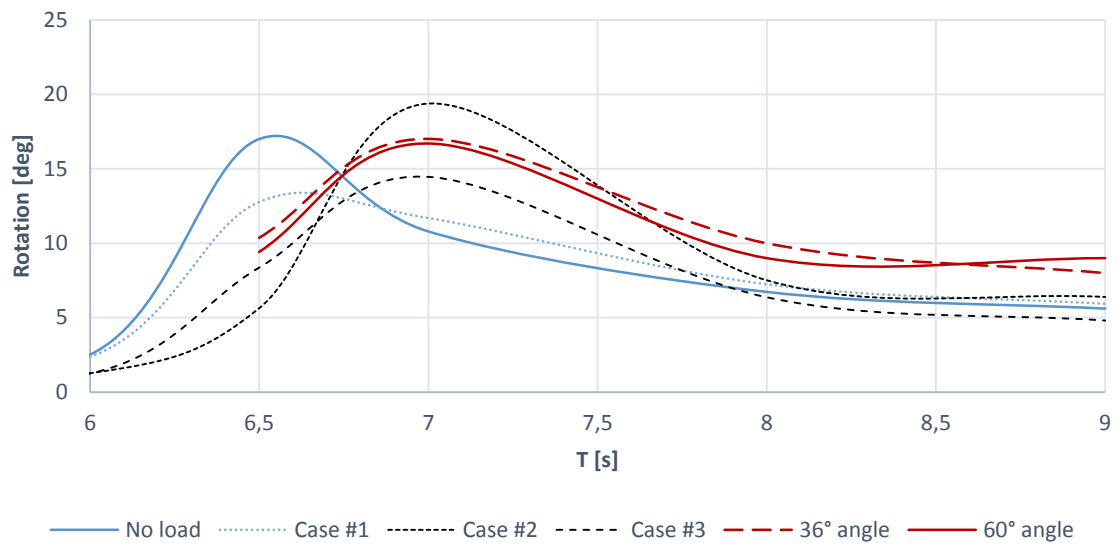

Figure 5.12 Comparison of roll motion for all study cases based on wave period.

6 Discussion

6.1 Software

The AquaSim package consists of several modules as mentioned which aims to aid through the whole analysis process and proves to be a versatile software for mooring analyses. For this project however, there were some complications when setting up the analysis. It seems like the main strength of the program is mooring analysis with non-free floating constructions moored in several directions compared to a free floating vessel with a mooring line attached to it.

6.2 Barge simplifications

The initial plan was to use a simple barge model while getting to know the software and later use a more realistic model of an AHV for the analysis and motion verifications however, it proved difficult to get a realistic ship model implemented into the software as it would require several elements each with individual input. An attempt was done to make more complex hull but due to the amount of input needed and general uncertainty about the functionality of the model at that time the idea was abandoned. It was decided that the barge would be the test vessel for the simulation and it was dimensioned to resemble a larger offshore vessel.

The modelling of the barge was done according to a user manual provided by Aquastructures which explained step by step how a barge should be modelled. The barge in the manual where about half the size of the one used in the project. There were some issues regarding the moment of inertia as the analysis would not run with the given input. By recommendation from Aquastructures the default values from the manual were used.

In the early stages of the simulation there were some problems with the analysis as it was unable to converge for certain cases. When investigating the case in the AquaView module it showed that the barge model started to lose its stiffness and split up after a certain amount of simulation time. This could be due to the modelling technique used not being meant for barges at this size and that the input given does not correspond to its physical size.

6.3 Constraints

Due to the issues regarding convergence and the analysis not starting the model was given extra constraints. Initially it was just locked in G for x- and y-translation to avoid it drifting away.

Later in the process the mentioned problems regarding the stiffness of the model and elements splitting up made it necessary to lock the end nodes of the 2D-hydrodynamic element. After some trials and errors, the nodes were locked in x-translation and z-rotation as it was considered the option with the least negative impact on the barge behaviour. Two extra nodes were placed fore and aft to act as bow and side thrusters with the intension to measure the eventual thrust force needed to hold the barge in position. Due to no immediate solution to this at the given time the idea was abandoned but the nodes were kept locked in x-and y-translation(aft) and y-translation(fore).

6.4 Differences in roll motion

Figure 5.1(b) presents the comparison between measured roll motion in ShipX and AquaSim. For this motion there was a large deviation between the two sets of data as there are two different peaks indicating different natural roll period of the barge models. In chapter 3.2.2 an estimation of the natural roll period was presented which gave a value similar to the one seen in Figure 5.1(b). This formula does not include viscous effects such as added mass and default values were used in the setup. Therefore, it is reason to believe that the input regarding roll damping in the simulation is insufficient. This may explain the high roll motions experienced in the results as well. In [20] there is also a comment about roll damping for barges, stating that:

“In order to make a more physically correct assumption to this in AquaSim one should model barges with eccentric beams longitudinally close to the lower corner of the vessel. These beams should have a drag area corresponding to the effect of the corner of the section or to the actual bilge keel. In this case drag loading will be treated in a more exact manner in AquaSim”

“The Aquastructure Package User Manual”, page 73.

This was not mentioned in the procedure used in this project is therefore not included.

6.5 Results

The main results are already commented before every study case but some reflection is needed. The overall impression is that there are some clear connections between the time series however, this varied a lot between wave periods and not all results were stable and kept increasing as the time simulation time went on.

The model used in the analysis was far from optimal as constraints and simplifications were done to get it to work. There is reason to believe that these measures affected the results. Based on the results and previous comments it is clear that especially the results found for roll motion should be considered invalid when considering periods close to the natural roll period.

In case #1 the barge was subject to the least amount of force as the mooring line was relatively short. Some minor changes in static angles for trim was registered and slight changes in roll amplitude but the variations were the same. In Case #2 the mooring line was at its longest hence the larger forces and thereby larger responses. Figure 5.10 indicate that roll and heave follows the same pattern for each wave period while there were no clear connections with the variation of mooring line forces. The exception may be that it is evident that by increasing the environmental loads, mainly increasing wave amplitude and adding current induced multiple variations in all responses(Figure 5.8) which seemed to follow the same pattern. There were no significant changes in case #3.

In case #4 the mooring line was placed outside the centre line of the barge, more specifically 1.8m and with the mooring line angle in two different angles. These angles were somewhat randomly chosen. Most interesting here is that the mooring line in an 60° angle is inducing both higher roll- and pitch-motion compared to 36° and that the roll motion is reduced for both angles. One explanation of this can be that the forces from the mooring line at the smaller angle is inducing a yaw-motion rather than roll and pitch compared to the larger angle. and that the offset of 1.8m is the main factor. Combined with the constraints that locks the barges yaw motion, the change in angle of the mooring line may limit the barges roll motion.

When comparing the cases for roll motion, it is clear that the length and position of the mooring line has a negative effect on the roll motion.

7 Conclusion and future work

7.1 Conclusion

A final model resembling a barge with a mooring chain and working line have been modelled and simulated in AquaSim for some specific load cases. From these, data describing the motions of the barge and force acting on it from the mooring line were extracted.

The main field of use for AquaSim is mooring analysis of different kinds which the interface of the program reflected. This made it rather easy to model a relatively complex mooring setup with different types of chain and wires, given the right input. Still, the models used in this project can be considered somewhat simplified as not all parameters were clearly defined and thus given default values.

The barge model has some critical limitations. One of them is the mechanical properties which required input of different moments of inertia however, when calculating them for the barge with respect to its size the simulation often encountered convergence issues. As a solution to this, default values were used, based on recommendations from some of the developers of the program. As these values represented a much smaller barge, the mechanical properties used are not correct. This became evident when the model was compared with an identical model in ShipX, as the RAO's were more or less identical except for the roll motion. The deviation increased for higher roll amplitudes and should therefore be considered invalid for certain wave periods.

The modelling technique used to create the barge can be questioned as some of the convergence issues that were encountered came as a result of the models tendency to split after a certain amount of simulation time. From the look of it, it seemed like the model split at points where the elements were divided by nodes, basically dividing the main element and hydrodynamic element into two rectangles each. Similar issues were identified when measuring pitch motions as there were signs of the barge not being rigid enough longitudinally, causing and inconsistent rotational movement about y-axis.

Study cases were set up and analysed to investigate the mooring lines effect of the barge response under varying environmental loads. The simulations show that the barge is subject to

great amount of force from the mooring line, with varying differences of up to 200 kN found for specific conditions. This is mostly due to the increased length of the mooring line and the change in angle and position of the line. The results also indicate that worse sea conditions through increased wave height and current increase the forces acting on the barge and making the response more varying.

7.2 Future work

- A more realistic ship model should be implemented or the model technique for the barge should be altered as the size seems to cause some problems. Eventual changes could include the part quoted in the discussion section regarding roll damping. The input regarding this should be more adjusted to the given analysis.
- Without having too much knowledge about the software, the analysis may be more suitable together with the stability software AquaStab, especially when it comes to analysing the stability regarding rules and criteria.
- A more sophisticated mooring line configuration should be made and cases involving seabed interaction might be interesting to investigate as the software is capable of this.
- Analysis involving waves approaching from 45 degrees should be investigated as it is highly relevant and induces coupled motions.

REFERENCES

- [1] NOU, Norges offentlige utredninger, “*Bourbon Dolphins forlis den 12. april 2007.*” (2008)
- [2] M. Hancox and H. Clarkson, “*Anchor Handling*” (2011).
- [3] www.skipsmedia.no/island-vanguard (C.Tussøy)(01.06.2016)
- [4] www.rolls-royce.com (20.05.16)
- [5] J. Journée and W. Massie, “*Offshore hydromechanics*” (2000).
- [6] K. Koskinen “*Numerical simulation of ship motion due to waves and manoeuvring*”.(2012)
- [7] A. Biran and R. L. Pulido, “*Ship hydrostatics and stability.*” (2013).
- [8] MARINTEK AS, “*ShipX Vessel Responses (VERES) User’s Manual*” (2015).
- [9] DNV GL “*rules for classification for ships Pt. 3 Ch. 15 Sec. 1,*” (2015)
- [10] Sjøfartsdirektoratet, “*Rapport om tiltak for ankerhånderingsfartøy og flyttbare innretninger.*” (10.02.2009)
- [11] Aquastructures AS, “*AquaEdit user manual*”. (2016)
- [12] Aquastructures AS, “*AquaBase user manual*”. (2016)
- [13] Aquastructures AS, “*AquaTool user manual*”. (2016)
- [14] Aquastructures AS, “*AquaView user manual*”. (2016)
- [15] G. Ritchie, “*Practical introduction to anchor handling and supply vessel operations*” (2007)
- [16] MARINTEK AS, “*ShipX Workbench Getting Started,*” (2004).
- [17] S. Fjelde. ”*Stability and motion response analyses of transport with barge.*” (2008)
- [18] J.A. Berstad, ”*Theoretical formulation of structure and load modelling, Report no.2006-301*”(2006)
- [19] Aquastructures AS, “*Brukermanual AquaSim Fortøyningsanalyse av fórflåter,*” (2016).
- [20] Aquastructures AS, “*The AquaSim Package User Manual*”. (2014)
- [21] Inocean AS, “*Eirik Raude Semi-Submersible Drilling Unit, Calculation of Mooring System.*” (2005)
- [22] J.G. Maritime, “*Anchor manual 2015 the guide to anchoring.*” (2015)

APPENDIX A – Model input

In this appendix is the material data for the elements in the Barge assembly.

Main element:

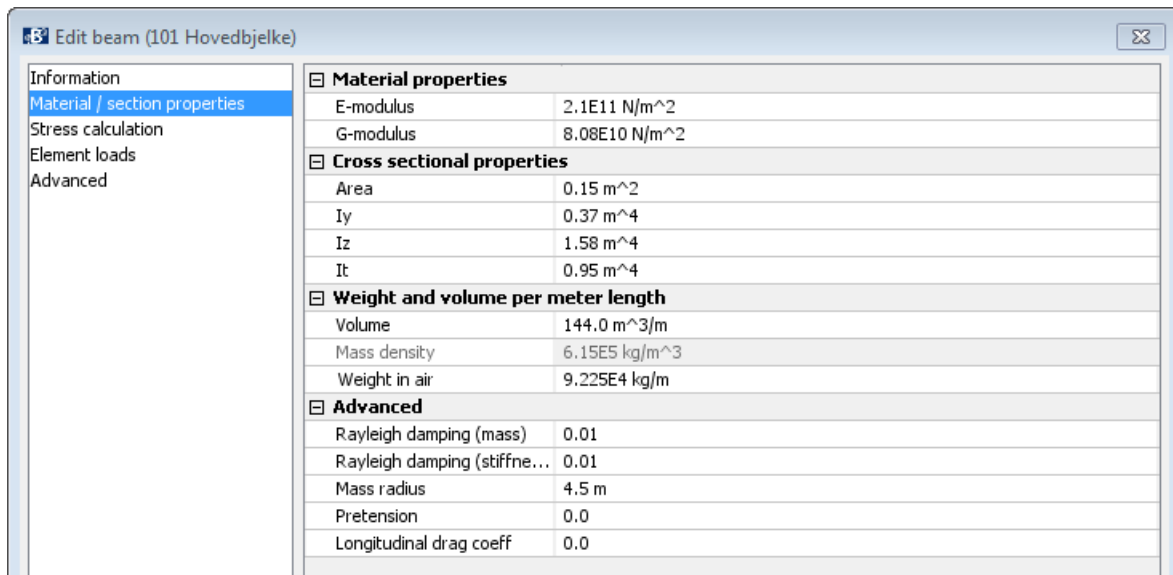

The screenshot shows the 'Edit beam (101 Hovedbjelke)' dialog box with the 'Material / section properties' tab selected. The left sidebar contains 'Information', 'Material / section properties', 'Stress calculation', 'Element loads', and 'Advanced'. The main area displays the following properties:

Material properties	
E-modulus	2.1E11 N/m ²
G-modulus	8.08E10 N/m ²

Cross sectional properties	
Area	0.15 m ²
Iy	0.37 m ⁴
Iz	1.58 m ⁴
It	0.95 m ⁴

Weight and volume per meter length	
Volume	144.0 m ³ /m
Mass density	6.15E5 kg/m ³
Weight in air	9.225E4 kg/m

Advanced	
Rayleigh damping (mass)	0.01
Rayleigh damping (stiffne...)	0.01
Mass radius	4.5 m
Pretension	0.0
Longitudinal drag coeff	0.0

Material/section properties for Main beam

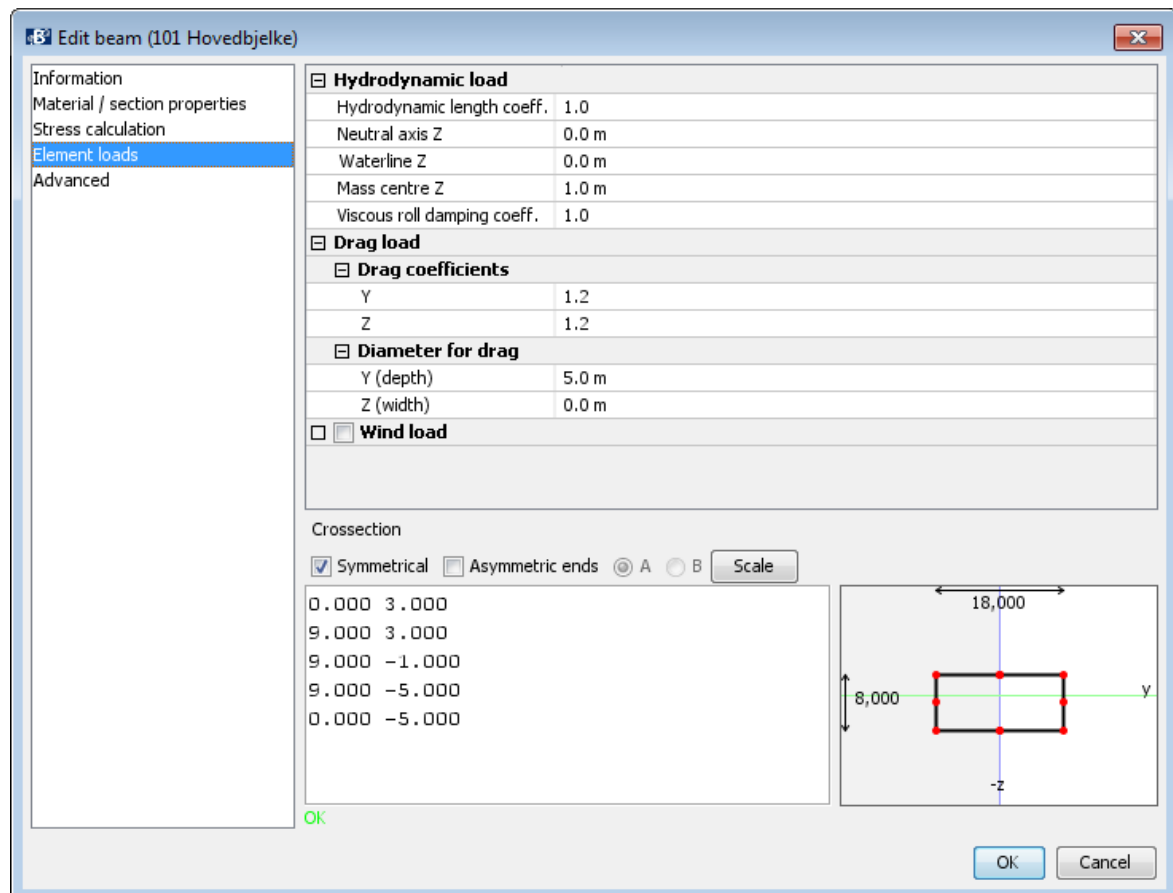

The screenshot shows the 'Edit beam (101 Hovedbjelke)' dialog box with the 'Element loads' tab selected. The left sidebar contains 'Information', 'Material / section properties', 'Stress calculation', 'Element loads', and 'Advanced'. The main area displays the following properties:

Hydrodynamic load	
Hydrodynamic length coeff.	1.0
Neutral axis Z	0.0 m
Waterline Z	0.0 m
Mass centre Z	1.0 m
Viscous roll damping coeff.	1.0

Drag load	
Drag coefficients	
Y	1.2
Z	1.2
Diameter for drag	
Y (depth)	5.0 m
Z (width)	0.0 m

Wind load

Crosssection

Symmetrical Asymmetric ends A B

0.000	3.000
9.000	3.000
9.000	-1.000
9.000	-5.000
0.000	-5.000

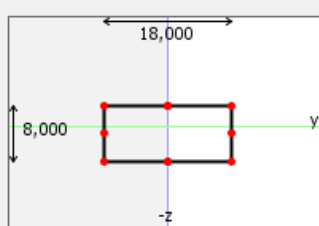

OK

2D hydrodynamic element:

Edit beam (102 Hydro komponent)

Information
Material / section properties
 Stress calculation
 Element loads
 Advanced

Material properties

E-modulus	2.1E11 N/m ²
G-modulus	8.08E10 N/m ²

Cross sectional properties

Area	0.015 m ²
Iy	0.037 m ⁴
Iz	0.0158 m ⁴
It	0.095 m ⁴

Weight and volume per meter length

Volume	0.0 m ³ /m
Mass density	6.66667 kg/m ³
Weight in air	0.1 kg/m

Advanced

Rayleigh damping (mass)	0.01
Rayleigh damping (stiffne...)	0.01
Mass radius	0.0 m
Pretension	0.0
Longitudinal drag coeff	0.0

Edit beam (102 Hydro komponent)

Information
 Material / section properties
 Stress calculation
Element loads
 Advanced

Hydrodynamic load

Hydrodynamic length coeff.	1.0
Neutral axis Z	0.0 m
Waterline Z	0.0 m
Mass centre Z	1.0 m
Viscous roll damping coeff.	1.0

Drag load

Drag coefficients

Y	1.2
Z	1.2

Diameter for drag

Y (depth)	5.0 m
Z (width)	0.0 m

Wind load

Crosssection

Symmetrical Asymmetric ends A B

0.000	3.000
40.000	3.000
40.000	-5.000
0.000	-5.000

OK

Working line

Edit truss: 306 Working line

Information
Windload
Damper
Advanced

Information	
Name	Working line
Description	Applied from: Mooring line South 48 mm
Properties	
E-modulus	2.1E9 N/m ²
Area	1.8096E-3 m ²
<input type="checkbox"/> Volume	1.8096E-3 m ³
Mass density	1.3815E4 kg/m ³
Weight in air	25.0 kg/m
<input type="checkbox"/> Weight in water	23.14516 kg/m
Drag loads	
Diameter Y	0.048 m
Diameter Z	0.048 m
Drag coefficient Y	1.2
Drag coefficient Z	1.2
Added mass coefficient Y	1.0
Added mass coefficient Z	1.0
Default values	
No compression forces	<input type="checkbox"/>
Pretension	0.0
Breaking load	0.0 N
Material coefficient	0.0
Rayleigh dampening (mass)	0.0
Rayleigh dampening (stiffness)	0.0
Longitudinal drag coefficient	0.0

OK Cancel

Anchor line

Edit Truss (305 Ankerline)

Information
WindLoads
Damper
Advanced

Name	
Component name	Ankerline
Component description	84mm

Properties	
E-modulus	2.1E9 N/m ²
Area	3.15E-3 m ²
<input type="checkbox"/> Volume	3.15E-3 m ³
Mass density	4.7619E4 kg/m ³
Weight in air	150.0 kg/m
<input type="checkbox"/> Weight in water	146.77125 kg/m

Drag loads	
Diameter Y	0.084 m
Diameter Z	0.084 m
Drag coefficient Y	1.2
Drag coefficient Z	1.2
Added mass coefficient Y	1.0
Added mass coefficient Z	1.0

Default values	
No compression forces	<input type="checkbox"/>
Pretension	0.0
Breaking Load	0.0 N
Material Coefficient	0.0
Rayleigh dampening (mass)	0.0
Rayleigh dampening (stiffness)	0.0
Longitudinal drag coeff	0.0

OK Cancel

APPENDIX B – CD

Content of the attached CD-rom:

- Full thesis and article draft in PDF-format
- Excel spreadsheet with time series
- Models used for all study cases(5)

APPENDIX C – Article draft

APPENDIX C – Article draft

Investigation of tensile forces in anchor lines and influence on vessel behaviour [Article draft]

Petter Langeland (M.Sc Ship Design)

Email: petter.svardal.langeland@gmail.com

ABSTRACT

This paper is based on a master's thesis where case studies were done to investigate the effects of mooring line on vessel response using time-domain analysis. The model is resembling a barge and is, together with a mooring line configuration, modelled in AquaSim [1], a time domain FEA (Finite Element Analysis) software developed by Aquastructures AS. A part of the project was to check how suitable the software is for this kind of analysis. The paper focuses on how the variation in mooring line length, direction and position and acting tensile force affect the vessel in regard of heave-, -roll and pitch-motion. In the analysis the model is under subject to varying loads from the mooring line, waves and current.

The works shows that the mooring line and barge are subjects to large variations in force and motions and that there are some connections between the tensile force and roll and pitch motion.

AquaSim shows great versatility when it comes to mooring-related analyses, with the aquaculture industry as one of its biggest users. As it is claimed that it is capable of performing dynamic analysis of vessel motion there are some limitations regarding the model as it was, at the current point, not possible to implement a realistic hull to analyse. RAO data from MARINTEK vessel response software ShipX but the prescribed motions could not be influenced by the mooring line. As a result, a barge was chosen as test model.

INTRODUCTION

Anchor Handling is one of the most complex operations done by offshore ships in the North Sea as it demands a lot from both crew and vessel. Under operation the vessel is affected by a number of different forces varying in both size and direction which puts high strain on stability as well as affecting the structure and equipment. In April 2007 the AHTS vessel "Bourbon Dolphin" capsized while deploying an anchor for the semi-submersible rig "Transocean Rather" 75 nautical miles northwest from Shetland, resulting in the death of 7 people. The commission set up for the investigation highlighted several factors that contributed to the capsizing but

in the end it was the loss of stability that caused it[2,3]. As a result of this the Norwegian Maritime Directorate proposed several changes in rules and standards to be implemented in the design process and operation of AHTS vessels to prevent similar situations to happen again.

This master thesis aims to give an overview of how these forces affect the stability under operation.



Figure 1 Bourbon Dolphin

Anchor Handling Vessels(AHV)

are multi-utility vessels which are mainly built to handle anchors and performing towing operations. These operations are often related to oil rigs where towing them to their location to anchor them up are some of the main tasks however, they are also used to transport supplies between offshore installations and mainland as well as support in emergency situations at sea and performing ROV-services. Due to the nature of an AHTS vessels work, there are high requirements when it comes to manoeuvrability, stability, and pulling power/Bollard pull. The vessel design is characteristic and with a steering house, and winch house in front of a large deck area with barriers on the side to protect the crew and equipment. The stern is open and enforced with a stern roller to handle chains grinding on the edge. Further explanation of the equipment is found later in this chapter. The length can vary from 50 metre to well over 100 m with a width of 15-25 metres. Bollard pull can vary from 60 tonnes on the smallest ones to over 400 tonnes on the bigger and most advanced ships

AHV operations

Anchor handling operations are in this project divided into two rough phases; deployment and recovering of anchors. Deployment of the anchor is often done by the vessel towing the anchor line from the rig to a given position. At the position the anchor is connected and lowered into the ocean using the working line from the winch. The weather condition is critical as the AHV is already exposed to large forces from the anchor line, depending on the length of the line. To handle the addition of waves, current and side winds it is critical for the vessel to have enough stability. The recovery of the anchor is more or less the reverse process of deploying it. The AHV drag the anchor loose from the seabed and starts to winch up the anchor and simultaneously reversing as the rig pulls the mooring line [4]

Vessel response (RAO)

When a vessel encounters a wave it will be displaced in one or several directions depending on the direction of the wave. For regular waves the elevation of this wave can be defined as [3]

$$\zeta = \zeta_a \sin(\omega t)$$

where ζ_a is the amplitude of the wave and ω is the wave frequency.

In any given reference point on the vessel, i.e. the LCG, there will be a displacement as a reaction to the vessel encountering the wave. This displacement will be slightly different from the wave elevation and the relation between these two can be described by response amplitude operators (RAO) or mathematically Transfer functions given as

$$\eta_k(t) = \eta_{ka} \cos(\omega t + \theta_k), \quad k = 1, \dots, 6.$$

where η_{ka} is the motion amplitude per unit wave amplitude and θ is the phase angle.

The hydrodynamic loads are calculated by linear strip theory in both AquaSim and ShipX. This is done by considering the floating body being made up of several two-dimensional sections, or strips, which in all together make up the whole shape of the hull. According to [5], each of these sections can be considered treated as a section of a floating, infinitive cylinder with a linear boundary problem and hydrodynamic effects calculated and solved for each of them. For the elements with this load definition, diffraction and radiation forces from waves are taken into account.

Load calculations

In the program the barge is defined for hydrodynamic loads which means that linear strip theory is used to calculate the loads as described in[6].

For the mooring line, Morison load calculations will be used as defined in[6]

$$F_2 = \frac{\rho_w C_{dy} Diam_N L_0}{2} (u_2 - \dot{v}_{2m})$$

$$* \sqrt{(u_2 - \dot{v}_{2m})^2 (u_3 - \dot{v}_{3m})^2} + \rho_w (1 + C a_y) V_{2D} L_0 a_2 - \rho_w C a_y V_{2D} L_0 \ddot{v}_2$$

BARGE MODEL

Geometry

The properties of a box-shaped Barge of considerable size makes it very stable in water as it has a GM much higher than what is found on vessels with more hydrodynamic shape. Based on hand-calculations, the main dimensions are chosen with respect to the GM which was aimed to be around 1.5-1.9. The dimensions are presented in table 1.

Parameter	Abbr.	Value
Length	L	80 [m]
Breadth	B	18 [m]
Depth	D	8 [m]
Draught	T	5 [m]
VCG	-	6 [m]
GMt	-	1.9 [m]

Table 1

RESULTS

Motion verification

To verify the dynamic movements of the model and make sure that the values can be taken directly from the analysis the analysis is done both in AquaSim and ShipX for comparison. ShipX is a renowned program for calculating ship response and similar motions between the programs will confirm the legitimacy of the results in AquaSim. This is done by running a "vessel response" in ShipX for the barge model and a simulation in AquaSim. The values in AquaSim are found from reading the stabilized values for rotation and displacement for the given wave headings with the measurements done from the CoG. The simulations are performed with waves approaching from different directions, in this case 0 and 90 degrees known as head- and beam sea respectively

As Figure 2 and 3 shows the data from AquaSim corresponds well with the data from ShipX with some deviation found for roll movements

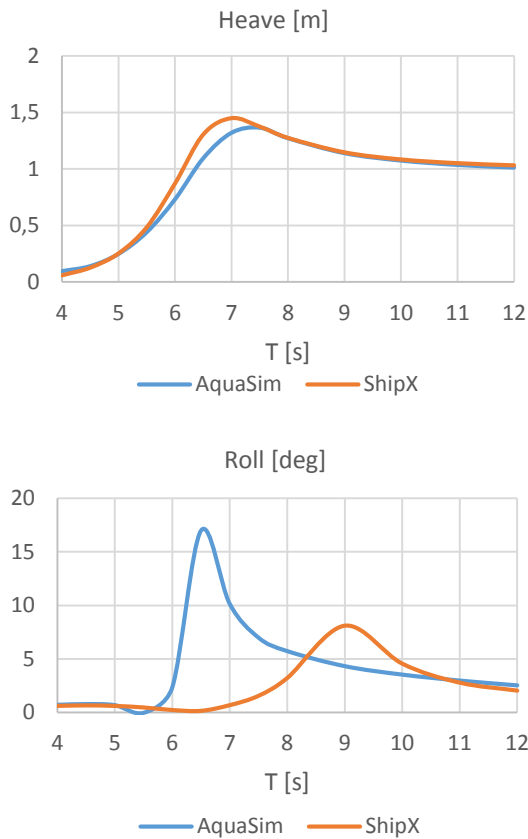

Figure 2 Heave and roll motion in beam sea

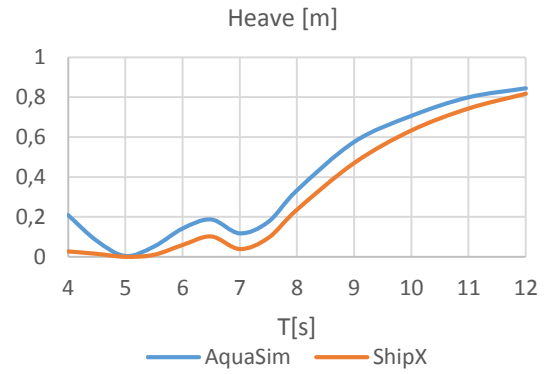
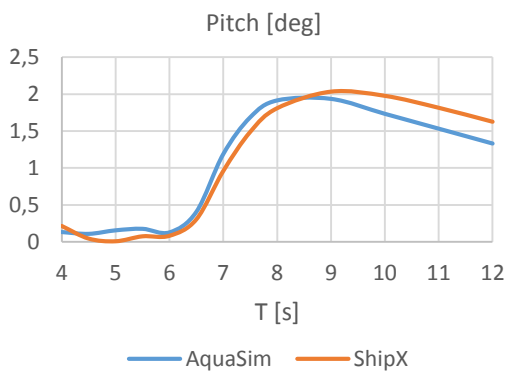

Figure 3 Pitch and heave motion in head sea

Case study 1

The vessel is placed 340m from the OI with the total length of the mooring line at 525m with its lowest point at 200m, leaving the stern with an angle of 40 degrees. The anchor is considered resting the stern. Figure 4 shows that the addition of the mooring line induces a small static angle in regard of pitch motion in head sea. In this case that angle is measured to be -0.2 degrees, meaning that the vessel is operating with a slight negative trim. The largest pitch motion in head sea is found at T=9 seconds as indicated in

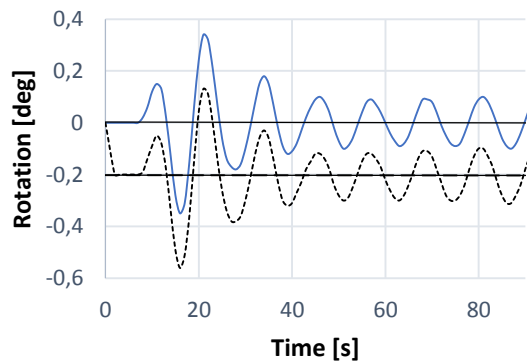

Figure 4 Pitch motion

Case study 2

In this case study the vessel is placed about 3250m from the IO with the total length of the mooring line at approximately 3500m with the lowest point at 650m depth. In addition to the previously used environmental loads, the effect of current is also considered. Figure 5 shows the roll motion found for T=6.5s.

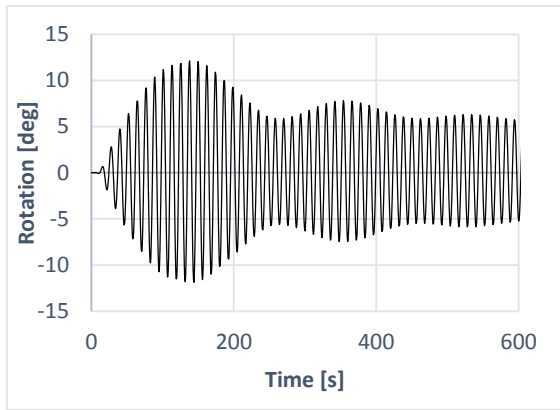

Figure 5 Roll motion for T=6.5s

When comparing roll and pitch motion, some similarities could be seen as the peaks occurs at approximately the same time. Figure 6 presents the pitch motion found for T=6.5 seconds.

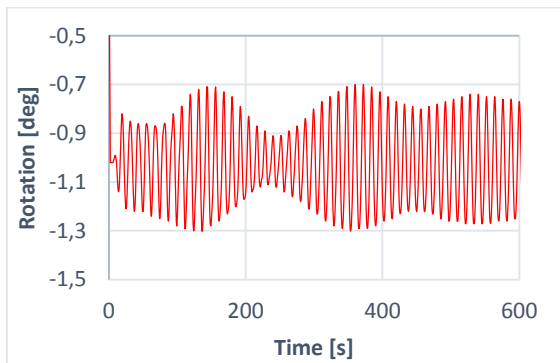

Figure 6 Pitch motion for T=6.5s

Figure 7 presents the mooring line force at T=6.5s. As with the roll and pitch motion, the peak of the force just before 200 seconds. The amplitudes are then varying in a pulsating pattern. Figure 8 shows the same series with varying wave amplitude which shows that there is much more instability.

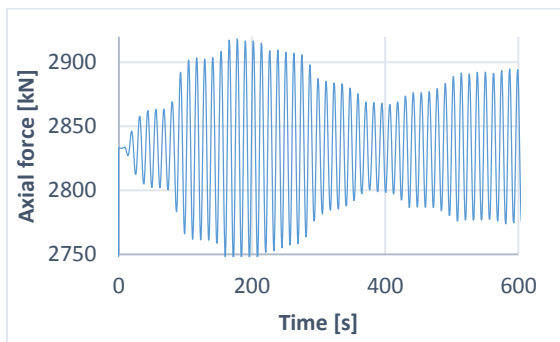

Figure 7 Axial force for T=6.5s

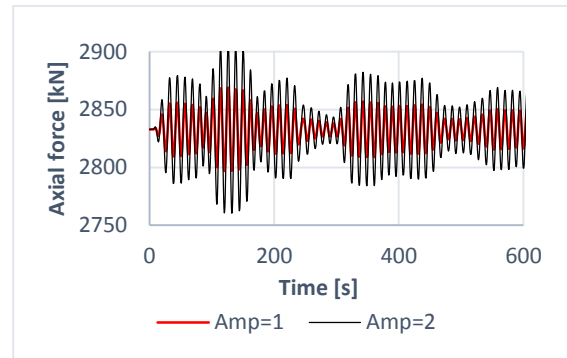

Figure 8 Axial force with wave amplitude 1m and 2m.

Case study 3

Vessel positioned as in Case #2 but with the anchor now hanging from the stern at about 340m depth. Previous environmental loads apply. There were no significant changes in vessel response from case #2 to #3.

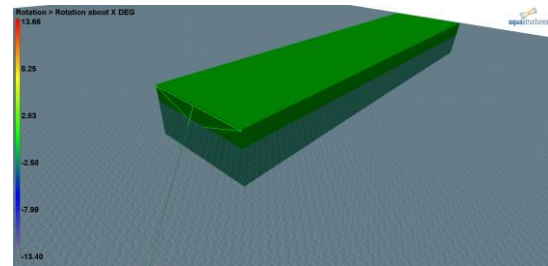

Figure 9 Study Case #3

Figure 12 presents the measured roll motions for the different cases. The figure shows that the peak of the roll period is increasing from 6.5 seconds in case #0 and #1 to 7 seconds for case #2, #3 and #4.

Case study 4

A fourth study case was analysed with the mooring line leaving the stern at varying angles, namely 60 and 36 degrees. An offset of 1.8m from the barge centre line was also set. Figure 10 presents a summary of all the cases. It shows that the natural roll period of the barge has shifted from 6.5 seconds to 7 seconds which is expected as the extra load is affecting the barges range of motion.

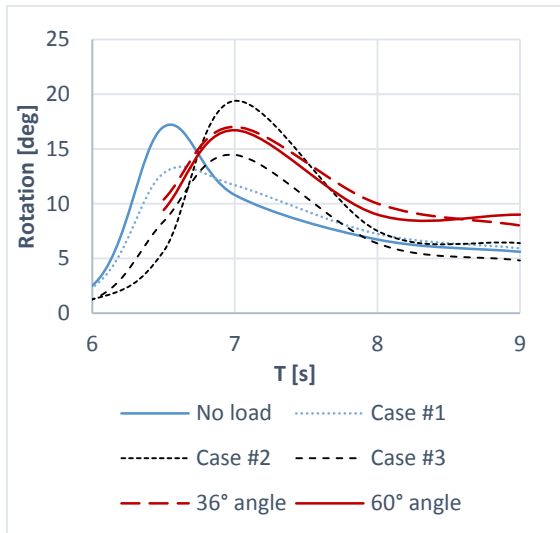

Figure 10 Roll motion for different cases

Figure 11 presents the axial forces measured for case #2 and #3. The figure indicates that, as expected, the highest force is found in case #2 where the mooring line is longer however, the addition of current [1m/s] does not change the force noticeably. In case #3 where the anchor is dropped in the ocean, the force has decreased with about 200 kN. This is most likely due to the force being measured in a different material, as it is now the work wire that pulls in the barge.

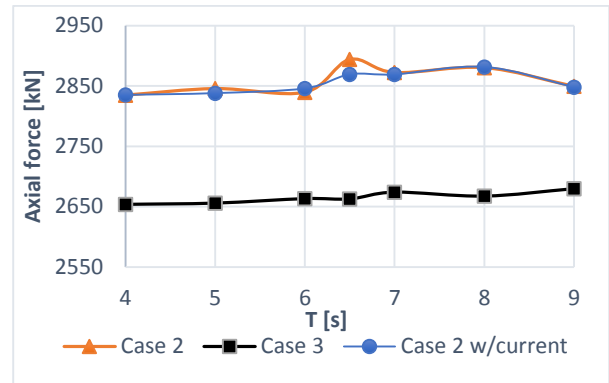

Figure 11 Axial forces from different cases

CONCLUSION

A final model resembling a barge with a mooring chain and working line have been modelled and simulated in AquaSim for some specific load cases. The software has some limitations which is why a barge was used.

The barge was analysed in both AquaSim and ShipX where the comparison shows that there are some differences in the analysis setup as there is a large deviation in roll motion.

Study cases were set up and analysed to investigate the mooring lines effect of the barge response under varying environmental loads. The simulations show that the barge is subject to great amount of forces from the mooring line, with varying differences of up to 200 kN found for specific conditions. Added loads such as current and increased wave height made the forces and response more unpredictable.

REFERENCES

- [1] Aquastructures AS, "The AquaSim Package User Manual". (2014)
- [2] NOU, Norges offentlige utredninger, "Bourbon Dolphins forlis den 12. april 2007." (2008)
- [3] Sjøfartsdirektoratet, "Rapport om tiltak for ankerhåndteringsfartøy og flyttbare innretninger." (10.02.2009)
- [4] M. Hancox and H. Clarkson, "Anchor Handling" (2011).
- [5] MARINTEK AS, "ShipX Vessel Responses (VERES) User's Manual" (2015).
- [6] J.A. Berstad, "Theoretical formulation of structure and load modelling, Report no.2006-301"(2006)