

13th Deep Sea Offshore Wind R&D Conference, EERA DeepWind'2016, 20-22 January 2016, Trondheim, Norway

## Investigation on Fault-ride Through Methods for VSC-HVDC Connected Offshore Wind Farms

Wenye Sun<sup>a,c,\*</sup>, Raymundo Enrique Torres-Olguin<sup>a,b</sup>, Olimpo Anaya-Lara<sup>a,b</sup>

<sup>a</sup>Norwegian University of Science and Technology, Trondheim, Norway

<sup>b</sup>SINTEF, Trondheim, Norway

<sup>c</sup>Delft University of Technology, Delft, Netherlands

### Abstract

This paper proposes a novel fault-ride through method for offshore wind farms connected to grid through a voltage source converter (VSC)-based high voltage direct current (HVDC) transmission. The proposed method introduces a controlled voltage drop at offshore grid when an onshore fault occurs. The idea behind is to achieve a fast power reduction. Additionally in the proposed idea, every individual wind turbine detects the voltage drop of offshore grid almost simultaneously, then its controller decreases the power set-point to reduce the power output from each wind turbine. The effectiveness of this method is verified by numerical simulations performed in PSCAD.

© 2016 The Authors. Published by Elsevier Ltd. This is an open access article under the CC BY-NC-ND license

(<http://creativecommons.org/licenses/by-nc-nd/4.0/>).

Peer-review under responsibility of SINTEF Energi AS

**Keywords:**

offshore wind farm (OWF); voltage source converter (VSC); high voltage direct current transmission (HVDC); fault-ride through (FRT)

### 1. Introduction

Nowadays, offshore wind farms (OWFs) have shown a rapid development, because of good wind condition, less visual impact, and large space [1]. OWFs are usually located far from load centers, so long transmission cables are required. Moreover, the capacity of these wind farms becomes larger and larger. For such offshore network, where large power will be transmitted over long distance, application of high voltage direct current transmission (HVDC) is considered the most suitable technology [2].

There are two HVDC technologies, i.e. current source converter (CSC) HVDC and voltage source converter (VSC) HVDC. CSC uses line-commutated switching device, which has some limitations, for example it needs reactive power compensation devices resulting in a bulk converter station. Modern HVDC transmission systems use VSC, which is self-commutated device. This means that in VSC, the current can be made lag or lead the ac voltage, so the converter can consume or supply reactive power to the connected ac network eliminating the reactive power compensation

\* Corresponding author. Tel.: +008618101195012.

E-mail address: [wenye.sun@cn.abb.com](mailto:wenye.sun@cn.abb.com)

devices [3]. It can also make it possible to control the active power and reactive power independently [4]. Furthermore, 1 to 2 kHz high switch frequency of pulse-width modulation (PWM) reduces the filtering requirements and power flow can be reversed without the need to reverse the dc-link voltage. All these advantages show VSC is good option for HVDC transmission.

When an offshore wind farm (OWF) is connected to main grid through VSC-based HVDC, the HVDC voltage is controlled by the onshore HVDC converter which transfers the power to the onshore ac network. When a fault occurs at the ac grid, the onshore converter is unable to transmit all the active power to the ac grid, but OWF still injects active power to offshore converter, which will result in power imbalance between onshore converter and offshore converter. The resulting power imbalance will charge the capacitance in the dc-link. Without any actions, this will result in a fast increase of the dc voltage, which may damage the HVDC equipment. Therefore some strategies should be taken to regulate the power imbalance.

Some methods have already been discussed in previous studies, i.e. chopper resistor method, power setpoint adjustment method, active current reduction method, and offshore voltage reduction method [5][6][7][8]. Chopper resistor method limits dc-link voltage by dissipating the imbalanced power as heat. The main advantage of this approach is that OWFs stay completely unaffected by the fault. However, a large chopper resistor is very costly. The second and third methods are implemented by sending a de-loading signal to each wind turbine when fault occurs. The difference is with power setpoint adjustment method, the de-loading signal is sent to wind turbine converter to control the power directly. With active current reduction method, the de-loading signal is sent to wind turbine converter to control active current. There is some communication delay, which will reduce the effectiveness of these two methods. Offshore voltage reduction method initiates a controlled voltage drop by offshore converter to achieve a fast power reduction. However, an abrupt voltage reduction leads to similar phenomena like a fault within OWF grid [5], which will increase the dc voltage in the back-to-back converter of wind turbine. This paper will propose another fault-ride through (FRT) method, which combines power setpoint adjustment method and offshore voltage reduction method, but the communication delay is eliminated and the over-voltage control ability of HVDC is highly improved.

This paper is structured as follows: Section 2 presents a test system that is used to implement the novel FRT method. Section 3 gives a detailed design of HVDC converter controller. Section 4 explains the control system for wind turbine including generator side converter control and ac grid side converter control. Section 5 presents a novel FRT method. Section 6 evaluates the proposed FRT method with a case study. A final conclusion is drawn in section 7.

## 2. Test system

Two OWFs with capacity of 300 MW and 200 MW connected to the onshore grid via VSC-HVDC is considered as the test system, shown in Figure 1. The simulation has been conducted with PSCAD. The system mainly consists of OWFs, VSC, dc cable, and onshore grid. The OWF is simulated using aggregate model. The equivalent single unit is equipped with a permanent magnet synchronous generator (PMSG) and a back-to-back converter. The rated output voltage of the generator is 0.69 kV. The switching frequency for the back-to-back converters is 2500 Hz. The VSC is a two level converter with a switching frequency of 2000 Hz. A phase reactor of 0.15 pu has been used and the corresponding inductance value is 0.05H. The nominal dc-link voltage is 500 kV and the dc capacitor is 20  $\mu$ F. Cross-linked Polyethylene (XLPE) cables are used in this VSC-HVDC transmission and its length is 100 km. During the simulation in PSCAD, the cable uses frequency dependent (phase) model. The onshore grid is represented by voltage source of 400 kV at 50 Hz with short circuit ratio (SCR) of 10 and the grid angle of 84.3°.

## 3. Control design for VSC-based HVDC

This section mainly focuses on the design of VSC controllers which is used for integration OWF to onshore grid. It includes the controller of offshore converter which connects the OWF and the controller of onshore converter which connects the main onshore grid.

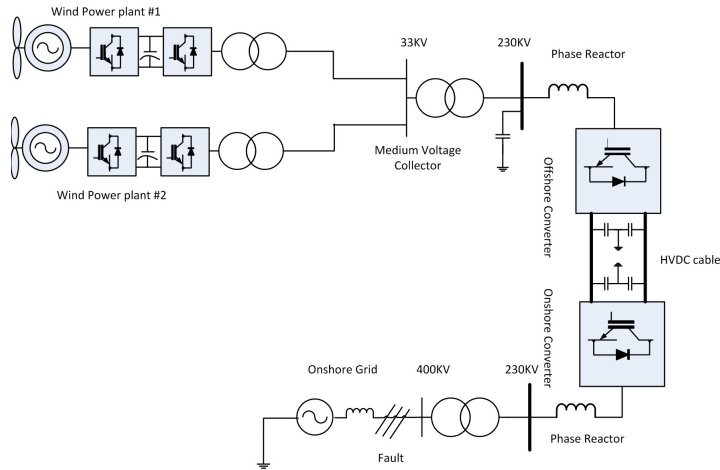

Fig. 1: Test system

3.1. Offshore converter controller design

When VSC-HVDC connects to OWF, because the wind turbines can control active power and reactive power by themselves, the basic function of the offshore converter controller is to maintain the ac voltage and frequency of the OWF grid. In other words, the offshore converter behaves like an infinite bus bar, all the power produced by the OWF can be absorbed automatically and transmitted to the onshore main grid.

The circuit diagram of OWF connected offshore converter and its controller is shown in Figure 2. All the parameters are in dq reference frame. The controller consists of inner loop control and outer loop control. For inner loop, the error between the reference current and the measured current is through a Proportional-Integral (PI) to produce the reference voltage for the input of converter. For outer loop, the error between the reference voltage and the measured offshore grid voltage can be used to produce the current reference through a PI controller [9].

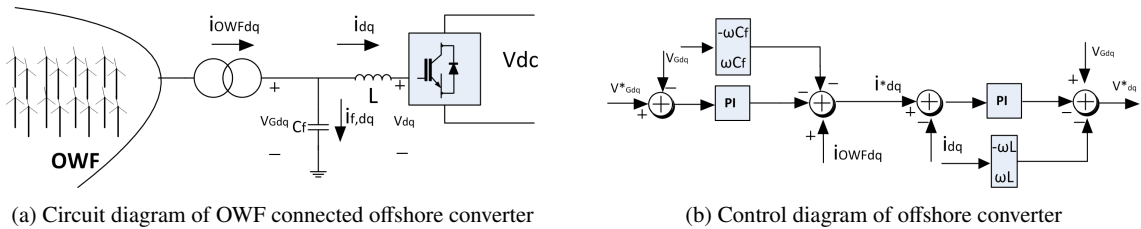

Fig. 2: Offshore converter and its control

3.2. Onshore converter controller design

In normal operating conditions, the control objective of onshore converter is to regulate the dc-link voltage which enables transfer the power from OWF to the onshore grid. During onshore grid dips, the onshore converter should regulate the reactive power to provide voltage support.

3.3. Onshore converter controller design

The circuit diagram of onshore converter connected onshore grid and its controller are shown in Figure 3. All the parameters are in dq reference frame. The inner loop controller is similar with that of offshore converter. A PI is adopted and the governing equation produce the voltage reference for the converter ( $U_d^*$ ,  $U_q^*$ ) in the inner current



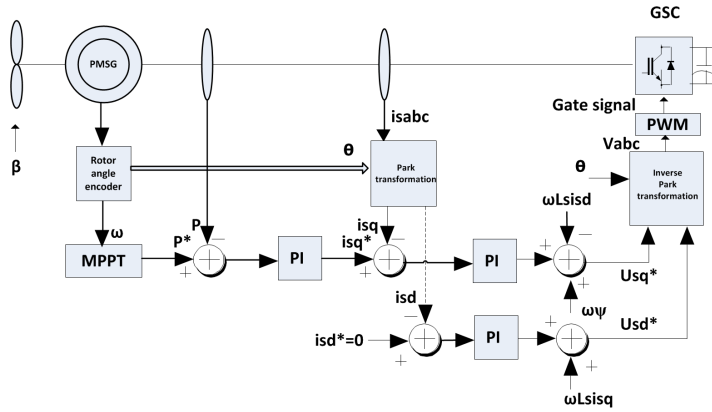

Fig. 4: Control diagram of generator side converter controller

#### 4.2. AC grid side converter control

The control objective of ACGSC is to maintain the dc-link voltage and control the reactive power. The controller is shown in Figure 5.

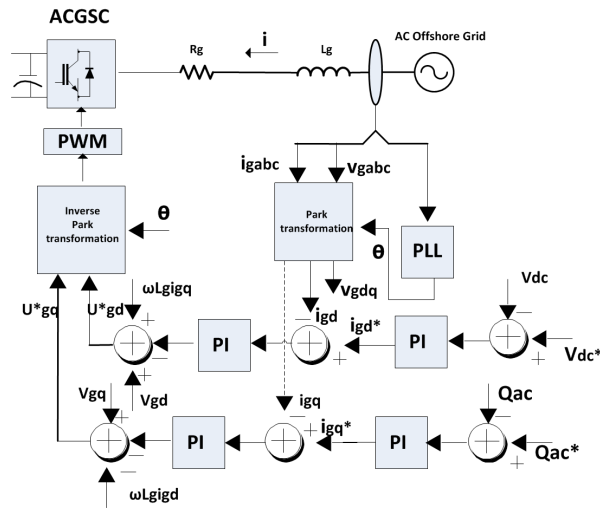

Fig. 5: Control diagram of ac grid side converter controller

The inner loop control is similar with the controller of GSC. A PI controller is adopted and the governing equation produces the voltage reference for the converter ( $U_{gd}^*$ ,  $U_{gq}^*$ ) in the inner current loop. For outer loop, The difference between the reference dc voltage and the voltage measured at the dc-link will be applied to a PI controller and the output will be used as the reference of  $i_{d}$ . In a similar way, the reference for q-axis will control the reactive power flow and the difference between reference reactive power and measured reactive power will be used to produce the reference of  $i_{q}$ .

## 5. Proposed Fault Ride through Method

This section mainly refers to a novel FRT method. It will be explained in the following in detail. The overall control structure is shown in Figure 6, When an onshore fault occurs, the dc voltage at the offshore converter will increase. When the dc-link voltage exceeds its threshold value, it will activate the controller of offshore converter to control offshore ac voltage magnitude, implemented by block VRC, based on equation (2).

$$V_{ac} = V_{ac,ref} - k_v(V_{dc,ref} - V_{dc}) \quad (2)$$

where  $V_{ac}$  is the calculated offshore ac voltage magnitude during fault,  $V_{ac,ref}$  is the ac voltage magnitude reference during steady state,  $k_v$  is the droop gain that adapts the dc to the ac offshore voltage,  $V_{dc,ref}$  is the steady state dc voltage reference and  $V_{dc}$  is the actual dc voltage magnitude.

Almost at the same time, wind turbines detect the offshore ac voltage magnitude reduction. This will activate the wind turbine local controller. A power droop factor is generated and sent to GSC to de-load active power. The power droop factor is decided by rated offshore ac voltage magnitude and reduced offshore ac voltage magnitude, implemented by block PRC, based on the following equation (3).

$$K_p = \frac{V_{reduce}}{V_{rated}} \quad (3)$$

where

$K_p$  is the power droop factor,

$V_{reduce}$  is the reduced offshore ac voltage magnitude,

$V_{rated}$  is the rated offshore ac voltage magnitude.

This reduction factor can also be implemented on the active current controller of GSC. By controlling the active current instead of controlling the power setpoint, the system has faster response.

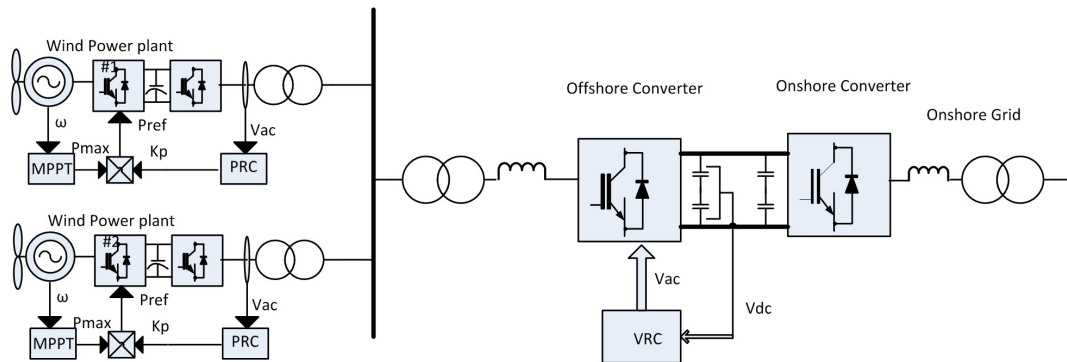

Fig. 6: Control structure of the novel fault-ride through method

There are three advantages of this novel FRT method:

First, in previous FRT methods [5] [6] [7], the power reduction factor for wind turbine is sent either from onshore converter by detecting the onshore ac voltage or from offshore converter by detecting the increase of HVDC-link voltage. These methods will have communication delay which limits the speed of power reduction. But in this new method, the power reduction factor is directly generated from each wind turbine based on the offshore voltage reduction, so there is no communication delay.

Second, if just blocking the power output from OWF by decreasing the offshore grid voltage implemented in [6] [7], it will lead behaves like a fault within the OWF grid, which will lead electrical stress on the wind turbine drive train. This new method combines offshore voltage reduction method and wind turbine power reduction method. There will be not too much power accumulating at the wind turbine back-to-back converter. As a result, the wind turbine drive train does not suffer from large electrical stress.

Third, with this novel method, when an onshore fault occurs, the power sent to offshore converter is blocked by offshore voltage reduction. And also the output power from each wind turbine is reduced by adjusting the wind turbine power setpoint or reducing the active current. The combined power reduction will largely improve the control ability of HVDC over voltage and limit the dc voltage within safety value.

## 6. Simulation result

In order to evaluate the effectiveness of this novel FRT method, a three phase to ground fault has been applied to the test system. The fault occurs at 10.5s and last for 200ms, and a small ground fault resistance is used.

Figure 7: simulation results during three phase to ground fault in the case of without method, with offshore voltage reduction method, and with the novel FRT method. a) onshore ac voltage, b) onshore active power, c) onshore dc-link voltage, d) onshore reactive power, e) offshore ac voltage, f) offshore active power, g) wind turbine back-to-back converter dc voltage, and h) wind turbine active power.

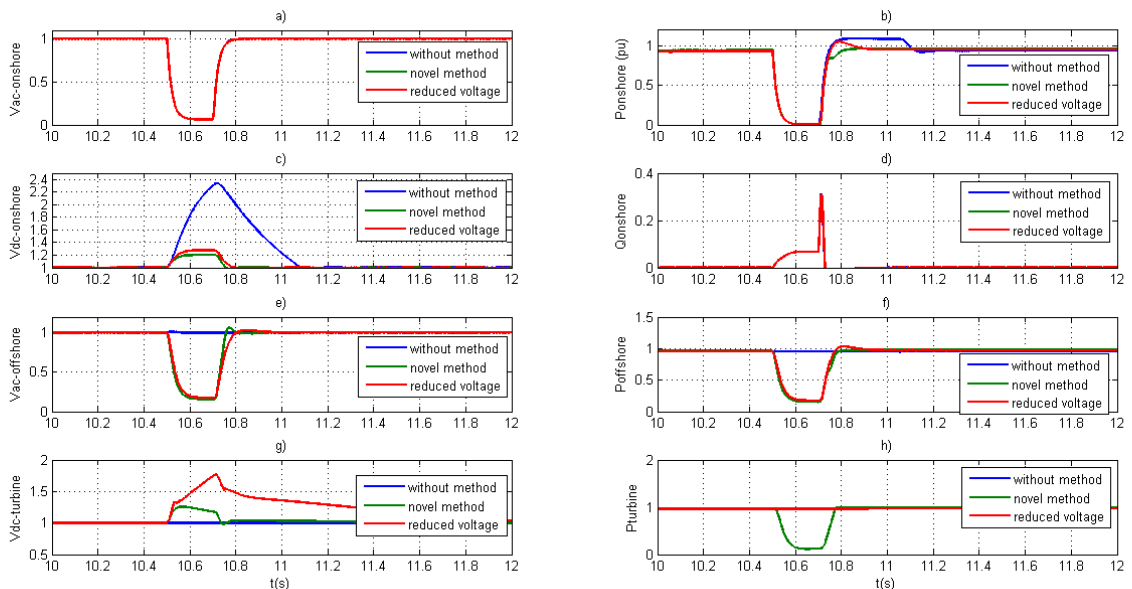

Fig. 7: Simulation results during three phase to ground fault without and with this fault ride through method

Figure 7 a) shows that, after a three phase fault occurs at 10.5s, the onshore ac voltage decreases to nearly zero as is expected, which results in zero active power output of onshore converter shown in Figure 7 b). Without any method, the dc-link voltage increases to 2.35 pu as shown in Figure 7 c). If the offshore voltage reduction method is applied, the dc-link voltage reduces to 1.27 pu. With the proposed method, the dc-link voltage reduces to 1.2 pu, which proves that this method is quite effective. Figure 7 d) shows when onshore fault occurs, onshore converter will produce reactive power to support grid voltage restoration. During the moment of onshore voltage recovering to normal value, there will be large reactive power drawn from onshore converter. There is no difference for reactive power generation among the three cases: i.e. without method, with offshore voltage reduction method, and with novel method. When the offshore voltage reduction method and the novel FRT method are applied, offshore ac voltage is reduced to 0.2 pu as shown in Figure 7 e). As a result, the power transmitted to offshore converter is reduced to 0.22 pu shown in Figure 7 f). With this novel method, when wind turbine detects offshore voltage reduction, a power reduction factor will be generated and sent to GSC to de-load the wind turbines. As a result, the active output power from each wind turbine is reduced without almost no delay, as shown in Figure 7 h). From Figure 7 g), it can be seen, if only

offshore voltage reduction method is used, the dc voltage of wind turbine back-to-back converter will increase to a very high value. This is because the wind turbines still produce power, while this power cannot be fully transmitted to offshore converter. The imbalanced power will accumulate in the wind turbine back-to-back converter, which lead to high dc voltage. While with this novel method, each wind turbine also decrease its power output. Therefore the dc voltage of wind turbine back-to-back converter is largely reduced. This case study proves that the novel method can control the HVDC over voltage effectively during onshore grid fault, and largely reduces the dc voltage of wind turbine back-to-back converter.

## 7. Conclusion

This paper proposed a novel FRT method for VSC-HVDC connected OWF system. This method allows a very fast OWF power reduction by decreasing the offshore grid voltage and almost at the same time the output power from each wind turbine is also reduced. The combined power reduction provides a very reliable protection of the HVDC system against the dc overvoltage.

## Acknowledgements

This research was performed as the result of my Erasmus Mundus master thesis and that the authors acknowledge the support from my supervisory team in TU Delft, Profs Pavol Bauer and Henk Polinder.

## References

- [1] Rousis A O, Anaya-Lara O. Dc voltage control for fault management in hvdc system[J]. Energy Procedia, 2015, 80: 237-244.
- [2] C. Ismunandar, "Control of multi-terminal vsc-hvdc for offshore wind power integration," Page.7, M.Sc thesis, Delft University of Technology, August 2010.
- [3] Bahrman, M.P. and Johnson, B.K, "The ABCs of HVDC transmission technologies", Power and Energy Magazine, IEEE, vol. 5, pp. 32-44, March 2007.
- [4] C. Bajracharya, "Control of vsc-hvdc for wind power," Page.7, M.Sc thesis, Norwegian University of Science and Technology, 2008.
- [5] C. Feltes, H. Wrede, F. W. Koch, and I. Erlich, "Enhanced fault ride-through method for wind farms connected to the grid through vsc-based hvdc transmiss- sion," Power Systems, IEEE Transactions on, vol. 24, no. 3, pp. 1537-1546, 2009.
- [6] G. Ramtharan, A. Arulampalam, J. B. Ekanayake, F. Hughes, and N. Jenkins, "Fault ride through of fully rated converter wind turbines with ac and dc trans- mission systems," IET Renewable Power Generation, vol. 3, no. 4, pp. 426-438, 2009.
- [7] S. K. Chaudhary, Control and Protection of Wind Power Plants with VSC- HVDC Connection. Page 70-77, PhD thesis, Aalborg University, Aalborg, Denmark, 2011.
- [8] B. Silva, C. Moreira, H. Leite, J. Lopes, et al., "Control strategies for ac fault ride through in multiterminal hvdc grids," Power Delivery, IEEE Transactions on, vol. 29, no. 1, pp. 395-405, 2014.
- [9] R. E. T. Olguin, "Grid integration of offshore wind farms using hybrid hvdc transmission: Control and operational characteristics," Page 88-91, PhD thesis, 2013.
- [10] S. I. Nanou, G. N. Patsakis, and S. A. Papathanassiou, "Assessment of communication-independent grid code compatibility solutions for vsc-hvdc connected offshore wind farms," Electric Power Systems Research, vol. 121, pp. 38-51, 2015.
- [11] B.E.ON Netz GmbH, "Grid code high voltage and extra high voltage", Page 16-19, 2006.