



Norwegian University of
Science and Technology

Prototyping and testing of novel flood protection systems

Kristian Vemund Haaland
Øystein Blix Walderhaug

Master of Science in Mechanical Engineering

Submission date: June 2016

Supervisor: Torgeir Welo, IPM

Norwegian University of Science and Technology
Department of Engineering Design and Materials

**MASTER THESIS SPRING 2016
FOR
STUD.TECHN. Øystein Walderhaug and Kristian Vemund Haaland**

Prototyping and testing of novel flood protection systems

Prototyping og testing av nye flomvern-system

Aquafence is a Norwegian company that develops and manufactures mobile flood protection systems that are certified and tested according to international standards. The market for flood protection systems has experienced considerable growth in recent years. In the wake of natural disasters such as Hurricane Sandy in New York City and general increasing frequency and severity of floods globally, incentives for deploying flood protection systems have been made explicit through legislations and insurance discounts. This trend is expected to continue, thus making flood protection systems attractive for consumers as well as companies, cities and municipalities. Since AquaFence's current products are mainly intended for large applications and extreme flood levels (up to 240 cm) it is desirable to develop a new, less expensive and smaller scale system to target the consumer market.

The overall goal of the AquaFence project is to develop an all-new flood protection system. As part of earlier project work, several new product and test-setup concepts have been developed along with user-scenarios. The main task going forward is to validate and verify these new concepts while continuing to explore alternatives.

The project is in a phase where functional prototyping and testing is necessary to make progress. Therefore, the overall goal of this master thesis is to design, develop and test functional prototypes of novel product concepts for the new flood protection system. In line with set-based design principles, multiple solutions are expected.

The project consists of the following tasks:

- Conduct a literature study on prototyping and experimentation
- Design and build a functional test-setup for full-scale prototypes, along with test procedures for rapid, iterative testing
- Develop new, innovative ways for testing desired aspects of new concepts, e.g. sealing between system and a variety of ground surfaces
- Design and build physical prototypes of new flood protection concepts
- Verify and validate prototypes of the system (and sub-systems) by conducting testing in a test rig

Formal requirements:

Three weeks after start of the thesis work, an A3 sheet illustrating the work is to be handed in. A template for this presentation is available on the IPM's web site under the menu "Masteroppgave" (<https://www.ntnu.edu/web/ipm/master-thesis>). This sheet should be updated one week before the master's thesis is submitted.

Risk assessment of experimental activities shall always be performed. Experimental work defined in the problem description shall be planned and risk assessed up-front and within 3 weeks after receiving the problem text. Any specific experimental activities which are not properly covered by the general risk assessment shall be particularly assessed before performing the experimental work. Risk assessments should be signed by the supervisor and copies shall be included in the appendix of the thesis.

The thesis should include the signed problem text, and be written as a research report with summary both in English and Norwegian, conclusion, literature references, table of contents, etc. During preparation of the text, the candidate should make efforts to create a well arranged and well written report. To ease the evaluation of the thesis, it is important to cross-reference text, tables and figures. For evaluation of the work a thorough discussion of results is appreciated.

The thesis shall be submitted electronically via DAIM, NTNU's system for Digital Archiving and Submission of Master's theses.

The contact persons are Post Doc. Christer Elverum, IPM and Fred Dahl (CEO, Aquafence)



Torgeir Welo
Head of Division



Torgeir Welo
Professor/Supervisor



NTNU
Norges teknisk-
naturvitenskapelige universitet
Institutt for produktutvikling
og materialer

Abstract

This thesis describes the early development stages of novel consumer flood protection systems. The development process has emphasized prototyping and experimentation as a strategy to front-load the development, which is outlined by a literature study.

A framework for the development and a set of quantitative and qualitative measures for the systems being designed were established. The development has been based on rigid-flexible hybrid systems, combining desired aspects from each.

As consumer flood protection systems represent an immature market with little knowledge to base the development on, generating and capturing knowledge has been a priority. Furthermore, the thesis describes the development and application of a program for capturing and reusing the knowledge obtained during this project. Knowledge was primarily gained through prototyping and by designing and conducting experiments.

The feasibility of using PVC canvas in hybrid systems in terms of stability was investigated. The test setup used to investigate this also showed great potential for testing overall stability of systems. In addition, a new innovative way for testing gaskets, independent of system design, was designed and performed.

Lastly, the thesis describes two promising concepts for consumer flood protection systems and points out further work that needs to be completed in order to move the products towards industrialization.

Sammendrag

Denne avhandlingen beskriver de tidlige utviklingsstadiene av nye flomvernssystemer beregnet for forbrukermarkedet. I utviklingsprosessen har prototyping og eksperimentering blitt brukt som strategier for “front-loading” av utviklingen, disse strategiene er introdusert i litteraturstudiet.

Et rammeverk for utvikling, og et sett med kvantitative og kvalitative mål for systemene ble etablert. Arbeidet har tatt for seg hybrider av rigide og fleksible systemer som kombinerer ønskede egenskaper.

Flomvernssystemer rettet mot forbrukere representerer et umodent marked med lite kunnskap tilgjengelig å basere utviklingen på. Derfor har det å generere og fange kunnskap vært en prioritet.

Videre beskriver oppgaven utviklingen og anvendelsen av et program for å fange og gjenbruke kunnskap tilegnet i løpet av dette prosjektet. Kunnskap har primært blitt opparbeidet gjennom prototyping, og ved å designe og gjennomføre eksperimenter.

Muligheten for å bruke PVC-duk i hybridsystemer med tanke på stabilitet ble undersøkt. Testoppsettet som ble brukt til å undersøke dette viste seg også å ha et stort potensial til å teste stabiliteten til systemer. I tillegg ble en ny innovativ måte for å teste pakninger, uavhengig av systemdesign, designet og utført.

Til slutt beskriver oppgaven to lovende konsepter for forbruker-flomvernssystem, og påpeker videre arbeid som må utføres for å bringe disse nærmere industrialisering.

Acknowledgements

We would like to express our gratitude to our supervisor professor Torgeir Welo and AquaFence CEO Fred Dahl for giving us the opportunity to work with this project.

We are particularly grateful for the assistance given by Postdoc. Christer W. Elverum and PhD-candidate Sigmund A. Tronvoll.

Thank you!

Table of Contents

1	INTRODUCTION	1
1.1	Background	1
1.2	Objectives.....	1
1.3	Project Structure.....	2
2	LITERATURE STUDY: PROTOTYPING AND EXPERIMENTATION IN PRODUCT DEVELOPMENT	3
2.1	Purpose.....	3
2.2	What is a prototype	3
2.3	Classifying prototypes.....	4
2.4	The purpose of prototyping	8
2.5	Experimentation	10
2.6	Decisions about prototyping and fidelity of prototypes.....	13
3	UNDERSTANDING THE CONTEXT OF FLOODS.....	15
3.1	What causes floods.....	15
3.2	The global impact of floods	15
3.3	The forms of flood protection	16
3.4	Finding an Alternative to Sandbags	17
3.5	Categorization of temporary flood protection systems	19
3.6	AquaFence.....	22
3.7	The Market for a New Type of Flood Barrier	24
4	ESTABLISHING A FRAMEWORK FOR THE DEVELOPMENT PROCESS.....	25
4.1	Development strategy.....	25
4.2	Choosing a direction for the development	28
4.3	Failure mechanisms as design guidelines.....	30

4.4	Outlining the Key mechanisms	32
4.5	Other considerations for development	37
4.6	Summary of design restrictions.....	39
5	GAINING AND CAPTURING KNOWLEDGE	41
5.1	The value of capturing knowledge	41
5.2	Developing a Knowledge Capturing System	42
5.3	Investigating the contribution of canvas towards stability.....	46
5.4	Investigating the seepage rates for different gaskets.....	50
6	CONCEPT DEVELOPMENT	65
6.1	Resources	65
6.2	Early phase concept development	68
6.3	Tetris.....	69
6.4	Caterpillar.....	80
6.5	FlexiFront.....	87
6.6	Evaluation of concepts	91
6.7	Further work and industrialization of concepts.....	94
7	CONCLUSION	97
8	REFERENCES	99
	APPENDICES	103
	Appendix A - Code for the Knowledge Capturing System.....	105
	Appendix B - Equations used to establish relationships for Tetris	107
	Appendix C - Arduino code for automated gasket experiment.....	109
	Appendix D - Documentation from initial development	111
	Appendix E - Risk assessment form	137

1 Introduction

1.1 Background

The market for flood protection systems has seen considerable growth in recent years. In the wake of global natural disasters with increasing frequency and severity, the demand for flood protection solutions is increasing.

AquaFence is a Norwegian company specializing in development and production of flood protection systems that are tested and certified according to international standards. The company is currently offering temporary medium- and large-scale systems. Since AquaFence's current products are mainly intended for large-scale applications and extreme flood levels, it is desirable to develop a new, inexpensive system targeted at the consumer market.

Consumer flood protection systems represent an immature, and partially unexplored market, demanding products that differ greatly from the products AquaFence currently offers. The company will therefore benefit from a new product designed from the ground up.

1.2 Objectives

As AquaFence is a relatively small company with limited resources, their development efforts mainly target incremental improvements of existing products. The circumstances of this project allow a more scientific approach to development, that includes experimentation to generate reusable knowledge that can be of great value to the company. Therefore, in addition to generating promising concepts for consumer flood protection barriers, a system generating reusable knowledge will be developed.

This project aims to attain the following objectives:

- I. Develop novel concepts for consumer flood protection barriers
- II. Develop new innovative ways for testing desired aspects of new concepts
- III. Design and build a functional test set-up for comprehensive prototypes
- IV. Establish a system for capturing knowledge gained during development

1.3 Project Structure

Chapter 2 presents a literature study on prototyping and experimentation. This is to gain an understanding of the different methods that exist for prototyping and experimentation so that they can be used in the best way possible to aid the development of a new flood protection system. Chapter 3 outlines facts about floods and establishes the types of flood protection that currently exists. Based on this, chapter 4 establishes a framework and a design space for the development of new flood barrier concepts. Chapter 5 outlines the tools for capturing the knowledge that is created in the project and finally, the concepts that have been developed based on this knowledge are presented in chapter 6.

2 Literature study: Prototyping and Experimentation in Product Development

2.1 Purpose

Creating prototypes and performing experiments are essential activities when developing new products, and they can be useful tools for the duration of the development process. Because different types of prototypes and experiments are required for different stages of development, it is important to gain a thorough understanding of the various types, and how to best take advantage of them. This is the main incentive for performing a literature study on prototyping and experimentation for this master's thesis.

In an experiment investigating the benefits of various techniques in product development, Tidd & Bodley (2002) found that prototyping was useful in all projects, especially in high novelty projects, which is the category a new flood barrier concept belongs to.

2.2 What is a prototype

As a starting point, it is useful to define what a prototype is. It is common to think of a prototype as a rough version of the final product, used as a tool for validation and verification, usually late in the development. However, prototypes have proven useful throughout the whole product development process.

Houde & Hill (1997) define a prototype as “Any representation of a design idea, regardless of medium” and further argue that anything can be considered a prototype, depending only on how it is used and interacted with. For example, a brick could be considered a prototype if it represents the weight and scale of a product. This concept is similar to the ideas presented by Ulrich & Eppinger (2012) who define prototypes as “an approximation of the product along one or more dimensions of interest”; meaning that anything that exhibits properties that are of interest to the product developers can be considered a prototype, regardless of it being a physical or a non-physical object.

2.3 Classifying prototypes

The definition of a prototype established so far is extremely broad, and as different types of prototypes are useful in different scenarios and stages in the product development cycle, it is convenient to classify and categorize the prototypes. There is no universally agreed upon way to classify prototypes, but several frameworks have been proposed.

2.3.1 Ulrich and Eppinger

Ulrich & Eppinger (2012) propose a categorization in two dimensions: analytical as opposed to physical, and focused as opposed to comprehensive (see Figure 2.1).

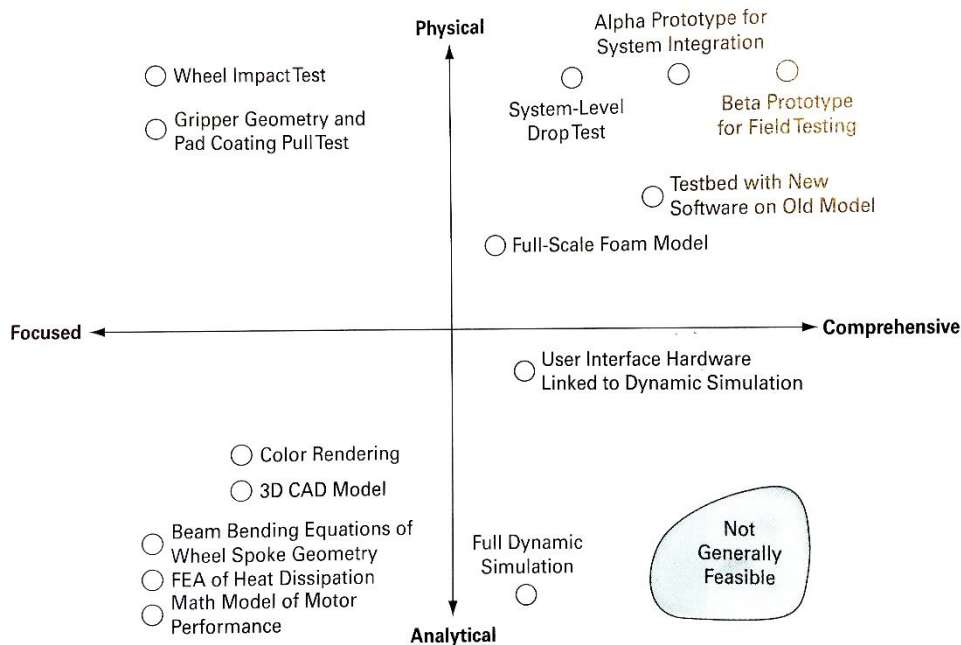

Figure 2.1: The two dimensions of Prototyping (Ulrich & Eppinger, 2012)

In physical prototypes, the aspects that are of interest to the product developer are built into tangible objects that approximate the product. An example of this notion would be the brick mentioned earlier, simulating the weight and scale of a product. Being able to interact with an object in this way, allows a product developer to get a clearer idea about the final product. A benefit with physical prototypes is that they can present the visual aspects more clearly than, for example, a 3D model on a computer screen. Physical prototypes are also useful as they often reveal aspects unrelated to the original intention of the prototype and can provide useful insight into the final product.

Analytical prototypes, on the other hand, are mathematical approximations of a product and consequently allow the parameters to be changed easily. For example, changing a specific dimension on a CAD-model could be done in seconds, while changing a dimension of a physical prototype usually requires building a new one. Therefore, for complex designs, analytical prototypes are useful to establish a range of feasible parameters, which can then later be fine-tuned by building high-fidelity physical prototypes. However, for simpler design parameters it is often advantageous to build physical prototypes directly.

Whether a prototype is considered comprehensive or focused depends on how many attributes are implemented in the prototype. A fully comprehensive prototype would therefore implement all the attributes, while a focused prototype explores only a selection. As a result, focused prototypes can be built earlier on in development, as they do not rely on every single attribute being established before building. A common practice that Ulrich & Eppinger (2012) identify is building two focused prototypes where one of the prototypes is a “looks-like” and the other a “works-like” prototype.

2.3.2 Houde and Hill

Houde & Hill (1997) categorize prototypes into three dimensions, where each dimension is an important part of the development process, and that each requires a different approach to prototyping. The three dimensions are listed below, and visualized in Figure 2.2:

- **Role:** the function an artifact serves in a user’s life
- **Look and feel:** the sensory experience of using an artifact
- **Implementation:** the techniques and components through which an artifact performs its function

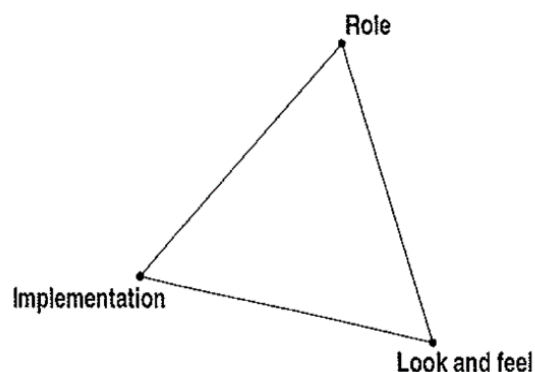

Figure 2.2 Three dimensions describing what prototypes prototype (Houde & Hill, 1997)

The purpose of this classification is to divide prototypes into categories that “visualize the focus of exploration” as each area requires a different approach to prototyping. “Role” refers to the usefulness of a product in a user’s life and requires that the context of use be established. “Look and feel” refers to the sensory aspects of using a product and requires that user experiences are simulated. “Implementation” refers to the mechanisms that allow a product to perform its functions, and it requires that a working system is built.

Houde & Hill (1997) identify a fourth type of prototype called Integration prototypes that are a combination of the three dimensions: role, look and feel, and implementation. Integration prototypes are built as a representation of the “complete user experience of an artifact” and are useful to balance and resolve constraints across the design dimensions, and to verify that the design is complete and coherent. Integration prototypes resemble a finished product the closest, but as a result often requires them to be as complex as the final product, meaning they are difficult and time-consuming to build.

2.3.3 Bryan-Kinns and Hamilton

Bryan-Kinns and Hamilton (2002) identify three dimensions that are useful for determining what kind of prototype should be used. The three dimensions are illustrated in Figure 2.3 and are:

- **Fidelity:** “The degree of exactness” of the prototype, ranging from low to high
- **Audience:** Who the prototype is intended for, ranging in terms of organizational position
- **Development stage:** Where in the development process the prototype is being used. This is not a linear process as the development process is iterative and different aspects may be relevant at different stages of development

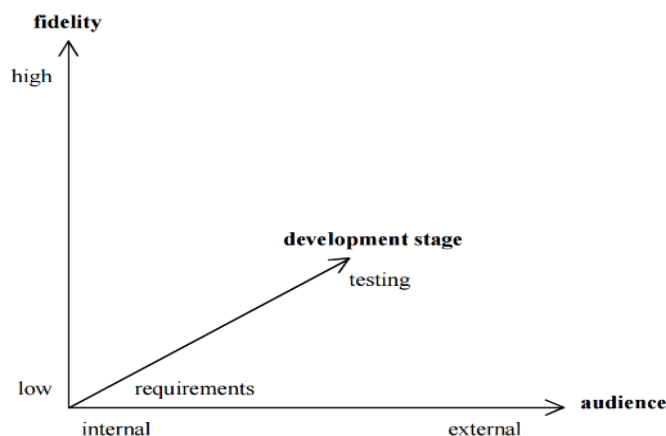

Figure 2.3 Three dimensions for determining what prototype to use (Bryan-Kinns & Hamilton, 2002)

Bryan-Kinns and Hamilton (2002) stress that although these three dimensions are the most important, they are not the only factors that should be considered when deciding what type of prototype should be made. Available tools and skills, time-constraints, and costs are examples of other dimensions that should affect the form and content of the prototypes.

2.3.4 Schrage

Schrage (1993) writes about prototyping culture and proposes a diagnostic matrix to determine how a company uses prototyping. The matrix (Figure 2.4) is composed of three axes: External vs Internal (who is going to interact with the prototype), formal vs informal (roughness of the prototype), and risk-management vs opportunity (the purpose of the prototype). Whether a prototype is classified as an opportunity or as risk management is closely related to whether or not it is designed for validation and verification, or primarily to learn and gain knowledge.

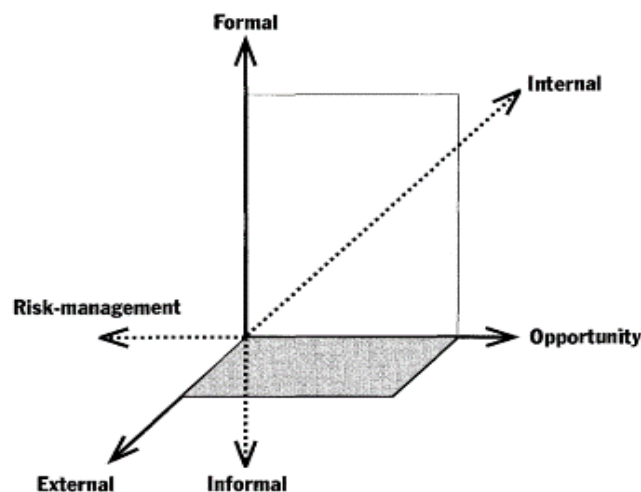

Figure 2.4 Prototype Culture Diagnostic Matrix (Schrage, 1993)

Schrage (1993) urges the use of creative prototypes, meaning informal and internal prototypes as they have the ability to create new opportunities. He argues that a company's prototyping culture can indicate its ability to innovate, and that there is a connection between the number and quality of their prototypes, and the quality of their products. The prototypes can become a tool to drive the innovation process forward, rather than simply being a product of the process itself.

2.3.5 Elverum and Welo

Elverum & Welo (2015) investigated the use of prototypes in the development of two novel innovations in the automotive industry. Their findings led to a proposed explanatory model that consists of two distinct types of prototypes: *directional* and *incremental*. *Directional* prototypes are described as a tool for evaluating the direction in which a development is heading. In this case, the prototypes are used to investigate the feasibility of a concept, and determine whether development should continue in the direction by providing “good enough” or “not good enough” as an answer. The main purpose of an incremental prototype is to optimize aspects of a product while increasing the understanding.

2.4 The purpose of prototyping

2.4.1 Ulrich and Eppinger’s four purposes of prototyping

Ulrich & Eppinger (2012) argue that within a product development project, prototypes serve four purposes: learning, communication, integration and milestones.

Learning: Is when prototypes are used to answer questions like “will it work?” and “how well does it meet customer needs?”. Prototypes in this context can reveal new aspects, opportunities or limitations that would not have been discovered otherwise.

Communication: Prototypes can aid communication in a product development process between engineers, but also with customers and management. Not only do prototypes facilitate team and firm communication, but they also offer an effective mechanism to provoke discussions early in a development process.

Integration: Prototypes can be used to encourage the different members of a team to coordinate their efforts by connecting all the parts and subassemblies that make up a product. Physical comprehensive prototypes can therefore be a highly effective tool to ensure that components work together.

Milestones: Milestone prototypes are used to show that the development of a product has progressed and that it has reached a certain level of functionality. This includes formal tests that a product must pass to achieve approval.

2.4.2 The generative role of prototypes

Lim, Stolterman, & Tenenberg (2008) point out the lack of knowledge about the fundamental nature of prototypes. The article reveals two main dimensions of prototyping: prototypes as filters, and prototypes as manifestations.

They convey that a prototype filters qualities, and consequently the designer become aware of factors of the design that generate certain qualities. This paper draws attention to the importance of the designer's ability to design prototypes that filters the qualities of interest (Figure 2.5). Further, they argue that *“the most efficient prototype is the most incomplete one that still filter the qualities of interest to the designer”*.

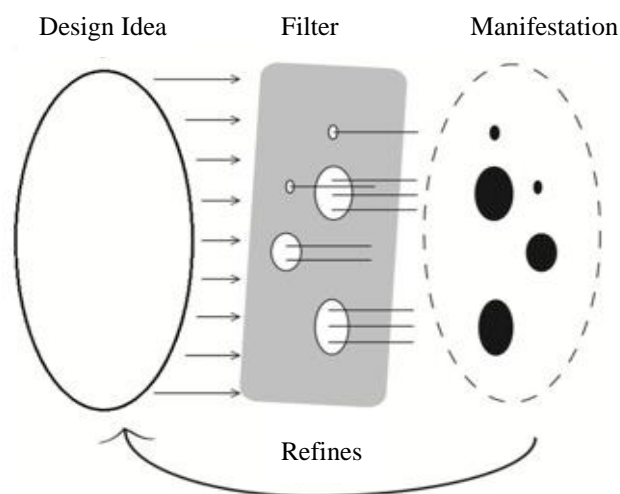

Figure 2.5 Prototyping as a filter (Lim, Stolterman, & Tenenberg, 2008)

The idea behind prototypes as manifestations is that the process of making a prototype in and of itself contributes to further development of an idea in some way.

“When a designer creates and envisions an idea, she necessarily develops the idea by moving it out in the world.” (Lim, Stolterman, & Tenenberg, 2008)

2.5 Experimentation

The term experimentation is comprehensive and hence difficult to define. Smith (2007) suggests three definitions:

- Learning by trying things out
- Something one does deliberately to see what happens
- The process of an action followed by an observation

He emphasizes that any of these three definitions points in the direction of “You provoke a situation and see how it responds”. Figure 2.6 illustrates that the learning outcome is greatest when the outcome is unexpected, and Smith states that most developers use experimentation mostly for validation and verification, meaning the learning outcome of the experiments are low.

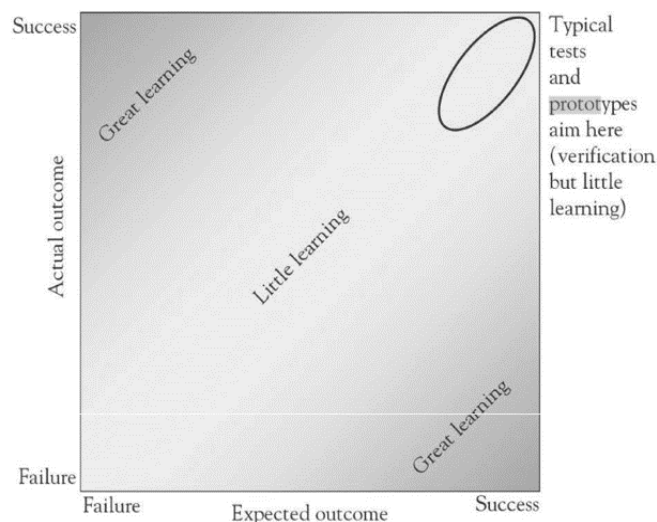

Figure 2.6 Learning outcomes (Smith, 2007)

Incorporating prototyping in the early stages of a new product development process can be a useful tool for communicating ideas and gaining knowledge. By doing this, the use of experimentation with prototypes fundamentally change, from a context where unexpected outcomes of experiments are considered non-compliance and would call for corrective actions, to a context where unexpected outcomes are not deemed as failures, but rather important means for learning and communication (Elverum & Welo, 2015).

2.5.1 Experimentation and Set-based design

Since the cost of rework increases in the later stages of development, efforts should be made early in development to avoid rework later on. However, this strategy is often difficult to enforce as development is often driven by short-term incentives, which make savings early on seem attractive. Set-based design is an attempt to prevent rework in the later stages by representing initial requirements as a range of acceptable values that are refined during development, rather than the traditional point-based method where specifications are pinned down to a single value. Development teams might often want to pin down specifications as it gives the impression that the project is moving forward, while in reality it may delay the process.

The sets established as a result of a set based approach are refined by adding constraints as additional knowledge is gained during development. This gradually reduces the design space until the final specifications are decided. Restraints can be added for many reasons, such as the laws of physics, the available technologies and laws governing production methods and materials. These restraints can be understood from the beginning of development, while other restraints become apparent as more knowledge is gained. Experimentation is a valuable method to gain this kind of knowledge to limit the design space. While the traditional method is to design and then test, the set-based approach is to test and then design based on the results.

Kennedy, Sobeck II, & Kennedy (2013) demonstrate the values of set based experimentation by exploring why the Wright brothers were successful in designing the first functioning airplane despite having considerable fewer resources in terms of aeronautical knowledge and budget than the competition. The Wright brothers identified and isolated critical knowledge gaps and then performed experiments to fill these gaps. For example, they constructed a wind tunnel to test different isolated parts of a wing design, like aspect ratio and airfoil shape, to learn how each of these parts affected lift. They would not have to take into consideration customer requirements and other airplane specifications when performing these experiments, and as a result were able to perform many tests over a short period of time to gain a lot of knowledge. They then used this acquired knowledge to design a functioning and reliable wing on their first try. Kennedy, Sobeck II, & Kennedy (2013) argue that another reason the process of the Wright brothers was so successful was because they front-loaded the development process and thereby avoiding time-consuming late-process rework.

2.5.2 Limit curves and set-based knowledge

The Wright brothers needed a way to capture the knowledge gained from the experiments in a way that enabled them to quickly and easily reuse the knowledge. To accomplish this, they created limit curves (Figure 2.7) that visualized the sets of acceptable values for given parameters in a way that was easy to understand and extract information from. These types of curves can be made for multidimensional, as well as simple 2-dimensional relationships, and they are an important tool in shifting development from a “guess and test and then rework” to a development process based on sets that are known to work.

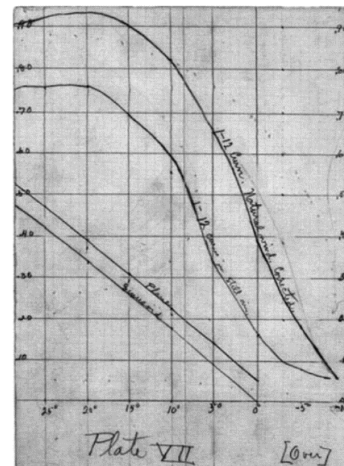

Figure 2.7 A limit curve created by the Wright Brothers

2.5.3 Experience prototyping

Buchenau & Suri (2000) discuss what they call “experience prototyping” and relate it to what Houde & Hill (1997) refer to as the “look and feel” of a prototype, but describe it as beyond “concrete sensory”. By engaging in more of an “exploring by doing” way of developing, it is easier to understand the subtle differences between design decisions and allows us to engage with new problems in novel ways. Research has been carried out studying the benefits of “learning by doing” that suggest it can lead to lower costs and increased production (Macher & Mowery, 2003).

Buchenau & Suri (2000) outline three situations where experience prototyping is especially useful:

Understanding and evaluating design ideas: Creating a high fidelity situation to simulate a user situation as a way to identify the needs and possibilities

Exploring and evaluating design ideas: Taking the ideas and creating situations that allow them to be tested by interacting with them

Communicating ideas to an audience: Allowing someone external to the prototyping process actively interact with a design idea, usually to persuade them of something

2.5.4 Collaborative prototyping

Bogers & Horst (2013) argue that by including stakeholders in the prototyping process, it changes from a process of discrete steps to a continuous process of iterative problem solving. It allows all involved with development to see their changes being implemented, while being exposed to and aware of the design constraints. As Buchenau & Suri (2000) also discussed, the prototypes act as a communication device when involving stakeholders, acting as a tool for “cross-fertilization” of knowledge, creating a balance between functionality and usability.

By creating prototypes you can involve the user and receive feedback during development. It is a lot easier for potential users to interact with a physical prototype than specifications. By introducing the users at an early stage of development the prototypes can be used as a platform for discussion to improve the product (Schrage, 1993). If the stakeholders are only introduced towards the end of development, the prototype instead becomes a tool of persuasion since it is at this point too expensive and time-consuming to go back and change the design.

It is noted, however, that there are windows of opportunity where collaborative prototyping has the optimal effect, and that efforts should be made to involve the appropriate stakeholder at the right time.

2.6 Decisions about prototyping and fidelity of prototypes.

Elverum & Welo (2015) argue that using prototypes has several limitations and shortcomings. Prototyping can be a time-consuming and expensive activity. Therefore, making the right choices about when to prototype, and choosing no more than adequate fidelity of a prototype should be a priority. High-fidelity prototypes at the wrong stages of development does not only require many resources but tends to lead to superficial feedback regarding details and appearances.

McCurdy, Connors, Pyrzak, Kanefsky, & Vera (2006) highlight that in many cases, a prototype cannot be categorized as either low or high fidelity; prototypes with different fidelity in each area should be emphasized, and is especially useful in the early parts of a development project. Focused prototypes should be designed so that the area that is to be targeted by the prototype is of higher fidelity than other parts.

“Low-fidelity methods have received a great deal of recognition in the field for their ability to validate designs and predict large problems at an extremely low cost” (McCurdy, Connors, Pyrzak, Kanefsky, & Vera, 2006)

Ulrich & Eppinger (2012) argue that the anticipated benefits in reducing risk by making a prototype, must be assessed on the basis of time and resources used to make and evaluate the prototype, especially when dealing with comprehensive prototypes. The novelty of the product should also be considered, as products are often related to new technologies, and as a result, uncertainty.

3 Understanding the Context of Floods

3.1 What causes floods

A flood is defined as “an overflow of a large amount of water beyond its normal limits, especially over what is normally dry land” (Oxford University Press, 2016), and it can be the result of many events. The most common cause is rivers or streams that overflow due to natural events like heavy rainfalls or rapid snow melting, or due to unnatural events like a dam failing. Another type of flood is coastal flooding, which occurs when the sea surges inland, usually due to a large storm or a tsunami.

Some floods take hours or even days to develop, while others are flash floods that generate quickly and with little warning. Efforts are made to predict when and where flooding will occur so that flood warnings can be issued and appropriate measures can be taken. It is the accuracy and speed of these warnings that determine the available lead-time to deploy flood protection measures.

3.2 The global impact of floods

Flooding has become the most common natural disaster in the world, and is the third most damaging (The World Bank, 2010). Furthermore, with rapid increases in urbanization, as well as aging populations in developed countries, the overall vulnerability is increasing (UNISDR, 2011). As the risk of flooding is expected to rise with increasing global temperatures (Hirabayashi, et al., 2013), the effects of climate change will further increase the risks of flood among the global population.

Even small floods can have a large impact as it is estimated that nearly 40% of small businesses in USA are unable to reopen after a small flood (Federal Emergency Management Agency, 2015). As a result, the market for flood protection systems has experienced considerable growth, and is expected to continue to increase. This is being aided by legislation and insurance discounts in some countries, and by businesses that are trying to minimize their losses.

3.3 The forms of flood protection

As a starting point, it is useful to get an overview of the types of flood protection. Ogunyoye, Stevens, & Underwood (2011) outline several ways to deal with the risk and associated problems of flooding, which include:

- **Development planning:** Avoiding development in areas prone to floods, as well as implementing SuDS (Sustainable Drainage Systems), which are management practices and facilities designed to drain surface water
- **Flood storage:** Controlling flood water by retaining and releasing it at a rate that avoids flooding
- **Channel improvements:** Increasing the flow of water so floods are unable to build up
- **Diversion channels:** Leading the water away from a certain area
- **Floodwalls/embankments:** Defense structures that prevent floodwater from getting into a protected area

The focus of this project will be on floodwalls as other types of flood protection consist and depend on large infrastructures, which is beyond the scope of this project. However, it should be noted that floodwalls can be used as diversions channels, but this will not be addressed directly.

The floodwalls can be categorized into the following three groups:

- **Temporary:** Flood protection systems consisting of fully removable parts, meaning it is erected before a flood occurs and completely removed afterwards
- **Demountable:** Flood protection systems that are at least partly pre-installed and that requires further installation to be fully operational
- **Permanent:** A completely pre-installed system that is passive, meaning it requires no further action before a flood event

The most effective type of flood protection systems is permanent flood barriers because they can incorporate cut-off barriers below ground to control underground seepage, something temporary barriers are not able to do. Furthermore, they do not rely on any operational systems, which reduces the risk of failure. However, with high costs and its obtrusive nature, it is often not a viable solution, especially for areas that are not usually affected by floods. In addition, if the requirements for a flood protection system changes, for example if protection against higher flood levels is required, the cost of changing the setup is high.

The main benefit of temporary barriers is that their flexibility allows them to be erected potentially anywhere in a short period of time. They are also relatively inexpensive, and can be stowed away when not needed. However, the main weakness of the temporary flood barriers currently on the market, is that they suffer from high seepage rates compared to the permanent systems. This is mainly due to the challenges in sealing the flood barrier against the ground as well as water seeping through permeable ground. Demountable systems can address this issue, but this comes with higher costs and less flexibility than a fully mobile flood barrier.

The focus of this project will be on temporary flood barriers, with the possibility of exploring some demountable systems. Permanent flood barriers will not be addressed any further as they are dependent on their specific location, and require research that is outside the scope of this project.

3.4 Finding an Alternative to Sandbags

Bags filled with sand and stacked on top of each other is a flood protection method that has been around for a long time, and it remains one of the most popular ways to stop floods. The popularity of sandbags stems from it being inexpensive and low-tech, requiring few tools and little experience. Empty bags can easily be sent in large quantities to areas they are needed, and with enough people and shovels (Figure 3.1), they can be filled with sand found on site to create a functioning flood barrier.



Figure 3.1 Members of the Georgia National Guard filling sandbags in preparation for floods

However, there are huge problems with the use of sandbags as flood protection. These problems include:

- Filling and stacking sandbags high enough to stop a flood is a labor intensive process
- Sand is not always readily available
- Dismantling the barrier after a flood is a labor intensive process
- Flood water is often contaminated, rendering the sandbags as hazardous waste
- UV-light degrades the bags

Despite these issues and a multitude of alternatives available on the market, sandbags are still a popular method for flood protection, meaning the high flexibility and low cost of sandbags are highly valued. Therefore, to develop a new flood protection system that can compete with sandbags, it will not only need to improve on the unfavorable aspects of sandbags, but also compete in terms of price and flexibility.

A parallel can be drawn between sandbags and mousetraps. More than 4400 patents for mousetraps exist, but despite this, the traditional spring-loaded mousetrap (Figure 3.2) invented in 1894, is still one of the most popular mousetraps in use. In the same way, there are many alternatives to sandbags on the market today without having any drastic impact on the popularity of sandbags. Consequently a new flood protection system will need to be a drastically improved system compared to sandbags in order to be able to capture a large portion of the consumer market.





Figure 3.2 The traditional spring loaded mousetrap made by Victor

3.5 Categorization of temporary flood protection systems

Table 1 identifies and describes the different types of temporary flood protection systems. Advantages and disadvantages are outlined for each.

Table 1 Categorization of temporary flood protection systems

Temporary Flood Protection Systems	
Air filled Tubes  <i>Example: NOAQ Tubwall</i>	Description: Consists of impermeable tubes filled with air. Achieves stability and a seal against the underlying surface by using a weighted skirt, or by anchoring it to the ground with pins. Advantages: <ul style="list-style-type: none">• Low storage volume• Quick installation• Easy to clean and reuse• Highly versatile Disadvantages: <ul style="list-style-type: none">• Requires a flat foundation• High width to height ratio• Vulnerable to vandalism and sharp objects• Small punctures can lead to total failure
Water filled tubes  <i>Example: Aqua Dam</i>	Description: Consists of pre-fabricated impermeable membrane tubes filled with water. Stability is achieved by the weight of the water. Typical applications are situations where longer flood protections are required, such as along roads or riverbanks. Advantages: <ul style="list-style-type: none">• Low storage volume• Quick installation• Very versatile• Less dependent on flat foundation Disadvantages: <ul style="list-style-type: none">• High width to height ratio• Vulnerable to vandalism and sharp objects• Small punctures can lead to total failure• Not suitable at low temperatures

Impermeable filled containers



Example: Floodstop

Description:

The barriers are made out of separated rigid containers filled with a fill mass like water or gravel. Because they use the weight of the fill mass for stability they are classified as gravity dams. They are most suited for urban applications.

Advantages:

- Water proof, independent of fill material
- Can be filled with any available material
- Reusable and easy to wash
- Easy to repair

Disadvantages:

- Dependent on even terrain
- Large storage volume
- Long installation time

Permeable filled containers



Example: Defense Cell

Description:

Permeable containers filled with aggregates and often strengthened by a rigid structure. Typically used in rural areas and for the protection of roads or damming along riverbanks. Sandbags fall into this category.

Advantages:

- Low storage volume
- Adapts well to uneven foundations
- Does not require skilled labor to deploy

Disadvantages:

- Labor intensive to install
 - High setup time
 - Contaminated material needs to be disposed of
 - Limited re-use
 - High seepage rates
-

Flexible freestanding barrier

Example: Rapid dam

Description:

Consists of self-supporting, freestanding sections made out of flexible and impermeable materials. Utilizes either the weight of the floodwater or anchoring to achieve stability and avoid seepage. The systems can be used in a wide variety of situations, but some systems are dependent on anchoring and therefore limit use to foundations such as grass or gravel.

Advantages:

- Quick installation
- Requires minimal labor to install
- Low storage volume
- Mobile
- Easy to clean and reuse

Disadvantages:

- High seepage at low water depths
- Vulnerable to wind prior to flood peak
- Vulnerable to vandalism and sharp objects

Rigid freestanding barrier

Example: NOAQ Boxwall

Description:

Self-stabilizing rigid barriers that utilize the weight of the flood water to achieve stability. Typically used in urban areas that call for smaller or mid-sized closed barriers.

Advantages:

- Fast installation
- Ease to clean and reuse
- Durable
- Less dependent on anchoring

Disadvantages:

- High seepage rates on uneven terrain
 - Require high storage volume
-

Rigid Frame Barriers



Example: Hydro Response Steel Barrier

Description:

Impermeable surfaces supported by rigid frame systems. These systems are very solid and are most useful in situations that call for usage over long periods of time.

Advantages:

- Very solid
- Easy to clean and reuse
- Minor repairs can be performed under while in use

Disadvantages:

- High seepage at low flood depths
 - Vulnerable to wind prior to flood peak
 - High storage volume
 - Low mobility
-

3.6 AquaFence

3.6.1 AquaFence's current system

The company's current list of products are rigid freestanding barriers that are L-shaped modules (Figure 3.3) connected together with canvas. The system takes advantage of flood water to stabilize the module and to create a seal against the underlying surface. Each module consists of two separate marine grade plywood sheets that are strengthened by aluminum frames and connected to each other with PVC canvas. Underneath each module is a thin foam gasket used as a seal between the module and the foundation. The modules can be anchored to the foundation for improved stability and reduction of seepage. The system is constructed in such a way that each module is collapsible, meaning it can fold flat and be stacked for storage.

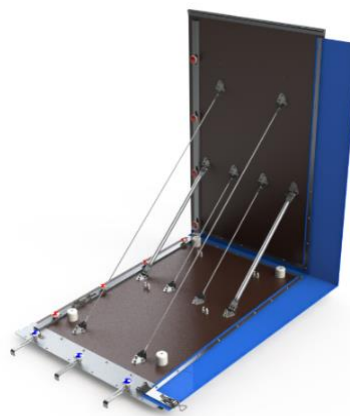

Figure 3.3 AquaFence Model V2100

The modular structure accommodates a system that can be arranged into any length and with the addition of separate corner modules, the system can be angled and create a closed system. Currently, the available system heights are: 1.2m, 1.8m, 2.1m, and 2.4m.

3.6.2 Performance test of AquaFence system

Ward D. (2012) summarizes a laboratory test carried out in 2012. The goal of the test was to gather data on the performance of the 1.2-meter-high AqF system, and comparing it to the performance of sandbags. This test is valuable to examine, as the data can be used to see which aspects the current system is better than sandbags.

The test was performed on a 1.2-meter-high and 23-meter-long AqF system which was anchored to a concrete foundation (Figure 3.4). The results were compared to a sandbag barrier that was 0.9 meters high. The results are shown in Table 2.

Table 2: Seepage and setup time for 1.2 m AquaFence barrier and Sandbags barrier

	AquaFence	Sandbags
Install/remove	Man-hours [hours]	
Construction	15.0	205.1
Repair 1	0.2	2.0
Repair 2		2.0
Repair 3		2.0
Disassembly	2.0	9.0
Depth [m]	Seepage [l/min/m]	
0.30	1.73	0.62
0.60	1.99	2.86
0.87		6.58
0.90	2.48	

**units have been converted from USC to metric*

The results clearly show that AqF's system is superior to sandbags when it comes to setup time as the man-hours required to set up the sandbags is over ten times that of the AqF barrier. The disassembly time is also much shorter for AqF's system. However, it should be noted that no information about the procedure used for setting up the sandbags is given, and that this could have an impact on the results.

In addition, AqF's system provided a superior performance compared to sandbags with regard to the seepage rates for high water depths, with the seepage rates for the sandbags being more than twice as high. However, for lower water depths (lower than 0.3 meters) the sandbags performed better. This has to do with the fact that the AqF system relies on the water pressure

on the base of the system to create a good seal against the underlying surface. When developing a new system with a focus on smaller floods, it is evident that it would need to be designed differently than the current system to improve the seepage rates at flood levels below 0.3 meters.

Overall, the AqF system performs better than the sandbag barrier despite high seepage rates at low water depths as it drastically improves as the water depth increases. However, it should be noted that the test was performed on a flat concrete foundation, with AqF's system anchored to the foundation, which is an ideal situation and may not necessarily reflect a real flooding scenario.



Figure 3.4 AquaFence installed in laboratory from (Ward D. , 2012)

3.7 The Market for a New Type of Flood Barrier

The systems that AqF currently deliver are not designed for protecting against minor floods as their smallest system is 1.2 meters high. As “a few inches of water from a flood can cause tens of thousands of dollars in damage” (Federal Emergency Management Agency, 2016) there is reason to believe there would be a market for small-scale systems. Using a system that is 1.2-meter-high is not a viable solution for protection against smaller floods due to size and cost. Each module of the system weighs about 70kg, and therefore requires a team of several people to assemble. AqF recommends a team of 10 people to assemble 100 meters of the system (Ogunyoye, Stevens, & Underwood, 2011). The cost of installing the system (in 2008) was £475/m which adds up to 100 meters of the systems costing roughly half a million GBP. Consequently, expenditure alone would exclude a significant segment of a potential market.

4 Establishing a Framework for the Development Process

4.1 Development strategy

The development strategy used in this project can be divided into four main processes:

- Initial development
- Narrowing of the design space
- Development of concepts
- Refinement of concepts

An overview of the design strategy, including key activities for each process can be viewed in Figure 4.1. Except for “the narrowing of the design space”, neither of these processes were linear and ideas and concepts were developed in parallel.

4.1.1 Overview of development strategy

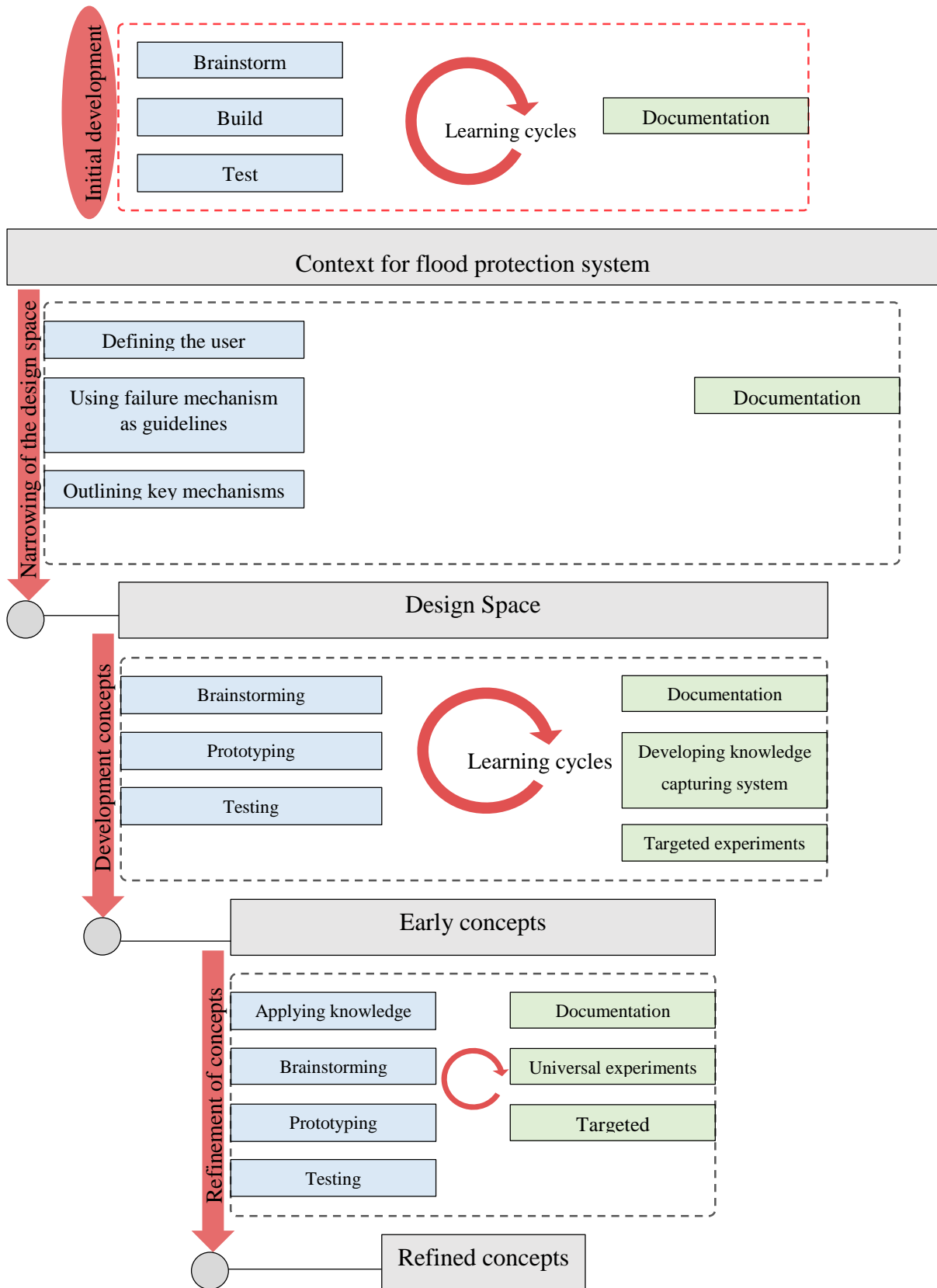

Figure 4.1: Development strategy

4.1.2 Initial development

The initial development process consisted of development before any restrictions of the design space were made. The design space was explored by quickly prototyping and testing ideas (Figure 4.3) that surfaced during brainstorming (Figure 4.2). Concepts and ideas that showed promising performance were redesigned, built and tested again. Using learning cycles in this manner is a quick way to discover the design space. Although most concepts were rejected, this approach accelerated learning by improving intuition and understanding of associated problems. Documentation from the initial development phase can be examined in *Appendix D - Documentation from initial development*.

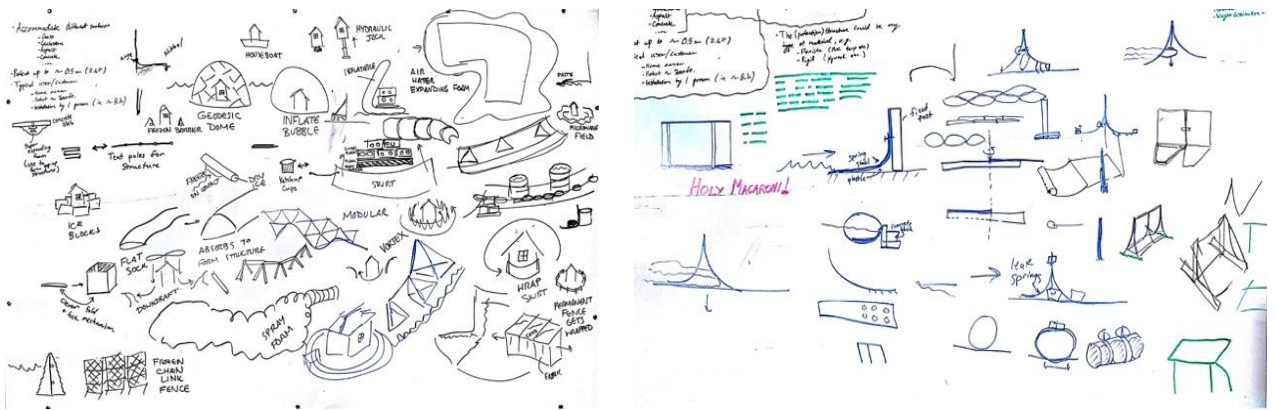

Figure 4.2: Brainstorming

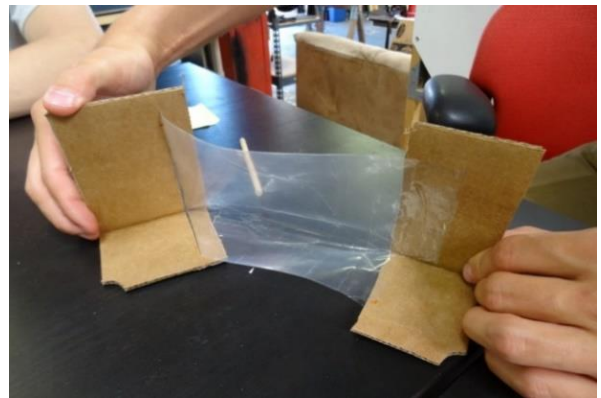
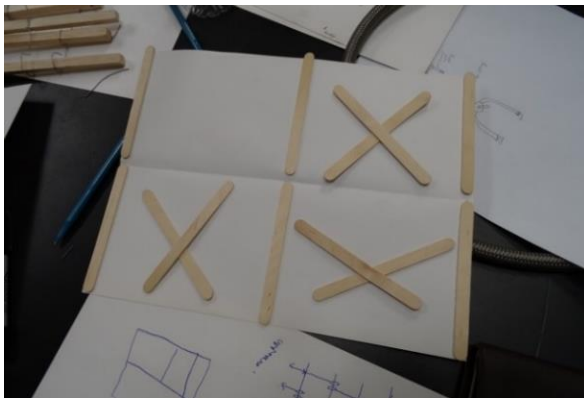

Figure 4.3: Prototyping and testing of ideas

4.2 Choosing a direction for the development

4.2.1 Defining the user

Before developing concepts for a new type of flood barrier, it is important to establish whom the new concept is being developed for. The current products developed by AqF are sold to customers who are protecting large and extremely valuable properties, such as Nestlé's mineral bottling factory in Thailand, a skyscraper in Lower Manhattan and Teterboro Airport in New Jersey. These customers are willing and able to purchase flood protection systems at a high price to be able to safeguard significant values.

This project is focused on developing a system to stop small floods for the consumer market or small businesses, where the values being protected are substantially lower compared to the customers of AqF's current products. The user that the development will be focused on is someone who owns a property in an area, which is at risk of experiencing floods. The user would purchase the system and store it somewhere on the property (or at least nearby), and erect the barrier swiftly in the event of a flood alert.

The following considerations for the user have been established:

- Does not have access to expensive tools or machinery
- Limited number of people to erect the system (maximum two)
- Highly sensitive to the price of the system
- Lives in an urban or suburban area
- Has limited storage space

4.2.2 The type of flood protection system

An understanding that a consumer flood protection system needs to be different from AqF's current products has been established. The development will therefore not focus on improving the design of the current system, but rather develop a new system from the ground up.

The different types of flood barriers (see section 3.5) were evaluated and it was decided to explore freestanding barriers further. Filled tubes were rejected because the filling material is not always available, and the high base to height ratio is an issue for most properties in an urban environment. Even though air is always available, air-filled tubes require pumps, which in return require electricity, which is not always available before a flood. Filled containers were disregarded for the same reasons, as well as for being a lot more labor-intensive to install.

There are both advantages and disadvantages for rigid and for flexible freestanding barriers. Instead of deciding which type of barrier would be most suitable for a new consumer model, the idea that a system could combine the desired features from each by creating a hybrid emerged. The desired characteristics of typical flexible and rigid systems are outlined in Table 3.

Table 3: Desired system characteristics, rigid and flexible systems

<i>Rigid</i>	<i>Flexible</i>
Stability	Flexibility
Concentration of gasket pressure	Low Weight
User perception	Mobility
Strength	Storage volume
	Set-up time
	System cost

Development will be focused on a combination of the desired characteristics from each type of system.

The main advantages of implementing canvas in a flood barrier for the consumer market is that it enables light weight concepts to be developed. The canvas increases the flexibility of the flood barrier when in use, as it can easily be bent without affecting the properties of the canvas. The flexibility also applies to storing the system as it can be rolled or folded to minimize the space required when not in use. However, the canvas needs to be supported to maintain a desired shape which needs to be taken into consideration when designing for storage.

Wear from repeated use is an issue of greater importance for canvas structures than for rigid structures due to the thickness. As floodwater often contains debris, it is susceptible to tears or punctures if debris hits the flood barrier. Even though the low weight is a desirable feature when erecting the barrier, it is less desirable when in operation. If the barrier as a whole is less dense than water, there is a risk that it will float and have no effect on stopping the flood. An increased weight leads to a higher pressure on the gasket against the ground, which affects the seepage rates positively.

Furthermore, it was decided that the system should protect against flood depths of up to 0.6 meters and that the focus would be on closed barrier systems, meaning that end connections to other structures will not be explored. End connections can be developed independently of the rest of the system and are not needed in every flood situation, and can therefore be developed at a later stage.

4.3 Failure mechanisms as design guidelines

4.3.1 Outlining the failure mechanisms and their significance

For temporary and demountable flood protection systems there are three main types of failure that can occur. These are functional failure, structural failure and operational failure (Koppe & Brinkmann, 2010). It is important to have a good understanding of each failure mechanism when designing a flood protection system so that necessary precautions can be taken to avoid them, either by knowing the limits of use, or by including certain features into the system that prevent certain types of failure. It does not mean that the failure mechanisms should have a large impact on early phase concepts, as they can often be addressed in later stages of development, but the knowledge may however prevent expensive rework in the later stages of development.

Table 4: failure modes

Failures of temporary and demountable flood barriers	
<i>Functional failure:</i>	Overtopping of flood barrier or excessive seepage through protection system
<i>Structural failure:</i>	Insufficient strength or stability
<i>Operational failure:</i>	Failure of closure of flood barrier

The different failure modes are explained in the next sections, and the mechanisms that affect the failure modes are explored in section 4.4.

4.3.2 Functional failure

This type of failure is based on pre-determined performances of the system that are not met. If, for example, a system is designed and specified to a given maximum amount of seepage and this is exceeded, it is considered a functional failure.

This failure mechanism is avoided by gaining a proper understanding of the environment the flood protection system is operating in which demands appropriate hydrological and hydraulic analyses, topographical surveys and an understanding of the seepage characteristics of the surface the system is deployed. It is not possible to know exactly what environment the barrier will be deployed in, but it is important to understand which parameters affect the seepage rates.

4.3.3 Structural failure

This type of failure occurs as a result of insufficient strength or stability. This can lead to breaching, collapse, overturning, or sliding, and failure is defined as the point at which the system is no longer able to meet its predefined performance.

Two main factors make structural failure more likely to occur in temporary flood barriers compared to other forms of flood protection. The first is that mobile systems usually consist of many parts and subcomponents, and a failure in one of these parts can often lead to a failure of the system as a whole. The second factor is that mobile systems are usually not designed for one particular place and usage, making it difficult to predict performance. Conditions could further aggravate if the system is needed on short notice with insufficient time for detailed study of the location and environment.

4.3.4 Operational failure

Operational failure is defined as a failure to fully erect the system before the flood reaches a critical height, which is the height at which it is too late to set up a functional system. This can either mean that the system was not closed off in time or not erected correctly. The risk of operational failure will often be increased in temporary systems as they often need to be mounted in dark or stormy conditions. This can be the result of very short lead-times before expected arrival of a flood.

The four processes that are involved when installing a temporary flood barrier are forecast, alert, mobilization and closure. If either one of these fail, the whole system fails. By improving each of these stages when installing the flood barrier, the risk of operational failure is reduced. Forecasting and alerting are independent of the system, but it is however possible to affect the mobilization time and closure time through design choices.

4.4 Outlining the Key mechanisms

4.4.1 Structural strength

There is a considerable number of forces that are involved in a flood. In addition to the hydrostatic pressure, there are forces from waves, currents, wind and impact from debris floating in the water. The flood barrier as a whole needs to withstand all of these forces, meaning that every component and sub-component also needs to take these forces into consideration. It is not necessary to do detailed calculations and simulations early on in the development process, but decisions about design should account for the possibility of needing to change dimensions, material selection or other properties in order to strengthen the component if necessary.

4.4.2 Stability

In addition to having the structural integrity to withstand the forces exerted by the water, the system is required to have sufficient stability to avoid the two structural failure mechanisms: sliding and overturning (Figure 4.4). Sliding takes place when the friction at the tipping point is too low, and overturning occurs when the friction at the tipping point is too high.

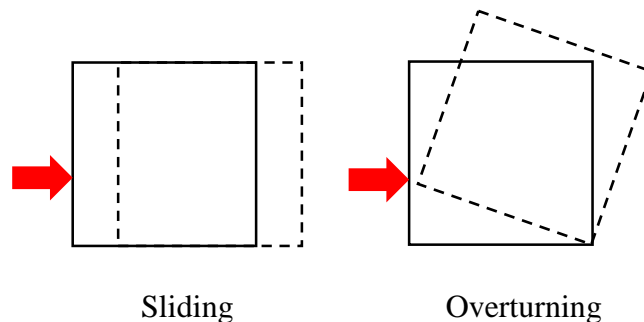

Figure 4.4 Sliding and overturning

The stability of a module can be deconstructed into the forces acting on the base of the module, and the forces acting on the wall of the module. The higher the forces are on the base compared to the wall, the more stable the system is. Mechanisms for achieving this are outlined in Table 5.

Table 5 Mechanisms to increase the stability of a system

Mechanism	Comments
Increasing the base area	A simple solution that can be integrated into most systems. However, this increases the width to height ratio, which means it requires more space when in operation, limiting the places where it can be erected.
Increasing the weight	Increases the stability, but makes the system harder to assemble for a small group of people. Can also increase the cost of the system as it requires more material.
Adding external weights	Useful when extra weight can be found on site, which is not always the case.
Anchoring to the ground	A lightweight solution that can increase stability considerably. However, there are a limited amount of surfaces that allow quick and simple anchoring. For example, anchoring to asphalt is possible, but requires expensive tools.

4.4.3 Creating a seal against the underlying surface

One of the major challenges involved with temporary flood barriers is creating a proper seal against the ground. To create the seal, rigid systems tend to use a gasket mounted underneath the base, towards the front, while flexible systems tend to use a long skirt constructed of the system material.

It was established that the sealing properties of a temporary flood protection system depends on a series of variables that can be divided into two groups: circumstantial and system design. The variables are outlined in Table 6.

Table 6 Seepage variables

Circumstantial	System design
Foundation material	Gasket material
Water pressure (flood depth)	Gasket dimensions (width and height)
Seepage through foundation	Pressure in gasket

The gasket material is best evaluated through testing as there are many options, each with different properties. The dimensions of the gasket can affect the seepage rate as the narrower the width is, the higher the resultant pressure on the gasket becomes, which in turn reduces the seepage rates. The pressure on the seal can also be increased by increasing the force on the base of the module, and can be affected by the same mechanisms as discussed in Table 5.

In freestanding barriers, the weight of the water is usually the most significant contributor to the pressure on the gasket, which in return improves the sealing against the underlying surface. This means that seepage rates are often very high at low water depths, which was made clear during testing of AquaFence’s system outlined in section 3.6.1. This means that the force on the base affects the seepage rates, but the seepage rates also influence the force on the base. This is due to the fact that the stability that comes from the weight of the water, is dependent on a pressure difference over and under the base of the module. If the seepage rate is high, there is a lot of water underneath the base which can counteract out the hydrostatic forces, and consequently reduce the stability of the system. Creating a good seal is therefore extremely important, especially at low water depths.

4.4.4 Flexibility

Since consumer flood protection systems should accommodate installation at various locations with little or no modification, the system should be as flexible as possible. In this context flexibility means that the system can adapt to uneven foundations as well as having the ability to follow the terrain through bends, or go around corners. In Figure 4.5, the different modes of flexibility between two modules are illustrated. The different modes of flexibility are translations along each axis, and rotation around each axis. Increasing flexibility of each mode corresponds to an increase in complexity for the system, so only the most important ones should be addressed. Each mode of flexibility is therefore explained in detail in Table 7.

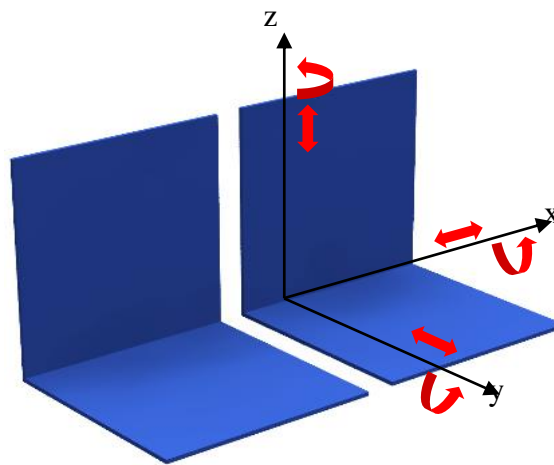

Figure 4.5 Different types of flexibility

Table 7 Evaluating the importance of each degree of freedom

Mode	Importance	Extent	Achieved characteristics
Translati on x-axis	high	low	Affects “wobble room” in the space between the modules. Allows the barrier to be closed without planning out the position of each individual module beforehand.
Rotation x-axis	moderate	moderate	Allows adjacent modules to be placed at different angled foundations, while maintaining sealing capabilities.
Translati on y-axis	low	moderate	Allows adjacent modules to be placed with a distance between them, which can be an advantage in case of obstacles.
Rotation y-axis	high	high	Allows adjacent modules to be placed at different angled foundations, while maintaining sealing abilities.
Translati on z-axis	moderate	moderate	Allows adjacent module to be placed at foundations with different heights
Rotation z-axis	high	high	Allows a module to be placed at an angle to the adjacent module

Rotation around the z-axis and the y-axis have been identified as the most critical modes of flexibility and needs to be addressed in the development of new concepts. If the maximum rotation around the z-axis is large enough it is possible to create an enclosed system using only one type of barrier. AquaFence’s current lineup allows for some rotation, but is dependent on additional corner modules like the one seen in Figure 4.6. Being able to avoid the use of extra modules can help drive the cost of the system down, as well as allowing for more flexibility when erecting the system.



Figure 4.6 AquaFence V1200 outside Corner

4.5 Other considerations for development

4.5.1 User perception

When developing products for the consumer market, it is not enough to create a great product. It is equally important to convince the customer that the product is good, and it is not necessarily sufficient to back up a concept with numbers. The appearance of the product is a useful tool in convincing the customer that the flood barrier is stable and secure, and that it can protect their property. This can for example be done through material selection, as solid beams would portray higher strength than a cable would, even though tensile strength could be equal.

Canvas has the advantage of being extremely lightweight and flexible compared to a rigid plate. These advantages must however be weighed up against the perceived effectiveness of the system, as canvas may be perceived as “flimsy”. Using canvas therefore demands extra attention to the need of portraying security to the user.

4.5.2 Ease of use

AquaFence's current systems are designed for large applications, and require trained personnel to ensure correct mounting. Since the new system is being targeted at consumers it means that the system will be mounted without training. This means that the system will need to be designed in a way that helps reduce the risk of operational failure. Steps that are likely to be performed incorrectly for a concept should be identified and addressed accordingly.

By providing feedback to the user when mounting the system, the user can be assured that the system is correctly mounted. Examples of feedback can be "torque-control" when tightening bolts or the use of symbols to indicate which parts interconnect.

Improving the user-friendliness by making the system as simple as possible to set up can, assure the user that the system is mounted correctly and will thereby increase the trust in the system. However, this should not affect the effectiveness of the system in use. Making the system as simple as possible would be beneficial in reducing the time needed to fully erect the system, and limiting the likelihood of operational failure.

4.5.3 Production

As the flood barrier being developed is aimed at the consumer market, reducing the cost of the system is critical. Since production cost is a large part of the total cost, efforts should be made early on to come up with design decisions that allow for cheaper production methods. This can be done, by among other things, reducing the number of components needed for each module, simplifying the geometries, using inexpensive materials and focusing on effective use of materials. Some aspects, like material selection, can only be made later on in development, while other aspects, like reducing the number of components, can be done early on.

4.5.4 Storage and Transportation

As one of the main advantages of temporary flood barriers is that they can be stowed away when not needed, it is important to design a system that allows it to be stored an effective way, and be transported in an effective way to where it is going to be set up. AquaFence solves this by having modules with hinges, so that they can be folded into a flat shape and be stacked. Another way to make storage and transportation easier with L-shaped modules is by making them stackable (Figure 4.7) without having to fold the modules first. Stacking like this does not require hinges or other extra parts and is therefore a good option when making simple modules.



Figure 4.7 A stack of NOAQ-Boxwall modules

Another concern that needs to be addressed when storing and transporting a system, is the ability to clean it properly subsequent to use. Floods are often contaminated by sewage and other waste, and thus the modules need to be designed in a way that allows proper cleaning after use. Complex or hidden geometry should therefore be avoided in order to allow for easy cleaning.

4.6 Summary of design restrictions

Table 8: summary of design restrictions

Quantitatively	Qualitative
Protect against 0 m to 0.6 m flood depths	Low cost system
Freestanding barrier	Compact when not in use
Maximum two people required for installation	High flexibility
No advanced tools or machinery required	Fast installation
Closed barrier	Build user trust/confidence
Hybrid of rigid and flexible system	Avoid operational failure
	Avoid structural failure
	Avoid functional failure

5 Gaining and Capturing Knowledge

5.1 The value of capturing knowledge

There are two main reasons why capturing the knowledge is useful. Firstly, the development process is often long, and if the knowledge acquired early on is not captured, it is likely forgotten later when it may be useful. This means that the time spent gaining the knowledge was wasted and that value was later lost. The second reason for capturing knowledge is to avoid expensive rework. Processes are often repeated several times during development, and if relevant knowledge is lost between each time, unnecessary rework is needed.

For flood barriers, there are several aspects that apply to any system. For example, as almost all systems on the market today implement a gasket, it is reasonable to expect that the new system also will implement a gasket. Therefore, instead of redoing work about gaskets for each concept that is being developed, knowledge about gaskets should be captured in a general way that allows it to be applied to any system. This was the reason for performing the gasket experiments, which is discussed further in section 5.4.

Another situation where it is valuable to be able to reuse knowledge is when choosing the dimensions for certain concepts, as there are multiple variables that make up a virtually unlimited number of combinations. It is not feasible to evaluate every combination individually, but by establishing the general relationship between each property of the flood barrier, it is possible to quickly evaluate the parameters without having to repeat the same process over and over.

Several methods for capturing knowledge were used for this project. After brainstorming sessions, a document would be created which quickly outlined what had been discussed and which conclusions had been drawn, and photos would be taken off the whiteboard if this had been used during the brainstorm. Building prototypes and performing experiments is another useful tool used during this project as a way to both create and to capture knowledge (discussed in Section 2). Also, a program for capturing knowledge was developed based on Knowledge Based Engineering (KBE), as the main objective with KBE is to be able to capture engineering expertise and to be able to present this to the engineer in an effective way when it is needed (discussed in Section 5.2).

5.2 Developing a Knowledge Capturing System

5.2.1 The requirements

For a knowledge capturing system to be a useful tool in the development process, several qualities the system needs to fulfill were outlined. These were as follows:

- The ability to apply the system to new flood barrier concepts
- Easy to customize the inputs and outputs of the system
- Present knowledge in a clear manner that is easily interpreted by a person
- Provide information that can be used for evaluating new concepts

As creating a program is a time-consuming process, it is important to make sure that the net gain is positive. To ensure this, the program needs to be easily applied to any new flood barrier concept to avoid creating a new program each time. Also, by being able to apply the program to different concepts, it can be used to easily compare different concepts against each other.

As knowledge is gained and relationships between parameters are established, there needs to be a simple way to implement this into the system. Also, new aspects that are of interest are likely to arise during the development process so new parameters need to be simple to add or change.

Being able to present the knowledge in a way that is useful means that it needs to be presented clearly, not only for the person who created the program. For the program to be useful to the development team, anyone who uses the program should be able to understand how to use it, and what is being presented.

Lastly, it is important that the program provides information that can be used in the development of new concepts. This can be, for example, to evaluate and optimize parameters, identify gaps in knowledge that needs to be filled or comparing concepts to each other.

5.2.2 Developing the program

The program was created using Microsoft Excel using 'Visual Basic Editor'. Microsoft Excel was chosen because it is a powerful application that is familiar to almost everyone, allowing the Knowledge Capturing System to implement a user-interface people already know how to use. Also, because most people have access to Microsoft Excel, it means that the system can be

used without requiring users to purchase and install new software. Another advantage is that it is easy to export data from Microsoft Excel to other applications.

The code for the program is included in *Appendix A – Code for the Knowledge Capturing System*.

The main function of the program is to calculate properties of new flood protection concepts based on inputs from the user, and then present it in a useful way. It was therefore decided to divide the program into the following six areas:

1. **Controls**
2. **Constants** (Input)
3. **Variables** (Input).
4. **Output** (Output)
5. **Graphs** (Output)
6. **Data points** (Output)

A Controls area (Figure 5.1) was established to let the user select the information that they wish to display. The user can select which parameters will be plotted using drop down menus. The program can be updated and reset using the “Update” and “Clear” buttons.

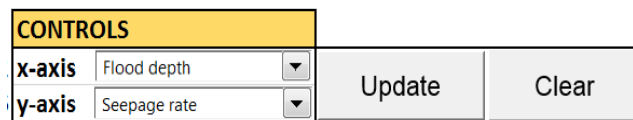

Figure 5.1: The Controls area

Input was divided into the two areas: Constants and Variables. This was done in order to clearly separate the values that can be affected by design (like the dimensions) and those that cannot (like gravity and the density of water). The user can input a range for the parameters in the Variables area by inserting the lower limit into the “Value (0)” column and the upper limit into the “Value (n)” column.

Output was divided into the three areas: Output, Graph and Data Points, where each area presents the information in a different way. The Output area shows the values that have been calculated for each property based on the values from the input areas. This is useful when values of properties of specific configurations are of interest. The Graph area acts as a visual representation, which is useful to see how changing one parameter affects and for identifying critical points. Also, because it allows multiple graphs to be drawn on top of each other, it is a

useful tool for quickly comparing two or more situations against each other. The Data point area is useful for looking closer at specific points of the graph, or for exporting the data to another program.

The program was created in a such a way that customization is made easy by allowing the user to insert new rows to any of the three tables without needing to worry about the programming (Figure 5.2). This was done by the program “reading” where each table starts and where each ends so that each table is treated correctly when performing the calculations. The relationships can be added in column B of the output area in the same way that functions are added to cells in Microsoft excel. To use values from any of the other areas, the cells in column B are used. The different formulas in column B are included in *Appendix B - Equations used to establish relationships for Tetris*.

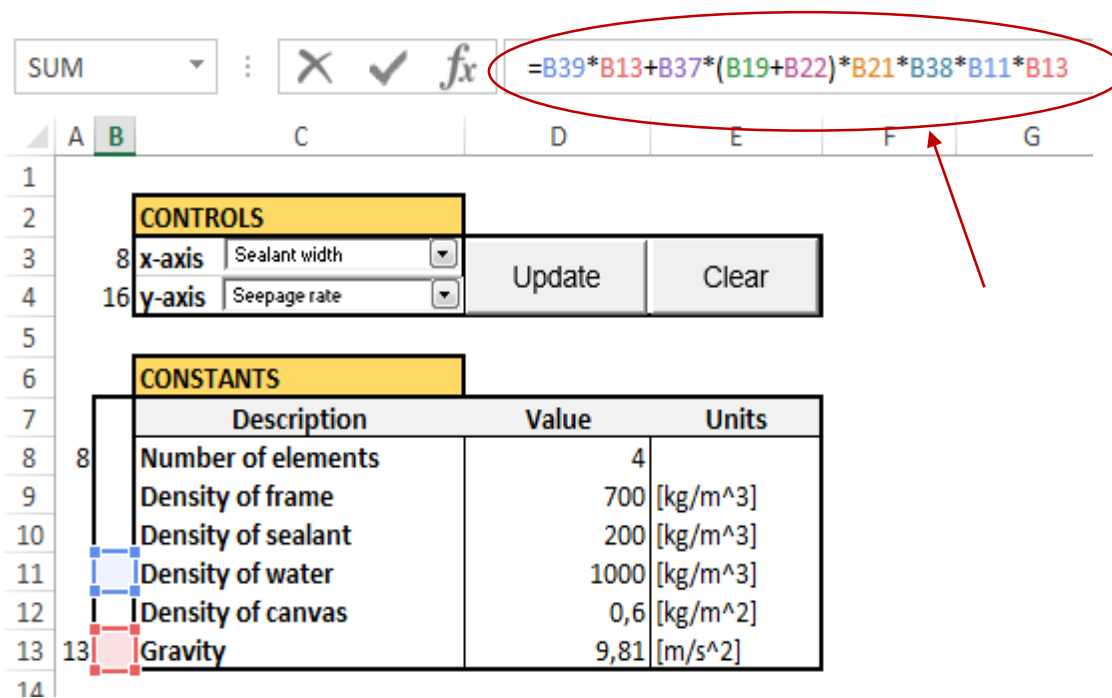

Figure 5.2 Screenshot illustrating how relationships between parameters are added

5.2.3 How to use the system

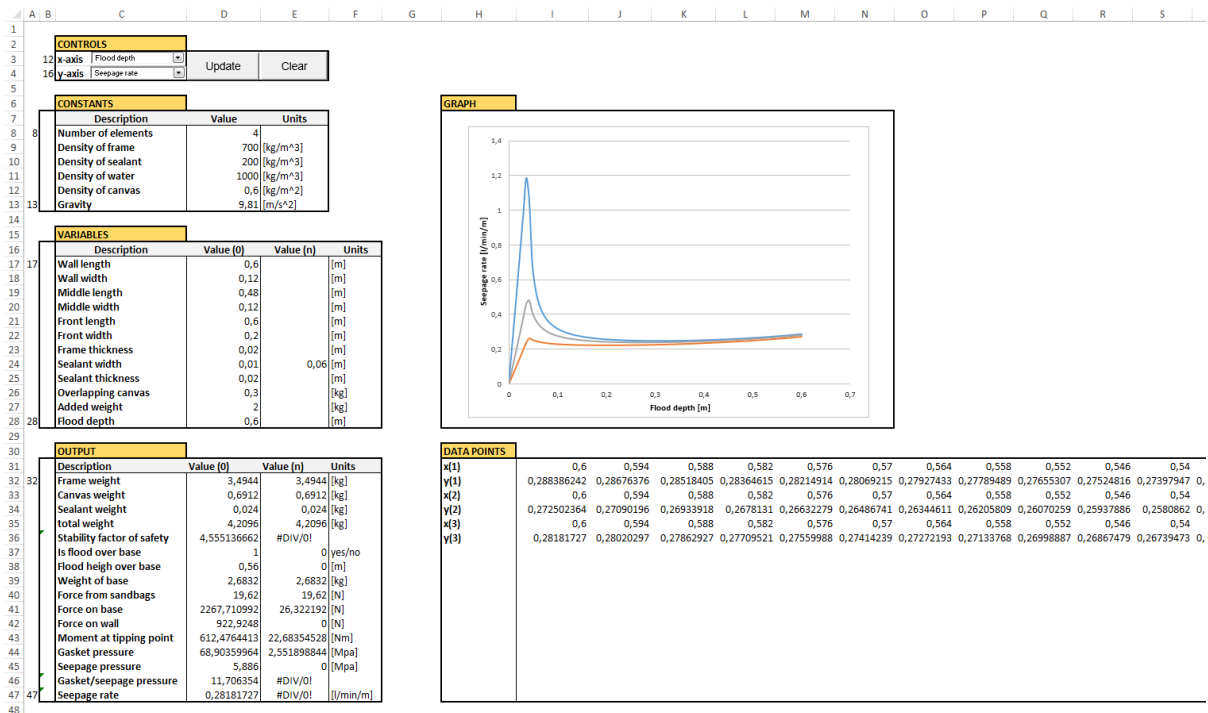

Figure 5.3: User interface

The program (Figure 5.3) is used in the following way:

1. Choose the relationship that is going to be explored by selecting the x-axis and the y-axis parameters in the drop down menu
2. Fill in the values in the “Constants” table
3. Fill in the values in the “Value (0)” column in the “Variables” table
4. Fill in the values in the “Value (n)” column in the “Variables” table. This is only for the parameters that span a range, for example see how the stability of a system changes as the flood depth increases from one level to another, and is otherwise left blank
5. Press the “update” button to calculate the values in the “Output” table and to plot the graph. The values in the “Value (0)” and the “Value (n)” column of the “Output” table corresponds to the values in the columns of the same names in the “Input” table
6. Steps 2-5 can be repeated to compare different plots on the same graph
7. Press the “clear” button to reset the program. This clears the graph and the values in the “Variables” and “Output” table.

5.2.4 Establishing the relationships

Changing the parameters of a design will often have an effect on multiple aspects of a design. For example, increasing the thickness of a structure will increase the weight and cost while also affecting the structural properties like stiffness and strength. Some of the relationships are

clearly defined, like the effect the flood depth will have on water pressure where the two are linked by the formula for hydrostatic pressure ($P=\rho gh$). Other relationships are more complicated, like how seepage rates are affected by the gasket material. In these cases it is easier to establish the relationships through experimental testing.

When performing experiments to establish relationships it is important that the knowledge created is reusable. By breaking down the product into subsystems and isolating each subsystem for testing, the results can be applied to many concepts. Two subsystems were identified that apply to the type of barriers that are going to be developed that require experiments to establish:

- Contribution of canvas towards stability (Explored further in section 5.3)
- Seepage rates for different gaskets (Explored further in section 5.4)

5.2.5 Limitations

The program is meant as a quick way to evaluate the different concepts during the development process and is not meant as a way to certify different systems as the relationships established are only approximations. There is also the possibility that some relationships are defined incorrectly, so further testing should be conducted to verify the relationships.

5.3 Investigating the contribution of canvas towards stability

5.3.1 Loss of stability and gasket pressure when using canvas

Using canvas does introduce some complications regarding the stability and sealing of a system. When the canvas rests against the foundation the hydrostatic pressure transfers to the ground rather than supporting the structure. The area of the canvas in contact with the ground will not contribute to stability or gasket pressure, (see Figure 5.4).

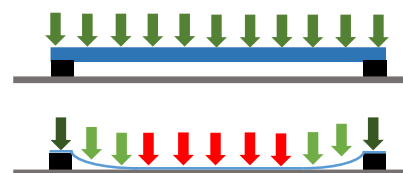

Figure 5.4 Rigid plate vs canvas

Therefore, the stability of the system increases as the canvas is elevated from the foundation. This can be done by tightening the canvas, raising the attachment points or distributing the rigid area (see Figure 5.5).

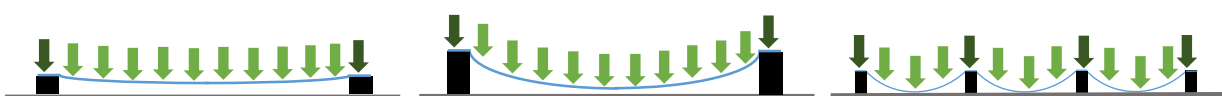

Figure 5.5 Ways to increase contribution from canvas towards stability of a module

5.3.2 Designing the experiment

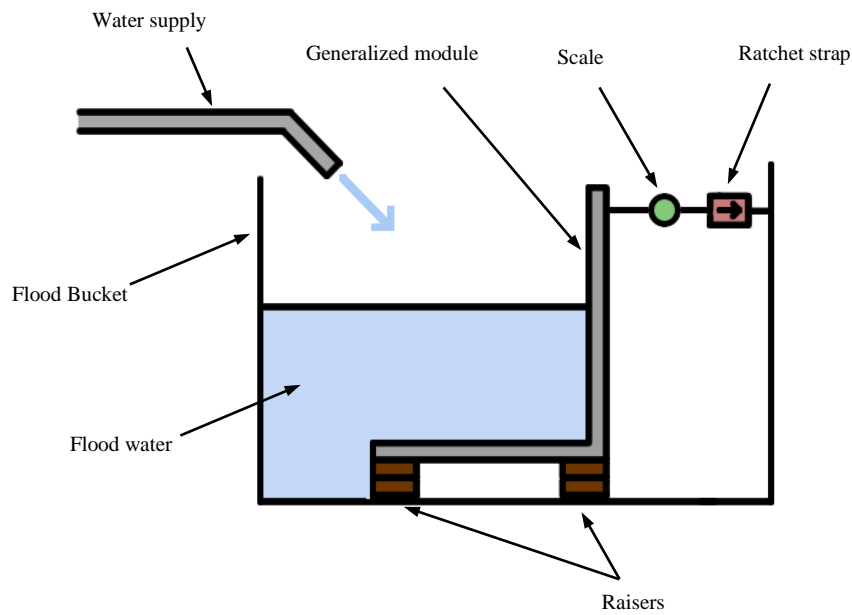

Figure 5.6 Diagram of the test setup

Defining the area of canvas resting on the ground is dependent on multiple variables which are difficult to define as the canvas is not a rigid material. Initially, a conservative assumption was made that there was no contribution from the canvas at all, meaning that stability is only achieved through the rigid components of the barrier. To gain a better understanding of how the canvas contributes to stability, a test setup was designed (Figure 5.6).

The setup consists of a generalized freestanding module (Figure 5.7) that is mounted in a flood bucket. A ratchet strap is attached to the top of the module that can be tightened to increase the force until the front of the module is lifted. The force applied is measured with a digital scale that is attached between the module and the ratchet, and based on the magnitude of this force it is possible to estimate the contribution of the canvas towards the stability by performing a moment calculation around the tipping point.

Raisers were added to the module to test how lifting the canvas affects stability.



Figure 5.7 The generalized

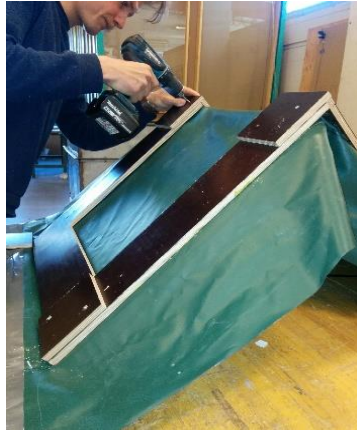

Figure 5.8 Backside of base, attachment of raisers in progress



Figure 5.9 Module rigged in test tank

The following test procedure was performed:

1. Add raisers to the base of the module (see Figure 5.8)
2. Mount the module in the test tank (see Figure 5.9)
3. Attach the ratchet strap to the module
4. Fill the test tank with water up to the desired water level
5. Zero the scale
6. Tighten the ratchet strap until the front of the module starts to lift
7. Record the force displayed on the scale
8. Repeat steps 4-6 three times for more accurate measurement
9. Repeat steps 1-8 for each canvas attachment height

5.3.3 Results

All of the canvas was above the foundation when the attachment height was 24 mm (only one layer of raisers), so the experiment was only performed for two canvas attachment heights. Because the hydrostatic forces on the rigid parts of the modules are simple to calculate, the contribution was calculated by finding the sum of moments around the tipping point. The results are presented in Table 9.

Table 9 Results

Results			
Attachment height [m]	Water depth [m]	Ratchet Force [N]	Canvas Contribution [Nm]
0,012	0.05	11.8	23.8
	0.10	109.3	45.1
	0.15	200.9	71.8
	0.20	299.0	99.3
0,024	0.05	394.4	33.1
	0.10	11.8	60.6
	0.15	122.6	94.4

Since the canvas was completely lifted at an attachment height of 24 mm, the canvas contribution is 100% of a rigid plate of the same area, and at 12 mm, the contribution is roughly 75%. From this, the first conclusion that can be drawn is that canvas contributes considerably to stability, even when the attachment point is relatively low. This was unexpected, especially since the canvas was not attached particularly tight. This indicates that the use of canvas in freestanding consumer flood protection systems may be a viable solution.

The outcome of the experiment shows a noticeable increase in the moment contribution as a result of an increase in canvas height. This supports the idea of lifting the attachment point as a way to increase stability on modules consisting of canvas.

5.3.4 Limitations

This was a quick experiment set up to learn more about whether freestanding modules that incorporate canvas can depend on stability by more than just the rigid sections. The measured values and calculations are indicative as there are factors that may affect the results that were not controlled for. The results are not meant to be used to determine properties of a system accurately. However, later on in development when promising concepts have been created and need to be refined, a modified version of this experiment would be useful. It could be used to determine the exact contribution from the canvas and the overall stability of various configurations.

5.4 Investigating the seepage rates for different gaskets

5.4.1 Establishing the variables

Most systems incorporate a gasket in their design to prevent water from seeping underneath the barrier. It is therefore useful to gain an understanding of how a gasket performs in a given flood situation, and how to obtain the best seal. Instead of performing tests on each new flood barrier concept that developed, the gasket can be isolated as a subsystem. The results from the experiments that are performed can then be applied to new concepts without further testing.

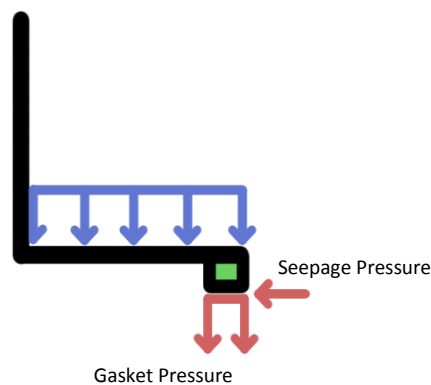

Figure 5.10 Gasket pressure and seepage pressure

As the seepage rate is the most relevant aspect of a gasket it is important to understand which variables affect the seepage rate, so that they can be controlled accordingly. An hypothesis has been established maintaining that the main variables that affect the seepage rate is the “Gasket pressure” and the “Seepage pressure”. The Gasket pressure is defined as the combination of forces acting over the area of the gasket against the underlying surface. The main forces contributing to the gasket pressure are the water pressure (determined by the depth of the flood water), the weight of the module, and any additional weight placed on top of the barrier. The seepage pressure is defined as the hydrostatic pressure at the gasket that causes seepage as opposed to the pressure of the water that has seeped through. This is illustrated in Figure 5.10.

These are therefore the two independent variables that can be changed (gasket pressure and seepage pressure) to affect the dependent variable: seepage rate. A gasket experiment will therefore need to allow these two independent variables to be changed, while at the same time measuring the seepage rate.

5.4.2 Designing the experiment

This experiment was designed as a quick way to quantify the relationship between the seepage rate, the gasket pressure, and the seepage pressure for gaskets on different ground surfaces. Furthermore, it was designed in such a way that the information learned could be used for any type of flood barrier that uses a gasket.

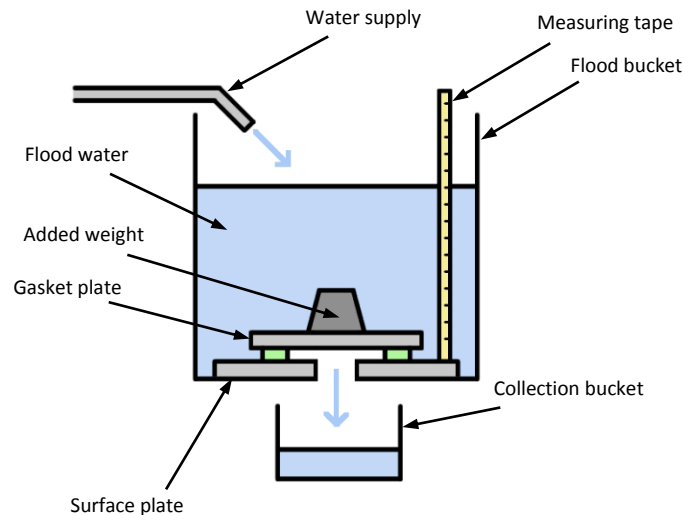

Figure 5.11 Diagram of the test-setup

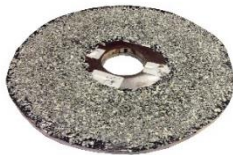

Figure 5.12 Top and bottom of the surface plate

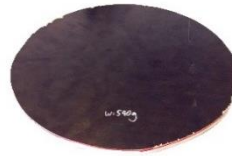

Figure 5.13 Top and bottom of the gasket plate



The setup (Figure 5.11) consists of a container, called the flood bucket, which is filled up with water to simulate a flood of a certain depth. In the bottom of the flood bucket is a hole that is covered by the gasket plate. The gasket plate is a solid plate that has the gasket being tested attached around the perimeter of its base (Figure 5.13) so that the water that comes out of the hole in the bottom of the flood bucket is the seepage rate for that gasket. The seepage pressure is controlled by varying the depth of the water in the flood bucket, using the measuring tape attached to the side of the flood bucket as a guide. The gasket pressure is controlled by a combination of the flood depth and added weight placed on top of the gasket plate.

Because flood barriers are deployed on different types of surfaces, it is useful to be able to perform the experiment for different surfaces without having to build a new test setup for each

surface. A plate called the surface plate (Figure 5.12) that can easily be mounted and demounted is therefore added between the base of the flood bucket and the gasket plate (see Figure 5.14). It has a hole in the middle for seepage and is sealed around the edges to make sure that the only water that comes out the bottom of the flood bucket comes from the seepage between the gasket and the surface plate.

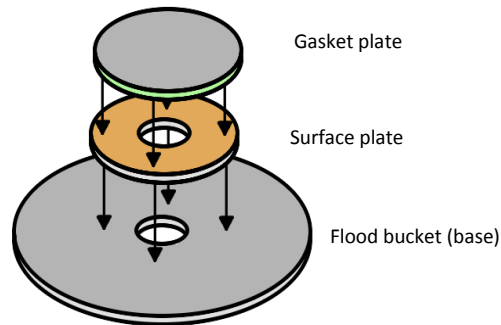

Figure 5.14 Configuration of gasket plate and surface plate

The seepage water is collected in a container, called the collection bucket. The collection bucket is placed underneath the outlet for a set amount of time, after which the amount of water in the collection bucket is measured to calculate the seepage rate (see Figure 5.15).

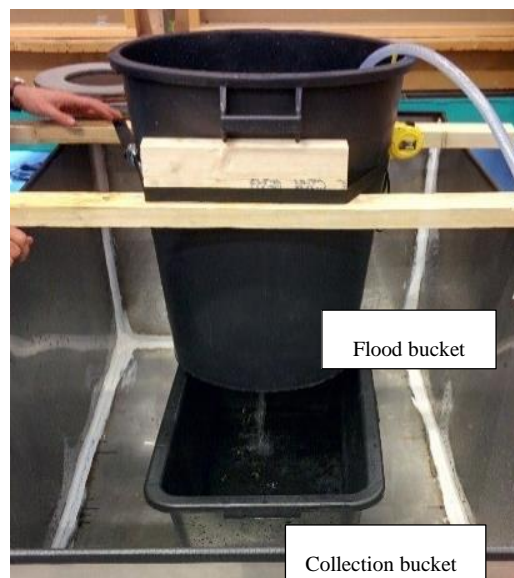

Figure 5.15 Experiment setup

5.4.3 Test Method

- 1) The test setup was prepared by attaching the surface plate to the flood bucket, assuring that seepage only occurs through the center hole, and not between the seal plate gasket and the flood bucket. This was done by taping the hole with a strong water-proof tape and filling the flood bucket with water. As no seepage occurred, the surface plate was attached correctly.
- 2) The gasket plate was placed over the hole in the surface plate and the desired amount of weight was placed on top of the gasket plate.
- 3) The flood bucket was filled with water from the water source until the water depth was at the desired level.
- 4) The collection bucket was placed under the flood bucket to begin the experiment. The flood bucket was refilled during the experiment to compensate for the seepage, using the measuring tape as help to maintain a constant flood depth.
- 5) After 2 minutes, the collection bucket was removed from underneath the flood bucket to stop recording seepage.
- 6) The amount of water in the collection bucket was measured by weighing the bucket.
- 7) Steps 2-6 was repeated for the different flood depths.
- 8) The gasket plate was changed and steps 2-7 were repeated for each gasket plate.

5.4.4 Data collection

The four gaskets tested were all made from the same foam material, but with different thicknesses (0.8 cm and 1.8 cm) and widths (3 cm and 6 cm) and an outer diameter of 30 cm.

The gaskets were:

- Narrow (3 cm) and Thin (0.8 mm)
- Narrow (3 cm) and Thick (1.8 mm)
- Wide (6 cm) and Thin (0.8 mm)
- Wide (6 cm) and Thick (1.8 mm)

The gaskets were tested at flood depths of 0.1 m increments up to 0.6 m, with additional measurements at 0.05 m and 0.15 m due to large variations at low flood depths.

The gasket pressure was varied by adding the following weights:

- 0 kg added weight
- 4 kg added weight
- 8 kg added weight

5.4.5 Results

The raw data is presented below (Figure 5.16) in four charts, one for each gasket tested.

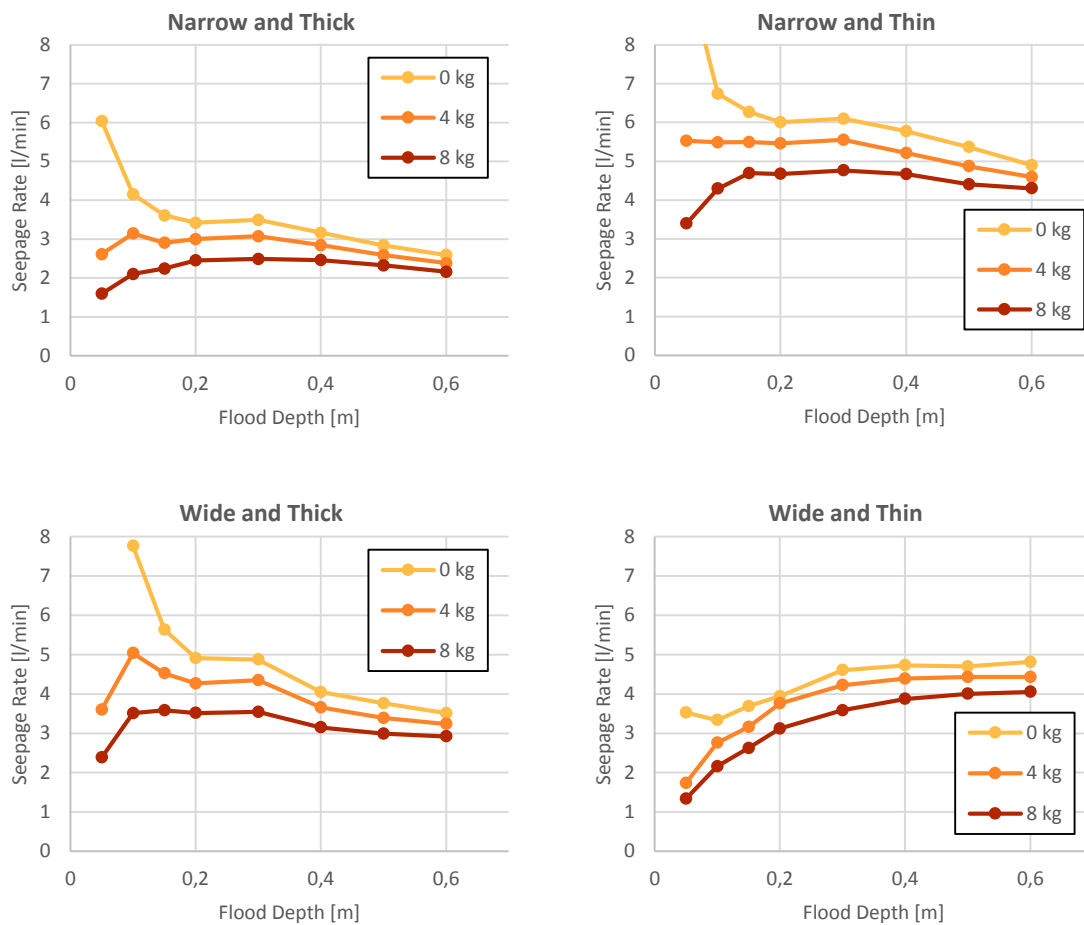

Figure 5.16 Results

What is immediately clear when interpreting the data is that adding weight reduces the seepage rate, especially at very low flood depths (0.05 meters). This suggests that adding weight is most effective at reducing seepage rates at low water depths.

It is also apparent that a thick gasket yields the best results in terms of seepage rate as it converges at roughly 2-4 liters per minute for the “narrow and thick” and the “wide and thick” gasket, while ending up at roughly 4-5 liters per minute for the thin gaskets. This can be explained by the thicker gaskets allowing for larger deformations to “fill in” the ground surface to create a seal.

For the thick gaskets, the narrow gasket yields lower seepage than the wide gasket. This is as predicted, since a narrow gasket leads to a higher gasket pressure, while the seepage pressure remains constant.

The main reason for performing this experiment was to investigate and establish a relationship between the seepage rate, the gasket pressure, and the seepage pressure. To get more data points to work with, the data from the ‘narrow and thick’ and ‘wide and thick’ gaskets were combined and plotted against the ratio: gasket pressure/ seepage pressure (Figure 5.17) to see if there is a relationship.

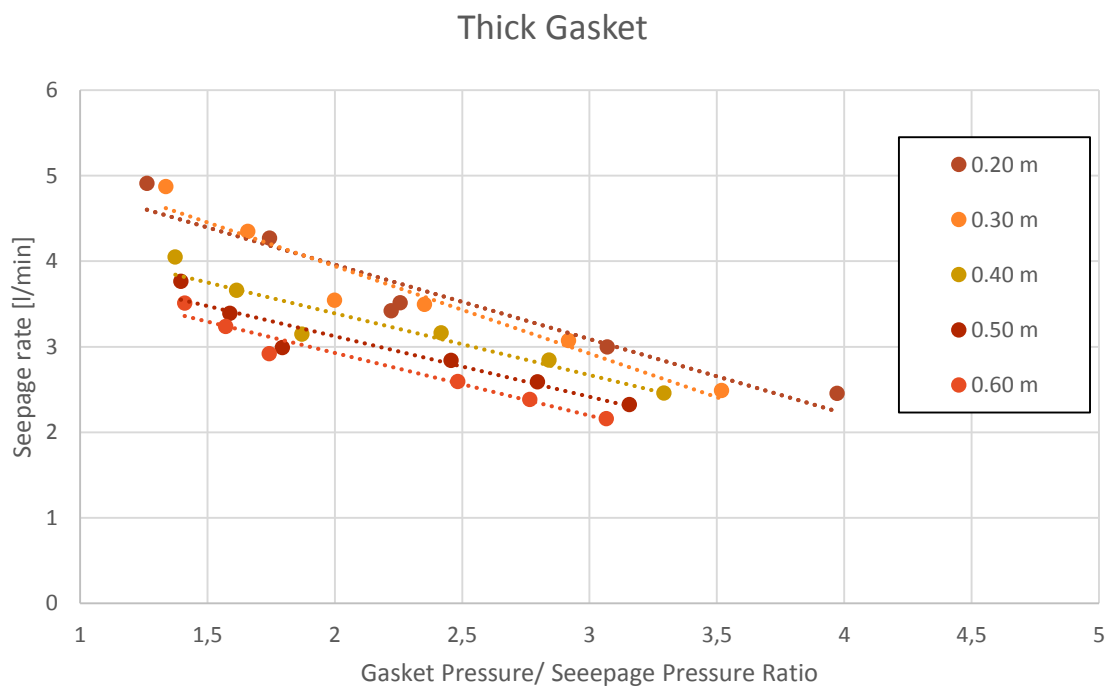

Figure 5.17 Relationship between seepage, gasket pressure and seepage pressure

The trend lines in Figure 5.17 seem to be parallel to each other, which suggests that there is a direct relationship between the seepage rate and the gasket pressure/seepage pressure ratio. The plan was to redo the test to eliminate error in the data. This would be done by, among other things, doing multiple recordings at each flood level, adding more weight to get a bigger span of results, and testing all water depths for each loading case before adding more weight. Adding weight and removing weight during the experiment might have a significant impact as it compresses and decompresses the gasket and might not give it sufficient time to return to its new equilibrium. However, it turned out that time had a greater impact on the results than anticipated (see section 5.4.6) and the experiment therefore needed to be repeated.

5.4.6 Developing an improved test set up

It was discovered that the seepage rates were time-dependent, so the initial experiment was conducted again but with 15 minutes between each recording to allow the seepage rates to stabilize. When it was discovered that the seepage rate continued to decline after 15 minutes, it was deemed necessary to redesign the test setup. Since the time needed for stabilization was potentially long, it was deemed beneficial to create an automated set up that conduct the experiment and collect data automatically.

The new test set-up would need improvements on two aspects of the initial test setup:

- Maintaining a constant flood depth
- Periodically recording the seepage rate.

In the initial test setup, the flood depth was kept constant by monitoring the depth visually, and adjusting the rate of water supply into the bucket accordingly. This method required constant monitoring and was therefore not suitable for maintaining a constant flood depth in an automated setup. The seepage rate was measured by periodically weighing the seepage water over a given amount of time. This is a labor-intensive process that requires multiple steps, and it is therefore not suitable for the new setup.

The new setup (see Figure 5.20) was built around an Arduino controlling the rate of water entering the flood bucket and recording the seepage rates (see Figure 5.21). The code used is included in *Appendix C – Arduino code for automated gasket experiment*.

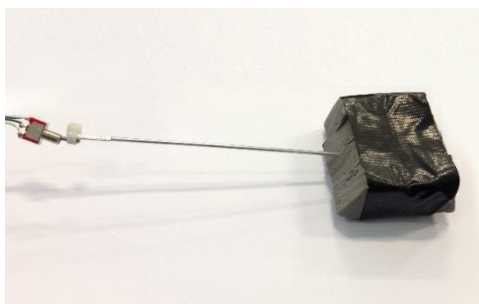

Figure 5.18 Float switch



Figure 5.19 Solenoid valve and flowmeter attached to water supply

A float switch was built (Figure 5.18) by attaching a foam material on a lever to a toggle switch that when triggered sends a signal to an input switch on the Arduino. This lets the Arduino know if the flood level is higher or lower than the desired depth, allowing it to adjust the water

level by turning on or off a solenoid valve (an electromechanically operated valve that switches on and off by an electric current) (see Figure 5.19) connected on the hose supplying water to the flood bucket. The solenoid valve operates at 12V so it is controlled using a relay switch. The hose supplying water to the flood bucket is connected to a faucet so the Arduino can control the amount of water supplied.

As the flood level stabilizes on the desired depth, the frequency that the solenoid valve is turned on and off increases. Initial testing of the system had the solenoid valve turning itself on and off more than once every second. To reduce the wear on the solenoid valve, a delay was incorporated to limit the frequency. This is the reason the float switch was not connected directly to the solenoid valve as was originally the plan, but rather through the Arduino.

There was no quick and easy way to measure the amount of seepage. However, since the flood level is being kept constant by adding water to the flood bucket, the amount of water going into the system is equal to the amount of water going out of the system. A flowmeter was therefore added to the water supply hose and connected to an input pin on the Arduino.

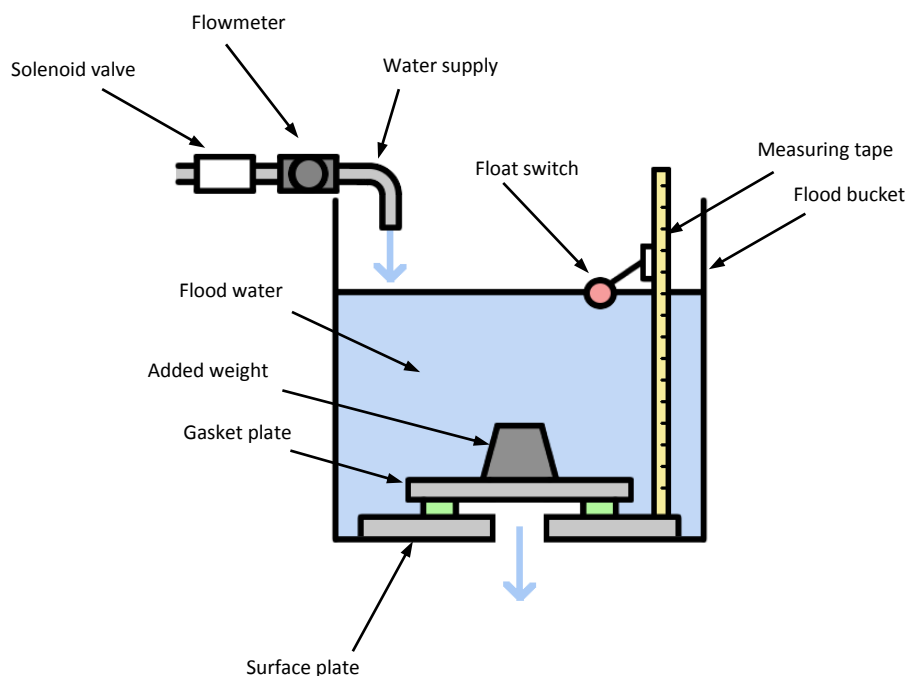

Figure 5.20 Diagram of test setup

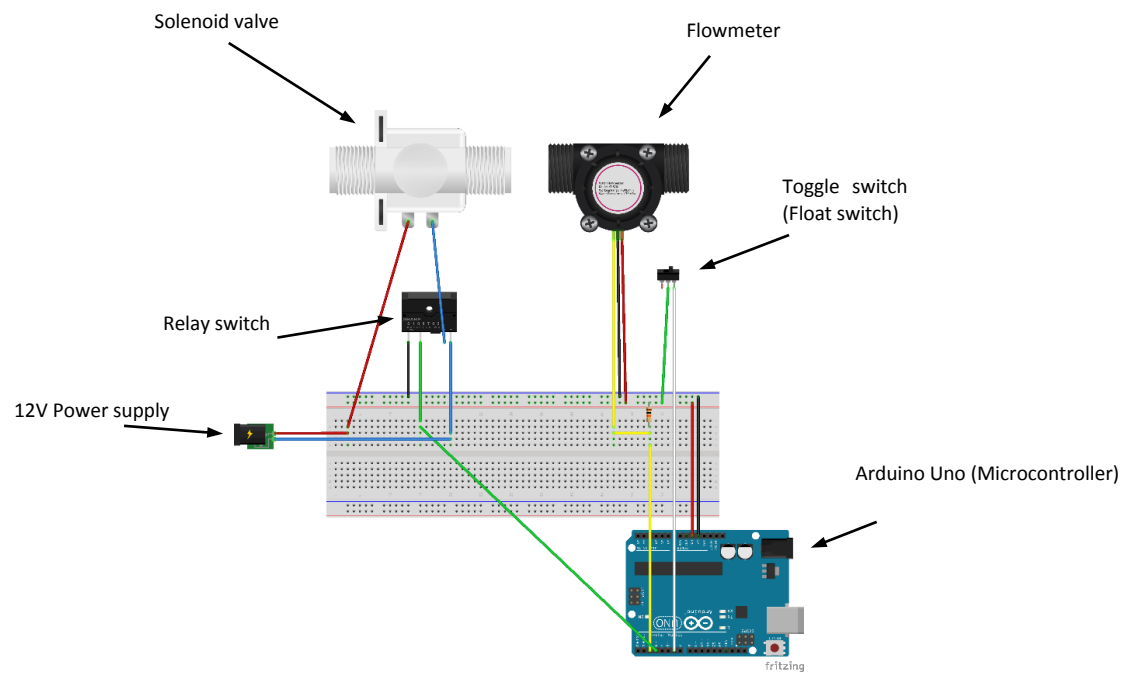

Figure 5.21 Layout of Arduino components

5.4.7 Results

The raw data from the experiment is presented on the left in Figure 5.22 on the next page, and is divided into the graphs, one for each of the three different depths tested. For each depth, three plots are shown, one for each of the three load cases (0kg, 10kg and 20kg added weight). As expected, an increase in weight correlates to a decrease in seepage rates. This is most clearly seen at a flood depth of 0.2 m, while not as clear for the two other depths. This is because the pressure on the gasket comes from the water pressure and the added weight, and as the flood depth increases, the amount of contribution from the added weight decreases relative to the water pressure. At 0.2 m the gasket pressure increases by 53% when using 20kg added weight compared to 10kg, while at 0.6m the gasket pressure increases by only 23%. In addition to this, the seepage pressure is three times higher at 0.6m than at 0.2m which is why the effect is more significant. This can be seen in the combined chart, where the highest seepage rate and the lowest seepage rate are both at a flood depth of 0.2m.

The graphs on the right side of Figure 5.22 present the same data as on the left, but in standardized form by multiplying the seepage rate with the gasket/seepage pressure ratio. This means the data shows what the seepage rate would be expected to be given that the gasket/seepage pressure ratio was 1. For this assumption to be correct, it would mean that the curves for the seepage rates would all be the same in the standardized form, which seems to be correct. This can be seen when comparing the combined graph of the standardized data to the raw data in Figure 5.23.

The seepage rate in the standardized graphs are also presented as “per meter”. The seepage rates were divided by the length of gasket used, so the seepage rate is per 1 minute, per 1 meter. The expected seepage rates for a system can then be estimated by multiplying the value with the length of barrier being used, and by the time.

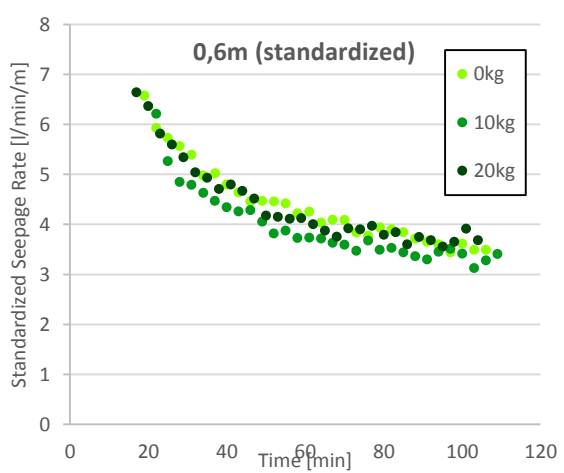
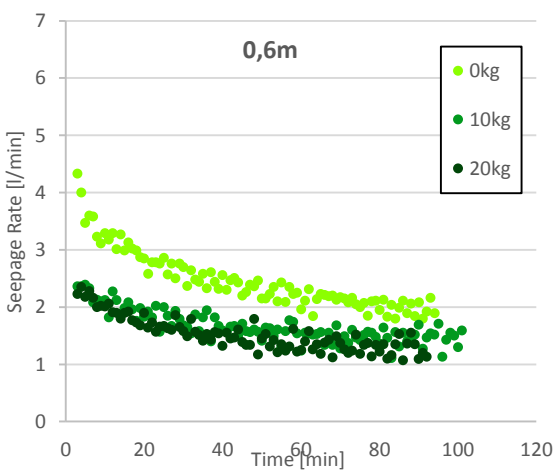
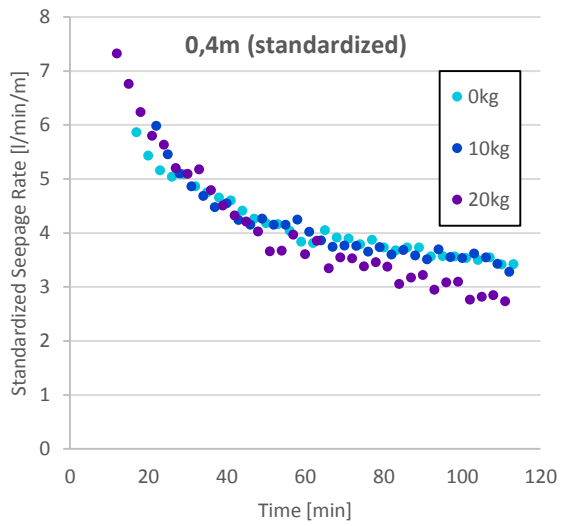
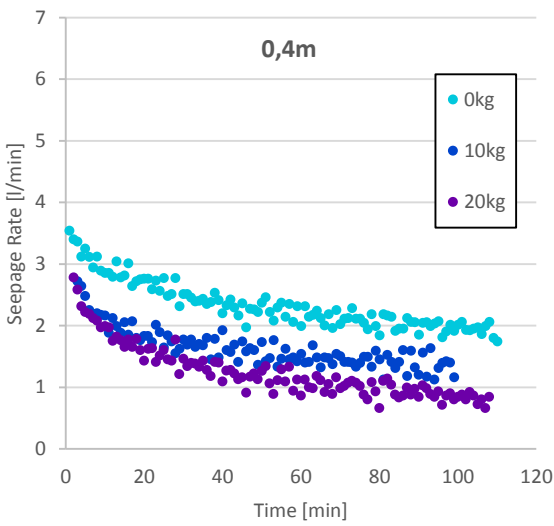
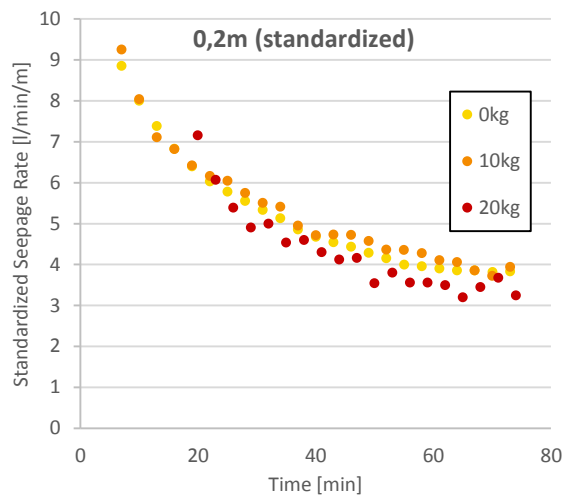
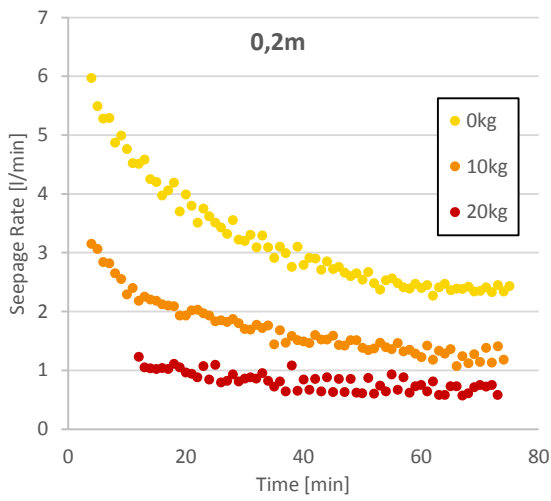

Figure 5.22 Results

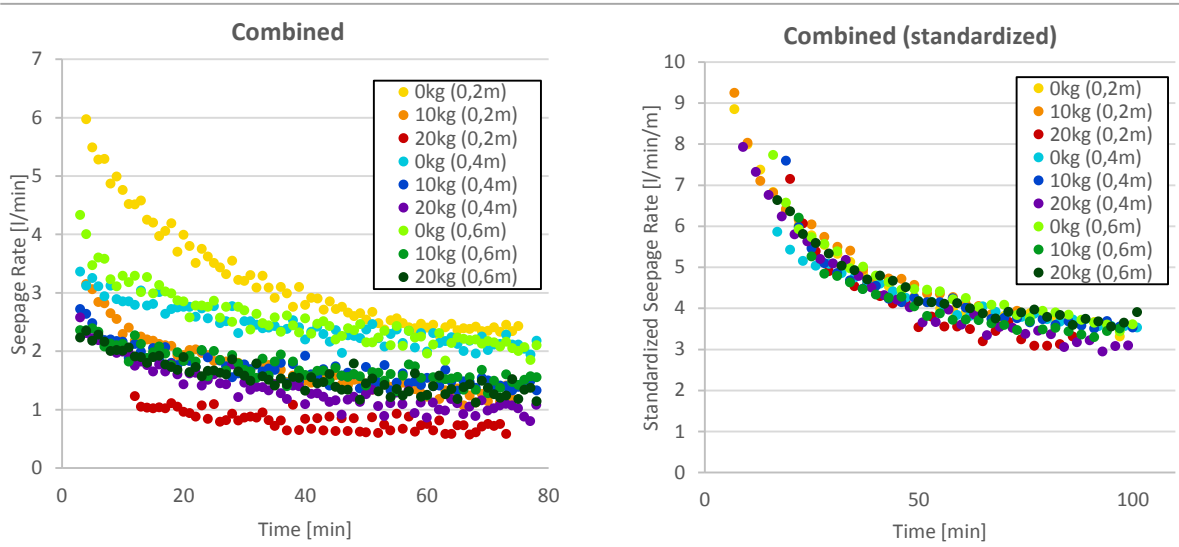

Figure 5.23 Combined

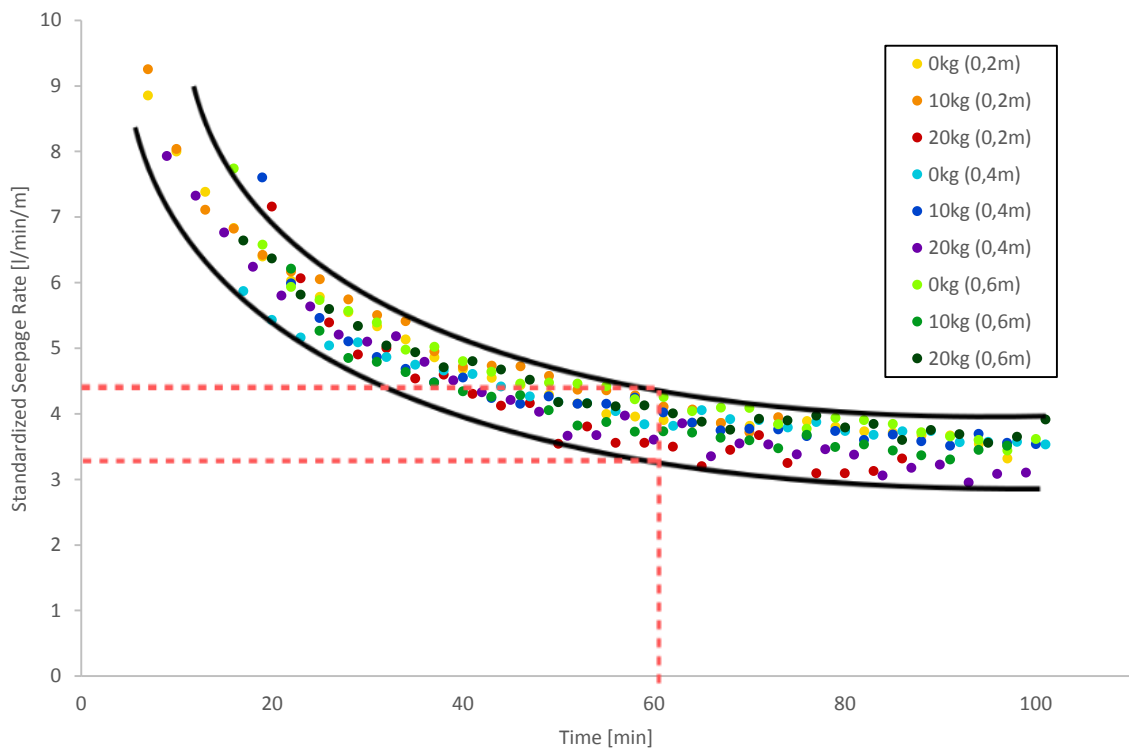

Figure 5.24: Combined (Standardized)

The data points in the standardized graphs do not line up perfectly which could be because it is not a perfect assumption to make, or from errors in the measurements, or a combination of the two. However, they line up close enough so that it can be used as an estimate, and by creating an upper and lower limit (represented by the black lines in the graph in Figure 5.24), it is possible to estimate a range that the seepage rates will fall into.

The expected seepage rate is calculated by finding the standardized seepage rate from the graph and dividing it by the gasket/seepage pressure ratio.

For example, the seepage rate at 60 minutes is calculated by finding the upper and lower limit at 60 min in the graph above (shown by the dotted line). The standardized seepage rate's upper value is roughly 4.3 and the lower limit is roughly 3.2. If the Gasket/seepage pressure ratio is 2, then the predicted seepage rate is between 2.15 l/min/m and 1.60 l/min/m.

It is often more useful to see what the seepage rates will be after they have stabilized. Figure 5.25 shows the stabilized seepage rate for the gasket/seepage ratio. The graph is constructed by averaging the ten last data points of each data set and plotting them against the gasket/seepage pressure ratio. Again, the points do not match up perfectly, so an upper and lower limit (represented by the black lines) is added to define a range the seepage rate is expected to lie within. Since this graph shows the seepage rates not in standardized form it means the values can be read directly from the graph.

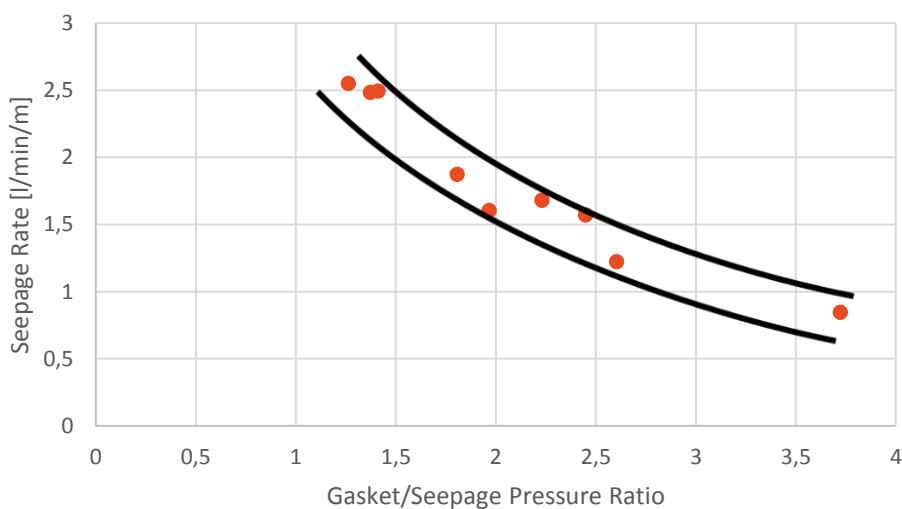

Figure 5.25 Time stabilized and standardized

5.4.8 Limitations

Only one gasket and one surface has been tested for this project. When using this experiment to determine which gasket would be the best, it is necessary to test multiple gaskets on different surfaces.

There are a lot of factors that affect the seepage rate, and perfectly replicating each scenario in a lab is not feasible. The results are also only valid within the range tested. Even though it looks like the data can be extrapolated, there might be unknown effects as the gasket/seepage pressure ratio goes towards zero or as the value gets very high. If the area of interest lays outside of the data collected, it is recommended to do more testing.

The experiment has only been performed once per data point, meaning there might be sources of error not discovered. For more reliable data, the experiment should be performed multiple times.

The experiment also does not take ground-water seepage into consideration, which on some surfaces can be a considerable factor. In this case, geological analysis is required to get an estimate for seepage rates, as it is not possible to test with the current test set up.

The seepage rates calculated in this experiment have been for gaskets that have not been exposed to water or pressure over an extended period of time, which would be expected for a gasket used in an actual flood protection system. It is therefore necessary to gain an understanding of how the gasket behaves over longer time intervals than done with this experiment. Gaining information about the life expectancy of the gasket is crucial if it is to be used in a finished product.

6 Concept Development

6.1 Resources

6.1.1 Prototyping equipment

Most of the physical prototypes were built using simple materials like paper, cardboard and plywood. To enable testing with water, a PVC canvas was obtained. In addition to having access to basic tools, a CNC wood router was available to use. CAD models were created with Siemens NX.

6.1.2 Size template

Physical prototypes are easier to relate to, compared to drawings and CAD models. To get a better understanding, two generalized prototypes (Figure 6.1) were built in full scale (0.6 m x 0.6 m). The prototypes were used as a tool for communication, and were used in brainstorming for explaining new design ideas. The understanding of several aspects of the system was improved:

- The size of the system
- The magnitude of forces acting on a system
- Interaction between a system and the user
- Interaction between modules
- Feasible module length
- Indication of module weight



Figure 6.1: Cardboard template prototypes

6.1.3 Universal test container

Conducting tests involving water for flood protection systems is a comprehensive task, and it is therefore valuable to develop test rigs that can be reused for different concepts. As most experiments consists of a container that is filled with water, a universal test container was developed. The container was required to allow prototypes and test equipment to be mounted in it, and needs to withstand the forces that occur at high water depths. It is critical that the container is secure, as it will potentially hold hundreds of liters, which means the consequences of a failure are high.

The first iteration of the test container (Figure 6.2) was built out of plywood sheets, reinforced with wooden beams, and sealed with silicone. Measuring 0.4 m in width, the tank accommodated testing of half scale modules (Figure 6.3). The tank was filled using a bucket to move water from a buffer tank to the test tank (Figure 6.4). Seepage water would exit the tank through a hole at the end, and fall into the buffer bucket that was placed underneath.



Figure 6.2 First iteration of a universal test container



Figure 6.3 Test of a prototype in the first iteration container



Figure 6.4: First iteration of test rig in use

The test tank served as a tool to investigate sealing characteristics of early prototypes, as well as the stability of single modules. However, several shortcomings were identified, and suggested improvements for the next iteration of a universal test rig were identified:

- Accommodate testing of full scale modules
- Higher durability and not degrading when exposed to water over long periods of time
- Automated filling of water
- Accommodate implementation of tools for measuring water flow in and out of the tank

The second iteration of a universal test container (Figure 6.5) was built out of stainless steel sheets that were welded together. The container was 1.5 m long, 0.8 m wide and 0.7 m high. The bottom of the tank was rectangular to be able to test systems of two lengths by either mounting the system across the length or the width.

A crib was built for the container that enabled the rig to be moved using a pallet lift. Also, by raising the container off the ground it was easier to empty it through a drain pipe attached to the base.



Figure 6.5 Second iteration of a Universal test container

6.2 Early phase concept development

Early phase concept development was done through iterative brainstorming and prototyping within the design space established in Section 4.6. Numerous ideas surfaced and several concepts were explored. The most promising concepts were selected:

- Tetris (Section 6.3)
- Caterpillar (Section 6.4)
- FlexiFront (Section 6.5)

6.3 Tetris

6.3.1 First Idea and explanation of concept

The name “Tetris” developed from the structures resemblance to the blocks of the video game with the same name.

The Tetris concept is a modular system based on rigid L-modules where the amount of rigid structure is minimized and canvas is used as the main material for the barrier. This increases the maximum angle that two adjacent modules can have to each other, as they can be rotated without colliding. It was also meant as a measure to reduce the weight of the system, as the previously heavy rigid structure would be replaced by canvas.

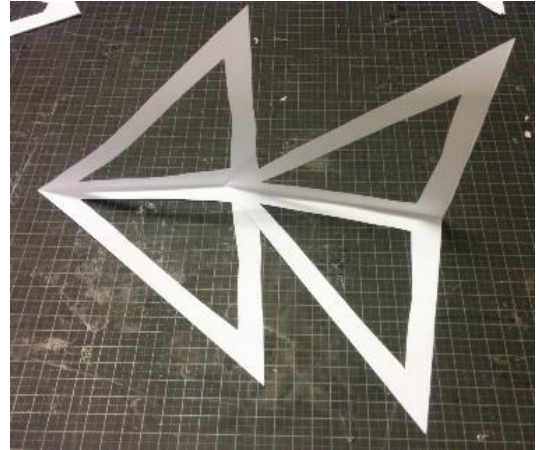

Figure 6.6 Prototype of the first idea

The Tetris system is made out of two main components: the frame and the canvas. The frame is the rigid part that supports the canvas and gives the modules its strength, while the canvas acts as the barrier stopping water from passing through.

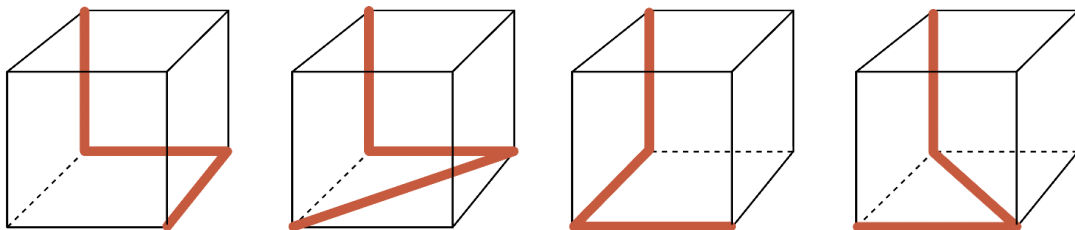

Figure 6.7 Different configurations for the structure of the Tetris concept

Simple prototypes were created from paper (Figure 6.6) to quickly visualize which configurations seemed to work best. The concept evolved into consisting only of straight beams, and several configurations were explored (Figure 6.7). The connection between the structures could either be on the front (towards the flood) or on the back (towards the area being protected). Connecting the structures on the back means the length of the back is constant, which makes it is easier to strengthen the structure while still allowing the modules to rotate. However, the front lengths would not be constant and this is where the gasket would need to be. Because creating a seal that can vary in length is more of a challenge than strengthening the structure, a front connected structure was chosen (Figure 6.8). Additionally, having the

connection at the front leads to an increase of base area when adjacent modules are placed at an angle, meaning that the hydrostatic pressure on the rigid parts gives a greater contribution to stability.

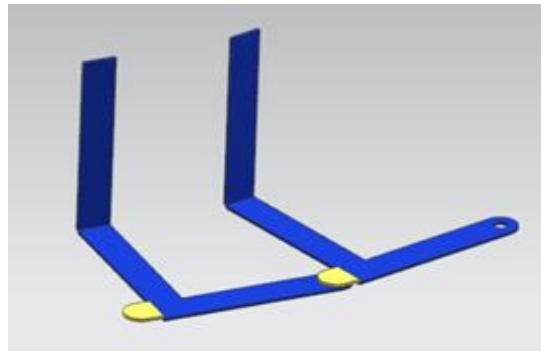

Figure 6.8 A CAD-model of the first iteration of the Tetris concept with front connection

6.3.2 Proof of concept

As rigid freestanding barriers rely on the rigid base plate for stability, and in the Tetris concept most of this area is removed, the largest uncertainty was whether the system would be stable enough.

To investigate the feasibility of the concept in terms of stability a conservative calculation was made. It was assumed that the hydrostatic pressure exerted on the base canvas gives no contribution to the stability (see section 5.3.1). The stability calculation was done for a maximum water depth, by calculating the moment around the tipping point of the module.

The calculated moment was positive, meaning that the simplified module would be self-stabilizing. The width of the structure was chosen arbitrarily and can be varied for a more stable structure, but the calculations indicated that it is possible to construct a flood barrier based on the Tetris concept that would be stable enough.

6.3.3 Physical prototype

Two identical physical prototypes were built (Figure 6.10) as a tool to visualize the concept and to explore the interaction between two modules. The prototypes were built in a 1:2 scale to make them easier to work with, while still being large enough for useful testing later on. A connection between the frames was developed (Figure 6.11), based on the ‘tabs and blanks’ of a jigsaw puzzle piece, that allows the modules to pivot while still being connected to each other.

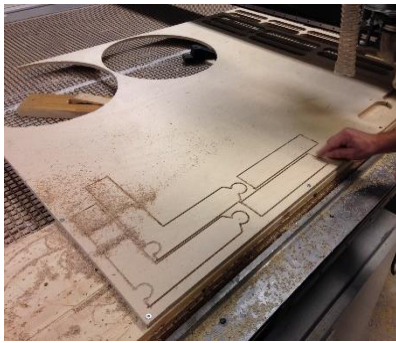

Figure 6.9 Routing plywood parts



Figure 6.10 The assembled Tetris prototypes

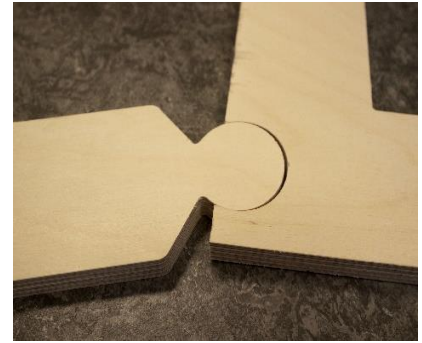

Figure 6.11 Close up of connector

The prototype was designed as a CAD model, and using a CNC woodworking router the pieces were cut out of a 12mm plywood sheet (Figure 6.9) and glued together. A woodworking router was chosen to build the prototypes because they could be built quickly and with high accuracy, at a low cost.

Due to the asymmetric nature of the Tetris module there was a concern that it would be diagonally unstable, but the physical prototype indicated that this was not a problem. Another concern was how the canvas would behave with regards to buckling. The prototype was modified by attaching a fabric to the modules (Figure 6.12), and testing showed that buckling was not an issue. The fabric was later replaced with a PVC canvas (Figure 6.14) to more closely resemble a material that would be used in a final product.



Figure 6.12 Module with



Figure 6.13 Interaction between two modules with strengtheners



Figure 6.14 A later prototype with PVC canvas

6.3.4 Canvas fastening mechanism

The canvas from two adjacent modules needs to be connected in a way that creates a continuous seal along the flood barrier. In AqF's current systems, the modules are connected to each other with a section of canvas that is clamped down to the adjacent module. This securely fastens two modules together as well as adding flexibility to the positioning as the canvas can be bent. However, for the Tetris module the canvas needs to be as stretched out as for the canvas to contribute to the stability of the module. The clamping mechanism in AqF's current system is also relatively complicated as it consists of many additional parts, which increases the cost and risk of operational failure.

Different ways to create a flexible connection between the modules were brainstormed. It was concluded that the best mechanism would allow the canvas to attach to any point to the following module, thereby allowing the canvas to remain fully stretched, regardless of the angle between modules.

Three general fastening mechanisms were suggested:

- **Adhesive:** "Sticking" the two canvases together with some type of adhesive. For example, static forces, hook and loop (Velcro) or a non-permanent adhesive
- **Cam Locking:** Cam mechanisms that easily allow the canvas to be tightened, but prevents the canvas from moving in the opposite direction
- **Clamping:** Attaching the canvas by pressing the canvas directly onto the next module

Several ideas involving cam locking were explored but no solutions that could accommodate the angle created between the base plate and the wall plate was discovered. The cam locking concepts were therefore rejected.

Adhesive based solutions would not be greatly affected by the corner, and would allow quick set-up times, but issues finding an appropriate material that would be strong enough while also being reusable, meant these ideas also were rejected. Precautions would also need to be made to prevent dirt from coming in contact with the adhesive during storage and set-up. A hook-and-loop mechanism is less affected by dirt, but it is difficult to create a watertight seal using this mechanism.

A clamping mechanism was chosen as the most promising mechanism for connecting the canvas of one module to the next, mainly due to its simplicity. A triangular piece was created that could be placed over the canvas and tightened using straps (see Figure 6.15). The straps were extensions of the connected canvas, making the design simple, yet effective.



Figure 6.15 Triangle canvas fastening mechanism

This fastening mechanism also contributes to the strength of the system, potentially removing the need for extra support. Integrating functions in this way reduces the amount of parts needed for the system, which reduces the cost of the system and makes the system easier to use and store.

The design showed promising performance during testing (section 6.3.7), but further improvements should be made to:

- Increase the pressure between the connecting canvases to reduce seepage
- Simplify user experience
- Improve the reliability and durability

To increase the pressure between the connecting canvases the triangle was redesigned into an arch. (Figure 6.16). Tightening the strap will then push the triangle towards the corner and distribute the forces more evenly over the canvas. A ratchet strap can be used to gain sufficient pressure between the connecting canvases.

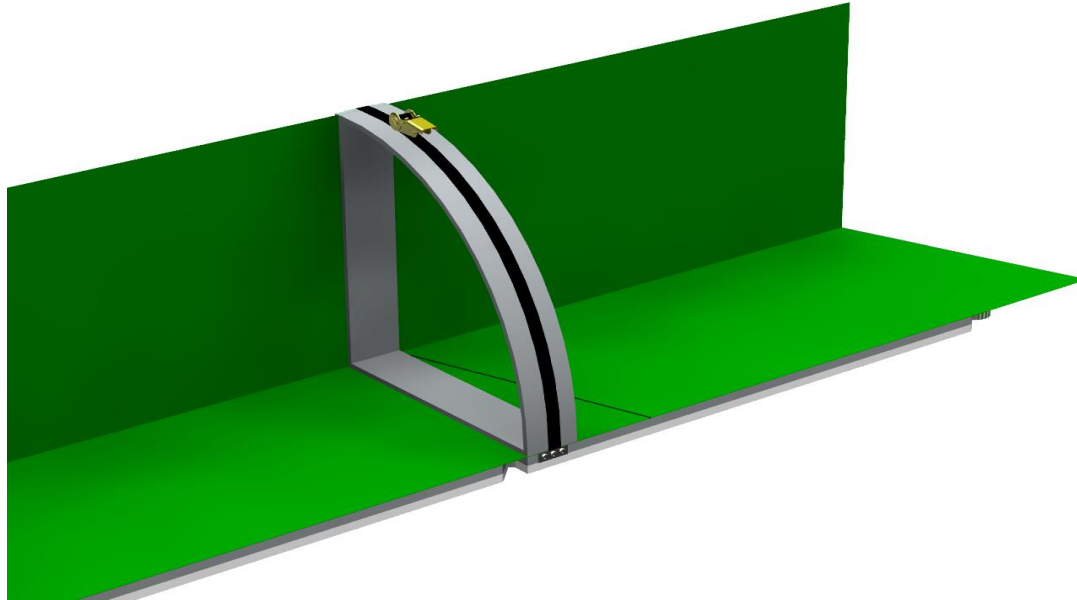

Figure 6.16 Suggested design with ratchet strap and a reshaped triangle

6.3.5 Frame joint

The original mechanism, which was based on a jigsaw puzzle, was meant as a temporary solution to evaluate other aspects of the concept. However, this mechanism proved to be a suitable solution for a connection between modules. This is because it is simple and does not require extra components, which reduces the cost of the system. The mechanism is also easy to understand, since it is familiar reference to most people.

As the joint is prone to seepage, a watertight sealing material will have to be applied to either the male or the female part of the joint. In addition, the joint has to be tight enough to ensure there is pressure on the sealing material. Figure 6.17 illustrates how a gasket could be applied to the female part of the joint. In addition to sealing the joint, it will make the connection between the modules firmer.

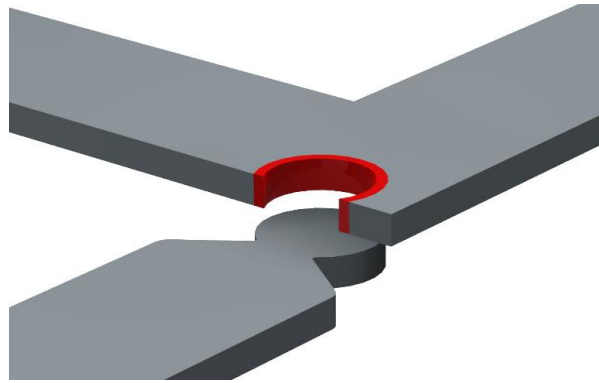

Figure 6.17 Suggested seal in the joint

6.3.6 User feedback on the frame joint and fastening mechanism

To get initial feedback on how intuitive the combination of the proposed joint and fastening mechanism was, a quick test was set up to see how two users, unfamiliar with the system, would interact with the design (Figure 6.18). Two people were each given a pair of modules and were instructed to connect the two modules together, without instruction on how to do it.

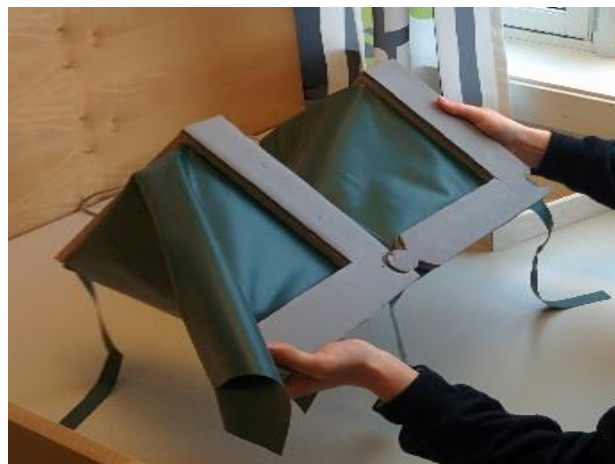

Figure 6.18 A person connecting two modules for the first time

Both test participants were able to set the system up correctly. However, confusion about the orientation of the modules resulted in high set up time.

This test was used as a quick way to get feedback and only gave an indication for how intuitive the configuration was. For more detailed feedback, more test participants should be recruited and efforts made to ensure a diverse group is selected.

6.3.7 Transport and storage

To decrease storage volume and increase mobility, the wall could be hinged, making the module collapsible (Figure 6.19). Since the canvas fastening mechanism adds strength and rigidity to system, the hinge mechanism can be made by separating the wall from the base, letting the canvas act as a hinge. This way, adding a hinge mechanism makes the design less complicated, by avoiding the need for joining of the wall and the base during production. Collapsible modules allow for compact stacking (Figure 6.20), which is useful for storage and transportation.

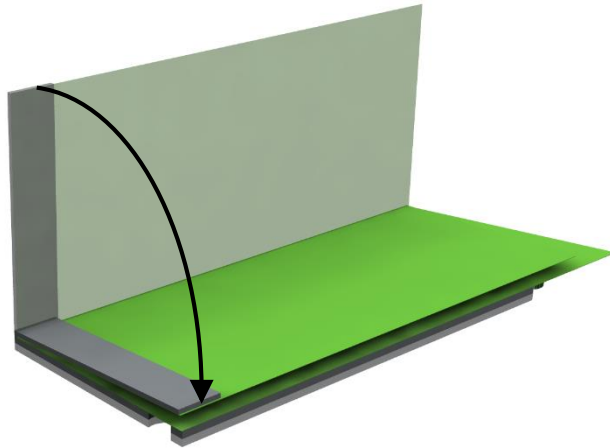

Figure 6.19 Collapsible Tetris module



Figure 6.20 AquaFence modules stacked for storage and transport

6.3.8 Directional Prototype

The feasibility of the concept was tested by building a comprehensive prototype and performing a water test (Figure 6.21). The purpose of the prototype and the test was to investigate whether or not to continue the development in the direction of a Tetris system, and to look for unexpected outcomes.

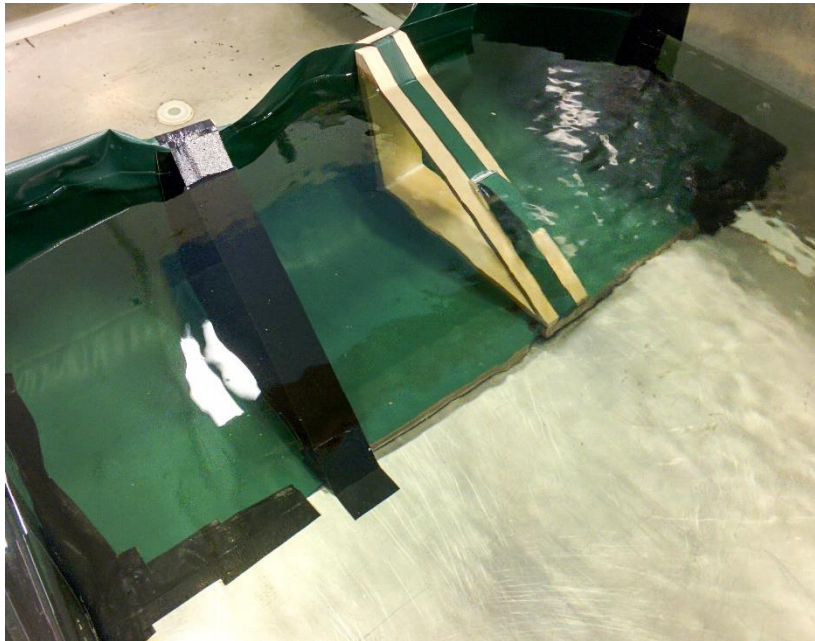

Figure 6.21 Test of directional prototype

The most crucial property to investigate at this point was stability. There was some uncertainty linked to the way the system was mounted, and to what extent this would provide extra stability to the system. However, the stability was deemed “good enough” to invest further work in the concept.

The test revealed the following:

- The flexibility in the joint enabled each of modules to be placed at uneven foundations (rotation in y-axis).
- The gasket was too thin to properly seal against the uneven foundation in the test tank
- All of the canvas was elevated from the foundation
- There was no leak detected through the connection between the modules.

6.3.9 Analysis of the frame dimensions

The structure of the system can be divided into three sections (Figure 6.22):

- Wall
- Middle
- Front

The length of the wall is determined by the maximum flood protection height (0.6m). The width of the wall is not believed to have any major effects on stability but does have an impact on the strength of the system. Therefore, the width of the wall will need to be determined based on a structural analysis of the module.

The length of the middle section has a great impact on the overall stability. Making the middle section longer increases the base area, and consequently the contribution from the hydrostatic downforce increases.

This is verified by the knowledge capturing system in Figure 6.24. However, effort should be made to keep this length as short as possible to minimize the base to height ratio, and to reduce storage volume. The width does not affect stability and needs to be based on a structural analysis. The thickness needs to be high enough to raise the canvas off the ground (see section 5.3.1)

Increasing the length of the front section (Figure 6.23) reduces the number of modules, which means the number of connections are also reduced. This improves the set up time, and reduces the number of complex parts per meter of barrier, which in return reduces the cost. However, the longer the front section is, the fewer wall sections exist, meaning each wall section will be subject to higher forces. It also affects the flexibility of the system as there are fewer pivot points.

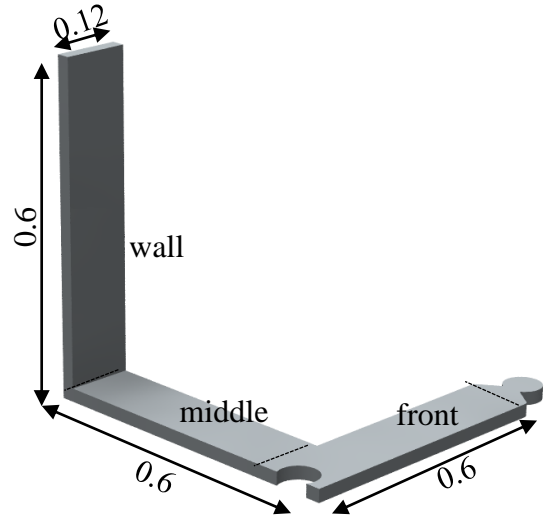

Figure 6.22 Tetris frame and its three sub-components, with initial dimension [m]

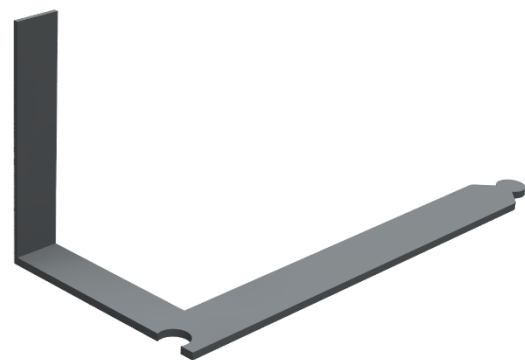

Figure 6.23 Tetris module with 1.2 m front

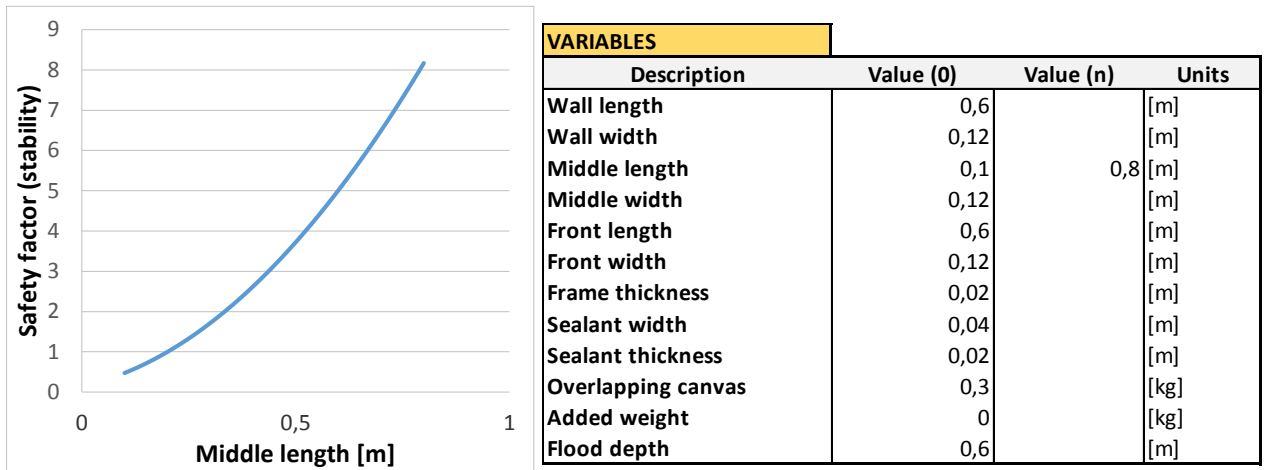

Figure 6.24 Graph showing the effects of middle length on stability (left) and variables used for the calculation (right)

6.3.10 Estimating seepage rates

The seepage rates of a Tetris system can be estimated using the knowledge capturing program (Section 5.2.3), which has incorporated the results from the automated gasket experiment (Section 5.4.7). The estimate is based on time-stabilized seepage and the seepage rate on the gasket pressure.

The estimated seepage rates do not account for seepage through/beneath the surface nor leaking through the system (connection between modules). The rates presented in Figure 6.25 will therefore be a low estimate.

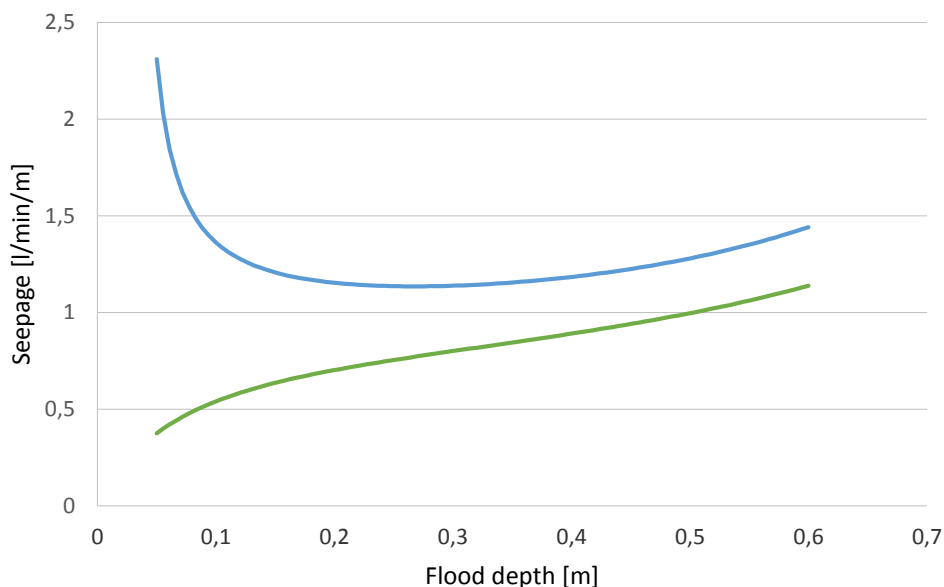

Figure 6.25: Estimated seepage rates (blue graph: no external weight, green graph: one sandbag per module)

The blue plot represents the Tetris system without any additional weight. The seepage rates is approximately 1.5 l/min/m, which means that a small gasoline-powered water pump, which is low cost solution, would be able to pump seepage water out of an enclosed barrier stretching over several 100 meters.

Sandbags can be used to increase the gasket pressure. By assuming that a sandbag (17kg) increases gasket pressure evenly, the expected seepage rate is seen as the green plot in Figure 6.25. The improvement is considerable, especially for low flood depths. In addition, the stability of the system will improve because of the added weight. Using sandbags to improve overall performance should therefore be considered. The negative aspects of using sandbags have been discussed in section 3.4, but the amount needed for the extra stability is negligible compared to the amount needed for a sandbag barrier.

6.4 Caterpillar

6.4.1 First idea and explanation of concept

The Caterpillar concept evolved from the desire to reduce the number of connections in a system, which has been identified as one of the main causes of system complexity. This is achieved by having long modules with permanent connections. The starting point for designing the shape of the system was a long canvas L module (Figure 6.26). Two rapid prototypes were made out of fabric that were used as a tool when investigating possible design solutions.

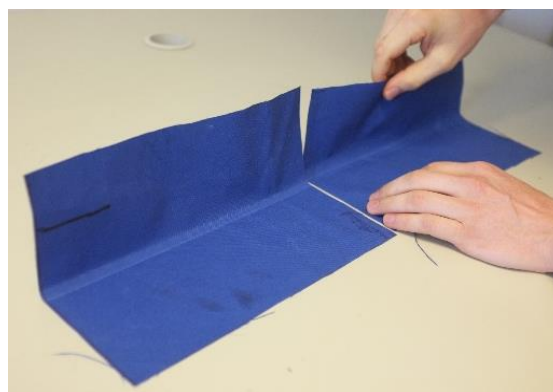

Figure 6.26 rapid prototyping

6.4.2 Designing the rigid structure

Two concepts for the rigid structure were explored. Either, the canvas could be lifted above the foundation to contribute to the stability, or rigid plates would at the base of the system would give the system its stability. Early 3D models illustrating both concepts can be viewed in Figure 6.27.

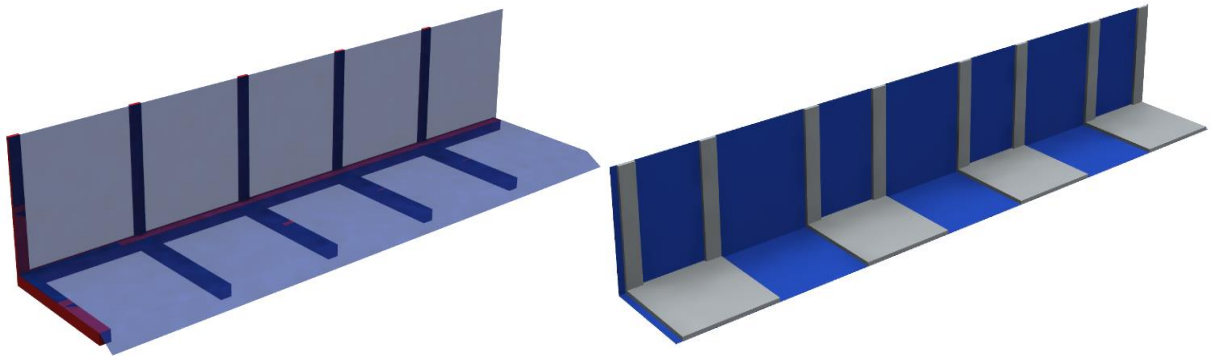

Figure 6.27 CAD model of Caterpillar with lifted canvas (left) and rigid plate elements (right)

The concepts that lifts the canvas could be designed to be lighter than the concepts with plates. However, it would rely on complicated solutions to allow canvas to be tightly attached and be collapsible.

The rigid plate concept naturally divides the structure into elements, which enables the system to be made collapsible in a simple way. In addition, the plate concept will perform well in terms of stability. Generally, the plate concept represented great performance in many key areas of the initial design stage.

6.4.3 First iteration and prototype

The plate concept was considered the best solution and was therefore developed further. By dividing the rigid elements into a base and a wall, it allows each element to be collapsible. By making a slot in the base and a corresponding tab in the wall, they could easily be mounted together. A prototype made out of PVC canvas and plywood elements was made (Figure 6.28).

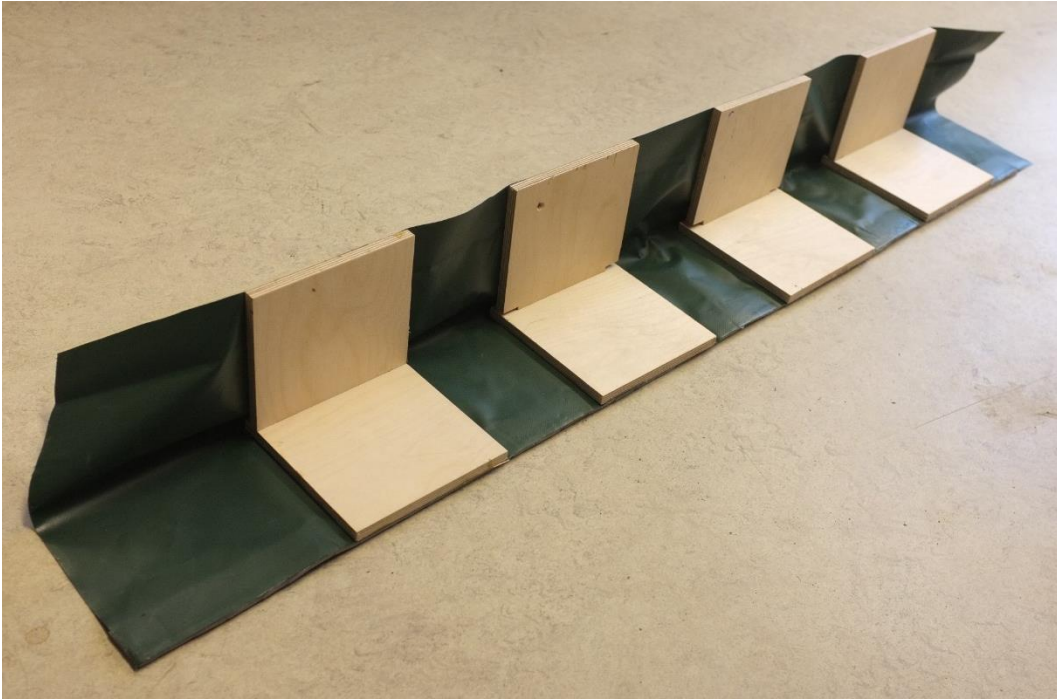
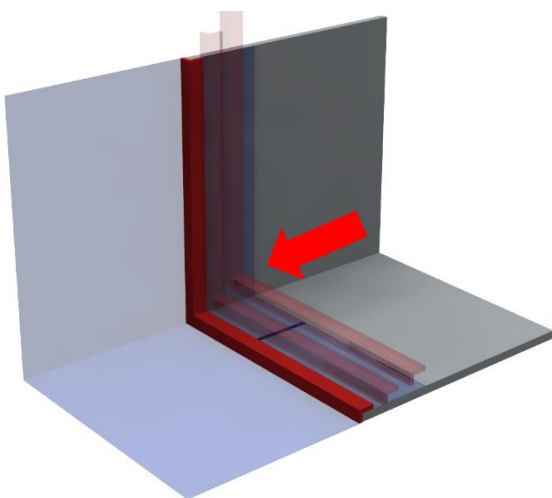

Figure 6.28 Caterpillar plywood and PVC canvas prototype

6.4.4 Connection between modules

To form a continuous waterproof barrier a solution to connect the modules together needed to be developed. The first idea was to clamp the end of the canvas from one module onto the frame of the adjacent module, using a rigid section.

Solution 1:



Solution 2:

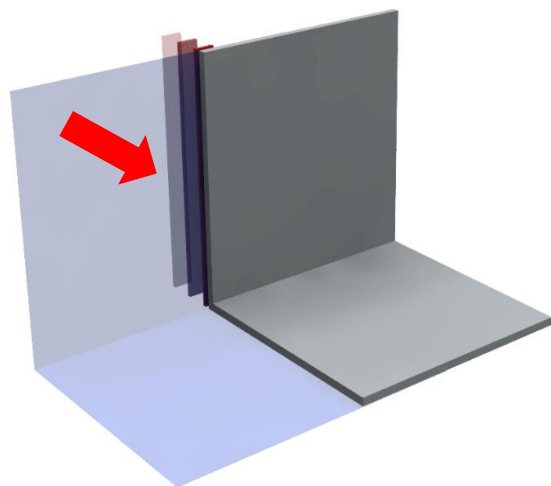

Figure 6.29 Clamping of canvas, solution 1 and 2

Two solutions for fastening the canvas is presented in Figure 6.29. Solution 1 fastens the canvas on top of the element, while solution 2 fastens the canvas underneath the element.

When fastening the canvas on top of the element, the clamping part needs to be a L-shaped cross section to seal between the side of the element and the canvas. In addition, the clamping part is required to seal against both the base and the wall. Fastening the canvas underneath the base, requires the base to have a gasket, and may be a source of seepage if the foundation is uneven, especially in the corner between the base and the wall.

Another possibility that was explored was using waterproof zippers to connect the modules. By equipping each module with a male zipper at one end, and two female zipper on the other, two different attachment points for the adjacent module is available:

1. Directly to the end of the L-cross section to form a straight continuation of the barrier
2. To the backside of the wall to form a 90 degree corner

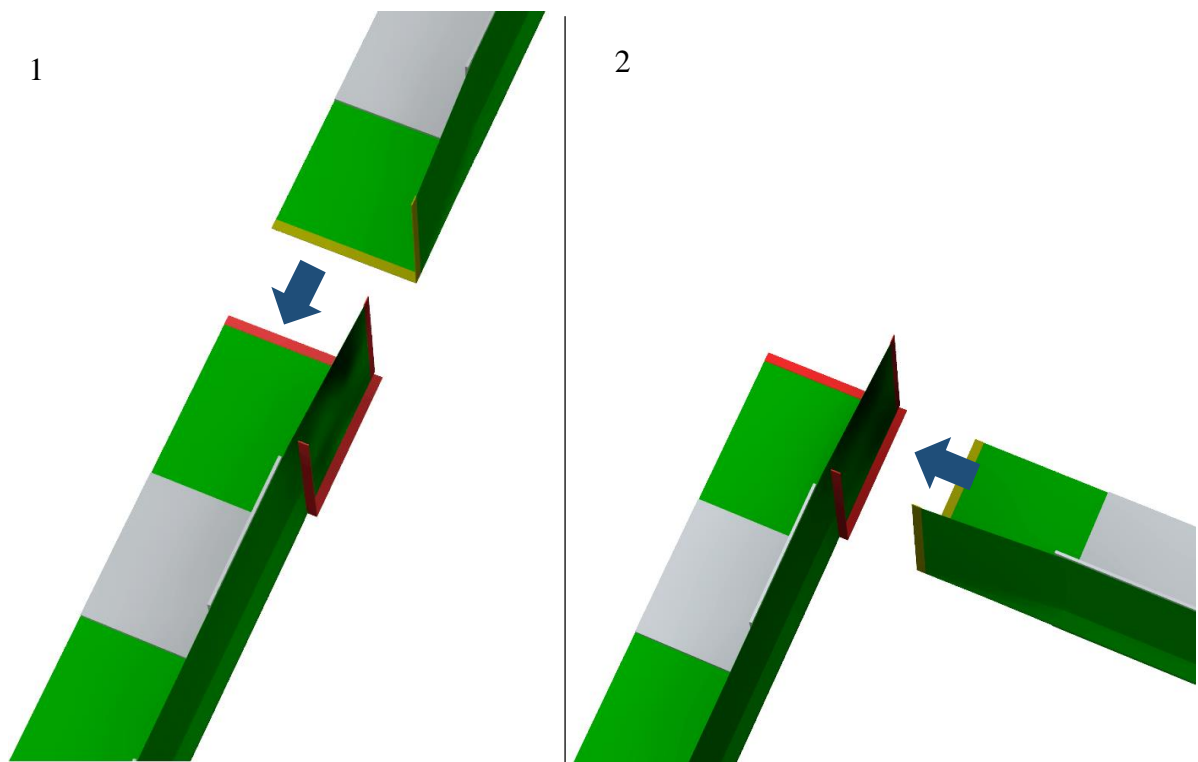

Figure 6.30: Connection option 1 and 2

Figure 6.30 illustrates the two connection options. This solution offers highly improved rotation around z-axis flexibility (see section 4.4.4), and makes it possible to form an enclosed barrier using only one type of module. This reduces the system complexity by eliminating the need for special modules to form corners.

6.4.5 Storage and transportation

Due to each module being (potentially) several meters long, they need to be collapsible to be simple to handle in transportation, and to reduce storage volume. By allowing the wall and base to be separated, with each element's wall and base only connected by the flexible canvas, the system can be folded. Investigating the prototype gave an answer to how the modules could be efficiently packed (see Figure 6.31). In addition to being compact, the system needs to be as light as possible to make it easier to handle in transportation and when mounting the barrier.



Figure 6.31 Packing of module

6.4.6 Directional prototype

A directional prototype was tested (Figure 6.32) in the universal test container to investigate the feasibility of the concept further. It performed well in terms of stability but did not seal satisfyingly. However, sealing capabilities are believed to improve noticeably in the case of a larger scale prototype. Sealing between the elements proved to be the greatest issue, which points out the need for a design that increased gasket pressure between the elements.

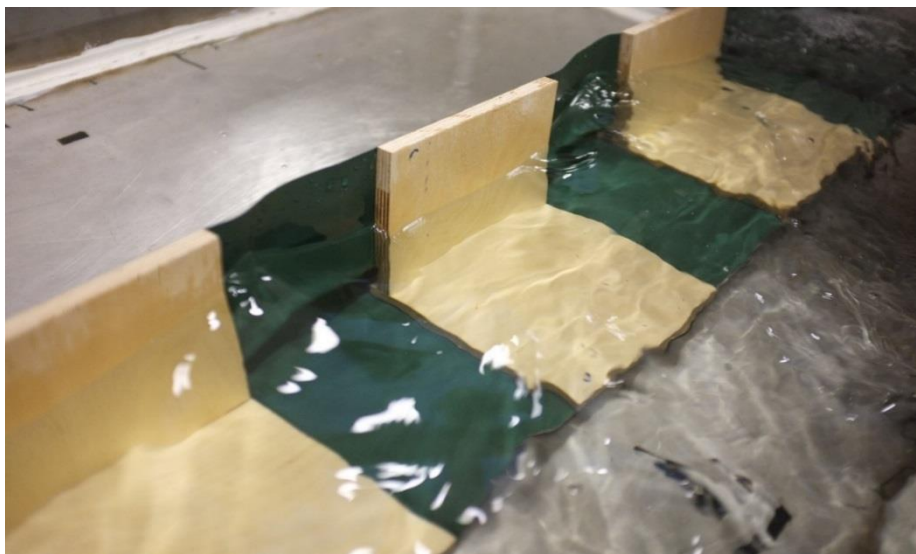

Figure 6.32 Directional prototype of Caterpillar

6.4.7 Sealing between the elements

Creating a good seal between the elements is the biggest challenge for the Caterpillar design, especially at low flood depths. The seepage rate needs to be decreased by increasing the gasket pressure. As increasing the weight of the modules is not a desired solution, sandbags can be used as external weight (Figure 6.33). This is a low-cost solution which allows the modules to be light-weight for transportation.

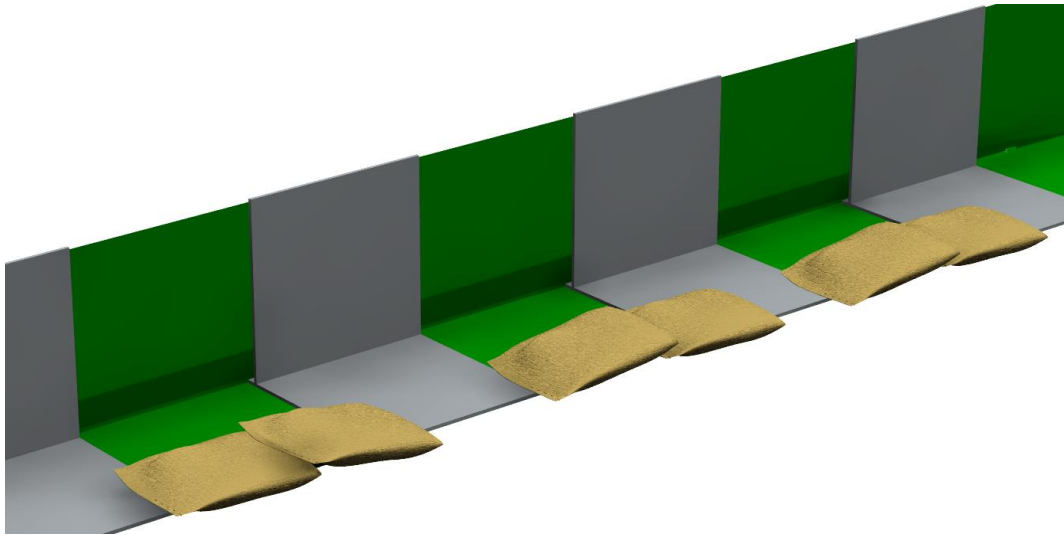

Figure 6.33: Using sandbags to improve sealing between elements

6.4.8 Improving element strength

The current design relies on the connection between the base and the wall to take up all the forces acting on the wall of the module. The strength of the joint depends on both the material of the elements, and the design of the joint. A structural analysis will need to be performed to determine if the joint is strong enough, and the addition of strengtheners (Figure 6.34) should be considered. For the modules to continue to be collapsible, the strengtheners need to be flexible.

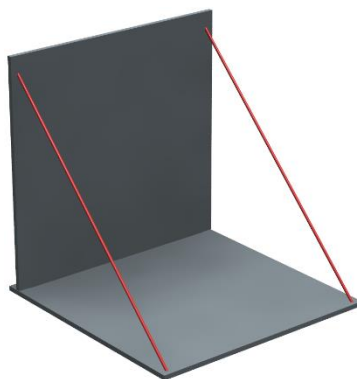

Figure 6.34: Strengtheners added to Caterpillar element

6.4.9 Analysis of the dimensions

The properties of the system can be affected by changing the dimensions (Figure 6.35): module width, number of elements, element distance, element depth, and module length.

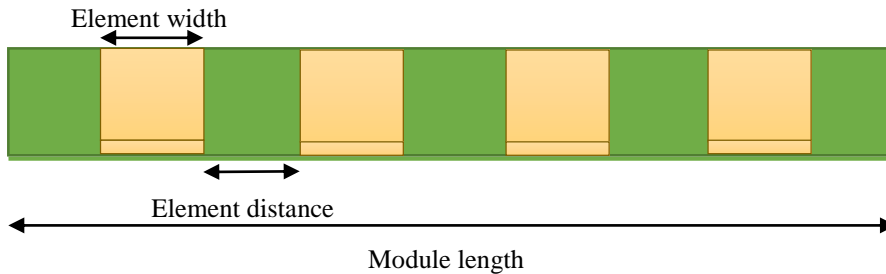

Figure 6.35: Important dimension of Caterpillar modules

One of the most important design choices will be the ratio between elements and canvas. Firstly, this will affect the stability of the system, as the greater the share of elements, the more stable the system will be. Secondly, a module with a low share of elements will lead to a lighter, cheaper, and more flexible system.

The stability of the system is greatly affected by the element distance and was therefore explored further using the Knowledge Capturing System (see Figure 6.36). In the case of element distance being 0.6m, the safety factor of safety is about 1.1, which is not acceptable. By reducing, the element distance to 0.4 the safety factor is improved to about 2. By reducing the element distance further, some of the key advantages of the system, like system flexibility and the weight of the modules will be affected negatively. With more comprehensive testing at a later stage, adjustments can be made to optimize the element distance.

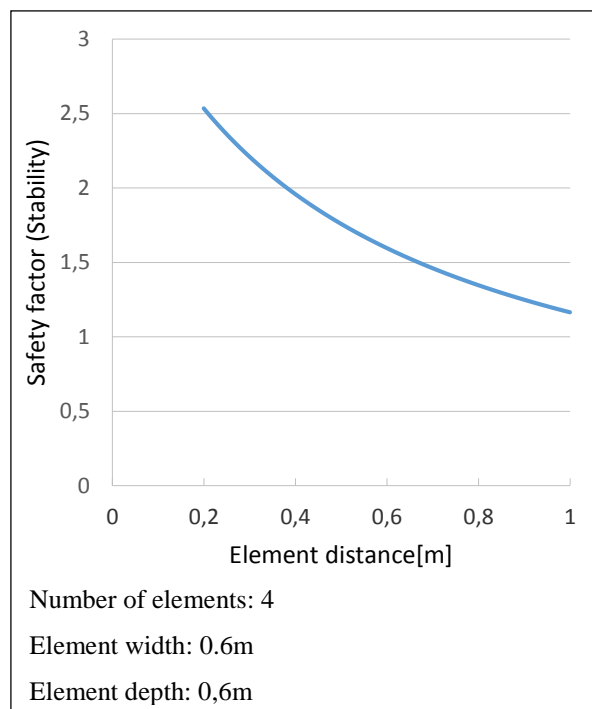

Figure 6.36 Stability factor of safety vs element distance

In order to fulfill the idea of reducing connections, the length of the modules is desired to be as long as possible. The module length is mainly limited by the module weight. The requirement

in terms of weight, is that two people are able to move the system. Considering that, the material of the elements has not been determined, choosing a final number of elements is not optimal at this stage. However, calculations performed with the Knowledge Capturing System indicate that the modules should consist of between 3-5 elements.

6.5 FlexiFront

6.5.1 Idea and explanation of concept

FlexiFront is a partial system that can be implemented as a part of other systems. The idea for FlexiFront surfaced during the examination of the terrain in typical use cases. Most locations have obstacles that would cause poor system performance if a system would be installed directly over the obstacle. For example, the installation in Figure 6.37 would lead to critical seepage rates. Most systems available today require either, improvement of the foundation, customized modules or external components like sandbags to achieve satisfactory sealing capabilities.

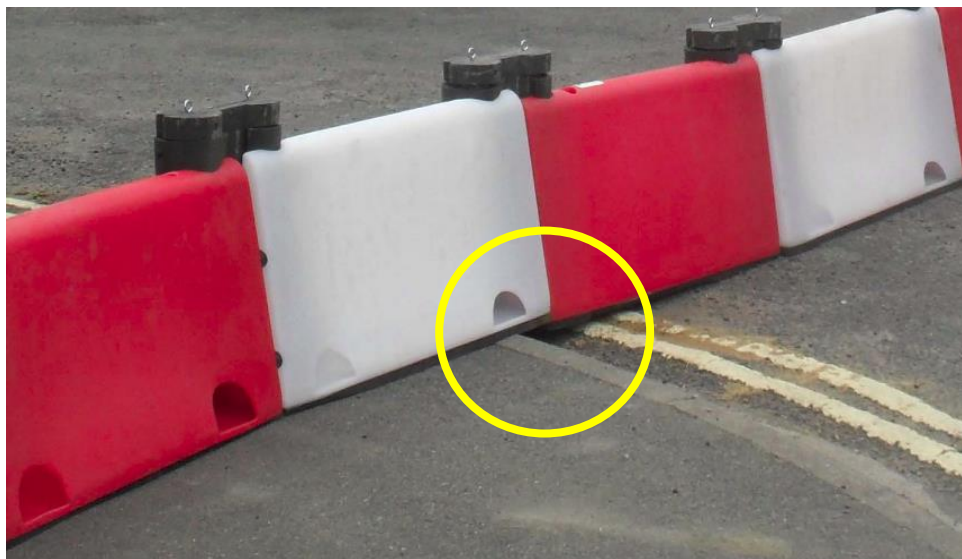

Figure 6.37: Rigid system (Fluvial) placed directly on a curb

FlexiFront is a flexible canvas and gasket component that allows several add-ons to be attached on top of the gasket to improve sealing in difficult areas. This allows the user to attach components that are customized for a specific scenario.

FlexiFront is not a concept for a complete system but a feature that can be incorporated into other concepts or systems to achieve better sealing in areas with uneven foundations. FlexiFront can be a part of a systems design, or be added as a skirt in front of the system.

Three add-ons were developed:

- **Weight belt:** Fabric tube filled with a heavy fill material. It is designed to be used in areas where the foundation is uneven.
- **Weight box:** A container filled with a heavy fill material that is designed to be used on 90-degree corners like on curbs. It functions much like a sandbag, but is able to seal corners better due to its rigid structure.
- **Flexible plate:** Flexible plate of sheet metal. It can be formed to inorganic shapes and used over curbs, but can also form natural shapes to be used on uneven foundations.

6.5.2 Prototyping and testing



A prototype of the FlexiFront system was made. Since the focus of the prototype was to see how it performed without the rest of the system, the prototype consisted of a 60x60 cm canvas square with an 8 cm wide seal at the front, and a strip of Velcro to attach add-ons, see Figure 6.38.



Figure 6.38: FlexiFront prototype

By making this simple prototype, quick but valuable feedback was achieved by testing on different foundations. Although sealing capabilities weren't tested directly, an indication for performance was gained by investigating the gap between the foundation and the gasket. The feedback gained through testing of the prototype is outlined in Table 10.

Table 10 Evaluation of FlexiFront add-ons

Add-on:	Findings and performance
<p data-bbox="229 367 316 400">None</p> 	<p data-bbox="922 448 1426 689">The prototype showed that canvas and gasket are too stiff to properly form to the foundation. This supports the assumption that the canvas itself does not offer adequate sealing for low flood levels.</p>
<p data-bbox="229 835 405 869">Weight belt</p> 	<p data-bbox="922 981 1426 1137">The weight belt was not heavy enough to sufficiently adapt to the foundation. There was some improvement, so a heavier weight belt is promising.</p>
<p data-bbox="229 1350 427 1384">Flexible plate</p> 	<p data-bbox="922 1518 1426 1630">Required some work to shape it to fit the foundation. Showed promising performance in most use cases.</p>

Weight box



Performed great in closing the gaps between the gasket and the foundation, but is limited to 90-degree corners.



The weight box was made so that the other two add-ons could be put on top of it.

The weight belt had little impact on the gasket pressure. Some improvement on each side of the weight box.



The flexible plate improved gasket pressure in the corner but lifted the canvas slightly on each side of the weight box.

6.5.3 Implementing FlexiFront in Tetris and Caterpillar

FlexiFront can be implemented in most flood protection systems, including Tetris and Caterpillar. This can be done in two ways:

- Attaching FlexiFront to the front of the system using a watertight fastening mechanism
- Integrating FlexiFront into the system directly, extending beyond the front of the system

FlexiFront could be especially useful in the Caterpillar system if it is placed between the elements (Figure 6.39), as this has been identified as a critical point for seepage.

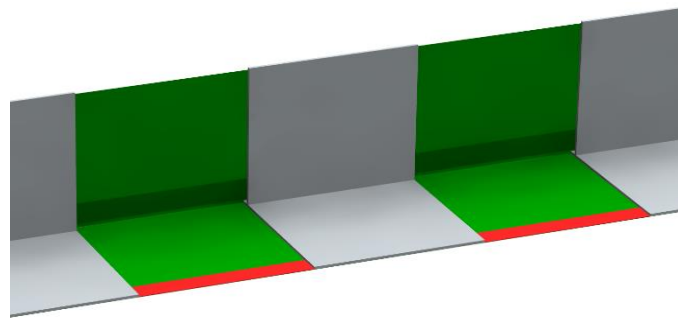

Figure 6.39: FlexiFront incorporated in Caterpillar

6.6 Evaluation of concepts

The extent to which extent the concepts fulfill the qualitative requirements established in section 4.6, is evaluated in Table 11 for Tetris and in Table 12 for Caterpillar. The evaluation is based on the tests performed, knowledge captured and intuition. A score from 0 to 1 is given for each measure where 0 requires no further attention, and 1 requires a lot of attention in the further development of the concepts.

Table 11 Evaluation of qualitative measures for Tetris

Qualitative	Score	Explanation
Low cost system	0.75	The system consists of few mechanisms and few additions, but effort needs to be made to keep production costs low, especially due to the geometry of the rigid parts.
Compact when not in use	0.5	The folding mechanism needs to be optimized and stacking methods developed.
High flexibility	0	The flexibility of the current design is its strongest feature.
Fast installation	0.25	Connecting modules is relatively fast, but due to the high number of connections needed in a full system, extra measures should be made to optimize the connection mechanism.
Build user trust/confidence	0.5	The structure could be perceived as flimsy due to the relative amount of canvas being high.
Avoid operational failure	0.75	The connection between modules is promising, but due to the importance of correct use, extra attention should be directed towards optimizing this.
Avoid structural failure	0.25	A structural analysis needs to be performed to select satisfactory dimensions for the structure.
Avoid functional failure	0.5	Further testing needs to be performed to select a gasket to minimize seepage rates. In addition, the connection between modules is a potential source for function failure and needs to be addressed.

Table 12 Evaluation of qualitative measures for Caterpillar

Qualitative	Score	Explanation
Low cost system	0.25	The system consists of few parts that each have a simple geometry. The water-proof zipper is potentially a high-cost part
Compact when not in use	0	The folding mechanism renders the system compact, and does not require a lot of further development
High flexibility	0.25	The length of the modules restricts flexibility.
Fast installation	0.5	The main issue is mobility of modules due to their weight. Efforts should be made to reduce the weight of the modules.
Build user trust/confidence	0.25	The large rigid structures offers a solid impression, but the canvas between could be perceived as “flimsy”.
Avoid operational failure	0.25	Insuring that the added weight is placed correctly.
Avoid structural failure	0.25	A structural analysis needs to be performed to select satisfactory dimensions for the structure.
Avoid functional failure	0.5	Further testing needs to be performed to select a gasket to minimize seepage rates. In addition, creating a seal between the elements must be addressed further.

6.7 Further work and industrialization of concepts

6.7.1 Materials and production

Although the design of the product could change during further work, investigating different material and production options is valuable, as further development should be initiated with this in mind. The components of each concept can be divided into four main categories: the canvas, the rigid parts, gaskets and the add-ons.

6.7.1.1 *Rigid parts*

The rigid parts of the systems can be produced in a range of materials. The prototypes were produced in plywood, because of easy and accurate manufacturing using a CNC woodworking router. As AqF uses marine grade plywood for their current products, and considering the flat and simple geometry of the rigid parts in the concepts (Table 13), this is a feasible production material. For low production numbers marine grade plywood is believed to be a low cost option. However, production time will be high, especially for the Tetris frame due to the connection mechanism. In addition, the arch design of the canvas fastening part (see Table 13), requires bending of the plywood, which is a complicated time consuming process. A different material should therefore be considered for this part.

For larger production series, molded plastic is believed to be a low-cost alternative compared to plywood. Although the initial investment of molds are high, they are believed to pay off if the production series reaches a certain size. Plastic also offers advantages in terms of storage in harsh humid conditions.

Table 13: Geometry of rigid parts

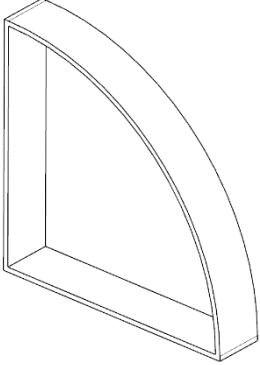
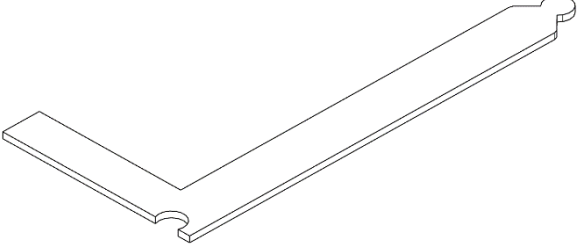
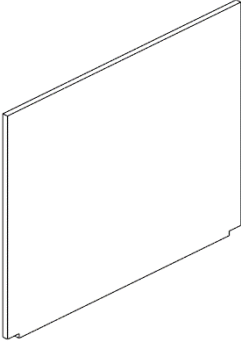
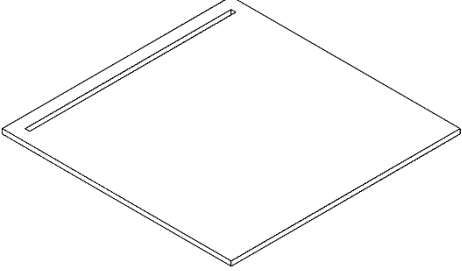
Tetris		
Wall	Canvas fastening part	Base
		
Caterpillar		
Wall	Base	
		

6.7.1.2 Canvas

The canvas used to build the prototypes was chosen mainly for accessibility in local hardware stores. However, during testing, it proved strong and durable. The canvas was similar to the canvas AqF uses, but it was slightly thinner. As the forces in the consumer model is lower, the thinner canvas is a promising option.

Both Tetris and Caterpillar depend on the canvas being attached to the rigid parts (frame and elements). The current solution that is used for the prototypes, is a contact adhesive. The benefits of this is that it keeps the product complexity low as it avoids the use of additional parts like bolts and brackets. If the frame is made out of plastic, welding the canvas to the frame is a possible solution.

6.7.1.3 Gasket

Thorough testing should be conducted with several gasket types to select the best one. The material used in the late prototypes of Tetris and caterpillar showed promising sealing performance. However, testing of durability should be performed to ensure that the sealing capabilities do not decrease after use and long-term storage. The gasket experiment that was developed in section 5.4.6 is a useful tool for evaluating the gaskets.

6.7.1.4 Add-ons

Effort has been put into reducing the number of add-ons for the systems as a way to reduce the costs, and to simplify the operational processes. Currently, the add-ons suggested are a watertight zipper for Caterpillar, and ratchet straps for Tetris. Alternatives to these add-ons should be investigated further.

6.7.2 Involving manufacturers

By introducing manufacturers to early concept designs, the development can advance with feedback on how to design solutions can be produced at a low cost. AqF should include their current manufacturer to get this feedback, and possibly other manufactures to investigate new methods of manufacturing.

AqF possess unique knowledge about flood protection systems. Although they have provided valuable insight about flood protection systems, it is believed that a more direct involvement of AqF in the next phases of development can contribute to designing better systems. This includes feedback on concepts and prototypes, as well as sharing general knowledge on flood protection systems.

6.7.3 Certification

AquaFence's success in the flood protection market is largely based on the certification performed by FM Global. In addition to being a good selling point, FM Global informs potential customers about AquaFence. Therefore, requirements for certification should be established as design guidelines for further development.

7 Conclusion

This project is a resource that can be used for developing flood protection systems. A framework and method for development has been established that outlines aspects of flood protection systems that are especially important for the consumer market. Even if the two concepts presented are not pursued, subsystems can be implemented into other systems. In addition, useful tools and methods that can be used in development of new concepts have been presented.

The conclusion will address each objective individually:

I. Develop novel concepts for consumer flood protection barriers

Based on the potential market for consumer flood protection systems, a design space for the development was established. Qualitative and quantitative requirements were established for the concepts being developed. Based on these requirements two promising complete concepts (Tetris and Caterpillar) and one partial system (FlexiFront) were developed. Both complete concepts met the quantitative requirements established. The qualitative requirements have been addressed, and design solutions have been developed based on these requirements, but further work (summarized in section 6.6) is needed to fully achieve this. Steps towards industrialization of the concepts were outlined in section 6.7.1, but need to be examined further as development moves forward.

II. Develop new innovative ways for testing desired aspects of new concepts

Two comprehensive experiments were executed: Seepage rates for gaskets (section 5.4) and canvas contribution (section 5.3). The results from the seepage experiment verified the benefit of adding external weights on the modules to reduce seepage rates at low water depths, and gave an indication of the expected seepage rates for the concepts. The test setup that was designed is also useful for development after this project for evaluating and selecting a gasket. It can also be used for investigating the effects of gasket geometries and materials.

The canvas experiment proved that a rigid-flexible hybrid is a viable configuration for consumer flood protection systems. The test setup that was designed is also useful to evaluate the overall stability of concepts, including those not addressed in this project.

III. Design and build a functional test set-up for comprehensive prototypes

The test container was designed and built to be as universal as possible. This allowed quick experiments to be conducted as a tool to explore the design space and to quickly gain knowledge about specific design features. This was for example, useful during the testing of directional prototypes in section 6.3.8 and 6.4.6. Furthermore, the test container allowed comprehensive experiments to be rigged inside the tank.

IV. Establish a system for capturing knowledge gained during development

The knowledge capturing system (section 5.2) that was created was a useful tool to capture knowledge from the experiments and the relationships established between the properties of the concepts. The main potential for this system is reusing the knowledge that has been captured to aid further development of the systems.

8 References

- Bogers, M., & Horst, W. (2013). Collaborative Prototyping: Cross-Fertilization of Knowledge in Prototype-Driven Problem Solving. *Product Development & Management Association*.
- Bryan-Kinns, N., & Hamilton, F. (2002). One for all and all for one? Case studies of using prototypes in commercial projects. *NordiCHI*.
- Buchenau, M., & Suri, J. F. (2000). *Experience Prototyping*. San Francisco: IDEO.
- Elverum, C. W., & Welo, T. (2015). On the use of directional and incremental prototyping in the development of high novelty products: Two case studies in the automotive industry. *Journal of Engineering and Technology Management*.
- Federal Emergency Management Agency. (2015, June 15). *Protecting Your Businesses*. Retrieved December 13, 2015, from FEMA: <http://www.fema.gov/protecting-your-businesses>
- Federal Emergency Management Agency. (2016). *Flood Facts*. Retrieved from National Flood Insurance Program: <https://www.floodsmart.gov/>
- Ghosh, S., & Seering, W. (2014). Set-Based Thinking in the Engineering Design Community and Beyond. *ASME*.
- Hirabayashi, Y., Mahendran, R., Koirala, S., Konoshima, L., Yamazaki, D., Watanabe, S., . . . Kanae, S. (2013). Global Flood Risk Under Climate Change. *Nature Climate Change*.
- Houde, S., & Hill, C. (1997). What do Prototypes Prototype? In *Handbook of Human-Computer Interaction*. Elsevier B.V.
- Kennedy, B. M., Sobeck II, D. K., & Kennedy, M. N. (2013). Reducing Rework by Applying Set-Based Practices Early in the Systems Engineering Process. *Wiley Online Library*.
- Koppe, B., & Brinkmann, B. (2010). Opportunities and drawbacks of mobile flood protection systems.

- Lim, Y.-K., Stolterman, E., & Tenenberg, J. (2008, July). The Anatomy of Prototypes: Prototypes as Filters, Prototypes as Manifestations of Design Ideas. *ACM Transactions on Computer-Human Interaction*.
- Macher, J. T., & Mowery, D. C. (2003, September). “Managing” Learning by Doing: An Empirical Study in Semiconductor Manufacturing. *Journal of Product Innovation Management*.
- McCurdy, M., Connors, C., Pyrzak, G., Kanefsky, B., & Vera, A. (2006). Breaking the Fidelity Barrier: An Examination of our Current Characterization of Prototypes and an Example of a Mixed-Fidelity Success. *Association for Computing Machinery*.
- Ogunyoye, F., Stevens, R., & Underwood, S. (2011). *Delivering Benefits Through Evidence-Temporary and Demountable Flood Protection Guide*. Bristol: Environment Agency.
- Oxford University Press. (2016). Retrieved from Oxford Dictionaries: <http://www.oxforddictionaries.com/>
- Schrage, M. (1993). The Culture(s) of Prototyping. *Design Management Journal*.
- Smith, P. G. (2007). *Flexible Product Development: Building Agility for Changing Markets*. Wiley.
- The World Bank. (2010). *Economics of Adaptation to Climate Change*. Washington DC.
- Tidd, J., & Bodley, K. (2002). The Influence of Project Novelty on the New Product Development Process. *R&D Management*, p. 2002.
- Ulrich, K. T., & Eppinger, S. D. (2012). *Product Design and Development*. McGraw-Hill.
- UNISDR. (2011). Global Assessment Report on Disaster Risk Reduction.
- Ward, A., Liker, J. K., Cristiano, J. J., & Sobek II, D. K. (1995). The Second Toyota Paradox: How Delaying Decisions Can Make Better Cars Faster. *Sloan Management Review*.
- Ward, D. (2012). *AquaFence Summary of Laboratory Testing*.
- Wilby, R. L., & Keenan, R. (2012). Adapting to flood risk under climate change. *Sage*.

Appendices

Appendix A - Code for the Knowledge Capturing System

```
'Define module variables
Dim emptyrow As Integer
Dim stepcounter As Integer
Dim incounter As Integer
Dim outcounter As Integer
Dim pos(1 To 6) As Integer

Sub Button2_Click()
'comments are posted above action

'Define sub variables
Dim i As Integer
Dim j As Integer
Dim xrow As Integer
Dim yrow As Integer
Dim stepsize As Double

i = 1
j = 0
Do While i <> 7
    j = j + 1
    If IsEmpty(Cells(j, 1).Value) = False Then pos(i) = Cells(j, 1)
    If IsEmpty(Cells(j, 1).Value) = False Then i = i + 1
Loop

'Select the number of datapoints to collect
stepcounter = 100

'Calculates input size
incounter = pos(4) - pos(3)

'Calculates output size
outcounter = pos(6) - pos(5)

'Find xrow and yrow
xrow = pos(3) + Cells(2, 2) - 1
yrow = pos(5) + Cells(3, 2) - 1

'Find empty slot
j = 0
emptyrow = 0
Do While IsEmpty(Cells(34 + j, 10).Value) = False
    j = j + 1
    emptyrow = j
Loop

'calculate step size
stepsize = (Cells(xrow, 6) - Cells(xrow, 5)) / stepcounter

For i = 0 To incounter
'copy input min to input buffer
    Cells(pos(3) + i, 2).Value = Cells(pos(3) + i, 5)
Next i
For i = 0 To outcounter
'copy output buffer to output min
    Cells(pos(5) + i, 5).Value = Cells(pos(5) + i, 2)
Next i
```

```

'Calculates datapoints
For i = 0 To stepcounter
'Copy min column + (stepsize*step) into Buffer
For j = 0 To incounter
    Cells(xrow, 2).Value = Cells(xrow, 5) + stepsize * i
Next j
'Copy from buffer to data table
    Cells(34 + emptyrow, 10 + i).Value = Cells(xrow, 2)
    Cells(35 + emptyrow, 10 + i).Value = Cells(yrow, 2)

Next i

'Copy from buffer to output max
For i = 0 To outcounter
    Cells(pos(5) + i, 6).Value = Cells(pos(5) + i, 2)
Next i
'print x/y title
Cells(34 + emptyrow, 9).Value = "x(" & (emptyrow + 2) / 2 & ")"
Cells(35 + emptyrow, 9).Value = "y(" & (emptyrow + 2) / 2 & ")"
'add series
ActiveSheet.ChartObjects("Chart 2").Activate
    With ActiveChart.SeriesCollection.NewSeries
        .Name = ActiveSheet.Cells(35 + emptyrow, 9)
        .Values = ActiveSheet.Range(Cells(35 + emptyrow, 10), Cells(35 + emptyrow, 10 + stepcounter))
        .XValues = ActiveSheet.Range(Cells(34 + emptyrow, 10), Cells(34 + emptyrow, 10 +
stepcounter))
    End With

'label axes
With ActiveChart
    'X axis name
    .Axes(xlCategory, xlPrimary).HasTitle = True
    .Axes(xlCategory, xlPrimary).AxisTitle.Characters.Text = Cells(xrow, 4) & " " & Cells(xrow, 7)
    'y-axis name
    .Axes(xlValue, xlPrimary).HasTitle = True
    .Axes(xlValue, xlPrimary).AxisTitle.Characters.Text = Cells(yrow, 4) & " " & Cells(yrow, 7)
End With
End Sub

Sub Button82_Click()
'clear datapoints
Worksheets("Sheet1").Range(Cells(34, 9), Cells(35 + emptyrow, 10 + stepcounter)).Clear

'delete all series in chart
ActiveSheet.ChartObjects("Chart 2").Activate
    For Each s In ActiveChart.SeriesCollection
        s.Delete
    Next s
'clear output
Worksheets("Sheet1").Range(Cells(pos(5), 5), Cells(pos(6), 6)).Clear
End Sub

```

Appendix B - Equations used to establish relationships for Tetris

$=(B17*B18+B19*B20+B21*B22)*B23*B9$	Frame weight
$=(B17+B19+B22)*(B21+B26)*B12$	Canvas weight
$=B21*B24*B25*B10$	Sealant weight
$=B34+B33+B32$	total weight
$=((B41*((B19+B22)/2))+B40*(B21+(B22/2)))/((B42*B38)/3)$	Safety factor (stability)
$=IF(B28>(B25+B23);1;0)$	Is flood over base
$=(B28-B23-B25)*B37$	Flood height over base
$=(B19*B20*B23+B21*B22*B23)*B9+B21*B24*B25*B10+B21*B19*B12$	Weight of base
$=B27*B13$	Force from sandbags
$=B39*B13+B37*(B19+B22)*B21*B38*B11*B13$	Force on base
$=B38*B21*B38/2*B13*B11*B37$	Force on wall
$=(B41*((B19+B22)/2))+B40*(B21+(B22/2))-((B42*B38)/3)$	Moment at tipping point
$=(B43*(B22+B19-(B24/2)))/(B21*B24)/1000$	Gasket pressure
$=B28*B13*B11/1000$	Seepage pressure
$=B44/B45$	Gasket/seepage pressure
$=3,4315*B46^{-1,016}$	Seepage rate

Appendix C - Arduino code for automated gasket experiment

```
volatile int NbTopsFan; //measuring the rising edges of the signal
double Calc;
float CalcOld = 0 ;
int hallsensor = 2; //The pin location of the sensor
double Vol;
int delayLength = 200;
int realDelayLength = delayLength;
int floater = 6;
int relay = 4;
float timeNew = 0 ;
float timeOld = 0 ;
int floaterTest;
int val;
int timer = 0;
int timerTime = 60;
float seepage;

void rpm () //This is the function that the interrupt calls
{
    NbTopsFan++; //This function measures the rising and falling edge of the
    hall effect sensors signal
}
// The setup() method runs once, when the sketch starts
void setup() //
{
    pinMode(hallsensor, INPUT); //initializes digital pin 2 as an input
    pinMode(floater, INPUT); //initializes digital pin 2 as an input
    pinMode(relay, OUTPUT); //initializes digital pin 2 as an input
    Serial.begin(9600); //This is the setup function where the serial port is
    initialised,
    attachInterrupt(0, rpm, RISING); //and the interrupt is attached
}
// the loop() method runs over and over again,
// as long as the Arduino has power
void loop ()
{
    floaterTest = digitalRead(floater);

    if (floaterTest == 0) {
        digitalWrite(relay, 0);
        timer = timerTime;
    }
    if ((floaterTest == 1) && (timer == 0)) {
        digitalWrite(relay, 1);
    }
    if (timer > 0) {
        timer = timer - 1;
    }
    NbTopsFan = 0; //Set NbTops to 0 ready for calculations
    sei(); //Enables interrupts
    delay (delayLength); //Wait
    cli(); //Disable interrupts
    Calc = (NbTopsFan / 7.5 * 1000 / realDelayLength); //(Pulse frequency) /
    7.5Q, = flow rate in L/min
    timeNew = millis();
    realDelayLength = (timeNew - timeOld);
    timeOld = timeNew;
}
```

```
Vol = Vol + (Calc + CalcOld) / 2 * realDelayLength / (60e3);

if (timeNew > 10000) {
    seepage = Vol / (timeNew / 1000);

    Serial.print (seepage);
    Serial.print ("\t");
}

Serial.print (Vol, DEC);
Serial.print ("\t");
Serial.print (timeNew);
Serial.print ("\n");
CalcOld = Calc;
}
```

Appendix D - Documentation from initial development

Brainstorm 1: Understanding the problem

Brainstorm to get a common understanding of the problem and lay out the main pain points and concerns.

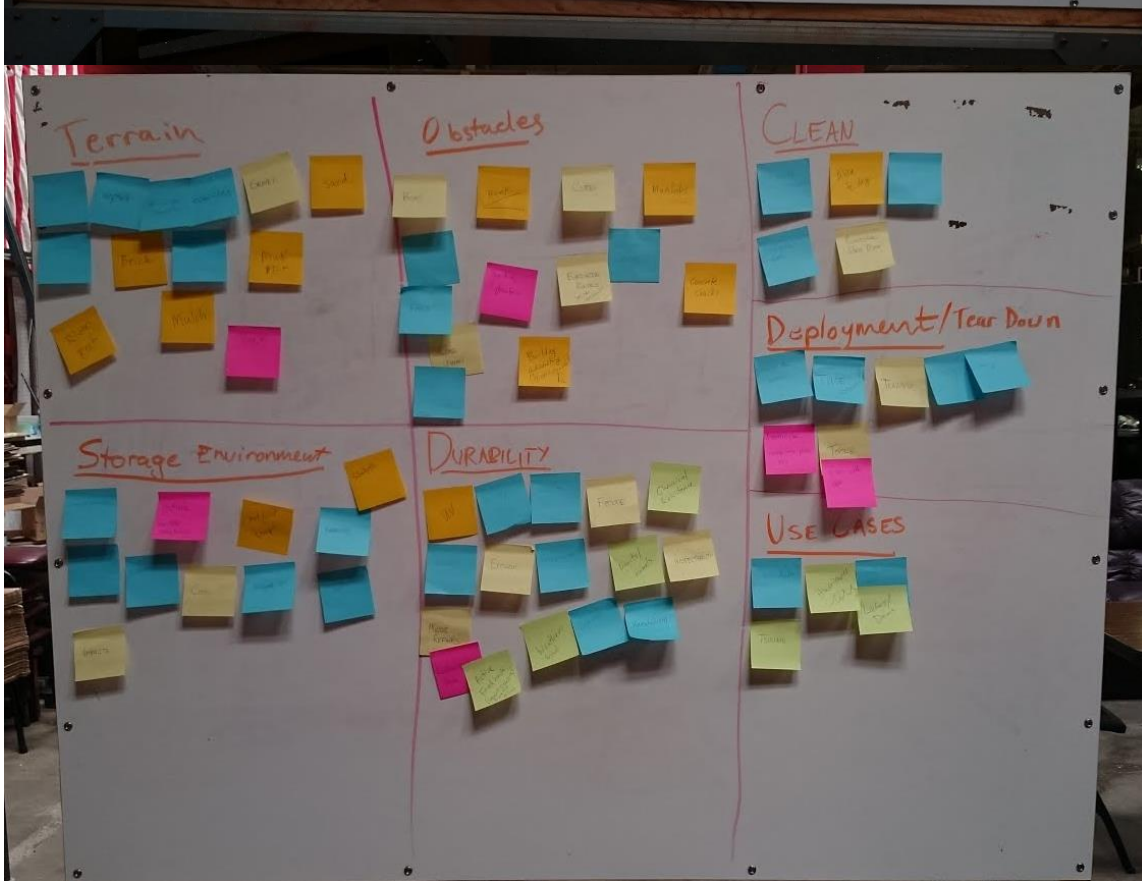
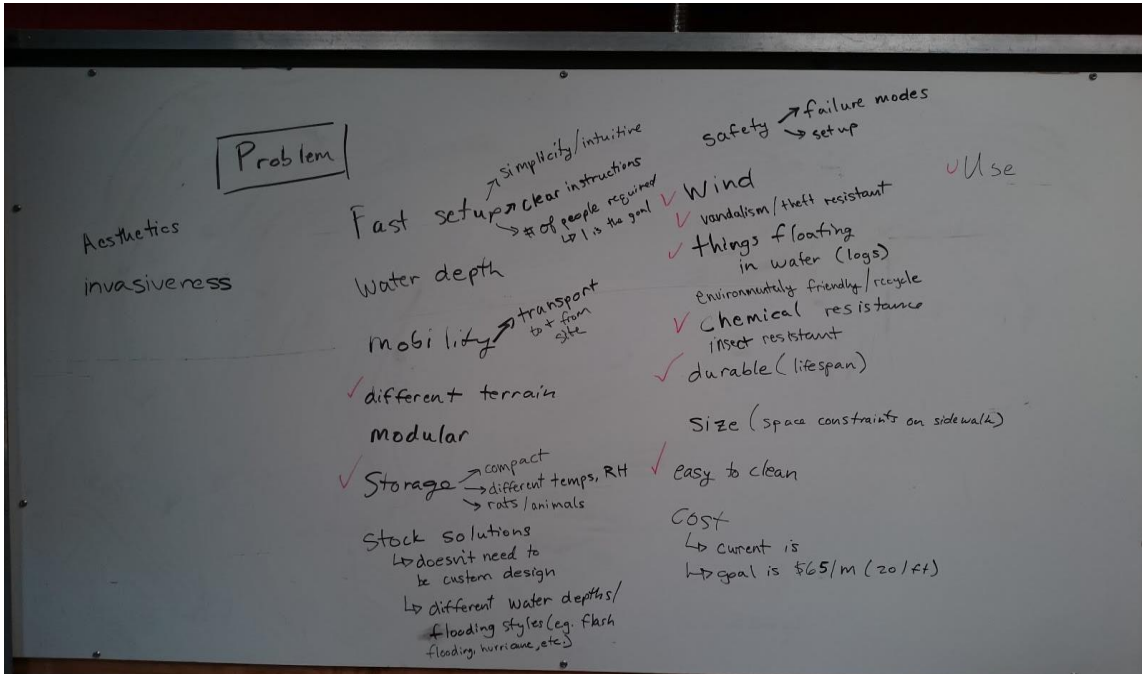

Summary of brainstorm 1:

<p>Terrain</p> <ul style="list-style-type: none"> • Grass • Asphalt • <i>Transition between surfaces</i> • Brick • Cobblestone • Clay • Concrete • Gravel • Mud/dirt • Sand • River rock • Mulch • Slope 	<p>Storage environment</p> <ul style="list-style-type: none"> • Compact product • Outside, variable conditions • Rats/animals • Access (full garage) • Costs • Sunlight/UV • Hot/cold temps • Humidity • Time • Shelves • Impacts 	<p>Obstacles</p> <ul style="list-style-type: none"> • Bushy • Ramp • Curbs • Walls • Fences • Gardens/plants • Evacuation routes • Cars (parked) • Hedge • Building geometry (corners, curves) • Not your building/property • Concrete cracks • Manholes 	<p>Durability</p> <ul style="list-style-type: none"> • UV • Reuse • Impacts • Fatigue • Chemical resistance • Corrosion • Erosion • Disposable • Insects/animals • Inspectability • Minor repairs • Replaceable parts • Active feedback (smart sensors to predict failure) • Weather, wind • Lightning • Vandalism
<p>Deployment/tear down</p> <ul style="list-style-type: none"> • Possible for 1 person • Time, 30 min? • Training • Feedback, snap into place etc. • Tools, included • Cleaning • Storing 	<p>Use cases</p> <ul style="list-style-type: none"> • Flash floods • Hurricanes • Tsunamis • Overflowing rivers • Lakes/dams 	<p>Clean</p> <ul style="list-style-type: none"> • Accessible inside • Able to dry • Hydrophobic • Disposable parts • Functional when dirty 	

Brainstorm 2: ways to protect your property/flood protection concepts

INITIAL CONCEPTS

Concept 1: Security Shutter

Inspiration is taken from security shutters, often found in front of shops after hours. It is flexible and allows bending around one axis while offering high strength and stiffness in the other.



The flexibility is sought after to create modules that easily can accommodate corners and obstacles the flood barriers have to tackle. Another issue this design tries to solve is varying terrain height. It does this by allowing the vertical beams move up and down with respect to each other. The proposed design for the links is shown on the left and a prototype proving the concept is beside it.

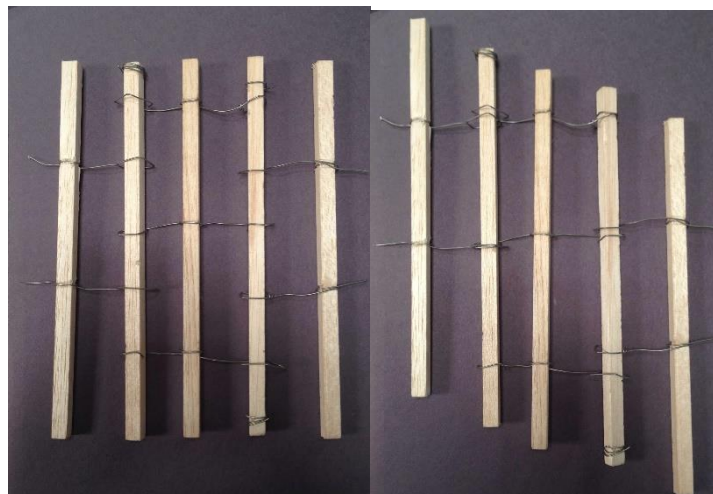
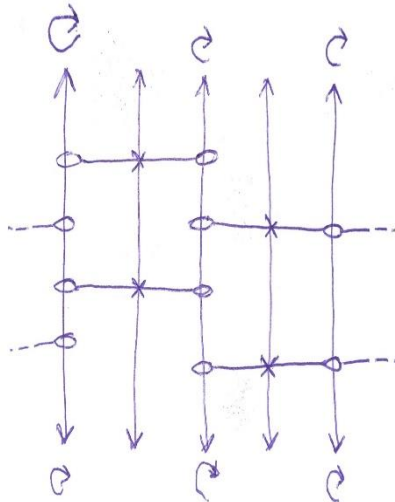

This wall can be implemented in a L-design by the vertical beams transitioning in an angle at contact with the ground. There can however not be any links between the beams to allow bending in the vertical part.

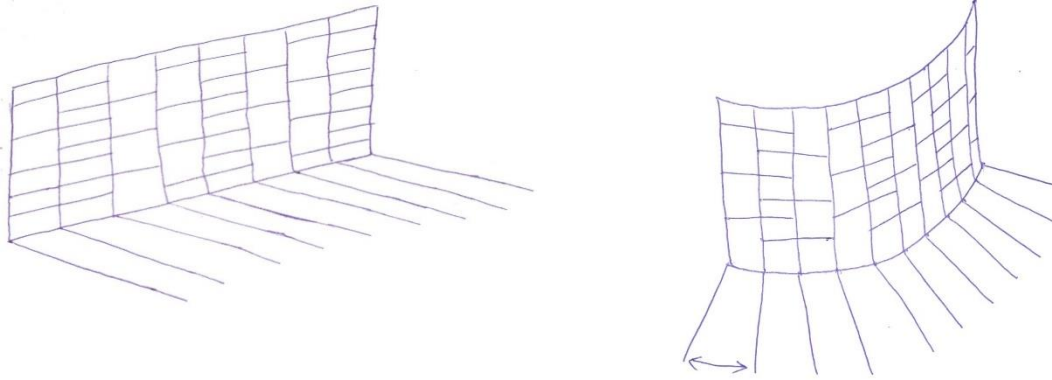

Another solution is by having support posts the modules can attach to. The support posts give stability by one half of the base being submerged by water pushing down on the front and the other half acting as support before the flooding occurs. These posts can also act as a drum that the wall can wrap around during storage and transportation shown with a sketch below on the right.

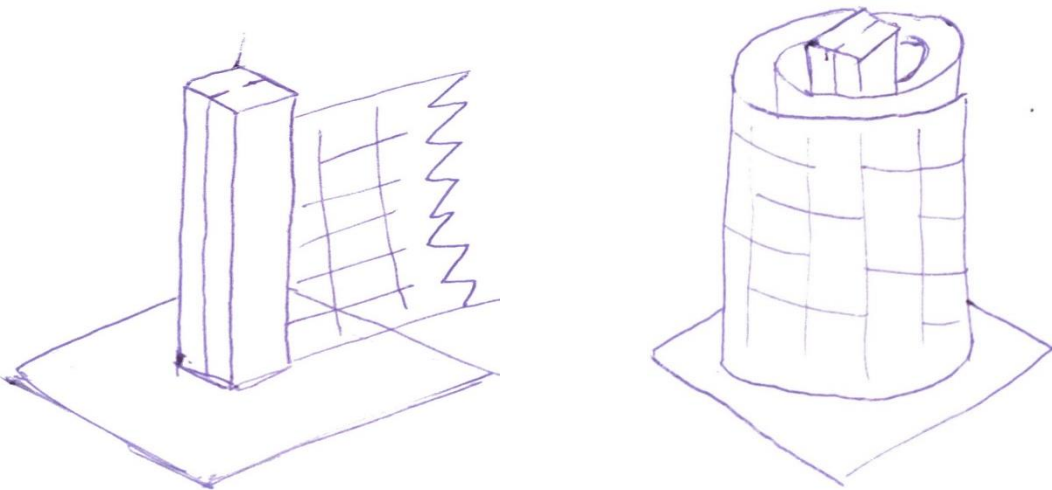

Both of these solutions covers only the structural stability needed for a flood barrier but not the waterproofing aspect of it. One solution to this is dressing the structure with a sheet of waterproof material that is either permanently attached or that is attached after assembly by the user.

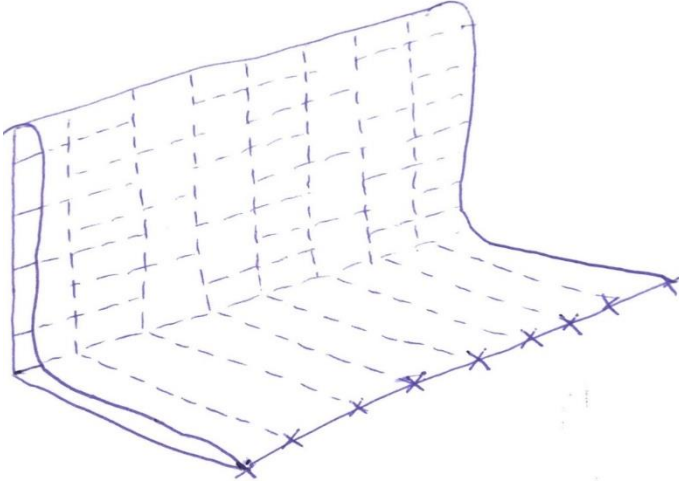

Concept 2: Accordion

Using the concept found in an accordion it is possible to create a sheet that is waterproof and that can vary in length and angle. Triangular supports are connected with an accordion-folded material to create each module of the flood barrier. To the left is the deployed module and to the right is the same module compacted for storage and transportation.

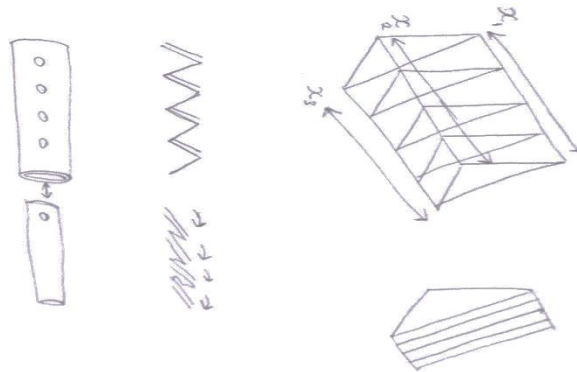

Because this structure is not stable it needs support along x_1 , x_2 and x_3 . By varying the lengths of these three lengths it is possible to have custom lengths and angles of the module. A proposed system is to attach bars that can be varied in length along each of the sides.

To create a good seal against the floor surface the accordion folded material has to lay in such a way that it minimises seepage. One idea is to divide the sheet into two materials. One heavy and rigid material (illustrated by two lines on the figure below) and a flexible material like rubber (one line). The heavy material will fold over the flexible material creating a good seal. An extra option to secure a seal would be having a device that attaches to the end and that can be fastened securely.

Concept 3: Line Dividers (Crowd Control)



Using a similar system AquaFence currently uses but combining it with a length of waterproof fabric between each module to add flexibility of both length and angle, reducing the current system to only one kind of module.

A retractable sheet is permanently connected to one side of the module on a spool. During deployment

the sheet is pulled out to the desired length and desired angle and attached to the next module and the process is repeated.

Concept 4: Tetrahedral structure

“Out-there” concept based on an assembly of numerous of tetrahedral structures to accommodate uneven ground.

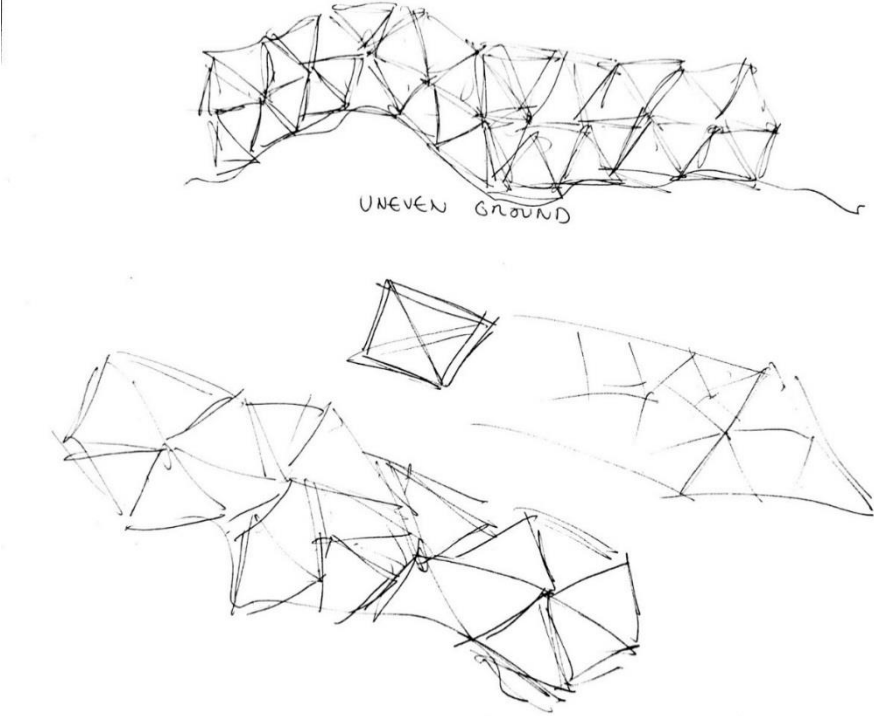

Concept 5: Double spring concept

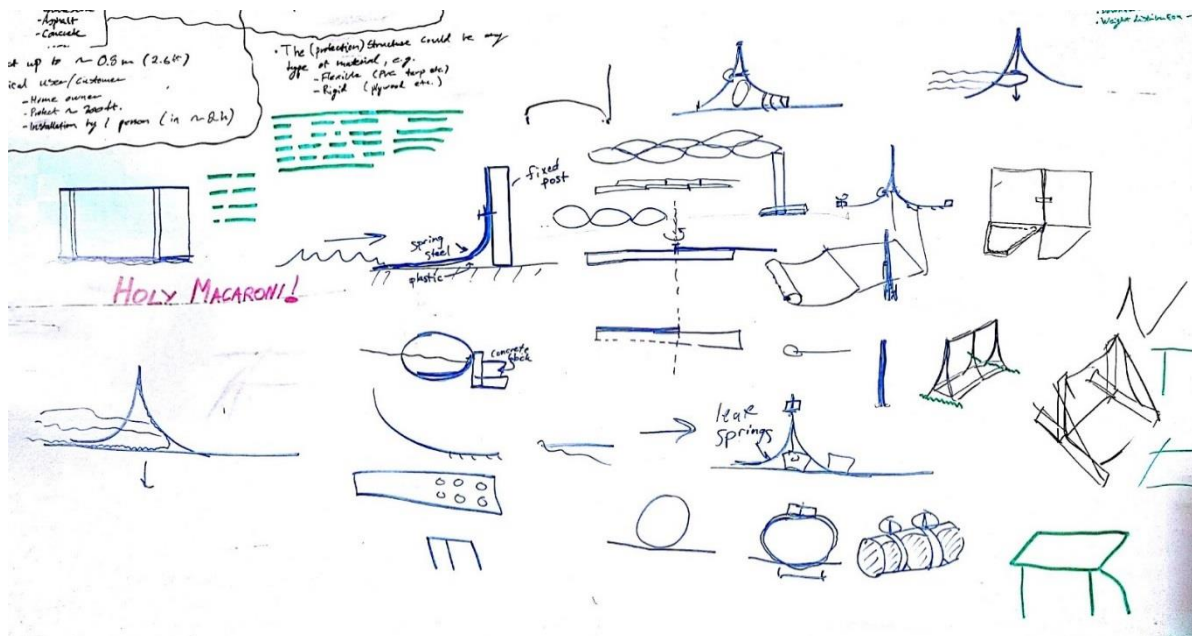

Use leaf-springs (or other material that can act as a spring) with canvas/PVC/flexible material underneath. The essence of the concept is that the spring together with the flexible material will create a good seal against the ground that can accommodate different types of surfaces, including surfaces with variable height.

Sealing concepts:

Hinge/slide mechanism:

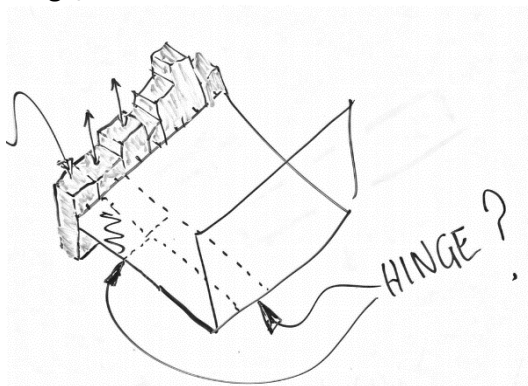

Rubber blocks on end of module. Hinged or with a sliding mechanism. Blocks will place against ground in different heights

Sponge seal:

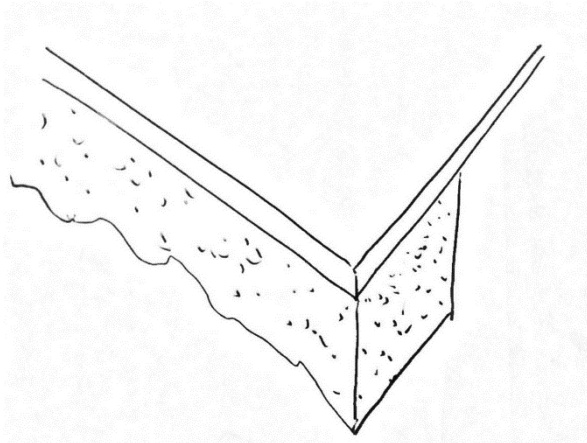

Seal in “waterproof sponge material” (neoprene?). Highly formable material will create a tight seal caused by weight of module and pressure from water.

Power seal:

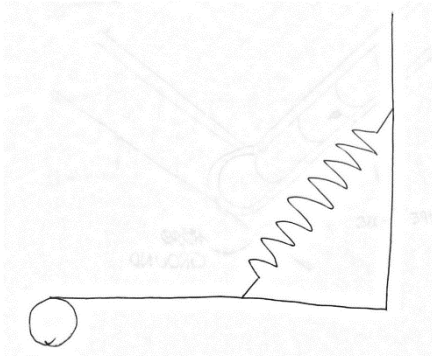

A hinged system with a spring that increases pressure against ground at the tip of the module for a tighter seal.

Inflatable seal

Seal is made of a tube filled with water or air.

Double rubber seal:



Soft square foam:



Soft foam material covering all four edges of the module.

Squeegee:

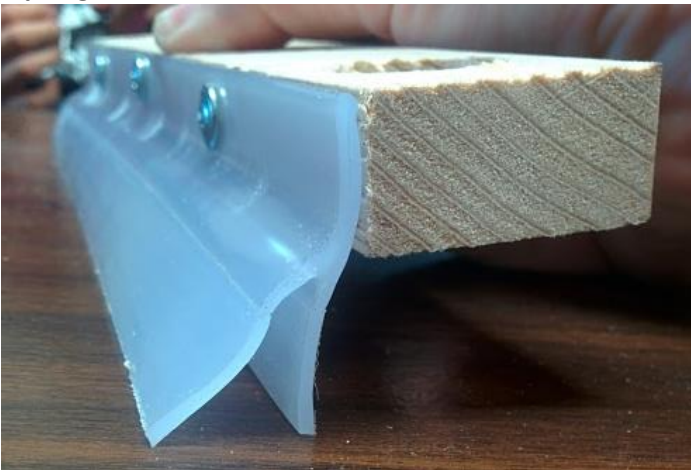

TESTING

Testing of superabsorbent polymer:



Tested superabsorbent polymer to see how well it binds up water and if it will work with seawater (about 35 g/l). Potential application is to absorb water to add ballast to the system and make a seal against the surface.

Findings:

- Promising effect with tap water but does not work with water that has the salt content of seawater

Next steps

- Test polymer embedded in fabric or similar
- Answer q: is it adequate/suitable for sealing off space between structure and ground?

Testing setup 1.0:



Tested two 25x25 cm models with 50 cm plastic canvas in a kiddie-pool.

Purpose:

- See how scale models behave in water
- See how a plastic canvas vs. solid structure behaves

Findings:

- Total failure
- Cardboard and canvas are too light and floats, need more solid and dense materials for testing
- Difficult to get create a working seal against the surface, even with PVA material
- A free-standing canvas is extremely exposed to wind

Next steps:

- Build and test with materials that are more durable and similar to those that could be used in the actual products
- Re-use and modify the pool (if needed)

Test setup 2.0 :

A plywood test tank, to test stability and sealing for different concepts:



An acrylic glass L-module, to test different sealing concepts:

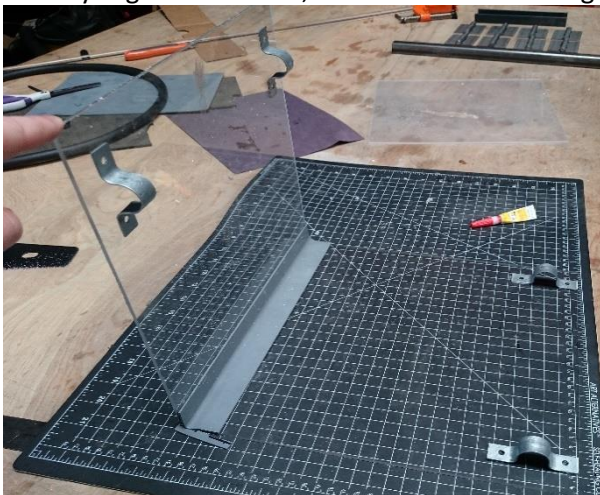

Different surface inserts plates to simulate foundation surface. Made out of “bedliner” and gravel.



Testing in setup 2.0.

Test 1: L-Module without surface plate and sealing



Worked surprisingly well. Only minor seepage was observed with the module, most of the seepage occurred at the sides of the module (our temporary sealing with clay). An effective seal as long as the rubberized wood was dry. Flipping and general stability was an issue when the surface was wet

Test 2: Module with weather-stripping seal (double trouble) without surface plate



Findings:

- Our test setup and prototype seem to work well
 - A mode of failure was detected if a layer of water was allowed to form underneath the module: sliding and flipping
 - Difficult to compare the two tests (no seal vs. seal) on flat, rubbery surface. Does not seem like there are any major differences
 - Major pain points to focus on
-

-
- Surface. Important to test different surfaces that mimic those encountered in real-life scenarios. Rubberized plywood is far from that
 - Considerably better than test 1, but still a lot of seepage on both rubber surface and medium bedliner(not thick enough). No tipping or other modes of failure
-

Test 3: Acrylic L-Module with weatherstripping seal (double trouble) on semi-rough bedliner surface:



Findings:

- Surface seem to represent a real-life scenario
 - Double trouble was not able to seal against the surface, most likely too low sealing. However, the sealing was good enough to build up a significant difference in water level
 - Pain points and next steps:
-

-
- Test other surfaces (finer, coarser, grass etc.)
 - Test custom-made types of sealing
 - Test with more realistic weight. A module this size should probably weigh around 2 - 5 kg
 - Investigate significance of weight distribution, could a completely different shape (other than L) be advantageous?

Test 4: Foam sheet base, square and horseshoe

Attached a foam sheet to the base of the test module. Tested to configurations: Square with hole in centre (left) and the horseshoe (right), the same square with a part cut out on the far side.



Findings

- Tested initially without extra weight on the module. The whole base of the module ended up floating and therefore breaking the seal with the ground. Because of this the next tests were performed with weights placed on the module.
- Square results: There was moderate leaking and low pressure holding the module down. This could be because water that leaks under the module is built up and trapped in the square that is cut out of the foam sheet and this creates a pressure underneath. The horseshoe should remove this problem
- Horseshoe: As predicted the module stuck to the base as the water that leaked through under the module is able to flow away and prevent pressure building up underneath. There was leaking but at an acceptable rate.
- Based on the testing it is concluded that the horseshoe shape is superior to the enclosed square
- Our assumptions that water could get trapped under the module and cause it to flip over was confirmed
- The horseshoe solution allows excess water to flow out behind the module, eliminating flipping

Test 5: Soft foam block - medium bedliner



As expected, no low-pressure zones were allowed to developed and the entire module ended up flipping over.

Test 5: Initial superabsorbent polymer distributed in a plastic bag:



Findings:

- The superabsorbent polymer expanded more than anticipated and we probably used too much for the size of the sealing (about 15 grams powder)
- Very promising effect, the expansion elevated the module despite of being fixed with clay along the edges and the water pressure forcing it down
- Pain points and next steps:
 - Optimize powder to water ratio (gut-feeling: about 20 grams for 1 meter, 2 kg for 100 m, total cost 90 \$ from amazon)
 - Test different concepts of and designs (c-shaped, edge-balloon etc.)
 - Investigate using a canvas in combination with superabsorbent polymer

Test 6: Superabsorbent polymer in fabric tube 1.0



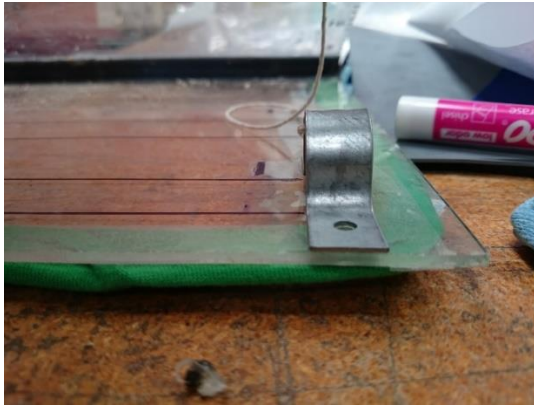



A cloth tube (old t-shirt) was filled with superabsorbent polymer (17 g). The tube was 95 cm long and made out of a 6 cm wide cut-out. Double-sided tape was used both to create the tube and fix it to the module.

Findings

- The polymer expanded as planned and worked well as a seal
- Too much powder was used (again)
- Most of the seepage seemed to occur in the corners of the tube (this could be eliminated with a more complex/higher resolution prototype)
- There was very little seepage with higher water levels
- Pain points and things to test
 - More rounded corners
 - Less powder
 - More durable tube to avoid collapse of tube (and possibly the entire module)
 - Allow the superabsorbent polymer to absorb water before the water level rises significantly. This should allow the material to swell and create a seal before being flooded

Test 7: Superabsorbent polymer in fabric tube 2.0

Improved version of the previous test. 10 g of powder was used (vs. 17 in the last test) and the following things were improved:

- increased radius of corners to avoid sharp, warped corners
 - gorilla tape in addition to the double sided tape to make the tube stronger to avoid rupture
-



Almost fully sealed at max water height.

Test 8: Superabsorbent polymer in fabric tube 3.0

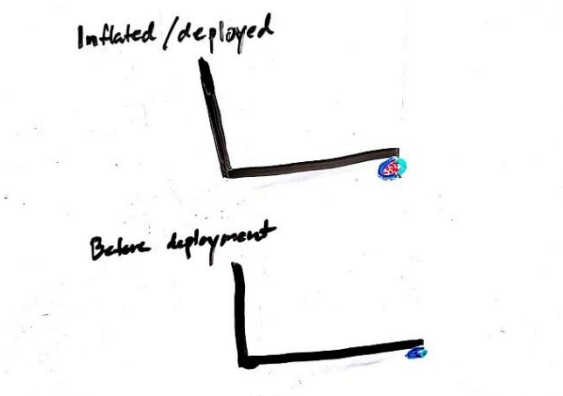
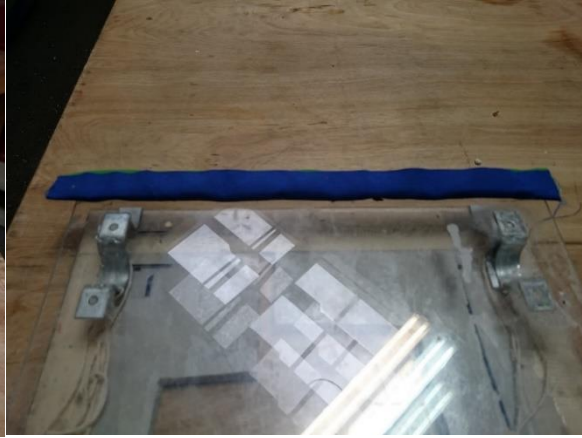
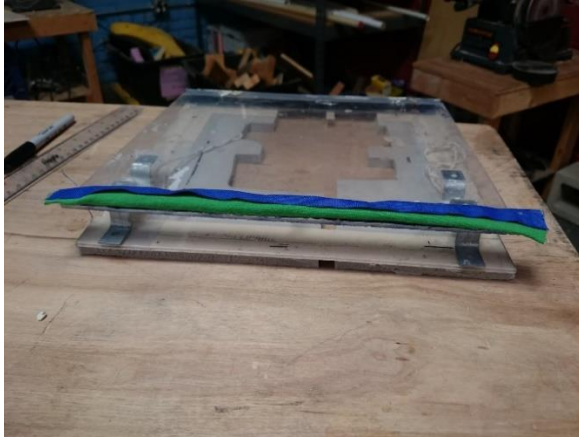

Building and test of C-shape with superabsorbent polymer. This is a design that came up in a brainstorm one of the first days. The C-shape is made from the PVC-coated polyester fabric (the C-shape) and cloth (the front). The idea is that the module will lay flat before the deployment and that it will absorb water and inflate once water reaches the front and gets absorbed by the superabsorbent polymer.

Findings

- Superabsorbent polymer works extremely well, once again
- The seal managed to achieve minimal seepage despite being a very rough prototype:

-
- Using a glue gun made the upper and lower parts a lot stiffer and rigid than desired
 - The PVC-coated polyester is stiffer and less flexible than desired, especially for the scale that we are working on
-

Test 9: Without seal on medium bedliner



Findings:

- The module obviously leaks a lot, but the main mode of failure is that the module is prone to tipping over when the pressure underneath the base is equalized

Test: without seal on medium bedliner - with extra ballast



Findings

- The added weight helps reduce the tipping
- The pressure underneath the module drops significantly when the water is allowed to flow freely (Bernoulli) + avoiding accumulation of water

Seal against ground

Test 10: Double spring concept rapid prototyping and testing



Despite being tested only on rubberized plywood, it seems that the double spring solution has potential to create a good seal. It does however seem to have worse load handling properties than an L-structure.

Test 10: Ice-block and building foam



Appendix E - Risk assessment form

The risk assessment form starts on the next page.

NTNU		Kartlegging av risikofylt aktivitet		Utarbeidet av		Nummer		Dato	
				HMS-avd.		HMSRV2601		03.02.2016	
HMS				Godkjent av				Erstatter	
				Rektor				01.12.2006	

Enhet: Department of engineering design and materials

Linjeleder:

Deltakere ved kartleggingen (m/ funksjon): Torgeir Welo, veileder/ Kristian Vemund Haaland, student/Øystein S. Blix Walderhaug, student
(Ansv. veileder, student, evt. medveiledere, evt. andre m. kompetanse)

Kort beskrivelse av hovedaktivitet/hovedprosess:

Prosjektoppgave student. Kristian Vemund Haaland og Øystein S. Blix Walderhaug
Utvikling av testrig og produktkonsepter av flomvern

Er oppgaven rent teoretisk? (JA/NEI): Nei

risikovurdering. Dersom «JA»: Beskriv kort aktiviteteten i kartleggingskjemaet under. Risikovurdering trenger ikke å fylles ut.
«JA» betyr at veileder innestår for at oppgaven ikke inneholder noen aktiviteter som krever

Signaturer: Ansvarlig veileder: Torgeir Welo



Student: Kristian Vemund Haaland og Øystein S. Blix Walderhaug
 

Dato: 2016.02.03

ID nr.	Aktivitet/prosess	Ansvarlig	Eksisterende dokumentasjon	Eksisterende sikringstiltak	Lov, forskrift o.l.	Kommentar
1	Bruk av maskinverksted	KVH/ØBW	Romkort	Romkort		
1a	Bruk av roterende maskineri	KVH/ØBW	Maskinens brukermanual	Ukjent	Ukjent	
1b	Bruk av laserkutter	KVH/ØBW	Maskinens brukermanual	Ukjent	Ukjent	
1c	Bruk av 3D printer	KVH/ØBW	Maskinens brukermanual	Ukjent	Ukjent	
1d	Bruk av skjæreverktøy	KVH/ØBW	Ukjent			
1e	Bruk av sammenføyningsmidler (lim og lignende.)	KVH/ØBW	Produktets brukermanual og datablad	Datablad	Ukjent	

NTNU



HMS

Kartlegging av risikofyllt aktivitet

Utarbeidet av	Nummer	Dato
HMS-avd.	HMSRV2601	03.02.2016
Godkjent av		Erstatter
Rektor		01.12.2006



2	Tilstedeværelse ved arbeid utført av andre.	Andre	Andres HMSRV2601	Andres HMSRV2601	Prosessavhengig
3	Eksperimentelt arbeid	KVH/ØBW	Egen risikovurdering- må gjøres for hvert enkelt eksperiment		Prosessavhengig

Risikovurdering

 Utarbeidet av
 HMS-avd.
 Godkjent av
 Rektor

 Nummer
 HMSRV2601

 Dato
 03.02.2016
 Erstatler
 01.12.2006

ID nr	Aktivitet fra kartleggings-skjemaet	Mulig uønsket hendelse/belastning	Vurdering av sannsynlighet (1-5)	Vurdering av konsekvens:				Risiko-Verdi (menneske)	Kommentarer/status Forslag til tiltak
				Menneske (A-E)	Ytre miljø (A-E)	Øk/materiell (A-E)	Om-dømmes (A-E)		
1	Bruk av maskinverksted								
1a-i	Bruk av roterende maskineri	Stor kuttskade	2	D	A	A	D	2D	Sørg for at roterende deler er tilstrekkelig sikret/dekket. Vær nøye med opplæring i bruk av maskineri.
1a-ii		Liten kuttskade	3	B	A	A	A	3B	Vær nøye med opplæring i bruk av maskineri. Ikke ha løse klær/tilbehør på kroppen.
1a-iii		Klemskade	2	D	A	A	C	2D	Vær nøye med opplæring i bruk av maskineri. Ikke ha løse klær/tilbehør på kroppen.
1a-iv		Flygende spon/gjenstander	3	C	A	A	B	3C	Bruk øyevern og tildekk hurtig roterende deler (Fres og lignende.)
1a-v		Feil bruk-> ødelagt utstyr	3	A	A	C	A	3C	Vær nøye med opplæring i bruk av maskineri
1b-i	Bruk av laserkutter	Klemskade	2	D	A	A	C	2D	Vær nøye med opplæring i bruk av maskineri. Ikke ha løse klær/tilbehør på kroppen.
1b-ii		Brannskade	3	B	A	A	A	3B	Vær nøye med opplæring i bruk av maskineri. Bruk hansker ved håndtering av varme materialer.

Risikovurdering

Utarbeidet av
HMS-avd.
Godkjent av
Rektor

Nummer

HMSRV2601

Dato

03.02.2016

Erstatter

01.12.2006



1b-iii	Øyeskade-laser	2		D		A		A		A		C	2D	Bruk øyevern! Skru av laser når maskinen ved oppsett.
1b-iv	Brann	2		B		A		D		A		C	2B	Vær nøye med opplæring i bruk av maskin. Ha slukkeutstyr tilgjengelig
1c-i	Bruk av 3D-printer	3		B		A		A		A		A	3B	Vær nøye med opplæring i bruk av maskin.
1c-ii	Innhalering av plast/ printemateriale	5		A		A		A		A		A	5A	Bruk åndedrettsvern/ vernebriller
1c-iii	Feil bruk-> ødelagt maskineri	3		A		A		C		A		A	3A	Vær nøye med opplæring i bruk av maskin.
1d-i	Bruk av skjæreverktøy	2		D		A		A		A		D	2D	Bruk skapre verktøy og riktig skjæreunderlag
1d-ii	Liten kuttskade	3		B		A		A		A		A	3B	Bruk skapre verktøy og riktig skjæreunderlag
1e-i	Bruk av samenføyingsmidler (lim og lignende.)	2		D		A		A		A		B	2D	Bruk øyevern, ha datablad tilgjengelig
1e-ii	Eksponering hud	3		A		A		A		A		A	4A	Bruk hansker, ha datablad tilgjengelig
1e-iii	Eksponering åndedrett	3		A		A		A		A		A	4A	Bruk åndedrettsvært/ god ventilasjon. Ha datablad tilgjengelig.

NTNU



HMS

Risikovurdering

 Utarbeidet av
 HMS-avd.
 Godkjent av
 Rektor

 Nummer
 HMSRV2601

Dato

03.02.2016

Erstatter

01.12.2006



1e-iv	Søl	3	A	B	A	A	A	4A	Ha papir/ rengjøringsmaterieill tilgjengelig. Ha datablad tilgjengelig.
2	Tilstedeværelse ved arbeid utført av andre.	3	C	C	C	C	C	3C	Hold et øye med hva som foregår rundt deg.
3-i	Eksperimentelt arbeid	1	A	A	A	A	D	1E	Unngå å jobbe alene
3-ii	Elektrisitet- strøm	1	A	A	A	A	A	3V	Typisk lite energi involvert. Bruk isolerte verkøty

NTNU	Risikovurdering			Utarbeidet av	Nummer	Dato
				HMS-avd.	HMSRV2601	03.02.2016
HMS				Godkjent av	Erstatter	
				Rektor		01.12.2006



Sannsynlighet vurderes etter følgende kriterier:

Svært liten 1	Liten 2	Middels 3	Stor 4	Svært stor 5
1 gang pr 50 år eller sjeldnere	1 gang pr 10 år eller sjeldnere	1 gang pr år eller sjeldnere	1 gang pr måned eller sjeldnere	Skjer ukenlig

Konsekvens vurderes etter følgende kriterier:



Gradering	Menneske	Ytre miljø Vann, jord og luft	Øk/materiell	Omdømme
E Svært Alvorlig	Død	Svært langvarig og ikke reversibel skade	Drifts- eller aktivitetsstans > 1 år.	Troverdighet og respekt betydelig og varig svekket
D Alvorlig	Alvorlig personskade. Mulig uførhet.	Langvarig skade. Lang resitusjonstid	Drifts- eller aktivitetsstans i opp til 1 år	Troverdighet og respekt betydelig svekket
C Moderat	Alvorlig personskade.	Mindre skade og lang resitusjonstid	Drifts- eller aktivitetsstans < 1 mnd	Troverdighet og respekt svekket
B Liten	Skade som krever medisinsk behandling	Mindre skade og kort resitusjonstid	Drifts- eller aktivitetsstans < 1 uke	Negativ påvirkning på troverdighet og respekt
A Svært liten	Skade som krever førstehjelp	Ubetydelig skade og kort resitusjonstid	Drifts- eller aktivitetsstans < 1 dag	Liten påvirkning på troverdighet og respekt

Risikoverdi = Sannsynlighet x Konsekvens

Beregn risikoverdi for Menneske. Enheten vurderer selv om de i tillegg vil beregne risikoverdi for Ytre miljø, Økonomi/materiell og Omdømme. I så fall beregnes disse hver for seg.

Til kolonnen "Kommentarer/status, forslag til forebyggende og korrigerende tiltak":



Tiltak kan påvirke både sannsynlighet og konsekvens. Prioriter tiltak som kan forhindre at hendelsen inntreffer, dvs. sannsynlighetsreduserende tiltak foran skjerpet beredskap, dvs. konsekvensreduserende tiltak.

NTNU	Risikomatrixe			utarbeidet av	Nummer	Dato
				HMS-avd.	HMSRV2604	03.02.2016
HMS/KS	godkjent av		Erstatter			
	Rektor		09.02.2010			

MATRISSE FOR RISIKOVURDERINGER ved NTNU

KONSEKVENSENS		E1	E2	E3	E4	E5
		D1	D2	D3	D4	D5
Svært alvorlig		C1	C2	C3	C4	C5
Alvorlig		B1	B2	B3	B4	B5
Moderat		A1	A2	A3	A4	A5
Liten		Svært liten	Liten	Middels	Stor	Svært stor
Svært liten		SANNSYNLIGHET				

Prinsipp over akseptkriterium. Forklaring av fargene som er brukt i risikomatrixen.

Farge	Beskrivelse
	Uakseptabel risiko. Tiltak skal gjennomføres for å redusere risikoen.
	Vurderingsområde. Tiltak skal vurderes.
	Akseptabel risiko. Tiltak kan vurderes ut fra andre hensyn.

