

MASTER THESIS:

**LEVERAGE EFFICIENCY WITH
OPTIMISED INFORMATION
SECURITY COMMUNICATION**

AUTHOR: KJETIL SVEEN

Date: 1 June 2016

ABSTRACT OF MASTER THESIS

Title:			Date: 01.06.16
	<u>Leverage efficiency with optimised information security communication</u>		
Participants:	<u>Kjetil Sveen</u>		
Supervisor(s)	<u>Bernhard Hämmerli</u>		
Employer:	<u>N/A</u>		
Keywords (3-5)	<u>Information security, human aspects, communication, rhetoric, persuasion</u>		
Number of pages: 118	Number of appendix: 1	Availability (open/confidential): open	
Short description of the master thesis:			
<p>Information security is a multidisciplinary area of study and professional activity. It comprises technical, organisational, human and legal issues, and requires thus cooperation between professionals and individuals with very different background and education. Cooperation that spans over such a wide area will experience challenges when it comes to communication and mutual understanding. Efforts to improve information security will therefore be heavily influenced by the security professional's ability to communicate efficient to a very diverse audience. This thesis address this issue. Through the study of different communication models, communication theories and literature from different areas of practice and research there are identified several factors that influence communication efficiency. A selection of these factors are considered as useful for communication optimisation. These factors are visualised into a model called Metacom. This model also serve as a framework to integrate optimisation techniques from different sources.</p> <p>Important contribution of this master thesis will be increased attention and understanding of the importance of optimised communication within the discipline. The insights provided will show how security professionals can utilise knowledge from other disciplines as tools to enhance their communication performance and thereby strengthen information security.</p>			

Management summary

Information security is a multidisciplinary area of study and professional activity. It comprises technical, organisational, human and legal issues, and requires thus cooperation between professionals and individuals with very different background and education. Cooperation that spans over such a wide area will experience challenges when it comes to communication and mutual understanding.

The information security professional must hold deep expertise within his discipline. He must understand complex and abstract issues. To mitigate the risk he will often need to cooperate with other humans. This could be to raise money for new security measures, get support for new policies or influence the security culture within the company. His efforts to improve information security will be heavily influenced by the security professional's ability to communicate efficient to a very diverse audience. Optimised information security communication is therefore a very important topic.

There seem to be little research literature available from databases as ACM, IEEE Xplore Digital Library and Springer Link that discuss the quality aspects of human communication on information security. Yet, the importance of the subject is emphasised in topics like "IMT4132 - IT Rhetoric for Security Risk Management" by Professor Stewart Kowalski, and "IMT4671 - Organizational, and Human Aspects of Information Security" by Professor Bernhard Hämmerli at Norwegian University of Science and Technology. These topics also provided useful theories and practises as a basis for this project, which aim to leverage efficiency with optimised information security communication.

This research project has investigated different communication models, communication theories and literature from different areas of practice and research in order to identify factors that influence communication efficiency. The analysis from these data sources also elicit optimisation techniques that can be used to influence the different factors. Different use cases from human communication on information security were used to identify some central properties of such communication. A small selection of use cases that represent these properties were then analysed based on the identified optimisation factors. This analysis illustrated the need to optimise information security communication for different target groups.

The analysis of data source and use cases were used to select a set of factors that are considered as useful for communication optimisation. These factors and their relationship were visualised into a model called Metacom. The factors and the model were developed through an iterative process. Metacom is proposed as a model useful to optimise information security communication. The proposed Metacom model address both strategic and tactical communication optimisation. It points out how a long-term perspective on

communication will amplify the effect, in addition to the efficiency that is obtained through short-term context specific optimisation. The model is also considered suitable to structure and integrate communication optimisation techniques from different areas of practice and research.

This research do not consider technical problems related to communication. Factors that influence the efficiency of human communication is studied by several fields of research outside the discipline information security. The study within this thesis seek to apply information from other fields of research based on a general and pragmatic approach. To make the scope manageable it does not consider every possible aspects and details related to human communication on information security. Consequently, there will exist several issues related to these topics that deserves a closer inquiry through further work.

Important contribution of this master thesis will be increased attention and understanding of the importance of optimised communication within the discipline of information security. The insights provided show how security professionals can utilise knowledge from other disciplines as tools to enhance their communication performance and thereby strengthen information security.

Acknowledgements

Foremost I would like to thank my supervisor Professor Bernhard Hämmerli for his guidance and support through the research and writing of this thesis. His mentoring, advice, inspiration and contributions have been invaluable through this project, and during the two years on the master program at NTNU in Gjøvik. Bernhard's capacity as a well-informed professional and a decent professor makes him the best possible supervisor.

I would also like to express my gratitude to the rest of the professors and the lectures at the master program. Their knowledge and experience have contributed to professional development beyond my expectations. Related to this thesis I would particularly emphasise the topics "IMT4132 - IT Rhetoric for Security Risk Management" by Professor Stewart Kowalski, and "IMT4671 - Organizational, and Human Aspects of Information Security" by Professor Bernhard Hämmerli.

Administrative support is especially important for an off-campus student and the service from student advisor Hilde Bakke has been excellent.

Finally yet importantly, I would like to thank my wife Monica for her love, wisdom beyond words and for making my master program possible.

Kjetil Sveen

Contents

Management summary	iii
Acknowledgements	v
Contents	vi
List of figures	viii
List of tables	ix
1 Introduction	1
1.1 Topic covered by the project	1
1.2 Keywords	1
1.3 Problem description	1
1.4 Justification, motivation and benefits	2
1.5 Research questions	3
1.6 Limitations	3
1.7 Claimed contributions	3
1.8 Thesis outline	4
2 Choice of methods	5
2.1 Overview	5
2.2 Literature review	6
2.3 Creativity	7
2.4 Case studies	7
2.5 Analysis and logical reasoning	7
2.6 Verification	7
3 Related work	8
3.1 Defining communication	8
3.2 The purpose of communication	10
3.3 Factors that influence communication	10
3.4 Communication models	12
3.4.1.1 Aristotle’s communication model	12
3.4.2 Lasswell’s communication model	12
3.4.3 Shannon and Weaver’s communication model	13
3.4.4 Schramm’s communication model	14
3.4.5 Riley & Riley’s communication model	15
3.4.6 The Johari Window Model	16
3.4.7 The AIDA Model	17
3.5 Propaganda	18
3.5.1 A general introduction to propaganda	19
3.5.2 The use of propaganda in the Third Reich	22
3.6 Persuasion	27
3.6.1 Aristotle’s rhetoric	28
3.6.2 Influence through social psychology	31

3.7	Other factors of the effectiveness problem.....	32
3.7.1	Motivation.....	32
3.7.2	Connection.....	34
3.7.3	Pragmatic human relations.....	36
4	Analysis of communication factors.....	38
4.1	Analysis of communication models.....	38
4.2	Important insight from communication models.....	39
4.3	Mental model for communication optimisation (Metacom).....	44
4.4	Analysis of propaganda for public relation (PR).....	50
4.5	Analysis of Aristotle’s rhetoric.....	53
4.6	Analysis of influence through social psychology.....	55
4.7	Analysis of motivation.....	55
4.8	Analysis of connection.....	56
4.9	Analysis of pragmatic human relations.....	57
4.10	Analysis support with focus layers.....	57
4.10.1	The technical problem.....	58
4.10.2	The semantic problem.....	59
4.10.3	The effectiveness problem.....	59
4.11	Communication success criteria.....	59
4.11.1	Factors contribution to communication efficiency.....	60
5	The importance of communication in information security.....	61
5.1	Information security communication strategy.....	61
5.2	Communication – a tool to make an impact.....	63
5.3	Communication of ideas.....	65
5.4	Communication in information security.....	67
6	Analysis of communication behaviour and improvement.....	69
6.1	Communication use cases.....	69
6.1.1	Use case descriptions.....	69
6.1.2	Analysis of properties for the use cases.....	75
6.1.3	Assessment of communication challenges.....	78
6.1.4	Target groups (Receivers).....	79
6.2	Analysis of use cases with selected target groups.....	80
6.2.1	Analysis method and specification of communication purposes.....	80
6.2.2	Analysis of use cases with Metacom.....	81
6.2.3	Summary of use case analysis.....	87
6.3	Properties of information security communication.....	87
7	Tools for optimised information security communication.....	89
7.1	General.....	89
7.2	The fast track optimisation.....	91
7.3	Further optimisation tools.....	91
7.4	Three key insights.....	93
8	Future work.....	94
9	Conclusion.....	95
	Bibliography.....	96
	Appendix 1 – Example of connecting optimisation techniques from different sources to factors in Metacom.....	99

List of figures

Figure 01: Illustration of Aristotle’s communication model by Sveen.....	12
Figure 02: Illustration of Lasswell’s communication model by Sveen.....	12
Figure 03: Shannon and Weaver’s communication model from [13].....	13
Figure 04: Schramm’s communication model 2 (1954) from [17].....	14
Figure 05: Schramm’s communication model 3 (1954) from [17].....	15
Figure 06: The Rileys’s communication from [19]	15
Figure 07: The Johari Window from [21].....	16
Figure 08: Visualisation of the AIDA model from [23]	17
Figure 09: Simple communication model with channels and feedback.....	39
Figure 10: The communication chain with noise.....	40
Figure 11: Common reference area.....	41
Figure 12: Relationship between sender and receiver.....	41
Figure 13: Communication problems to overcome (visualisation of Weaver problem levels in [15]).....	42
Figure 14: Mental model for communication optimisation (Metacom) by Sveen 2016.....	44
Figure 15: Example of analysis support with focus layers	58
Figure 16: Simple communication model.....	63
Figure 17: The Sender has a mental image (an idea).....	65
Figure 18: The Receiver has received the Message	65
Figure 19: The Receiver has the same mental image as the Sender	66
Figure 20: The Receivers further action determine if the communication has been successful	66
Figure 21: CSIRT communication with outside parties from [43]	68
Figure 22: The Relationship and communication interaction	90
Figure 23: Aristotle’s rhetoric from [11] visualised by Sveen.....	91
Figure 24: Creation of Metacom and mapping of optimisation factors	92

List of tables

Table 1: Outline for the thesis.....	4
Table 2: The Trinity Model of human needs from [35]......	33
Table 3: Summary of the use cases	77

1 Introduction

1.1 Topic covered by the project

This thesis "leverage efficiency with optimised information security communication" will study human and organisational aspects of communication about information security.

1.2 Keywords

Information security, human aspects, communication, rhetoric, persuasion

1.3 Problem description

Information security is a multidisciplinary area of study and professional activity. It comprises technical, organisational, human and legal issues and requires thus cooperation between professionals and individuals with very different background and education. Cooperation that spans over such a wide area will experience challenges when it comes to communication and mutual understanding.

Today information security is important to both organisations and individuals everywhere. Further, it is a well-known fact that security is not just some technical solutions that can be bought. The humans and organisations that surround the technical security solutions influence the achieved security largely. Careless or ignorant human behaviour may render the technical security measures useless. Therefore, it is necessary to consider an overall approach to improve security.

Professionals in the area of information security need to understand and deal with the impact of the human factor in all aspects of their work. The security level will never be constant over a period. A continuous effort to keep the security at an appropriate level involves many forms of human communication. The security professionals must communicate with a wide variation of humans with the aim to raise the security level. To obtain this goal they must be able to persuade or motivate other people to care for security and take proper actions. The tool to achieve this is communication.

Since most people are able to speak, listen, write and read it is easy to assume that they master this tool. When a person believes he master a tool, it often blocks further development. The focus on improvement will not be directed towards the communication skills; after all, he already knows how to communicate. By considering the importance of communication for information security professionals when dealing with human aspects of security, this assumption should not be left without further inquiry. Communication is an advanced tool with many properties. To be able to use this tool in a goal-oriented manner the different properties must be examined.

To utilise communication as a tool to improve the overall security, a professional must be able to adapt the use according to the situation. By analysing different aspects of information security communication and related human aspects, it should be possible to make recommendations for how to approach this goal.

1.4 Justification, motivation and benefits

Communication on information security is not a new topic. After internet became ubiquitous, most people in the developed world uses some kind of computer device [1]. Consequently, the topic of information security became relevant for a huge diverse group of people. Simultaneously have the topic also been increasingly present in the media. The communication about information security is used by different entities for different purposes.

For information security professionals, communication could be used as a tool to influence people in a way that strengthen the information security. There are several situations where the communication constitutes a very important factor. Some examples could illustrate this. When there is a need to raise funds to implement new and better security measures, the information security professional must convince the management that this is a sensible investment. In other circumstances the information security professional need to argue for investment in security within a project group. Communication is also used to educate employees on the company's information security policy. Awareness campaigns aimed at the end users is yet another example.

When communication is such an important tool, it is important to be able to use it effectively. To be able to achieve this it is necessary to have good knowledge about factors that influence this communication. The examples above shows that communication is used for unequal purposes against various target groups. Because people are different, they are motivated by diverse means. Therefore, the communication tool must be tuned according to the situation.

Due to the variations in purposes, target groups and circumstances, it is not practical to make a recipe on how to handle every communication situation. This thesis aims to highlight important aspects of different communication challenges that are relevant to be aware of for an information security professional. Base on this there will be made some recommendations on how to communicate about information security to different target groups.

The goal is to make information security professionals aware of the fact that communication could be one of their most powerful tools. Further that they need to be conscious about important aspects that might influence the effectiveness of their communication. Instead of regarding communication as a tool, it could be useful to look at it as a collection of tools in a tool kit. The appropriate tools should be applied according to the situation. This thesis aims to establish a knowledge base that makes the reader able to choose the most suitable tools for improving their communication. An increased understanding of communication and enhanced communication skills will empower the information security professional and thus strengthen the information security.

It is assumed that the efficiency of information security could be increased by 50-100% with optimised information security communication. To perform a measurement of communication efficiency is considered a too big task for this project. The topic is therefore suggested as further work in a later master thesis.

1.5 Research questions

The research questions defined in this section sets the focus for this study on communication on information security. The questions under investigation are these:

- 1 How can information security communication be optimised against target groups?
 - 1.1 Which factors are important when communication shall be optimised?
 - 1.2 Which criteria determine the quality of the communication?
 - 1.3 Which recommendations could be given based on the factors and criteria?

1.6 Limitations

This thesis focus on information security communication where both the sending and the receiving parties are humans. Technical communication issues is not a part of the scope. Factors that influence the efficiency of human communication is studied by several fields of research outside the discipline information security. The study within this thesis seek to apply information from other fields of research based on a general and pragmatic approach. To make the scope manageable it does not consider every possible aspects and details related to human communication on information security, but provides a framework for further studies of the topic.

1.7 Claimed contributions

The work in this thesis builds primarily on existing information from other areas of research and practises, as referenced throughout the report.

The claimed contribution of this thesis is an enhanced focus on how optimised inter-human communication can be used as a tool to improve information security. The thesis work has resulted in a report that contains:

1. Use case analysis for increased insight into central properties of information security communication.
2. An analysis of different optimisation techniques collected from other areas of research and practises
3. The development of a “Mental model for communication optimisation” (Metacom). Metacom is proposed as a model that could be used to analyse optimisation measures to improve the efficiency of information security communication. It is also suggested as a way to integrate different optimisation techniques collected from other areas of research and practises.

1.8 Thesis outline

Chapter	Content
1	Thesis introduction with problem description and research questions.
2	Description of the research methods.
3	Related work section with different communication models and theories.
4	Analysis of communication models and theories to identify factors for communication optimisation. Construction of a mental model for communication optimisation (Metacom).
5	Description of the importance of communication in the information security discipline.
6	Description of communication use cases in information security with an analysis of their properties. Identification of target groups from the use cases with analysis of their properties. Analysis of how different target groups requires special optimisation considerations with the use of Metacom.
7	Summary of lessons learned when it comes to leverage efficiency with optimised information security communication.
8	Further work.
9	Thesis conclusion.

Table 1: Outline for the thesis.

2 Choice of methods

This section explains the chosen methods and its content. It also explains how they contribute to the research questions. In research there is not always possible or useful to count, measure or weigh the objects under investigation. This is assumed true when it comes to the research question in this project. Therefore, the methods that will be used are qualitative. As Leedy and Ormrod state: “In a qualitative study, the specific methods that you use will ultimately be constrained only by the limits of your imagination.” [2, p. 135] In this research there is applied a creative approach that complies with scientific methods. The following subsections will cover the methods that are used.

2.1 Overview

Almost every aspect of human activities involves communication. This project has focus on communication issues that are relevant for information security. That does not imply that the same issues are irrelevant in other situation. It only confirms some limitation for this research.

Just to consider all the communication that are relevant within the area of information security is a broad topic. Mere technical communication is not within the scope. It is also considered adequate to narrow down the scope further to get a direction for the investigation. The research will cover human communication used in some information security contexts. There is assumed that a sample of communication situations to a small set of unequal target groups is suitable. A small but varied set of communication use cases will allow a more in depth analysis while the variation is assumed to make the findings relevant in a wider context.

The following methods are used to set the focus:

- There is made a description of a set of use cases for information security communication, which includes a definition of the purpose with this communication. This includes information about who is communicating to whom, how it is done and what the information security professional want to achieve. The most important aspect is to reflect importance and variety.
- There is made a description of the target groups for the different use cases, which show properties of the audience (the receivers of the communication). The most important aspect is to reflect importance and variety.
- Then a small set of unequal target groups is selected, suitable to illustrate why communication need to be adapted accordingly. They will be used as focus for the further inquiry.
- The further inquiry uses the communication with the selected target groups as an example, to illustrate how communication challenges can be addressed. This is done by evaluating certain factors that affect this communication and describe in what way they can be optimised towards the target groups. Stated communication success

criteria are used as a reference to determine if the adjustment of the factors influence the communication in a positive or negative way.

The main methods are:

- Literature review
- Creativity
- Analysis and logical reasoning

2.2 Literature review

To obtain useful literature for the study several sources of information have been investigated. Main search effort have been done in ACM Digital Library, IEEE Xplore Digital Library and Springer Link. The following keywords have been used to search these databases: information security communication, information security taxonomy, human communication, human communication rhetoric, human communication motivation, human communication psychology, human communication semiotic, human communication persuasion.

There seem to be little research literature available from these sources that discuss quality aspects of human communication on information security. Search results from the databases did mostly cover technical aspects of communication and information security. This indicates that the main research effort in information security focus on technical aspects. Still some articles provided information relevant for this study. Springer Link provided the best sources since they had a wider perspective than ACM and IEEE Xplore Digital Library.

To get a better foundation for the study of optimised information security communication other sources where examined. This included textbooks and information from internet search. There exist much literature on communication theory, social psychology, psychology, rhetoric, linguistics and semiotics, which was useful in the study of communication optimisation. Communication theory provided basic definition on communication and its purpose. Within this field, many models described important aspects of communication. Different models focused on different aspects and complemented each other. Therefore, it was useful to study several models in order to identify the most important factors that influence the quality of the communication in general. Since the focus was on communication between or towards humans there was be useful with some insights from psychology and social psychology. Communication is conducted in order to achieve some purposes. Theories from psychology and social psychology could therefore provide knowledge about the nature of human behaviour and persuasion. In addition, other relevant secondary sources were also used to reveal other factors that affects the communication. The insight from the literature was used to select the factors assumed important for communication optimisation.

Scientific papers on information security was used to identify typical communication partners for a security professional and the purposes for their communication. This provided a basis for the creation of relevant use cases and target groups.

The literature review was relevant for the research question and all the sub questions in the master thesis.

2.3 Creativity

Even if we were not able to find many studies on communication on information security, there are performed a lot on research on communication in general and related aspects as rhetoric, linguistics and semiotics. There were also a vast material on psychology and social psychology. With such a broad range of data sources, there was a challenge to analyse the impact on communication and present the findings. Creativity was important to make the content of the thesis easy understandable, in a way that supports the goal to improve the communication on information security. It was also necessary to utilise creativity to find different data sources that helped to elicit the most important factors that influences the communication.

2.4 Case studies

By using various methods to analyse a problem it can reveal some different perspectives. Therefore, use case studies of communication scenarios were used to provide further insight. The study of use cases provided practical examples of how different factors could influence communication on information security.

2.5 Analysis and logical reasoning

The data material that was gathered through the research was analysed in order to answer the research question. It was considered in relation to the information security communications that were studied. This implied an assessment of relevance. Only factors that were relevant for the cases were examined further. The communication success criteria were identified based on literature study and experience. The impact of the relevant factors were evaluated further against these success criteria. Analysis of how factors could be optimised to support the communication success criteria, were made based on the knowledge from the data sources and logical reasoning.

An iterative approach was used throughout the work. This means that insights that appeared through the analysis where used to improve previous work. As an example was the initial draft of Metacom improved based on analysis and use cases that appear later in the report.

2.6 Verification

This research suggest Metacom as model to optimise information security communication. The analysis of information security use cases in section 6.2 verifies that the model could support an optimisation effort towards different target groups. The examples in appendix 1 verifies that Metacom also could be used to integrate optimisation techniques from different sources.

A formal technique for measurement of communication efficiency is beyond the scope of this thesis and is suggested for further research.

3 Related work

“The single biggest problem in communication is the illusion that it has taken place.”

- George Bernard Shaw

There are previously done many studies on inter-human communication. Communication is a wide topic and influences every aspect of human lives every day. The focus within this research is to study how to use communication as a tool to improve information security. There seem to be little research directly connected to this problem area, while communication in general is thoroughly examined throughout human history. An important challenge is therefore to elicit useful knowledge from former research and apply it within the area of information security. Since there is, a vast of material on communication there will be necessary to filter out information that will be useful to achieve the goal.

3.1 Defining communication

To clarify the goal is important in order to get the right focus for the study. Since communication is a central term its meaning are of concern. To define the word communication scientifically is not an easy task. An elaboration of this is given by Stephen W Littlejohn and Karen A Foss in [3, pp. 4-5] which is a major work on theories of human communication. Theodore Clevenger referred to in [3] claims that the problem stems from the fact that the verb “to communicate” is a well-established and overworked term of the English language. Therefore, the term is not easy to capture for scientific work. Thus, there exists many different attempts to define communication. Frank Dance cited in [3] has identified three “critical conceptual differentiation” in these definitions:

- The level of observation (or abstractness).

The definition can be broad or narrow (restrictive). For instance to define communication as:

1. *“the process that links discontinuous parts of the living world to one another”*
Jürgen Ruesch cited in [3]. Example of a general definition of communication.
2. *“the means of sending military messages, orders, etc., as by telephone, telegraph, radio, couriers,”*

A restrictive definition from American College Dictionary cited in [3].

- Intentionality.

Some definitions includes only situation where there exists an intention with the communication, while others do not require this.

1. *“Those situations in which a source transmits a message to a receiver with conscious intent to affect the latter’s behaviors.”*
Gerald R. Miller cited in [3] includes intention in this definition.
2. *“Human communication has occurred when a human being responds to a*

symbol.”

Gary Cronkhit cited in [3] has here a definition which do not require intention.

- Normative judgement.

This distinction shows that some definitions include a statement of success, effectiveness, or accuracy while others do not consider any such judgement.

1. *“Communication is the verbal interchange of a thought or idea.”*

This definition by John B. Hobden cited in [3] presumes that the thought or idea is successful interchanged.

2. *Communication is “the transmission of information.”*

In this definition by Bernard Berelson and Gary Steiner cited in [3] the information is just transmitted. There is no requirement that the information is received or understood.

The examples above show that there is no unified definition of communication. There exist different definitions in different theories. Littlejohn and Foss state that: “Different definitions serve different functions and enable theorists to do different things” [3, p. 5]. Therefore, a pragmatic approach is chosen here. The definition should help to answer the question under investigation.

The purpose of this study is to enable security professionals to use communication as a tool to increase information security. A definition given by Carl I. Hovland in [4] is regarded to be useful to support this intent. Hovland define communication “as the process by which an individual (the communicator) transmits stimuli (usually verbal symbols) to modify the behaviour of other individuals (communicatees).” As a consequence Hovland state that there is necessary to analyse four factors [4]:

1. “the communicator who transmits the communication;”
2. “the stimuli transmitted by the communicator;”
3. “the individuals who respond to the communication;”
4. “the response made to the communication by the communicatee.”

Hovland’s definition above focuses on intentionality, which is important when a security professional seeks to use his communication skills to improve information security. Even so, he needs also to be aware of the effect of non-intentional factors of communication. Thomas R. Nilsen in [5] gives useful examples which illustrates the diversity of communication. He divides definitions of communication into two broad categories. The first is stimulus-response situations where the communicator deliberately transmits stimuli to evoke response. The second includes stimulus-response situations, the stimuli may be transmitted without any intention of evoking any response.

The word communication stems from the Latin word “communis” i.e. “common” according to Online etymology dictionary [6].

When we talk about communication within the context of this thesis, there exist a purpose to make something common between yourself as the security professional and our

communication partner(s). This could be the sharing of ideas, information, attitude and behaviour. The success or efficiency of the communication will then be determined by to which extent we are able to influence or make common, the message to our communication partners.

Awareness of different perspectives on communication will give a good point of departure for identifying factors that influence it.

3.2 The purpose of communication

Human communication serves different purposes. When we study communication optimisation, it is necessary to have a clear picture of what we will try to achieve. According to Joan Murphy [7], Janice Light suggested in [8] that there were 4 main purposes for human communication:

Cited from [7], Light described these purposes as:

- “1. Expression of needs and want – to regulate the behaviour of another person to get something*
- 2. Information transfer – to convey information from person A to person B*
- 3. Social closeness – to establish and maintain relationships with others*
- 4. Social etiquette – to conform to the social conventions of politeness”*

Murphy argues that modern communication aids often focus on 1 and 2 and not so much on 3 and 4. Consequently, a person with communication difficulty may strive to establish and maintain relationships. This argument refers to an text by John Locke in [9] who wrote that (cited from [7]):

“‘small talk’ is crucial for the construction and enjoyment of relationships with others and that by revealing thoughts we elicit reactions from others. This is what we regard as social closeness or engagement. ‘Small talk’ or ‘social closeness’ may sound irrelevant but it is one of the most important purposes of human communication.”

3.3 Factors that influence communication

To optimise communication in order to improve information security there is necessary to be aware of factors that influence the communication process. By identifying and evaluating these factors, there should be possible to design recommendations for efficient communication.

Study of different communication theories and models are performed to identify factors. There exist a lot of different theories on communication that seems to be operating in different domains according to Robert T. Craig [10]. He claims that books and articles on communication theory seldom mention other work outside their own domain. Therefore, theorists neither agree nor disagree about much of anything. Craig concludes, “there is no consensus on communication theory as a field”.

Despite this, different perspectives on communication will be useful to obtain information about factors that influence our communication. Theories and models are abstractions.

They are simplified concepts of the real world and choose to focus on certain aspects of it. Because of their perspective, they also leave something out and none of them captures the whole truth about the universe. Even so, they are useful to help us understand, explain, predict and control certain phenomena [3].

3.4 Communication models

3.4.1.1 Aristotle's communication model

Even if Aristotle lived 300 years Before the Christian Era (BCE) his theories on communication is still relevant today. He defined Rhetoric as : “the faculty of observing in any given case the available means of persuasion”[11, loc. 114].

Aristotle divided his communication model into 3 parts: the speaker, the subject and the person addressed.

For of the three elements in speech-making – speaker, subject, and person addressed – it is the last one, the hearer, that determines the speech's end and object.[11, loc. 226-227]

As we can see the audience, (the person addressed) is considered the most important part of the communication. The person addressed is the key to whether or not communication has occurred.

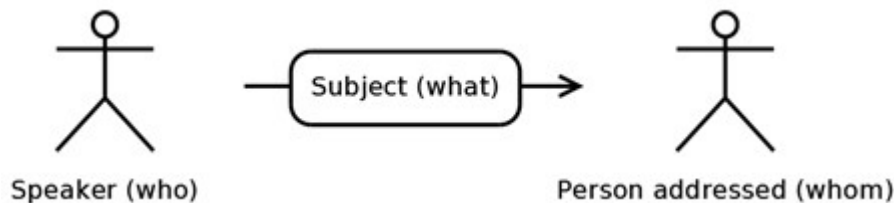

Figure 01: Illustration of Aristotle's communication model by Sveen

3.4.2 Lasswell's communication model

Harold Lasswell had focus on the structure and function of communication in the society. He described the act of communication in [12] like this:

Who Says What In Which Channel To Whom With What Effect?

Compared to Aristotle's model we can see that many of the elements in the communication model are the same. Who Says (Speaker), What (Subject) and To Whom (Person addressed). In addition, Lasswell added Channels and he was concerned about what effects that were the outcome of the process. The speaker (Who) must have caused an effect before we can say that communication has occurred according to Lasswell. [12]

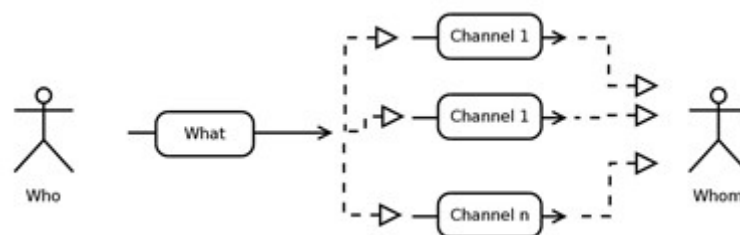

Figure 02: Illustration of Lasswell's communication model by Sveen

3.4.3 Shannon and Weaver's communication model

Mathematician Claude E. Shannon published "A Mathematical Theory of Communication" in 1948 where he illustrated a schematic diagram of a general communication system [13]. The purpose was originally to devise a technical communication system with optimal efficiency. It was later published in a book [14] under a slightly different title together with Warren Weaver after realising that the work had general value outside the intended purpose.

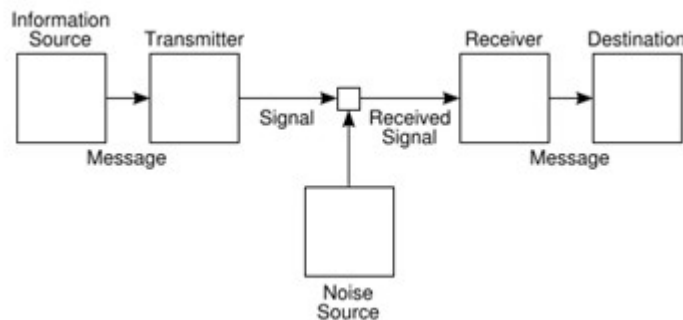

Figure 03: Shannon and Weaver's communication model from [13]

In principle, this model also contains much of the same elements as Aristotle's model: Information Source (Speaker), Message (Subject) and Destination (Person Addressed). The Transmitter and Receiver are parts of the communication channel in this context. A Noise Source is also included in this model, which disturbs the communication. Originally, from Shannon this was meant to illustrate factors that may reduce the quality of the signal while it is transmitted through the technical transmission channel from the transmitter to the receiver. E.g., a message transmitted by radio may be destroyed or degenerated by an external radio transmitter, which uses the same frequency.

On the other hand as described by Weaver in [15], it is possible to think about the model in a different way. If we just consider the non-technical aspect of communication, the noise element can signify the different non-technical factors that disturb the communication. This could be semantic noise from language barriers between the sender and receiver, difference in interpretation of word, difference in knowledge about the subject etc.

Weaver divides the communication problems into three levels[15]:

- Level A. The technical problem: How accurately can the symbols of communication be transmitted?
- Level B. The semantic problem: how precisely do the transmitted symbols convey the desired meaning?
- Level C. The effectiveness problem: How effectively does the received meaning affect conduct in the desired way?

The focus of the technical problem is about the transmission of sets of symbols from the sender to the receiver. The possible set symbols will vary according to transmission medium but can e.g. be written characters, voice, image etc. If the sender transmits "1010" the same bit pattern "1010" is expected to be received by the receiver. The technical

problem investigate how this can be done most effectively with necessary detection and recovery mechanisms.

The semantic problem deals with difference in perception between the sender and the receiver. Even when the symbols are perfectly transmitted (by the technical level) from the sender to the receiver, the message might not be interpreted as desired. Misunderstanding can occur several ways. E.g., different words can have different meaning for the sender and the receiver. The message: “I have got a virus” might be interpreted differently by a security expert and a doctor. The semantic problem occur often also in relative simple speech communication situations.

The effectiveness problem deals with the outcome of the communication. With a broad definition of conduct it, can be stated that the sender always want his communication to affect the conduct of the receiver. If it do not affect conduct, it has probably no effect at all. The effectiveness problem show that the communication may fail even when the message is correctly received and interpreted. E.g. if the sender, ask the receiver “please keep this secret to yourself”, the receiver may consciously choose to ignore his appeal.

With Weavers three communication problem levels, it can be observed that level A is concerned with technical issues while level B and C is related to human aspects.

3.4.4 Schramm’s communication model

Wilbur Schramm is considered as one of the founding fathers of the Mass Communication field. Originally inspired by Shannon’s model he produced his own communication model in [16] and provided later several additional models.

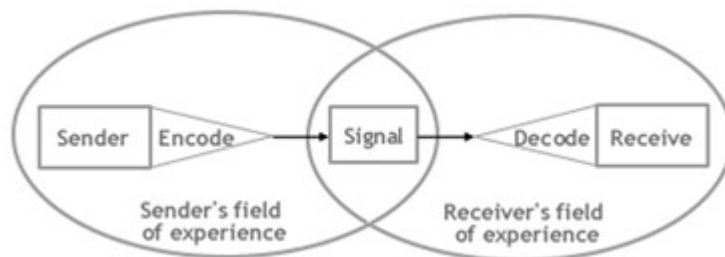

Figure 04: Schramm’s communication model 2 (1954) from [17]

In this model, we still have the three elements from Aristotle’s model: Sender (Speaker), Signal (Subject) and Receiver (Person Addressed). The message (Subject) is Encoded by the Sender and is transmitted in form of a Signal. The Receiver Decodes the Signal to get the message.

Schramm extended the understanding of the communication process by including sociological aspects. He pointed out that the sender and the receiver must have something in common, if the communication shall succeed. As it appears in this model, the common area (field of experience) is where communication is possible. If this common area is small or do not exist at all, communication would be difficult or impossible. Then the receiver will not be able to decode the message and understand it in the way it was intended by the sender. [17]

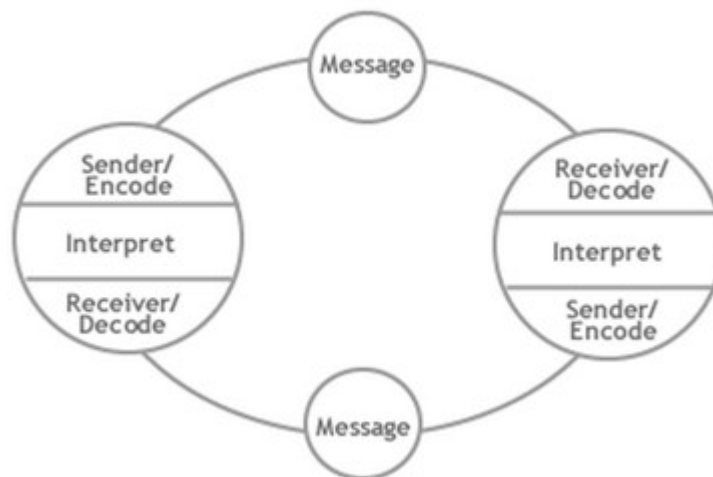

Figure 05: Schramm's communication model 3 (1954) from [17]

In Schramm's third model, he introduces a feedback loop. Various forms of noise may distort the message on its way to the receiver. The feedback from the receiver to the sender makes it possible to determine if the message is understood correctly and make corrections when necessary. It can be observed that in this model the communication process takes a circular form. Both parties act as both sender and receiver. This model emphasizes the importance of feedback to ensure that the receiver understands the message as intended by the sender. [17]

3.4.5 Riley & Riley's communication model

John W. and Matilda White Riley developed another model to describe sociological implications in communication. The Rileys points out the important roles of primary groups and reference groups in communication. [18]

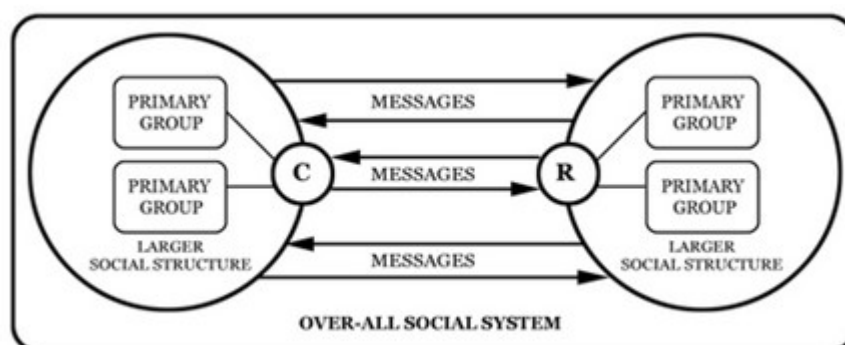

Figure 06: The Rileys's communication from [19]

This model illustrates how the communicator © and receiver ® both are parts of social structures. The communicator is a part of some primary groups and a larger social structure. The expectation, social characteristics and backgrounds of the primary social

groups will be reflected in the message sent. Likewise, the receiver will receive the message as a member of his primary sociological groups. [19]

The primary groups are distinguished by the level of intimacy according to Rileys. A group from which a person may define his attitudes, values and behaviour is called a reference group. Members in a primary group will influence the attitude and behaviour of each other but also in a degree by the larger social structure. [19]

3.4.6 The Johari Window Model

The American psychologists Joseph Luft and Harry Ingham developed the Johari Window Model in 1955 [20]. The name of this model came from joining their first names. In order to improve communication this model focuses on self-awareness and personal development of individuals in a group environment. [21]

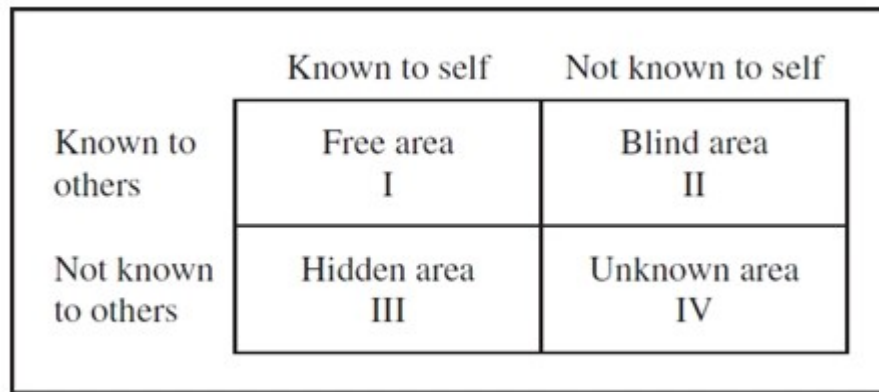

Figure 07: The Johari Window from [21]

The four quadrants illustrate different aspects of interpersonal communication and are described by Luft in [20]. In quadrant 1 the individual's attitude, behaviour, emotions, skills, feelings views and motivations are known to self and others. This is called the free area, and represents the area of open communication. The quadrant 2, known as the blind area represent factors that others can see in ourselves, but we are unaware. The quadrant 3 called the hidden area is factors, which we are aware of but choose to keep hidden from others. The unknown area in quadrant 4 represents factors like behaviour and motives that neither individuals nor others are aware. The existence of such factors is assumed. At some point a factor from this area may be know and it is then revealed that it affected the relationship (and thus the communication) all along. [20]

The outside frame of the window is considered to be fixed and communication improves when we are able to expand the free area. This is done by diminishing the blind, hidden and/or unknown area. In order to decrease the blind area it is useful to seek feedback from others. Learning about their perception of you increase your knowledge (expand the free area) and decrease the blind area. You are no longer blind to factors you are aware. By giving feedback to others, you will reveal more of yourself to them. You expose and share parts of your (until now) hidden area. Then you expand the free area by diminishing the

hidden area. The unknown area will decrease consequently when the blind and/or hidden area diminishes. There will remain an unknown area to explore. This is about self-discovery and can be pursued in different ways: e.g. by doing things that you have not done before, by paying attention to what stimulates you and by exploring your dreams and by bring into use untapped skills, talents and resources that you possess. [20]

Creating more commonality by increasing the free area leads to communication that is more efficient. [20]

3.4.7 The AIDA Model

The AIDA model has its origin in marketing communication. It was coined by Elias. St. Elmo Lewis in the late 1800s. This model is still relevant today for instance, when advertisement copywriters try to convince the customers to buy their product. It contains of four steps, which are attention factor, interest element, desire element and action element. Thus, the acronym AIDA stands for Attention, Interest, Desire and Action. [22]



Figure 08: Visualisation of the AIDA model from [23]

The model describes how people are motivated to buy a product influenced by external stimuli from sales personnel. In this sale context, the steps could be like this [23]:

- **Attention:** The advertisement grabs the attention of the potential customer by using different measure like: image, colour, typography, size, sound, motion, celebrity etc.
- **Interest:** Once the attention is grabbed, it is necessary to invoke interest in the mind of the customer, so he will read/ hear or see more about the product being advertised.
- **Desire:** The desire element is to convince the customer of the necessity of buying the product by describing features and benefits.
- **Action:** This part is there to make the customer take immediate action to obtain the product. E.g. by giving ordering information and discount of limited duration.

Marketing is about mass communication and influencing behaviour of people. The aim is not only to sell products, it could also be to inform, persuade or inform people on different issues. [22] The model is usually visualised as a funnel to illustrate the point that you lose some people for each step of the process. [23]

3.5 Propaganda

Propaganda is about communication of information to the masses, in order to make influence. An insight into this topic will therefore reveal important aspects on how to obtain effective communication. Propaganda used during wartime employs methods that are irrelevant or unacceptable for information security communication. Even so, a study of propaganda will yield important information about factors that affects human communication. It is important to consider how to apply this information, since it certainly will have ethical aspects.

Pope Gregory XV coined the word propaganda in 1622 according to Edward Bernays in [24]. As a reaction to the global spread of Protestantism, he proposed an addition to the Roman Curia. The Office for the Propagation of Faith should deal with every concern for the spread of the faith throughout the world.

Bernays state that the word was not use much in English prior to World War I. Propaganda can be used to make a sinister impression, but the word did not automatically had that meaning. Political use of the term during wartime change the public perception of the term. The governments used it to influence the public opinion in their countries to ensure support from the masses. During the war they termed the announcements from the enemy propaganda, while their own mass communication where described as information. This also implied that any information from the enemy was false and untrue (propaganda), while all the information from the own government was true. [24]

George Creel the director of the U.S. Office of War Information stated it like this cited in [24, loc. 84]: “Our effort was educational and informative throughout, for we had such confidence in our case as to feel that no other argument was needed than the simple, straightforward presentation of facts.”

After World War I people recognised that this so-called information from their own government, sometimes were misleading. In this period Edward Bernays tried to reclaim the more neutral definition of propaganda in his book by the same name [24]. He argued that propaganda could be either good or bad dependent of its use. Then people can judge the use of propaganda based on the merit of the cause urged, and whether the published information is correct. Bernays refer to the four definitions of the word propaganda in Funk and Wagnall’s dictionary cited in [24, loc. 472]:

“1. A society of cardinals, the overseers of foreign missions; also the College of Propaganda at Rome founded by Pope Urban VIII in 1627 for education of missionary priests; Sacred College de Propaganda Fide.”

“2. Hence, any institution or scheme for propagating a doctrine or system.”

“3. Effort directed systematically toward the gaining of public support for an opinion or a course of action.”

“4. The principles advanced by a propaganda.”

This definition do not connect the word propaganda with a vicious intention. According to Bernays “Propaganda becomes vicious and reprehensive only when its authors consciously and deliberately disseminate what they know to be lies, or when they aim at effects which they know to be prejudicial to the common good.” [24, loc. 490] Bernays effort to save the reputation of the word propaganda did not succeed, but he was very successful in applying

its methods in public relation work.

Use of propaganda during World War II solidified the negative association with the word. A modern definition of the word from Oxford Dictionary of English illustrate this. It describes propaganda as: “information, especially of a biased or misleading nature, used to promote a political cause or point of view” [25].

The further study of propaganda below make use of Bernays book on Propaganda [24] and an analysis done by Leonard W. Doob of propaganda principles employed by the German Propaganda Minister Joseph Goebbels in the Third Reich [26].

3.5.1 A general introduction to propaganda

The use of propaganda in this section seeks to explain what it is and how it works. The purpose here is not to judge it as good or bad, just to understand and explain how it works. Bernays reflection on propaganda illustrate basic thoughts on the subject. Even if it was first published in 1928, the book still relevant to understand the social science and psychological manipulation that lies beneath techniques of public communication. Bernays were among others influenced by the French social psychologist Gustave Le Bon, Wilfred Trotter a British surgeon and social psychologist, and the American writer, reporter and political commentator Walter Lippmann [24].

Governments developed propaganda techniques during the World War I. They used visual, graphic and auditory measures to get support for ideas. In addition, they recognised the importance of authorities within different group structures. This could be religious, commercial, social, local groups in the society. By securing support from key men within these groups, they automatically gained support from their members. Stories about atrocities and terror of the enemy made emotional mass reactions. [24]

Formerly the rulers where the leaders and did what they wanted. It might still be the case in totalitarian states today, but it is hard to control the flow of information with the current technology. The “Arab Spring of 2010 demonstrated this. In democratic states, the governments need the support from the masses to accomplish anything. They cannot do what they want without this support.

Bernays saw propaganda as an important method to control the masses in a democratic society to ensure order and avoid chaos. “The conscious and intelligent manipulation of the organized habits and opinions of the masses is an important element in democratic society. Those who manipulate this unseen mechanism of society constitute an invisible government which is the true ruling power of our country.”[24, loc. 343]

Based on this view, most people get their mind moulded, their taste formed and ideas suggested by men they have never heard of. Bernays put forward that a small number of persons dominates us, they “who understand the mental processes and social patterns of the masses” [24, loc. 351]. This small minority denoted the invisible government use propaganda as its executive force.

In a democracy, every citizen can make his own mind about public issues and his private affairs. If everybody should study all relevant information to establish his opinion in any

questions, it had been an impracticable task. Therefore, we more or less consciously let authorities narrow down our choices to a practical range. Even if a reduction of choices is necessary, it makes us easy to manipulate. [24]

Bernays claim that propaganda is a necessity to achieve anything of social importance in the society. In the democratic ideal, the common person should learn how to read and write to so he could develop his own mind. Merely a few take advantage of the possibility to control their own mind. The masses are an easy target for rumours, advertisement slogans, editorials, news or scientific data and get most of their ideas in this way. Therefore, “the mechanism by which ideas are disseminated on a large scale is propaganda, in the broad sense of an organized effort to spread a particular belief or doctrine.” [24, loc. 461]

Anyone who scrutinise news articles at any day will be able to notice the traces of propaganda. Few article just report just facts from and incident, they often try to influence people towards an opinion. There is not necessarily a mean intention behind this, but they are still conscious attempts to direct the public opinion. [24]

Bernays calls this the new propaganda and defines it like this: “Modern propaganda is a consistent, enduring effort to create or shape events to influence the relations of the public to an enterprise, idea or group.” [24, loc. 511]. Propagandists use propaganda consciously to create pictures and circumstances in the mind of the masses. They perform this task universal and continuous to regiment these minds. In this way the control the peoples mind in just as much, as an army control its soldiers. Since they are vast in numbers and tenacious when regimented, they create a huge group pressure. Leaders and supposedly powerful beings within society cannot withstand this force and become merely “driftwood in the surf” [24, loc. 522].

Modern propaganda do not only work on the individual or the mass mind alone. It analyses the organisation of the society with its group structures and loyalties. The individual is not only a part of a society, but also connected to a set of groups. Touching the nerve of a sensitive spot will generate a response from specific members of the society. [24]

The modern propagandist goes under title like “public relation counsels” and “information advisor”. They specialises in interpreting enterprises and ideas to the public, but also interpret the public to the promulgators of new enterprises and ideas. When an enterprise understands the public, it will be more able to interpret itself to them. [24]

A successful enterprise know it needs public opinion as a partner to achieve its goals and stay successful. They therefore make an effort to attain the interest, acceptance and approval of the public. Thus, it is important to convince them that the enterprise operate honest and fair, and acknowledge their demands. The public may not appreciate the value of an enterprise if they do not understand or know about it. The enterprise can establish a system with continuous, thorough, open and honest information to create enlighten their minds. Good information may also counter false information from unverified sources. [24]

To influence group behaviour it is important to understand the psychology behind it. Studies has shown that the mental processes of a group is different from those of the individual. Knowledge on individual psychology is not applicable to explain impulses and emotions that stimulate group behaviour. [24]

Bernays admits that propaganda is not a precise science since it is dealing with human beings. This is also the case in other scientific fields and do not rule out the possibility to build knowledge on the subject. He argues that observation of the applied principles of propaganda has shown consistency and relative constant results.

His theories state that if you can influence the leaders with or without their conscious cooperation, you will automatically make influence on their group members. He thinks most people have a herd mentality, so their minds operates on patterns from the group influence even when they are alone. Therefore, it is false when they do think they are acting based on their own judgement. An outside influence control their thoughts unconsciously and therefore direct their behaviour. [24]

According to Trotter and Le Bon referred in [24] the group mind do not have thought, but it has impulses, habits and emotions. Its first impulse is usually to follow the trusted leader due to its herd mentality. This principle operates for instance to cause panic on the stock exchange or creating a best-seller. When the leader is not there, the herd must think on its own. "It does so by means of clichés, pat words or images which stands for a whole group of ideas or experiences" [24, loc. 778]. The fear of be stamped with the label "communist" may frighten the public from perform certain actions or make certain statements. The use of carefully considered words might change the opinion of the masses. This illustration shows just one example of this:

"By playing upon an old cliché, or manipulating a new one, the propagandist can sometimes swing a whole mass of group emotions. In Great Britain, during the war, the evacuation hospitals came in for a considerable amount of criticism because of the summary way in which they handled their wounded. It was assumed by the public that a hospital gives prolonged and conscientious attention to its patients. When the name was changed to evacuation posts, the critical reaction vanished. No one expected more than an adequate emergency treatment from an institution so named. The cliché hospital was indelibly associated in the public mind with a certain picture. To persuade the public to discriminate between one type of hospital and another, to dissociate the cliché from the picture it evoked, would have been an impossible task. Instead, a new cliché automatically conditioned the public emotion toward these hospitals" [24, loc. 778].

Further, Bernays claim that men are seldom aware of the reason that motivates their action. They will often unconsciously fool themselves by making up motives that are not the real reason. The psychology based on Freud thinks this is substitutes for supressed desires. "A thing may be desired not for its intrinsic worth or usefulness, but because he has unconsciously come to see in it a symbol of something else, the desire for which he is ashamed to admit to himself" [24, loc. 789].

The general principle that men act upon motives that they unaware of is important. This is believed to be true both individual and mass psychology. They who seeks to influence men must therefore find the true motivation, and not accept the reason given direct from the actors. Human desires are the true motivation, but a person may be unaware of his own desires. [24]

Examples below show how of different propaganda techniques influence which products a customer chooses to buy. The same principle is applied to achieve support for an idea.

Group custom influences what people choose to buy. It may not be that the customer

himself prefer one thing to the other, but he will often end up buying what other people in his group normally prefer. To influence this pattern it is necessary to make an effort that creates circumstances that change the group custom. By working indirectly through circumstances the change in behaviour will come to the customer as his own idea. [24]

Another method to influence customer attitude towards a product, is to use the associative process. By creating circumstances to link a product with a good purpose, a happy event, a respected celebrity and so on, the status of the product increase. [24]

Already addressed is the positive gain that stems from the support of group leaders. It is important to understand that these leaders will only lend their authority to a propaganda campaign if it somehow is in their own interest. Therefore, it is important to analyse interests of groups or individuals, which coincide with the propaganda campaign. [24]

If a business shall be successful over a longer period, it must be aware of its relation to the public. This is not limited to the product it sells, but all things that the firm stand for in the public mind. Therefore, business must be conscious to the public's conscious, to achieve a healthy relationship. The relationship should be friendly and mutual beneficial. It is important to realise that conflicts and suspicion are damaging for both parties. To gain goodwill from the public a business must express its existence in a way that they understand and accept. The business should dramatise its personality and explain its objective to the community [24].

These ideas of propaganda provide by Bernays may seem to patronise human beings. The idea that they in general are unconscious and easy to manipulate may seem provocative. Anyhow, it is easy to recognise that many of the described techniques are prevalent in our society today.

3.5.2 The use of propaganda in the Third Reich

The German Propaganda Minister Joseph Goebbels in the Third Reich was for many years regarded as a master of his trade. Leonard W. Doob has made an analysis of Goebbels activity and enumerate 19 different principles of propaganda in [26]. The principles describe how to perform propaganda as a tool for effective mass communication. Of course is the propaganda in this war scenario very different from our purpose to communicate information security. Therefore, some of these principles are not so relevant. Others are unacceptable for ethical reasons. Nevertheless, a study of these principles provide some understanding in psychology and persuasion. Each principle numbered below contain a description. Description of less relevant principles are kept short.

1. "Propagandists must have access to intelligence concerning events and public opinion." [26, p. 422]

This principle underline the importance that the communication message (the propaganda) is adapted to the situation. That is to gather information about the current situation and to know about the attitude among the intendent audience. The propagandists also made an effort to control the information flow by hiding the real information. This means to hold back the true reports about the situation, from the people.

Information about the audience (the Germans) where collected in several way. This intelligence was not gathered or analysed systematically. Goebbels was sceptical about

statistical investigation i.e. done by the Gallup Institute, since such investigation in his opinion, always are done with a specific purpose in mind. He had greater trust in his own intuition and his mother to know the sentiments of the people more than scientific inquiries. [26]

2. “Propaganda must be planned and executed by only one authority.” [26, p. 423]

This principle claims that propaganda will be most effective when it is under control of a single authority. This authority then must perform three functions:

- It must issue all the propaganda directives.
- It must explain propaganda directives to important officials and maintain their morale.
- It must oversee other agencies’ activities which have propaganda consequences

Even a totalitarian regime like Nazi Germany was not able to implement these principles fully, due to rivalries and animosities among different people and institutions within the state. [26]

3. “The propaganda consequences of an action must be considered in planning that action.” [26, p. 424]

This principle argue that the state should consider propaganda aspects when it plan how to perform its actions. As an example, the Propaganda Ministry should be charge of a trail in France rather than the German Ministry of Justice, so that «everything will be seized and executed correctly from a psychological viewpoint» [26, p. 424]. Another example was to conduct the air warfare against England on psychological rather than military principles.

The rationale behind this stand was that the propaganda would be more effective when they could plan an event, rather than rationalise one that has occurred. [26]

4. “Propaganda must affect the enemy’s policy and action.” [26, p. 424]

This principle emphasizes that propaganda shall change the audience behaviour. In addition to damaging enemy morale, it should affect the policy and actions in four different ways:

- “By suppressing propagandistically desirable material which can provide the enemy with useful intelligence.” [26, p. 425]

There may be cases where the use of propaganda may lead to more loss than gain. For instance revealing weakness in the enemies weapons, could strengthen Germans morale while at the same time provide important intelligence for the opponent. [26]

- “By openly disseminating propaganda whose content or tone causes the enemy to draw the desired conclusions.” [26, p. 425]
- “By goading the enemy into revealing vital information about himself.” [26, p. 425]
- “By making no reference to a desired enemy activity when any reference would discredit that activity.” [26, p. 425]

5. Declassified, operational information must be available to implement a propaganda campaign.” [26, p. 426]

This principle is about implementing some real or true information in the propaganda. The

propaganda material could not be completely constructed, it needed some facts not matter how slight. By using real events mixed with the propaganda, it would be more effective. [26]

6. “To be perceived, propaganda must evoke the interest of an audience and must be transmitted through an attention-getting communications medium.” [26, p. 426]

This principle describes different ways to influence the intended audience. During the war, the propagandists used media like radio transmissions, movies, newsreels, theatres, newspapers and leaflets. They choose the media that they thought had best possibility to affect the audience the way they wanted. It was necessary to use a media used by the target group. E.g., the ban on radio receivers in occupied countries made radio transmissions less effective. Still it was useful to influence audience in enemy territories. Adaption of the timing of broadcast transmissions to local time in the current country, made it more likely to attract listeners. By mixing propaganda with other kind of content like entertainment content and strait news, they were better able to attract and hold the audience. Goebbels assessed visual images to yield greater credibility than spoken or written words. This was the case even with manipulated images.[26]

7. “Credibility alone must determine whether propaganda output should be true or false.” [26, p. 428]

Goebbels had no moral considerations about the truth in the propaganda. Credibility was the only consideration assessed when making a propaganda message. Therefore, he used the truth as much as possible to prevent exposure of falsehood by facts or by the enemy. He also assessed the likelihood of success with certain audiences. As an example he thought Germans were more difficult to deceive than during World War One since they now could “read between the lines”[26, p. 428].

8. “The purpose, content, and effectiveness of enemy propaganda; the strength and effects of an expose; and the nature of current propaganda campaigns determine whether enemy propaganda should be ignored or refuted.” [26, p. 429]

This principle is about analysing propaganda from the enemy before conducting any response. If the purpose seemed to elicit a reply, they gave no reply. Reply exposed enemy propaganda when it contained blatant falsehood, to reduce its credibility. [26]

9. “Credibility, intelligence, and the possible effects of communicating determine whether propaganda materials should be censored.” [26, p. 431]

This principle show that only the presumed effect of the propaganda and not moral, determined use of censorship. Goebbels stated it in this way: “News policy is a weapon of war; its purpose is to wage war and not to give out information” [26, P. 431].

10. “Material from enemy propaganda may be utilized in operations when it helps diminish that enemy’s prestige or lends support to the propagandist’s own objective.” [26, p. 432]

This principle demonstrated how to use enemy propaganda to support own objectives. By analysing the content, it was possible to use the word of the enemy. One way is to collect lies in enemy propaganda over a period, and use it to ruin their credibility. Another

example is “strength-through-fear” campaign described in principle 16. [26]

11. “Black rather than white propaganda must be employed when the latter is less credible or produces undesirable effects.” [26, p. 433]

This principle discusses whether to reveal the origin of the propaganda material. “White” propaganda openly state the source; while “black” propaganda conceal the true source. Again, the credibility and effect of the propaganda determine the strategy. Goebbels thus used “black” propaganda when it was undesirable that the audience were aware of that the message came from German authorities. One way to perform “black” propaganda was to plant information as rumours. [26]

12. “Propaganda may be facilitated by leaders with prestige.” [26, p. 434]

This principle displays the importance of authority. Propaganda published by leaders with prestige was more effective in convincing the audience. Therefore, he expected exemplary behaviour on German leaders. Incompetent and greedy Nazi leaders would make it difficult to urge the ordinary Germans to make greater sacrifices and trust their government. [26]

13. “Propaganda must be carefully timed.” [26, p. 434]

This principle elaborates on how correct timing is important for achieving best propaganda effect. The propagandist should be able to “calculating psychological effects in advance” [26, p. 434]. The three different principle below show timing considerations:

“a. The communication must reach the audience ahead of competing propaganda” [26, p. 435]

Goebbels stated the importance of speed like this: “Whoever speaks the first word to the world is always right”. [26, p. 435]

“b. A propaganda campaign must begin at the optimum moment” [26, p. 435]

“c. A propaganda theme must be repeated, but not beyond some point of diminishing effectiveness” [26, p. 435]

The propagandists used repetition as a method to establish a truth through propaganda, much the same way as described in educational science. Further repetitions reinforced the learning. In situation where the public were convinced, or the message became boring or unimpressive they avoided further repetitions. [26]

14. “Propaganda must label events and people with distinctive phrases or slogans.” [26, p. 435]

This principle focus on the words role in propaganda. When people have no personal experience with an event, the use of words could often affect how they react to the event. Therefore, it was important to form phrase and slogans to support the propagandas objective. The phrases and slogans should possess certain characteristics to achieve this effect:

“a. They must evoke desired responses which the audience previously possesses.” [26, p. 436]

By using phrases, that link an event to some knowledge that people possess beforehand, the words can elicit the desired response. Phrases and slogans used this way to explain news events, so the people interpreted it the “right” way. The propaganda then produced

the desired feelings among the people.

“b. They must be capable of being easily learned.” [26, p. 436]

Simplicity was important to facilitate learning. Goebbels stated it like this: “It must make use of painting in black-and-white, since otherwise it cannot be convincing to people.” [26, p. 436]

“c. They must be utilized again and again, but only in appropriate situations.” [26, p. 437]

When the people have learned the verbal symbols, they propaganda should reuse it in every proper situation. This strengthen the slogan and make the propaganda more efficient. On the other hand, they saved certain terms for special occasions. That kept the special power in a word or slogan. The words “Fuehrer” and “Reich” are such examples.

“d. They must be boomerang-proof.” [26, p. 437]

I was important to choose terms that could not hit back. Examples of word they avoided for this reason were “sabotage” and “assassination”. [26]

15. “Propaganda to the home front must prevent the raising of false hopes which can be blasted by future events.” [26, p. 437]

Since some German military victories later could turn into failure, they did not announce them too loudly. The long-term credibility of their propaganda could suffer if they used such event for short-term gain. [26]

16. “Propaganda to the home front must create an optimum anxiety level.” [26, p. 438]

An important task for the German propaganda machinery was to ensure support from the German population. They used anxiety as a tool to manipulate them. At the same time they was aware of the need of balance, since anxiety could be a double-edged sword. If they created too much anxiety, it would lead to panic and demoralisation. Too little anxiety could yield complacency and inactivity. They therefore used these two principles to balance between the two extremes:

“a. Propaganda must reinforce anxiety concerning the consequences of defeat.” [26, p. 438]

To keep up the fighting spirit among the German people, the propagandists reinforced the anxiety by propagating how a potential enemy victory would harm their lives.

“b. Propaganda must diminish anxiety (other than that concerning the consequences of defeat) which is too high and which cannot be reduced by people themselves.” [26, p. 439]

When war events made too strong anxiety levels in the population, the propagandist tried to reduce it. For instance to claim that a certain military defeat did not affect the Germans chances for an ultimate victory. [26]

17. “Propaganda to the home front must diminish the impact of frustration.” [26, p. 439]

This expressed how propaganda should prevent Germans from being frustrated and lose faith in their government. When it was impossible to avoid frustration, they applied the following two principles:

“a. Inevitable frustrations must be anticipated.” [26, p. 439]

To diminish the shock from bad news the German people received some indications beforehand through propaganda.

“b. Inevitable frustrations must be placed in perspective.” [26, p. 439]

Goebbels thought it was important that he provided so called “Kriegsüberblick” for the

German people. There he made a general survey of the war so they kept their focus on the big picture. This effort should maintain the regimes support from the people even when they had to make so many sacrifices. [26]

18. "Propaganda must facilitate the displacement of aggression by specifying the targets for hatred." [26, p. 440]

When aggression occurred, it was important to lead it away from the Nazi regime. One method was to redirect aggression to hate objects like "Bolsheviks" and Jews. They also fomented hate, distrust and suspicion between their enemies or groups within other countries. In this way, they used the aggression to fight each other. [26]

19. "Propaganda cannot immediately affect strong countertendencies; instead it must offer some form of action or diversion, or both." [26, p. 440]

Goebbels made distinction between "Haltung" (attitude and behaviour) and "Stimmung" (feeling, spirit and mood) in his propaganda strategy and objectives. It was a goal to keep both of these components as good as possible. Since "Stimmung" was more volatile it could easily be influence by propaganda or events. For instance improving it by offering entertainment and relaxation. It was vital to maintain "Haltung" for securing support to the regime, so the people did not became ready to surrender. At the end of the war, the Germans experience so many defeats that it seemed impossible to maintain "Stimmung". [26]

Goebbels knew that his propaganda was not always useful. There were identified six different such situations: [26, p. 441]

- "The basic drives of sex and hunger were not appreciably affected by propaganda."
- "Air raids brought problems ranging from discomfort to death which could not be gainsaid."
- "Propaganda could not significantly increase industrial production."
- "The religious impulses of many Germans could not be altered, at least during the war."
- "Overt opposition by individual Germans and by peoples in the occupied countries required forceful action, not clever words."
- "Finally, Germany's unfavourable military situation became an undeniable fact."

3.6 Persuasion

Communication is never neutral; it has a purpose regardless of if the practitioners are aware of it. With awareness of purpose, it is possible to strengthen the effectiveness of communication.

Garth S. Jowett and Victoria O'Donnell provide a model on persuasion in their book Propaganda and Persuasion [27]. They define persuasion as "a complex, continuing, interactive process in which a sender and a receiver are linked by symbols, verbal and nonverbal, through which the persuader attempts to influence the persuadee to adopt a

change in a given attitude or behavior because the persuadee has had perceptions enlarged or changed.” [27, p. 31]

3.6.1 Aristotle’s rhetoric

A central theory of persuasion is described in Aristoteles work with the title “Rhetoric”. Even if it was written more than 300 years BC, it still regarded as an important theory. Aristoteles defined the term rhetoric like this [11, loc. 110]:

“Rhetoric may be defined as the faculty of observing in any given case the available means of persuasion. This is not a function of any other art. Every other art can instruct or persuade about its own particular subject-matter; for instance, medicine about what is healthy and unhealthy, geometry about the properties of magnitudes, arithmetic about numbers, and the same is true of the other arts and sciences. But rhetoric we look upon as the power of observing the means of persuasion on almost any subject presented to us; and that is why we say that, in its technical character, it is not concerned with any special or definite class of subjects.”

Further, he divides rhetoric into three modes of persuasion, they of normally referred to as ethos, pathos and logos [11, loc. 122]:

“Of the modes of persuasion furnished by the spoken word there are three kinds.”

- *“The first kind depends on the personal character of the speaker” (ethos)*
- *“the second on putting the audience into a certain frame of mind” (pathos)*
- *“the third on the proof, or apparent proof, provided by the words of the speech itself” (logos)*

Persuasion is achieved by the speaker’s personal character when the speech is so spoken as to make us think him credible.”

Since Aristotle’s theories on rhetoric focuses on how a speaker can persuade an audience, it is connected to one special communication setting. In ancient Greece, a speaker had to presents his message verbally standing in front of them. This is a communication setting where the speaker’s voice and his visual appearance are the communication channels. Therefore, properties of these channels are investigated for optimisation. Still much of the same principles applies to other forms of communication. Other communication channels have other properties and should therefore be analysed with this respect. The application of the three modes of persuasion must be adapted to the communication channels. Description of the three modes given below is based on the verbal communication setting.

Ethos - the personal character of the speaker.

Aristotle argues that we believe in good men more fully and readily than others. He states that this is true regardless of which question that is discussed. When there is impossible to know the truth about the topic and opinions are divided, the character is even more important. He therefore put the character as almost the most effective means of persuasion that a speaker possesses. [28]

For the speaker to be credible Aristotle lists three prerequisites [28]:

- Competence
- Good intention

- Empathy

The audience may have an opinion about the speaker prior to his speech that influence his ethos. Several factors can be relevant e.g., the speakers rank, job position, education, authority, reputation, race, celebrity-status etc. Factors that determines his relationship toward his audience influence his ethos. It is important to notice that ethos is a dynamic factor that exist between the speaker and his audience. One group of audience can hold him credible while another audience can regard him as untrustworthy. His ethos within one group of people can also differ. With regard to persuasion, it is therefore important to be aware of the most important people (or group) to persuade. [28]

The subject (or message) can also influence the ethos. A specialist on security may have good ethos when he speaks of this subject. His ethos may be weaker when he speak about subject outside his field of expertise.

The audience may not have any prior knowledge to the speaker. Then he may need to include some statements into his speech that tells the public why his opinion matter and should be trusted.

In any case, his appearance when making his speech will influence his ethos. The actual vocal lecture with content is one aspect. Further vocabulary, slang, buzzword etc. will contribute. The use of his voice with vocal elements like tone, pitch, speed etc. is also a part. In addition will nonverbal factors like gesture, facial expressions, proxemics, body language and movement make an important contribution to ethos [28].

All factors that contribute to the speaker's ethos is relevant regardless of if he presents his character conscious or unconscious. Ethos determine if a speaker appear to be credible among an audience. Thus, it is the audience's mental image of the speaker, not the speaker himself. [28]

By being aware of factors that contributes to a good ethos, a speaker can practise impression management. The goal of this effort is to appear trustworthy and authentic based on his character alone (and not his arguments). Since the audience will receive, cue of his ethos through different channels (verbal, nonverbal) it important with congruence. Even if the audience receive some of these cues on a subconscious level, it influences their trustworthiness perception. [28] Research done by Albert Mehrabian described in [29] indicate that when a communicator speak about his feelings and attitude, the nonverbal cues will have the strongest impact on the audience. He describe the relative importance of verbal and nonverbal importance with this formula: Total Liking = 7% Verbal Liking + 38% Vocal Liking + 55% Facial Liking. It is important to notice that Mehrabian research often have been misinterpreted to be valid in other communication settings. He therefore state on his website [30] that:

“Please note that this and other equations regarding relative importance of verbal and nonverbal messages were derived from experiments dealing with communications of feelings and attitudes (i.e., like-dislike). Unless a communicator is talking about their feelings or attitudes, these equations are not applicable.”

Pathos – emotional influence the speaker have on the audience

The speaker can also use emotions to influence the audience by putting them in an appropriate emotional state. Aristotle therefore emphasise that the speaker must know which emotions that exists and how they can be elicited [11, loc. 1110]:

“The Emotions are all those feelings that so change men as to affect their judgements, and that are also attended by pain or pleasure. Such are anger, pity, fear and the like, with their opposites. We must arrange what we have to say about each of them under three heads. Take, for instance, the emotion of anger: here we must discover (1) what the state of mind of angry people is, (2) who the people are with whom they usually get angry, and (3) on what grounds they get angry with them. It is not enough to know one or even two of these points; unless we know all three, we shall be unable to arouse anger in any one. The same is true of the other emotions.”

The speaker must know their audience if he should be able to arouse their emotions. Their values and what they believe in can often be used for this purpose. By using techniques and presentation styles that creates or enhances emotions, the audience’s ability to be critical reduces. Certain use of language is best fit to create emotional reactions in the audience. E.g., they react differently to storytelling than a lecture style presentation. The speaker can also use exemplification or illustrations to elicit emotions. Use of different objects or a representation of them is another method. Since it is difficult to make people change behaviour, the change should be related to something the audience already believes. This approach is called an anchor and is effective because it represents something that is already accepted by them. “Anchors can be beliefs, values, attitudes, behaviors, and group norms.” [27, p. 33].

Pathos aim at reduce the audience ability to judge [28].

There are different view among experts of today about the importance of emotions in decision-making. The biologist Gerhard Roth claims according to [28] that most decisions are taken based on unconsciously and emotional processes. Therefore, he claims that “free will” is an illusion. If this is the case, pathos appeals may provide a strong persuasive effect. [28]

Logos – persuasion by content and logical argumentation

When the speaker use logos, he appeals to the logical reasoning among the audience. By providing arguments and proves or other content that support the arguments, he aim to persuade. Aristotle put it like this [11, loc. 131-132]:

“Thirdly, persuasion is effected through the speech itself when we have proved a truth or an apparent truth by means.”

To convince the audience the speaker should ideally prove that his arguments represent the truth. That could be to show that the presented facts corresponds to reality. The aim in also here to persuade the audience and an apparent truth may work when it is not possible to get proves. It is important to realise that Aristotle made a distinction between scientific and rhetorical proofs. While the premises are stated specifically in scientific proofs, they are built upon the disposition of the audience in rhetoric. The goal is to establish a relationship between the presented facts and the reality of the audience. [31]

“Logos deals with several aspects, which are concerned with the content, structure, and argumentation of a speech.” [31, p. 1]

The communication setting impose some limitation on speaker in ways he can express his message and for the audience’s perception. It is important that the speaker know that he may not fully use his expert knowledge in this setting. The audience are usually unable to control (stop or pause) the information flow in order to memorise or reflect about it. In this way, the rhetorical logical appeal in a speech is different from the one in a written argument. In speech, the arguments must be presented simple and clear so the audience is able to follow the reasoning. A clear structure assists this effort. The goal is that the reasoning appear sound to the audience. [31]

3.6.2 Influence through social psychology

Meriam-Webster define social psychology as “the study of the manner in which the personality, attitudes, motivations, and behavior of the individual influence and are influenced by social groups”. [32]

There are done a lot of research within social psychology and it reveal insight into effective ways to influence humans. Robert B. Cialdini describe six categories of persuasion techniques in [33]. Research has shown that these persuasion techniques can increase the success of persuasion efforts significantly. The six categories are reciprocation, commitment and consistency, social proof, liking, authority and scarcity. In the short description below the terms are explained in cases where a sender wants to influence the behaviour of the receiver. [33]

Reciprocation is about utilising human’s disposition to give something back to when they receive a gift. The sender initiate this technique simply by giving the receiver a gift. Even when the gift is small, it puts the sender in an advantageous position. The receiver feels indebted and are therefore in a position where he wants to reciprocate the gesture. Commitment and consistency take advantage of people’s desire to appear as stable and crafty persons. Commitment refers to the fact that people normally stick to an idea or cause after an agreement or promise have been made. When they have taken a stand, they want to be consistent with this decision in later cases. Social proof make use of human’s tendency to act similar as other people. When making a decision people tend to look after what other people think is correct before they determine their own point of view.

Liking in central for influence. If the receiver knows and likes the sender, he is much more likely to comply with the sender’s request. Humans tend to like other who share their interests, attitudes and beliefs. Authority describe peoples tendency to comply with requests from figures that appear to be authoritative. [33]

The scarcity techniques applies when something like a product, service or information appear to have limited availability. Then people tend to perceive these products as more valuable and desirable. [34]

There six categories of persuasion techniques may of course be applied within the context of Aristotle’s rhetoric. Some of them are also describe in [11] but are backed up by research in social psychology. It is appropriate to note that the human behaviour patterns that are described in the six categories serve people well in normal human relations. Yet a sender can exploit them if he forms a message that trigger an automatic (unconscious) response by a receiver.

3.7 Other factors of the effectiveness problem

The different subsections below refer to different perspective on the effectiveness problem of human communication (ref. Weaver's problem levels in section 3.4.3). Like various communication models, they may overlap, since they relate to the same theme. They all address the important human relation aspects.

3.7.1 Motivation

If a communication shall be efficient, it requires that the receiver(s) act according to the sender's intention. Imagine that the message has appeared at the receiver and that he has conceived the sender's intention (no technical or semantic problem). Still the effect are uncertain. The sender cannot be sure of the receiver is motivated to act in accordance with his intention. An insight into human motivation can reveal some factors that can be attended in order to succeed.

Su Mi Park Dahlgaard & Jens J. Dahlgaard refer to a qualitative survey on core values that were done on master students over a period of nine years (1992-2000) at the Aarhus School of Business in Denmark [35, p. 158]. The study asked the students to identify the most important factors when we work with others, and the most critical barriers that prevents cooperation between people. These core values were identified as the most important factors: openness, honesty, responsibility, trustworthiness, being positive, loyalty, respect and integrity. The following factors were identified as critical barriers: dishonesty (unreliability), irresponsibility, being negative, disloyalty, arrogance and egotism. [35] Since successful communication requires cooperation between people this insight is important for communication optimisation.

Trust is a vital part when it comes to communication. Many research results show that trust is a prerequisite for communication, dialogue and building people relationship.[35] Mishra state in [36, p. 268] that "Trust is one party's willingness to be vulnerable to another party based on the belief that the latter party is 1) competent, 2) open, 3) concerned, and 4) reliable." This willingness to be vulnerable is highly dependent on confidence in the other party.

According to [35, p. 154] do "Fukuyama (1995), Gambetta (1988), Putnam (1993) and Tyler and Kramer (1996) argue that relationships between people are deeper, and that people are more committed and more willing to engage in social exchange in general, when there is trust."

Dahlgaard & Dahlgaard claim in [35] that even humans undertake a lot of different activities that are varied and different, the underlying motivation for these activities seem to be few. They reduce these drivers to three concepts (the three Ls): Living, Learning and Loving. Living represents the physical or biological needs; Learning is about the mental or psychological needs and Loving cover, the spiritual needs or core values. Existing frameworks of human motivation usually cover the living and learning aspects, while loving is a new diminution in Dahlgaards's framework. With respect to motivation, it is interesting to identify how the different desires can be fulfilled. For the physical or biological (Living) needs there can be produced material objects like food, clothes and houses. This are normally referred to as extrinsic motivation. [35]

The mental or psychological (Learning) needs cannot be obtained by procuring anything external. Mental satisfaction is achieved by exploiting internal resources through actions

like learning, studying etc. Spiritual needs or core values (Loving) could be charity, modesty, honesty, respect for others, trust, loyalty, fairness and justice. Learning and Loving are here referred to as intrinsic motivation. [35]

Theoretical and empirical studies in [35] suggest that these three different needs exists simultaneously, side by side and not in the layers presented by Maslow in [37]. Dahlgaard & Dahlgaard argue further that the Living needs are generally met in well-established industrial countries. Consequently, the Living (biological) needs are interrelated with the Learning (mental) needs. People purchase material things like houses, not just to get shelter but also to reflect their social status. However, to create optimal motivation it is necessary to recognise all the three needs. Dahlgaards's framework called "The Trinity Model" lists elements of these different needs.

Physical or biological needs (living)	Mental/psychological needs (learning)	Spiritual needs or core values (loving)
Food	Sense of belonging	Searching and creating meaning
Water	Friends (mental love)	Trust
Air	Sex (mental love)	Justness
Shelter	Recognition	Honesty/openness
Clothing	Individual identity	Loyalty
Safety	Achievement	Integrity
Sex (biological)	Learning	Charity (Spiritual love) and sharing
	Creativity	Fairness
	Development	Respect
	Self-fulfillment	

Table 2: The Trinity Model of human needs from [35].

An individual has some internal skills or means to fulfil his mental or psychological needs. These capabilities are denoted core competencies in [35] and is subdivided into two main areas namely Emotional Competencies (EC) and Intellectual Competencies (IC). EC is traditionally connected to the term sensibility which involves the application of the human senses to see, listen, taste, feel, sense, pay attention (be aware) etc. Therefore, EC represent interpersonal skills important like emphatic listening, dialogue, etc., prerequisites for successful communication. Humans with little or no EC will have serious trouble in understanding other people. While EC involves sensing and feeling, IC implies reasoning with humans logical and rational capabilities. These skills are typically required in areas like mathematics and technology. EC and IC represent two principal different ways to obtain knowledge – the empirical way and the rationalistic way. For a long time people's emotional aspects (EC) have been downgraded or ignored. School grades and IQ tests are normally focus on IC capabilities. However, several newer research argues that EC is the strongest determinant for human success. [35]

Core values (loving) is believed to be 'encoded' in all human beings as a part of their human nature. Being 'fair' or 'good' are thus innate human desires. Since core values are universal and unchanging, they are a part of the natural law. McEwan claims according to [35] that people who live in harmony with their natural inclination will attain a higher level of satisfaction.

In summary Dahlgaards's framework called "The Trinity Model", illustrate three categories of human desires (motivators). Physical or biological (Living) leads to extrinsic motivation while mental or psychological needs (Learning) and spiritual needs or core values (Loving) cause intrinsic motivation. When a person shall be motivated e.g. to do a task, his inner state is interesting. With extrinsic motivation, he will do the task as a necessary duty to receive his reward (motivators like salary etc.). Contrary in intrinsic motivated situation the person perceive the task itself as 'giving', and identify himself with the task. Then he feels that task itself is a reward and is worth doing for its own sake [35].

3.7.2 Connection

John C. Maxwell uses the term connection in [38] to describe properties of the relationship between the sender and the receiver. He states that connection is a prerequisite for communication to take place. The sender needs to maintain a connection with the receiver to get his message through. [38]

The discussion here is about the effectiveness problem of the communication (not the technical or semantic). Even so, it can be useful to think about a technical connection to grasp the importance of the connection. Consider a telephone conversation between two people where the sender shall give a simple message to a receiver. If the technical connection is good, the receiver will easily hear the words from the sender and the message gets through. In another cases, there may be occasional noise on the line so it is difficult or impossible for the receiver to take in the words. Then the sender might need to repeat parts of his message one or several time to make it possible for the receiver to get the words and understand the message. A bad connection requires more energy from both parties to achieve communication. This leads to frustration and low efficiency. If the receiver's initial motivation is low, the connection problems may ruin his patience and the communication fails.

Connection related to the effectiveness problem, is about inter-human relations. For this discussion, we assume that the words flow easy from the sender to the receiver without any technical problems. Still the sender (the person) needs to connect to the receiver, to achieve communication. The quality of their interpersonal connection determines the efficiency. A bad connection disrupt the communication and undermine the efficiency.

Therefore, it can be said, "connecting is everything when it comes to communication." [38, loc. 52]

Almost every human being are overwhelmed by messages from different sources that tries to get their attention. Colleagues, advertisers, salespersons, family members, friend and others all have something to say. In our modern society, the number of channels they can use to approach the receiver is increasing. E-mails, instant messaging, blogs, Facebook, Twitter, Skype, television, radio, telephones, billboards, newspapers, magazines and books are some possible channels. Many of these channels are ubiquitous, so the receiver must select among the huge amount of messages. A sender needs to connect to the receiver to achieve successful communication. [38]

"Connecting is the ability to identify with people and relate to them in a way that increases your influence with them." [38, loc. 116]

Different settings requires various approach for connecting. To adapt the connecting effort to the situation, three different levels are described by Maxwell: one-on-one, connecting in a group and connecting with an audience. [38]. The one-on-one connection are considered most important according to Maxwell since 80-90% of all connections happens at this level. You connect with the people that are most important to you at this level. Maxwell's general principles for connecting is to sincerely recognize the value of other people and focus on them, not yourself. It is important that they perceive that you genuinely care for them. Further, you must show that you can provide something useful for them and that you can be trusted. Everything you convey must be heartfelt, since your attitude often speaks louder than your voice. [38]

"To add value to other, one must first value others." [38, loc. 548]

Some of Maxwell's further recommendations from [38], for improving connection and thus the communication is described in the remaining part of the section.

To improve the connection one-on-one you should ensure that you talk more about the other person and less about yourself. If you see yourself as the centre of the conversation, you will not connect. By listening, you can learn what they value and ask them why they value those things. When you share your values that correspond to theirs, your relationship can be built on common values. [38]

It also help to bring something of value when you come together. This do not have to be some expensive material gift but can be a helpful quote or a nice story. Offering help or service and seeing it through, strengthen the relation more than is possible with words. [38]

To improve connection within a group it is necessary to take initiative with people within the group. By inviting the other to participate with their ideas, they feel valued. Find natural ways to praise people in the group for their ideas and actions. Try also to add value to people in the group. It is further important to not take credit for the group's success or cast blame when it fails. [38]

To connect with an audience it is important to let them know that you are inspired to be with them. They should also be told that you wish to add value to them. This can be done by preparing some special content for them. If suitable, you should also describe why they or their organisation is important to you. It is uttermost important to let the audience know that they are the most important part of the session, not you or your content. [38]

To be credible you must own the message you seek to convey. Even if it is not your own originally, it is uttermost important to make it your own before you try to pass it on to others. Conveying your own message strengthen your credibility. [38]

"Any message you try to convey must contain a piece of you." [38, loc. 777]

To connect with others it is necessary to be intentional about it, and that always require energy. You must be willing to bring the energy and choose to use it while you reach out to

others. Intention is required if one should be able to generate energy for the communication. The larger the audience, the more energy is needed to connect. Avoid taking any connection for granted, even with people you know. Preparing yourself mentally and emotionally requires energy but improves the connection. It is important to be aware that a larger audience expect to receive and not give, when they attend an event or a conference.

A good communicator must be a giver and not a taker of energy. The speaker's mode reflects his mind-set. A giver is selfless, while the taker is selfish. By bringing the body language, brain and personality into the communication, energy is given to the receiver. Conviction that comes from preparation, passion that comes from conviction and positivity that comes from a believing in other people all contributes to increased energy. [38]

"The only thing that keeps a man going is energy. And what is energy but liking life?"

- Louis Auchincloss

3.7.3 Pragmatic human relations

This section will elaborate of some pragmatic thoughts on human relations. These insights are not new science, many of them have been known since ancient times. Yet, they are often forgotten, although their impact on human communication are tremendously. The reflection on this topic below is based on [39] by Dale Carnegie.

It is very important to consider the relationship between the sender and the receiver when communication shall be improved. When we study a technical relation like computer-to-computer communication the sender and, the receivers are both material objects. Then there is possible to predict precisely how the receiver will react on a certain message when we know the properties of this object. A group of similar configured receiving objects will treat a message the same way and yield the same result.

A human-to-human communication is a human relation where the sender and the receiver are subjects. Since human beings are unique, it is harder to predict how the receiver will interpret a message, and which result it cause. An identical message may lead to completely different results when it is delivered to two different receivers. On the other hand, a receiver can treat an identical message completely different when it arrives from two different sources. These things make subject-to-subject communication completely different from object-to-object communication. Dealing with objects it is sufficient to consider logical aspects, while emotions might may be most important factors when humans are involved. The further discussion focus on human relations and do not consider the semantical problem.

Since the relationship between the sender and the receiver, strongly influence the efficiency of the communication, there is important to understand human nature. A relationship between two humans is not made by chance. When you understand some common aspects of human nature, you are better able to improve relationships and thus improve your communication. The sender and the receiver may be acquainted prior to a communication, and then there already exist a relationship. Therefore, it is important to be generally aware of relationships, since established relationships will form the basis when you communicate. [39]

To understand a human there can be useful to look at the concept of self-esteem. According to Eckhart Tolle, people normally maintain a mental image of themselves. Here we use the concept ego to denote this mental image. Ego is then a person's sense of self-esteem. Even if this ego is just a self-created mental image, many people think this ego is their identity, who they really are. [40]

Therefore, it is a very important concept to understand. All humans like to feel good about themselves. When their self-esteem come from their ego, the status of their ego will determine how they feel about themselves. Consequently, they will be motivated by actions that preserves or strengthen their ego. In general there are some factors that lead to a strengthen ego. The need to be important, intelligent, good and unselfish are examples of such factors. What factor that is most important may however vary between individuals. Some people may feel important due to their work, wealth, material possessions, education, power or achievements in some activity. Others may get a strengthen ego by performing unselfish activities to serve others. A strengthen ego may thus represent an individual's pride and dignity but may also lead to vanity. For the further discussion, it is sufficient to note that most humans are concerned about their ego and are motivated by actions that strengthen their ego. Contrary they will avoid situations that may weaken their ego. When their ego get stronger, they feel better and they feel bad when their ego is diminished. They are thus motivated by factors that make them feel better.

When we speak with anyone, our communication can influence the ego of the receiver. If we attack the receiver's ego, it is likely that we will reduce the effectiveness our communication. There are several ways to diminish a person's ego. By criticise, judge, condemn, complain or punish them we will hurt their self-esteem. We also reduce their ego by talking down to them e.g. by saying, "I am right and you are wrong". Even when you try to convince someone against his will, by "winning" a logical argument, you may end up losing. When you hurt someone's ego, you may lose every opportunity to influence his behaviour. If the sender holds a power relationship towards the receiver, he may obtain compliance while he can supervise the latter's action. When the receiver's motivation only stem from this authority and goes against his own feeling, the effect will most likely cease when he is not watched. [39]

Research in sociopsychology support this assumption [33]. It suggest that positive motivation measures are more efficient than punishment.

Therefore, the wise sender should apply positive incentives to improve his influence. By showing encouragement, approval and sincere appreciation, he will improve the receiver's ego and strengthen his own ability to influence the latter. It is however important to note that superficial flattery will not contribute to a positive outcome. Any statement or action towards the receiver must be sincere and heartfelt. This do not imply that one has to like every aspect of another's actions or ideas, but consciously choose to focus on the best parts. This is only possible when one obtains the right attitude and are willing to put aside his own ego. [39]

4 Analysis of communication factors

The wide-ranging theories on communication discussed under related work section forms a solid base for the study of communication optimisation. In order to make the material useable it is necessary to analyse the content and arrange it way that make it easy-to-understand. This section will seek to elicit the most important factors that should be considered for communication optimisation.

4.1 Analysis of communication models

The different communication models reveal different aspects of the communication process. This section is an analysis of the most important factors that these models provide. Different models use various terms. The terms speaker and sender are used for the person that originate the message. The terms subject and message are used for the meaningful content that the speaker wants to pass on to the hearer. The terms hearer, receiver and audience are used for the person(s) that are supposed to get the message.

Aristoteles provides a simple communication model with a speaker, a subject and hearer. He emphasises that the hearer is the most important and the key that determines if communication has taken place. Since communication is to make the subject common between the sender and the hearer, the latter must have perceived the message before we can say that communication has taken place. [11]

Lasswell add the concept that the message can be transmitted through different channels on its way from the sender to the audience. He also emphasise that an effect must have occurred before we can call it communication. [12]

From Shannon and Weavers model in [13], we learn that noise can disturb the message on its way between the sender and the receiver. Noise can denote anything that disturbs the message so it becomes incomprehensible for the receiver like e.g. semantic noise. It can also be useful to use the distinctions between the technical problem, semantical problem and effectiveness problem when communication shall be analysed. [15]

Schramm's models shows that the sender encode the message into a signal and that the receiver must successfully decode it if the message shall be perceived. The sender and the receiver must have overlapping field of experience if the message shall be fully understood. It is only in this overlapping field of experience that communication is possible. Schramm's third model introduces two-way communication. Here sender can be the receiver and the receiver can be the sender. This feedback loop makes it possible to verify that the receiver understood the message in the way that the sender intended. [16]

Rileys's model goes further into the ways social structures influence how the messages are

encode by the sender, and decoded and perceived by the receiver. [18]

The Johari Window model points out how the sender's knowledge about himself and the receiver's knowledge about the sender influence the ability to communicate. The best environment for communication occur when the individual's attitude, behaviour, emotions, skills, feelings views and motivations are known to oneself and others. The model also show that the communication environment can be improved if communication partners increase their knowledge about each other. In connection with the other models this model focus on how the encoding and decoding process can be better and thus remove semantic noise. [20]

The AIDA model from [23] has its origin in marketing communication. It therefore has a somewhat different focus than the other models. Since the receiver's in this case is not necessary motivated to listen on the message, it initially focus is on obtaining their attention. When attention is gained, it tries to keep the audience interested in the message and convince them to act accordingly. If the receiver's side of our communication model lacks motivation, this model can help to shape the message to enable successful communication.

As a summary the various communication models adds different insight into the communication process. This is valuable in the further optimisation study. With a mental picture of the process, it is easier to identify factors that influence the communication.

4.2 Important insight from communication models

This section will discuss factors that influence the communication process. The factors are identified from the communication models and theories in section 3.

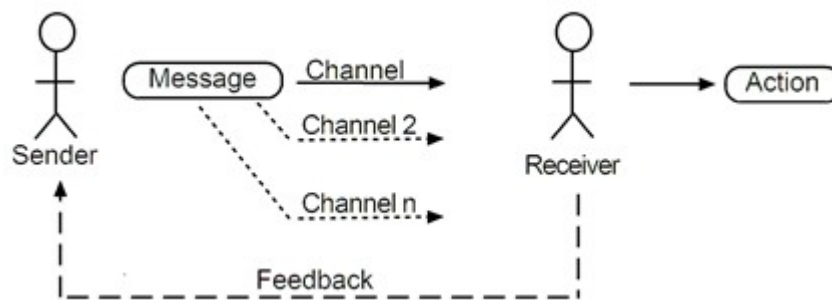

Figure 09: Simple communication model with channels and feedback

The figure above is inspired by Lasswell's communication model in [12] but the name of the labels are modified. It has also added a feedback loop described by Schramm in [16]. The communication process as we discuss here consists of a sender who wants to influence a receiver in a certain way. The figure above show some of the involved elements: The sender, the message, and one or several channels that transmits the message, the receiver and the action (the receiver's action after receiving the message). There is also indication of a feedback from the receiver to the sender. One way to look for factors that can be

optimised is to focus on each element in the chain: Sender, Message, Channel, Receiver and Action (behaviour). The sender has certain properties that influence the process. A closer analysis of the sender may reveal improvement factors. The message can also be a separate object of investigation. There are plenty of ways to form a message and each form will lead to different results. The channels may also be different. One channel could be a verbal face-to-face presentation of the message, while other channels could be e.g. telephone or video calls, traditional mail, e-mail, chat etc. Since the action performed by the receiver is the purpose of the communication, the receiver deserves the primary attention. The action (or behaviour) that the receiver perform because of the communication is also an interesting object for study. Whether it is possible for the sender to observe the action of the receiver will depend of the situation. When he is able to this, he can then be able to evaluate his own communication and improve it. In cases where there is a feedback from the receiver to the sender, there is also an increased possibility for successful communication. Then the receiver is able to verify any obscurities in the message.

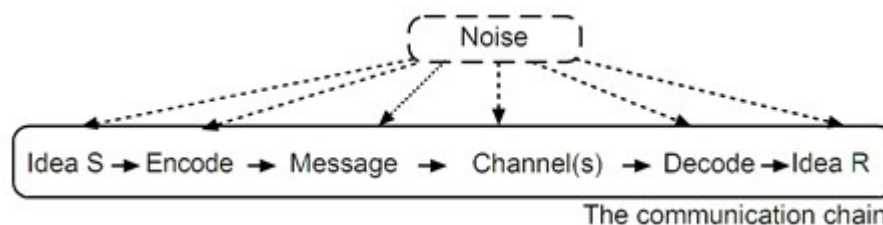

Figure 10: The communication chain with noise

The figure above illustrate some other aspects of the communication process. It is inspired by Lasswell's model [12], Schramm's models in [16] and the concept of noise from Shannon and Weaver's communication model in [13].

Initially the sender has an idea (Idea S) in his mind that he wants the receiver to receive. The sender needs to form his mental picture into a message that can be transmitted to the receiver. This could be done by encoding his mental picture into words and sentences, which he transmits through the channel (air) by speaking the words in front of the receiver. When the receiver hears the words, he must decode the words so he gets his own mental picture. From this, it is obvious that the sender's idea can be encoded in several different ways. It is usually possible for the receiver to decode the message into different mental images (Idea R). If $Idea R = Idea S$, then the sender has managed to make his idea intelligible for the receiver. A vital point is to observe that noise can interfere with all parts of the process. The sender can get disturbed so his initial idea becomes unclear. If the Idea S is unclear, it should be corrected before the communication is started. Noise in the encoding part indicates disturbances when the idea shall be converted into a presumably intelligible message. When the message is transmitted in a channel to the receiver it can be deteriorated by noise. E.g., noise from other people can interfere with the speaker so the receiver misses some of its content. Unawareness from the receiver, may also lead to corruption of the message. Interference in the decoding process with the receiver can lead him to an incorrect mental image.

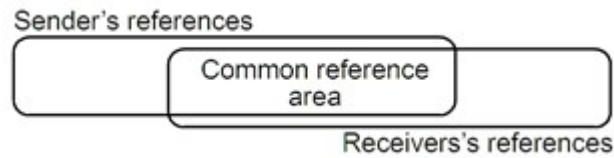

Figure 11: Common reference area

The figure above focus on the semantic relation between the sender and the receiver. It is inspired by the discussions about the ideas that the sender and the receiver need to share some fields of experience as Schramm expresses it in [16]. Rileys's model in [18], Luft and Ingham model in [20] and Weaver's semantic problem in [15] also discuss this issue.

All individual human beings have their own unique perception of the world. Therefore, they may interpret similar words differently. There will also be different words and terms they are familiar with based on different experiences. People that know each other will have a larger "common reference area" than people that are unacquainted. People who do not share language or culture have a smaller "common reference area". This concerns the encoding and decoding processes of the communication. Even if a message is received 100 % complete and correct at the receiver's side, it may not be intelligible for him if it contain words outside his reference area (field of experience). The receiver may also interpret some of the words differently and end up with a message that not correspond to the sender's intention. The sender must be aware of this when he encode his message. He needs to use terms and explanations within the "Common reference area" if the receiver shall be able to decode the message as intended. Still he must be aware of possible misinterpretations.

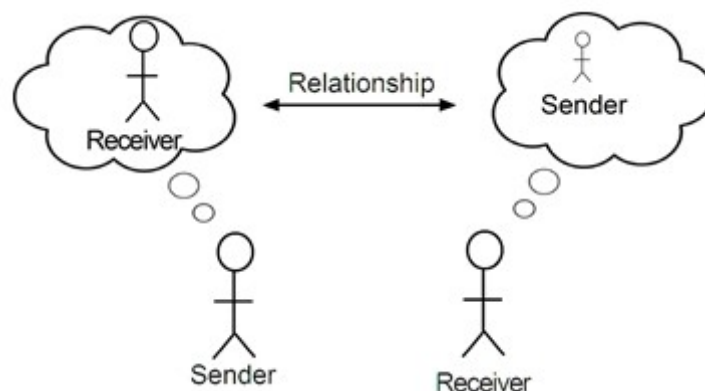

Figure 12: Relationship between sender and receiver

The figure above highlight the relationship between the sender and the receiver. It seek to

indicate that in this situation, the sender has higher thoughts of the receiver but it is not mutual. The receiver has a lower mental image of the sender. This unbalanced relationship will make it difficult for the sender to obtain his purpose of communication, especially if the message goes against the receiver's interests.

The relationship between the communication partners has the uttermost importance. A bad relationship may render all communication effort useless. The receiver may ignore a clear idea, even if it is perfectly encoded within the "common reference area", if he do not like the sender.

In other cases, there may not be any known relationship between the sender and the receiver(s). In a mass communication, there is a particular challenge to make the public listen to a message from an unfamiliar sender. The sender then need to catch the receiver's attention uninvited and arouse their interest, so they are motivated to receive the message. The importance of relationship could not be underestimated. Independent of all the other aspects of the communication process, the relationship will always influence the outcome.

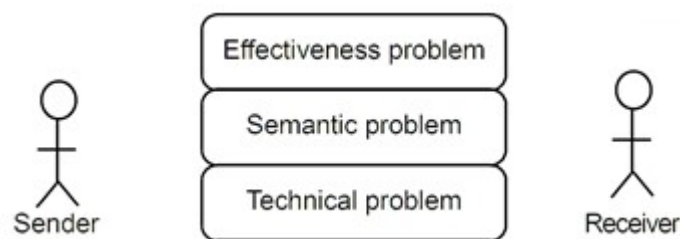

Figure 13: Communication problems to overcome (visualisation of Weaver problem levels in [15])

The figure above highlight Weavers perspective on the communication problem levels [15]. These levels can be used further in our communication analysis. From figure 09 (Simple communication model with channels and feedback) it can be observed that the communication can happen through several channels. Each channel will then have its own set of technical problems. E.g., a transmission between two radios transceivers will have different set of technical problems than a line based telephone transmission. In addition to the technical problems, each channel will have its own set of semantic problems. E.g., when the sender shall encode his intention into a textual message, it will be a different set of semantic problems than if he encode do the same intention into a verbal message. Even if each channel may have different sets of technical and semantic problems, some of these problems may be common. If the sender tries to formulate his ideas with terms that are unfamiliar to the receiver, it will represent a common semantic problem independent of the communication channel. The effectiveness problems address the outcome of the communication. Even when the sender is able to convey his intention equally clear through two different communication channels, he might observe that the effectiveness is different. E.g., the receiver may decide to ignore his e-mail message, while he choose to act directly on the same message verbally received in a face-to-face meeting. For all the three problem levels there must be recognised that the degree of success do not have to be 0% or 100%. If noise on the line distort a conversation, the receiver may still understand the sender's intention partially or completely. Lack of knowledge about some terms is a corresponding example on the semantic level. On the effectiveness problem, the receiver can choose to comply with the sender request for a short period. When the sender intention was a

permanent change of conduct, then the communication has only been partially effective. The figure 09 also indicate a possible feedback loop from the receiver to the sender. Feedback can be used to correct problems in any of the three problem levels. The feedback is really a reverse communication, when the receiver become the sender and vice versa. The context is however a reply to the received message. Problem solving through feedback may be done on different problem levels. If the technical transmission fails, a retransmission can be generated without the knowledge of the sender. In other cases, the receiver can appeal for a better explanation, if he does not understand the message. On the effectiveness level, the sender may ask the receiver for a feedback when his request is fulfilled. There will not always be practical or possible to have feedback possibilities. A common problem in communication is that the sender are not able to verify the effectiveness. When he is unable to monitor the effectiveness of his communication, it is more difficult to improve it. Still it seems reasonable to apply best practises recommended from communication experts and researchers. Although humans are different, they have often have some common traits that can be addressed for improved communication.

The figure 10 (The communication chain with noise) illustrates that “noise” can appear in all part of the communication chain. Here “noise” is used as a common term for problems in any of the three areas (technical, semantic and effectiveness).

The figure 11 (Common reference area) is way to illustrate a part of the semantic problem. Every individual human have his own unique reference area. The degree of overlapping reference areas with other persons determine the common reference area. To reduce the semantic problems the communication should be performed within this common reference area. Yet it is important to be aware of the possibility for semantic problems, even when all communication is kept in the common reference area. By defining the context as an initial part of the communication, the sender can direct the receiver’s attention towards the current issue and thereby reduce the possibility for semantic problems.

The figure 12 (Relationship between sender and receiver) highlight important aspects of the effectiveness problem. It is reasonable to assume that a relationship based on mutual trust and respect will strengthen the effectiveness of the communication. Contrary will a strained relationship reduce the effectiveness or even make communication impossible. The power relationship between the sender and the receiver can also influence the effectiveness. If the sender hold authority towards the receiver (e.g. as a supervisor), it may strengthen the effectiveness. This is the case especially when the supervisor can observe the action taken by the receiver (the effect of the communication). Then the receiver may choose to act according to the request, to avoid negative consequences or gain positive consequences. In many cases there will be impossible or inefficient for the sender to observe the receiver’s action. Then the effectiveness must be based on other means than authority.

The receiver’s motivation to act upon a request depends on several factors. It is possible to assume that all humans act out of self-interest. They choose to act in a way they perceive will make them feel better. Even if this should be true, it is hard to determine how they will act, since each individual is unique. Psychological research give some insight into normal behaviour pattern. It cannot determine with absolute certainty how an individual will act in

a given situation, but it can describe how most people act most of the time.

The relationship between the sender and the receiver is anyway important for the effectiveness of the communication. A mutual trust relationship that serves both the sender and the receiver is assumed the best foundation for effective communication.

4.3 Mental model for communication optimisation (Metacom)

Much of models and theories on communication overlap in content even if they focus on different aspects. In order to structure the factors that influence the communication it is useful to visualise it in a model. Then it is easier to get an overview over the different factors and understand which aspects they address.

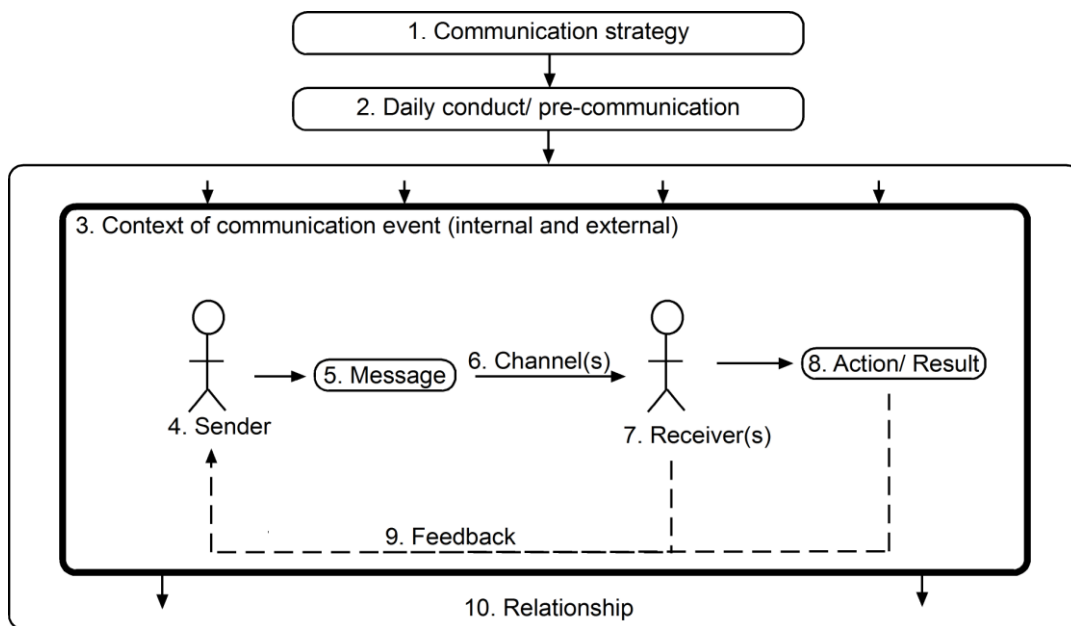

Figure 14: Mental model for communication optimisation (Metacom) by Sveen 2016

The figure above illustrate some important factors relevant for communication optimisation. It is designed with inspiration from communication models of Aristotle [11], Laswell [12], Shannon and Weaver [13], Schramm [16], Rileys [18], Luft and Ingham [20]. It also seek to cover important aspects from communication theory like Aristotle's rhetoric [11], propaganda by Bernays in [24] and Goebbels in [26], social psychology by Cialdini [33], motivation psychology from Dahlgaard & Dahlgaard [35], connection by Maxwell [38] and pragmatic human relation by Carnegie [39]. It seek to integrate important factors from models and theories without being too complex.

The different factors are numbered to for easy referencing. There is of course possible to communicate without considering the communication process itself. Yet this study claims that efficiency improvements can be made by being conscious about the communication. When the further discussion on in this thesis refer to the factors in Metacom, they are written capitalised.

When communication shall be optimised, different factors influence the efficiency in different ways. In Metacom, there are listed ten factors to consider.

1. Communication strategy
2. Daily conduct/ pre-communication
3. Context of the communication event (internal and external)
4. Sender
5. Message
6. Channels(s)
7. Receiver(s)
8. Action/ Result
9. Feedback
10. Relationship

The first two factors (1 and 2) are general and not related to a specific communication event (strategic communication). The factors 3 - 9 are considered within the context of a specific communication event (tactical communication). The last factor (10) address the Relationship between the Sender and the Receiver(s).

In order to improve communication efficiency there is not required to consider every factor. Every communication event is different. It is not possible nor desirable to a complete communication optimisation analysis prior to any event. Sometimes there is not time for preparation, while other events can be planned in detail. The importance of the event may also determine the effort that are possible to invest in the preparation. Current literature like [38] claims conscious effort to improve communication will mature over time. Then some of the techniques may be internalised and works without further considerations. One should be aware that factor 1 and 2 are general and unrelated to a specific communication context. Therefore, the effort invested on this level will contribute to increase efficiency in every context.

The literature on communication seems to agree upon the Receiver(s) (factor 7) as the most important factor, since he/(they) determine the end (i.e. Action/ Result). Attention on the Receiver(s) should therefore always be prioritised when it comes to communication optimisation.

There are also different tools that can be utilised to adjust the different factors in a way that influence the communication efficiency. Some tools relates to just on factor but other tools may work on several. The term tools are here used a metaphor for different methods that can be used.

Below is a short discussion of the factors:

1. Communication strategy.

This factor consider the fact that we often have some long-term goals with our communication. Our company or unit may have some preeminent objectives that we want to communicate to our surroundings. If the company want to be perceived in a certain way by the Receiver(s), the Communication strategy should support this goal. We as individuals may also have similar goals for ourselves. If we want to be perceived in certain ways by other people, the Communication strategy should also be adapted accordingly. The Communication strategy should be used as a guide for our Daily conduct/ pre-communication.

2. Daily conduct/ pre-communication

We always communicate to our surroundings; even we not actively participate in a communication. This applies to both an organisation and an individual. People will form an opinion on us based on our daily conduct. Since these persons may be our communication partners (the Receiver(s)) at a later point, their opinion may be vital. Their perception of our company or us as individual influence Relationships and, may determine our ability for effective communication.

By being aware of our pre-communication and behave in accordance to the Communication strategy, we can build Relationships as the foundation for efficient communication.

3. Context of the communication event

All communication happens within a Context. It is obvious but that does not imply that every Sender is aware of it. Everyone communicates a lot and it is not possible to analyse every casual communication situation. On the other hand, several important communication situations are arranged in advance. That makes it possible to identify the Context, so the communication can be adapted to the situation. This is a vital optimisation effort. It is useful to observe that context often is surrounded by an established Relationship between the Sender and Receiver(s). Then the Relationship will heavily influence the communication as the four arrows on the top indicate.

The Context factor frames a specific communication event. No communication event are identical and it is important to be conscious about the Context to do any optimisation. The Context defines the rationale for the communication event and frame factors. It can be useful to divide the Context in two parts namely external Context and internal Context.

External Context is not about the communication event itself, but it surroundings. E.g., there might be current events in the company or in the news that influence the audience prior to the communication event. It is important to be aware of circumstances that define the external Context. Then it is possible to predict how it can influence the communication and if possible use it to improve the efficiency. If the schedule for the event is fixed, it can be efficient to adapt the Message to fit into the situation in the surroundings. Without a fixed schedule, it might be efficient to choose a time that fits the Message.

Internal Context is about the communication event itself. Factors 4-9 are specific for the internal Context. In addition, duration is an element that requires attention. Sometimes the duration is fixed. Then it forms a delimitation of the communication event and the Message must be conveyed within this period. Without a fixed duration, the Sender may define a suitable period for the event. The prior Relationship between the Sender and the Receiver(s) is a part of the internal Context. The communication event will also influence the Relationship as the two arrows in the button indicate.

4. Sender

The Sender is here the one who performs the communication. He is responsible for creating the Message and conveying it to the Receiver(s). To create means to encode an idea into a Message.

As the analyser of the situation, you might be the Sender of the information yourself, but it must not be so. If you are a manager within a unit, you may delegate a presentation (the communication event) to one of your subordinate. You should then choose the employee that is best suited to convey the Message. This is of course related to the Relationship factor.

In a face-to-face communication, the Sender must always be aware of his non-verbal communication. The non-verbal communication can be regarded as parallel Messages, to the one he expresses in words.

The Sender is responsible for the communication, and is therefore the person that should apply communication optimisation techniques. Within the context of this thesis, the Sender is the security professional.

5. Message

The Message is the entity that contains the information that shall be passed on to the Receiver(s).

Since the Message must be created based on an idea of the Sender, some considerations should be made in advance. It is important to make a clear statement about the goal(s) for the communication event. This implies a clear thought about the idea you will pass on to the Receiver(s) and a description of what you want to obtain as an Action/ Result (what you want the Receiver(s) to do/ understand).

The Message should also comply with the Communication strategy.

The Sender should be aware of what charge it implies for the Receiver(s), to perform the intended Action/ Result, which is carried by the Message. It is easier to make the Receiver(s) perform an Action/ Result, which requires just a small effort. On the other hand, it can be very hard to get the intended result, when the request places a heavy charge upon the Receiver(s). Therefore, the sender must invest more energy into a "heavy" message than a "light" message.

6. Channels(s)

The Channel(s) represents the medium that carries the Message from the Sender to the Receiver.

There can be used several possible Channels to convey the Message. In a traditional

presentation, the Sender may use his voice to deliver a Message to the Receiver(s). At the same time, he will transmit non-verbal cues through other parallel Channels (e.g. body language (visual Channel), voice, pitch (audible Channel)), whether he is aware of it or not. Simultaneously he can use a visual channel (PowerPoint presentation) to support the Message.

The Sender may choose the Channel or several Channels that are best suited to convey his Message to the Receiver. Options may be restricted by the Context or other frame factors like economy.

7. Receiver

The person or the audience that the Message is intended for is called Receiver(s) in Metacom. Since the Receiver(s) is the most important factor in the communication, it is wise to gather some information about him/ them in advance. This information is important when the communication event should be optimised.

The approximate number of Receiver(s) is always important to know. In some cases, the number of Receivers at an event is low and you know them beforehand. In other cases, it is difficult to obtain specific information about the Receiver(s). Still there is often possible to obtain some general information about them in advance. General knowledge about humans is important when communication shall be optimised for the Receiver(s).

It is important to note that the Receiver is the person (or persons) that the Message is aiming at. The person you address is not necessarily the Receiver. This can be exemplified with a TV-discussion between two politicians. Their argumentation is not made to convince the opposite part. The goal is to convince the audience. Then the audience are the Receivers in terms of Metacom.

8. Action/ Result

Action/ Result denotes the outcome or result of the communication. It determines if communication has taken place. The Action/ Result is of course closely linked to the Receiver, since he is the one performing it. Many communication events may not lead to an observable Action. The Message could be plain information that the Receiver may use at some later point. Then the Sender may never know if his Message was received and understood as intended. It is also important to acknowledge that establishment or modification of Relationship(s) may be the sole purpose of communication.

9. Feedback

The Feedback factor indicates the possibility for the Sender to get some response on his Message. Some communication events make Feedback possible, while other makes it unlikely or impossible. When Feedback is possible, the Receiver can ask the Sender to clarify his Message if necessary. The Sender also has the possibility to verify if the Message is handled according to his intention. The Feedback indicated from the Action, indicates that the Sender himself can verify that the Action is performed. The Sender can also interpret non-verbal cues from the Receiver(s) as Feedback. E.g., if everyone is sleeping his communication probably not effective.

10. Relationship

The Relationship between the Sender and the Receiver(s) is a very important factor when it comes to communication efficiency. The term Relationship is here used in a broad sense. Even if the Sender and Receiver never have met, they may have some predisposed opinions about each other. These opinions is here regarded as a part of the Relationship factor.

In the Metacom model, the Relationship is shown as a box that surrounds the communication event. Daily conduct/ pre-communication establishes and modifies Relationship(s). In many cases this Relationships make up a major enabler or blocker of for a specific communication. A favourable Relationship can make it possible to obtain Action/ Result even when the Message places a heavy burden on the Receiver(s). Contrary a bad Relationship can block any communication attempt. (The four arrows pointing from Relationship down to the Context indicate this influence).

In other cases there may not exist any Relationship between the Sender and the Receiver(s) prior to a communication event. Then some kind of Relationship will be established and develop through this experience. In any case, every communication event has the possibility to influence the Relationship between the Sender and the Receiver(s). Most of the other factors in Metacom will influence the Relationship. (The two arrows pointing from the Context down to the Relationship indicate this influence. It is assumed that the Relationship factor usually influence the Context (communication event) more, than the Context (communication event) influence the Relationship. This is the reason for using four arrows for the former and two arrows for the latter).

The Sender can work on the Relationship to improve communication efficiency towards Receivers.

4.4 Analysis of propaganda for public relation (PR)

Propaganda is used for communication to the masses. Its methods aim to influence effectively a larger audience. [24]

Propaganda is a loaded term. It should be avoided since it arises negative emotions. In the further discussion, the term public relation (PR) is used. Whether propaganda and PR are synonymous is a controversial issue, but they both seek to influence public opinion. Since the purpose within this paper is to research different ways to leverage efficiency with optimised information security communication, the sinister and deceptive part of propaganda methods is considered unethical and thus not relevant. Within this frame, PR should be an acceptable term when we discuss different optimisation methods.

The propaganda section from chapter 3 is here analysed and relevant methods and ideas are related to the factors in Metacom.

1. Communication strategy

The rationale behind PR is relevant for an individual security professional, an information security unit (IS unit) as well as for any company. The IS unit is used in the further discussion, but the same principles applies to all the above-mentioned entities.

The IS unit need to be aware of its relation to the public, to be successful in the end. A good Relationship should be friendly and mutual beneficial. Conflicts and suspicion are damaging for both parties. The IS unit must express its existence in a way that the public understands and make an effort to attain their interest, acceptance and approval. It is important to convince them that the IS unit operate honest and fair, and acknowledge their demands [24].

The Communication strategy should support the PR of the IS unit.

It should state a consistent, enduring effort to create or shape events to influence the relations of the public to the IS group or an idea. PR should be used consciously to create pictures and circumstances in the mind of the masses. [24]

One authority should control the Communication strategy. [26]

Its goals should be stated, e.g. change an idea in the public mind or change their behaviour.

For a IS unit the long-time Relationship is important. The Communication strategy should therefore underline the importance that all communication maintain the IS units credibility and authority. [26]

It should also state that the PR consequence of an action must be considered before performing that action. It is easier to create circumstances instead of rationalise events. [26]

2. Daily conduct/ pre-communication

The Daily conduct of the personnel in the IS unit should comply with the Communication strategy. This is important to maintain or strengthen credibility and authority and ensure congruent communication.

3. Context of the communication event

To communicate effectively it is important to gather information about the current situation (external Context). [26] This information can be important for how a Message should be conveyed.

The optimal timing of a Message is also important (internal Context) to improve efficiency. [26]

4. Sender

The Sender should appear as credible and with authority, e.g. a leader with prestige. [26] His appearance and behaviour influence this.

If the IS unit has support among group leaders (in the target audience) they can lend their authority. Their support will strengthen the Sender's authority towards the Receiver(s). This support is only possible if it is in these leaders own interests. Therefore, it is important to analyse interests of groups or individuals, which coincide with the Message the IS unit wants to convey. [24]

The IS unit does not necessarily themselves have to be the Sender of the Message they want to convey to the Receiver(s). Based on the situation, the efficiency may improve if they are able to make a 3rd party be the spokesperson on behalf of their Message, without revealing its real origin. This related to the theme white and black PR. It could also be possible to use messages or stories from other sources to strengthen the authority of own Message. [26]

5. Message

A Message should refer to real events when possible since this improve its credibility. Visual images yield greater credibility than spoken or written words and thus improve Message efficiency. It is also recommended Message repetition to strengthen learning, but avoid overdoing it since it then becomes boring. [26]

Well-considered words may be very useful to increase efficiency. Labeling events and people with distinctive phrases or slogans helps to support the PR objectives. The use of carefully considered words might change the opinion of the Receiver(s). The phrases and slogans should possess certain characteristics to achieve this effect [26]:

- They must evoke desired responses which the audience previously possesses." [26, p. 436] By using phrases, that link an event to some knowledge that people possess beforehand, the words can elicit the desired response. Phrases and slogans are used this way to explain news events, so the Receiver(s) interpreted it the "right" way. The PR then produces the desired feelings among the Receiver(s).
- They must be capable of being easily learned.
- Simplicity and repetition is important to facilitate learning, it must be painted in black-and-white to be convincing.
- When the Receiver(s) are familiar with the verbal symbols, they should be used in every proper situation.
- Special terms may be reserved for special occasions to keep their power.

The use of stories have the possibility to arise strong emotions among the Receiver(s) and can therefore be an effective way to pass on a Message.

It is also important to prevent the raising of false hopes, which can be blasted by future events. PR can also be used to diminish the impact of frustration, by anticipate inevitable frustrations and place them in perspective. [26]

If anxiety is used in the Message as a motivator, it must create an optimum anxiety level. Exaggeration may lead the Receiver(s) paralysed while to low anxiety may yield in inactivity, therefore a balance between to two extremes are recommended. [26]

Since people do not like to be told what to do, it can be more efficient to send a Message that are working indirectly. By working through circumstances, the change in behaviour will come to the Receiver as his own idea. [24]

Another method to influence a Receiver's attitude towards an idea is to use the associative process. By creating circumstances to link an idea with a good purpose, a happy event, a respected celebrity and so on, the status of the idea increase. [24]

6. Channels(s)

PR states that the Message must be transmitted through an attention-getting communications medium (Channel), which hits the target audience (Receivers). [26]

7. Receiver(s)

PR must evoke the interest of the Receiver(s). To do this it is important to know and understand the Receiver(s), their attitude and their motivation. When an enterprise understands the public, it will be more able to interpret itself to them. [24]

When communication to unknown Receiver(s) there may not be possible to obtain much information about them. Yet PR theory provide some general assessments about people's behaviour [24]:

- Few people take advantage of the possibility to control their own mind. The masses are an easy target for rumours, advertisement slogans, editorials, news or scientific data and get most of their ideas in this way.
- The general principle that men act upon motives that they unaware of is important. This is believed to be true both in individual and mass psychology. They who seeks to influence men must therefore find the true motivation, and not accept the reason given direct from the actors. Human desires are the true motivation, but a person may be unaware of his own desires.
- The group mind do not have thought, but it has impulses, habit and emotions. Its first impulse is usually to follow the trusted leader due to its herd mentality. This principle operates for instance to cause panic on the stock exchange or creating a best-seller. When the leader is not there, the herd must think on its own. "It does so by means of clichés, pat words or images which stands for a whole group of ideas or experiences" [24, loc. 778]. As an example can the fear of be stamped with the label "communist", frighten the public from perform certain actions or make certain statements.

8. Action/ Result

The efficiency of the communication depends on the Action/ Result that come out of it. To get public support for an idea is an example of such end.

9. Feedback

In mass communication, the Sender may not get any direct Feedback on his communication from the Receiver(s). Feedback may still be available by observing the Action/ Result.

10. Relationship

PR is all about Relationship. It seek to manipulate every factor in order to create a favourable Relationship towards the target Receiver(s). Communication efficiency is the goal and Relationship is acknowledged as a key factor to achieve it.

Finally there must be recognised that clever communication is not able solve every challenge to direct human behaviour. From the experience, it seem that some basic human motivations are not significantly affected by propaganda [26, p. 441]. The examples listed below are modified to fit our context [26]:

- The basic drives of sex and hunger.
- Life threatening situations.
- Work efficiency like industrial production.
- Core values like religious conviction.
- Overt disregard of policies must be met with negative sanctions not words.

4.5 Analysis of Aristotle's rhetoric

Aristotle's rhetoric section from chapter 3 is here analysed and relevant methods and ideas are related to the factors in Metacom.

1. Communication strategy

Aristotle's rhetoric do not specify Communication strategy specifically but the concept of ethos point of the importance of Sender to be credible in the eyes of the Receiver(s).[11] The Communication strategy should therefore state which Messages you in general wants to emit, to whom both in Daily conduct and during communication events. It should also be concern with how maintain and to build an ethos that supports the Messages towards the Receiver(s).

2. Daily conduct/ pre-communication

Daily conduct should be in line with the Communication strategy. This include building and maintaining credibility through demonstration of and improvement of competence, good intention and empathy in Daily conduct.[11]

3. Context of the communication event

Everything is about Context; to be persuasive the communication must be adapted to the Context. [11]

4. Sender

To be credible the Sender needs to hold competence, good intention and empathy. The Sender's credibility will not be the same to every crowd, group or individual. The character of the Sender is almost the most efficient means of persuasion that the Sender possesses. During a speech both verbal and non-verbal will contribute to the Sender's ethos. Aristotle's term ethos can be seen as an important part of the Sender's Relationship towards the Receiver(s). [28]

5. Message

Pathos can be used to influence the emotions of the Receiver(s). This reduce their ability to judge. Knowledge about the Receiver's values and believes are important to use pathos. There are several ways to form a Message, but certain use of language is best fit to create emotional reactions. Storytelling works different from lecture style. The use of exemplifications, illustrations, objects or representation of objects can be used to elicit emotions. [28]

It is difficult to make people change behaviour so it is most efficient to relate the change to something they already believe. This is called to use an anchor. "Anchors can be beliefs, values, attitudes, behaviors, and group norms." [27, p. 33].

Some researcher's think that most human decisions are taken based on unconsciously and emotional processes. If that is so, pathos is a strong persuasive effect.[41]

Logos is concerned with the content, structure, and argumentation, when the Sender appeal to the Receiver(s) through logical reasoning. He will try to convince the Receivers that his arguments represents the truth. The goal is that the Message appear sound to the Receivers. It must not necessarily represent the truth, but appear to be truth for the Receivers. [31]

The composition of the Message is also related to the Channel. During a speech, the Receiver(s) cannot stop or pause to think through the arguments. The Sender must therefore live out complexity even if he is an expert on the topic. The arguments must be presented simple and clear so it is possible for the Receivers to follow the reasoning. [31]

Other Channels that carries written messages have other properties than the spoken and allow for more complex argumentation. [31]

6. Channel(s)

Aristotle's rhetoric are made for a verbal Channel where the Sender stand in front of the Receivers. [11] This Channel make elements like the Sender's voice and visual appearance important. Much of the essence with regard to ethos, pathos and logos remain relevant for other Channels, but may bring in other element to consider. E.g., the voice of the Sender may be irrelevant in a written message, while his spelling may contribute to his ethos.

7. Receiver(s)

The Receiver(s) is the most important part in Aristotle's rhetoric since he/(they)

determines if communication is successful. Therefore, every part of the analysis is done with the Receiver(s) in mind. Knowledge about the Receiver(s) is therefore important. This makes it possible to adapt and optimise every factor in the communication effort to yield maximum efficiency.

8. Action/ Result

The purpose of the communication lead to an Action/ Result. Every optimising effort shall improve the Result.

9. Feedback

Feedback from the Receiver(s) contain valuable information about them. Whether verbal, non-verbal, written, etc. it gives information about the efficiency of the communication. This knowledge can then be used for further optimisation.

10. Relationship

Ethos is the credibility of the Sender towards the Receivers. [11] It can thus be seen as an important part of the Sender's relationship towards the Receivers. Therefore, any optimisation efforts need to keep the Receiver(s) in mind and assess how it will affect the Relationship.

4.6 Analysis of influence through social psychology

The influence through social psychology section from chapter 3, look at some techniques from research in social psychology. As we have seen in the analysis so far, much focus is on knowledge about the Receiver(s). Even if specific knowledge about the Receiver(s) is impossible to obtain in advance of a communication event, there is still possible to influence them. Research referenced by Cialdini in [33], has shown that knowledge about general human traits can significantly improve communication efficiency. From the six categories mentioned in the section, we can relate at least five of them to the Relationship between the Sender and the Receiver. The Sender can influence this Relationship and thus improve communication efficiency.

4.7 Analysis of motivation

The motivation section from chapter 3, look on what factors that trigger peoples Action. Earlier part of the analysis show that the Relationship between the Sender and the Receiver has a huge impact on communication efficiency. The survey from [35, p. 158] list factors that facilitate or block cooperation. Since communication is necessary for cooperation, these factors are assumed just as relevant for communication. Based on this the following factors improve Relationship and thus communication efficiency: openness, honesty, responsibility, trustworthiness, being positive, loyalty, respect and integrity. These factors are also referred to as spiritual needs or core values by Dahlgaard & Dahlgaard in [35] and are represent one of the three categories in "The Trinity Model". On the other hand, the following factors deteriorate Relationships and thus block efficient communication: dishonesty (unreliability), irresponsibility, being negative, disloyalty, arrogance and

egotism.

Dahlgaard & Dahlgaard also describe that an individual has some skills or means to fulfil his mental or psychological needs. These core competencies are subdivided into two main areas namely Emotional Competencies (EC) and Intellectual Competencies (IC). Different humans have unequal balance of EC and IC. This will influence their communication ability. Even it is seldom that a person has 100% EC and 0% IC or vice versa, it is assumed that most people have a preference towards either EC or IC. EC represent interpersonal skills important like emphatic listening, dialogue, etc., prerequisites for successful communication. Humans with little or no EC will have serious trouble in understanding other people. While EC involves sensing and feeling, IC implies reasoning with humans logical and rational capabilities. These skills are typically required in areas like mathematics and technology. EC and IC represent two principal different ways to obtain knowledge – the empirical way and the rationalistic way. [35]

Awareness of the Receiver(s) EC/ IC preferences may improve communication efficiency. The Sender should also be aware of his own preferences. Disregarding these aspects may increase semantic problems in the communication.

Dahlgaard's framework called "The Trinity Model", illustrate three categories of human desires (motivators). Physical or biological (Living) leads to extrinsic motivation, while mental or psychological needs (Learning) and spiritual needs or core values (Loving) cause intrinsic motivation. With extrinsic motivation, he will do the task as a necessary duty to receive his reward (motivators like salary etc.). Contrary in intrinsic motivated situation the person perceive the task itself as 'giving', and identify himself with the task. Then he feels that task itself is a reward and is worth doing for its own sake [35].

Based on this theory a more sustainable motivation is obtained from intrinsic motivation. This insight could be used for communication efficiency by forming Messages and Relationships that appeal to intrinsic motivation.

4.8 Analysis of connection

The connection section from chapter 3 is also about the Relationship between the Sender and the Receiver(s), and affects the effectiveness problem of the communication.

The Sender may not have and prior Relationship with the Receiver(s) and must compete for the Receiver(s)'s attention among many other attention seekers. A prerequisite for communication according to Maxwell is that the Sender connects with the Receiver(s). [38] Connection is vital in any kind of communication. Even when the Sender has a fixed appointment with the Receiver(s), he needs to obtain connection to communicate effectively.

Maxwell claim that the basis for obtaining connection with other people lies in authenticity. In addition to comply with inter-human ethical norms, it is also important due to non-verbal communication. People has an innate ability to recognize genuineness. When the verbal and non-verbal Message are aligned, it sends a strong Message of authenticity. Your attitude speaks louder than your voice. [38]

Maxwell's general principles to connect are then in our communication terminology:

- the Sender recognize the value the Receiver(s)
- the Sender focus on the Receiver(s), not his own ego

- the Sender make the Receivers (s) perceive that he genuinely care for them
- the Sender shows that he can provide something useful for the Receiver(s)
- the Sender is trustworthy

Recognising the Receiver(s) means to focus on them in the communication and find out about their values. Then there is possible to build the Relationship on common values. To bring “a gift” or do a service for others strengthen the Relationship more than words. A gift in this context do not need to be a physical object. A well-prepared story or joke may be such a gift. [38]

Maxwell state that the Sender must be aware that it requires energy to connect to the Receiver(s) and that he must be willing to bring this energy. The larger group of Receivers (audience), the more energy is needed. The Sender must be intentional about connecting and take initiative to connect. A good communicator must be a giver and not a taker of energy. The Sender’s mode reflects his mind-set. A giver is selfless, while the taker is selfish. By bringing the body language, brain and personality into the communication, energy is given to the Receiver(s). Conviction that comes from preparation, passion that comes from conviction and positivity that comes from a believing in other people, all contributes to increased energy [38].

4.9 Analysis of pragmatic human relations

The section on pragmatic human relation from chapter 3 is yet another part with focus on the Relationship between the Sender and the Receiver, and affects the effectiveness problem of the communication.

The basic assumption in this part is that knowledge about human nature increase the ability to improve human relations. When the Relationships improve, the communication efficiency will increase. [39]

To understand other people’s behaviour it is important to see what motivates them according to [39]. [39] One assumption is that most people keep a self-esteem as a mental image denoted ego. What they feel about themselves are related to their perceived strength of this ego. [40] Motivation is often connected to actions, which makes people feel better.

A Sender can contribute to a Receiver’s self-esteem by focus on their best parts. A genuine appreciation of the Receiver will improve the Relationship and improve the efficiency of the communication. On the contrary, will an attack of the Receiver’s self-esteem diminish or block the communication efficiency. The ability to appreciate other people genuinely, rely upon an unselfish behaviour. [39]

4.10 Analysis support with focus layers

Metacom describes the communication process as a collection of factors that influence the effectivity. To analyse single factors in a communication can be useful. On the other hand, there is possible to miss some important aspects. The analysis of several theories of communication above show the necessity of considering a factor’s relationship towards other factors. To highlight some of those aspects there can be useful to analyse the communication with the use of focus layers. The use of Weaves communication problem

levels from [15] as focus layers, makes it easier to spot some important aspects that might get lost when working the each factors isolated. It is also possible to use the focus layers as a tool when considering the different factors of Metacom. E.g. if we lock the focus on the “Effectiveness problem”, we can consider how the different factors of Metacom can influence the Relationship between the Sender and the Receiver(s) and thus the effectiveness of the communication.

Since this thesis is concerned with inter-human communication, the technical equipment used in the signal transmission is not within the scope. Still some technical problems can be assessed by the Sender.

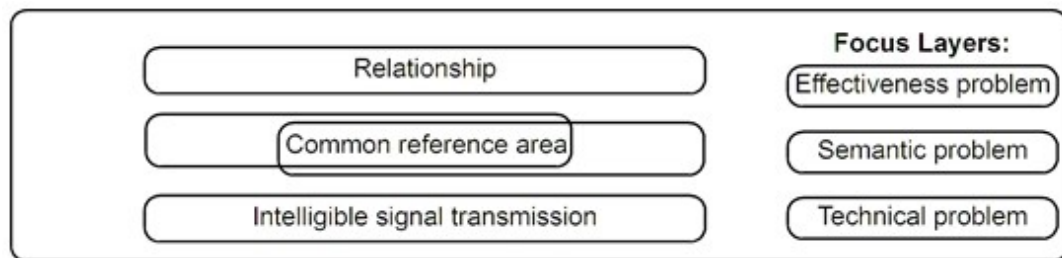

Figure 15: Example of analysis support with focus layers

Focus layers are used to isolate certain aspects of the communication, to ease the analysis. In the real world, these layers are not interdependent and there is no clear-cut borders between them. Still they are useful for capturing important aspect of a specific communication event. Since the focus layers here are used on inter-human communication, they are adapted to this purpose. Therefore, they may not comply with Weavers definitions of communication problem levels in [15].

4.10.1 The technical problem

Even without considering technical details, the Sender should consider certain technical problems concerning his communication event. He can judge if the signal he transmits will be intelligible for the Receiver(s). When the internal Context is determined for the event, he knows how his Message should be delivered to the Receiver(s). An easy example is a performance with a verbal presentation in an auditorium, assisted by a PowerPoint presentation. Technical problems in this Context can be to consider if his voice will be heard by all the Receivers. There might be necessary to use a microphone with loudspeakers to reach everyone. The volume level is of relevance and there might be a need to support hearing-impaired (knowledge about the Receiver(s)).

With the PowerPoint, there is a need to assess if the word are visible for everyone. Improper use of contrast between background and foreground colour can make a words invisible. There is always some difference in the colour representation of your laptop and a projector. Therefore, the slideshow should be tested on the real site to control the quality. There is possible to use contrasting colours to avoid this problem.

Different communication Channels will bring about different technical problems and may remove some aspects. E.g., the clothing of the Sender may send a message to the Receivers during a public speech. Therefore, the Sender should consider his clothing. When the communication happens through a telephone conversation, the Channel hides this aspect of the Sender. His clothing can then not influence the Receiver directly.

To catch the Receiver(s)'s attention is also a part of the technical problem. The Sender must be able to catch the Receiver(s)'s attention in order to convey the Message to him. No communication is possible before the Sender gets the Receiver's attention on his Message. Communication without attention is wasted. Different communication Channels bring different possibilities to capture the Receiver's attention. When an important Message is distributed through loudspeakers on a train station, they may initiate the Message with the words "Attention please". Then the Receivers are able to focus their attention on the loudspeakers before the real Message appear.

4.10.2 The semantic problem

The semantical problem concerns how the Sender's intention is interpreted by the Receiver, when the Message is delivered without any technical errors. As shown earlier the Sender and the Receiver(s) may have different experiences and knowledge. The part they do not share represents an area that are not fit for efficient communication. A security professional will have experience and knowledge that are not known outside the discipline. If he utilise technical phrases unfamiliar to the Receiver(s) a semantic problem occur and the message will not be decoded correctly. Therefore, he should encode his message with symbols that are within the "common reference area" which he share with the Receiver(s).

Even when the Sender communicate with co-workers in the same discipline and use the "common reference area, there still might be semantical problems. The Receiver(s) can interpret a term different that the Sender and misunderstand the Message. Active use of Feedback possibilities can mitigate this problem. Feedback works best in small groups, since many people avoid speaking in a crowd. If the Receiver continually needs to verify the Messages, it reduces the communication efficiency.

4.10.3 The effectiveness problem

When the focus is on the effectiveness problem, we consider aspects that influence the Action/ Result of the communication. We here assume that the Receiver has interpreted the Message as intended by the Sender. Whether the Receiver act upon it according to the Sender's intention relates to the effectiveness problem.

Many different aspects are related to this problem. The Relationship between the Sender and the Receiver is important. If the Receiver has high regard for the Sender he is more likely to conform to his request. On the other hand, if the Sender has insulted the Receiver in a prior occasion, it is likely that he ignore the request or even work against it.

4.11 Communication success criteria

Communication success criteria in this context are the criteria, that if accomplished, the communication will be considered a success. They are thus connected with the purposes of communication in a specific context. General purposes for communication are discussed in section 3.2. The degree of success is related to the Action/ Result label in Metacom model.

Examples of communication success criteria:

- The Receiver regulate his behaviour as intended by the Sender.
- The Receiver change his attitude as intended by the Sender.
- The Receiver absorbs information as intended by the Sender.
- The Receiver perceives an idea as intended by the Sender.
- A desirable Relationship between the Sender and the Receiver is established, maintained or improved.
- The Senders ethos is strengthen towards the Receiver.

4.11.1 Factors contribution to communication efficiency

The factors discussed section 3 represent those factors that *can* lead to communication success or failure. E.g., a well-formulated Message (factor) may contribute to the Action/Result so the Receiver regulates his behaviour as intended by the Sender. On the other hand, a bad-formulated Message may lead to failure and/or damage the Relationship between the Sender and the Receiver. This example show how a factor can influence the communication positively or negatively. It is important to be aware of the fact that many of the factors must be considered relative to other factors.

Metacom describes ten factors for communication optimisation. All factors in the Metacom model influence communication efficiency (i.e. Communication strategy, Daily conduct/pre-communication, Context of the communication event, Sender, Message, Channels(s), Receiver(s), Feedback, Action/ Result and Relationship). These factors can be further divided into sub factors, to emphasize important aspects. E.g., pathos and logos can be regarded as sub factors of the Message.

The Relationship between the Sender and Receiver(s) is a very important factor. A Relationship can of course also be divided into different sub factors. (E.g. Common reference area, trust, ethos, etc.).

5 The importance of communication in information security

Years of personal professional experience within the field of information security, has shown me that people in general do not appreciate the importance of efficient communication. They may be dedicated to solve the tasks within their area of responsibility but do not recognise how their communication capabilities influence their ability to achieve their goal. This section of the report emphasizes the importance of communication in information security.

Communication constitutes a huge part of every person's life both personal and professional. With reference to, the definition of communication is easy to acknowledge this as a fact. Communication activities conducted frequently deserve our attention since they greatly affect our performance. Even small improvements will yield a big reward.

The following example from another domain can illustrate this. For instance if you are able to reduce the time you spend on getting from your home to your workplace with 5 minutes, you have almost got an extra week spare time within a year.

It is easy to assume that your skills automatically improve when you do things often, due to training and experience. Improvements made by streamlining work processes may lead to better performance but not necessarily the most efficient solution. E.g. if you increase your walking speed and optimise the route between home and office, some minutes might be saved. Seeking a very different approach like the possibility to do the work from home once a week, may give a considerably bigger reward.

Corresponding effects are available with optimised information security communication.

Even if we communicate often, the different situations are not equally important. An example is a chief information security officer (CISO) that has the opportunity to present his security project proposal on the board meeting within the company. The outcome of this presentation determines if the project is approved. In this case, his communication skills may be vital for the success. Good communication gives 100% reward for information security, while a failure yields 0%.

The point in the introduction above is to highlight the importance of awareness when it comes to communication. Being aware implies that you do not take your own communication skills for granted. Knowledge about theories on communication gives the necessary background to apply your communication appropriately in the work with information security. When you realise the importance of communication you are in the best position to achieve your goals.

5.1 Information security communication strategy

A security professional always performs his work within a context. In his work, he will have an area of responsibility. As an example, a Chief Information Security Officer (CISO) may

have an overall responsible for information security within his company. His primary goal should then be to ensure that the company keep the risk level for information security at an acceptable level. To ensure that his communication effort support this goal, he should form his own Communication strategy. This should be some short statements “the Message”; he wants to communicate to his surroundings. The Communication strategy should also include consideration about how the CISO (in this case) wants to be perceived by the surroundings to appear credible.

He should keep this strategy in mind always. His Daily conduct must be in congruence with the way he wants to appear, so he builds credibility. Likewise, he must seek to apply elements from the strategy in every communication situations. The purpose is to ensure that all his communication is in correspondence with the strategy and thus the primary goal. The Communication strategy must be adapted to the actual situation and should contain some major Messages, that the security professional think will support his primary and long-term goal.

Below is a simple example that contains a general part aimed at anybody and an additional part for the management within the company. There is also a part to promote the credibility of the CISO. The CISO should create this part to take conscious responsibility for how he wants to be perceived by the surroundings. His daily conduct must be in accordance to this. The example is not a thoroughly prepared Communication strategy, but is meant to illustrate some of the points.

General messages

- The company’s success are dependent on proper information security.
- The company employ comprehensive and strong security measures to ensure information security.
- Every employee is responsible to report threats to information security.
- Violations to information security may lead to disciplinary penalty or prosecution.

Management messages

- Proper information security rely on an organisation culture that supports it.
- Managers on all levels contribute to form this organisation culture.
- Current risk level and major challenges for the company.

Credibility messages

- CISO is professional competent.
- CISO is working to ensure a necessary level of security for the company.
- CISO is authentic, trustworthy.
- CISO has integrity and behave in accordance to his own policies.
- CISO is helpful and care about his workmates.
- CISO is unselfish.

All communication effort that the security professional undertake should build up under his Communication strategy. Even when the communication has a very different objective, there will always be opportunities to include elements that supports the Communication strategy and thus the primary goal. His daily conduct always communicates something to

the surroundings about his credibility. When his conduct is in-line with the Communication strategy, it will increase his communication efficiency.

5.2 Communication – a tool to make an impact

People communicate for various reasons. Since communication is an integrated part of normal human lives, they may not reflected upon the purpose of a conversation. This study aims to leverage efficiency with optimised information security communication. In this context, it is necessary to reflect upon the purpose of our communication. To optimise anything, it is necessary to have a clear picture of the goal. If you are going on a trip without any idea about your destination, it is difficult to choose the direction. The Communication strategy shall help the security professional to communicate in accordance with his long-term goals.

The purpose of communication may vary according to the situation. It must be assessed before any optimisation measures could be initiated.

It is also important to be aware of unintentional communication. Even when you do not intend to communicate anything, you are communicating. Unawareness of this may work against your goals. The Daily conduct/ pre-communication factor in Metacom reflects this issue. For instance as a part of a security training lecture for the employees, you may advocate a clean desk policy. Then the goal of your communication is to influence their behaviour so that they keep their desk clean. If the employees can observe that your desk is a mess, then you have an unintentional communication that counteracts your security lecture. The simple communication model below show the principle where the security professional (Sender) shall communicate something (a Message) to somebody (Receiver). Often, the real communication will go in both directions. Regardless of this, we may want from a security perspective, the Receiver to perceive a certain Message.

Any communication event is an opportunity to make an impact!

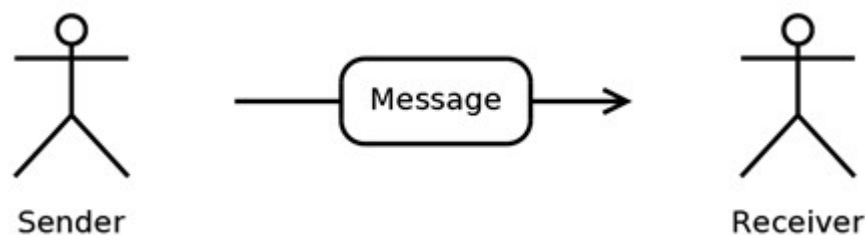

Figure 16: Simple communication model

Therefore, we keep the simple communication model in mind. Our intention is to pass over a Message that strengthen security in every communication event. This means that our Message must convey the information that we want pass on to the Receiver. The Receiver must understand the Message in the way we intended. The because of this communication event, we want obtain some Action/ Result with the Receiver. This could be that the

Message brought some new knowledge to the Receiver. Further that this new knowledge changed his attitude and made him act differently as a consequence.

A simple example illustrates a way we use communication to improve information security. The simple communication model above can be a visual guide in this example where the information security professional is the Sender and an IT user is the Receiver. The company's information system has been infected several time from the IT users' desktop computer. Investigation of the incidents show that the malware are introduced through the USB-port on this machine from the IT users' private USB-stick. The security policy state that private USB-sticks are not allowed on the company's computer system.

Communication can be the tool to handle this situation

The Message to the user is this: We inform that his use of private USB-stick has infected the computer system several times. We also tell him that such use of private USB-stick are a huge threat to the company's computer system. Therefore, this is prohibited according to the security policy. We warn the IT user that further violation of the security policy will result in liability for damages.

The communication is successful if bring about this:

Increased knowledge: The user now know that the use of private USB-stick are prohibited, that such use can make damage and that he can be made responsible.

Changed attitude: He now understands and accepts why it is prohibited.

Changed behaviour: He never use his private USB-stick on the company's computer again.

In addition to use communication as a tool to change behaviour, the security professional also, use it to transfer information from one person to another. As earlier mentioned Janice Light suggested in [8] two other purposes for human communication namely to establish and maintain Relationships with others and to conform to the social conventions of politeness. These purposes may not appear as obvious for an information security professional but a closer inquiry will enlighten their importance.

5.3 Communication of ideas

The trigger for a communication event will often be that the Sender (security professional) gets an idea that he want to transfer to the Receiver(s). This idea could be a mental image in his mind. The Sender's intention in the example below is to make the Receiver comply with his idea, that the USB memory stick should not be used for the TOP SECRET information.

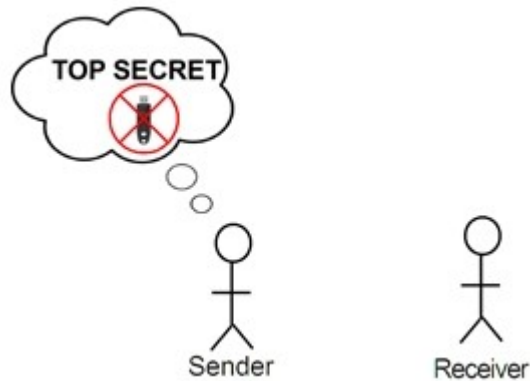

Figure 17: The Sender has a mental image (an idea)

His challenge will then be to convey this idea into a Message that he can pass on to the Receiver.

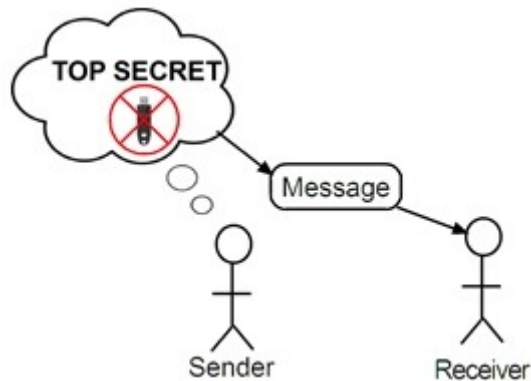

Figure 18: The Receiver has received the Message

When the Receiver has received the Message, he will form his own mental image.

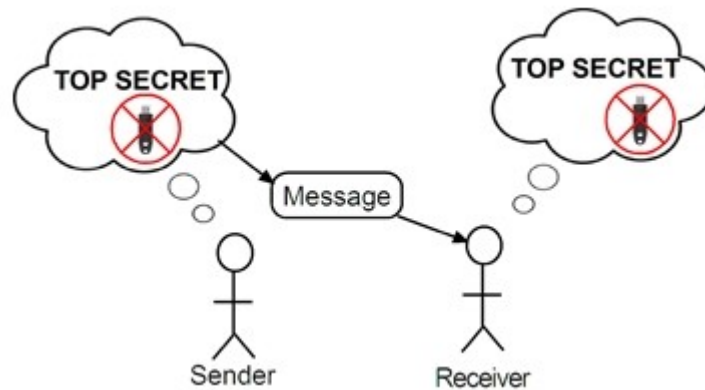

Figure 19: The Receiver has the same mental image as the Sender

In the figure above, the Sender has managed to make a clear Message that is comprehensive for the Receiver. The Receiver has thus been able to make a mental image from the Message that is identical to image hold by the Sender. From this it can seem like the communication is successful, but that is not necessarily true. Even if the Receiver understands the Sender's intention 100%, he may not act accordingly.

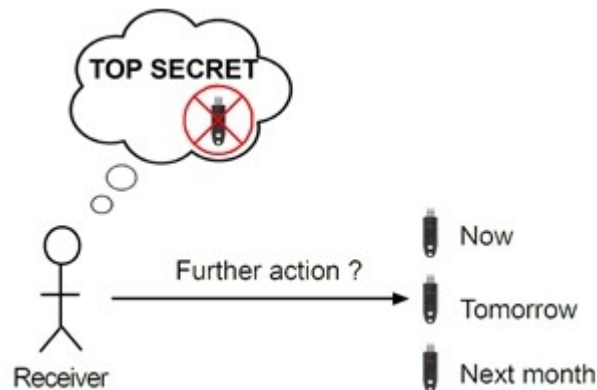

Figure 20: The Receiver's further action determine if the communication has been successful

The Sender's intention was to make the Receiver comply with his idea that the USB memory stick should not be used for the TOP SECRET information. He needed to persuade the Receiver to act in accordance with his idea. The Receiver's further action will determine if he succeeded. He may not be able to verify how the Receiver will handle this in the future and can therefore not be sure if his communication was successful. The success rate may not be all-or-nothing. The Receiver may comply for a while and fall back to his old unwanted habit later. Then it could be necessary to repeat the communication effort later.

This simple example shows that the communication is not only about the transmission of an idea from the Sender to the Receiver. Persuasion of the Receiver is important.

5.4 Communication in information security

Security professionals will have different forms of communication partners and communication subjects. Their area of responsibility and organisational issues will influence their communication requirements. In some companies, the security professional is the only subject matter expert while in other companies he may be a part of a larger security unit. The role of the company and its security unit may also vary. Some companies have a security officer or security unit to handle its internal security issues, while others deliver security services to external parties. Dimitrios Papadopoulos describes roles, interfaces and processes in the information security scene in [42]. His analysis verifies the claim that a CISO must cooperate with many different actors within his company to perform his work. Cooperation requires that CISO communicates with actors like: Executive management, Human resource unit, Procurement unit, Business Services Unit, Facility Management, IT unit, Senior Managers etc. [42] Papadopoulos also describes different CISO area of responsibility that are the purpose for such communication. Some of these areas are Risk management, Security policy management, Organising information security, Asset management, Human resources security, Physical and environmental security, Communication and operations management, Access control, Information systems acquisition and Information security incident management. [42]

Since communication is an integrated part in almost every part of the work with information security, it is not possible to do a complete review of all possible categories. It is also unlikely that this would be an effective way to optimise information security communication. Instead, this study will investigate some different types of communication situations in order to get insight into the most important aspects. First, we will identify some different communication use cases relevant within the field of information security, to get an overview. This dataset will be generalised into some different types of communication situations.

The figure below illustrate communication to and from a Computer security incident response team (CSIRT). This is just one example of a security unit with its accompanying communication partners, but it is useful visualisation. First, it is useful to separate between different types of communication partners. Our ability to communicate will vary dependant of several factor.



Figure 21: CSIRT communication with outside parties from [43]

Some examples of communication partners could be:

- Security professional to every employee within the company
- Security professional to information system users
- Security professional to multidisciplinary project group
- Security professional to manager
- Security professional to other security professionals within the company
- Security professional to other security professionals in other companies
- Security professional to customers
- Security professional to law enforcement agencies
- Security professional to media
- Security professional to threat actors
- Security professional to students
- Security professional to a jury
- Security professional to a IT specialist

A security professional may want to communicate certain issues to this variety of Receivers but he do not always initiate a communication event. An incoming request concerning security issues may address the security professional.

In either case, each communication is an opportunity to improve information security.

A thought-through Communication strategy is important to be able to make the most out of each situation. This study focus on the security professional's intention on improving information security, regardless of which event that trigged the communication.

6 Analysis of communication behaviour and improvement

6.1 Communication use cases

This section will illustrate some communication situations that are relevant for security professionals. The use cases will include a description of the purpose of each specific communication case. This includes information about who is communicating to whom, how it is done and what the information security professional wants to achieve. There will also be a description of the Receiver(s). The Receiver(s) in a use case have certain characteristics and form different target groups.

It is not possible nor desirable to list every communication use case a security professional need to perform through his work. There will be a coarse description of the properties, which will not fit every situation. As an example use case, the information security competence among all information system users is described to be low. This is assumed true for the majority of users, but not for every one of them. Still the use cases will provide useful insight into information security communication. The most important aspect is to provide data for further analysis. The analysis shall give an insight into the variable characteristics of different Receiver(s). From this data there will be selected a small set of unequal target groups that will show why communication needs to be adapted accordingly. These dissimilar target groups are used further in the work for improved efficiency. The use cases are created based on professional experience and information on CISO communication partners described by Papadopoulos in [42] and CSIRT communication partners described by NIST in [43].

6.1.1 Use case descriptions

UC1 - Security professional to every employee/ to information system users

Purpose:

- Raise awareness of relevant security issues that are important for the company.
- Influence attitude towards these security issues.
- Influence behaviour so the employees act in ways that improves security. The goal is that the users are aware of important security issues and act according to the company's security policy.

Communication characteristics:

- One to many communications (a huge group). The goal is to make the greatest possible impact on the majority.
- Communication to a heterogeneous group of Receivers. Only a small part of the

Receivers may be familiar with security issues.

- The Receivers normally focus their attention on other issues than security. Since they have different roles within the company, their focus on different issues. Knowledge about their main concern may be scattered and difficult to obtain.
- The security Message competes with a waste amount of not related issues.
- Security lingo is unknown among most of the Receivers.
- Low technical knowledge must be expected.
- Security requirements hamper their main work effort.
- The Receivers are not subordinate to the security professional.
- The interest for security issues may be absent or week.
- Communication frequency low.

UC2 - Security professional to manager

Purpose:

- Raise awareness of relevant security issues that are important for the company.
- Influence attitude towards these security issues.
- Influence behaviour so the manager act in a way that improves security. Management support is crucial to achieve good security. It gives authority to the work and makes it easier to obtain attention from the other employees. It can lead to an increase in the resources available for security improvements. The benefit may be increase in security personnel or investment in security countermeasures.

Communication characteristics:

- One to one (or a few individuals) communication. The goal is to make the greatest possible impact on an individual person (Receiver).
- Communication to a very specific Receiver. The Receiver may not be familiar with security issues.
- The Receiver normally focus his attention on other issues than security. Knowledge about his main concern is possible to obtain.
- Security competes for the same resources as other units in the company.
- Security lingo is unknown to the Receiver.
- Low technical knowledge must be expected.
- Security requirements can hamper the company and thus the production.
- The security professional is subordinate to the manager.
- The interest for security issues is present, if it is clearly linked to the company's goals.
- Communication frequency low.

UC3 - Security professional to multidisciplinary project group

Purpose:

- Raise awareness of relevant security issues that are important for the company.
- Influence attitude towards these security issues.

- Influence behaviour so the members of the project group are willing to accept that an adequate part of the project resources is spent on security.

Communication characteristics:

- One to group (a small set of individuals) communication. The goal is to make the greatest possible impact on the majority of the group or the most dominant persons within the group.
- Communication to a small but heterogeneous group of Receivers, which attend different roles within the project. The Receivers may not be familiar with security issues.
- The Receivers normally focus their attention on other issues than security. Knowledge about their main concern is possible to obtain, since there is a small set of individuals.
- The security professional competes with other subject matter experts to get resources from the project.
- Security lingo is unknown to the Receivers.
- Some of the group may have technical knowledge.
- Security requirements can hamper other project goals.
- The security professional is peer with other subject matter experts within the project.
- Communication frequency medium.

UC4 - Security professional to other security professionals within the company

Purpose:

- Discuss professional challenges.
- Exchange and build knowledge.
- Improve performance.
- Coordinate effort.
- Create common situational awareness.
- Create common strategies.

Communication characteristics:

- One to group (a small set of individuals) communication. The goal is to make the greatest possible impact on the majority of the group or the most dominant persons within the group.
- Communication to a small but homogeneous group of Receivers. The Receivers are familiar with security issues.
- The Receivers normally focus their attention on security.
- The personality of the individuals are known.
- The Receivers knows security lingo.
- The Receivers have technical knowledge.
- The group has a common goal to keep the company secure.
- The individuals are colleagues.

- Communication frequency high.

UC5 - Security professional to other security professionals in other companies

Purpose:

- Discuss professional challenges.
- Exchange and build knowledge.
- Improve performance.
- Coordinate effort.
- Create common situational awareness.
- Create common strategies.

Communication characteristics:

- One to group (a small set of individuals) communication. The goal is to achieve a good and efficient cooperation that serves both parties.
- Communication to a small but homogeneous group of Receivers. The Receivers is familiar with security issues.
- The Receivers normally focus their attention on security.
- The individuals may know about each other's personality.
- The Receivers knows security lingo.
- The Receivers have technical knowledge.
- Both parties has a common goal to increase security but have focus on their own company.
- The individuals are colleagues.
- Efficient communication procedure can be important to handle incident and exchange knowledge.
- Communication frequency high.

UC6 - Security professional to customers

Purpose:

- Raise awareness of relevant security issues that are important for the customer.
- Influence attitude towards these security issues.
- Influence behaviour so the customer are motivated to buy security.

Communication characteristics:

- One to one (or a few individuals) communication. The goal is to make the greatest possible impact on an individual person.
- Communication to a very specific Receiver. The Receiver may not be familiar with security issues.
- The Receiver normally focus his attention on other issues than security. Knowledge about their main concern is possible to obtain.
- Security lingo is unknown to the audience.
- Low technical knowledge must be expected.

- The customer has always right.
- The interest for security issues is present, if it is perceived to be important for the customers' business.
- Communication frequency low.

UC7 - Security professional to law enforcement agencies

Purpose:

- Report an offense to the police

Communication characteristics:

- One to one (or a few individuals) communication. The goal is to make the greatest possible impact on an individual person.
- Communication to a very specific Receiver. The Receiver may not be familiar with information security issues.
- The Receiver handle many different crime reports.
- Knowledge about the Receiver main concern is not likely to obtain.
- Your report competes with many other crime reports.
- Security lingo is unknown to the Receiver.
- Low technical knowledge must be expected.
- Communication frequency low.

UC8 - Security professional to media

Purpose:

- Comment on specific security incidents or general information security issues.

Communication characteristics:

- One to one (or a few individuals) communication.
- Communication to a very specific Receiver. The Receiver may not be familiar with information security issues.
- The Receiver handle many different news reports.
- Knowledge about the Receiver main concern is not likely to obtain.
- Your report competes with many other news reports.
- Security lingo is unknown to the Receiver.
- Low technical knowledge must be expected.
- Communication frequency low.

UC9 - Security professional to threat actors

Purpose:

- Deter threat actors to attack your company.

Communication characteristics:

- Indirect communication. (You will not speak directly to the threat actors, but your security measures may still send a Message to potential offenders).
- The Receiver may not receive any Message or care about it.
- The Receiver has an intention.
- The Receiver has a certain capability to achieve his goal.
- The Receiver may determine his action based on a risk assessment.
- The Receiver can have from low to high information security knowledge.
- Communication frequency always (every security measure or lack of such sends a Message).

UC10 - Security professional to students

Purpose:

- Build knowledge.

Communication characteristics:

- One to group (a small set of individuals) communication. The goal is to make the greatest possible impact on the majority of the group.
- Communication to a small but homogeneous group of Receivers. The Receivers is familiar with security issues.
- The Receivers normally focus their attention on security.
- The personality of the individuals are generally not known.
- The Receivers knows security lingo.
- The Receivers have technical knowledge.
- The group has a common goal to increase knowledge.
- The security professional has authority over the students through professional experience and grading.
- Communication frequency high

UC11 - Security professional to a jury

Purpose:

- Provide expert witness testimony.

Communication characteristics:

- One to group communication.
- The Receivers are not familiar with information security issues.
- The Receivers consists of very different people
- Knowledge about the audience personality is not likely to obtain.
- Your testimony may be challenged by lawyers.
- Security lingo is unknown to the Receivers.
- Low technical knowledge must be expected.
- Communication frequency low.

UC12 - Security professional to an IT specialist

Purpose:

- Raise awareness of relevant security issues that are important for the company.
- Influence attitude towards these security issues.
- Influence behaviour so the IT specialist maintains system security measures and handles IT security incidents properly.

Communication characteristics:

- One to one (or a few individuals) communication. The goal is to make the greatest possible impact on an individual person.
- Communication to a very specific Receiver. The Receiver is aware of some security issues, but these are not his main concern.
- The Receiver normally focus his attention on other issues than security. Knowledge about his main concern is possible to obtain.
- The personality of the individuals might be known.
- The Receiver knows some security lingo.
- The Receiver have technical knowledge.
- Communication frequency low/ medium.

6.1.2 Analysis of properties for the use cases

By analysing, the different use cases for the information security professional there can be made some general observations. To make the picture clearly set out, the scale of variation is coarse (e.g. as a scale with low, medium or high as possible alternatives).

Group form: Receivers group form could be:

- Individuals
- Groups
- Crowd

The terms group and crowd is here used in this way. Group is used for small number of individuals that are connected by some properties. E.g., that they shall perform a common task (project team) or attend some event for a common purpose (students). Crowd is used for a greater number of individuals than a group where the individuals do not necessarily a share common purpose.

Individual variation: Receiver groups or crowds could be:

- Homogenous
- Heterogeneous

Sender Power: The power (authority) the security professional holds towards the Receivers could be:

- Low/None
- Medium
- High

Com. Frequency: The frequency of communication events between the security professional and the Receivers could be:

- Low/None
- Medium
- High

Motivation: Motivation for information security communication among the Receivers could be:

- Low/None
- Medium
- High

IS competence: Information security competence of the Receivers could be:

- Low/None
- Medium
- High

Lingo competence: Information security lingo competence of the Receivers could be:

- Low/None
- Medium
- High

Technical competence: Technical competence among the Receivers could be:

- Low/None
- Medium
- High

Familiarity: The security professional knowledge of the personality or the focus of the individuals in the Receivers could be:

- Low/None
- Medium
- High

	Group form	Individual variation	Sender Power	Comm. Frequency	Motivation	IS competence	Lingo competence	Technical competence	Familiarity
UC1	C	He	Low	Low	Low	Low	Low	Low	Low
UC2	I	Ho	Low	Low	Med	Low	Med	Low	Med
UC3	G	He	Low	Med	Low	Low	Low	Low	Med
UC4	I	Ho	Med	High	High	High	High	High	High
UC5	G	Ho	Low	High	High	High	High	High	Med
UC6	I	Ho	Low	Low	Med	Low	Low	Low	Med
UC7	I	Ho	Low	Low	Low	Low	Low	Low	Low
UC8	I	Ho	Low	Low	Med	Low	Low	Low	Low
UC9	C	He	Low	High	L-H	L-H	L-H	L-H	Low
UC10	G	Ho	High	High	High	High	High	High	Low
UC11	G	He	Low	Low	Low	Low	Low	Low	Low
UC12	I	Ho	Low	Med	Med	Med	Med	High	Med

Table 3: Summary of the use cases

Table symbol explanations:

UC1 ... UCn: Use Case 1 ... Use Case n

L-H: Low to High

IS: Information security

Group form: (I)ndividual, (G)roup, (C)rowd.

Individual variation: (He)terogeneous, (Ho)mogenous

The description of communication characteristics for each use case is evaluated into a coarse scale. Since each communication situation is unique, with different kind of people, the evaluation will not be precise. E.g. might some of the users in UC1 have high IS competence and a student from UC8 might have low motivation. The main thing is to notice some aspects of the communication performed by a security professional:

- Group form: He must address individuals, groups or crowd of people.
- Individual variation: The group or crowd might consist of a relative heterogeneous or homogenous set of individuals.
- Sender power: The security professional holds rarely power towards the Receivers.
- Communication frequency: Some type of use cases happen often while others have low frequency.
- Motivation: Some of the Receivers have a high motivation to participate in a successful communication while other might initially have low motivation to comprehend the Message.
- IS competence: The Receivers competence within the field of information security varies greatly.

- Lingo competence (IS jargon): Varies much the same, as IS competence. However, some people likes to pick up and use lingo, even if they do not understand the full meaning of the jargon. This can lead to bad communication since you are likely to assume that you meet a peer, when someone use lingo.
- Technical competence: Technical competence is necessary to achieve high IS competence. The opposite is not the case. IT personnel might have high technical expertise and medium or low IS competence.
- Familiarity: This parameter describes whether the security professional has knowledge about the Receivers. At the same time, it indicates if it is likely that he can obtain such knowledge.

6.1.3 Assessment of communication challenges

With the differences listed above there is obvious that a security professional must adapt his communication to optimise efficiency. It is not possible to achieve a good result, if the same form of communication is used in any situation. Two very different use cases illustrates this.

If you as a security professional and manager of a security team communicates with a subordinate, you will generally have the following situation. Then you have a one to one communication, with a Receiver that is motivated for information security. He has knowledge about information security, lingo and technical issues. You also have authority towards this colleague and probably know about his personality and preferences. In this situation, it is possible with successful and efficient communication on advanced issues. You can use specialised terms and lingo unimpeded. Since you both have the same goal, the Receiver is motivated to understand and act upon the Message. Your authority as a leader also strengthen the motivation of the Receiver. There is easy to get Feedback to verify that the Message is received correctly. A healthy Relationship is a necessity for this to work well.

In the other case, you shall communicate to all employees in a general security briefing. Here you have a one to many communications, with Receivers that most likely are unconcerned with information security. They are ignorant of information security, lingo and technical issues. You have no direct authority towards this group and do not know about their personality and preferences. Even if you have these Receivers in an auditorium for a given time, you do not necessarily get their attention. You do not have the authority towards the crowd and the subject does not motivate them automatically. Without their attention, no Message will be received. If you still are able to get their attention, you have to speak in a way that holds their interest. The Message must be encoded in a way that is reachable for the Receivers. In case, you use the same lingo as you normally do among your information security colleagues, no one will understand the Message. It is necessary to use words and symbols that are familiar to the Receivers. Even when you manage to transmit a Message that they understand, they may not act upon it. Without any authority, you cannot enforce this.

These two cases proves that an information security professional must adapt his communication to the situation in order to increase the efficiency.

There is a truism that a security professional cannot be ignorant about his communication. A communication of ideas that will be admired by fellow researchers might be a total failure when he speaks to his manager to raise funding. A motivation speech about the company's security policy may be effective among the IS colleagues, while the same speech will be ignored by the majority of IT users.

A security professional must understand that his communication is maybe his most important tool in his work. By being aware of this and learn how to adapt the communication, he will may greatly increase the efficiency of his work.

6.1.4 Target groups (Receivers)

Based on the analysis of the use cases some dissimilar target groups are defined in this section. These target groups represent different Receiver(s) with different properties. The intention is to use these different target groups as objects in the further investigation of communication optimisation. Even if each Receiver(s) is unique, different groups share some properties. Therefore, a small set of target groups can represent the majority of Receiver groups. A small number that capture the main differences among the Receiver(s), can then be assessed for optimisation. The purpose is to use realistic scenarios when optimisation issues are evaluated. Each scenario consists of the security professional (Sender) and a target group (Receiver(s)). There is assumed that some communication optimisation techniques are applicable in any scenario while other are more relevant for a specific scenario.

To reflect some important variations in such communication, some target groups are created from the table of use cases. The following parameters seem to be vital:

- Is the target group an individual, a group or a crowd?
The size and variation of the Receiver(s) is an important property of a target group. As the number of individuals and variation increase, the number of common factors among them decrease. This fact will therefore influence the ability to reach these people with a Message.
- Do the target group possess IS competence?
This factor is very important to determine what kind of information that could be promoted through the communication. As the summary of use cases indicates this property usually, correspond with lingo, technical competence and motivation.

From these major parameters, it is possible to form the following group constellations:

Group1: Individual with IS competence.

Group2: Group with IS competence.

Group3: Crowd with IS competence.

Group4: Individual without IS competence.

Group5: Group without IS competence.

Group6: Crowd without IS competence.

Looking back on the use cases there can be chosen some scenarios that gives a good variation. Communication between partners that share IS competence is assumed to be

better understood, than communication between a security professional and a person outside this field. Consequently, the majority of the selected target groups focus on communication outside the field.

The selected target groups are therefore:

The manager: Individual without IS competence.

The project group: Group without IS competence.

The user crowd: Crowd without IS competence.

The professionals: Individuals or group with IS competence.

The further study will use Metacom to analyse the use cases with the selected target groups.

6.2 Analysis of use cases with selected target groups

The reason for focus on target groups is that they represents groups of different Receivers, and they are the key to efficient communication. Their response determine whether communication has occurred, since they control the Action/ Result.

Further analysis are done based on use cases with the selected target groups (Receiver(s)):

- UC1 - Security professional to every employee/ to information system users (Crowd without IS competence)
- UC2 - Security professional to manager (Individual without IS competence)
- UC3 - Security professional to multidisciplinary project group (Group without IS competence)
- UC4 - Security professional to other security professionals within the company (Individuals or group with IS competence)

The purpose of this analysis it to illustrate how the differences in target groups (Receivers) and Message content requires different optimisations to be effective. The analysis will not go into detail concerning optimisation techniques; the intention is to establish an insight into why various use cases must be treated differently by showing how they differ.

6.2.1 Analysis method and specification of communication purposes

Metacom is used an initial tool to analyse factors related to the communication events. Each factor are discussed in the relation to the different use cases. It is important to be aware the fact that constructed use cases like this, assume some business context. This means that the analysis made here must be seen as an example, which highlight important issues. In a real world scenario, the analysis must be related to a specific context. E.g. in a huge company only a small part of the employees may know the security professional, while everyone knows him in a small company.

The purpose descriptions (purpose of communication) in UC1-4 are not very precise. In general, they state that the purpose is to raise the Receiver(s) awareness (knowledge), change their attitude and change their behaviour towards certain security issues. At the same time, there may be huge differences in the importance. To make them more useable

for the analysis, some concrete purposes are specified below.

UC1 (Receivers: information system users), purpose: to influence them to never open an email attachment from an unknown source.

UC2 (Receiver: manager), purpose: to convince him to spend €100.000 on a new intrusion detection system.

UC3 (Receiver: multidisciplinary project group), purpose: to negotiate a solution where the project is funding €20.000 for security training.

UC4 (Receiver: other security professionals), purpose: to get acceptance for a more effective information exchange between the actors in the incident handling process.

The two first factors in Metacom are general and therefore not directly a part of any use case. Still they may have considerable impact on the communication efficiency.

6.2.2 Analysis of use cases with Metacom

1. Communication strategy

The Communication strategy is a long-term tool for improved communication efficiency. By defining key messages to key Receiver(s), the security professional can use every opportunity to influence his surroundings towards his goal. This may mould the Receiver(s) attitude towards the goal, even when it is not the subject under discussion. Consequently, it may be easier to get their support at a later point. As described in section 5.1 some of the strategy may be adapted to certain groups (e.g. management messages), to reinforce certain aspects. The strategy should also reflect how information security unit which to be perceived by the surroundings, to strengthen their credibility.

With regard to our target groups in UC1-4, the Communication strategy is most relevant for UC1-3. It is reasonable to assume that the security professional within UC4 share the same Communication strategy. On the other hand, it is possible for an individual to keep his own personal Communication strategy, to communicate certain issues about himself and thus strengthen his own credibility.

The efficiency of having a Communication strategy depends on how often the security professional interacts with different target groups. Each time “a Message” reach a Receiver, it will contribute towards the goal. The Messages from the Communication strategy can reach the Receivers in different ways. Verbal interaction is just one Channel, there are many other possible Channels like images, posters, emails, articles, security briefings etc.

2. Daily conduct/ pre-communication

Everyone communicate always. Our Daily conduct and appearance send Messages to our surroundings, whether or not we are aware of it. Future Receiver(s) will make up an impression of the security professional based on this and it then influence their Relationship with the Sender. In a later communication Context, the Relationship between the Sender and the Receiver(s) may be vital for success or failure.

For UC1, this factor may not be vital. Since information system users in a company can be a huge crowd of people distributed in different areas, they may not experience the Daily conduct of the security professional. Then the Pre-communication will be minor.

In UC2, the manager is the Receiver. Dependent on the company size it is likely that he have observed some of the conduct of the security professional and has a preconceived impression of him (Relationship).

In UC3, the multidisciplinary project group are the Receivers. This is a group of several people and it is likely that they also has a preconceived impression of the security professional (Relationship).

In UC4, professional workmates are the Receivers. Since they work together every day, they will have a clear impression of the security professional (Relationship).

The different Receivers have established various impressions (Relationship) of the security professional based on his Daily conduct and their experience with it. They who have a seen him often will usually be more confident with their own impression, than others who have just met him once. Still the first impression is important, since it can be hard to change. Their preconceived impression will strongly influence his credibility towards them.

As we can see from the use cases, the Daily conduct of the security professional affect the Receivers that can observe it and influence their Relationship. Their impression of him may contain different elements like skills, competence, intention, attitude, empathy, authority, integrity, openness, honesty, responsibility, trustworthiness, being positive, loyalty, respect, genuineness etc.

Later when the security professional act as a Sender in a communication, the Receivers prior impression off him will significantly affect the efficiency.

In UC2, the manager may have a prior opinion about his capability and his trustworthiness. Equivalent will the various people in UC3 and UC4 have their own opinion, but it is not necessarily identical. When the security professional communication is dependent of one Receiver (like UC2), the established impression is vital. If the Receiver has a negative impression of the Sender, the efficiency will deteriorate. When the communication is directed towards a group (like UC3 and UC4), the impression of the most influential individuals in the groups will be most important to optimise the communication. [24]

To sum up a security professional should be conscious about his Daily conduct as a very important part of communication optimisation. By genuinely and consistent demonstrate professional skills, good intention, empathy and trustworthiness, he will build good Relationships as the foundation for efficient communication. Aristotle describe the importance of the speakers credibility in [11], and Daily conduct is long-term building of credibility. It is important to remark that the Receivers impression of the security professional is not only made up from passive observation. Every interaction between them contributes to their Relationship. The security professional can therefore make an active effort to improve his Relationships towards people in his surroundings. It is important to be genuine in this endeavour as Maxwell state in [38]. Attempts to gain benefit from false behaviour is unethical and will bring future loss.

3. Context of the communication event

The external Context for our use cases are not defined. In all of the use cases, there may be useful to utilise the external Context to optimise the communication. For UC1

(Receivers: information system users), there can be efficient to link the Message with a similar security incident from the news (external Context) that has led to personal loss. Since most people are concerned about their own assets, they can be motivated to change behaviour when it can protect their own property. For UC2 (Receiver: manager), the link should be made against some external event, that illustrates how a company faces severe consequences due to improper security measures. The timing of a proposal may optimise the communication, if it is raised after a recent event. For UC3 (Receiver: multidisciplinary project group), links to prior support statements from top leaders towards security, may strengthen the support within the group. With UC4 (Receiver: other security professionals), it is reasonable to assume that the external Context could be shortcomings in the current incident handling process.

Internal Context is about the communication event itself and will therefore be different in UC1-UC4 (factor 4-9). Duration is an important aspect to consider. In UC1 (Receivers: information system users), there may be a time slot scheduled for a security briefing. It is possible that the Sender can determine how long his briefing should be within certain limits. With UC2 (Receiver: manager), one can expect a shorter timeframe and less opportunity to influence duration. A project as in UC3 (Receiver: multidisciplinary project group), also works within a time schedule. Participation in regularly project meetings, make it possible to promote security issues on the agenda in several meetings. Then there will be more time available to ensure best possible communication Action/ Result. Collaboration among work mates as in UC4 (Receiver: other security professionals), in an ongoing continuous process and provides many opportunities for communication.

4. Sender

The Receivers must consider the Sender credible and/or an authority, if communication should be efficient. [11] Daily conduct/ pre-communication will influence their Relationship, and thus his credibility towards different Receivers. The Receivers impression of the Sender and their Relationship will have a huge impact on communication efficiency. The Receivers must also believe that the Sender has competence related to the Message he pass on.

In UC1 (Receivers: information system users), the Sender may not be known to the crowd prior to the event. An introduction of the Sender by a well-known leader within the company may strengthen the Senders authority. [24] It will also be important use some time of the event to build credibility towards the Receivers. They need to know why they should listen to his Message. With UC2 (Receiver: manager), the Sender will hopefully have some prior credibility established through Daily conduct. If not so, it will be harder to get the desired Action/ Result from the Message. If the manager on the other hand regard the Sender as unreliable, it would probably be impossible to achieve efficient communication. In such cases, it would be wiser to let another person to front the Message towards the manager. For UC3 (Receiver: multidisciplinary project group), the Sender must at least be credible towards the majority of the Receivers or the most influential of them. In UC4 (Receiver: other security professionals), the Sender has a work mate relationship towards the Receivers. His credibility among his colleagues will make a huge impact on the communication efficiency.

As can be observed from the various use case, the Sender will have different credibility towards the target groups. He must be aware of this fact to adapt the communication accordingly. Possibilities to strengthen his authority should be utilised.

5. Message

The Message shall carry the Senders idea over to the Receivers and create some Action/ Result. In UC1 (Receivers: information system users), the Message intend to influence the behaviour of the Receivers so they never open an email attachment from an unknown source. This Message does not place a heavy burden upon the Receivers, but it must still convince them why this is a good idea. They must be convinced that the proposed idea is beneficial for them. Since the Receivers are a heterogeneous group with many people, the “common reference area” will be smaller. The Message must be formed so it fits within this reference area. In UC2 (Receiver: manager), the Message shall convince the manager to invest €100.000 on a new intrusion detection system. This Message carries a heavier burden than in UC1 and it is directed to just one Receiver. The weight and importance of the idea requires a more thought-through Message. In this case, the ability to optimise the communication may yield a 100% successful Action/ Result. Otherwise, the communication might become a wasted effort with no Action/ Result. Since there is just one Receiver, the Message can be adapted to this person alone. Like in UC1, it must still be in the “common reference area”. In UC3 (Receiver: multidisciplinary project group), the idea is to get a project to fund €20.000 for security training. The burden of this Message depends upon the total budget of the project. The Receivers are heterogeneous group like in UC1, but contains a smaller number of persons. In UC1, the Message ideally should reach every member of the crowd. This might not be necessary, to reach the goal in UC3. There might be enough to convince a few influential members of group, to get acceptance. Knowledge about the project group is necessary, but it is also available if the Sender himself is a part of the group. The Sender can then optimise the Message towards these most influential members. In UC4 (Receiver: other security professionals), the Sender will get his work mates acceptance for an idea about an improvement of the incident handling process. The burden of this Message is not heavy, if he is able to convince them that this is a good idea. Since the Receives are a homogeneous group within the information security discipline, they share a “common reference area” within this field. This allows the Sender to use his expertise to create the Message with technical lingo and explanations. In UC1-UC3, this is not fruitful, since it would fall outside the “common reference area”.

The above discussion concerning the Message show why it is important that it be crafted to fit the situation and Receivers. Messages that are more superficial might be most effective to influence Receivers that are unfamiliar with the discipline of information security. In this context, technical explanations may then disturb the Message. On the other hand, a Message to professional colleagues must be backed up by detailed facts, which builds on common knowledge within the discipline.

6. Channel(s)

The Channel(s) represents the medium that carries the Message from the Sender to the Receivers.

In UC1 (Receivers: information system users), the Message intend to influence the behaviour of the Receivers so they never open an email attachment from an unknown source. This kind of Message is not just connected to one specific communication event. The Message might be delivered through at security briefing where the Channels might be vocal in combination with a visual presentation. Many other Channels are possible like awareness emails, posters, web articles etc. The Sender should consider which Channels that are most efficient to capture the Receivers attention. [26] Several Channels can be utilised in the effort.

In UC2 (Receiver: manager), the Message shall convince the manager to invest €100.000 on a new intrusion detection system. Here the Channel might be predetermined and not possible to be changed by the Sender. If the Manager is distant from the security professional, there might even be hard to obtain a Channel. A formal written letter to the manager might then be a possible way to capture attention to the issue. If successful, this may open another Channel where it is possible to deliver the Message.

In UC3 (Receiver: multidisciplinary project group), the idea is to get a project to fund €20.000 for security training. The possible Channels to carry the Message to the projects is usually not limited only to vocal and visual means through project meetings. The working methods decided for the project may provide several Channels. Formal hearing of project documents opens an important channel to forward the Message through a written response. In other cases, the project group create the project documentation as a joint effort. Then this documentation itself is a powerful Channel. A well-formulated written contribution may then reach the Receivers in a form that is easy to accept.

In UC4 (Receiver: other security professionals), the Sender will get his work mates acceptance for an idea about an improvement of the incident handling process. The most relevant communication channel will depend upon several factors. A group with a solid “common reference area” within their discipline, might communicated effectively through several Channels. The complexity and controversy in the Message should influence the choice of Channel. A simple and uncontroversial Message could be sent through any Channel. When the Message is complex or controversial, Message might be easier to transfer during a physical meeting with vocal and visual Channels.

When selecting Channels, it is important to be aware of certain properties of these Channels. In a face-to-face conversation, it is usually possible to avoid disturbance from competing Channels. When the Message is sent as an email to the Receivers, it is just one message among a lot of others. It is difficult to know if the Receivers have read it thoroughly, just skimmed it or not read it at all. He might also be disturbed while reading it by other colleagues, phone calls, instant messages etc.

7. Receivers

Receivers in UC1 information system users), are described as a crowd without IS competence and with low motivation for the discipline.

Receivers in UC2 (manager), is described as an individual without IS competence and with medium motivation for the discipline.

Receivers in UC3 (multidisciplinary project group), are described as a group without IS competence and with low motivation for the discipline.

Receivers in UC4 (other security professionals), are described as an individuals or a group with IS competence and with high motivation for the discipline.

Common for UC1-3 is the lack of IS competence and low/medium motivation for the discipline. This make up some general knowledge about the Receivers that must be reflected in the Message. They must be convinced about why the Message is important to them in a language they understand. This is not an audience to impress by complex elaboration on technical issues. There will be necessary to highlight different factors to create motivation for the different groups in UC1-3. In UC1, there will be a heterogeneous group of people, which the Sender will not know. Still there can be made some assumption about them as a group. It is likely that they all use computers to manage important issues in their private lives. Attention and motivation can then be built by using, examples related to these interests like e.g., e-bank fraud. In UC2 when the Receiver is an individual, it is possible to obtain more in-depth knowledge about the Receiver. This information can then be used to create a suitable motivation within the Message. For UC3 there is also possible to obtain more knowledge about the Receivers. The motivational part of the Message should focus on the most influential individuals in the group.

In UC4, there is possible to assume that the Receivers have IS competence and a high motivation for the discipline. This knowledge about the Receivers makes it possible to address the issue directly without the need to establish motivation. The Message can then also include lingo, technical terms and more complex argumentation if necessary. It is also reasonable to assume that they will actively engage to make sure they have understood the Message as intended.

8. Action/ Result

Action/ Result denotes the outcome or result of the communication. It determines if communication has taken place and thus the efficiency.

UC1 (Receivers: information system users), the Message intend to influence the behaviour of the Receivers so they never open an email attachment from an unknown source. Whether this communication effort provides Action/ Result can be difficult to measure. It is not likely that it manages to change the behaviour of every user in all future. Still it might change some user behaviour in a way that reduces security incidents within the company.

The Action/ Result will be easier to observe in UC2. Either the manager agrees to invest in a new intrusion detection system or not. Still it might be something between €100.000 and €0. Similar the Action/ Result from UC 3 and UC4 will be visible.

9. Feedback

The Feedback factor indicates the possibility for the Sender to get some response on his Message. This is very important, since it is difficult for the Sender to know how the Receivers perceive the Message. Feedback helps the Sender to learn about his

communication and makes improvements possible.

In UC1 when the Sender address a crowd, the situation make Feedback rare. Few individuals feel comfortable to raise their voice within a crowd, so a few comment may not represent the crowd's perception of the Message. Feedback is more likely in UC2. In UC3, certain member of the group may give Feedback, while other remain silent. Among the colleagues in UC4, the possibilities for Feedback is probably similar to UC3. The size of the groups and the Relationship between the individuals influence the likelihood for a balanced Feedback.

Even if no active Feedback is provided by the Receivers, it may still be possible for the Sender to get Feedback by observing non-verbal cues with the Receivers.

10. Relationship

As can be observed through the discussion of the other factors, the Relationship will influence the communication efficiency. How crucial this factor is varies in the different use cases, but it is always important.

The Relationship between the Sender and the Receivers will also influence the chances of Feedback. Trust in the relationship foster true Feedback, while mistrust lead to false or none Feedback. The creation of the Message influence on the Relationship. When the Sender tries to strengthen his ego by adding needless complexity to the Message, he creates a distance between himself and the Receivers. This harm his Relationship with them and blocks constructive Feedback.

6.2.3 Summary of use case analysis

The analysis of UC1-4 above have shown how the difference in target groups (Receivers) and Message content requires different optimisations to be effective. The variation and optimisation requirements are unequal for the different factors in the Metacom model.

6.3 Properties of information security communication

A security professional depend upon communication as a tool to achieve information security. Through section, 5 and 6 several aspects of information security communication are discussed. Here some of this insight is collected to provide a broad picture of the properties of this communication.

A security professional uses information security communication:

- to deal with a complex discipline.
- to fulfil many different purposes, that can only be obtained through skilful communication.
- to convey information and ideas to the Receiver(s).
- to change the attitude of the Receiver(s).
- to regulate the behaviour of the Receiver(s).

Receiver(s) / audience of this communication is a wide and heterogeneous group:

- They have different educational background.

- They have different competence to towards the topic (from none to high).
- They have different motivation towards the topic (from none to high).
- Even experts may just be familiar within a narrow field of the discipline.

In most of the use cases examined, the security professional do not hold any formal authority towards the Receiver(s). The communication frequency is also low in many cases. Likewise, he do not have a familiar Relationship towards many of the Receiver(s).

7 Tools for optimised information security communication

The most vital point to grasp for an information security professional is to acknowledge that communication is probably his most important work tool. This understanding creates a motivation to learn how the tool can be applied in the best possible way. Every security professional has the opportunity to leverage efficiency with optimised information security communication.

The metaphor tool is here used to denote a technique or theory that can be used to optimise information security communication. A tool can be used to adjust the optimisation factors that are described in the Metacom model. It is important to note that adjustments can lead you towards or away from communication success. Therefore, it is important to use the tools correctly to adjust the optimisation factors in the desired direction. Likewise, the metaphor multi-tool is used to denote a collection of different techniques and theories. As with real world multi-tools, different tools may have overlapped functionality. With several multi-tools in our toolbox, the security professional will be able to leverage efficiency with optimised information security communication.

7.1 General

You are always communicating, even when you are silent. The surroundings interprets both your words and your appearance, even when they are not a part of the conversation. Therefore, you should form a strategy about what you intend to communicate and act accordingly. Your credibility is always connected to your conduct.

Every communication situation is an opportunity to make an impact.

The communication always has a purpose and by being aware of the goal, it is more likely to reach it. To be credible, ensure that your goals are in line with your true feelings. When you “own” the Message, your communication will be congruent [38].

A successful communication always requires some impact on the Receiver. Since the Receiver determines the end, all optimisation effort must keep this in mind [11]. Therefore, the Receiver has always right. If he do not perceive or act upon a Message as intended, the Sender must improve his communication. Every Receiver is unique and may therefore need special adaption of the communication.

Different models can be useful to analyse optimisation possibilities, but can result in an artificial object-to-object perspective on the communication process. It is therefore important to remember that human-to-human communication is subject-to-subject

communication.

Efficient communication between humans rely upon a good Relationship between the parties. A good Relationship should be based on trust and be mutual beneficial according to Maxwell in [38]. Therefore, the security professional should be honest in his communication and provide something useful for the Receiver. This will come natural if the security professional genuinely care for the Receiver. [38]

The Relationship between the Sender and the Receiver(s) is thus a very important factor for communication optimisation. On the other hand, has every communication event the possibility to influence this Relationship in a positive or negative direction. This reciprocal action between Relationship and communication is important to recognise. Relationship forms the basis for efficient communication and communication establishes and modifies Relationship.

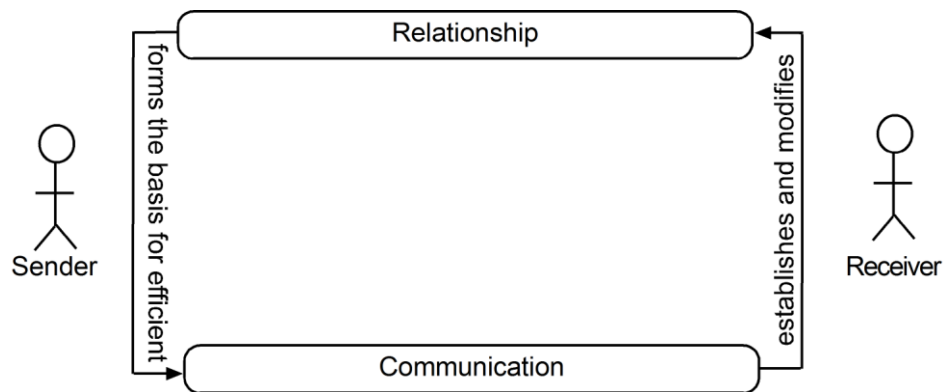

Figure 22: The Relationship and communication interaction

There are several tools available to optimise communication. Initial effort should be based on simplicity. When the security professional master the basics, further optimisations can be made by adding more multi-tools.

7.2 The fast track optimisation

The old wisdom from Aristotle’s rhetoric covers many important aspects of communication optimisation [11]. This theory makes it possible to achieve quick improvements through the concept of ethos, logos and pathos. The communication model and key terms make it easy to remember and apply in real-time scenarios.

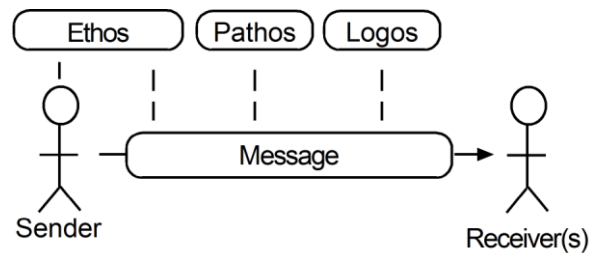

Figure 23: Aristotle’s rhetoric from [11] visualised by Sveen

7.3 Further optimisation tools

This study has showed that a security professional can further optimise his communication by applying different techniques and theories. To aid this effort, a communication model called “Mental model for communication optimisation (Metacom)” is proposed through this thesis (see section 4.3). Metacom is based on different communication models and theories studied in this thesis, and describes 10 factors that are relevant for communication optimisation.

Metacom can be used to analyse communication optimisation in its own right. However, it can also be used to map communication improvements from different theories into a common framework. Examples on how optimisation techniques from different sources can be connected to factors in Metacom is shown in appendix 1.

The description of the other multi-tools refer to factors in Metacom. Metacom support both a strategic and a tactical view of communication optimisation. Strategic perspective supports the long-term effects of the communication while the tactical view consider a specific communication context.

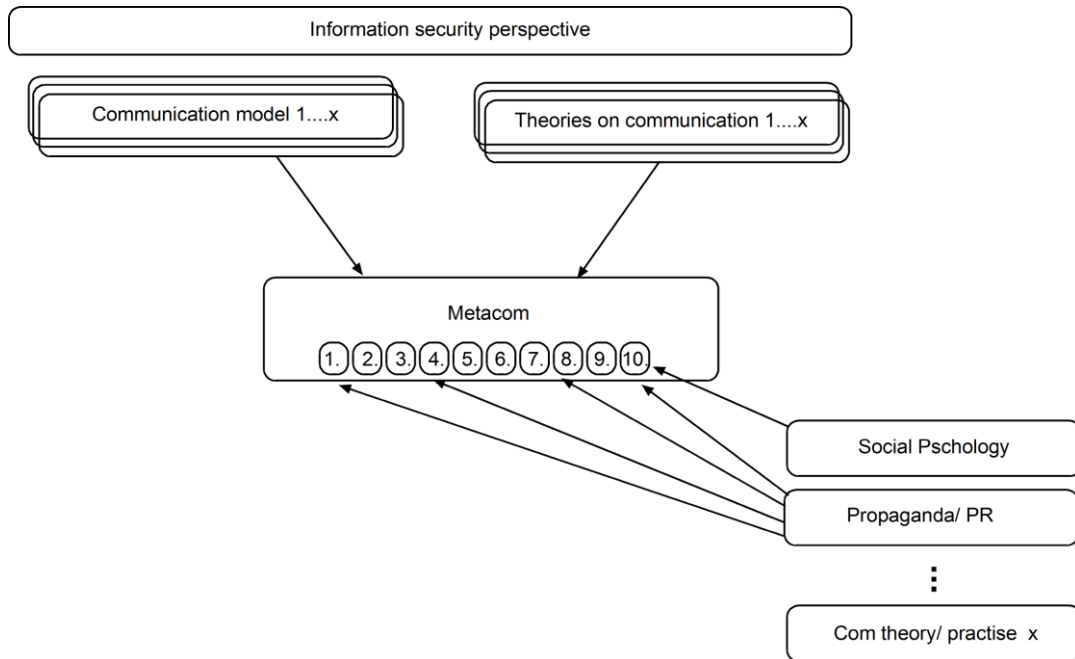

Figure 24: Creation of Metacom and mapping of optimisation factors

The figure above shows how Metacom is made from communication models and theories with 10 factors. The bottom part of the figure shows how different communication theories can be mapped to the optimisation factors in Metacom.

Below is an overview over how different multi-tools for communication optimisation described in this thesis, relates to factors in Metacom. A more detailed description of these multi-tools is provided in section 4.

- **Aristotle's rhetoric (ref. section 4.5):**
The concept of ethos describes ways to improve the Sender factor, while the pathos and logos primarily describes possible improvements of the Message. Every part is considered in relation to the Receiver(s).
- **Public relation (PR) (ref. section 4.4):**
PR contain tools to improve most of the factors in the Metacom model, but cover Communication strategy, Message and Receiver(s) best.
- **Social psychology (ref. section 4.6):**
Social psychology tools are primary used to improve the Relationship factor through general knowledge about the Receiver(s). The focus is on how certain events trigger subconscious human behaviour.
- **Motivation (ref. section 4.7):**
Motivation tools are also used to improve the Relationship factor through general knowledge about human motivation. It also support useful insight about some aspects of the Sender and the Receiver(s).
- **Connection (ref. section 4.8):**
Connection tools are a multi-tool used to improve the Relationship factor through appropriate adjustment of the attitude and behaviour of the Sender.

- **Pragmatic human relations (ref. section 4.9):**
Pragmatic human relations tools are yet another multi-tool used to improve the Relationship factor through general knowledge about the Receiver(s) motivation.
- **Focus layers (ref. section 4.10):**
Weavers focus layers from [15] is a useful multi-tool that can be applied to focus on certain aspects of communication optimisation at a time. E.g., one of the analysis can study how the factors in Metacom can be optimised to overcome the semantical problems in a communication.

7.4 Three key insights

Information security professionals often have a background from technical sciences. They are therefore used to consider relations between objects, where it is often possible to describe cause and effect with mathematical precision. From this perspective it should be possible to convey information as neutral facts.

However, when it comes to inter human communication, it is always subject to subject communication. This implies that it is difficult for a Sender of a Message to be certain on how it is interpreted by the Receiver. The Sender have to encode his idea into a Message that he hope will bring about the desired Action/ Result with the Receiver. Still neither the Sender nor the Receiver exists in a vacuum. The Message will always appear in a larger context that may influence the effect. Therefore it is not sufficient to convey plain facts, there is no neutral information. It is necessary to place the information in the proper perspective to be useful. Failure to do so can also be regarded as disinformation, so a security professional must use his expertise to provide this perspective.

A security unit within a company may have limited time to communicate information security issues to relevant actors. Rare security briefings to a crowd on specific topics, may be insufficient to make necessary impact. By implementing a Communication strategy, there is possible to amplify specific Messages towards the Receivers. This is relevant for Messages that remain important in a long-term perspective. By repeating these Messages coherent through different channels over a longer period, they will amplify the Action/ Result of the communication.

The use cases from this research show that a security professional to a huge part needs to address Receivers (target groups), that have low knowledge and motivation related to information security. Optimised information security communication towards these groups is not to be found within the discipline. Detailed explanations of complex issues within information security will likely decrease communication efficiency. Optimisation efforts must adapt to the Receivers perspective and provide a Message that sounds useful for them.

8 Future work

Human communication is a vast topic area and can be regarded as an own field of research. Yet it has a tremendous impact on other disciplines. The work within this thesis has focused on why human communication is important for information security professionals and how it can be optimised for increased efficiency. It clearly shows that optimisation efforts should be adapted to the context. Within the field of information security, there will be innumerable of different communication situations with various importance. Most of situations must be handled straightforward, without the need for special considerations. Yet there is possible to improve efficiency by complying with some of the general recommendations from this thesis.

Since communication is such an important topic within information security, several issues deserve further investigation. Optimisation techniques promote through this thesis integrates some ideas from fields as social psychology, psychology and communication theory. Since these are areas of research in their own right, an in-depth investigation of them is not a natural part of the information security domain. Still more investigation of applied knowledge from these areas, can be used to further enhance communication within information security. In addition, other areas may yield useful insight like e.g. pedagogics, media science and marketing science. The use of Metacom is proposed as a way to integrate optimisation techniques from different sources.

This thesis indicates that information security professionals to a huge degree needs to communicate with people that lack knowledge and motivation for information security. A research of what kind of information and detail level, which is suitable to convey to this audience, could be useful to increase communication efficiency.

Communication theory and practical applications show that symbols and slogans may be effective to carry Messages to a wide audience. A research on information security communication could develop ideas on how symbols and slogans could be used, to communicate central ideas from information security. Theories from semiotics and linguistics would provide useful input for this work.

Techniques for measurement of communication efficiency is yet another task that are left for further research.

9 Conclusion

Every information security professional is dependent upon communication to fulfil his tasks. Since information security is comprised by technical, organisational, human and legal issues, it requires cooperation between professionals and individuals with very different background and education. The security professional's ability to communicate efficiently with this diverse audience will have a huge impact on the security level.

There seem to be little research literature within the discipline, which discuss quality aspects of human communication on information security. By analysing different communication models, communication theories and literature from different areas of practice and research, we have identified several factors that influence the communication efficiency of a security professional. These factors are visualised in to a model called Metacom, to be used as a tool for communication optimisation.

Communication use cases are used to identify properties of information security communication. The analysis show how different target groups (audiences) have different properties that will affect the communication differently. Use cases with a small subset of selected target groups are used to exemplify how optimised information security communication can be assessed with Metacom. This illustrates why communication optimisation should be adapted based on general characteristics of these target groups.

The proposed Metacom model address both strategic and tactical communication optimisation. It points out how a long-term perspective on communication will amplify the effect, in addition to the efficiency that is obtained through short-term context specific optimisation. The thesis also demonstrates how Metacom can serve as a framework to integrate communication optimisation techniques from different theories and practices. The insights provided show how security professionals can utilise knowledge from other disciplines as tools to enhance their communication performance and thereby strengthen information security.

Bibliography

1. Wikipedia. *Global Internet usage*. 2015 [cited 2015 05-07]; Available from: http://en.wikipedia.org/wiki/Global_Internet_usage.
2. Leedy Paul D.; Ormrod, J.E., *Practical research planning and design*. 8 th edition ed. 2005, Upper Saddle River, New Jersey: Pearson Prentice Hill.
3. Littlejohn, S.W.F., Karen A. , *Theories of Human Communication*. 2010-11-01, Waveland Press, Inc.
4. Hovland, C.I., *Social Communication*. Proceedings of the American Philosophical Society, 1948. **92**(5): p. 371-375.
5. Nilsen, T.R., *On defining communication*. The Speech Teacher, 1957. **6**(1): p. 10-17.
6. *Communication*, in *Online etymology dictionary*. 2016, Douglas Harper.
7. Murphy, J. *What are the main purposes of human communication?* 2014 [cited 2015 07-23]; Available from: <http://www.talkingmats.com/main-purposes-human-communication/>.
8. Light, J., *Interaction involving individuals using augmentative and alternative communication systems: State of the art and future directions*. Augmentative and Alternative Communication, 1988. **4**(2): p. 66-82.
9. Locke, J.L., *Where did all the gossip go? Casual conversation in the Information Age*. American Speech Language Hearing Association, 1998. **40**(3): p. 26-31.
10. Craig, R.T., *Communication Theory as a Field*. Communication Theory, 1999. **9**(2): p. 119-161.
11. Aristotle, *Rhetoric*. 384-322 BCE, The University of Adelaide Library. .
12. Lasswell, H.D., "*The Structure and Function of Communication in Society*," *The Communication of Ideas*, ed. L. Bryson. 1948, New York: Institute for Religious and Social Studies, Jewish Theological Seminary of America.
13. Shannon, C.E., *A mathematical theory of communication*. SIGMOBILE Mob. Comput. Commun. Rev., 2001. **5**(1): p. 3-55.
14. Shannon, C.F.a.W.W., *The Mathematical Theory of Communication*. 1964, Urbana, Ill: The University of Illinois Press.
15. Weaver, W., *Recent Contributions to The Mathematical Theory of Communication*. 1949.
16. Schramm, W., "*How Communication Works*," *The Process and Effects of Mass Communication*, ed. W. Schramm. 1961, Urbana, Ill: The University of Illinois Press.
17. Rahmanjmc. *OSGOOD- SCHRAMM MODEL OF COMMUNICATION*. 2015; Available from: <https://rahmanjmc.wordpress.com/2015/02/09/osgood-schramm-model-of-communication/>.

18. Riley. Jr., J.W., Riley, Matilda White *"Mass Communication and the Social System."* *Sociology Today, Volume II*, ed. L.B.a.L.D.C. Robert K. Merton, Jr. 1965, New York: Harper and Row.
19. *Riley & Riley Model of Communication*. 2015 [cited 2015 07-27]; Available from: <http://communicationtheory.org/riley-riley-model-of-communication/>.
20. Luft, J., *The Johari Window: A Graphic Model of Awareness in Interpersonal Relations*. NTL Institute: Human Relations Training News, 1961. 5(1).
21. Wallace, H.R., Cliff, *Written and Interpersonal Communication: Methods for Law Enforcement, Fourth Edition*. 2009: Prentice Hall.
22. Rawal, P., *AIDA Marketing Communication Model: Stimulating a purchase decision in the minds of the consumers through a linear progression of steps*. IRC'S INTERNATIONAL JOURNAL OF MULTIDISCIPLINARY RESEARCH IN SOCIAL & MANAGEMENT SCIENCES 2013. 1(1).
23. Butters, K., *How to Use the AIDA Formula*. 2013: <http://www.mysocialagency.com/>.
24. Bernays, E., *Propaganda*. 2004: Kindle Edition.
25. *Propaganda*, in *Oxford Dictionary of English (3. ed.)*, A. Stevenson, Editor. 2010, Oxford University Press.
26. Doob, L.W., *Goebbels' Principles of Propaganda*, in *The Public Opinion Quarterly*. 1950, Oxford University Press on behalf of the American Association for Public Opinion Research. p. pp. 419-442.
27. Jowett, G.O.D., Victoria, *Propaganda and Persuasion*. 2006: Sage Publications, Inc.
28. Rhetoric, E. *Ethos, Pathos & Logos – Modes of Persuasion (Aristotle)*. [cited 2016 02-02]; Available from: <http://www.european-rhetoric.com/ethos-pathos-logos-modes-persuasion-aristotle/>.
29. Mehrabian, A., *Silent Messages*. 1971, Belmont, CA: Wadsworth.
30. Mehrabian, A. *"Silent Messages" -- A Wealth of Information About Nonverbal Communication (Body Language)*. 1981 [cited 2016 05-01]; Available from: <http://www.kaaj.com/psych/smorder.html>.
31. Rhetoric, E. *Logos*. [cited 2016 02-02]; Available from: <http://www.european-rhetoric.com/ethos-pathos-logos-modes-persuasion-aristotle/logos/>.
32. Merriam-Webster, *Social psychology*, in *Merriam-Webster*. 2016.
33. Cialdini PhD, R.B., *Influence*. 2009, HarperCollins.
34. Bullée, J.-W.H., et al., *The persuasion and security awareness experiment: reducing the success of social engineering attacks*. *Journal of Experimental Criminology*, 2015. 11(1): p. 97-115.
35. Dahlgaard, S.M.P. and J.J. Dahlgaard, *Towards a holistic understanding of human motivation: core values—the entrance to people's commitment?* *AI & SOCIETY*, 2003. 17(2): p. 150-180.
36. AK, M., *Organizational responses to crisis: the centrality of trust.*, in *In R. Kramer & T. Tyler Trust in organizations: Frontiers of theory and research*. 1996, SAGE Publications Thousand Oaks, CA. p. pp. 261-287.

37. Maslow, A.H., *A theory of human motivation*. Psychological Review, 1943. **50**(4): p. 370-396.
38. Maxwell, J.C., *Everyone Communicates, Few Connect: What the Most Effective People Do Differently*. 2010, Thomas Nelson. Kindle Edition.
39. Carnegie, D., *How to Win Friends and Influence People* 2010, Ebury Publishing. Kindle Edition.
40. Tolle, E., *The Power of Now: A Guide to Spiritual Enlightenment*. 2010, New World Library.
41. Rhetoric, E. *Pathos*. [cited 2016 02-02]; Available from: <http://www.european-rhetoric.com/ethos-pathos-logos-modes-persuasion-aristotle/pathos/>.
42. Papadopoulos, D., *Positioning the roles, interfaces and processes in the information security scene*, in *Department of Computer Science and Media Technology*. 2013, Gjøvik University College.
43. Paul Cichonski, T.M., Tim Grance, Karen Scarfone, *Computer Security Incident Handling Guide*. 2012, National Institute of Standards and Technology.

Appendix 1 – Example of connecting optimisation techniques from different sources to factors in Metacom.

When different sources of information is used to find communication optimisation techniques, is it useful to compare them. Some information may overlap or be repeated. The quality of the information source may also be of varying quality. When the same information occur in different sources, it may indicate something about its credibility and importance. By connecting optimisations techniques from different sources to factors in Metacom, it is easier to compare, evaluate and integrate the optimisation techniques.

The example below show this can be done. The left column gives citation for the optimisation techniques/ advices in the right column. The main part of the text is copied from sections within this thesis.

The example includes only three of the optimisation factors from Metacom. A corresponding mapping for the rest of the factors would provide a more complete picture. Metacom and the information from these mappings, could serve as a foundation for a course to improve information security communication. The framework may also be used in the further development of communication optimisation techniques by integrating knowledge from other sources.

Factor 1: Communication strategy	
Source	Optimisation techniques/ advices
Propaganda by Bernays [24]	<ul style="list-style-type: none"> • The IS unit need to be aware of its relation to the public, to be successful in the end. • A good Relationship should be friendly and mutual beneficial. Conflicts and suspicion are damaging for both parties. • The IS unit must express its existence in a way that the public understands and make an effort to attain their interest, acceptance and approval. • It is important to convince them that the IS unit operate honest and fair, and acknowledge their demands. • The Communication strategy should support the PR of the IS unit. • It should state a consistent, enduring effort to create or shape events to influence the relations of the public to the IS group or an idea. • PR should be used consciously to create pictures and circumstances in the mind of the masses.
Propaganda by Goebbels cited in [26]	<ul style="list-style-type: none"> • One authority should control the Communication strategy. • It goals should be stated, e.g. change an idea in the public mind or change their behaviour.

	<ul style="list-style-type: none"> • For a IS unit the long-time Relationship is important. The Communication strategy should therefore underline the importance that all communication maintain the IS units credibility and authority. • It should also state that the PR consequence of an action must be consider before performing that action. It is easier to create circumstances instead of rationalise events.
Aristotle's Rhetoric [11]	<ul style="list-style-type: none"> • Communication strategy is not treated directly by Aristotle, but the Senders ethos can benefit from it.
Cialdini on Influence [33]	<ul style="list-style-type: none"> • Communication strategy is not treated directly by Cialdini, but the social psychology persuasion techniques may be used to strengthen its effect.
Summary	<p>A Communication strategy is necessary to become successful.</p> <ul style="list-style-type: none"> • It should be controlled by one authority. • It should have clear goals. • It should be used consciously to create pictures and circumstances in the mind of the masses. • It should be a consistent, enduring effort to create or shape events to influence the relations of the public to the IS group or an idea. • It should establish well-considered words, labels, phrases or slogans to be reused in the Messages. • It should seek to build a good long-term Relationship with the public. • It should express the IS unit in a way that the public understands and make an effort to attain their interest, acceptance and approval. • It should ensure that all communication maintain the IS units credibility and authority. • It should make sure that PR consequence always are considered in before actions are performed.
Remarks	<p>It can be observed that the Communication strategy is a high level plan to achieve some stated long-term goals. Some general goals would be to build good Relationships towards the public, to maintain own credibility and authority, and to influence the public towards certain ideas.</p>

Factor 5: Message	
Source	Optimisation techniques/ advices
Propaganda by Bernays [24]	<ul style="list-style-type: none"> • Since people do not like to be told what to do, it can be more efficient to send a Message that are working indirectly. By working through circumstances, the change in behaviour will come to the Receiver as his own idea. <p>11. Another method to influence a Receiver's attitude towards an idea is to use the associative process. By creating circumstances to link an idea with a good purpose, a happy event, a respected celebrity and so on, the status of the idea increase.</p>
Propaganda by Goebbels cited in [26]	<ul style="list-style-type: none"> • A Message should refer to real events when possible since this improve its credibility. • Visual images yield greater credibility than spoken or written words and thus improve Message efficiency. • It is also recommended Message repetition to strengthen learning, but avoid overdoing it since it then becomes boring. • Well-considered word may be very useful to increase efficiency. Labeling events and people with distinctive phrases or slogans helps to support the PR objectives. The use of carefully considered words might change the opinion of the Receiver(s). The phrases and slogans should possess certain characteristics to achieve this effect: <ul style="list-style-type: none"> ○ They must evoke desired responses which the audience previously possesses.” [26, p. 436] By using phrases, that link an event to some knowledge that people possess beforehand, the words can elicit the desired response. Phrases and slogans are used this way to explain news events, so the Receiver(s) interpreted it the “right” way. The PR then produces the desired feelings among the Receiver(s). ○ They must be capable of being easily learned. ○ Simplicity and repetition is important to facilitate learning, it must be painted in black-and-white to be convincing. ○ When the Receiver(s) are familiar with the verbal symbols, they should be used in every proper situation. ○ Special terms may be reserved for special occasions to keep their power.

	<ul style="list-style-type: none"> • The use of stories have to possibility to arise strong emotions among the Receiver(s) and can therefore be an effective way to pass on a Message. • It is also important to prevent the raising of false hopes, which can be blasted by future events. • PR can also be used to diminish the impact of frustration, by anticipate inevitable frustrations and place them in perspective. • If anxiety is used in the Message as a motivator, it must create an optimum anxiety level. Exaggeration may lead the Receiver(s) paralysed while to low anxiety may yield in inactivity, therefore a balance between to two extremes are recommended.
<p>The optimisation techniques in this row is assumed to be a part of Aristotle's Rhetoric [11], but they are collected from other sources and are therefore cited per bullet point.</p>	<ul style="list-style-type: none"> • Pathos can be used to influence the emotions of the Receiver(s). This reduce their ability to judge. Knowledge about the Receiver's values and believes are important to use pathos. There are several ways to form a Message, but certain use of language is best fit to create emotional reactions. Storytelling works different from lecture style. The use of exemplifications, illustrations, objects or representation of objects can be used to elicit emotions. [28] • It is difficult to make people change behaviour so it is most efficient to relate the change to something they already believe. This is called to use an anchor. "Anchors can be beliefs, values, attitudes, behaviors, and group norms." [27, p. 33]. • Some researcher's think that most human decisions are taken based on unconsciously and emotional processes. If that is so, pathos is a strong persuasive effect.[41] • Logos is concerned with the content, structure, and argumentation, when the Sender appeal to the Receiver(s) through logical reasoning. He will try to convince the Receivers that his arguments represents the truth. The goal is that the Message appear sound to the Receivers. It must not necessarily represent the truth, but appear to be truth for the Receivers. [31] • The composition of the Message is also related to the Channel. During a speech, the Receiver(s) cannot stop or pause to think through the arguments. The Sender must therefore live out complexity even if he is an expert on the topic. The arguments must be presented simple and clear so it is possible for the Receivers to follow the reasoning. [31] <p>Other Channels that carries written messages have other properties than the spoken and allow for more complex argumentation. [31]</p>
<p>Cialdini on Influence [33]</p>	<ul style="list-style-type: none"> • Research has shown that these persuasion techniques can increase the success of persuasion efforts significantly. The six categories are reciprocation, commitment and consistency,

	<p>social proof, liking, authority and scarcity. The Message can be formed to utilise these persuasion techniques to increase communication effectiveness.</p> <ul style="list-style-type: none"> • Reciprocation is about utilising human's disposition to give something back to when they receive a gift. The sender initiate this technique simply by giving the receiver a gift. Even when the gift is small, it puts the sender in an advantageous position. The receiver feels indebted and are therefore in a position where he wants to reciprocate the gesture. • Commitment and consistency take advantage of people's desire to appear as stable and crafty persons. Commitment refers to the fact that people normally stick to an idea or cause after an agreement or promise have been made. When they have taken a stand, they want to be consistent with this decision in later cases. • Social proof make use of human's tendency to act similar as other people. When making a decision people tend to look after what other people think is correct before they determine their own point of view. • Liking in central for influence. If the receiver knows and likes the sender, he is much more likely to comply with the sender's request. Humans tend to like other who share their interests, attitudes and beliefs. • Authority describe peoples tendency to comply with requests from figures that appear to be authoritative. • The scarcity techniques applies when something like a product, service or information appear to have limited availability. Then people tend to perceive these products as more valuable and desirable.
Dahlgaards's on motivation [35]	<p>10. Awareness of the Receiver(s) EC/ IC preferences may improve communication efficiency. The Sender should also be aware of his own preferences. Disregarding these aspects may increase semantic problems in the communication.</p> <p>11. A more sustainable motivation is obtained from intrinsic motivation. This insight could be used for communication efficiency by forming Messages that appeal to intrinsic motivation.</p>
Maxwell on connection [38]	<ul style="list-style-type: none"> • To be credible you must own the Message you seek to convey. Even if it is not your own originally, it is uttermost important to make it your own before you try to pass it on to others. When you own the Message, the verbal and non-verbal Message are aligned, it sends a strong Message of authenticity. • The Message should focus on the Receivers. • The Message could include that the Sender value and care for the Receivers.
Carnegie on	<ul style="list-style-type: none"> • The Message can be formed to make the Receivers feel better

human relations [39]	and increase their self-esteem by focusing on their best parts. A genuine appreciation of the Receiver will improve the Relationship and improve the efficiency of the communication.
Summary	<p>The Message is more than transmission of some information.</p> <ul style="list-style-type: none"> • It should be in-line with the Communication Strategy. • It should be authentic. • It should maintain or strengthen the Senders authority and credibility. • Message form is important. Storytelling works different from lecture style. The use of exemplifications, illustrations, objects or representation of objects can be used to elicit emotions. • Visual images should be used when possible. • It should be related to real events when possible. • It should use well-considered words, labels, phrases or slogans (connected to Communication Strategy). • It should be repeated to facilitate learning, but not too much must to avoid monotony. • It should be simple (painted in black and white). • It must balance the anxiety level, when anxiety is used as a motivator. • Ethos, Pathos and Logos should be considered when the Message is built. Pathos role in decision making should be considered. • The Message can be formed to utilise persuasion techniques as reciprocation, commitment and consistency, social proof, liking, authority and scarcity. • It should respect the properties of the Channel. • It should work indirectly, so it appear for the Receiver that it is their own idea. • It should be linked to beliefs, values, attitudes, behaviours, and/ or group norms with the Receiver. • It should show genuine respect and care for the Receiver. • It should appeal to intrinsic motivation and preferably make the Receiver feel better by increasing their self-esteem. • It should never seek to diminish the Receiver.
Remarks	The Message implements the Communication Strategy. It always work with the Relationship and influence it, even when the main purpose of the communication is to achieve something else. Therefore, the Message's influence on the Relationship should be considered, when it is shaped. A Message that result in short-term gain may lead to a major future loss if it make damage to the Relationship. Fairness should therefore be a part of any Message.

Factor 10: Relationship	
Source	Optimisation techniques/ advices
Propaganda by Bernays [24]	<ul style="list-style-type: none"> • A good Relationship should be friendly and mutual beneficial. Conflicts and suspicion are damaging for both parties. • The IS unit must express its existence in a way that the public understands and make an effort to attain their interest, acceptance and approval. • It is important to convince them that the IS unit operate honest and fair, and acknowledge their demands. • PR is all about Relationship. It seek to manipulate every factor in order to create a favourable Relationship towards the target Receiver(s). Communication efficiency is the goal and Relationship is acknowledged as a key factor to achieve it
Propaganda by Goebbels cited in [26]	<ul style="list-style-type: none"> • For a IS unit the long-time Relationship is important. The Communication strategy should therefore underline the importance that all communication maintain the IS units credibility and authority. • It should also state that the PR consequence of an action must be consider before performing that action. It is easier to create circumstances instead of rationalise events.
Aristotle's Rhetoric [11]	<ul style="list-style-type: none"> • Ethos is the credibility and authority of the Sender towards the Receivers. It can thus be seen as an important part of the Sender's relationship towards the Receivers. Therefore, any optimisation efforts need to keep the Receiver(s) in mind and assess how it will affect the Relationship. • To be credible the Sender must show competence, good intention and empathy.
Cialdini on Influence [33]	<ul style="list-style-type: none"> • Research has shown that these persuasion techniques can increase the success of persuasion efforts significantly. The six categories are reciprocation, commitment and consistency, social proof, liking, authority and scarcity. These persuasion techniques can also be utilised to build and maintain Relationships. • Reciprocation is about utilising human's disposition to give something back to when they receive a gift. The sender initiate this technique simply by giving the receiver a gift. Even when the gift is small, it puts the sender in an advantageous position. The receiver feels indebted and are therefore in a position where he wants to reciprocate the gesture. • Commitment and consistency take advantage of people's desire to appear as stable and crafty persons. Commitment refers to the fact that people normally stick to an idea or cause after an agreement or promise have been made. When they have taken a stand, they want to be consistent with this decision in later cases.

	<ul style="list-style-type: none"> • Social proof make use of human’s tendency to act similar as other people. When making a decision people tend to look after what other people think is correct before they determine their own point of view. • Liking in central for influence. If the receiver knows and likes the sender, he is much more likely to comply with the sender’s request. Humans tend to like other who share their interests, attitudes and beliefs. • Authority describe peoples tendency to comply with requests from figures that appear to be authoritative. • The scarcity techniques applies when something like a product, service or information appear to have limited availability. Then people tend to perceive these products as more valuable and desirable.
Dahlgaards’s on motivation [35]	<ul style="list-style-type: none"> • Most important factors when we work with others: openness, honesty, responsibility, trustworthiness, being positive, loyalty, respect and integrity. These factors build good Relationships. • Critical barriers that prevents cooperation between people: dishonesty (unreliability), irresponsibility, being negative, disloyalty, arrogance and egotism. These factors damage Relationships. • Good Relationships leads to intrinsic motivation and is the most sustainable form for motivation.
Maxwell on connection [38]	<p>Connection is a prerequisite for any Relationship.</p> <ul style="list-style-type: none"> • Authenticity is a key factor to obtain connection. When the verbal and non-verbal Message are aligned, it sends a strong Message of authenticity. • Maxwell’s general principles to connect are then in our communication terminology (how to build good Relationships): <ul style="list-style-type: none"> ○ the Sender recognize the value the Receiver(s) ○ the Sender focus on the Receiver(s), not his own ego ○ the Sender make the Receivers (s) perceive that he genuinely care for them ○ the Sender shows that he can provide something useful for the Receiver(s) ○ the Sender is trustworthy • Recognising the Receiver(s) means to focus on them in the communication and find out about their values. Then there is possible to build the Relationship on common values. • To bring “a gift” or do a service for others strengthen the Relationship more than words. • Maxwell state that the Sender must be aware that it requires energy to connect to the Receiver(s) and that he must be willing to bring this energy.
Carnegie on human	<ul style="list-style-type: none"> • When the Relationships improve, the communication efficiency will increase.

relations [39]	<ul style="list-style-type: none"> • Motivation is often connected to actions, which makes people feel better. A Sender can contribute to a Receiver's self-esteem by focus on their best parts. A genuine appreciation of the Receiver will improve the Relationship and improve the efficiency of the communication. • An attack of the Receiver's self-esteem diminish or block the communication efficiency. • The ability to appreciate other people genuinely, rely upon an unselfish behaviour.
Summary	<p>A good Relationship is a prerequisite for efficient communication.</p> <ul style="list-style-type: none"> • It should be friendly and mutual beneficial. Conflicts and suspicion are damaging for both parties. • It should never diminish the Receiver's self-esteem. • It should build and maintain long-time credibility and authority of the Sender towards the Receiver. • The Relationship effect of any actions should be considered, before they are performed. (Actions that damage the Relationship can then be avoided). • The Sender (or his unit) must express its existence in a way that the public understands and make an effort (bring energy) to attain their interest, acceptance and approval. • The Sender (or his unit) must acknowledge the Receivers demands and show that he can provide something useful. By providing some "gift" or service he may strengthen the Relationship. • Authority should be back up by competence. • Good Relationships should be built on common ground. People tend to like they who share their interests, attitudes and beliefs. • The Sender must be authentic in his actions and genuinely appreciate the Receivers. This requires unselfish behaviour. • The Sender should bring core values like openness, honesty, responsibility, trustworthiness, being positive, loyalty, respect and integrity into the Relationship. • An exclusive Relationship may increase the Receivers perceived value of it.
Remarks	<p>Relationships exists between people, groups or organisations on many levels. Within the context of this thesis, the focus is on how a Sender can optimise his communication towards certain Receivers. The Relationship is one of the factors he can improve. The Sender can do this by regulating his own attitude and behaviour. His ability to improve the Relationship will improve when he is able to obtain information about the Receiver. The Sender authenticity is very important to support his credibility both in a short and long-time perspective and maintain the Relationships.</p> <p>Important Relationships should be given special attention. Still</p>

	authenticity and genuinely appreciation of the Receivers should be brought to any Relationship. Trust is the foundation of any Relationship.
--	--