



**NTNU – Trondheim**  
Norwegian University of  
Science and Technology

# Optimal Drilling and Completion of Deep ERD Wells

**Christian Bue**

Petroleum Geoscience and Engineering (2 year)

Submission date: December 2013

Supervisor: John-Morten Godhavn, IPT

Norwegian University of Science and Technology  
Department of Petroleum Engineering and Applied Geophysics





**NTNU – Trondheim**  
Norwegian University of  
Science and Technology

## MASTER DESCRIPTION

### *Background*

Today most wells in deep waters are drilled vertically, while many wells in the North Sea are highly deviated. Studies have shown that recovery can be increased significantly if highly deviated extended reach wells can be drilled and completed also in deep waters.

### *Work Description*

1. Literature study: Describe different completion solutions used in deepwater drilling.
2. Case study: Use Statoil regulations (technical requirements and guidelines) to design a production well. Use Landmark's WellCat to simulate the demands for the material. Then, simulate drilling and completing of the reservoir section using materials that meet the demands. If such a material does not exist, suggest material specifications that needs to be present (With help from Auristela C. V. Quintero at Statoil). Investigate different scenarios, including gas kick and full gas displacement.
3. If possible, try to optimize the use of liner and wellpath in regards to weight/strength and pressure demands.
4. Discussion

**Supervisor: John-Morten Godhavn, Statoil ASA**



# *Abstract*

Faculty of Engineering Science and Technology  
Department of Petroleum Engineering and Applied Geophysics

Master of Science

## **Optimal Drilling and Completion of Deep ERD Wells**

by Christian Bue

In this Master Thesis well design for deepwater ERD wells have been reviewed. These wells present new challenges for the industry, which creates high demands for well design and materials. The constant push for “deeper” deepwater wells makes optimization critical. A literature study on deepwater completions has been done.

Factors impacting the well design have been investigated through simulations in Landmark’s WellCat. The design has been based on Statoil design requirements and API calculation theory. A self-built model has been developed to simulate the well performance for a well located in the Gulf of Mexico. The chosen well has a water depth of 2,300 m and a reservoir pressure above 1,350 bar (20,000 psi). It is thus classified as a High-Pressure High-Temperature well. The well is designed as an Extended Reach Well.

Well design is dependent on several factors, such as: pressure and temperature, production plans (e.g. gas lift), water depth, present formations and their hydrocarbon content. Different requirements exist depending on where in the world the well is located, and for different expectancies for hydrocarbons in the different sections. These factors and requirements influence on well design have been studied. The study showed that the two requirement documents available were not modified for deepwater wells. Gaps in the present technology were identified and, where possible, suggestions for improved performance were made.

A WellCat model was implemented to simulate the loads in the given well. A drillability study was done for the reservoir section. Some parameters were varied to investigate the changes in the well design. Based on these results a final well design for the given well was found. Two new pipes would have to be made to handle the high pressures in the well.



# *Samandrag*

Fakultet for Ingeniørvitenskap og Teknologi  
Institutt for Petroleumsteknologi og anvendt geofysikk

Master i teknologi

## **Optimal Boring og Komplettering av Djupe Høgavviksbrønner**

av Christian Bue

I denne masteroppåva er formgjeving av høgavviksbrønner i djupt vatn undersøkt. Desse brønnane introduserer nye utfordringar for industrien, og sett høge krav til brønndesign og til materiala som blir brukt. Den konstante utviklinga mot djupare djupvassbrønner gjer optimalisering høgst nødvendig. Eit litteraturstudie på kompletteringsløyseringar i djupt vatn er gjennomført.

Faktorar som påverkar brønnformgjevinga er undersøkt. Dette er gjort ved hjelp av Landmark si programvare, WellCat. Formgjevinga er basert på Statoil sine “designkrav”, samt teori for API-kalkuleringar. Ein sjølvbygd modell laga for å simulere lastene i ein brønn i Mexicogulfen. Den valgte brønneren har eit vassdjup på 2300 m, og eit reservoartrykk på over 1350 bar (20000 psi). Dette er klassifisert som ein høg-trykk høg-temperatur-brønn. Brønneren er bygd som ein høgavviksbrønn.

Brønntutforming er avhengig av fleire faktorar. Dette inkluderer; trykk og temperatur, produksjonsplanar (t.d. gassløft), vassdjup, formasjonane i brønneren og hydrokarboninnhaldet i desse. Ulike krav er gjeldande etter kvar i verda brønneren er lokalisert, og for ulike forventingar til om hydr karboner er venta i dei ulike seksjonane. Inverknaden frå desse faktorane og krava er undersøkt. Studiet viste at dei to tilgjengelege formgjevingskrava (designkrava) ikkje er tilpassa djupvassbrønner. Det er prøvd å identifisere eventuelle hol i noverande teknologi. Der det var mogleg blei forslag for forbetringar føreslått.

Ein sjølvbygd modell blei brukt for å simuelere lastene i den valgte brønneren. Eit studie på om brønneren kunne borast og kompletterast er gjort for reservoarseksjonen. Variering av nokre parameter blei gjort for å sjå kva innverknad dei hadde på brønnformgjevinga. Basert på desse resultatata blei eit endeleg forslag til brønnoppbygging føreslått. To nye røyr må lagast for å kunne takle dei høge trykka i brønneren.





# *Preface*

This Master Thesis is written in the fulfilment of Master of Science through the course “TPG4910 Drilling Engineering, Master Thesis” at the Norwegian University of Science and Technology (NTNU). The title is 'Optimal Drilling and Completion of Deep ERD Wells' and the thesis is written by Christian Bue. Where work or publications from others are referred to, or help and guidance has been given, this is clearly stated. The thesis is written in co-operation with professor John-Morten Godhavn and Statoil, represented by Ketil Inderberg and Auristela C. V. Quintero. Good advice on Statoil regulations were given by Dag Johan Eiane in Statoil. The thesis is handed in with gratitude to the above-mentioned supervisors.

A specialization project on Wellpath Optimization for ERD Wells in Deep Waters was carried out in the spring of 2013. This project raised new questions regarding the completion aspect and it was decided it would be interesting to carry out a Master on the subject.

I would like to give a special thanks to Harald Røstad and Alasdair Fleming at Lyngaas TMC. Without their guidance and help through the process, the thesis would not have been finished in time.



# Table of Content

- Abstract** **i**
- Samandrag** **iii**
- Preface** **v**
- 1 Introduction** **1**
- 2 Completions in Deep Water** **2**
  - 2.1 General . . . . . 2
  - 2.2 Lower Well Completions . . . . . 12
  - 2.3 Sand Exclusion Completion . . . . . 18
  - 2.4 Completions for Special Applications . . . . . 26
  - 2.5 Optimal Completion in Theory . . . . . 33
- 3 Stress Analysis** **35**
  - 3.1 Stress Analysis . . . . . 35
  - 3.2 Design Basis . . . . . 40
- 4 Results** **47**
  - 4.1 Well Design . . . . . 47
  - 4.2 Drillability . . . . . 50
  - 4.3 Sensitivities . . . . . 52
- 5 Discussion and Evaluation** **61**
  - 5.1 Deepwater Challenges . . . . . 61
  - 5.2 Simulation Results . . . . . 61
  - 5.3 Design Requirements . . . . . 68
  - 5.4 Optimization . . . . . 71
  - 5.5 Model Evaluation, Source of Errors and Future Work . . . . . 72
- 6 Conclusion** **76**
- Bibliography** **77**
- Abbreviations** **81**
- Nomenclature** **82**
- List of Figures** **85**
- List of Tables** **89**

## Appendices

<b>A</b>	<b>Stress Analysis Equations</b>	<b>A-1</b>
A.1	Burst . . . . .	A-1
A.2	Collapse . . . . .	A-1
A.3	Triaxial Analysis . . . . .	A-4
A.4	Equations and Calculations . . . . .	A-4
<b>B</b>	<b>System Description</b>	<b>A-8</b>
B.1	System Specifications . . . . .	A-8
B.2	WellCat Setups . . . . .	A-11
B.3	WellPlan Setups . . . . .	A-12
<b>C</b>	<b>Simulation Modelling Procedures</b>	<b>A-15</b>
C.1	WellCat Procedure . . . . .	A-15
C.2	Load Case Setups . . . . .	A-23
<b>D</b>	<b>Simulations</b>	<b>A-29</b>
D.1	Well Design - 9 7/8" liner and Tieback . . . . .	A-29
D.2	Well Design - Base Case . . . . .	A-39
D.3	WellPlan Simulation . . . . .	A-46
D.4	Sensitivity Simulation . . . . .	A-49
<b>E</b>	<b>Literature Study - Additional Information</b>	<b>A-50</b>
<b>F</b>	<b>Software</b>	<b>A-55</b>
F.1	Compass <sup>TM</sup> . . . . .	A-55
F.2	Wellplan <sup>TM</sup> . . . . .	A-55
F.3	WellCat <sup>TM</sup> . . . . .	A-55

# Chapter 1

## Introduction

The constant push for deeper deepwater operations makes optimization critical. This push involves both deeper water and depth. Due to the deep water, wells in GoM are usually drilled with little or no hole deviation. However, knowing that horizontal and multilateral solutions will give the highest net present value, an incentive exist to optimize the well design for such deep, advanced ERD wells. As the reservoir depth only represents the starting point for lower completions, this introduces new challenges to the drilling arena. New developments are therefore needed in ERD technology, including drilling systems, fluid systems and string components. A study on drilling and well design in deepwater wells is therefore considered interesting to investigate the demands in these wells.

One of the challenges that has risen from this drive to go deeper is that existing casings cannot handle the pressure and/or temperatures from the reservoirs. Therefore, new casings have to be developed with the necessary grade and strength. Heavier casings further increase the demand for rig capacity and drilling/running procedures. This forms the basis for this study, which is looking into details regarding well design and the resulting casing requirements in such wells.

Understanding and establishing a good model to simulate the performance of a production well in these environments is therefore critical. The following items were listed as goals for this thesis.

- Perform a literature study on completions in deepwater environments.
- Design a production well based on Statoil requirements. Use Landmark's WellCat to simulate the demands for the material.
- If the demands cannot be met by present technology, identify the gap. If possible, suggest specifications for improved performance.
- Evaluate the present requirements and suggest improvements with the goal of more general requirements for deep waters.

To answer these questions a search in literature was carried out to find field experience and theoretical work on deepwater completions. Thereafter, a model was built based on the requirements from Statoil. The model was applied on a specific well in the Gulf of Mexico to investigate the demands based on present requirements. The formation pressure in the well was close to 1,400 bar (20,000 psi), which provides an excellent base for investigating general requirements for deepwater HPHT-like wells.

# Chapter 2

## Completions in Deep Water

Once drilled, evaluated, cased and cemented, a well has to be *completed*. This is done by inserting equipment, designed to optimize production, into the hole. Completing a well does not always include tubing or a Christmas tree, or any other piece of equipment. It may, for example, be possible to produce up the casing from an open hole. However, as the industry moves into more hostile environments such as deepwater or the Arctic, the challenges mount and completions become more complex. Whichever complexity, all completions are driven by the goal of recovering as large a percentage of the Original Oil in Place (OOIP) as possible, at a reasonable cost.

### 2.1 General

Variations of the completions deployed in shallow wells are also used in deepwater wells. With exception to tension leg or spar type platforms, most deepwater wells are subsea. The biggest difference with deepwater completions is driven by economics. (Wetzel et al., 1999) Most of the immense costs of drilling and completing deepwater wells is associated with the rig time. They require large-diameter tubing and often artificial lift systems to be able to produce them. (Bellarby, 2009)

The length and complexity of the landing string, and the time required to run this, impose a great challenge when installing deepwater subsea completions. Along with the high rig rates, this sums up to be expensive if done wrong. Using horizontal trees avoids the complexity of a dual landing string for a hanger vertical tree. (Bellarby, 2009)

Deepwater wells include long, large-diameter risers which are particularly difficult to clean. Many of the operational problems associated with completions is related to debris from the riser BOP or from milling operations. (Bellarby, 2009)

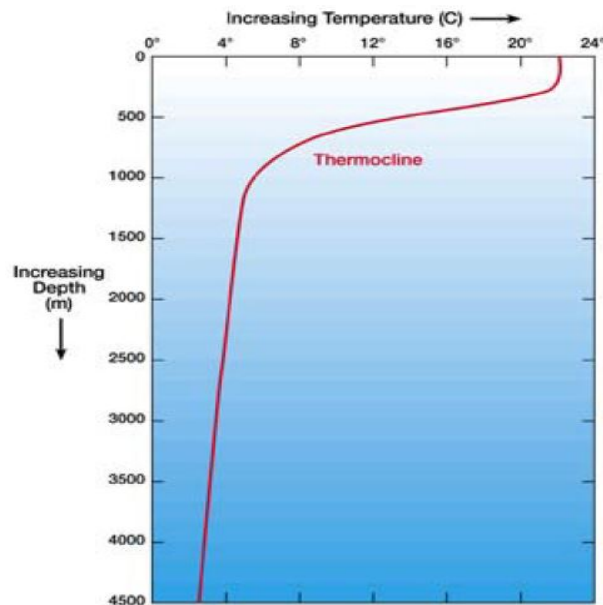
In the following sections, different solutions for completing a well will be presented. They will be described in general terms to give an overview of the different solutions. In most cases, deep details will not be provided, as such depth would require more time and would not be applicable for the thesis objective. In addition, a short introduction will be made to deepwater characteristics and challenges associated with completing wells in deep waters.

#### 2.1.1 Deepwater Operations and Challenges

The petroleum industry are moving into increasingly deep waters, which demands increasingly efficient execution. The water temperature at the seabed is low, with a non-linear temperature gradient. All these deepwater characteristics add further challenges to the already difficult issues in drilling. They impact every aspect of the well construction.

In this section, a short description will be given of deepwater characteristics and the challenges that follows.

Deep water is in this thesis defined as deeper than 500 m (Rae and Di Lullo, 2004). Ultra-deep water is defined as water depth above 1,500 m. (Rocha et al., 2003b) One of the main characteristics of deep waters are the low temperature. Figure 2.1 shows a typical temperature profile for deepwater areas such as the Gulf of Mexico (GoM).

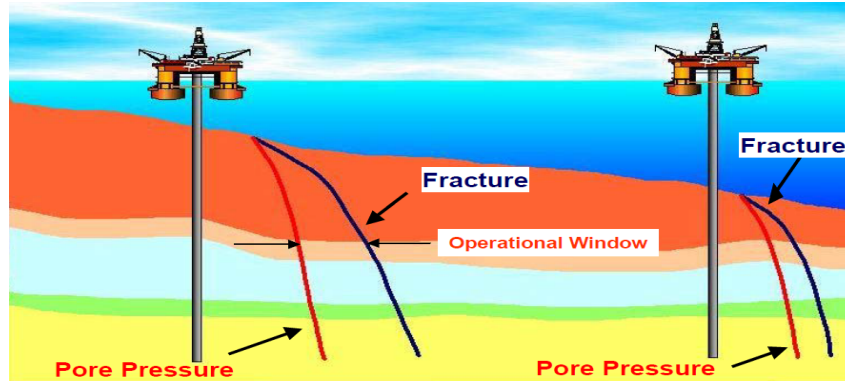


**Figure 2.1:** Temperature versus depth in deep water. (Rae and Di Lullo, 2004)

The temperature is close to 0 °C at the mudline - some waters even have below 0 °C, but do not freeze due the high salinities and high pressures. Due to these low temperatures, flow assurance are often necessary. This includes preventing wax and hydrates. In addition, it has implications for stimulation, completion fluid density, cementing and stress analysis. (Bellarby, 2009) The enormous body of cold water lowers the temperature of the rock strata. This effect may go as deep as 500 m below the seabed, and create temperatures much lower than the ones predicted by normal geothermal gradients. (Rae and Di Lullo, 2004)

The most recognized deepwater challenge is probably the narrow pressure window while drilling. This is caused by the high water column which lower the overburden stress, resulting consequently in a relatively low stress regime and a smaller tolerance between pore pressure and fracture pressure gradient. The rock becomes structurally weak, low compacted, with high portions of unconsolidated sediments (mainly in the shallow portion of the underground). (Rocha et al., 2003b) Figure 2.2 shows the pore and fracture pressure gradients as a function of depth for two different water depth scenarios. The fracture pressure gradient in deep water decreases more than in shallow water due to reduction in overburden pressure gradient. As the water depth increases, the operational window will decrease. (Rocha et al., 2003b) ECD control is critical to maintain wellbore stability, since loss of mud often is seen. (PetroWikiSPE, 2006, b) One way of overcoming the narrow pressure window is by using a dual-gradient system and lightweight additives. Lightweight Solid Additives (LWSA) are used to reduce the density of drilling fluid within

the riser. Drilling with LWSA reduce the number of casing strings required, the tension load requirements on the riser, and the mud storage requirements on the drilling vessel. This reduce the demand for size of drillships or increase depth capability of existing vessels. (Watson et al., 2005)



**Figure 2.2:** Pressure window (Rocha et al., 2003b)

The sediments that are located in the shallow parts of the seabed are young and has low overburden. This results in low compaction and cohesion. Collapse and other mechanical failures during drilling is therefore highly likely. To avoid losses, low mud weights must be used, sometimes even as low as seawater. Since low mud weights often is required to avoid losses, the risk is increased if shallow gas is encountered. Shallow gas is however less of a problem in deep waters due to the high backpressure provided by the long water column. This high pressure limits the expansion in or around the well. Gas will undergo approximately 2.5% volumetric expansion in a 1,250 m (4,100 ft) well with 1,200 m (4,000 ft) water column (50 m sub-seabed). Compared with a typical shallow water well of 100 m (350 ft) with a 60 m (200 ft) water column, the gas will expand approximately 33%. (Rae and Di Lullo, 2004)

Shallow gas should not be confused with shallow water flows, which is a much more dangerous geohazard in deep waters. This is due to the very high permeability and the over-pressured layers, which, together, can create enormous flow rates in the under-compacted rock. (Rae and Di Lullo, 2004) Water-bearing sands are typically located in the first 600 m below the mudline and are highly permeable. As this section often is drilled in riserless mode, stopping the flow is difficult, and often include pumping thousands of barrels of weighted WBM that returns to the sea floor. (Offshore Magazine, 2000)

The low temperatures at the seabed decreases the cement hydration rate as temperature decreases. This causes the cement to set more slowly as water depth increases. It also exist a great salt water and gas flow potential at these depths. If the cement does not develop adequate gel strength in the early stages of hydration, it can cause fluid influx in shallow zones. The slurry hydration temperature and the density is limited by the seabed temperature and the low fracture gradient. The narrow pressure window between the pore pressure and the fracture gradient often limits the circulation rates that are ideal for hole cleaning and cement placement. In addition, the annulus size is often large, causing reduced velocity. All these limitations calls for optimization in order to achieve efficient hole cleaning and cement placement. (Ravi et al., 1999)



The long water column creates high hydrostatic pressure at the mudline. In addition to the cold temperatures, this creates significant challenges for production. This is particularly an issue in start-ups and shutdowns. Most of them are associated with the subsea flowlines and facilities. There are however some associated with the completion. The combination of low temperature and high pressure drives the hydrate envelope down the well. This affects the setting depths of safety valves and their control system.

The long risers needed to cover the long distance between the rig and the sea floor introduces a significant increase in weight of steel. In addition, the casing strings required for these wells have substantial weight, and typically does not allow much overpull during casing running operations. The large volumes in the riser is another challenge. Circulation becomes more time consuming and mud swaps become logistically difficult. (Watson et al., 2005) The aspect of hydraulics in these deep waters are also a complex issue. The long distance causes large friction losses, which cause the hydraulics performance to degrade considerably. Additional pump power and pump rates are often required to keep the well and the riser clean. (Rocha et al., 2003a) The subsea equipment is commonly controlled by hydraulic pressure in control lines, which run from the rig down to the equipment. This means that, in deep water, the time it takes for a command to be executed is much longer than in shallow waters.

Extended reach wells may be needed in deepwater drilling to reach target reservoirs. The ratio between horizontal displacement and TVD (DTVD) is often used to classify directional wells. Well classification could be as presented in Table 2.1.

**Table 2.1:** Well Classification (Rocha et al., 2003a)

DTVD		Classification
From	To	
0	2	Conventional Directional Well (Non-ERW)
2	3	Extended Reach Well (ERW)
3	-	Severe Extended Reach Well (S-ERW)

Hole cleaning is critical in high angle sections, especially in sections with inclination between 40° and 65° (due to cutting beds and sliding). With inclination above this, the cuttings will slide and accumulate just above the BHA, which can cause packoff and stuck pipe situations. Due to the low fracture pressure gradients in deep waters, the normal procedures used in ERW, including higher flow rates, mud viscosities and pipe rotation, may not always be applicable. The solution may be to decrease the rate of penetration to avoid excessive ECD's. (Rocha et al., 2003a)

Deepwater and ultra-deepwater wells face challenges in all drilling phases. In the shallow section, where soft soil is the main characteristic, a move from conventional drilling, to jetting the conductor pipe in place, has been required. This is to avoid sinking of the wellhead. In the deeper sections, the narrow pressure window is the main problem. Circulation loss and well bore instability is always an issue, and often limits the length of the well.

### 2.1.2 Well Barriers

Every well operation includes a well control envelope. Completions are usually part of this envelope, and will remain so through the life of the well. A general rule for well control is that “at least two tested **independent** barriers between hydrocarbons in the reservoir and the environment shall be present at all times”. (Bellarby, 2009) The two barriers can be divided into “primary” and “secondary” barrier. The primary is defined as “the barrier that initially prevents hydrocarbons from escaping”. This may include the mud, the Christmas tree or the tubing. The secondary barrier is defined as “the backup to the primary barrier - it is not normally in use until the primary barrier fails”. (Bellarby, 2009)

Strong regulations to testing and maintaining of the barriers exist. These regulations can be found in the Norwegian standard, NORSOK D-010. Examples of barrier systems during various phases of well construction and operation are shown in Table E.1.

### 2.1.3 Cementing

The characteristics of deep waters add further challenges to the design of cementing operations. In particular, challenges regarding the properties of cement slurry - such as heat of hydration. In this section, cementing will be presented.

To get the best protection from the outside, as well as permanently positioning the casing into place, it is cemented in place. This consist of pumping cement slurry into the well, displace the drilling fluid and fill the space between the casing and the actual sides of the well. The cement can consist of an easy mix of water and bulk cement, or include a special mixture of additives. This is to obtain different properties, such as hardening time, chemical reaction, etc. (Rigzone, n.d., b) Cement requires short thickening time, rapid development of mechanical properties, cope with the risk of influx and provide a long term hydraulic seal, amongst other things. The low temperatures and other aspects of deep waters makes this difficult for the cement. This has driven the research and development of cementing systems. (Rae and Di Lullo, 2004)

The objectives when cementing in deep waters differ little from other cementing operations conducted in shallower waters. The difference lies in the seabed environment. The overall objectives are to avoid influx of formation fluids, develop strength in the shortest time possible (to achieve economic objectives) and be placed without being lost to the formation. (Ravi et al., 1999)

Due to the small margin between pore pressure and fracture pressure only lightweight cements can be used. Most lightweight cements do not meet the specifications needed to get a successful cement job. They normally have higher water:cement ratios than normal density cement. In addition, they take longer to set and gain strength. To cope with this, a number of approaches have been developed. A short description of these are given below. They include (Rae and Di Lullo, 2004):

- Foamed cement.
- Microsphere cement.
- Optimized particle size distribution (OPSD) cement.
- Reactive lightweight aggregate cement.
- Liquid colloidal aggregate cement.

**Foamed Cement** (Rae and Di Lullo, 2004)

This type consists of a conventional “base” cement, which is pumped with gas, typically nitrogen. The gas is then compressed under hydrostatic pressure. As the gas has low density it enables the foam slurries to have good quality and be relatively dense. This assures good setting characteristics and excellent mechanical properties once set. It is compressible, rather viscous and tend to resist flow. The first mentioned provides a measure against the volumetric changes caused by leakoff and cement hydration since it expands slightly. Finally, foamed cement is rather ductile when set, which is beneficial when the stresses induced by thermal effects can comprise bonding and sheath integrity.

**Microsphere Cement**

Blending low density, hollow microspheres into the cement provides a strong, lightweight cement. These microspheres are typically composed of a silica shell and contain nitrogen or CO<sub>2</sub>. This makes it possible to prepare slurries with very low densities. However, at such low densities, very large amounts of the microspheres are needed. This requires large storage capacities when mixed as a dry blend. Gravity segregation is also very likely. One way of eliminating such problems is to add the microspheres to the mix water, instead of blending them dry first. (Rae and Di Lullo, 2004)

**Optimized Particle Size Distribution (OPSD) Cement**

This method involves preparing blends of cement with a variety of specifically-sized lightweight aggregates. The distribution of particles is carefully selected, giving the final blend a high final solid content, volumetrically. Due to the lower-than-normal porosity, systems with this formulation have low innate permeability, and due to the low water/high solids content, they have significantly higher strength. A disadvantage by using OPSD cement is that it is very inflexible. By definition, it requires a specific solid volume fraction. It can therefore only be mixed in a very narrow density range. This creates problems if for example the pore pressure is higher than expected. (Rae and Di Lullo, 2004)

**Reactive Lightweight Aggregate Cement**

Most lightweight cement slurries have less strength than neat systems. This is due to the extra water, along with the diluting effect of the aggregates. However, some lightweight aggregates react chemically with the cement slurry components, to generate new cementitious materials. This adds to the final strength of the set product. These reactive lightweight aggregates must in most cases be blended in dry form, and thus, they are limited by the same problems as the OPSD systems. (Rae and Di Lullo, 2004)

**Liquid Colloidal Aggregate Cement**

To improve the efficiency of chemical reactions, their accessibility to one other is improved. Techniques to enhance mixing and mass transfer, or using catalysts to selectively bring reactants in close proximity, is therefore used in many chemical processes. Using colloidal particles maximizes the contact area between reactants. This aqueous suspension in which the particles of the dispersed phase are very small, with typical surface area ranging from a few square metres per gram up to many hundred of square metres per gram. They make slurries more stable with excellent properties. As they are administered as colloidal liquids, the design can be varied across a wide range of densities, which provides a great advantage. (Rae and Di Lullo, 2004)

Due to the low seabed temperature and the effect of this on cement hydration kinetics, conventional lightweight cement slurries that are based on Class G or Class H cements, are generally unsuitable for use in deep water. However, not all deepwater wells require these special cement systems. In some areas, traditional cement systems are used with good success. (Rae and Di Lullo, 2004)

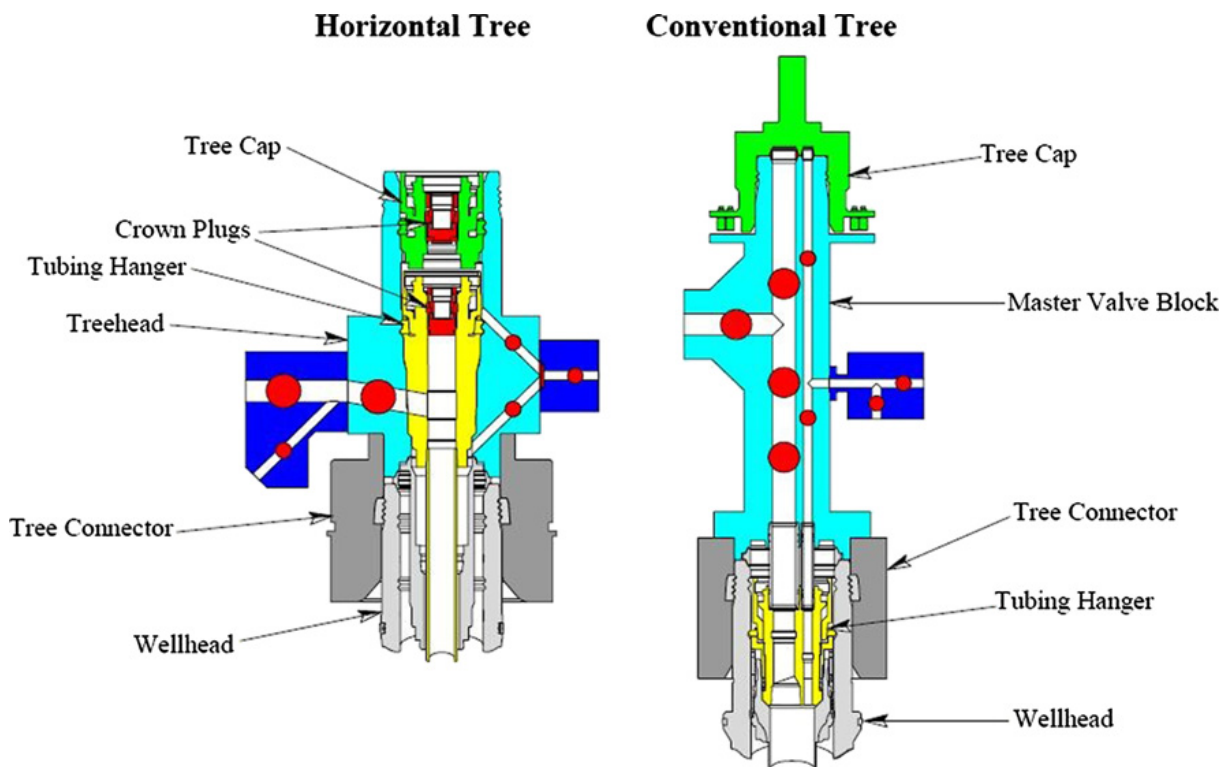
## 2.1.4 Completion Equipment

### 2.1.4.1 Tree and Tubing Hanger

After the well has been drilled, the production tubing and the Christmas tree are installed. All naturally flowing wells, in addition to artificial lifted wells uses a Christmas tree. This is to provide the primary method of closing in a well, be able to connect a flowline and to provide access for well intervention. (Bellarby, 2009)

There are two types of Christmas trees; conventional (vertical) and horizontal trees. The main difference between these is the position of the valves. In a horizontal tree, the master valves are horizontal and away from the production bore, whilst in a vertical tree, they are in a vertical position and in line with the tubing. The installation sequence is also different. (Sangesland, 2012)

When using a horizontal X-mas tree the completion is run after installing the tree. The BOP is put on top of the X-mas tree. When removing the BOP, tree-plugs are required before it can be removed. These are placed inside the tubing hanger. (Bellarby, 2009) Using horizontal trees makes it possible to replace the tubing without retrieving the tree. (Sangesland, 2012) Figure 2.3 shows both types of Christmas trees.



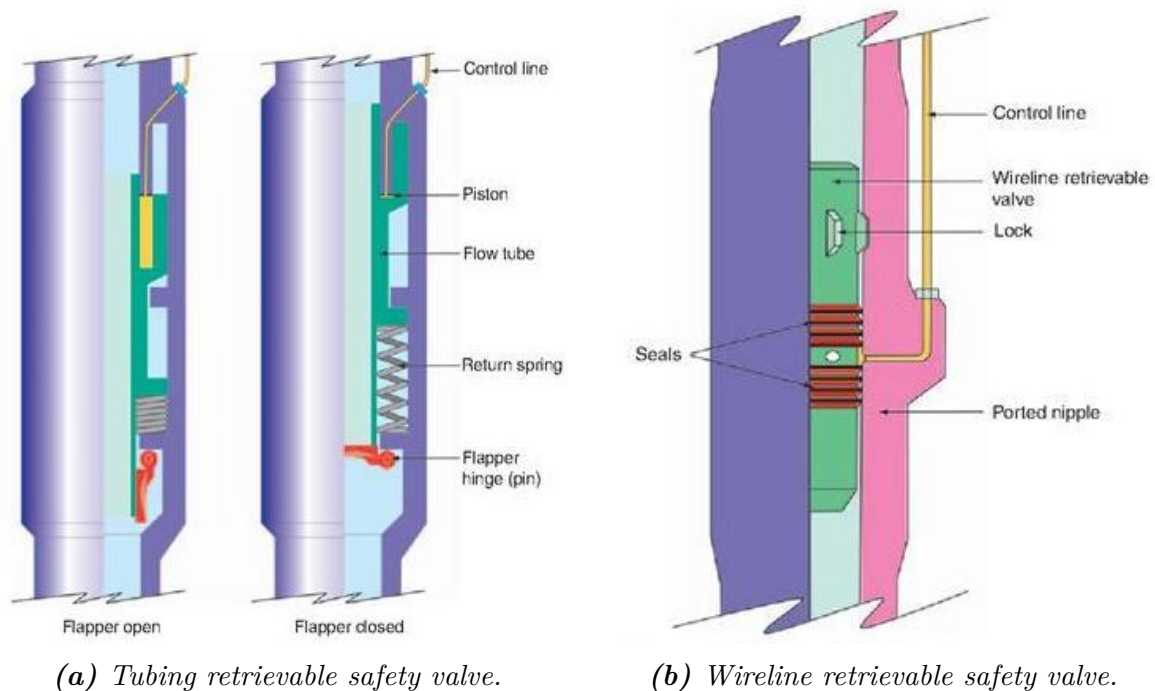
**Figure 2.3:** Horizontal and vertical Christmas tree. (Hachana, 2012)

In vertical trees, the tubing hanger and tree are dual bore. This involves an annulus access bore for controlling the “A-annulus”. Since this type of tree requires access to both the production and annulus bores to remove the plugs, a dual-bore riser must be used. Horizontal trees only require a single-bore riser. (Bellarby, 2009)

### 2.1.4.2 Subsurface Safety Valves

Subsurface Safety Valves (SSVs) are valves designed to prevent an uncontrolled flow of hydrocarbons from the well. This type of valves are normally hydraulically controlled, and work as a backup system to the tree. The valves should not be tied to the shut-down system. This keeps the valves open during most shut-downs except complete loss of power. (Bellarby, 2009)

There are several types of SSVs. The most used in modern completions are tubing retrievable valves, which are more reliable than wireline retrievable versions. (Bellarby, 2009) Figure 2.4 shows a figure of these two types.



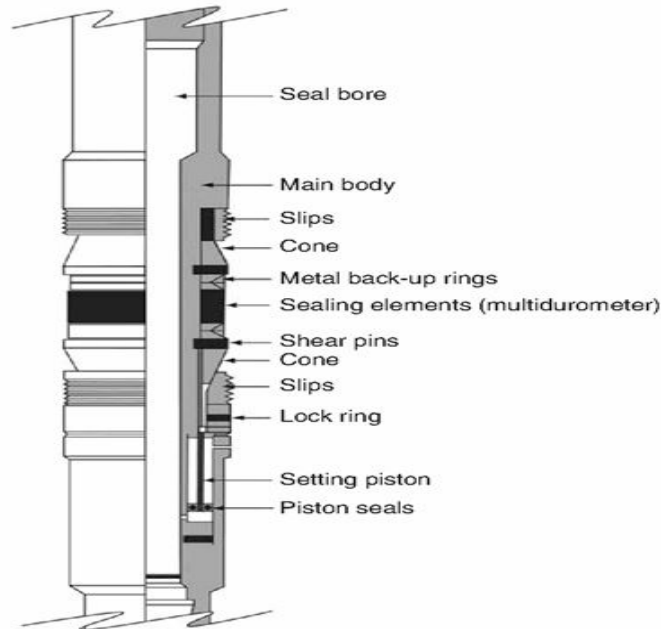
**Figure 2.4:** Downhole safety valves. (Bellarby, 2009)

### 2.1.4.3 Packers

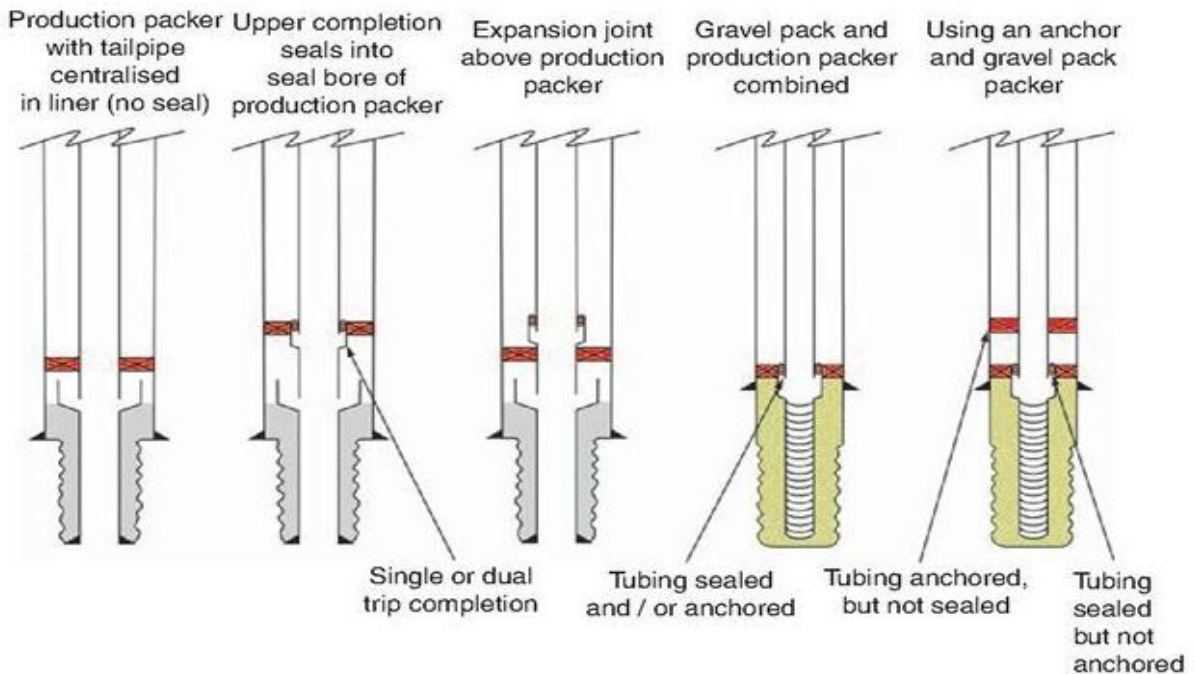
Packers have two purposes; (1) provide a structural purpose and (2) provide a sealing purpose. They are used to isolate the annulus or isolate different production zones. In addition, they may be used to isolate gravel and sand. Different packers exist for the different purposes. A gravel pack packer is for instance unsuitable as production packer, although there are some developed for a multipurpose service. (Bellarby, 2009)

Packers are often set hydraulically, although they can be set mechanically as well. If it is set hydraulically, it is done with a differential pressure between the annulus and the tubing. Figure 2.5 shows a hydraulic set production packer.

Packers can be permanent or retrievable. Retrievable packers are replaced by a straight pull, whilst permanent packers requires the upper part to be milled down to the slips. Packers are discussed more in Section 2.2.1.3 on page 15. Figure 2.6 shows different configurations for packers.



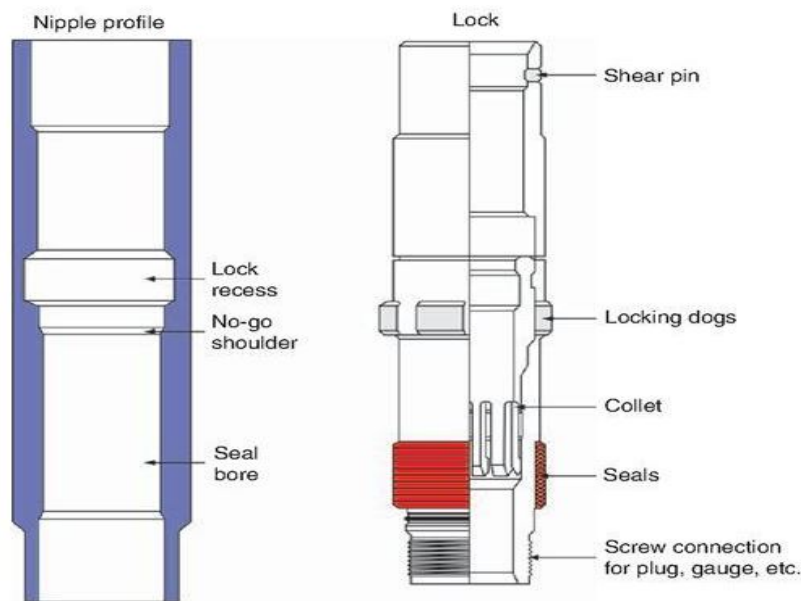
**Figure 2.5:** Typical hydraulic set production packer. (Bellarby, 2009)



**Figure 2.6:** Packer configurations. (Bellarby, 2009)

#### 2.1.4.4 Landing Nipples, Locks and Sleeves

When wireline (and occasionally coiled tubing) tools are deployed into the completion, some kind of system must be used to lock and seal it off. Such applications include plugs for pressure testing, check valves, deployment of downhole chokes, to mention some. These devices can be landed by two approaches; (1) using a pre-installed nipple profile in the completion, and running a lock into this. A blanking plug, standing valve, gauge, etc. can be attached to the lock. (2) A packer deployed on a wireline, which can be set anywhere in the tubing. A plug, standing valve, gauge, or similar is attached to the packer. (Bellarby, 2009) Figure 2.7 shows an example of a nipple profile and associated lock.



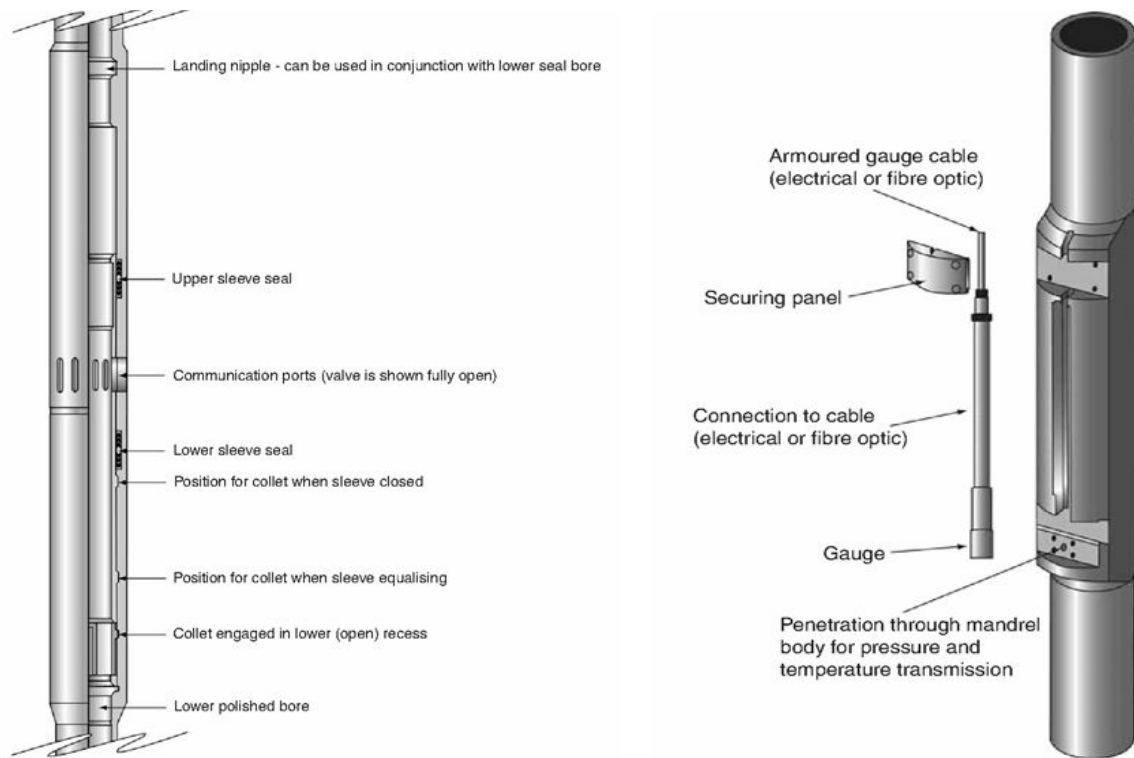
**Figure 2.7:** Nipple profile and lock. (Bellarby, 2009)

The no-go is present for positive depth control. It is for location only, not load bearing. The landing nipples can be positioned on different locations. Examples are; in the tubing hanger, as part of a downhole safety valve, mid position of tubing, sliding sleeve and above/below a packer or seal. (Bellarby, 2009)

#### 2.1.4.5 Mandrels and Gauges

Mandrels allows for connection of valves and gauges to the completion. It is a permanent attachment to the side of the completion. Side pocket mandrels can be used in gas lift wells, and are either round or oval in cross-section. They may also be used for circulation purposes. Mandrels can according to Bellarby (2009) be used for downhole gauges. Because of the complexity, the gauge is permanently connected to the mandrel. Figure 2.8b shows an example of this.

Permanent downhole gauges are used for many reasons; assessing well connectivity, determination of connectivity to a gas cap or aquifer, quantification of formation damage, and several more. (Bellarby, 2009)



(a) Sliding sleeves.

(b) Permanent downhole gauge.

**Figure 2.8:** Mandrel and gauge. (Bellarby, 2009)

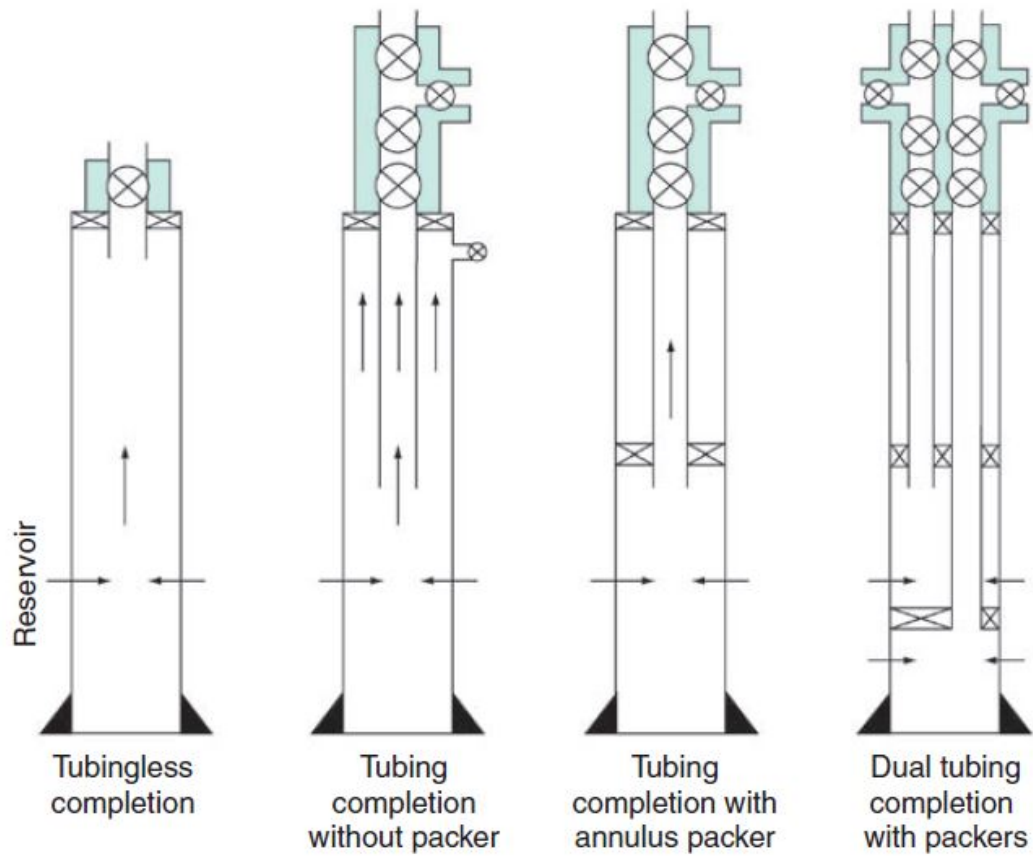
## 2.2 Lower Well Completions

“Completion” refers to the process of finishing a well. The selection of which system to use is directly influenced by a number of factors. Firstly, whether the well is to be a producer or an injector. Oil, gas and water can be produced, water, steam and waste products - such as carbon dioxide and sulphur - can be injected. More than one purpose can be present, and the number of possibilities is thus large.

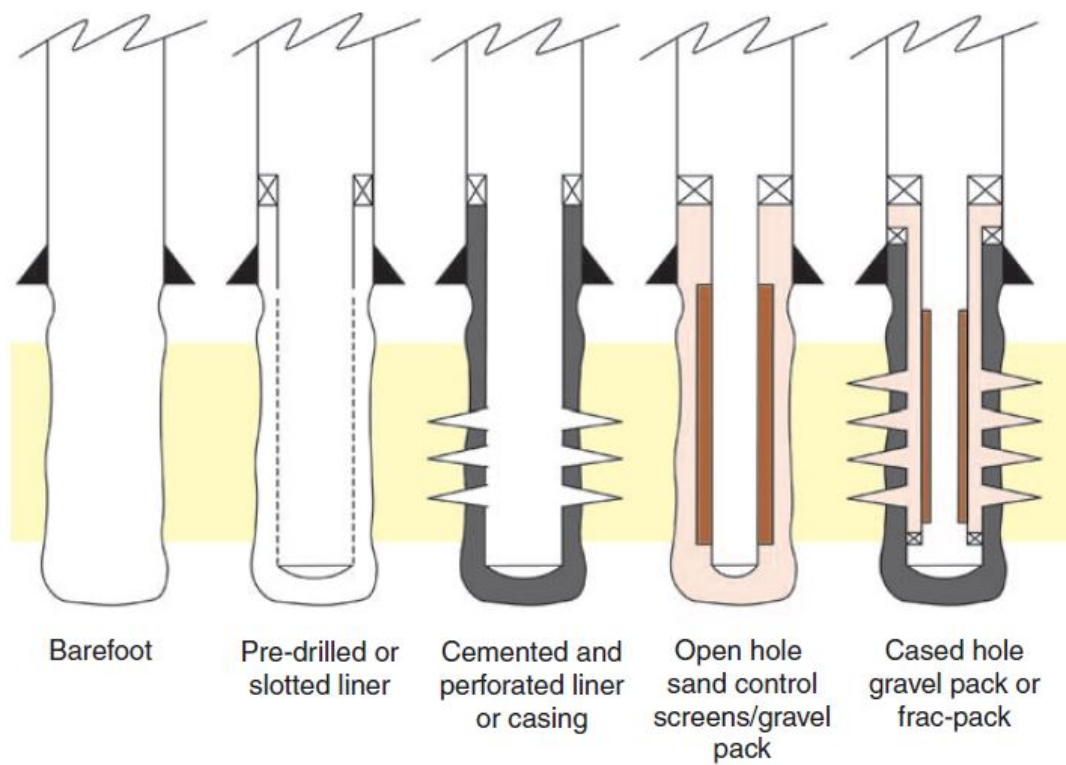
Completions are often split into two groups; (1) reservoir or lower completion, and (2) upper completion. The lower completion is the connection between the reservoir and the well. The upper completion is the conduit from reservoir completion to surface facilities. The major decisions that needs to made in regards to reservoir completion are; open hole versus cased hole, sand control requirement and type of sand control, stimulation and single or multi-zone. Choices for upper completions; artificial lift and type, tubing size, single or dual completion and tubing isolation or not (packer or equivalent). (Bellarby, 2009)

In the following sections an introduction will be made to the different solutions for lower well completion. Upper well completions will only be shortly mentioned in this thesis. Figure 2.10 and Figure 2.9 shows some of the main solutions for reservoir completions and upper completions, respectively.





**Figure 2.9:** Upper completion methods. (Bellarby, 2009)



**Figure 2.10:** Reservoir completion methods. (Bellarby, 2009)

## 2.2.1 Openhole Completion

This is the most basic type of completion. It consists of simply running the production casing down to the top of the reservoir, leaving the formation section uncased. Since this leaves the end of the piping open without any other protective filter, it is mostly used in formations that are unlikely to cave in. This way of completion removes control of flow of fluids from the formation, and is thus unsuitable for weak formations which may require sand control. (Rigzone, n.d., b)

There are several varieties in the term *open hole completions*; barefoot completions, pre-drilled and pre-slotted liners and open hole sand control techniques. In addition, many of the simpler multilateral systems use open hole reservoir techniques.

All open hole completions avoid the cost and complexity of perforating. Open hole (and cased hole) sand control is covered in Section 2.3 on page 18. Multilateral systems are covered in Section 2.4.2 on page 26.

### 2.2.1.1 Barefoot completions

Barefoot completions are common in competent formations such as naturally fractured limestones and dolomites. There are several advantages involved using this technique beyond the obvious low cost and maximum pay zone exposure (Bellarby, 2009);

- Well deepening and sidetracking are easier to perform without equipment such as screens present. They are particularly well suited to techniques such as Through-Tubing Rotary Drilling (TTRD).
- The technique is naturally used in simple multilateral wells such as a TAML<sup>1</sup> level 1 or the branches of a level 2 system.
- Decreased drawdown. (Rigzone, n.d., b)
- Less formation damage. (Rigzone, n.d., b)

The main disadvantage is the lack of control over gas and water production, inability to plug of water or gas zones, inability to selectively stimulate the separate zones within the productive interval. (Rigzone, n.d., b) See Figure 2.10 for a basic sketch of a barefoot completion.

### 2.2.1.2 Pre-drilled and pre-slotted liner

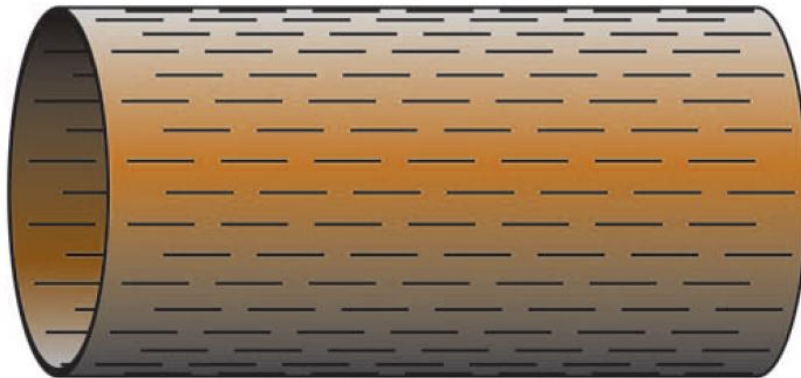
In pre-drilled liners the liner is pre-holed with multiple small holes. It is inserted into the zone of production when doubt exist to the wellbore stability. Pre-drilled or pre-slotted liners are not typically used as a sand control measurement as it is difficult to make the slots small enough to stop sand. The purposes of using this type are to stop hole collapse and allow zonal isolation packers to be deployed within the reservoir completion. (Bellarby, 2009) Examples of such packers are swelling elastomers, mechanical packers and external casing packers. (Danilovic et al., 2006)

Slotted liners are an alternative to pre-drilled liners. These include multiple longitudinal slots, for example 2 mm X 50 mm, spread across the length and circumference of each

---

<sup>1</sup>Technology Advancement of MultiLaterals (TAML) is discussed in Section 2.4.2 on page 26

joint. The compressional strength is affected by the slots as the rigidity is reduced. The tensile strength is not severely affected. (Bellarby, 2009) Figure 2.11 shows a slotted liner.



**Figure 2.11:** Pre-slotted liner. (Bellarby, 2009)

Pre-drilled liners are generally preferred to pre-slotted liners as they have much larger inflow area and are stronger. Problems such as pressure drops through the holes and plugging are therefore not a concern. (Bellarby, 2009)

Installing a pre-drilled or pre-slotted liner is done with or without a washpipe. When sand control is not required, the liner is usually installed in mud. This removes some of the concerns about surge and swab or mechanical abrasion. The whole mud and filter cake is then produced through the liner. (Bellarby, 2009)

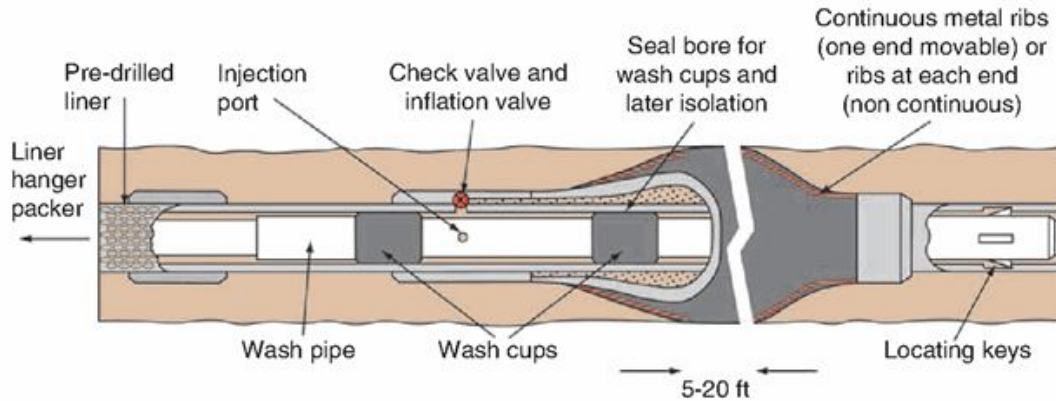
### 2.2.1.3 Zonal Isolation Techniques

The difficulty with zonal isolation is one of the key disadvantages with any open hole completion. Although pre-drilled liners can be used with gel and cement treatments, the chance of success is low. To cope with this, additional equipment has to be installed with the liner. External Casing Packers (ECPs) and swellable elastomer packers are most commonly used for this. (Bellarby, 2009)

#### External Casing Packers (ECPs)

The potential isolating horizons - usually shales - dictate which ECPs to be used. It is paramount to get the liner to the required depth to use this equipment. Once the liner hanger has been set and the washpipe pulled back to the ECP depth, the ECP is inflated via the washpipe. Mud is used to inflate the packer. (Bellarby, 2009)

There are two challenges with ECPs; (1) they rely on the full integrity of elastomers under downhole conditions, (2) there will be movement, which causes potential abrasion. Cement could be used instead of mud to mitigate some of these concerns. ECPs do not anchor to the formation, while conventional packers do. Pressure testing is also difficult. Due to these challenges, other types of packers are preferred. Swellable elastomer packers are becoming more common, as well as mechanical open hole packers (similar to production packers), which are now becoming available. (Bellarby, 2009) Figure 2.12 shows an external casing packer.



**Figure 2.12:** External casing packer. (Bellarby, 2009)

### Swellable Elastomer Packers

This type of packer is relatively new technology. The elastomer is bounded to the outside of the pipe through vulcanization<sup>2</sup>. Since elastomers swell in the presence of oil or water, the packer is run in an inert fluid. Previously, this property was considered a disadvantage. Now, however, it is used as a sealing mechanism. Since there is no need for specialized installation equipment, swellable elastomer packers have an advantage over the ECPs. Further, they do not need inflating, they can be run with screens or with pre-drilled or pre-slotted liners. Even further applications include cased hole and barefoot workovers, underbalanced completions and combinations with expandable solid tubulars. Their application is wide and is becoming increasingly attractive. (Bellarby, 2009)

The swelling takes some time to reach full expansion, up to 40 days, and can more than double the packer volume. Some packers swell in the presence of reservoir oils and are therefore well suited for use with completion brine. Packers used in gas wells may need circulation in a base oil. The swelling often becomes more effective in high temperatures. (Bellarby, 2009) Figure 2.13 shows a swellable elastomer packer.



**Figure 2.13:** Swellable elastomer packer. (Bellarby, 2009)

<sup>2</sup>Vulcanization is a chemical process for converting rubber into more durable materials via the addition of sulphur or other equivalent “curatives”. (Vulcanization, n.d.)

## 2.2.2 Cased and Perforated Completions

Cased and perforated completions are used extensively in offshore areas. (Bellarby, 2009) The use for sand control with cased hole gravel packs and frac packs are discussed in Section 2.3 on page 18.

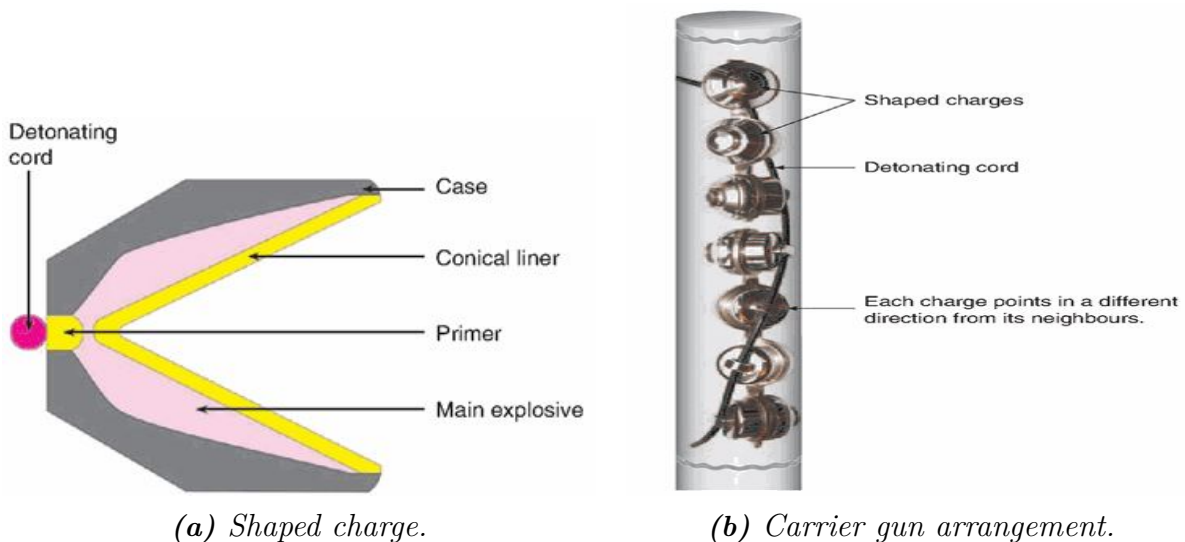
Several advantages exist of the cased and perforated completion over the open hole completion. Some of them are mentioned below (Bellarby, 2009):

- Ability to shut-off water, gas or sand.
- Excellent productivity. Drilling-related formation damage can usually be bypassed.
- Suitable for fracture stimulation.
- Reduced sanding potential through perforations being smaller than a wellbore.
- Ability to add zones at a later stage.

However, it has increased costs. This is especially the case for high angles or long intervals. (Bellarby, 2009)

### 2.2.2.1 Perforation

The majority of perforated wells use a shaped charge. There are still some that use the bullet perforator, however as a niche application. The shaped charge creates a very high pressure, which is focused in one direction by the conical liner. It is designed to penetrate the casing, the cement and the formation. Figure 2.14a shows the components of the shaped charge, while Figure 2.14b shows the typical configuration inside a perforation gun. (Bellarby, 2009)



**Figure 2.14:** Perforation. (Bellarby, 2009)

In most cased and perforated completions the aim is to generate the maximum perforation length. This is achieved by using shaped charges that have relatively tight conical geometry. Many choices can be made in regards to types of explosives, geometry and size. This will not be discussed in detail in this thesis.

## 2.3 Sand Exclusion Completion

Formations that are poorly consolidated may contain loose formation grains and other fine particles. This may require a filtration system to keep the wellstream clear of sand, without sacrificing productivity or flow control. These completion systems are designed to allow flow of hydrocarbons, but at the same time prevent sand from entering the well. This is done by including a screening or filtering system. These systems may be either a type of screen hung inside the casing, or a layer of specially-sized gravel outside the casing. Both of these can be used in open holes and perforated completions. Techniques like these must be matched to the physical characteristics of the reservoir. (Natural Gas, n.d.)

According to Walton et al., 2002, 90 % of hydrocarbon wells are in sandstone reservoirs, and around 30 % of these sandstones may be weak enough to produce sand. If production of sand is unexpected, it could lead to loss of integrity, erosion and be detrimental to the productivity of the well. The ability to predict whether sand control equipment is needed or not is therefore fundamental to design a successful well. Details in rock strength and production prediction will not be discussed in this thesis.

Sand exclusion methods often reduce well productivity, which gives great incentive to develop new techniques for sand control. One of these new techniques involves sophisticated oriented-perforating techniques that can aid in the work against sand production.

### 2.3.1 Sand Control Screen Types

The vast amount of commercially available screens can be subdivided into three main types: Wire-Wrapped Screens (WWS), Pre-Packed Screens (PPS) and premium screens (sometimes called mesh or woven screens). As mentioned in Section 2.2.1.2, slotted liners can also be used for sand control. However, it is difficult to get slots small enough to stop smaller items but the coarsest of formations. (Bellarby, 2009)

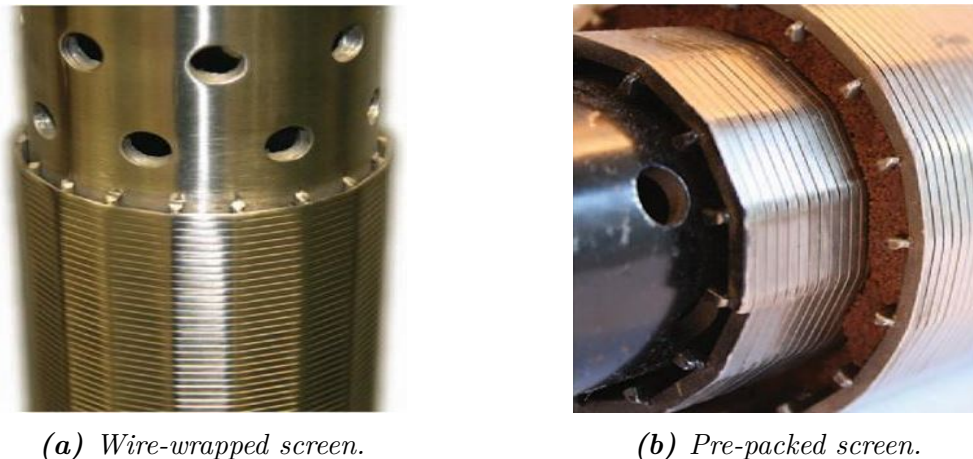
All forms of screen have an optimum environment, although they could be run in either cased hole or open hole well - with or without gravel packing. If additional installation protection is needed, screens can also be run into open hole with a pre-installed, pre-drilled liner. (Bellarby, 2009)

#### 2.3.1.1 Wire-wrapped Screens

These screens make a base pipe with holes, longitudinal rods and a single wedge-shaped wire wrapped and spot-welded to the rods as shown in Figure 2.15a. They are frequently used in gravel pack and standalone completions. The wire is wedge shaped, ensuring that particles bridge off against the wire or pass right through for production. Due to this shape the wire provides a degree of self-cleaning. The inflow area is dictated by the slot width, the wire thickness and the percentage of screen joint that comprises slots. When used in gravel pack completions, the WWS stops the gravel, which in turn may stop the fine materials. (Bellarby, 2009)

### 2.3.1.2 Pre-packed Screens

PPS and WWS are constructed in almost the same way, PPS with two screens instead of one. Figure 2.15b shows a picture of a PPS. The slots are designed to prevent the escape of gravel packed between the screens. Gravel packs has the fundamental advantage that they prevent sand failure and stand transport by removing the annulus between the screen and formation. A PPS does neither of these and must therefore not be confused. Gravel packs will be discussed in Section 2.3.2. PPS can be installed with an outer *shroud* to provide some installation protection and jetting resistance. This will however increase the thickness. PPS has past its time of greatness, but still remain in use in some parts of the world.



**Figure 2.15:** Two type of screens. (Bellarby, 2009)

### 2.3.1.3 Premium Screens

Premium screens include woven mesh and some form of shroud for protection. Figure 2.16a and Figure 2.16b shows two different designs. They include multiple woven layers. This type of screens are thinner than PPS and thicker than WWS. They typically have an inflow of around 30%. Robust construction makes them very suitable for harsh installation environments such as long, horizontal, open hole wells.



**(a)** Example of premium screen.

**(b)** Typical construction.

**Figure 2.16:** Premium Screens (Bellarby, 2009)

### 2.3.2 Standalone Screens

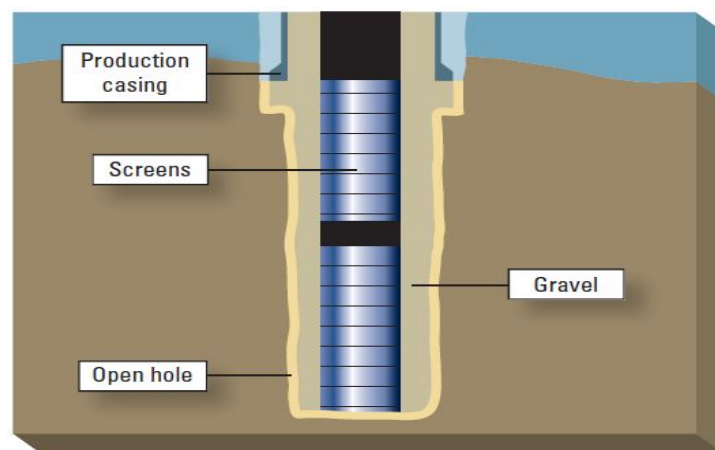
Standalone Screens (SAS) are simplistic in use and has low installation costs. The aforementioned WWS, PPS and premium screens are all used as standalone screens. Blank sections of pipe and external casing packers are often incorporated when using these screens. Sometimes they are the only form of sand control possible to use in Extended Reach Wells (ERW) or in many types of multilateral wells. Mud is usually conditioned or replaced prior to running the screens. Washpipe inside the screen is therefore not required. (Bellarby, 2009)

Annular flow is believed to effect the SAS reliability. ECPs and swellable elastomer packers are therefore often used to reduce annular flow. (Bennett et al., 2000)

### 2.3.3 Open Hole Gravel Packs

Open hole gravel packs are very common in deviated and horizontal wells. They require no perforation, and present a good option in highly productive deepwater completions. (Schlumberger, 2007) The basis of this method is to pack the annular space with gravel, keeping the sand from being produced. The gravel has to be sized in the right way for this to be effective, as well as sizing the screen to prevent the gravel from escaping. The gravel is round natural or synthetic material that is small enough to exclude formation grains and particles from production, but large enough to be held in place by screens. (Schlumberger, 2007) They are operationally challenging to install, however, when successfully installed, they prevent the formation from collapsing. (Bellarby, 2009)

Skin effects is a general problem for gravel packs (both open hole and cased hole). This dimensionless factor is calculated to determine the efficiency of the production by comparing the actual conditions with the theoretical conditions. A positive skin value means that it exist some kind of effect that is impairing the well productivity, while a negative value means enhanced productivity. Placement of gravel-packs can lead to high positive skin values in a well. This is often due to problems in packing the perforation tunnels, which may lead to a detrimental pressure drop between the formation and the well. (Schlumberger, 2007) Open hole gravel packs can be subdivided into two main forms: circulating packs and alternate path (shunt tubes). Both can be used with PPS, WWS and premium screens. (Bellarby, 2009) Figure 2.17 shows a schematic of an openhole gravel pack.



*Figure 2.17: Openhole gravel pack (Schlumberger, 2007)*

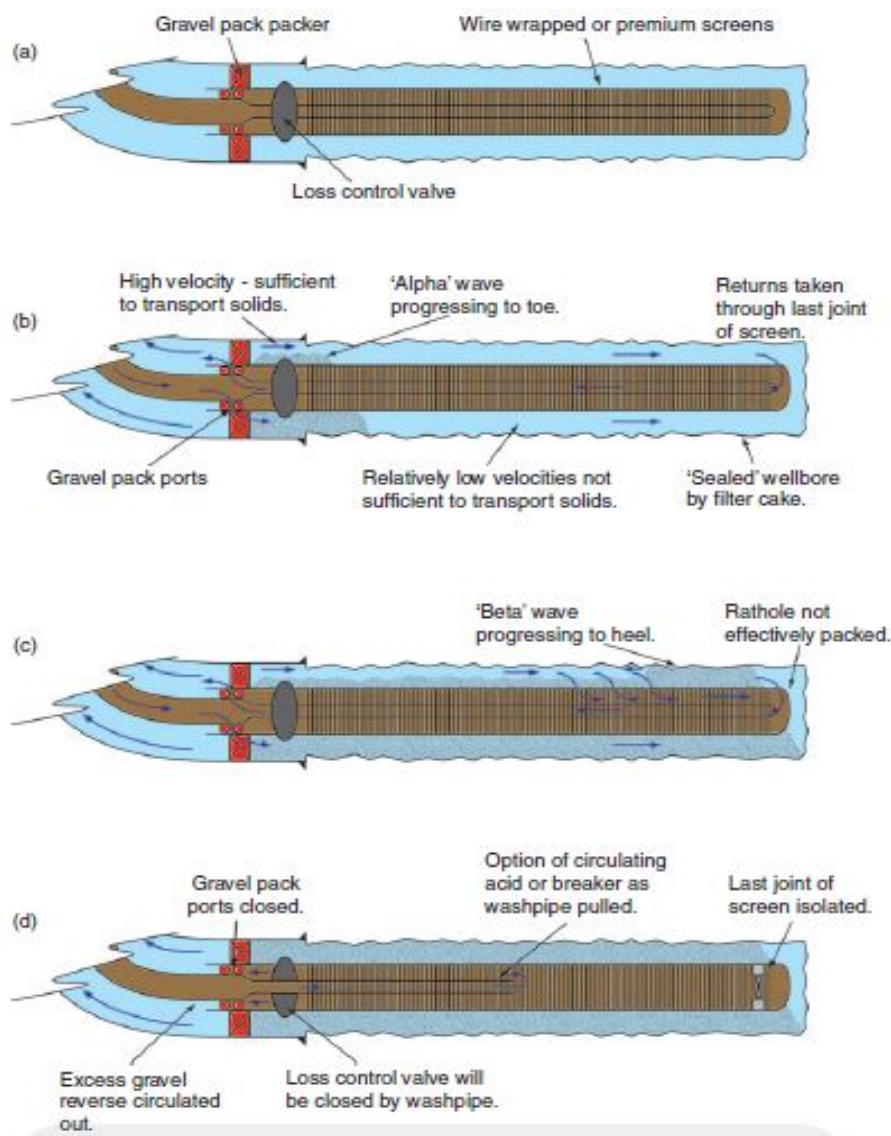


### 2.3.3.1 Circulating Packs

This method is widely used - especially in areas such as offshore Brazil. Figure 2.18 shows a typical sequence for a horizontal well. There exist many variations of this sequence, although with a common fundamental requirement; a hydraulically isolated formation, which means that the filter cake must remain intact during the gravel packing. If this requirement is not present, the gravel pack fluid will be dehydrated by the losses causing the alpha wave to stall. This creates a sand bridge between the formation and screen, thus preventing gravel from packing downstream of the bridge. (Bellarby, 2009)

Water-based muds is preferred when using circulating packs. However, in some cases, oil-based mud has to be used to overcome challenges in the well. Alternate path pack may be more suited in these environments as these are more capable of dealing with severe hole stability and losses. (Bellarby, 2009)

The main argument for switching to alternate path pack, which is more complex, is the requirement to avoid losses when using circulating packs. (Bellarby, 2009)

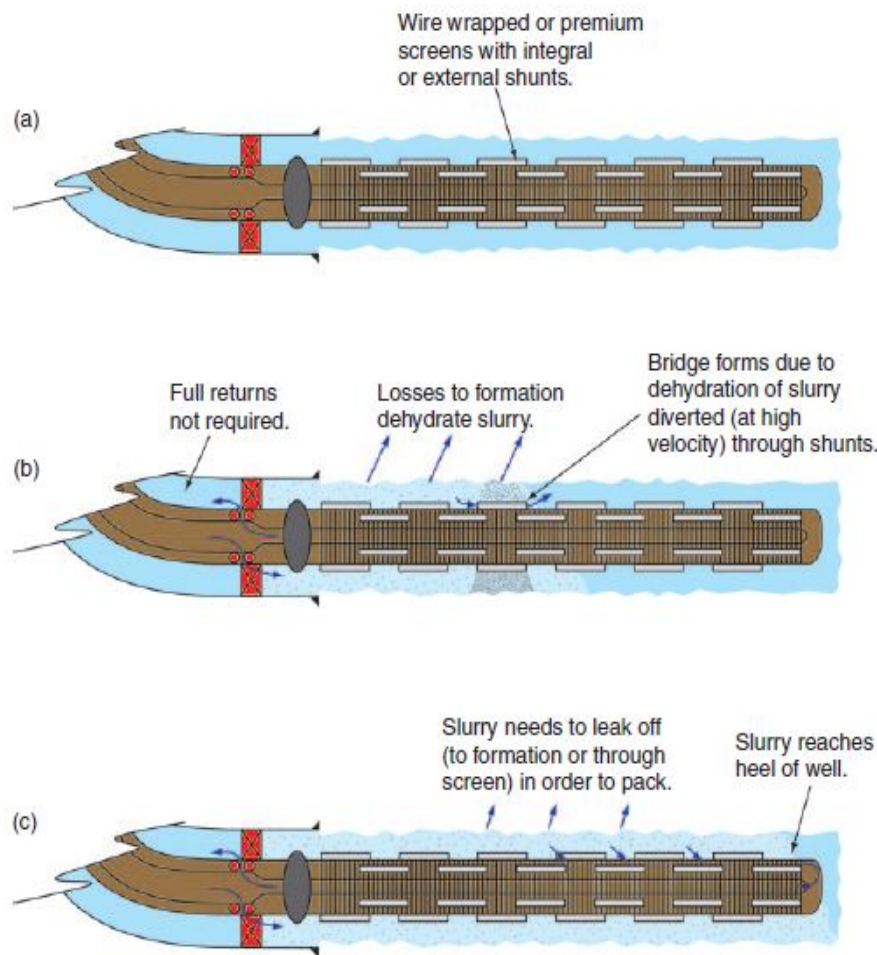


**Figure 2.18:** Circulating pack sequence. (Bellarby, 2009)

### 2.3.3.2 Alternate Path Gravel Packs

Alternate path gravel packs are used where losses or annular blockages cannot be avoided, and are thus more flexible than circulating packs. The differences between the two types are presented in Table E.3 in Appendix E. There are however some fundamental differences worth mentioning: (Bellarby, 2009)

- A viscous fluid is used to transport the gravel. More chemicals are required - but pump duration and liquid volumes are shorter.
- Full returns are not required. Damaging the filter cake may, in some cases, be encouraged to help cleaning the well.
- Dehydration of the carrier fluid is still a concern. To prevent gravel bridges or hole collapse, the slurry gets an alternate path via shunt tubes. These tubes provide a high-velocity bypass around obstructions. They are attached to, or are incorporated into, the screens. Figure 2.19 shows an alternate path gravel packing with shunts.



**Figure 2.19:** Alternate path gravel packing with shunts. (Bellarby, 2009)

The shunt tubes can be designed in a number of ways - but usually they are rectangular or crescent in cross-section. The shunts have multiple (3 to 6) alternate paths, each with holes regularly positioned along them. To prevent blockages, these holes are at least five

times larger than the mean gravel diameter. The shunts can be organized in different patterns such as parallel or spiral patterns. They can be both incorporated under the screen or around the outside of the screen. (Bellarby, 2009)

Since the concern about losses is reduced in this type of packs, very difficult formations can be successfully open hole gravel packed, which also included formations drilled with oil-based mud. (Bellarby, 2009)

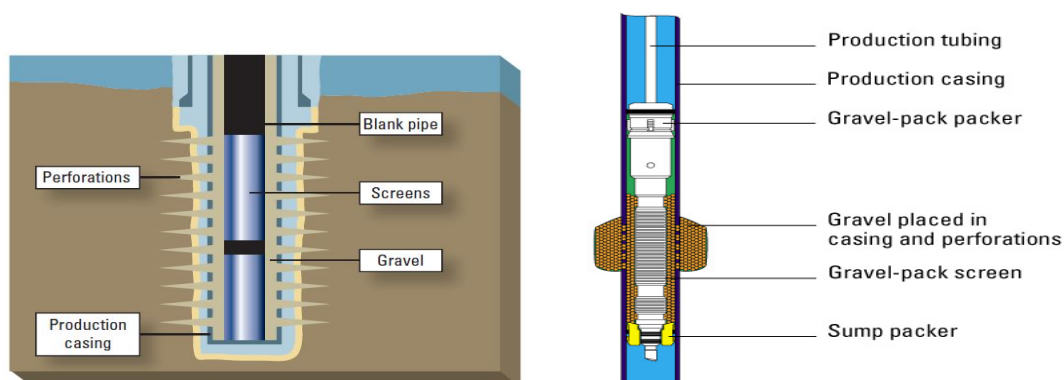
### 2.3.4 Cased Hole Gravel Packs and Frac Packs

Cased hole gravel packs are extensively used in the GoM and occasionally elsewhere. Their extension to frac packing is particularly much used. According to King et al. (2003) they provide some of the most reliable sand control completions. The disadvantage by using this is significant demands for logistics and time, as well as operational complexity. Due to the cost and complexity they are less attractive (but not impossible) for long reservoir sections. (Bellarby, 2009)

#### 2.3.4.1 Cased Hole Gravel Packing

There are two basic types of cased hole gravel packing; water packing and viscous slurry packing. They both use similar techniques to open hole gravel packing. This includes using similar tools, similar rates and they have the same desire to be able to squeeze and circulate. If the water pack is performed above fracture pressure it is called High-Rate Water Pack (HRWP). This should not be confused with a frac pack. Frac packing has the goal of fracturing the formation to stimulate the reservoir, while HRWP aim to aid in packing the perforations with gravel. (Bellarby, 2009)

In cased hole gravel packs it is desired to be able to squeeze and circulate. If pure circulation is done, it will lead to the perforations not being packed. To achieve squeezing, the BOP is closed to restrict the return flow. However, circulation will assist in getting the gravel to the toe of the interval for long intervals. Further, pre-packing the perforations prior to running the screens can aid in the placing of gravel into the perforations. Tubing conveyed guns in the hole can be used for pre-packing. Figure 2.20 shows an overview of cased hole gravel packing.



(a) Cased hole gravel pack. (Schlumberger, 2007)

(b) Typical system for cased hole gravel packing. (Rigzone, n.d., b)

**Figure 2.20:** Cased hole gravel pack overview.

HRWP produces a short and relatively thin fracture using water pumped above the fracturing pressure or the formation. Both screens and gravel is in place when pumping is carried out. (Schlumberger, 2007) Advantages, such as multiple fractures, minimal fracture growth (making risk of fracturing up into gas caps small) and low operational complexity, makes this a good option. (Bellarby, 2009)

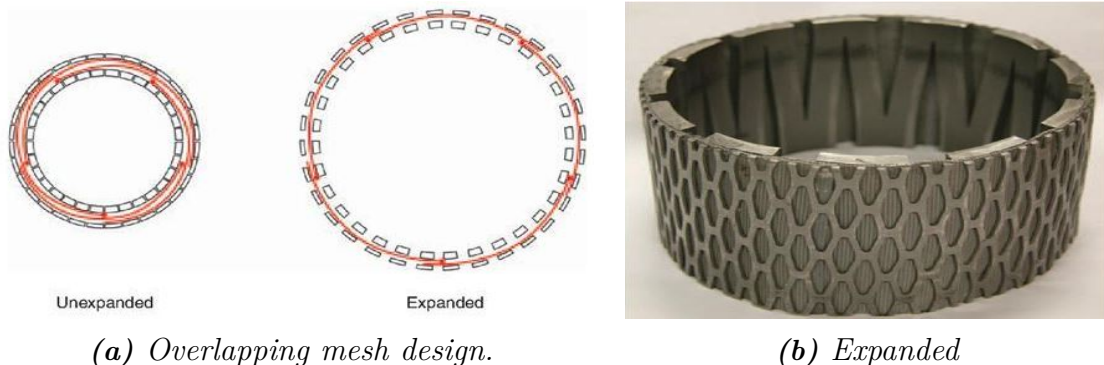
### 2.3.4.2 Frac Packing

Frac packing involves the simultaneous hydraulic fracturing of a reservoir and the placement of a gravel pack, and provides a viable option to conventional gravel packing. High-viscosity fluids are pumped at a pressure above fracturing pressure to create the fractures. Screens are in place at the time of pumping, with gravel placed outside the casing/screen annulus. The fractures helps to boost production rates, while the gravel pack prevents formations sand from being produced. This, in addition to the associated screens stopping the gravel from entering the produced fluid, combines the production improvement from hydraulic fracturing with the sand control provided by gravel packing. (Schlumberger, 2007) Frac packs provide high-conductivity channels that penetrate deeply into the formation, leaving the gravel near the wellbore and in the perforations clean and undamaged. Frac-pack methods may bring skin values down to zero. More than 65% of sand control completions in the GoM now use frac-pack systems. (Schlumberger, 2007)

### 2.3.5 Expandable Screens

Expandable screens are relatively new in the industry. They avoid the open annulus that historically caused failure to many standalone screen completions. As these have similar performance to open hole gravel packs, and are additionally easier and cheaper to install, they are slowly displacing open hole and cased hole gravel packs in some areas. New techniques are evolving where expandable screens may be used with expandable solid liners. This offers the opportunity for zonal isolation in a much simpler way than with the alternatives requiring pumping of gravel. (Bellarby, 2009)

There are two types of expandable screen in use today; one using overlapping woven sheets, the other uses a screen that can be expanded itself. In the first mentioned the mesh itself does not expand, only the sheets move past each other as the screen expands. To do this, a metal base pipe and an outer shroud protects the mesh, which are both expandable. “Hinges” at the ends of the slots will plastically deform. This means that the pipe does not yield. (Bellarby, 2009) Figure 2.21 shows how the overlapped mesh design works, and an expanded screen.

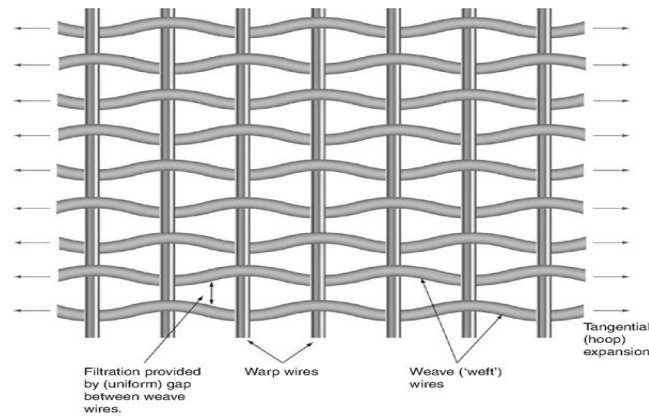


(a) *Overlapping mesh design.*

(b) *Expanded*

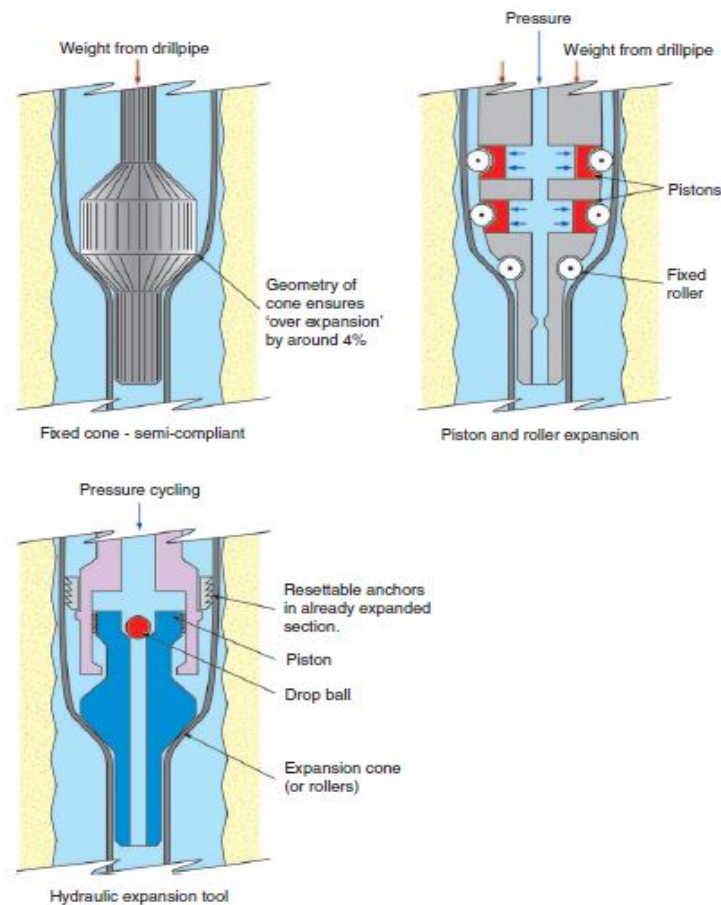
**Figure 2.21:** *Expandable screens (Bellarby, 2009)*

In the other approach, where the screen itself expands, woven screens are used. Figure 2.22 shows a woven mesh used for this. The weave (“weft”) wires expand tangentially whilst the *warp wires* do not expand. Although expanded, the gap is unchanged, and provide filtration of sand. The arrangement shown here is for clarity, and would be prone to variable gaps between the wires. Multiple layers are typically used. (Bellarby, 2009)



**Figure 2.22:** Woven mesh for expandable screens. (Bellarby, 2009)

Figure 2.23 shows different expansion methods used. They will not be discussed in further detail.



**Figure 2.23:** Expansion methods. (Bellarby, 2009)

## 2.4 Completions for Special Applications

### 2.4.1 HPHT Completions

High Pressure High Temperature (HPHT) wells are defined as wells with pressure higher than 10,000 psia (689 bara) and with temperatures higher than 300 °F (149 °C). (McSpadden and Glover, 2008) These high pressures and temperatures are usually connected to deep wells, but can however be generated from isolated “rafts” of sediments. In these HPHT wells, wet gas and condensates predominate. (Bellarby, 2009)

Combining the high stress in HPHT wells with high drawdowns and depletion, sand production can be an issue. Sand control is discussed in Section 2.3. It is although worth noting a few extra demanding properties of sand control in HPHT wells (Maldonado et al., 2005):

- High erosion risk due to gassy, high-velocity fluids.
- The application of frac packs may be restricted by high formation stresses due to high surface pressures.
- Gravel pack fluids are challenging.
- May require complex geomechanical models due to rock movement dominated by plastic deformation.
- Exotic brines (with compatibility issues) or high solids loadings (screen plugging issues) are often used in HPHT muds.

For HPHT wells that need stimulation, this is mostly left until productivity declines due to depletion. This brings surface pressures to more manageable levels. (Bellarby, 2009)

When it comes to material selection for HPHT wells, the demands are high for tubulars. During a shut-in scenario (3.2.4 on page 42) the high pressures and gassy fluids create high burst loads, which set the requirements for high-strength tubulars. The depth combined with these gassy fluids may also create high collapse tubing loads above the packer. (Bellarby, 2009)

### 2.4.2 Multilateral Completions

A multilateral completion makes it possible to drill and complete multiple wells within a single wellbore. Such well systems combine the ability to reach multiple target zones with the advantages of horizontal-drilling techniques. Depending on which design is used, different target zones can be produced independently or simultaneously. (PetroWiki SPE, 2006, a)

The Technology Advancement of MultiLaterals (TAML) system is used to categorise the various degrees of multilateral systems. This is based on the amount and type of support provided at the lateral junction. The system has six levels; complexity and cost increases with increasing level. The different levels will be described in short in the following paragraphs. (PetroWiki SPE, 2006, a)

### 2.4.2.1 TAML Level 1

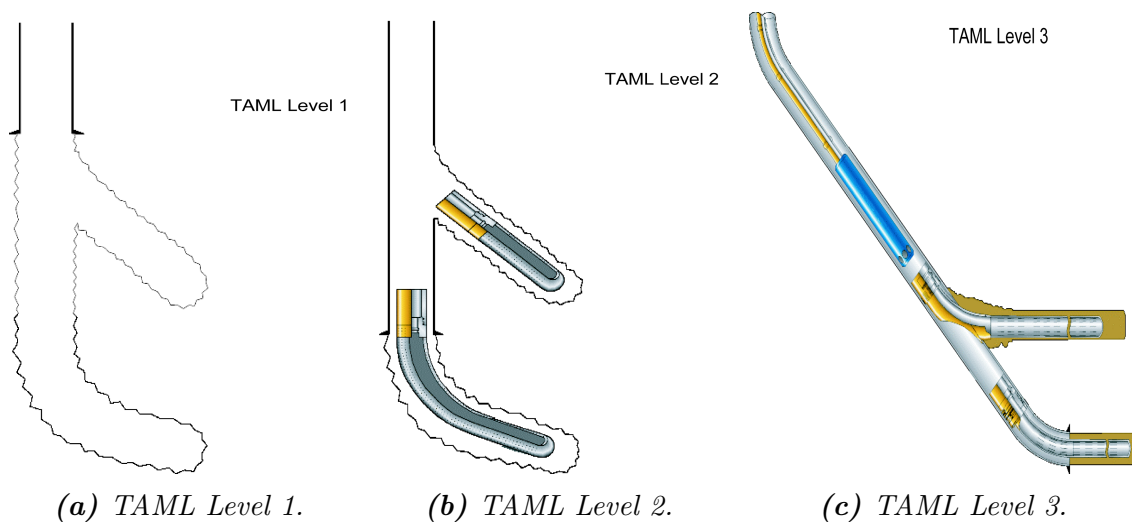
This is the most fundamental multilateral system. It consists of an openhole main bore with multiple drainage legs, leaving the junction with no mechanical support or hydraulic isolation. A slotted liner may be used in the lateral or the main bore to help keep the hole open during production. It is not possible with zonal isolation or selective control of production with this type of lateral system. Figure 2.24a shows a Level 1 lateral. (PetroWiki SPE, 2006, a)

### 2.4.2.2 TAML Level 2

As seen in Figure 2.24b, Level 2 is similar to Level 1. The exception is that the laterals are drilled off of a cased and cemented main bore. This provides a means of hydraulic isolation and minimizes the chance of borehole collapse. There is no mechanical support of the lateral junction; however, as with Level 1, a slotted liner can be run into the lateral to maintain borehole stability. (PetroWiki SPE, 2006, a)

### 2.4.2.3 TAML Level 3

Here, the main bore is cased and cemented with an openhole lateral. Figure 2.24c shows an example of this. The main difference in this design is, however, the lateral is completed with a slotted liner or screen which is anchored back into the main bore. This enables mechanical support of the lateral junction. The disadvantage with this system is that zonal isolation is not possible. (PetroWiki SPE, 2006, a)



**Figure 2.24:** TAML Level 1, 2 and 3. (PetroWiki SPE, 2006, a)

### 2.4.2.4 TAML Level 4

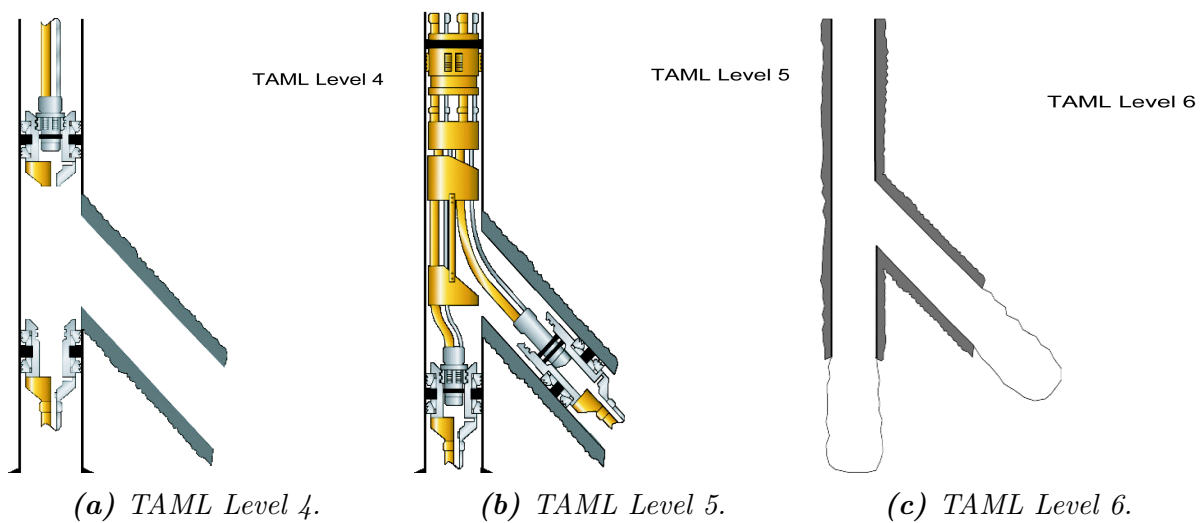
In level 4, the main bore and lateral are both cased and cemented. The mechanical support in the lateral is therefore excellent, although pressure integrity at the junction is not gained from the cement. Packers can be installed above and below the junction in the main bore to achieve zonal isolation. Coiled tubing intervention is possible both in the main bore and lateral. Figure 2.25a shows a sketch of a level 4 system. (PetroWiki SPE, 2006, a)

### 2.4.2.5 TAML Level 5

As seen in Figure 2.25b, level 5 is similar to level 4 in that they are both cased and cemented in the main bore and lateral. However, in level 5, tubing strings and packers are used to isolate the junction and achieve pressure integrity. A dual-string isolation packer is located above the junction, enabling independent production if needed. (PetroWiki SPE, 2006, a)

### 2.4.2.6 TAML Level 6

Level 6 wells use casing to seal the junction. The junction is premanufactured, either reforming the junction downhole, or drilling two separate wells out of a single main bore and assembling the premanufactured junction downhole. Figure 2.25c shows an example of this. (PetroWiki SPE, 2006, a)



**Figure 2.25:** TAML Level 4, 5 and 6. (PetroWiki SPE, 2006, a)

## 2.4.3 Dual Completions

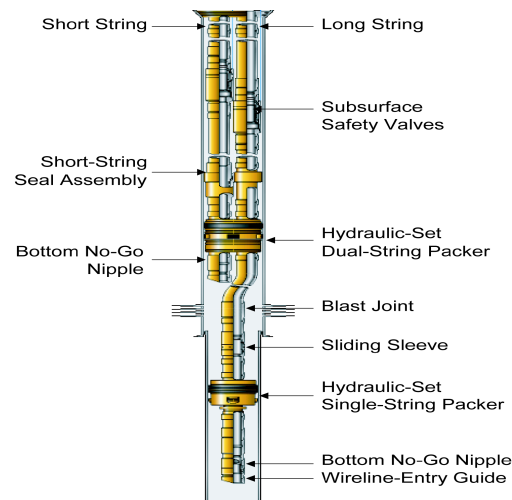
Dual completions are used where independent production or injection is required. They are most common in stacked reservoir sequences, often in shallow water wells with low to moderate rate. Independent production or injection can be needed for a number of reasons (Bellarby, 2009):

- Different pressure regimes
- Incompatible fluids (e.g. scales)
- Regulatory requirements
- Multipurpose wells

Figure 2.26 shows a typical dual completion. The typical setup of a dual completion are with  $3\frac{1}{2}$  " or  $2\frac{7}{8}$  " tubing inside  $9\frac{5}{8}$  " casing. (Bellarby, 2009)

Dual completion is a complex process. The installation steps are complex, sand control integration is difficult and the upper interval is difficult to perforate.



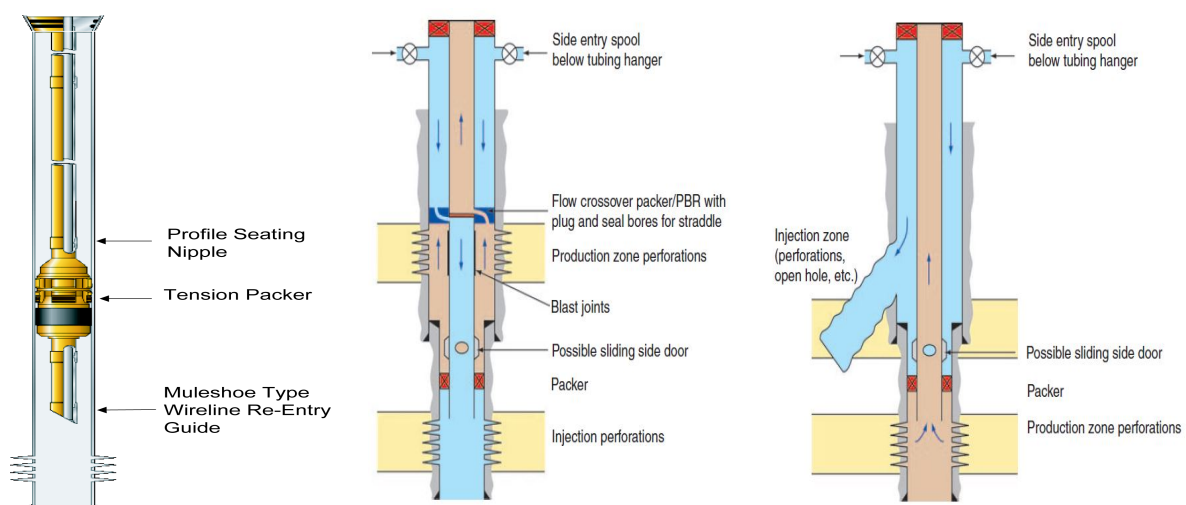


**Figure 2.26:** Parallel-string dual-zone completion. (PetroWiki SPE, 2006, a)

### 2.4.4 Multipurpose Completions

Using this type of completion creates the opportunity for separate flow streams without a dual completion system. An example is injection of water down the annulus, while simultaneously producing up the tubing. Several types exist; single string completion with packer or with crossover packer, and multipurpose multilateral completions. (PetroWiki SPE, 2006, a)

The single string completion with packer is the simplest of the multipurpose systems. Here, the flows goes through the wellhead valves and through perforations above a single packer. In the second type, the flow crossover packer is used to divert flow between the upper tubing and lower annulus and the upper annulus and lower tubing, as shown in Figure 2.27b. Figure 2.27c shows a multipurpose, multilateral system. These are quite complex, although they can be made simpler if giving up injection interval intervention. (PetroWiki SPE, 2006, a)



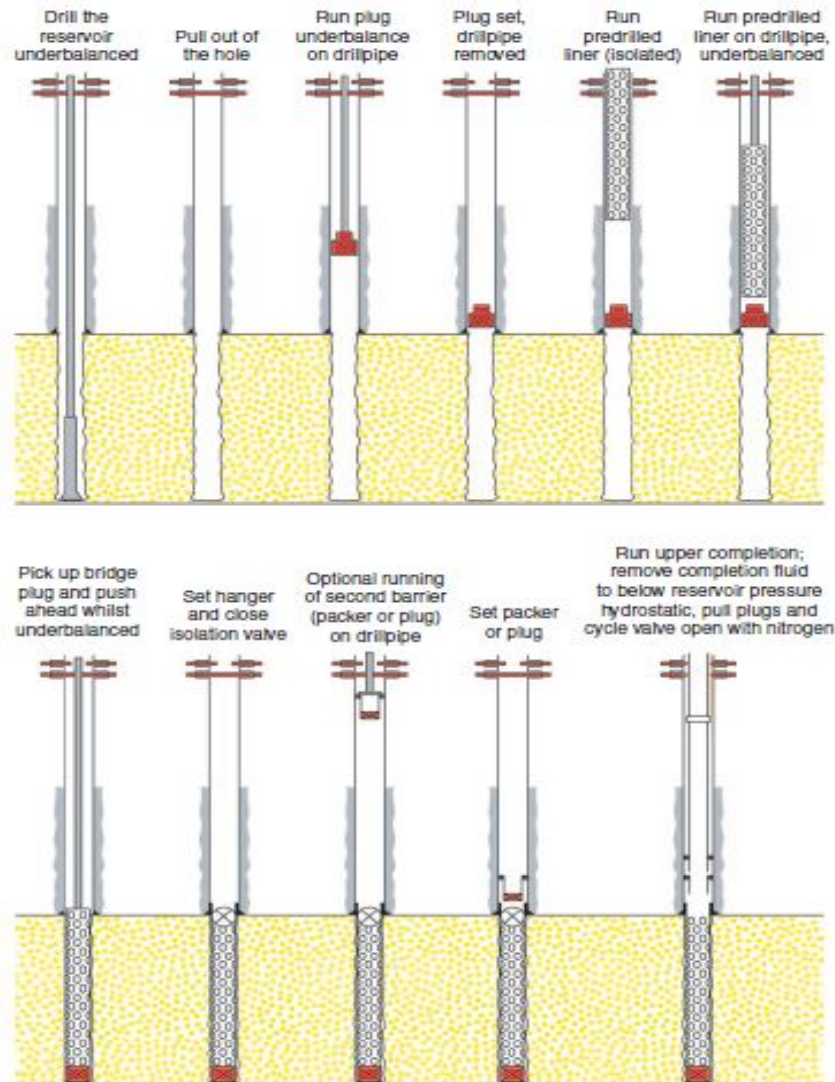
**(a)** With single packer. **(b)** With a flow crossover packer. **(c)** Multilateral multipurpose completion. (PetroWiki SPE, 2006, a) (Bellarby, 2009)

**Figure 2.27:** Multipurpose completions.

### 2.4.5 Underbalance Completions and Through Tubing Drilling

Underbalance completions are used if the reservoir is drilled underbalanced. This is done with the main intention of reducing formation damage. When using this type of completion, a barefoot solution, or one with a pre-drilled liner is chosen. Gravel packing is not possible. (Bellarby, 2009)

The general way of doing this is by using surface pressure while deploying the reservoir completion. The reservoir completion is hydraulically isolated by a valve or plug when the the upper completion is run (Figure 2.28).



**Figure 2.28:** Completing an underbalance drilled well. (Bellarby, 2009)

Systems to deploy screens or pre-drilled liners exist - but, such systems are rarely used due to availability issues of large enough sizes. Another technique, often used for through tubing sidetracks, is done by installing the completion prior to drilling the reservoir section. (Bellarby, 2009) This is also well suited to multilaterals. (Venhaus et al., 2008)

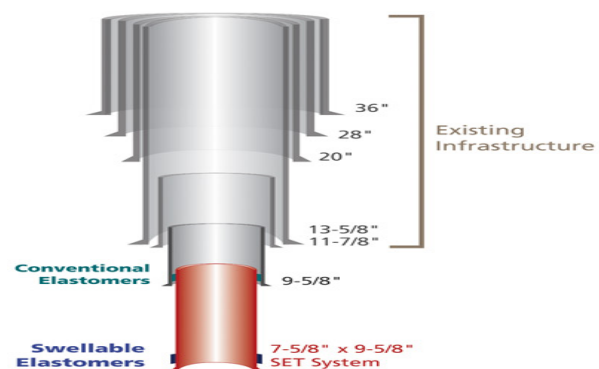
## 2.4.6 Coiled Tubing and Insert Completions

This technique is used in small-diameter applications to reduce operation time and the requirement for a conventional rig. These completions could be run underbalanced, however, they are usually run in conventional completion fluids. (Bellarby, 2009)

It can be done either with the same OD for the completion equipment as the coiled tubing, or it can be conventional size and connected to the coil as the completion is run. An issue with coiled tubing completions is that they do not have 13Cr metallurgy. Meaning, they will quickly corrode if exposed to environments containing CO<sub>2</sub>. (Bellarby, 2009)

## 2.4.7 Expandable tubulars

In deepwater environments hole size at TD can be challenging. Problems such as salt and sub-salt zones, narrow pressure window and over-pressured and depleted sands are usually present. Expandable technology has developed as an answer to the restrains given by inner diameter when sidetracking out of an existing wellbore. Many examples exist where the ID has been a challenge at TD. If for instance the 9<sup>5</sup>/<sub>8</sub>" casing is set high, a 7<sup>5</sup>/<sub>8</sub>" X 9<sup>5</sup>/<sub>8</sub>" expandable system can be installed to cope with this (Figure 2.29). (Rigzone, n.d., c)



**Figure 2.29:** Typical deepwater setup in the GoM, below 20,000 ft. (Rigzone, n.d., c)

## 2.4.8 Lifting and Well Treatment

### 2.4.8.1 Hydraulic Fracturing

Basic techniques of fracturing is covered in this section. Aspects such as fluid selection, planning and pumping operations are mentioned, not discussed in depth.

Fracturing has mainly been used for onshore wells, but in the past years the technique has been used on some offshore wells. Onshore, as much as 50-60 % of all wells completed in North America are fracture stimulated. (Bellarby, 2009)

The basic idea behind fracturing is pumping a fluid at a high enough pressure down the wellbore. After this, solids is used to force the fracture open to maintain conductivity. The tensile strength of the rock has to be overcome to open a fracture. The pressure will overcome the minimum stress, and the fracture will propagate perpendicular to the minimum stress. Fracturing is done to provide an easier route for fluids to flow into the wellbore.(Bellarby, 2009) The different stresses will not be discussed in this thesis.

The stimulation process can be done by using coiled tubing, through a permanent completion or a temporary string (frac string). Due to high pressures and cold fluids, tubing stress analysis is critical for all methods. (Bellarby, 2009)

### 2.4.8.2 Acid Fracturing

Acid fracturing use much of the same theory as for hydraulic fracturing, especially regarding fracture initiation and propagation. Acids dissolve acid-soluble rocks, such as limestones and chalks, to enhance productivity. Hydrochloric acid is most common, which reacts with the calcium carbonate found in limestones and chalks. The reaction goes as follows:



Several factors needs to be considered when choosing acid systems and additives; corrosion inhibitors, emulsion and sludge prevention, iron precipitates, friction reducers and surfactants are some of them. (Bellarby, 2009)

When the acid reacts with the fracture, it etches uneven channels along the fracture face. The goal is to limit leak-off and hence promote acid penetration. Acid treatments do not use solids, which is an advantage over hydraulic fracturing.

### 2.4.8.3 Artificial Lift

Artificial lift is used to increase the flow rate by adding energy to the flow stream within the completion. A short description will be given below of the different techniques available.

#### Gas Lift

This is the only approach of artificial lift that does not require a downhole pump. It is widely used offshore and on subsea wells. It provides a flexible approach to artificial lift and is well suited for wells with uncertainties to productivity or pressures. However, it does not help in low bottom hole pressures, unlike a pump, and is not as efficient. (Bellarby, 2009) This is a wide topic, but will not be discussed in more detail in this thesis.

#### Pumps

Electrical Submersible Pumps (ESPs): These are much used where high rates are required. However, they have high failure rates due to the hostile downhole environment and the use of electrical and moving part components. (Bellarby, 2009)

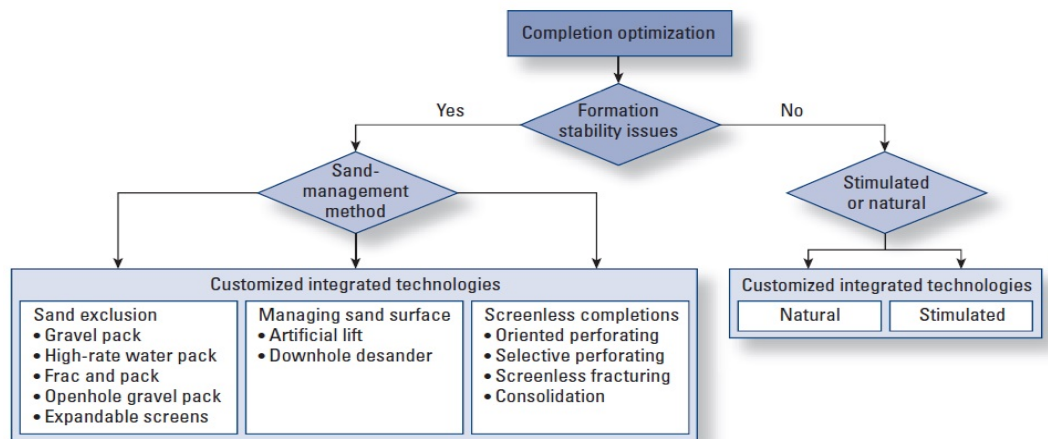
Turbine-Driven Submersible Pumps: This type of pumps operate in a similar way of ESPs, by using multi-stage centrifugal pumps, however, with a downhole turbine to power the pump. They do not need electrical connections or downhole electronics. The disadvantage by using this type is that it needs a power fluid to be pumped downhole. (Bellarby, 2009)

Jet Pumps: This is the only approach to artificial lift that do not require downhole moving parts. It is typically used in low to moderate-rate wells. They are compact and reliable and ideal for remote areas due to the possibility of installing it by wireline. (Bellarby, 2009)

Progressive Cavity Pumps: This is a positive displacement pump, unlike jet pumps, ESPs and HSPs. They are mostly used in moderate-rate wells onshore. (Bellarby, 2009)

## 2.5 Optimal Completion in Theory

Optimizing deepwater wells involves such an extensive process, including a wide range of decisions, that it can not be summed up into one simple recommendation. Formations, challenges, equipment access, weather/environment, all impose great varieties from place to place. All completions must therefore be evaluated individually. However, there are some general ideas/principles that seems to be valid for a a wide range of cases. Some of these will be presented in the following section. Figure 2.30 shows a simple completion optimization scheme. Figure E.2 on page A-53 shows a more complex scheme.



*Figure 2.30: Completion options. (Schlumberger, 2007)*

### 2.5.1 Common Decisions

If multiples pay zones are encountered, analyses and economic evaluations are needed to determine whether the zones should be completed and produced simultaneously or independently. From a mechanical point of view, it is better to produce from the lowest zone first (to its economic limit) and then recomplete in the upper zone. However, seen from an economic perspective, the upper zone is often selected as the initial completion. To achieve this, a sliding sleeve is often used. The main disadvantage by producing the upper zone first is the possibility of failure in the isolation devices at a later stage. (Dyson et al., 1999)

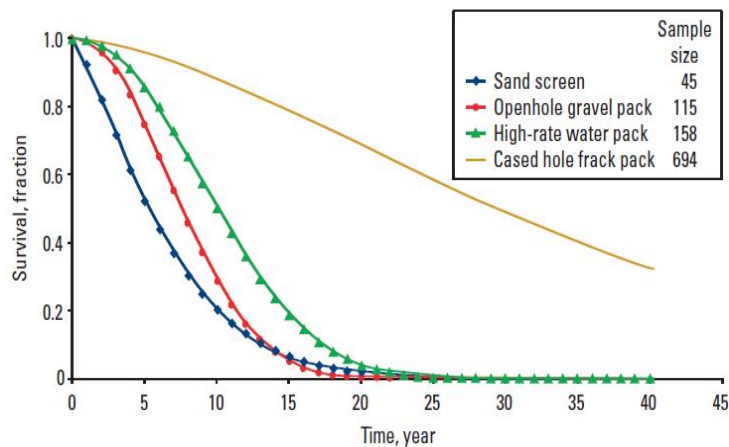
### 2.5.2 General recommendations

The choice of completion method is highly based on the competence of the formations encountered. Non-sand control completions are best for competent formations, due to fewer components, little risk and low installation cost. If the formations is poorly consolidated, sand control are required. They are more exposed to failure and intervention is expensive. If a fluid interface such as an oil-water contact is present, horizontal completions are best suited. (Dyson et al., 1999)

Multiple zone completions require more equipment than single zone completions. This includes packers, gravel packs, etc. The chance of failure decreases for sliding sleeves if not relied upon for upper sands prior to lower sands. (Dyson et al., 1999)

Due to the characteristics of deep waters along with the challenges, slurry properties such as density and hydration characteristics must be optimized for the well parameters. Low fracture gradient formations can for instance not use a high-density slurry that has strong hydration characteristics due to the high cement content. In addition, a fast setting cement slurry would increase placement/mixing pumping difficulties, although it could reduce the wait on cement time. Due to the increased problems, it may not offset the gain in the reduced Waiting on Cement (WOC) time. (Ravi et al., 1999) Optimization of the completion process is therefore crucial for the success of the well completion.

Properly executed cased hole frac packing appears to be more stable and long-lasting solution for sand control than openhole gravel packing, sand screens, or high-rate water-packing techniques (Figure 2.31).



**Figure 2.31:** Completion life comparison for different sand control options. (Schlumberger, 2007)

Frac packs require more complex fluids, larger volumes and higher pump rates than cases hole gravel packs. However, such equipment is easily available in areas such as the GoM. The additional cost then becomes small in comparison to the benefit. Frac packs are therefore used as the primary cased hole sand control technique in these areas. (Furgier et al., 2007) Frac packs cannot be used in reservoir with a gas cap and often not in reservoirs with no effective barrier between the reservoir zones and the underlying aquifers. (Schlumberger, 2007)

The high pressure and temperature in deepwater HPHT wells creates extreme loads in the well. New, stronger casings may therefore be needed. In the following, a study of a deepwater well has been done. Casing configuration and casing strength has been simulated for different loads, and tried optimized. Some new casing material specifications have been found needed.

# Chapter 3

## Stress Analysis

### 3.1 Stress Analysis

In this chapter some background theory on stress analysis is presented. Additional equations and theory are presented in Appendix A. In addition, the project description and some general specifications are presented at the end.

#### 3.1.1 Purpose of Stress Analysis

Most completion designs require a well and tubing stress analysis. Especially when moving into deeper waters and hotter reservoirs, the requirements increases. When simulating the different load cases, the goal is to find the worst case so that the design is safe for the life of the well. The basics for a casing design is assessment of burst, collapse and tensional loads on the string. In this thesis, reasons for doing such a study include (Bellarby, 2009):

- Defining the grade and weight of the completion;
- Ensuring that the selected casings will withstand all projected loads for the life of the well;
- Ensuring that the casings can be run into the well;
- Defining loads for casing stress analysis.

#### 3.1.2 Stress, Strain and Grades

Loads experienced in the well may come from many sources including temperature, pressure and pipe weight. These loads can act axially (compression and tension) or radially (burst and collapse). An understanding of these loads and how the metals behave under the loads is fundamental when designing a well. Stress quantifies the loads, and is defined as force per unit area:

$$\sigma = F/A_x \quad (3.1)$$

Where:

$\sigma$  = Stress

$F$  = Force

$A_x$  = Unit area

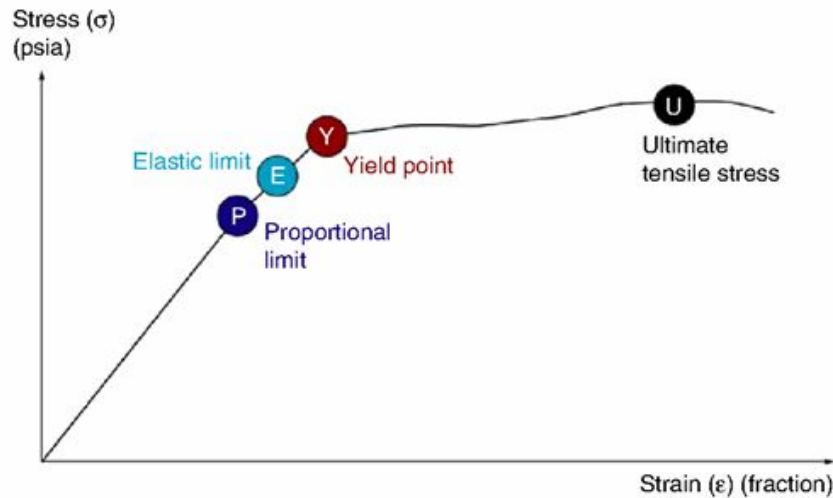
Casings subjected to stress will elongate or stretch. Strain describes this and is dimensionless. It is defined as the fractional length:

$$\varepsilon = \Delta L/L \quad (3.2)$$

Where:

$$\begin{aligned}\varepsilon &= \text{Strain} \\ \Delta L &= \text{Length change} \\ L &= \text{Length}\end{aligned}$$

Figure 3.1 shows a typical stress-strain relationship. Initially, a linear relationship exist between stress and strain. The slope of this straight line is called the *modulus of elasticity* ( $E$ ) or Young's modulus. (Bellarby, 2009)



**Figure 3.1:** *Stress-strain relationship.* (Bellarby, 2009)

Casing is graded on the basis of its minimum yield strength. The API<sup>1</sup> defines the yield strength as “the minimum stress required to elongate the pipe by 0.5 % for all grades up to T95, 0.6 % for grade P110 and 0.65 % for grade Q125.” (Bellarby, 2009) Table E.2 in Appendix X shows API grades and strengths.

### 3.1.3 Axial Loads

Axial load are loads along the length of the casing. They can be tensile (positive forces) or compressive (negative). Factors such as temperature, pressure and the weight of the casing affect these loads. (Bellarby, 2009) The theory behind these loads is extensive and will only be discussed briefly in this thesis.

The axial strength is defined as the “maximum axial force before exceeding the yield stress” (Bellarby, 2009):

$$F_{a,max} = A_x \cdot Y_p \quad (3.3)$$

Where:

$$\begin{aligned}F_{a,max} &= \text{Axial strength} \\ A_x &= \text{Pipe cross-sectional area (in.}^2\text{)} \\ Y_p &= \text{Yield stress (psi)}\end{aligned}$$

<sup>1</sup>The American Petroleum Institute



The expansion of metal when it is heated can be described as in Equation 3.4. Heating will cause a compressive force if the casing is fixed at both ends, and a tensile force if cooled. (Bellarby, 2009) These forces are generally caused by production of hot fluids, and are thus very applicable for deepwater wells.

$$\Delta L_T = C_T \cdot \Delta T \cdot L \quad (3.4)$$

Where:

$\Delta L_T$  = Expansion

$C_T$  = Coefficient of thermal expansion deg  $F^{-1}$

$\Delta T$  = Average change in temperature deg  $F$

$L$  = Length

Additional loads defined as axial loads include weight of casing, piston forces (buoyancy, expansion devices, etc), ballooning, fluid drag, bending stresses and buckling. (Bellarby, 2009) Typically when lowering the casing through tight spots, stick-slip effects or abrupt changes in the running speed can induce tensional shock loads. (Aadnøy, 2010)

The sum of the aforementioned forces makes up the total axial force. Most software divides the casing into small lengths before computing the axial loads. Whether the casing is free to move or not makes a difference for the calculations. If it is free to move, the force applied only affects the area above where it is applied. If not, the casing is stretched until it is back to its starting position. (Bellarby, 2009)

### 3.1.4 Burst

When the mechanical strength of the pipe is exceeded by difference between the internal and external pressures, the pipe will have a tendency to burst. This is a tensile failure, which results in a rupture along the axis of the pipe. (Aadnøy, 2010)

Barlow's equation (Equation 3.5) describes the burst rating. The wall thickness tolerance for API pipe is 0.875 (12.5% reduction). In comparison to collapse and axial failures, burst failures only requires a failure of a very small piece of the casing. This means the burst rating is impacted by anything that affects the minimum wall thickness. (Bellarby, 2009)

$$p_b = Tol \left( \frac{2 \cdot Y_p \cdot t}{D} \right) \quad (3.5)$$

Where:

$p_b$  = Burst rating

$Tol$  = Wall thickness tolerance correction (fraction)

$D$  = Tubing outside diameter (in.)

$t$  = Nominal tubing thickness (in.)

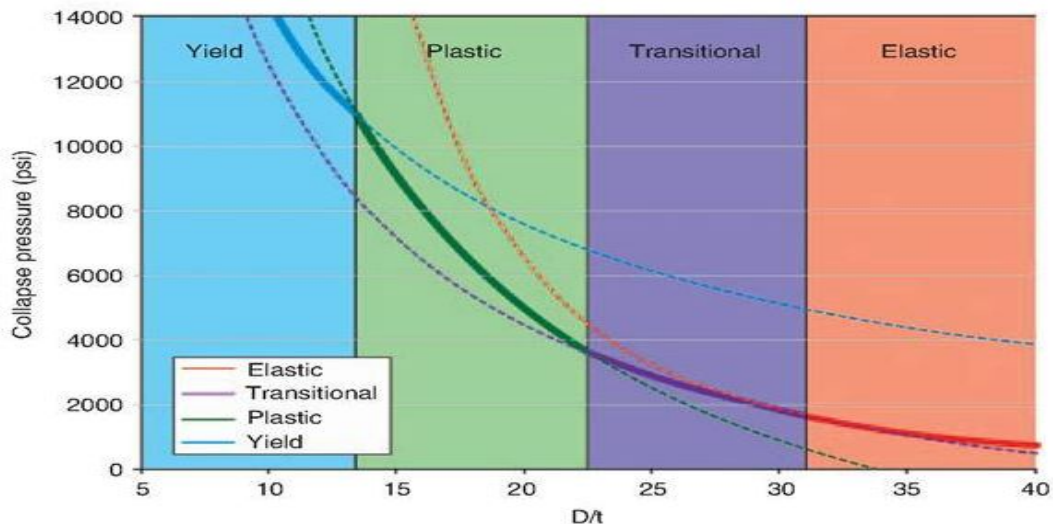
$Y_p$  = Yield strength (psi)

There are several situations that may result in a bursted pipe. Many of these situations have similar pressure pictures. Thus, some main categories can be established from a design point of view. These are discussed more in detail in Section 3.2.4 on page 42 (Aadnøy, 2010):

1. *Gas-filled casing.*
2. *Leaking tubing criterion.*
3. *Maximum gas kick.*

### 3.1.5 Collapse

The collapse rating is a more complex issue than the burst rating. Casing diameter and thickness, as well as properties such as pipe ovality (harder to define) affect the collapse rating. Four collapse modes are defined in the API Bulletin 5C3 (1999); elastic, transitional, plastic and yield strength. Each different mode have an associated formula. All of them are empirical in origin. The slenderness ratio (OD-to-thickness (D/t) ratio) defines the selection of the appropriate mode. Each mode has an associated formula. The collapse equations are presented in Appendix A. Different values for collapse modes are shown in Table A.1. (Bellarby, 2009) Figure 3.2 shows collapse pressure as a function of slenderness ratio.



**Figure 3.2:** Collapse pressure as a function of slenderness - L80 tubing. (Bellarby, 2009)

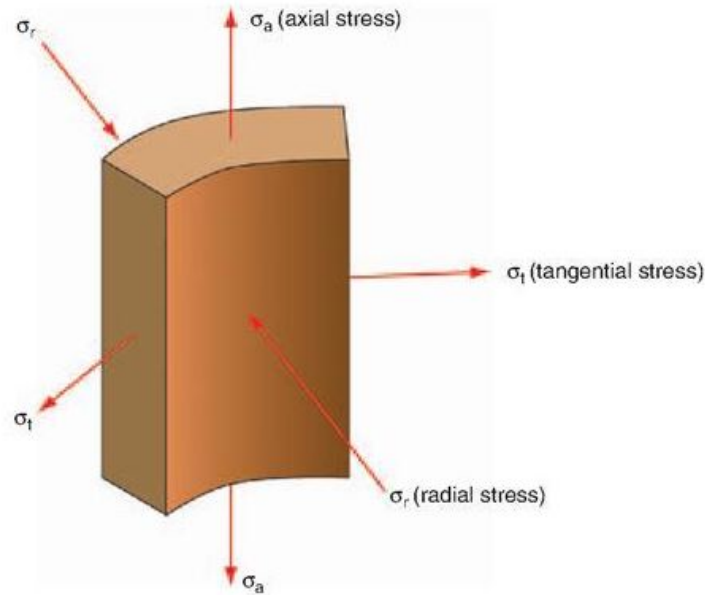
The main issue with collapse of pipe is that equipment may no longer fit through the inside of the pipe. This occurs when the external pressure exceeds the internal pressure. Pore pressure, drilling fluid or temperature expansion creates the external pressure, while the hydrostatic pressure exerted by a mud or saltwater column defines the internal pressure. During a collapse, the casing is deformed, and thus collapse is a geometric failure, not a material failure. (Aadnøy, 2010)

There are several situations that may result in a collapsed pipe. However, the following two criteria incorporates most of them. These are discussed more in detail in Section 3.2.4 on page 42 (Aadnøy, 2010):

1. *Mud losses to a thief zone.*
2. *Collapse during cementing.*

### 3.1.6 Triaxial Analysis

Looking at pressure and axial loads in isolation is insufficient for a rigorous design. Tension will reduce the pipe diameter, compression will balloon the casing, as will applying internal pressure. Thus, the combination of tension/compression and external/internal pressure will generate higher stresses than they would alone. Mathematically, this is expressed in terms of axial stress ( $\sigma_a$ ), radial stress ( $\sigma_r$ ) and tangential stress ( $\sigma_t$ ), and combined, they are called the *triaxial* stress. (Bellarby, 2009) Equations for Triaxial stress can be found in Appendix A. Figure 3.3 shows the stress components of a triaxial analysis.



**Figure 3.3:** *Stress components of triaxial analysis. (Bellarby, 2009)*

The most used criterion for yielding is the Von Mises (VME) yield condition (Huber-Hencky-Mises). This is based on the maximum distortion energy theory. Yielding will occur if the VME stress exceeds the yield stress. The VME stress is not a vector addition of the three stresses, but a combination of them. (Bellarby, 2009) This is a complex and extensive subject. Further discussion would therefore be outside the thesis objective. For deeper theory on the subject, Bellarby (2009) includes an informative and thorough section on this.

### 3.1.7 Temperature Effects

Increased temperature causes the pipe strength to decrease. As the temperature in deep, high pressure wells are quite high, corrections have to be applied. A strength-depth curve is therefore made for these wells. If bottomhole temperature exceeds 100 °C a derating of the strength is required. This should follow the manufacturer's recommendations. (Aadnøy, 2010)

An additional problem resulting from temperature change is annular pressure build-up. This is discussed further in Section 3.2.4.13 on page 46.

### 3.1.8 Safety Factors and Design Factors

When the potential loads are analysed, the acceptability of the design can be evaluated. This can be done by using safety factors, which compares the loads with the rating of the pipe. A Safety Factor (SF) greater than 1 represent a rating that is greater than the load. Safety factors can be calculated for each of the mechanisms (burst, collapse, etc.) (Bellarby, 2009):

$$SF = \frac{Rating}{Load} \quad (3.6)$$

SFs greater than 1 means that the casing should remain intact. Due to uncertainties in calculations, definition of loads, etc., the applied minimum safety factors are greater than one. These factors are called design factors, and can be seen in Table 3.1 (NORSOK values). They usually vary from casing to tubing. (Bellarby, 2009)

**Table 3.1:** *NORSOK completion design factors. (Bellarby, 2009)*

Failure Mode	Design Factor
Burst	1.1
Collapse	1.1
Axial (tension and compression)	1.3
Triaxial	1.25

## 3.2 Design Basis

As this study was conducted on a specific field, it may differ some from other field in the GoM. It was however tried to achieve as general conclusions as possible. For this specific well, the geologists have deemed the risk of encountering gas as very little. In addition, gas lift is though of as an interesting scenario. The main conclusions are therefore based on no expected gas before the reservoir section and gas lift plans. Three sensitivities were done to include the effects when hydrocarbons cannot be ruled out. The following scenarios were therefore considered: (A) no hydrocarbons expected before reservoir section, (B) hydrocarbons can not be excluded before 13 5/8" is set, (C) no hydrocarbons expected and planned for gas lift (main case), and (D) hydrocarbons can not be excluded before 13 5/8" is set and planned for gas lift.

In the chosen well, a 1,000 m salt formation is present. This was included in all the simulations. A sensitivity study was made for a case without a salt formation. Table B.4 and Figure B.2 show the setting depths. The proposed well was set up using a 18" liner, a 16" liner, 13 5/8" casing. A 9 7/8" liner with a tieback was set at top reservoir. The salt formation is present in the 16" section. No design calculations were performed on the 36 in conductor as such a study has own requirements beyond the scope of this thesis.

The resulting well design from the WellCat study was used for the drillability study. The final design can be seen in Table 4.1. Drilling, liner running and cementing was investigated. Input data to WellPlan can be found in Appendix B.3. The simulations were only conducted for the reservoir section, as the drillability study was not part of the

main objective in this thesis. Some comments and discussion are however made on some of the other sections as well.

Expectations for the simulations were that ECD and cementing would be the most challenging for the chosen design. Especially cementing the 9 7/8" liner and the 13 5/8" casing. This was based on the high loads requiring thick walls for some of the pipes. This will create small clearances, and thus increased pressure losses. In addition, the high wall thickness results in heavier pipe. This, along with the deep well, may create problems with rig capacity.

### 3.2.1 External Pressure Profile - Burst

To create worst case scenarios for the burst loads the external pressure profile was made as low as possible for each load case. To do this, some general actions were included. First, pore pressure in open hole was activated for all burst loads. This prevents WellCat from using the cement density for cement in OH (not within prior shoe), thus yielding a worse case burst load.

Mud weight above TOC was set to the fluid used when drilling the section. Mud weight below TOC was set to the mix-water density of cement, 1.03sg. This assumes a hydrostatic column of the mix-water in cemented intervals. This is representative of the mix-water contained in the pore space of the permeable hydrated cement, meaning that the cement job is "bad", thus giving a lower external pressure than the cement density would.

For all liners the above/below prior shoe profile was used. The external pressure profile is then based on the Equivalent Mud Weight (EMW) corresponding to the minimum pore pressure gradient in the open hole interval and the cement mix-water density. Below the prior shoe, the external pressure profile was based on  $EMW_{min}$ .

### 3.2.2 External Pressure Profile - Collapse

To create worst case scenarios for the collapse loads the external pressure profile was made as high as possible for each load case. This was done by setting the mud weight used when drilling the respective section as the MW both above and below TOC. Pore pressure in open hole was not enabled. This creates the highest external pressure profile, and thus the worst collapse scenario.

#### 3.2.2.1 Cementing - Load Case Setup

The *cementing* load case were identical for all sections and thus described in general in the following section. It was added as a Green cement test in WellCat, with 0 bar pump pressure. This is a workaround, as WellCat do not have a cementing case by default. Using the green cement test with no pump pressure the software interprets it as the effect of wet cement. The load case is equal to the initial conditions. For the external pressure drilling fluid density was used both above and below TOC. This gives the most conservative collapse load.

### 3.2.3 Axial Load Case Setups

The axial load cases were similar for all sections, and will be presented in general in the following section.

The *running in hole* load case was specified with a running speed of 1 m/s. When specifying a non-zero average running speed, the effect of the pipe stopping abruptly is included in the axial profile. This occurs if the slips close while the pipe is moving, or the pipe hits an obstruction. The fluid was defined as the fluid present when running the string.

The *overpull* load case was specified with a 91 tons (200 kips) overpull force. This is a Statoil regulations for GoM operations. For the Norwegian regulations the requirement is 50 tons.

*Pre-cement static load* and *post-cement static load* was also included. These were added as a overpull and a green cement test, respectively. This is a workaround in WellCat, as they do not have a default load case. The pre-cement static load was specified with the same fluid used for drilling and a 0 tons overpull. The post-cement static load was defined with 0 bar pump pressure.

### 3.2.4 Load Cases

This section presents the main load cases evaluated in this thesis. It is important to have a good understanding of the loads experienced in the well to get as close as possible to the real life loads experienced during the life of the well. A brief discussion will be presented on which parameters that should be incorporated into each load and how to ensure that they represent the worst case. A detailed description on how the loads are implemented in WellCat can be found in Appendix C.

#### 3.2.4.1 Displacement to Gas (Burst)

This load case models displacement of the mud in the casing to gas. It represents a shut-in well after the well is completely filled with gas, and is commonly used as a worst-case burst criterion for casings with following sections with expected hydrocarbons. It is often called “Maximum Anticipated Surface Pressure (MASP)”. (Halliburton, b)

The formation pressure minus the weight of the gas column makes up the inside pressure (below the wellhead), while the hydrostatic weight of the fluids behind the casing string creates the outside pressure on the casing. The load is given by the difference between these pressures. (Aadnøy, 2010) Normally, the internal pressure is limited to the fracture pressure at the shoe above the open hole TD. (Halliburton, b)

#### 3.2.4.2 Gas Kick (Burst)

This load case simulates maximum pressures seen by the casing while circulating a gas kick to the surface. (Halliburton, b)

The gas bubble will expand when moving up. This expansion is based on a modified BWR<sup>2</sup> equation state. Pressure profiles from the wellbore as a function of gas bubble depth are

---

<sup>2</sup>Benedict Webb Rubin equation

obtained, and after calculating the pressure profile with the gas bubble at surface, a locus of maximum pressures at each depth is used as the load case. (Halliburton, b)

Gas kick load case makes the following assumptions (Halliburton, b):

- Kill mud weight is the same as the initial mud weight (Driller's Method).
- Mud density does not vary with temperature and pressure.
- Annular frictional pressure losses are ignored.

Statoil regulations require a 4 m<sup>3</sup> gas kick volume when no gas is expected. Equations for required bottomhole pressure (Eq. A.12) and further information on this load case can be found in Appendix C.

### 3.2.4.3 Pressure Test

During completion and workover, a number of pressure tests are usually performed. These are done to check production tubing and packer for leaks, as well as confirming that the hanger is what holding the pressure, not the formation. The maximum pressures that may occur during completion operations should therefore be established as Section Design Pressure (SDP) for the production casing. (Aadnøy, 2010)

The pressure test is based on the “highest pressure expected to be seen at the wellhead”, which is usually given by a gas filled casing scenario for the burst evaluation. This should be included in the production casing design for the drilling phase. A similar pressure will occur if there is a tubing leak below the wellhead. (Aadnøy, 2010)

This load case applies a specified pump pressure at the surface. The pressures in the casing and below the plug are calculated based on the density of the specified fluid. As the deeper casings are not cemented to the wellhead, they have a drilling fluid or a completion fluid above the top of the cement. (Halliburton, b)

The requirements states that the “differential pressure from the pressure test should at all depths below wellhead or liner hanger be equal to or higher than any differential pressure...”. In addition, a 15 bar bullheading margin for casings with OD  $\geq 16$ ” is added, and a 35 bar margin for casings with OD  $< 16$ ”. This is also called the kill margin.

### 3.2.4.4 Tubing Leak

Tubing leaks at the top of the production tubing (just below the wellhead) may occur during well testing or production. The production string is usually installed with a packer at the bottom, which isolates the annuli above or below. In regards to the pressure across the tubing wall, the outside pressure is caused by a completion fluid, while the inside pressure is caused by gas. In the case of a leak, the inside tubing pressure is superimposed on top of the casing/tubing annulus. Thus, a substantial pressure occurs in the casing annulus due to the hydrostatic head. (Aadnøy, 2010) As the pressure is transmitted down the annulus, it will generate collapse loads on the tubing and burst loads on the casing. (Bellarby, 2009)

This load case is used to model a tubing leak when analysing the innermost casing. (Halliburton, b)

#### **3.2.4.5 Green Cement Test**

This load case models a pressure test during a primary cement job after bumping the plug, meaning that the cement is still fluid so that the shoe of the casing is not fixed. The model is performing an internal pressure test immediately after bumping the plug during the primary cement job. This load case often represents a worst-case tension load. (Halliburton, b)

This load case calculates its own external pressure profile regardless of the external pressure profile previously specified. It is often performed to prevent the formation of a micro-annulus caused by applying a high-test pressure after the cement has hardened and to save operational time. (Halliburton, b)

#### **3.2.4.6 Lost Returns with mud**

Lost returns with mud is a collapse load that models pressures corresponding to a mud drop while drilling below the shoe. This mud drop is calculated by assuming the hydrostatic column of mud in the hole equilibrates with a specific pore pressure at the specified loss zone measured depth. (Halliburton, b) The loss zone depth chosen corresponds to the measured depth with the lowest pore pressure (in s.g.). Meaning the depth that gives the largest mud drop in meters.

The collapse pressure is developed by the decreasing inside pressure due to the lost mud, while the outside pressure remains constant. (Aadnøy, 2010)

#### **3.2.4.7 Full Evacuation**

This load case simulates air/gas in the casing with a zero surface pressure. Both partial and full evacuation can be simulated. (Halliburton, b) This is often the worst collapse load as the internal pressure becomes close to zero, while the outside pressure remains constant. The scenario is only likely in a dry gas well, for wells with high GOR (and in addition the fluid column stays below the last shoe, yielding only gas in the casing above) and for gas injection wells. (Bellarby, 2009)

#### **3.2.4.8 Above/Below Packer**

This load case models a scenario where communication with the reservoir and tubing is assumed lost. In addition, the production casing/liner is filled with production fluid. If production is tried restarted, it will fail to produce due to plugged perforations. Any surface pressure will therefore bleed off to atmospheric column of produced fluid (the pressure inside the casing/liner will be equal to tubing pressure below the packer). If the assumption is made that the tubing is filled with gas, the result would be atmospheric pressure and the load case would in reality represent a full evacuation.

#### **3.2.4.9 Overpull**

This load case models tension in the string due to the air weight of the casing (or buoyed weight in mud). An overpull force can be specified to model additional surface tension applied to the casing. For the GoM specific demands are present. (Halliburton, b)



### 3.2.4.10 Running in Hole

This load case is used to model running casing or tubing into the hole. It is an axial load, but does not represent a load distribution seen by the pipe at one particular time. Instead, it is constructed by calculating the maximum tension seen at each point on the casing string while running the casing in the hole. (Halliburton, b)

The maximum tension experienced by a joint of casing is normally the tension when picking up out of the slips immediately after making up the joint. The imputed axial pseudo-load arising from dogleg-induced bending stress can cause the maximum tension to occur at depths where local well curvature (dogleg severity) was defined. (Halliburton, b)

The buoyed weight of the casing calculated use the Annulus Fluid specified for the current string on the Wellbore. The temperatures specified on the Initial Conditions dialog are used as the temperature profile for the load case. Analysis of this type of load is best done in WellPlan, which is a torque & drag simulator.

### 3.2.4.11 Production

The main issue with production-related conditions is the thermal change to the well. As mentioned, this may generate high-temperature loads with high or low pressures in the tubing. The type of fluid, the pressure and the flow rates affects the temperature the most. (Bellarby, 2009)

Most load cases for well design include short-term loads. However, for production wells, long time effects should be considered. Some factors are: subsidence and compaction, pore pressure reduction over time, particle settling behind the casing and corrosion below the production packer. (Aadnøy, 2010)

The different production load cases used in this thesis are listed below. The setup in WellCat is shown in Appendix C.

- Clean up
- Early stage production
- Short shut-in
- Steady-state production
- Late stage production
- Frac job
- Long shut-in
- Active annulus

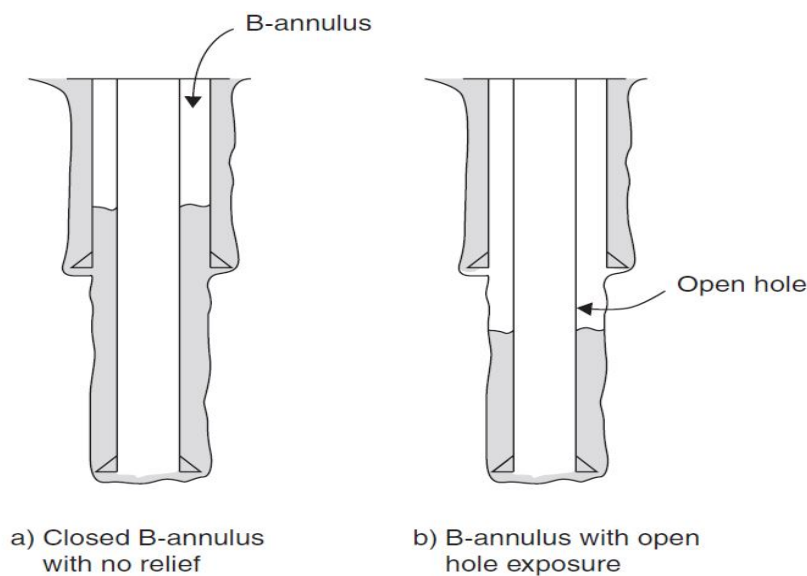
### 3.2.4.12 Shut-in

The long-term shut-in will be exposed to cooling and will fully cool to the geothermal gradient, but will be less extreme than the short-term. (Bellarby, 2009)

The short-term shut-in will be the worst case, with a steady-state production scenario followed by a quick shut-in. The result from this is high temperatures and high pressures. It is often difficult to determine the worst case because the pressure at the wellhead will rise as the temperature falls. (Bellarby, 2009) This is a complex scenario, involving multiphase flow and segregation, and will not be discussed in further detail.

### 3.2.4.13 Annulus Pressure Build-up (APB)

During production and well testing the heat transported from the reservoir up to the wellhead cause a higher temperature profile. This results in volume expansion of the fluids behind the casing strings. This may cause the casing to collapse or burst if these annuli are closed. One way of preventing this is to keep the cement level below the previous casing shoe, ensuring contact between the well and the open hole, as seen in Figure 3.4b. The exposed open hole section may allow for a small fluid loss, thus reducing the pressure. The fracture gradient should act as a safety valve, and should therefore be checked against the pressures. Figure 3.4a shows a closed annulus (provided a high quality cement job is performed). This annulus must therefore be checked for expected pressures. (Aadnøy, 2010)



**Figure 3.4:** APB situations: may/may not cause casing failure. (Aadnøy, 2010)

### 3.2.4.14 Above/below prior shoe external pressure profile

For all burst loads for liners the above/below prior shoe external pressure profile is chosen. This is a Statoil demand. What this does is that it finds the lowest pore pressure both above and below the prior shoe, causing the external pressure to be as low as possible for the two sections. This creates the worst possible case. The profile is quite conservative, and will be discussed later in the thesis.

# Chapter 4

## Results

Due to the deep water, wells in GoM are usually drilled with little or no hole deviation. However, it is clear that horizontal wells will increase recovery significantly. This created the basis for this study, which was looking into details regarding drilling and well design in such wells. The objective of the study was to design a production well for a deepwater ERD well. Both casing design and drilling were investigated with the intention of revealing gaps in existing technology. If the demands could not be met by present technology, the gap was tried identified. Where possible, suggestions were made for improved performance.

A well in the GoM was chosen as a base case. The formation pressure in the well was close to 1,400 bar (20,000 psi), which provided an excellent base for investigating general requirements for deepwater HPHT-like wells. It was of interest to check if a 5 1/2" liner could be used, and if so, if it could be used with a 9 7/8" liner.

The data for the study was provided by Statoil. WellCat<sup>TM</sup> was used to simulate production and casing loads in the well. Based on this, several well designs were investigated. After the requirements for each casing were established, WellPlan was used to investigate the drillability of the chosen well design. The well length was set to 9,660 mMD. The last section of the well had an angle of 88.83°. The water depth at the site was around 2,300 m from Mean Sea Level (MSL) to the mud line, and is therefore categorised as ultradeep water. The pore and fracture data were kept constant, as was the thermal gradient, which was set to 2.19°C/100m. Seawater temperature at the mud line was set to 4°C.

The base case was configured as in Table B.3. Based on this different liners and casing were changed. The mud weights, circulation rates and setting depths were kept constant from design to design. Results and base case information can be found in Appendix B and D. Table 4.2 shows the final well design for the base case.

Table B.3 shows the wellpath setup used in the basecase. Salt formations creates restrictions for kicking off, so the well had to be quite deep before kicking off. Figure B.1 shows the well trajectory of the base case.

### 4.1 Well Design - Case Study

The model was built in WellCat. The procedure for building and obtaining these results are described in Appendix C, with necessary equations in Appendix A. This chapter presents the most important results. Simulation results can be found in Appendix D.

Table 4.1 shows the final well design for the main study. Table 4.2 shows the final well design for the base case (using 10 3/4" liner). The lines marked with grey are pipes with ratings not found in the two investigated vendors' database (VAM Services and Tenaris).

**Table 4.1:** Final Well Design - Case Study (No HC + Gas lift)

OD [in]	ID [in]	Weight [ppf]	Grade	Ratings		
				Burst [bar]	Collapse [bar]	Axial [tonne]
36"	33"	552	X-56	281	185	4129
22"	20"	220.84	X-80	439	267	2394
18"	16.624	128	P-110	510	195	1870
16"	14.438	128	Q-125	736	385	2117
13 5/8"	11.577	128	VM140	1270	1350	2000
9 7/8"	8.013	83	VM140	1585	1600	1000
TB	8.013	83	VM140	1585	1600	1000
5 1/2"	4.25	32.6	Q-125	1715	1735	645

**Table 4.2:** Final Well Design - Base Case (No HC + Gas lift)

OD [in]	ID [in]	Weight [ppf]	Grade	Ratings		
				Burst [bar]	Collapse [bar]	Axial [tonne]
36"	33"	552	X-56	281	185	4129
22"	20"	220.84	X-80	439	267	2394
18"	16.624	128	P-110	510	195	1870
16"	14.438	128	Q-125	736	385	2117
13 5/8"	11.577	128	VM140	1270	1350	2000
10 3/4"	8.684	109	VM140	1623	1676	1125
TB	8.906	97.1	Q-125	1295	1352	1615
5 1/2"	4.25	32.6	Q-125	1715	1735	645

Simulations showed that for the four top most casings the design was the same for the case study and the base case. For the 13 5/8" no existing casing were found that could handle the loads for the given scenario. The same was valid for the 9 7/8" liner and the 10 3/4" liner.

The loads giving the worst differential pressures were first identified. They are presented in Table 4.3. The maximum internal pressure is given at the hanger for each pipe. The differential pressures represent the worst case loads. However, the pressure test is not included in the table. The strategies and requirements for conducting and designing pressure tests vary depending on where in the world the well is located. This is discussed in Chapter 5.3.1.1. The pressure tests were included when investigating the final design. Calculations and pressure test data can be found in Appendix A (Table A.4 and A.5).

**Table 4.3:** Section Pressure Summary - Case Study (No HC + Gas lift)

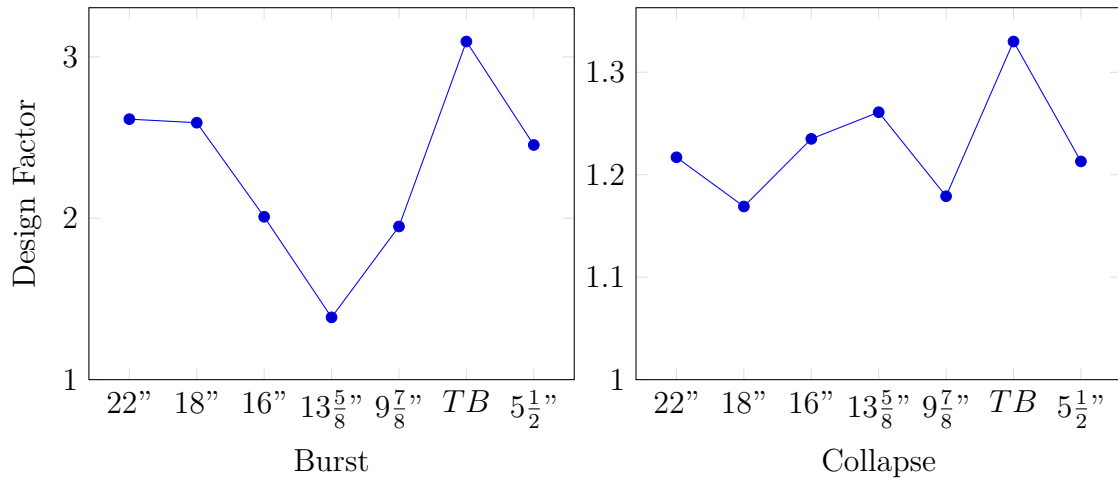
OD [in]	Pint,max[bar]	Pdiff,max[bar]	Pdiff,min[bar]
22"	372	163	-206
18"	431	123	-151
16"	477	353	-245
13 5/8"	961	595	-1047
9 7/8"	1260	240	-1296
9 7/8" TB	623	213	-1150
5 1/2"	1332	50	-1350

Different pipes were then used to verify that they could handle the resulting pressures. If the vendor or Statoil database did not include pipes with the necessary rating, new specifications were identified. Based on the limiting load type (burst/collapse), the necessary wall thickness were calculated. The results from these calculations are shown in Table 4.18. Figure 5.1 shows a graphical representation of the calculations. Collapse gave the highest wall thickness for all sections. The calculations were done by Auristela C. V. Quitero in Statoil, using a self-made code in MatCad. The code was based on the theory presented in Appendix A. The theory only touches the surface of the subject as the equations, and the full theory behind, involve advanced mathematics.

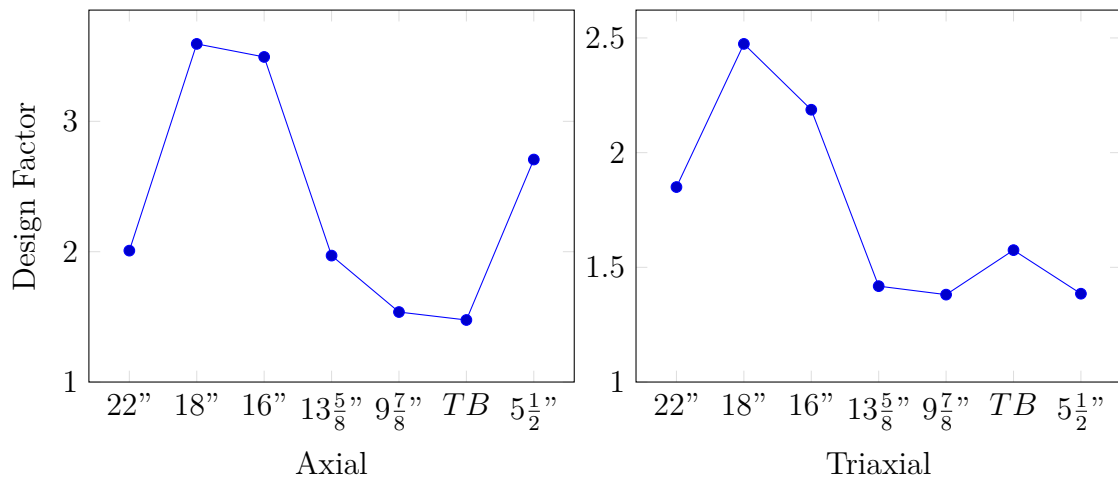
The burst rating for the given wall thickness was calculated using Barlow's equation (Eq. A.1). The weight of the pipes were estimated with a tolerance of 7.5% on the density (WellCat practice). The resulting design factors (absolute minimum safety factors) are shown in Table 4.4. Figure 4.1 and 4.2 shows a graphical representation of this.

**Table 4.4:** Design Factors - Case Study (No HC + Gas lift)

OD [in]	Burst (1.1)	Collapse(1.1)	Axial (1.2)	Triaxial(1.25)
22"	2,614	1,217	2,008	1,850
18"	2,592	1,169	3,594	2,474
16"	2,009	1,235	3,494	2,187
13 5/8"	1,386	1,261	1,970	1,418
9 7/8"	1,949	1,179	1,537	1,381
9 7/8" TB	3,095	1,330	1,476	1,575
5 1/2"	2,454	1,213	2,707	1,385



**Figure 4.1:** Design Factors Case Study - Burst & Collapse



**Figure 4.2:** Design Factors Case Study - Axial & Triaxial

## 4.2 Drilling the Well

The well design used was as described in Table 4.1. WellPlan was used as the simulation tool. The rig specifications used was from the Maersk Developer, described in Appendix B. The goal of this study was to establish if the casing design specified in the previous section could be used. As this was not part of the objectives of this thesis, only the reservoir section was investigated. The setup used in WellPlan can be found in Appendix B.3. A liner gap of 100 m was used.

Synthetic oil-based muds are most commonly used in GoM. In WellPlan, the Herschel-Buckley rheology model was used to best show the properties of the mud. Table B.4 shows the mud densities for each section. Figure B.7 shows the fluid setup.

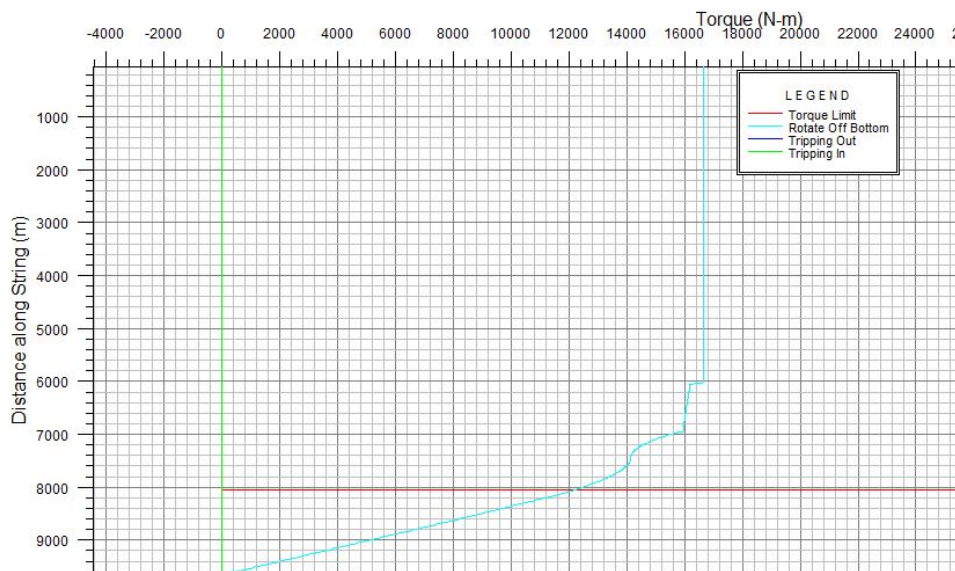
Simulations showed that the section could be drilled using the setup given in Table B.6. Simulation results can be found in Appendix D.3. Torque, tension and hook load were all within their limits. A 1.749 sg synthetic based mud was used in this section. The running string was built with combination of a 6 5/8" DP (58.81 ppf) and a 5 7/8" DP (23.4 ppf). The study was done to investigate if the section was drillable.

Investigations of hole cleaning showed that the riser needed a flow rate of 2,860 L/min to stay clean. However, this rate was not needed for the hole. Figure D.41 shows that the minimum flow rate needed in the hole was 1,100 L/min. A booster pump was added with an injection rate of 1,500 L/min. With a minimum of 1,360 L/min passing through the bit and 1,500 L/min through the riser, the total flow in the riser added up to 2,860 L/min. The minimum flow in the open hole was therefore dimensional.

Further investigations showed that the flow rate limit was at 1,800 L/min. Figure D.42 shows the resulting ECD when using this rate. Increasing the rate above this could lead to lost circulation or reservoir damage.

The overpull margin was 92 t for this case, which is just at the limit of 91 t (GoM requirement). Figure D.39 shows the resulting Von Mises stress on the pipe. This can be seen as “the sum of all stresses”. As seen in the figure, the stress is below the Stress Limit.

Simulations showed that the liner could be run using the setup given in Table B.7. Simulation results can be found in Appendix D.3. Tension and hook load were both within their limits, torque was not. Figure 4.3 shows that at 8,042 m the pipe will fail. This is exactly in the transition from 5 7/8” DP to the 5 1/2” liner. As a result, the liner may not be rotated all the way down. The overpull margin was 108 t for this case, which is well above the limit of 91 t. A 1.749 sg synthetic based mud was used in the simulations. A combination of 6 5/8” (34 ppf) and 5 7/8” (23.4 ppf) drillpipes were used in the landing strings.



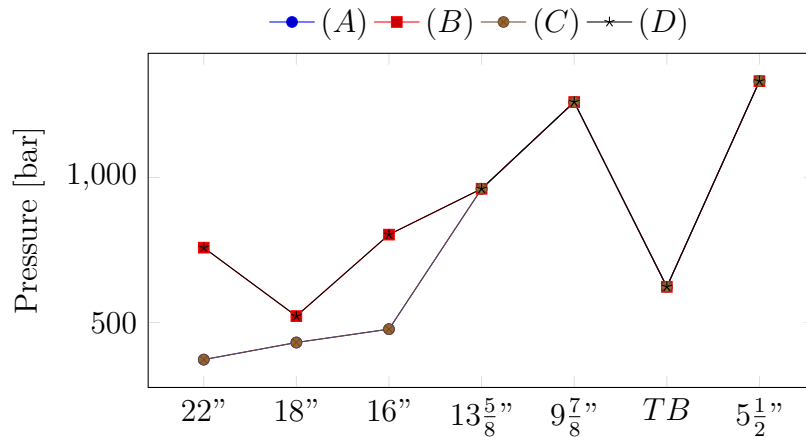
**Figure 4.3:** Torque - Running 5 1/2” Liner (WellPlan)

Table B.8 shows the input for the cement job. The simulations showed that cementing the liner would be possible based on ECD. Figure D.46 shows the resulting rates from the cement job. Figure D.47 shows the resulting ECD.

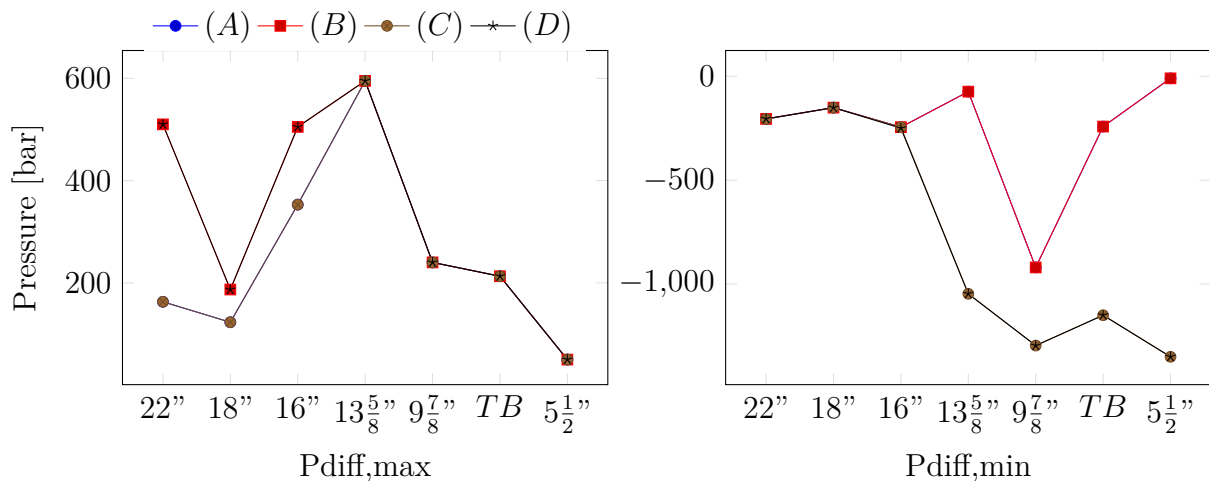
### 4.3 Sensitivities

Several aspects affect the outcome of a well design study. During the process many assumptions and considerations were made. In this chapter some of these were tested to see what effect they had on the design. First, three different scenarios were investigated. These included: (A) No hydrocarbons are expected before the 13 5/8" is set, (B) Hydrocarbons cannot be excluded and (D) Hydrocarbons cannot be excluded and gas lift is planned. These complement the main study, which was (C) No hydrocarbons expected and gas lift is planned. In addition, some sensitivities were investigated for the main study. This included some WellPlan settings, running fluid for the tieback, squeezing salt and a wall thickness comparison for different yield strengths.

Figure 4.4 shows the the maximum internal pressure for all four scenarios. This is a graphical representation of the data found in Table 4.8, 4.9 and 4.10. Figure 4.5 shows the maximum and minimum internal pressure.



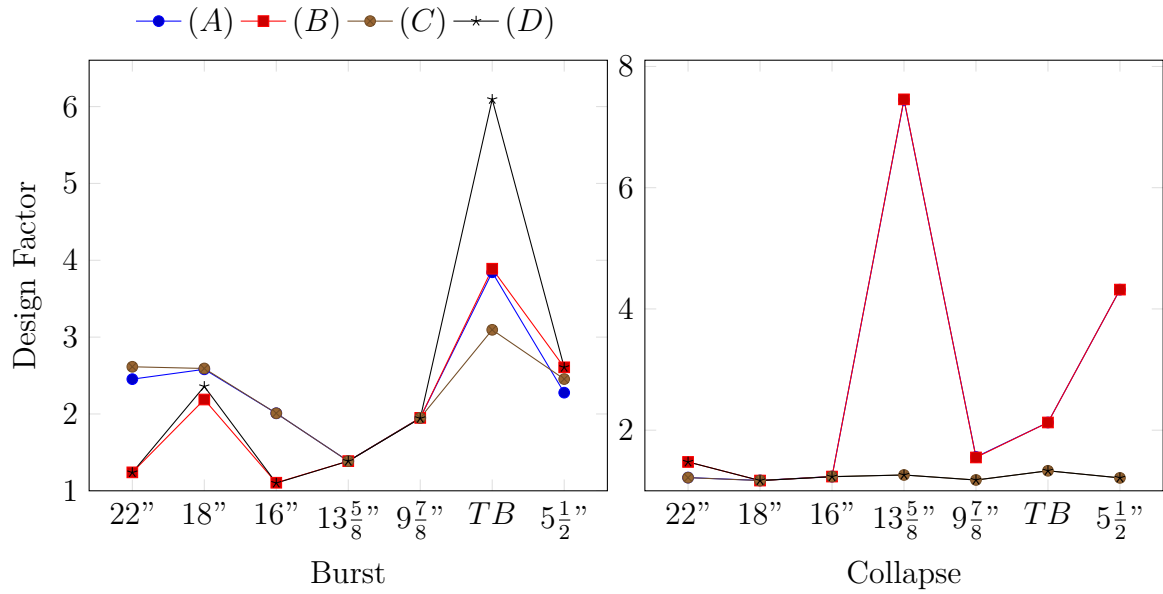
**Figure 4.4:** Maximum Internal Pressure - Sensitivities



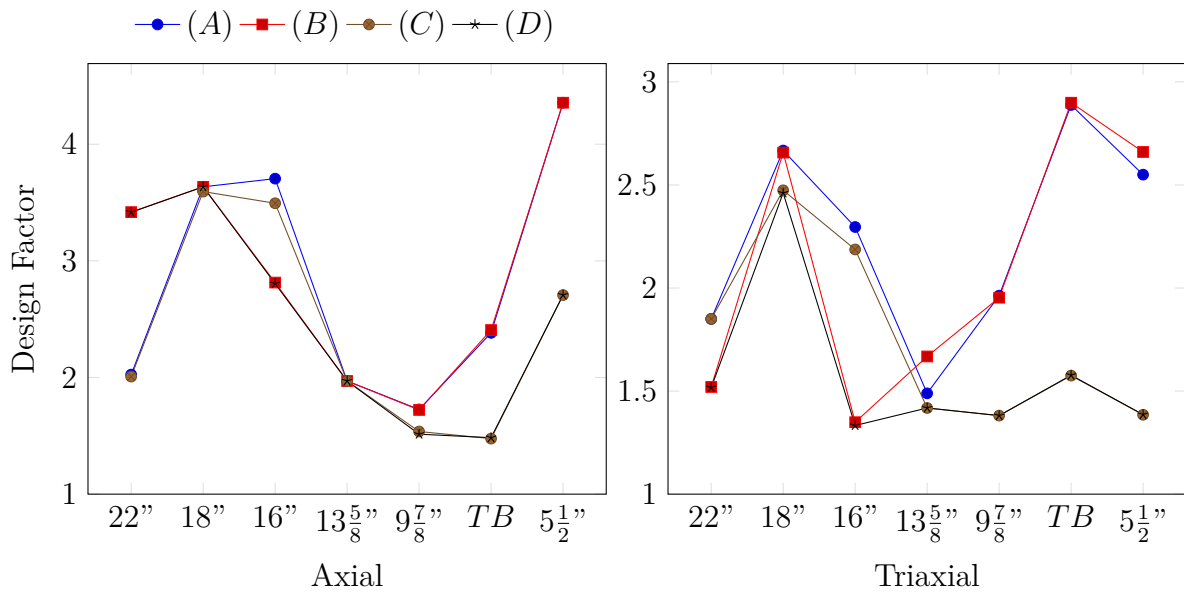
**Figure 4.5:** Minimum and Maximum Differential Pressure - Sensitivities

Figure 4.6 shows the design factors for burst and collapse, while Figure 4.7 shows the design factors for axial and triaxial.





**Figure 4.6:** Design Factors Sensitivity - Burst & Collapse



**Figure 4.7:** Design Factors Sensitivity - Axial & Triaxial

Table 4.5 to 4.7 shows the final well design for the sensitivities. Table 4.8 to 4.10 shows the resulting pressures for each scenario, with pressures presented as worst case per section. Table 4.11 to 4.13 shows the resulting design factors. These sensitivities are discussed in Chapter 5.2.3.

**Table 4.5:** Final Well Design - Sensitivity (No HC)

OD [in]	ID [in]	Weight[ppf]	Grade	Ratings		
				Burst [bar]	Collapse [bar]	Axial [tonne]
36"	33"	552	X-56	281	185	4129
22"	20"	220.84	X-80	439	267	2394
18"	16.624	128	P-110	510	195	1870
16"	14.438	128	Q-125	736	385	2117
13 5/8"	11.577	128	VM140	1270	1350	2000
9 7/8"	8.013	83	VM140	1585	1600	1000
9 7/8" TB	8.553	66.4	Q-125	1010	870	1090
5 1/2"	4.25	32.6	Q-125	1715	1735	645

**Table 4.6:** Final Well Design - Sensitivity (HC)

OD [in]	ID [in]	Weight[ppf]	Grade	Ratings		
				Burst [bar]	Collapse [bar]	Axial [tonne]
36"	33"	552	X-56	281	185	4129
22"	20"	220.84	Q-125	686	324	3740
18"	16.624	128	P-110	510	195	1870
16"	14.438	128	Q-125	736	385	2117
13 5/8"	11.577	128	VM140	1270	1350	2000
9 7/8"	8.013	83	VM140	1585	1600	1000
9 7/8" TB	8.553	66.4	Q-125	1010	870	1090
5 1/2"	4.25	32.6	Q-125	1715	1735	645

**Table 4.7:** Final Well Design - Sensitivity (HC + Gas lift)

OD [in]	ID [in]	Weight[ppf]	Grade	Ratings		
				Burst [bar]	Collapse [bar]	Axial [tonne]
36"	33"	552	X-56	281	185	4129
22"	20"	220.84	Q-125	686	324	3740
18"	16.624	128	P-110	510	195	1870
16"	14.438	128	Q-125	736	385	2117
13 5/8"	11.577	128	VM140	1270	1350	2000
9 7/8"	8.013	83	VM140	1585	1600	1000
9 7/8"	8.013	83	VM140	1585	1600	1000
5 1/2"	4.25	32.6	Q-125	1715	1735	645

**Table 4.8:** Section Pressure Summary - Sensitivity (No HC)

OD [in]	Pint,max[bar]	Pdiff,max[bar]	Pdiff,min[bar]
22"	372	163	-206
18"	431	123	-151
16"	477	353	-245
13 5/8"	961	595	-74
9 7/8"	1260	240	-920
9 7/8" TB	623	213	-242
5 1/2"	1332	50	-10

**Table 4.9:** Section Pressure Summary - Sensitivity (HC)

OD [in]	Pint,max[bar]	Pdiff,max[bar]	Pdiff,min[bar]
22"	758	510	-205
18"	522	187	-151
16"	803	505	-245
13 5/8"	961	595	-74
9 7/8"	1260	240	-920
9 7/8" TB	623	213	-242
5 1/2"	1332	50	-10

**Table 4.10:** Section Pressure Summary - Sensitivity (HC + Gas lift)

OD [in]	Pint,max[bar]	Pdiff,max[bar]	Pdiff,min[bar]
22"	758	510	-205
18"	522	187	-151
16"	803	518	-245
13 5/8"	961	595	-1047
9 7/8"	1260	240	-1296
9 7/8" TB	623	213	-1150
5 1/2"	1332	50	-1350

**Table 4.11:** Design Factors - Sensitivity (No HC)

OD [in]	Burst (1.1)	Collapse(1.1)	Axial (1.2)	Triaxial(1.25)
22"	2,453	1,218	2,025	1,850
18"	2,581	1,171	3,635	2,667
16"	2,009	1,235	3,705	2,296
13 5/8"	1,386	7,449	1,970	1,489
9 7/8"	1,949	1,558	1,726	1,963
9 7/8" TB	3,844	2,127	2,383	2,888
5 1/2"	2,277	4,318	4,356	2,550

**Table 4.12:** Design Factors - Sensitivity (HC)

OD [in]	Burst (1.1)	Collapse(1.1)	Axial (1.2)	Triaxial(1.25)
22"	1,240	1,476	3,418	1,520
18"	2,188	1,169	3,635	2,657
16"	1,105	1,235	2,814	1,349
13 5/8"	1,386	7,457	1,970	1,668
9 7/8"	1,949	1,550	1,722	1,953
9 7/8" TB	3,890	2,127	2,407	2,899
5 1/2"	2,607	4,319	4,356	2,660

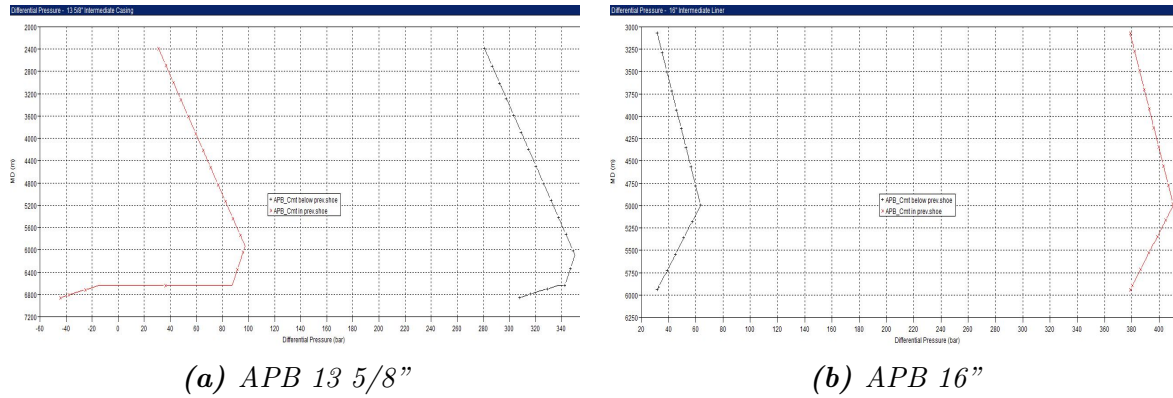
**Table 4.13:** Design Factors - Sensitivity (HC + Gas lift)

OD [in]	Burst (1.1)	Collapse(1.1)	Axial (1.2)	Triaxial(1.25)
22"	1,238	1,476	3,417	1,517
18"	2,358	1,169	3,635	2,461
16"	1,101	1,232	2,805	1,333
13 5/8"	1,386	1,261	1,970	1,418
9 7/8"	1,943	1,177	1,514	1,381
9 7/8" TB	6,094	1,330	1,484	1,577
5 1/2"	2,607	1,213	2,707	1,386

### 4.3.1 Sensitivities for the Main Study

#### 4.3.1.1 13 5/8" TOC

As the base case setup showed that top of cement for the 13 5/8" casing only was 150 m below the previous shoe, a sensitivity study was done to see the effects of having the TOC inside the previous shoe (16"liner). TOC was set to 5,940 m (3 m inside the previous shoe). Figure 4.8 shows the resulting differential pressures for the annular pressure build-up load case (APB). As seen in the figures, cementing into the previous shoe leads to the following: (1) for the 13 5/8" casing, it will have a collapse effect, (2) for the 16", it will have a burst effect. Table 4.14 shows the resulting changes in the DFs for the 16" liner (no effects were seen on the DFs for the 13 5/8").



**Figure 4.8:** Differential pressure for APB - TOC in 16" shoe versus below shoe.

**Table 4.14:** Design Factors - TOC in 16" shoe versus below the shoe

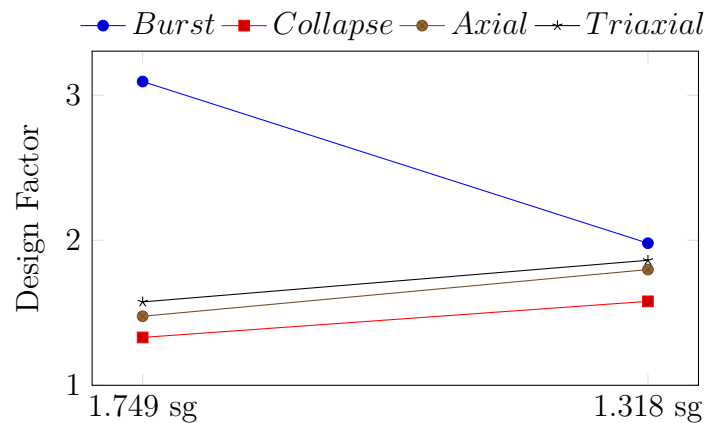
OD [in]	Burst (1.1)	Collapse(1.1)	Axial (1.2)	Triaxial(1.25)
In shoe	1,752	1,235	3,451	2,178
Below shoe	2,009	1,235	3,494	2,187

#### 4.3.1.2 Running fluid for Tieback

The fluid density for running the tieback was set to 1.749 sg, which was the density used when drilling the reservoir section. This gave overbalance to reservoir pressure. However, running the tieback in a lighter fluid will have an effect on the design specifications needed for the pipe. In this study, the tieback was simulated run in a packer fluid with density of 1.318 sg. Table 4.15 shows the resulting DFs. Figure 4.9 shows a graphical representation of this. The burst-DF decreased, while the collapse-DF increased.

**Table 4.15:** Design Factors - Running Tieback in Packer Fluid (1.318 sg)

OD [in]	Burst (1.1)	Collapse(1.1)	Axial (1.2)	Triaxial(1.25)
1,749 sg	3,095	1,330	1,476	1,575
1,318 sg	1,980	1,579	1,798	1,862



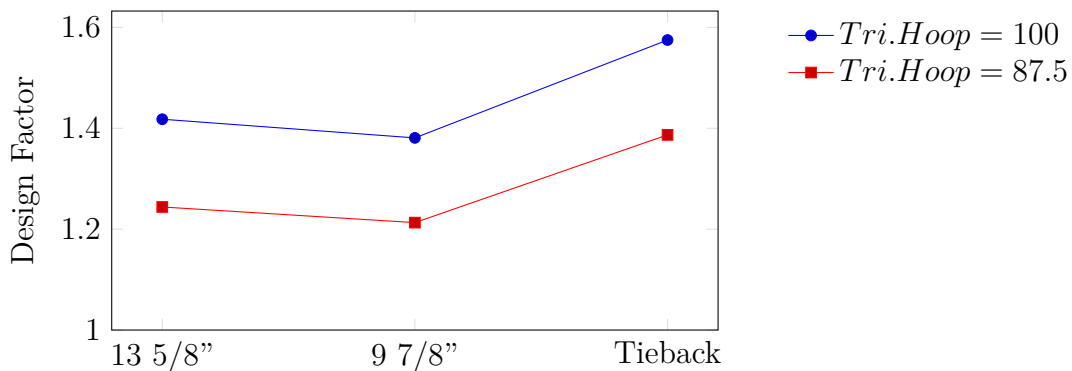
**Figure 4.9:** Design Factors - Running Tieback in Packer Fluid

### 4.3.1.3 Triaxial Hoop

In the section for pipe specifications there is a column called triaxial hoop. This is pre-set to 87.5 in the Statoil database. Since the API correction factor (0.875) is already included in the triaxial safety factor, the Triaxial Hoop must be set to 100. If this is not done, the real DF would become higher than the specified 1.25 for triaxial analysis. Table 4.16 shows the results from the sensitivity analysis. Figure 4.10 shows a graphical representation of this. It shows that the triaxial-SF will become to low when using 87.5. This will be discussed in Chapter 5.2.3.

**Table 4.16:** Design Factors - Effect of Triaxial Hoop

Triaxial Hoop	OD [in]	Burst (1.1)	Collapse(1.1)	Axial (1.2)	Triaxial(1.25)
100	13 5/8"	1,386	1,261	1,970	1,418
	9 7/8"	1,949	1,179	1,537	1,381
87,5	13 5/8"	1,386	1,261	1,970	1,244
	9 7/8"	1,949	1,179	1,537	1,213



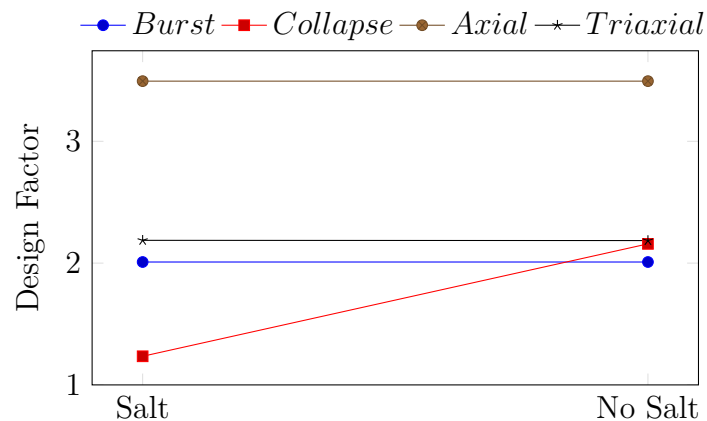
**Figure 4.10:** Triaxial Design Factors - Effect of triaxial hoop

### 4.3.1.4 Squeezing Salt

In the chosen well, a salt formation was present in the 16" section. However, a study were done to see the general effect of such a formation. The result of this is shown below. Table 4.17 shows the resulting DFs with and without salt formations. The effect were only seen on the collapse load. Figure 4.11 shows a graphical representation of this. Figure D.48 in Appendix D shows the resulting differential pressures.

**Table 4.17:** Design Factors - With/Without Salt Formations

OD [in]	Burst (1.1)	Collapse(1.1)	Axial (1.2)	Triaxial(1.25)
Including Salt	2,009	1,235	3,494	2,187
No Salt	2,009	2,158	3,494	2,185



**Figure 4.11:** Design Factors - With/Without Salt Formations

#### 4.3.1.5 WT versus Yield Strength

The calculations for wall thickness were done for three yield strengths (grades). This was done to see the effect of the YS on wall thickness, as well as providing results for the well design. This gave the opportunity to optimize the new specifications based on both well design and drillability aspects. Table 4.18 to 4.21 shows the calculated wall thickness for each scenario, presented for the 13 5/8" and the 9 7/8". Figure 5.1 shows a graphical representation of the wall thickness calculations for the case study. As some of the casings were used in multiple scenarios, some of the values are repeated in the tables.

**Table 4.18:** Wall Thickness Calculations - Case Study (No HC + Gas lift)

OD [in]	Based on Burst [mm]			Based on Collapse [mm]		
	110ksi	125ksi	140ksi	110ksi	125ksi	140ksi
13 5/8"	15,64	13,76	12,29	31,11	27,77	26,5
9 7/8"	4,56	4,01	3,58	29,75	25,71	22,65

**Table 4.19:** Wall Thickness Calculations - Sensitivity ((A) NoHC)

OD [in]	Based on Burst [mm]			Based on Collapse [mm]		
	110ksi	125ksi	140ksi	110ksi	125ksi	140ksi
13 5/8"	15,64	13,76	12,29	-	-	-
9 7/8"	4,56	4,01	3,58	22,55	20,13	19,2

**Table 4.20:** Wall Thickness Calculations - Sensitivity ((B) HC)

OD [in]	Based on Burst [mm]			Based on Collapse [mm]		
	110ksi	125ksi	140ksi	110ksi	125ksi	140ksi
13 5/8"	15,64	13,76	12,29	-	-	-
9 7/8"	4,56	4,01	3,58	19,26	18,27	17,57

**Table 4.21:** Wall Thickness Calculations - Sensitivity ((D) HC+Gas Lift)

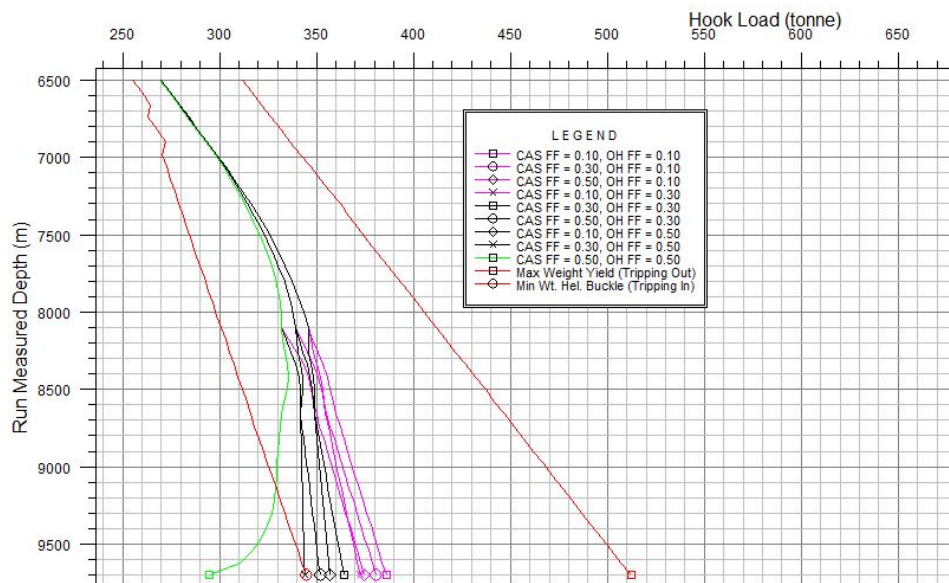
OD [in]	Based on Burst [mm]			Based on Collapse [mm]		
	110ksi	125ksi	140ksi	110ksi	125ksi	140ksi
13 5/8"	15,64	13,76	12,29	31,11	27,77	26,50
9 7/8"	4,56	4,01	3,58	29,75	25,71	22,65

#### 4.3.1.6 Friction Factors - WellPlan

A study on the effect of friction factors were done in the Project Thesis. When testing this, no changes were made besides the friction factors. This study was done on the base case setup for the reservoir section. Table 4.22 shows the results of the sensitivity simulations. Figure 4.12 shows a sensitivity plot for different friction factors when tripping in.

**Table 4.22:** Effect of different friction factors on torque and drag

Friction Factor (CH/OH)	Surface Torque (ON Bottom) [kNm]	Surface Torque (OFF Bottom) [kNm]	Max drag in [kN]	Max drag out [kN]
0.17/0.20	26.0	18.4	-232	213
0.17/0.30	33.6	25.8	-345	308
0.25/0.35	39.2	31.2	-456	399
0.28/0.35	39.9	31.9	-477	416
0.32/0.36	41.6	33.5	-529	451
0.33/0.38	43.4	35.2	-577	482
0.38/0.45	49.9	41.4	-866	610

**Figure 4.12:** Sensitivity on friction factors when tripping in (WellPlan)



# Chapter 5

## Discussion and Evaluation

The foundation of this Master Thesis was to investigate well design requirements for Deepwater ERD wells. A well in the GoM was chosen as a case study. Landmark's WellCat was used as simulation tool. The results were then compared with similar simulations done by Statoil. After verifying the model behaviour, the program was used to perform a sensitivity study on selected parameters.

### 5.1 Deepwater Challenges

Drilling in deepwater environments are currently drilled with low angle and limited reservoir penetration. However, economic development of these reserves requires drilling much higher inclination wells. The experience with high angle wells in this environment is limited and there are uncertainties to the feasibility of this type of wells. A study on well design and drillability was therefore of interest.

To drill and complete deepwater wells successfully, sophisticated technologies must be applied to overcome the various challenges. The most recognized deepwater challenge is probably the narrow pressure window while drilling. Since the fracture pressure gradient in deep water decreases more than in shallow water, ECD control will be even more critical to avoid damaging the formation. Several challenges creates a demand for advanced rigs and expensive customized equipment. Techniques as such as Managed Pressure Drilling (MPD) and Dual-Gradient Drilling (DGD) can handle many of these challenges and thus lowering the bar. These types of techniques provide a method for manipulating the pressure window, making the potential of implementing them huge.

Cementing and ECD management are critical aspects with regards to completion operations. Low clearance at TD, heavy cement and small pressure windows creates difficult conditions for successful cement jobs. This will in many cases limit the length of the well as, cementing may not be possible TD.

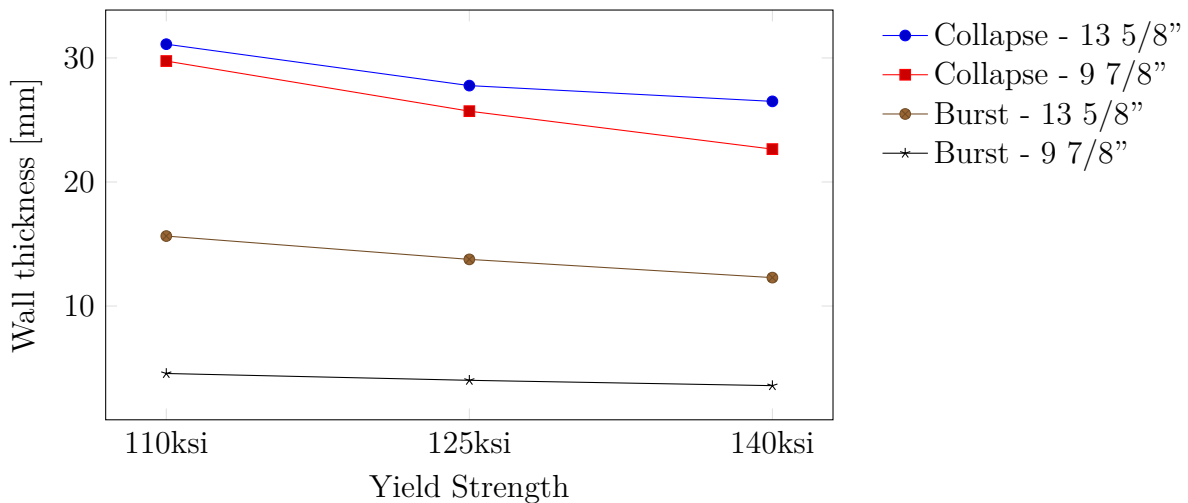
### 5.2 Simulation Results

The main result from the study were that two new casings were needed to be able to design this well with the given requirements. This included a 13 5/8" and a 9 7/8" casing with the specifications given in Table 4.1. Both with a yield strength of 140ksi. Using a lower yield strength would be possible, though this might decrease the success rate of the completion process. The drillability study showed that the chosen 5 1/2" liner could be used and run. However, the liner could not be rotated all the way down. This might prevent getting a successful liner job.

### 5.2.1 Well Design

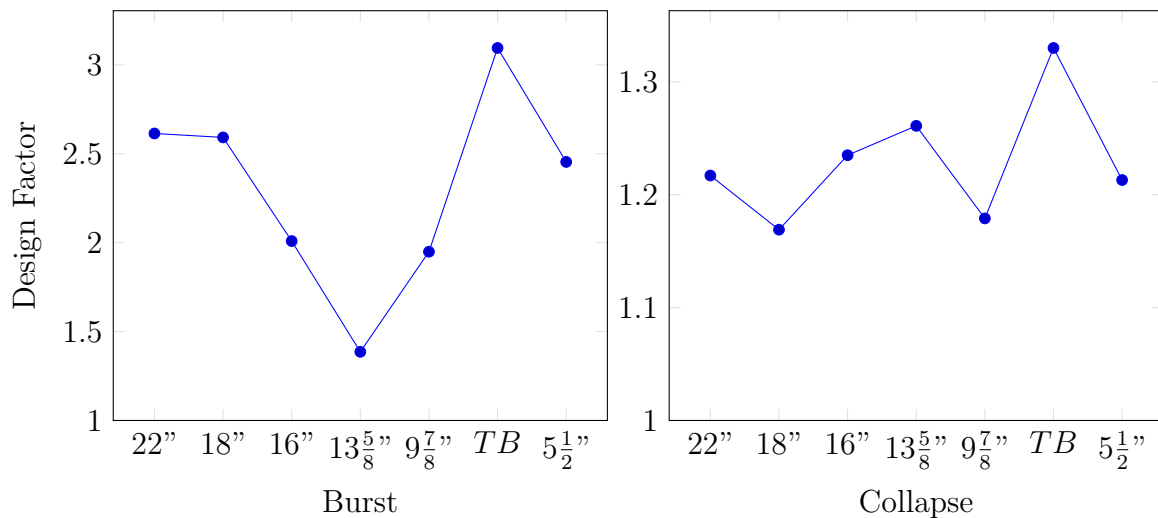
The main case study was based on a well with no expected hydrocarbons until the 13 5/8" casing was set. In addition, gas lift was included. A sensitivity study were later done where scenarios with expected hydrocarbons in the shallower sections were included, along with gas lift. The loads were based on Statoil requirements and simulated in Landmark's WellCat.

Investigations showed that collapse was the limiting factor for all casings. This can be seen in Figure 5.1, shown for the 13 5/8" and the 9 7/8". The required wall thickness for the two pipes were higher for collapse than for burst. The load type giving the highest required wall thickness were used as the limiting factor. As seen in the figure, the calculated WT from collapse requirements were as high as 6.5 times higher than the resulting WTs from burst ( $29.75\text{mm}/4.56\text{mm} = 6.52$ ). This caused the burst rating on the pipes to be over-dimensioned. The calculations are discussed in Chapter 5.3.2. Based on the high collapse loads, specifications for two new casings were identified. A weakness with this conclusion is that only two vendors were checked (Vam Services and Tenaris). However, the available casings at the two vendors were far from the required ratings found in this thesis. The extreme nature of the collapse requirement is believed to be higher than the existing majority of pipes used for "normal" wells. In addition, high collapse pipes were not investigated. This type of pipe could present better ratings than normal pipes.



**Figure 5.1:** Wall Thickness - Calculation Results Case Study

Figure 5.2 shows the resulting design factors for burst and collapse. This shows that the DFs for burst are well above the limit of 1.1. The DFs for collapse are also above the limit, though with less margin. As an extreme example, the burst-DF for the tieback was 227% higher than the SF limit, while the collapse-DF for the tieback was only 20% higher. A general discussion on design factors can be found in Chapter 5.3.2.



**Figure 5.2:** Design Factors Case Study - Burst & Collapse

The specifications for the two new casings can be found in Table 4.1. The wall thickness was calculated based on a 140ksi yield strength. This was to get the wall thickness as low as possible, so that the clearance would be maximized for the drilling and cementing process. Using a lower yield strength would be possible from a well design perspective, though this might decrease the success rate of the completion process (drillability). The weights listed in the table are an estimation based on a tolerance of 7.5% on the density (WellCat practice).

## 5.2.2 Drilling the Well

The design found in the well design study were used in the drillability study. As the objective of this thesis was to investigate the well design with regards to pressure demands, only the reservoir section was evaluated in the drillability study. Some observations were made on some of the sections not investigated.

The study showed that the reservoir sections was drillable with the given specifications. Both the rig and the chosen pipes were able to withstand the operations performed. A booster pump had to be installed to handle the cleaning of the riser. This was somewhat expected, as similar findings were found during the Project Thesis. The riser has over twice as large ID as the 8 1/2" hole, so an increase in needed flow rate is intuitive. As the minimum pump rate needed to clean the hole was found to be 1,100 L/min, and the limit before fracturing the formations was 1,800 L/min, ECD problems were not an issue for this well. This was somewhat unexpected. However, the low-OD liner (5 1/2") would normally be run in a smaller OH, so the clearance was better in this case. It is important to have a good liner job to get the completion solution in place. For this well, a frac pack is the main plan.

The 5 1/2" liner could not be rotated all the way down. These findings were similar to the findings of Statoil. An explanation to this might be the limitations on DP size when running the liner. This further limits the strength and weight of the running string. The combination of a deep kick off and long wellpath creates high torque values, which could cause the pipe to break if tried rotated.

For the cement job, a spacer was used with heavier density than the mud, and lower density than the cement. The higher density of the cement causes the fluids to U-tube back, thus closing the float. A cement density of 1.97 sg was used. This counts as gas tight cement. The study showed that the liner could be cemented without exceeding the fracture pressure. This was highly dependent on the OD of the pipes used, and the length of the liner. This is explained by the differences in clearance, which impacts the ECD. The authors experience with cement simulations is the main limitation of the cement analysis. However, it is believed that the analysis shows a good picture, as similar results were obtained by Statoil. However, it is not advised to plan a well based on these simulations.

If problems with ECD during cementing, foam cement would be a possible solution. One possibility would be to plan for a 200 m gas tight cement at the bottom of the cement job, with a 1.55-1.65 sg above, though this has not been simulated. The only exception here would be that a hydrocarbon zone should be covered with gas tight cement. The differences seen in Figure D.46 on flow rate in and out are caused by U-tubing effects, e.g. heavier fluids in free fall.

The top drive hoisting capacity is 2,500 klbs. However, the weight of the top drive (59.5 klbs) and the crown block weight (26.5 klbs) should be subtracted from this. If a safety factor of e.g. 1.1 is included, the resulting maximum string weight should not exceed 2,200 klbs. This is an important note in regards to the weight of the 13 5/8" casing. High enough grade must be used so that the density of the pipe is kept to a minimum. In addition, the choice of grade is critical for the clearance between the 13 5/8" casing and 9 7/8" liner, as well as the clearance between the 16" and the 13 5/8" casing. A maximum ID will create greater clearance between the pipe and the connections passing through.

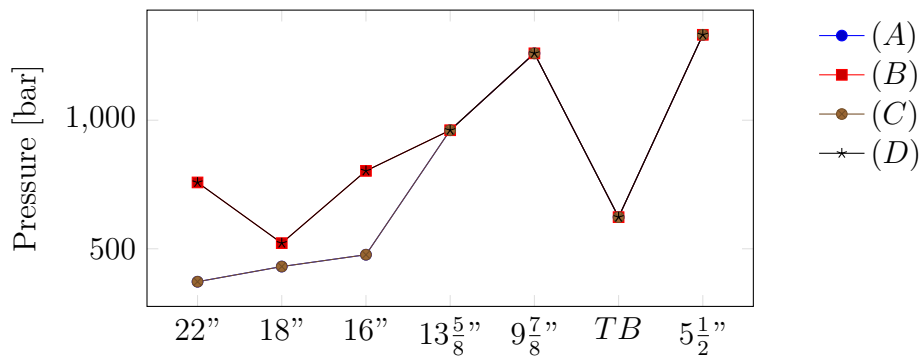
### 5.2.3 Sensitivities

Several aspects affect the outcome of a well design study. During the process of the simulations in this thesis many assumptions and considerations were made. A sensitivity study was done to test the effect of some of these assumptions. First, three different scenarios were investigated. These included: (A) No hydrocarbons are expected before the 13 5/8" is set, (B) Hydrocarbons cannot be excluded and (D) Hydrocarbons cannot be excluded and gas lift is planned. These complement the main study, which was (C) No hydrocarbons expected and gas lift is planned. In addition, some sensitivities were investigated for the main study. This included some WellCat settings, running fluid for the tieback, squeezing salt and a wall thickness comparison for different yield strengths.

#### 5.2.3.1 Different Scenarios for HC and Gas Lift

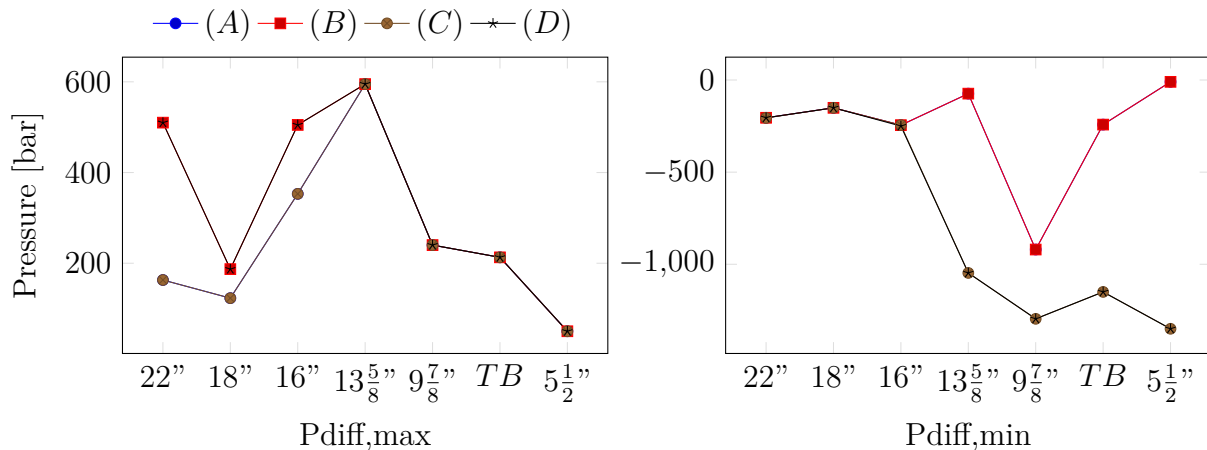
Figure 5.3 shows the maximum internal pressure seen in the different scenarios. As expected, the pressures were identical for the 13 5/8" and smaller. The internal pressure were governed by the worst case of gas kick, displacement to gas and tubing leak. For the 13 5/8" casing and smaller, the requirements for which load cases simulated were the same, yielding the same setup for all scenarios. The figure also shows that scenario A & C and B & D had the same internal pressure for the three top most sections. This was also expected, as A and C are both based on the assumption that no hydrocarbons were expected until the 13 5/8" casing were set. Thus, gas kick was the worst case for both of

them. For scenario B and D, both were simulated expecting hydrocarbons in the shallow sections, requiring DTG in all sections. This gave higher internal pressure, as seen in the figure. For the 18" liner, the maximum differential pressures were significantly lower than the pressure seen for the 22" and the 16" (for DTG). This is caused by the fact that the 18" liner is protected by the 16" liner when drilling the 17 1/2" section (for the 13 5/8" casing). It is during this section the highest pore pressure would be seen, and thus the highest resulting SIWHP. The simulations showed that the formation would fracture if a GK or DTG was to occur when drilling the section for the 16" liner.



**Figure 5.3:** Maximum Internal Pressure - Sensitivities

Figure 5.4 shows the maximum and minimum differential pressures for the four scenarios investigated. As for the internal pressure, the maximum differential pressures were equal for the four scenarios when looking at the 13 5/8" and smaller. As the maximum differential pressure were based on the highest internal pressure, this was a natural result. This was expected based on the same reasoning as for the internal pressure. For the three top most sections, scenario A and C were also here the same, as were B and D. For the minimum differential pressure, the results were sections wise opposite of the maximum differential pressure. The three top most sections were the same and the 13 5/8" and smaller were divided. This is caused by the simulations requirements when including gas lift. The requirements say that if gas lift is planned, full evacuation has to be included as a load case. This gave the worst load case for the collapse. For A and B, where gas lift was not included, the above/below packer gave the worst case. Both are severe collapse loads, creating high demands for the well design.



**Figure 5.4:** Minimum and Maximum Differential Pressure - Sensitivities

Table 4.5 shows the final well design for scenario A with no expected hydrocarbons and no plans for gas lift. The same casings were used for the four top most sections as were used in the main study. As mentioned, the burst requirements regarding the 13 5/8" were the same for all scenarios. The collapse requirements for the same casing were lower for this scenario, where no gas lift was planned. The difference between the minimum differential pressures was approximately 370 bar. Scenario A showed a minimum differential pressure of 920 bar. The highest collapse rating found from the two vendors were 560 bar (Tenaris Q-125, 105ppf). For this reason, the scenario were simulated using the proposed 13 5/8" casing from the case study. As seen in Figure 4.6, this provided a collapse resistance that was significantly over-dimensioned. While the collapse-DF for the cases including gas lift was just below 2, the collapse-DF for the A and B were approximately 7,5.

The same observations for the 13 5/8" casing and 9 7/8" liner were made for scenario B, where hydrocarbons were expected in the top sections. The main difference from scenario A and C were that a stronger 22" casing would have to be used. Scenario A and C both were excluding hydrocarbons in the top sections, thus only simulating a gas kick. A fully displaced well to gas would give significantly higher SIWHP than a gas kick. This can be seen in Table 4.8 versus Table 4.9. Figure 5.3 shows this graphically.

The same 22" casing was needed for the worst case well design, scenario D. As this scenario included both expected hydrocarbons in the top section as well as plans for gas lift, this clearly provides the most conservative scenario. In addition to the observations mentioned for the two scenarios mentioned above, the new 140ksi 9 7/8" pipe would have to be run as tieback. This is the same as the conclusion for the case study. For the two scenarios without plans for gas lift, a lighter casing pipe could be used for the tieback.

### 5.2.3.2 13 5/8" TOC

As the base case setup shows that the top of cement for the 13 5/8" casing only was approximately 150 m below prior shoe, a sensitivity study was done on the effects if the TOC was inside the previous casing. This would remove the possibility of fracturing the formation at the shoe, thus removing this "safety". It would also mean that APB would affect this annulus. The resulting differential pressures are shown in Figure 4.8. As expected, for the 13 5/8", the APB case caused a load more like collapse than the burst load experienced if the TOC was below the previous shoe. For the 16", it was opposite, resulting in a worse burst load. For the 16" APB became the worst load for the section (pressure test and GK before). The resulting DF are found in Table 4.14. The same pipes could be used, as the DF were above their limits.

### 5.2.3.3 Tieback Running Fluid

The fluid density for running the tieback was set to 1.749 sg, which was the density used when drilling the reservoir section. This gave overbalance to reservoir pressure. One option may be to run the tieback in a lighter fluid. This would decrease the external pressure on the tieback, and thus reducing the collapse forces. However, this would also increase the differential pressure from the Tubing Leak load. The requirements mention that "Running tieback string in light fluid is only allowed.. if .. no HC bearing formation shall be exposed behind the production liner." However, the most conservative is running the tieback in overbalance, using the 1.749 sg for this case. Table 4.15 shows the resulting

DFs. Figure 4.9 shows a graphical representation of this. As expected, it was seen that the burst-DF decreased and the collapse-DF increased. The lower density outside the tieback causes less resistance for burst loads, thus lowering the DF. The opposite is valid for collapse, as the lower density provides less pressure externally, thus a higher DF. The density of the packer fluid will also impact the resulting loads. Higher density would approach the original simulations with the heavier mud, yielding a higher collapse load. The opposite would be valid for a lower density.

#### 5.2.3.4 The Effect of Triaxial Hoop

In the section for pipe specifications there is a column called triaxial hoop. This is pre-set to 87.5 in the Statoil database. The triaxial SF and the pipe limit for triaxial stress are calculated by the Von Mises equation (Eq. A.7). In addition, an API correction factor of 0.875 is included to included the effect of wall thickness in reality will be less than the nominal wall thickness. Since this already is included, the Triaxial Hoop must be set to 100. If this is not done, the real SF would be as follows: Triaxial SF/0.875. In short, Statoil has specified the minimum triaxial SF=1.25. If triaxial hoop=0.875, the real triaxial SF =  $1.25/0.875 = 1.43$ , thus increasing the demands for the well to unnecessary levels. Table 4.16 shows the results from the sensitivity analysis. Figure 4.10 shows a graphical representation of this. It shows that the triaxial-DF will become to low when using 87.5.

#### 5.2.3.5 Squeezing Salt

As expected the effect of the salt formation was only seen on the collapse loads. A small change in DF was also seen in the triaxial-DF (0.09%). This change was expected to be slightly larger. The reason for this small effect is likely do to the equations behind triaxial analysis (Eq. A.7). Thus, with no change in the other stresses, the resulting triaxial effect will become small.

As seen in Table 4.17, the effect is substantial and will impact the well design. The salt formation is added as formation description in WellCat. A study should be done, where the salt should be implemented as a custom load. This would verify WellCats interpretation of the salt formation. Figure D.48 in Appendix D shows the resulting differential pressures.

#### 5.2.3.6 WT versus Yield Strength

Table 4.18 to 4.21 shows the calculated wall thickness for each scenario, presented for the 13 5/8" and the 9 7/8". Two observations were made; (1) the collapse loads required the highest wall thickness when compared to burst, (2) higher yield strength gave lower demand for wall thickness. This was expected based on the formulas used in the MatCad script used by Statoil. Figure 5.1 shows the wall thickness calculations for the case study. This clearly shows the two observations mentioned above. Higher grade (yield strength) would therefore result in higher clearance. As clearance often is a problem in deepwater wells with many casings, this is an important parameter.

### 5.2.3.7 Friction Factors in WellPlan

As seen in Table 4.22 and Figure 4.12, the choice of friction factors will be an important choice when doing simulations for these deepwater ERD wells. The factors will be important for simulating how long the reservoir section could be drilled. Discussion with Alasdair Fleming at Lyngaas TMC have led to the recommendation on friction factors should be between 0.25 and 0.28 for casings and 0.30 and 0.35 for OH. This is based on his experience with similar wells and simulation results versus actual data from drilling.

## 5.3 Design Requirements

As one of the goals of this thesis was to look at the two different requirements, a short evaluation of the process will follow. In addition, the requirements for the NCS is easily misinterpreted. A clarification will therefore be needed.

### 5.3.1 Global vs. GoM

Two different technical requirements exist for casing design; one valid on a global basis, and one valid in the GoM. As the water depth in the GoM are mainly deep water (ref. Figure E.1), these requirements are specially developed for these environments. While the global document “*applies to both development and exploration purpose wells, on and off-shore on a global basis*”. Shallow water clearly present different circumstances for casing design than deep water. Using the same requirement for them is therefore assumed to create a bad basis for the deepwater design. Evaluating the requirements and making a new document, specially designed for deepwater wells, is therefore recommended. An example from the requirements is given in the following section.

#### 5.3.1.1 Section Design Pressure

The requirements for determining the section design pressure vary depending on whether the well is located on the NCS or in the GoM. In the GoM requirements for PT, the following is stated: “*Casing extending to the wellhead: test to 70 % of the minimum burst pressure rating of the pipe, taking into account the differential already in place; it shall suffice for verifying the casing/liner installation. Liners: Test to the maximum of section design pressure or maximum expected leak-off test/formation integrity test*”.

In the requirements for the “global basis”: “*Specify a test pressure that produces an internal differential pressure equal to section design pressure at well head level or liner hanger level...Differential pressure should at all depths below well head or liner hanger be equal to or higher than any other differential pressure in order to qualify the string*”.

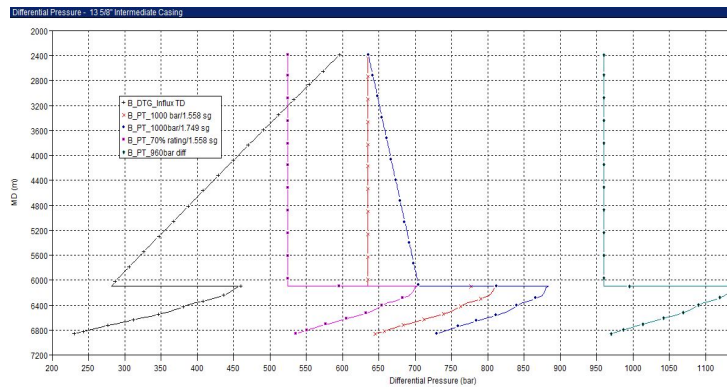
Section Design Pressure is defined as: “*the highest pressure expected to be seen at the wellhead. This is maximum injection pressure or shut-in wellhead pressure plus a margin that will allow killing the well by bull-heading*”.

The phrase “*internal differential pressure*” creates some confusion for the reader, thus increasing the threshold for setting up the simulations in the right way. A pressure test that produce a differential pressure equal to the highest internal pressure seen from worst case, would create an over-dimensioned test, as well as immense loads in the well. In a



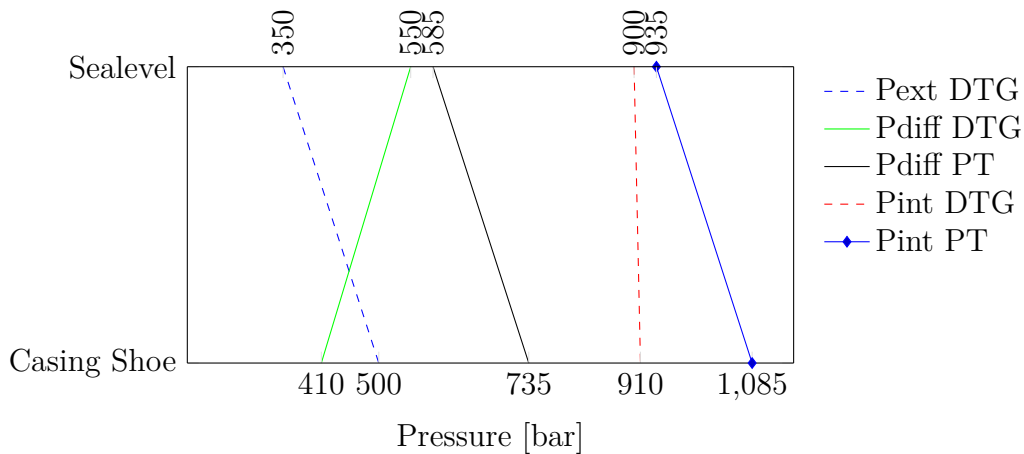
well with shallow water above, the contribution from the external pressure would be small, and thus the differential pressure would be close to the internal maximum. However, for deepwater wells, the hydrostatic pressure induced by the high water column will produce a external pressure that needs to be included.

Figure 5.5 shows the differential pressure for several interpretations of the pressure test. It shows that the two pressure tests based on the given differential pressure (560 bar from DTG), produce differential pressures always higher than the differential pressures for the DTG. They also include the 35 bar margin at the WH. The PT that is based on the GoM requirements (70 % of burst rating) shows that the differential pressure does not cover the Pdiff from DTG at all depths. According to the global version, this would disqualify the test. The last option added is the interpretation of having a pressure test that produces a differential pressure equal to the internal pressure. As seen, this is substantially higher than the load seen by the DTG. This would over-dimension the requirements for burst rating. Pore pressure in open hole was activated for the pressure test. This is the reason for the break in the straight line trend seen in the top. An example is given below with the intention of clarifying how the pressure test simulations should be set up.



**Figure 5.5:** Pressure test using 70% of burst rating (WellCat)

Shut-in wellhead pressure (SIWHP): 900 bar (Red dashed line)  
 Annulus wellhead pressure (AWHP): 350 bar (Blue dashed line)  
 Differential pressure, displaced well to gas:  $900 - 350 = 550\text{bar@WH}$  (Green line)  
 Test differential pressure:  $550 + 35 = 585\text{bar @ WH}$  (Black line)  
 Test pressure: 935 bar (Blue line)



**Figure 5.6:** Section Design Pressure - Example

The displaced well to gas scenario are plotted with dashed lines (red-internal, blue-external), and the resulting differential pressure as the green line, with 550 bar at WH and 410 bar at casing shoe. To meet the demand of bullheading margin, the differential pressure at WH must be  $550 + 35 = 585\text{bar}$  from the pressure test. The differential pressure from the pressure test is shown in the black line. The test fluid density in the example is set to heavier than the fluid present in the annulus, thus yielding a non-constant differential pressure. The internal pressure seen at the WH could be 935 bar from the PT (blue line).

As mentioned, a PT will give different loads down the well depending on which density is used; lighter fluid will give lower pressures down the well, thus lower loads. Higher fluids will give higher pressure down the well, thus higher loads.

### 5.3.2 Design Factors

Safety Factors represent a convenient method for comparing the rating of the pipe with the actual loads. Having a SF equal or higher 1 should therefore mean that the pipe will hold against the loads. WellCat calculates the the minimum safety factor for each pipe. These are called design factors (DF) in this thesis. The assumptions made for these to be valid are that the loads are fully defined and that the manufactured pipe behaves according to the specifications given by the vendor. These uncertainties are incorporated through the higher-than-one SF.

#### 5.3.2.1 Burst

As mentioned in Chapter 3.1.4 and Appendix A.1, the burst rating is based on API calculations. This involves degrading the the rating by a factor of 0.875 (12.5%). This allows for grinding out of tubing defects. Some pipes have a higher tolerance (from 0% to 10%). If pipe of this kind is used, the burst rating would be higher. This could then be used where higher burst ratings are required.

The hoop stress of the inner wall forms the basis for the API formula. (Ref Section A.1). As this assumes a slenderness ratio much greater than 1, this will yield conservative results. This is acknowledged by Adams et al. (2003), Payne (2001) and Klever and Tamano (2006). The formula also assumes that the failure occurs at the yield point. This is conservative, especially for low-grade tubulars. (Bellarby, 2009)

The design factors for burst were over-dimensioned for most of the sensitivities in this thesis. This was the result from the high collapse loads, which demanded higher wall thickness than what the burst loads required.

#### 5.3.2.2 Collapse

According to Adams et al. (2003) the API collapse formulas has long been recognized to be conservative for modern pipe. This has lead to a revision and modernization of the formulas (Payne, 2001). These new formulas include the effects of ovality, eccentricity and residual stress directly into the calculations. The API 5C3 formulas used in this thesis include a conservatism reflected in low collapse design factors or high demands for wall thickness to handle the collapse loads with the current factor.

Existing collapse formulations are the API 5C3, Timoshenko Model and Tamano Model. They are described in Appendix A.2. The basis for the API 5C3 formulas is the regression equation fitting 2488 tests (from 1960 and older), called *plastic collapse*. This formula was augmented with an elastic collapse formula for thin-walled pipe (high  $D/t$ ) and a yield collapse formula for thick-walled pipe (low  $D/t$ ). (Payne, 2001)

The fact that the tests are from 1960 and older and based on the conclusions made by Adams et al. (2003), it is assumed that the required collapse ratings found in this thesis are to conservative. This leads to a line of results; higher wall thickness, higher weight, higher price. In addition, the API approach is not valid for high-collapse pipes. As these HC pipes may be a good way of dealing with the high loads in deepwater ERD wells, this has to be re-evaluated with the new revised formulas. The Timoshenko and the Tamano model were not used in this thesis. As the Tamano model includes other aspects of collapse, the collapse ratings should be evaluated with this model and compared with the new API revision.

## 5.4 Optimization

Optimization for the successful drilling and completions of the well centers around casing and tubing design. Adequate room for running the casing forms the basis for choosing hole sizes. In addition, well circulation and cementing must be evaluated. Higher ROP, solids control costs and mud are some of the factors limiting excessive hole sizes. An important note to remember is that the combination of hole and casing size are not governed by the pipe OD, but by connection ODs.

As the industry keep pushing for “deeper” deepwater operations, the demands for optimizations becomes critical. Limited number of casings available to reach TD and limitations to run casings on available landing strings (due to excessive weigh), are factors that creates challenges. Higher pressure and HPHT-like deepwater wells further increase these issues. The need for more advanced design capabilities to address dimensional optimization of the tubulars are clear and urgent.

The need for pipe optimization have long been recognized (Payne (2001)). With the advances in inspection technology, new possibilities for inspecting and recording the specifications of a pipe is now possible. High speed ultrasonic inspection system are an example of such Technology. A more accurate base than the 12.5% deration would be to base the ratings on the minimum walls or averaged minimum walls from these UT inspections. According to Payne (2001), a more realistic deration would be 3%. This would yield approximately 10% improvement on internal pressure ratings.

Optimizing deepwater wells involves an extensive process, including a wide range of decisions. Formations, challenges, equipment access, weather/environment, all impose great varieties from place to place. All completions must therefore be evaluated individually. Figure E.2 on page A-53 shows a completion optimization scheme.

Properly executed cased holed frac packing appears to be more stable and long-lasting solution for sand control than openhole gravel packing, sand screens, or high-rate water-packing techniques (Figure 2.31). Frac packs require more complex fluids, larger volumes and higher pump rates than cases hole gravel packs. However, such equipment is easily

available in areas such as the GoM. The additional cost then becomes small in comparison to the benefit. Frac packs are therefore used as the primary cased hole sand control technique in these areas. (Furgier et al., 2007) Frac packs cannot be used in reservoir with a gas cap and often not in reservoirs with no effective barrier between the reservoir zones and the underlying aquifers. (Schlumberger, 2007)

### 5.4.1 Extending the Reservoir Section

A study on how long the reservoir section could be drilled would be very interesting. Unfortunately, the time for such a study was not found for this thesis. Some comments for future work are however presented below.

Several conditions must be investigated before a limit can be defined. Each of the following may result in a different TD:

1. Adequate WOB must be available.
2. Rig limitations must be kept in mind. Heavy drillpipe may cause large weights. 91 tons (200 kips) is set as a minimum overpull margin for GoM operations. Rig limitations also includes torque and pumping capacity.
3. Must be able to run the completion liner and the chosen completion solution.

In regards to the drilling operations, criteria for how far the section could be extended could be: the WOB, the overpull margin, torque, pump pressure and ECD. These could be evaluated for different string setup, e.g. the 6 5/8" DP may not be run below the WH. This is believed to decrease the possible TD substantially. When the limits to TD for these parameters are determined, a study on liner running for the resulting limits could be done.

For the cementing study, it would be interesting to investigate the the TD limits in regards to the following parameters: the rates, cement density, effect of additives/alternative cements (e.g. foam cementing).

## 5.5 Model Evaluation, Source of Errors and Future Work

### 5.5.1 Evaluation

#### 5.5.1.1 Well Design

Landmark's WellCat is a somewhat unintuitive software to work with. The loads must be defined from scratch and many of them are added as custom loads. In short, the quality of the designs depends on the knowledge of the well designer. Based on several sessions Lyngaas TMC, as well as thorough comparisons with Statoil models, it is believed that the model/simulation built in this thesis is accurately built. (Lyngaas TMC is a leading consulting company in Norway on WellCat simulations and well design.)

The results were consistent with what Statoil has found using a 10 3/4" liner (instead of a 9 7/8"). The resulting pressures for each section were also compared with Statoil and

found close to identical, with differences less +/- 2.5%. The study on the base case (the design Statoil was investigating) is shown in Table 4.2.

As these results were based on a HPHT well in deep water, with a reservoir pressure above 1,350 bar (20,000 psi), they are believed to be somewhat general for this type of well. The water depth was around 2,300 m, and the TD of the well was just below 8,000 mTVD. Requirements for gas lift was included, as well as two scenarios for the expectancy for hydrocarbons (expected and “no chance”). Some general conclusions may therefore be extracted from the work:

- Collapse will in general create the worst scenarios and thus the highest demand for well performance;
- Based on the resulting collapse loads, burst ratings will tend to be over-dimensioned;
- HC pipes should be evaluated.

The APB setup presents one of the limitations of the model built in this thesis. As the incremental pressures were found from the base case, these were not updated for the case study. The error was noticed when running the simulations for the TOC sensitivity (Section 4.3.1). An update for the case study was done to see the effect. It showed that a maximum of 13% difference could be seen in the incremental pressures. The changes caused by this were small and not limiting for the case study. It should however be remembered when evaluating the design. However, if the TOC for the 13 5/8” casing is inside the previous liner, this would have a larger effect, which could be limiting for the design. This was seen in the sensitivity study (Section 5.2.3.2). In short, if TOC lies below the previous shoe, the effect of the error would be neglectable. For TOC in previous shoe, a new study should be done.

Another disadvantage for the conclusion is that only two vendor’s were checked when looking for existing pipes. In addition, high-collapse pipes were not investigated.

Operations such as the frac job and possible injection operations were not included. This was due to high uncertainties in for the pressures and rates. Another reason was to keep the study as general as possible. If such operations are planned, additional load cases must be added to cover all scenarios.

Some data for were assumed, such as waiting-on-cement times (WOC) and circulations rates for the WellCat setup. According to Lyngaas TMC, these will not have large effects, and are thus believed to present neglectable differences if changed.

#### **5.5.1.2 Drillability Study**

The drillability study assumed no obstructions were met, as such analysis cannot take account of poor hole conditions. It was expected at that the larger OD items would be able to accept more WOB to get past the obstructions, however they also offer more susceptibility to being stopped by obstructions as they require more space to pass. All simulations were done in soft-string mode. This means that there were no bending stiffness and the string follows the center line of, and is in constant contact with, the wellbore. Stiff-string mode should be used on each case to make sure it is drillable. This includes tubular stiffness and does not assume the string to be in constant contact with the wellbore.

Cementing is believed to be the bottle neck for the 9 7/8" liner and the 13 5/8" casing. A limiting factor of the drillability study is obviously that not all sections were investigated. The effective flowrate that the annulus fluids will have is going to be affected by the free fall rates. So it may not be possible to completely remove ECD effects (density). The major component of ECD at low rates is the density (so when rates are turned down, it is an easy way of dropping the ECD). However, the job data presents options as annular clearance, rheology (cement is pretty thick stuff, but there are ways to reduce the ECD/freefall effect e.g. foam cement) and flow rates. If the freefall is causing the issues, then staging up the cement density is recommended. The last option would be to stage cement. The bottom would then be cemented first, and then the top of the casing/liner through ports. Theoretically, it is believed that it is possible to stage cement many zones, but in the same manner as a multi lateral, risk increases with each stage added, so normally not more than 2. Worst case scenario, the shoe depth has to be moved.

Archer's C-flex tool could be used to solve ECD problems caused by low clearance. Figure E.3 in Appendix E shows the tool. The cement job is then performed via an inner string stung into the float collar. While RIH with the inner string, the port collar is opened with the cementing tool. (Archer, n.d.) The cement will then return into open ports & annulus, as seen in the figure.

If gas lift is planned, the 13 5/8" casing would be a production barrier, with requirement to the cement behind casing. A thorough study on the cement job should be done. It is expected that small clearance would create problems here. Slick connections are therefore recommended.

Pipe specifications used were 90 % values - which means 81 % of the limit of elasticity of a new pipe ( $0.9 \cdot 0.9 = 0.81$ ). This is a bit conservative, but represents a methodology that is consistent with Ultra Deepwater operations. However, this is sometimes considered too conservative, and is in some cases left out. This would change the results in the study, with the result of longer wells. If left out, inspection routines and quality checking of equipment are paramount to the feasibility of drilling these wells. Improved pipe grades allowing stronger pipes for the same pipe weight would also likely improve the T&D situation.

The sensitivity study showed that the friction factors have a huge effect on the results, especially in the casing, where the side forces are highest. New techniques to improve this area could be using the Swivel master tool (from Tercel Oilfield products). This tool allows rotation of the drill string inside the casing whilst running strings which normally would not be rotated. A problem with the friction factors is that they only convert a percentage of the normal force to "resistance", and are very affected by the well trajectory. Moreover, friction coefficients is not really a single coefficient, but more a fudge factor that considers several factors.

### 5.5.2 Source of Errors

- Errors done in the load case setup in WellCat is a possibility. Small misprints in the setup may have been included. The WellCat setup is based on the Statoil requirement documents. Misprints may have been included unintentionally.
- Uncertainties in the input data. These data are based on data made available from Statoil. Any misprints or data not provided may have been included and counted as good data.
- The friction factors were assumed when simulating in WellPlan. The sensitivity study showed that these factors have a large effect on the drilling simulations. Simulations should therefore be compared with real drilling data to get friction factors that matches the real well.
- Any operations involving injection was not included. Plans involving injection calls for extra load cases in the simulations. These could create worse scenarios than simulated in this thesis.

### 5.5.3 Future Work

There are still some aspects that needs to be assessed before reaching the goal of a complete casing design for deepwater ERD wells. The WellCat simulations are somewhat complicated, and industry requirements are not fully updated for deepwater ERD wells. Enabling productions wells of this extreme character will involve the following steps:

- Make a tutorial for load case setup in WellCat.
- Collect vendor data for HC casings and implement these in the simulations.
- Use Timoshenko or Tamano model to investigate the differences in collapse ratings.
- An optimization algorithm/code could be made, taking the rating results from WellCat, then searching a database for possible pipes. This could include an optimizations of wall thickness versus yield strength and weigh.
- Making a Finite Element Model for the well. It is believed that the available software for well design is reaching their limit for accuracy when simulating on these extreme cases.
- An evaluation and upgrade of Statoil requirements would ease future work with deepwater ERD wells.
- Incorporate optimization for completion solutions/setup in such a way that one program could take the specified well and find the optimum completion solution for the user-specified restrictions.
- WellPlan simulations on the whole well.

# Chapter 6

## Conclusion

In this Master Thesis well design for deepwater ERD wells have been reviewed. The factors impacting the design have been investigated in WellCat and WellPlan. Gaps in the industry design envelope were tried identified, with some suggestions for improved performance. The results were compared with calculations based on existing theory on the subject. Based on the discussion in Chapter 5, the following conclusions can be made:

- Collapse loads will in general create the worst scenarios and thus the highest demand for well performance. This will cause the burst ratings to be over-dimensioned.
- New design requirements should be developed. These should be specific for deep waters and include a WellCat guide on how loads are set up. The loads given by the two existing requirement documents should be evaluated for deep water and checked if too conservative.
- For the given case study, new casing would have to be made to be able to withstand the high loads. These are currently not existing pipes on the market.
- A self-built WellCat model was made. Some parameters were varied to investigate the impact on the design, based on different requirements.
- A full study should be done on the drillability of the chosen design. A thorough study on cementing would be especially important.



# Bibliography

- Aadnøy, Bernt S. *Modern Well Design*. CRC Press/Balkema, second edition, 2010.
- A.J.and HessAdams, A.; Moore, P.W.; , and Payne, M.L. On the Calibration of Design Collapse Strengths for Quenched and Tempered Pipe. SPE 85112-PA. Presented at the *SPE Drilling & Completion*, volume 18, 2003. doi: <http://dx.doi.org/10.2118/85112-PA>.
- AkerSolutions, . Wirth TPK 2200 - High Pressure Mud Pump.  
<http://www.akersolutions.com/Documents/Drilling%20Technologies/Aker%20Wirth/Wirth%20TPK%202200.pdf> (accessed 4 May 2013).
- Archer, n.d. C-flex Tool.  
<http://www.archerwell.com> (accessed 29August13).
- Bellarby, Jonathan. *Well Completion Design*, volume 56. Elsevier B.V., 2009.
- Bennett, C.; Gilchrist, J.M.; Pitoni, E.; Burton, R.C.; Hodge, R.M.; Ali, S.A.; Dickerson, R.; Price-Smith, C., and Parlar, M. Design Methodology for Selection of Horizontal Open-Hole Sand Control Completions Supported by Field Case Histories. Paper SPE 65140-MS. Presented at the *SPE European Petroleum Conference*, Paris, France, 5-8 May 2000. doi: <http://dx.doi.org/10.2118/65140-MS>.
- Danilovic, D.; Maricic, V.K., and Ristic, I. A Selection Method of the Horizontal Wells Completion, 2006.  
<http://citeseerx.ist.psu.edu/viewdoc/download?doi=10.1.1.139.8480&rep=rep1&type=pdf> (accessed 3 September 2013).
- Dyson, W.Q. Dyson; Coludrovich, E.; Creech, R.; Weldy, J.C.; Fruge, M., and Guidry, M. Best Completion Practices. Paper SPE 52810-MS. Presented at the *SPE/IADC Drilling Conference*, Amsterdam, Netherlands, 9-11 March 1999. doi: <http://dx.doi.org/10.2118/52810-MS>.
- Furgier, J.N.; Lavoix, F., and Lemesnager, F. Pushing The Limits Of Frac-Pack Operating Envelope. Presented at the *European Formation Damage Conferance*, Scheveningen, The Netherlands, 30 May-1 June 2007. doi: <http://dx.doi.org/10.2118/107699-MS>.
- Hachana, Yassine. Subsea Trees, September 2012.  
<http://oilandgastechologies.wordpress.com/2012/08/09/subsea-trees/> (accessed 30 September 2013).
- Halliburton, . WellCat<sup>TM</sup>Suite Well Operations Software, a.  
<https://www.landmarksoftware.com/Pages/WELLCAT.aspx> (accessed 2 October 2013).
- Halliburton, . Landmark Help File, b.
- Halliburton, n.d. COMPASS<sup>TM</sup>Directional Well Planning Software, c.  
<http://www.halliburton.com/ps/Default.aspx?navid=916&pageid=820&prodid=MSE%3a%3a1055449609071102> (accessed 28 August 2013).

- Halliburton, n.d. Wellplan™ Suite Well Operations Software, d.  
<http://www.halliburton.com/ps/Default.aspx?navid=923&pageid=891> (accessed 28 August 2013).
- King, G.E.; Wildt, P.J., and O'Connell, E. Sand Control Completion Reliability and Failure Rate Comparison With a Multi-Thousand Well Database. Paper SPE 84262-MS. Presented at the *SPE Annual Technical Conference and Exhibition*, Denver, Colorado, 5-8 October 2003. doi: <http://dx.doi.org/10.2118/84262-MS>.
- Klever, F.J. and Tamano, T. A New OCTG Strength Equation for Collapse Under Combined Loads. SPE 90904-PA. Presented at the *SPE Drilling & Completion*, volume 21, September 2006. doi: <http://dx.doi.org/10.2118/90904-PA>.
- MaerskDrilling, n.d. Maersk Developer.  
<http://www.maerskdrilling.com/DrillingRigs/Semi-submersibles/Pages/MaerskDeveloper.aspxf> (accessed 16 February 2013).
- Maldonado, B.; McCaseland, M., and Arrazola, A. Extreme HP/HT Completions: Technology Challenges Facing Deep Gas Wells. Presented at the *SPE Annual Technical Conference and Exhibition*, The Woodlands, Texas, 17-19 May 2005. doi: <http://dx.doi.org/10.2118/97594-PT>.
- McSpadden, A.R. and Glover, S. Importance of Predicted Cementing Temperatures for Critical HP/HT Casing Design: Guidelines and Case Studies. Presented at the *SPE Annual Technical Conference and Exhibition*, Denver, Colorado, USA, 21-24 September 2008. doi: <http://dx.doi.org/10.2118/114928-MS>.
- Natural Gas, n.d. Well Completion.  
[http://www.naturalgas.org/naturalgas/well\\_completion.asp](http://www.naturalgas.org/naturalgas/well_completion.asp) (accessed 28 August 2013).
- Offshore Magazine, 2000. Drilling Muds for Deepwater: Hydrates and Rheology Problems, January 2000.  
<http://www.offshore-mag.com/articles/print/volume-60/issue-5/news/general-interest/drilling-muds-for-deepwater-hydrates-and-rheology-problems.html> (accessed 16 January 2013).
- Payne, M.L. Modernization of OCTG Performance and Design Standards. SPE 13053-MS. Presented at the *Offshore Technology Conference*, Houston, Texas, 30 April-3 May 2001. doi: <http://dx.doi.org/10.2118/13053-MS>.
- PetroWikiSPE, 2006. Completion Systems, 2006a.  
[http://petrowiki.org/PEH%3ACompletion\\_Systems](http://petrowiki.org/PEH%3ACompletion_Systems) (accessed 2 October 2013).
- PetroWikiSPE, 2006. Deepwater Drilling, 2006b.  
[http://petrowiki.org/Deepwater\\_drilling](http://petrowiki.org/Deepwater_drilling) (accessed 14 January 2013).
- Rae, P. and Di Lullo, G. Lightweight Cement Formulations for Deep Water Cementing: Fact and Fiction. SPE 91002. Presented at the *SPE Annual Technical Conference and Exhibition*, Houston, Texas, 26-29 September 2004. doi: <http://dx.doi.org/10.2118/91002-MS>.
- Ravi, K.; Biezen, E.N.; Lightford, S.C.; Hibbert, A., and Greaves, C. Deepwater Cementing Challenges. Paper SPE 56534. Presented at the *SPE Annual Technical Conference*

- and Exhibition*, Houston, Texas, 3-6 October 1999. doi: <http://dx.doi.org/10.2118/56534-MS>.
- Rigzone, n.d. Jack / St Malo Deepwater Oil Project, Gulf of Mexico, a. <http://www.offshore-technology.com/projects/jackstmalodeepwaterp/jackstmalodeepwaterp2.html> (accessed 15. December 2013).
- Rigzone, n.d. How Does Well Completion Work?, b. [http://www.rigzone.com/training/insight.asp?insight\\_id=326](http://www.rigzone.com/training/insight.asp?insight_id=326) (accessed 29August13).
- Rigzone, n.d. How Do Solid Expandable Tubulars Enhance Deep Well Value?, c. [http://www.rigzone.com/training/insight.asp?insight\\_id=326](http://www.rigzone.com/training/insight.asp?insight_id=326) (accessed 3October13).
- Rocha, L.A.S.; Andrade, R., and Soffried, K. How Water Depth Affects Extended Reach Drilling. Paper OTC 15326. Presented at the *Offshore Technology Conference*, Houston, Texas, U.S.A., 5-8 May 2003a. doi: <http://dx.doi.org/10.4043/15326-MS>.
- Rocha, L.A.S.; Junqueira, P., and Roque, J.L. Overcoming Deep and Ultra Deepwater Drilling Challenges. Paper OTC 15233. Presented at the *Offshore Technology Conference*, Houston, Texas, U.S.A., 5-8 May 2003b. doi: <http://dx.doi.org/10.4043/15233-MS>.
- Sangesland, Sigbjørn. Drilling and Completion of Subsea Wells. Lecture in TPG4200 - Subsea Underwater Production Systems, NTNU, Spring 2012, 2012.
- Schlumberger, . Frac Packing: Fracturing for Sand Control. *Middle East & Asia Reservoir Review*, (8), 2007. [http://www.slb.com/~media/Files/resources/mearr/num8/37\\_49.pdf](http://www.slb.com/~media/Files/resources/mearr/num8/37_49.pdf) (accessed 18 2013).
- Venhaus, D.E.; Blount, C.G.; Dowell, K.E.; Gantt, L.L.; Sarber, J.G., and A.J. and Rixse-Worthington, M. Overview of the Kuparuk CTD Program and Recent Record-Setting Operations. Paper SPE 100210-MS. Presented at the *SPE Coiled Tubing Conference & Exhibition*, The Woodlands, Texas, USA, 5-8 October4-5 April 2008. doi: <http://dx.doi.org/10.2118/100210-MS>.
- Vulcanization, n.d. Vulcanization. <http://www.princeton.edu/~achaney/tmve/wiki100k/docs/Vulcanization.html>.
- Walton, I.C.; Atwood, D.C.; Halleck, P.M., and Bianco, L.C.B. Perforating Unconsolidated Sands: An Experimental and Theoretical Investigation. *SPE Drilling & Completion*, 17(3), September 2002. doi: <http://dx.doi.org/10.2118/79041-PA>.
- Watson, P.A.; Iyoho, A.W.; Meize, R.A., and Kunning, J.R. Management Issues and Technical Experience in Deepwater and Ultra-Deepwater Drilling. Paper OTC 17119. Presented at the *Offshore Technology Conference*, Houston, Texas, U.S.A., 2-5 May 2005. doi: <http://dx.doi.org/10.4043/17119-MS>.
- Wetzel, R.J.; Mathis, S.; Ratterman, G., and Cade, R. Completion Selection Methodology for Optimum Reservoir Performance and Project Economics in Deepwater Applications. Paper SPE 56716-MS. Presented at the *SPE Annual Technical Conference and Exhibition*, Houston, Texas, 3-6 October 1999. doi: <http://dx.doi.org/10.2118/56716-MS>.



# Abbreviations

DGD	Dual-Gradient Drilling.
ECPs	External Casing Packers.
EDM	Engineer's Data Model™.
EMW	Equivalent Mud Weight.
ERW	Extended Reach Wells.
GoM	Gulf of Mexico.
HPHT	High Pressure High Temperature.
HRWP	High-Rate Water Pack.
LWSA	Lightweight Solid Additives.
MPD	Managed Pressure Drilling.
MSL	Mean Sea Level.
OOIP	Original Oil in Place.
PPS	Pre-Packed Screens.
PT	Pressure Test.
SAS	Standalone Screens.
SDP	Section Design Pressure.
SF	Safety Factor.
SSVs	Subsurface Safety Valves.
T&D	Torque and Drag.
TAML	Technology Advancement of MultiLaterals.
TTRD	Through-Tubing Rotary Drilling.
WOC	Wating on Cement.
WWS	Wire-Wrapped Screens.



# Nomenclature

$A_x$	Unit area.
$C_T$	Coefficient of thermal expansion.
$D/t$	The slenderness ratio (OD-to-thickness (D/t) ratio).
$D_{Hanger}$	Hanger Depth [TVD].
$D_{Wellhead}$	Wellhead Depth [TVD].
$D$	Tubing outside diameter.
$EMW_{kickintensity}$	Equivalent mud weigh kick intensity.
$F_{a,max}$	Axial strength.
$F$	Force.
$L$	Unit length.
$P_e$	Equivalent External Pressure.
$P_i$	Internal Pressure.
$P_o$	External Pressure.
$P_{Pump}$	Pump Pressure for Pressure Test.
$P_{bh}$	Bottomhole pressure.
$P_{i,max}$	Maximum Shut-in Wellhead Pressure.
$P_{test@WH}$	Test Pressure at Wellhead.
$TVD_{MudLevel}$	TVD for mud after Drop.
$TVD_{influxdepth}$	True vertical depth of influx.
$TVD_{pore}$	TVD for given Depth.
$Tol$	Wall thickness tolerance correction (fraction).
$Y_p$	Yield strength.
$Y_p$	Yield stress.
$\Delta L_T$	Expansion.
$\Delta L$	Length change.
$\Delta T$	Average change in tempeprature.

---

$\rho_{mud}$	Mud density.
$\rho_{pore}$	Pore Pressure Density [sg].
$\rho$	Test Fluid Density.
$\sigma_a$	Axial stress.
$\sigma_r$	Radial stress.
$\sigma_t$	Tangential stress.
$\sigma_{yield}$	Yield strength.
$\sigma$	Stress.
$\varepsilon$	Strain.
$g$	Gravity constant.
$h_{muddrop}$	Height of Mud Drop [m].
$p_b$	Burst rating.
$p_e$	Elastic collapse rating.
$t$	Nominal tubing thickness.



# List of Figures

## Chapter 2

2.1	Temperature versus depth in deep water. (Rae and Di Lullo, 2004)	3
2.2	Pressure window (Rocha et al., 2003b)	4
2.3	Horizontal and vertical Christmas tree. (Hachana, 2012)	8
2.4	Downhole safety valves. (Bellarby, 2009)	9
2.5	Typical hydraulic set production packer. (Bellarby, 2009)	10
2.6	Packer configurations. (Bellarby, 2009)	10
2.7	Nipple profile and lock. (Bellarby, 2009)	11
2.8	Mandrel and gauge. (Bellarby, 2009)	12
2.9	Upper completion methods. (Bellarby, 2009)	13
2.10	Reservoir completion methods. (Bellarby, 2009)	13
2.11	Pre-slotted liner. (Bellarby, 2009)	15
2.12	External casing packer. (Bellarby, 2009)	16
2.13	Swellable elastomer packer. (Bellarby, 2009)	16
2.14	Perforation. (Bellarby, 2009)	17
2.15	Two type of screens. (Bellarby, 2009)	19
2.16	Premium Screens (Bellarby, 2009)	19
2.17	Openhole gravel pack (Schlumberger, 2007)	20
2.18	Circulating pack sequence. (Bellarby, 2009)	21
2.19	Alternate path gravel packing with shunts. (Bellarby, 2009)	22
2.20	Cased hole gravel pack overview.	23
2.21	Expandable screens (Bellarby, 2009)	24
2.22	Woven mesh for expandable screens. (Bellarby, 2009)	25
2.23	Expansion methods. (Bellarby, 2009)	25
2.24	TAML Level 1, 2 and 3. (PetroWiki SPE, 2006, a)	27
2.25	TAML Level 4, 5 and 6. (PetroWiki SPE, 2006, a)	28
2.26	Parallel-string dual-zone completion. (PetroWiki SPE, 2006, a)	29
2.27	Multipurpose completions.	29
2.28	Completing an underbalance drilled well. (Bellarby, 2009)	30
2.29	Typical deepwater setup in the GoM, below 20,000 ft. (Rigzone, n.d., c)	31
2.30	Completion options. (Schlumberger, 2007)	33
2.31	Life comparison for different sand control options. (Schlumberger, 2007)	34

## Chapter 3

3.1	Stress-strain relationship. (Bellarby, 2009)	36
3.2	Collapse pressure as a function of slenderness. (Bellarby, 2009)	38
3.3	Stress components of triaxial analysis. (Bellarby, 2009)	39
3.4	APB situations: may/may not cause casing failure. (Aadnøy, 2010)	46

## Chapter 4

4.1	Design Factors Case Study - Burst & Collapse	50
4.2	Design Factors Case Study - Axial & Triaxial	50
4.3	Torque - Running 5 1/2" Liner (WellPlan)	51
4.4	Maximum Internal Pressure - Sensitivities	52

4.5	Minimum and Maximum Differential Pressure - Sensitivities . . . . .	52
4.6	Design Factors Sensitivity - Burst & Collapse . . . . .	53
4.7	Design Factors Sensitivity - Axial & Triaxial . . . . .	53
4.8	Differential pressure for APB - TOC in 16" shoe versus below shoe. . . . .	57
4.9	Design Factors - Running Tieback in Packer Fluid . . . . .	57
4.10	Triaxial Design Factors - Effect of triaxial hoop . . . . .	58
4.11	Design Factors - With/Without Salt Formations . . . . .	59
4.12	Sensitivity on friction factors when tripping in (WellPlan) . . . . .	60
<b>Chapter 5</b>		
5.1	Wall Thickness - Calculation Results Case Study . . . . .	62
5.2	Design Factors Case Study - Burst & Collapse . . . . .	63
5.3	Maximum Internal Pressure - Sensitivities . . . . .	65
5.4	Minimum and Maximum Differential Pressure - Sensitivities . . . . .	65
5.5	Pressure test using 70% of burst rating (WellCat) . . . . .	69
5.6	Section Design Pressure - Example . . . . .	69
<b>Appendix B</b>		
B.1	3D view of the base case well trajectory (Compass) . . . . .	A-10
B.2	Well schematic - Basecase (WellCat) . . . . .	A-11
B.3	Setup in the Drill Module (WellCat) . . . . .	A-11
B.4	The BHA assembly (WellPlan) . . . . .	A-13
B.5	Drilling Setup in WellPlan (WellPlan) . . . . .	A-13
B.6	Transport Analysis Data - Running 5 1/2" Liner (WellPlan) . . . . .	A-13
B.7	Fluid settings - 1.749 sg mud used for drilling 8 1/2" hole (WellPlan) . . . . .	A-14
<b>Appendix C</b>		
C.1	Gas Kick setup - 22in. (WellCat) . . . . .	A-23
C.2	Displacement to Gas setup - 22in. (WellCat) . . . . .	A-23
C.3	Well Schematic - Annulus Description . . . . .	A-24
C.4	Displacement to Gas setup - 18in. (WellCat) . . . . .	A-24
C.5	Displacement to Gas setup - 16in. (WellCat) . . . . .	A-25
C.6	Differential pressure for GK and Pressure Test . . . . .	A-25
C.7	Displacement to Gas setup - 13 5/8in. (WellCat) . . . . .	A-25
C.8	Full Evacuation setup - 13 5/8in. (WellCat) . . . . .	A-26
C.9	Displacement to Gas setup - 9 7/8in. (WellCat) . . . . .	A-26
C.10	Tubing Leak setup - 9 7/8in. (WellCat) . . . . .	A-26
C.11	Full Evacuation setup - 9 7/8in. (WellCat) . . . . .	A-27
C.12	Tubing Leak setup - 9 7/8in tieback. (WellCat) . . . . .	A-27
C.13	Full Evacuation setup - 9 7/8in tieback. (WellCat) . . . . .	A-27
C.14	DTG setup - 5 1/2in. (WellCat) . . . . .	A-28
C.15	Tubing Leak setup - 5 1/2in. (WellCat) . . . . .	A-28
C.16	Full Evacuation setup - 5 1/2in. (WellCat) . . . . .	A-28

**Appendix D**

D.1	Internal and differential pressure for Gas Kick - 22in. (WellCat)	A-29
D.2	Internal and differential pressure for DTG - 22in. (WellCat)	A-30
D.3	Differential pressure for Lost Returns and Cementing - 22in. (WellCat)	A-30
D.4	Internal and differential pressure for Gas Kick - 18in. (WellCat)	A-31
D.5	Internal and differential pressure for DTG - 18in. (WellCat)	A-32
D.6	Differential pressure for Lost Returns and Cementing - 18in. (WellCat)	A-32
D.7	Internal and differential pressure for Gas Kick - 16in. (WellCat)	A-33
D.8	Internal and differential pressure for DTG - 16in. (WellCat)	A-33
D.9	Differential pressure for Lost Returns and Cementing - 16in. (WellCat)	A-34
D.10	Internal and differential pressure for DTG - 13 5/8in. (WellCat)	A-34
D.11	Differential pressure: Lost Returns versus Full Evacuation	A-35
D.12	Internal and differential pressure for DTG - 9 7/8in. (WellCat)	A-36
D.13	Differential pressure: Above/below packer versus Full Evacuation	A-36
D.14	Internal and differential pressure for TL - 9 7/8in tieback. (WellCat)	A-37
D.15	Differential pressure: APB versus Full Evacuation	A-38
D.16	Internal and differential pressure for DTG - 5 1/2in tieback. (WellCat)	A-38
D.17	Differential pressure: Lost Returns versus Full Evacuation	A-39
D.18	Internal and differential pressure for Gas Kick - 22in. (WellCat)	A-39
D.19	Internal and differential pressure for DTG - 22in. (WellCat)	A-40
D.20	Differential pressure for Lost Returns and Cementing - 22in. (WellCat)	A-40
D.21	Internal and differential pressure for Gas Kick - 18in. (WellCat)	A-40
D.22	Internal and differential pressure for DTG - 18in. (WellCat)	A-41
D.23	Differential pressure for Lost Returns and Cementing - 18in. (WellCat)	A-41
D.24	Internal and differential pressure for Gas Kick - 16in. (WellCat)	A-41
D.25	Internal and differential pressure for DTG - 16in. (WellCat)	A-42
D.26	Differential pressure for Lost Returns and Cementing - 16in. (WellCat)	A-42
D.27	Internal and differential pressure for DTG - 13 5/8in. (WellCat)	A-42
D.28	Differential pressure: Lost Returns versus Full Evacuation	A-43
D.29	Internal and differential pressure for DTG - 10 3/4in. (WellCat)	A-43
D.30	Differential pressure: Above/below packer versus Full Evacuation	A-43
D.31	Internal and differential pressure for TL - 10 3/4in tieback. (WellCat)	A-44
D.32	Differential pressure: APB versus Full Evacuation	A-44
D.33	Internal and differential pressure for DTG - 5 1/2in tieback. (WellCat)	A-44
D.34	Including Gas Lift - Full Evacuation - 5 1/2".	A-45
D.35	Fluid temperature from production (WellCat)	A-45
D.36	Fluid pressure from production (WellCat)	A-45
D.37	Hook Load - Drilling 8 1/2" Hole (WellPlan)	A-46
D.38	Tension - Drilling 8 1/2" Hole (WellPlan)	A-46
D.39	Von Mises Stress - Drilling 8 1/2" Hole (WellPlan)	A-46
D.40	Torque - Drilling 8 1/2" Hole (WellPlan)	A-47
D.41	Minimum Flow Rate - Drilling 8 1/2" Hole (WellPlan)	A-47
D.42	ECD using 1650lpm - Drilling 8 1/2" Hole (WellPlan)	A-47
D.43	Hook Load - Running 5 1/2" Liner (WellPlan)	A-48
D.44	Tension - Running 5 1/2" Liner (WellPlan)	A-48
D.45	ECD using 1800lpm - Running 5 1/2" Liner (WellPlan)	A-48
D.46	Resulting Rates - Cementing 5 1/2" Liner (WellPlan)	A-49

D.47 ECD - Cementing 5 1/2" Liner (WellPlan) . . . . .	A-49
D.48 Differential pressure 16" - With/without salt formations . . . . .	A-49

**Appendix E**

E.1 Water depths in the GoM. (Rigzone, n.d., a) . . . . .	A-51
E.2 Decision sheet for optimal completions. (Dyson et al., 1999) . . . . .	A-53
E.3 C-flex tool. (Archer, n.d.) . . . . .	A-54

# List of Tables

## Chapter 2

2.1 Well Classification (Rocha et al., 2003a) . . . . .	5
---	---

## Chapter 3

3.1 NORSOK completion design factors. (Bellarby, 2009) . . . . .	40
--	----

## Chapter 4

4.1 Final Well Design - Case Study (No HC + Gas lift) . . . . .	48
4.2 Final Well Design - Base Case (No HC + Gas lift) . . . . .	48
4.3 Section Pressure Summary - Case Study (No HC + Gas lift) . . . . .	49
4.4 Design Factors - Case Study (No HC + Gas lift) . . . . .	49
4.5 Final Well Design - Sensitivity (No HC) . . . . .	54
4.6 Final Well Design - Sensitivity (HC) . . . . .	54
4.7 Final Well Design - Sensitivity (HC + Gas lift) . . . . .	54
4.8 Section Pressure Summary - Sensitivity (No HC) . . . . .	55
4.9 Section Pressure Summary - Sensitivity (HC) . . . . .	55
4.10 Section Pressure Summary - Sensitivity (HC + Gas lift) . . . . .	55
4.11 Design Factors - Sensitivity (No HC) . . . . .	56
4.12 Design Factors - Sensitivity (HC) . . . . .	56
4.13 Design Factors - Sensitivity (HC + Gas lift) . . . . .	56
4.14 Design Factors - TOC in 16" shoe versus below the shoe . . . . .	57
4.15 Design Factors - Running Tieback in Packer Fluid (1.318 sg) . . . . .	57
4.16 Design Factors - Effect of Triaxial Hoop . . . . .	58
4.17 Design Factors - With/Without Salt Formations . . . . .	58
4.18 Wall Thickness Calculations - Case Study (No HC + Gas lift) . . . . .	59
4.19 Wall Thickness Calculations - Sensitivity ((A) NoHC) . . . . .	59
4.20 Wall Thickness Calculations - Sensitivity ((B) HC) . . . . .	59
4.21 Wall Thickness Calculations - Sensitivity ((D) HC+Gas Lift) . . . . .	60
4.22 Effect of different friction factors on torque and drag . . . . .	60

## Appendix A

A.1 Collapse modes. (Bellarby, 2009) . . . . .	A-1
A.2 Plastic collapse factors. (Bellarby, 2009) . . . . .	A-2
A.3 Transitional collapse factors. (Bellarby, 2009) . . . . .	A-2
A.4 Pressure Test Data - No HC (A) . . . . .	A-5
A.5 Pressure Test Data - HC (B) . . . . .	A-6
A.6 Mud Drop Calculations . . . . .	A-7

## Appendix B

B.1 Technical data for the Wirth TPK pumps (AkerSolutions) . . . . .	A-8
B.2 Maersk Developer rig specifications (MaerskDrilling) . . . . .	A-9
B.3 Wellpath setup for the basecase (Compass) . . . . .	A-10
B.4 Well configuration - Basecase (WellCat) . . . . .	A-10
B.5 Hole section - Drilling 8 1/2" (WellPlan) . . . . .	A-12
B.6 BHA specifications - Drilling 8 1/2" (WellPlan) . . . . .	A-12
B.7 Running String - Running 5 1/2" Liner (WellPlan) . . . . .	A-13

B.8 Job Data - Cementing 5 1/2" Liner (WellPlan) . . . . . A-14

**Appendix E**

E.1 Examples of barrier systems through the life of the well. (Bellarby, 2009) A-50  
E.2 API grades and strengths from API 5CT(2005). (Bellarby, 2009) . . . . . A-51  
E.3 Alternate path versus circulating open hole gravel packs. (Bellarby, 2009) A-52

# Appendix A

## Stress Analysis Equations

### A.1 Burst

Barlow's equation (Equation 3.5) describes the burst rating. The wall thickness tolerance for API pipe is 0.875 (12.5% reduction). In comparison to collapse and axial failures, burst failures only requires a failure of a very small piece of the tubing. This means the burst rating is impacted by anything that affects the minimum wall thickness. (Bellarby, 2009)

$$p_b = Tol \left( \frac{2 \cdot Y_p \cdot t}{D} \right) \quad (\text{A.1})$$

Where:

$p_b$  = Burst rating

$Tol$  = Wall thickness tolerance correction (fraction)

$D$  = Tubing outside diameter (in.)

$t$  = Nominal tubing thickness (in.)

$Y_p$  = Yield strength (psi)

### A.2 Collapse

Four collapse modes are defined in the API Bulletin 5C3 (1999); elastic, transitional, plastic and yield strength. Each different mode have an associated formula. All of them are empirical in origin. The slenderness ratio (OD-to-thickness (D/t) ratio) defines the selection of the appropriate mode. Each mode has an associated formula. Different values for collapse modes are shown in Table A.1. (Bellarby, 2009)

**Table A.1:** Collapse modes. (Bellarby, 2009)

Grade (ksi)	Elastic Collapse (D/t)	Transitional Collapse (D/t)	Plastic Collapse (D/t)	Yield Collapse (D/t)
40	> 42.64	27.01–42.64	16.40–27.01	< 16.40
55	> 37.21	25.01–37.21	14.81–25.01	< 14.81
80	> 31.02	22.47–31.02	13.38–22.47	< 13.38
90	> 29.18	21.69–29.18	13.01–21.69	< 13.01
95	> 28.36	21.33–28.36	12.85–21.33	< 12.85
110	> 26.22	20.41–26.22	12.44–20.41	< 12.44
125	> 24.46	19.63–24.46	12.11–19.63	< 12.11
140	> 22.98	18.97–22.98	11.84–18.97	< 11.84
155	> 21.70	18.37–21.70	11.59–18.37	< 11.59

Elastic collapse:

$$p_e = \frac{46,95 \cdot 10^6}{(D/t)[(D/t) - 1]^2} \quad (\text{A.2})$$

Where:

$p_e$  = Elastic collapse rating

$D/t$  = The slenderness ratio (OD-to-thickness (D/t) ratio)

As the deformation is purely elastic, the yield stress of the tubing is irrelevant. Plastic collapse:

$$p_p = Y_p \left[ \frac{A}{D/t} - B \right] - C \quad (\text{A.3})$$

The values for A, B and C are supplied from API 5C3 via formula or from Table A.2.

**Table A.2:** Plastic collapse factors. (Bellarby, 2009)

Grade (ksi)	A	B	C
40	2.95	0.0465	754
55	2.991	0.0541	1206
80	3.071	0.0667	1955
90	3.106	0.0718	2254
95	3.124	0.0743	2404
110	3.181	0.0819	2852
125	3.239	0.0895	3301
140	3.297	0.0971	3751
155	3.356	0.1047	4204

Transitional collapse:

$$p_t = Y_p \left[ \frac{F}{D/t} - G \right] \quad (\text{A.4})$$

The values for F and G are also supplied from API 5C3 via formula or from Table A.3.

**Table A.3:** Transitional collapse factors. (Bellarby, 2009)

Grade (ksi)	F	G
40	2.063	0.0325
55	1.989	0.036
80	1.998	0.0434
90	2.017	0.0466
95	2.029	0.0482
110	2.053	0.0515
125	2.106	0.0582
140	2.146	0.0632
155	2.188	0.0683

Yield collapse:

$$p_y = 2Y_p \left[ \frac{(D/t) - 1}{((D/t)^2)} \right] \quad (\text{A.5})$$



The yield strength collapse formula represents the external pressure that generates a stress equivalent to the minimum yield stress on the inside wall of the tubing. (Bellarby, 2009)

There are further some complications that needs to be reviewed. For internal pressure and tension, the API derates collapse resistance. The internal pressure effect can be expressed through the following equation: (Bellarby, 2009)

$$p_e = p_o - \left(1 - \frac{2}{(D/t)}\right) \cdot p_i \quad (\text{A.6})$$

Where:

$P_e$  = Equivalent external pressure

$P_o$  = External pressure

$P_i$  = Internal pressure

Applying internal pressure can cause this equivalent pressure. The hydrostatic pressure increasing with depth could also cause this. Thus, even though the differential pressure could remain the same, the collapse load will be higher with depth. (Bellarby, 2009)

According to Adams et al. (2003) the API collapse formulas has long been recognized to be conservative for modern pipe. This has lead to a revision and modernization of the formulas (Payne, 2001). These new formulas include the effects of ovality, eccentricity and residual stress directly into the calculations. The API 5C3 formulas used in this thesis include a conservatism reflected in low collapse design factors. This will be discussed in Chapter 5.

Due to this conservatism, it results in unnecessarily expensive casings in high-pressure wells as found in deep waters. This is especially valid for casings. To close the gap between the API 5C3 and the revision done in 2008 (Payne (2001)), high collapse (HC) casings can be used. The HC resistance is provided by several methods:

1. Reduction in wall thickness tolerances;
2. Special metallurgies or control of yield stress variations;
3. Reduction in eccentricity and ovality;
4. Heat treatment or reduction in residual stresses;
5. Use of hot rotary straightening;
6. Alternative formulas for collapse.

Existing collapse formulations are the API 5C3, Timoshenko Model and Tamano Model. The basis for the API 5C3 formulas is the regression equation fitting 2488 tests, called *plastic collapse*. This formula was augmented with an elastic collapse formula for thin-walled pipe (high D/t) and a yield collapse formula for thick-walled pipe (low D/t). The Timoshenko model describes collapse of a thin-walled, elastic pipe with an initial ovality. In this model, the detrimental effect of ovality is greatest in the transition range. It does not describe the effect of combined loading. The Tamano Model, like the Timoshenko model, shows the greatest detrimental effect of imperfections to be in the transition range.

However, Tamano's model does not converge to yield collapse or elastic collapse for extreme values of the D/t range. (Klever and Tamano, 2006) Equations for the mentioned models can be found the work of Klever and Tamano (2006). An evaluation of the models were done by Adams et al. (2003). Below are the main conclusions made on the limitations of the existing approach (API 5C3):

- The collapse-test data which the equations are based on are now rather old (from 1960 and older). Modern production practices have improved considerably. The equations may therefore not represent the performance of modern tubulars.
- Short specimens were used for the majority of the collapse test. This is now known to overestimate the collapse strength of real pipe.
- The equations result in a widely varying margin between the ultimate and design collapse strengths over the D/t range for well tubulars and, thus, also in predicted failure probability.
- The specimens were manufactured using a wide range of production methods. Subsequent work has demonstrated that both straightening and heat treatment have a significant effect on the collapse strength.
- The API approach can not accommodate non-API grades, such as high-collapse (HC) pipe.

For yield failure, the API 5C3 underestimates the collapse strength because failure does not occur until "*the elastoplastic boundary has penetrated some way through the wall thickness*". The Tamano model includes this effect. (Adams et al., 2003)

### A.3 Triaxial Analysis

The most used criterion for yielding is the Von Mises (VME) yield condition (Huber-Hencky-Mises). This is based on the maximum distortion energy theory. Yielding will occur if the VME stress exceeds the yield stress. The VME stress is not a vector addition of the three stresses, but a combination of them. A simplified equation of the Von Mises equation is presented below (Bellarby, 2009) :

$$(\sigma_a - \sigma_r)^2 + (\sigma_a - \sigma_t)^2 + (\sigma_r - \sigma_t)^2 = 2\sigma_{yield}^2 \quad (A.7)$$

Where:

- $\sigma_{yield}$  = Yield strength
- $\sigma_a$  = Axial stress
- $\sigma_r$  = Radial stress
- $\sigma_t$  = Tangential stress

## A.4 Equations and Calculations

### A.4.1 Calculating Pump Pressure for Pressure Test

The equations used to calculate the test pressure at the wellhead and the pump pressure is shown below. The resulting pressures are given in Table A.4 and A.5. The worst case

burst pressures, and thus the pressure tests, are the same whether gas lift is simulated or not.

$$P_{test@WH} = P_{i,max} - \rho_{test} \cdot (D_{hanger} - D_{WH}) \cdot 0,0981 + BHM \quad (A.8)$$

$$P_{pump} = P_{test@WH} - \rho_{test} \cdot D_{WH} \cdot 0,0981 \quad (A.9)$$

Where:

$P_{test@WH}$  = Test Pressure at Wellhead

$P_{i,max}$  = Maximum Shut-in Wellhead Pressure

$\rho$  = Test Fluid Density

$D_{Hanger}$  = Hanger Depth [TVD]

$D_{Wellhead}$  = Wellhead Depth [TVD]

$P_{Pump}$  = Pump Pressure for Pressure Test

For the 22" casing pressure test (the values are rounded up):

$$P_{test@WH} = 372bar - 1,39sg \cdot (2390m - 2390m) \cdot 0,0981 + 15bar = \mathbf{390 \text{ bar}}$$

$$P_{pump} = \mathbf{390 \text{ bar}} - 1,39sg \cdot 2390m \cdot 0,0981 = 65bar$$

For sections with more than one option for PT-fluid, the worst case (heaviest) is chosen in the Table A.4.

**Table A.4:** Pressure Test Data - No HC (A)

Casing Size[in]	Max SIWHP [bar]	$P_{test}$ @WH [bar]	$P_{test}$ @Hanger [bar]	Test Fluid [sg]	$P_{pump}$ [bar]
22"	372	390	390	1.39	65
18"	431	345	450	1.39	18
16"	477	402	495	1.39	76
13 5/8"	961	1000	1000	1.749	591
9 7/8"	1260	574	1295	1.749	175
TB	623	660	660	1.749	250

**Table A.5:** Pressure Test Data - HC (B)

Casing Size[in]	Max SIWHP [bar]	$P_{test}$ @WH [bar]	$P_{test}$ @Hanger [bar]	Test Fluid [sg]	$P_{pump}$ [bar]
22"	758	775	775	1.39	450
18"	522	451	542	1.39	108
16"	803	727	820	1.39	401
13 5/8"	961	1000	1000	1.749	591
9 7/8"	1260	574	1295	1.749	175
TB	623	660	660	1.749	250

#### A.4.2 Calculating Worst Mud Drop for Lost Returns

The worst mud drop is calculated using the depths and pore pressures for the OH section(s) below the given section. For the 22" casing, mud drop is calculated for all depths below the 22" shoe, down to TD of the 17 1/2" section. Then, the worst mud drop is found, and the resulting depth is put as an input in the *Lost Returns* load case. The mud density is the density used for the given section. The calculations are compared with Stresscheck.

$$TVD_{MudLevel} = \frac{TVD_{pore} \cdot \rho_{pore}}{\rho_{mud}} \quad (A.10)$$

$$h_{MudDrop} = TVD_{pore} - TVD_{mudlevel} = TVD_{pore} - \frac{TVD_{pore} \cdot \rho_{pore}}{\rho_{mud}} \quad (A.11)$$

Where:

$TVD_{MudLevel}$  = TVD for mud level after drop

$TVD_{pore}$  = TVD for given depth

$\rho_{pore}$  = Pore Pressure Density [sg] at given depth

$\rho_{mud}$  = Mud Density used at given depth

$h_{muddrop}$  = Height of Mud Drop [m]

**Table A.6:** Mud Drop Calculations

Casing Size[in]	Mud Density [sg]	TVD of Worst Mud Drop [m]	Mud Drop [m]
22"	1.39	5350	1628
18"	1.39	5350	1628
16"	1.558	5943	1305
13 5/8"	1.702	6858	645
9 7/8"	1.749	7768	284
5 1/2"	1.749	7800	281

### A.4.3 Other Equations

Equation for the required bottomhole pressure during kick simulations (a constant bottomhole pressure is maintained while the gas influx expands) (Halliburton, b):

$$P_{bh} = g \cdot (\rho_{mud} + EMW_{kickintensity} \cdot TVD_{influxdepth}) \quad (A.12)$$

Where:

$P_{bh}$  = Bottomhole Pressure

$g$  = Gravity Constant

$\rho_{mud}$  = Mud Density

$EMW_{kickintensity}$  = Equivalent Mud Weight Kick Intensity

$TVD_{influxdepth}$  = True Vertical Depth of Influx

# Appendix B

## System Description

### B.1 System Specifications

**Table B.1:** Technical data for the Wirth TPK pumps used on Maersk Developer (Aker-Solutions)

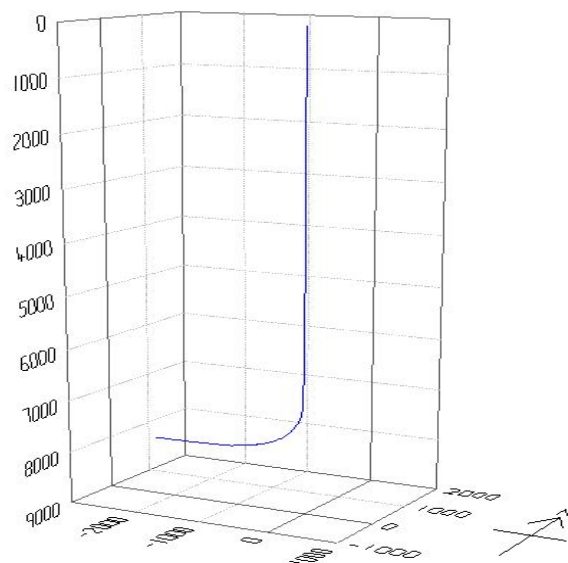
SPECIFICATIONS	
Discharge flow max	3,348 L/min
Operating pressure max	7,500 psi (517 bar)
Input power requirement	2,200 HP
Rated pump speed	110 min <sup>-1</sup>
Max. fluid line bore	7 $\frac{1}{2}$ ”
Stroke	14 ”
Valve size	API 8
Suction connection	10 ” - 150 lb. ANSI B 16.5 WN flange
Discharge connection	4 $\frac{1}{16}$ ”, 10,000 psi API 8 A RTJ

**Table B.2:** *Maersk Developer rig specifications (MaerskDrilling)*

SPECIFICATIONS	
<b>Year of Construction</b>	2009
<b>Class</b>	American Bureau of Shipping
<b>Work Area</b>	Water depths up to 3,000 m (10,000 ft)
<b>Hull dimension</b>	117 m x 78 m x 37 m
<b>Rated water depth (in DP)</b>	500 m to 3,000 m
<b>Rated drilling depth</b>	10,000 m
<b>Variable load</b>	13,500 t
<b>Power supply</b>	Wärtsilä 8x 16 V26 - 4,960 kW
<b>Well control equipment</b>	18 $\frac{3}{8}$ " BOP - 15,000 psi; two annular + six ram preventers
<b>Cranes</b>	
<i>Kingpost crane</i>	60 t SWL; 50 m max reach
<i>Knuckle boom crane</i>	165 t SWL; 50 m max reach
<b>Cement pump</b>	15,000 psi (on free placement)
<b>Main Hoisting capacity</b>	2,000,000 lb
<b>Drawworks</b>	
<i>Main</i>	6,000 hp
<i>Aux</i>	4,600 hp
<b>Top drive</b>	
<i>Main</i>	2,300 hp
<i>Aux</i>	1,150 hp
<b>Mud pumps</b>	4 × 2,200 hp
<b>Bulk mud capacity</b>	4 × 170 m <sup>3</sup>
<b>Bulk cement capacity</b>	4 × 170 m <sup>3</sup>
<b>Liquid mud capacity</b>	18,900 bbl
<b>Accommodation</b>	180 people

**Table B.3:** Wellpath setup for the basecase (Compass)

MD (m)	CL (m)	Inc (°)	Azi (°)	TVD (m)	NS (m)	EW (m)	V.Sec (m)	Dogleg (°/30m)	T.Face (°)	Build (°/30m)	Turn (°/30m)	Section Type
28.01		0.00	0.00	28.01	0.00	0.00	0.00	0.000	0.00	0.000	0.000	Tie Line
6050.01	6022.00	0.00	0.00	6050.01	0.00	0.00	0.00	0.000	0.00	0.000	0.000	Straight MD
6080.01	30.00	1.60	277.00	6080.01	0.05	-0.42	0.42	1.604	277.00	1.604	0.000	DT1 MD
6940.00	859.99	1.60	277.00	6939.66	2.99	-24.31	24.28	0.000	0.00	0.000	0.000	Straight MD
8070.00	1130.00	76.92	268.06	7753.02	-16.61	-688.61	688.75	2.000	-9.00	1.999	-0.237	DT1 MD
8220.00	150.00	76.92	268.06	7786.97	-21.55	-834.64	834.81	0.000	0.00	0.000	0.000	Straight MD
8440.00	220.00	79.04	267.48	7832.78	-29.92	-1049.64	1049.89	0.300	-15.00	0.290	-0.079	DT1 MD
8510.00	70.00	86.67	271.03	7841.48	-30.80	-1119.03	1119.28	3.600	25.00	3.270	1.520	DT1 MD
9660.00	1150.00	88.83	271.81	7886.55	-2.31	-2267.71	2267.62	0.060	20.00	0.056	0.021	DT1 MD

**Figure B.1:** 3D view of the base case well trajectory (Compass)**Table B.4:** Well configuration - Basecase (WellCat)

Name	Type	OD (in)	MD (m)			Hole Size (in)	Annulus Fluid
			Hanger	TOC	Base		
Conductor	Casing	36.000	2388.41	2391.00	2477.41	48.000	Seawater
Surface	Casing	22.000	2387.50	2391.00	3295.50	26.000	1.318 sg WBM
Intermediate	Liner	18.000	3169.93	3230.89	3987.40	22.000	1.162 sg OBM
Intermediate	Liner	16.000	3073.91	4998.73	5943.61	20.000	1.390 sg OBM
Intermediate	Casing	13 5/8	2389.03	6096.01	6858.01	17 1/2	1.558 sg OBM
Production	Liner	10 3/4	6705.00	6705.61	8138.16	12 1/4	1.702 sg OBM
Production	Liner	5 1/2	8061.98	8061.98	9662.18	8 1/2	1.749 sg OBM
Production	Tieback	10 3/4	2390.95	6645.00	6705.00		1.749 sg OBM
Production	Tubing	5.000	2390.95		8061.96		Packer fluid



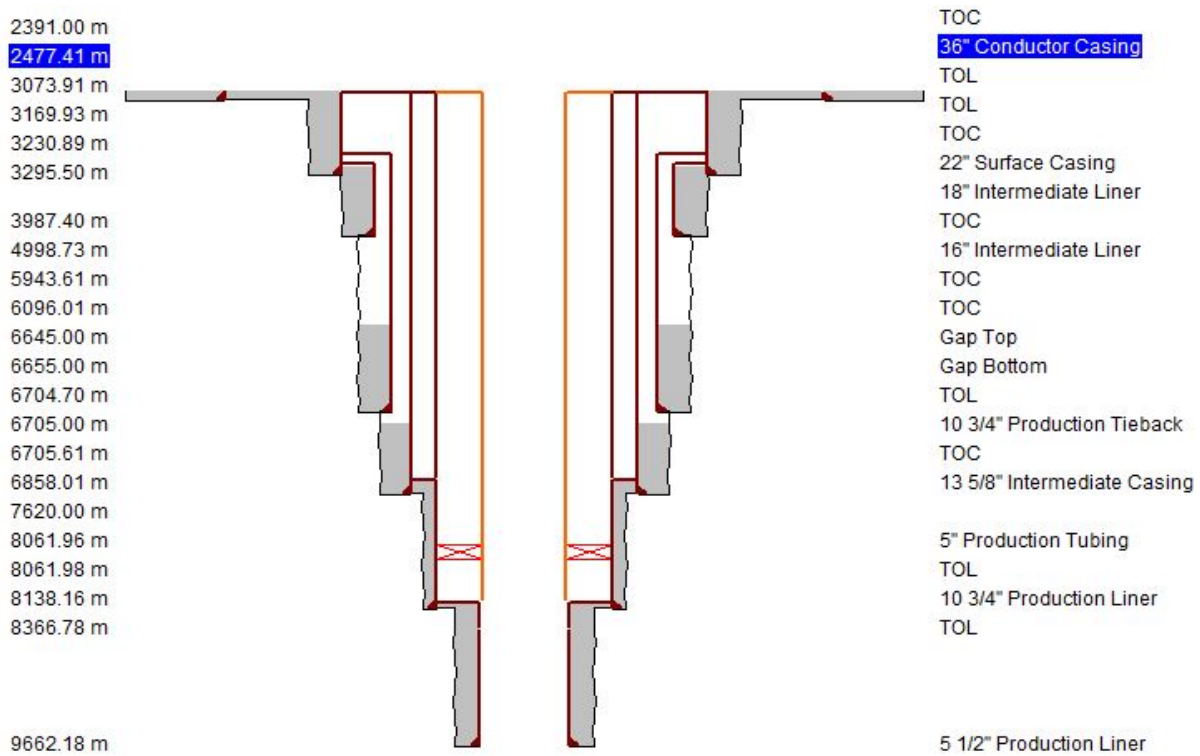
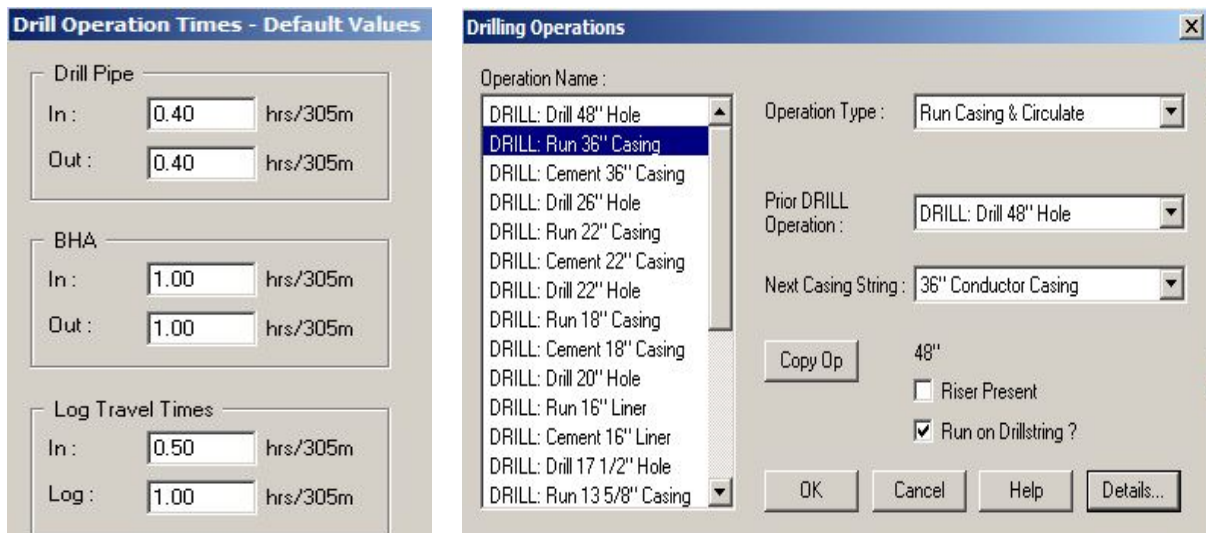


Figure B.2: Well schematic - Basecase (WellCat)

## B.2 WellCat Setups

### B.2.1 General Settings



(a) Operation times for drilling.

(b) Drilling Operations.

Figure B.3: Setup in the Drill Module (WellCat)

## B.3 WellPlan Setups

### B.3.1 General Settings

The friction factors for this study was set to; 0.25 for cased hole, and 0.30 for open hole. These values were estimated together with Alasdair Fleming, based on his work with similar wells. These values will be discussed later in the report.

The same BHA assembly was used in every simulation. The effect on torque and drag simulations caused by changes in BHA assembly were assumed neglectable. The assembly was provided by Statoil. The BHA specifications are shown in Table B.6 in Appendix B.3.

The rig chosen for this thesis was the Maersk Developer. It is operated by Statoil and are specially designed to work in deepwater environments in the Gulf of Mexico. Information on the pump system can be found in Appendix B.

The Maersk Developer is a dynamically positioned semi-submersible drilling rig. It is capable of drilling in water depths up to 3,000 m, and included a number of innovative features which enhance the capacity and flexibility of multiple concurrent activities. (MaerskDrilling) Table B.2 in Appendix B shows some of the specifications for the rig.

**Table B.5:** *Hole section - Drilling 8 1/2" (WellPlan)*

Section Type	Measured Depth (m)	Length (m)	ID	Drift	Effective Hole Diameter (in)	Friction Factor	Linear Capacity (L/m)	Item Description
Riser	2387.47	2387.473	23.000			0.25	268.05	Riser - 24in / 23in
Casing	6703.44	4315.970	11.577	11.421	17.500	0.25	67.91	13 5/8 in, 150.000 ppf, P-110, No C
Casing	8136.60	1433.160	8.013	7.857	12.250	0.25	32.53	9 7/8 in, 87.000 ppf, Q-125, No Con
Open Hole	9662.18	1525.577	8.500		8.500	0.30	36.61	8.500 in

**Table B.6:** *BHA specifications - Drilling 8 1/2" (WellPlan)*

Section Type	Length (m)	Measured Depth	OD (in)	ID (in)	Weight (ppf)	Item Description
Drill Pipe	3493.661	3493.66	6.625	5.375	50.23	Drill Pipe 6.625 in, 40.05 ppf, Z_140, 6-5/8" FH, DSM2
Drill Pipe	6000.000	9493.66	5.875	5.031	28.01	Drill Pipe, 5-7/8 ", 28,01 ppf, S [GOM], VAM Express VX57
Heavy Weight	64.721	9558.38	5.000	3.000	50.14	Heavy Weight Drill Pipe, 5 ", 50.14 ppf, 1340 MOD, VAM EIS 53
Jar	9.562	9567.94	6.500	2.750	91.79	Hydraulic Jar Dailey Hyd., 6 1/2 in
Heavy Weight	37.436	9605.38	5.000	3.000	50.14	Non-Mag Heavy Weight, 5 ", 50.14 ppf, 1340 MOD, VAM EIS 53
Drill Collar	9.144	9614.52	6.750	2.812	100.00	Drill Collar, 6-3/4 ", 100,00 ppf, 4145H MOD, 4 1/2 FH
Stabilizer	1.481	9616.01	6.250	2.812	83.27	Integral Blade Stabilizer 8 3/8" FG, 6 1/4x2 13/16 in
Drill Collar	9.461	9625.47	6.750	2.812	100.00	Drill Collar, 6-3/4 ", 100,00 ppf, 4145H MOD, 4 1/2 SIF
Float Collar	0.613	9626.08	6.750	2.250	100.00	Float Collar, 6-3/4 ", 100,00 ppf, V-150 [SH],
Drill Collar	8.230	9634.31	6.750	2.000	109.84	Non-Mag Drill Collar 6 3/4 in, 2 in, 5 1/2 H-90
Stabilizer	0.588	9634.90	6.250	2.812	83.27	Integral Blade Stabilizer 8 3/8" FG, 6 1/4x2 13/16 in
MWD	8.010	9642.91	6.750	1.906	104.30	Logging While Drilling ALD, 6-3/4" in
MWD	7.181	9650.09	6.750	2.000	104.30	Logging While Drilling EWR-P4, 6-3/4" in
Stabilizer	0.530	9650.62	6.250	2.000	93.72	Near Bit Stabilizer 8 3/8" FG, 6 1/4x2 in
Drill Collar	2.765	9653.38	5.000	2.000	56.12	Drill Collar 5 in, 2 in, 4 FH
Stabilizer	6.151	9659.53	6.750	1.625	141.79	Steerable Stabilizer, 6.750 in, 141.79 ppf, 4145H MOD [SH], 4 1/2" IF
Bit	0.466	9660.00	7.000		143.00	Polycrystalline Diamond Bit, 1x13, 3x14, 0.581 in <sup>2</sup>

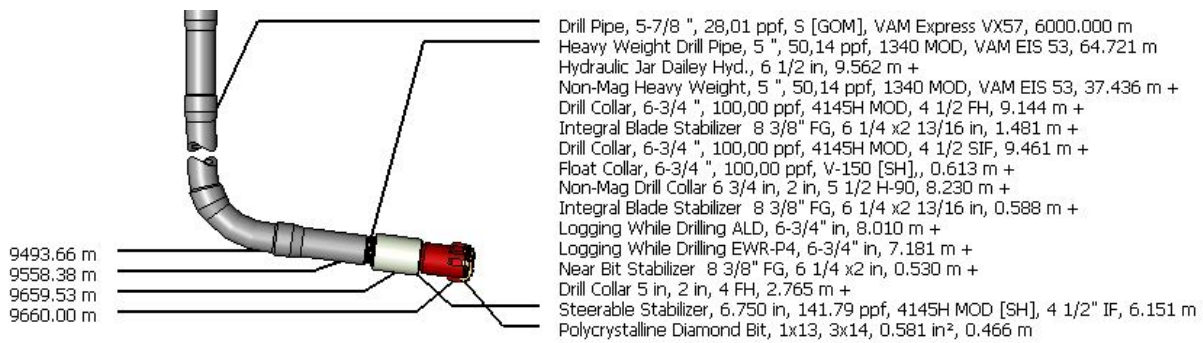


Figure B.4: The BHA assembly (WellPlan)

Table B.7: Running String - Running 5 1/2" Liner (WellPlan)

Section Type	Length (m)	Measured Depth (m)	OD (in)	ID (in)	Weight (ppf)	Item Description
Drill Pipe	6707.179	6707.18	6.625	5.581	41.43	Drill Pipe 6.625 in, 34 ppf, S [GOM], FH, 90%
Drill Pipe	1335.000	8042.18	5.875	5.153	26.48	Drill Pipe 5.875 in, 23.4 ppf, S [GOM], XT-57, 90%
Casing	1620.000	9662.18	5.500	4.250	32.60	5 1/2 in, 32.600 ppf, Q-125, No Connection

**(a) Run parameters (WellPlan)**

**Drilling**

- Rotating On Bottom: WOB/Overpull: 9.00 tonne, Torque at Bit: 7000.0 N-m
- Slide Drilling: tonne, N-m
- Backreaming: tonne, N-m
- Rotating Off Bottom

**Tripping**

- Tripping In: Speed: 15.00 m/min, RPM: 0 rpm
- Tripping Out: Speed: 15.00 m/min, RPM: 0 rpm

**(b) Transport Analysis Data (WellPlan)**

**Input**

- Rate of Penetration: 8.00 m/hr
- Rotary Speed: 120 rpm
- Pump Rate: 1400.0 L/min

**Additional Input**

- Cuttings Diameter: 0.125 in
- Cuttings Density: 2.500 sg
- Bed Porosity: 36.00 %
- MD Calculation Interval: 30.48 m

(a) Run parameters (WellPlan)

(b) Transport analysis data (WellPlan)

Figure B.5: Drilling Setup in WellPlan (WellPlan)

**Transport Analysis Data**

**Input**

- Rate of Penetration: 0.90 m/hr
- Rotary Speed: 0 rpm
- Pump Rate: 1400.0 L/min

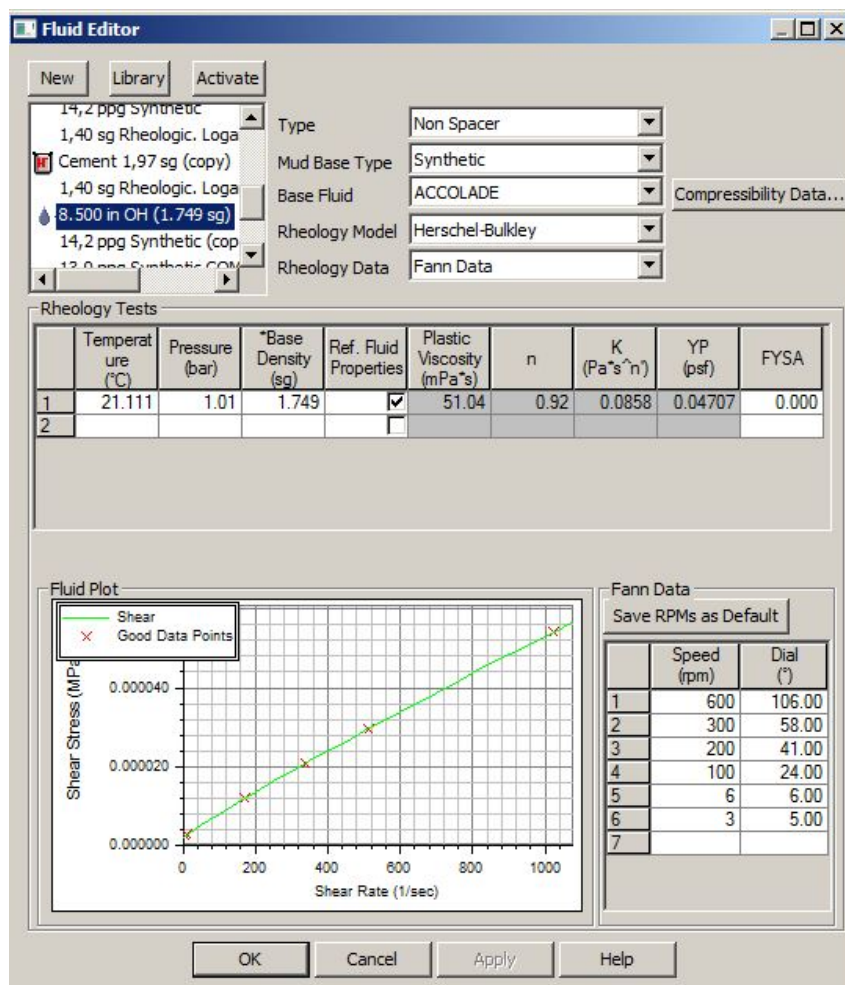
**Additional Input**

- Cuttings Diameter: 0.125 in
- Cuttings Density: 2.500 sg
- Bed Porosity: 36.00 %
- MD Calculation Interval: 30.48 m

Figure B.6: Transport Analysis Data - Running 5 1/2" Liner (WellPlan)

**Table B.8: Job Data - Cementing 5 1/2" Liner (WellPlan)**

	Type	Fluid	New Stage?	Stage No	Placement Method	Rate (L/min)	**Stroke Rate (spm)	Duration (min)	Volume (m <sup>3</sup> )	**Strokes	Top of Fluid (Measured Depth) (m)	Length (m)	Bulk Cement (kg)
1	Drilling Flid (Mud)	8.500 in OH (1.749 sg), 1.749 sg	<input checked="" type="checkbox"/>	1	Volume	1600		0.00			0.00	7721.09	
2	Spacer/Flush	Spacer 16,4 ppg, 1.965 sg	<input checked="" type="checkbox"/>	2	Volume	1600		4.38	7.000		7721.09	441.09	
3	Cement	Cement 1,97 sg, 1.970 sg	<input checked="" type="checkbox"/>	3	Length	1100		29.39	32.334		8162.18	1500.00	34722.6
4	Top Plug*		<input checked="" type="checkbox"/>										
5	Spacer/Flush	Spacer 16,4 ppg, 1.965 sg	<input checked="" type="checkbox"/>	4	Volume	1600		4.38	7.000		8852.43	764.83	
6	Mud	8.500 in OH (1.749 sg), 1.749 sg	<input checked="" type="checkbox"/>	5	Volume	1500		87.49	131.235		0.00	8852.43	
7			<input type="checkbox"/>										



**Figure B.7: Fluid settings - 1.749 sg mud used for drilling 8 1/2" hole (WellPlan)**

# Appendix C

## Simulation Modelling Procedures

This chapter is given for several reasons. The chapter offers a detailed description of the modelling procedure. This will be beneficial if the work will be used in the future. The chapter also offer additional information for readers interested in the developing procedure. The chapter also make the program transparent and easier to understand.

### C.1 WellCat Procedure

WellCat was used to simulate the loads experienced in the well. The load cases were based on Statoil Requirements for well design.

Drilling operations were defined in the Drill module in WellCat. These were used in all simulations. The operations times were set as default. Figure B.3 shows the setup. Three different operations were set up for each section; (1) Drilling the section, (2) Running the casing/liner and (3) Cementing the casing/liner. They were linked together to include the temperature effect from operation to operation. The first drilling operations was linked to “undisturbed”. The riser was set as present from the 18” and smaller.

Production operations were defined in the Production module in WellCat. These were used in all simulations, with the exception of gas lift. Figure D.36 and Figure D.35 shows the resulting pressure and temperature from the simulations.

Figure B.2 and Table B.4 shows well schematic and configuration, respectively. An under-reamer would be used to expand the holes after drilling. This can be seen in Table B.4 in the Hole Size column, as the hole sizes for the next sections are larger or equal to the previous casing.

(Note: As the well was to be drilled in the future, the discussion regarding the execution of the well is written in future terms. The discussion regarding the simulations is written in past tense.)

#### C.1.1 22” surface casing

The 22” casing will be run before the riser is run. The 17 1/2” section will be drilled to a TD of 6,858 m before the 22” casing is sealed off internally. The result from this is that the 22” casing must be able to handle all loads according to the conditions encountered during drilling of the 17 1/2” section. The full internal and external settings are shown in Appendix C.2.1.

##### C.1.1.1 Burst

The *APB* load was added as a custom load and was simulated for both scenarios (A and B) mentioned below. The incremental pressures induced by the increase in temperature were

found in the multistring module in WellCat. They were presented per annuli that had fluids exposed to heating. The internal pressure in the 22" casing will be a combination of the incremental pressure in the C-annulus, the incremental pressure in the D-annulus, the external pressure profile from mix-water density in the 18" section, and the hydrostatic pressure at the wellhead from the drilling fluid used. Figure C.3 shows a schematic of the different annuli. The external pressure will be given by the mixed-water density in the cement and pore pressure in open hole.

**(A) *No hydrocarbons expected before reservoir section:***

Statoil regulations require a 4 m<sup>3</sup> kick when no HC are expected. As mentioned, influx depth must be set to TD of 17 1/2" section (6858 m). Gas gravity is set as default 0.6 (air = 1.0), and the mud density was set to the 1.558 sg OBM used when drilling the 17 1/2" section. Kick intensity was set to 0. Externally, mud weight above TOC was set to 1.318 sg and 1.03 sg below.

The Pressure Test (PT) (Section Design Pressure (SDP)) was based on the "highest pressure expected to be seen at the wellhead", which was the pressure seen from a gas kick. The pump pressure was found by subtracting the hydrostatic column (from RT to the WH) from the the maximum WH pressure. The calculation is shown in Appendix A (Eq. A.8, page A-5). The maximum wellhead pressure from a kick was 375 bar, yielding a SDP of  $375 + 15\text{bar} = 390\text{bar}$ . The mud weight used to drill the 20" section (16" liner) was set to 1.39 sg. Since the 22" casing is exposed when the 16" liner is tested, two pressure tests were simulated; one using 1.318 sg and one using 1.39 sg. The pressure test for the 16" liner was done to 402 bar at the WH. Since the 22" casing is exposed when the 16" liner is tested, this test had to be simulated for the 22" as well.

**(B) *Hydrocarbons can not be excluded before 13 5/8" is set:***

The requirements states that "*if hydrocarbons cannot be excluded in next section, the SDP shall be calculated with gas filled well based on section TD/highest pore pressure and limited to fracture strength at previous shoe. Kill margin shall be included.*" The DTG load setup is shown in Figure C.2 in Appendix C. Influx depth was set to TD of 17 1/2" section, 6,858 m. Gas gravity was set to default 0.6. Fracture margin of error was set to default, 0 sg.

DTG gave the highest WH pressure and formed the basis for calculating the pressure test. The wellhead pressure from a DTG was 758 bar, meaning that the section design pressure had to be  $758 + 15\text{bar} \approx 775\text{bar}$ . Since the 18" section is protected by the 16" liner, a pressure test to the test pressure used in the 16" liner was not necessary. A 1.162 sg OBM was used for the PT.

### C.1.1.2 Collapse

The collapse loads are not dependent on whether HC are expected or not. Two collapse loads were therefore simulated for the 22" casing; cementing and lost returns with mud drop. The *cementing* load case is set up as described in Section 3.2.2.1. Gas lift plans will not impact the loads on the 22" casing, and thus left out of the following discussion.

Lost returns with mud drop was included with the worst possible mud drop. This was found from manual calculations. The calculations and equations used are shown in Appendix A on page A-6 (Eq. A.10). To do this the lowest EMW was found from the next

OH section, then the hydrostatic pressure from the mud column was calculated to balance this pressure. This was the depth that gave the largest mud drop. The fluid was set to the fluid used to drill the next open hole section, which was a 1.39 sg OBM. The worst mud drop was calculated to 1,628 m. The requirements state that “a minimum 250 m mud drop level can be used when drilling in well known fields and formations where experience from neighbour wells document insignificant lost circulation situations.” No loss zones are expected in this section, but the LR case was included for generality.

## C.1.2 18” intermediate liner

### C.1.2.1 Burst

The 18” liner is hung off in the 22” casing. In the next section the 16” liner will be installed higher up in the 22”, and thus covering the 18” liner. The full internal and external settings are shown in Appendix C.2.2.

The burst loads for the 18” casing are the same whether it is planned for gas lift or not. Scenario C and D are therefore left out of the following discussion.

The *APB* load was added as a custom load and was done for both the scenarios mentioned below. The internal pressure in the 18” casing will be a combination of the incremental pressure in the D-annulus and the hydrostatic pressure at the liner hanger from the fluid used (see Figure C.3). The external pressure was given by the mixed-water density in the cement and pore pressure in open hole.

#### ***(A) No hydrocarbons expected before reservoir section:***

The gas kick was set up in the same way as for the 22”, shown in Figure C.1. This included a 4 m<sup>3</sup> kick and a 1.39 sg OBM, as used when drilling the section below the 18” liner. The “above/below prior shoe” external pressure profile was chosen.

Gas kick gave the highest wellhead pressure, with 488 bar, yielding a SDP=  $488 + 15 \approx 505$  bar at the hanger (461 bar at the WH). Since the 18” liner is exposed when drilling the next section, the PT had to be designed for the pressures encountered in this section. Two pressure test were therefore included, one using a 1.162 sg and one using 1.39 sg. Due to the low density of the 1.162 sg fluid, the PT done using this had to be increased. This was to meet the requirement of having an equal or higher differential pressure for the PT than the worst burst case.

A green cement test was included, using the same pump pressure as the pressure test with the actual mud used. A 1.162 sg mud was used with a pump pressure of 144 bar was added.

#### ***(B) Hydrocarbons can not be excluded before 13 5/8” is set:***

The DTG load setup is shown in Figure C.4 in Appendix C.2.2. Influx depth was set to TD of 17 1/2” section, 6,858 m. Gas gravity was set to default 0.6. Fracture margin of error was set to default, 0 sg.

DTG gave the highest WH pressure and formed the basis for calculating the pressure test. The wellhead pressure from a DTG was 522 bar, yielding the section design pressure to be  $522 + 15 \text{ bar} \approx 540$  bar at the hanger (451 bar at the WH). Two pressure test were included, one with a 1.162 sg and one with 1.39 sg.

A green cement test was included, using the same pump pressure as the pressure test with the actual mud used. A 1.162 sg mud was used with a pump pressure of 180 bar was added.

### C.1.2.2 Collapse

The same collapse loads are simulated here as for the 22" casing. The *lost returns with mud drop* load case is set up with loss zone depth at 5,350 m and the fluid used was a 1.39 sg OBM. The worst mud drop was calculated to 1,628 m Table A.6 shows the calculated values for mud drop.

## C.1.3 16" intermediate liner

### C.1.3.1 Burst

The 16" liner will be set to 5,943 m and hung above the 18" liner hanger in the 22" shoe.

The burst loads for the 16" casing were the same whether it was planned for gas lift or not. Scenario C and D are therefore left out of the following discussion. The full internal and external settings are shown in Appendix C.2.3.

The *APB* load was added as a custom load, and was done for both the scenarios mentioned. The internal pressure in the 16" casing will be a combination of the incremental pressure in the C-annulus and the hydrostatic pressure at the liner hanger from the drilling fluid used when drilling the section. The external pressure will include two sections; one above the TOC, which will be a combination of the incremental pressure increase in the D-annulus and the hydrostatic pressure at the liner hanger induced by the drilling fluid used in the previous section. The other below TOC, which will be the pressure corresponding to the hydrostatic column of the mix-water density (see Figure C.3).

#### ***(A) No hydrocarbons expected before reservoir section:***

The burst loads included were gas kick, pressure test and green cement pressure test. The gas kick was set up with a 4 m<sup>3</sup> kick and a 1.558 sg OBM, as used when drilling the 17 1/2" section below the 16" liner. The "above/below prior shoe" external pressure profile was chosen.

Gas kick gave the highest wellhead pressure, with 477 bar, yielding a SDP:  $477 + 15 \approx 495$  bar at the hanger (402 bar at the wellhead). However, this did not cover the requirements for differential pressure. The PT was therefore increased to 515 bar at the hanger (422 bar) at the wellhead), with a pump pressure of 107 bar.

A green cement test was included, using the same pump pressure as the pressure test with the actual mud used. A 1.39 sg mud was used with a pump pressure of 107 bar was added.

#### ***(B) Hydrocarbons can not be excluded before 13 5/8" is set:***

Since hydrocarbons can not be ruled out, displacement to gas had to be evaluated. The DTG load setup is shown in Figure C.5. Influx depth was set to TD of 17 1/2" section, 6,858 m. Gas gravity was set to default 0.6. Fracture margin of error was set to default, 0 sg.



DTG gave the highest WH pressure, with 803 bar, yielding a SDP:  $803 + 15 \approx 820$ bar at the liner hanger (727 bar at the wellhead).

A green cement test was included, using the same pump pressure as the pressure test with the actual mud used. A 1.39 sg mud was used with a pump pressure of 401 bar was added.

### C.1.3.2 Collapse

The same collapse loads were simulated as for the 22" casing. The *lost returns with mud drop* load case was set up with loss zone depth at 5,943 m and the fluid used was a 1.558 sg OBM. The worst mud drop was calculated to 1,305 m. Table A.6 shows the calculated values for mud drop.

## C.1.4 13 5/8" intermediate casing

### C.1.4.1 Burst

The 13 5/8" casing will be set to 6,858 m. It will be hung off in the WH. It was assumed that the 9 7/8" tieback will be run after the completion liner has been run, so that DTG would have a deeper influx source than if the tieback was run prior to drilling the reservoir section. The reasons and results of this will be discussed in Chapter 5. This meant that only one scenario for the burst loads would affect this casing.

The *APB* load was added as a custom load. The internal pressure in the 13 5/8" casing will be induced by the incremental pressure in the B-annulus and the hydrostatic pressure at the wellhead from the fluid used. Since the 9 7/8" tieback will not work as a barrier, a mid-string packer had to be run between the 13 5/8" casing and the tieback. This will create two "zones" where the temperature creates incremental pressure. So, the internal pressure in the 13 5/8" casing were a combination of these two zones (Annulus B1 and B2 in Figure C.3). The external pressure profile will be a combination of two sections; one above the TOC and one below. The above profile will be a combination of the incremental pressure increase in the C-annulus and the hydrostatic pressure at the wellhead induced by the drilling fluid used in the previous section. The below profile corresponds to the mix-water density.

The DTG load setup is shown in Figure C.7. Influx depth was set to TD of the well, 9,662 m. Gas gravity was set to default 0.6. Fracture margin of error was set to 0 sg. DTG gave the highest WH pressure, with 961 bar, yielding a SDP:  $961 + 35 \approx 1000$ bar at the wellhead. Two pressure test were included, one with a 1.558 sg and one with 1.702 sg. The load was linked to the drilling operation of the section below the 13 5/8" section.

A green cement test was included, using the same pump pressure as the pressure test with the actual mud used. A pump pressure of 635 bar was added.

### C.1.4.2 Collapse

#### ***No gas lift plans:***

The same collapse loads are simulated here as for the 22" casing. The *lost returns with mud drop* load case was set up with loss zone depth at 6,858 m and the fluid used was

a 1.702 sg OBM. The worst mud drop was calculated to 645 m. Table A.6 shows the calculated values for mud drop.

***Planned for gas lift:***

In addition to the loads simulated for the 22", *full evacuation* was included. This is only necessary when gas lift included. It was set up using the casing evacuation load in WellCat. Internally, 100 % evacuation was chosen, and the load was linked to the gas lift production operation (which was the "Hottest temp profile from 'Gas lift assisted Prod'-operation"). Externally, the mud weight, 1.558 sg, was chosen above and below the TOC. PP in OH was unchecked. This was a very conservative load case, and will be discussed in detail in the discussion. Figure C.8 shows the setup.

## **C.1.5 9 7/8" production liner**

### **C.1.5.1 Burst**

The 9 7/8" liner will be set to 8,138 m. WellPlan simulations showed that the 6 5/8" DP, used when drilling the 12 1/2" section, had to be extended below the WH. Thus requiring the 9 7/8" to be run as a liner to be able to drill the last OH section (due to lack of clearance). In addition, the completion liner (5 1/2") had to be run with a 6 5/8" running string. This was the reason for running the tieback after the completion liner. As the liner will be exposed when drilling the reservoir section, DTG were simulated. Only one scenario was included for the burst loads.

The *APB* load was added as a custom load. The internal pressure profile in the 9 7/8" liner will be induced by the incremental pressure in the A-annulus and the hydrostatic pressure at the wellhead from the fluid used. The A-annulus can be bled off, so the incremental pressure was assumed to be 0 bar, thus yielding the hydrostatic pressure from the 1.749 sg mud. The external pressure corresponds to the mix-water density. Figure C.3 shows the different annuli.

The DTG load setup is shown in Figure C.9. Influx depth was set to TD of the well, 9,662 m. Gas gravity was set to default 0.6. Fracture margin of error was set to 0 sg. The *tubing leak* load was a default load in WellCat. It was set up as in Figure C.10. The case was linked to the early stage production load (which yields the highest pressure at the WH).

DTG gave the highest WH pressure, with 1,260 bar, yielding a SDP:  $1260 + 35 \approx 1295$  bar at the liner hanger (575 bar at the wellhead). Two pressure test were included, one with a 1.702 sg and one with 1.749 sg. The load was linked to the drilling operation of the section below the 9 7/8" section.

A green cement test was included, using the same pump pressure as the pressure test with the actual mud used. A pump pressure of 175 bar was added.

### **C.1.5.2 Collapse**

The drilling loads for this section were Lost Returns with Mud Drop and Cementing. The production load was Above/below packer. LR with mud drop was included for

generality, even if severe losses are rare while drilling the reservoir section in the GoM. Full Evacuation was included for the gas lift case.

***No gas lift plans:***

The *lost returns with mud drop* load case was set up with loss zone depth at 7,768 m and the fluid used was a 1.749 sg OBM. The worst mud drop was calculated to 284 m. Table A.6 shows the calculated values for mud drop.

The above/below packer was added as a custom load in WellCat. This was the worst collapse load when no plans for gas lift are made. First, a shut-in load was added in the production module. This modelled a major drawdown to simulate the pressure below the packer from a lost communication scenario. The packer was set to 7,620 m. The hydrostatic column from the packer fluid represented the pressure above the packer. The external pressure was given by mud density used in the previous section. The temperatures are given by the “major drawdown shut-in case”.

***Planned for gas lift:***

In addition to the loads simulated for the above mentioned scenario, *full evacuation* was included. It was set up using the casing evacuation load in WellCat. Internally, 100 % evacuation was chosen, and the load was linked to the gas lift production operation (which was the “Hottest temp profile from ‘Gas lift assisted Prod’-operation”). Externally, the mud weight, 1.702 sg, was chosen above and below the TOC. PP in OH was unchecked.

## **C.1.6 9 7/8” production tieback**

### **C.1.6.1 Burst**

Since the tieback will be run after cementing the completion liner, it will not see any drilling. DTG was therefore assumed unnecessary to include. However, a pressure test was included.

Tubing leak gave the highest wellhead pressure. Figure C.12 shows the setup. The case was linked to the early stage production load (which yielded the highest pressure at the WH). The highest pressure seen at the WH was 623 bar, yielding a SDP:  $623+35 \approx 660$  bar at the wellhead. Two pressure test were included, one with a 1.749 sg and one with 1.318 sg packer fluid. The load was linked to the drilling operation of the section below the 9 7/8” section.

### **C.1.6.2 Collapse**

As mentioned, the tieback will only exposed to production loads. This included APB and Full Evacuation.

***No gas lift plans:***

The *APB* load was added as a custom load. The internal pressure profile in the 9 7/8” tieback will be the sum of the incremental pressure in the A-annulus and the hydrostatic pressure at the wellhead from the fluid used. The A-annulus can be bled off, so the incremental pressure will be assumed to be 0 bar, thus yielding the hydrostatic pressure from the 1.749 sg mud. The external pressure corresponds the internal APB pressure for the 13 5/8” casing. This included the two zones created by the mid-string packer. The APB

load case represent the worst collapse load when no gas lift was planned. Figure D.15a shows the differential pressure for the APB load case.

***Planned for gas lift:***

The Full Evacuation was set up using the casing evacuation load in WellCat. Internally, 100 % evacuation was chosen, and the load was linked to the gas lift production operation (which was the “Hottest temp profile from ‘Gas lift assisted Prod’-operation”). Externally, the mud weight, 1.749 sg, was chosen above and below the TOC.

## **C.1.7 5 1/2” production liner**

### **C.1.7.1 Burst**

DTG and Tubing leak were simulated for burst. The DTG load setup is shown in Figure C.14. Influx depth was set to TD of the well, 9,662 m. Gas gravity was set to default 0.6. Fracture margin of error was set to 0 sg. The *tubing leak* load is a default load in WellCat. It was set up as in Figure C.15. The case was linked to the early stage production load (which yields the highest pressure at the WH).

DTG gave the highest WH pressure, with 1,332 bar, yielding a SDP:  $1332 + 35 \approx 1370$  bar at the liner hanger (450 bar at the wellhead). Since the tieback had to be tested to 600 bar (at the wellhead), the 5 1/2” liner had to be tested to this as well. Two pressure tests were simulated, one to 450 bar and one to 600 bar, both with a 1.749 sg. The load was linked to the drilling operation of the section.

A green cement test was included, using the same pump pressure as the pressure test with the actual mud used. A pump pressure of 271 bar was added.

### **C.1.7.2 Collapse**

***No gas lift plans:***

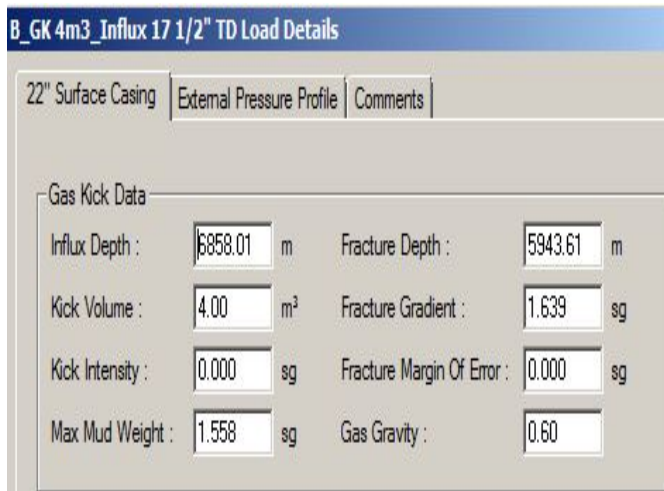
The *lost returns with mud drop* load case was set up with loss zone depth at 7,800 m and the fluid used was a 1.749 sg OBM. The worst mud drop was calculated to 281 m. Table A.6 shows the calculated values for mud drop.

***Planned for gas lift:***

The Full Evacuation was set up using the casing evacuation load in WellCat. Internally, 100 % evacuation was chosen, and the load was linked to the gas lift production operation (which was the “Hottest temp profile from ‘Gas lift assisted Prod’-operation”). Externally, the mud weight, 1.749 sg, was chosen above and below the TOC.

## C.2 Load Case Setups

### C.2.1 22" casing



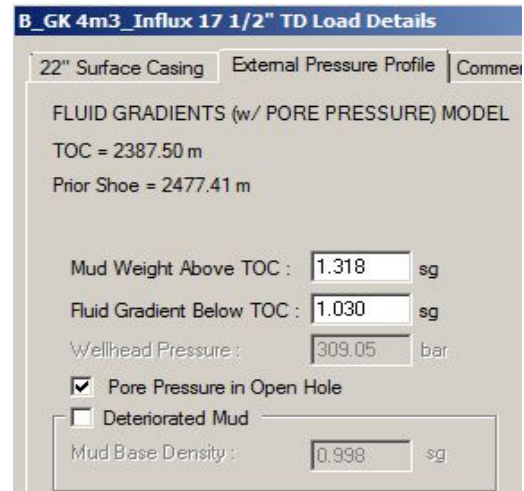
**B\_GK 4m3\_Influx 17 1/2" TD Load Details**

22" Surface Casing | External Pressure Profile | Comments

Gas Kick Data

Influx Depth :	6858.01 m	Fracture Depth :	5943.61 m
Kick Volume :	4.00 m <sup>3</sup>	Fracture Gradient :	1.639 sg
Kick Intensity :	0.000 sg	Fracture Margin Of Error :	0.000 sg
Max Mud Weight :	1.558 sg	Gas Gravity :	0.60

(a) Internal pressure setup.



**B\_GK 4m3\_Influx 17 1/2" TD Load Details**

22" Surface Casing | External Pressure Profile | Comments

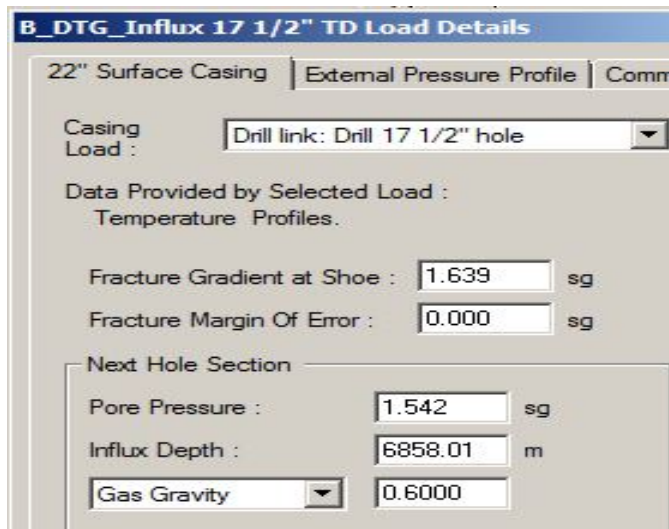
FLUID GRADIENTS (w/ PORE PRESSURE) MODEL

TOC = 2387.50 m  
Prior Shoe = 2477.41 m

Mud Weight Above TOC :	1.318 sg
Fluid Gradient Below TOC :	1.030 sg
Wellhead Pressure :	309.05 bar
<input checked="" type="checkbox"/> Pore Pressure in Open Hole	
<input type="checkbox"/> Deteriorated Mud	
Mud Base Density :	0.998 sg

(b) External pressure setup.

**Figure C.1: Gas Kick setup - 22in. (WellCat)**



**B\_DTG\_Influx 17 1/2" TD Load Details**

22" Surface Casing | External Pressure Profile | Comments

Casing Load : Drill link: Drill 17 1/2" hole

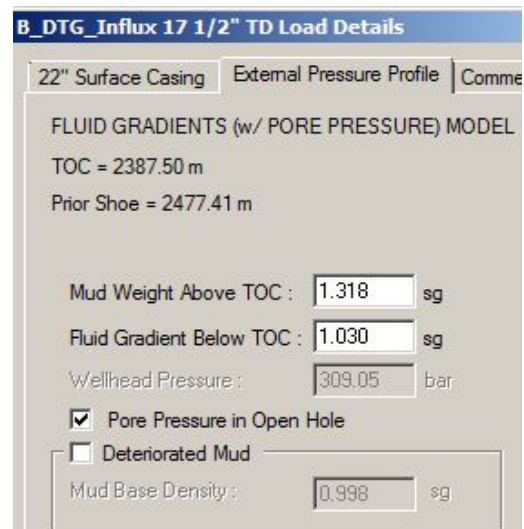
Data Provided by Selected Load :  
Temperature Profiles.

Fracture Gradient at Shoe :	1.639 sg
Fracture Margin Of Error :	0.000 sg

Next Hole Section

Pore Pressure :	1.542 sg
Influx Depth :	6858.01 m
Gas Gravity :	0.6000

(a) Internal pressure setup.



**B\_DTG\_Influx 17 1/2" TD Load Details**

22" Surface Casing | External Pressure Profile | Comments

FLUID GRADIENTS (w/ PORE PRESSURE) MODEL

TOC = 2387.50 m  
Prior Shoe = 2477.41 m

Mud Weight Above TOC :	1.318 sg
Fluid Gradient Below TOC :	1.030 sg
Wellhead Pressure :	309.05 bar
<input checked="" type="checkbox"/> Pore Pressure in Open Hole	
<input type="checkbox"/> Deteriorated Mud	
Mud Base Density :	0.998 sg

(b) External pressure setup.

**Figure C.2: Displacement to Gas setup - 22in. (WellCat)**

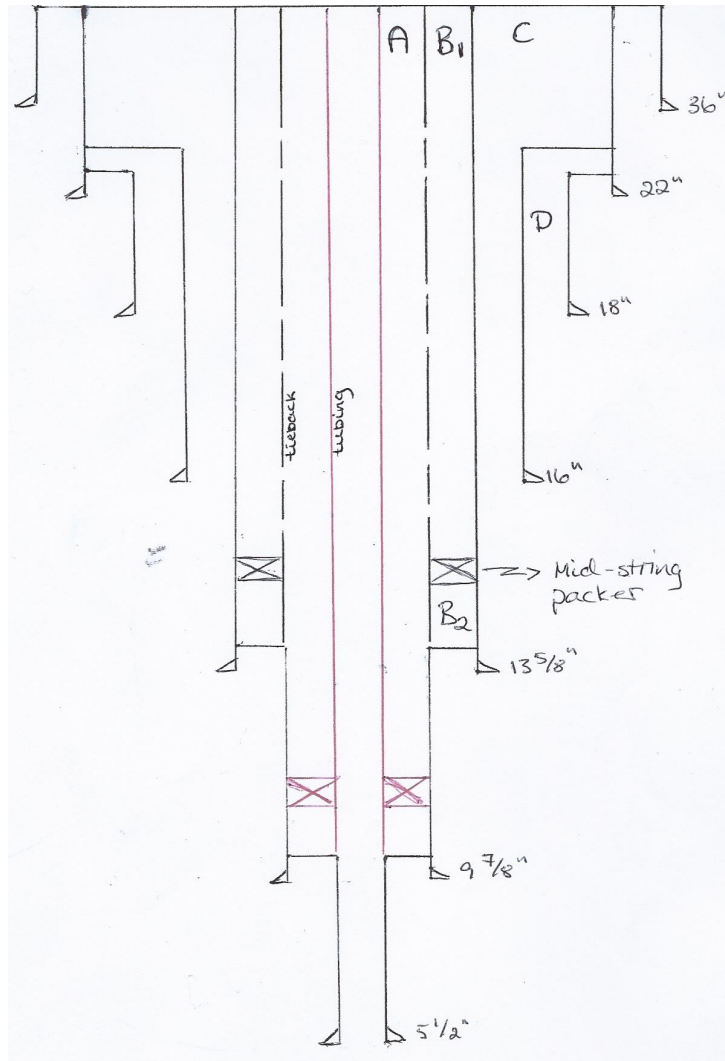
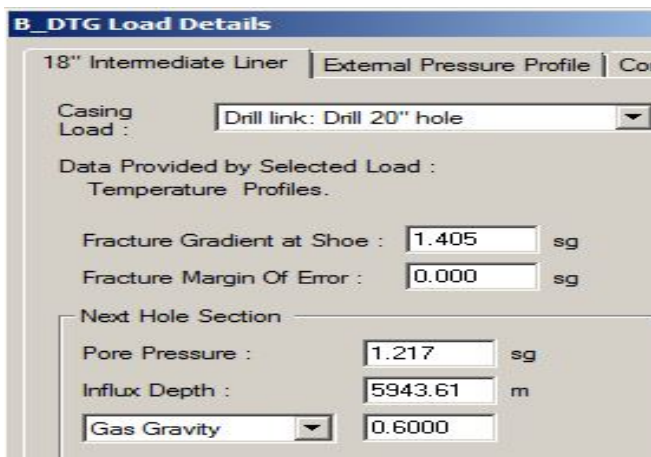
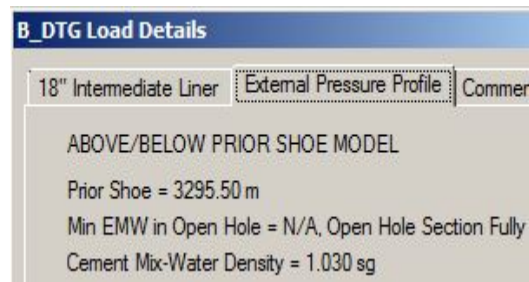


Figure C.3: Well Schematic - Annulus Description

C.2.2 18" liner



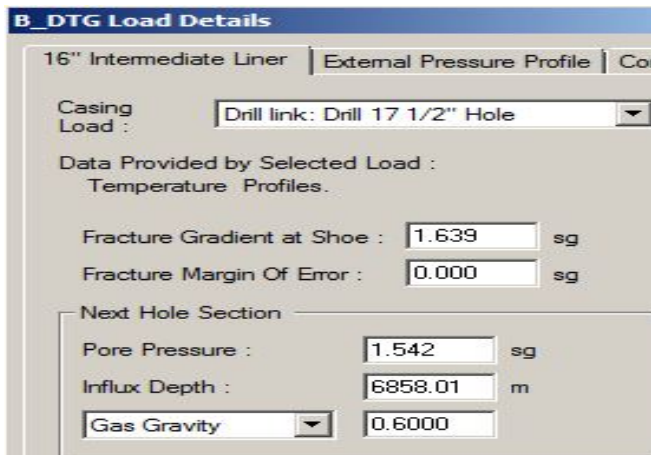
(a) Internal pressure setup.



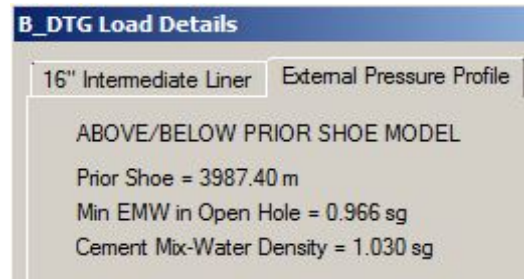
(b) External pressure setup.

Figure C.4: Displacement to Gas setup - 18in. (WellCat)

### C.2.3 16” liner

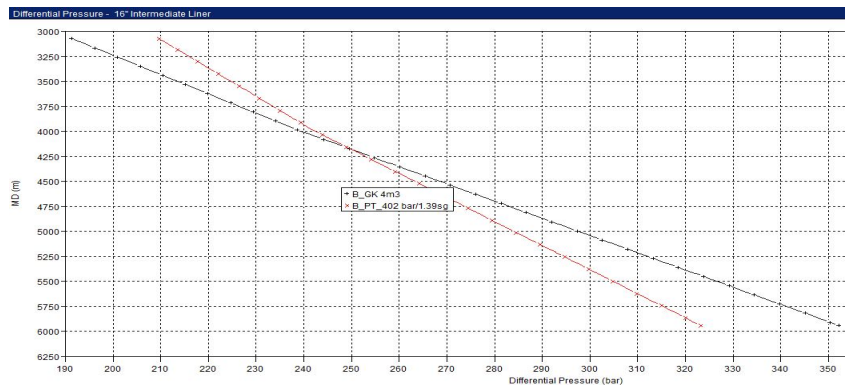


(a) Internal pressure setup.



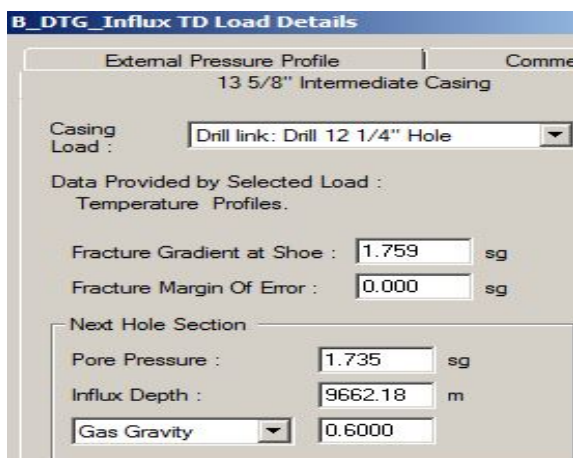
(b) External pressure setup.

**Figure C.5:** Displacement to Gas setup - 16in. (WellCat)

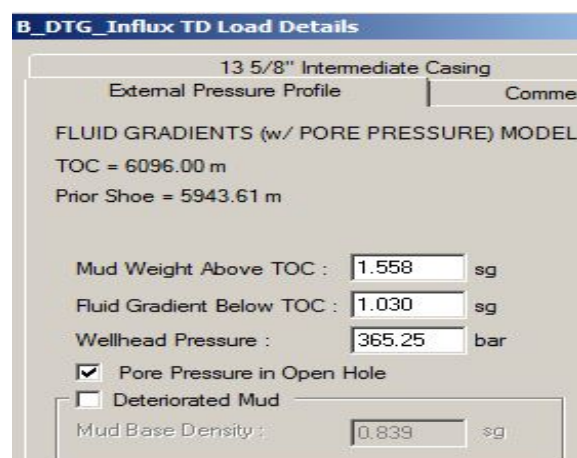


**Figure C.6:** Differential pressure for GK and Pressure Test - Not meeting the Pdiff requirements.

### C.2.4 13 5/8” casing

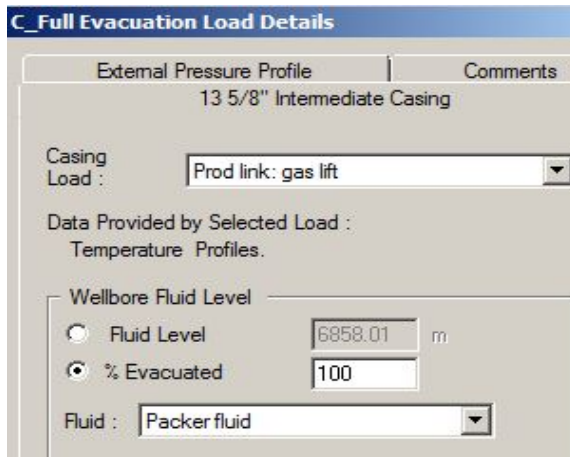


(a) Internal pressure setup.

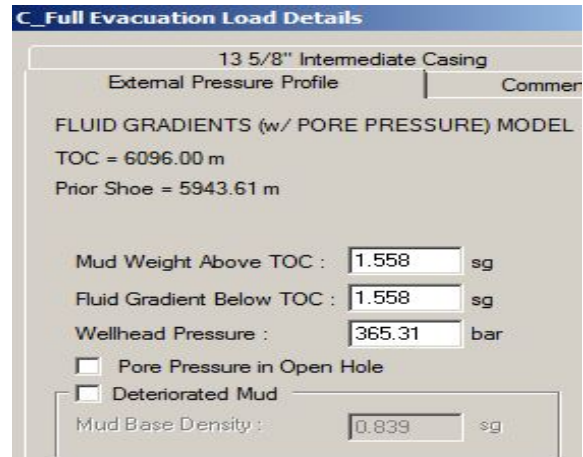


(b) External pressure setup.

**Figure C.7:** Displacement to Gas setup - 13 5/8in. (WellCat)



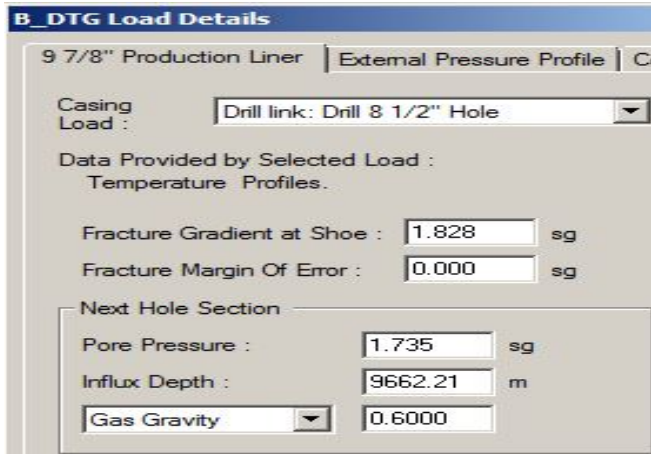
(a) Internal pressure setup.



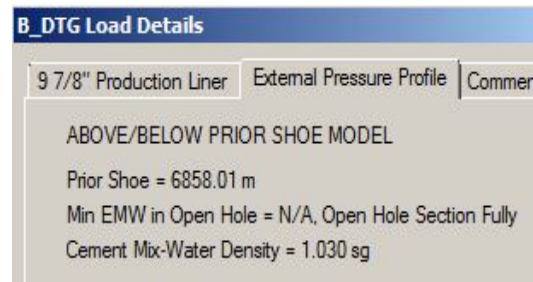
(b) External pressure setup.

**Figure C.8:** Full Evacuation setup - 13 5/8in. (WellCat)

### C.2.5 9 7/8" liner

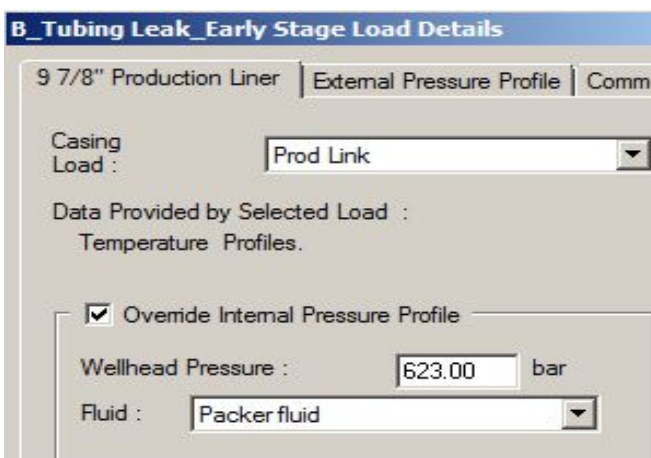


(a) Internal pressure setup.

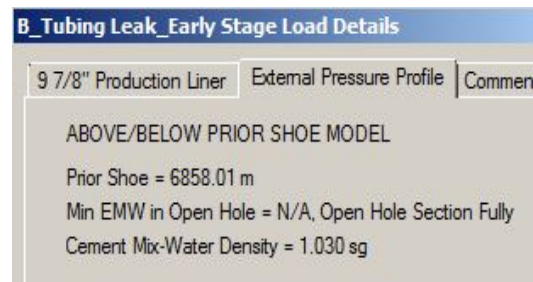


(b) External pressure setup.

**Figure C.9:** Displacement to Gas setup - 9 7/8in. (WellCat)



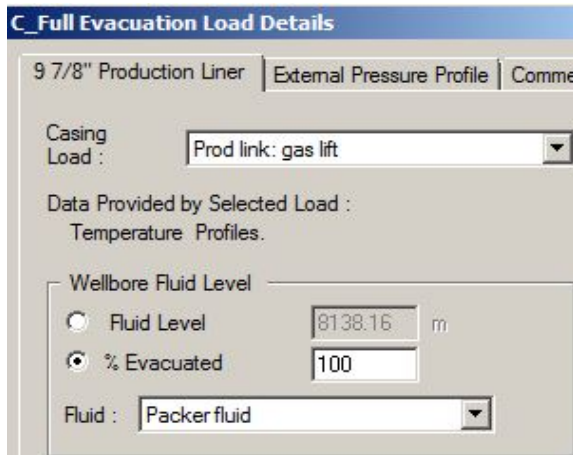
(a) Internal pressure setup.



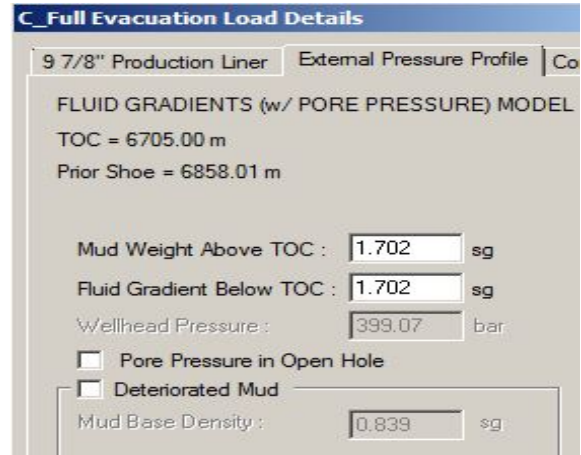
(b) External pressure setup.

**Figure C.10:** Tubing Leak setup - 9 7/8in. (WellCat)





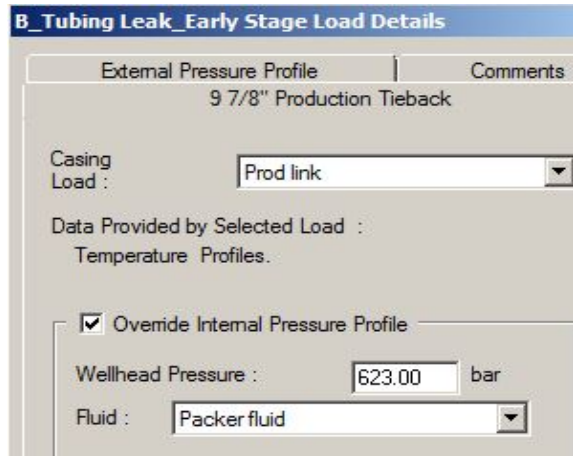
(a) Internal pressure setup.



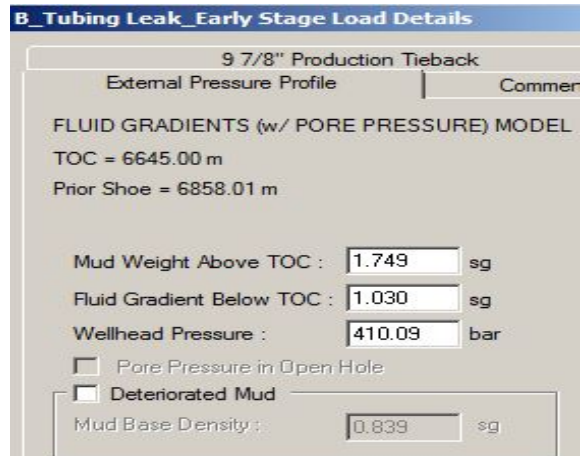
(b) External pressure setup.

**Figure C.11:** Full Evacuation setup - 9 7/8in. (WellCat)

### C.2.6 9 7/8” tieback

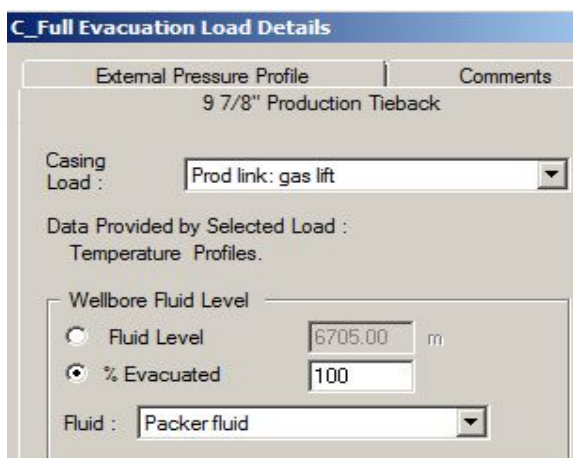


(a) Internal pressure setup.

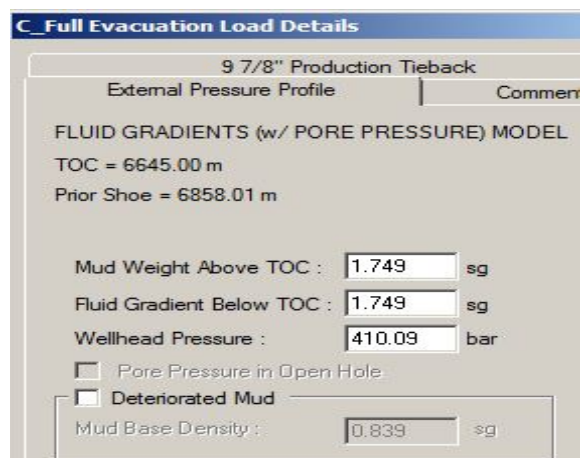


(b) External pressure setup.

**Figure C.12:** Tubing Leak setup - 9 7/8in tieback. (WellCat)



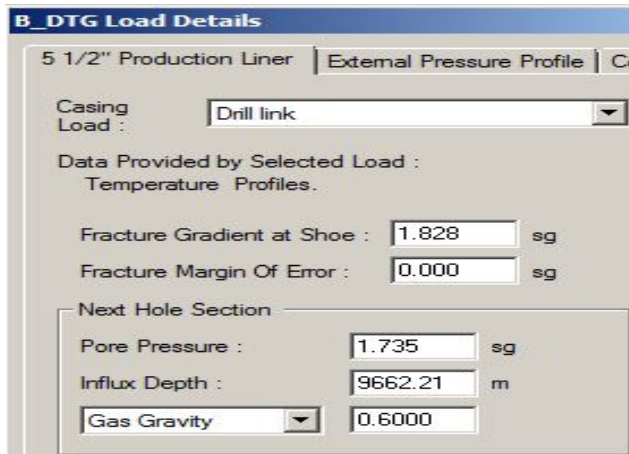
(a) Internal pressure setup.



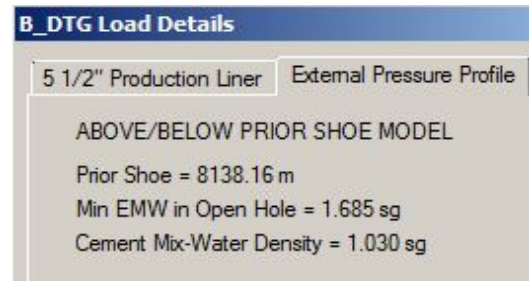
(b) External pressure setup.

**Figure C.13:** Full Evacuation setup - 9 7/8in tieback. (WellCat)

### C.2.7 5 1/2" liner

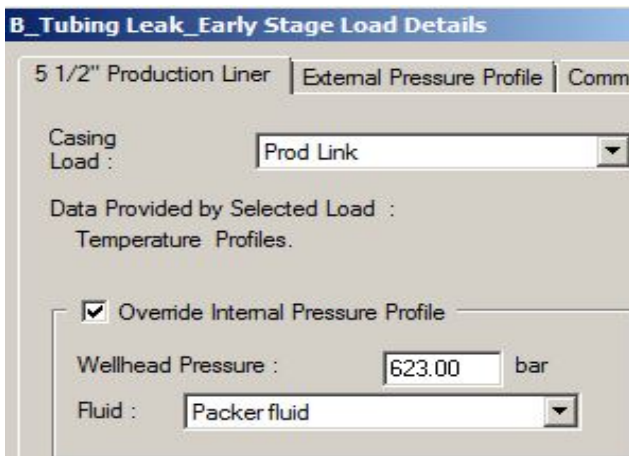


(a) Internal pressure setup.

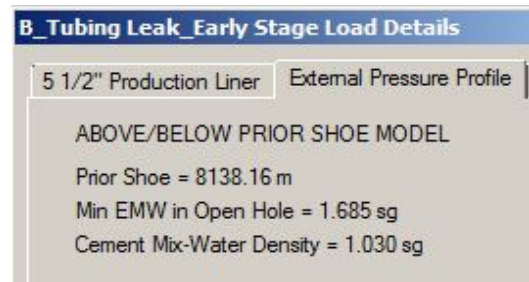


(b) External pressure setup.

**Figure C.14:** DTG setup - 5 1/2in. (WellCat)

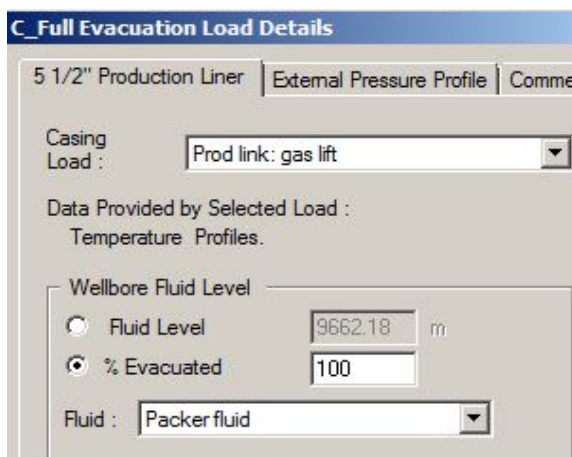


(a) Internal pressure setup.

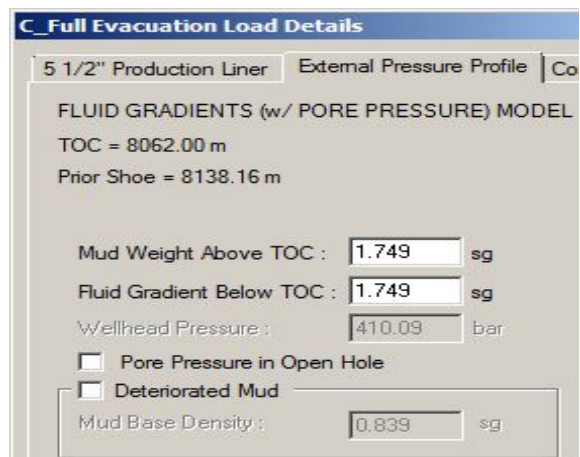


(b) External pressure setup.

**Figure C.15:** Tubing Leak setup - 5 1/2in. (WellCat)



(a) Internal pressure setup.



(b) External pressure setup.

**Figure C.16:** Full Evacuation setup - 5 1/2in. (WellCat)

# Appendix D

## Simulations

### D.1 Well Design - 9 7/8” liner and Tieback

#### D.1.1 22” casing

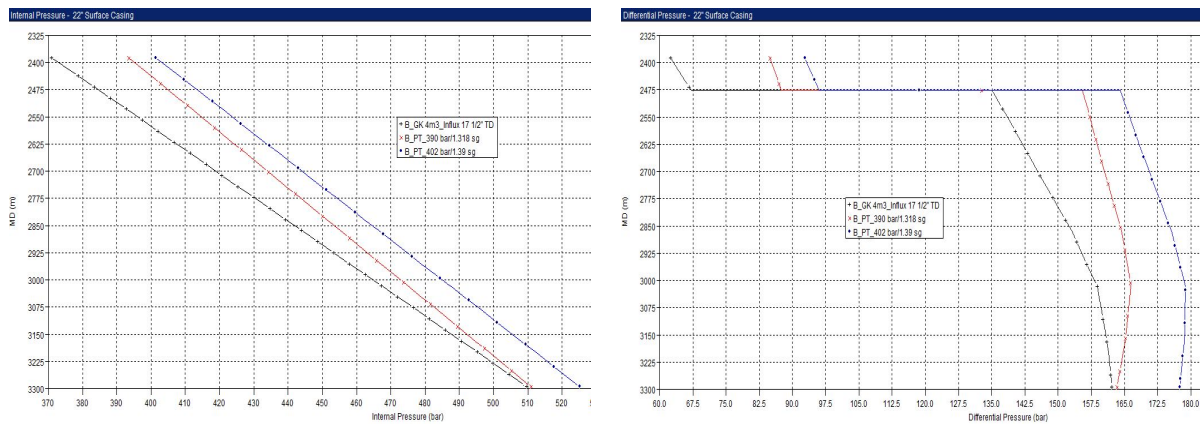
The 22” casing is run before the riser is run. The 17 1/2” section will be drilled to a TD of 6,858 m before the 22” casing is sealed off internally. The result from this is that the 22” casing must be able to handle all loads according to the conditions encountered during drilling of the 17 1/2” section. The full internal and external settings are shown in Appendix C.2.1.

##### D.1.1.1 Burst

The burst loads for the 22” casing are the same whether it is planned for gas lift or not. Scenario C and D are therefore left out of the following discussion.

##### *(A) No hydrocarbons expected before reservoir section:*

Gas kick gave the highest pressure at the wellhead for this section. As seen in Figure D.1a, the maximum wellhead pressure from a kick is 375 bar, yielding the SDP to be  $375 + 15\text{bar} = 390\text{bar}$ . Since the 22” casing is exposed when the 16” liner is tested, two pressure tests were simulated; one using 1.318 sg and one using 1.39 sg. Figure D.1a shows the internal pressure from the pressure tests. The pressure test for the 16” was done to 402 bar at the WH (12 bar higher than for the 22”). Since the 22” casing is exposed when the 16” liner is tested, this test had to be simulated for the 22” as well. Figure D.1b shows that the differential pressure for all the pressure tests are higher than the differential pressure for the gas kick, thus satisfying the requirements for pressure tests.



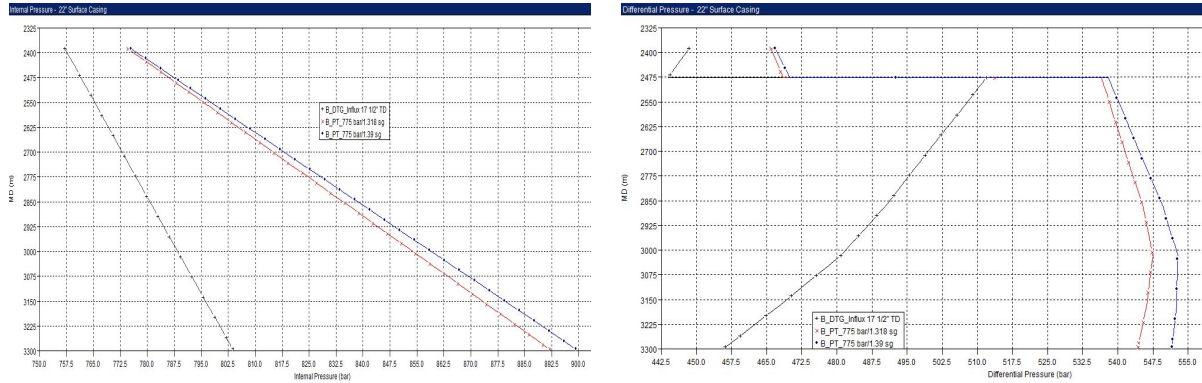
(a) Max SIWHP from Gas Kick (+internal P-profiles for the PTs.)

(b) Differential pressure for Gas Kick and PTs.

**Figure D.1:** Internal and differential pressure for Gas Kick - 22in. (WellCat)

**(B) Hydrocarbons can not be excluded before 13 5/8” is set:**

DTG gave the highest WH pressure and formed the basis for calculating the pressure test. Figure D.2b shows the resulting differential pressures for DTG and the PTs. As seen in Figure D.2a, the wellhead pressure from a DTG is 758 bar, yielding the section design pressure to be  $758 + 15\text{bar} \approx 775\text{bar}$ . Since the 18” section is protected by the 16” liner, a pressure test to the test pressure used in the 16” liner was not necessary.



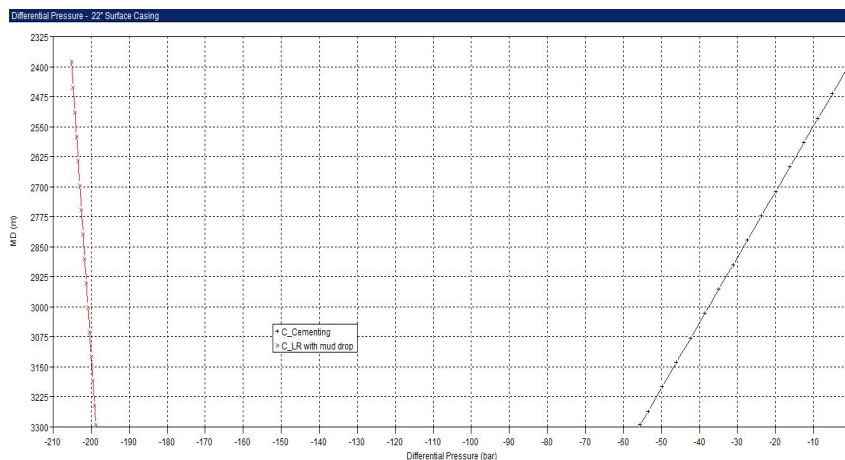
(a) Max shut-in wellhead pressure from DTG (+internal P-profiles for the PTs.) (b) Differential pressure for DTG and Pressure Tests.

**Figure D.2:** Internal and differential pressure for DTG - 22in. (WellCat)

**D.1.1.2 Collapse**

The collapse loads are not dependent on whether HC are expected or not. Two collapse loads were therefore simulated for the 22” casing; cementing and lost returns with mud drop.

Lost returns with mud drop was included with the worst possible mud drop. This was found from manual calculations. The calculations and equations used are shown in Appendix A on page A-6 (Eq. A.10). The worst mud drop was calculated to 1,628 m. No loss zones are expected in this section, but the LR case was included for generality. Figure D.3 shows the differential pressure for cementing and lost returns.



**Figure D.3:** Differential pressure for Lost Returns and Cementing - 22in. (WellCat)

## D.1.2 18" liner

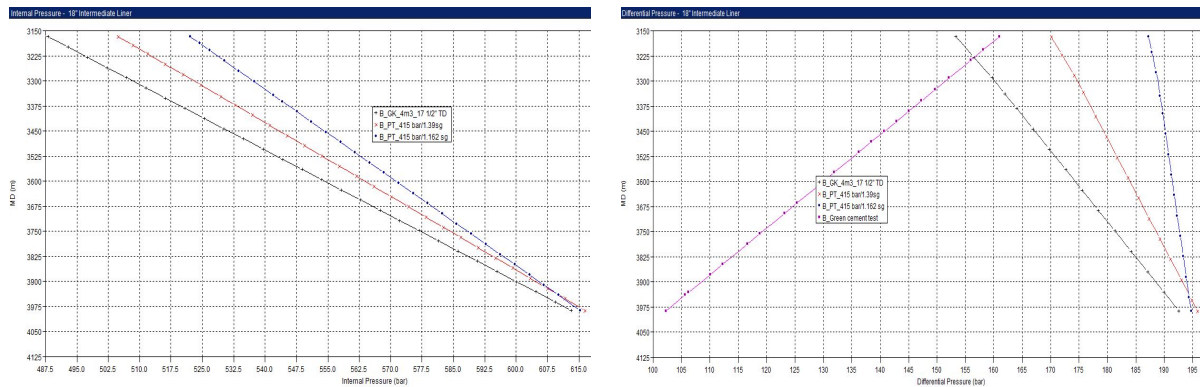
The 18" liner was hung off in the 22" casing. In the next section the 16" liner will be installed higher up in the 22", and thus covering the 18" liner. The full internal and external settings are shown in Appendix C.2.2.

### D.1.2.1 Burst

The burst loads for the 18" casing were the same whether gas lift was included or not. Scenario C and D are therefore left out of the following discussion.

#### (A) No hydrocarbons expected before reservoir section:

Gas kick gave the highest wellhead pressure, with 488 bar, yielding  $SDP = 488 + 15 \approx 505$  bar at the hanger (461 bar at the WH). Since the 18" liner is exposed when drilling the next section, the PT had to be designed for the pressures encountered in this section. Two pressure test were therefore included, one with a 1.162 sg and one with 1.39 sg. Due to the low density of the 1.162 sg fluid, the PT done using this has to be increased compared to the heavier fluid. This is to meet the requirement of having an equal or higher differential pressure for the PT than the worst burst case. The resulting graphs are shown on page A-31 (Figure D.4).



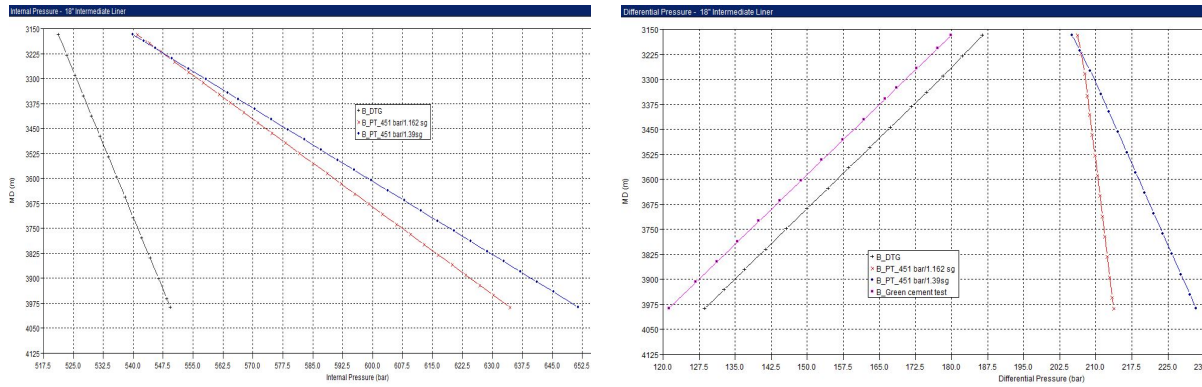
(a) Max shut-in wellhead pressure from Gas Kick (+internal P-profiles for the PTs.)

(b) Differential pressure for Gas Kick and Pressure Tests.

**Figure D.4:** Internal and differential pressure for Gas Kick - 18in. (WellCat)

#### (B) Hydrocarbons can not be excluded before 13 5/8" is set:

DTG gave the highest WH pressure and formed the basis for calculating the pressure test. Figure D.2b shows the resulting differential pressures for DTG and the PTs. As seen in Figure D.2a, the wellhead pressure from a DTG were 522 bar, yielding the section design pressure to be  $522 + 15 \text{ bar} \approx 540$  bar at the hanger (451 bar at the WH). Two pressure test were included, one with a 1.162 sg and one with 1.39 sg. The resulting graphs are shown on in Figure D.5.

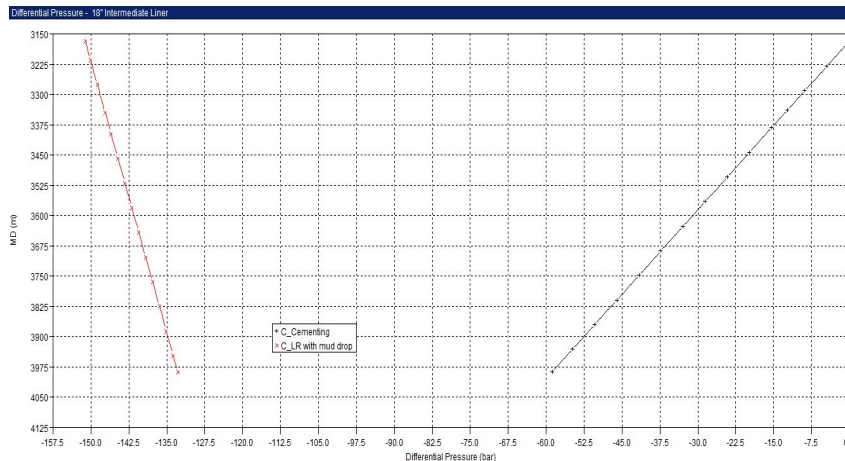


(a) Max shut-in wellhead pressure from DTG (+internal P-profiles for the PTs.) (b) Differential pressure for DTG and Pressure Tests.

**Figure D.5:** Internal and differential pressure for DTG - 18in. (WellCat)

**D.1.2.2 Collapse**

The same collapse loads were simulated here as for the 22” casing. The worst mud drop was calculated to 1,628 m Table A.6 shows the calculated values for mud drop. Figure D.6 shows the differential pressure for cementing and lost returns.



**Figure D.6:** Differential pressure for Lost Returns and Cementing - 18in. (WellCat)

**D.1.3 16” liner**

The 16” liner was set to 5,943 m and hung above the 18” liner hanger in the 22” shoe. The full internal and external settings are shown in Appendix C.2.3.

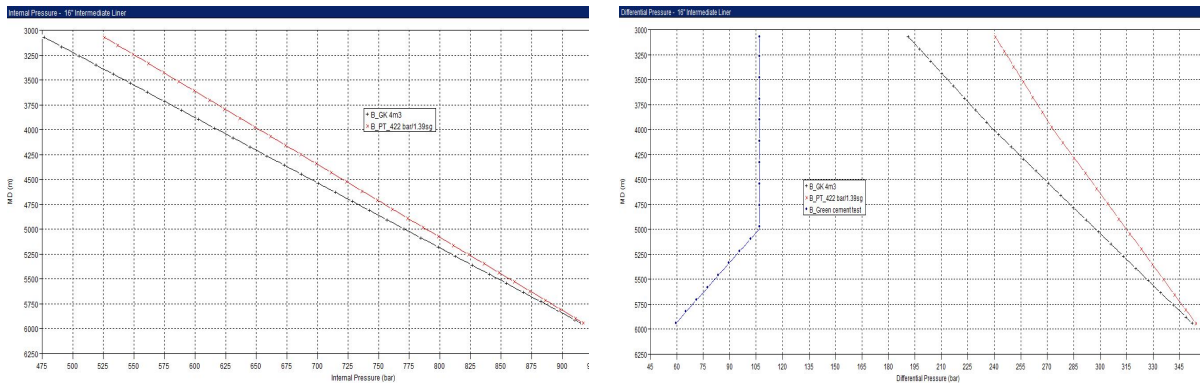
**D.1.3.1 Burst**

The burst loads for the 16” casing are the same whether it is planned for gas lift or not. Scenario C and D are therefore left out of the following discussion.

**(A) No hydrocarbons expected before reservoir section:**

Gas kick gave the highest wellhead pressure, with 477 bar, yielding a SDP:  $477 + 15 \approx 495$  bar at the hanger (402 bar at the wellhead). However, this does not cover the requirements for differential pressure. The PT was therefore increased to 515 bar at the hanger

(422 bar) at the wellhead), with a pump pressure of 107 bar. The resulting graphs are shown in Figure D.8. The graphs for the initial PT (with 76 bar pump pressure) is shown in Figure C.6.

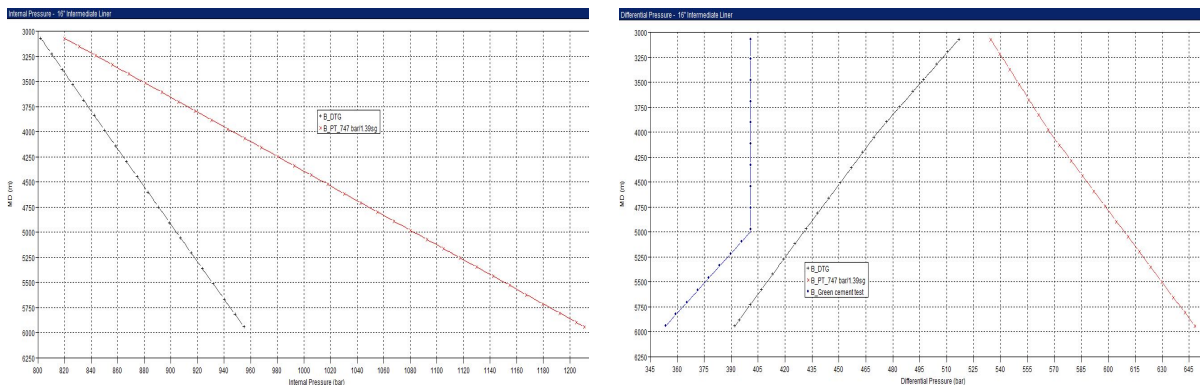


(a) Max shut-in wellhead pressure from Gas Kick (+internal P-profiles for the PTs.) (b) Differential pressure for Gas Kick and Pressure Tests.

**Figure D.7:** Internal and differential pressure for Gas Kick - 16in. (WellCat)

**(B) Hydrocarbons can not be excluded before 13 5/8" is set:**

DTG gave the highest WH pressure, with 803 bar, yielding a SDP:  $803 + 15 \approx 820$ bar at the liner hanger (727 bar at the wellhead). The internal pressure is shown in Figure D.8a. Figure D.8b shows the resulting differential pressure.



(a) Max shut-in wellhead pressure from DTG (+internal P-profiles for the PTs.) (b) Differential pressure for DTG and Pressure Tests.

**Figure D.8:** Internal and differential pressure for DTG - 16in. (WellCat)

**D.1.3.2 Collapse**

The same collapse loads are simulated here as for the 22" casing. The worst mud drop was calculated to 1,305m. Table A.6 shows the calculated values for mud drop. Figure D.9 shows the differential pressure for cementing and lost returns.

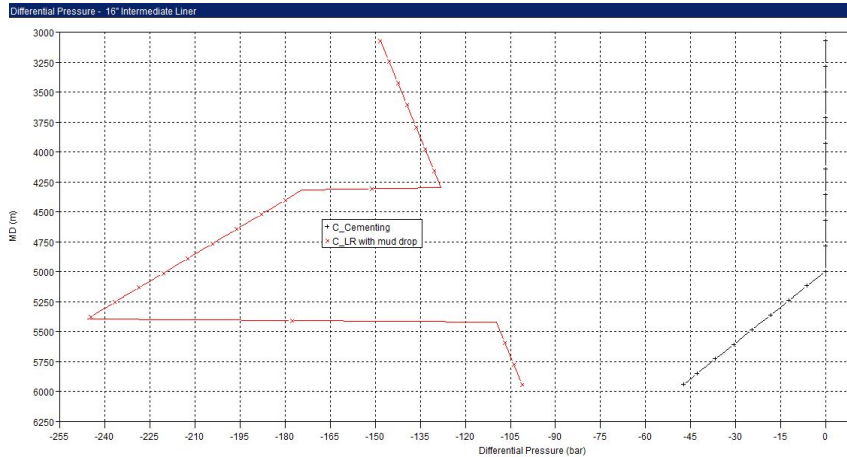


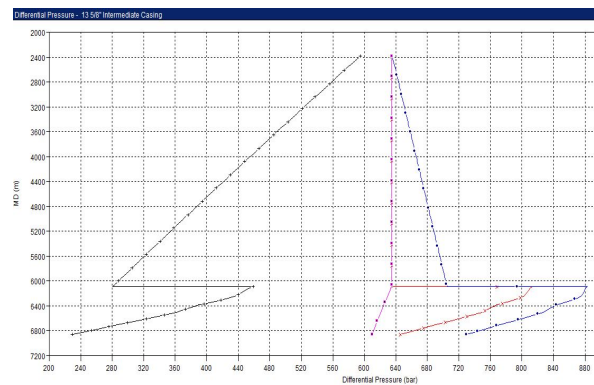
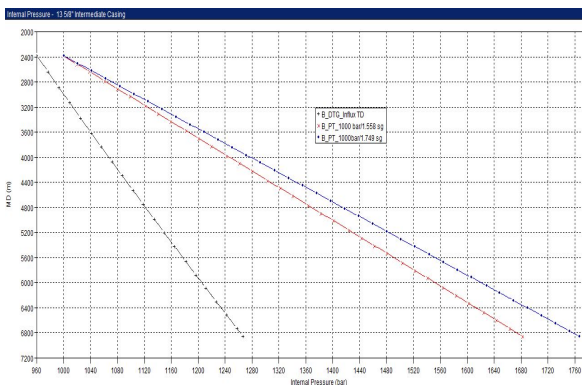
Figure D.9: Differential pressure for Lost Returns and Cementing - 16in. (WellCat)

### D.1.4 13 5/8” casing

The 13 5/8” casing is set to 6,858 m. It will be hung off in the WH. It was assumed that the 9 7/8” tieback is run after the completion liner has been run, so that DTG will have a deeper influx source than if the tieback was run prior to drilling the reservoir section. The reasons and results of this will be discussed in Chapter 5. The result from this is that there was only be one scenario for the burst loads for this casing. The full internal and external settings are shown in Appendix C.2.4.

#### D.1.4.1 Burst

DTG gave the highest WH pressure, with 961 bar, yielding a SDP:  $961 + 35 \approx 1000$ bar at the wellhead. The internal pressure is shown in Figure D.10a. Figure D.10b shows the resulting differential pressure. Two pressure test were included, one with a 1.558 sg and one with 1.702 sg. The load was linked to the drilling operation of the section below the 13 5/8” section.



(a) Max shut-in wellhead pressure from DTG (+internal P-profiles for the PTs.)

(b) Differential pressure for DTG and Pressure Tests.

Figure D.10: Internal and differential pressure for DTG - 13 5/8in. (WellCat)



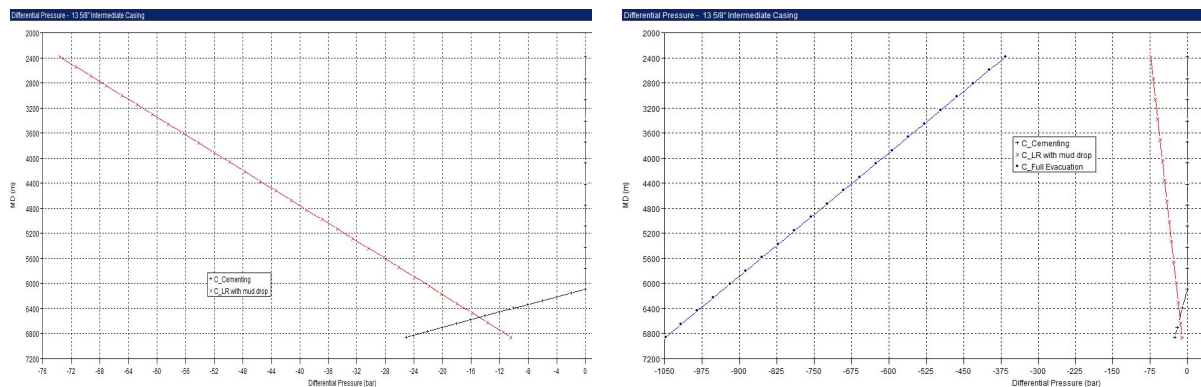
### D.1.4.2 Collapse

#### *No gas lift plans:*

The same collapse loads were simulated here as for the 22" casing. The worst mud drop was calculated to 645 m. Table A.6 shows the calculated values for mud drop. Figure D.11a shows the differential pressure for lost returns and cementing.

#### *Planned for gas lift:*

In addition to the loads simulated for the 22", *full evacuation* was included. This is only necessary when gas lift is included. Figure C.8 shows the setup. Figure D.11 shows the differential pressure for full evacuation versus lost returns.



(a) No Gas Lift - Lost Returns.

(b) Gas Lift - Full Evacuation 13 5/8".

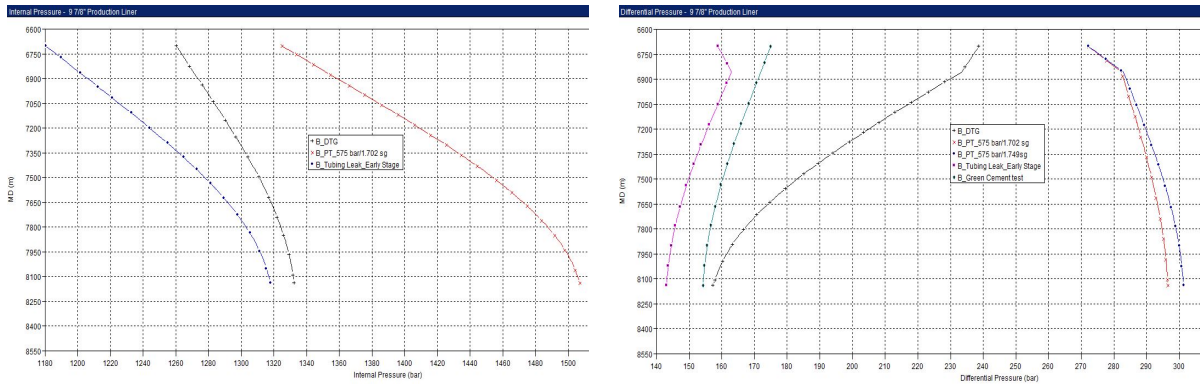
**Figure D.11:** Differential pressure: Lost Returns versus Full Evacuation (No Gas Lift versus Gas Lift) - 13 5/8 in. (WellCat)

## D.1.5 9 7/8" liner

### D.1.5.1 Burst

The 9 7/8" liner will be set to 8,138 m. WellPlan simulations showed that the 6 5/8" DP, used when drilling the 12 1/2" section, had to be extended below the WH. Thus requiring the 9 7/8" to be run as a liner (due to lack of clearance) to be able to drill the last OH section. In addition, the completion liner (5 1/2") had to be run with a 6 5/8" running string. This is the reason for running the tieback after the completion liner. As the liner will be exposed when drilling the reservoir section, DTG were simulated. Only one scenario was included for the burst loads.

DTG gave the highest WH pressure, with 1,260 bar, yielding a SDP:  $1260 + 35 \approx 1295$  bar at the liner hanger (575 bar at the wellhead). The internal pressure is shown in Figure D.12a. Figure D.12b shows the resulting differential pressure. Two pressure test were included, one with a 1.702 sg and one with 1.749 sg.



(a) Max shut-in wellhead pressure from DTG (+internal P-profiles for the PTs.) (b) Differential pressure for DTG and Pressure Tests.

Figure D.12: Internal and differential pressure for DTG - 9 7/8in. (WellCat)

D.1.5.2 Collapse

The drilling loads for this section were Lost Returns with Mud Drop and Cementing. The production load was Above/below packer. LR with mud drop was included for generality, even if severe losses are rare while drilling the reservoir section in the GoM. Full Evacuation was included for the gas lift case.

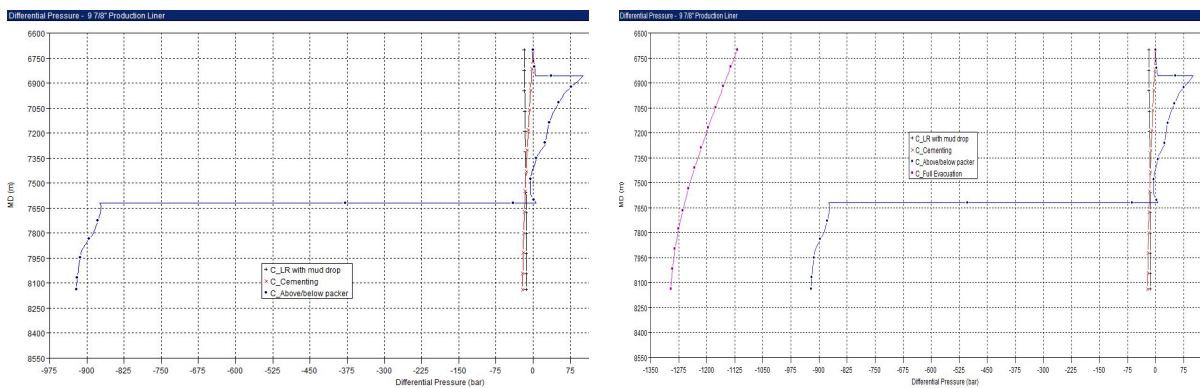
No gas lift plans:

The worst mud drop was calculated to 284 m. Table A.6 shows the calculated values for mud drop. Figure D.13a shows the differential pressure for lost returns, cementing and above/below packer. Above/below packer was the worst collapse load when no plans for gas lift were made.

Planned for gas lift:

In addition to the loads simulated for the above mentioned scenario, full evacuation was included. This is only necessary when gas lift is included. Figure C.11 shows the setup. Figure D.13 shows the differential pressure for full evacuation versus lost returns.

The packer was set to 7,620 m. The hydrostatic column from the packer fluid represents the pressure above the packer. The external pressure was given by cement. The temperatures are given by the “major drawdown shut-in case”.



(a) No Gas Lift - Above/below packer. (b) Gas Lift - Full Evacuation 9 7/8".

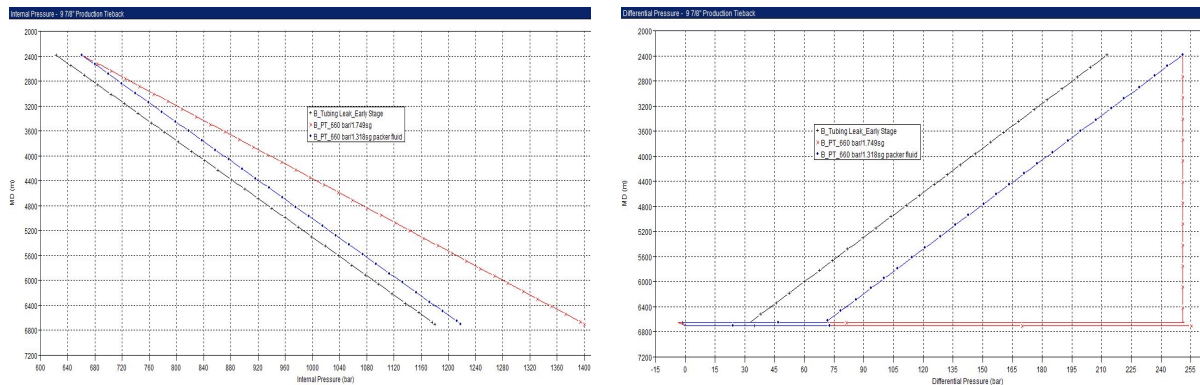
Figure D.13: Differential pressure: Above/below packer versus Full Evacuation (No Gas Lift versus Gas Lift) - 9 7/8in. (WellCat)

## D.1.6 9 7/8" tieback

### D.1.6.1 Burst

Since the tieback is run after cementing the completion liner, it will not see any drilling. DTG is therefore assumed unnecessary to include. However, a pressure test was included. The only burst load simulated was Tubing Leak.

Tubing leak gave the highest wellhead pressure. Figure C.12 shows the setup. Figure... shows the production pressures. The highest pressure seen at the WH was 623 bar, yielding a SDP:  $623 + 35 \approx 660$  bar at the wellhead. The internal pressure is shown in Figure D.14a. Figure D.14b shows the resulting differential pressure. Two pressure test were included, one with a 1.749 sg and one with 1.318 sg packer fluid.



(a) Max shut-in wellhead pressure from Tubing Leak (+internal P-profiles for the PTs.)

(b) Differential pressure for Tubing Leak and Pressure Tests.

**Figure D.14:** Internal and differential pressure for TL - 9 7/8in tieback. (WellCat)

### D.1.6.2 Collapse

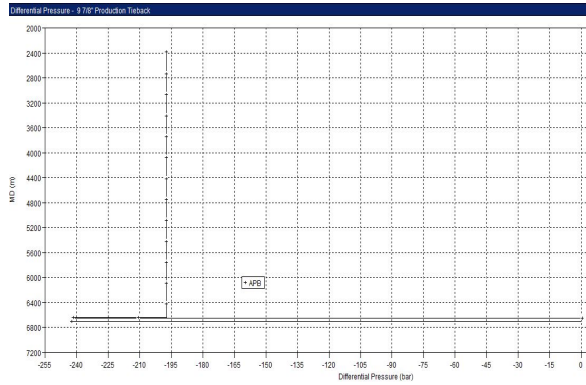
The tieback is only exposed to production loads. This includes APB and Full Evacuation.

#### **No gas lift plans:**

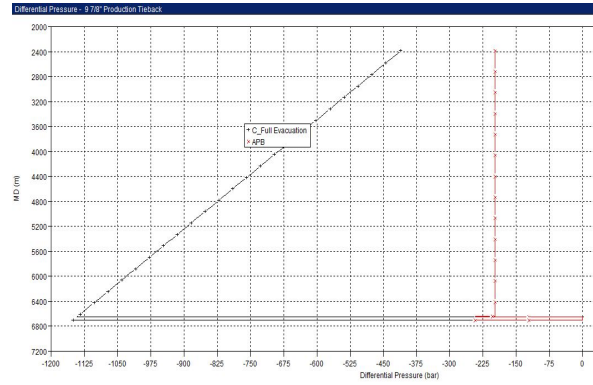
The APB load case represent the worst collapse load when no gas lift is planned. Figure D.15a shows the differential pressure for the APB load case.

#### **Planned for gas lift:**

Figure C.13 shows the setup. Figure D.15 shows the differential pressure for full evacuation versus lost returns.



(a) No Gas Lift - APB.



(b) Gas Lift - Full Evacuation 9 7/8" TB.

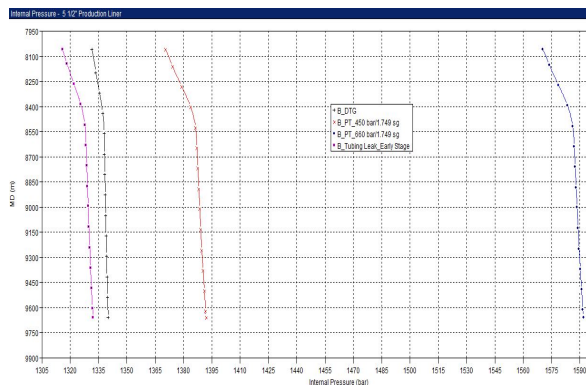
**Figure D.15:** Differential pressure: APB versus Full Evacuation (No Gas Lift versus Gas Lift) - 9 7/8in tieback. (WellCat)

### D.1.7 5 1/2" liner

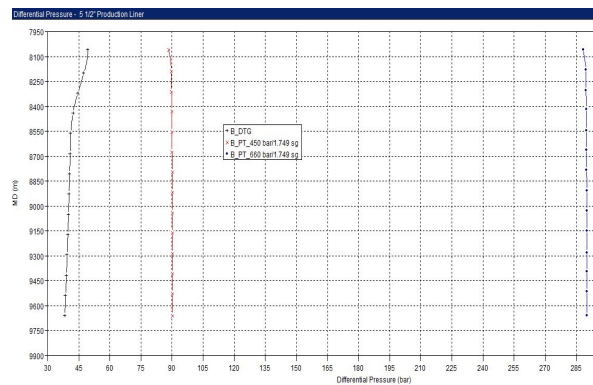
#### D.1.7.1 Burst

DTG and Tubing leak were simulated for burst. The DTG load setup is shown in Figure C.14. The *tubing leak* load was set up as in Figure C.15. Figure... shows the production pressures.

DTG gave the highest WH pressure, with 1,332 bar, yielding a SDP:  $1332 + 35 \approx 1370$  bar at the liner hanger (450 bar at the wellhead). The internal pressure is shown in Figure D.16a. However, since the tieback had to be tested to 600 bar (at the wellhead), the 5 1/2" liner had to be tested to this as well. Figure C.14 shows the resulting differential pressure. Two pressure tests were simulated, one to 450 bar and one to 600 bar, both with a 1.749 sg.



(a) Max shut-in wellhead pressure from DTG (+internal P-profiles for the PTs.)



(b) Differential pressure for DTG and Pressure Tests.

**Figure D.16:** Internal and differential pressure for DTG - 5 1/2in tieback. (WellCat)

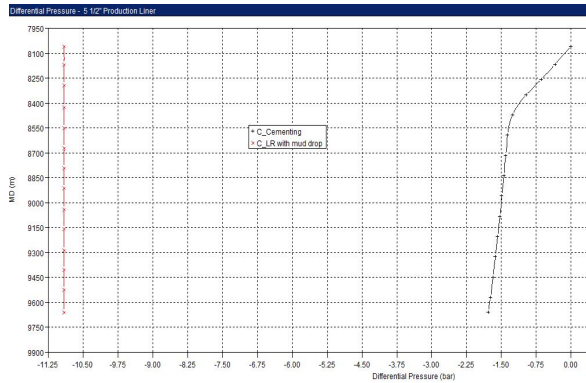
#### D.1.7.2 Collapse

##### No gas lift plans:

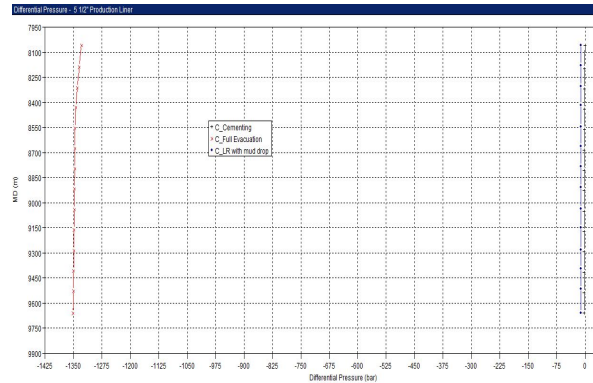
The worst mud drop was calculated to 281 m. Table A.6 shows the calculated values for mud drop. Figure D.17a shows the differential pressure for lost returns and cementing.

**Planned for gas lift:**

Figure C.16 shows the setup. Figure D.17 shows the differential pressure for full evacuation versus lost returns.



(a) No Gas Lift - Lost Returns.



(b) Gas Lift - Full Evacuation 5 1/2\".

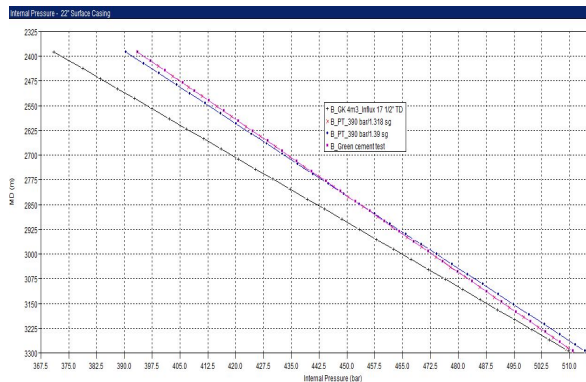
**Figure D.17:** Differential pressure: Lost Returns versus Full Evacuation (No Gas Lift versus Gas Lift) - 5 1/2in. (WellCat)

## D.2 Well Design - Base Case

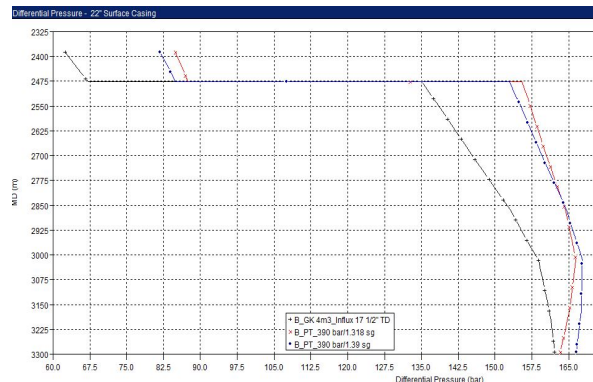
### D.2.1 22” casing

#### D.2.1.1 Burst

(A) No hydrocarbons expected before reservoir section:



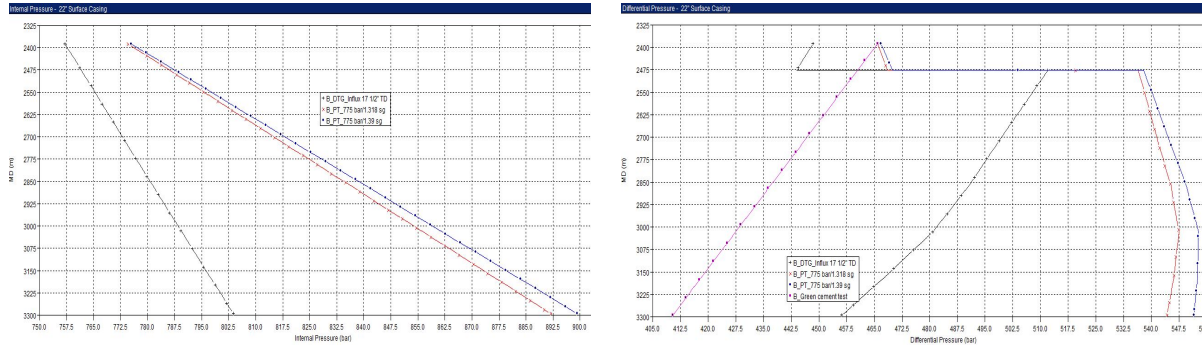
(a) Max shut-in wellhead pressure from Gas Kick (+internal P-profiles for the PTs.)



(b) Differential pressure for Gas Kick and Pressure Tests.

**Figure D.18:** Internal and differential pressure for Gas Kick - 22in. (WellCat)

**(B) Hydrocarbons can not be excluded before 13 5/8" is set:**

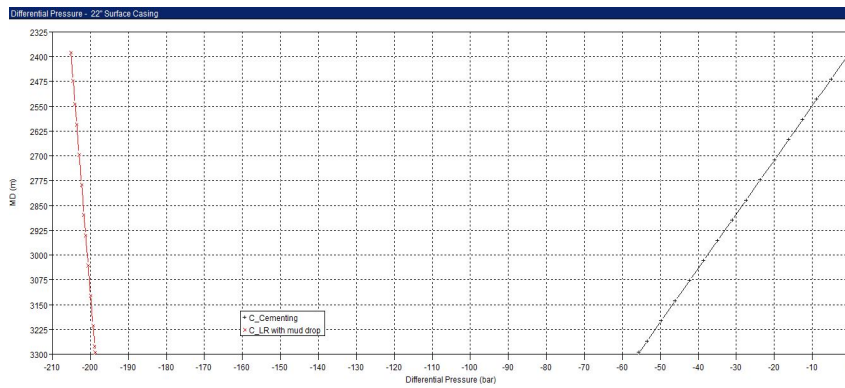


**(a)** Max shut-in wellhead pressure from DTG (+internal P-profiles for the PTs.)

**(b)** Differential pressure for DTG and Pressure Tests.

**Figure D.19:** Internal and differential pressure for DTG - 22in. (WellCat)

**D.2.1.2 Collapse**

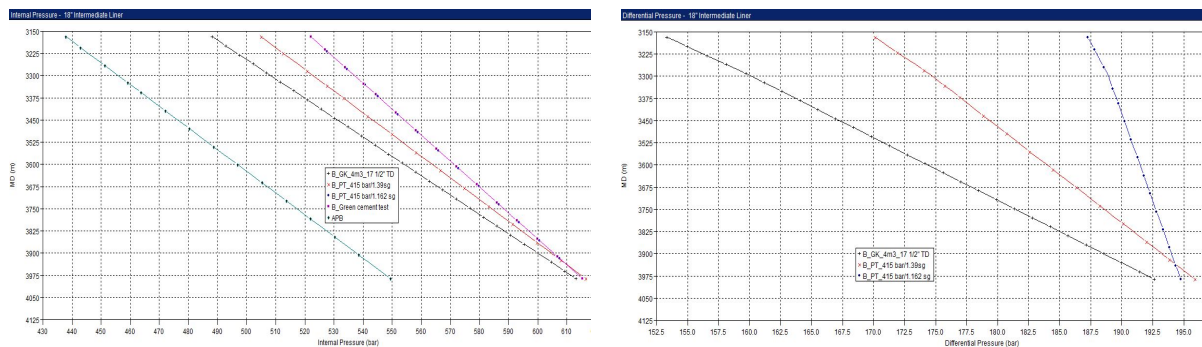


**Figure D.20:** Differential pressure for Lost Returns and Cementing - 22in. (WellCat)

**D.2.2 18" liner**

**D.2.2.1 Burst**

**(A) No hydrocarbons expected before reservoir section:**

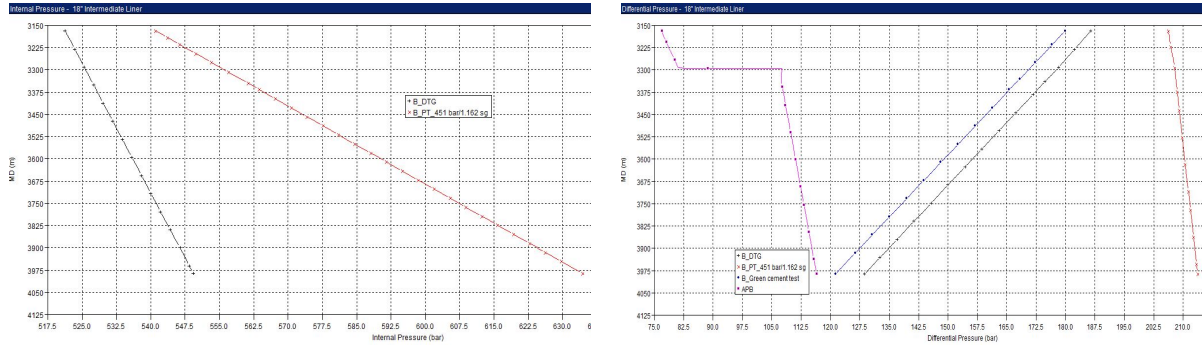


**(a)** Max shut-in wellhead pressure from Gas Kick (+internal P-profiles for the PTs.)

**(b)** Differential pressure for Gas Kick and Pressure Tests.

**Figure D.21:** Internal and differential pressure for Gas Kick - 18in. (WellCat)

**(B) Hydrocarbons can not be excluded before 13 5/8" is set:**

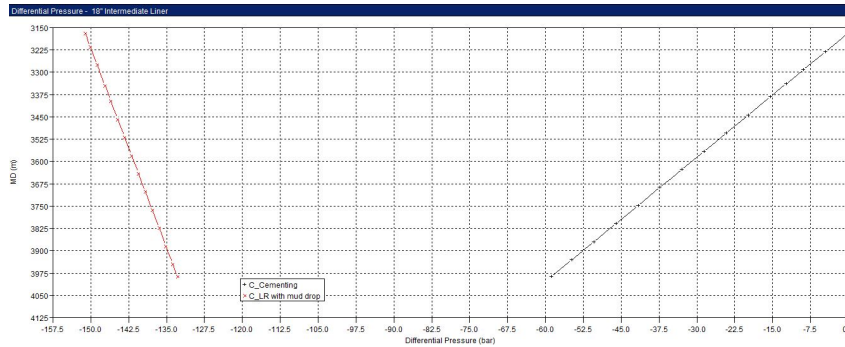


**(a)** Max shut-in wellhead pressure from DTG (+internal P-profiles for the PTs.)

**(b)** Differential pressure for DTG and Pressure Tests.

**Figure D.22:** Internal and differential pressure for DTG - 18in. (WellCat)

**D.2.2.2 Collapse**

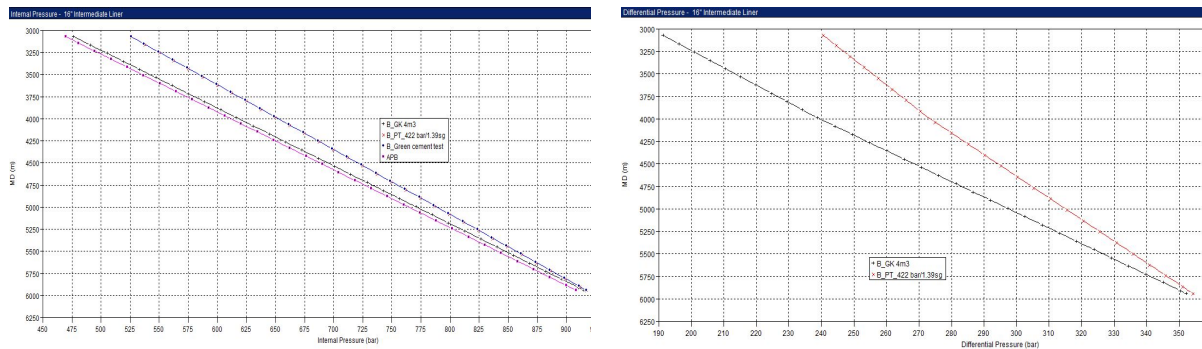


**Figure D.23:** Differential pressure for Lost Returns and Cementing - 18in. (WellCat)

**D.2.3 16" liner**

**D.2.3.1 Burst**

**(A) No hydrocarbons expected before reservoir section:**

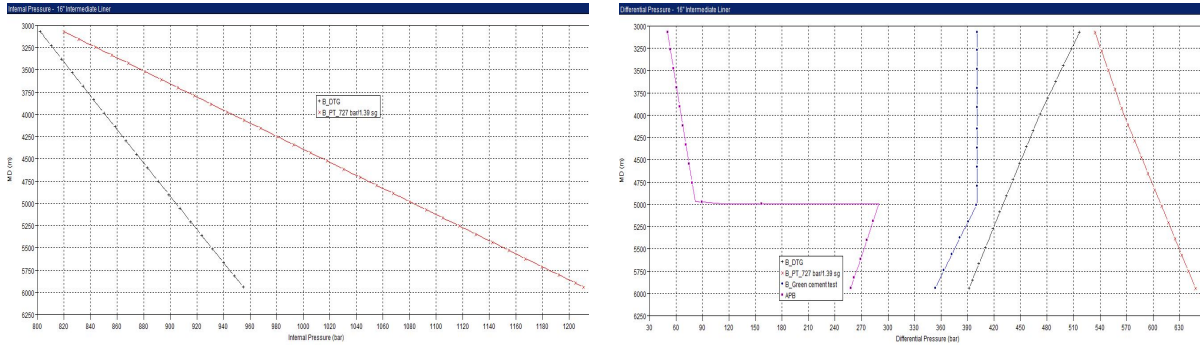


**(a)** Max shut-in wellhead pressure from Gas Kick (+internal P-profiles for the PTs.)

**(b)** Differential pressure for Gas Kick and Pressure Tests.

**Figure D.24:** Internal and differential pressure for Gas Kick - 16in. (WellCat)

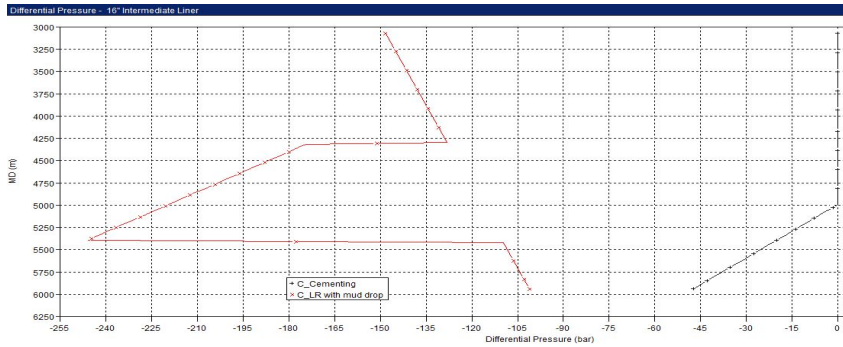
**(B) Hydrocarbons can not be excluded before 13 5/8" is set:**



**(a)** Max shut-in wellhead pressure from DTG (+internal P-profiles for the PTs.) **(b)** Differential pressure for DTG and Pressure Tests.

**Figure D.25:** Internal and differential pressure for DTG - 16in. (WellCat)

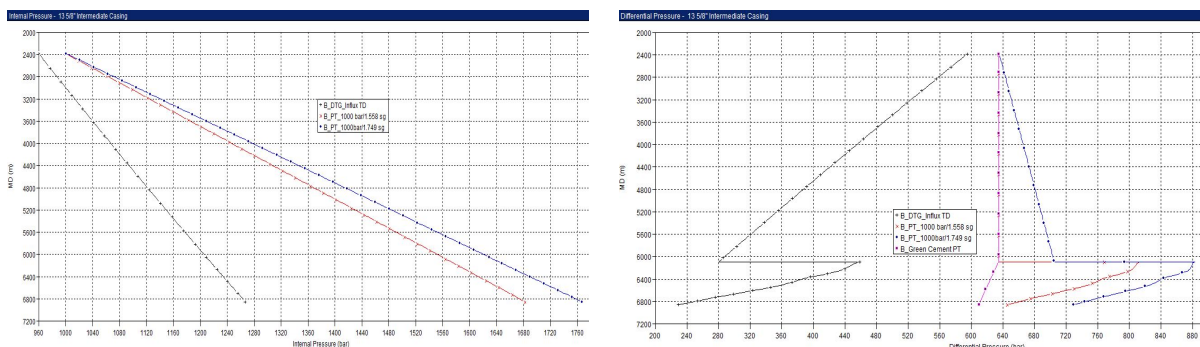
**D.2.3.2 Collapse**



**Figure D.26:** Differential pressure for Lost Returns and Cementing - 16in. (WellCat)

**D.2.4 13 5/8" casing**

**D.2.4.1 Burst**

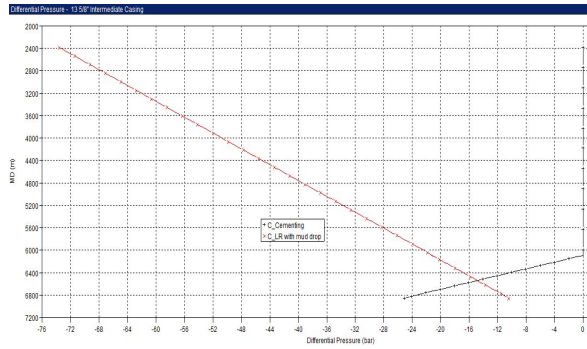


**(a)** Max shut-in wellhead pressure from DTG (+internal P-profiles for the PTs.) **(b)** Differential pressure for DTG and Pressure Tests.

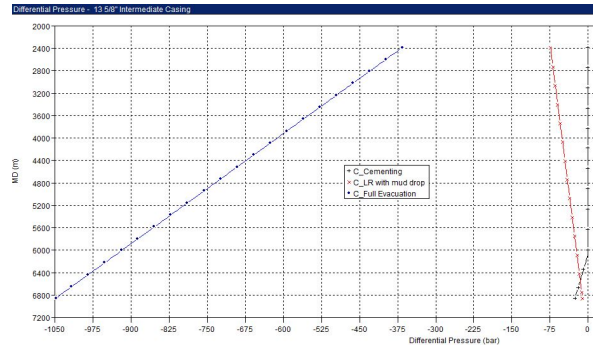
**Figure D.27:** Internal and differential pressure for DTG - 13 5/8in. (WellCat)



### D.2.4.2 Collapse



(a) No Gas Lift - Lost Returns.

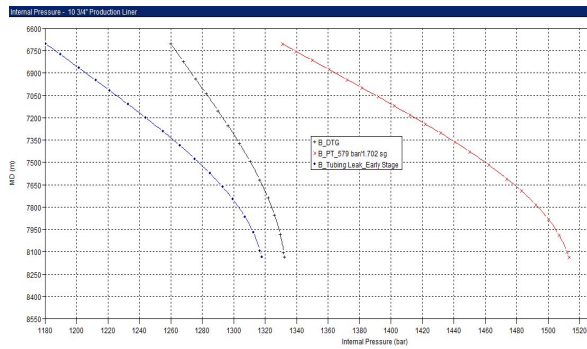


(b) Gas Lift - Full Evacuation 13 5/8".

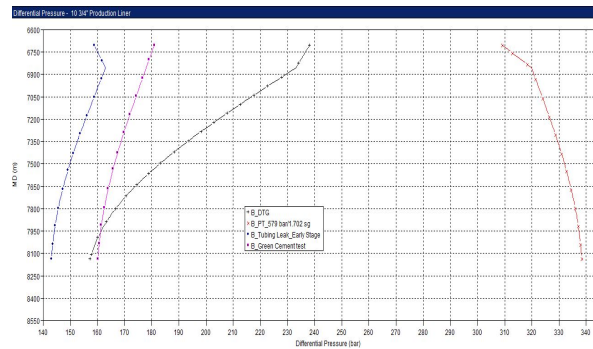
**Figure D.28:** Differential pressure: Lost Returns versus Full Evacuation (No Gas Lift versus Gas Lift) - 13 5/8in. (WellCat)

## D.2.5 10 3/4" liner

### D.2.5.1 Burst



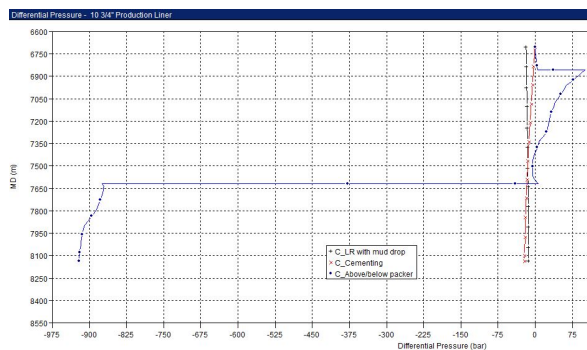
(a) Max shut-in wellhead pressure from DTG (+internal P-profiles for the PTs.)



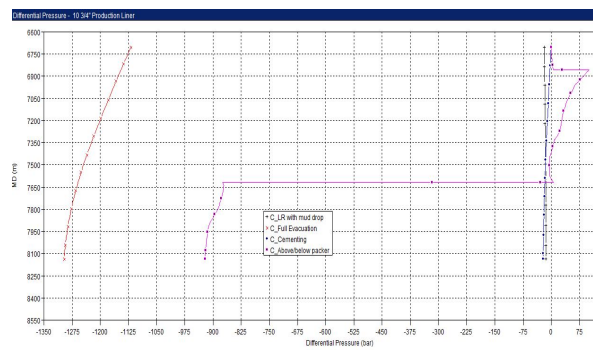
(b) Differential pressure for DTG and Pressure Tests.

**Figure D.29:** Internal and differential pressure for DTG - 10 3/4in. (WellCat)

### D.2.5.2 Collapse



(a) No Gas Lift - Above/below packer.

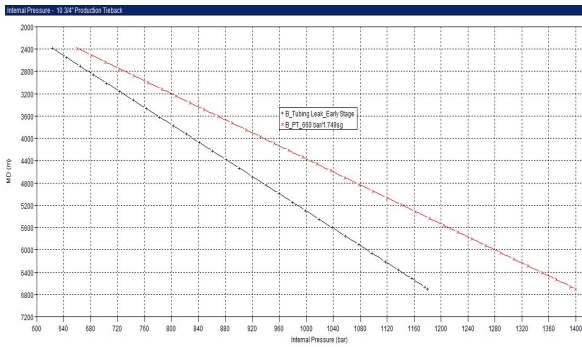


(b) Gas Lift - Full Evacuation 10 3/4".

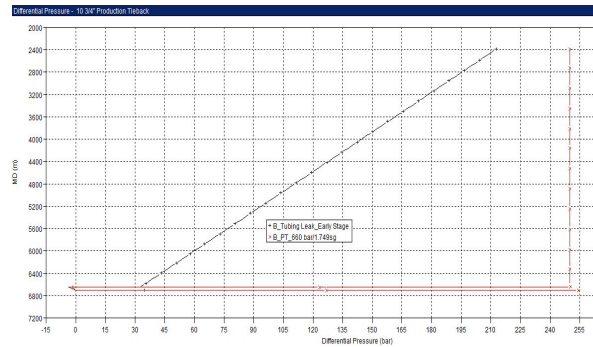
**Figure D.30:** Differential pressure: Above/below packer versus Full Evacuation (No Gas Lift versus Gas Lift) - 10 3/4in. (WellCat)

## D.2.6 10 3/4" tieback

### D.2.6.1 Burst



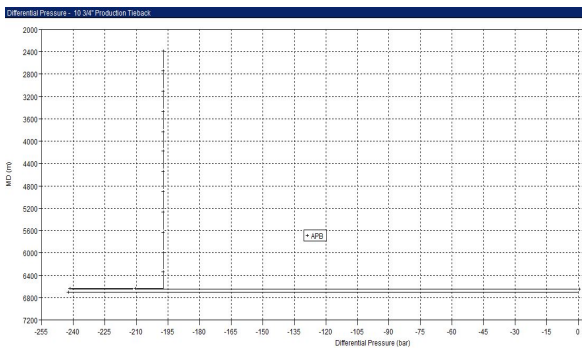
(a) Max shut-in wellhead pressure from Tubing Leak (+internal P-profiles for the PTs.)



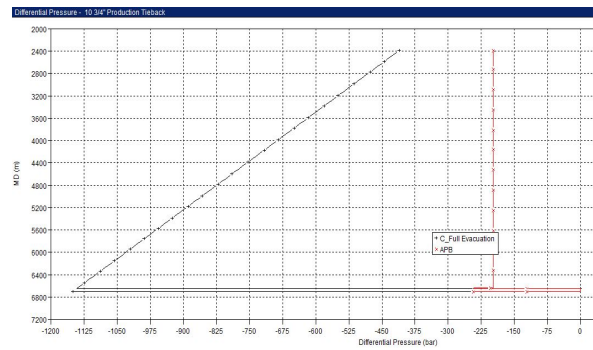
(b) Differential pressure for Tubing Leak and Pressure Tests.

**Figure D.31:** Internal and differential pressure for TL - 10 3/4in tieback. (WellCat)

### D.2.6.2 Collapse



(a) No Gas Lift - APB.

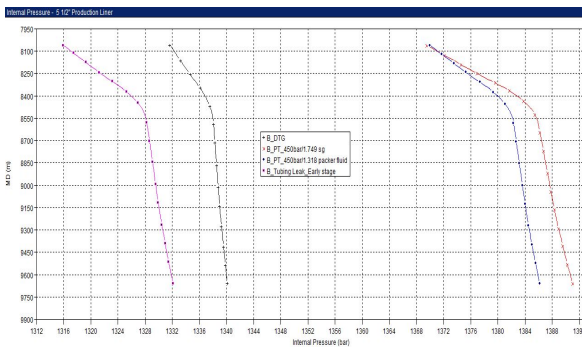


(b) Gas Lift - Full Evacuation 10 3/4" TB.

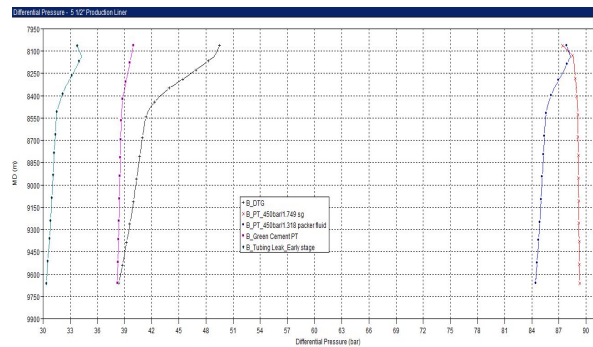
**Figure D.32:** Differential pressure: APB versus Full Evacuation (No Gas Lift versus Gas Lift) - 10 3/4in tieback. (WellCat)

## D.2.7 5 1/2" liner

### D.2.7.1 Burst



(a) Max shut-in wellhead pressure from DTG (+internal P-profiles for the PTs.)



(b) Differential pressure for DTG and Pressure Tests.

**Figure D.33:** Internal and differential pressure for DTG - 5 1/2in tieback. (WellCat)

### D.2.7.2 Collapse

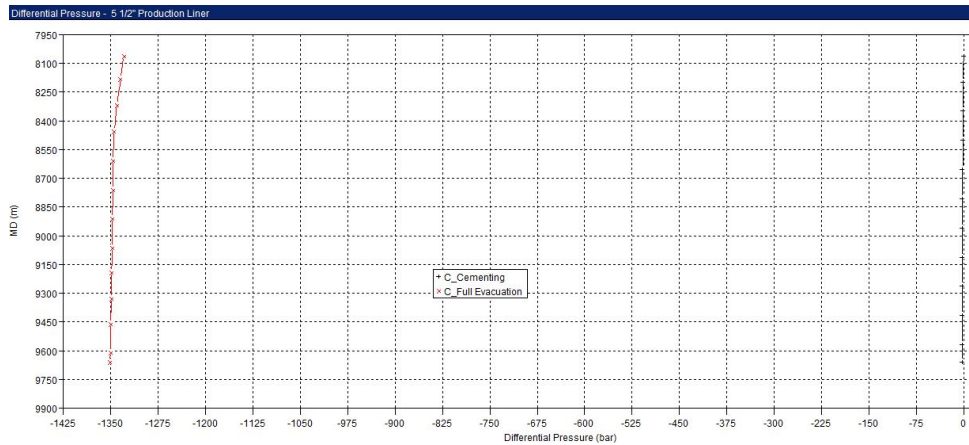


Figure D.34: Including Gas Lift - Full Evacuation - 5 1/2”.

### D.2.7.3 Production Simulations

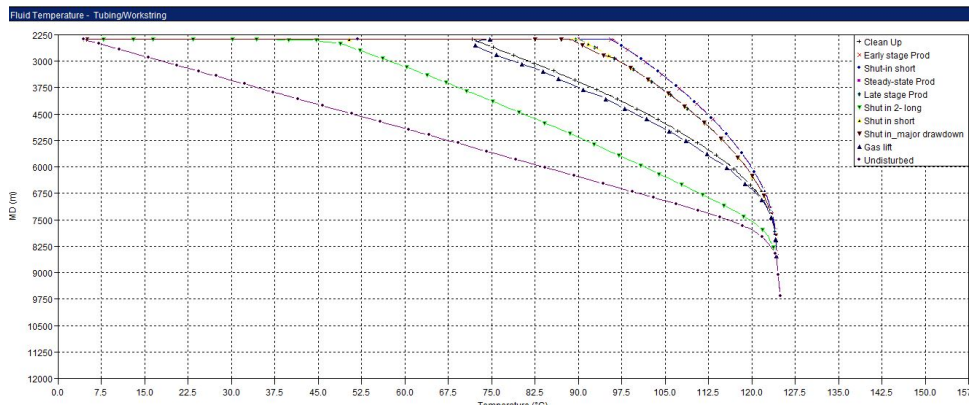


Figure D.35: Fluid temperature from production (WellCat)

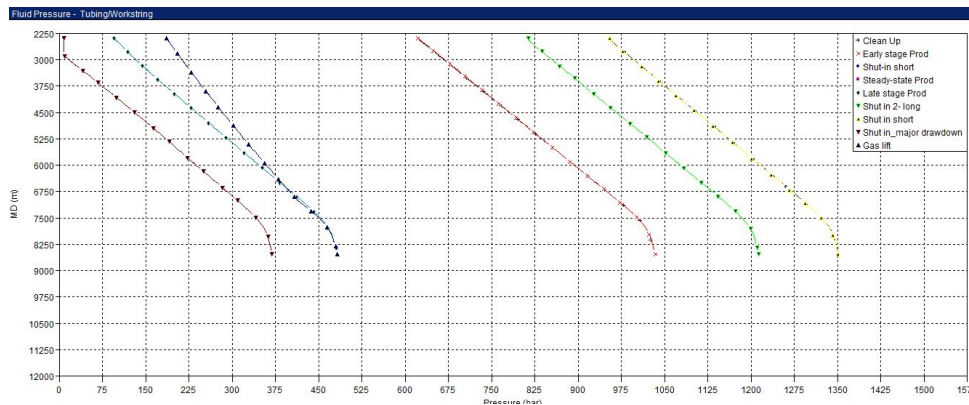
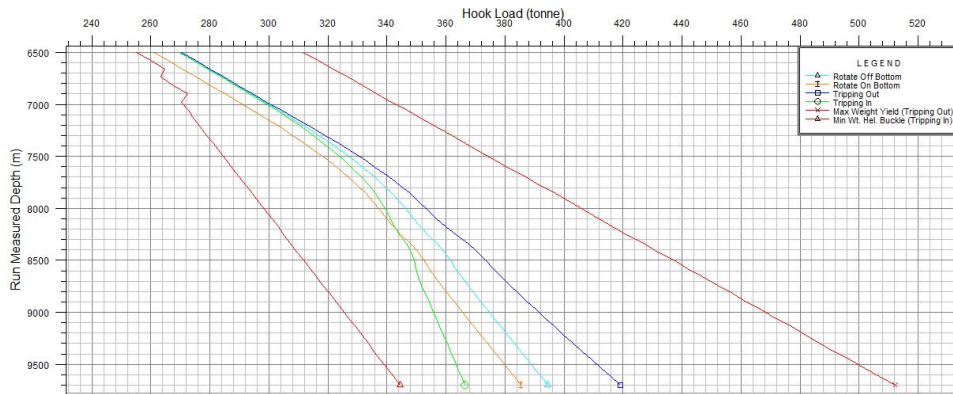


Figure D.36: Fluid pressure from production (WellCat)

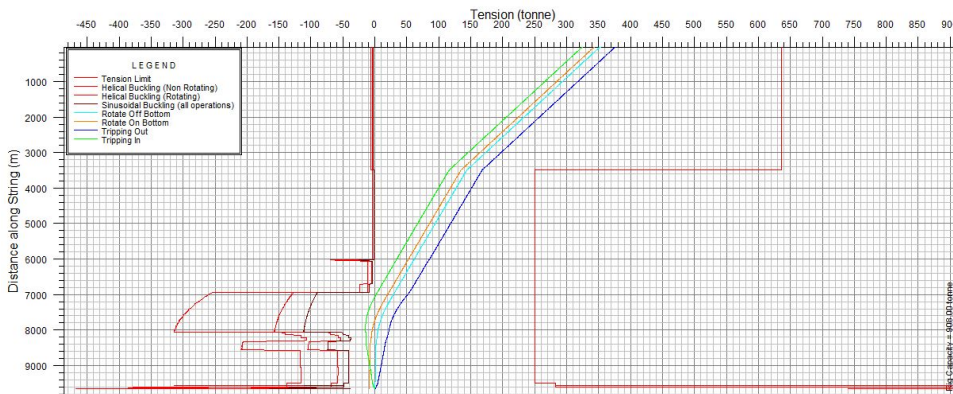
## D.3 WellPlan Simulation

### D.3.1 Case Study Simulations

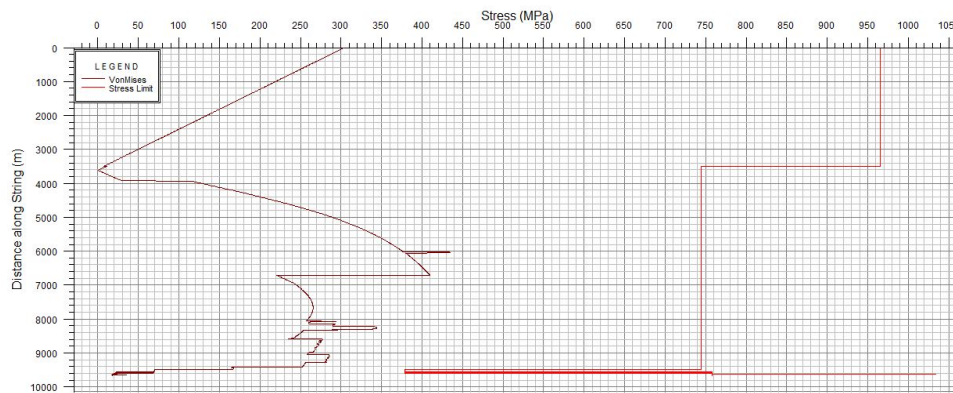
#### D.3.1.1 Drilling 8 1/2" Hole



**Figure D.37:** Hook Load - Drilling 8 1/2" Hole (WellPlan)



**Figure D.38:** Tension - Drilling 8 1/2" Hole (WellPlan)



**Figure D.39:** Von Mises Stress - Drilling 8 1/2" Hole (WellPlan)

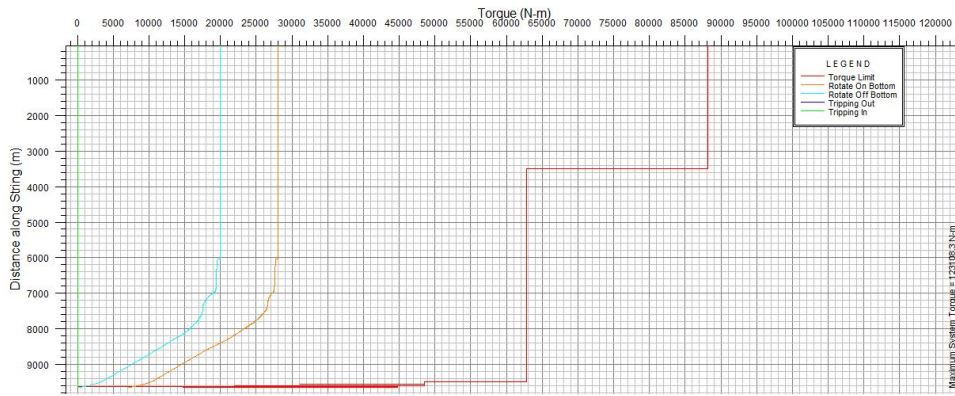


Figure D.40: Torque - Drilling 8 1/2" Hole (WellPlan)

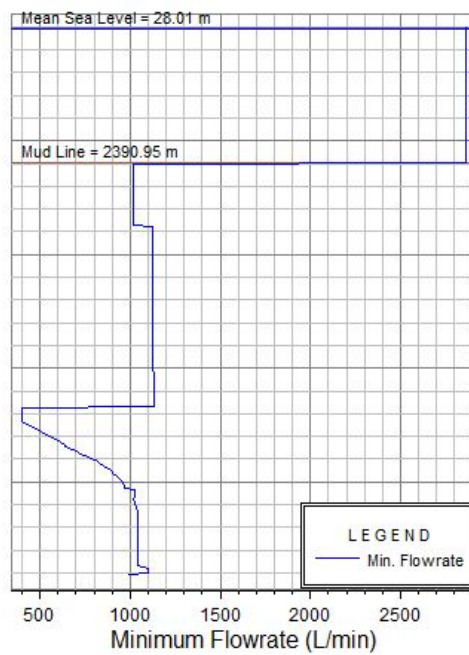


Figure D.41: Minimum Flow Rate - Drilling 8 1/2" Hole (WellPlan)

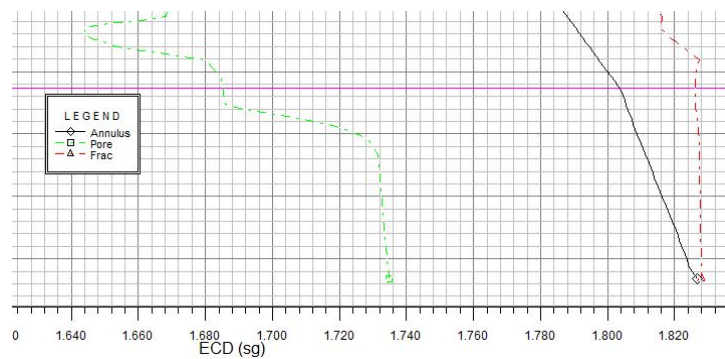


Figure D.42: ECD using 1650lpm - Drilling 8 1/2" Hole (WellPlan)

D.3.1.2 Running 5 1/2" Liner

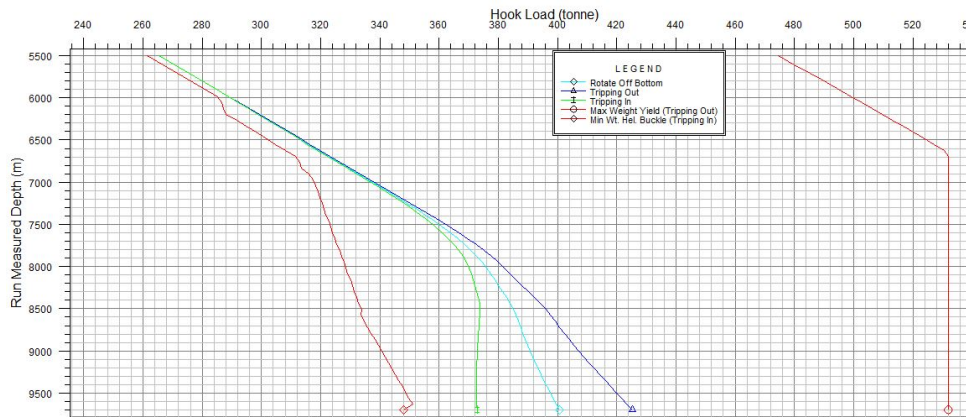


Figure D.43: Hook Load - Running 5 1/2" Liner (WellPlan)

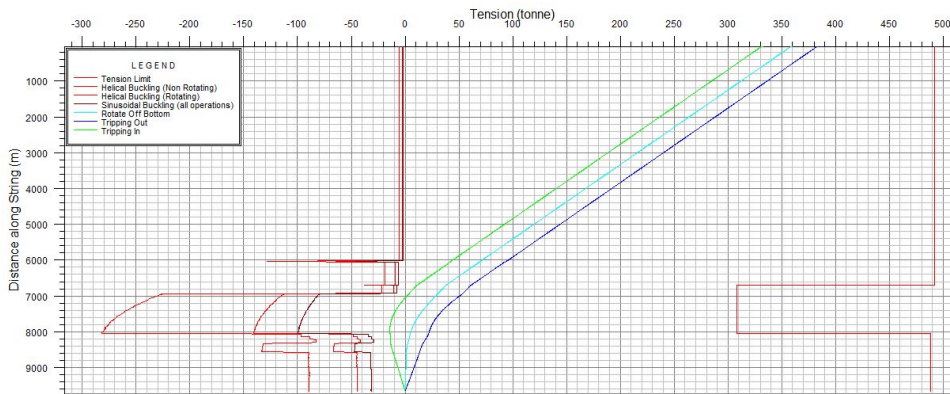


Figure D.44: Tension - Running 5 1/2" Liner (WellPlan)

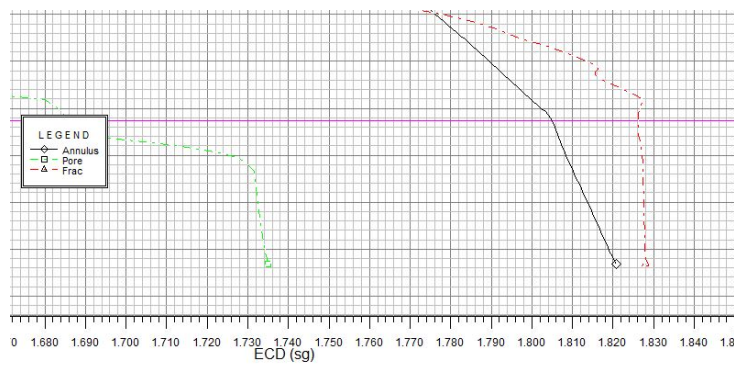


Figure D.45: ECD using 1800lpm - Running 5 1/2" Liner (WellPlan)

### D.3.1.3 Cementing 5 1/2" Liner

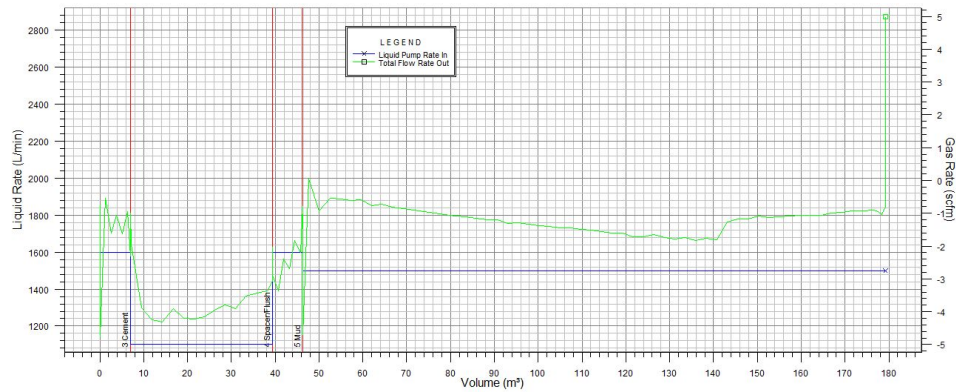


Figure D.46: Resulting Rates - Cementing 5 1/2" Liner (WellPlan)

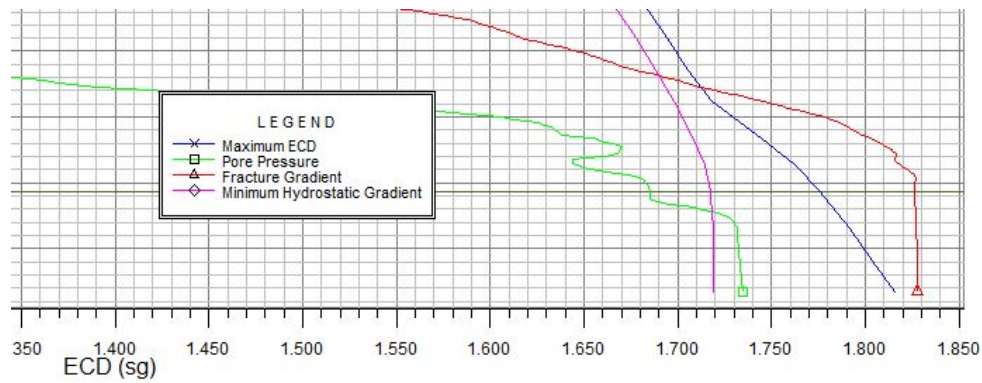
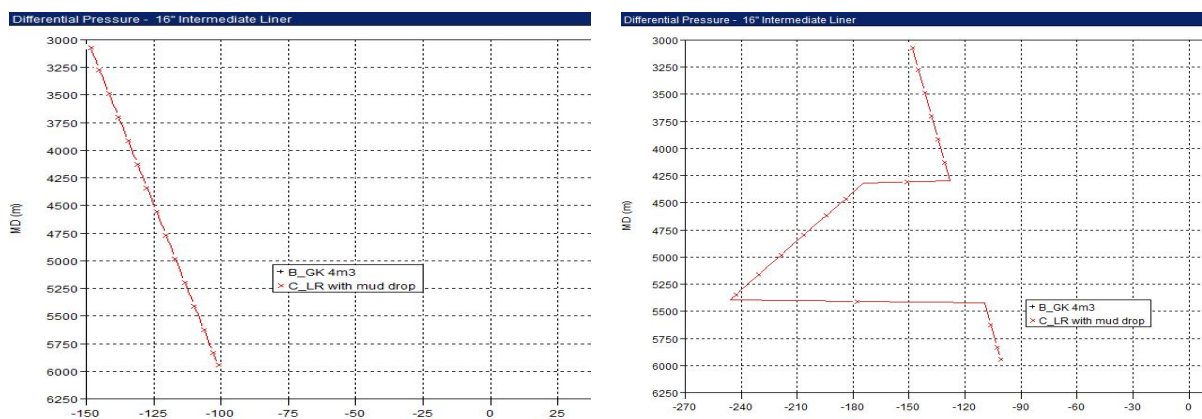


Figure D.47: ECD - Cementing 5 1/2" Liner (WellPlan)

## D.4 Sensitivity Simulation



(a) No salt formations

(b) Including salt formations

Figure D.48: Differential pressure 16" - With/without salt formations

# Appendix E

## Literature Study - Additional Information

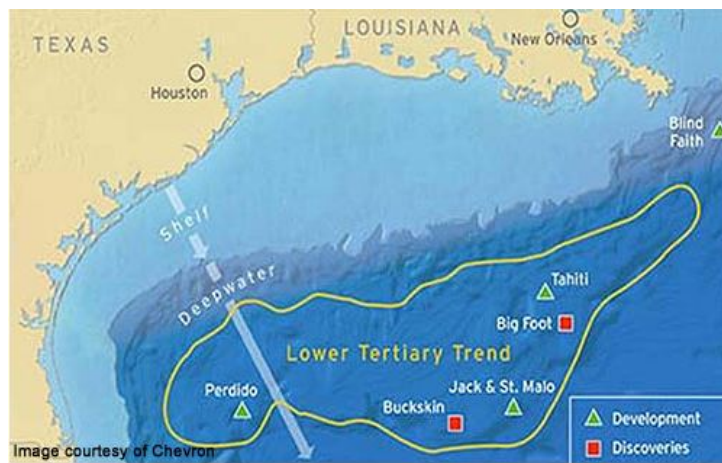
*Table E.1: Examples of barrier systems through the life of the well. (Bellarby, 2009)*

Example	Primary Barrier	Secondary Barrier
Drilling a well	Overbalanced mud capable of building a filter cake	Casing/wellhead and BOP
Running the upper completion	Isolated and tested reservoir completion, for example inflow-tested cemented liner or pressure-tested isolation valve	Casing/wellhead and BOP
Pulling the BOP	Packer and tubing  Isolated reservoir completion, for example deep-set plug	Casing, wellhead and tubing hanger  Tubing hanger plug. Possible additional barrier of downhole safety valve
Operating a naturally flowing well	Christmas tree Downhole safety valve	Packer and tubing Casing, wellhead and tubing hanger
Operating a pumped well not capable of flowing naturally	Christmas tree or surface valve Casing and wellhead	Pump shut-down
Pulling a completion	Isolated and tested reservoir completion, for example deep-set plug and packer/overbalanced mud	Casing/wellhead and BOP



**Table E.2:** API grades and strengths from API 5CT(2005). (Bellarby, 2009)

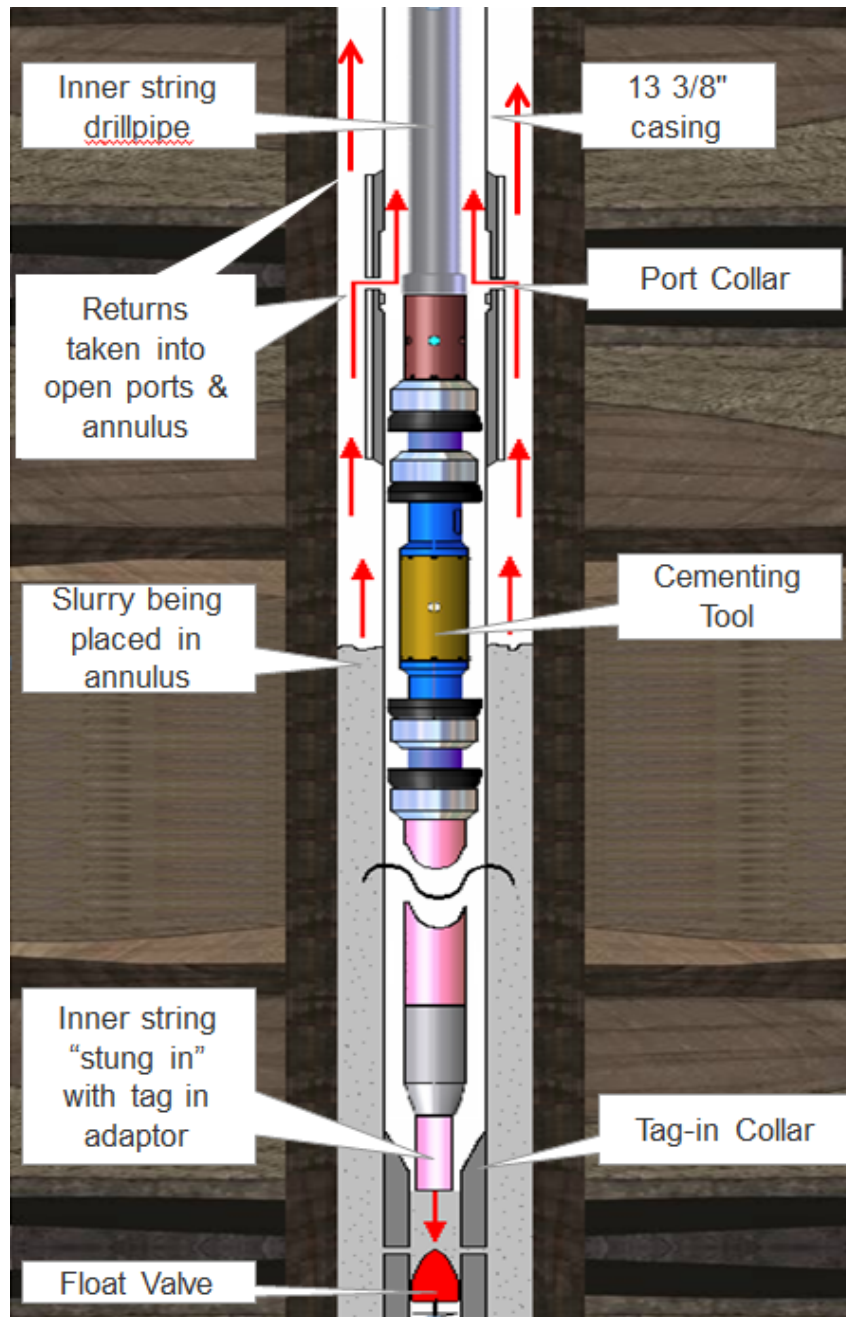
Group	Grade	Elongation Under Load (%)	Yield Stress (ksi)		Minimum Tensile Strength (ksi)	Maximum Hardness (Rockwell C)
			Minimum	Maximum		
1	H40	0.5	40	80	60	—
	J55	0.5	55	80	75	—
	K55	0.5	55	80	95	—
	N80	0.5	80	110	100	—
2	M65	0.5	65	85	85	22
	L80	0.5	80	95	95	23
	L80	0.5	80	95	95	23
	L80	0.5	80	95	95	23
	C90	0.5	90	105	100	25.4
	C95	0.5	95	110	105	—
	T95	0.5	95	110	105	25.4
	P110	0.6	110	140	125	—
4	Q125	0.65	125	150	135	—

**Figure E.1:** Water depths in the GoM. (Rigzone, n.d., a)

**Table E.3:** *Alternate path versus circulating open hole gravel packs. (Bellarby, 2009)*

	<b>Alternate Path</b>	<b>Circulating Pack</b>
Gravel pack fluids	Water (or oil) with viscosifiers. Viscous fluids may not clean up and require more quality control.	Water used with friction reducers and additives.
Slurry density	Higher concentrations: around 8 ppa.	Typically 0.5-2 ppa.
Fluid volume and time	Higher slurry concentrations require lower fluid volumes and reduced pumping times.	Correspondingly larger fluid volumes as gravel concentration is reduced.
Fluid loss	Complete returns not needed. Possible without any returns.	Poor returns will lead to premature screen out.
Pressures	Can exceed fracture pressure.	Must not exceed fracture initiation pressure.
Hole condition	Less critical.	Critical washouts or previous casing rat hole may cause premature screen out.
Filter cake removal	Low consequences and can be encouraged. May not need separate circulation and spotting of breakers.	If filter cake removed, can screen out due to losses. Filter cake removed after gravel packing.
Screen size	Smaller base pipe screen, but larger overall diameter to accommodate shunts.	Larger base pipe screens possible for a given hole size.
Cost	Less time, but more (and expensive) chemicals.	More rig time for pumping.





**Figure E.3:** C-flex tool. (Archer, n.d.)

# Appendix F

## Software

The high T&D values experienced in complex ERW requires extensive planning to keep within the limits of the equipment. T&D modelling is an important part of this planning. The models are important to avoid drilling problems and to make sure the target is reachable. Landmark's Compass<sup>TM</sup> and Wellplan<sup>TM</sup> are software used for this purpose.

### F.1 Compass<sup>TM</sup>

Compass<sup>TM</sup> is a directional well planning software developed by Landmark. It is used for path planning, survey data management, and anti-collision analysis. The software is deployed on Landmark's Engineer's Data Model<sup>TM</sup> (EDM) enabling data consistency and reduced planning cycle times by sharing common data. (Halliburton, c)

### F.2 Wellplan<sup>TM</sup>

Wellplan<sup>TM</sup> gives a comprehensive set of engineering tools for analysis, well planning, modelling, and well operations optimization. It is deployed on Landmark's EDM. The main focus in this report will be on Torque and Drag (T&D) models and hydraulics models.

Wellplan<sup>TM</sup> Torque and Drag Analysis software allows identification of potential problems during planning, and supplies tools to investigate design modifications for improvement. In addition, it can be used to determine if the selected rig has adequate mechanical specifications to handle well design requirements. Wellplan<sup>TM</sup> Hydraulics software have all the necessary tools to study and design well hydraulics. Equivalent circulating densities with regards to pore and fracture pressure problems, and flow rate selection to optimize hole cleaning, are two of the possible studies that can be done. (Halliburton, d)

### F.3 WellCat<sup>TM</sup>

Most companies demand extensive simulations of casing and tubing design when working with high pressure, high temperature (HPHT) wells. Landmarks's WellCat provides an excellent tool to do these simulations. It is a Comprehensive Tubular Stress Analysis Software and allows for complex HPHT conditions modelling and design options, to achieve the best casing and tubular design. (Halliburton, a)

High temperature and high annular pressure are characteristics in deep water, and can cause the casing to burst or collapse. WellCat provides good tools for analysing these stresses and which effect they will have on the design. Thermal effects is also widely covered. (Halliburton, a)