



NTNU – Trondheim
Norwegian University of
Science and Technology

Managing pressure during underbalanced drilling

Jostein Råen

Earth Sciences and Petroleum Engineering

Submission date: May 2012

Supervisor: John-Morten Godhavn, IPT

Norwegian University of Science and Technology

Department of Petroleum Engineering and Applied Geophysics

Problem description

Background

Several parameters can be adjusted to control the bottom hole pressure during underbalanced drilling. The candidate studied mathematical models of well bore multiphase hydraulics. In this MSc work the study will focus on simulation studies using a multiphase drilling simulator from SPT. Several cases shall be defined, and the candidate shall demonstrate how the down-hole pressure and influx can be controlled.

Work description

1. Literature study: Detail use of simulator. Define measurements and inputs needed to control the down-hole pressure.
2. Case studies: run simulations on 2 or more wells including
 - a. Normal drilling
 - b. Tripping
 - c. Connection (separation in annulus?)

Demonstrate the effect on bottom hole pressure and influx rate of adjusting different inputs (choke position, mud and gas rates, etc.)

3. Contingencies:
 - a. Drilling into a high pressure zone, increased influx, increase down-hole pressure to compensate.
 - b. Pump failure with sudden stop of circulation.
4. Discussion: How can we automate underbalanced drilling? Use of standpipe pressure, hydraulic models, quality of data, how to calibrate models and keep them updated, responsibility, manual vs. automatic systems.

Preface

This master thesis is the result of my work during the spring 2012 which is the last semester of my five year master degree study at the Norwegian University of Science and Technology. I have studied petroleum technology with drilling as my main profile so the thesis problem was assigned to me by the Department of Petroleum Engineering and Applied Geophysics. The purpose of this thesis have been to investigate how to control the bottom hole pressure during underbalanced drilling with the help from an advanced multiphase flow simulator.

The thesis is a continuation of my specialization project from the autumn 2011 where I did a literature study about pressure control in underbalanced drilling. In the project I also used a simple multiphase model for calculations of bottom hole pressure.

I would like to thank my supervisor Adjunct Professor John-Morten Godhavn at Department of Petroleum Engineering and Applied Geophysics. He has been a very good support for me during my work and has given me a lot of feedback throughout the semester.

Trondheim May 2012

Jostein Råen

Abstract

Underbalanced drilling has received more and more attention in recent years. The reason for that may be because many oil fields, especially on the Norwegian continental shelf, have started to show signs of aging. By that I mean that the production is going down, and reservoir pressure is more and more reduced. Underbalanced drilling is a technique that is suitable for dealing with these challenges. The major benefits like for example reduced reservoir damage, and the ability to drill through narrow pressure windows, both help in prolonging the life of mature fields.

To be able to perform a successful underbalanced drilling operation control over the pressure in the well is crucial. The bottom hole pressure must be controlled and adjusted as the operation goes on to make sure that underbalanced conditions are maintained at all times. My main goal with this thesis have been to demonstrate how the bottom hole pressure can be controlled by different parameters, and the investigation of different scenarios that can occur during an underbalanced operation and how they affect the bottom hole pressure.

The Drillbench package contains two multiphase flow simulators that are specialized for underbalanced drilling. The Steadyflodrill is a steady-state simulator and the Dynaflodrill is a dynamic simulator. The dominant simulator in my work has been the Dynaflodrill.

During drilling the bottom hole pressure is adjusted and controlled with three different parameters. These are the liquid injection rate, gas injection rate and the choke opening. Which of these parameters that will change the bottom hole pressure the fastest will vary with the type of well being drilled.

Doing a connection during underbalanced drilling can be problematic, but this will vary with the type of reservoir being drilled. Separation of fluids in the wellbore when circulation is halted can cause severe fluctuations in the bottom hole pressure. By using the choke these fluctuations can be reduced to an acceptable level.

Tripping underbalanced also offer challenges regarding separation of fluids which will kill the well after some time since the circulation is stopped for a long period. Also reservoirs containing heavier oil will be killed eventually if the reservoir is under pressured.

Drilling through narrow pressure windows can be problematic if a pump failure should occur. This failure can lead to a sudden drop in the bottom hole pressure which can cause it to drop under the collapse pressure limit of the formation and cause for instance a stuck-pipe situation. Hitting an unexpected high pressure zone can lead to a well control situation due to an increased influx of formation fluids which exceeds the limits of the separator.

Automation of underbalanced drilling has been difficult due to low data transportation rate from the bottom to surface, and difficulties with correct modeling of the multiphase flow in the well. A possibility can be to make use of the pump pressure and make an estimation of the bottom hole pressure based on that and a model of the friction in the drill pipes.

Sammendrag

Underbalansert boring har fått mer og mer oppmerksomhet de siste årene. Grunnen til det kan være at mange oljefelt, spesielt på den norske kontinentalsokkelen, har begynt å vise tegn på aldring. Med det mener jeg at produksjonen går ned og reservoartrykket blir mindre og mindre. Underbalansert boring er en teknikk som er egnet til å håndtere disse utfordringene. Hovedfordelene som for eksempel redusert skade på reservoaret, og muligheten til å bore gjennom trange trykkvindu, hjelper begge til å forlenge livet til modne felt.

For å kunne utføre en vellykket underbalansert boreoperasjon er kontroll over trykket i brønnen avgjørende. Bunnhullstrykket må kontrolleres og justeres gjennom operasjonen for å sørge for at man opprettholder underbalanserte forhold hele tiden. Hovedmålet mitt med denne oppgaven har vært å demonstrere hvordan bunnhullstrykket kan kontrolleres av ulike parametere, og å studere ulike scenarioer som kan oppstå under underbalansert boring og hvordan de påvirker bunnhullstrykket.

Drillbench inneholder to flerfase-strømning simulatorer som er laget for underbalansert boring. Steadyfloddrill er en steady-state simulator mens Dynafloddrill er en dynamisk simulator. I mitt arbeid har Dynafloddrill vært den dominerende simulatoren.

Ved boring er bunnhullstrykket kontrollert og justert med tre ulike parametere. Disse er væske injeksjons rate, gass injeksjons rate og åpningen til choken. Hvilken av disse parameterne som endrer bunnhullstrykket fortest vil variere med den type brønn som blir boret.

Å gjøre en tilkobling av et nytt borerør når man borer underbalansert kan være problematisk, men dette vil variere med hvilken type reservoar som blir boret. Separasjon av fluider i brønnen når sirkulasjonen stoppes kan føre til betydelige svingninger i bunnhullstrykket. Ved å bruke choken kan disse svingningene reduseres til et akseptabelt nivå.

Å trippe underbalansert kan by på utfordringer vedrørende separasjon av fluider som vil føre til at brønnen blir drept etter en viss tid siden sirkulasjonen er stoppet over en lang periode. Også reservoar som inneholder tyngre olje vil bli drept til slutt så lenge reservoaret er «under-trykt».

Å bore gjennom et smalt trykkvindu kan være problematisk dersom det skulle oppstå en feil med pumpene og disse stopper brått. Dette kan føre til et plutselig fall i bunnhullstrykket som kan føre til at det faller under kollapstrykk grensen til formasjonen og forårsake for eksempel en stuck-pipe situasjon. Dersom man treffer en uventet høytrykkssone kan det føre til en brønnskroll situasjon fordi en kraftig økning i influx av formasjonsfluider fra reservoaret kan føre til at strømmen fra brønnen overstiger kapasiteten til separatoren.

Automatisering av underbalansert boring har vært vanskelig på grunn av lav data transport rate fra bunnen til overflaten, og vanskeligheter med korrekt modellering av flerfase-strømning i brønnen. Bruk av wired pipe vil kunne øke data transport raten betraktelig. En mulighet kan være

å bruke pumpetrykket sammen en modell av friksjonen i borerørene for å estimere bunnhullstrykket. Dette estimerte trykket kan brukes til å kontrollere choken.

Table of Contents

Problem description.....	I
Preface.....	III
Abstract.....	V
Sammendrag.....	VII
List of Figures.....	XIII
List of Tables.....	XV
1. Introduction.....	1
2. Introduction to underbalanced drilling.....	3
2.1. Definition.....	3
2.2. Advantages with UBD.....	3
2.2.1. Minimizing drilling problems.....	4
2.2.2. Maximizing hydrocarbon recovery.....	4
2.2.3. Characterize/evaluate the reservoir.....	5
2.3. Possible problems/disadvantages with UBD.....	5
2.3.1. Borehole stability problems.....	5
2.3.2. Safety issues due to high pressure reservoirs.....	5
2.3.3. Use of MWD.....	6
2.3.4. Failure to maintain a continuous under-balance in the well.....	6
2.3.5. Cost of UBD operation.....	6
2.4. Equipment.....	6
2.4.1. Overview of a normal UBD equipment setup.....	6
2.4.2. Choke system.....	7
2.4.3. Separator system.....	8
2.4.4. Rotating control device.....	9
2.4.5. Mud – gas injection systems.....	10
2.5. Planning and modeling of a UBD operation.....	12
2.5.1. Bottom hole pressure.....	12
2.5.2. Pressure differential.....	12
2.5.3. Drilling fluids.....	12
2.5.4. Bottom hole pressure operating area.....	13

3.	Bottom hole pressure control	15
3.1.	Adjustment of the bottom hole pressure.....	15
3.1.1.	The hydraulic model.....	16
3.1.2.	Adjustment of BHP with the choke.....	17
3.1.3.	Adjustment of BHP with gas injection rate.....	17
3.1.4.	Adjustment of BHP with liquid injection rate.....	18
4.	Dynaflodrigill.....	19
4.1.	Theoretical background	19
4.2.	Use of the simulator.....	21
4.2.1.	Basic input.....	21
4.2.2.	Expert input.....	24
4.2.3.	Simulation	25
4.3.	Steadyflodrigill	26
5.	Case studies.....	29
5.1.	Drilling.....	29
5.1.1.	Under pressured well.....	29
5.1.2.	Over pressured well.....	34
5.1.3.	Conclusion.....	37
5.1.4.	Liquid holdup	38
5.2.	Connection.....	39
5.2.1.	Over pressured well.....	40
5.2.2.	Under pressured well.....	44
5.2.3.	Conclusion.....	58
5.3.	Tripping	59
5.3.1.	Challenges	59
5.3.2.	Conclusion.....	67
6.	Narrow pressure window	71
6.1.	Pump failure	71
6.2.	UBD vs. MPD.....	74
7.	Unexpected high pressure zone.....	77
8.	Automation of BHP control.....	85

9. Conclusion	89
10. Abbreviations	91
11. References	93

List of Figures

Figure 2.1 Drilling pressure window (Eck-Olsen, 2010)	3
Figure 2.2 Surface equipment (Saponja, 1998).....	7
Figure 2.3 Choke design (Eck-Olsen, 2003)	8
Figure 2.4 4-phase separator (Eck-Olsen, 2003).....	9
Figure 2.5 RTI RBOP (Eck-Olsen, 2010)	10
Figure 2.6 Gas injection methods (Eck-Olsen, 2003)	12
Figure 2.7 UBD operating envelope	14
Figure 3.1 Annular friction pressure	16
Figure 3.2 Gas injection rate vs. BHP (Saponja, 1998)	18
Figure 4.1 Basic input Dynaflo-drill.....	22
Figure 4.2 Expert input Dynaflo-drill.....	24
Figure 4.3 Simulation window Dynaflo-drill	25
Figure 4.4 Graph Steadyflo-drill	26
Figure 5.1 BHP vs gas injection rate	30
Figure 5.2 BHP under pressured well – drilling.....	31
Figure 5.3 Influx under pressured well - drilling	31
Figure 5.4 Liquid rate in/out under pressured well - drilling	32
Figure 5.5 Free gas before and after choke closing under pressured well - drilling	34
Figure 5.6 BHP over pressured well – drilling.....	35
Figure 5.7 Influx over pressured well - drilling	36
Figure 5.8 Free gas before and after choke closing over pressured well - drilling	37
Figure 5.9 Free gas - liquid holdup	39
Figure 5.10 BHP over pressured well - connection	40
Figure 5.11 Influx over pressured well – connection.....	41
Figure 5.12 Liquid rate in/out over pressured well – connection.....	41
Figure 5.13 Choke opening over pressured well – connection	42
Figure 5.14 Free gas before and after stopping pump over pressured well - connection.....	43
Figure 5.15 BHP - separation of fluids	45
Figure 5.16 Influx - separation of fluids	45
Figure 5.17 Liquid rate in/out - separation of fluids	46
Figure 5.18 Free gas before and after separation	47
Figure 5.19 Pressure in annulus before and after separation.....	48
Figure 5.20 Slug moving up the annulus.....	49
Figure 5.21 BHP during slugging	50
Figure 5.22 Free gas after first and second separation - slugging.....	51
Figure 5.23 BHP - slugging avoided.....	53
Figure 5.24 BHP-reducing slugging with choke.....	53
Figure 5.25 Choke opening-reducing slugging with choke	54
Figure 5.26 BHP - mitigating separation with choke.....	55

Figure 5.27 Choke pressure - mitigating separation with choke.....	56
Figure 5.28 Choke opening - mitigating separation with choke	56
Figure 5.29 Liquid rate in/out - mitigating separation with choke.....	57
Figure 5.30 BHP - tripping.....	60
Figure 5.31 Influx - tripping.....	60
Figure 5.32 Free gas in the well during tripping	61
Figure 5.33 Pressure in annulus before and after separation - tripping.....	62
Figure 5.34 BHP - tripping heavy oil.....	63
Figure 5.35 Influx - tripping heavy oil.....	63
Figure 5.36 Liquid rate in/out - well with separation.....	64
Figure 5.37 Liquid rate in/out - well with heavy oil	65
Figure 5.38 Formation oil in annulus - well with separation	66
Figure 5.39 Formation oil in annulus - well with heavy oil.....	67
Figure 5.40 BHP - well with separation - starting circulation after tripping.....	68
Figure 5.41 BHP - well with heavy oil - starting circulation after tripping	69
Figure 5.42 BHP parasite gas injection.....	70
Figure 6.1 BHP - narrow pressure window - pump failure.....	72
Figure 6.2 BHP - narrow pressure window - mitigating pump failure.....	73
Figure 6.3 Choke opening - mitigating pump failure.....	74
Figure 6.4 Narrow pressure window-illustration	75
Figure 7.1 Well control matrix (Ramalho and Davidson, 2006).....	78
Figure 7.2 BHP - drilling into high pressure zone	79
Figure 7.3 Influx - drilling into high pressure zone	80
Figure 7.4 Liquid rate in/out - drilling into high pressure zone	80
Figure 7.5 Gas rate out - drilling into high pressure zone.....	81
Figure 7.6 Gas rate out - drilling further into high pressure zone.....	82
Figure 7.7 BHP -drilling further into high pressure zone	83
Figure 7.8 Pressure in annulus - drilling further into high pressure zone	83
Figure 8.1 Friction pressure	87
Figure 8.2 Estimated BHP.....	88

List of Tables

Table 4.1 Parameters in simulator equations20
Table 5.1 Experiment values under pressured well.....30
Table 5.2 Experiment values over pressured well.....34
Table 5.3 Parameters - realistic separation case.....55

1. Introduction

Underbalanced drilling has received more and more attention in recent years. The reason for that may be because many oil fields, especially on the Norwegian continental shelf, have started to show signs of aging. By that I mean that the production is going down, and reservoir pressure is more and more reduced. Underbalanced drilling is a technique that is suitable for dealing with these challenges. The major benefits like for example reduced reservoir damage, and the ability to drill through narrow pressure windows, both help in prolonging the life of mature fields. Also the reduction of other drilling problems, like the elimination of differential sticking, and the increased rate of penetration contribute to enhance the drilling process.

To be able to perform a successful underbalanced drilling operation control over the pressure in the well is crucial. The bottom hole pressure must be controlled and adjusted as the operation goes on to make sure that underbalanced conditions are maintained at all times. If you are unable to keep the well underbalanced during the entire operation the benefits with the technique will be significantly reduced. To achieve control over the bottom hole pressure the correct equipment and procedures must be used. Several parameters can be manipulated to change the bottom hole pressure, and the correct combination of these must be applied to obtain a good result.

My main goal with this thesis is to demonstrate how the bottom hole pressure and reservoir influx can be controlled by manipulation of different parameters. Investigating scenarios that can occur during normal drilling operations, like making a connection or tripping in or out of the hole, will be an important part of my work. I will also look into what can happen when drilling through so-called narrow pressure windows, and if one should enter an undetected high pressure zone. A discussion about how to achieve a more automated drilling process will also be included in this thesis.

To achieve my goals I am going to use a steady-state multiphase drilling simulator called Steadyflodrill, and a dynamic multiphase drilling simulator named Dynaflodrill. Both these simulators are modules in the Drillbench program package delivered by the SPT group. The dynamic simulator will be the dominating tool in my work since I will be dependent on looking at how parameters change with time to achieve my goals with this thesis. I will use the Dynaflodrill simulator to illustrate several scenarios that can occur during different aspects of an underbalanced drilling operation, like for instance separation of fluids in the wellbore. The simulator will also be used to investigate unforeseen events like the mentioned equipment failure.

2. Introduction to underbalanced drilling

2.1. Definition

The definition of underbalanced drilling stated by the IADC Underbalanced Operations committee is: “Drilling with the hydrostatic head of the drilling fluid intentionally designed to be lower than the pressure of the formations being drilled. The hydrostatic head of the fluid may naturally be less than the formation pressure, or it can be induced. The induced state may be created by adding natural gas, nitrogen, or air to the liquid phase of the drilling fluid. Whether the underbalanced status is induced or natural, the result may be an influx of formation fluids which must be circulated from the well and controlled at the surface.” In terms of pressure, underbalanced drilling can be described with the following equation:

$$P_{formation} > P_{BHP} = P_{mud} + P_{friction} + P_{choke} \quad (\text{Aadnoy et. al., 2009}) \quad (2.1)$$

The main differences between underbalanced drilling (UBD) and conventional overbalanced drilling (OBD) are that the drilling mud doesn't act as a barrier against the formation pressure, and that you allow influx of formation fluids into the well. In addition there are many other differences that develop from these two main differences. **Figure 2.1** shows the operating area for underbalanced drilling, which is below the pore pressure and above the collapse pressure.

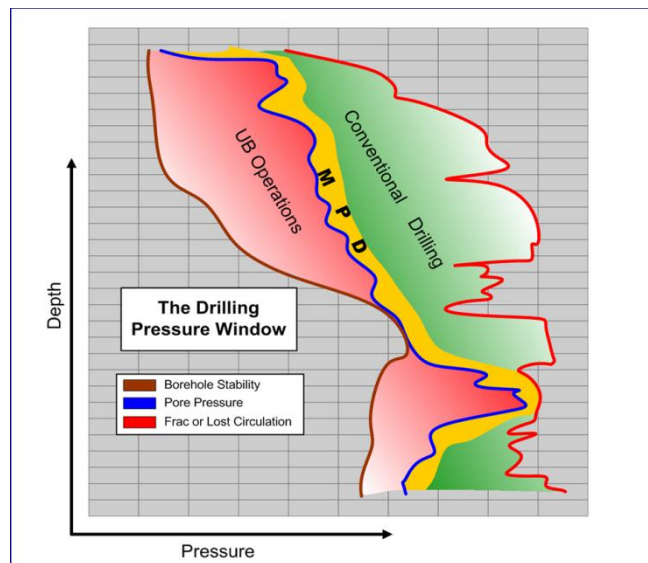

Figure 2.1 Drilling pressure window (Eck-Olsen, 2010)

2.2. Advantages with UBD

The advantages with UBD can be divided into three main categories. (Aadnoy et. al., 2009)

- Minimizing drilling problems
- Maximizing hydrocarbon recovery
- Characterize/evaluate the reservoir

2.2.1. Minimizing drilling problems

2.2.1.1. Narrow pressure window

In some formations the difference between the pore pressure and the fracture pressure is very small. This can be natural or it can be caused by for example fluid injection. (Eck-Olsen et. al.,2004) We have what we call a narrow drilling window as illustrated in the lower part of **Figure 2.1**. In such situations conventional overbalanced drilling can be very difficult to perform. Small variations in your bottom hole pressure (BHP) can cause either fracturing of the formation and mud losses, with possibility for well control issues, or you can get a kick due to too low pressure. If you drill underbalanced you can avoid these problems. You will not get any mud losses since you always have a BHP lower than the fracture pressure limit. Since you have appropriate equipment to handle the continuous influx from the reservoir this will not be a problem either.

2.2.1.2. Differential sticking

UBD will eliminate the differential sticking problem. Differential sticking is caused by a pressure differential between the well and the formation. When the pressure in the well is higher than the formation and you have a mud cake to transmit the pressure differential to the formation, you can get stuck, especially in deviated holes where the drill string is resting on the lower side of the wellbore. Since you have neither an overbalance nor a mud cake when you drill underbalanced you avoid this problem. (Aadnoy et. al., 2009)

2.2.1.3. Increased rate of penetration

You will get an increased rate of penetration (ROP) with UBD. The pressure in the formation and the flow coming from it will make it easier to drill “loose” the cuttings so that the drilling will go faster. Since you often drill with solids free mud you will get reduced wear on the bit. In some hard rock formations you can obtain a significantly higher ROP with UBD. This reduces the time needed for drilling the well, and thus the total cost of the well. (Aadnoy et. al., 2009)

2.2.2. Maximizing hydrocarbon recovery

When you drill conventionally with an overbalanced pressure in the well you will get some invasion of mud into the formation you are drilling. The amount will depend on how well designed the mud system is. This mud inside the formation, also called mud filtrate, can reduce the absolute permeability of the reservoir, the relative permeability of hydrocarbons or change the viscosity of formation fluids. (Aadnoy et. al., 2009) Since you keep the pressure in the well under the pore pressure when you drill underbalanced you can't get any mud loss to the formation. There is also no establishment of a mud cake during UBD. This leads to a faster production from your reservoir and in many cases also a higher recovery factor. Since you have

no formation damage you will not have to pay for expensive stimulation programs, like for example acid treatment, before initiating production. (Bennion, 1999) Underbalanced drilling lets you, as mentioned above, drill more wells into depleted fields. This helps you to recover reserves that you wouldn't have been able to with conventional drilling. (Aadnoy et. al., 2009)

2.2.3. Characterize/evaluate the reservoir

Since you have a continuous influx of formation fluids into the well when you drill a reservoir underbalanced you can obtain valuable information about reservoir permeability, fluid types and rates, reservoir pressure, inflow performance and interval production. This can help you in planning of the length and shape of the well, and give you a better understanding of the reservoir. (Saponja, 1998)

2.3. Possible problems/disadvantages with UBD

There can be some disadvantages tied to under balanced drilling. These problems are often the result of a poorly planned and executed UBD process, and can many times be mitigated by good planning and designing.

2.3.1. Borehole stability problems

One of the most common problems in UBD is borehole stability problems due to the low pressure in the well. If there is a narrow window between the pore pressure and the collapse pressure and you are trying to drill underbalanced you can easily get below the collapse border and your hole will collapse. This can particularly be a problem if you are drilling in a depleted reservoir and you have to have a very low pressure in your well to stay underbalanced. Borehole instability problems can also be caused by fluctuations in the bottom hole pressure, gas influx from the formation, drill-string movement, connections and high annular velocity of the circulating fluid. High annular velocities can cause washout of the borehole wall. The way to mitigate borehole problems is normally to case of shale zones that is likely to cause problems and trying to keep the bottom hole pressure as stable as possible. There are prediction models available for analyzing borehole stability problems and these should be used in the planning of the well. (Saponja, 1998)

2.3.2. Safety issues due to high pressure reservoirs

When you drill underbalanced you are not trying to conceal the pore pressure in the formation by creating an overbalance in the hole, instead you are letting the well flow to the surface. The safety issue then changes from a pressure issue to a flow issue. In reservoirs with very high pressure and permeability there can be safety issues due to large influx of formation fluids. You must have equipment on the surface that is able to handle the expected amount of fluid. The safety problem occurs if you hit high pressure or high permeability zones you were not expecting. Then there will be problems with fluid handling at the surface if you have not planned your equipment with sufficient contingency.

2.3.3. Use of MWD

In UBD you must often use gas or gasified mud as your drilling fluid. The conventional MWD is dependent on a non – compressible fluid as a signal transmitter, and will then not work properly in a compressible fluid like gas. This problem can be avoided by the use of EM MWD – electromagnetic MWD, or wired drill pipe. (Graham, 2011)

2.3.4. Failure to maintain a continuous under-balance in the well

If you are not able to keep a continuous under-balance in the well it can lead to severe formation damage due to invasion of drilling fluid into the formation. Since you don't have a mud cake when you drill underbalanced the formation damage most likely will be much worse than the damage caused by a normal overbalanced drilling operation. The reason for getting into over-balance can be things like making connections, bit trips or local undetected depletion zones. (Bennion, 1999)

2.3.5. Cost of UBD operation

A UBD operation is significantly more expensive than a conventional OBD operation. The reason for that are all the extra equipment needed and the more comprehensive planning process. This is perhaps the most common reason for not drilling underbalanced. The cost of the UBD operation must be weighed against the benefits it can provide before you make a decision. If it is possible to obtain a good result with conventional drilling this method should be chosen. Another alternative is to use managed pressure drilling (MPD) which in many cases can be less expensive and provide very good results.

2.4. Equipment

2.4.1. Overview of a normal UBD equipment setup

Figure 2.2 is showing a normal setup of a UBD operation, and gives an overview of what equipment that is normally needed on the top of the well/surface. The information in this chapter, if not stated otherwise, is obtained from the IADC Rigpass for Statoil from 2003 used in training before drilling underbalanced at the Gullfaks field. Below I have described the most important equipment needed in an underbalanced drilling operation.

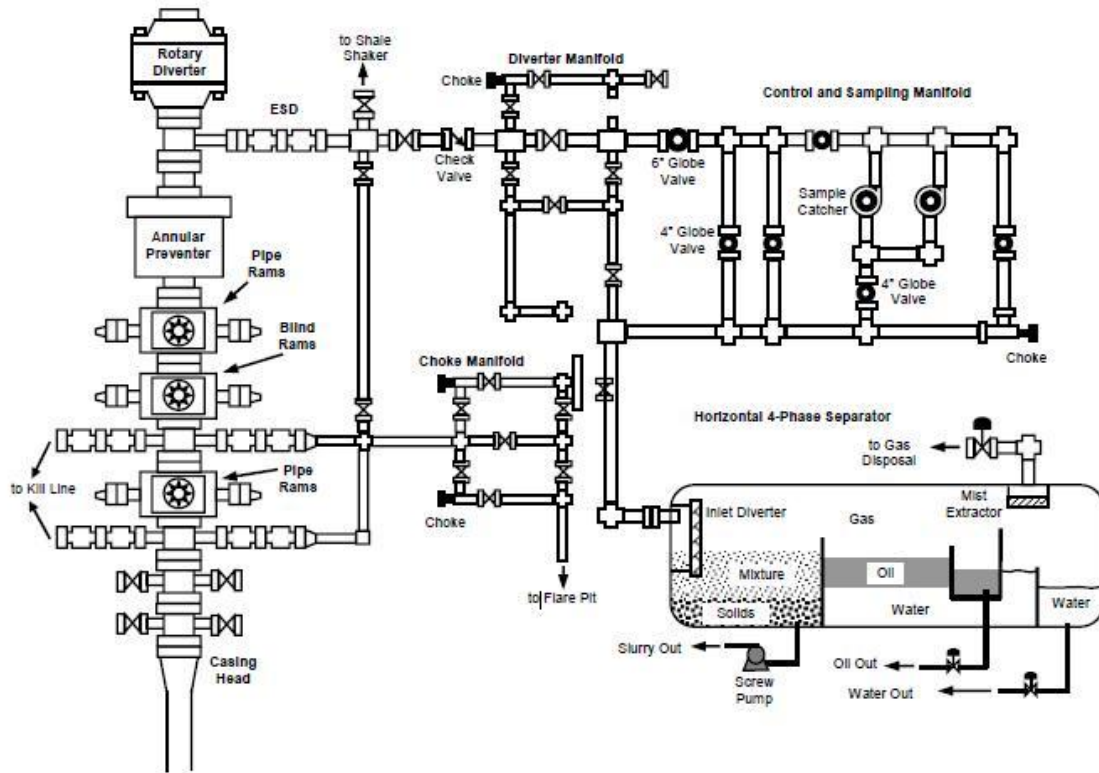

Figure 2.2 Surface equipment (Saponja, 1998)

2.4.2. Choke system

As seen on **Figure 2.2** there are two choke manifolds in a regular underbalanced drilling equipment setup. The first one is the rig choke manifold that is tied to the rig blow out preventer (BOP). This manifold is not in use unless a well control situation occurs and the BOP needs to be closed. The well pressure can then be bled off through the rig manifold. The other choke manifold is the one that is tied to the exit of the well. Here you have two chokes in parallel in a manifold so that you can operate one choke and have the other one as standby. When you need to do maintenance on one of them you can simply switch to the other one. It is also possible to operate with two chokes if high flow rates are experienced. Often there is a cross-over between the UBD manifold and the rig manifold. By doing so, you add operational flexibility and redundancies to your system. The choke is built to withstand high stresses, i.e. high flow rates and particles that are flowing out of the well. An example of the structure of a choke valve is the plug and seat design that is shown in **Figure 2.3**.

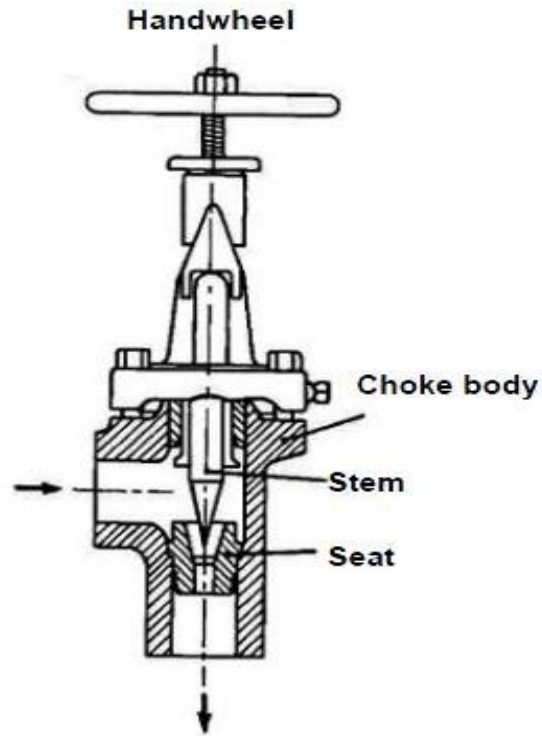

Figure 2.3 Choke design (Eck-Olsen, 2003)

The task of the UBD choke is to control the pressure in the well. By opening and closing it you can manipulate the pressure in the annulus so that you get the desired bottom hole pressure (BHP). The choke opening is based on the back pressure value you need to obtain the desired BHP.

2.4.3. Separator system

The return fluid from the well during underbalanced drilling is composed of four phases. Those phases are gas coming from injection or the formation, light liquid like oil and condensate, heavy liquid containing mud and water and solid drill cuttings. These phases need to be separated, and to do that you need a 4-phase separator. The hydrocarbon gas needs to be separated and either sent for flaring/venting or, if possible, be compressed and injected into nearby production facilities. Liquid hydrocarbons can after separation either be treated and evacuated from the rig or injected into a nearby production facility like the gas. The mud needs to be cleaned and conditioned before being pumped back into well for a new round. If there is water separated from the heavy liquid phase this must be cleaned and disposed. The cuttings must be separated and either injected back into the formation or evacuated from the rig for cleaning and disposal.

Figure 2.4 shows a 4-phase separator.

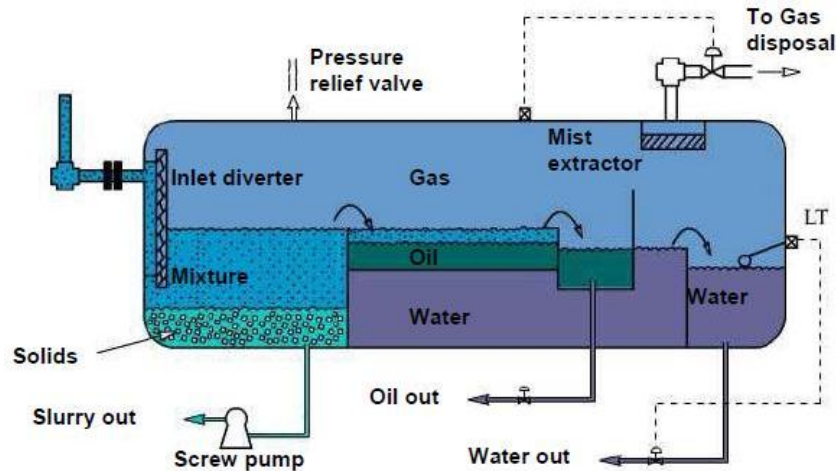

Figure 2.4 4-phase separator (Eck-Olsen, 2003)

Sometimes a two-stage separation may be required. This is normally when drilling in high pressure formations with a high rate of circulation. A two-stage separation enhances the separation of gas and liquid hydrocarbon from the drilling fluid mixture. The first stage separator operates at a higher pressure than the second stage.

2.4.4. Rotating control device

When you drill underbalanced the wellbore, including the top of the well (wellhead), is continuously pressurized. Therefore you need a sealing device that you can inject drill pipe through, and that can rotate while drilling. The rotating control device (RCD) solves this problem. It is placed on top of the well and takes over the mud's job as primary barrier in underbalanced drilling. The RCD is basically the same as the annular BOP, a rubber element that is closing around the drill pipe, except that the element is installed on bearings that allow rotation relative to the RCD housing while drilling. You have two types of RCD. The first one is a passive seal where the well pressure energizes the sealing rubber element. This is also called a Rotating control head. The other one is often called a Rotating BOP and is an active seal where the rubber element is activated by hydraulic pressure. There are large friction forces between the pipes and the rubber elements. This leads to large axial loads on the RCD, both upwards and downwards, which the RCD must be designed to manage. The friction can also be enough to rotate the RCD, if not extra force from the rig rotating system must be applied. **Figure 2.5** shows a picture of a rotating BOP.



Figure 2.5 RTI RBOP (Eck-Olsen, 2010)

2.4.5. Mud – gas injection systems

If you have come to the conclusion that you need to add gas to your drilling fluid to achieve the desired bottom hole pressure, there are three methods to choose between.

- Gas injection through the drill pipe. Gas and liquid are mixed at the top of the string and then pumped down.
- Gas injection through a parasite string. Then the gas is injected through a string that is parallel to the wellbore, and into the annulus through the casing wall.
- Gas injection through a concentric casing. The gas is injected through a micro annulus between a casing string and for example a tie back string, and injected into the annulus of the borehole through holes at the casing shoe.

There are pros and cons with all of these methods, and each of them are applicable in different drilling environments.

2.4.5.1. Gas injection through drill pipe:

The main advantage with this injection method is that you are able to achieve very low bottom hole pressures. The reason for that, compared to the other injection methods, is that you have gas all the way through your fluid column, and not just in the upper part. Since it is gas in the entire annulus you get turbulent flow all the way, and thus better hole cleaning. A lower gas rate is required, compared to a parasite string or casing, to achieve a given bottom hole pressure since the gas is injected into the annulus at the bottom of the well. (Lyons, et. al., 2009)

There are also some disadvantages with this method. The main one is that since the gas injection is ceased during connections it is difficult to maintain underbalanced conditions in the well at all times. Also the pressure needs to be bled off at connections and trips since gas is trapped under pressure between the string floats. This takes extra time compared with normal

tripping/connections. (Lyons, et.al., 2009) Since you have a compressible fluid in your drill-string the use of conventional MWD is difficult. More complex procedures regarding for example connections and tripping makes additional training of the crew necessary.

2.4.5.2. Gas injection through a parasite string:

With a parasite string you can maintain continuous gas injection during connections and tripping. You also let the well flow while making the connection. This combination makes sure the well is maintained underbalanced the whole time when you make a connection. Since only incompressible liquid is pumped down the drill-string a conventional MWD tool may be used. Also the gas injection pressure required is lower compared with the drill pipe injection method.

The disadvantages with this method are tied up to the practical modifications that need to be done. The system cannot be used in an exciting well. So if you are drilling a sidetrack this method is ruled out. You will need to modify the wellhead to get the string into the hole, and the injection point may become a weak point in the casing and reduce the well's integrity.

2.4.5.3. Gas injection through a concentric casing:

The major benefit with this method is the same as the parasite string, keeping the bottom hole pressure stable during connections and trips. Tripping and connections can be performed conventionally since you only have liquid mud in the drill string. The time to bleed of the pressure is then considerably reduced compared with the drill pipe injection method. You can also use conventional MWD tools since only liquid is pumped down the drill-string.

There are also some disadvantages that can be significant if they are not dealt with properly. The circulation system can be rather unstable if you don't make sure you are in a flow regime where slugging will not occur. The most important factor is the gas to liquid ratio (GLR), i.e. the ratio between the injected gas and the injected liquid. If it is too low well slugging will most likely be the result. (Mykytiw et.al., 2003) Other disadvantages with this method are that you may require modifications in the wellhead and/or changes in the casing program. Also it can get problematic to maintain underbalanced conditions at the bit as the hole gets longer and you get further away from the fixed injection point.

When you are choosing injection method you must look at the pros and cons for each method and how your well configuration is. As mentioned above, if the well is a sidetrack of an old well the two latter methods are normally very difficult. **Figure 2.6** shows the principle of the three methods.

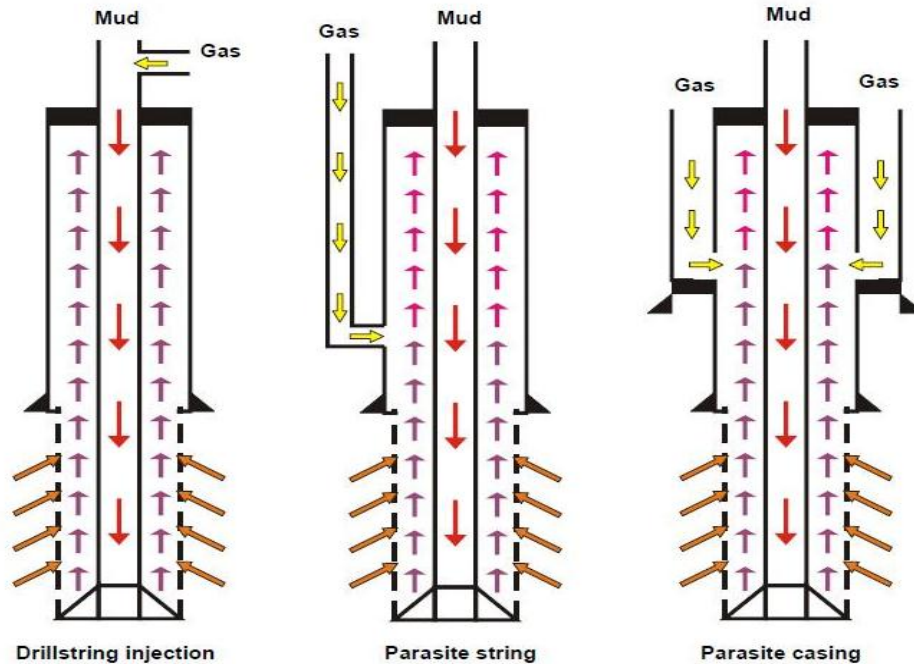

Figure 2.6 Gas injection methods (Eck-Olsen, 2003)

2.5. Planning and modeling of a UBD operation

2.5.1. Bottom hole pressure

The bottom hole pressure (BHP) needs to be controlled in underbalanced drilling. To do this, proper planning must be executed. Normally this is done by defining an operating area for the BHP. When you do that there are several aspects that need to be taken into consideration. The most important one is of course the hydrostatic pressure that is needed to get the well in sufficient under-balance. But also things like hole cleaning, borehole stability, gas injection rate and several others need to be looked into.

2.5.2. Pressure differential

When you start to plan the BHP operating area the first thing you must consider is the pressure needed to be in sufficient under-balance. The differential pressure between the wellbore and the formation must be high enough to counter the capillary pressure force that is trying to cause imbibition of fluids from the wellbore into the formation. However, the differential can't be so low that the wellbore pressure gets below the formation collapse pressure, or that the separator equipment at the surface is not able to handle the influx of formation fluids. (Guo and Liu, 2011)

2.5.3. Drilling fluids

When you have determined a suitable BHP you must decide how you are going to achieve this pressure in your well. Can you manage with just a light liquid as drilling fluid, or do you need to

mix gas and liquid to get a low enough pressure. There are also some other combinations that are normal in underbalanced drilling. Below the combinations normally used in underbalanced drilling is mentioned. (Eck-Olsen,2003)

2.5.3.1. Liquid mud (no gas added)

This is used when the formation pressure is quite high and a liquid have low enough density to provide underbalanced conditions. This is a mud that is similar to the mud used in conventional drilling operations, only lighter.

2.5.3.2. Mixture of liquid and gas

Gas is mixed into a liquid mud that can be either oil or water based, to lower the density of the fluid. The gas used can be nitrogen, natural gas, air, or exhaust gas.

2.5.3.3. Stable foam

Foam consists of gas, liquid and an emulsifier. The gas content is very high, typically between 55% and 97%, and the most common gas used is nitrogen.

2.5.3.4. Gas with liquid mist (wet gas)

To get a mist you inject small amounts of liquid into a stream of gas. The liquid is added to provide better hole cleaning around the bit.

2.5.3.5. Dry gas, dry air

Pure gas is used when you need to achieve particularly low pressures to be in under-balance. The gas used is the same as when mixed with liquid, nitrogen, natural gas, air, or exhaust gas.

An important issue when you choose the liquid phase of your drilling fluid is that it needs to be separable from the formation fluid that is produced. If not you won't be able to run your drilling fluid back into the well because it is contaminated with formation fluid.

2.5.4. Bottom hole pressure operating area

To find the correct gas and liquid injection rate (if you are injecting gas) it is normal to construct a plot similar to the one showed in **Figure 2.7**. Here you see a plot of BHP rate versus gas injection rate with lines indicating different liquid injection rates. The pressures marked on the figure is the estimated formation pressure and the collapse pressure of the formation which is the lowest allowable BHP. The lowest allowable gas injection rate is marked by the black “dash, dot, dot” line on the figure. This is the lowest gas rate that can cause sufficient velocity of the drilling fluid in the annulus. If the velocity is too low there will not be turbulent flow in the annulus and hole cleaning will thus be reduced. The upper border for gas rate is the highest gas rate the down hole motor (if used) can take before the efficiency of the motor is significantly reduced. (Saponja, 1998) We see that we have an upper and lower border for the down-hole motor which means that the rates you choose should lie between these two lines. This figure is developed by the use of the Steadyflodrill simulator which is a steady-state multiphase flow model. In addition to a steady-state model a dynamic model can be used to get a better understanding of situations like doing connections or drilling into a high productive fracture. In a dynamic model you can vary the

parameters with time so that you can see changes done to the fluid system and compare them with the situation before the change. It can give you a good impression of how your system is going to behave and is often used for training of the crew before an underbalanced operation. (Graham, 2011) The main focus in this report is on the use of a dynamic simulator so the use of a program like this will become quite clear later in this report.

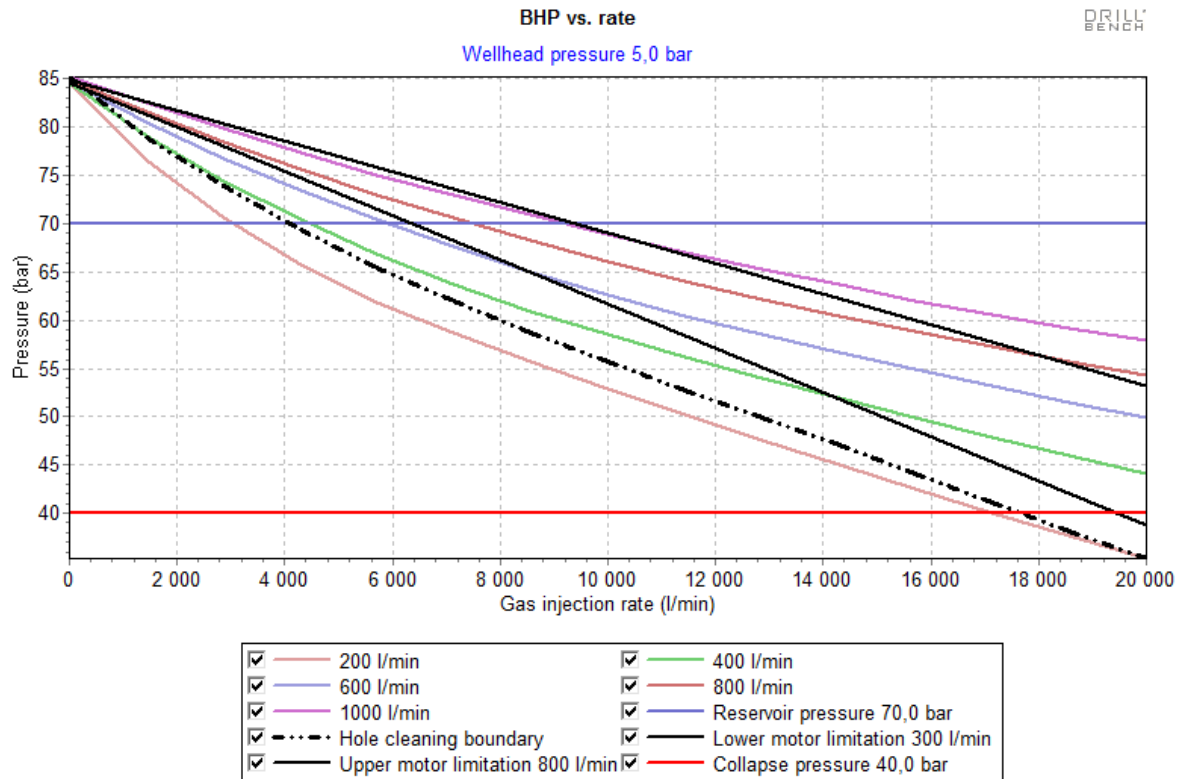

Figure 2.7 UBD operating envelope

3. Bottom hole pressure control

The ability to control and monitor the bottom hole pressure (BHP) is crucial during an underbalanced drilling operation. If you can't manage this, you may eliminate all the benefits with the underbalanced operation. It is very important not to let the pressure in the well exceed the formation pressure at any time. As mentioned in the introduction chapter, an overbalanced situation when drilling with a mud designed for underbalanced drilling may cause much more damage to the formation than if you had been drilling conventionally. It is especially important to monitor and adjust the pressure during transient conditions like connections and tripping. There are several ways to control and manipulate the well pressure in underbalanced drilling and these methods must be applied at the right time and situation.

3.1. Adjustment of the bottom hole pressure

The BHP can be described by the formula:

$$P_{BHP} = P_{mud} + P_{friction} + P_{choke} + P_{acceleration} \quad (3.1)$$

The terms in the equation are the hydrostatic pressure of the drilling mud, the friction between the fluid and the borehole wall, the backpressure on top of the well applied by the choke and the pressure due to the acceleration of the fluid. The friction pressure is connected to several factors in the drilling process. The most important factor is probably the flow rate of liquid and gas, but also factors like rotation of the drill string, rate of penetration and hole cleaning play a part. The friction pressure increases with increased flow rate of gas and liquid which is illustrated in **Figure 3.1** which shows the annular pressure loss for different flow rates of liquid plotted against gas injection rate. This plot is made by using the Steadyflodrill program package in Drillbench for one of the wells used in the case studies.

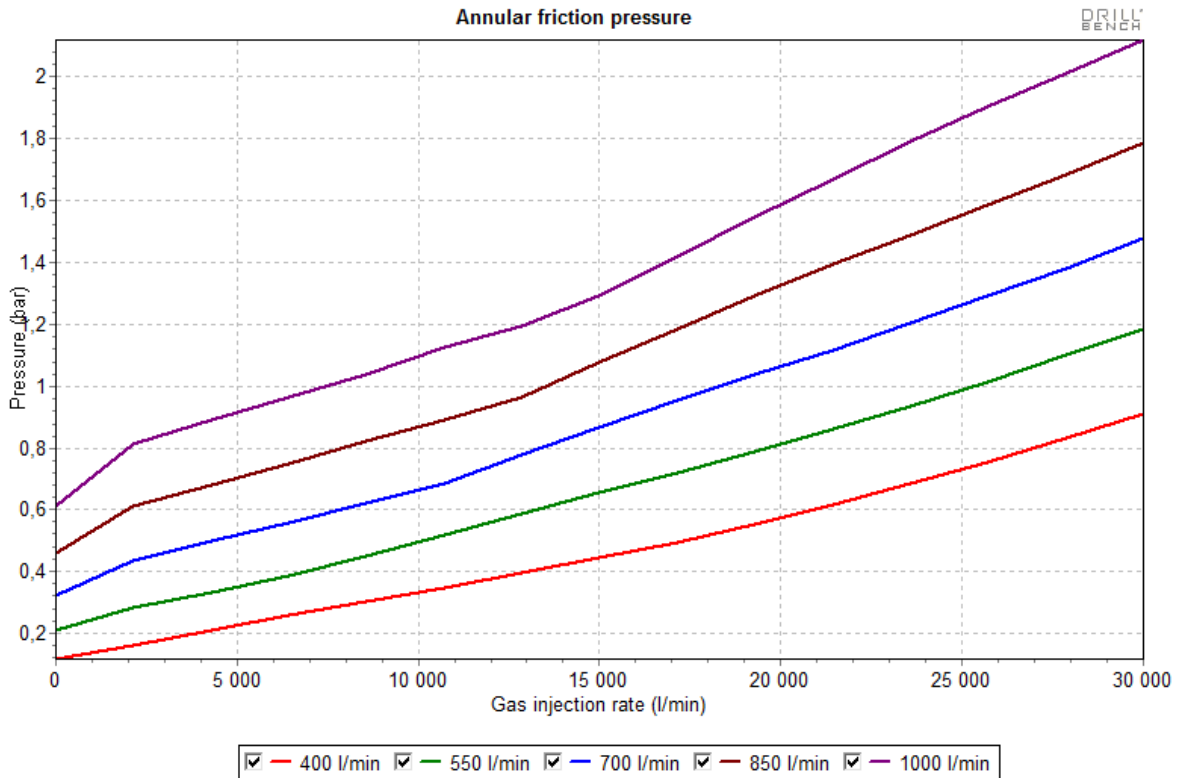

Figure 3.1 Annular friction pressure

We see that the friction pressure increases with both increased gas and increased liquid rate. In conventional drilling the way to adjust the bottom hole pressure is to change the hydrostatic pressure applied by the mud by changing the density, or change both the hydrostatic and friction pressure by changing the pump rate. Changing the density take quite some time compared to the methods used in underbalanced drilling. When you wish to change the BHP in underbalanced drilling you can to choose between three of the above mentioned pressure terms in equation (3.1) instead of just two. You can change the hydrostatic and friction pressure or the choke pressure, i.e. the back pressure. To adjust the back pressure you change the choke opening and by that reduce the flow of fluids leaving the well, and to change the friction pressure you can adjust either the liquid or gas injection rate. Adjusting the rates also changes the hydrostatic pressure in the well since more or less fluids will enter the well. To determine the choke opening or the change in flow rate you need a model of the hydraulics in the well.

3.1.1. The hydraulic model

This is a computer program which models the multiphase flow in the well, and by that is able to calculate the resulting BHP from a given back pressure. You can also change other parameters like the gas or liquid injection rate and see how the BHP reacts. To update, or fine tune, this model a pressure while drilling (PWD) tool is placed in the bottom hole assembly (BHA). The PWD tool measures the annulus pressure at the bottom of the well and sends it back to the surface. The pressure value is used to calibrate the hydraulic model to match the given

parameters like for example flow rate in/out of the well, temperature in/out of the well or the composition of the drilling fluid. (Graham, 2011) If the PWD tool fails, which is not uncommon during an underbalanced operation, the drilling can continue based on the hydraulic model since it has been adapted to the conditions in the best possible way. The model can also be used to check “what if” scenarios. For instance you can check in beforehand if it is possible to continue the operation if you have to change the gas/liquid composition because of supply problems due to the weather conditions.

3.1.2. Adjustment of BHP with the choke

The choke is the most used tool to adjust the bottom hole pressure. By regulating the choke you change the term named P_{choke} in equation (3.1). The design and structure of the choke is described in the chapter 2.4 about equipment used in underbalanced drilling. As we can read there the choke is a valve that controls the flow that is coming from the well, and by that also the pressure. The pressure that should be applied on the well by the choke to obtain a desired BHP, the back pressure, is calculated by the hydraulic model that is described in a separate paragraph. Adjusting the choke is normally considered the fastest way to change the bottom hole pressure. Measured field data provided by (Pèrez-Tèllez et. al., 2004) from two Mexican wells shows that if a change in the gas injection rate should occur, it would take 69 minutes before the BHP stabilized. If a change in the choke position occurred it would only take 7 minutes before the BHP was stable again. Such a big difference as described here may not always be the case, but choke adjustment is probably the fastest. A closer investigation of this issue will be performed in the chapter about case studies.

3.1.3. Adjustment of BHP with gas injection rate

As mentioned in the introduction the BHP can also be controlled by changing the gas injection rate. If you inject less gas, i.e. decreasing the gas-liquid ratio (GLR), the density of the drilling fluid will increase. This will again lead to a higher hydrostatic pressure from the fluid, and thus a higher BHP. If you increase the GLR by injecting more gas the BHP will be reduced, but this applies only up to a certain rate of injection.

Figure 3.2 shows a plot of the gas injection rate against the bottom hole pressure for a certain liquid rate. From the figure we can see that at lower injection rates the BHP is significantly reduced when the gas injection rate is increased just a little. This area of the plot is called the gravity dominated area and implies that the BHP is dominated by the hydrostatic pressure gradient. The friction pressure is not influencing the BHP significantly at these gas injection rates. When the injection rate reaches a certain point the curve starts to flatten out and the lowest possible BHP with the current liquid rate is reached. If the gas injection rate is increased beyond this point the annular friction will increase and balance the drop in hydrostatic pressure. With even further increase in the injection rate the BHP will start to increase, but the changes are not rapid like in the gravity dominated area.

This shows us that it is important to know whether you are in the gravity or friction dominated area when the UBD operation is performed. If you want to decrease the BHP by increasing the gas injection rate and the fluid system is located in the friction dominated area, you may in fact increase the BHP. To be located in the friction dominated area of the curve can help in controlling the BHP if a significant influx of formation gas is encountered. When you are in the friction dominated area an increase in gas concentration will not affect the BHP very much. The effect of the influx will be that it increases the BHP which will prevent further influx of gas. This leads to a more stable and controlled BHP (Saponja, 1998)

To summarize one can say that the BHP can be adjusted by changing the gas injection rate, but the rate of change depends on whether you are in the gravity or friction dominated area of the gas injection vs. BHP curve.

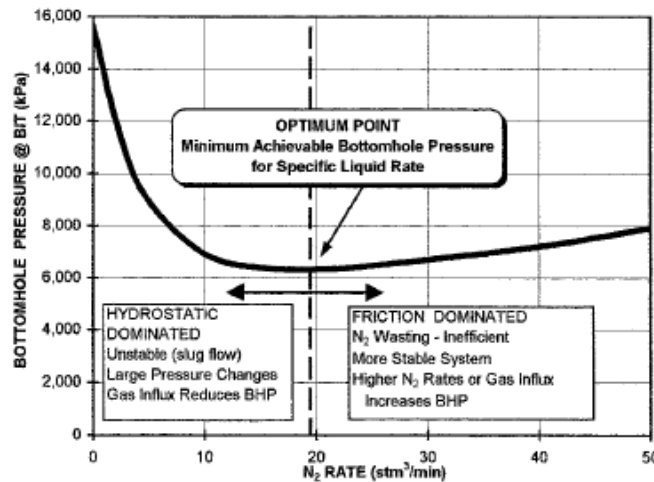

Figure 3.2 Gas injection rate vs. BHP (Saponja, 1998)

3.1.4. Adjustment of BHP with liquid injection rate

The liquid injection rate can also be used to manipulate the BHP. The principle for changing the BHP with the liquid rate is the same as for the gas rate, namely the change in density. If you increase the injection rate you will increase the density of the drilling fluid, and thus increase the hydrostatic pressure in the well. An increased rate will also make the friction pressure higher. If you decrease the rate the hydrostatic and the friction pressure will go down. The liquid rate is often increased if the pressure at the wellhead or the flow rate from the well is increasing due to a higher influx than expected from the formation. This is done to “choke” back the influx and stabilize the BHP. You cannot vary the liquid rate unlimited, factors like hole cleaning and cooling and lubricating of the bit also needs to be taken into consideration.

4. Dynaflo-drill

In this thesis I have made use of the Drillbench program package which contains several modules for simulating different parts of a drilling process. I have been using two of these modules, the Steadyflo-drill and the Dynaflo-drill. These modules simulate an underbalanced drilling process in the steady state and dynamic mode. The Dynaflo-drill has been the dominant module in my work since it describes the drilling process over time and dynamic effects like connections and tripping can be taken into consideration. The Drillbench package is delivered by the SPT group, and is based on among other things extensive research during many years performed by RF-Rogaland research. (SPT Group, 2012)

4.1. Theoretical background

If not stated otherwise the source of information used in this paragraph is the SPE paper written by (Rommetveit and Lage, 2001). The Dynaflo-drill simulator is based on the theory of conservation of mass and momentum. When using the conservation of mass theory you look at the flow of mass in and out of an element. In the Dynaflo-drill simulator the element is the wellbore and the flow of mass comes from the fluids present during an underbalanced drilling operation. It is assumed that all the variables in the equations are only dependent on one spatial coordinate, which is the length of the well, or flow path.

The following equations are the core of the Dynaflo-drill simulator:

Conservation of mass of free produced gas:

$$\frac{\partial}{\partial t} [A\alpha_{gp}\rho_{gp}] = -\frac{\partial}{\partial s} [A\alpha_{gp}v_g\rho_{gp}] - A\dot{m}_{gp} + Aq_{f_{gp}} \quad (4.1)$$

Conservation of mass of free injected gas:

$$\frac{\partial}{\partial t} [A\alpha_{gl}\rho_{gl}] = -\frac{\partial}{\partial s} [A\alpha_{gl}v_g\rho_{gl}] - A\dot{m}_{gl} + Aq_{gl} \quad (4.2)$$

Conservation of mass of mud:

$$\frac{\partial}{\partial t} [A(1-\alpha)\rho_l] = -\frac{\partial}{\partial s} [A(1-\alpha)v_l\rho_l] + A\dot{m}_g \quad (4.3)$$

Conservation of mass of dissolved gas:

$$\frac{\partial}{\partial t} [A(1-\alpha)x_{gd}\rho_l] = -\frac{\partial}{\partial s} [A(1-\alpha)x_{gd}v_l\rho_l] + A\dot{m}_g + Aq_{gd} \quad (4.4)$$

Conservation of mass of formation oil:

$$\frac{\partial}{\partial t} [A(1-\alpha)x_{fo}\rho_l] = -\frac{\partial}{\partial s} [A(1-\alpha)x_{fo}v_l\rho_l] + Aq_{fo} \quad (4.5)$$

Conservation of mass of formation water:

$$\frac{\partial}{\partial t} [A(1-\alpha)x_{fw}\rho_l] = -\frac{\partial}{\partial s} [A(1-\alpha)x_{fw}v_l\rho_l] + Aq_{fw} \quad (4.6)$$

Conservation of mass of drilled cuttings:

$$\frac{\partial}{\partial t} [A(1 - \alpha)x_c\rho_l] = -\frac{\partial}{\partial s} [A(1 - \alpha)x_c v_c \rho_l] + Aq_c \quad (4.7)$$

Pressure balance (momentum equation):

$$\frac{\partial}{\partial s} [p] = -f_1 - f_2 + [(1 - \alpha)\rho_l + \alpha\rho_g]g \cos \theta \quad (4.8)$$

Table 4.1 shows an overview of the parameters and subscripts used in the equations.

A	Cross sectional area	p	Pressure
f_1	Frictional pressure loss term	s	Distance
f_2	Localized pressure loss term	v	Velocity
\dot{m}	Gas dissolution rate	x	Mass fraction
\dot{m}_g	Total gas dissolution rate	c	Cuttings
q	Mass inflow rates	α	Gas void fraction
q_{gl}	Mass inflow rate of free lift gas	ρ	Density
q_{fgp}	Mass influx rate of free produced gas	θ	Hole inclination
f_o	Formation oil	gl	Lift gas
f_w	Formation water	gp	Produced gas
g	Gas	l	Liquid
gd	Dissolved gas		

Table 4.1 Parameters in simulator equations

To be able to solve the above equations more information from a number of sub-models needs to be acquired. These sub-models describe other processes in the fluid system mathematically.

Below the most important sub-models are listed.

- Mud density – including effects of dissolved gas, cuttings and fluids produced from the reservoir.
- Density of injected gas – both injection through drill string and/or parasitic string/annulus.
- Density of produced gas.
- Injection gas rates – both drill string and parasitic injection.
- Flow rate of fluids from the reservoir – the influx rate is calculated by appropriate reservoir models, bot matrix and fractured reservoirs can be simulated.
- Mass rate of drilled cuttings – this rate depends on wellbore diameter, density of the rock and rate of penetration.
- Rate of gas dissolution – both injected and produced gas solubility modeling.
- Mud rheology
- Friction pressure loss models – models for both single phase and multiphase flow

- Localised pressure loss models – pressure drops across an area changes along the flow path.

These sub-models are one or several algebraic equations that are based either on published work or on models developed by RF-Rogaland Research and verified through experimental studies. To solve all the equations listed above a numerical calculation method named the finite difference method is used. This is a numerical method to solve differential equations where an analytical solution method is failing. We also need input from the user of the simulator to be able to solve the equations. The different parameters that are going to be used in the operation needs to be specified by the user.

4.2. Use of the simulator

4.2.1. Basic input

When you are going to use the DynafloDrill simulator several parameters needs to be defined by the user before you can start the simulation. **Figure 4.1** shows how the openings page of the DynafloDrill simulator looks, and gives an overview of the different variables that must be taken into consideration and put into the program to get a result.

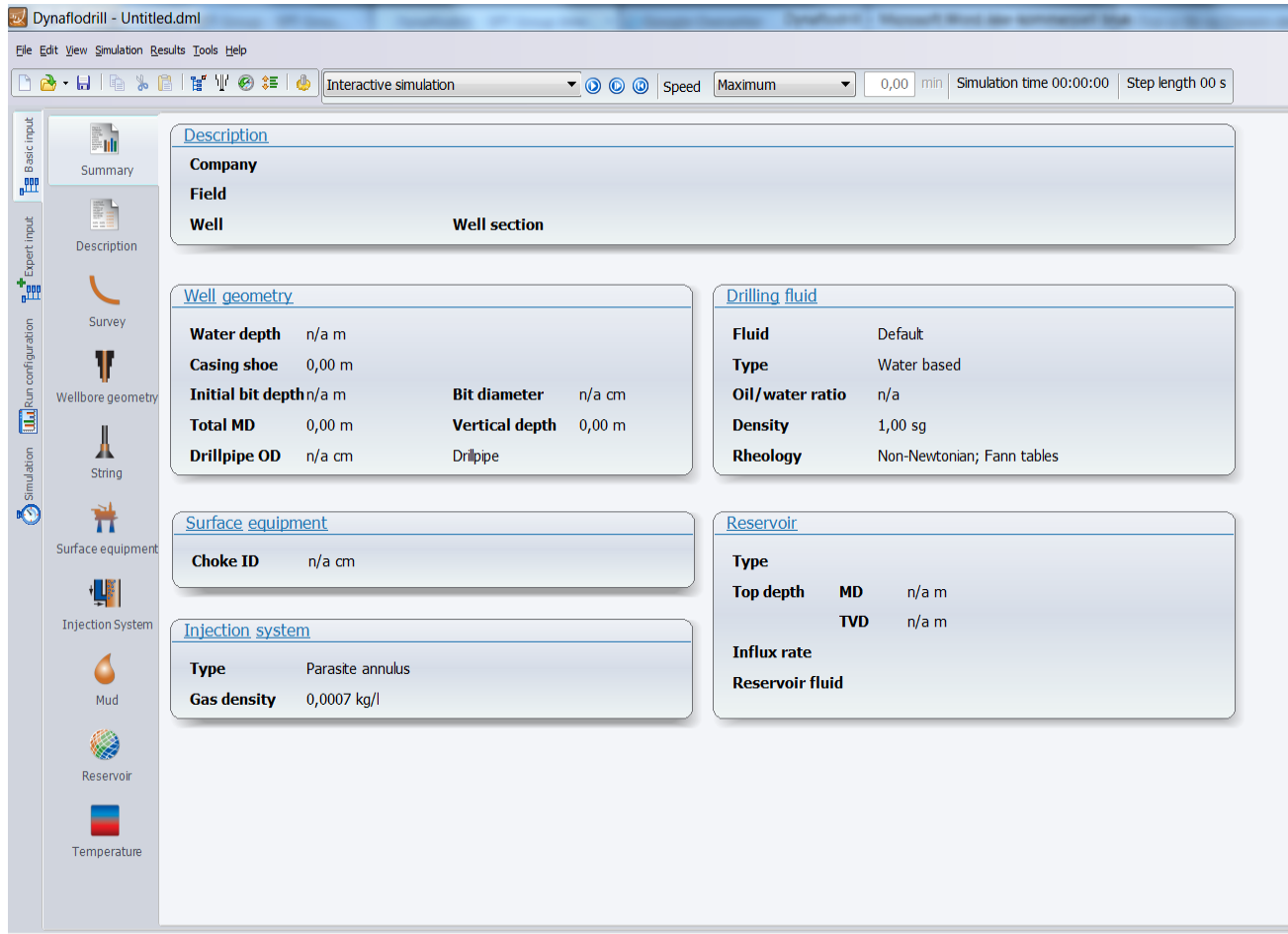

Figure 4.1 Basic input DynafloDrill

On the left side of **Figure 4.1** one sees the main categories of parameters that influence the fluid flow in the well. To get a useful result from your simulation all of these parameters must be fed with input values that you are planning to use in the actual operation.

The first category is called “Survey”. Here you enter data that describes the well path. The length, depth and inclination of the well are important factors when both the hydrostatical and frictional pressure drop, and hence BHP are to be calculated. Also the quality of the hole cleaning is dependent on the shape of the well.

“Wellbore geometry” describes the part of the casing program that is relevant for the flow in the well, i.e. the parts where drilling fluid is circulated. Here the diameters, weight pr. length of the casing and the setting depths are specified. Length and diameter of an open hole section (if any) is also specified here. The simulator offers a list of casings with specifications that are used in the industry, you can pick the casing you want to use here or enter data manually. The diameters of the casing/open hole sections decide the flow path of the circulating fluid and thus plays a part in the calculation of the pressure drop in the well.

In the “String” category the drill string features are specified. The specifications of drill pipes, drill collars and down-hole motors are entered here. Also here the simulator offers a list of different pipes that can be selected. The dimensions of the pipes contribute to the flow path of the circulating fluid, and a down-hole motor will have certain limitations with respect to flow rate and pressure which must be included in the calculations.

In the category named “Surface equipment” the inner diameter of the choke and its closing time, pump rate change of the gas and liquid pumps and the closing time of the rotating control device are specified.

Under “Injection systems” you choose whether you will inject gas through the drill string or through a parasitic string or annulus. The two gas injection methods influences the pressure in the well differently and the choice is therefore important for the calculations of both hydrostatic and frictional pressure loss. You also choose which type of gas you will inject. Several types can be used with nitrogen and hydrocarbon gas as the two most important. Also a mixture of different gases with specified percentage can be used.

“Mud” describes the mud system you are going to use. The simulator allows you to choose from several predefined mud systems, or you can insert your own values. Data about rheology models, densities of liquids and solids in the mud and whether you are using liquid or foam as a base for the mud is specified here. The properties of the drilling mud are crucial when it comes to pressure calculations. It is the most important contributor to the hydrostatic pressure in the well, and the rheology of the fluid have a significant influence on the friction pressure.

The next category is “Reservoir”. Here the formation you are planning to drill through must be described. You can choose between either a matrix or a fractured reservoir. Then you must specify the top and bottom of the reservoir, the top pressure and temperature, permeability and porosity and which type of reservoir fluid. To calculate the influx from the reservoir a certain model must be used and you can choose between a constant influx, a linear or quadratic PI model or a reservoir model which calculates the influx based on the input reservoir data. At the end the different reservoir fluids must be more closely described with densities, compressibility, volume factors etc. Also the cuttings need to be described in this section. This section is one of the most important ones to fill in since the reservoir pressure and the fluids inside it are of high importance when it comes to the design of the rest of the fluid system you need to use to obtain a successful operation.

The last category is “Temperature. Here you can specify temperature values for different depths down the well to create a plot. Both temperature in the drill string and annulus can be specified here. Temperature plays a part in the fluid behavior in the system. High temperature can lead to more free gas and more volatile liquids.

4.2.2. Expert input

The categories mentioned so far are described as the basic input. The next step is to move on to what DynafloDrill calls expert input. **Figure 4.2** shows what the expert input page looks like.

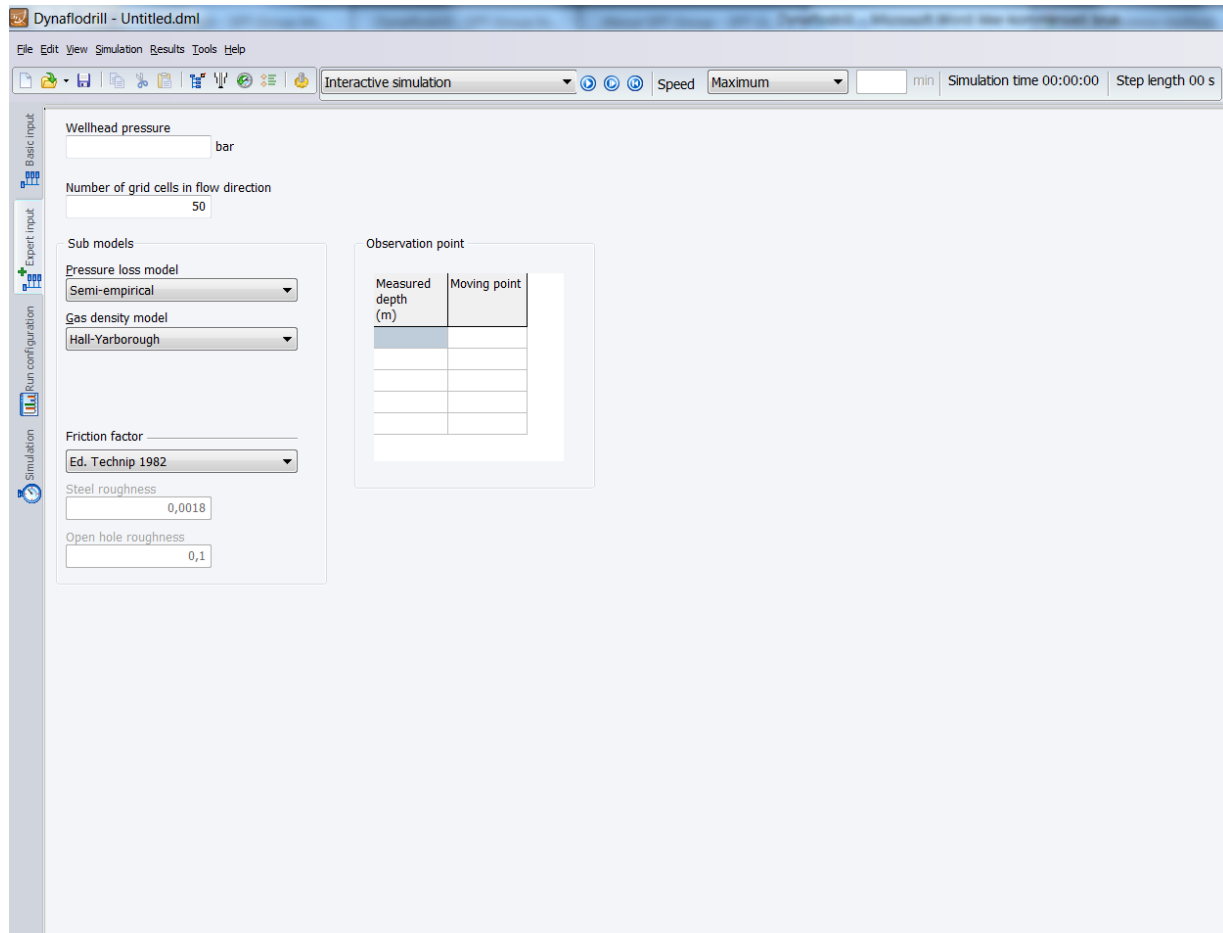

Figure 4.2 Expert input DynafloDrill

On the figure we see that we can specify the wellhead pressure, which is a constant pressure that is always applied at the top of the well even when the choke is fully open. The number of grid cells that will be used in the calculations is specified in this section. This number defines the level of detail which the drill string and annulus is discretized. The higher the grid number, the higher will the accuracy of the calculations be. The time of computation will increase linearly with the number of grid cells. (SPT Group user guide, 2011) The next you can choose is which pressure loss model and friction factor model you want to use. The choice here will affect your result and one should think through which model that fits one's situation best. We also see that we can put in observation points along the well path. This is points where the pressure can be measured and plotted during the simulation.

4.2.3. Simulation

The last window that needs to be described is the actual simulation window. This is the window that is used during the simulation and all the results are displayed here. **Figure 4.3** shows how this window looks. We see that we also need to put in some values on this page.

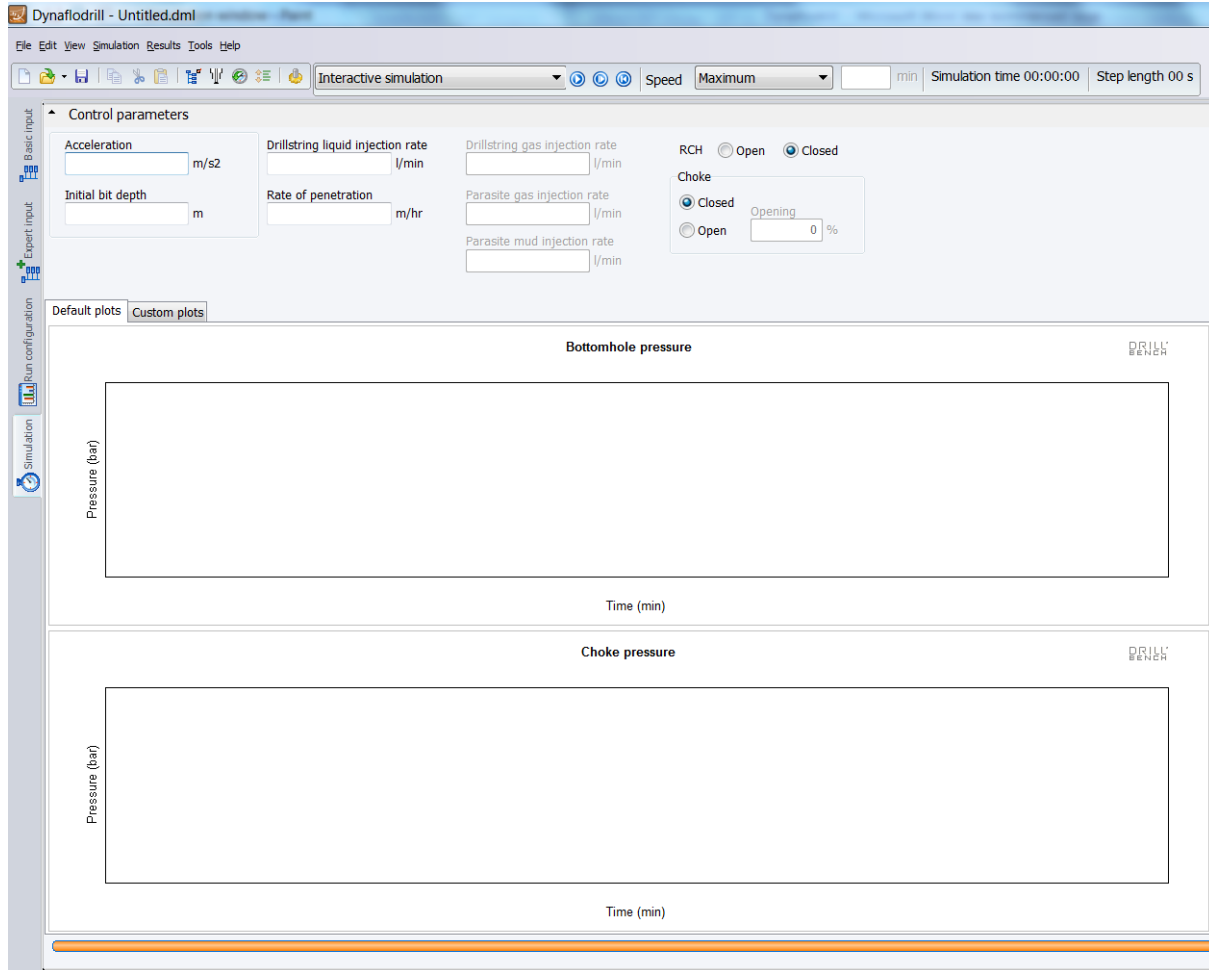

Figure 4.3 Simulation window DynafloDrill

The first parameter is the acceleration of the drill string when tripping in/out of the well, as well as the acceleration of the drilling velocity (SPT Group user guide, 2011). Then initial bit depth and rate of penetration must be decided before the most important parameters can be specified. The liquid injection rate, gas injection rate and choke opening are the most important input parameters during the operation. These are the parameters that you can change during the drilling process, and thus change the results of the simulation. Here you can also choose whether or not the RCD should be open. The simulation can be stopped and started as much as you like by using the blue on/off button seen up in the middle on **Figure 4.3**.

As I mentioned above the number of grid cells decide the computation time, but also the complexities of the calculations plays an important role here. As a measure of the computation

time the step length between each time step can be used. If the step length is big the simulation runs fast, and if it is small the simulation runs slowly. The more complex calculations the shorter the time step, this goes on until the simulator can't solve the equations anymore and the simulation stops. My experience when using Dynafldrill is that when you are simulating fluid systems with a lot of free gas, especially at the top of the well, the simulations run slowly and sometimes they are stopped because the simulator is not able to solve the equations the simulator is built on. This means that you can't always simulate exactly the way you want, but as I got more and more used to work with the simulator I did not find this issue as big a problem as I did during the first time I worked with it.

4.3. Steadyflodrill

The Steadyflodrill module in the Drillbench package is the steady-state version of the Dynafldrill module. It provides the same accuracy and quality as the Dynflodrill simulator, but it is more suited to look into several solutions and comparing these than Dynalfodrill. (SPT group, 2012) Since this is a steady- state simulator it doesn't provide data plotted against time, but it shows "snapshots" of a situation with exactly those parameters that you have given in. The basic and expert input is very similar to Dynafldrill and most of the same values must be put into Steadyflodrill as well. **Figure 4.4** shows a typical graph created with Steadyflodrill.

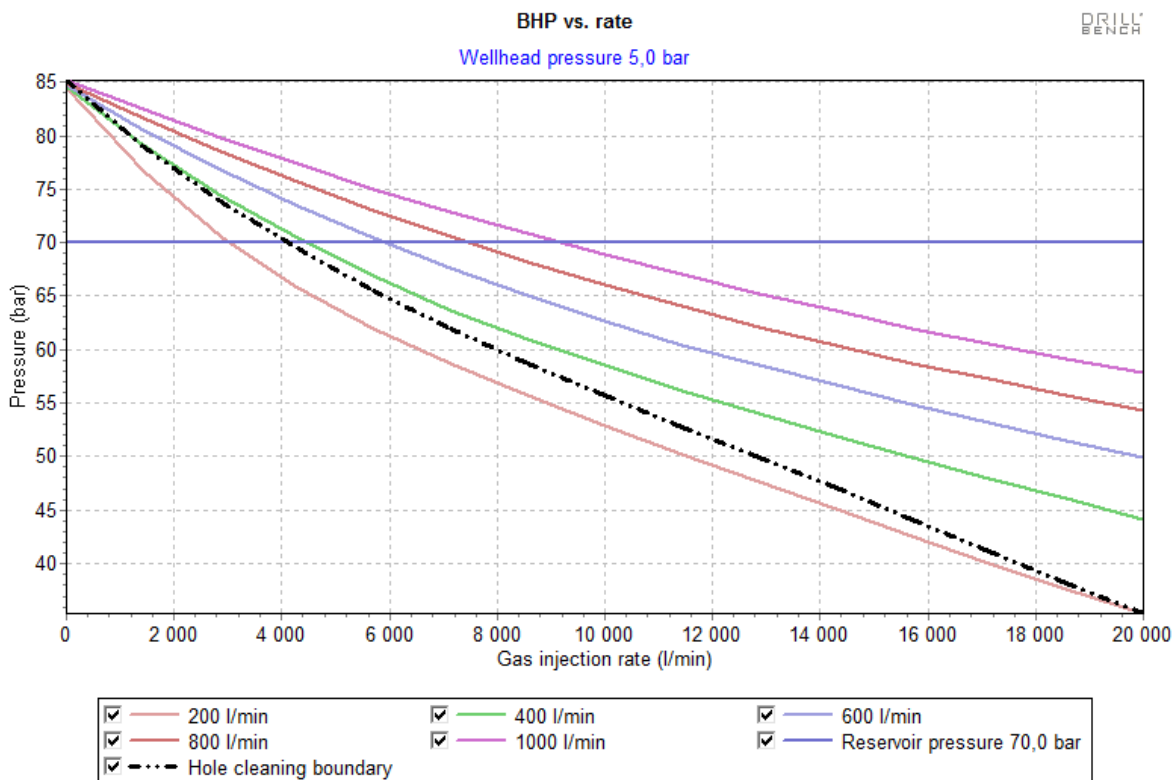

Figure 4.4 Graph Steadyflodrill

We see here BHP plotted against gas injection rate for several liquid rates. The dotted line is the hole cleaning boundary. If you select a liquid rate below this line, like 200 l/min in this plot, you

well get trouble with the hole cleaning based on the cuttings data you have given in. Creating plots like these is what I have used this model for the most. This kind of plots helps when you are to select which liquid and gas rates you are to start your drilling process with. Here you can easily compare different rates and find the one that suits best for your conditions.

5. Case studies

5.1. Drilling

In this part of the case study I will focus on the parameters used to control and adjust the BHP during the drilling operation, i.e. the liquid (mud) flow rate, the gas injection rate and the back pressure applied by the choke. Often the choke is considered to be the most effective parameter when a change in the BHP is desired. (Pèrez-Tèllez et.al, 2004) I would like to investigate this further and look into the reasons behind the BHP changes caused by the different parameters and which of the three that changes the BHP the fastest. I will also look into the phenomenon of liquid hold up and its consequences for the drilling process.

5.1.1. Under pressured well

Figure 5.2 shows a BHP curve for an under pressured well. This curve is not from an actual drilling process, but will be used to look into the response from changes in the circulating parameters. The goal in the test was to start from the parameters shown in **Table 5.1** Experiment values under pressured well

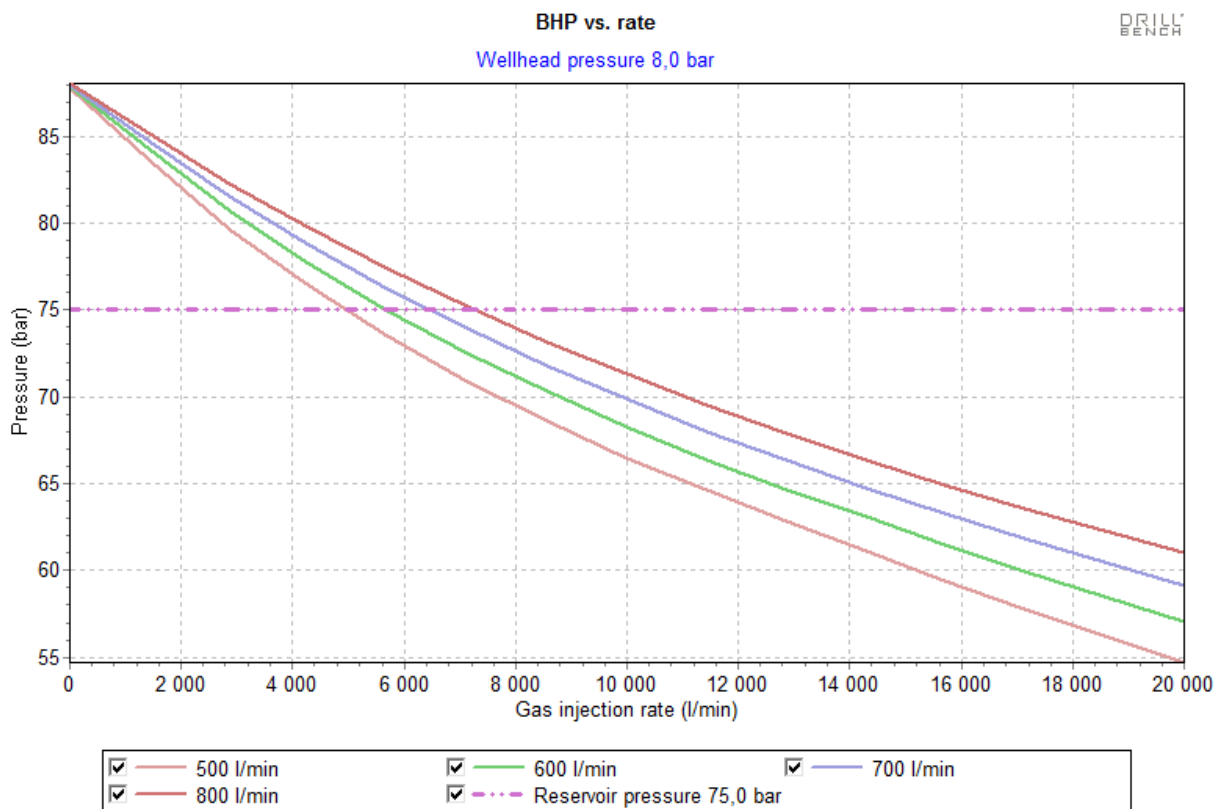

Figure 5.1 BHP vs gas injection rate

and then increase the BHP approximately 4 bar by change one parameter at the time and keeping the other ones constant. **Table 5.1** also shows the parameter values needed to increase the BHP

with 4 bar. During the testing there was some influx from the reservoir which is plotted in **Figure 5.3**. To obtain the parameter values used in the experiment I first started with the Steadyflodrill simulator and made a steady state plot of the BHP against gas injection rate like the one showed in **Figure 5.1**. By using a function in the simulator called “track values” I could see the values the graphs are made up of, and by that be able to see how much the BHP would change if I changed the gas injection rate, jumped to another liquid rate graph or if I changed the wellhead pressure. This method gave a good impression of where the values needed to lie to obtain a useful result. When I had done this I switched to the Dynaflodrill simulator and fine-tuned the values there before making the experiment plots. So all in all some trial and error had to be performed to get a useful result, but with the starting help from the Steadflodrill simulator the time spent on this was not very long.

	Start values	End values
Liquid rate	500 lpm	700 lpm
Gas rate	15000 lpm	11680 lpm
Back pressure	8 bar (100% open choke)	9,7 bar (45% open choke)

Table 5.1 Experiment values under pressured well

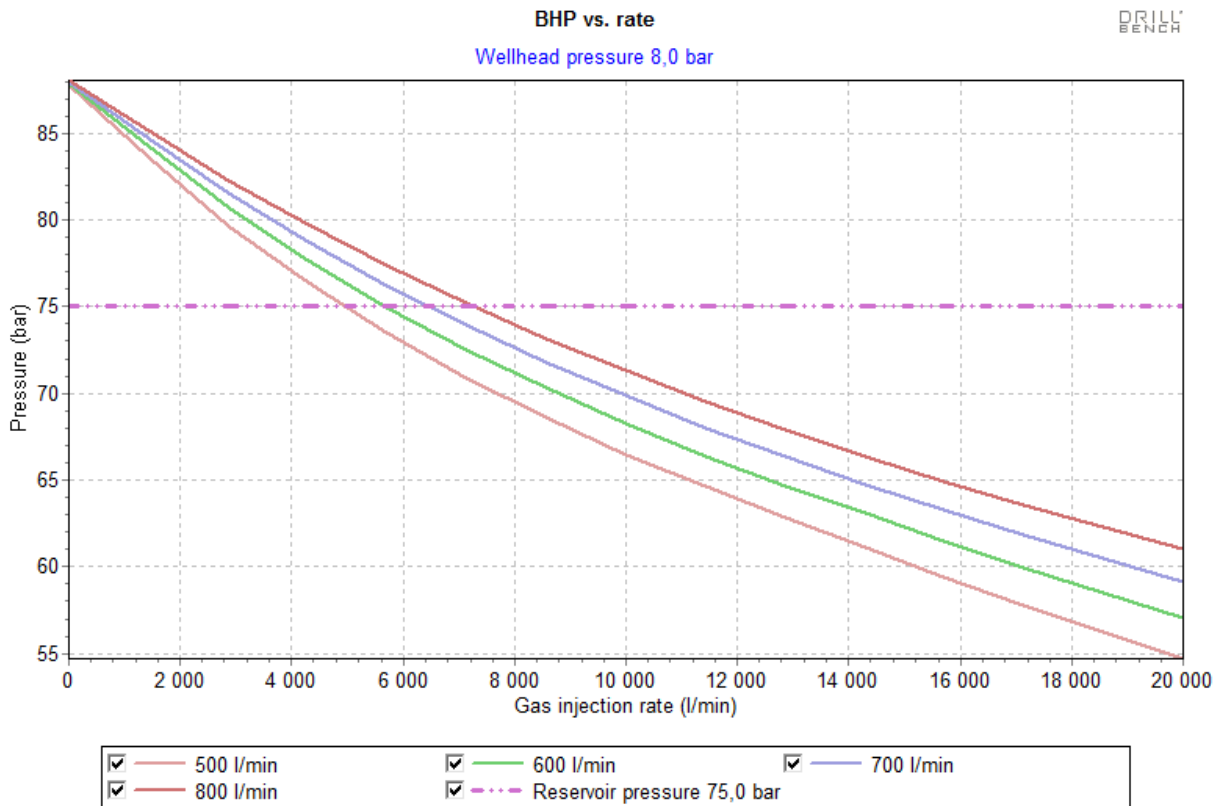

Figure 5.1 BHP vs gas injection rate

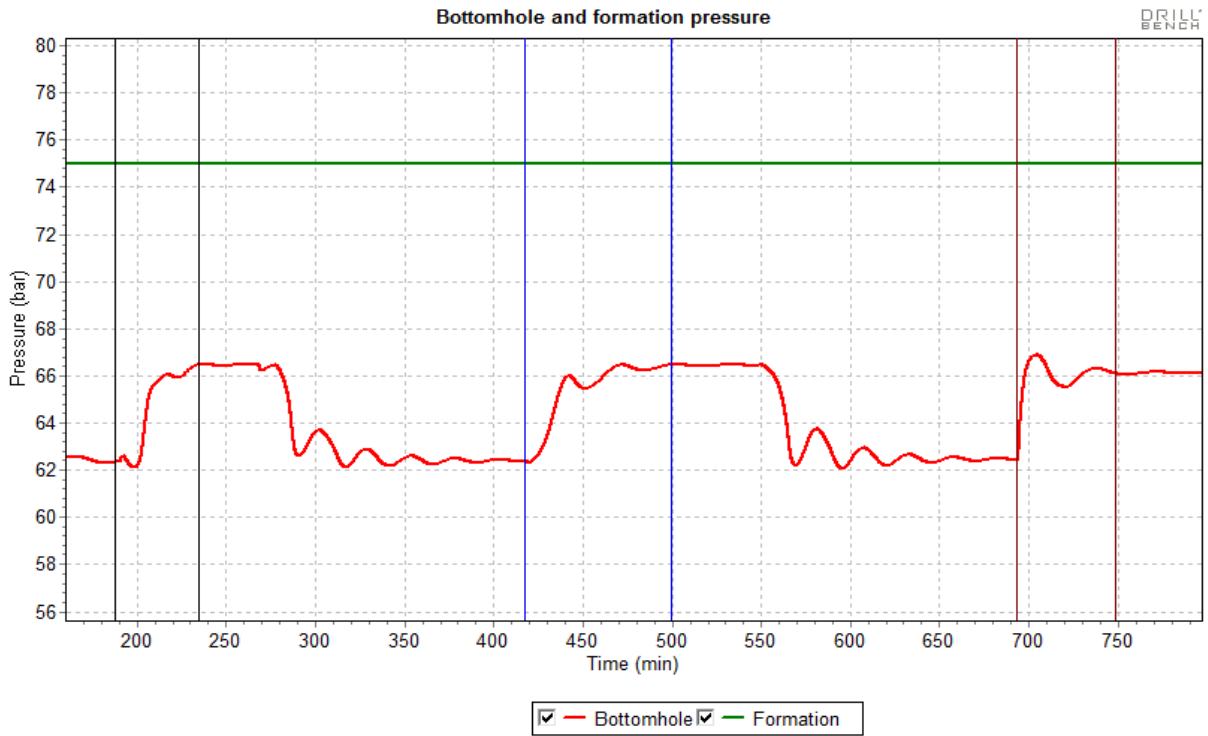

Figure 5.2 BHP under pressured well – drilling

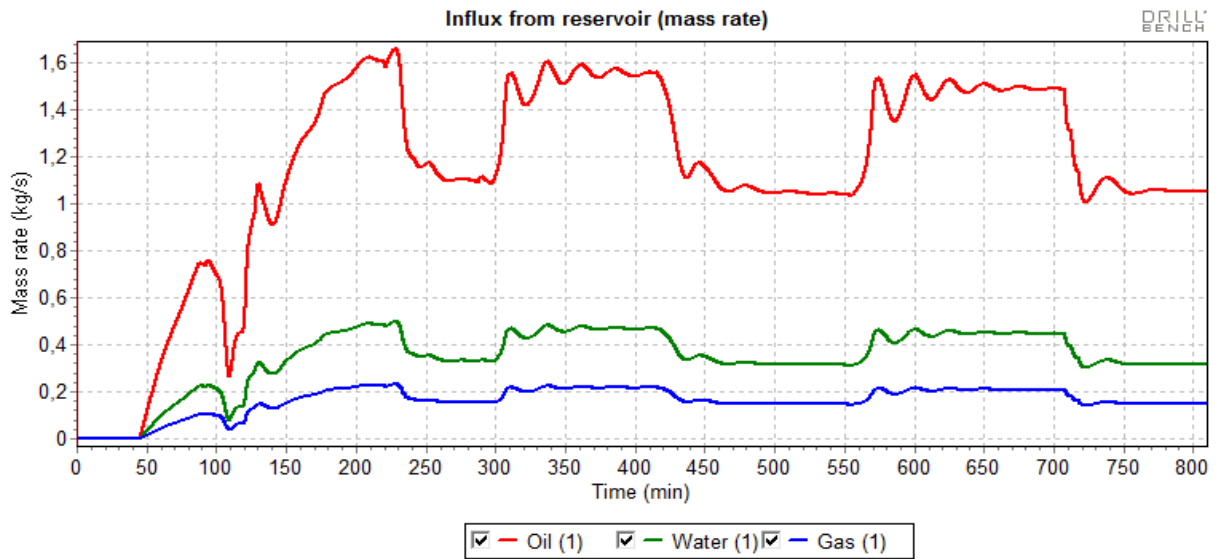

Figure 5.3 Influx under pressured well - drilling

In **Figure 5.2** we see 3 increases in BHP which comes from the changes in parameters. The first one (from the left) is the change in liquid rate, the next the gas rate and the last one from the change in choke position. We also see that the BHP returns to its original level after each increase since I then changed the parameters back to their original values before I tested the next

parameter. The same trend can easily be observed on **Figure 5.3** where it is seen as a drop in the influx when the BHP is increased. When the test was performed I waited for the pressure to stabilize at around 62,5 bar, then I changed the parameter to the new value and then waited for the BHP to stabilize at a new level, which then would be around 66,5 bar if everything was done correct. The bars on **Figure 5.2** mark where the change in parameter was performed, and when a reasonably steady – state situation was obtained.

5.1.1.1. Liquid rate

If we start with the change in liquid rate we see that this is actually the first parameter to obtain a stable BHP after the change. If we look at the curve we see that the BHP first goes a little bit up due to the increase in friction pressure caused by the increased flow rate. This alternation can also be seen in the plot of liquid flow rate in and out of the well which is shown in **Figure 5.4**.

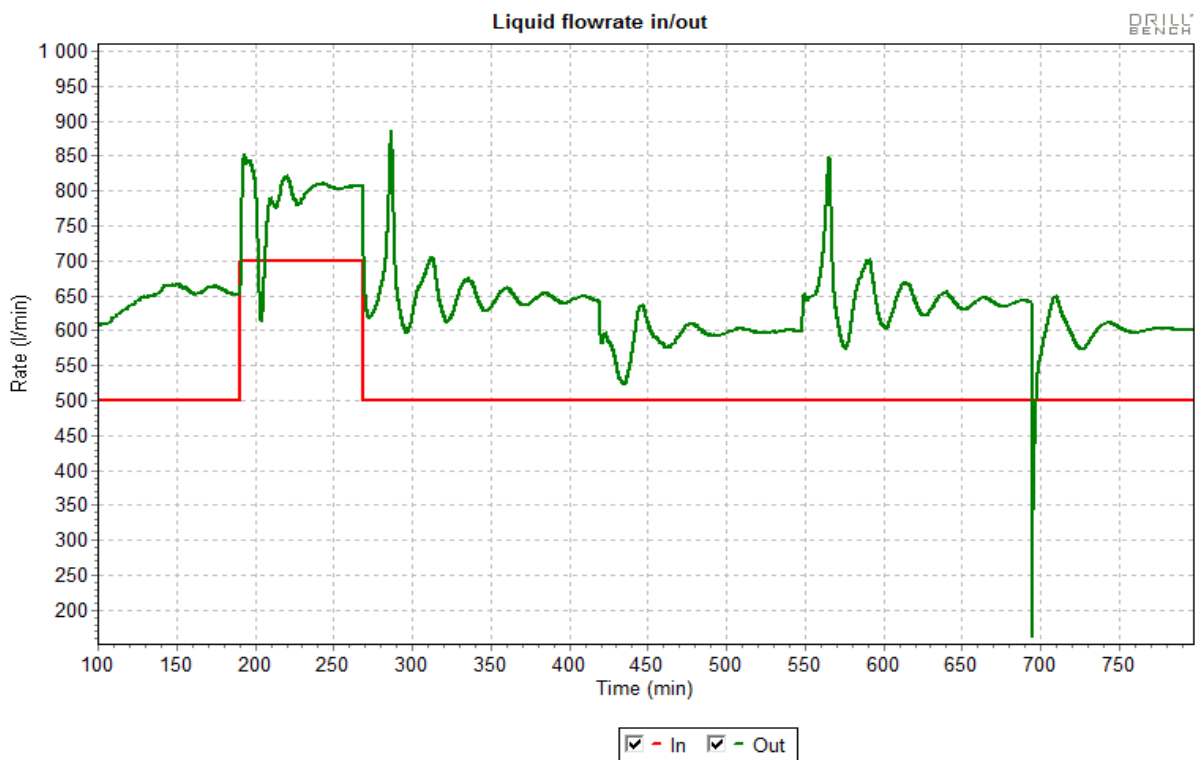

Figure 5.4 Liquid rate in/out under pressured well - drilling

Here we see that the flow rate of liquids from the well is alternating when the flow rate in is increased. The reason for this alternation in both BHP and flow rate from the well is probably that we are dealing with a multiphase flow regime. The GLR in the well doesn't change instantly to its new level at every location in the well. Some of the free gas present in the well must be circulated out to make room for the new liquid which is entering the well. This process is not a steady process and fluctuations must be expected.

5.1.1.2. Gas rate

When looking at the gas rate we see the same trend as when changing the liquid rate, some alternation in the BHP before stabilizing. The reason for this is that the two operations are basically the same: Changing the GLR to a new level. We can see on **Figure 5.2** that the BHP rises a bit slower and takes a bit longer to stabilize when changing the gas injection rate than when changing the liquid rate. The reason for this is probably that a reduction in the flow rate of fluids changes the GLR slower than an increase, which is the case with the liquid rate change.

5.1.1.3. Choke

Changing the choke opening does not change the BHP in the same way as the two previous parameters. Modifying the choke opening does not add or remove any mass to the circulating system, but changes the GLR by applying back pressure. When looking at **Figure 5.2** and in **Table 5.1** one can see that the increase in back pressure of 1,7 bar gives an increase in BHP of 4 bar. This has again to do with the fact that we are dealing with a multiphase flow system. When back pressure is applied the gas bubbles in the well get compressed. This leads to more space for the liquid phase, and the result is that more liquid is pumped into the well than what is flowing out. (Guo and Ghalambor, 2004) A bigger proportion of the borehole will then be filled with liquid, with a higher hydrostatic pressure gradient as the result. All this will lead to an extra increase in the BHP, in addition to the back pressure increase. **Figure 5.4** illustrates this by showing a spike downwards for the flow rate of liquids out of the well when the choke is being closed. The amount of free gas is highest at the top of the well and this, along with the fact that the gas is more compressible at lower pressures high up in the hole, leads to that all the “new” liquid in the column will be found here. **Figure 5.5** shows the amount of free gas in the annulus before and after the choke closing. We see that the amount of free gas at the top have changed from about 65% to about 58% after the closing. At the bottom there is almost no change at all. Before the amount was 21,8%, and after it was 21,7%. From 600 m and down the changes in amount of free gas is negligible.

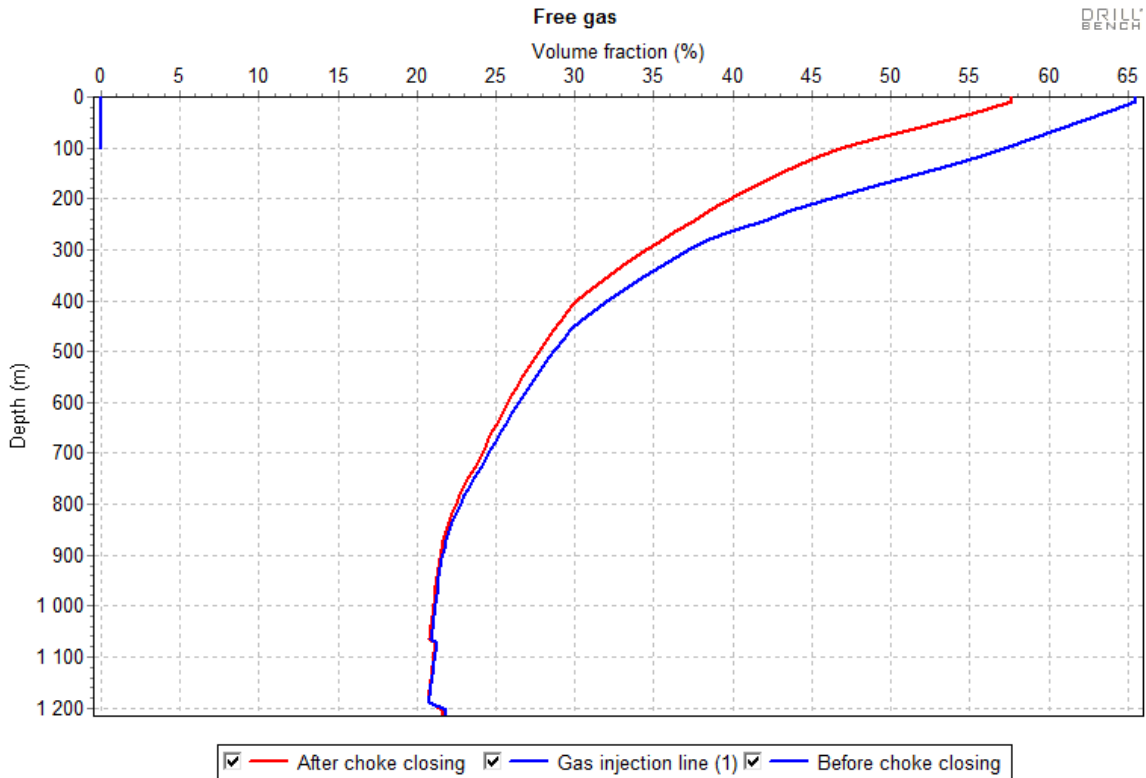

Figure 5.5 Free gas before and after choke closing under pressured well - drilling

5.1.2. Over pressured well

Over we have looked at the drilling of a well which needs gas injection to be able to achieve underbalanced conditions and to bring reservoir fluids to surface. Now we will take a look at a well with a different reservoir pressure. The well path and the fluids in the reservoir are the same as before, but the pore pressure is now higher, so no gas mixing in the drilling fluid will be necessary. **Figure 5.6** shows the BHP in the same manner as for an under pressured well. The difference here is that since we don't inject gas, no changes in the gas injection rate can be made. **Table 5.2** summarizes the parameters used in the test. To obtain the parameters I used the same method as described in the paragraph about the under pressured well, except that here I could only use a plot like the one in **Figure 5.1** when looking at BHP values when the gas injection rate where zero.

	Start values	End values
Liquid rate	500 lpm	700 lpm
Gas rate	0 lpm	0 lpm
Back pressure	8,9 bar (48% open choke)	9,9 bar (35% open choke)

Table 5.2 Experiment values over pressured well

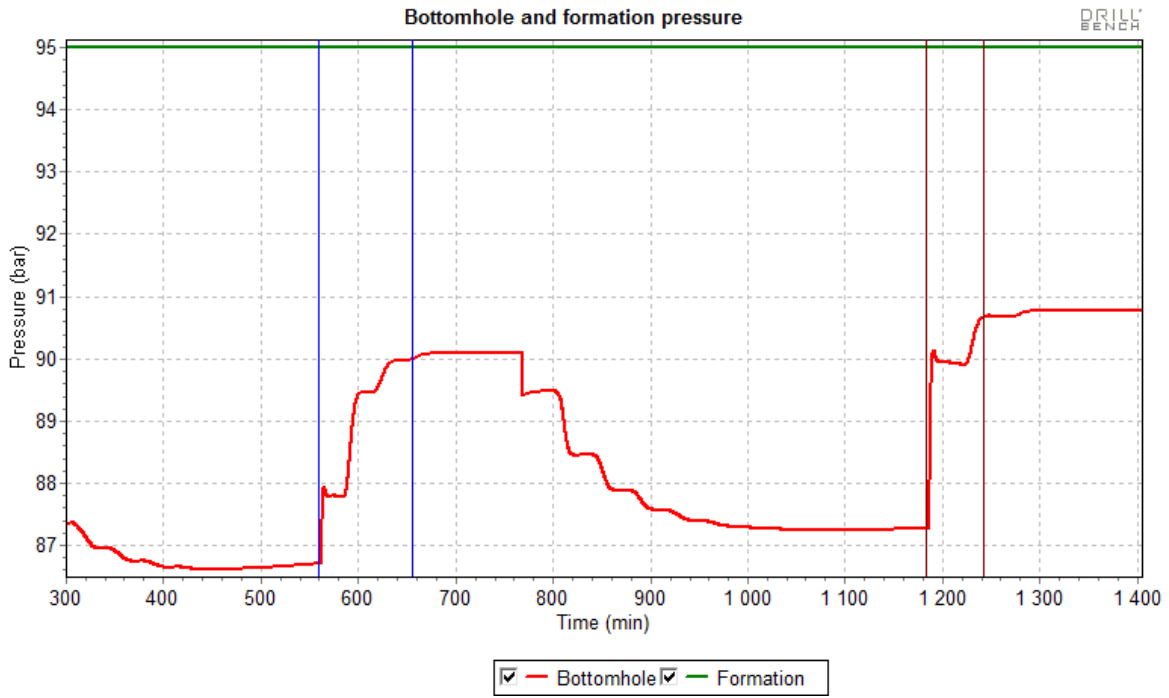

Figure 5.6 BHP over pressured well – drilling

Also here the goal of the test was to increase the BHP with approximately 4 bar. The influx of formation fluids is shown in **Figure 5.7**. The influx is not exactly the same, but it is in the same area as before. It is difficult to compare the two situations at a very detailed level since it is two different situations and the pressure changes will not be exactly the same. What is interesting when comparing the two BHP plots is to see if the BHP reacts differently when there is no gas injected, and less free gas in the annulus overall. It is important to notice that the reservoir produces some gas which will go out of solution when reaching the top of the well. This means that even though no gas is injected it doesn't lead to an annulus which is completely without free gas.

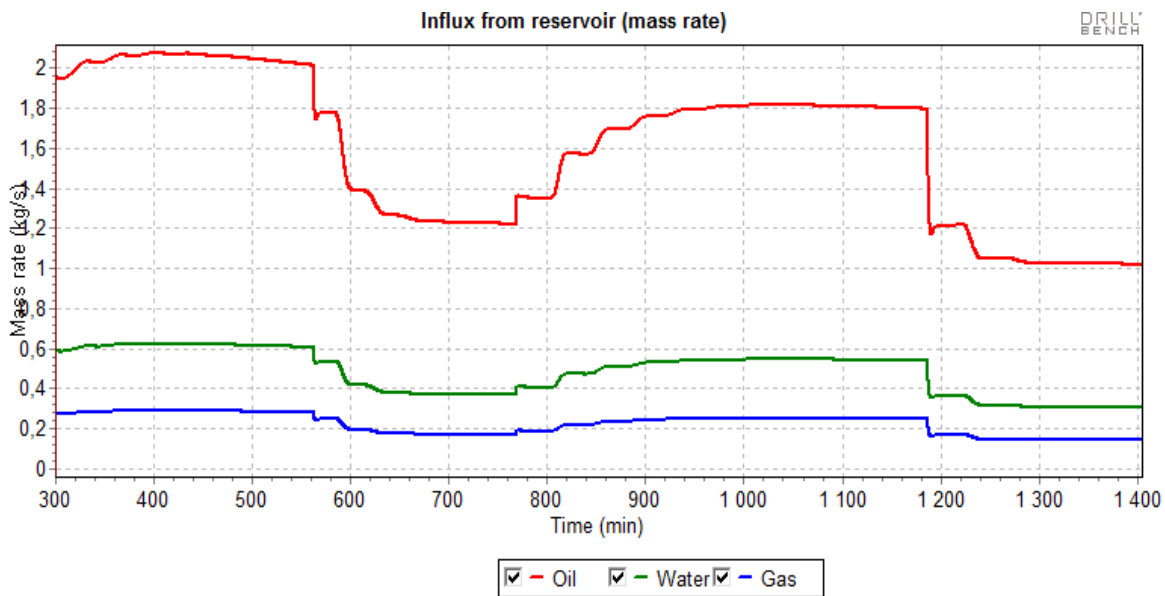

Figure 5.7 Influx over pressured well - drilling

5.1.2.1. Liquid rate

When looking at the change in liquid rate we see a quick response in the BHP when the flow rate is increased. The BHP then stabilizes for about 15 minutes before starting to rise again. This behavior is explained in the following way. The first BHP increase comes from the increase in frictional pressure caused by the increase in pump rate. The second increase starts when the GLR starts to change and thus also the density of the fluid in the annulus starts to change. When the GLR has reached a new and stable level the BHP will stop increasing. If one compare the BHP plots from the under pressured well with the over pressured, one sees that the change caused by the frictional pressure is clearer in the over pressured well plot. In the under pressured well plot the frictional and hydrostatical change in pressure glides more into each other and the difference is not as visible. The reason for this difference is probably connected to the gas amount present in the well. When the well is mostly filled with liquid, which for all practical purposes is incompressible, the increase in frictional pressure is much faster transmitted from the top to the bottom of the well.

5.1.2.2. Choke

As mentioned above we have some free gas in the annulus. This gas is only located at the top of the well. When looking at **Figure 5.6** we see an almost instantaneously increase in the BHP when the choke is being closed. This is expected since the well is almost entirely filled with liquids. When the choke is being closed less fluid are leaving the well than before. Since the flow of liquid into the well is the same, the result will be a higher pressure all along the annulus. This pressure increase will compress the gas and the same effect as described under choke regulations for an under pressured well will lead to a higher BHP increase than if the well was filled entirely with liquid. After the first BHP increase we see that the pressure stabilizes for some time before increasing to its final level. A reason for this can be that when the BHP is increased the influx of formation fluids goes down. This means that less gas is entering the well. By that I mean formation fluids which will become gas when it gets to the top of the well. Since the liquid injection rate is kept constant the GLR in the well will start to change. When this new composition of liquids reaches the top of the well a lower GLR will be established and the BHP will increase further. **Figure 5.8** illustrates this by showing the amount of free gas in the well in the period of stable BHP after the first increase, and the amount after the last increase in BHP.

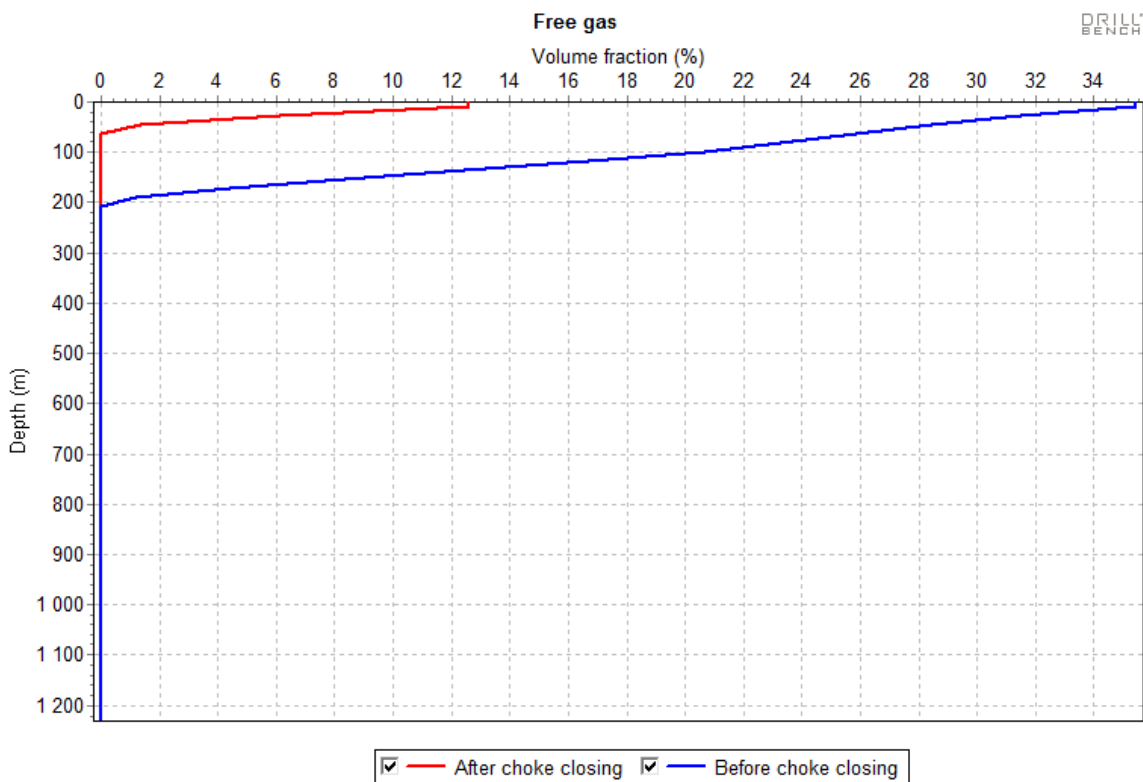

Figure 5.8 Free gas before and after choke closing over pressured well - drilling

5.1.3. Conclusion

This test has shown us that the choke is not always the fastest way to change the BHP. We have seen that the liquid rate parameter actually changes the BHP the fastest for the under pressured

well. The reason for this is probably that the well drilled is a relatively short one, and that it therefore don't take so long time to alter the GLR and thus the density of the drilling fluid to its new level. For the over pressured well the situation is opposite. In the over pressured well there are very little gas in the well compared with the under pressured one. A pressure change coming from a reduction in the choke opening will be faster transmitted through a liquid column due to its incompressibility, and thus increase the BHP faster. In the end we then see that we have two different parameters that change the BHP the fastest. The change in the choke opening is then not always the fastest way to change the BHP. Which parameter that is will vary with fluid system, well type, influx of formation fluids etc.

Knowing how to most efficiently change the BHP is important since it allows you to respond the quickest possible way to a situation. For instance if you need to change the BHP fast due to a higher influx of gas than expected it will be desirable to use the parameter with the shortest response time to stabilize the situation. Knowing how the different parameters influence the multiphase flow system is important since it can give a better understanding of why the well reacts as it does if changes in this system like a higher influx than expected should occur. Adjustment of operation parameters can then be made more correctly.

5.1.4. Liquid holdup

Liquid holdup is a phenomenon that takes place in multiphase systems because the gas and liquid phases are not flowing with the same velocity. In underbalanced drilling this is driven by the difference in density between the two phases. When gas and liquid are flowing downward through a pipe the liquid will flow faster than the gas due to its higher density. When flowing upward a pipe the gas will flow faster than the liquid resulting in what is called liquid holdup. (Lyons et. al., 2009) This will lead to a different GLR at a certain place in the annulus than at the injection point. At the top of the annulus you will have a higher GLR than at the bottom since the gas moves faster than the liquid. In other words, less liquid is coming out from the annulus than what is being pumped in through the drill pipe. This change in GLR will affect the BHP. A lower GLR at the bottom increases the hydrostatic pressure since the liquid with its higher density gets more dominant in the pressure column. This will increase the BHP from the level it would have been at if the GLR had been constant throughout the entire circulating system.

Mathematically liquid hold up can be presented as follows. (Lyons et. al., 2009)

$$\gamma_L = \frac{V_L}{V} \tag{5.1}$$

$\gamma_L =$ liquid holdup, fraction

$V_L =$ volume of liquid phase in a pipe segment

$V =$ volume of the pipe segment

Figure 5.9 illustrates the phenomenon of liquid holdup.

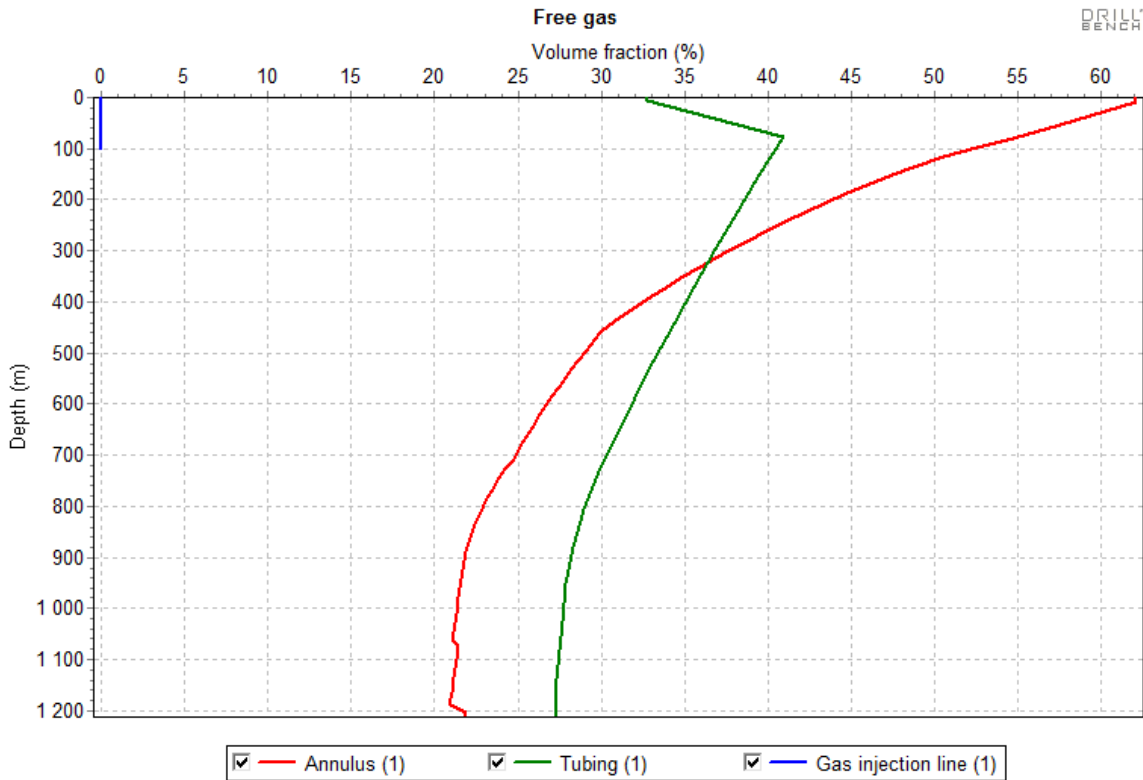

Figure 5.9 Free gas - liquid holdup

Here we see the volume fraction of free gas in the under pressured well discussed above. At the moment the plot is made, the well is being circulated with both liquid and gas injected through the drill string. The holdup effect can be observed in both the annulus and in the drill string. In the drill string the flow goes downwards which means that the liquid phase will flow fastest, which can be seen in the reduction of free gas from the top to the bottom of the string. In the annulus we see the same trend, more gas at the top and less at the bottom. We see that at the bottom of the annulus the amount of free gas is less than what it is at the top of the drill string. This means that there is a higher liquid content at the bottom of the well, which as mentioned above, will affect the BHP.

5.2. Connection

When doing a connection the goal is as always to keep the BHP as stable as possible, but as will be shown later this might not always be as easy as one could wish. If the fluid system you are dealing with is quite stable, performing a connection might not be a problem at all, and only small adjustments with the choke will be sufficient to keep the BHP fluctuation to a minimum. I have divided this chapter in two parts. First I am looking at an over pressured reservoir and how to make a connection under these circumstances. My goal is to investigate how one can keep the BHP stable during the connection. In the second part I look at connection making when drilling an under pressured reservoir. My goal here is to analyze the problem of separation of fluids in the annulus when there is no circulation and to try to find a method to mitigate this.

5.2.1. Over pressured well

Figure 5.10 shows how making a connection impact on the BHP when drilling an over pressured well. The reservoir being drilled is containing a volatile oil, and having a reservoir pressure of 300 bar. Because of the high reservoir pressure a 0,82 sg base oil alone, without added gas, can be used to obtain a sufficient underbalance with a flow rate 800 lpm. **Figure 5.11** is showing the influx of formation fluids during the drilling process, **Figure 5.12** the liquid flow rate in and out of the well during the operation and **Figure 5.13** the variation in choke opening.

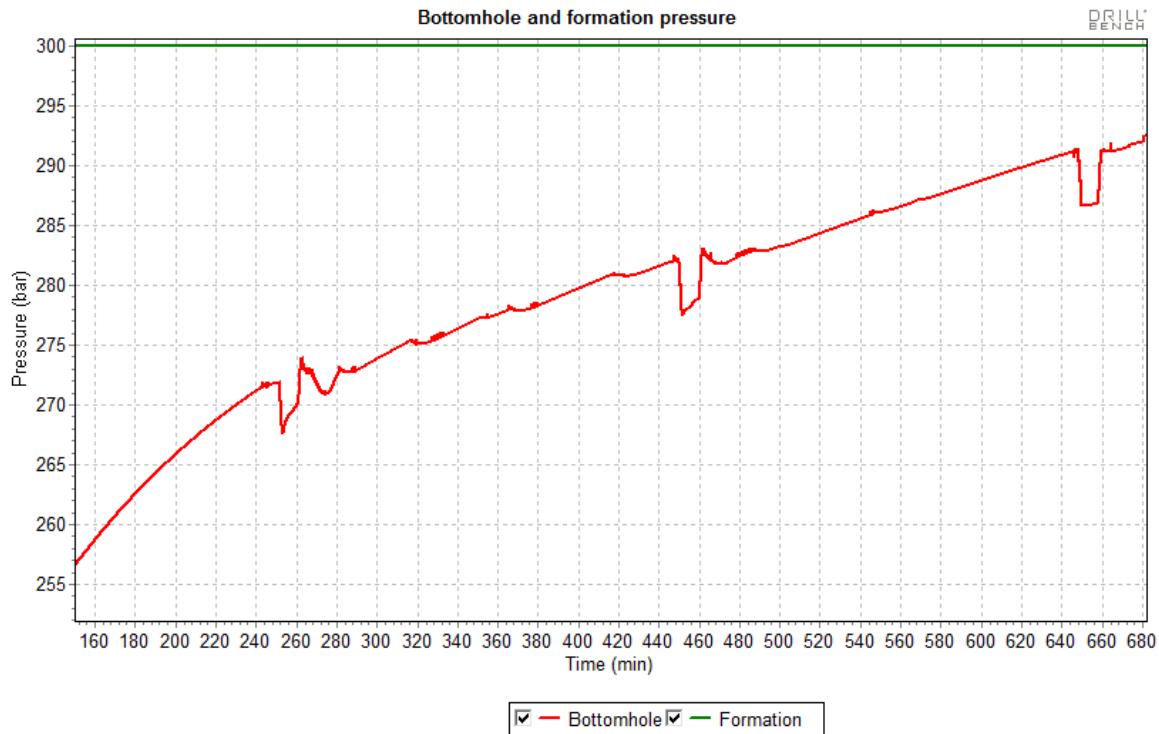

Figure 5.10 BHP over pressured well - connection

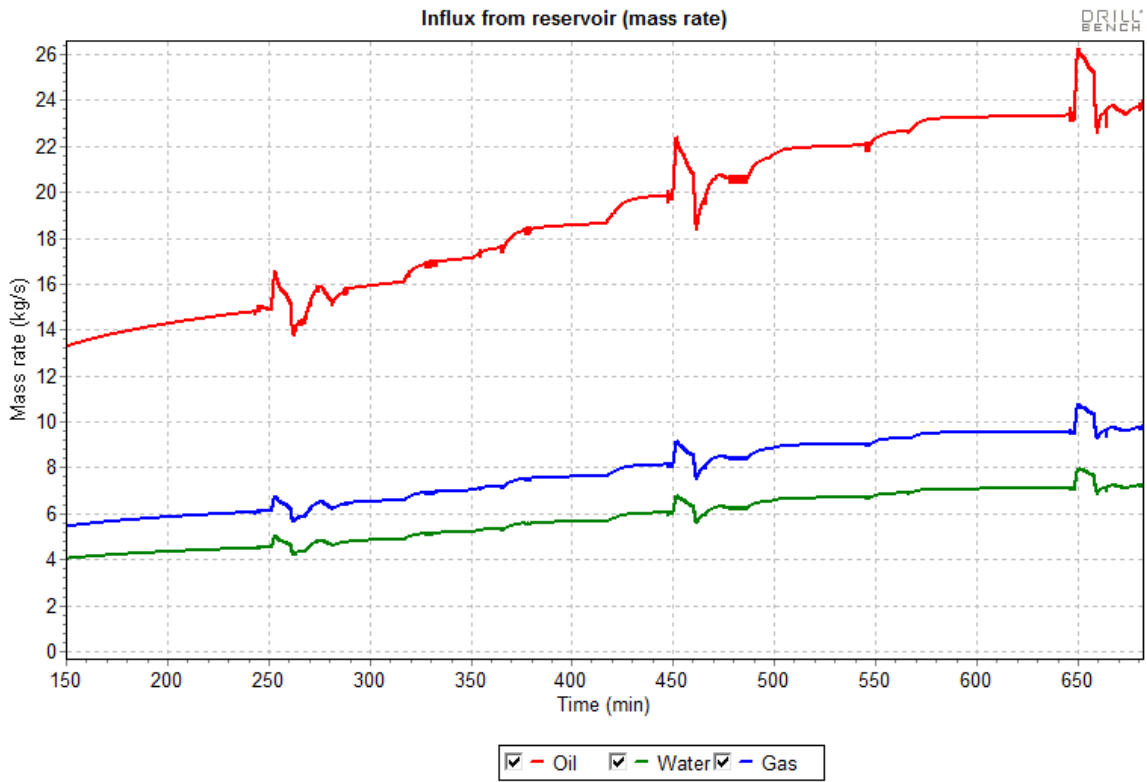

Figure 5.11 Influx over pressured well – connection

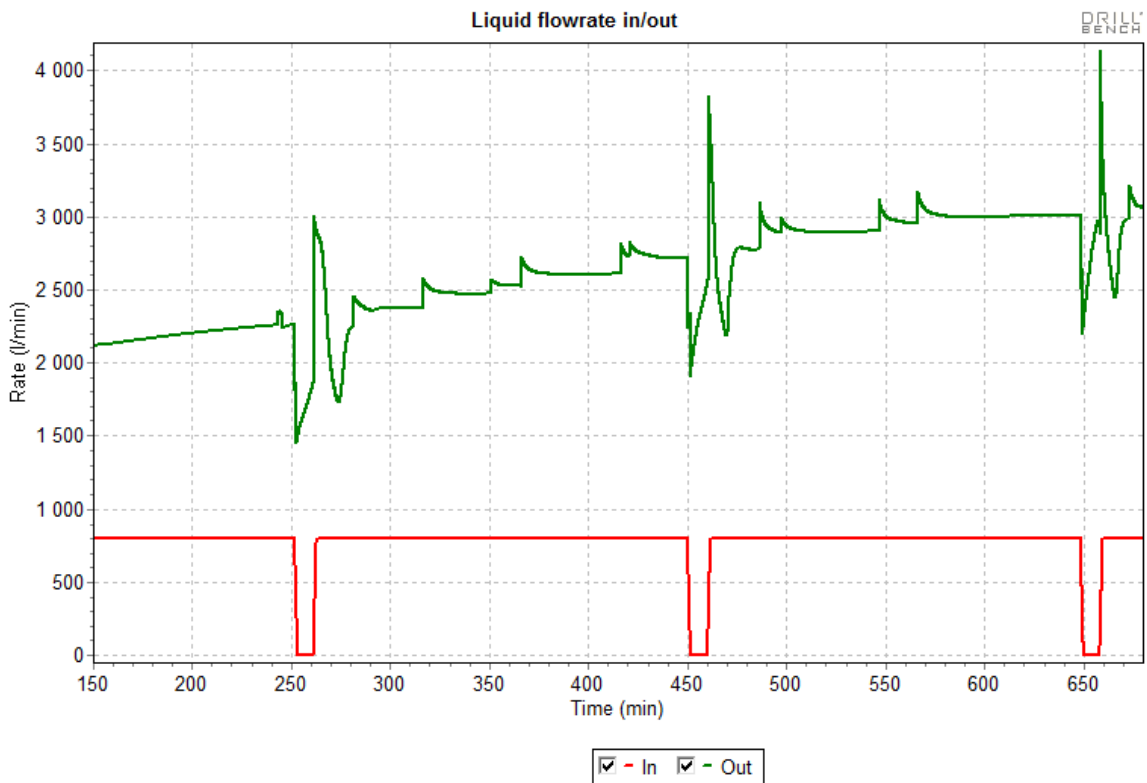

Figure 5.12 Liquid rate in/out over pressured well – connection

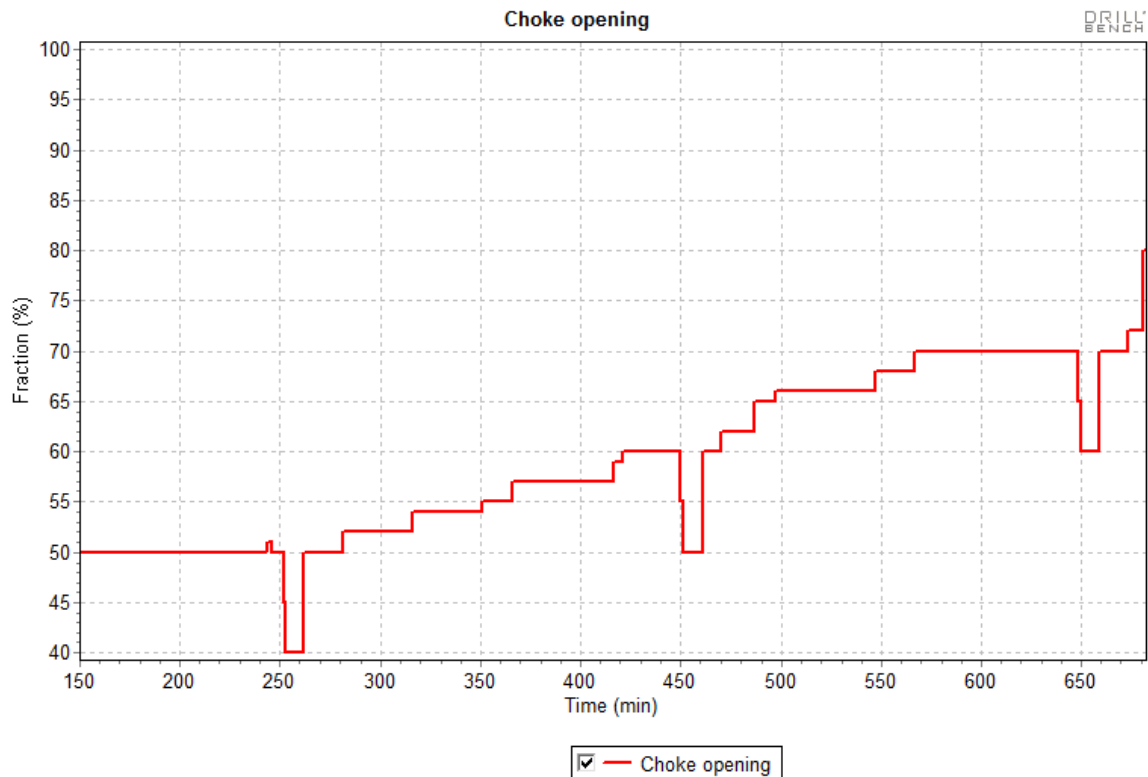

Figure 5.13 Choke opening over pressured well – connection

On **Figure 5.10** we see the connection procedure as the three anomalies on an otherwise quite stable curve. On **Figure 5.11** we see three corresponding anomalies at the same time as on the BHP curve since the influx will vary with the BHP. We see from **Figure 5.13** that the choke opening is varying throughout the entire operation, also outside the connections. That is because as the well gets longer and longer the hydrostatic and friction pressure increases and when the same fluid and rate properties are maintained, the choke must be opened more and more to avoid too big increases in the BHP.

When simulating these connections I have used the following procedure: When the drill pipes reach the drill floor I set the ROP to be zero and circulated with the same rates as before until the pressure was quite stable, then I turned off the pumps and reduced the choke opening with five percent as seen on **Figure 5.13**. **Figure 5.10** shows that a small drop in the BHP occurs as a result of the lost friction pressure when the pumps are turned off. To counteract the pressure drop I closed the choke another 5 percent and the pressure stabilizes, then I let the pumps be off for about ten minutes to simulate the time of a connection. When the ten minutes had passed I started up the pumps again, and then increased the choke opening back to its original level. The starting of the pump can be seen as the increase in BHP after the stable period. I always started the pumps up before I increased the choke opening to avoid a further drop in the BHP. As seen on **Figure 5.10** the BHP increases to a top level and then alternates a bit before stabilizing. The reason for

this alternation is that we are dealing with a multiphase flow system where the turning on of the pumps at the drill pipe side of the system don't give an immediate response at the outlet of the well at the annulus side. When the pumps are turned off and the BHP drops due to the lack of friction pressure the GLR is changed. The pressure drop leads to an increased influx of gas from the reservoir and that more gas goes out of solution from the oil and mud mixture at the bottom of the well. **Figure 5.14** shows the free gas level in the well just before the pumps are turned off, and when they have been off for some minutes.

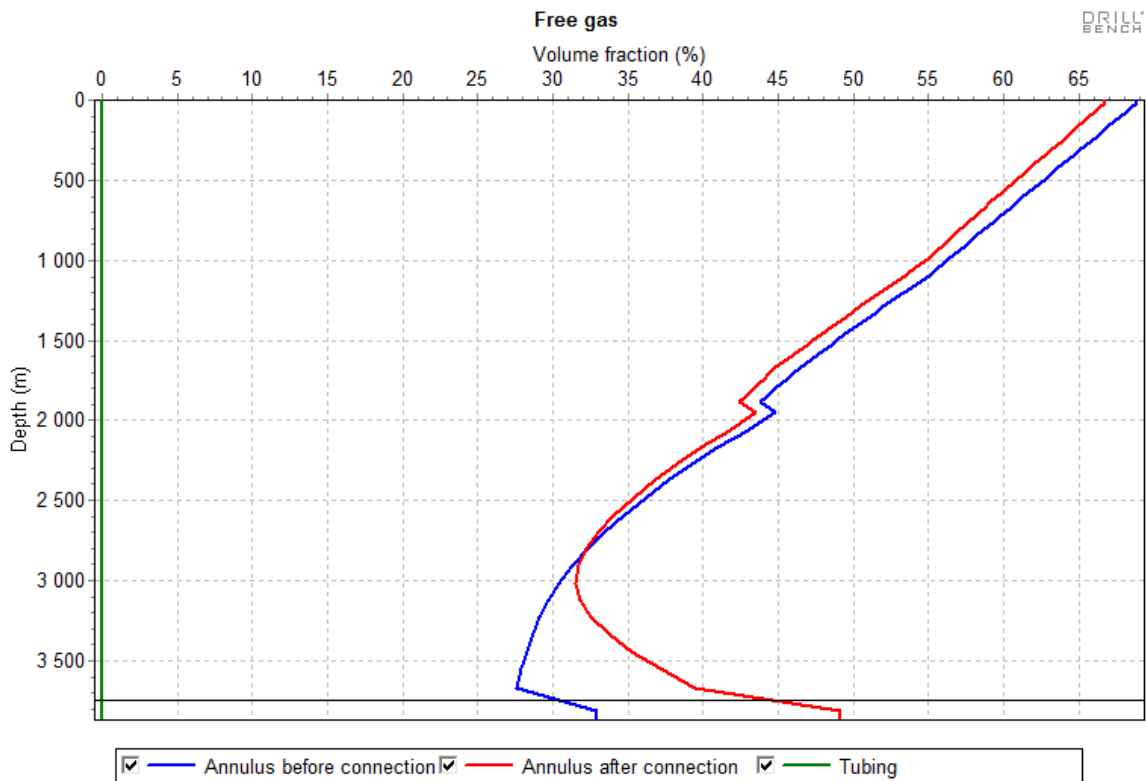

Figure 5.14 Free gas before and after stopping pump over pressured well - connection

Here we see that the free gas volume fraction at the bottom of the well increases from about 33 percent before stopping the pump to around 49 percent after stopping the pump. When turning the pumps back on some time is needed before the GLR is back at the same level as it was before, and this leads to the alternating pressure and flow of fluids from the well.

To summarize one can say that the simulation of this well shows that keeping the BHP relatively stable during connections, despite the fairly big amount of gas in the well, is not a very big problem. Because the well is flowing during the entire connection the choke can be used to regulate this flow and thus the pressure in the well. Only small regulations of the choke opening are necessary to obtain a BHP that only fluctuates in the range of 5 bars. It is important to do such a simulation as the one above before a drilling operation to develop a procedure for the connections. You will then be able to keep the BHP inside the pressure limitations also during a connection.

5.2.2. Under pressured well

5.2.2.1. Pressure spikes during connection

When drilling an under pressured well making a connection can offer greater challenges than those present when drilling an over pressured well. Since the well is not able to flow to surface without the help of a fluid being circulated in the well, the flow of liquids from the well will stop when the pumps are turned off. To achieve a low enough BHP gas can be mixed in the drilling fluid to lower the density. This can lead to a quite high GLR which can make the fluid system more unstable.

A known problem related to the drilling of under pressured wells is the separation of gas and liquid when there is no circulation in the well. Due to buoyancy and inertial forces the gas will continue to flow up the annulus and the liquid will flow back down. (Perez-Tellez, 2003) This will over time lead to an increased BHP. In a worst case scenario the BHP can increase over the formation pore pressure and kill the well. For this to happen normally quite some time without circulation will be necessary, this issue will therefore be further discussed in a later chapter.

Figure 5.15 shows what can happen during a connection if this problem is not taken into consideration during the planning phase of the operation. Below I have depicted a kind of “worst case scenario” regarding the separation of fluids, where nothing is done to prevent the separation. As we see the BHP can spike to a level which exceeds the formation pressure and cause an overbalanced situation which can damage the reservoir. **Figure 5.16** depicts how the influx of formation fluids reacts to changes in the BHP caused by the separation, and **Figure 5.17** shows how the flow from the well stops when the pumps are turned off since the reservoir are not able to transport liquid to surface on its own. The choke opening was 100% open all the time, but the wellhead pressure was sat to 10 bar during the entire operation.

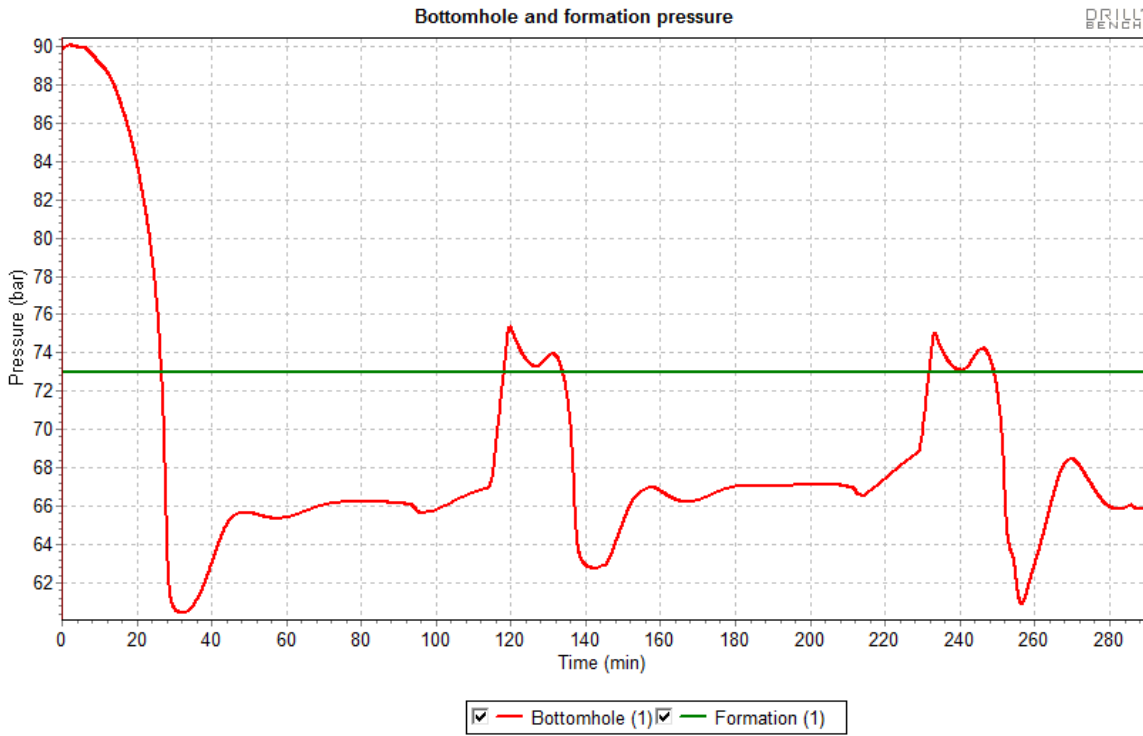

Figure 5.15 BHP - separation of fluids

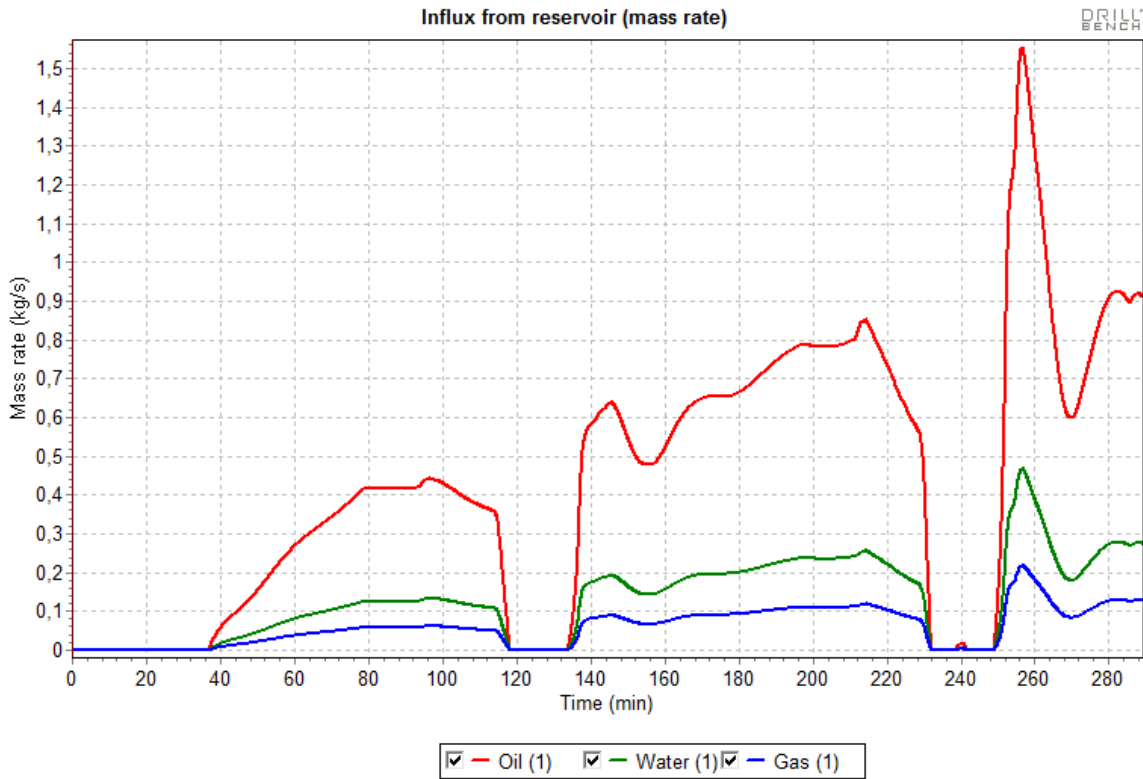

Figure 5.16 Influx - separation of fluids

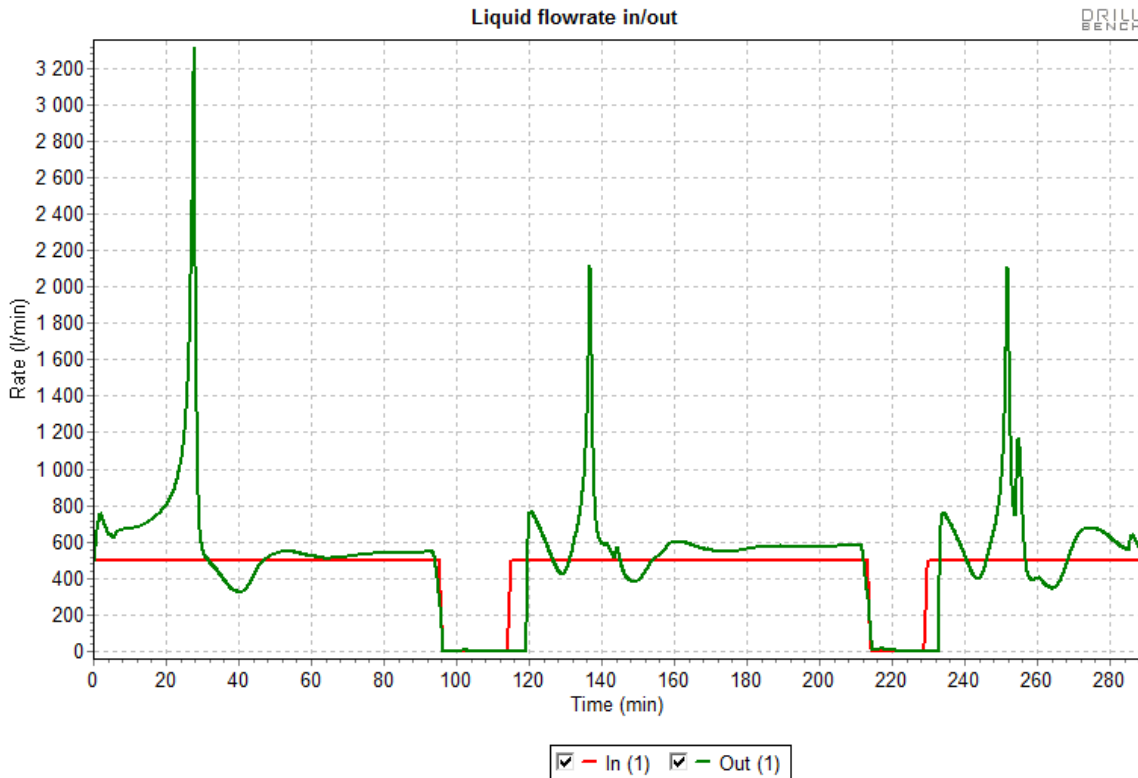

Figure 5.17 Liquid rate in/out - separation of fluids

On **Figure 5.15** we see the performing of two connections while drilling the well. (*The time between connection one and two is not sufficient to drill one stand, but I have chosen to do it like this for a better illustration of the phenomenon.*) This is a classic example of the consequences of separation of fluids in the well. The actual drilling starts after about 50 minutes when the desired underbalance is reached, and continues till about 90 minutes. There we see a small drop in the BHP which comes from the halting of both the liquid and gas injection. While the pumps are off we see that the BHP starts to rise. This is a result of the separation of gas and liquid in the well. A corresponding decrease in the influx of formation fluids can be seen on **Figure 5.16** at the same time as the BHP increase. **Figure 5.17** shows how the flow from the well halts and stays at zero through the entire connection. **Figure 5.18** illustrates the separation process by showing the distribution of free gas in the well before the pumps are turned off, and when they have been off for about 15 minutes.

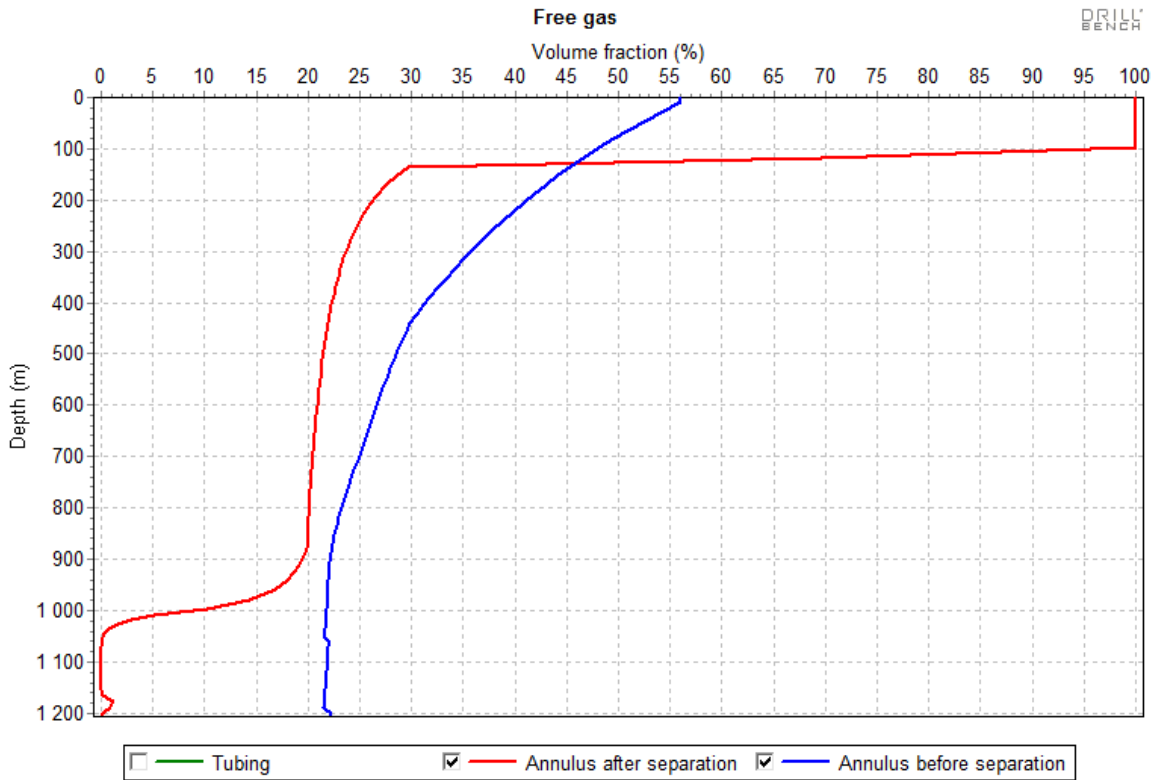

Figure 5.18 Free gas before and after separation

Here we see that while there is circulation in the hole we have gas distributed through the whole well. When the separation has taken place we see that the first 100 meters or so at the top of the well contains 100% gas, and the last 150 meters contains almost 100% liquid. Since the pure liquid has higher density than the liquid mixed with gas, this is the start of a process that increases the BHP due to the acting of a new and heavier hydrostatic pressure column on the bottom of the well. **Figure 5.19** can help explaining this a bit closer. This figure shows the pressure distribution in the well before and after the separation process.

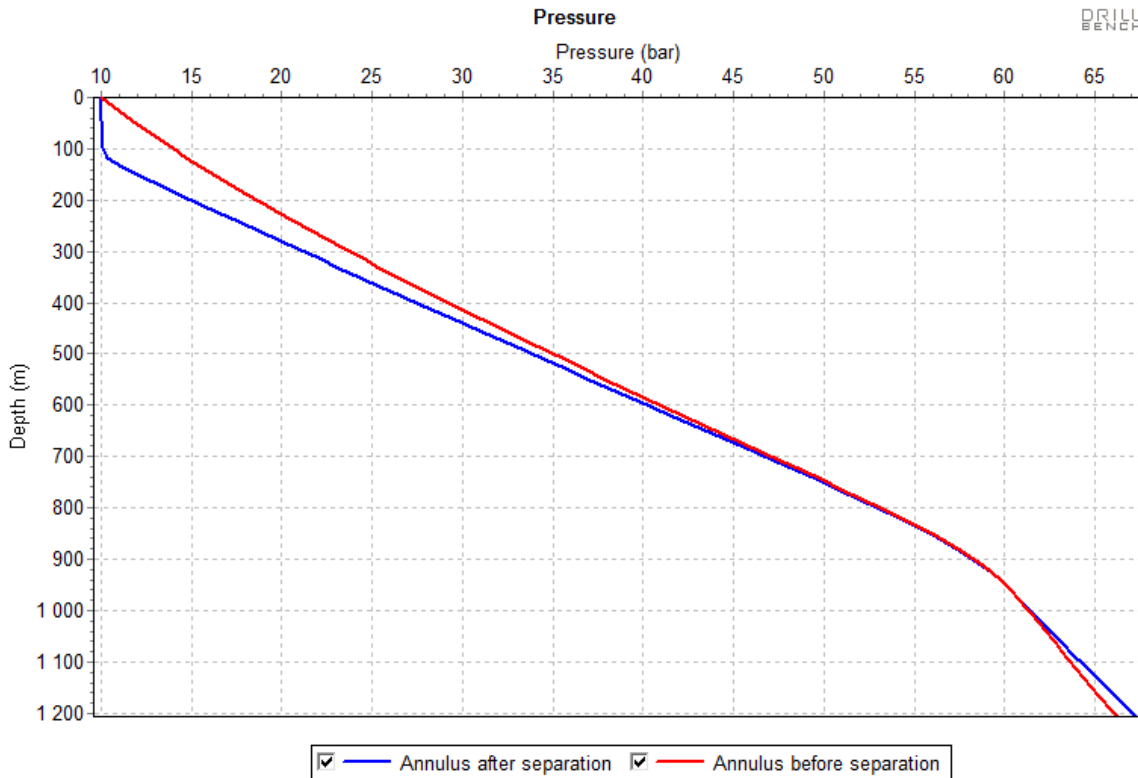

Figure 5.19 Pressure in annulus before and after separation

We know that liquid have higher density than gas and therefore lead to a hydrostatic pressure column where the pressure increases faster with depth than in a column with gas. This is easily explained mathematically by looking at the following equation.

$$p_{hydr} = \rho_{g,l}gD \quad (5.2)$$

p_{hydr} = hydrostatic pressure [bar]

$\rho_{g,l}$ = density of gas or liquid [kg/m^3]

g = gravity constant, $9,81 \text{ m/s}^2$

D = vertical depth[m]

If we convert this to an expression for the pressure gradient we get the following formula.

$$p_{hydr} = \rho_{g,l}g \text{ [bar/m]} \quad (5.3)$$

Since ρ_g is small when the pressure is low, which it is at the top of the well, p_{hydr} will change little with the depth which is seen on **Figure 5.19** as the close to vertical part of the blue graph at the top of the well. ρ_l gets higher when the gas is separated from the liquid, and will thus increase the pressure gradient which makes the pressure change faster down the well than what it did

before the separation. The result is seen on **Figure 5.19** where the blue graph ends up with a higher pressure at the bottom than the red graph.

When the connection is finished and one wishes to start the circulation again **Figure 5.15** shows what happens then. A pressure spike that exceeds the formation pressure is the result of the separation. First a rapid increase then a rapid decrease in the pressure before it stabilizes. The reason for this behavior is the forming of liquid slugs as a result of the fluid separation. When the pumps are turned on there are basically only liquid at the bottom of the annulus. This slug will have to be circulated out before the pre – connection state can be regained. **Figure 5.20** illustrates the liquid slug on its way up the annulus when the pumps are brought back on.

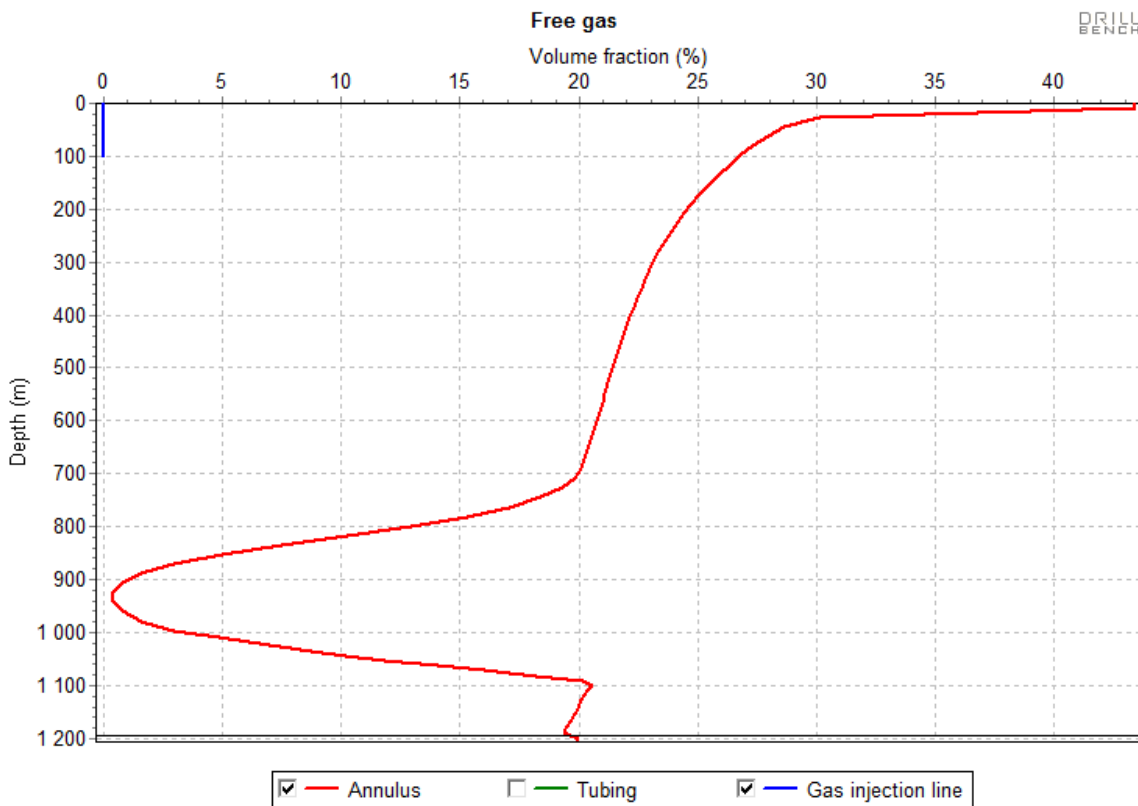

Figure 5.20 Slug moving up the annulus

In addition to the separation in the annulus one will also experience this in the drill string. This will produce liquid slugs here also which will contribute to the pressure instability in the well. When the liquid slugs are pumped into the annulus and start moving upwards, the gas at the top will be “pushed out” of the well leading to an increase in the hydrostatic pressure in the well. This can be seen on **Figure 5.20** which shows that the gas fraction at the top of the well is reduced to about 45%. This along with the frictional pressure coming from the pumps is the force behind the rapid BHP increase seen in **Figure 5.15**. After some minutes the GLR in the drill string is stabilized and a fluid with the desired low density starts to enter the annulus. This will start the process of reducing the hydrostatic pressure in the fluid column, and thus the BHP.

During the first connection on **Figure 5.15** we see that after about 130 minutes the BHP starts to drop again, and then stabilizing on the same level as before at around 160 minutes.

5.2.2.2. Slugging

Figure 5.15 depicts the problem with pressure spikes that exceeds the formation pressure due to gas-liquid separation. There can also be other problems related to this phenomenon. On **Figure 5.15** we see that the BHP goes back to a value which lies around the same level as before the connection and stabilizes there. This is not always the case. Permanent slugging, and thus permanent BHP fluctuation, can be induced by gas-liquid separation. (Perez-Tellez, 2003) **Figure 5.21** shows how such a situation can look.

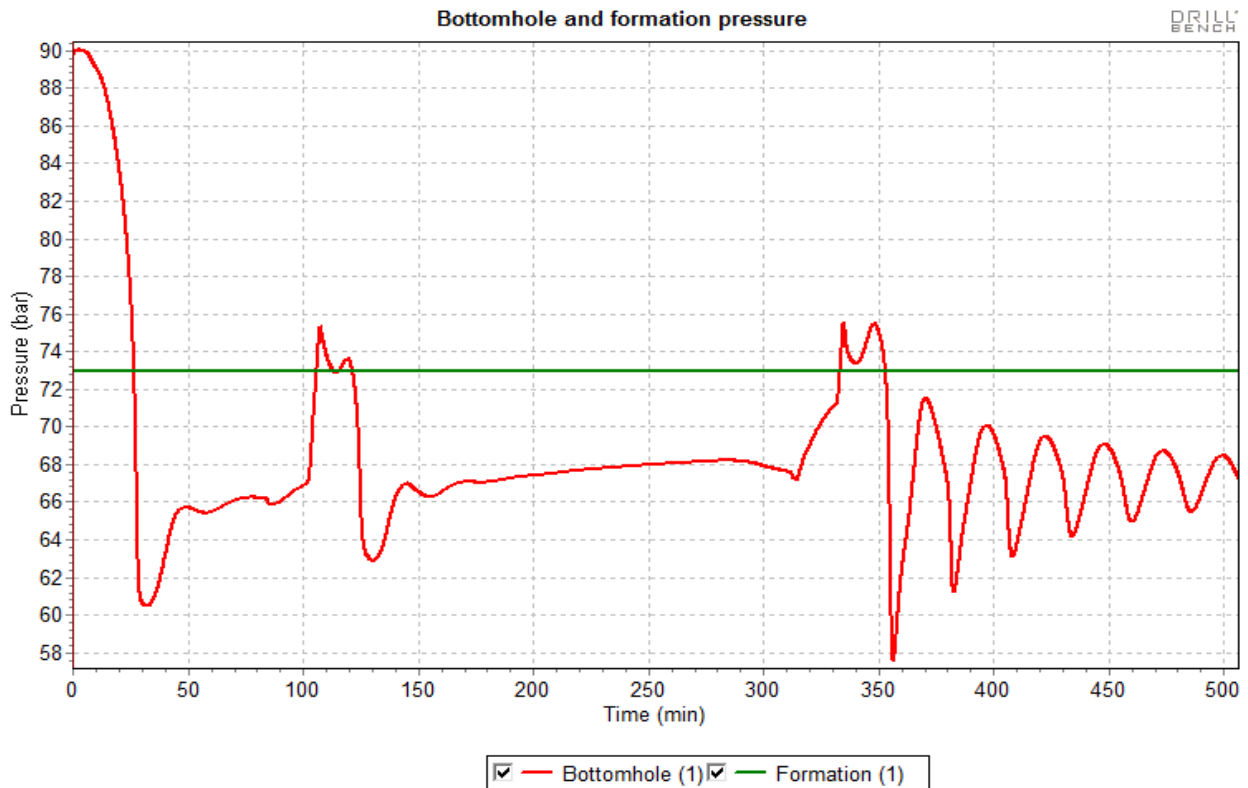

Figure 5.21 BHP during slugging

Figure 5.21 shows the drilling of the same well as in **Figure 5.15** except that here one can see that the time between connection one and two is longer, which in this case means the drilling of a whole stand between the two connections have been simulated here. The same flow rates of gas and liquid, and the same choke opening have been used in the creation of **Figure 5.21** as in **Figure 5.15**. The time between the turning off and on the pumps for the two connections is more or less the same, about 15 minutes. We see that the BHP rises faster during the second separation than the first. The reason for this is that the reservoir part of the well, i.e. the part of the well drilled through the reservoir zone, and therefore the part where the influx of formation fluids occurs, is longer than what it was before the first connection. This then leads to a bigger total influx of formation fluids into the well, which again leads to a faster accumulation of liquid at the

bottom of the well. A higher liquid column from the bottom and upwards formed during the same separation time as during the first connection, is the endpoint of the second separation process. **Figure 5.22** illustrates the difference between the liquid column after the first, and after the second separation.

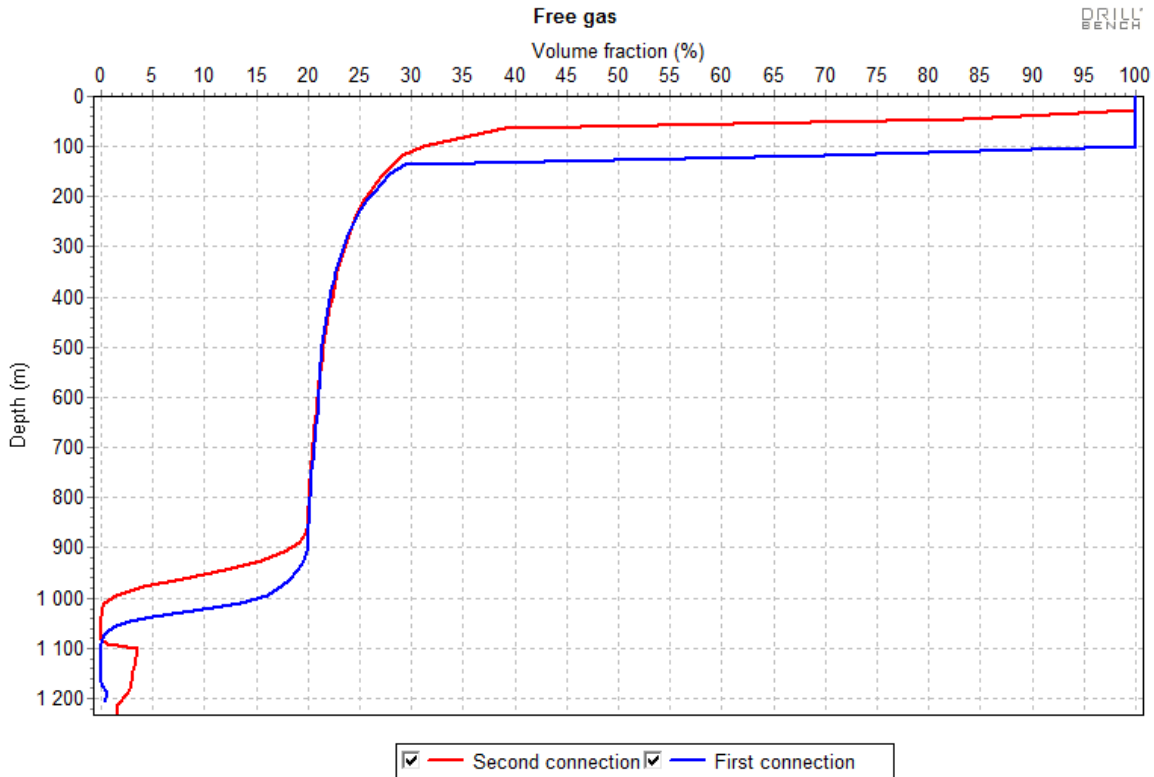

Figure 5.22 Free gas after first and second separation - slugging

By introducing some numbers the difference gets even clearer. For the first connection the reached well depth is 1207 mMD, and the height of the liquid column reaches up to about 1063 mMD. This means that we have a $1207-1063=144$ meters of liquid from the bottom and upwards after the first separation. When the second connection is to be made a depth of 1237 meters is reached. The liquid column has after 16 minutes reached to the height of 1001 mMD. This gives a liquid column of $1237-1001=236$ meters. What we also see here is that there is less gas at the top of the well at the end of the second connection than at the end of the first one. This can be explained by the fact that the well is longer at the second connection, and the gas thus must travel further before it reaches the top. This causes the separation to take a bit longer time at the second connection.

When the connection is finished and the circulation is started again the liquid column formed in the well has to be circulated out. Since the liquid slug after the second separation is bigger than after the first, it will be a bigger part of the hydrostatic pressure column which makes up the BHP. This means that when the slug is removed from the well a larger drop in BHP will be seen since a larger part of the hydrostatic pressure column is removed at once. This large and quick

pressure drop will initiate another large influx of formation fluids which will form another liquid slug. The fact that the reservoir part of the well now is bigger than at the first connection also contributes to a bigger influx. This process will repeat itself, but with smaller and smaller slugs for each time, which can be seen on **Figure 5.21**. The reason for the smaller and smaller slugs is that the first pressure drop, caused by removal of the slug made during separation, is not big enough to cause an equally large influx as the one caused by the separation. Each slug will because of this pattern be smaller than the last. Eventually the BHP will stabilize and the same GLR as before regained, but as seen on **Figure 5.21** this will take several hours.

5.2.2.3. Mitigating problems

When it comes to the problem with slugging it is likely that a too low GLR has something to do with it. (Myktyiw et.al., 2003) When the well gets deeper and the influx from the well bigger and the injection parameters are kept constant the GLR in the simulated well will be reduced over time since the reservoir contains heavy oil with a low gas-oil ratio. To mitigate this, one could increase the amount of injected gas so that the GLR is being better maintained. **Figure 5.23** shows the drilling of the same well as in **Figure 5.21**, but with an increase in the gas rate from 15000 lpm to 22000 lpm, and an increase in the back pressure from 10 to about 13 bar after 140 minutes. The choke is adjusted to obtain the same BHP as the one in **Figure 5.21**. As seen on **Figure 5.23** the result is a quickly stabilized BHP after the second connection. This is of course not a good solution overall because of the big BHP spike caused by the increased friction pressure due to the increased gas rate, but the point here was to compare the same situation with and without slugging.

The choke can also be used to reduce the slugging after a connection. **Figure 5.24** shows the drilling of a well under the same conditions as in **Figure 5.21**. We see that by regulating the choke, as done after the first connection simulated, one can reduce the slugging tendency significantly by closing the choke as the BHP starts to drop the first time, and then opening it up again step by step until the previous conditions are regained. **Figure 5.25** shows how the choke opening was changed during the simulation. For the second connection nothing was done to prevent the slugging and we see that severe fluctuations in the BHP are encountered.

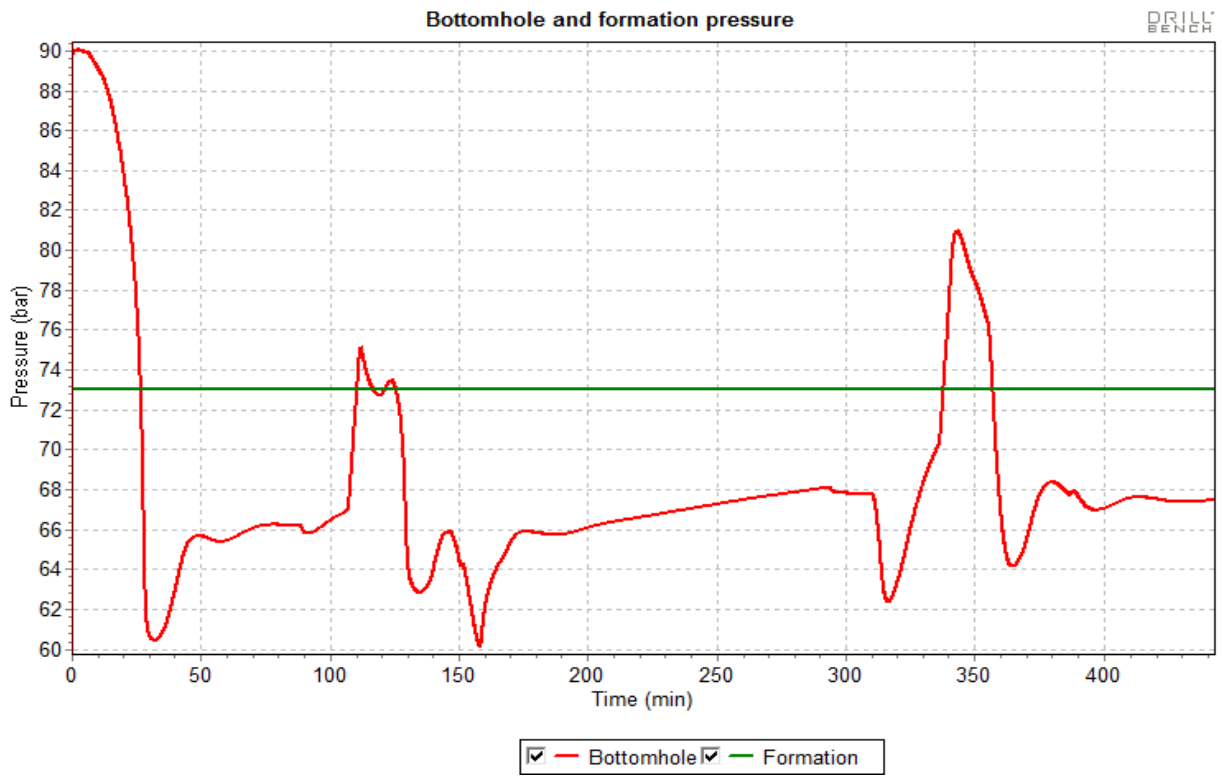

Figure 5.23 BHP - slugging avoided

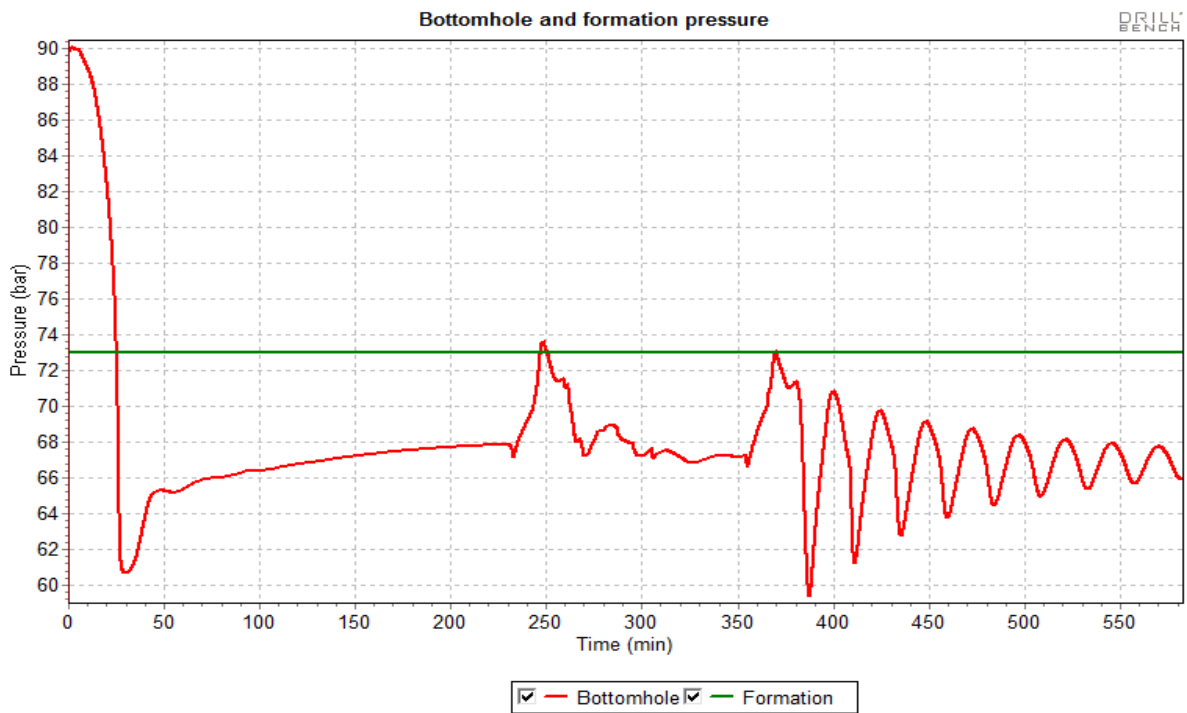

Figure 5.24 BHP-reducing slugging with choke

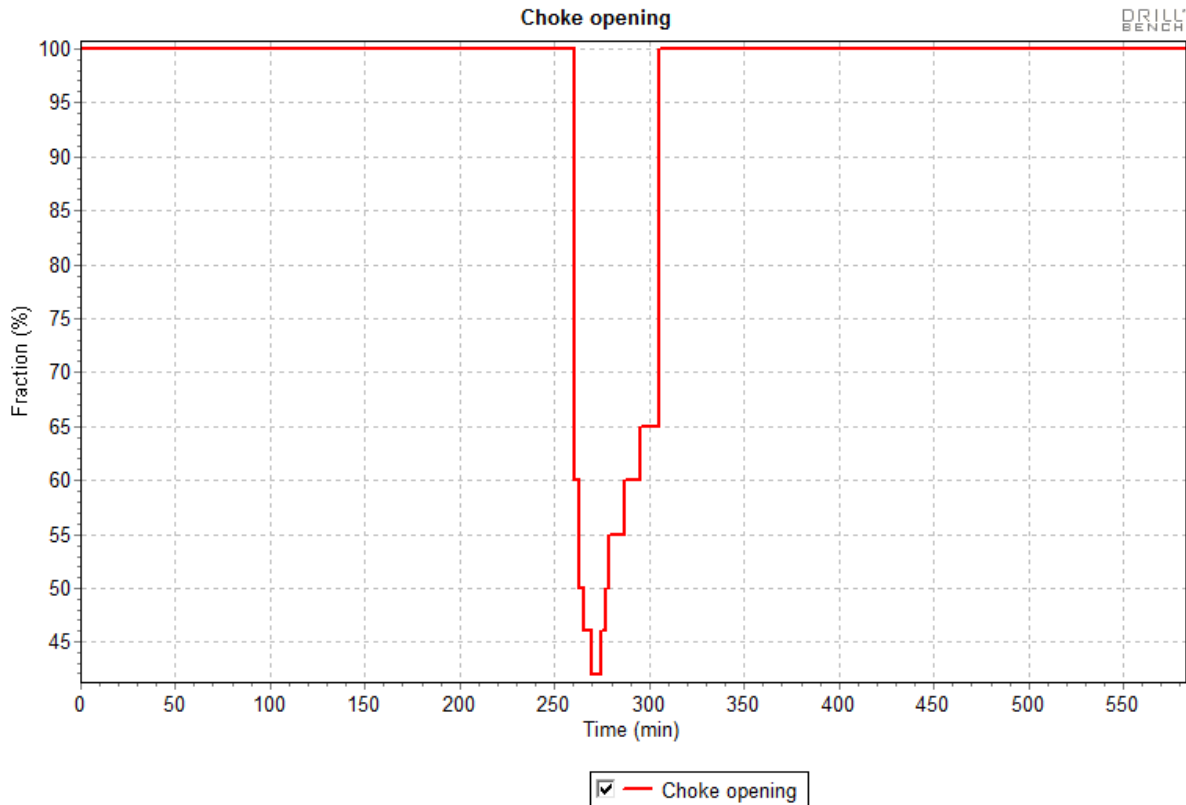

Figure 5.25 Choke opening-reducing slugging with choke

To mitigate the BHP fluctuations caused by the separation of fluids there are some measures that can be taken. In the examples above the drill string gas injection method is being used. If you switch to another method like the parasite string or concentric casing injection method circulation can be maintained throughout the entire connection. This will prevent any separation from happening and thus prevent the big BHP fluctuations. The drawback with this method is that it is not always suitable since modifications need to be made to the wellhead and along the well path to make it work. This of course increases the cost of the well. Another method could be the use of a Continuous Circulation System (CCS). This system allows you to make a connection while circulating since the connection is performed inside a pressurized chamber standing on the drill floor. (Rehm et.al., 2008)

If none of the above mentioned systems is to be used and the gas will be injected through the drill string the only tool you have at your disposal is the choke. By regulating the choke it is possible to delay the separation process and control the transportation of the liquid slug in such a way that the BHP fluctuations can be kept at a much lower level than if nothing is being done. In the above examples I described a “worst case scenario” with severe separation so that I was able to describe the phenomenon in a good way. Now I will describe a bit more realistic system and how one can use the choke to minimize the problems related to separation of fluids. **Table 5.3** shows the parameters used in the simulation.

Wellhead pressure	5 bar
Liquid rate	500 lpm
Gas rate	20000 lpm
Back pressure	10 bar – choke opening: 39%

Table 5.3 Parameters - realistic separation case

Wellhead pressure or separator pressure is the lowest possible pressure at the choke, i.e. the lowest pressure the reservoir needs to overcome to bring fluids to surface. **Figure 5.26** shows the BHP development when performing two connections. First I simulated a connection where I didn't regulate the choke. I only let the pumps be off for 10 minutes and then started them again. Afterwards I simulated a connection where I regulated the choke during the connection to minimize the BHP fluctuations. **Figure 5.27** and **Figure 5.28** show how the choke pressure developed, and how I regulated the choke. The flow of liquids through the choke is shown in **Figure 5.29**.

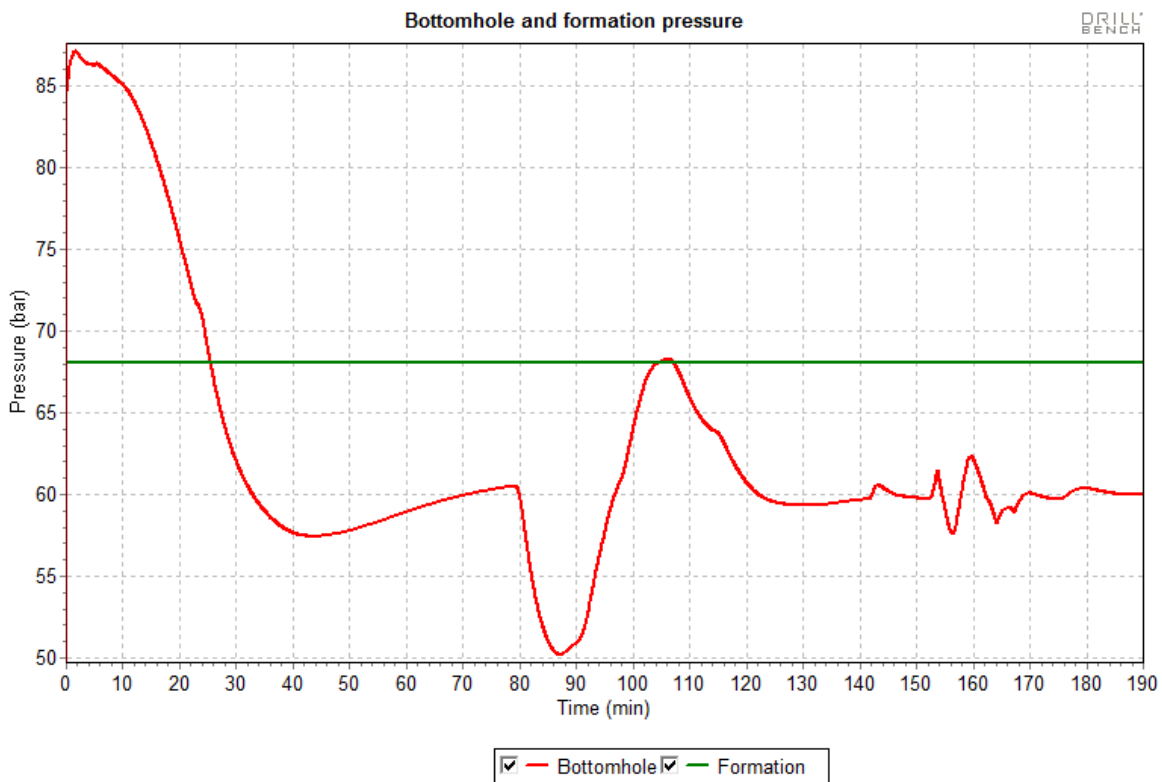

Figure 5.26 BHP - mitigating separation with choke

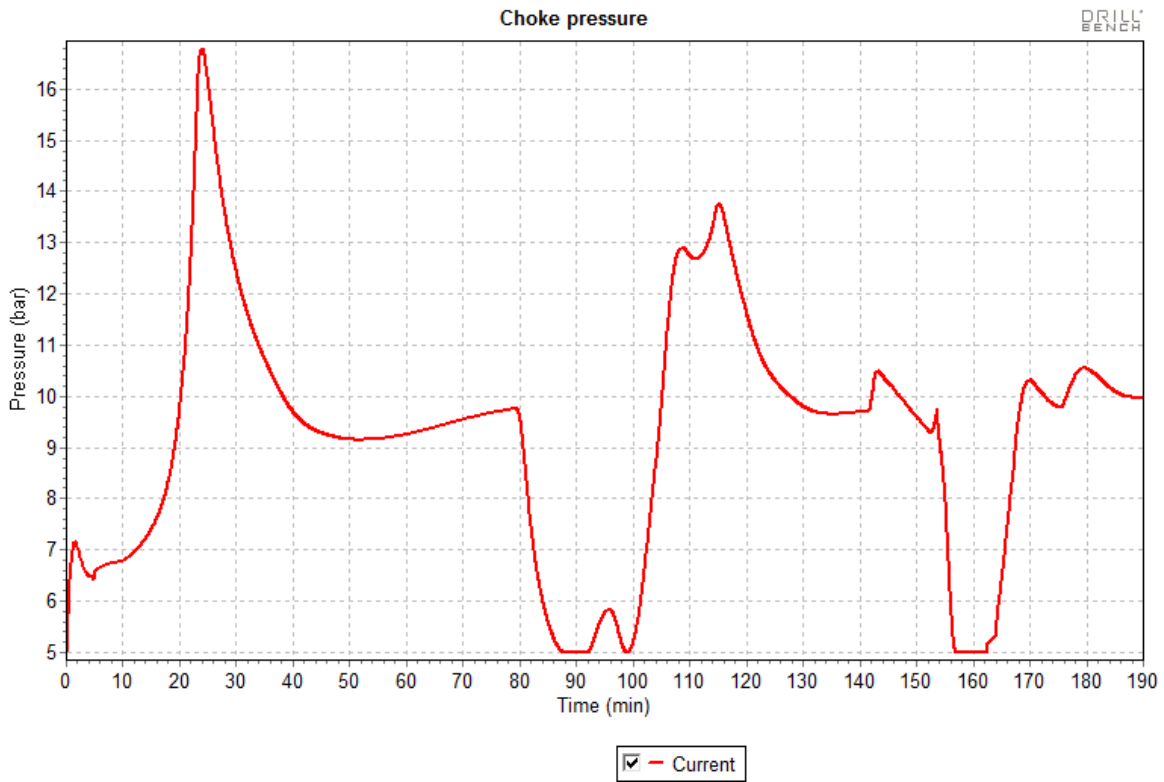

Figure 5.27 Choke pressure - mitigating separation with choke

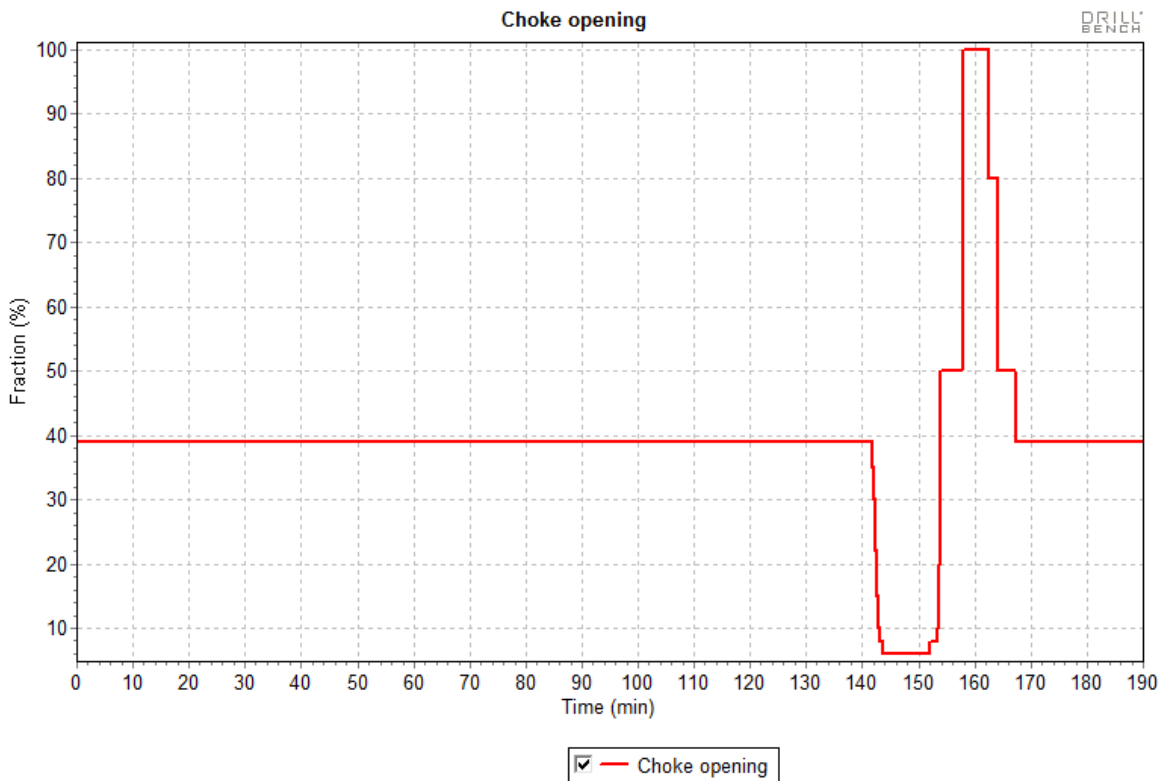

Figure 5.28 Choke opening - mitigating separation with choke

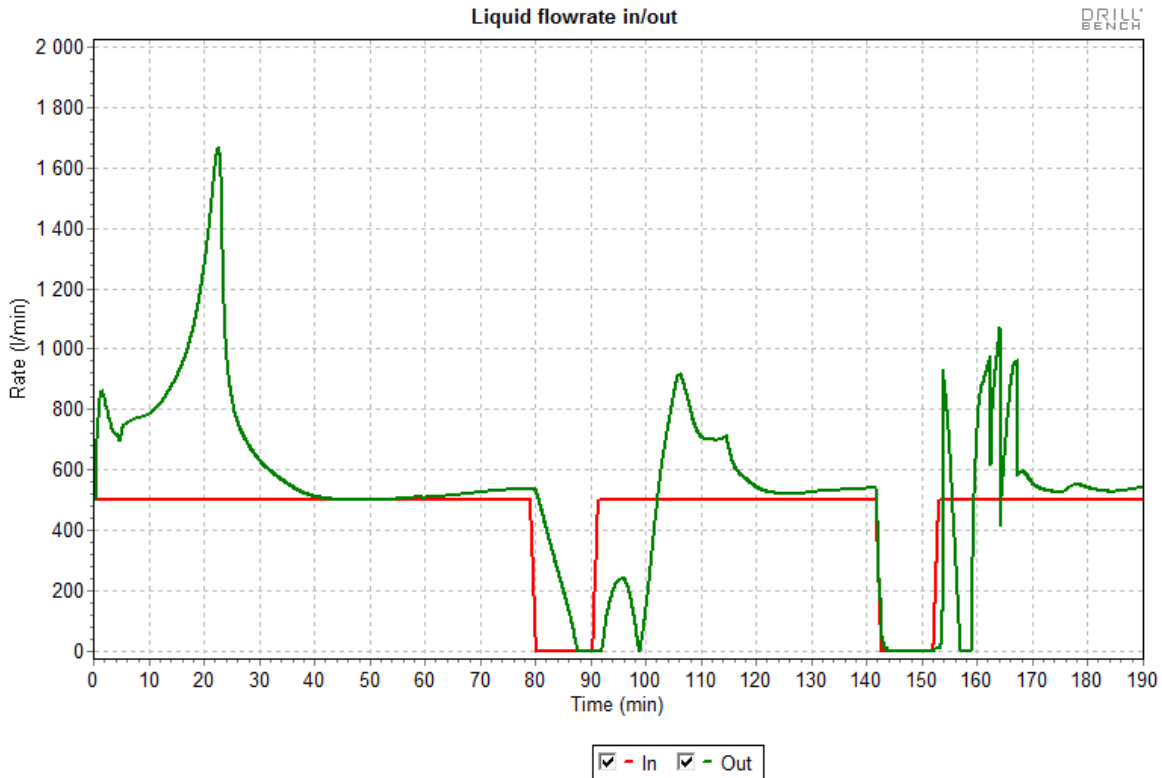

Figure 5.29 Liquid rate in/out - mitigating separation with choke

We see on **Figure 5.26** that for the first connection we get a large BHP fluctuation of nearly 10 bar below and above the BHP before the connection. The reason for the first drop is the loss of friction pressure provided by the 39% open choke when the pumps are turned off. We then see that the BHP starts to rise in the same way as in the example about separation earlier. That is due to the separation of gas and liquid in the well. When the pumps are started again the liquid slug needs to be circulated out and a spike in the BHP which exceeds the formation pressure can be observed. When looking at the next connection the situation is quite different. Here we see a much more stable BHP. To obtain this I used the choke to first counteract the loss of friction pressure and then to regulate the out-circulation of the liquid slug.

To prevent the BHP drop due to the loss of friction pressure I closed the choke step by step, as seen on **Figure 5.28**, so that the liquid rate from the well was reduced approximately at the same rate as the liquid rate into the well. We see the difference between the two connections in **Figure 5.29** where the flow out of the well stops several minutes after the flow in for the first connection, whilst at the second one we see the in and out flow reducing nearly at the same rate. The difference between the two connections is also visible on **Figure 5.27**. For the first connection we see that the choke pressure drops to 5 bar after 80 minutes which is the same time as the pumps are shut off. For the second connection the pumps are shut off after 140 minutes, but here we don't see a drop, we see a small increase which comes from the closing of the choke whilst the pumps are shutting down. To sum up a bit we can now say that we have "trapped" some

pressure in the well by the closing of the choke. This prevents the BHP from dropping and we have taken care of the first major pressure fluctuation we see during the first connection.

When the pumps are off we get separation of fluids in the well also during the second connection, so when the pumps are started up again we need to circulate out a liquid slug. When the pumps are started the friction pressure in the well increases, and as we see on **Figure 5.26** the BHP starts to rise. To prevent a high BHP increase due to the friction pressure I now started to open the choke again. **Figure 5.28** shows how this was done. The opening of the choke leads to a drop in the BHP since the “trapped” pressure is being released. **Figure 5.27** shows that the choke pressure is reduced to 5 bar at about 156 minutes which is the same time as the choke is opened from 20% to 50%. After this drop the BHP starts to rise again. I then opened the choke fully, from 50% to 100%. What remains of the liquid slug in the well is being circulated out and the BHP starts to drop again. To get back to the same BHP as before I then close the choke stepwise as seen in **Figure 5.28** until the opening is back at its original level. At the end one can mention that since this use of the choke prevents big BHP fluctuations it will also prevent the start of long-lasting slugging problems such as seen in **Figure 5.21**.

5.2.3. Conclusion

For an over pressured reservoir which provides enough pressure to bring fluids to surface at all times we have seen that keeping the BHP on reasonably stable level is not a very big challenge. As long as the well is flowing you can use the choke to control the flow from the well, and thus the BHP.

Making a connection when drilling an under pressured well may, as we have seen, offer a greater challenge than for an over pressured one. Separation of fluids can lead to severe fluctuations in the BHP. These fluctuations are never desirable since they in a worst case scenario can lead the BHP to cross borders on both the high and low side. By that I mean that the BHP can exceed the formation pore pressure because of an increase in the pressure like illustrated in **Figure 5.15**, or it can exceed the formation collapse pressure due to a decrease like showed in **Figure 5.26**.

Exceeding the formation pressure will lead to an invasion of drilling fluid from the well and into the reservoir formation. Since it is not formed a mud cake on the borehole wall when you drill underbalanced this invasion may be more extensive than during a normal overbalanced drilling operation. This invasion can damage the formation and by that reduce, or even ruin, the benefits of the underbalanced operation. An exceeding of the collapse pressure limit of the formation can lead to borehole stability problems resulting in e.g. a stuck pipe situation. It is important to be aware of the effects caused by the phenomenon that is separation of fluids so that it can be planned for and dealt with in a good way.

We have seen that the choke is a good tool when dealing with separation of fluids. If the regulation is performed in the right manner **Figure 5.26** shows that BHP fluctuations can be reduced from a magnitude of 10 bar to a magnitude of only 2 bar measured from the pre –

separation level. This shows us that the problem of separation of fluids can be manageable without the use of a parasite gas injection system or a CCS system

5.3. Tripping

Performing tripping during an underbalanced operation can be a challenge. The type of well being drilled is determining the challenges, and which measures must be taken to conduct a successful operation. For a well not able to bring fluids to surface without help from the circulating system a tripping operation can cause problems. As for a connection the separation of fluids plays a role during tripping, but it may not be the only issue related to this operation. My goal in this chapter is to have a closer look at the problems occurring during tripping, and possible ways to deal with them.

5.3.1. Challenges

5.3.1.1. Separation of fluids

In the chapter about the performing of connections I discussed the phenomenon of separation of fluids. I mentioned in this regard that in a worst case scenario the BHP could exceed the formation pressure because of separation in a longer time perspective. This is shown in **Figure 5.30** and **Figure 5.31** which shows the BHP against time and the formation fluid influx against time, respectively. The well simulated is the same under pressured well as the one used in the chapter about connections. On these two figures we see that as the time goes the BHP approaches the formation pressure and the influx of formation fluids approaches zero.

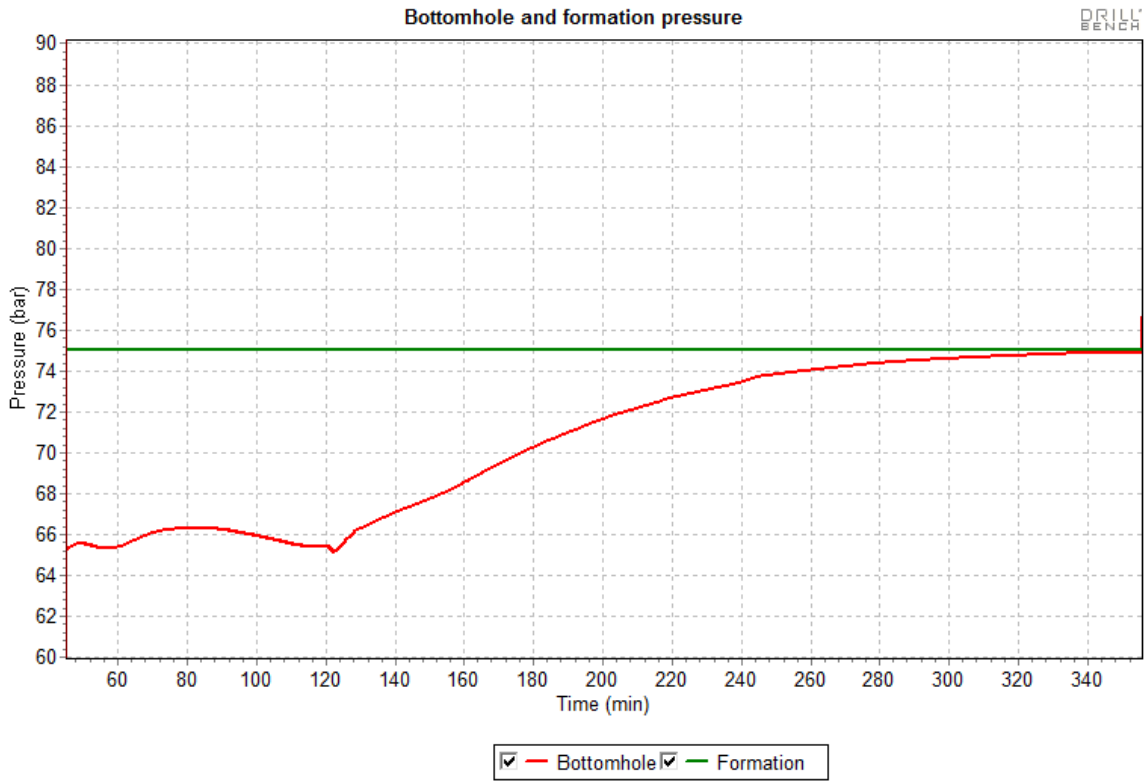

Figure 5.30 BHP - tripping

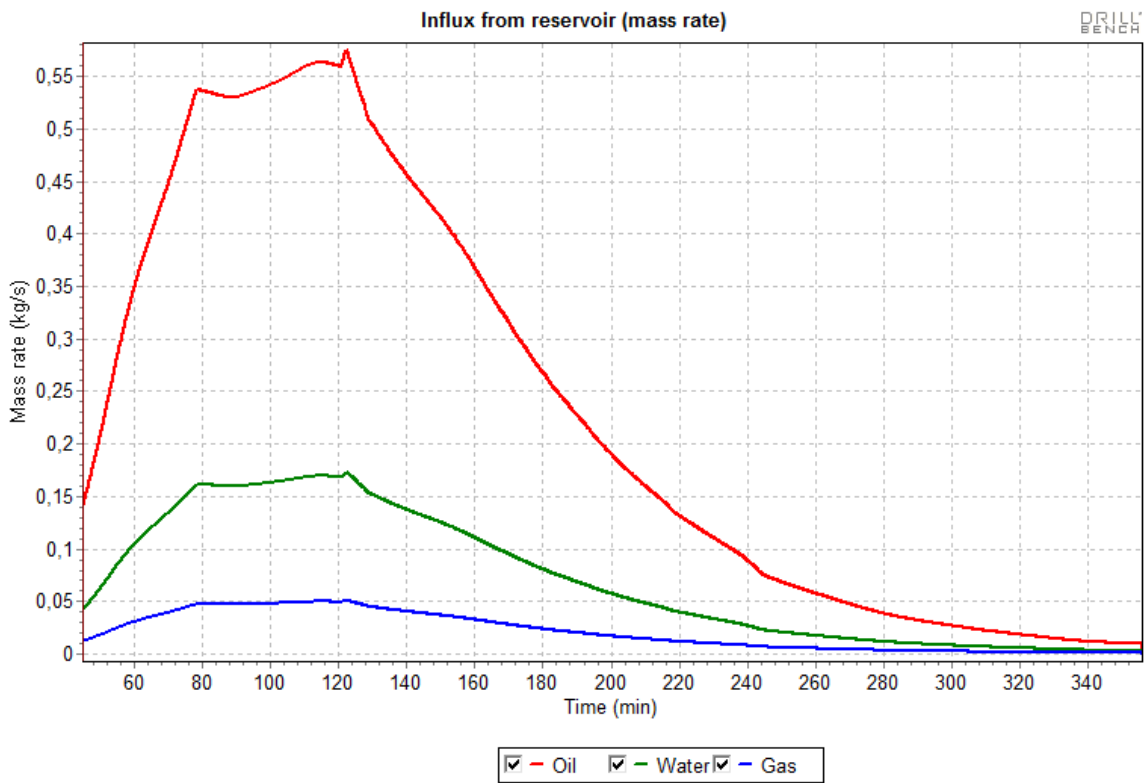

Figure 5.31 Influx - tripping

When performing tripping the pumps will be off for a long time and thus no drilling fluids are entering the hole. The reservoir however, will continue to produce fluids until the BHP equals the formation pressure. Because of the separation process this column will after a time exist entirely of liquids from the bottom and up to a certain point in the well, and entirely of gas from this point to the top. This will, as seen under the connections, lead to an increased BHP since a liquid column with higher density will be formed. **Figure 5.32** shows the distribution of free gas in the well after a full separation process. The difference in the pressure columns from before and after the separation is depicted in **Figure 5.33**.

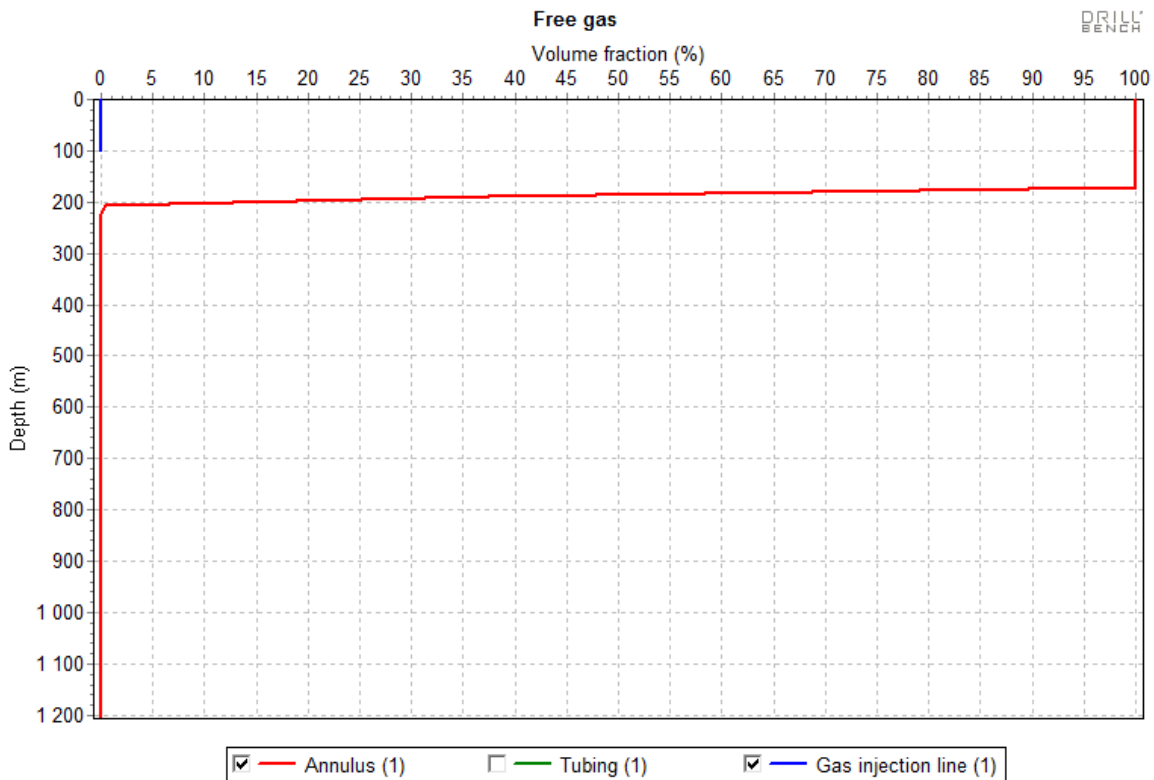

Figure 5.32 Free gas in the well during tripping

Here we see an almost complete separation process with gas on top and liquid from about 200 meters and down.

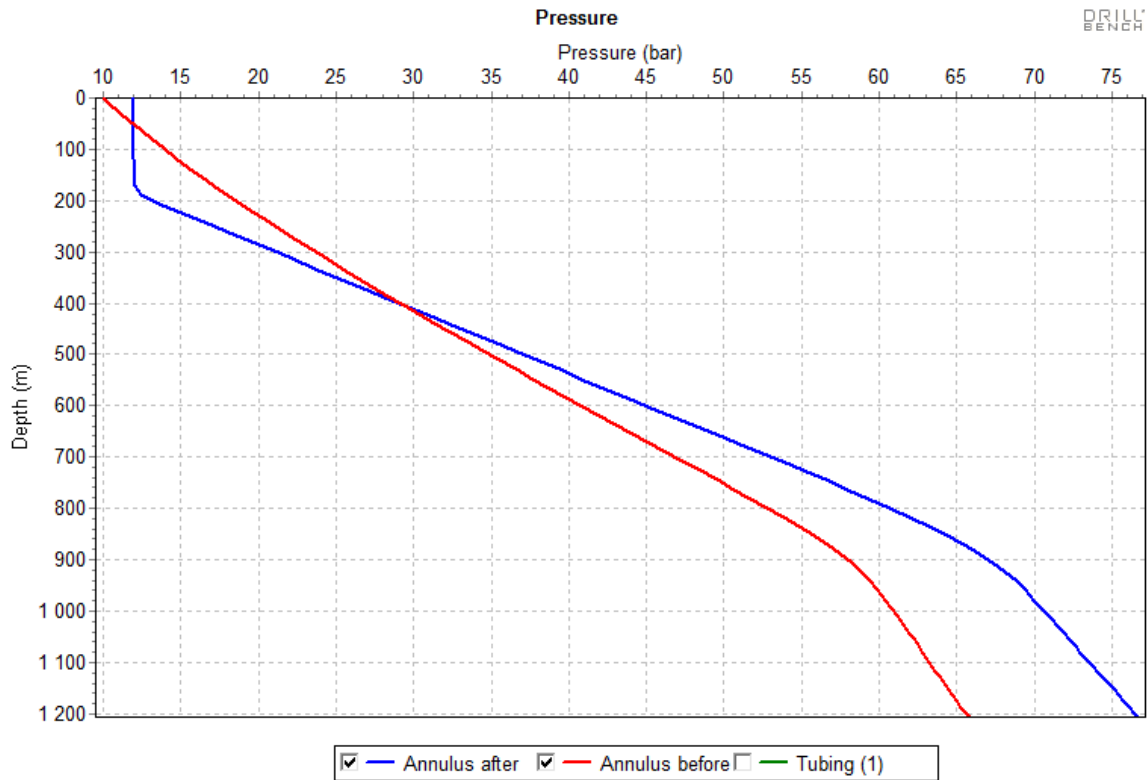

Figure 5.33 Pressure in annulus before and after separation - tripping

Here we see the development in the pressure column in the well due to the change in the density. We see that when the gas separates from the liquid the density increases and the pressure increases faster down the well. At the end point of the separation, which is when the formation stops flowing, the BHP have actually increased with 11,2 bar from 65,3 bar before the separation to 76,5 bar after the separation.

5.3.1.2. Heavy oil

For an under pressured well you can experience problems during tripping besides the gas – liquid separation issue. Even for reservoirs containing heavier oil with low gas-oil ratios (GOR) the well will eventually kill itself. **Figure 5.34** shows the BHP development during tripping for the same type of well as before, but with a different reservoir fluid and pressure. This reservoir contains heavy oil with a low GOR. The pore pressure however, is so high that it is possible to drill the well without using gas in the drilling fluid. The drilling fluid therefore consisted only of the base oil used when simulating the wells mentioned above. The liquid rate was the same as before. **Figure 5.35** shows the influx of the formation fluid against time.

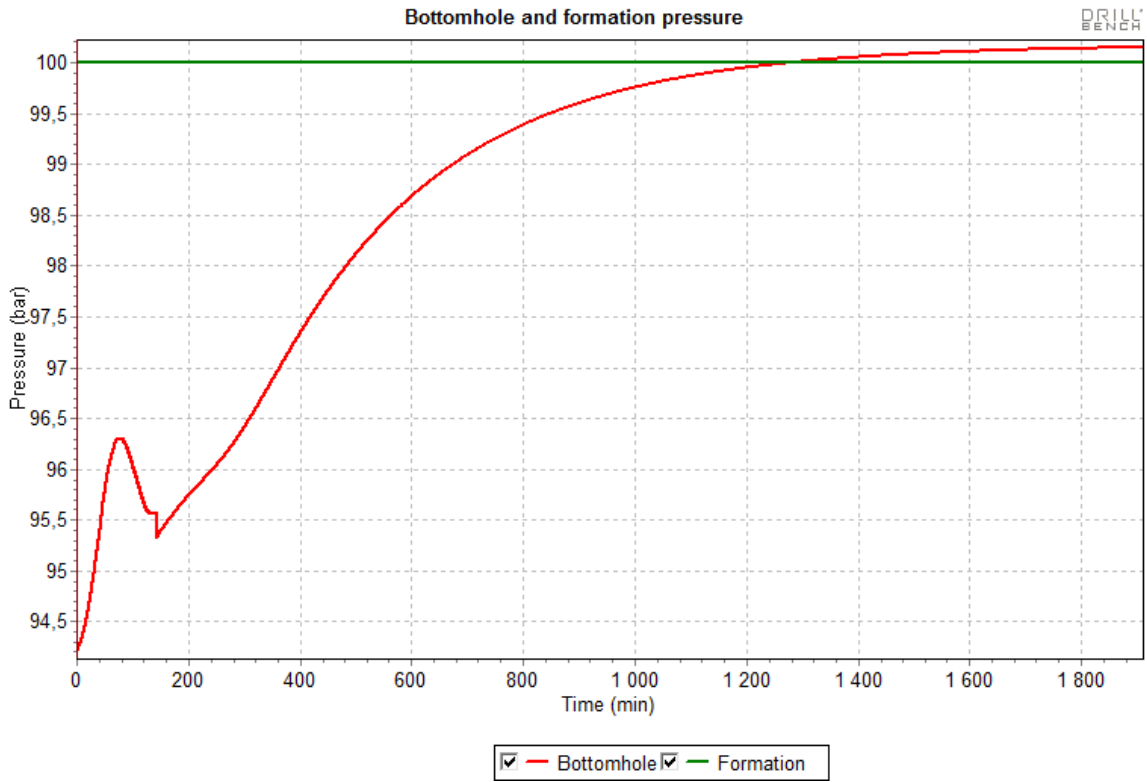

Figure 5.34 BHP - tripping heavy oil

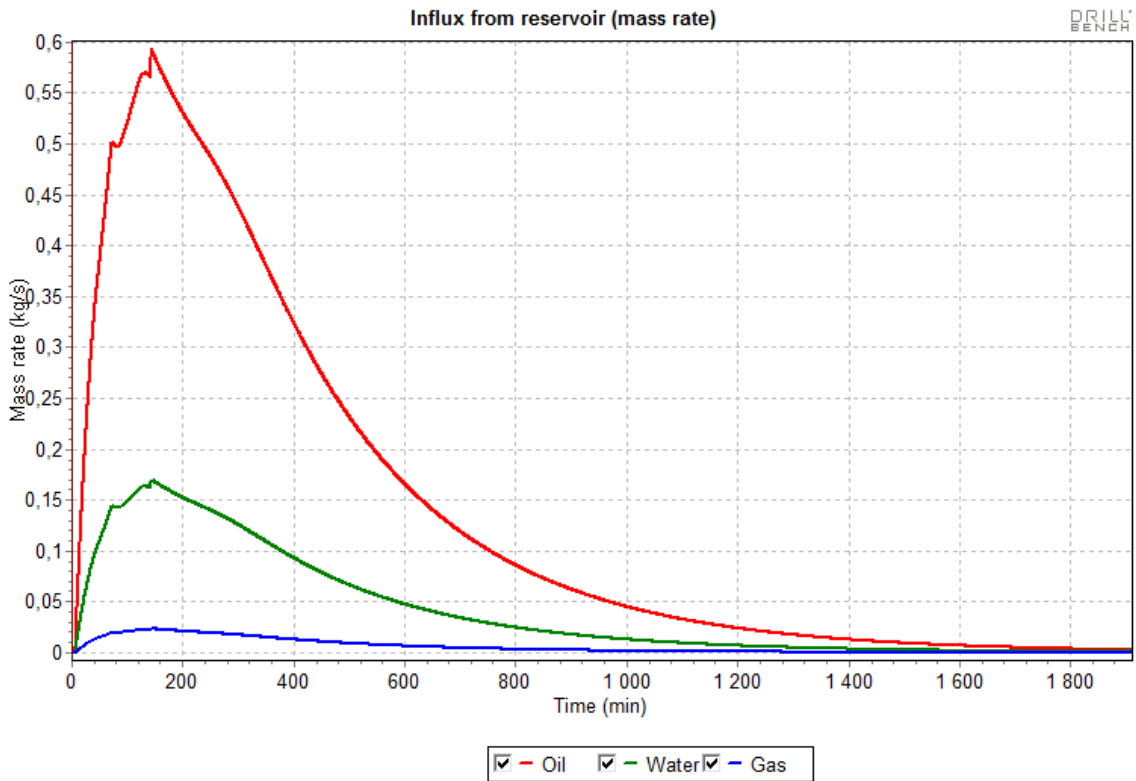

Figure 5.35 Influx - tripping heavy oil

The great difference between the two wells I have simulated is the difference in time before the well is killed. The one where separation takes place is killed much faster than the other one. We see from **Figure 5.30** that when the pumps are turned off at about 120 minutes it only takes about 220 minutes (3 hrs and 40 min) before the flow from the reservoir is stopped at about 340 minutes. When looking at the other well the time span is a lot longer. The pumps are turned off at about 140 minutes and the reservoir stops flowing after 1160 minutes (19 hrs and 20 min). To find the reason for this big discrepancy one has to investigate the two cases more thoroughly.

For the first case we have seen that we get a separation of fluids in the annulus and that this eventually leads to a fluid column in the well with 100% gas the first 200 meters, and 100% liquid the rest of the well. **Figure 5.36** shows that the flow of liquids from the well stops instantaneously when the pumps are turned off. This means that the flow in the annulus is stopping up and the liquid starts to flow down and gas up. As long as the BHP is below the formation pressure there will also be some flow into the well from the reservoir. **Figure 5.37** shows the flow of liquids from the well in the second case.

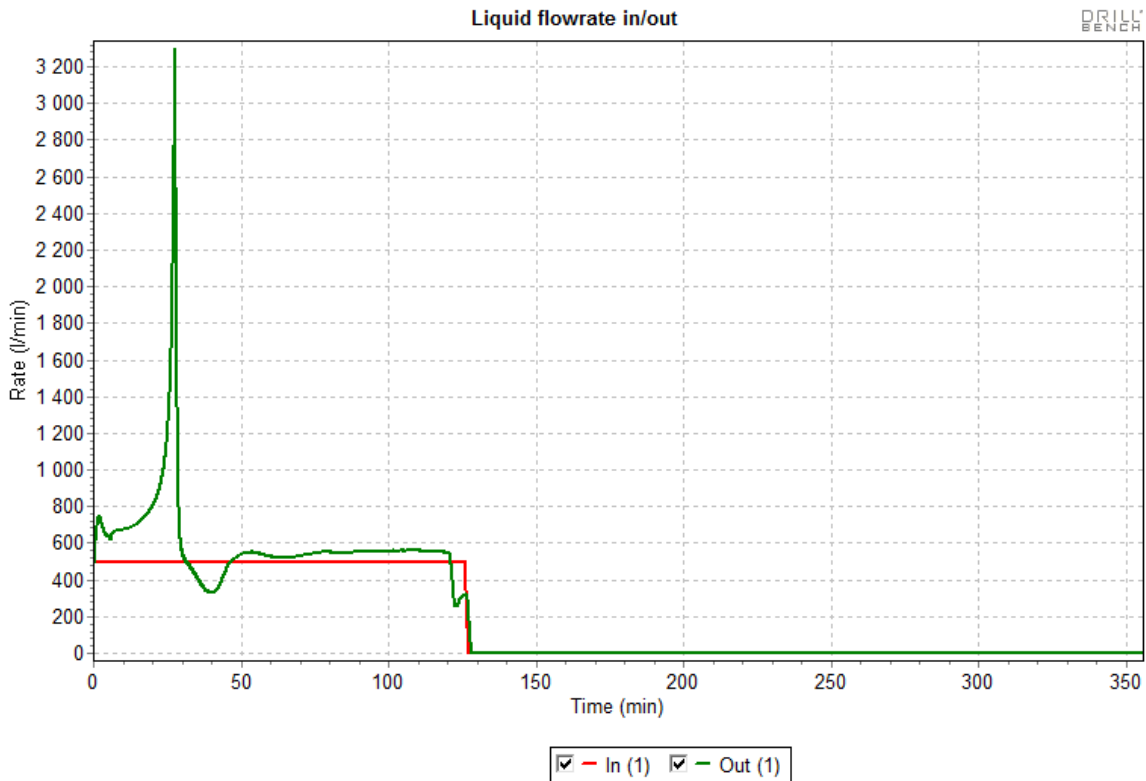

Figure 5.36 Liquid rate in/out - well with separation

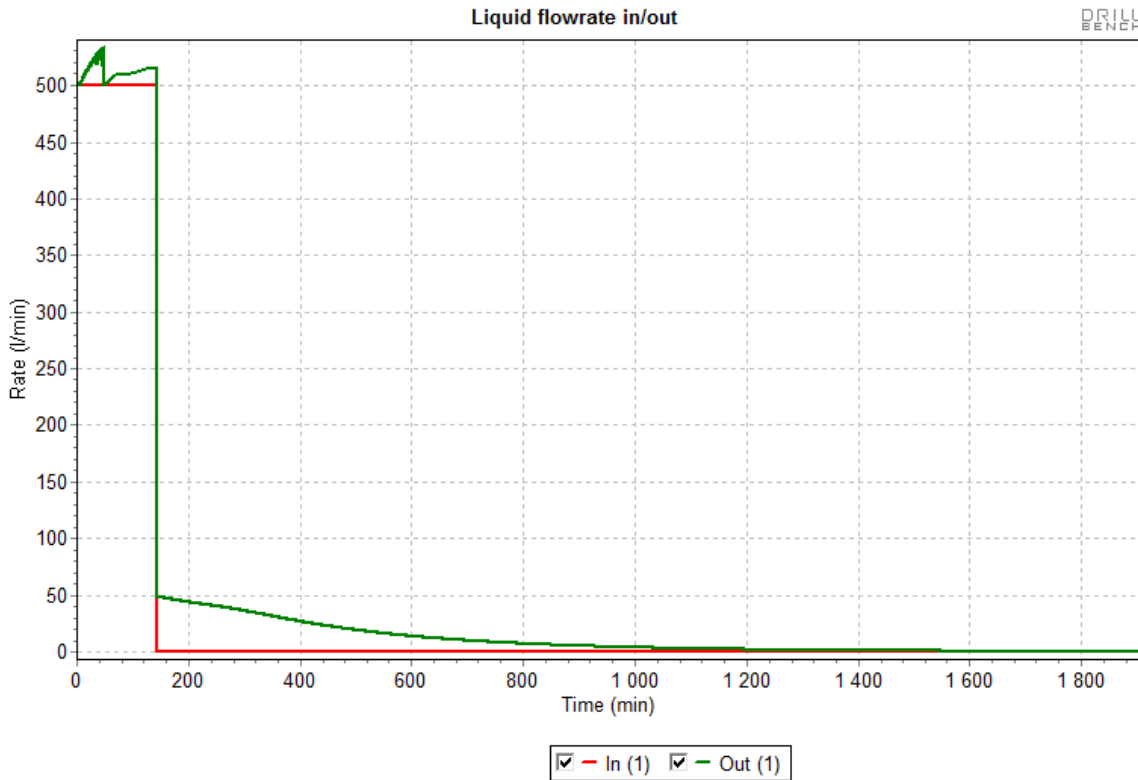

Figure 5.37 Liquid rate in/out - well with heavy oil

We see a clear difference between the two cases on the above plots. The flow from the well in the second case doesn't stop instantaneously. This is due to the fact that we don't have any separation of fluids in this case since there is no free gas in this well. The reason for the killing of the well must then be a bit different in the second case than the first one. To explain this difference we can look at **Figure 5.38** and **Figure 5.39**. **Figure 5.38** shows the plot of formation oil against depth when the well is killed for the first case.

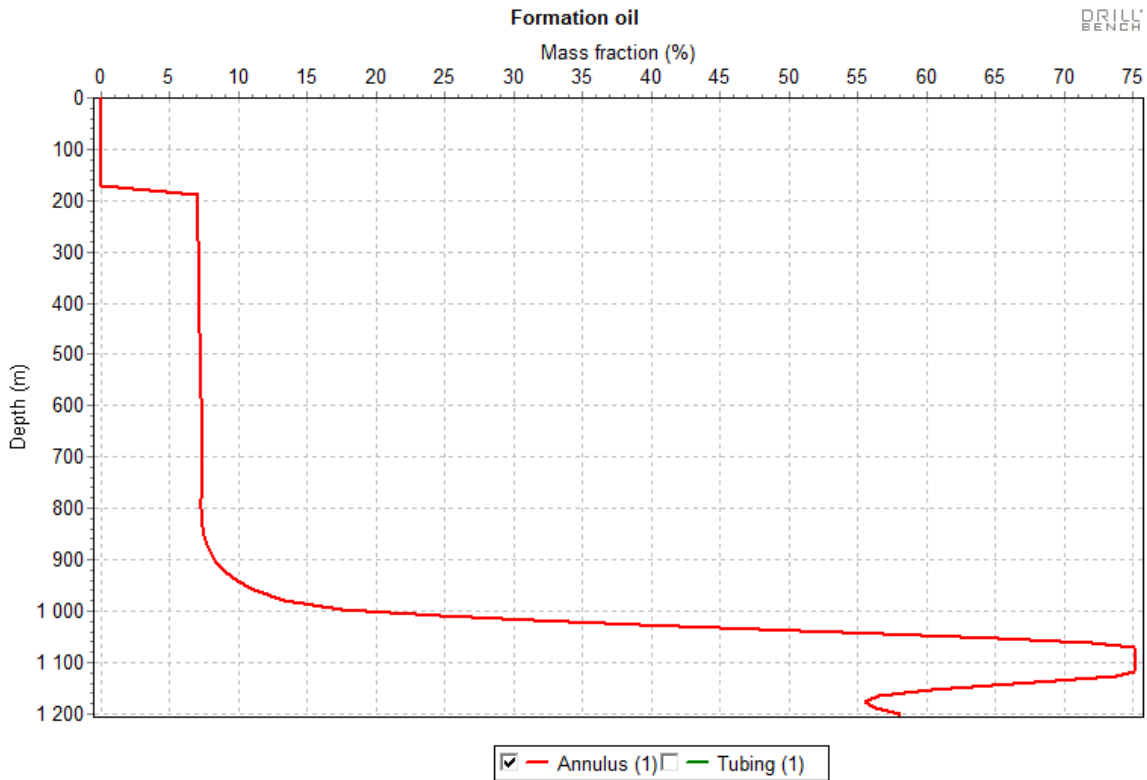

Figure 5.38 Formation oil in annulus - well with separation

Here we see that on top we have no formation oil because of the gas, but in the major part of the well from about 200 mMD to about 900 mMD we have about 7% formation oil. (And some percent formation water) The rest of this liquid column must then be made up of the liquid phase of the drilling fluid. At the bottom the formation oil (and water) have flown into the well from the reservoir and are now dominating the liquid column there. If we take a look at **Figure 5.39** which shows the same plot for the second case we see a bit different situation.

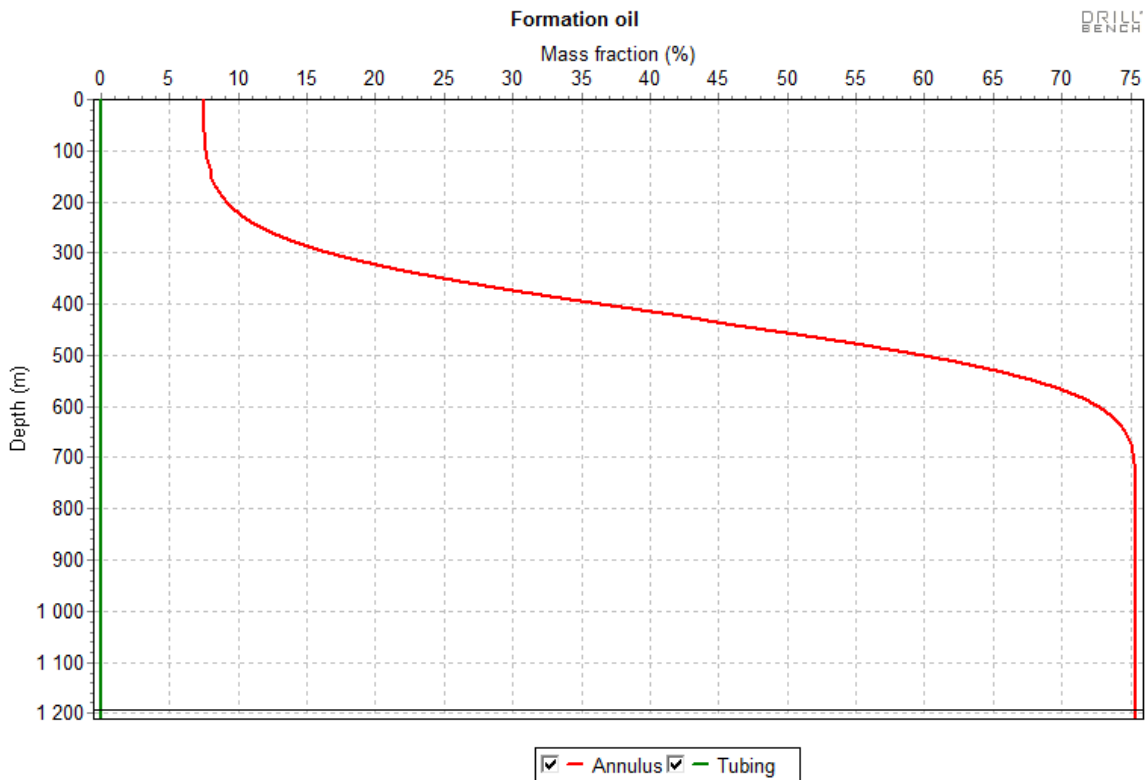

Figure 5.39 Formation oil in annulus - well with heavy oil

Here we see that the reservoir fluids dominate a bigger part of the well, and only in the top part the drilling fluid is dominating. The killing mechanism here is then not separation, but the fact that the reservoir pressure is not strong enough to push the heavy oil all the way out of the well. The reservoir flow is stopped by the weight of the produced liquid column.

5.3.2. Conclusion

To tie up the loose ends we can say that the main difference between the two cases of well killing during tripping is that in case one the well is killed because the separation creates an uneven density distribution which causes a too heavy fluid column in the well, in case two the well is killed because heavy liquid flows from the reservoir into the well until the weight of the liquid column exceeds the reservoir pressure.

The consequence of the two cases above, and all scenarios in between as long as the well is under pressured, is that the well is killed after a shorter or longer time period. This in itself is not very critical since the BHP is just stabilizing at the formation pressure. Actually this makes the tripping of the well easier since there is no flow coming from the well and the rotating control device can thus be open and tripping performed in a conventional way without the use of e.g. a snubbing unit. (Graham, 2011) The problems start when you have finished the tripping and want to start drilling again. It can then be difficult to regain the underbalanced conditions you had before without causing a significant overbalanced situation in the well. This is of course the exact thing one tries to avoid during an underbalanced operation since it can cause significant

reservoir damage. For the well with the separation problem the consequences will be in the same category as mentioned in relation with the connection issues: A pressure spike when starting the circulation again. **Figure 5.40** illustrates this problem. The reservoir liquid which has been accumulating in the wellbore during the tripping must be circulated out before the pre-trip GLR again can be established and a stable underbalanced BHP regained.

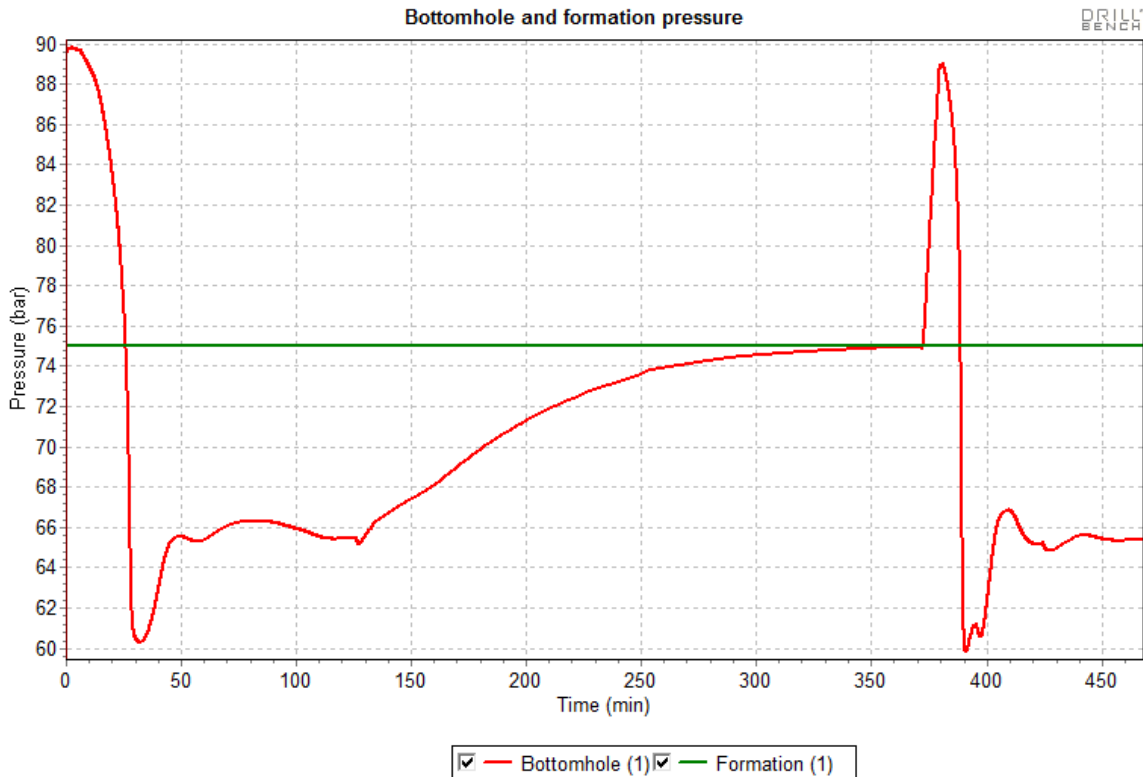

Figure 5.40 BHP - well with separation - starting circulation after tripping

We see that a pressure spike with a top of nearly 90 bar induces an overbalanced situation for nearly 20 minutes in the well. 90 bar is 15 bar over the formation pressure and is a quite severe overbalance. This could be enough to cause serious reservoir damage which can reduce the benefits of the underbalanced operation significantly. For the well in case two one will also experience an overbalanced pressure spike due to the friction pressure that is being added to the BHP when the pumps are turned back on. This spike however, will be much smaller compared to the one for case number one. **Figure 5.41** depicts the regaining of circulation for case two.

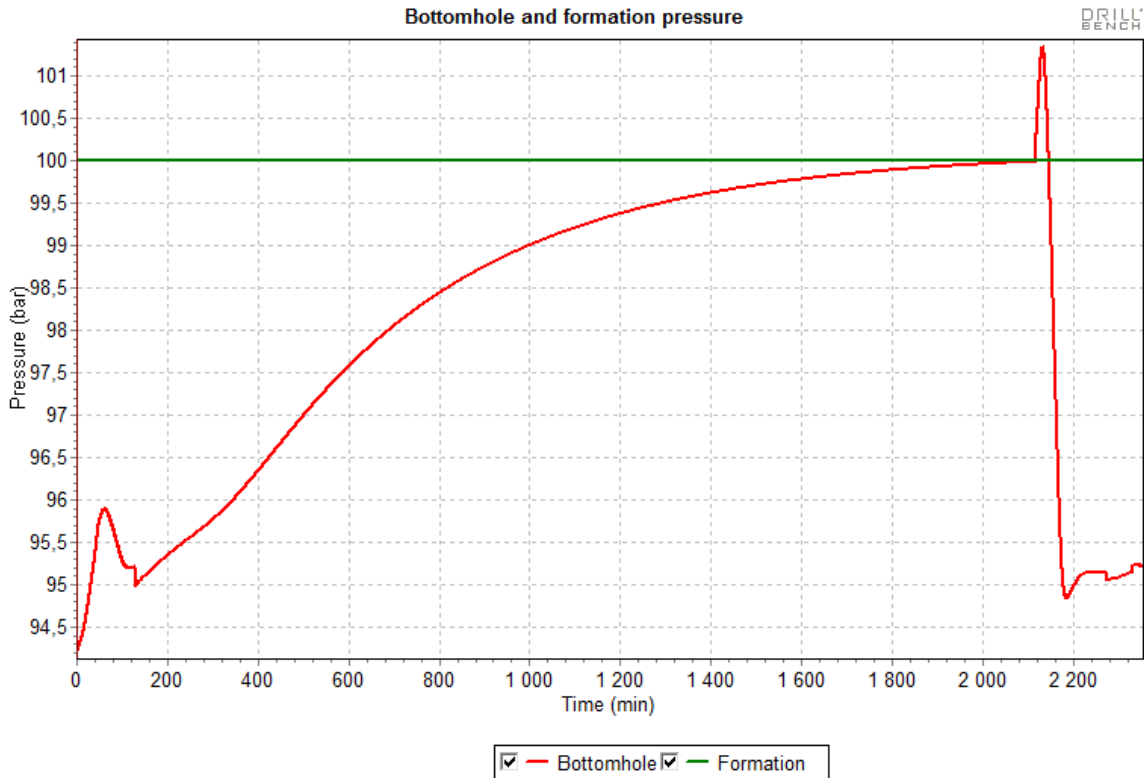

Figure 5.41 BHP - well with heavy oil - starting circulation after tripping

We see here that the pressure spike only has a magnitude of 1,3 bar above the formation pressure. The duration however, is about 30 minutes. Even though this is longer than for case one the low magnitude of the spike probably makes this situation less damaging for the reservoir than the one in the case with separation. From the analysis of the two cases one can draw the conclusion that killing due to separation both happens faster and will be more damaging to the reservoir when circulation is restarted.

To prevent the killing of a well during tripping is possible if one make use of one of the measures mentioned in the chapter about connections: The parasite gas injection method. This method allows you to maintain circulation all the time through the tripping procedure. Instead of being injected through the drill pipe the gas is injected through a parasite string or a concentric casing. The injected gas lowers the density of the produced fluids from the reservoir which makes the reservoir pressure sufficient to transport the fluids to surface during the whole tripping period. **Figure 5.42** shows how the BHP is kept relatively stable throughout the tripping period.

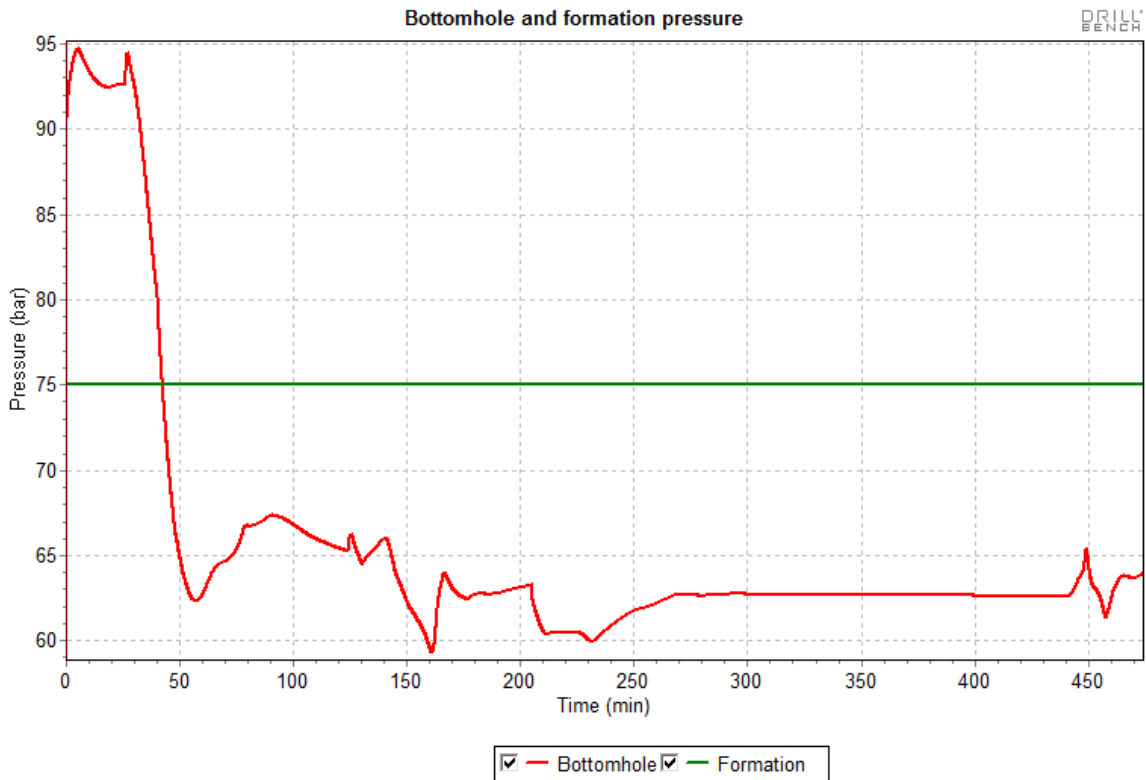

Figure 5.42 BHP parasite gas injection

We see here that we don't get the rise in BHP due to separation or a too heavy liquid column as in the two cases described above, and that the BHP is very stable. Also when the circulation is started again we only see a small alternation in the BHP, and no great spike, before it settles at a stable level again. The drawback with this method is as mentioned in the connection chapter that it is not always suitable due to the modifications needed to be made to the wellbore geometry.

In the two example cases I used the standpipe gas injection method. When you use this method it is no way to maintain circulation in the well during the tripping operation, and thus there really is no method to prevent the well from killing itself eventually. It is only a matter of time before it happens.

6. Narrow pressure window

In normal drilling the term narrow pressure window refers to a small difference between the pore pressure and the fracture pressure, i.e. a small difference between a kick and a lost circulation situation. In underbalanced drilling this term can be used a bit differently. Here the small window can be between collapse pressure and the pore pressure of the formation. In this chapter I will discuss this issue and give examples of what can happen when drilling inside a narrow pressure window.

In underbalanced drilling you always want to keep the BHP below the pore pressure to avoid formation damage. The opposite border, the formation collapse pressure, you want to keep the BHP above. If the BHP drops below the collapse pressure, it can cause borehole stability problems because pieces of formation is breaking up and falling into your well. This can lead to a stuck pipe situation with all the problems connected with that.

6.1. Pump failure

An interesting case in connection with the drilling through narrow pressure windows is that the friction pressure and the back pressure can be crucial to keep the BHP above the collapse pressure. A problem with the pumps causing an unexpected shutdown of the circulation in the hole can then lead to a pressure drop in the well that causes the BHP to go below the collapse pressure. The only tool you have at your disposal to prevent the BHP from dropping is the choke. Fast and correct action will be needed if such a pump failure situation should occur. **Figure 6.1** shows an example of a situation where the BHP drops due to a sudden pump failure.

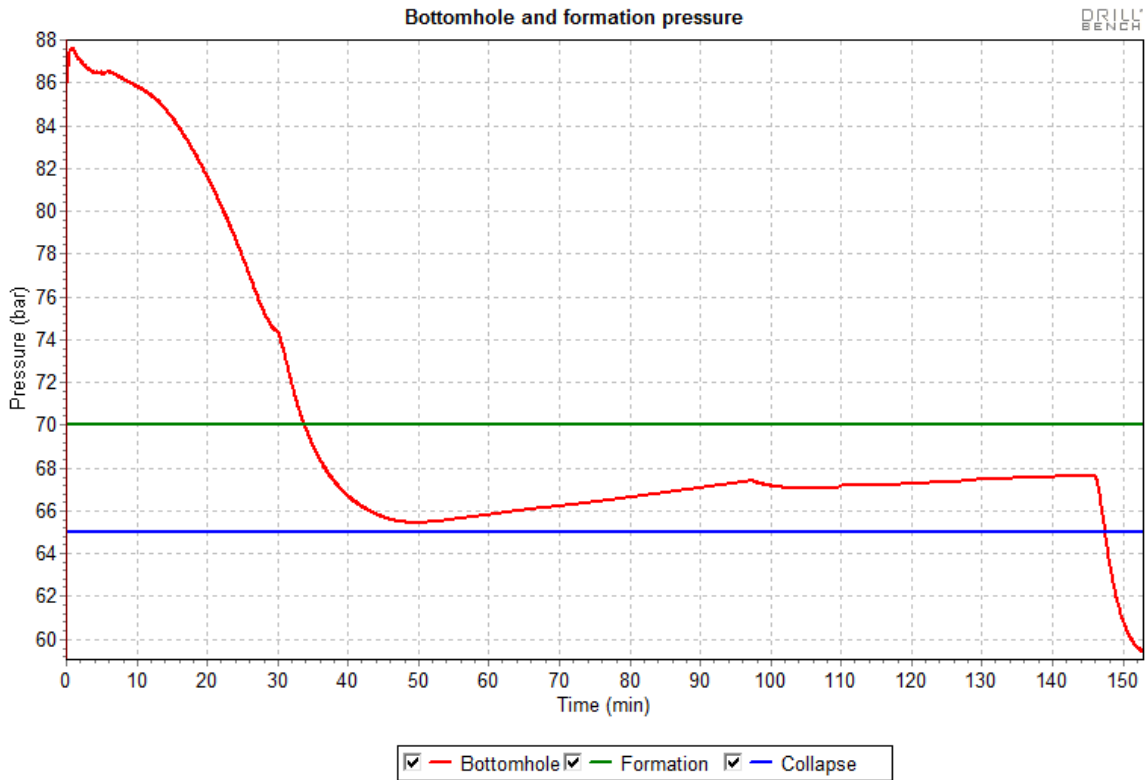

Figure 6.1 BHP - narrow pressure window - pump failure

The drilling operation in this example is dealing with a collapse pressure of 65 bar and a pore pressure of 70 bar. The drilling starts at about 50 minutes and continues without any problems until about 146 minutes. The time before the drilling starts (first 50 min) is used to circulate gas into the well and by that obtaining the desired underbalanced BHP. Only small adjustments with the choke are being made. Then the pumps are failing and the BHP drops instantly. It only takes about 1,5 minutes before the BHP crosses the collapse pressure border. This shows how fast you can get into trouble if the equipment is not being in order. The question then becomes whether or not it is possible to handle a situation like this with the help of the choke. **Figure 6.2** shows the drilling of the exact same well as in **Figure 6.1** with the same pump failure, but here the choke is used to prevent the BHP from going below the collapse pressure limit.

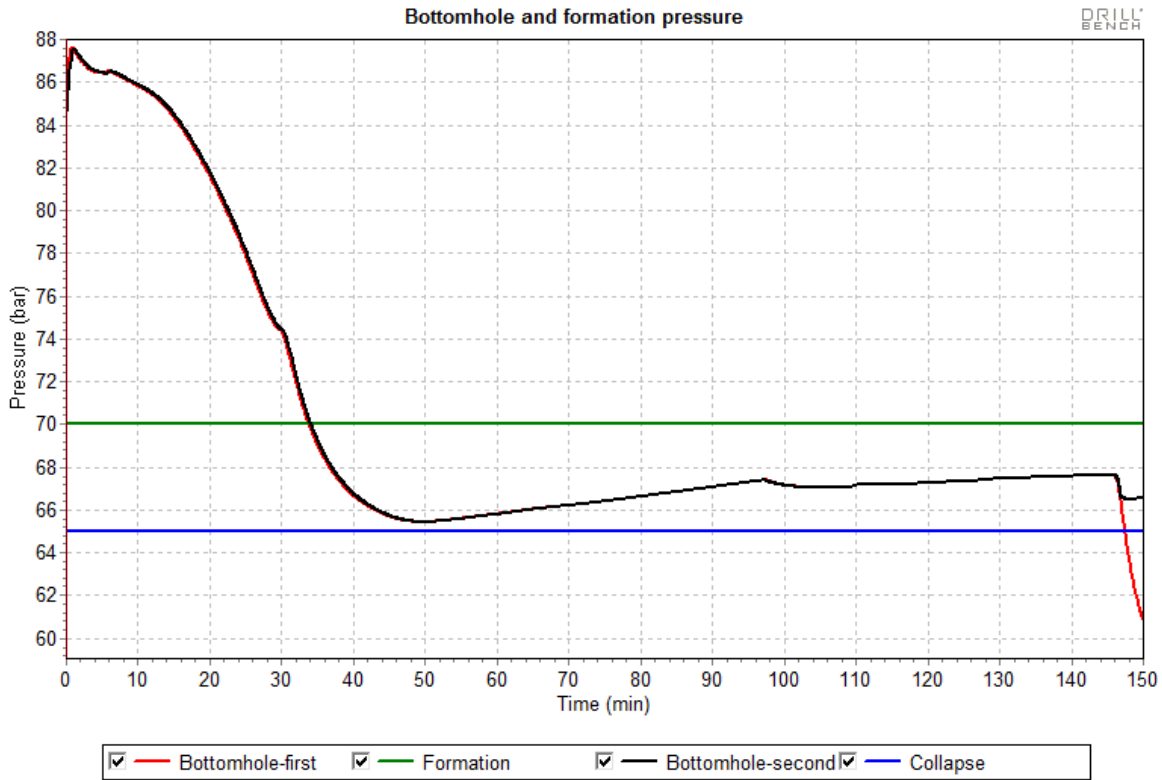

Figure 6.2 BHP - narrow pressure window - mitigating pump failure

When simulating the use of the choke I waited for one minute after the pumps were shut down then started to close choke in the steps shown in **Figure 6.3**. A pump failure is normally detected before one minute is passed (Godhavn, 2012), but for illustrating a “worst case” the one minute time period is appropriate.

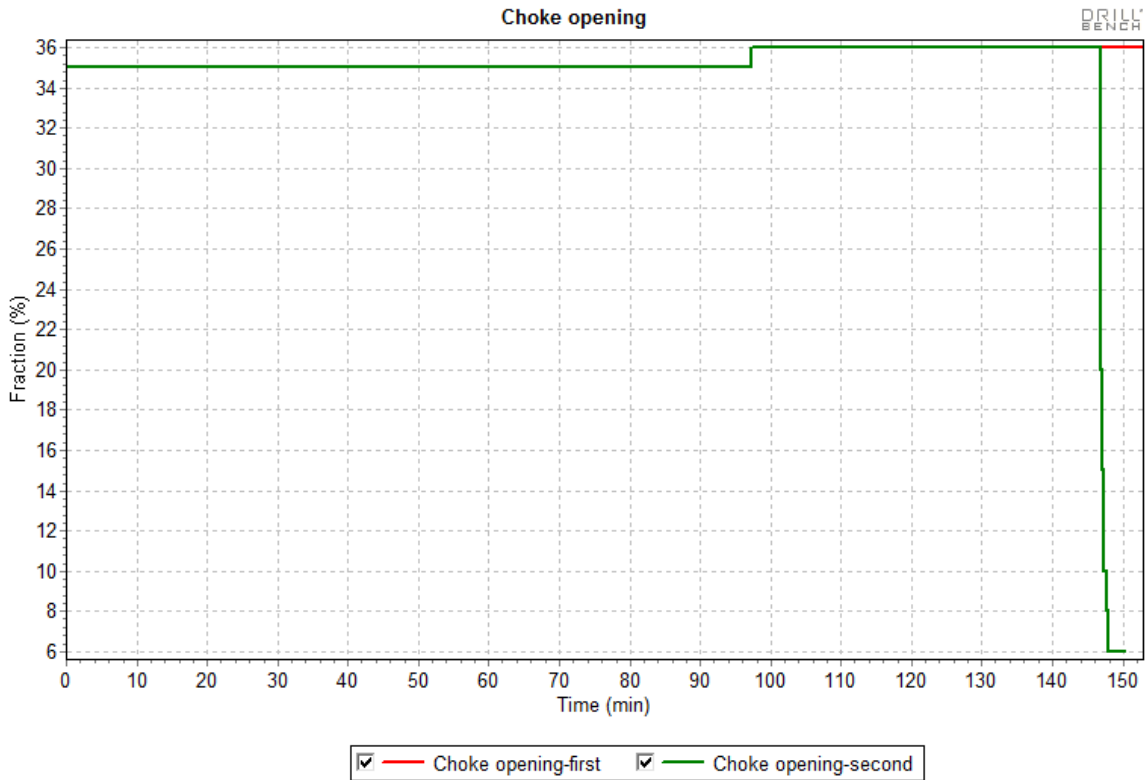

Figure 6.3 Choke opening - mitigating pump failure

For the one minute time period to be sufficient the operation needs to be closely monitored at all times and the crew trained to deal with unexpected situations. In the preparation for the operation worst case scenarios like the one in the example should be simulated, and procedures to handle it must be established.

6.2. UBD vs. MPD

Some formations have problems with small differences between the formation pressure, both between the fracture and pore pressure, and the pore and collapse pressure. Feil! Fant ikke referansebilden. illustrates how such a situation can look. With symbols the relation between the formation stresses can be shown like this.

$$p_{collapse} < p_{pore} < p_{fracture} \tag{6.1}$$

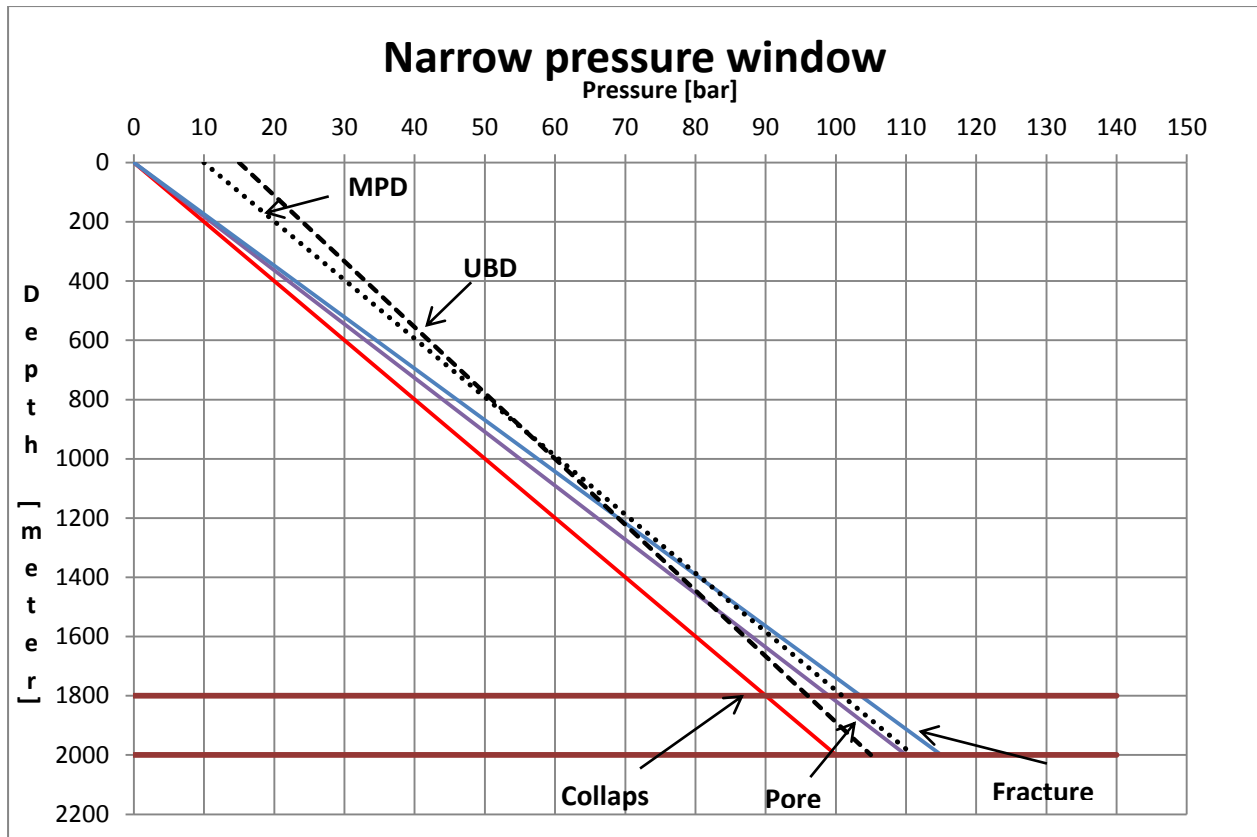

Figure 6.4 Narrow pressure window-illustration

We see here small differences between the collapse, pore and fracture pressure, and how an MPD or UBD drilling method would look if used in this pressure regime. An interesting question then becomes which drilling method one should use. Normal overbalanced drilling is ruled out since it will take you to close to the fracture pressure. The choice then stands between a near pore pressure MPD system, or a near pore pressure UBD system. The formation drilled is the key here. If the formation drilled is a low permeability zone where formation damage would influence the productivity significantly UBD would most likely be the preferred method since it doesn't reduce the productivity. If it is a high permeability formation you can achieve very good results with MPD and a well-designed mud system which causes little damage on the reservoir. A UBD system would probably achieve a better result with respect to the formation damage and productivity part, but if the formation is very productive the MPD system may be a better solution after all since it is most likely the less expensive solution and the formation damage will be little. If the formation doesn't give a clear answer to which method that should be used the determining factor should be which pressure window is the narrowest. After all the most important thing when drilling through narrow pressure windows is that the drilling is carried out with as little problems as possible and that planned depth is reached.

7. Unexpected high pressure zone

Drilling into an unexpected high pressure or high permeability zone can cause a well control situation in underbalanced drilling. Even though underbalanced operations normally are carried out in formations that have been drilled before, it is possible that some reservoir pockets have been undetected. In this chapter I will look into examples of what can happen during a situation like this and what actions that must be taken to get the situation under control.

Below I have stated the definition of a well control situation in underbalanced drilling.

The definition of a well control situation in underbalanced drilling is that parameters like pressure, flow rate or temperature are outside the design envelope for the topside equipment used in the operation. (Ramalho and Davidson, 2006)

Mathematically it can be illustrated the following way:

$$q_{gas} > q_{gas-max,separator} \quad (7.1)$$

$$q_{liquid} > q_{liquid-max,separator} \quad (7.2)$$

$$p_{surface} > p_{max,choke} \quad (7.3)$$

$$t_{surface} > t_{max,separator} \quad (7.4)$$

To avoid a well control situation it is important to monitor the flow of fluids from the well, which is the most common indicator of the hitting of a different pressure zone. Other parameters which can indicate this is increased choke pressure or change in BHP without any change in surface parameters.

To deal with a sudden increase in pressure and reservoir influx you can use the liquid rate, gas injection rate, choke or a combination of these three parameters. **Figure 7.1** shows a well control matrix that can be used as a guideline when dealing with increased pressures and influxes. The borders of the matrix needs to be specified for each operation, but the methods are general.

		Wellhead Flowing Pressure (unit)			
		Range 1 (Min ₁ - Max ₁)	Range 2 (Max ₁ - Max ₂)	Range 3 (Max ₂ - Max ₃)	> Max ₃
SURFACE FLOW RATES (unit/day)	Range 1 (0 - Max ₁)	Optimum	Adjust system to decrease WHP: · Increase liquid injection rate or · Decrease the gas injection rate	Pick-up off bottom, stop rotation: · Circulate with increasing liquid rate · Decrease the gas injection rate and · Monitor well parameters until stabilized	Shut-in well with BOP's
	Range 2 (Max ₁ - Max ₂)	Adjust system to increase BHP: · Increase liquid injection rate · Decrease the gas injection rate · Increase the surface back-pressure	Stop drilling, pick-up off bottom: · Circulate and work drill string · Increase liquid injection rate and · Decrease the gas injection rate	Pick-up off bottom, stop rotation: · Increase liquid injection rate and · Decrease the gas injection rate · Increase the surface back-pressure	Shut-in well with BOP's
	Range 3 (Max ₂ - Max ₃)	Stop drilling, pick-up off bottom: · Increase liquid injection rate and · Decrease the gas injection rate · Increase the surface back-pressure	Stop drilling, pick-up off bottom: · Circulate and work drill string and · Increase the surface back-pressure · Monitor well parameters until stabilized	Pick-up off bottom, stop rotation: · Circulate with higher density mud and adjust the gas injection rate · Monitor well parameters until stabilized	Shut-in well with BOP's
	> Max ₃	Shut-in well with BOP's	Shut-in well with BOP's	Shut-in well with BOP's	Shut-in well with BOP's

Figure 7.1 Well control matrix (Ramalho and Davidson, 2006)

I have made an example of a situation that can cause a well control situation, or at least call for some action regarding the stabilization of the BHP. I have simulated the drilling of a depleted reservoir which needs gasified drilling mud to achieve a sufficient underbalanced BHP. After drilling for some time the bit hits an un-depleted part of the reservoir and the influx from the formation increases significantly. As an equipment limitation I have used data from the MI SWACO Mud/Gas Separator (MI SWACO, 1998). The liquid capacity of this separator is 1500 gpm or approximately 5700 lpm, whilst the gas capacity is 17,5 MMscf/day or approximately 496 000 Sm³/day. **Figure 7.2, Figure 7.3, Figure 7.4 and Figure 7.5** shows the BHP, influx from the formation, flow of liquids from the well and flow of gas from the well if nothing is being done to counteract the changes caused by the high pressure zone.

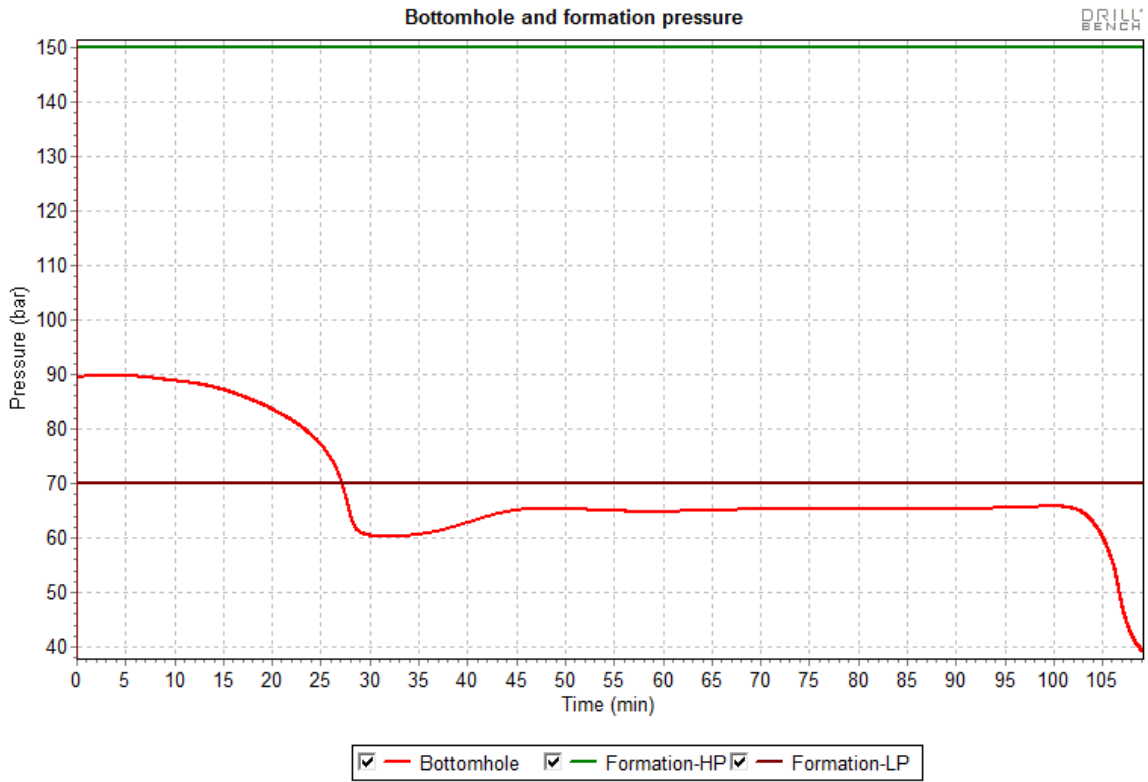

Figure 7.2 BHP - drilling into high pressure zone

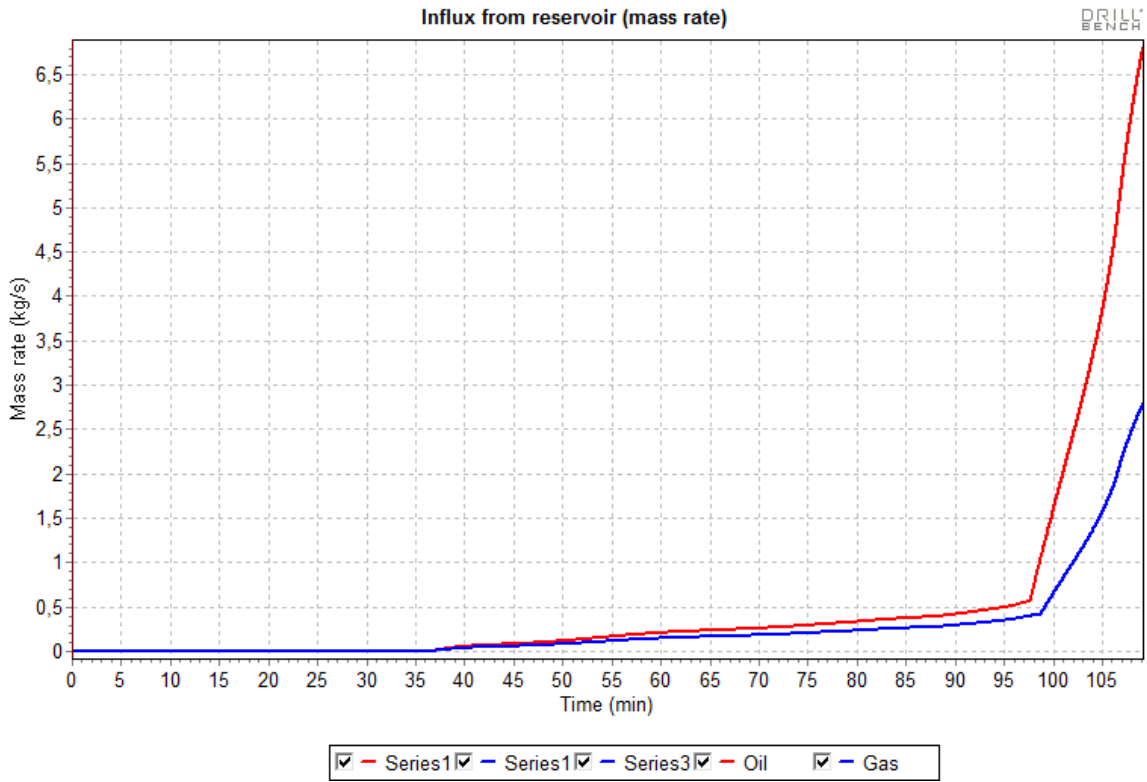

Figure 7.3 Influx - drilling into high pressure zone

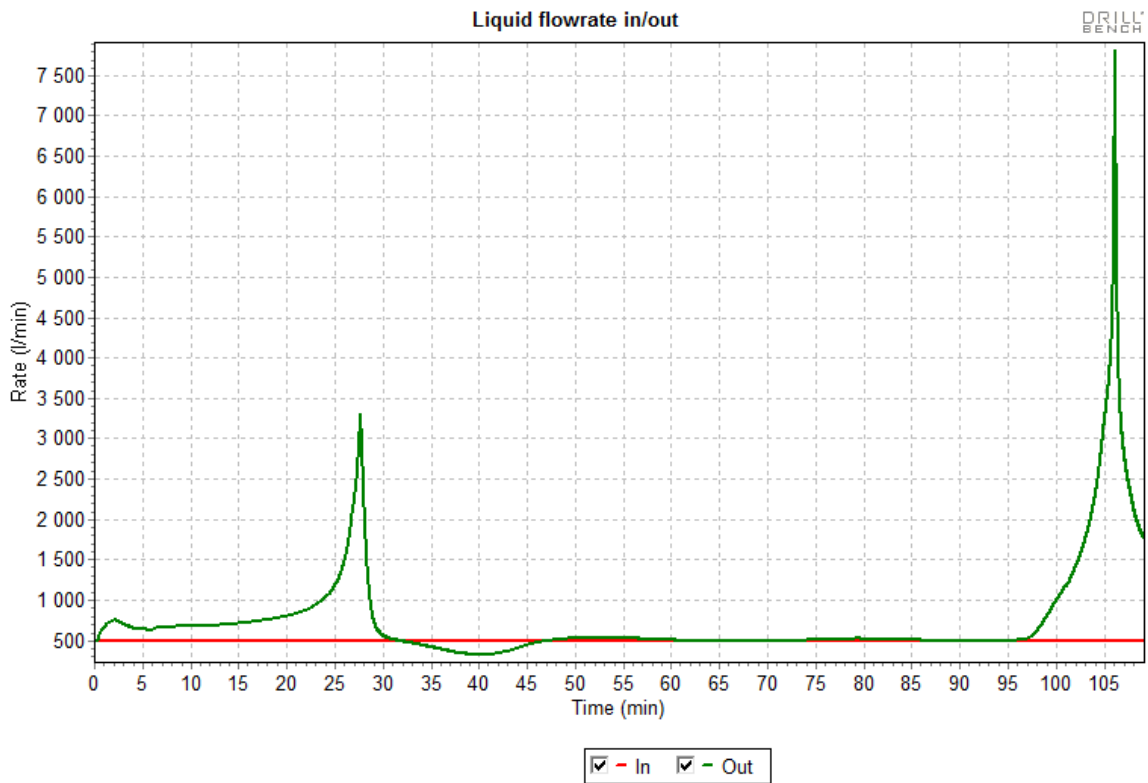

Figure 7.4 Liquid rate in/out - drilling into high pressure zone

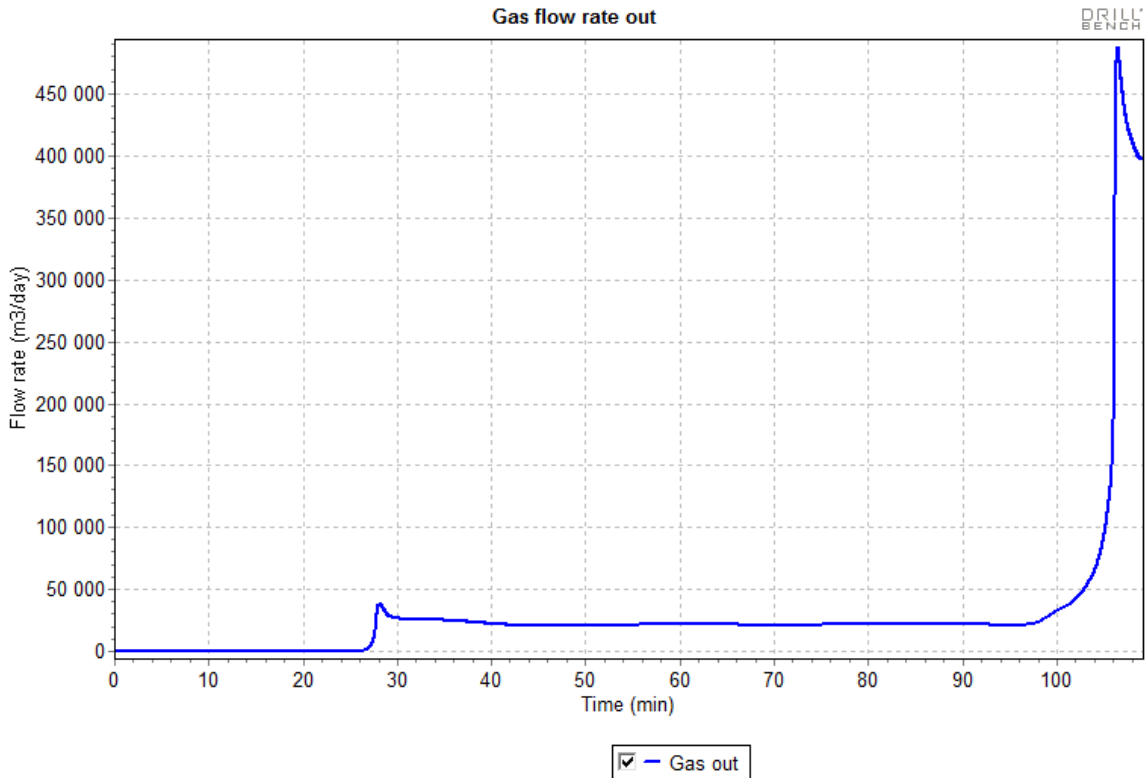

Figure 7.5 Gas rate out - drilling into high pressure zone

We see on **Figure 7.4** that the flow of liquids from the well is exceeding the capacity limit of the separator, only for a short time period, but the conclusion must be that this is not a favorable situation. On **Figure 7.5** we also see that the gas rate is very close to the limit of the separator. This is further supported by **Figure 7.2** which shows a significant drop in the BHP due to the increased influx of gas into the well, and thus the lowering of the density of the fluid column.

If you encounter a situation like the one described above an undesirable situation can manifest itself. If you increase the BHP you risk that the under pressured section of the well you already have drilled can be significantly damaged due to invasion of drilling fluid when the pressure in the well is increased to counteract the high influx experienced at the bottom. If you don't increase the BHP you can risk the safety of the rig by exceeding the pressure and flow limitations of your equipment. Of course safety always comes first, but if it is possible, without violating any safety rules, one should try to avoid damage of the low pressure part of the well while dealing with the high pressure at the bottom. Otherwise the whole underbalanced operation may be in vain, or at least the value of it can be significantly reduced. This may not happen at once, but if you try to drill through the high pressure zone and it appears to be of some length, the influx will get bigger and bigger as the well gets longer. This can force you to after some time to increase the BHP so much, to be able to control the flow from the well, that the pressure in the well in the under pressured part of it exceeds the pore pressure at that location. **Figure 7.6** shows a situation where it is tried to drill through the high pressure zone encountered in the example above, and at the same time try to keep the pressure in the low pressure part of the well below its formation

pressure. We see that the gas rate out of the well is exceeding the limit of 496 000 m³/day after a while when drilling ahead into the high pressure zone.

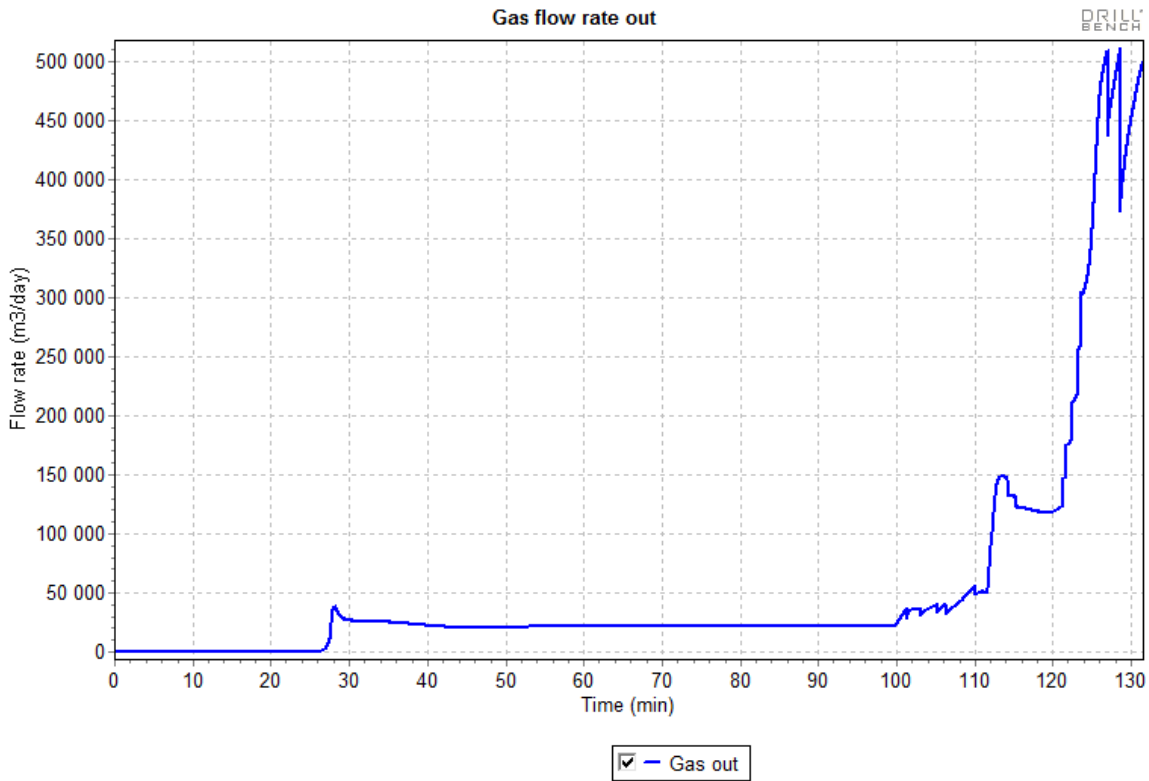

Figure 7.6 Gas rate out - drilling further into high pressure zone

It was tried to counteract the gas flow by closing the choke. This is shown on **Figure 7.6** by the drops in gas flow from the well. This is however only temporary drops and we see that the rate starts to increase again almost instantaneously. If the drilling had continued further the rate would have continued to increase. The liquid flow from the well is not exceeding any limits due to the closing of the choke so the gas flow is the limiting factor here. The consequence of this act is depicted in **Figure 7.7** which shows that the BHP exceeds the depleted zone formation pressure after drilling ahead for some time. We can also observe that we don't get the sudden drop in the BHP as we see in **Figure 7.2** since the choke is being closed to counteract the high influx. This doesn't necessarily mean that the pressure in the depleted part of the well, which is higher up, has reached that level, but **Figure 7.8** shows us that the pressure at 1200 m is above 70 bar which means that all of the low pressure zone feels a well pressure above the formation pressure.

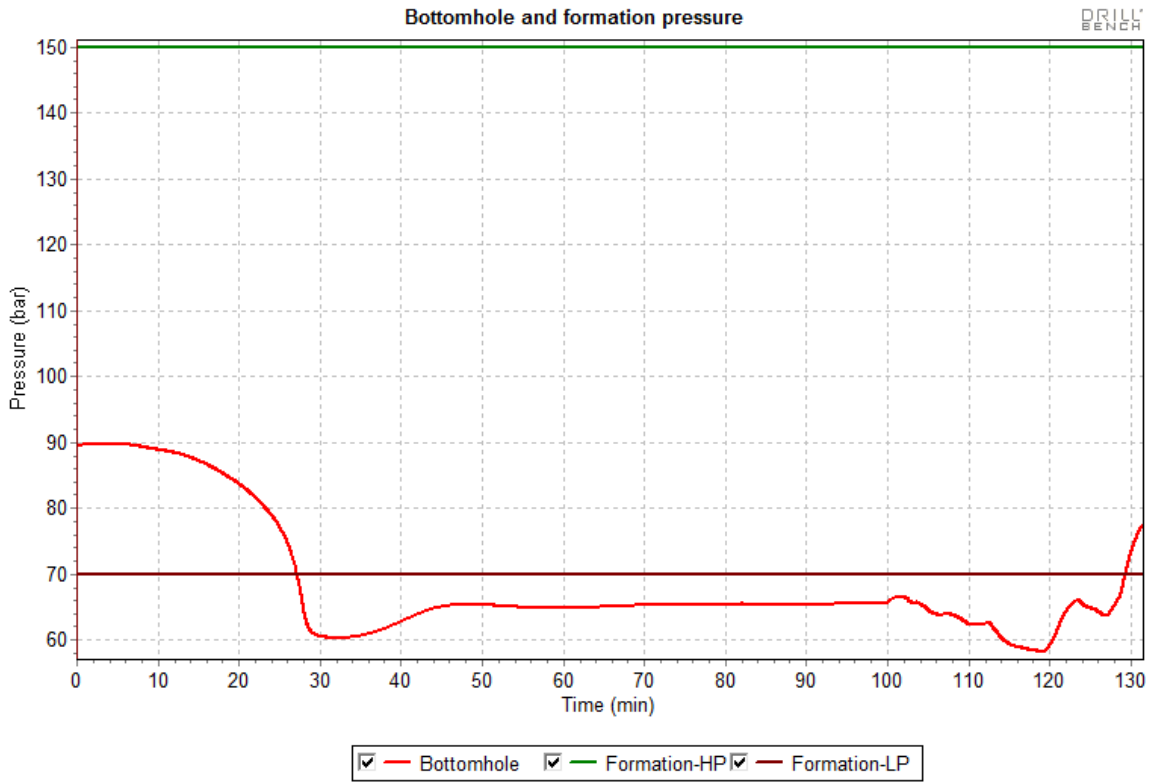

Figure 7.7 BHP -drilling further into high pressure zone

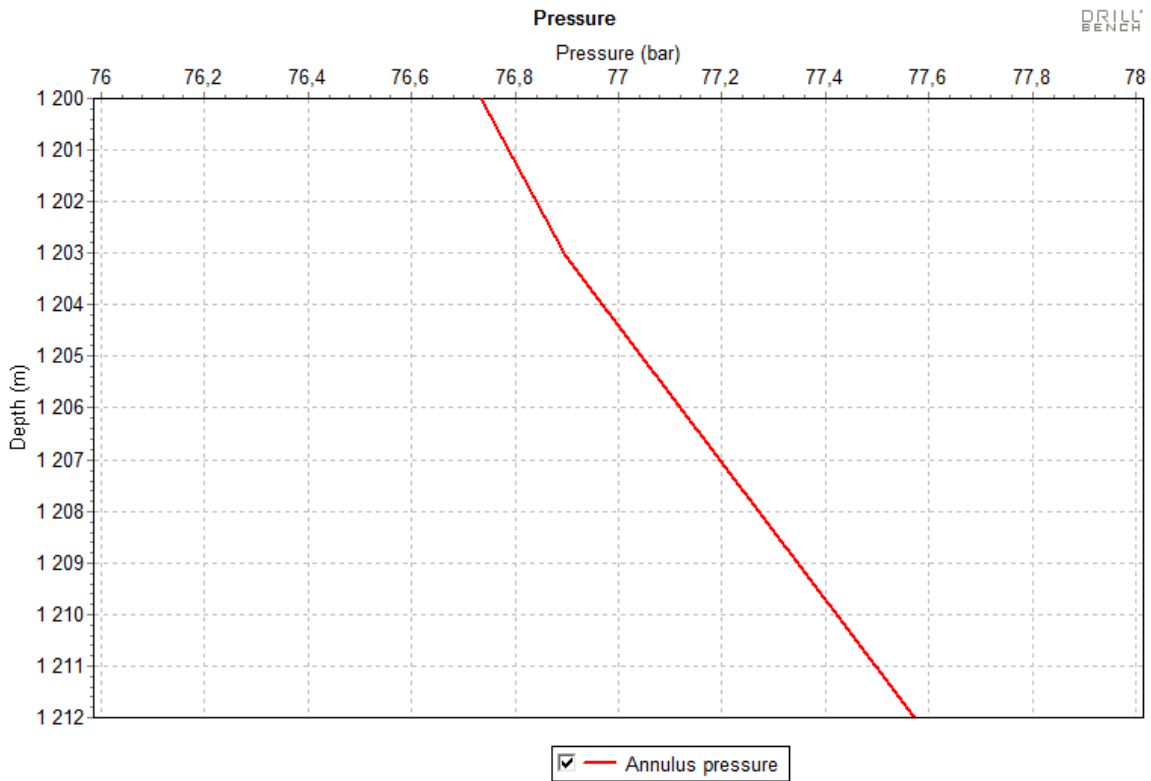

Figure 7.8 Pressure in annulus - drilling further into high pressure zone

We can conclude with that the situation depicted in the three figures above is not very favorable when it comes to the exploitation of the low pressure zone.

In the situation above the choke alone was used to try to control the influx. This is as we know not the only parameter we can change to control the BHP. A combination change of the parameters could perhaps have obtained a better result, i.e. being able to drill further into the high pressure zone before the low pressure zone experienced a too high pressure, than what was obtained in the example above. At the end of the day it is however the pressure in the well, and not how you obtain it, which decides what's going to happen at the surface and in the low pressure part of the well. The conclusion must be that drilling into an unexpected high pressure zone can cause problems regarding both capacity of the surface equipment and the risk of ruining the benefits obtained with underbalanced drilling in a low pressure part of the well. It is difficult to be 100% prepared for a situation like this, but worst case scenarios should be simulated in the planning phase and robust equipment selected so that you are able to deal with big amounts of unexpected flow.

8. Automation of BHP control

The drilling process have over the last years become more and more automated by the help of more and more sophisticated computer tools. It is then interesting to look into if this is something that can be done in underbalanced drilling also. In this chapter I will discuss if there are any possibilities for more automation in underbalanced drilling in the future. The most interesting case here will be whether it is possible with a more automated BHP control, preferably in combination with the choke.

When you drill underbalanced the goal is to keep the BHP a stable as possible around a preferred predetermined value at all times, both during drilling, connections and tripping. When drilling underbalanced the fluid system in the well is much more complex than in a normal drilling situation due to the influx from the reservoir and the mixing of gas in the drilling fluid. Issues during transient conditions like separation of fluids in the well complicate the modeling. This makes it very difficult to model the behavior of the fluids and pressures in the well in real-time. Because of this a dynamic model of the fluid system running all the time based upon PWD data, like in a MPD operation, is not yet in common use. (Graham, 2011) An automatic control of the BHP may then have to be done by the help of other tools than just a computer model.

To control the BHP very accurately, and as a step on the way towards automation, the use of an automatic choke can be a good solution. An example of such a choke would be the AUTOCHOKE provided by MI SWACO. (MI SWACO, 2010) The choke regulates the flow of fluids from the well based on a set-point pressure. If the casing pressure, i.e. the pressure at the top of the annulus, goes up in relation to the set-point pressure the choke opens a bit and more flow is let through until the pressure drops again. If the pressure drops the choke closes a bit. Since the choke is being regulated all the time it helps keeping the casing pressure, and thus the BHP, very stable not only during drilling, but also during tripping and connections. The use of this choke in itself doesn't provide an automatic control of the BHP since it needs an input pressure to determine the choke opening. This input pressure needs to be calculated by a computer model based on the parameters used in the operation and calibrated against a measured BHP value.

Because of the difficulties with real-time modeling of the hydraulics in the well it might be better to regulate the choke based on measurements of the BHP. To be able to do this one is dependent on secure measurements and transmission of these back to surface. In normal drilling results from MWD, PWD and other tools in the BHA is transmitted back to surface by pulses through the drilling mud. If the standpipe gas injection method is being used this is excluded since the compressibility of the fluid in the drill string will be too big to transmit the signals. (Graham, 2011) A possible way to overcome this problem would be to use wired drill pipes. Then you would not be dependent on an incompressible drilling fluid, and also much bigger amounts of data could be transmitted to surface in real – time. The data rates achieved with mud – pulse

telemetry lies in the range from 3 – 40 bits per second (bps) and electromagnetic telemetry ranges from 3 – 20 bps. For wired pipes the rates are about 58 000 bps. (Allen et.al., 2009) This will allow you to maintain a constant knowledge of the BHP at all times, which gives you the possibility to control the well pressure with the choke. An automation of this system would make the choke regulate constantly to keep the BHP stable. The difference between this system and the one described above is that here you regulate the choke based on the measured BHP, and there based on the pressure measured at the choke.

Another possible way to automate BHP regulation is to make use of the pump pressure. This can also be a backup solution if there becomes a problem with pressure sensors in the BHA and BHP measurements can't be carried out. The goal here will be to regulate the choke based on an estimated BHP which is calculated by the help of the pump pressure, hydrostatic pressure of fluid column in the drill string and the friction pressure in the drill pipes. By doing this you get a real time estimate of the BHP that can be used as a basis to control the choke opening. To illustrate this I have made a simplified example of how this can be done.

First I will introduce some equations that need to be used to make this example.

$$p_{BHP} = p_{pump} + p_{hydrostatic} - p_{friction} \quad (8.1)$$

$$p_{hydrostatic} = [p_{BHP} - p_{pump}]_{0-rate} \quad (8.2)$$

$$p_{friction} \propto aq^2 \quad (8.3)$$

First step in the process is to find the friction constant named a in equation (8.3). To do that, I used data from the simulation of the well illustrated in **Figure 5.26** where I used the choke to reduce the BHP fluctuations caused by separation of fluids. When the pumps were off during the second connection I found the hydrostatic pressure in the drill string by using equation (8.2). Then I used the data from the starting of the mud pump from zero to 500 lpm to make a plot of the friction pressure against rate by the use of equation (8.1). By turning equation (8.1) around you get:

$$p_{friction} = p_{pump} + p_{hydrostatic} - p_{BHP} \quad (8.4)$$

This equation is used to make the plot in **Figure 8.1** which shows the friction pressure in the drill string against the rate of liquid pumped through the string.

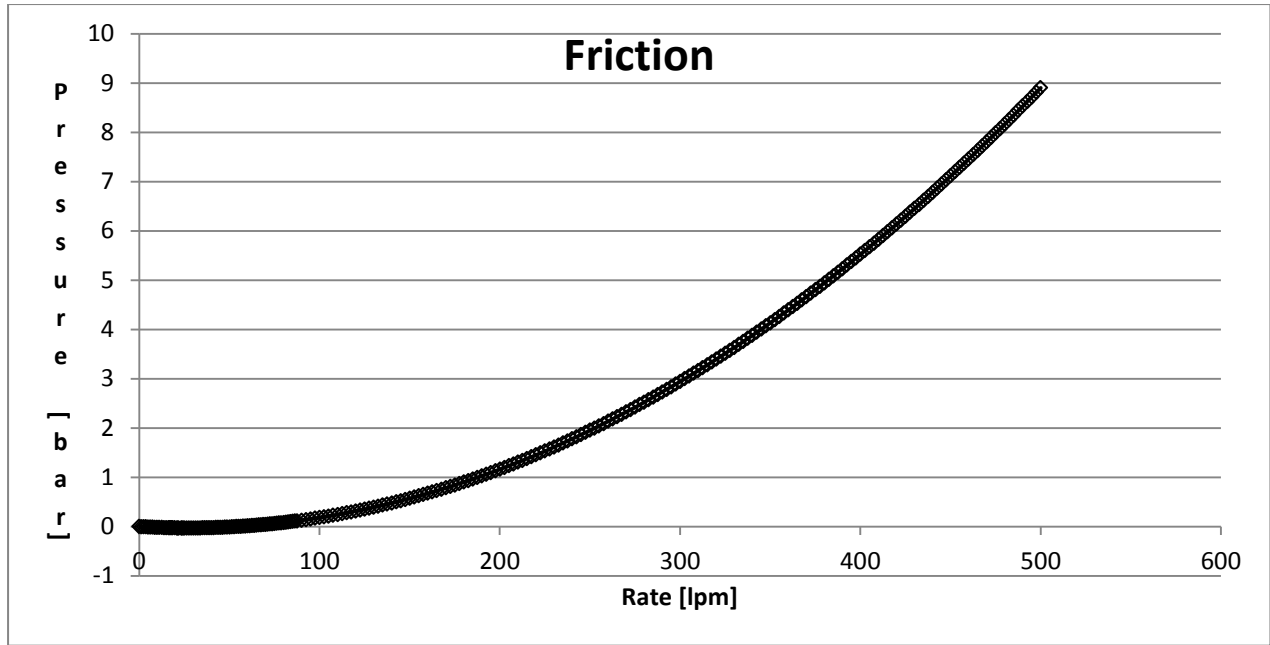

Figure 8.1 Friction pressure

We see that the friction in the drill pipes is rather small even for the max rate. The reason for this is that the well being simulated is quite short and that the flow rate of liquids pumped through the drill pipes is low. This also means that under these circumstances the starting of the pumps will have a quite small effect on the BHP since the friction pressure in the drill string is so small. Applying the trend-line function on this graph gives the slope of the curve and thus the friction constant a . We can now calculate an estimated friction pressure with equation (8.3), and then an estimated BHP with equation (8.1). Figure 8.2 shows the actual BHP and the estimated one along with the pump rate plotted against the time it takes for the pump to go from zero to 500 lpm.

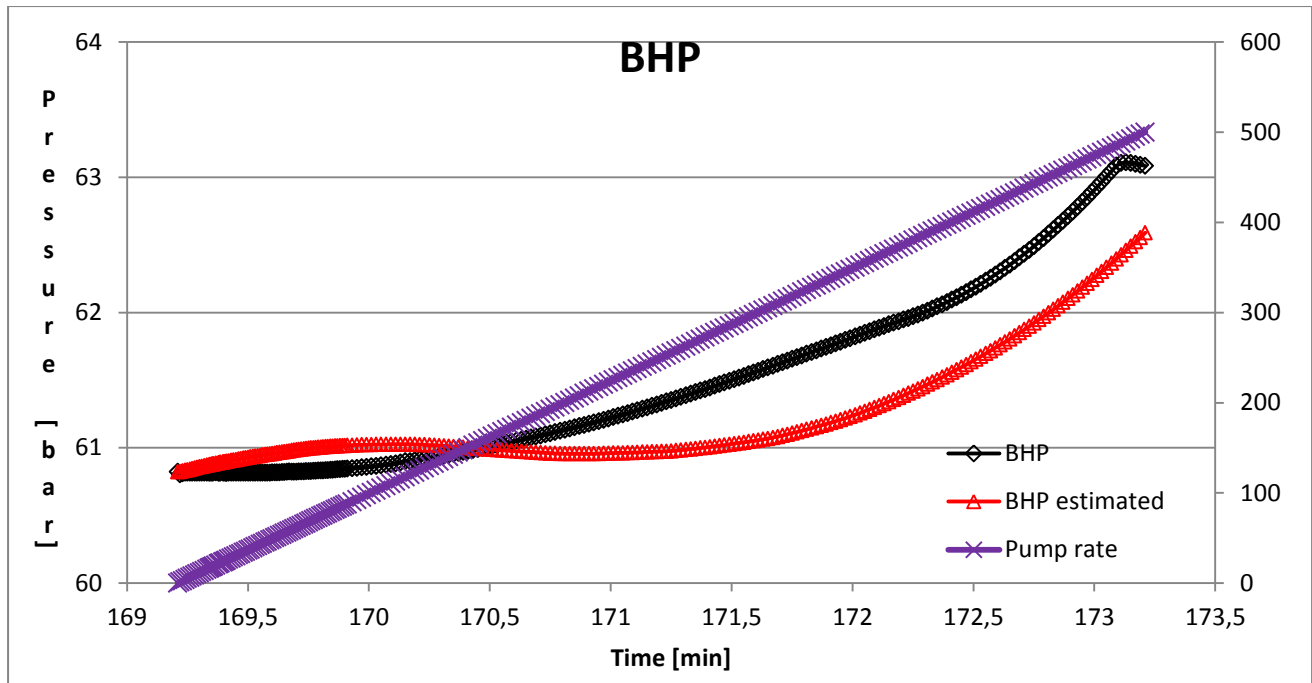

Figure 8.2 Estimated BHP

We see that the estimation is quite good for this time interval and that it would have been possible to operate based on the estimated curve.

Even though the curves in **Figure 8.2** look promising we can't say that this would work for all future operations. The estimated BHP curve is based on measured data and fitted to these in the best possible way. As the drilling goes on the friction constant a , will increase as the length of the drill string increases. To be able to do as in the example in a real operation one could estimate a based on simulations, but it would have to be calibrated against measured values from the drilling operation to become as correct as possible. Another issue is that these results are based on the use of one particular flow rate. If you for some reason would want to change the flow rate during the operation a new friction constant a may need to be determined. In other words you could not have started a drilling operation and based your choices entirely on an estimated BHP. This also makes it difficult to base an automation of the operation on this technique since you need to perform drilling to calibrate before you can base your choices on the estimated BHP.

9. Conclusion

The main goal with this thesis was to study how the bottom hole pressure can be controlled with different parameters, and investigate different scenarios that can occur during normal drilling operations. Also more specific situations like narrow pressure windows and equipment failure should be looked into. A discussion about automation of underbalanced drilling should also be included in the thesis. I have studied all the topics mentioned above and by that reached the goals I sat at the start of my work with this thesis.

The experiments done to see how changes in the three parameters liquid injection rate, gas injection rate and choke opening affect the bottom hole pressure showed me that closing the choke is not always the fastest way to change the bottom hole pressure. This is important knowledge since it will allow you act correctly if you encounter a situation where the bottom hole pressure needs to be changed fast, to e.g. compensate for an increased influx due to the entering of a high pressure zone.

Doing a connection while drilling an over pressured well doesn't offer any big problems when it comes to keeping the bottom hole pressure on a quite stable level. The reason for that is that an over pressured well is able to produce reservoir fluids and bring them to surface at all times. This means that the pressure in the well, when the pumps are off during a connection, can be adjusted by closing the choke. For an under pressured well the phenomenon of separation of fluids can cause serious problems if not dealt with properly. Significant fluctuations in the bottom hole pressure which can result in either reservoir damage or borehole stability problems may be the consequence of separation of fluids. The choke can be used to reduce the bottom hole pressure fluctuations significantly if it is regulated correctly and at the right time.

Tripping an under pressured well while using the standpipe injection method can lead to the killing of the well. This can be caused by separation of fluids in the well, or if the reservoir contains heavy oil, the well is killed when the column of reservoir fluids in the well gets so heavy that the reservoir pressure is no longer able to bring the fluids to surface. Eventually an under pressured well will be killed if circulation is stopped for a long period, and it is likely that you will not be finished with the tripping before this happens. When starting the circulation again a spike in the bottom hole pressure above the formation pressure will take place if the well has been killed during the tripping.

When drilling through narrow pressure windows it is important to monitor the operation closely and be prepared for worst-case scenarios. Training of the crew and simulations of such scenarios in beforehand will be necessary to be able to deal with them in a proper way. A pump-failure situation can cause a drop in the bottom hole pressure below the collapse pressure limit. If this is encountered, fast and correct action with the choke will help maintaining the bottom hole pressure on a stable level. When the difference between both collapse and pore pressure, and

between pore and fracture pressure is small both underbalanced drilling and managed pressure drilling can provide useful solutions. The choice must be based on reservoir type and which of the two pressure windows that are the narrowest.

Drilling into an unexpected high pressure zone can cause problems regarding both capacity of the surface equipment and the risk of ruining the benefits obtained with underbalanced drilling in a low pressure part of the well. To be prepared for a situation like this worst case scenarios should be simulated in the planning phase and robust equipment selected so that you have a safety margin if you hit an unexpected high pressure zone.

Automation of underbalanced drilling is challenging because of difficulties with modeling of multiphase fluid systems and low data transportation rates from the bottom to the surface. By using wired pipes one can get good knowledge about the bottom hole pressure at all times during drilling. This can allow you to regulate the choke properly to adjust the bottom hole pressure if necessary. Another possible method could be to use the pump pressure and a model of the friction in the drill pipes to make an estimation of the bottom hole pressure, and then regulate the choke based on this estimation.

10. Abbreviations

BHA	Bottom Hole Assembly
BHP	Bottom Hole Pressure
BOP	Blow Out Preventer
GLR	Gas-Liquid Ratio
MWD	Measurement While Drilling
OBD	Overbalanced Drilling
PWD	Pressure While Drilling
RCD	Rotating Control Device
ROP	Rate Of Penetration
UBD	Underbalanced Drilling

11. References

- Aadnoy, B., Cooper, I., Miska, S., Mitchel, R., & Payne, M. (2009). "Advanced Drilling and Well Technology". Richardson, Texas, USA: Society of Petroleum Engineers.
- Allen, S., McCartney, C., Hernandez, M., Reeves, M., Baksh, A., McFarlane, D.: "Step-Change Improvements with Wired-Pipe Telemetry" Paper SPE presented at the IADC/SPE Drilling Conference and Exhibition held in Amsterdam, The Netherlands, 17-19 March 2009
- Bennion, B.: "UBD technology offers pathway to solving complex reservoir problems" Published in "The American oil and gas reporter", February 1999
Retrieved 20.09.2011 from Weatherford Laboratories:
http://omnilabs.com/media/34818/ubd_technology_offers_pathway_to_solving_complex_reservoir_p.pdf
- Eck-Olsen, J. Vollen, E. Tønnesen, T.: "Challenges in implementing UBO technology" Paper SPE 91239 presented at SPE/IADC Underbalanced Technology Conference and Exhibition, 11-12 October 2004, Houston, Texas
- Eck-Olsen, J. (2003). "IADC Rigpass for Statoil, Underbalanced Drilling Orientation". Bergen, Norway: Statoil.
- Eck-Olsen, J. (2010). "Underbalanced Applications: Planning and design". Lecture TPG4215 High Deviation Drilling, Trondheim, Norway, 20. October: NTNU
- Eck-Olsen, J. (2010). "Managed Pressure Drilling, What It Is and What It Is Not". Lecture TPG4215 High Deviation Drilling, Trondheim, Norway, 27 October: NTNU.
- Godhavn, J.M., Adjunct Professor-Faculty of Engineering Science and Technology
Department of Petroleum Engineering and Applied Geophysics, NTNU. (2012). "Personal communication"
- Graham, R., Lead Engineer UBD/MPD Statoil ASA. (2011). "Personal communication"
- Guo, B., Ghalambor, A.: "Pressure Stability Analysis for Aerated Mud Drilling Using an Analytical Hydraulics Model" Paper SPE 91356 presented at the SPE/IADC Underbalanced Technology Conference and Exhibition, 11-12 October 2004, Houston, Texas
- Guo, B., Liu, G. (2011). "Applied drilling circulation systems". University of Louisiana at Lafayette and Pegasus Vertex, Inc.

- Lyons, W.C., Guo, B., Graham, R.L., Hawley, G.D. (2009). "Air and gas drilling manual". Gulf Professional Publishing., Burlington, USA
- MI SWACO. (1998). "Mud/Gas Separator"
Retrieved 25.04.2012 from:
http://www.slb.com/~media/Files/miswaco/product_sheets/offshore%20mud%20gas%20separator.ashx
- MI SWACO. (2010). "Drilling chokes, Protect your well with dependable, secure pressure control"
Retrieved 03.11.2011 from:
http://www.slb.com/~media/Files/miswaco/brochures/Drilling_Chokes.ashx
- Mykityw, C.G., Davidson, I.A., Frink, P.J.: "Design and Operational Considerations to Maintain Underbalanced Conditions with Concentric Casing Injection" Paper SPE presented at the IADC/SPE Underbalanced Technology Conference and Exhibition held in Houston, Texas, USA March 2003
- Pèrez-Tèllez, C., Smith, J.R., Edwards, J.K.: "Improved Bottomhole Pressure Control for Underbalanced Drilling Operations" Paper SPE presented at the IADC/SPE Drilling Conference held in Dallas, Texas, USA, 2-4 March 2004
- Pèrez-Tèllez, C. 2003 "Improved Bottomhole Pressure Control for Underbalanced Drilling Operations" PhD Dissertation, Louisiana State University, Louisiana (May 2003)
- Ramalho, J., Davidson, I.A.: "Well-Control Aspects of Underbalanced Drilling Operations" Paper SPE presented at the IADC/SPE Asia Pacific Drilling Technology Conference and Exhibition held in Bangkok, Thailand, 13-15 November 2006
- Rehm, B., Schubert, J., Haghshenas, A., Paknejad, A.S., Hughes, J. (2008). "Managed Pressure Drilling". Gulf Publishing Company, Houston, Texas, USA
- Rommetveit, R., Lage, A.C.V.M.: "Designing Underbalanced and Lightweight Drilling Operations; Recent Technology Developments and Field Applications" Paper SPE presented at the SPE Latin American and Caribbean Petroleum Engineering Conference held in Buenos Aires, Argentina, 25-28 March 2001
- Saponja, J.: "Challenges with jointed-pipe Underbalanced Operations" SPE Drilling and Completion, June 1998. Paper SPE 37066 presented originally at the SPE International Conference on Horizontal Well Technology in Calgary, 18-20 November 1996
- SPT Group. (2012). "Information web side about Dynaflo-drill"
Retrieved 01.05.2012 from:
<http://www.sptgroup.com/en/Products/Drillbench/UBD/Dynaflo-drill/>

SPT Group. (2012). “Information web side about Steadyflodrill”

Retrieved 01.05.2012 from:

<http://www.sptgroup.com/en/Products/Drillbench/UBD/Steadyflodrill/>

SPT Group. (2011). “Drillbench Dynafldrill User Guide”