

# Study of a 145 MHz Transceiver

**Roger Birkeland**

Master of Science in Electronics

Submission date: June 2007

Supervisor: Odd Gutteberg, IET

Co-supervisor: Morten Olavsbråten, IET



# Problem Description

Based upon requirements and findings from a preliminary study of a small satellite project at NTNU, the student will propose possible solutions for a 145 MHz VHF transceiver, build from off-the-shelf components. The assignment includes radio system design, defining a link budget within available power resources. The student will outline a few design options and for the chosen one, find suitable components and build evaluation designs to analyse these. In addition, the student will be a part of the project management team project. The project continues work carried out during the 9th semester project, autumn 2006.

Assignment given: 21. January 2007  
Supervisor: Odd Gutteberg, IET



# Study of a 145 MHz Tranceiver

Roger Birkeland

June 27, 2007

# Preface

This report is the result of a master thesis at Department of Electronics and Telecommunications, the spring of 2007. I have mainly worked with a proposal for a VHF transceiver, intended for small satellite projects, presented in Part I. In addition, I have been involved in the student satellite project on project management level. This work has been carried out in collaboration with Erik Narverud. In addition, all students that worked with theses on the satellite project had weekly meetings during the design phase. A summary of this work is presented in part II. The project work resulted in a System Design Review meeting and presentations for future students.

The work has been very interesting, and very challenging. Lab work has been carried out, all the way from drawing PCB board outlines with Eagle, prototype board milling and assembly and final testing. The ambition level was set quite high, a prototype for parts of the radio was the goal, but as always, lab work takes more time and is more complicated than planned for. The project management work also took a lot of time, but gave me a look into the challenges of project management involving several departments and collaborators. All in all, I see this as one of my biggest and most exciting challenges so far. This has given me much valuable practical experience, not so easily obtained in a more theoretical assignment.

## Acknowledgments

I would like to thank my supervisors Odd Gutteberg and Morten Olavsbråten for their involvement and support during my work. Terje Mathiesen deserves thanks for help and advice during PCB milling. Also, I want to thank Erik for his help and co-operation, and Jan and Kjell and Elisabeth for their involvement in the satellite projects. At last, I want to thank friends Trond, Amund and Stian for their social support and input during the last five months.

Trondheim 27th June 2007

Roger Birkeland

### **Abstract**

After the planning phase autumn 2006, the work with the student satellite project evolved into sub-system design and prototyping. The work presented in this report considers a proposal for a VHF radio system intended for a small student satellite. The design process started on scratch, not looking much at earlier ncube designs, almost no documentation is to be found about actual construction and final measurements. Three design concepts were developed, one featuring an integrated transceiver, one as a self-designed FSK radio and the last one uses a GMSK-modem to solve modulation and de-modulation issues. As the design was chosen and the work of selecting components commenced, it became clear the chosen design would become not unlike the receiver proposed for ncube. The reason for this is component availability, especially the SA606 IF-sub-system and the GMSK-modem.

During test and measurement, a few issues were discovered. The proposed low noise amplifiers seems to be a dead end for this frequencies, and alternatives must be found. The layout for the SA606 is improved and seems to function as required. Since the chosen layout is quite similar to the previous ncube 145 MHz receiver, it shows that the components selected for this designs are a good solution. However, the design is so extensive more work is required before a prototype is ready. It can be questioned if the first design proposal would have been less extensive and could have lead to a finished prototype withing the assigned time frame. Anyway, link budgets and power estimates shows that it is possible to build such a system within the defined limits.

# Contents

<b>1</b>	<b>Background</b>	<b>1</b>
<b>I</b>	<b>VHF Transceiver</b>	<b>2</b>
<b>2</b>	<b>Introduction</b>	<b>3</b>
<b>3</b>	<b>Theory</b>	<b>4</b>
3.1	Radio Communication . . . . .	4
3.2	Wave Propagation . . . . .	4
3.2.1	Free Space . . . . .	4
3.2.2	The Atmosphere . . . . .	5
3.2.3	Other Propagation Effects . . . . .	8
3.3	Radio System Design . . . . .	8
3.3.1	Transmitter . . . . .	8
3.3.2	Receiver . . . . .	9
3.4	Digital Communication . . . . .	10
3.4.1	Modulation Methods . . . . .	10
3.4.2	Signal Quality . . . . .	13
3.5	Link Budget . . . . .	14
3.6	Dynamic Range and P1 . . . . .	15
<b>4</b>	<b>System Design</b>	<b>16</b>
4.1	Similar Projects . . . . .	16
4.2	Link Budget . . . . .	17
4.2.1	Defined and Estimated Parameters . . . . .	17
4.3	Power Budget . . . . .	21
4.4	System Design Overview . . . . .	21
4.5	Selecting Components . . . . .	23
4.6	Transmitter . . . . .	23
4.6.1	Filters . . . . .	25
4.6.2	Mixer . . . . .	25
4.6.3	Buffers and Power Amplifier . . . . .	25
4.7	Receiver . . . . .	25
4.7.1	IF Subsystem . . . . .	26
4.7.2	Digital Signal Processing . . . . .	27
4.8	RX/TX Switch and Antenna Connection . . . . .	28



<b>5</b>	<b>Actual Construction</b>	<b>30</b>
5.1	Prototypes and Evaluation Boards . . . . .	30
5.1.1	IF-subsystem - SA606 . . . . .	30
5.1.2	LNA - RF2472 . . . . .	33
5.1.3	Mixer - ASK-1 . . . . .	34
5.1.4	Low pass filter - LFCN160 . . . . .	35
5.1.5	GMSK-modem - CMX909B . . . . .	35
5.1.6	Switch - HSWA-2 . . . . .	36
5.2	Digital Signal Processing . . . . .	37
5.2.1	GMSK Modem . . . . .	37
5.2.2	MCU Software . . . . .	38
<b>6</b>	<b>Measurements and Evaluation</b>	<b>39</b>
6.1	Test Equipment . . . . .	39
6.1.1	Test Setup - Network Analyzer . . . . .	40
6.2	LNA - RF2472 . . . . .	40
6.3	RF2878 - Simulation . . . . .	42
6.3.1	Results . . . . .	42
6.4	Mixer - ASK-1 . . . . .	46
6.4.1	Down converter . . . . .	46
6.5	Low pass filter - LFCN160 . . . . .	48
6.6	IF Subsystem - SA606 . . . . .	50
6.6.1	First Test . . . . .	51
6.6.2	Second Test . . . . .	54
6.7	GMSK-modem - CMX909B . . . . .	55
6.7.1	Transmit Mode . . . . .	55
6.7.2	Receive Mode . . . . .	56
6.8	Power Estimate . . . . .	57
<b>7</b>	<b>Discussion</b>	<b>59</b>
7.1	Overall Design . . . . .	59
7.2	Digital Part . . . . .	59
7.3	Analogue Side . . . . .	60
7.4	Amplifiers . . . . .	60
7.5	Filters . . . . .	60
<b>8</b>	<b>Conclusion</b>	<b>62</b>
8.1	Further Work . . . . .	63
<b>II</b>	<b>Student Satellite Project</b>	<b>64</b>
<b>9</b>	<b>Background</b>	<b>65</b>
<b>10</b>	<b>Project Work</b>	<b>66</b>
10.1	Project Assignments and Master Theses . . . . .	66
10.2	Student Presentations . . . . .	66
10.3	System Design Review Arrangement . . . . .	67
10.4	Technical Interchange Meetings . . . . .	67
10.5	Other Institutions . . . . .	67

<b>11 Project Database Development</b>	<b>69</b>
<b>12 Project Database Documentation</b>	<b>70</b>
12.1 Project Database . . . . .	71
12.2 Web Page . . . . .	71
12.2.1 Administration . . . . .	72
<b>13 Conclusion</b>	<b>73</b>
<b>III Appendices</b>	<b>76</b>
<b>A SA606 - Documentation</b>	<b>77</b>
A.1 Schematic . . . . .	77
A.2 Board Layout . . . . .	79
A.3 Component Values . . . . .	81
A.4 Test Results - Test 1 . . . . .	81
A.5 Test Results - Test 2 . . . . .	87
<b>B ASK-1 - Documentation</b>	<b>89</b>
B.1 Schematic . . . . .	89
B.2 Board Layout . . . . .	90
B.3 Test Results . . . . .	90
<b>C PIF-40 - Test Results</b>	<b>92</b>
<b>D LFCN-160 - Documentation</b>	<b>94</b>
D.1 Schematic . . . . .	94
D.2 Board Layout . . . . .	94
D.3 Test Results . . . . .	95
<b>E RF2472 - Documentation</b>	<b>98</b>
E.1 Schematic . . . . .	98
E.2 Component Values . . . . .	98
E.3 Board Layout . . . . .	99
E.4 Communication with RFMD . . . . .	99
<b>F HSWA-2 - Documentation</b>	<b>101</b>
F.1 Schematic . . . . .	101
F.2 Board Layout . . . . .	102
<b>G RF2878 - Simulations</b>	<b>103</b>
<b>H CMX909B - Documentation</b>	<b>106</b>
H.1 Schematic . . . . .	106
H.2 Board Layout . . . . .	107
H.3 Source Code . . . . .	107
<b>I System Design Review</b>	<b>123</b>
<b>J Student Presentation</b>	<b>154</b>

# List of Abbreviations

ADCS	Attitude Determination and Control System
ARQ	Automatic Repeat reQuest
BPSK	Binary Phase Shift Keying; a modulation method
CRC	Cyclic Redundancy Check
FEC	Forward Error Correction
FR-4	Flame Resistant 4, a PCB type
FSK	Frequency Shift Keying; a modulation method
GaAs	Gallium Arsenide
GMSK	Gaussian Minimum Shift Keying; a modulation method
GPS	Global Positioning System
IDI	Department of Computer and Information Science
IET	Department of Electronics and Telecommunications
ITK	Department of Engineering Cybernetics
LiIon	Lithium-Ion
LiPoly	Lithium-Polymer
LNA	Low Noise Amplifier
MCU	MicroController Unit
MSK	Minimum Shift Keying; a modulation method
NAROM	Norwegian Centre for Space-related Education
NTNU	Norwegian University of Science and Technology
OBDH	On-Board Data Handling
P-POD	Poly Pico-satellite Orbital Deployer
PA	Power Amplifier
PCA	Printed Circuit Assembly

PCB Printed Circuit Board  
PLL Phase Locked Loop  
PSK Phase Shift Keying; a modulation method  
Rad-Hard Radiation hardening  
RX/TX Recieve/Transmit  
TCXCO Temperature Controlled Crystal Oscillator  
TT&C Telemetry, Tracking and Command  
VCO Voltage Controlled Oscillator  
VSG Vector Signal Generator  
VXCO Voltage Controlled Crystal Oscillator

# Chapter 1

## Background

During the autumn of 2006, a pre-study project of a small student satellite at NTNU was launched. Three students, Elisabeth Karin Blom, Erik Narverud and Roger Birkeland worked with this task as their 9<sup>th</sup> semester project. The work resulted in a report defining subsystems and some general outlines for the project [1].

This report is a further study of radio hardware intended for the Telemetry, Tracking and Command-subsystem (TT&C). In addition, a sum-up from the project work this semester will be presented in Part II. Except for the chapter Project Database Documentation, Part II is written in collaboration with Erik Narverud, and also included in his thesis. Part I will go through system design, component selection and manufacturing of evaluation boards. The TT&C coder and decoder will not be considered.

The radio system design starts off more or less from scratch, trying to find a suitable design without but as the design is chosen

**Part I**

**VHF Transceiver**

## Chapter 2

# Introduction

The communication part of a satellite system is one of the fundamental systems, so as a follow up from project work done autumn 2006, further work on radio systems commenced January 2007. Based on the outlines in the specification, hardware for the Telemetry, Tracking and Command (TT&C) radio system should be developed. This includes finalizing link budgets, setting design criteria, finding a suitable design proposal and carry out measurements on components. The design must be evaluated on the end, to see if it can be used as basis for a later engineering model. A second goal, maybe as much important, is to build a reference and document database. It is seen from earlier projects of this kind that a lack of documentation brings each successive student to almost start from scratch on his own work. This is one of the overall main problems with a student driven project, supposed to last several years.

Even if several students during the last few years have worked on similar projects, there are too little documentation on construction and testing to build upon. Therefore, it is hard to base construction of a radio system upon earlier designs. The thought was to start over again to evaluate several design proposals against each other.

In this report, not all parts of the TT&C-system will be discussed, the main focus lies upon the radio hardware. An overview of the radio system will be presented, as well as link-budgets and power estimates. Off-the-shelf radio components will be found and evaluated throughout the design and evaluation process. In addition to mixers and amplifiers, the system needs utilities for digital signal processing, both hardware and software. Anyway, the report will not discuss the TT&C-coding and de-coding, as the TT&C-protocol and operation is not yet defined.

## Outline

Part I the report will go through basic radio system theory in chapter 3, leading to a link budget in chapter 4. The link budget then leads to defining component parameters and selection in chapter 5. Only the selected components are discussed even if several was evaluated. Lastly, measurements will be presented and discussed in chapters 6 and 7.

# Chapter 3

## Theory

This chapter will sum up some basic theory for radio system design, presented in pre-study report [1]. Some sections are taken directly from the pre-study, others are new or reworked.

### 3.1 Radio Communication

One of the fundamental parts of an operational satellite system is its communication system. The satellite being several kilometers from the user on Earth, making radio communication required. Several challenges are evident. A satellite orbiting the Earth in Low Earth Orbit (LEO) will be visible only for a short period of time, hence antenna tracking might be needed on the ground station. A small satellite such as a cubesat will have limited power resources available; output power is limited. In addition, low frequency operation, such as the VHF band, require relatively large antennas on the satellite. Also, the signal will be degraded due to ionospheric and tropospheric effects.

Because of the long distance between the sender and receiver, the radio hardware must be able to operate on, and detect, small signal levels. Thus, sensitivity and noise properties of the receiver are important.

### 3.2 Wave Propagation

A radio wave traveling between a satellite and ground station, will experience different effects while propagating through different media.

#### 3.2.1 Free Space

Free space path loss is the path loss occurring if no other influences other than the propagation properties of far-field electromagnetic waves through free space are taken into account. According to [2] the loss can be written as:

$$L_0 = \left( \frac{4\pi r}{\lambda} \right)^2 \quad (3.1)$$



The loss  $L_0$  is proportional with the distance,  $r$ , between the transmitter and receiver antenna squared, and inversely proportional with the wavelength,  $\lambda$ , squared. The radiated energy spreads outward from the radiating element in a spherical form. The energy is spread over an increasing area, but the signal is not distorted in any way.

The effective isotropic radiated power (EIRP) equals  $P_t G_t$ , where  $P_t$  is transmitted power to the antenna, and  $G_t$  is the antenna gain. Put together with the receiving antenna gain and effective aperture, the known form of the Friis equation is obtained [2].

$$P_r = P_t G_t G_r \cdot \frac{1}{L_0} = P_t G_t G_r \cdot \left( \frac{\lambda}{4\pi r} \right)^2, \quad (3.2)$$

where  $P_r$  is received power at the receiving antenna and  $G_r$  is the receiving antenna gain. The equation is the basis for the calculations leading to the link budget, defining the radio link parameters. All other losses can be added to this equation.

### 3.2.2 The Atmosphere

#### Ionosphere

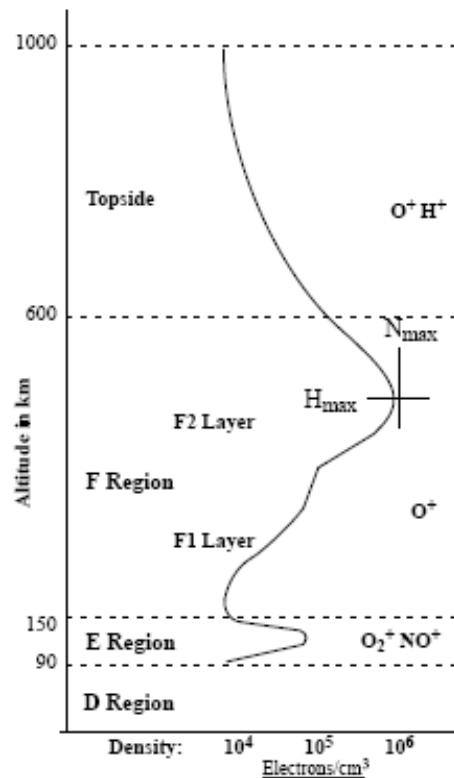

Figure 3.1: Layers of the ionosphere. [3]

The ionosphere is the outermost part of the Earth's atmosphere, consisting of different layers as shown in figure 3.1. When radiation from the sun strikes atoms and molecules in the ionosphere, it leads to ionizing. The result is ionospheric plasma, which conducts electricity. The different layers have different refractive indexes, hence an electromagnetic wave will be bent when it reaches a border between layers. If the frequency is very low, the wave will be reflected back toward the Earth. The maximum electron density determines the maximum frequency which will be reflected.

Sunspot activities play an important role, as ionization also is caused by high energy particles from the Sun. Solar flare intensity varies in an 11-year cycle, as seen in figure 3.2. The sunspot cycle is expected to increase from a minimum in 2006-07 toward a maximum in 2010-11.

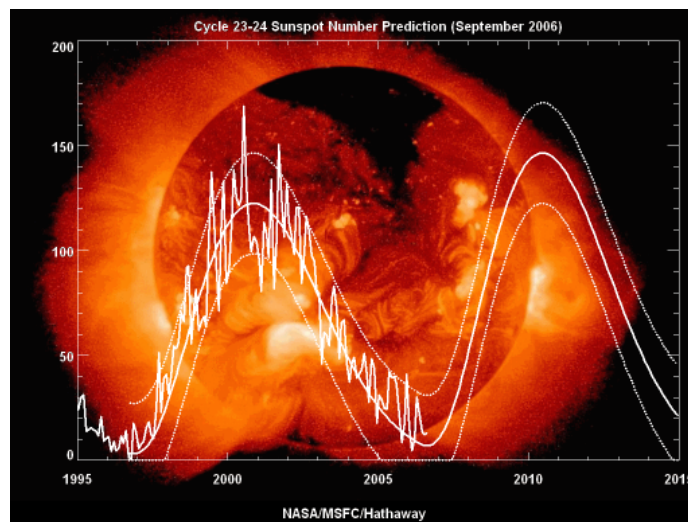

Figure 3.2: Sunspot cycle predictions. Source: NASA

The aurora amplifies the effect of ionization in the polar regions. Charged particles spiral toward the poles along the magnetic field lines of the Earth and strike the atmosphere at high speeds, causing ionization. The aurora oval exists at latitudes above 60 degrees, on both hemispheres [3]. All ground stations considered in this project lie within areas affected by the auroral oval, though Svalbard and Narvik are more vulnerable than Trondheim.

**Scintillation** Incident radiation can cause turbulence in smaller parts of the ionosphere, leading to rapid changes in the electron density. These density fluctuations cause huge and random variations in received signal levels, i.e. strong signal fades. Such causes and effects are introduced in [3] and discussed in more detail in [4].

It is found from several studies and measurements during the 1970s and 1980s that scintillation can have severe impact upon radio signals in the UHF and VHF bands. A radio signal can experience huge fluctuations in amplitude, varying with time of day, the time after sunset is the worst [3]. The effect is worst at low frequencies, at northern latitudes and in a band near equator.

This means the effect should be considered when finalizing link budgets and system margins for the student satellite system.

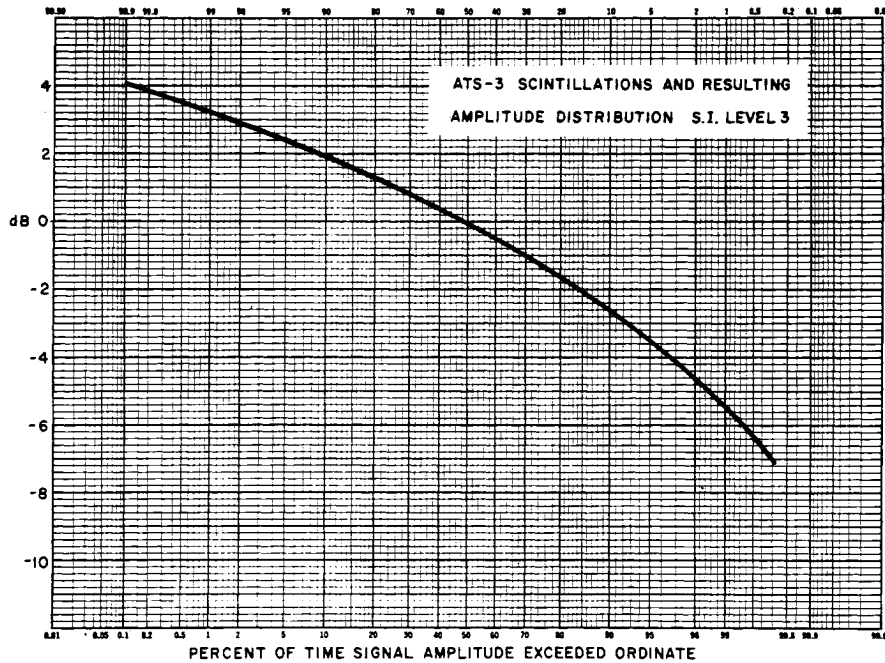

Figure 3.3: Example of recorded scintillation data. Source: [4]

Figure 3.3 shows an example of scintillation data, showing amplitude distribution in dB v.s. percentage of time for one dataset, recorded at Sagamore Hill 1969.

From [5] it is seen from measurements on Greenland in between 1979 and 1984 that the intensity scintillations can be larger than 30 dB at 250 MHz at some time intervals, so scintillations can have huge impact on radio waves at VHF.

### Troposphere

A radio wave propagating through the Troposphere can experience several effects, such as absorption, cloud and rain attenuation, ice crystal depolarization and tropospheric scintillation. The severity of these effects are strongly dependent upon the frequency.

The warming-up of the Earth's surface by the sun causes convective activity, mixing different tropospheric layers. The result is that the refractive index varies rapidly along the path of the signal, which leads to fluctuations in the received signal power. Factors that cause an increase in the fluctuation level are increasing frequency and a lower elevation angle. If the elevation angle is low enough, low angle fading becomes an issue [6]. Signal components arriving at the receiver may have been refracted differently in the atmosphere (at the boundary layers), and subsequently phase-shifted in relation to each other, either attenuating or amplifying the signal.

Rain attenuates the carrier and contributes to the noise temperature. In [6], it is found that the attenuation and contribution to the total noise temperature is small and negligible, even at a low elevation angle of  $30^\circ$  at VHF frequencies.

### 3.2.3 Other Propagation Effects

The assigned communication band is also used by other satellite projects, this can lead to interference, both at the satellite and at the ground station. It can be assumed that there will be no other satellite in near vicinity to cause interference. Also, the probability of someone randomly transmitting a strong VHF signal directed at the satellite can be assumed small.

One countermeasure to improve signal quality and integrity is to use multiple receivers, located in different locations, introducing site-diversity gain.

At last, it is assumed that the ground station will have clear view of the satellite during the whole transmission period, so multi-path signals can be neglected.

## 3.3 Radio System Design

There are several topics to be addressed when designing a radio system, this include determining the data rate, which leads to bandwidth, power and modulation issues. The power is available limited, so the designer must adjust the demands within achievable limits. The designer must make some assumptions on the transmission path and define transmitter and receiver parameters. In the link budget, power margins must be introduced to take effects discussed above into account. Also, the signal can also be depolarized due to satellite rotation and effects like Faraday rotation, causing further degradation of signal quality.

### 3.3.1 Transmitter

Important and defining parameters for a transmitter will be mostly be dependent upon its final Power Amplifier (PA) stage and the antenna. Also, the up-converter will create other side-bands and inter modulation products. These must be filtered out as good as possible. A certain Equivalent Isotropically Radiated Power (EIRP) is needed to provide a strong enough signal to be received at the ground station, and the amplifier must be so linear it meets the demands for the given modulation method. When operating in a system with limited power, it is very important that the PA has high efficiency. If the output effect must be in the order of 1 W, with an amplifier yielding 50% effectivity, the power delivered to the amplifier must be 2 W. This also imposes a potential challenge with cooling.

The antenna must also match the purpose; it must be decided if the antenna should be omni directional, or of high directivity. This depends upon the use of the radio link, and how the satellite is controlled. For a TT&C-system (and a satellite with less antenna control), an omni directional antenna, like the one discussed in [1], will be preferred to communication possibilities at all satellite orientations.

### 3.3.2 Receiver

For a receiver, some defining parameters are noise temperature, antenna gain, noise factor of the low noise amplifier (LNA), LNA gain and demodulator sensitivity.

#### Noise

There are mainly two different sources of noise. One is received noise by the antenna, the other is internal generated thermal noise generated by receiver components.

**External Noise** General, a ground station receiver antenna will pick up noise from the Sun, Moon, the ionosphere, troposphere, the Earth and general background radiation. If narrow antenna beam is assumed, as the case for a tracking antenna will be, contribution from the sun and moon can be ignored. An indication of noise temperature  $T_b$  for different elevation angles can be found in [6]. In general, it can be seen that the noise temperature increases with a decreasing elevation angle. The noise temperatures are high for frequencies lower than a few hundred MHz. Worst case of the minimum elevation angle  $T_b = 500$  K for  $f = 145$  MHz. When the satellite is at zenith (elevation  $90^\circ$ ), the temperature is  $T_b = 50$  K.

The receiver  $G/T$  ratio, where  $G$  is the antenna gain and  $T$  is the system temperature, is a descriptive factor for the receivers, because  $G/T$  is proportional to the signal-to-noise ratio at the input to a receiver.

For the satellite receiver, the received noise temperature will be more or less constant, as the satellite will see approximately the same portion of the Earth at all times.

**Internal Noise** White noise sources can be thought of as a equivalent thermal noise source, with a corresponding noise temperature modeled by a noisy resistor at a temperature equal to noise temperature. This way, the component can be considered noiseless, while the noisy resistor is referenced at the input of the component.

The noise figure is a relation between the signal-to-noise ratios of the input and output of the noisy component. The related noise temperature is found in [2] as:

$$T_e = (F - 1)T_0, \quad (3.3)$$

where  $T_e$  is the equivalent noise temperature and  $F$  is the corresponding noise factor.  $T_0$  is by definition 290 K.

All noise sources can be calculated to the same reference point, in front of the receiver, added together to the systems total system noise temperature.

The noise factor of the first component in a receiver chain is the most important.

$$T_e = T_{e1} + \frac{T_{e2}}{G_1} + \frac{T_{e3}}{G_1 G_2} + \dots \quad (3.4)$$

In [2, p. 92], equation 3.4 is found, and it is shown that when cascading components, noise from components placed after components with high gain will contribute very little to the overall system noise temperature.

Thus, finding a LNA with reasonably high gain and low noise factor is important. Mixers for instance, will have high noise factors, but placed after a good LNA they will only contribute to a small increase in noise level. It is also shown that losses *before*<sup>1</sup> the first gain element must be avoided, as such losses will add directly to the overall noise temperature.

From equation 3.2 and adding the receiver chain, the carrier-to-noise ratio at the demodulator becomes:

$$\frac{C}{N} = \frac{G_r}{T_s} \cdot \frac{P_t G_t}{kB} \cdot \left( \frac{\lambda}{4\pi r} \right)^2 \quad (3.5)$$

Here,  $T_s$  is the equivalent system noise temperature at the demodulator, and  $C$  is the carrier power.

In equation 3.5, the factor  $N = kT_s B$  is the noise power.  $k = 1.38 \times 10^{-23}$  J/K is Boltzmann's constant. Noise power from the channel bandwidth  $B$  will contribute to signal degrading, hence a narrow channel will have less noise than a broadband channel.

## 3.4 Digital Communication

As a part of the TT&C-system, the radio will be used to communicate digital data between the satellite and the ground station. Several modulation methods is available, but it could be favorable to choose a phase (or frequency) modulation to ease linearity demands on the amplifiers. Frequency Shift Keying (FSK) can generally be preferred to Phase Shift Keying (PSK) due to the possibility of none-coherent demodulation[7].

### 3.4.1 Modulation Methods

#### Frequency Shift Keying

FSK modulation can be explained as assigning two symbols, for example "1" and "0" a certain frequency,  $f_i$ , each. In [7, chapter 6.5] the following is found about coherent FSK.

$$s_i(t) = \begin{cases} \sqrt{\frac{2E_b}{T_b}} \cos(2\pi f_i t), & 0 \leq t \leq T_b \\ 0, & \text{elsewhere} \end{cases} \quad (3.6)$$

Where  $s_i(t)$  is the signal with a given frequency,  $f_i$ ,  $i = 1,2$  and  $E_b$  is the transmitted signal energy per bit. The transmitted frequencies is found by:

$$f_i = \frac{n_c + i}{t_b} \text{ for some fixed integer } n_c \quad (3.7)$$

The frequency deviation will be equal to the bit rate, and  $n_c$  sets the carrier frequency.

---

<sup>1</sup>Such losses can be from antenna cable and connections and filters prior to LNA

The resulting signal constellation is shown in figure 3.4, where the message points shows two orthogonal signal vectors. Further study of FSK is found [7, chapter 6.5].

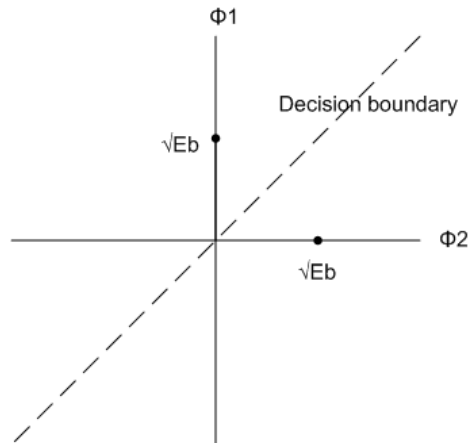

Figure 3.4: FSK Constellation - Coherent FSK

**Generation** In the easiest form, (binary) FSK modulation can be created by applying a data stream to voltage controlled oscillator (VCO), hence the VCO will generate a signal with two alternating frequencies if the input signal has two levels. For use in a satellite radio system, an important case to consider is the stability of the VCO in different temperature ranges, also its dynamic range and stability regarding the output frequency v.s. the input signal level.

### Gaussian Minimum Shift Keying

Minimum Shift Keying (MSK) is a form for FSK where the phase information in the signal is better exploited to improve noise properties [see 7, chapter 6.5]. Two more message points are added to the constellation; two of them are mapped to "0" and the other two are mapped to "1". See figure 3.5. It is worth noting that for MSK the decision boundary lies on the axes, in contradiction to the border for the FSK signal.

This leads to the maximum phase shift of  $\pi/2$  between each signal, thus resulting in smoother transition between symbols.

Gaussian Minimum Shift Keying (GMSK) is a form of MSK where the bit-stream is filtered by a baseband pulse shaping filter prior to the modulation. This gives better out-of-band properties than ordinary MSK. [7, chapter 6.5] This is clearly shown in figure 3.6, which shows spectral density plots for ordinary MSK and for GMSK with different time-bandwidth products. However, Gaussian filtering will lead to inter-symbol-interference and some reduced noise properties with comparison to ordinary MSK. The Gaussian filter will make a symbol wider than its bit period so the symbol will overlap adjacent symbols.

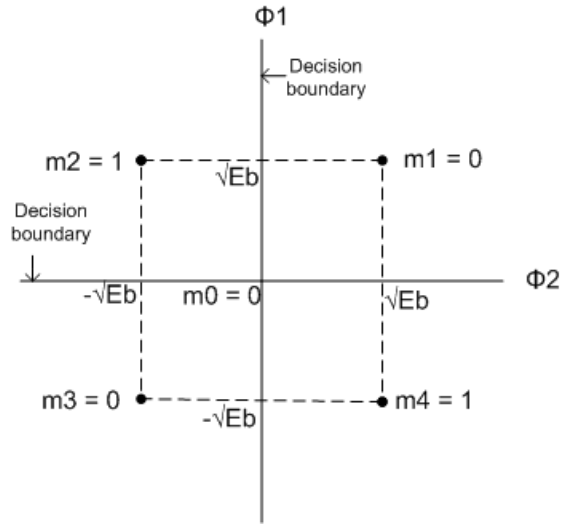

Figure 3.5: MSK Constellation

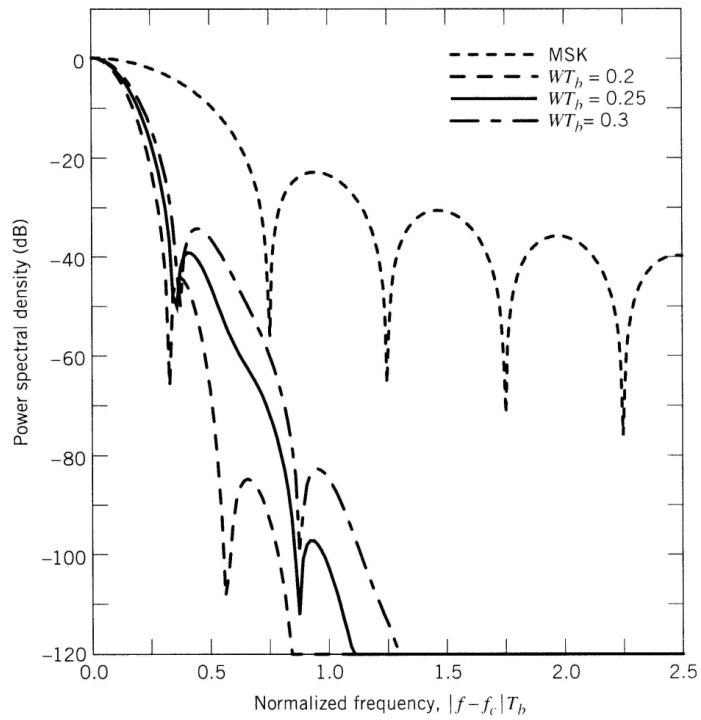

Figure 3.6: Power Spectral Density for a few modulations. Source: [7]



### 3.4.2 Signal Quality

The quality of a received signal is given by its Carrier-to-Noise ratio,  $C/N$  in equation 3.5. For digital signals, energy per bit over the spectral noise density,  $E_b/N_0$ , is the important factor.

The relationship between carrier-to-noise ratio  $C/N$  and  $E_b/N_0$  is given by: [2]

$$\frac{C}{N} = \frac{R_b}{B} \cdot \frac{E_b}{N_0}, \quad (3.8)$$

where  $E_b$  is the energy per bit and  $N_0$  the noise power spectral density. The value of  $E_b/N_0$  determines the Bit-Error-Rate (BER) for a given modulation method.  $R_b$  is the bit rate. The larger the number, the better is the signal quality. The BER should naturally be sought as low as possible. Different applications will in general have different requirements. A often used BER-rate can be  $10^{-6}$ .

The error probability  $P_e$  for coherent FSK, GMSK and MSK with equiprobable symbols is found in [7, chapter 6.5] and is for FSK given by:

$$P_e = \frac{1}{2} \operatorname{erfc} \left( \sqrt{\frac{E_b}{2N_0}} \right) \quad (3.9)$$

For GMSK the following applies:

$$P_e = \frac{1}{2} \operatorname{erfc} \left( \sqrt{\frac{\alpha E_b}{2N_0}} \right) \text{ BER for GMSK,} \quad (3.10)$$

where  $\alpha$  is a constant dependent upon the time-bandwidth product of the Gaussian filter.

Error probability for ordinary MSK is given by:

$$P_e = \frac{1}{2} \operatorname{erfc} \left( \sqrt{\frac{E_b}{N_0}} \right) \text{ BER for MSK} \quad (3.11)$$

It is seen from equations 3.10 and 3.11 that some of the improved BER for MSK compared to FSK is lost for GMSK, when trading this off for improved spectrum properties. For this application  $\alpha = 0.5$ .

### Error Detection and Correction

Noise are added by several sources, and the propagation media can introduce signal fades. All these effects degrades the signal quality, so for a combination of attenuation, added noise and phase shifts, some symbols might cross decision boundaries. The result is a faulty decision by the demodulator. Several solutions are available to improve the situation. If the receiver detects a damaged package, it can ask the sender to re-transmit. This is called Automatic Repeat reQuest, ARQ [7]. Another widely used way of improving correct decision is to introduce redundancy in the data stream. Parity and/or CRC bits are added to the data package. The receiver can then calculate CRC-bits based on the received package, and the decide if the received data is valid. If it is not desirable to add extra bits, the receiver can try to decode the message, looking for known code words. If decoding fails, a re-transmission can be requested.

The receiver can also be able to correct some bit errors, by adding Forward Error Correction (FEC) bits to the package. The receiver is able to both detect most errors and correct some of them. FEC reduce the usable bit rate as

$$R = \frac{k}{n}, \text{information bits per code bit} \quad (3.12)$$

but this can ensure safer data transmission and maybe allow reduction of the needed transmitted power. This increase in  $\frac{E_b}{N_0}$  is called *code gain*. Code gain can be difficult to calculate, and can be dependent upon  $E_B/N_0$  also. Therefore, and since the margins in this link budget will be fairly huge, code gain will not be further discussed. Generally, code gain,  $Cg$ , can be included in the previously introduced transmission equation as shown below

$$\frac{E_b}{N_0} = \frac{G_r}{T_s} \cdot \frac{P_t G_t}{kB} \cdot \left( \frac{\lambda}{4\pi r} \right)^2 \cdot \frac{B}{R_b} \cdot Cg \quad (3.13)$$

An Earth-to-satellite link has a high round-trip delay time and using ARQ, retransmissions would occur frequently and take up a lot of time. A decoder using FEC attempts to correct errors at the receiver would be better. It determines the most likely error to have occurred and corrects it, using known code properties.

**Interleaving** Together with ARQ, interleaving is a method to reduce bit errors in a received word without adding overhead bits. As shown, a fade can for instance be caused by ionospheric scintillation. These errors often occur in burst, they are often too long to be detected and/or corrected by FEC. Anyway, a fade might not last the whole package time. An interleaver changes the transmitted data sequence, separating adjacent bits in a word, thus spreading the error over many codewords. This increases the possibility of correcting the errors. The size of the interleaver must be so large that the codeword bits is spread enough to not be affected by the same fade.

**Scrambling** Scrambling is a technique used to smooth the transmitted spectrum, in addition to ensure a more random transmitted bit-sequence. The goal is to remove all correlation in the transmitted signal. This will also eliminate long sequences of ones and zeros, helping bit-timing recovery, without the need to add redundant code to the signal. This is a one-to-one mapping of a signal sequence on a pseudo-random code [8, chapter 19.5]. The scrambling code must be known to the receiver.

### 3.5 Link Budget

As worked out throughout this chapter, a equation describing data transmission through the satellite link is found.

$$\frac{E_b}{N_0} = \frac{G_r}{T_s} \cdot \frac{P_t G_t}{kB} \cdot \left( \frac{\lambda}{4\pi r} \right)^2 \cdot \frac{B}{R_b} \cdot Cg \cdot \frac{1}{M'} \quad (3.14)$$

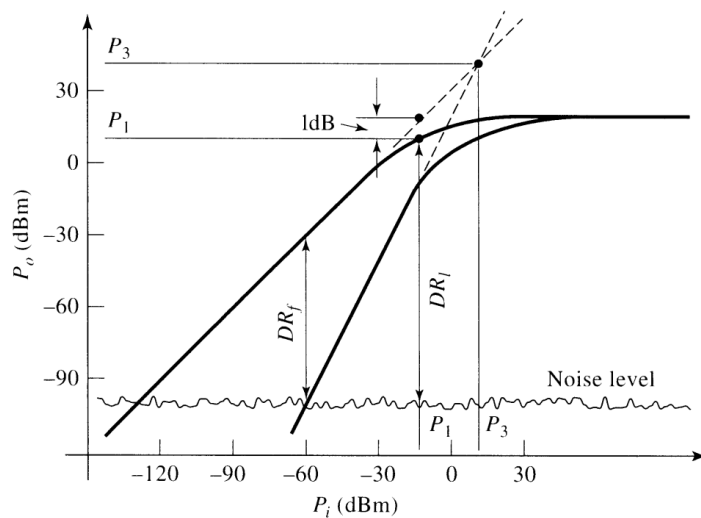

Figure 3.7: Dynamic range, definition. Source: [2]

where  $M$  is the *link margin* to take account for other losses. The parameters must be adjusted so that  $\frac{E_b}{N_0}$  is high enough to give the required bit-error-rate, with sufficient link margin. This equation will be the foundation for one link budget for each link; up and down.

The link budget will show if parameters like transmission power, antenna gain and bandwidth and bit rate are achievable. Two link budgets are developed for each link; one best and one worst case.

### 3.6 Dynamic Range and P1

An amplifier will not be able to operate on all input signal levels. If the input signal is too strong, the amplifier will saturate, and start to operate outside its linear area. This must be taken into account when selecting buffers and amplifiers. This also holds for other components like mixers and switches.

Figure 3.7 (from [2]) shows how an amplifier's dynamic range is defined; between the noise floor for low power levels, and the P1 point for high power levels. Compression point P1 is most important in this case; the point is defined where the actual output of the amplifier lies 1 dB under the "ideal" linear curve.

## Chapter 4

# System Design

When designing a radio system, several issues must be addressed. Some important matters are listed below.

- Modulation method, and corresponding modulator
- Power amplifier; good linearity, efficiency and dynamic range
- Antenna connection and RX/TX-switch
- Receiver sensitivity
- Baseband recovery and demodulator
- Digital signal processing

Link budgets are a critical tool in design process. They outline all the important system parameters to be taken into account. Parameters must be considered to meet the demands set by the budget and the end user, and usually, the final design is a trade-off between different parameters.

Sensitivity level for the de-modulator and dynamic range for the system must be defined. Components meeting the requirements must be found, and assembled. Selecting components is an iterative process, as components available in the market might have other properties than first wished for, power consumption might trade on component against another and so on.

### 4.1 Similar Projects

Several similar satellite projects was studied in the early project phase. The problem was to find sufficient documentation, both on higher levels and the concrete sub-system designs. It was natural to start with the ncube-project (see web page [9]). Some documentation can be found, but not much about actual construction and testing of the sub-systems.

In table 4.1 some other student projects are listed, all a part of the failed Dneper-launch in Kazakstan July 2006.

As seen, most of the satellites were planned to use the 436 MHz VHF band as down link, output power in the vicinity of 500 mW (27 dBm), and a simple low-rate modulation.

Name	University	Down-link MHz	RF Power	Modulation
CP1	Calpoly	436.85 MHz	300 mW	15 baud DTMF
CP2	Calpoly	437.33 MHz	500 mW	1200 baud FSK
ICE Cube 1	Cornell Uni	437.31 MHz	600 mW	9600 baud FSK
ICE Cube 2	Cornell Uni	437.43 MHz	600 mW	9600 baud FSK
ION	Uni of Illinois	437.51 MHz	2 W	1200 baud FSK
HAUSAT-1	Hankuk Aviation	437.47 MHz	500 mW	1200 baud AFSK
KUTESat	Kansas Uni	437.39 MHz	500 mW	1200 baud AFSK
MEROPE	Montana State	145.98 MHz	500 mW	1200 baud AFSK
nCUBE-1	NTNU	437.31 MHz	1 W	9600 baud GMSK
RINCON	Uni of Arizona	436.87 MHz	400 mW	1200 baud AFSK
SACRED	Uni of Arizona	436.87 MHz	400 mW	1200 baud AFSK
SEEDS	Nihon Uni	437.49 MHz	450 mW	1200 baud AFSK
VOYAGER	Uni of Hawaii	437.41 MHz	500 mW	1200 baud AFSK

**Table 4.1:** A selection of other student satellite programs. Source: cubesat.info

## 4.2 Link Budget

Equation 3.14 defines the overall parameters that must be determined for the radio system. The known, or easily estimated, parameters is the free space loss and satellite antenna gain (known from simulations, see [1]). Other parameters, like noise temperatures is estimated as explained above, and noise factors are found from data sheets and estimates. The important matters is to minimize necessary output power, and maximize  $\frac{E_b}{N_0}$ . In the example shown below, ground station parameters such as output power and antenna gain are given example values to show what might be required.

### 4.2.1 Defined and Estimated Parameters

The antenna gain for the satellite antenna was found in [1] to be 2 dB. Earth stations have better possibilities for large gain than satellite antennas, 20 dB will be used as an estimate.

The antenna temperature for the Earth station receivers is estimated to be 290 K. The satellite antenna see a portion of the Earth at 293 K, and cold space outside (if not sun or the moon), so the noise temperature is estimated to 150 K.

The orbit is unknown for this project, but assumed to be somewhat like previous missions. For the worst case, 800 km orbit height and elevation angle  $20^\circ$  is used. For the best case, 400 km orbit height and an elevation of  $90^\circ$  is used. Cable and connector losses are estimated to 1.5 dB total and LNA noise factor is estimated to 1.5 dB. This is a typical value found for several LNAs. The bit rate is 9600 bps and output power from amplifier is set to 1 W.

Coding gain is not taken into account, since the margins anyway are huge. Minimum  $E_b/E_0$  is set to 10 dB in the link budget. This corresponds to a BER of about  $10^{-6}$ , depending upon  $\alpha$ . The link budget must be revised when all parameters are known.

It is seen from the link budgets that the fading margins for both links will be

Downlink

Link Budget for TT&C transceiver				
Date:	7. mai 07			
Author:	Roger Birkeland			
Common Parameters	Value	Unit		
Carrier Frequency	145000000,00	Hz		
Speed of light	300000000,00	[m/s]		
Carrier Wavelength	2,07	[m]		
Earth Radius	6378000,00	[m]		
Pi	3,14			
Boltzmann's constant	138,1E-25	[J/K]		
Boltzmann's constant	-228,60	[dB/K/Hz]		
Baud Rate	9600,00	[baud]		
Alpha	0,30			
Signal Bandwidth	12480,00	[Hz]		
<i>Noise Power:</i>				
Noise Bandwidth	30000,00 [Hz]	Estimate, IF-filter		
Antenna Temperature	290,00 [K]	Estimate, dependent on angle		
Ambient Temperature	290,00 [K]			
LNA noise figure	1,70 [dB]	Estimate		
Cable and Connector Losses	1,50 [dB]	Estimate		
Noise Factor at Antenna Connection	2,09			
Noise Temperature at Antenna Connection	315,90 [K]			
System Noise Temperature	605,90 [K]			
System Noise Temperature	27,82 [dBK]			
Noise Power (referred to receiver input)	-156,00 [dBW]			
DOWNLINK BUDGET – Best Case		DOWNLINK BUDGET – Worst Case		
Parameters	Value	Unit	Value	Unit
Elevation	90,00	[deg]	20,00	[deg]
Orbit Height	400000,00	[m]	800000,00	[m]
Maximum Distance	400000,00	[m]	1768700,02	[m]
<b>Transmitter: Satellite</b>				
Transmitted power	1,00 [W]		1,00 [W]	
	0 [dBW]		0 [dBW]	
Antenna Gain	2,00 [dB]		2,00 [dB]	
Output RF Power (EIRP)	2,00 [dBW]		2,00 [dBW]	
<b>Propagation Losses</b>				
Free Space Loss	127,71 [dB]		140,62 [dB]	
Polarization Loss	3,00 [dB]		3,00 [dB]	
Attenuation due to ionosphere Scintillation	5,00 [dB]		5,00 [dB]	
<b>Receiver: Ground</b>				
Receiver Antenna Gain (Ground Station)	20,00 [dB]		20,00 [dB]	
Received Power (before antenna)	-113,71 [dBW]		-126,62 [dBW]	
	-83,71 [dBm]		-96,62 [dBm]	
	425,6E-14 [W]		217,7E-15 [W]	
Received C/N (at antenna connection)	42,29 [dB]		29,38 [dB]	
Received Eb/N0 (at antenna connection)	47,24 [dB]		34,33 [dB]	
Minimum Receiver Eb/N0	10,00 [dB]		10,00 [dB]	
Uplink Fading Margin	37,24 [dB]		24,33 [dB]	

Figure 4.1: Down-link Budget

in the order of 20 to 30 dB. This is a fairly huge margin, so it should be possible to account for most of the atmospheric propagation effects as outlined in previous chapters. Anyway, as shown, ionospheric scintillation can, in a relatively small percentage of the time, attenuate the signal severely. With the calculated margins and the narrow satellite visibility window it can be assumed that data transition probably will be possible most of the time.

Uplink

<b>Link Budget for TT&amp;C transceiver</b>	
Date:	7. mai 07
Author:	Roger Birkeland

Common Parameters	Value	Unit
Carrier Frequency	145000000,00	Hz
Speed of light	300000000,00	[m/s]
Carrier Wavelength	2,07	[m]
Earth Radius	6378000,00	[m]
Pi	3,14	
Boltzmann's constant	138,1E-25	[J/K]
Boltzmann's constant	-228,60	[dB/K/Hz]
Baud Rate	9600,00	[baud]
Alpha	0,30	
Signal Bandwidth	12480,00	[Hz]

Noise Power:

Noise Bandwidth	30000,00 [Hz]	Estimated, IF-filter
Antenna Temperature	150,00 [K]	Estimate
Ambient Temperature	290,00 [K]	Estimate
LNA noise figure	1,70 [dB]	
Cable and Connector Losses	1,50 [dB]	Estimate (SW + conn + filter ++)
Noise Factor at Antenna Connection	2,09	
Noise Temperature at Antenna Connection	315,90 [K]	
System Noise Temperature	465,90 [K]	
System Noise Temperature	26,68 [dBK]	
<b>Noise Power (referred to receiver input)</b>	<b>-157,15 [dBW]</b>	

**UPLINK BUDGET – Best Case**

**UPLINK BUDGET – Worst Case**

Parameters	Value	Unit	Value	Unit
Elevation	90,00	[deg]	20,00	[deg]
Orbit Height	400000,00	[m]	800000,00	[m]
Maximum Distance	400000,00	[m]	1768700,02	[m]
<b>Transmitter: Ground</b>				
Transmitted power	5,00	[W]	5,00	[W]
	6,99	[dBW]	6,99	[dBW]
Antenna Gain	20,00	[dB]	20,00	[dB]
Output RF Power (EIRP)	26,99	[dBW]	26,99	[dBW]
<b>Propagation Losses</b>				
Free Space Loss	127,71	[dB]	140,62	[dB]
Polarization Loss	3,00	[dB]	3,00	[dB]
Attenuation due to ionosphere Scintillation	5,00	[dB]	5,00	[dB]
<b>Receiver, satellite</b>				
Antenna Gain	2,00	[dB]	2,00	[dB]
Received Power Pr	-106,72	[dBW]	-119,63	[dBW]
	-76,72	[dBm]	-89,63	[dBm]
	212,8E-13	[W]	108,8E-14	[W]
Received C/N (at antenna connection)	50,42	[dB]	37,51	[dB]
Received Eb/N0 (at antenna connection)	55,37	[dB]	42,46	[dB]
Minimum Receiver Eb/N0	10,00	[dB]	10,00	[dB]
Uplink Fading Margin	45,37	[dB]	32,46	[dB]

Figure 4.2: Up-link Budget



### 4.3 Power Budget

Lastly, the user must make an estimate upon the power needed to run the radio system. This must be within the defining limits of the power available in the total satellite power budget.

With these huge margins, it should be considered to decrease output power. Also, as shown in table 4.1, earlier projects have used an output effect of about 0.5 W. This will reduce the margins with 3 dB, but not lead to a problem for successfully data transmission. As it will be shown later, most of the power needed, are due to the power amplifier. A reduction in output power will clearly benefit the project.

Power allocated to the radio system is 3 W for the transmitter and 0.2 W for the receiver. See the pre-study report [1]

### 4.4 System Design Overview

Three alternative transceiver designs were considered. The main difference between the three designs is the modulator/de-modulator design. The first method considered is a fully integrated transceiver circuit, such as the ADF7020-1 from Analog Devices [10]. This method uses a transceiver chip connected to external receive and transmit amplifiers and filters. All up and down-converting and signal modulation/de-modulation will be taken care of by the transceiver. Second, all modulation, de-modulation, mixing and amplifying will be done by discrete components. This transceiver is a simple FSK radio, where for example a Voltage Controlled X-tal Oscillator (VCXO) can do the modulation and demodulation can be done by a Phase Locked Loop (PLL). Third, a chip such as the CMX909B GMSK [11] modem together with a Microcontroller Unit (MCU) can take care of the modulation and de-modulation. Amplifiers and a up and down mixer will be required as external components.

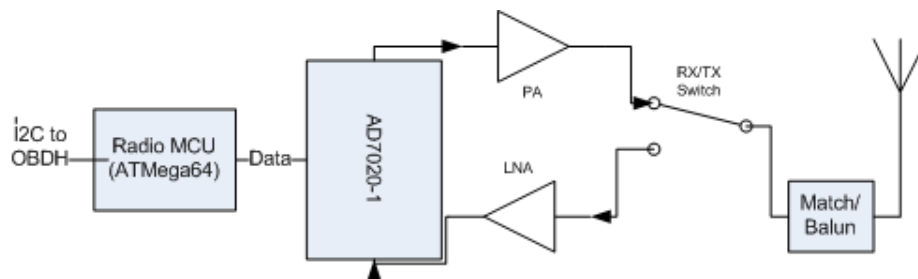

Figure 4.3: Conceptual schematic with ADF7020-1

The three different approaches all have their good and bad sides. The main advantage of choosing a fully of-the-shelf transceiver, shown in figure 4.3, is that after the, possibly extensive, configuration the radio is likely to work. It only requires a LNA and a PA and the RX/TX-switch. These components will be required by all three methods. On the other hand, such a component has several programmable registers, hence it can be prone to bit-flips. Since the device itself is not space qualified or Rad-Hard, high energy particle radiation can disable the device.

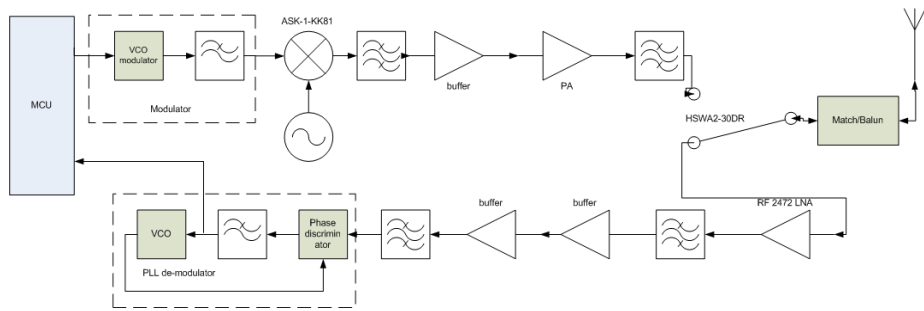

Figure 4.4: Conceptual Schematic, simple FSK

The second, and "simplest" solution, shown in figure 4.4, is to design a FSK radio using a VXCO for modulation and a PLL for de-modulation. Then most of the signal processing will be done by discrete components, may be less prone to radiation damage. A few disadvantages is obvious, bit-timing recovery has to be done by a MCU, as well as any FEC and interleaving functions. Choosing this method will need more firmware, in addition to more components.

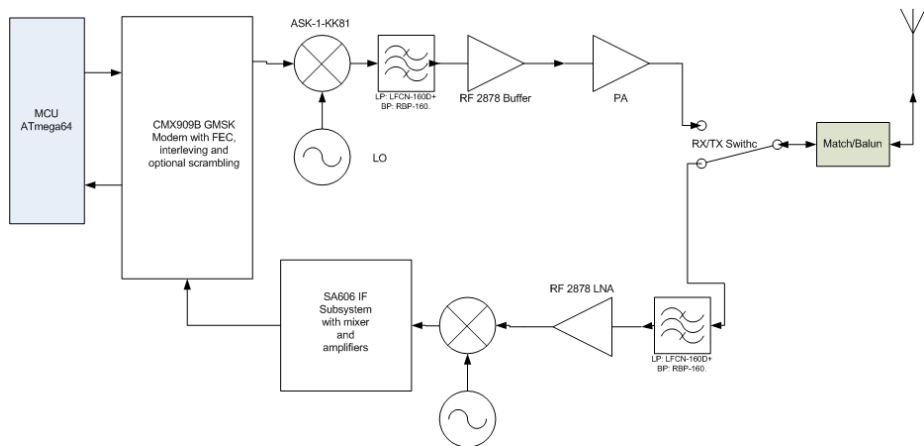

Figure 4.5: Conceptual schematic, GMSK-version

The last method, shown in figure 4.5 using a commercial GMSK packet radio modem will also be prone to radiation damages to some extent, but this solution adds a lot of functionality to the radio. The modem can implement FEC, scrambling and interleaving on the data packages. By choosing this solution, less digital signal processing has to be done by the MCU. The MCU is needed anyway for controlling the radio and modem, but the program can be kept as easy as possible.

Weighing all designs against each other, it can be hard to see one solution much better than the two other. The second one is the simplest, but gives the least functionality in regarding to digital signal processing. The other two are almost alike in that matter. The third solution needs more external electronics, but it will probably be easier to control noise properties. Noise properties, and noise bandwidth, for highly integrated components are not as good as for less

integrated components, but a good LNA must be used anyway, so noise properties will be possible to control. Another matter is the frequency generation. The Local Oscillator (LO) and channel oscillator must be very stable and controllable. This should be done in hardware. An integrated circuit might have only a discrete numbers of frequencies available. The third design is chosen, and will be further discussed in this report.

## 4.5 Selecting Components

Finding suitable components is a challenge. Several problem areas were soon evident; such as the LO-circuit, baseband recovery and LNA and PA. Power limits for both the transmitter and receiver will put stringent requirements for the components. After finding a few components for the receiver, it became clear that meeting the power limits would be hard when using discrete components. It also became clear that it would be hard to design a stable local oscillator. Two options were briefly discussed, the first is to get a custom made temperature compensated crystal, the second is a similar approach as done in the ncube project; using a MCU-controlled PLL for LO generation. This method could probably be the best one, but it was evident from [12] that the LO design had stability problems. Both those methods imposes a great deal of work, so it was decided to put that part of the radio system aside. For lab demonstration purposes, a good frequency generator can easily be used as LO.

## 4.6 Transmitter

In the chosen layout, a parallel data stream will be produced by the MCU, the data will be sent to the GMSK-modem that will implement FEC and interleaving on the resulting data package. A GMSK-signal from the modem will be mixed to the assigned carrier frequency, amplified and transmitted via the antenna.

Using the link budget and the conceptual schematic as a starting point, the design must be broken down into individual physical components. The main building blocks in figure 4.5, transmitter side, can be viewed as physical components.

Then, each component must be characterized, and component values must be found, such as gain, output power, operating frequencies and so on. Signal levels throughout the radio must be found, components must not be allowed to be driven outside their P1 point into saturation. An example of signal levels is found in figure 4.6. Note that loss (marked with red color) introduced in the signal path, assuming a wanted output power of 500 mW, will dissipate power in the order of 200 - 300 mW. In addition, as mentioned above, if the PA efficiency is poor, more gain must be introduced. Given 50% PA efficiency, the gain of the buffer must be doubled, then all passive losses will double, in addition to 500 mW loss in the PA. Current consumption in the active components also add in. To sum up; with total losses being doubled, 560 mW, adding 500 mW loss in the PA in addition to the resulting output level of about 500 mW. In total, 1.5 W might be needed to produce 500 mW output. Poor antenna efficiency will also contribute to a increased loss. Even if this is only half of the

Signal levels through receiver – Example

Worstcase -119 [dBW] -89 [dBm]  
 Bestcase -106 [dBW] -76 [dBm]  
 Z0 50 Ohm

Signal at...

Antenna		Connectors		LNA RF2472		Filter		SA606		
Input	Gain	Output	Gain	Output	Gain	Margin	Gain	Output	V out [mV]	
-89 [dBm]	2	-87	-2	-89	15	-74	-12	62	15	397,6E-1
-76 [dBm]	2	-74	-2	-76	15	-61	-12	49	28	177,6E+0

Worst case  
 Best case

Signal strength through transmitter – Example

Z0 50 Ohm

Signal at...

Mixer (0.5 V at LO)		Filter		Buffer		Filter		Power Amplifier		
Input [V]	Gain	Output	Gain	Output	Gain	Margin	Gain	Output	P1 Margin	
0,2	-0,97	-6	-1	-7,97	16	8,03	3,97	7,03	21	28,03
Loss [mW]	0,8	0,6	0,2	0,04	0,16	6,35	1,31	5,05	635,46	

Filter		Connectors		Switch HSWA2-30DR		Antenna		
Gain	Output	Gain	Output	Gain	Margin	EIRP [dBm]	EIRP [mW]	
-1	27,03	-1	26,03	-0,55	25,48	31	5,52	
130,7	504,77	103,82	400,95	47,69	353,26	2	27,48	
							Total loss [mW]	284,15

(a) Signal levels - receiver

(b) Signal levels - transmitter

Figure 4.6: Signal levels in signal path

allocated power in the power budget, it will impose a problem with heat dissipation. Especially it is important to ensure cooling of the power amplifier. Since there will be no convection in space, the heat must be lead to the satellite surface by heat conducting materials. This heat can also be used to keep the battery bank warm. Anyway, the transmitter will not be active for more than a few minutes at the time so the problem should be possible to solve.

#### 4.6.1 Filters

One or two transmit filters might be used, only one shown in figure 4.5. If necessary, a filter can be but in after the PA. This is not ideal, since this filter will dissipate much power. In the signal level example above, a filter is in place after the PA. It is seen that if this filter is removed, about 130 mW will be saved.

Since the operating frequency is quite low, it was decided to use low-pass filters instead of bandpass filters on the RF side. The reason being the low-pass filters is only a fraction of the size of a bandpass filter, in addition they are cheaper. The filter decided upon is the LFCN-160D from Mini Circuits. See data sheet [13].

#### 4.6.2 Mixer

The mixer chosen is the ASK-KK81 from Mini Circuits. See data sheet [14]. This mixer requires about +7 dBm LO drive, and gives a stated conversion loss of about 5.1 dB at 145 MHz.

#### 4.6.3 Buffers and Power Amplifier

It has been discussed to use the RF5110G Tetra amplifier as power amplifier and RF2878 as buffer. The RF5110G has a stated efficiency of only 45% at 145 MHz [15]. This is too low, as shown above the power loss will be huge. No other good alternative has been found at the time of writing, but it is planned by the Radio Group at the Department of Electronics and Telecommunications (IET) to give a student assignment to design and manufacture an amplifier for this use. Because of this, no further work regarding the transmitter has been carried out.

### 4.7 Receiver

The signal from the antenna will be amplified by a low noise amplifier, before being mixed down to baseband before the GMSK-modem demodulates the signal. The resulting data stream will the be read to the MCU.

As shown in the theory, it is important to minimize losses in front of the LNA. Some losses will be present, in antenna connection and cable. The input filter is probably necessary to remove any power coming from the 437 MHz link. After brief measurements of the proposed antenna, it was seen that the 145 MHz antenna has a resonance about at UHF frequencies<sup>1</sup>. at about 430 MHz.

---

<sup>1</sup>The antenna measurements are not a part of this report, but that result is worth mentioning

Figure 4.6 also show an example of how signal levels can be throughout the receiver. Two cases are presented; best and worst case from the link budgets. It is seen that only a moderate LNA gain is needed. The SA606 is stated to detect power levels as low as -118 dBm [16], so in theory, a LNA is not needed at all, but it will help the noise properties of the total receiver. In the link budget, the overall system noise temperature is calculated only including losses in front of LNA and the LNA itself. It can easily be shown that further elements, such as the SA606 only will increase the noise factor with about 0.1 or 0.2 dB.

### VHF and IF Filters

The same filter as used in the transmitter will be used before the LNA. Between the mixer and the SA606, the PIF-40 [17] filter from Mini Circuits will be used. The IF-filters used together with the SA606 are discussed below.

### LNA

The RF2472 or the RF2878 are proposed as LNA. See measurement results in chapter 6. Both have good noise figures of about 1.5 dB and a gain in the order of 25 dB, as observed from data sheets [18, 19].

## 4.7.1 IF Subsystem

Since the allowed power consumption for the receiver is set quite low, using many separate components for the IF-stage will consume too much power. Therefore an integrated IF subsystem, SA606 from NXP, was found. This circuit consumes only about 3.5 mA, much the same as separate mixers, buffers and PLLs would use each. This is the same circuit as used in ncube. The advantages of using an integrated circuit are reduced area and easier design, in addition to reduced power consumption.

The use of this circuit also solves another issue, the Doppler shift. The VHF-band will only experience a small Doppler shift, but it must be taken into account anyway. The SA606 converts the IF-signal to baseband in a such way that Doppler shift can be neglected; it uses the detected carrier in the IF-signal as LO for its second mixing stage. As long as the Doppler shift is small, about  $\pm 3$  kHz as found in the pre-study [1], the resulting frequency will not fall outside the IF-filter bandwidth.

An other feature added by a system like this is high gain. A level in the magnitude of one volt must be present at the GMSK modem input. From a low input signal at the antenna, a gain about 100 dB has to be implemented. The SA606 sub-system itself will yield about 90 dB. This could be difficult to achieve with separate buffers and op-amps within the assigned power limit.

The SA606 and other circuits in its family was the only circuits found for this use, apart from an obsolete similar system from Motorola, that Freescale, Motorolas successor, not has put in their product range.

### Operation

The SA606 pre-amplifies a differential input signal before it is mixed by a Gilbert-cell mixer down to 445 kHz. The signal is then amplified and filtered

in two stages. The last stage is a limiter creating a clipped signal containing the phase information. In the last mixing stage, a recovered carrier signal is used as LO to mix the 445 kHz signal down to baseband. The block diagram is shown in figure 4.7. External components are not shown.

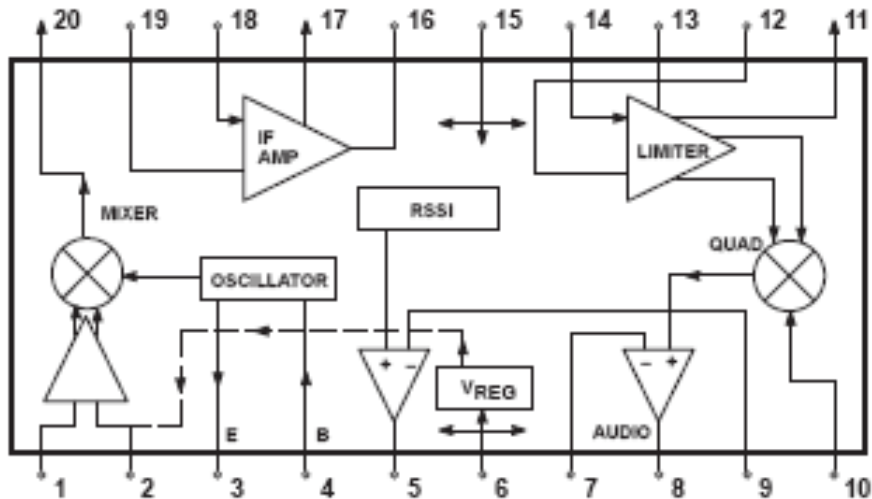

Figure 4.7: SA606 block diagram. Source: [16]

The SA606 can be used in several configurations, the chosen one is 45 MHz RF and 445 kHz IF, but direct conversion from 145 MHz to e.g. the 10.7 MHz standard IF could also be used. This would be desirable if a wider bandwidth is needed, and to save a mixing stage.

### 4.7.2 Digital Signal Processing

The digital side of the radio is taken care of by two main components, the GMSK modem and the MCU. Because of the GMSK modem, less work has to be done by the MCU. Its purpose will be setting up and controlling the modem and the RX/TX processes. The can modem implement signal processing such as FEC, scrambling and interleaving. In addition, the modem is taking care of bit timing recovery and bit detection, releasing the MCU from this task.

#### GMSK Modem

The GMSK-modem [11] is a fully integrated baseband processor. The modem operates on the Mobitex package format, adding features such as FEC/CRC, interleaving and optional scrambling. The modem is capable of a wide range of bit-rates, the chosen one is 9600 bps. This gives a reasonable used bandwidth within the allocated 25 kHz. One Mobitex frame includes 7 bytes of frame head, a block of 18 bytes of data together with 4 FEC bits for each byte, and a hang-byte. This gives  $56+216+8=280$  bits pr. frame, where 144 bit are data bits. The usable bit rate will then be 4937 bps. It is possible to wrap 32 data blocks inside one frame, hence improving the usable bit rate somewhat.

## MCU

The MCUs job is to control the GMSK-modem. The components interface is two 8-bit wide ports; one for parallel data the second for controll signals<sup>2</sup>. In addition, the MCU must be able to communicate with the satellite main data bus, memory and control unit. Lastly, the MCU will be used to control the whole radio system, so it must provide control signals for controlling amplifiers and the switch.

In the future, the MCU should be equipped with a boot loader feature, so it can be reset and re-programmed by the main onboard computer in the case of a memory or program error.

ATmega64 was chosen for this purpose. This is a 8-bit AVR microcontroller from Atmel, capable of running at 8 MHz on internal oscillator.

The AVR series has several supporting tools such as the STK500 development board [see 20], a Gnu GCC compiler [see 21] and a lot of online recourses. The microcontroller is very easy to get started with, and is familiar to a number of students. Atmel also allow a student workshop at NTNU, Omega Verksted, to supply students with cheap microcontrollers and tools for student projects. Low voltage operation (3 V) is supported, and power consumption is fairly low, the device itself needs about 2 mA [see 22] to operate, in addition to power delivered to external components, sourced by the microcontroller. Since the AVR is easy to get hold of, and is a known platform, this was decided for prototyping. Other microcontrollers like Phillips and ARM could be used, but they are to the authors knowledge more complicated to get started with, so they were not evaluated in any way. The reason ATmega64 was chosen was because of the number of external ports in comparison to most other AVR devices. If boot-loading and reconfiguring are to be implemented on a later stage, some data pins should be reserved for this purpose. The same accounts for the MCUs I2C bus. A controller with six 8-bit ports have plenty of I/O recourses available, so needed functionality to operate the radio system can be assigned to one single MCU.

## Modulation Method

As shown in chapter 3, a few modulation methods where briefly discussed. Because of the functional GMSK-modem, GMSK was naturally chosen. This was the only component found with this much functionality, and capable of a bit rate over 4200 bps, aside from a fully integrated transceiver. Ordinary FSK could be a better choice, the Gaussian filtering in GMSK implies inter symbol interference. Ordinary FSK use more bandwidth, but would be easier to demodulate, as discussed in [23].

## 4.8 RX/TX Switch and Antenna Connection

Because this design is a single-frequency system, a RX/TX-switch (or similar working device) must be implemented at the antenna. This imposes some critical issues. The switch must not be able to reach a un-defined, not connected state and it must not be able to permanently lock t o either the transmitter or

---

<sup>2</sup>Not all 8 pins are used



#### 4.8. RX/TX SWITCH AND ANTENNA CONNECTION

---

receiver. In addition, the switch will add loss to the system; compromising the signal-to-noise ration on receive and dissipate much effect on transmit. The magnitude and impact of these losses must be controlled to see if they can be allowed. Generally, a RX/TX switch add losses on the worst location.

The switch should be controlled so its default position is receive, transmission only enabled when the power amplifier is active.

There are methods of elaborate impedance matching techniques, where the goal is to match the LNA to be seen as a total reflection for a signal coming from the PA, and vise versa when in receive modus.

At higher frequencies, a circulator could be used, but the size of a circulator is proportional with the signal wave length, hence it will be too large for this application.

Important parameters is insertion loss and isolation between the ports. Other issues regarding antenna connection is beyond the scope of this assignment.

Two switches were considered on the early design stage, one from Mini-Circuits, the HSWA-2 and a rad-hard space qualified switch from Peregrine Semiconductor. Since the HSWA-2 was the easiest to get from a supplier, this was chosen to work with on this stage.

## Chapter 5

# Actual Construction

To better be able to evaluate and test all major components, it was decided to design and assemble several evaluation boards for components as the IF subsystem, the LNA, PA and modem. The purpose was to test each component individually and evaluate if the components fulfill the requirements and better understand how to tune them for best performance. Some of the lab work was done together with Erik Narverud.

### 5.1 Prototypes and Evaluation Boards

For PCB design, the free program CadSoft EAGLE 4.16r2 Light Edition was used. The program is capable of designing two sided circuit boards, 8 x 10 cm in dimension. The Radio Group has a LPKF Protomat S100 Circuit Board Plotter used for prototyping instead of etching. The two main advantages to use milling instead of etching are automatic alignment of the two layers and the miller is capable of drilling holes for vias and components automatic. The disadvantages are the setup and production time, as well as the problem to define narrow gaps between conducting lines. The most narrow opening is naturally controlled by how wide the milling tool is. The miller features a multi-width conical tool, 0.2 mm to 1.5 mm wide. If it is not mounted correctly, the tool can have a deeper work depth than it should, hence the gap between lines will be wider than specified. This can provide a problem with the small component packages, as used in this project. Thinner one-size tools can be used, but they are very fragile and are much more prone to breaking.

Not all used components came in packages known by Eagle, so a few packages had to be drawn by hand, or by extending and adapting known packages and footprints. This includes packages for the SA606, the mixer, the switch, the LNAs and the GMSK-modem. The library file will be uploaded to the projects web archive. All Eagle project files also will be accessible there.

#### 5.1.1 IF-subsystem - SA606

The evaluation board is based upon an example in the data sheet [16], see figure 5.2, with a few modifications. SMA-connectors were added at each IF-amplifier output and at the mixer output for easier de-bugging possibilities.



**Figure 5.1:** Protomat circuit board plotter

Final schematic is seen in figure 5.3. Board outline can be found in appendix A.

A few modifications were done during the testing phase, final layout shown in figure 5.3. While doing measurements, a possible flaw in the reference design was noted by guidance teacher Morten Olavsbråten. In the proposed design, the feed-back network at the output amplifier will amplify higher frequencies more than low, which is not desirable. In figure 5.2 R10 and C27 are placed in series, they should be placed in parallel as in figure 5.3. To get an additional smoother output signal, a capacitance was placed parallel to ground on the output pin. On the input side, a balun transformer is placed between the input SMA-connector to the SA606 differential input. The original input network design will also function.

The changes above was not, to the authors knowledge, present in the ncube designs.

### **IF-filters**

The IF filters used is not exactly the same Murata filters as the one proposed in the data sheet. The ones used, have input impedance of  $3000\ \Omega$  instead of  $1500\ \Omega$ . Some degradation in operation must be expected, but at so low frequencies there should be not too big issues. The bandwidth properties are the same. The filters are of the Murata SFU455A type, see product information at Elfa.se [24].

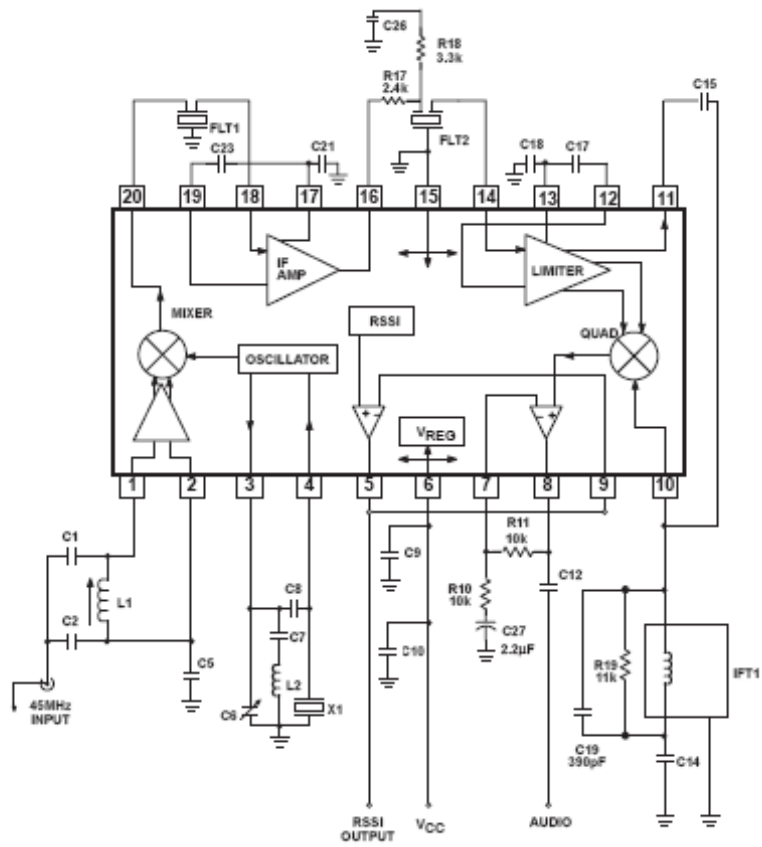

Figure 5.2: SA606 evaluation board. Source: [16]

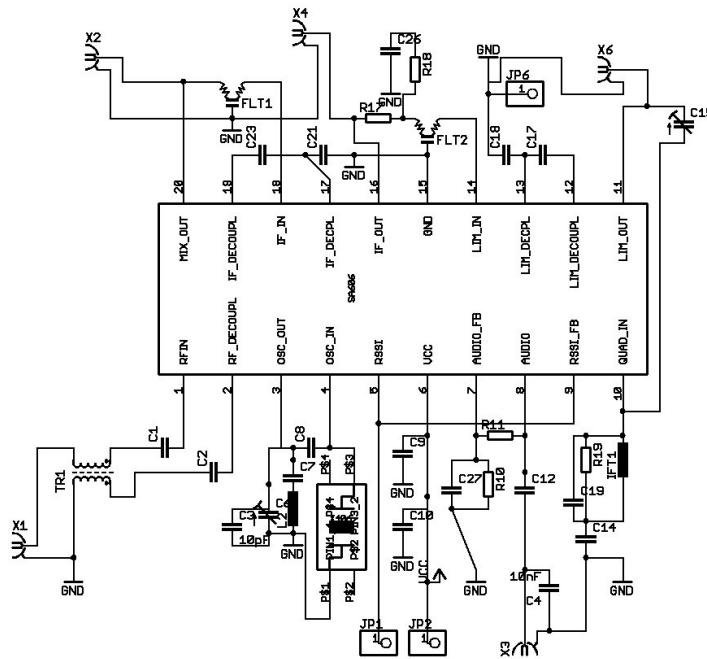

Figure 5.3: SA606 Schematic, version 2

### 5.1.2 LNA - RF2472

A evaluation board was made based on schematic in the data sheet [18] and with support in the work done by Log in [12]. A new and resulting schematic is seen in 5.4. Not all component pads are used; L4 and L2 are just used to make pads for potential necessary matching components, as well L1. A good few combinations of matching networks was tried, and several matching methods was tried. The final versions component values are shown in table E.1.

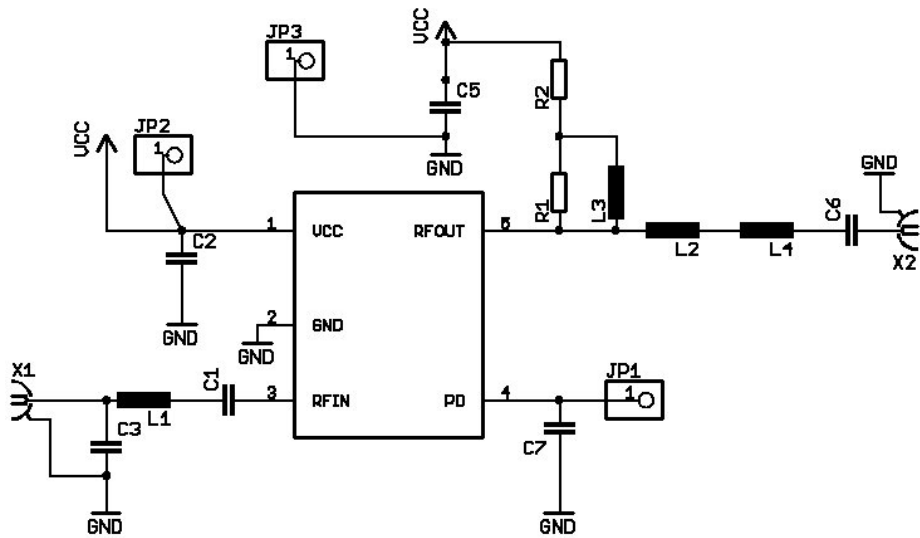

Figure 5.4: RF2072 schematic

### 5.1.3 Mixer - ASK-1

Figure 5.5 shows schematic developed from the data sheet [14]. No external components are needed. Note that a ground plane under the mixer is recommended for good operation.

See appendix B for evaluation board outline.

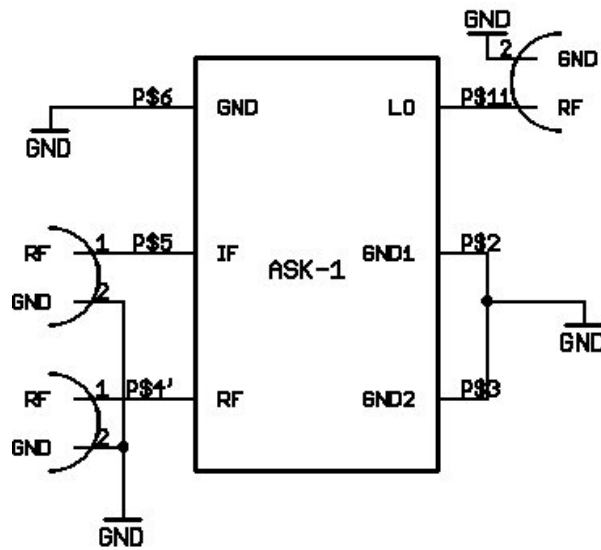

Figure 5.5: ASK-1 Mixer, schematic

#### 5.1.4 Low pass filter - LFCN160

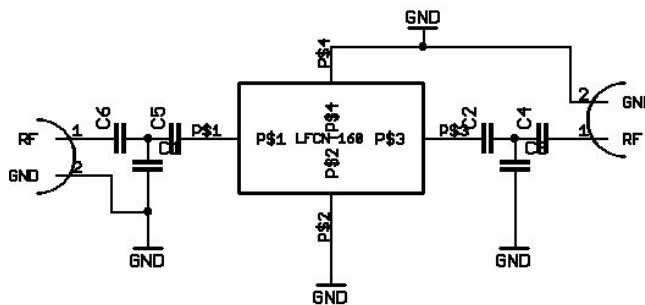

Figure 5.6: LFCN-160 evaluation board

Figure 5.6 shows an evaluation board for this filter. None of the external components (C1 to C6) are used.

#### 5.1.5 GMSK-modem - CMX909B

Based upon instructions in the data sheet [11], an evaluation board was designed, as shown in figure 5.7. In the figure, note that R5 is put there to, in combination with R1, easier control the total resistance in the input feedback network. Also, note that the output pins 18 and 19 not should be connected to the microcontroller; they are for the modems internal use only, that should be changed in further revisions of this board, or in a real application circuit.

When ordering this component, a mix up regarding to the package type occurred. The package delivered is the largest one, not usable in a final design as it consumes too much area, a smaller package must be used.

To easier do initial programming, debugging and testing header connectors for connection to a microcontroller are used. This way, an external microcontroller can be connected without having to solder the microcontroller. The ATmega64 can be programmed when placed on the Atmel STK500/501 development board. The STK500/501 provides several auxiliary functions, as changing oscillator source, component voltages and such. The STK500/501 also allows easy connection to the Atmel JTAG ICE mk II debugger.

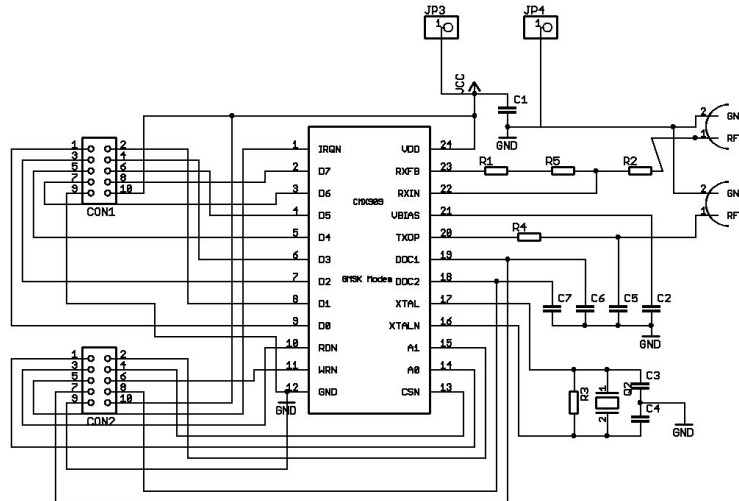

Figure 5.7: CMX909 schematic

See appendix H for components and board layout.

### 5.1.6 Switch - HSWA-2

Figure 5.8 shows schematic based on the data sheet [25]. None of the pads for inductors and capacitors are used. See appendix F for board layout. Since the rest of the radio system was not finished completely, the switch was not tested much, and it will not be further discussed.



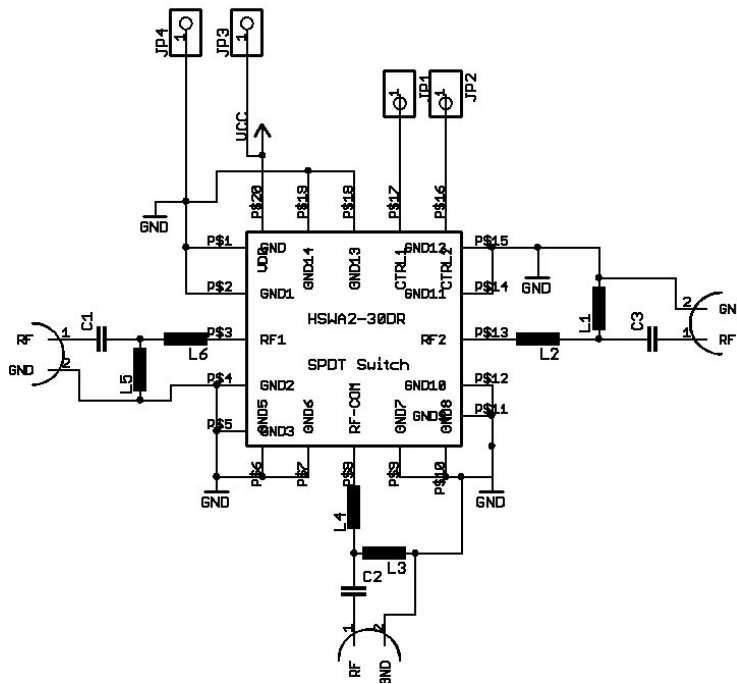

Figure 5.8: HSWA-2 Schematic

## 5.2 Digital Signal Processing

### 5.2.1 GMSK Modem

The CMX909B is a fairly easy device to operate with a microcontroller. It has several defined tasks to be used when transmitting or receiving a signal. The microcontroller's task is to command the modem to operate those tasks on provided data. Timing constraints are quite easy, as the device features parallel data communication with the MCU, and the bit-rate is low in comparison to the MCU's frequency at 8 MHz. In the current configuration, the modem itself runs on a 4.9 MHz crystal.

#### Register Overview

The modem features four writable registers and three readable registers. They are addressed by setting the two address-select bits, together with read or write operation. The data buffer is read/write, command register, control register and mode register are writable, status register and data quality register are readable.

The data buffer is used both for receiving and transmitting data. The buffer is 18 bytes wide, one byte being read or written during one read or write operation. This allows asynchronous operation; the MCU is allowed to use several clock periods between read or write operations.

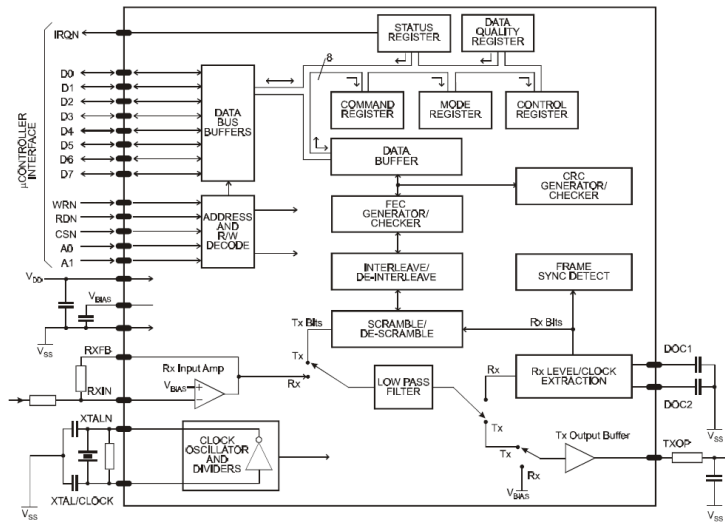

Figure 5.9: CMX909 block diagram

### Operation and Functions

When starting a transmit sequence, the microcontroller must set up the modem each time, i.e define the correct data rate, enable/disable scrambler and so on. Then, each byte of the frame head is loaded to the data buffer. When the modem is ready the 18 bytes of data (standard package format) are loaded to the data buffer. The modem performs FEC-coding and interleaving and the microcontroller assigns the send command. The modem is controlled by setting the mode and control registers and by assigning correct tasks to the command register. Task overview is found in the data sheet [11].

To enter receive mode, the microcontroller must set the data rate and other parameters, enable receiving and tell the modem to look for a frame head. Then, the modem will detect the inbound signal by measuring received signal strength and then start to look for sync words in frame head. When a frame head is successfully detected, the modem will read the next bytes, de-interleave the data and check FEC. When data is ready to be read from the data buffer, the modem will set a control bit in the status register, so the microcontroller can read the received data.

The modem is capable of data rates between 4000 bps up to 32000 bps depending upon the crystal frequency and internal clock divider. As known, 9600 bps will be used in this configuration.

### 5.2.2 MCU Software

The MCU software is written using Atmel AVR Studio and the WinAVR GCC compiler. Functions for setting up the modem for transmission and reception has been developed, based on proposed float diagrams in the CMX909B data sheet [11]. The source code is found in appendix H.3.

## Chapter 6

# Measurements and Evaluation

This chapter describes test set-up, measurements and results from component testing. Measurements will be briefly discussed in regarding to each component.

### 6.1 Test Equipment

The equipment used to test and measure are listed in 6.1.

Instrument	Function
HP 33120A	15 MHz Function Generator
HP 83752A	0.01 - 20 GHz Syntisized Sweeper
HP Infinium	1.5 GHz Oscilloscope
Rohde & Schwartz FSQ40	Signal Analyzer
Rohde & Schwartz SMU200A	Vector Signal Generator
Rohde & Schwartz FSEA	20 Hz - 3.5 GHz Spectrum Analyzer
Agilent E8364B PNA	10 MHz - 50 GHz Vector Network Analyzer
HP 165000	Logic Analysis System Mainframe

**Table 6.1:** Test Equipment

It was noted when arranging the test equipment for the mixer and SA606 test, that the FSQ40 signal analyzer did display a 3 dB higher power level than the vector signal analyzer (VSG) was stating. The output level from the VSG was then measured with two other spectrum analyzers, giving a reading near the stated level from the generator. The output level from the HP 83752A was also checked, showing the same relation; the signal analyzer (R & S FSQ) giving a readout a good 3 dB over the frequency generators stated own level, and the level measured with the spectrum analyzer (R & S FSEA). The reason for this was not found, so the Rohde & Schwartz FSQ40 Signal Analyzer was replaced with Rohde & Schwartz FSEA 20 Hz - 3.5 GHz Spectrum Analyzer for all other measurements.

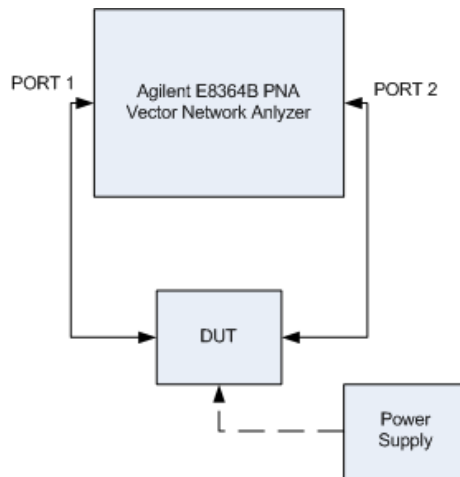

Figure 6.1: Test Setup - Network Analyzer

### 6.1.1 Test Setup - Network Analyzer

Figure 6.1 shows test setup for measurements with the Agilent PNA network analyzer. The device under test (DUT) is connected with coaxial cables to the PNA ports. The power supply is used only for active components, such as amplifiers. This test setup is the same for all tests. The network analyzer records S-parameters for a selected frequency span and displays this on screen. The results can be saved as pictures or they can be exported to a format readable by network simulation programs such as Agilent Advanced Design System, ADS.

## 6.2 LNA - RF2472

It was soon evident that it would be difficult to find a good impedance match for RF2472 at VHF frequencies. The input and output impedance varies over a large interval with frequency, hence a correct match will be difficult to achieve with physical, non-ideal components. Several iterations with different component values on the evaluation board was tried, without finding a good match for both S11 and S22.

It is seen from figure 6.2 that even if S22 has not a good match, amplification is still within the specifications in the data sheet. Looking only at S11 and amplification, this is a good result, but since S22 is not good, the set-up should not be used.

After extensive testing, RF Micro Devices, the manufacturer, was contacted. As seen in chapter E.4, RFMD does not recommend this amplifier in the VHF-band. Therefore, even if S22 could have been matched better with an attenuation pad, it is decided not to use RF2472 in measurements involving other components.

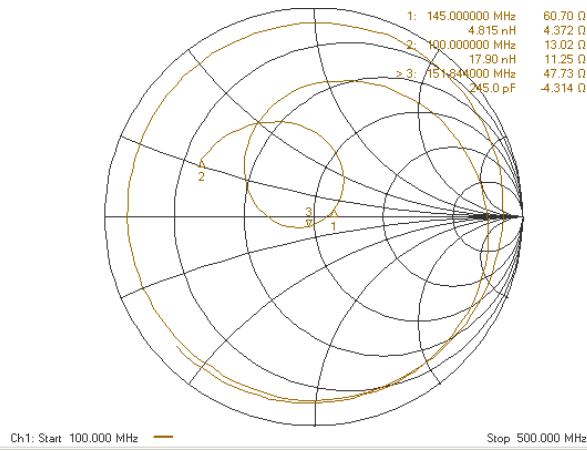

(a) S11

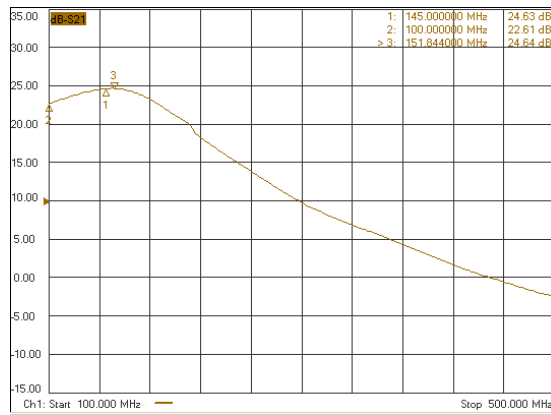

(b) S21

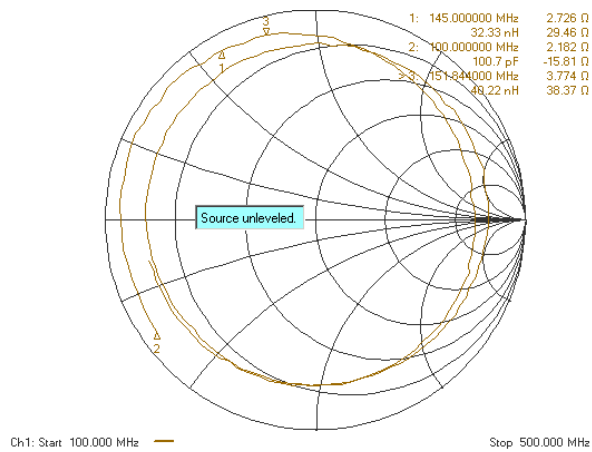

(c) S22

Figure 6.2: PNA-results for RF2472

### 6.3 RF2878 - Simulation

For simulating circuits, Agilent Advanced Design System, ADS was used. This program is a extensive design program, it can be used to simulate and optimize electrical circuits and RF systems. It is possible to get S-parameter models from different circuit manufactures, load the model into ADS and experiment with matching networks etc. Network analyzers can also export this file format, this feature was used when analyzing measurements of the LFCN-160 filter.

#### 6.3.1 Results

Because of the problems with RF2472, the RF2878 was studied and simulated with ADS. 2-port S-parameter files was received from RFMD, and ADS was used to simulate several matching networks. It was found that also the RF2878 is hard to match to  $50 \Omega$  at 145 MHz.

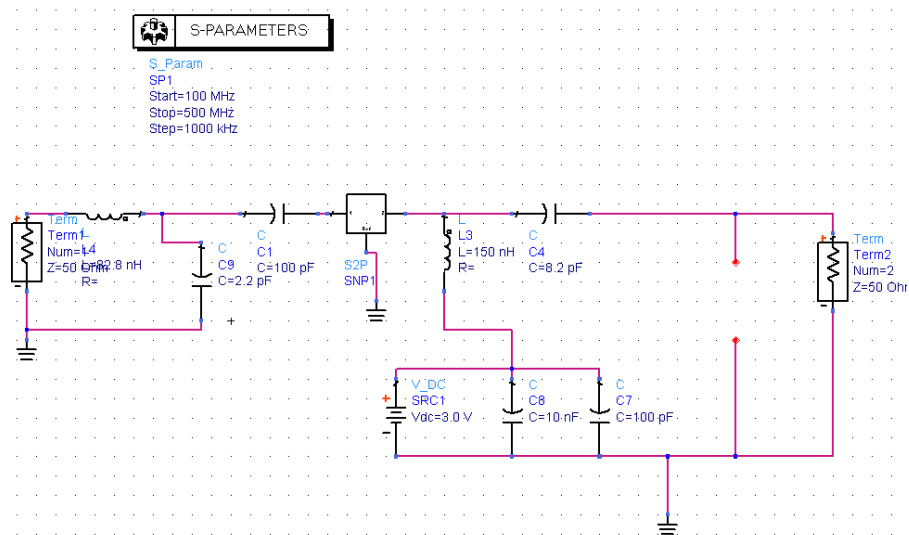

Figure 6.3: Schematic, good match for S11

RFMD proposes in the data sheet [19] a layout similar to the one in figure 6.3. Using ADS and the tuning feature, the relationship between the components is found. It seems like the inductor L3 scales the matching point with frequency together with C4. When increasing C4, the circuit becomes more stable regarding to how much the curve walks in the Smith-diagram. It is found that the components on the input side has very little to do with the matching, this will be shown. Figure 6.4 shows the resulting S-parameter values. S11 has a good match; return loss of 31.6 dB and amplification is good. It is seen that it is some distance between the gain maximum and the S11 minimum the circuit in figure 6.3 is a reasonable trade-off. But it is also seen that S22 has a bad match, so the configuration is not good.

Figure 6.5 shows a layout when S22 has good match, as shown in figure 6.6. Note that only two components differ between this layout and the previous one. Still, the matching result is completely different. This means the

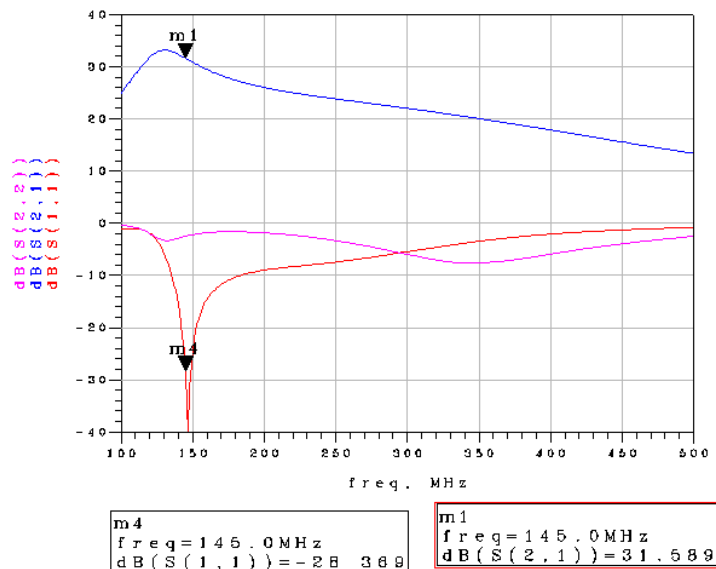

Figure 6.4: S11 match, logarithmic

input impedance is highly dependent upon the output network. MiniCircuits has defined a term called *Active Directivity*, defining how isolated the input impedance is from the output impedance. This is defined as  $S_{21}$  [dB] +  $S_{12}$  [dB]. If the number is high, source has a good isolation from the input and vice versa. It is seen from the simulations in figure 6.8 that the active directivity for RF2878 is only a few dB, hence the input impedance will be greatly affected by the output [26].

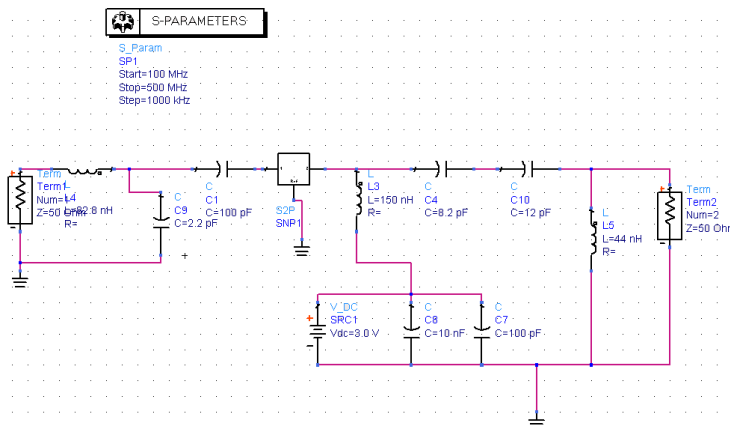

Figure 6.5: Schematic, good match for S22

ADS features an optimization tool, which "randomly" assigns component values within user-defined limits and tries to find the best combination com-

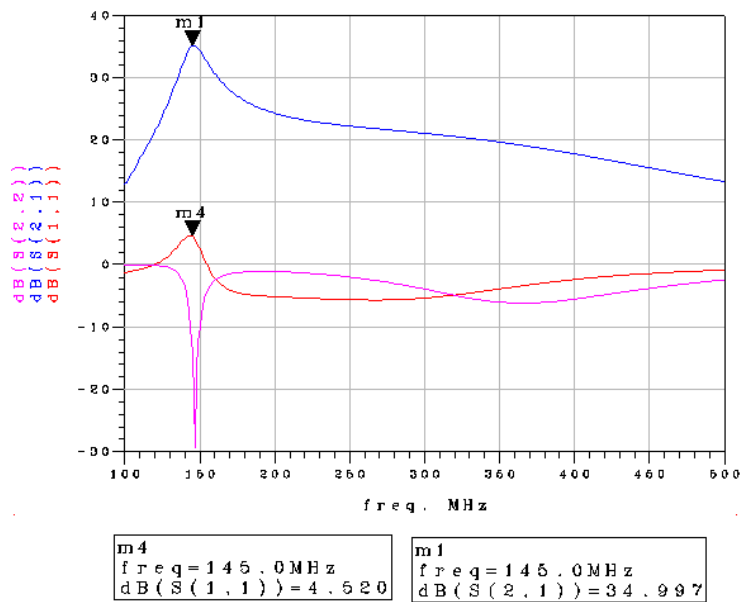

Figure 6.6: S22 match, logarithmic

pared to a desired simulation result. When setting optimization goals to minimize S11 and S22 ADS found the solution in figure 6.7. Several input and output networks were tried, all of them yielding more or less the same result as the mentioned schematic.

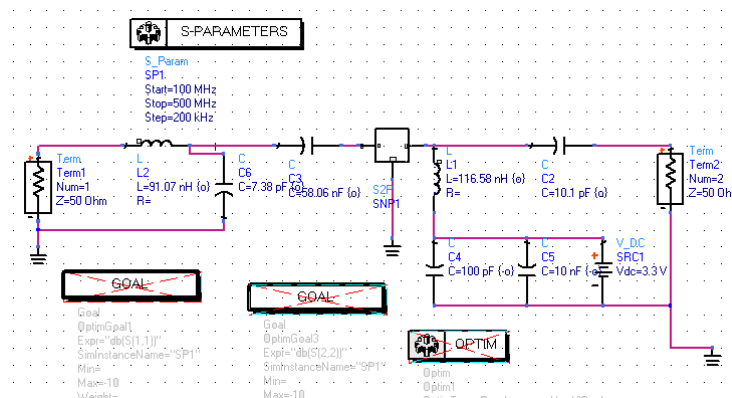

Figure 6.7: ADS optimized circuit

The result is shown in figure 6.8. The result is not very good. It is seen that the gain is very near the simulated maximum gain, but neither S11 nor S22 features a good match. An amplifier should have a return loss better than 10 dB, at least. It is possible to achieve a better match if attenuation pads are used. But that method compromises power. The best solution will be to look for a more suitable product, that could be a challenge, none better has been found



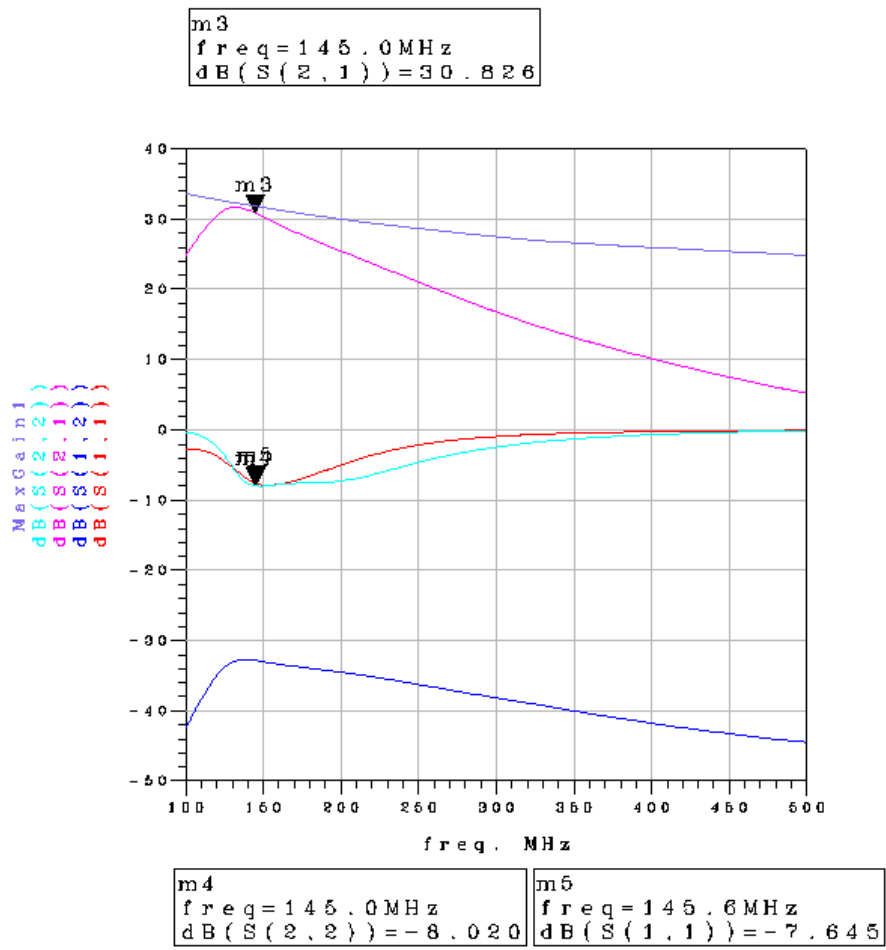

Figure 6.8: ADS optimization

during the project work. Smith diagrams for the examples discussed above is found in appendix G.

## 6.4 Mixer - ASK-1

As up- and down converter it was decided to use the ASK-1 mixer from Mini-Circuits [14]. A frequency mixer with two input ports, LO and RF, will generate frequency components at the output, IF, port with this relation:  $f_{IFa} = f_{RF} + f_{LO}$  and  $f_{IFb} = f_{RF} - f_{LO}$ . Hence, there are two possibilities to investigate, both for up- and down convention. Both possibilities will be examined to check if one of the combinations is the better. Larger distance between the two frequencies are desirable to ease filtering.

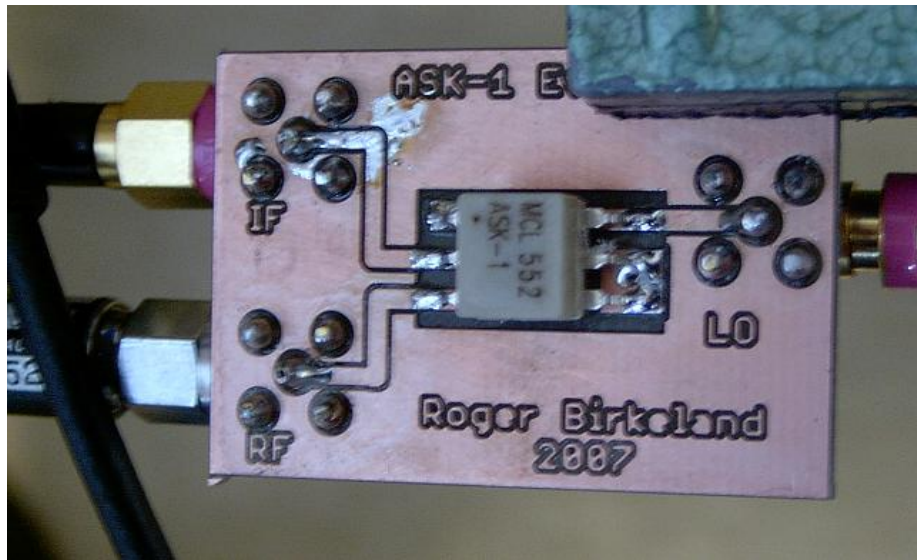

Figure 6.9: Mixer under test

Other spectral components present will be LO leakage and harmonics. The mixer has a stated isolation of about 30 dB between the LO port and the RF/IF ports. In addition, the lab is in a very noisy environment, other signals such as other experiments, commercial radio- and TV stations and radar systems can cause interference and spurious signals if injected into the circuit through the mixer.

### 6.4.1 Down converter

Since RF is 145 MHz and desired IF is 45 MHz, the two alternatives is  $f_{LO} = 100$  MHz and  $f_{LO} = 190$  MHz.

Figure 6.10 shows test setup. For each LO frequency, there are one test with and one test without the filter.

Unfiltered output spectrum from the mixer is shown in figure 6.11 for 100 MHz LO and in figure 6.12 for 190 MHz LO.

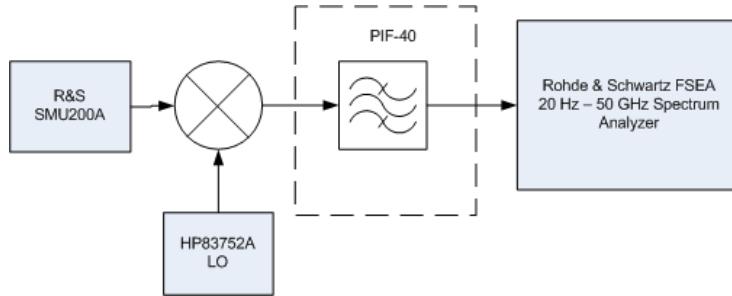

Figure 6.10: Test setup, mixer

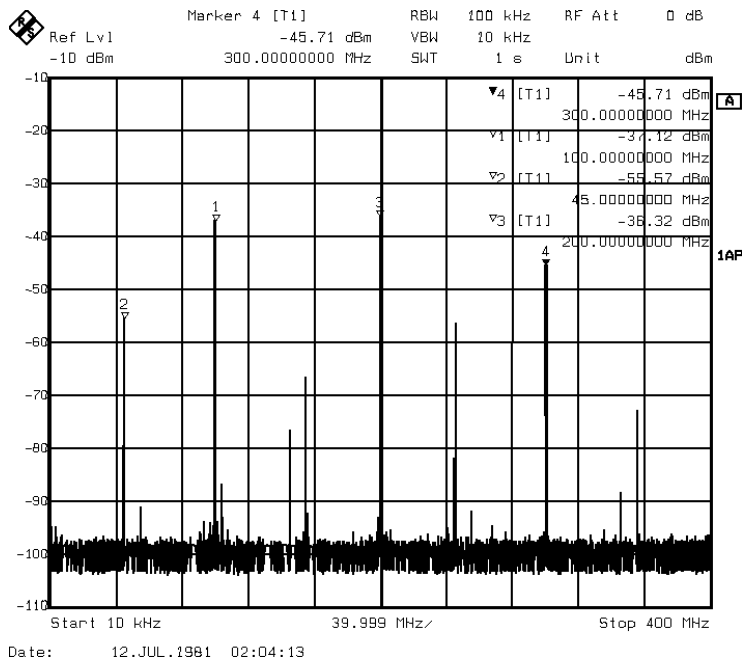

Figure 6.11: Mixer output with 100 MHz LO, +7 dBm, RF level at 50 dBm

It is seen from the figures 6.11 and 6.12 that the spectrum when the LO is 190 MHz is cleaner. (Note that the RF input level is not the same). The components present in the spectrum is mainly the desired signal (marker 2), LO leakage attenuated about 40 dB (marker 3), the second IF frequency (marker 4) and the original RF signal (marker 1). Right of marker 4 a significant amount of the LO second harmonic is shown.

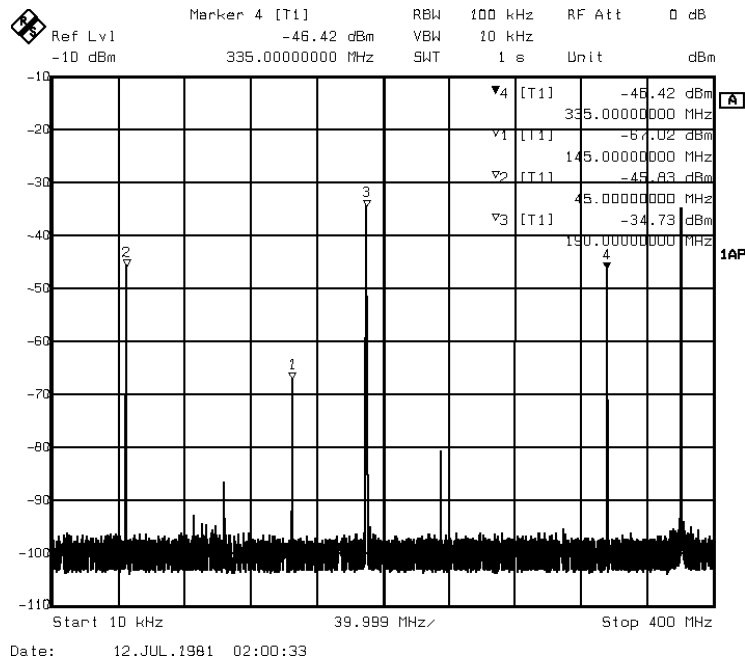

Figure 6.12: Mixer output with 190 MHz LO, +7 dBm, RF level at 40 dBm

Filtered output, through PIF-40, are shown in figures B.4 for LO at 190 MHz and figure B.3 for LO at 10 MHz in appendix.

It is observed that the mixer is giving a (unfiltered) conversion loss of about between 5.5 dB and 5.8 dB. The filter seems to have a insertion loss of about 1 dB. This is stated in the data sheet [17] to be about 0.3 dB, which coincide with network analyzer measurements shown in figure C.1 and figure C.2

Since the spectrum from LO at 190 MHz is cleaner (got fewer and smaller spurious components) this is chosen as LO frequency. Also, this yields the bigger separation between the frequency components; hence the leakage and the upper band will be more attenuated in this configuration.

The conversion loss of the mixer within the range stated in the data sheet [14]. Even if not separately measured, the insertion loss of the filter seems to be a bit larger than stated in the data sheet, [17] and earlier measurements. This could also be explained as loss in cables and connectors.

## 6.5 Low pass filter - LFCN160

After measuring S-parameters with the PNA and analyzing the results with Agilent Advanced Design System (ADS), it was found that the cut-off fre-

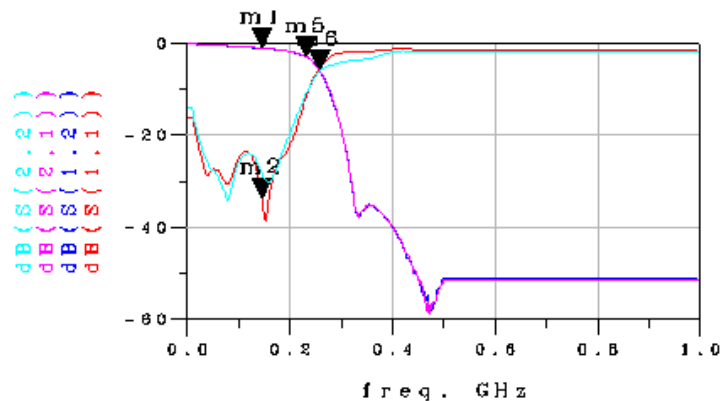

**Figure 6.13:** S-parameters for LFCN-160. M1 is at 145 MHz in passband for S21, M2 is at 145 MHz for S11, M3 is 3 dB cut-off at 233 MHz, M4 is at -6 dB at 258 MHz.

frequency of this filter might be too high. The LFCN-120 could probably be used without losing too much power to higher insertion loss. Regarding to the data sheet for LFCN-120 [27], the insertion loss at 150 MHz is 1.18 dB. Stated insertion loss for LFCN-160 is 0.77 dB [13].

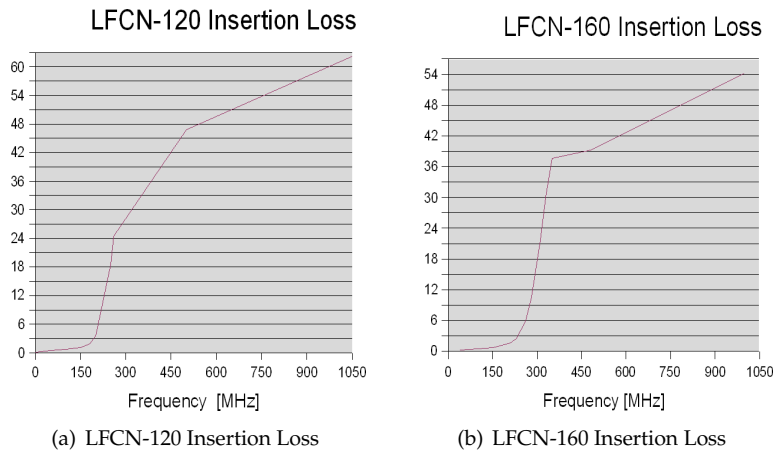

**Figure 6.14:** LFCN-120 and LFCN-160 Insertion Loss. The graph shows the given insertion loss values from the data sheets [27] and [13]

Figure 6.14 shows insertion loss for both filters (from data sheets), showing similar properties in passband, but LFCN-120 achieves better out-of-band results sooner than LFCN-160 and should maybe be used in this application. At 260 MHz the insertion loss is 24.46 dB, for LFCN-160 the insertion loss is only 5.92. Anyway, it should be noted that this increased insertion loss is introduced at the worst possible place in the circuit, before the LNA. The choice of filters will be a trade-off between in-band and out-of-band properties and must probably be postponed until all noise properties are measured and known.

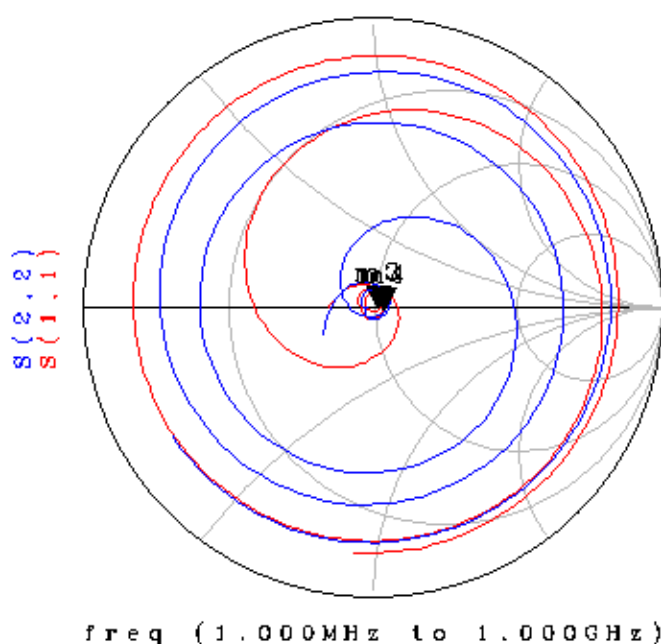

Figure 6.15: Smith-chart for LFCN-160. Markers are at 145 MHz.

Figure 6.13 shows the measured data plotted by ADS. Marker 1 shows insertion loss at the 145 MHz passband frequency, marker 2 shows the return loss at the same frequency. It is seen from the plot that the passband, insertion loss less than 3 dB, extends almost 100 MHz from the passband. Therefore, a filter with lower cut-off frequency might be desirable.

Figure 6.15 shows impedance match plot in Smith chart for S11 and S22. See appendix D for more figures.

## 6.6 IF Subsystem - SA606

Several tests were conducted, to verify SA606 operation. At the first test,  $V_{CC} = 6$  V and a 10 kHz FM modulated RF signal was applied. No output signal was detected on the data output. Using an oscilloscope, the outputs of the different components of the SA606 was measured. No useful signal was found; the output of the first mixer stage seemed to be an offset DC level at about 1.7 V. An input signal was found present at the input pin, and the oscillator seemed to work fine when probed. Even so, the mixer gave no output.

It was then decided to apply a 455 kHz modulated signal to the IF amplifier to check the rest of the circuit. A very noisy signal was present at the output, see figure 6.16.

After more extensive checking, it was found that if pin 3 (oscillator out) at the SA606 was measured with the oscilloscope original 10x probe simultaneously as pin 20 (first mixer output) was measured with an 1x probe, the first mixer gives a good output. When removing the 10x probe, the mixer output dies. The 10x probe is acting like a 1 M $\Omega$  resistor in parallel with a 12 pF ca-

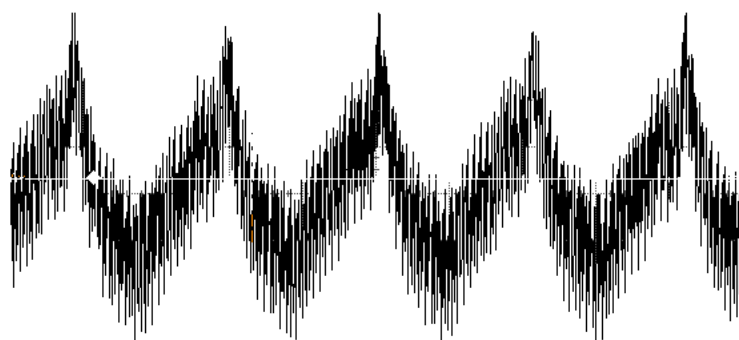

**Figure 6.16:** Noisy SA606 demodulation

capacitance, and was evidently changing the oscillator circuit so much it starts to work. Probably, the C6 trim cap (see [16] figure 4.) is too small. When soldering in an 10 pF capacitance in parallel with C6, the circuit functions, but output still was noisy.

The reason for the noisy demodulated signal is found by looking at figure 4 in [16], at the network connection pin 7 and 8. When the internal op-amp has a feedback network like in the data sheet, it will actually amplify the high unwanted frequencies by a factor of 2, and the low frequency data signal by a factor of 1. When connecting R10 and C27 in parallel to ground, the feedback network works as a low pass filter, a much more desired operation, as earlier explained.

### 6.6.1 First Test

The HP 15 MHz generator is configured to output a 15 MHz FM modulated signal with a frequency deviation of 9.6 kHz and a modulation rate of 9.6 kHz at output level -22 dBm. This is coupled through a 20 dB attenuator before connected to the RF port on the ASK-1 evaluation board. The HP 20 GHz generator is set up to output a signal of 60.01 MHz<sup>1</sup> as LO, at -7 dBm. The mixer then generates a 45 MHz component together with a 75 MHz component, shown in figure 6.19. The mixer output signal is then filtered by the PIF-40 filter (see appendix C) before it is connected to the SA606. The setup is shown in figure 6.18.

Signal levels was measured after each of the SA606s components. See extensive results in appendix A. The de-modulated output is shown in 6.20.

It is observed from figure 6.20 that output signal swings almost rail-to-rail. The output signal is stronger than earlier project work shows [12], it is believed that the changed output network is the reason for this.

<sup>1</sup>Need to be this frequency to meet the 455 kHz filter at center frequency. The frequency generator might be a bit offset

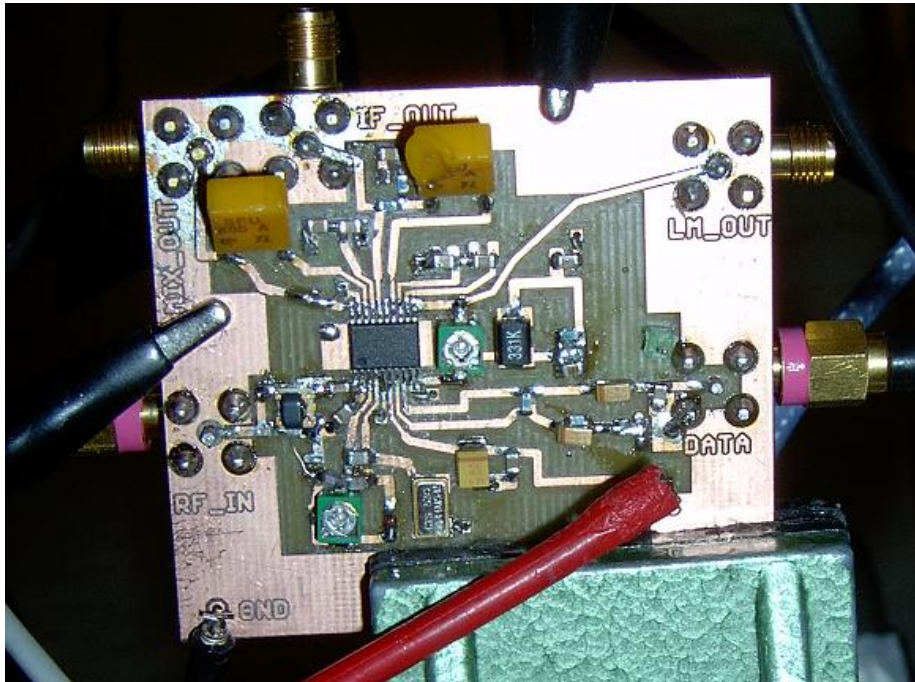

Figure 6.17: SA606 circuit board

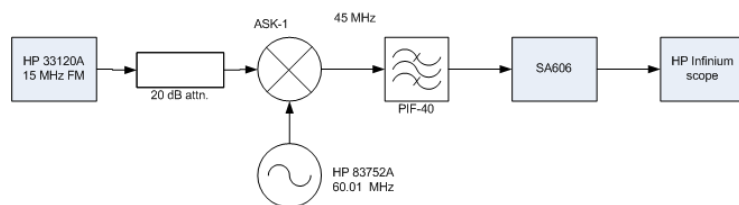

Figure 6.18: Setup of test 1



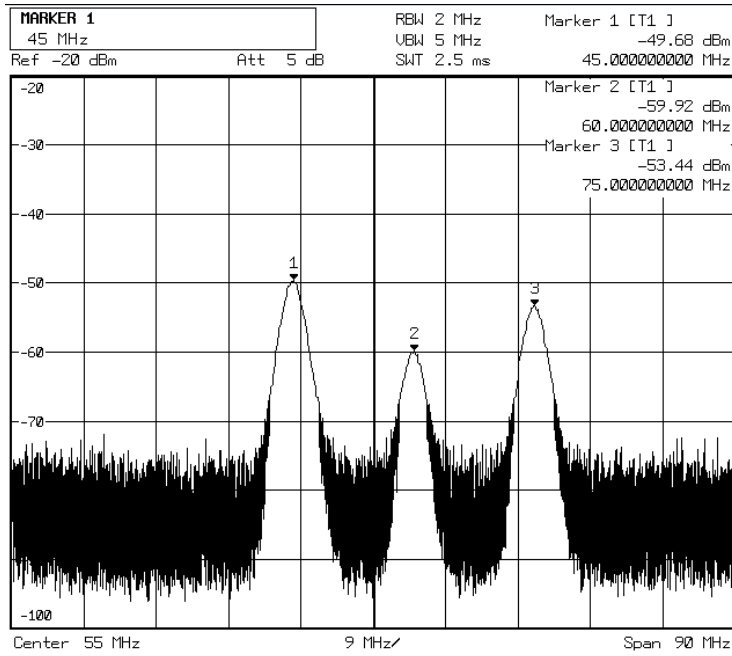

Figure 6.19: Specter after the ASK-1 mixer, first test, filtered

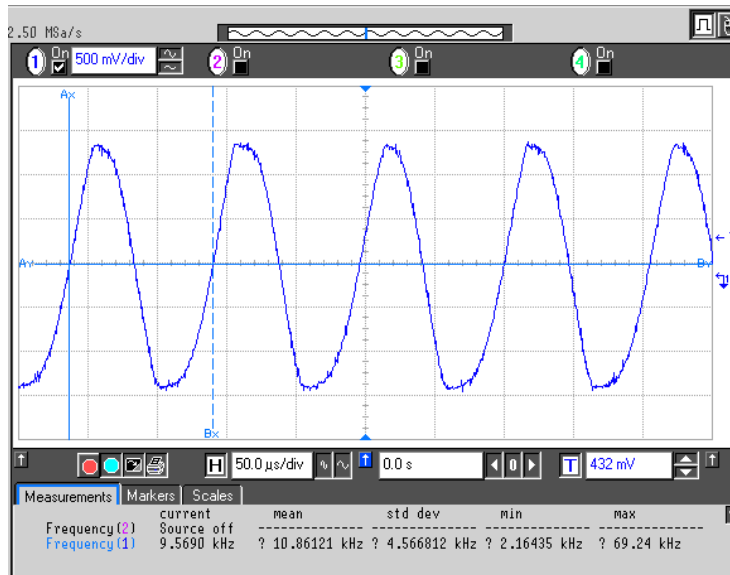

Figure 6.20: Demodulated signal, test 1. Signal pattern: 1010

### 6.6.2 Second Test

The purpose of the second test, was to use a more "realistic" setup, similar to the final application. This means applying a weak 145 MHz signal through the mixer, to convert it to 45 MHz.

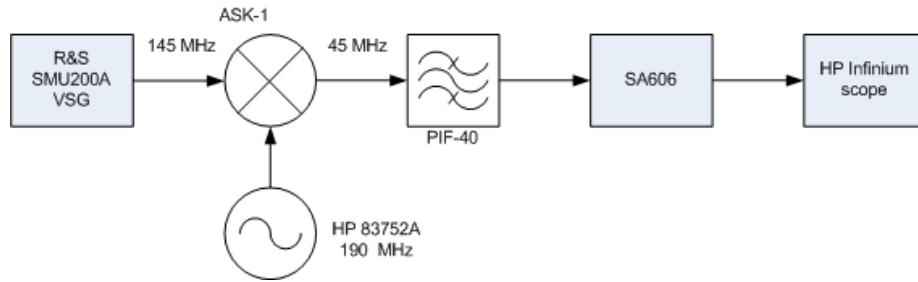

Figure 6.21: Second test, configuration

The VSG is connected to the ASK-1 mixer at RF port, the HP 20 GHz frequency generator is connected to the ASK-1 LO port, and the IF-port is connected to the SA606 through the PIF-40 filter as shown in figure 6.21. Note: tests with the mixer and the SA606 is done without any LNA. This is because neither the RF2472 nor the RF2878 has showed any good results so far.

Different input levels was applied, as well as two different bit sequences. The results shows that SA606 can demodulate a signal well as low as -85 dBm input to the ASK-1 mixer. All measurements is evaluated on the HP infinium scope, and was done without actively adding noise from the VSG. A -85 dBm signal output from the signal generator gives a signal of about -90 dBm at SA606 input, see figure A.14. As shown in figure 6.22, the SA606 can demodulate the signal. Lower signal levels was tried, at about -90 dBm RF level it is still possible to see the waveform, but it is distorted. More measurements with different input levels and different patterns can be found in appendix A.

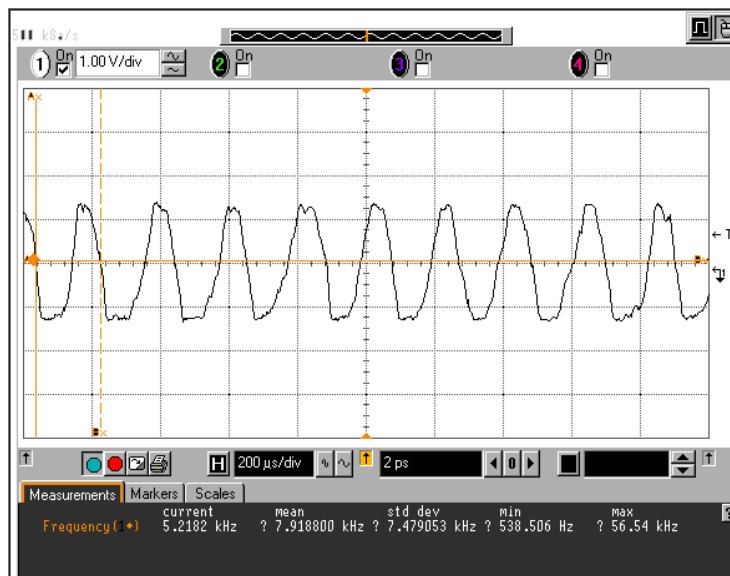

Figure 6.22: Demodulated signal, -85 dBm RF level

## 6.7 GMSK-modem - CMX909B

Embedded software for a microcontroller controlling the modem to test send and receive procedures has been written. The code can be found in appendix H.3. The modem is mounted on the interface card, and connected to the AT-Mega64 (see [22]) mounted on the Atmel AVR STK500 (see [20]) and STK501 (see [28]) boards.

The modem is natively operating on a defined frame format. This means the package structure is more or less defined if FEC and interleaving are to be used. The modem can transmit single bytes, but then FEC and interleave functions are inaccessible. This will also leave the programmer to deal with more timing issues.

### 6.7.1 Transmit Mode

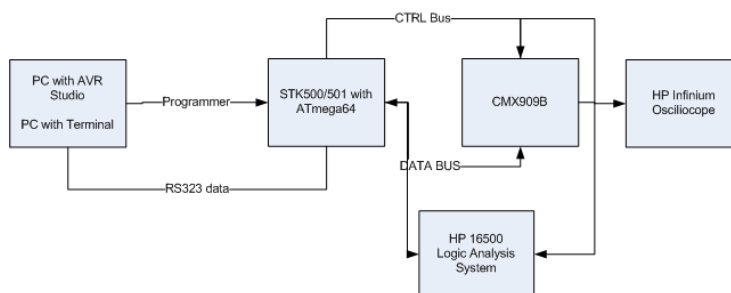

Figure 6.23: CMX909B programming setup

A test program for data transmission was written. The function generating the data to be sent (`void modem_send_data()`) in *functions.c*, see appendix H.3 is for pure demonstration use only, but the general functions for modem communication as

```
void modem_write(unsigned int address, unsigned int data);,
void modem_reset(void);,
void modem_set_datarate(void);,
void modem_set_transmit(int en_scrambling);,
void modem_init(void);,
void modem_getstatus(void);,
int modem_read(unsigned int address);,
and int modem_RX_ISR(int slow); are written to be used in further applications.
```

The modem was connected to the AVR as explained, and the output was connected to the Infinium scope. The test program implements some testing features, such as mode-selection by STK500 buttons and output serial RS232 data to the programming computer so program status can be read on screen by a terminal program. Of course, such features must be removed in the final program. Figure 6.23 shows the setup.

After solving the first timing issues by using a HP165000 Logic Analysis System, a functional transmit procedure was achieved.

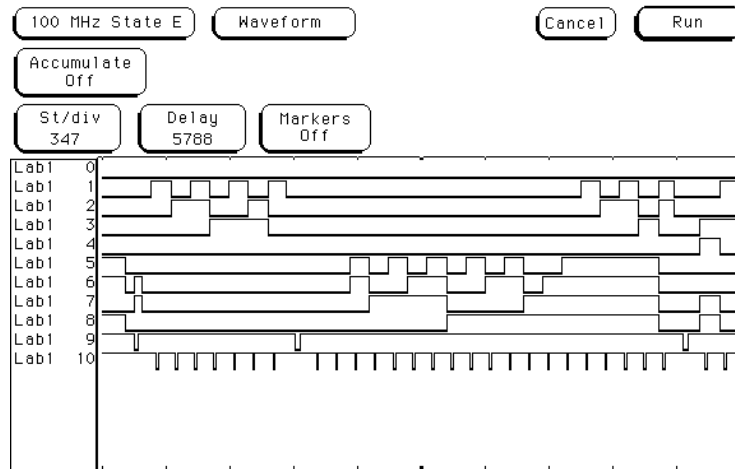

Figure 6.24: CMX909B Send Data

Figure 6.24 shows shows the most important control signals together with the data bus between the CMX909 and the AVR. *Lab1 - Lab8* is data bus *A0 - A7*, *Lab9* is RDN (Read Enable) i.e read from modem and *Lab10* is WRN (Write Enable) i.e write to modem. *Lab0* is not used.

## 6.7.2 Receive Mode

It was found difficult to test the receive function of the modem properly. A configuration where the R&S VSG was used to continuously send frame sync bytes (11001100) in GMSK format, did cause the modem to lock on the frame,

but when displaying the frame sync bytes on a computer, they varied and was never like the bytes sought for.

The signal generator can not be used to test reception of a full package, since it is not capable of creating the needed package format. Therefore, two evaluation boards were made, and connected as shown in figure 6.26.

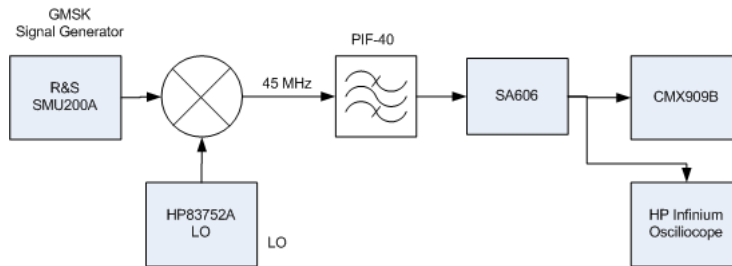

Figure 6.25: CMX909B RX test setup

Components as the mixer and the SA606 introduces several error sources. A de-modulated signal is present on the SA606 output, and measured on the CMX909B input. The modem detects the signal, as it starts to look for the frame sync bytes, but it is not able to demodulate the received signal. The reason for this is not yet found.

It was also tried to directly connect the two modems to each-other, but it seems the modem cannot drive the the RX input on a other modem. The voltage level drops with over 50% when the two modems are connected. A simple opamp buffer should be designed, to see if a stronger signal helps. In addition, the RX feedback network should be further checked, as described in [11]. If this network is not adjusted to the input signal level, the receiving modem will not be able to detect the input. Time is not allowing further tests to be carried out.

## 6.8 Power Estimate

Since no components are yet found for the transmitter, no other estimate for consumed power can be found other than the estimates with basis on figure 4.6.

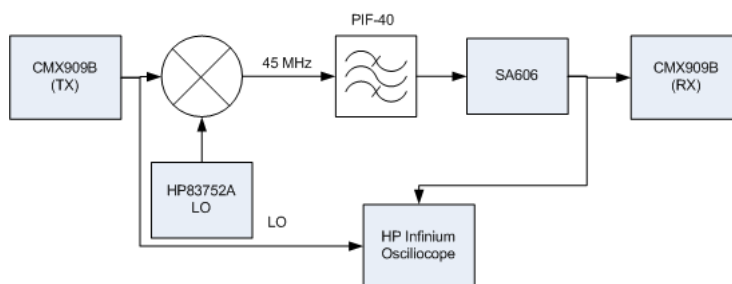

Figure 6.26: CMX909B to CMX909B test setup

For the receiver, the MCU will consume about 2 mA itself plus any current to drive I/O-pins. Since all signals are digital and high impedance, this contribution will be small. The SA606 needs about 3.5 mA and the modem will use about 2 mA at 3 V. This totals to less than 10 mA, i.e about 30 mW. Other components such as LO and LNA will also consume power, but it seems there should be no problem keeping consumed power below the assigned 200 mW.

# Chapter 7

## Discussion

### 7.1 Overall Design

All three radio system designs require some sort of programming. Software are inherently prone to memory errors due to bit-flips (if not Rad-Hard memory is used) provoked by high-energy radiation, or other hardware malfunction. If this is thoroughly considered, solutions for re-programming the radio can be implemented. This might not necessary for this particular project, taking the estimated in-orbit lifetime of only a few months into account. It seems too categorical to reject the integrated transceiver based on the radiation damage argument, since all three designs have much the same need for a MCU with software.

When regarding the choice of modulation method, clearly, the choice was decided due to the CMX909. This was the only modem found capable of high bit-rates. If a lower bit-rate is acceptable, FSK-modems are available, capable of a bit-rate of 1200 bps. Such a modem could be used, leaving the rest of the analogue design unchanged.

The second method, featuring a VCO modulator and a PLL de-modulator is simple in method, but would probably take more time to build than the chosen alternative. In addition, its software demand is much bigger, so the decision to not go further with that one is considered correct.

### 7.2 Digital Part

When first sought for, in early design phase, the CMX909B seemed a good choice. The modem implements FEC, interleaving and scrambling on transmitted and received data. All those functions are good tools to ensure successful data transfer. Later, during the testing phase, it was realized that CMX909B only can be used effectively with the Mobitex frame format using these utilities. The scrambler is anyway optional. This implies some constrains on how to implement the communication protocol. To make the most of the modem, data must be transmitted using Mobitex frames, though it is possible to receive and transmit single bytes of data without FEC and interleaving, enabling a completely user-defined package format.

If it is desired to create a user-defined package structure, or transmit data using another frame format, the CMX589 modem could be the better choice. This modem does not implement FEC, interleaving nor scrambling, it simply converts a digital bit-stream to a GMSK baseband signal for TX, and recovers a bit-stream from a baseband signal while RX [29].

Which one of these two solutions is the best, depends upon a number of aspects. If it is acceptable to use the Mobitex protocol, the modem will use its native operations and the user does not have to think about calculating FEC, correcting errors with FEC nor any de-interleaving. If the freedom of defining own package structures is the most important, the CMX909B is not the correct choice, as it will require more microcontroller software, and probably invoke timing issues between the modem and the microcontroller if single-byte transfer and receive modus is used. The CMX589 will provide the needed functionality in a simple circuit.

It is worth mentioning, both modems takes care of the important, and difficult, tasks of bit timing and bit recovery.

### 7.3 Analogue Side

The SA606 seems to be a versatile circuit for baseband recovery. The circuit has low power demands and a huge dynamic range. It provides a rail-to-rail output<sup>1</sup>. If the minimum power level is compared to the link budget, it is seen that the lowest power level successfully demodulated is near the up-link power level at case power. There should be no problem using the SA606 together with a single stage LNA with gain between 20 and 30 dB. Problem areas are mainly the oscillator stability and the mounting of the current crystal package.

### 7.4 Amplifiers

No real good results have been found regarding the amplifiers. None of the proposed LNAs should be used if 50  $\Omega$  match on the output is needed, even though both provide a sufficient amount of gain, in the order of 20 dB (RF2472) to 30 dB (RF2878).

No work has been done considering PA amplifiers and buffers. The reasons for this are a combination of poor simulation results for the RF2878, which was proposed as buffer, and the efficiency of RF5110G (stated to be 44% in [15]). More time must be used to come up with alternative solutions. A good proposal is to suggest student 9<sup>th</sup> semester assignments, such assignments will be given the autumn 2007.

### 7.5 Filters

As briefly discussed before, low pass filters at RX and TX must be considered. At RX the filter is needed due to the resonant peak at UHF frequencies for the

---

<sup>1</sup>The tests described over was performed with VCC = 6 V, but the same has applies for VCC = 3 V.



proposed antenna. If the LFCN-120 or LFCN-160 filter should be used, depends on system noise properties, favoring LFCN-160, and a lower corner frequency, favoring LFCN-120. This decision can be postponed until more overall parameters for the receiver is known. When regarding TX, a filter is not needed if the buffer amplifier and PA is linear enough to not generate too much out-of band components. When the output spectrum from those amplifiers are known, this can be decided.

## Chapter 8

# Conclusion

During the work process, especially the lab work, it became clear that the scope of this project had to be narrowed. This also because of lab measurements not being as good as expected. Most of the focus during the lab-phase lay on the analogue receiver part, in addition to the digital modem.

Even though it was decided not to build a final prototype, the project leave behind much work which can be built upon on a later stage. The SA606 is verified, and the application schematic is improved compared to earlier projects. Unfortunately the receiver part of the CMX909 is not verified, but the modem is versatile and quite easy to work with. No good LNA solution is found, the RF2472 and maybe also the RF2878 seems to be a dead end in this frequency band.

If focusing upon the importance of having a functional radio prototype, the current design proposal was not the correct one. It is too extensive to be carried out in a 20 week work period. All work regarding design, assembly and test of both analogue and digital electronics is very time consuming. Choosing the integrated transceiver design probably would have lead to a more finished product. This could also have given time to further investigate the critical antenna connection/matching. A more thorough study of the digital side and the overall TT&C-system could maybe also been achieved. Then, the issues regarding the LO might be avoided as the transceiver features its own internal oscillator, only a good external crystal is needed. Anyway, work regarding the PA and LNA must have had been done, but a low-range prototype could have been created without those.

GMSK was chosen as modulation method due to the modem. This might not be the most adequate modulation due to the inherent inter-symbol interference, even though GMSK provides good spectral efficiency. It depends upon the project goal. If the goal is to get (some) information safely transmitted to the ground station, a simpler low-rate FSK radio could be used. Regular FSK can be generated using several methods, a VCO, a FSK (low rate) modem and it is supported by integrated circuits like the ADF7020-1. Such an integrated circuit could also be used as de-modulation and would support a wide range of bit rates.

The main results in this work are the findings regarding to the RF2472 and the changes in the SA606 design. These findings will save prospective students much labor, hence the documentation in the developed project database will be

important.

It is also worth mentioning that the design outlined in this report is fairly close to the ncube designs. This shows that this design probably is the way to go if a fully-integrated system not is desired, based upon available components in the market, like the SA606 and the GMSK-modem.

### 8.1 Further Work

In order to build a working engineering model of this design, the LO-issue must be solved, as well as the modem receive issue, together with finding LNA and PA. Clearly, this will be extensive work, and the design must maybe be re-considered if NTNU determines to go on with the satellite project on a later stage. If the wish is to build a satellite from scratch, the designs should really be kept *simple*. Focus should lay upon producing a working satellite, where its possible to replace sub-systems after re-designs over time

Overall, the conclusion is that for radio project as this one, an approach like presented in this project is too time consuming. A maybe more suitable partition of tasks can be:

- Antenna System
- Define and implement the needed TT&C-protocol on a MCU
- Find and test an off-the-shelf fully integrated transceiver
- Find or design LNA-, buffer- and PA stages

Hopefully, other students will follow-up the work done this semester.

**Part II**

**Student Satellite Project**

## Chapter 9

# Background

During the spring of 2006, Professor Odd Gutteberg launched a proposal for a 9<sup>th</sup> semester assignment regarding a pre-study of a new student satellite project at NTNU. Three students were assigned this task, together with a doctorate student. The project started with the goal to investigate the possibility of a student satellite project at NTNU, but quite soon evolved into a large project with much wider scope, including a specification document for a satellite concept.

At the same time, Norwegian Centre for Space-related Education (NAROM) indicated they would launch a proposal contest for Norwegian universities and university colleges to design and build a total of four new student satellites. NAROM launched their contest during October 2006, and the student group handed in their application in December. This proposal received the highest technical and overall evaluation from the expert group assigned to select the contest winner. Despite this, the NTNU project was not awarded the launch.

During spring 2007, two students from Engineering Cybernetics (ITK) and one exchange student from Spain also got involved in the project. The ITK students wrote master theses concerning the Attitude Determination and Control System, while the exchange student has worked with the antenna systems and commenced on a study of a ground station.

## Chapter 10

# Project Work

Two students, Erik Narverud and the author, have done most of the project management related work during the spring of 2007. A project manager, doctorate student Lars Løge, was appointed during 2006. He had a semester abroad in the spring of 2007, and could not undertake the project administration. The administration work included weekly technical interchange meetings and developing and carrying out presentations for future students. A database and Internet site for the project were planned developed. Halfway in the semester, a system review meeting with participants from leading space industry in Norway were and planned and arranged. The work has been extensive, but very interesting and inspiring for further studying and work. The project management work has also given the students system design and project work experience, in a degree not usually gained during a masters thesis.

Figure 10.1 shows a brief work log for Roger Birkeland. About 4 to 5 weeks have been used for project management.

### 10.1 Project Assignments and Master Theses

Suggestions for student assignments and master theses have been worked out, based on important design factors in the overall satellite design. They can be found in appendix J. The assignments are multi-discipline, crossing the fields of radio, cybernetics, embedded systems and mechanical construction. At the time of writing, it is not know if any assignments have been chosen.

### 10.2 Student Presentations

Student presentations were made in an attempt to secure a continuity in the project and to present further necessary work. The presentations were held by Erik Narverud and the author for third and fourth grade students at the Institute For Electronics and Telecommunications at NTNU. The presentation can be viewed in appendix J.

### 10.3. SYSTEM DESIGN REVIEW ARRANGEMENT

#### Work Log

Week	Date	Main Focus During Week
0	28. January	Review and "clean-up" from project. Project database and web page
0	3	Project database and web page
1	4-22. January	Official Start Date. Study of similar student projects
2	5	
3	6-5. February	
4	7	System design. Link budget. Components
5	8	Find components. Check specifications
6	9	Design check, system design review preparations
7	10-5. March	System Design Review preparations
8	11	System Design Review 13. March, meeting and after work
9	12	Student Presentations – Prototype Design
10	13	Prototype Design – RF2472, SA606, Switch, Mixer, Filters
	14-2. April	Easter
	15	Easter
11	16	Prototyping and measurements – RF2472
12	17	Simulation – RF2878, measurements SA606 and mixer
13	18	
14	19-7. May	Measurements + report Measurements + report
15	20	Measurements + report, start with CMX909 code
16	21	CMX909 – write code + lab
17	22	CMX090 – lab + report
18	23-4. June	Report
	24	Course at Andøya – Space Technology II
19	25	Report
20	26	Finalize report

Work concerning overall project management  
No work done

Figure 10.1: Work Log - Roger Birkeland

## 10.3 System Design Review Arrangement

Half way through the semester, a full-day System Design Review (SDR) was planned and carried out. Representatives from other groups at NTNU, The University of Oslo, Norspace, Sintef and Conax were attending. The meeting gave the students a contemporary evaluation of the satellite concept. Many of the attendants had substantial knowledge of space engineering, this gave the review vital information and advice to the students. The report from the meeting can be found in appendix I.

## 10.4 Technical Interchange Meetings

In the planning phase of the project work, before prototyping work commenced, weekly meetings between all students involved in the project were held. These meetings made it possible to exchange important information on an early design stage. Important decisions, as data bus protocol and power distribution solutions were discussed, giving a more solid foundation for further work.

## 10.5 Other Institutions

During the SDR, the representative from UiO presented a possible payload for a small satellite. A Langmuir probe is a device to measure and survey structures of free electrons in the ionosphere. These structures have as know

## CHAPTER 10. PROJECT WORK

---

an effect on radio signal propagation. Contact with UiO should be maintained if the satellite project at NTNU resumes.



## Chapter 11

# Project Database Development

Bitter lessons from earlier satellite project has unveiled the biggest drawback of student satellite projects, as the lack of information control. The "project staff" is continuously being replaced, and it is very difficult to keep a sustained level of knowledge within the project. To counteract this problem, the project group saw the need for a database that could store theses, reports, schematics and data sheets and make them available for future students. The hierarchical concept was based upon a classification of the satellite systems, with subsystems, units and components as the principal entities. The database was given a web interface with user limited access. A public web portal was also developed, integrated with the same backend database. The database development was primarily done by the author, with some inspirational aid from the Erik Narverud.

## Chapter 12

# Project Database Documentation

The project database is divided into two web applications, one internal for project members only, and one public accessible web page. Both web applications is written in PHP4 with a common backend mySQL database.

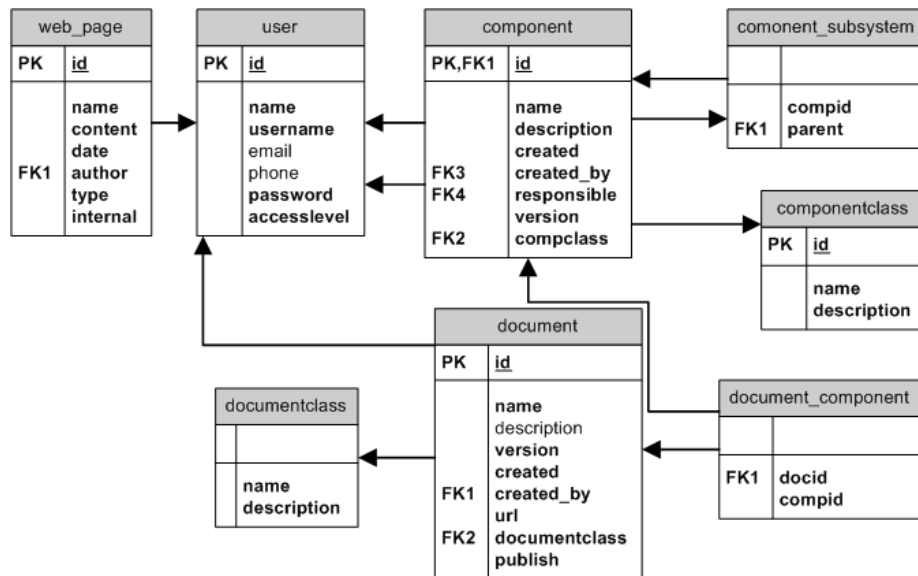

Figure 12.1: Database diagram for project database and web page

Figure 12.1 shows the database diagram. The database holds all information about subsystems, components, units and document. The database does not hold the document itself; only a link to it.

## 12.1 Project Database

All active project members can edit the project database when logged in. The user can navigate "through the satellite" via an expandable hierarchical menu, shown in figure 12.2. All bold-face menu elements marks parents for the SA606, used as an example. It is seen that the SA606 (component) is a part of the "Receiver" (unit) in the "145 MHz radio system" (unit) in the "TT&C"-system (sub-system) in the satellite system (with an un-official working name 'Nexus').

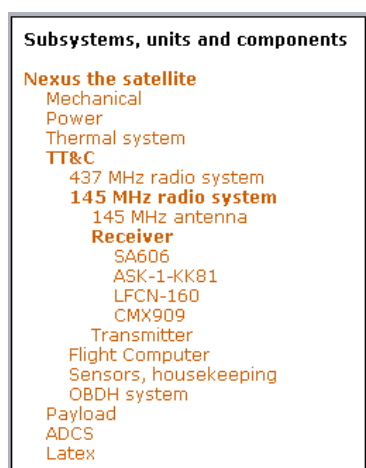

Figure 12.2: Project database - menu

The hierarchical elements are divided into several classes; sub-system on the top, which contains units which contains components.

Figure 12.3 shows a section of the web page containing information about the SA606 component. Several documents are found, like the data sheet, Eagle project files and pictures of schematics and board outline.

This way, the document database provides an easy way of sharing and publishing documents while clearly showing where the document belongs in the satellite project. A "View all documents"-function is also available, sorting documents in their document class. Navigation through the project is easy, but a search function can easily be implemented.

The PHP-code for the web page will not be further commented in this report, but can be found as an electronic attachment.

## 12.2 Web Page

The web page is found at <http://org.ntnu.no/studsat>. The public part contains general project information about the project, past, current and future assignments, documents for downloading<sup>1</sup>.

An internal part of the web page is visible to project members. Internal pages, like user contact lists, can be added through the administration system

<sup>1</sup>Documents can be published to web page by selecting "publish" in document properties in the project database/administration system

**Nexus project database - Roger Birkeland**

[\[Home\]](#) [\[Back\]](#) [\[View all documents\]](#) [\[View users\]](#)





Showing data for the Component SA606

[\[Edit\]](#)

<b>Name:</b>	SA606	<b>Created</b>	2007-06-07
<b>Created by:</b>	Roger Birkeland	<b>Version</b>	0
<b>Responsible:</b>	Roger Birkeland		
<b>Description:</b>			
IF Subsystem with mixers and amplifiers. Operate on RF = 45 MHz and IF = 455 kHz. This is the baseband re-generator.			

[\[New\]](#) [\[Add\]](#)  
Found no units or components.

[\[Add\]](#)

Document	Type	Description	Version	Edit
 <a href="#">SA606.pdf</a>	Datasheet	This is the datasheet for the SA606	0	<a href="#">[E]</a> <a href="#">[X]</a>
 <a href="#">SA606_board_rev1.png</a>	Picture	Board outline, rev1	0	<a href="#">[E]</a> <a href="#">[X]</a>
 <a href="#">SA606_schematic_rev1.png</a>	Picture	Schematic, rev1	0	<a href="#">[E]</a> <a href="#">[X]</a>
 <a href="#">SA606_schematic_rev2.png</a>	Picture	Shematic, rev2	0	<a href="#">[E]</a> <a href="#">[X]</a>
<a href="#">SA606_eval.brd</a>	Schematic	Eagle board outline	0	<a href="#">[E]</a> <a href="#">[X]</a>
<a href="#">SA606_eval.sch</a>	Schematic	Eagle shematic	0	<a href="#">[E]</a> <a href="#">[X]</a>
<a href="#">eagle.epf</a>	Schematic	Eagle project file	0	<a href="#">[E]</a> <a href="#">[X]</a>

[\[Logout\]](#)

Figure 12.3: Project database - SA606

and hidden from general users.

### 12.2.1 Administration

The web page shares the administration system with the project database. Web page contents can be added, edited and removed from here. Two types of content can be used; regular information (text) can be written into the administration system and saved to the database, or a link to external page, e.g. a php-script can be entered. The administration system also holds information about how to edit the menu, which is contained in a separate file.

## Chapter 13

# Conclusion

The conclusion of the project work cannot be anything but binary. On one hand, it has been both educational and inspiring to administer such a multi-disciplined and advanced development project. On the other hand, it is not recommendable to give this responsibility to students while they are doing project assignments or master theses. The extent of the work is substantial and time consuming. An administrative person should therefore be responsible for project management and supervision at all times.

Although many lecturers have been positively committed to the project, it proved somewhat difficult to gain *active* commitment from all. Participation from the lecturers is crucial, they are the ones assigning tasks to future students. As long as there is no special official commitment from the university administration to undertake such a project, it will be very difficult to complete. This is partially due to the fact that students from several disciplines must be made aware of the project. Persons with available knowledge of their particular discipline must inform and include the students in the project. Although a support group of lecturers was established by the student students, this group is not responsible for taking any initiative concerning further development.

The NAROM launch contest must be deemed as a slight failure. Not only did it fail to award the launch to the project given the best evaluation, it also failed to attract attention from institution not already with running satellite programs. To schedule the first contested launch as early as 2008, resulting in a mere year of system development, can at best be interpreted as highly optimistic. The students opinion is that NAROM should support collaboration between institutes from a *highly* defined specification, and assign a full-time *technical* administrator. The space community at Norwegian universities and colleges are not of a size capable of running several parallel projects at the same time. But, again, when involving several student groups, project management is a key to success.

For NTNUs and its students sake, engaging cooperation with foreign universities, enabling students to go abroad one or two semesters working on space- and satellite technology can be beneficial. Another possibility is engagement in ESA student projects, like SSETI. Presumably, such projects will be easier to carry through than a self-driven project with limited recourses. Student will be a part of a international program of high technical and professional level.

# References

- [1] Erik Narverud Roger Birkeland, Elisabeth Karin Blom. Design of a small student satellite, 2006.
- [2] David M. Pozar. *Microwave and RF Wireless Systems*. John Wiley & Sons, 2001. ISBN 0-471-32282-2.
- [3] NOAA. Space environment topics: The ionosphere, 1999. URL <http://www.sec.noaa.gov/info/Iono.pdf>.
- [4] H. E. Whitney J. Aarons and R. S. Allen. Global morphology on ionospheric scintillations. *Proceedings of the IEEE*, 59:159–172, 1971.
- [5] Basu S et. al. 250 mhz/ghz scintillation parameters in the equatorial, polar and auroral environments. *IEEE Journal*, 2:102–115, 1987.
- [6] Peter Berlin. *Satellite Platform Design*. Dept. of Space Science, Universities of Luleå and Umeå, Kiruna, Sweden, fourth edition, 2005. ISBN 91-631-4917-6.
- [7] Simon Haykin. *Communications Systems*. John Wiley & Sons, fourth edition, 2001. ISBN 0-471-17869-1.
- [8] D. G. Messerschmitt J. R. Barry, E. A. Lee. *Digital Communication*. Kluwer Academic Publishers, 2004. ISBN 0-7923-7548-3. URL <http://users.ece.gatech.edu/~barry/digital/>.
- [9] NCUBE. Ncube: Norwegian student satellite, 2001-2006. URL <http://ncube.no>.
- [10] Analog Devices. *High Performance, ISM Band, FSK/ASK Transceiver IC*, 2006. URL <http://www.analog.com/en/prod/0%2C2877%2CADF7020%25252D1%2C00.html>.
- [11] Consumer Microcircuits Limited. *CMX909B GMSK Packed Data Modem*, 2000. URL <http://www.cmlmicro.com/products/datasheets/Docs/cm909bd.pdf>.
- [12] Stein Joakim Log. Konstruksjon av vhf-mottaker for studentsatellitten ncube. Master's thesis, NTNU, 2004.
- [13] Mini-Circuits. *Low Pass Filter - LFCN-160+*, 2006. URL <http://www.minicircuits.com/pdfs/LFCN-160+.pdf>.

- 
- [14] Mini-Circuits. *Frequency Mixer - ASK-1-KK81*, 2006. URL <http://www.minicircuits.com/pdfs/ASK-1-KK81.pdf>.
- [15] RFMD. *3V GMS Power Amplifier*, 2006. URL <http://www.rfmd.com/pdfs/5110G.pdf>.
- [16] Phillips Semiconductor. *SA606 - Low-voltage high performance mixer FM IF system*, 1997.
- [17] Mini-Circuits. *Bandpass Filter - PIF-40*, 2006. URL <http://www.minicircuits.com/pdfs/PIF-40.pdf>.
- [18] RFMD. *2.4GHz LOW NOISE AMPLIFIER WITH ENABLE*, 2006. URL <http://www.rfmd.com/pdfs/2472.pdf>.
- [19] RFMD. *3V LOW NOISE AMPLIFIER/ 3V PA DRIVER AMPLIFIER*, 2006. URL <http://www.rfmd.com/pdfs/2878.pdf>.
- [20] STK500. *Atstk500*, 2007. URL [http://atmel.com/dyn/products/tools\\_card.asp?family\\_id=607&family\\_name%=AVR+8%2DBit+RISC+&tool\\_id=2735](http://atmel.com/dyn/products/tools_card.asp?family_id=607&family_name%=AVR+8%2DBit+RISC+&tool_id=2735).
- [21] winavr. *Winavr*, 2007. URL <http://winavr.sourceforge.net/>.
- [22] Atmel. *ATmega64*, 2006. URL [http://atmel.com/dyn/resources/prod\\_documents/doc2490.pdf](http://atmel.com/dyn/resources/prod_documents/doc2490.pdf).
- [23] Diana M. Johnson and Tien M. Nguyen. Bandwidth-efficient modulation through gaussian minimum shift keying. *Crosslink - The Aerospace Corporation Magazine*, 3, 2002. URL <http://www.aero.org/publications/crosslink/winter2002/03.html>.
- [24] Murata. *Murata*, 2007. URL <http://www.elfa.se/elfa-bin/setpage.pl?http://www.elfa.se/elfa-bin/dyndok.pl?dok=2013489.htm>.
- [25] Mini-Circuits. *SPDT RF Switch*, 2006. URL <http://www.minicircuits.com/pdfs/HSWA2-30DR+.pdf>.
- [26] Active Directivity. *Microwaves101.com*, 2004. URL <http://www.microwaves101.com/encyclopedia/ampdirectivity.cfm>.
- [27] Mini-Circuits. *Low Pass Filter - LFCN-120+*, 2006. URL <http://www.minicircuits.com/pdfs/LFCN-120.pdf>.
- [28] STK501. *Atstk501*, 2007. URL [http://atmel.com/dyn/products/tools\\_card.asp?family\\_id=607&family\\_name%=AVR+8%2DBit+RISC+&tool\\_id=2926](http://atmel.com/dyn/products/tools_card.asp?family_id=607&family_name%=AVR+8%2DBit+RISC+&tool_id=2926).
- [29] Consumer Microcircuits Limited. *CMX909A GMSK Modem*, 2000. URL <http://www.cmlmicro.com/products/datasheets/Docs/cmx589ad.pdf>.

**Part III**  
**Appendices**



# Appendix A

## SA606 - Documentation

### A.1 Schematic

The first layout was more or less equal to the reference design in [16], except for SMA-connectors at 1. mixer out, IF-amp out and limiter out. The filters FILT1 and FILT2 is not of the preferred type, but of similar characteristics. Input impedance is 3000  $\Omega$ . IFT1 is replaced by a single inductor.

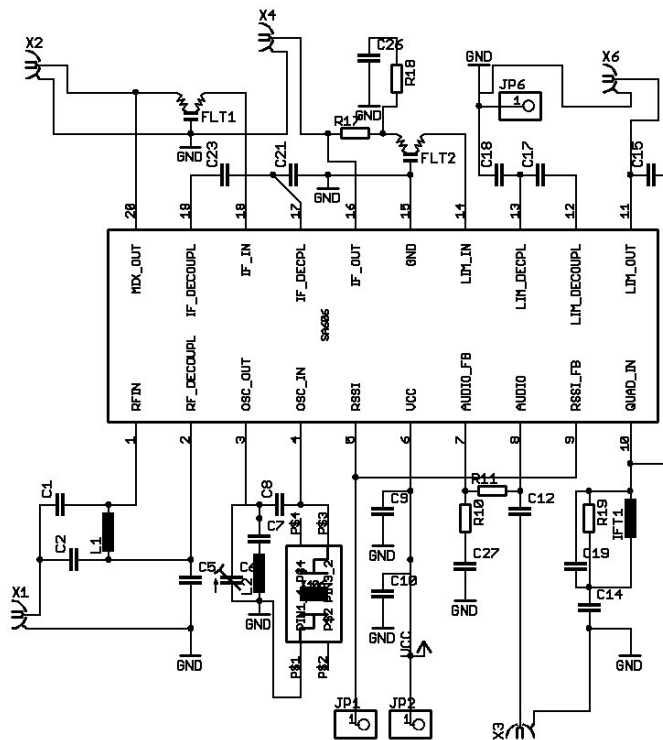

Figure A.1: SA606 Schematic, version 1

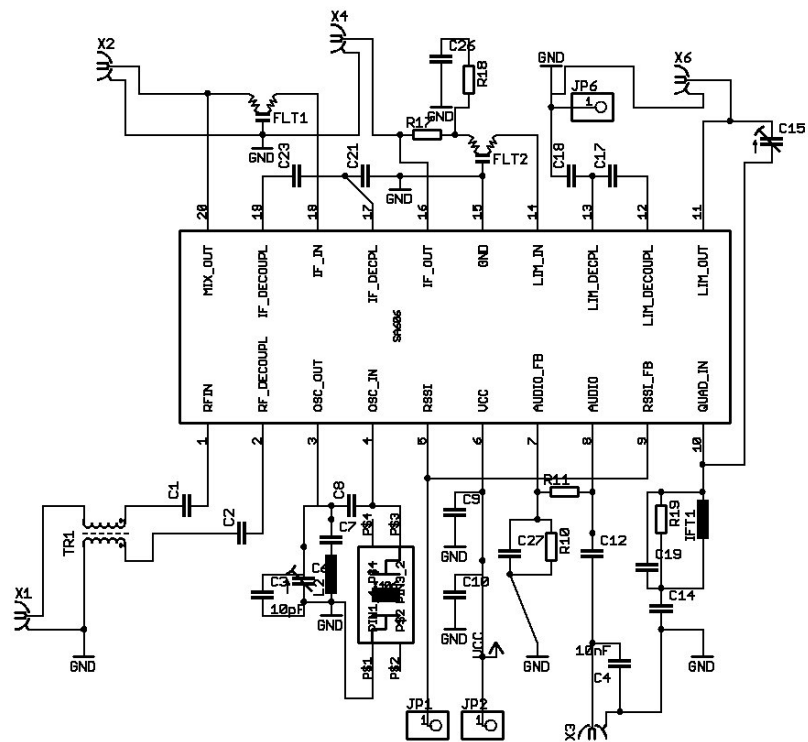

Figure A.2: SA606 Schematic, version 2

## A.2 Board Layout

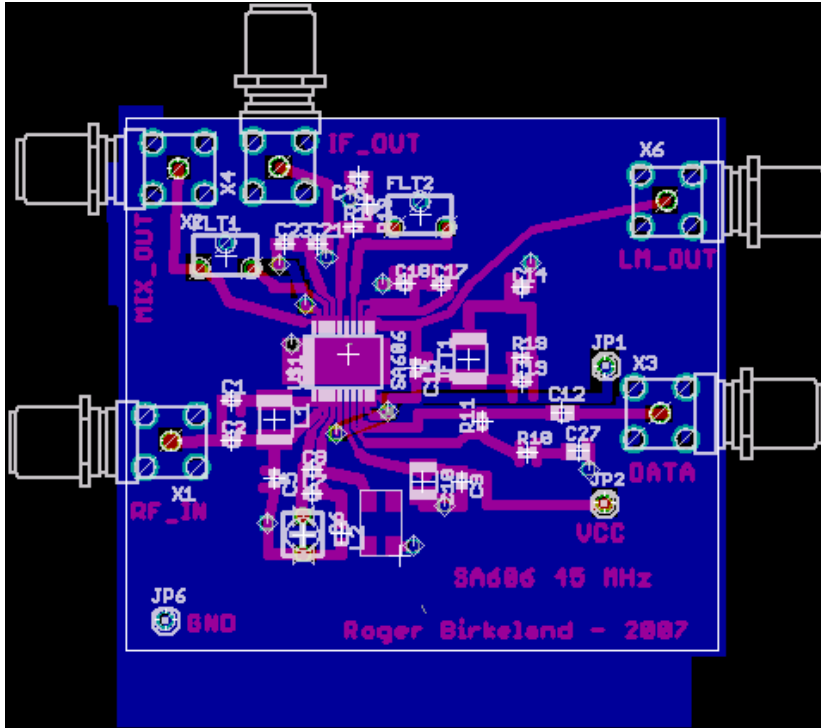

Figure A.3: SA606 Board, version 1

Figure A.3 shows the board layout for the first revision. A new board implementing the changes in schematic 2 was not milled. The original board was just modified to implement the changes. A new board outline is found in A.4.

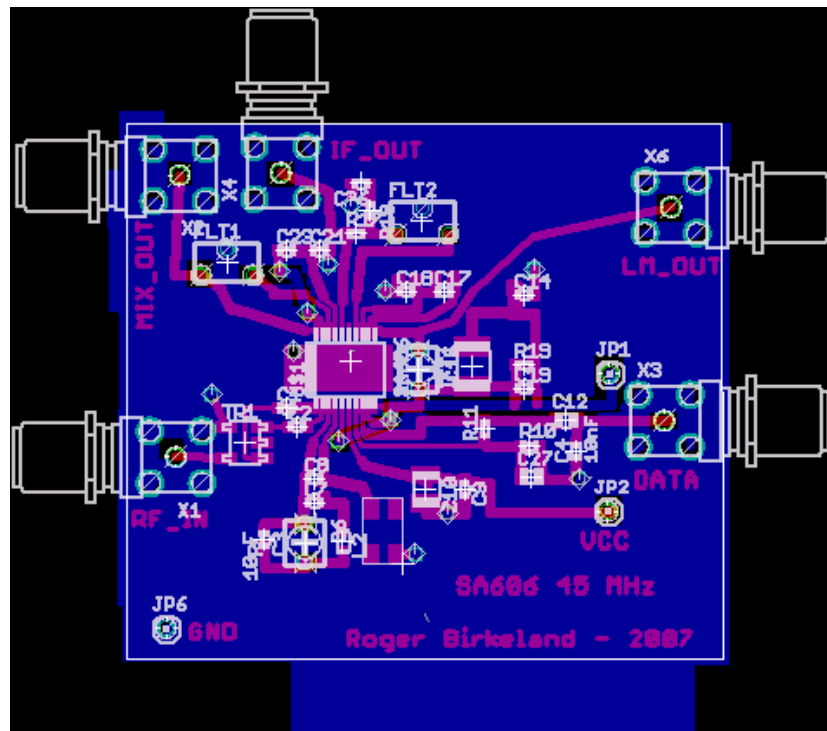

Figure A.4: SA606 Board, version 2

### A.3 Component Values

Component	Value	Component	Value
C1	220 pF	C23	100 nF +10%
C2	220 pF	C26	100 nF +10%
C4	10 nF		
C5	100 nF $\pm$ 10%	C27	2.2 $\mu$ F Tantalum
C6	5-30 pF trim cap	Flt1	455 kHz Filter
C7	1 nF	Flt2	455 kHz Filter
C8	10.0 pF	IFT1	330 $\mu$ H
C9	100 nF	L1	0.33 $\mu$ H
C10	10 $\mu$ F $\pm$ 10% Tantalum	L2	1.2 $\mu$ H
C12	2.2 $\mu$ F $\pm$ 10% Tantalum	X1	44.545 MHz Crystal
C14	100 nF $\pm$ 10%	R10	8.2k +5%
C15	5-30 pF trim cap	R11	10k +5%
C17	100 nF $\pm$ 10%	R17	2.4k +5%
C18	100 nF $\pm$ 10%	R18	3.3k +5%
C19	390 pF $\pm$ 10%	R19	11k +5%
C21	100 nF $\pm$ 10%		

Table A.1: SA606 Component Values

### A.4 Test Results - Test 1



Figure A.5: Test setup (SA606, mixer and filters)

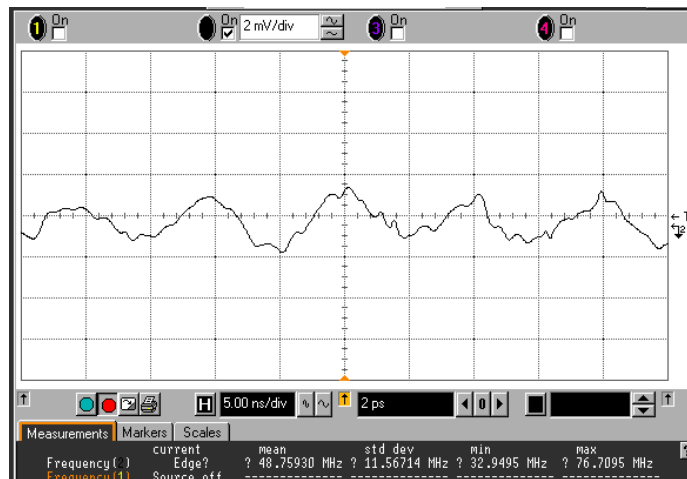

Figure A.6: IF signal in at 1. mixer. The signal level is weak, so there are a considerable amount of noise present.

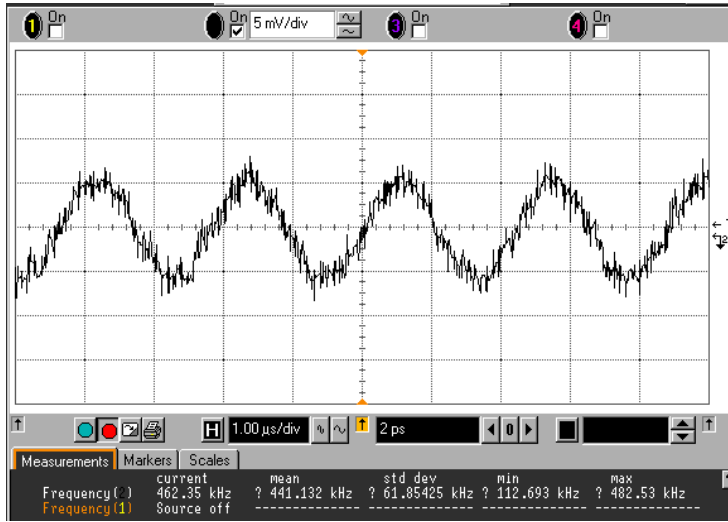

Figure A.7: Unfiltered signal from 1. mixer

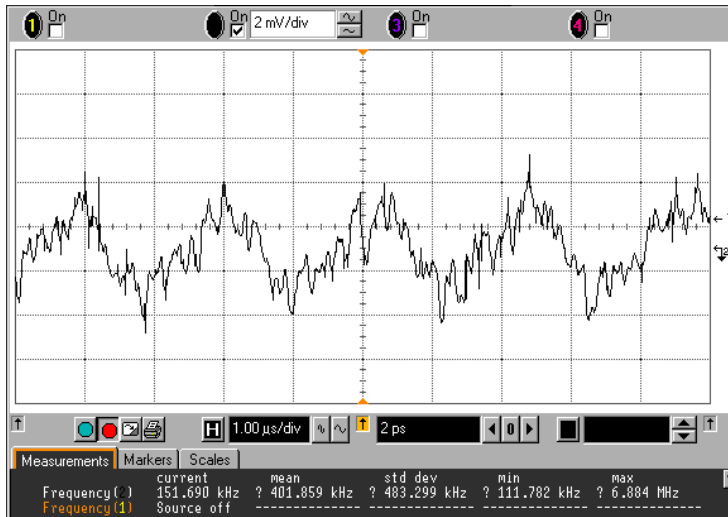

Figure A.8: Filtered signal from 1. mixer. This signal is input at IF amplifier.

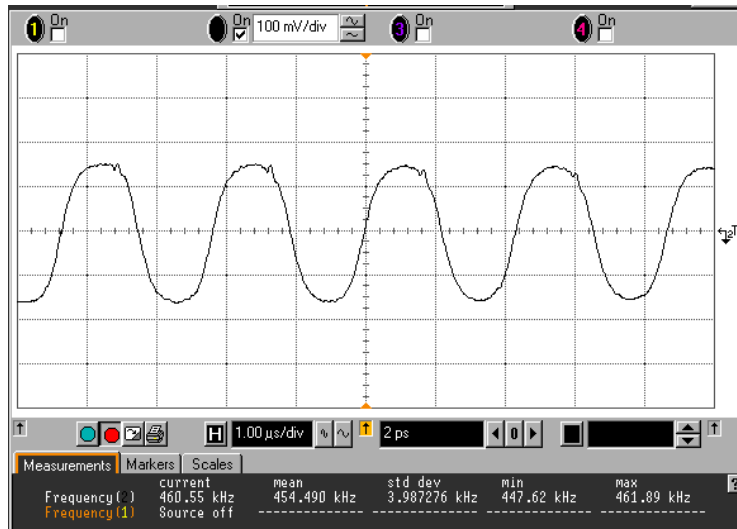

Figure A.9: Unfiltered signal from IF amplifier

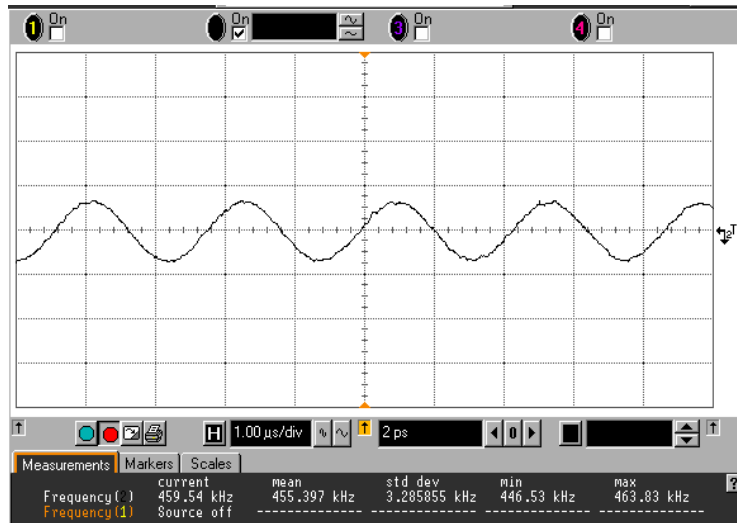

Figure A.10: Filtered signal from IF amplifier



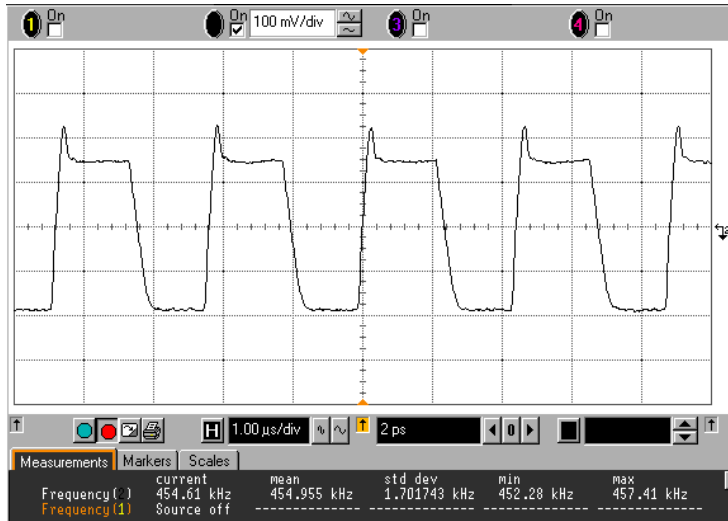

Figure A.11: Limiter output

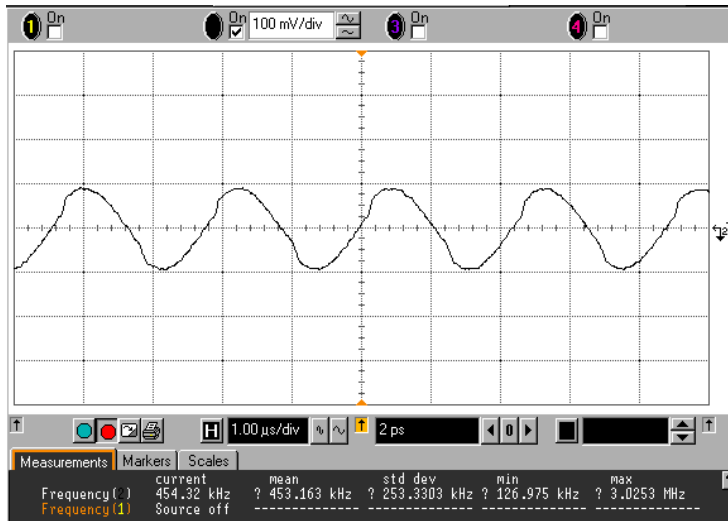

Figure A.12: Signal input to quad-demodulator

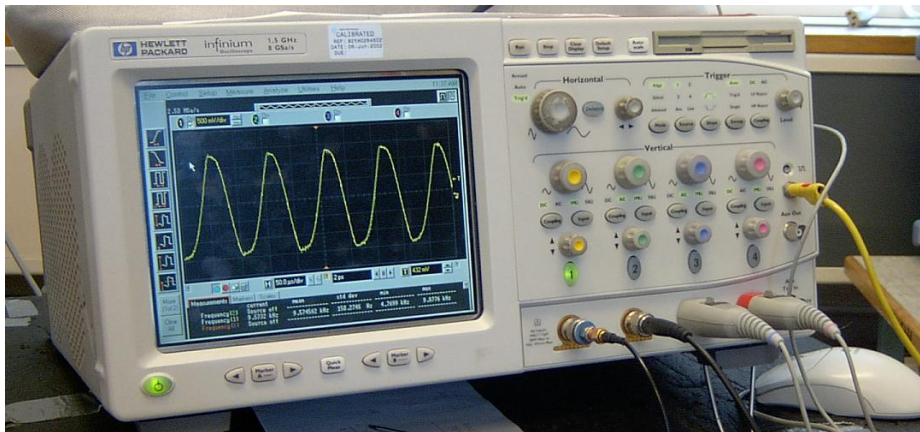

Figure A.13: Demodulated 9.6 kHz signal!

## A.5 Test Results - Test 2

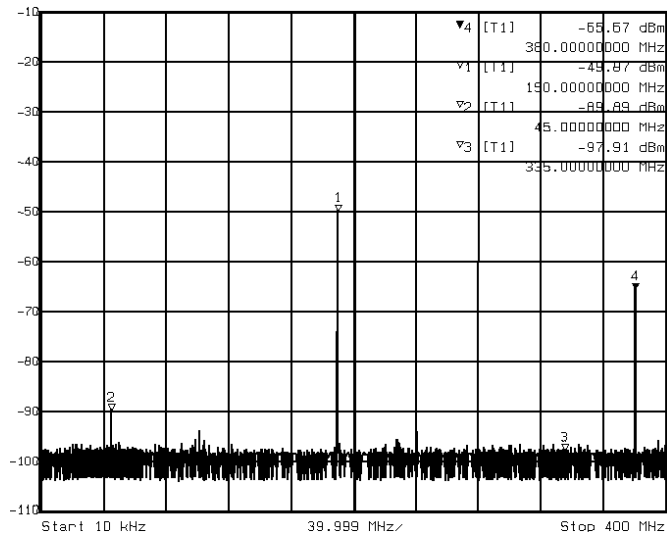

Figure A.14: -85 dBm signal from generator, -90 dBm signal input to SA606.

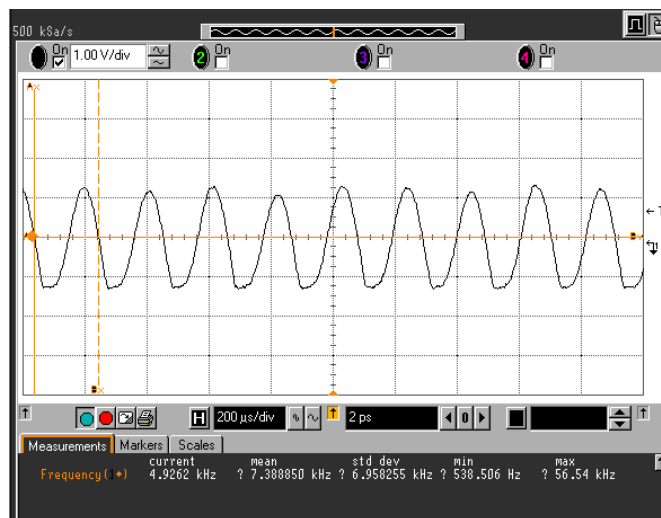

Figure A.15: Demodulated signal, -40 dBm RF. Pattern: 1010

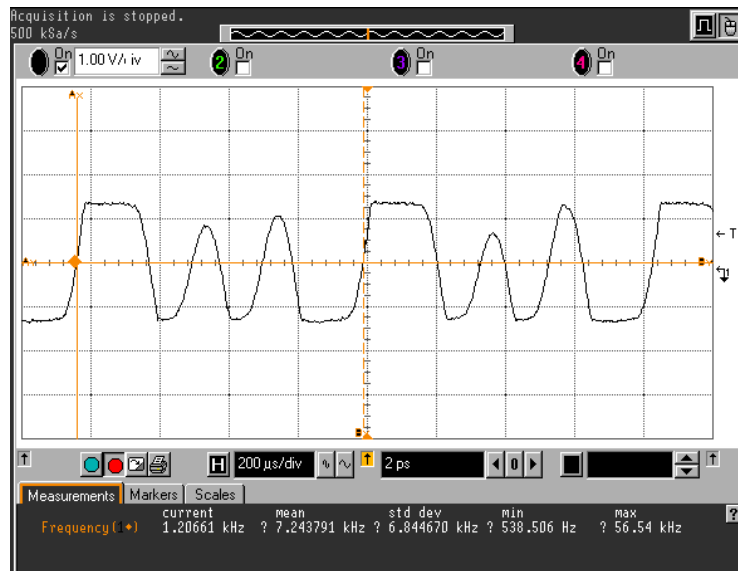

Figure A.16: Demodulated signal, -40 dBm RF. Pattern: 11001010

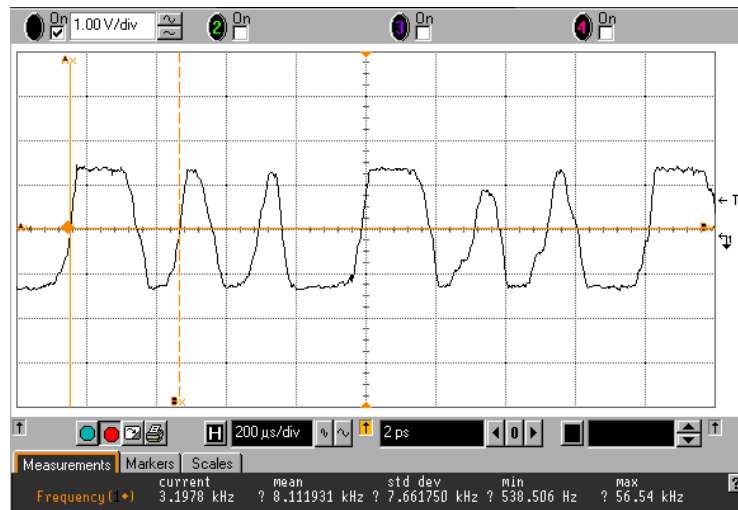

Figure A.17: Demodulated signal, -85 dBm RF. Pattern: 11001010

## Appendix B

# ASK-1 - Documentation

### B.1 Schematic

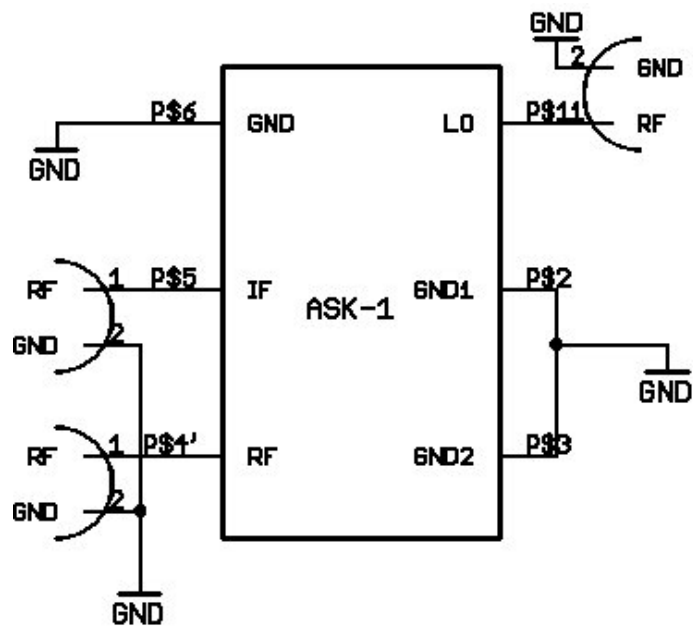

Figure B.1: ASK-1 Mixer, schematic

## B.2 Board Layout

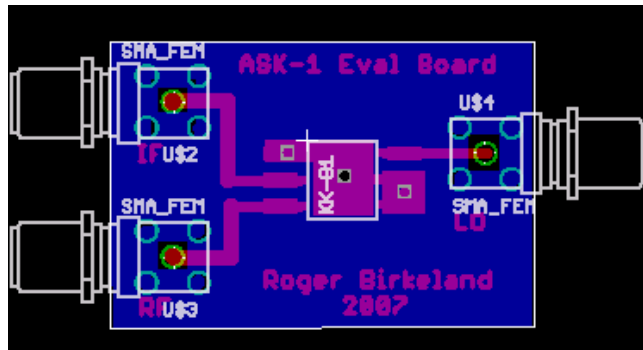

Figure B.2: ASK-1 Mixer, board

## B.3 Test Results

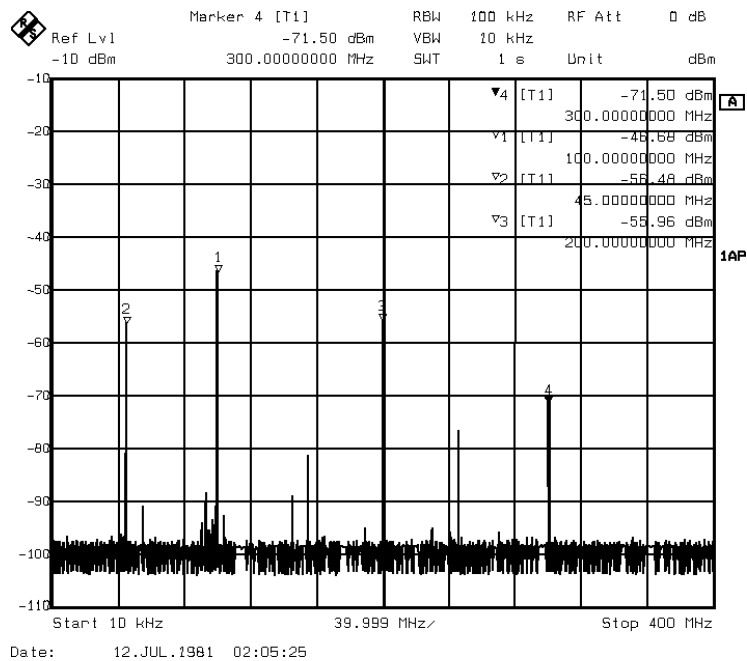

Figure B.3: Mixer output with 100 MHz LO, filtered

Figure B.3 showing filtered spectrum from the mixer with LO at 100 MHz. Filtered with PIF-40. RF level is -50 dBm, LO level is +7 dBm.

Figure B.4 showing filtered spectrum from the mixer with LO at 190 MHz. Filtered with PIF-40. RF level is -50 dBm, LO level is +7 dBm.

### B.3. TEST RESULTS

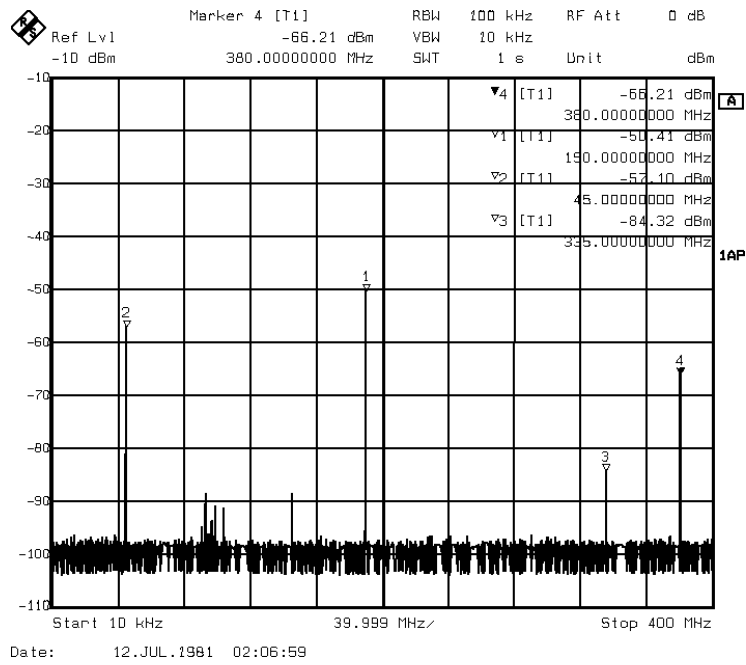

Figure B.4: Mixer output with 190 MHz LO, filtered

## Appendix C

### PIF-40 - Test Results

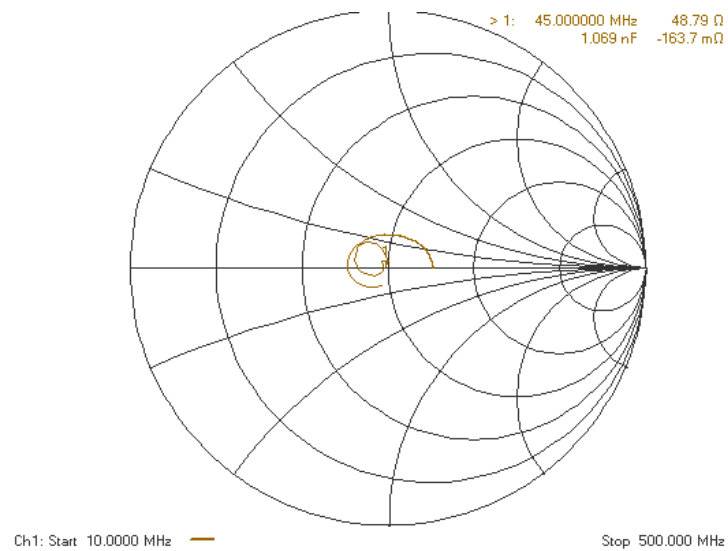

Figure C.1: PIF-40 S11

Both figures are from measurements done by Erik Narverud with a Agilent E8364B PNA vector network analyzer.



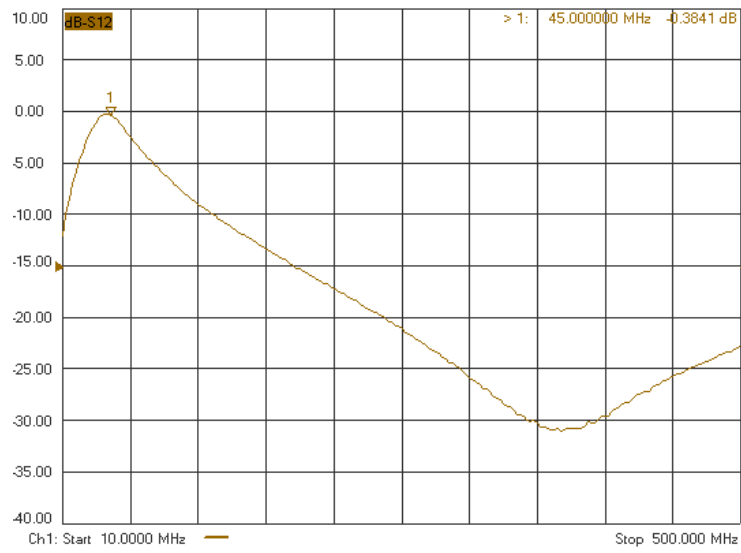

Figure C.2: PIF-40 S21

# Appendix D

## LFCN-160 - Documentation

### D.1 Schematic

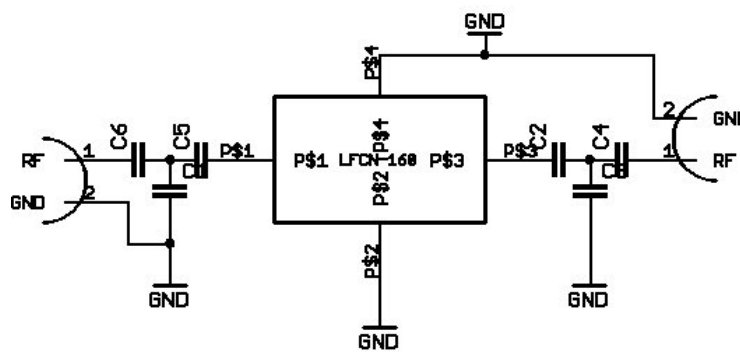

Figure D.1: LFCN-160 evaluation schematic

### D.2 Board Layout

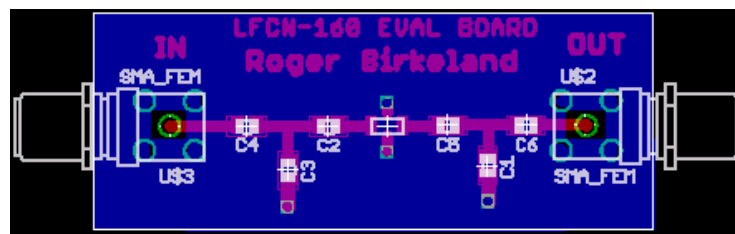
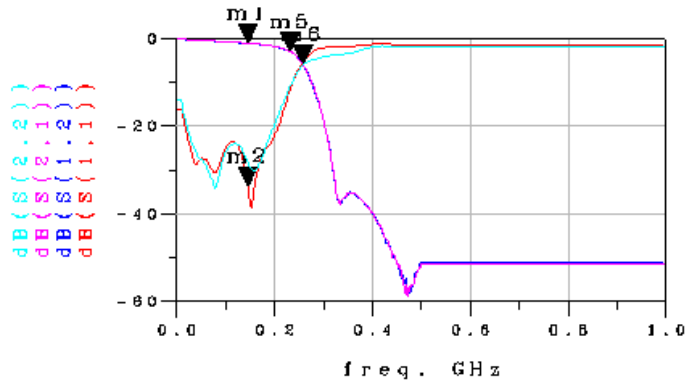

Figure D.2: LFCN-160 evaluation board

### D.3 Test Results



```
m1
freq = 145.0 MHz
dB ( S ( 1 , 2 ) ) = -1.089
```

```
m2
freq = 145.0 MHz
dB ( S ( 1 , 1 ) ) = -33.838
```

```
m5
freq = 233.0 MHz
dB ( S ( 1 , 2 ) ) = -3.040
```

```
m6
freq = 258.0 MHz
dB ( S ( 1 , 2 ) ) = -5.993
```

**Figure D.3:** S-parameters for LFCN-160. Marker 1 and 2 showing pass band data and marker 5 and 6 is showing insertion loss for the -3 dB and -6 dB frequencies respectively.

All measurements was done with the Agilent PNA. Data was exported as .s2p-files and imported into ADS. This was done to experiment with matching network for the circuit if needed.

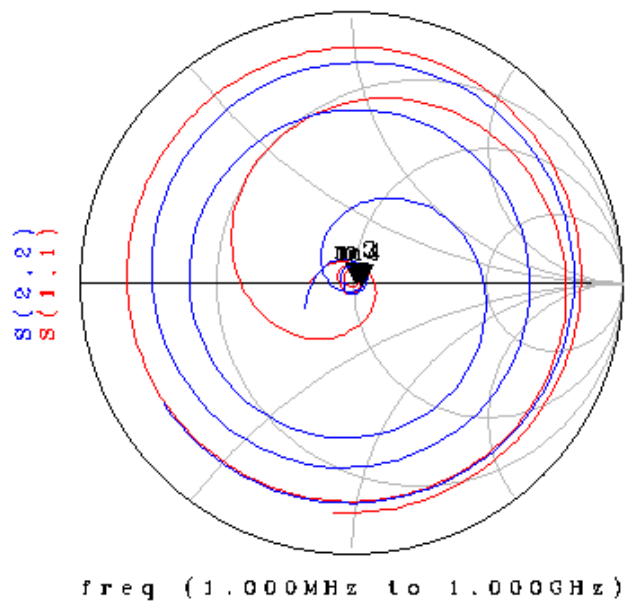

<b>m4</b> freq=145.0MHz $S(2,2)=0.039 / -19.476$ impedance = 53.846 - j1.420
---

<b>m3</b> freq=145.0MHz $S(1,1)=0.020 / -13.220$ impedance = 52.017 - j0.484
---

Figure D.4: Smith-chart for LFCN-160

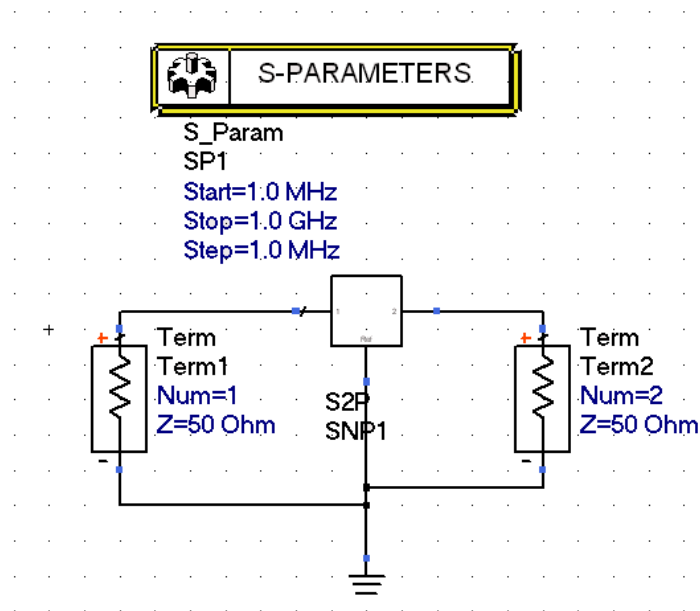

Figure D.5: ADS circuit for LFCN-160

# Appendix E

## RF2472 - Documentation

### E.1 Schematic

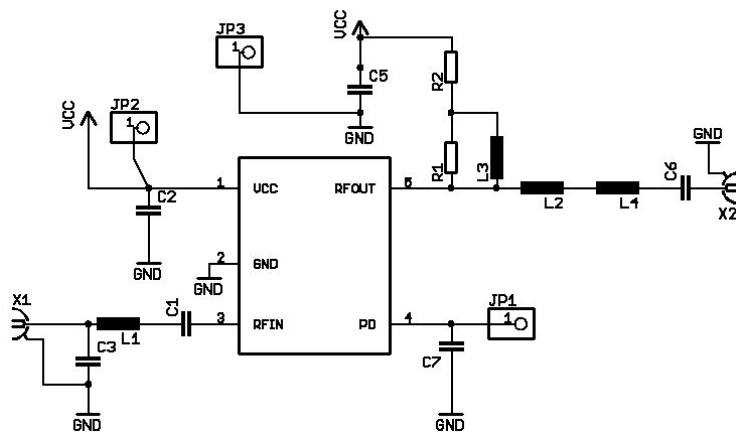

Figure E.1: RF2072 schematic

In the schematic, it is seen a few extra component than in the final circuit. They were put there to make room for matching components if needed. In the final circuit, the components explained below was used.

### E.2 Component Values

Component	Value
X1	SMA-contact for RF input
X2	SMA-contact for RF output
C1	100 nF
C2	22 nF
C3	4.7 pF
C5	3.3 pF
C6	100 nF
C7	22 nF
L1	N/A
L2	N/A
L3	220 nH
L4	N/A
R1	10 k $\Omega$
R2	N/A

Table E.1: RF2472 Component Values

### E.3 Board Layout

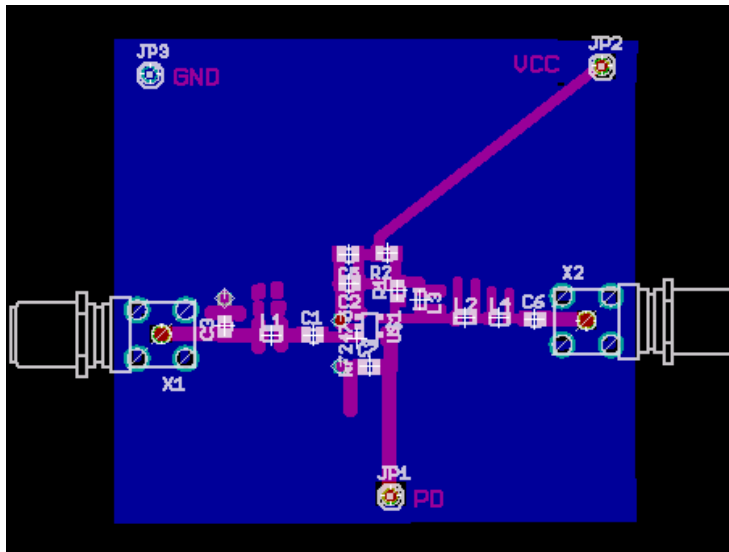

Figure E.2: RF2072 board

### E.4 Communication with RFMD

----- Original Message -----  
 From: "Sales-Support" <callcenter@rfmd.com>  
 To: <rogerbi@stud.ntnu.no>  
 Sent: Tuesday, April 17, 2007 6:03 PM

## APPENDIX E. RF2472 - DOCUMENTATION

---

Subject: RF2472 - Record 7222

Hello Roger,

The RF2472 is likely not the device that you need to be using in that frequency range. S-parameters will not help you match the device to 50 Ohms at that frequency, as it is SiGe. You will notice that the specification is focused on the upper frequency ranges.

The RF2361/RF2878 is likely a better chose. The RF2878 is the RoHS compliant version of the RF2361. The two parts are electrically the same and have the same characteristics. I've attached s-parameters for this device.

Best regards,  
Kenyon  
RFMD Sales-Support



# Appendix F

## HSWA-2 - Documentation

### F.1 Schematic

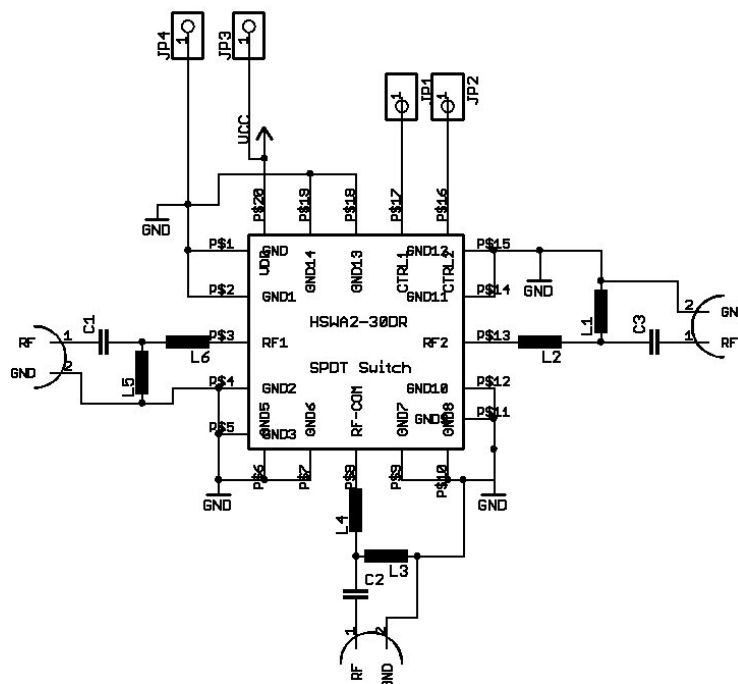

Figure F.1: HSWA-2 Schematic

## F.2 Board Layout

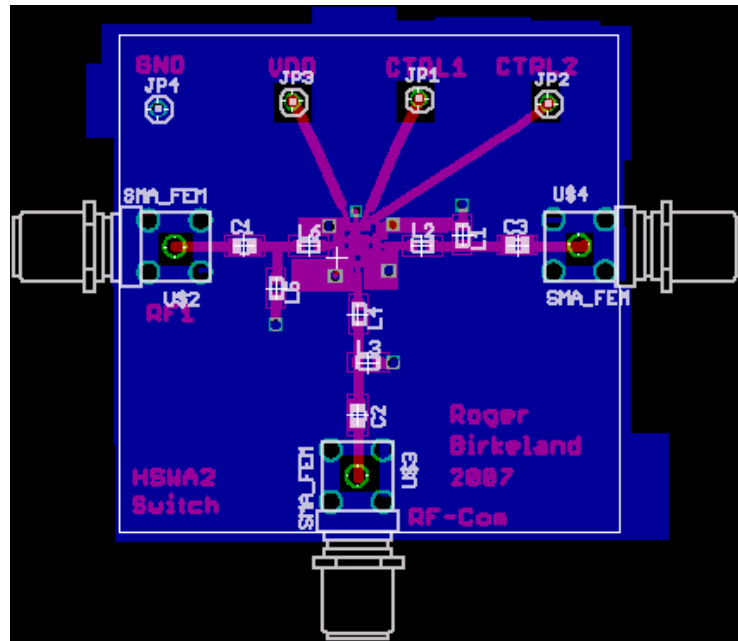

Figure F.2: HSWA-2 Board

## Appendix G

### RF2878 - Simulations

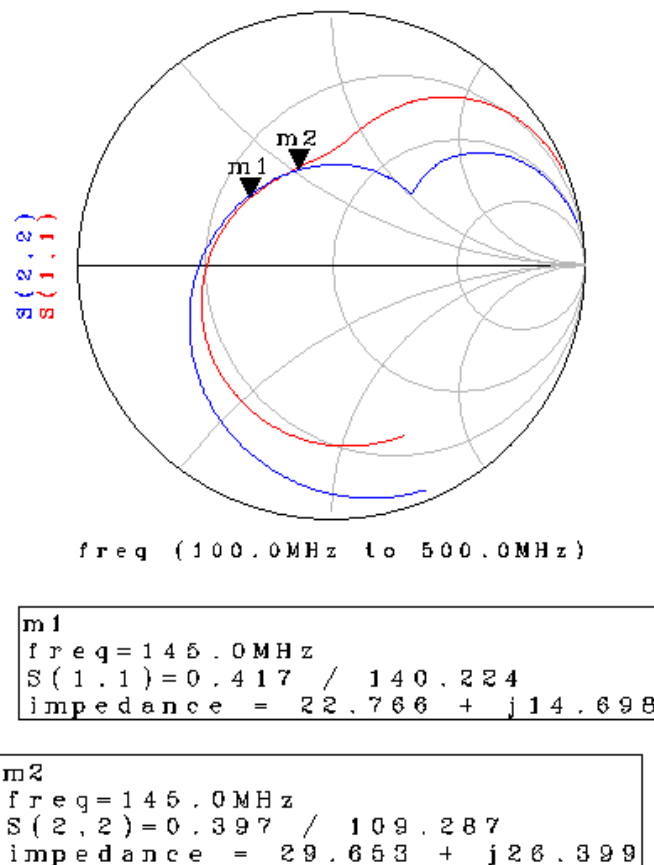
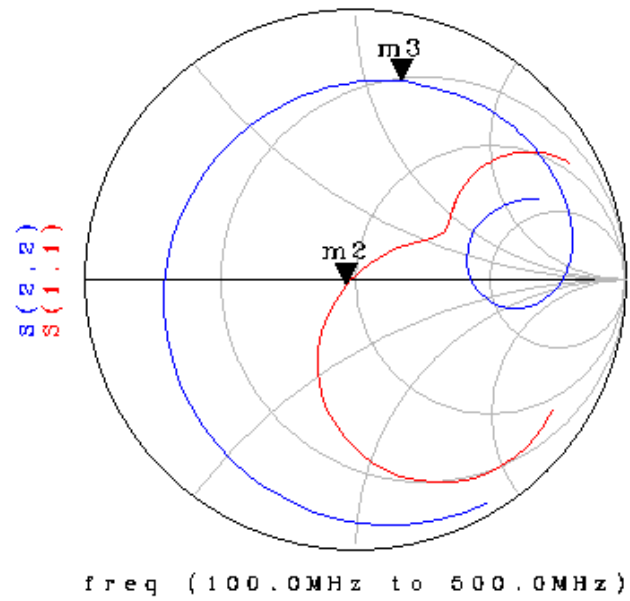

Figure G.1: ADS optimized, Smith diagram



<pre> m2 freq=145.0MHz S(1,1)=0.038 / -145.907 impedance = 46.895 - j2.009                     </pre>
---

<pre> m3 freq=145.0MHz S(2,2)=0.749 / 76.885 impedance = 17.960 + j59.744                     </pre>
--

Figure G.2: S11 matched, Smith diagram

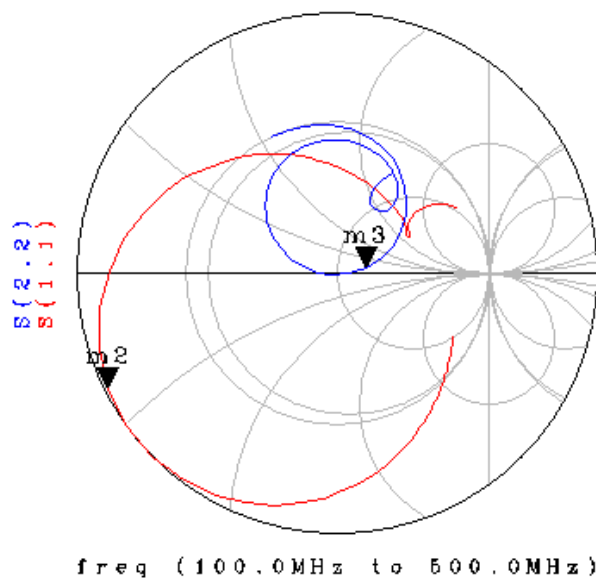

```

m2
freq=145.0MHz
S(1,1)=1.683 / -153.293
impedance = -13.393 - j11.060

```

```

m3
freq=145.0MHz
S(2,2)=0.196 / 11.246
impedance = 73.532 + j5.848

```

Figure G.3: S22 matched, Smith diagram

# Appendix H

## CMX909B - Documentation

### H.1 Schematic

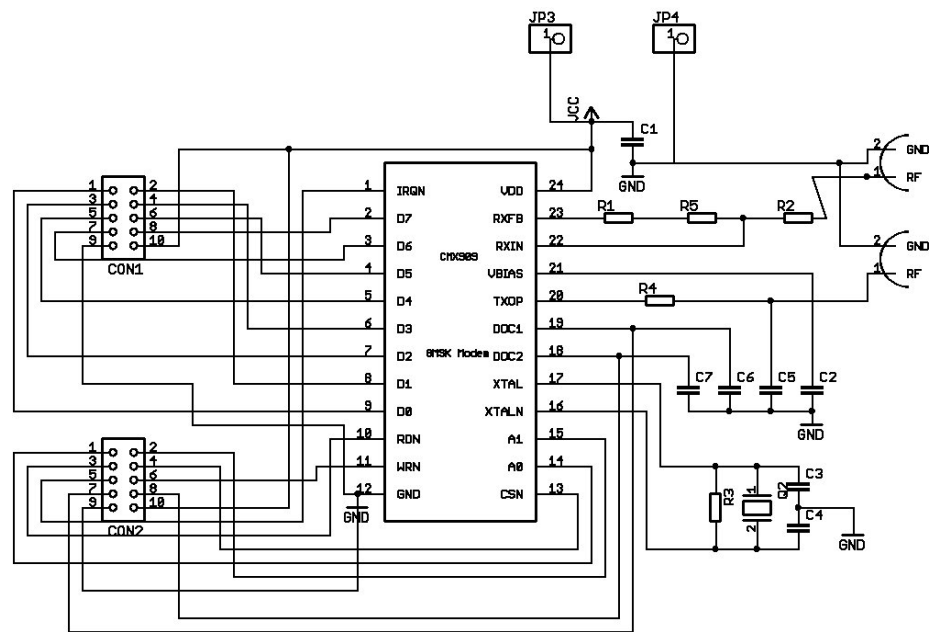

Figure H.1: CMX909 schematic

In figure H.1, note that R5 is put there to allow easier control of R1 when it is possible to put two resistors in series. Also, note that the output pins 18 and 19 not should be connected to the microcontroller; they are for the modems internal use only. This should be changed in further revisions of this board, or in a real application circuit.

Component	Value	Note
R1		See section 1.5.1.10 of the data sheet [11]
R2	100 k $\Omega$	
R3	1 M $\Omega$	
R4	100 k $\Omega$	See sec. 1.5.1.12
C1	0.1 $\mu$ F	
C2	0.1 $\mu$ F	
C3	33 pF	
C4	33 pF	
C5	354 pF	See sec. 1.5.1.12
C6	12 nF	
C7	12 nF	
X1	4.9152 MHz	

Table H.1: CMX909B Component Values

## H.2 Board Layout

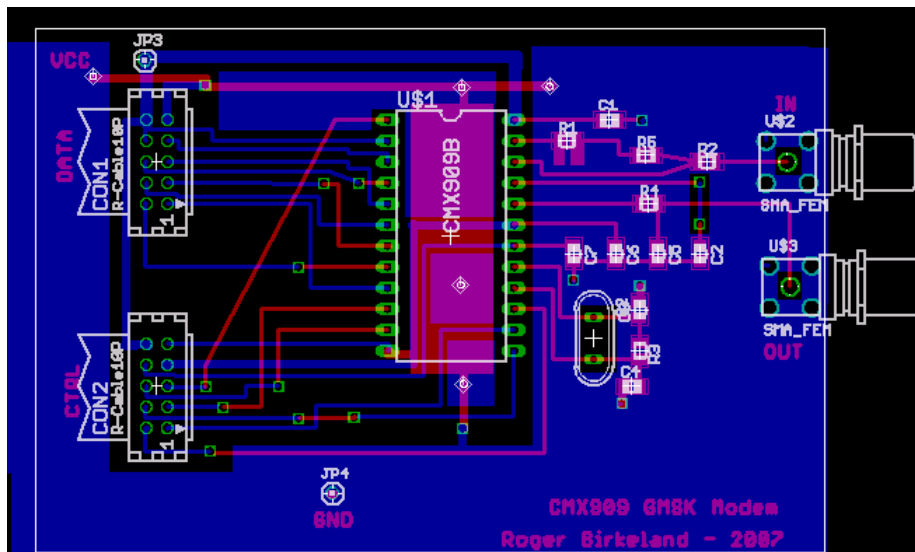

Figure H.2: CMX909 board

## H.3 Source Code

Listing H.1: Code for CMX909B MCU - CML\_909.c

```

1 #include <avr/io.h>
  #include <util/delay.h>
3 #include <avr/interrupt.h>
  #include <avr/pgmspace.h>

```

## APPENDIX H. CMX909B - DOCUMENTATION

---

```
5  #include "CML_909.h"
   #include "functions.h"
7
9  #define USART
   #include "usart.c"
11
   /*\
      *****
13  This is a program for the CML 909B GMSK-modem.
      A part of a engineering model/demonstrator for the \
         student satellite
15  project, StudSat at IET, spring 2007.
17  Author: Roger Birkeland
      Version:
19  Date: 15. May 2007
21  *****\
      */
23  void interrupt_init(void) {
      //enable timer interrupt
25  TIMSK |= (1<<TOIE1);
      //enable input capture interrupt
27  TIMSK |= (1<<TICIE1);
      sei(); //enable
29  }
31  int t = 0;
33  SIGNAL(SIG_OVERFLOW0) {
      _delay_us(0);
35  if (t == 0) {
          PORTD |= (1 << PD6);
37  PORTB |= (1 << PD6);
          t = 1;
39  }else {
          PORTD &= ~(1 << PD6);
41  PORTB &= ~(1 << PD6);
          t = 0;
43  }
      TCNT0 = 0x90;
45  }
47  void init_io(void) {
      //Set LED at PORTB
49  DDRB = 0xFF;
      DDRD = 0x00; //input
```



---

```

51 //Set the controllport:
M_CTRL_DDR = 0xFF;
53 //But configure the DOC-pins and IRQN as input...
M_CTRL_DDR &= ~(1<<M_CTRL_DOC1);
55 M_CTRL_DDR &= ~(1<<M_CTRL_DOC2);
M_CTRL_DDR &= ~(1<<M_CTRL_IRQN);
57 //Set data direction as input first...
M_DATA_DDR = 0x00;
59 }

61 void init_test(void) {
    TCCR0 = (0x00); //Timer clock = //system clock / //256
63 TIFR = 1<<TOV0; //Clear TOV0 / clear //pending \
    interrupts
    TIMSK = 1<<TOIE0; //Enable Timer0 //Overflow \
    Interrupt
65 DDRB = 0xFF; //Set Port B as /output
    DDRB |= (1 << PD6);
67 TCNT0 = 0x90;
    sei();
69 }

71 int main(void) {

73 //Setup timer for test...
    init_test();
75
    #ifdef USART
77 USART_Init();
    fdevopen(UT, test, 0);
79 #else
    #warning USART is OFF
81 #endif

83 init_io();

85 modem_init();

87 int tmp_statreg = modem_read(M_STATUSREG);
    PORTB = ~(tmp_statreg);
89
    if (tmp_statreg & (1 << 6)) { //the BFREE-bit is set
91     printf("\nDatabuffer_is_free,_waiting_for_data...\n" \
        );
        modem_send_data();
93 } else {
        printf("\nDo_one_more_reset...\n");
95     modem_init();
        }
97

```

---

```
    int ex = 1;
99    int debug = 0;

101    while(1) {
        if ((PIND == 0xFE) & (++ex < 100)) | debug) {
103            printf("\n\n.....Do_send_data.....\n");
            int tmp_statreg = modem_read(M_STATUSREG);
105            //    printf("\nReading done...\n");
            //    printf("%d", tmp_statreg);
107            PORTB = ~(tmp_statreg);
            if (tmp_statreg & (1 << 6)) { //the BFREE-bit is\
                set
109                printf("\n.....\nDatabuffer_is_free\
                    ,_waiting_for_data...\n");
                modem_send_data();
111            } else {
                printf("\nDo_one_more_reset...\n");
113                modem_init();
            }
115            _delay_ms(300);
            _delay_ms(300);
117            _delay_ms(300);
            _delay_ms(300);
119        }

121        if (PIND == 0xFD) {
            printf("\n\n.....Do_reset...\n");
123            modem_init();
        }

125        if (PIND == 0xFB) {
127            //Power down, and stop oscillator.
            printf("\n\n.....Do_power_down...\n");
129            modem_write(M_COMREG, M_TASK_PSBIXT);
            int turnoff = 0x00;
131            turnoff |= (1 << 3); //bit3
            modem_write(M_MODEREG, turnoff);
133        }

135        if (PIND == 0xF7) {
137            //Try to receive data...
            modem_get_data();
139        }

141        if (PIND == 0xEF) {
            //Send several data packages until reset.....
143            printf("\n\n.....Starting_send-loop.....\n\
                ");
            int tmp_statreg;
```

```

145     while (1) {
147         tmp_statreg = modem_read(M_STATUSREG);
148         PORTB = ~(tmp_statreg);
149         if (tmp_statreg & (1 << BFREE)) { //the BFREE-\
            bit is set
            //printf("\n.....\nDatabuffer is \
                free, waiting for data...\n");
151         modem_send_data();
            }else {
153             printf("\nWent_to_reset.....\n");
            modem_init();
155         }
            _delay_ms(25);
157     }
        }
159 }
}

```

---

**Listing H.2:** Code for CMX909B MCU - CML\_909.h

---

```

/*
2
4   Functions for CML 909 GMSK modem....
6   Author: Roger Birkeland
7   Version:
8   Date: 15. May 2007
10  -----Changelog-----
12  */
14
16  //Define mapping between the AVR and the 909 data ports\
    ...
18  //Data signals
19  # ifndef M_DATA
20  #   define M_DATA    PORTA
21  #   define M_DATA_DDR DDRA
22  #   define M_DATA_PIN PINA
23  #   define M_DATA_D0  PINA0
24  #   define M_DATA_D1  PINA1
25  #   define M_DATA_D2  PINA2
26  #   define M_DATA_D3  PINA3
27  #   define M_DATA_D4  PINA4
28  #   define M_DATA_D5  PINA5

```

## APPENDIX H. CMX909B - DOCUMENTATION

---

```

30 # define M_DATA_D6 PINA6
31 # define M_DATA_D7 PINA7
32 # endif

33
34 //Control signals
35 # ifndef M_CTRL
36 # define M_CTRL PORTC
37 # define M_CTRL_PIN PINC
38 # define M_CTRL_DDR DDRC
39 # define M_CTRL_PIN PINC
40 # define M_CTRL_A0 PINC0
41 # define M_CTRL_A1 PINC1
42 # define M_CTRL_RDN PINC2
43 # define M_CTRL_CSN PINC3
44 # define M_CTRL_IRQN PINC4
45 # define M_CTRL_WRN PINC5
46 # define M_CTRL_DOC1 PINC6
47 # define M_CTRL_DOC2 PINC7
48 # endif

49
50 //Tasks
51 # ifndef M_TASK_NULL
52 //common
53 # define M_TASK_NULL 0x00 //NULL
54 # define M_TASK_PSBIA 0x0E //Turn of bias during \
    power save
55 # define M_TASK_PSBIXT 0x0F //Turn of bias and xtal \
    during power save
56 # define M_TASK_RESET 0x07 //Reset Modem
57 //receive
58 # define M_TASK_SFH 0x01 //Search for Frame Head
59 # define M_TASK_R3H 0x02 //Read 3 byte Frame Head
60 # define M_TASK_RDB 0x03 //Read Data Block
61 # define M_TASK_SFS 0x04 //Search for Frame Sync
62 # define M_TASK_RSB 0x05 //Read Single Byte
63 # define M_TASK_LFSB 0x06 //Load Frame Sync Bytes
64 # define M_TASK_SFHZ 0x09 //SFH with zero errors
65 # define M_TASK_RSD 0x0B //Read Short Data Block
66 # define M_TASK_SFSZ 0x0C //SFS with Zero Errors
67 //transmit mode
68 # define M_TASK_T7H 0x01 //Transmit 7 byte Frame head
69 # define M_TASK_TDB 0x03 //Transmit Data Block
70 # define M_TASK_TQB 0x04 //Transmit 4 Bytes
71 # define M_TASK_TSB 0x05 //Transmit Single Byte
72 # define M_TASK_TSO 0x06 //Transmit Scrambler output
73 # define M_TASK_TSD 0x0B //Transmit Short Data Block
74 # endif
75
76
```

```

78 //Addresses
   # ifndef M_DATABUFFER
80 # define M_DATABUFFER 0x00
   # define M_COMREG 0x01
82 # define M_CTRLREG 0x02
   # define M_MODEREG 0x03
84 # define M_STATUSREG 0x01
   # define M_DQREG 0x02
86 # endif

88 //Bitnames...
   # ifndef IRQNEN
90 //command register
   # define AQLEV 0x06
92 # define AQBC 0x07
   # define EOP 0x05
94 # define ENV 0x04
   //control register
96 # define PLLBW 0x01
   # define LEVRES 0x03
98 # define DARA 0x04
   # define HILON 0x05
100 //mode register
   # define HIBW 0x00
102 # define HIXTL 0x01
   # define DQEN 0x02
104 # define PSAVE 0x03
   # define SCREN 0x04
106 # define TXRXN 0x05
   # define INVBIT 0x06
108 # define IRQNEN 0x07
   //status register
110 # define EOPENV 0x00

```

Listing H.3: Code for CMX909B MCU - *functions.c*

```

#include <avr/io.h>
2 #include <util/delay.h>
#include <avr/interrupt.h>
4 #include <avr/pgmspace.h>
#include "CML_909.h"
6 #include "functions.h"

8 /* General functions */

10 void flash_led(int pin) {
   unsigned char counter;
12   PORTB |= (1<<pin);
   counter = 0;

```

## APPENDIX H. CMX909B - DOCUMENTATION

---

```
14  while(counter++ != 5) {
15      _delay_loop_2(30000);
16  }
17  PORTB &= ~(1<<pin);
18  counter = 0;
19  while(counter++ != 5) {
20      _delay_loop_2(30000);
21  }
22  }

23
24  void off_led(int pin) {
25      unsigned char counter;
26      PORTB |= (1<<pin);
27      counter = 0;
28      while(counter++ != 5) {
29          _delay_loop_2(30000);
30      }
31  }
32
33  /*
34   * Functions for CML 909 GMSK modem....
35   * Author: Roger Birkeland
36   * Version:
37   * Date: 15. May 2007
38   */

39
40  void modem_write(unsigned int address, unsigned int data\
41                  ) {
42      //Set dataport datadirection as output
43      DDRA = 0xFF;
44      //Set address... WARNING: A0 and A1 MUST BE on PINx0 \
45          and PINx1 place repectivly...
46      M_CTRL = (M_CTRL & ~(0x03)) | (address);
47
48      _delay_loop_1(3);          //sync
49      M_DATA = data;
50      PORTB = ~data;
51      _delay_loop_1(3);          //sync
52
53      //Start writing...
54      M_CTRL &= ~(1<<M_CTRL_CSN); //chip select
55      _delay_loop_1(3);
56      M_CTRL &= ~(1<<M_CTRL_WRN); //enable write
57      _delay_loop_1(3);
58
59      //Finished...
60      M_CTRL |= (1<<M_CTRL_WRN); //end write
61      _delay_loop_1(3);
62      M_CTRL |= (1<<M_CTRL_CSN); //end select
63      _delay_loop_1(3);
```

---

```

62     //Reset adress...
64     M_CTRL = (M_CTRL & ~(0x03));

66     _delay_loop_1(3); //sync
68 }

68 int modem_read(unsigned int address) {
70     int data;
72     //Set datadirection input...
74     M_DATA = 0x00;
76     M_DATA_DDR = 0x00;
78     _delay_loop_1(3); //sync
80     //Set address... WARING: A0 and A1 MUST BE on PINx0 \
82     and PINx1 place repectivly...
84     M_CTRL = (M_CTRL & ~(0x03)) | (address);
86     _delay_loop_1(3); //sync
88     M_CTRL |= (1<<M_CTRL_WRN); //disable write
90     _delay_loop_1(3); //sync
92     M_CTRL &= ~(1<<M_CTRL_CSN); //chip select
94     _delay_loop_1(3);
96     M_CTRL &= ~(1<<M_CTRL_RDN); //enable read
98     _delay_loop_1(3);

100     data = PINA;
102     PORTB = data;
104     _delay_loop_1(3);
106     M_CTRL |= (1<<M_CTRL_RDN); //end read
108     _delay_loop_1(3);
110     M_CTRL |= (1<<M_CTRL_CSN); //end select
112     PORTB = data; //Display data on LEDs. For debugging \
114     only...
116     return data;
118 }

120 void modem_reset(void) {
122     modem_write(M_COMREG, M_TASK_RESET);
124 }

126 void modem_set_datarate(void) {
128     /* In this configuration, the modem clock is driven \
130     by a
132     4.9152 MHz xtal. The selected bit rate is 9600 bit/s\
134     .
136     This must written to control register and mode \
138     register.
140     CKDIV --> B7 = 0 | B6 = 1
142     HILON --> B5 = 1
144     DARA --> B4 = 0
146     */

```

---

## APPENDIX H. CMX909B - DOCUMENTATION

---

```

    int tmp_data = 0x00;
108 tmp_data |= (1 << 6) | (1 << 5) ; //B7 and B5
    modem_write(M_CTRLREG, tmp_data);
110 }

112 void modem_set_transmit(int en_scrambling) {
    /*
114     MODE_REG7 = 1 IRQNEN
        MODE_REG6 = 0 INVBIT
116     MODE_REG5 = 1 TXRXN (transmit)
        MODE_REG4 = 1 SCREN
118     MODE_REG1 = 0 HIXTL
    */
120 modem_set_datarate();
    //Need to use INVBIT together with a output buffer \
        since the CMX909 itself
122 //cannot drive the mixer.
    int tmp_data = 0x00;
124 if (en_scrambling) {
        tmp_data |= (1 << IRQNEN) | (1 << TXRXN) | (1 << \
            SCREN);
126 } else {
        tmp_data |= (1 << IRQNEN) | (1 << TXRXN) | (1 << \
            INVBIT);
128 }
    modem_write(M_MODEREG, tmp_data);
130 }

132 void modem_init(void) {
    PORTC = 0x00;
134 M_CTRL |= (1 << M_CTRL_RDN);
    M_CTRL |= (1 << M_CTRL_WRN);
136 M_CTRL |= (1 << M_CTRL_CSN);
    modem_reset();
138 }

140 void modem_set_receive(int en_scrambling) {
142     /*
        MODE_REG7 = 1 IRQNEN
144     MODE_REG6 = 0 INVBIT
        MODE_REG5 = 0 TXRXN (receive)
146     MODE_REG4 = 1 SCREN
        MODE_REG1 = 0 HIXTL
148     */
    int tmp_data = 0x00;
150 if (en_scrambling) {
        tmp_data |= (1 << IRQNEN) | (1 << SCREN) | (0 << \
            DQEN); //with scrambling
152 } else {
```



```

    tmp_data |= (1 << IRQEN) | (0 << DQEN);          /\
        without scrambling
154 }
    modem_write(M_MODEREG, tmp_data);
156 }

158 void modem_set_datarate_receive(void) {
    /*
160     M_CTRLREG7 = CKDIV    0
162     M_CTRLREG6 = CKDIV    1
164     M_CTRLREG5 = HILON    1 //See p. 26 in datasheet
166     M_CTRLREG4 = DARA    0
168     M_CTRLREG3 = LEVRES   0 //Peak Averaging. See p. 27 in\
        datasheet.
170     M_CTRLREG2 = LEVRES   1 //Peak Averaging. See p. 27 in\
        datasheet.
172     M_CTRLREG1 = PLLBW    1
174     M_CTRLREG0 = PLLBW    0
    */
    int tmp_ctrl = 0x00;
    tmp_ctrl |= (1 << 6) | (1 << HILON) | (1 << LEVRES) | \
        (1 << 1);
    modem_write(M_CTRLREG, tmp_ctrl);
}

174 void modem_get_data() {
    int en_scrambling = 0;
176     int tmp_data = 0x00;
178     int tmp_status;
180     int frame_head[2];
182     int frame_data[2];
    modem_reset();
    modem_set_datarate_receive();
    modem_set_receive(en_scrambling);

184     //must do some RSSI-measurement....
186     //assume allways carrier....

    _delay_us(100); //about 2 bit times
188     //Load frame-sync bytes...
    tmp_data = 0xCC;
190     modem_write(M_DATA, tmp_data);
192     modem_write(M_DATA, tmp_data);

    //Task; LFSB, and set M_COMREG7 (AQBC) and set \
        M_COMREG6 (AQLEV)
194     tmp_data = 0x00;
196     tmp_data = M_TASK_LFSB;
    tmp_data |= (1 << AQLEV) | (1 << AQBC);
    modem_write(M_COMREG, tmp_data);

```

```
198 //Assume low IRQ-line... TODO: verify!!
200 _delay_ms(30);
200 _delay_ms(30);
202
204 printf("\nEntering_ISR_1:\n");
204 if (modem_RX_ISR(0)) {
206     //_delay_us(100); //something like 12 bit periodes\
206     ....
206     _delay_ms(30);
208
208     modem_write(M_COMREG,M_TASK_SFH);
210     //assume low IRQN
210     //_delay_ms(30);
212
212     printf("\nModem_is_trying_to_find_frame_head....\n\nEntering_ISR_2:\n");
214     if (modem_RX_ISR(1)) {
214         _delay_ms(300);
216
216         tmp_status = modem_read(M_STATUSREG);
218         printf("\nStatus_register_after_ISR_2:_");
218         printf("%d",tmp_status);
220
220         frame_head[0] = modem_read(M_DATABUFFER);
222         frame_head[1] = modem_read(M_DATABUFFER);
224
224         modem_write(M_COMREG,M_TASK_RSB);
226
226         tmp_status = modem_read(M_STATUSREG);
226         //_printf("\nStatus register M_TASK_RSB: ");
228         //_printf("%d",tmp_status);
228         printf("\nData...\n");
230         printf("%X",frame_head[0]);
230         printf("\nData...\n");
232         printf("%X",frame_head[1]);
232         //assume low IRQN
234         //_delay_us(200);
236
236         tmp_status = modem_read(M_STATUSREG);
236         printf("\nStatus_register_before_ISR_3_");
238         printf("%d",tmp_status);
238         //_printf("\nEntering ISR 3:\n");
240         if (modem_RX_ISR(2)) {
240             if (tmp_status & CRCFEC) {
242                 printf("\nCRC-error...read_data_anyway...\n");
242             }
244             int i = 0;
244             for (i=0;i<19;i++) {
```

```

246         frame_data[i] = modem_read(M_DATABUFFER);
           printf("\nPackage_data, X:");
248         printf("%d", i);
           printf(":");
250         printf("%X", frame_data[i]);
           //printf("\n");
252     }
254 }
256 }
258 }

260 int modem_RX_ISR(int slow) {
    // ISR-----
262     int tmp_status;
    int tmp_dq;
264     int x = 0;
    int ret = 0;
266     tmp_status = modem_read(M_STATUSREG);
    /*
268     printf("\nISR: Statusreg, X : ");
    printf("%X", tmp_status);
270     printf("\n");
    */
272     if (slow == 2) {
        _delay_ms(30);
274         _delay_ms(30);
        _delay_ms(30);
276         _delay_ms(30);
        _delay_ms(30);
278         _delay_ms(30);
        tmp_status = modem_read(M_STATUSREG);
280         printf("\nISR:_Statusreg_-_while, X:");
        printf("%X", tmp_status);
282         printf("\n");
        tmp_dq = modem_read(M_DQREG);
284         printf("\n_Dataquality:");
        printf("%d", tmp_dq);
286         printf("\n");
    } else {
288         while ((!(tmp_status & (1 << IRQ)) & (x < 10000)) {
            tmp_status = modem_read(M_STATUSREG);
290             if ((x % 100 == 0)) {
                printf("\nIRQ_is_low_(in_RX)");
292                 printf("x:");
                printf("%d", x);
                printf("\nISR:_Statusreg_-_while, X:");
294                 printf("%X", tmp_status);

```

```
296     tmp_dq = modem_read(M_DQREG);
      printf("\n_Dataquality:_");
298     printf("%d",tmp_dq);
      }
300     if (slow == 1) { _delay_ms(300);}
      x++;
302   }
  }
304  if (tmp_status & (1 << DIBOVF)) {
    printf("\nDIBOVF_in_RX\n");
306    ret = 0;
  }else if (!(tmp_status & (1 << BFREE))) {
308    printf("\nBFREE_is_not_set!!\n");
    ret = 0;
310  }else if (x > 990) {
    printf("\nCan't_wait_that_long,_nothing_found...\n")\
      ;
312    ret = 0;
  }else {
314    ret = 1;
  }
316  return ret;
}
318
void modem_send_data() {
320  int tmp_status = 0x00;
  int en_scrambling = 0;
322  modem_set_transmit(en_scrambling);
  //Modem is ready....
324  //Write frame head
  tmp_status = modem_read(M_STATUSREG);
326  modem_write(M_DATABUFFER,0xCC); //1100110 - sync
  modem_write(M_DATABUFFER,0xCC); //1100110 - sync
328  modem_write(M_DATABUFFER,0x11); //shuld indicate frame\
    number
  modem_write(M_DATABUFFER,0x11); //shuld indicate frame\
    number
330  modem_write(M_DATABUFFER,0x44); //some control data...
  modem_write(M_DATABUFFER,0x44); //some control data...
332  _delay_loop_1(3);
  modem_write(M_COMREG,M_TASK_T7H);
334
  while ((M_CTRL_PIN & (1 << M_CTRL_IRQN)) {
336    printf("waiting....on_IRQ_1\n");
  }
  //delay_ms(300);
338  if (!(M_CTRL_PIN & (1 << M_CTRL_IRQN)) {
340    //printf("Can send data...\n");
    _delay_ms(4);//DO NOT REMOVE! Needed....
342    tmp_status = modem_read(M_STATUSREG);
```

---

```

344 //printf("\nRead statusreg before send frame: ");
//printf("%d",tmp_status);
if (tmp_status & (1 << 5)) { //is IBEMPTY set..?
346 printf("\nError...IBEMPTY....abort..1\n");
} else if (!(tmp_status & (1 << 6))) { //is BFREE set\
..?
348 printf("\nError...BFREE...abort..1\n");
} else { //oki...
350 //18 bytes
modem_write(M_DATABUFFER,0xCB);
352 modem_write(M_DATABUFFER,0xCB);
modem_write(M_DATABUFFER,0xCB);
354 modem_write(M_DATABUFFER,0xCB);
modem_write(M_DATABUFFER,0xCB);
356 modem_write(M_DATABUFFER,0xCB);
modem_write(M_DATABUFFER,0xAA);
358 modem_write(M_DATABUFFER,0x55);
modem_write(M_DATABUFFER,0xCB);
360 modem_write(M_DATABUFFER,0x55);
modem_write(M_DATABUFFER,0xCB);
362 modem_write(M_DATABUFFER,0xCB);
modem_write(M_DATABUFFER,0xCB);
364 modem_write(M_DATABUFFER,0xCB);
modem_write(M_DATABUFFER,0xF0);
366 modem_write(M_DATABUFFER,0xCB);
modem_write(M_DATABUFFER,0xF0);
368 modem_write(M_DATABUFFER,0xCB);
_delay_ms(1);
370 modem_write(M_COMREG,M_TASK_TDB);
while ((M_CTRL & (1 << M_CTRL_IRQN)) {
372 printf("waiting....on_IRQ_-2\n");
}
374 _delay_ms(3);
//_delay_ms(300);
376 tmp_status = modem_read(M_STATUSREG);
//printf("\nRead statusreg before send hang byte: \
");
378 //printf("%d",tmp_status);
if (!(tmp_status & (1 << 6))) { //is BFREE set..?
380 printf("\nError...NOT_BFREE...abort..2\n");
} else if (tmp_status & (1 << 5)) { //is IBEMPTY \
set..?
382 printf("\nError...IBEMPTY....abort..2\n");
} else { //oki...
384 //write hangbyte...
modem_write(M_DATABUFFER,0xCC);
386 //uswrite M_TASK_TSB
modem_write(M_COMREG,M_TASK_TSB);
388 //printf("\nDone...Find transmission on TX-line\
...\n");

```

---

```
390     }  
    }  
392 }  
}
```

---

**Listing H.4:** Code for CMX909B MCU - *functions.h*

---

```
void flash_led(int pin);  
2 void off_led(int pin);  
void interrupt_init(void);  
4 void init_io(void);  
void modem_write(unsigned int address, unsigned int data\  
    );  
6 void modem_reset(void);  
void modem_set_datarate(void);  
8 void modem_set_transmit(int en_scrambling);  
void modem_init(void);  
10 void modem_getstatus(void);  
int modem_read(unsigned int address);  
12 void modem_send_data(void);  
int modem_RX_ISR(int slow);  
14 void modem_get_data(void);
```

---

## **Appendix I**

# **System Design Review**

Agenda, report and the presentations from the System Design Review are found in this chapter in the stated order. The last pages, contain a further description from UiO regarding their suggestion for a payload.

# Innkalling til «System Design Review»

Stad: Rom F404, Elektrobygget Gløshaugen, NTNU

Tid: 1000 – 1430 (merk at vi startar på heil time...)

## Bakgrunn

Prosjektet er igangsett for å lage ein oppfølgjar til NCUBE, som var eit samarbeidsprosjekt mellom fleire universitet og høgskular i Noreg. Det nye prosjektet vil vere lokalt styrt ved NTNU for å prøve å halde det meir oversiktleg. Prosjektet vil vere med på NAROM sin studentsatellitt-konkurranse for å få tildelt resursar til oppskyting og testing. Det er venta at NAROM kjem med ei ny utlysing til denne konkurransen i løpet av våren.

Denne møtet vert det første større møtet i samband med satellittprosjektet ved NTNU. På møtet vert prosjektet presantert, saman med den foreløbige tekniske spesifikasjonen for kvart delsystem. I tillegg vert diplomoppgåvene som er under arbeid i vår gjennomgått i meir detalj.

Formålet med møtet er å kvalitetsikre arbeidet som er gjort, deltakarane på møtet vert invitert til å komme med innspel og kritikk til det som vert gjennomgått.

## Agenda

10.00 – 10.15	Introduksjon
10.20 – 12.00	Gjennomgang av spesifikasjon (sjå liste under)
12.00 – 12.30	Lunsj
12.30 – 14.00	Individuell gjennomgang av oppgåver
14.00 – 14.30	Eventuelt (PR, rekruttering)

### **Før lunsj:**

Mechanical

Thermal

Payload (Kamera, Langmuirprobe)

Power

Data (OBDH)

### **Etter lunsj:**

Communication

ADCS

Gi gjerne tilbakemelding om du kan komme eller ikkje.

Vel møtt!

Med helsing,

Elisabeth, Erik, Kjell, Jan og Roger



## **Referat System Review, 13 mars 2007, rom F404, Gløshaugen**

Deltakrar:

Erik Narverud, Jan Rohde, Kjell Rohde, Roger Birkeland, Elisabeth Blom (studentar)  
Håkon Indseth, Eystein Sedberg (Norspace)  
Arne Pedersen (UiO)  
Rune Sandbakken (Conax)  
Odd Gutteberg, Jan Tommy Gravdahl, Morten Olavsbråten, Jon Anders Aas (faglærarar)  
Torgrim Gjelsvik (Sintef)  
Lasse Borja (IET)  
Sverre Hendset, Bjørn B. Larsen (ITK og IET, før lunch)

## **Agenda**

Referat System Review, 13 mars 2007, rom F404, Gløshaugen.....	1
Introduksjon.....	2
Erik Narverud: Mekanisk system.....	2
Roger Birkeland: Termisk system.....	2
Kjell Rohde: Power Management.....	3
Jan Rohde: OBDH (On Board Data Handling).....	4
Arne Pedersen, UiO: Langmuirprobe .....	6
Jan og Kjell Rohde, ITK: ADCS, Sensorar, Kalmanfilter og aktuatorar.....	7
Roger Birkeland, IET: VHF TTC-radio, Hardware.....	7
Erik Narverud, IET: UHF nyttelastradio.....	7
Avsluttende ord.....	8

## Introduksjon

Sjå vedlagt presentasjon, vedlegg 0.

Odd Gutteberg ynskta velkommen og gjekk gjennom bakgrunn for prosjektet. Sjå introduksjonspresentasjon.

Roger Birkeland presanterte ei oversikt over prosjektet, meir bakgrunn, mål og korleis gjennomføring er tenkt.

## Erik Narverud: Mekanisk system

Sjå vedlagt presentasjon, vedlegg 1.

Spørsmål og kommentarar:

*Rune Sandbakken:* Er metoden for innfesting og plassering av komponentar ein standard struktur?

*Eystein Sedberg:* Må få analysert og testa mekanisk struktur, jo før jo heller. Dette er ikkje ei lita oppgåve!

Utfordring når det gjeld antenne:

- Folding
- Oppskyting
- Ikkje øydelegge noko anna (vibrering som går utover solceller)

*Rune Sandbakken:* Kontrollere massebudsjettet fortløpande. Kontrollere at ein ikkje går opp mot kritiske grenser.

*Arne Pedersen:* Kan ein prøve å få hjelp til tilbakemelding/vurdering frå ESA? Dei har program som støttar studentprosjekt. Få kommentarar på design, marginar på system med meir. Kva med mekanisk testing? Skal det gjerast lokalt eller kanskje på Kjeller.

*Odd Gutteberg:* Vi har tidlegare studentar hos ESA vi kunne ta kontakt med.

*Erik:* FFI har sagt seg villige til å vere med på testing.

Grunngiving for frekvensvalg: Arv etter nCube, det er desse vi sansynlegvis får tildelt frå NAROM. Kan søke om eigne. Då vert andre, kanskje meir praktiske, antennetypar aktuelle.

*Lasse Borja:* Har prototype på foldbar patch, men den vil kanskje bli vel kompleks i dette prosjektet.

## Roger Birkeland: Termisk system

Sjå vedlagt presentasjon, vedlegg 2

Det er generelle krav til struktur og komponenter. Kun passiv regulering. Ca 17 C likevektstemperatur med 2-5W intern varmeproduksjon.

40 minutt eklipse gir ca -25 C.

Kommentarer:

- Rotasjon av satellitten er viktig så ikkje ei side blir varm medan andre vert avkjølte.
- Ei omfattande termisk analyse er ynskelig og svært viktig.
- Torgrim Gjelsvik: Til dømes bruke oppvaring frå forsterkarar til oppvarming av batteribank.
- Rune Sandbakken/Arne Pedersen: Få hjelp frå ESA? Dei har truleg utstyr og programvare til dette. Bruke ekstern hjelp er viktig!

## **Kjell Rohde: Power Management**

Sjå vedlagt presentasjon, vedlegg 3

Tre oppgåver:

- Ladeovervaking
- Overvåke effektbruk
- Prediktere effektbruk

Forslag til prioritetsliste: Stenge ned system om det ikkje er nok power i satellitten.

1. Lading
2. ADCS
3. ODBH
4. Service Transmission
5. Payload
6. Payload Transmission

*Eystein Sedberg:* Kvifor står Service Transmission så langt ned? Det er jo definert høgt opp mellom mission goals. Kva skjer om HW eller SW feilar? Må ha ein slags safe-mode. Kva om de-tumbling ikkje fungerer?

*Kjell:* Denne lista er når satellitten er i drift, dette vil avvike frå initiell operasjon. Må gi de-tumbling ei maksimum-tid.

*Torgrim Gjelsvik:* Power management bør vere støttesystem til OBDH, slik at OBDH er master og tek avgjersle om opp/ned-kobling.

Erik presanterar effektbudsjett. (sjå vedlegg)

*Lasse Borja:* Ver klar over at verknadsgrad på IFE-cellene er best-case 10% (Si).

*Erik:* Målet er GaAs! Vi jobbar med å skaffe dette.

*Rune Sandbakken:* Kva batteri er det tenkt brukt?

*Erik:* Li-Ion polymerceller fra Danionics har blitt benyttet i tidligere prosjekter, og oppfyller de ønskede spesifikasjonene. Disse eller lignende bør vurderes.

## **Jan Rohde: OBDH (On Board Data Handling)**

Sjå vedlagt presantasjon, vedlegg 4

Vi vil gå for distribuert bussløyning framfor sentralisert FCU (Flight Computer Unit). Kan tole fleire feil på den måten; Ikkje alle systema i satellitten vil feile om FCU feilar. OBDH kan få power management til å kutte straum til eit system om det sluttar å fungere.

Reloading av programvare kan vere noko å tenkje på, men det er kompleks.

Det kan vere ein fordel å tilretteleggje så til dømes ein av radioane kan overta som master på bussen (I2C) om OBDH feilar skikkeleg. Kompleksitet er også her eit problem.

*Håkon Indseth:* Vurder Loop-back. Direkte kommunikasjon mellom radio sendar/mottakar.

*Jan:* Dette er ei kompleks oppgåve, mykje arbeid står igjen.

*Kjell:* Bit-flips i minne på grunn av høg-energistråling kan vere eit problem. Kan ha ei algoritme som køyrer kontinuerleg som sjekkar pariteten til minne.

*Lasse Borja:* Atmel har rad-hard 8MB til 1700 dollar... Det er dyrt.

*Lasse Borja:* Kva er estimatet på bit-flips? På "denne bana". (Bana vår er ukjent pr. i dag)

*Erik:* Det finst data på dette, men vi har ikkje dei konkrete. Område som den Søramerikanske anomali gjev problem, sannsynlegheit for single-event-upset, latchup eller bit-flip er ikkje lik for alle baneposisjonar. Kan ha ein bootloader-prosedyre i minne som vert kontrollert, så ein kan omprogrammere mikrokontrollerar om dei feilar.

*Jan Tommy Gravdal:* Bit-flips var vurdert som lite sannsynleg for nCube, med tanke på levetid (relativt kort) på satellitten.

*Eystein Sedberg:* Må ha ein ting på ein radio med minst mogleg elektronikk som kan køyre power down og power up på heile systemet, om ein får latch-up i CMOS-kretsar. MEN: den må ikkje kunne låse seg så den slår av og på power heile tida!

*Bjørn B. Larsen:* Kan bruke Rad-Hard komponentar til ei slik løysing. Kanskje verdt å spandere pengar på det.

*Erik:* Vi vil bruke Rad-Hard RX/TX-switch. Det er ein viktig komponent som ikkje toler å feile!

*Torgrim Gjelsvik:* Det er ein fin balanse mellom anarki og meir eit bestemt styre. Fleire masterar kan vere rissikabelt. Det er mykje spennande som kan skje om ein kan sykle power frå radiomottakar. Mykje spennande som kan skje!

*Eystein Sedberg:* Må ha fokus på det som er viktig. Når Dagrevyen melder om at satellitten er oppe, så er nyhenda at vi har fått radiokontakt. Ha minst mogleg nyttelast ombord. Få inn redundans i alle ledd. Begrens talet flotte funksjonar. Analyser heile satellitten med tanke på redundans. Analyser kvar komponent i satellitten for å sjå kva konsekvens ein feil får. FMECA-analyse.

*Odd Gutteberg:* Dette (tid, og kapasitet til gode feilanalyser) er problemet med studentsatellittprosjekt. Studentane har berre eit år på å designe, produsere og teste.

*Eystein Sedberg:* Analyse kan godt gjerast av nye studentar med friske auge!

*Lasse Borja:* "Blind og dum satellitt". Ta med 200 gram autonom hardware som kan svare på ping og gi ein temperatur. Heilt andre frekvensar? 2,4 eller 5,6 GHz patch-antenne til dømes?

*Jan Tommy Gravdal:* Hugs at målet er å eit ping! Dette var suksesskriteret frå nCube.

*Eystein Sedberg:* Viktig med analyse i alle ledd. Worstcase-analyse. Temperaturanalyse og termisk sykling må testast. Ikkje tenk på levetid i dette prosjektet. Kan få mange analysene ved å test modellar. FMECA på kritiske element. I visse delar av satellitten må vi ikkje ha moglegheit for feil. (Døme: ei buss-linje som er avkobra til jord --> Er den avkobra med ein kondensator som kortsluttar, dør bussen. Må ha to kondensatorar i serie!)

*Lasse Borja:* Kan Norspace gi ut eit eksempel på ei slik analyse? Er det proprietære system/programvare?

*Eystein Sedberg:* Dette er ikkje store og avanserte program. Ein ser på kvar komponent. Feilmodus: komponenten kan ha to feiltilstandar; "short"/"open". Vurdere kva skjer i kvart av dei to tilfella, kva konsekvensar ein slik feil får. Målet er å beskytte seg mot single point of failures.

*Lasse Borja:* Kan studentar komme ned til Norspace for å sjå på slike prosessar? Opprett dialog med Norspace for å få gjennomført dette!

*Eystein Sedberg:* Døme på system der ein ikkje vil ha single point of failure er powersystem og kommandomottakar. Ein løysing er å ha to radioar, to batteri i parallell, diode i mellom batteria så det eine ikkje kan kortslutte det andre osv.

Det er bra å lage ein engineering-modell. Testing, testing og testing er viktig. Om denne modellen blir testa skikkeleg, kan ein løyse designproblem tidleg. Når satellitten er montert, testa og skrudd saman, så er det ikkje lov med "skal bare ordne litt"... Ein kan ikkje opne satellitten for å gjere endringar på eit delsystem. Gjere ein det, må heile satellitten testast pånytt etterpå!

- Fokuser på primærfunksjon
- FMECA
- Redundans

- Test sluttproduktet

*Erik:* Vakuumtest er eit krav i spesifikasjonen. CalPoly har slike testar som vert utført av deira personell før launch. Vi vil også gjere slike testar sjølv. Både på engineeringmodellar og sluttprodukt.

*Lasse Borja:* CalPoly sine testar handlar om å sjå at alt står fast, ingen lause skruar m.m. samt utgassing. Testane er for å sjå at ein ikkje skadar moderfartøyet eller andre satellitar ombord. Ein testar ikkje *funksjonalitet* der. Det må vi gjere sjølv.

*Odd Gutteberg:* Kva med testrapportane frå nCube, dei kunne vore nyttig å sett. Dei har vi ikkje.

*Arne Pedersen:* Test og test er bra, men testar må gå lenge. Termisk sykling tildømes.

*Eystein Sedberg:* Typisk testprogram:

- Vibrasjon
- Termisk sykling med overvåking. Kan avdekke sprekkar, dårlege loddepunkt osv.

Instituttet Romfysikk i Kiruna: Dei har noko dei kallar ein solsimulator. (Eigentleg eit termisk vakuum-kammer).

*Torgrim Gjelsvik:* Kva skjer før og under launch med termisk og power? Kva er det termiske miljøet då? Vil batteri stå lenge og bli utlada?

*Erik:* Fysisk miljø under launch er avh. av typen bærerakett.

*Eystein Sedberg:* Ein kan sikkert få profilar på bærerakettar frå ESA for å få vite termiske og mekaniske profilar.

*Jan:* Opprette kontakt med ESA og Norspace er viktig.

## **Arne Pedersen, UiO: Langmuirprobe**

***I ettertid har vi mottatt et proposal fra UIO angående dette forslaget til payload, dette finnes i vedlegg 5.***

Ein ynskjer å kartlegge strukturar i ionosfæra med ulik ladningstettleik. Desse strukturane påverkar propagasjon til radiobylgjer. Sjå vedlegg 5 for nærmare informasjon.

Instrumentet er laga av to stenger, prober, som til dømes kan stå ca 15 cm frå toppen av satellitten. Desse er forspent ulike spenningar og vil registrere ladning på grunn av elektronstrukturar satellitten går gjennom. Ein kan på den måten måle slike elektronstrukturar i størelsesorden meter. Ein treng å gjere ca 4000-5000 samples/sekund, kanskje i 16 bit oppløysing. Målingane treng ikkje vere kontinuerlege. Mest interessant ved pol-områdene? Kan danne eit bilete av nordlysovalen. Nytteverdien av målingane kan vere å danne seg eit bilde over område der slike elektron kan påvirke radiokommunikasjon slik som GPS og Galileo. Vektanslag er mellom 100 og 150 gram.

Treng truleg lite effekt, og begrensa med datakraft.

Satellitten må vere stabilisert; probene kan ikkje vere skjult bak strukturen, må ha fri-sikt i fartsretningen. Kan isolerast i stor grad frå resten av det mekaniske systemet.

## **Jan og Kjell Rohde, ITK: ADCS, Sensorar, Kalmanfilter og aktuatorar**

Sjå vedlagt presentasjon, vedlegg 6.

Det vert nytta ulike sensorar for å estimere orientasjonen til satellitten; magnetometer og sol-sensor. Har fått magnetometer og tilhøyrande software tilsent gratis. Komponentane har eit lågt straumforbruk.

Det skal brukast fotodioder for å finne kva retning av satellitten som peikar mot sola. Ein må ta høgde for Earth Albedo error, dvs. at sensoren ikkje må slå ut på reflektert solstråling frå jorda.

Har laga eit overslagsvis effektbudsjett, og ser ut til å bruke mindre enn tildelt. Det er bra; Effekt kan heller brukast på til dømes radioar.

Til estimering vert det brukt eit Extended Kalman filter som krevar mykje reknekraft. Nyttar Gauss-Newton algoritmen.

Vurderer å bruke ein låg-effekt mikrokontroller frå Texas.

Innspel frå Lasse Borja: Er PicoPower-serien til Atmel vurdert?

Gravitasjonsbom kan vise seg å vere nødvendig for å ha god stabilitet på satellitten utan å måtte regulere heile tida. Ynskjer å styre bommen med ein DC-motor. Då har ein moglegheit til å ha ei kontrollert ut- og inntrekking av gravitasjonsbom.

Magnetiske koiler (aktuatorar) av same storleik som brukt på nCube.

Spørsmål og innspel:

- Kan ein laste ned data frå estimatoren for å sjå korleis denne jobbar? Nyttig for rekonfigurering og seinare lærdom.
- Gravitasjonsbom og motor vert sett på som eit kompliserane element med fleire utfordringar som må vurderast.

## **Roger Birkeland, IET: VHF TTC-radio, Hardware**

Sjå vedlagd presentasjon, vedlegg 7

Spørsmål og innspel:

- Lasse Borja*: nCube hadde problem med reserverte ord som del av data. Bruke fleire bits ord? Vurdere å lage eit sjølstendig radiofyr på ein anna frekvens som er heilt autonomt og isolert frå resten av systemet.
- Håkon Indseth*: FSK gir det beste resultatet i smalband pga atmosfæriske effektar. Implementere moglegheit for tone-ranging for å måle avstand til satellitten. Utnytte bakkestasjoner verden rundt til overvåking og kommunikasjon med satellitten.
- Lasse Borja*: Ein får baneparameter frå NORAD.

## **Erik Narverud, IET: UHF nyttelastradio**

Sjå vedlagt presentasjon, vedlegg 8

Kommentarar:

- *Lasse Borja*: 300 kB for et semikomprimert VGA-bilde.
- *Håkon Indseth*: Sjekket fasegangen i filtrene?
- *Erik*: Ja, det er kontrollert og skal gå bra. Men må måle og verifisere på lab.

Målet er å ha ein opplink operativ heile tida.

## **Avsluttende ord**

Referat og presentasjonar skal sendast ut.

Kommentarar:

- *Odd Gutteberg*: Kunne tenke seg å køyre dette som eit “profesjonelt” prosjekt, men det er vanskeleg å gjennomføre skikkeleg pga. at studentane vert skifta ut etter som prosjektet går framover.
- *Erik* viste prosjektdatabasen, og sa litt om framtidige oppgåver og organisering. Ein treng omlag 10 studentar minimum frå hausten av for å ta tak i dei oppgåvene som ventar.

PR: Ønsker input.

- Interessant å vite om for radioamatører. Lag en hjemmeside med skikkelige faguttrykk.

Møtet slutt



# Small Student Satellite

*Elisabeth Karin Blom  
Erik Narverud  
Roger Birkeland  
Kjell Rohde  
Jan Rohde*

1

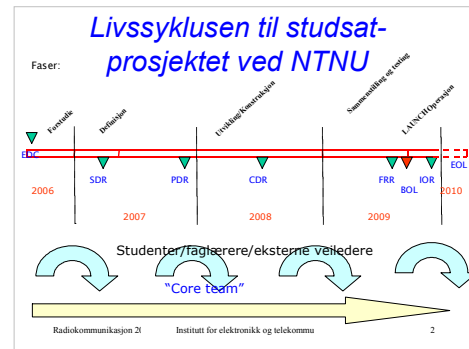

## Agenda

- 10.00 – 10.15 Introduksjon
- 10.20 – 12.00 Gjennomgang av spesifikasjon
  - Mechanical
  - Thermal
  - Power
  - Data (OBDH)
  - Payload (Kamera, Langmuirprobe)
- 12.00 – 12.30 Lunsj
- 12.30 – 14.00 Individuell gjennomgang av oppgaver
  - ADCS
  - Communication
- 14.00 – 14.30 Eventuelt (PR, rekruttering)

3

## Background

- A wish for a satellite developed by NTNU
- "Forstudie av liten Lavbanesatellitt"
- NAROM wants successor to NCUBE

4

## Project Management

- 4 launches in the period 2008-2011
- Co-operation between maximum 2 Norwegian institutions
- Every launch, one contest
- HiN was awarded launch in 2008

5

- Project spans over 2 years
- Currently involving IET, ITK, IDI
- Want to find participants from other fields
- Assignments as project and masters

6

ID	Task Name	Start	Finish	Duration	2006		2007		2008		2009		2010	
					01	02	03	04	05	06	07	08	09	10
1	Preliminary studies and planning	01.09.2006	28.12.2006	85d	■									
2	Application	31.10.2006	08.12.2006	29d	■									
3	Submit application	01.12.2006	01.12.2006	0d	◆									
4	Specification Review	15.12.2006	15.12.2006	0d	◆									
5	Structure and Radio System Construction	03.01.2007	26.07.2007	167d	■									
6	Preliminary Design Review	01.06.2007	01.06.2007	0d	◆									
7	Design of Subsystem Engineering Models	30.06.2007	01.04.2008	154d	■									
8	Preliminary System Function Test	03.03.2008	03.03.2008	0d	◆									
9	Critical Design Review	01.04.2008	01.04.2008	0d	◆									
10	Flight Model Subsystem Design and Production	01.04.2008	01.06.2008	89d	■									
11	Flight Model Assembly and Testing	01.06.2008	22.06.2009	232d	■									
12	System Function Test	31.12.2008	31.12.2008	0d	◆									
13	Launch preparations and launch	09.02.2009	27.07.2009	121d	■									
14	In-Orbit Operations	28.07.2009	24.03.2010	172d	■									
15	Review	08.09.2009	20.04.2010	161d	■									

ID	Task Name	Start	Finish	Duration	2006		2007		2008		2009		2010	
					01	02	03	04	05	06	07	08	09	10
1	Preliminary studies and planning	01.09.2006	28.12.2006	85d	■									
2	Application	31.10.2006	08.12.2006	29d	■									
3	Submit application	01.12.2006	01.12.2006	0d	◆									
4	Specification Review	15.12.2006	15.12.2006	0d	◆									
5	Structure and Radio System Construction	03.01.2007	26.07.2007	147d	■									
6	Preliminary Design Review	01.06.2007	01.06.2007	0d	◆									
7	Design of Subsystem Engineering Models	30.06.2007	01.04.2008	154d	■									
8	Preliminary System Function Test	03.03.2008	03.03.2008	0d	◆									
9	Critical Design Review	01.04.2008	01.04.2008	0d	◆									
10	Flight Model Subsystem Design and Production	01.04.2008	01.06.2008	89d	■									
11	Flight Model Assembly and Testing	01.06.2008	22.06.2009	232d	■									
12	System Function Test	31.12.2008	31.12.2008	0d	◆									
13	Launch preparations and launch	09.02.2009	27.07.2009	121d	■									
14	In-Orbit Operations	28.07.2009	24.03.2010	172d	■									
15	Review	08.09.2009	20.04.2010	161d	■									

## Specification Overview

- CubeSat standard
- 2 litre, 2 kg
- 145 MHz (TT&C) and 437 MHz (payload) transceivers
- Stabilized with magnetic coils
- Platform based concept able to carry a multitude of payloads

9

## Mission Goals

- Deliver a fully functional and tested satellite for launch
- Transmit a beacon signal receivable for radio amateurs
- Establish two-way communication
- Testing attitude control, consisting of magnetic coils
- Capture an image
- Take a picture of Earth
- Transmit the image to the ground

10

## Assignments

- Most work to be done as 9<sup>th</sup> semester project and masters theses
- This enables students to be engaged in the project during two consecutive semesters
- Tasks include:
  - Design
  - Simulation
  - Construction
  - Test

11

## Why?

- Multidisciplinary project to every extent!
- PR for education at NTNU
- Use theories in practice!
- A more tidy project than NCUBE. Locally managed
- Ambitious project...
- ...and FUN!

12

More Information:

<http://org.ntnu.no/studsat>  
[studsat@list.stud.ntnu.no](mailto:studsat@list.stud.ntnu.no)



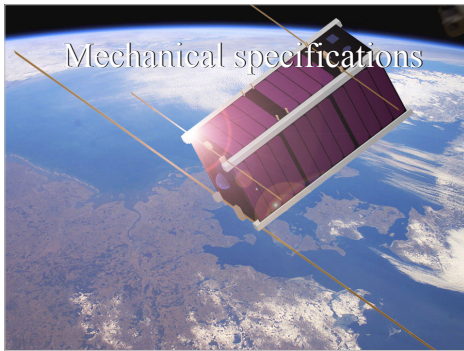

### The CubeSat standard

- Developed by California Polytech. Institute
- A universal standard for small "piggy-back"-launched satellites.
- Designed to minimize complications and interference with the carrying vessel.
- Specifies:
  - Dimensions
  - Weight and mass center
  - Initial Operation and Communication restrictions

2

### The CubeSat standard

- Up to 3 satellites are contained in a "P-POD", and simultaneously ejected by a tensioned spring.
- 1, 2 and 3 liter platform sizes available
- 6,5 mm of space available for external components on all sidewalls
- The rails are the only parts allowed in contact with the P-POD at any time

3

### The Poly-Picosat Orbital Deployer (P-POD)

4

### 2 Liter CubeSat:

- 10x10x227 cm, 2 kg
- Advantages to a 1 liter cube:
  - Larger surface means more power
  - Easier to integrate antenna systems
  - Easy adaptation to different missions.
  - Can handle larger and more power intensive payloads, thus more versatile.
- Downsides:
  - More expensive to launch than a single cube
  - Fewer available launches

5

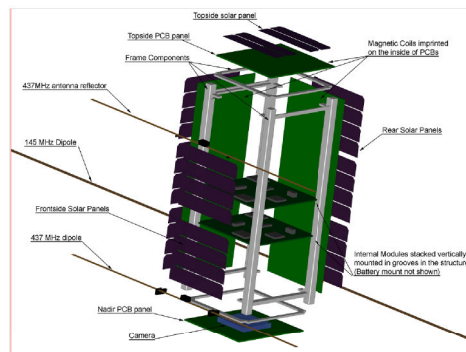

## Preliminary Mass budget

Component	Type	Preliminary Dimensions	Quantity	Unit weight	Maximum allowed weight	Total weight
Chassis	7074 Aluminum	100x100x227	1	300	300	300
Sidewalls	FR4 PCB	100x83x1.55	4	40	160	160
Nadir wall	FR4 PCB	100x100x1.55	1	30	30	30
Zenith wall	FR4 PCB	100x100x1.55	1	30	30	30
Solar cells	Si Cells, mounted on sidewalls	80x160x0.5	80	1.2	70	70
Batteries	Lithium 2000 mAh	TBD	2	100	200	200
Battery mounts	7074 Aluminum	TBD	1	50	50	50
Magnetic coils	Printed on sidewall PCB's	TBD	3	0	0	0
437MHz transmitter	PCA	80x80x15	1	50	50	50
149MHz transceiver	PCA	80x80x15	1	50	50	50
ADCS	PCA and sensors	80x80x15	1	80	80	80
OSDH system	PCA and sensors	80x80x15	1	70	70	70
Power management system	PCA and sensors	80x80x15	1	60	60	60
Camera payload	PCA	80x80x15	1	40	40	40
Antenna release system	PCA and mechanics	TBD	1	60	60	60
437 MHz antenna	Antenna and mounting	330x4x1	1	5	5	5
437 MHz reflector	Reflector and mounting	340x4x1	1	5	5	5
149 MHz antenna	Antenna and mounting	1500x8x1	1	20	20	20
Flight Pin	TBD	TBD	1	10	10	10
Connector	TBD	TBD	1	10	10	10
Kill switch	TBD	TBD	2	4	10	10
Misc. Connecting hardware	TBD	TBD	1	100	100	100
<b>SUM</b>						<b>1410</b>

## Mechanical Challenges

- Chassis demands:
  - conformity with the CubeSat standard
  - as light as possible
  - Must endure launch and space environment
  - Must not be susceptible to harmonic vibration during launch

8

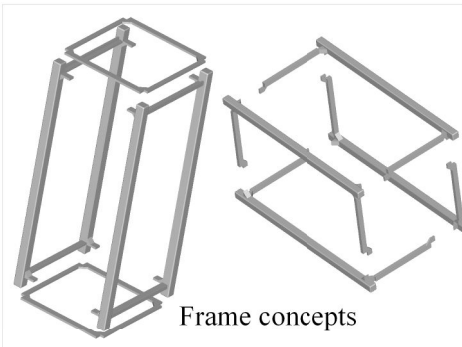

## Antenna challenges

- The antenna must be stowable
- The mechanism must endure launch and space environment
- Mounting solution must not conflict with other parts, such as solar panels.
- The materials used must be able to withstand space conditions.

10

## Antenna Deployment Mechanism

- A successful antenna deployment is essential for satellite operation
- The mechanical aspect makes antenna deployment a critical factor
- A possible solution makes use of leafspring antenna elements, held down by nylon threads
- The nylons are melted by NiChrome wires, releasing the elements

11

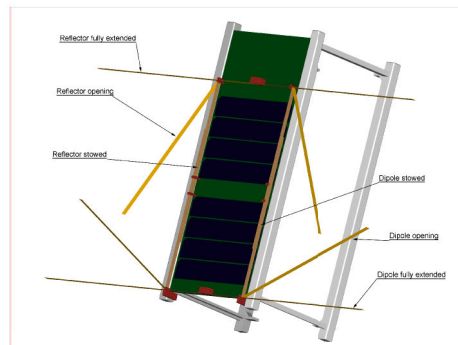

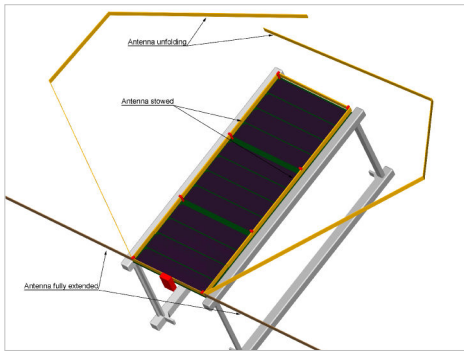

More information:

- <http://org.ntnu.no/studsat>
- [Studsat@list.stud.ntnu.no](mailto:Studsat@list.stud.ntnu.no)

 **NTNU**  
Innovation and Creativity

14

The slide features a background image of a satellite in orbit above Earth. The satellite is a small, rectangular object with a purple and white color scheme. The text and logo are overlaid on the bottom left of the image.



### Thermal Environment

- Electronic components must operate within the whole temperature range
- The structure must not be deformed
- Only passive regulation
- Thermal equilibrium depends on material constants  $\alpha$  and  $\epsilon$
- Estimate: 290 K (about 17 C) with 2 to 5 W internal heat production. (Amplifiers and so on)

2

### Thermal Environment

- Big differences in temperature
- Electronic components must operate within the temperature range
- Only passive regulating
- The structure must not be deformed by thermal expansion

3

### Eclipse

- Eclipse lasts for about 40 minutes
- As cold as -25 C
- Some components may require special consideration

4

### Heat Sources

- Estimate, possible peak power dissipation
- TT&C radio: 1 W dissipated heat
- Payload radio: 1 W
- DC/DC loss in power system: 2 W (80%)
- Miscellaneous: 0.5 W
- Total 4.5 W maximum

5

### Example

- 4 W internal heat source
- 40 minutes in eclipse
- Equilibrium: 290 K

Time in Eclipse (min)	Temperature (C)
0	17
10	10
20	3
30	-4
40	-11

6

## Future Work

- A simple thermal analysis has been conducted, but more knowledge of the satellites thermal environment is desirable
- A full analysis of the structure would be useful in order to detect possible temperature related problems before launch.
- Coating, thermal properties of the solar cells and heat conduction from amplifiers.
- Temperature at battery bank





## Power Management

- Monitor charging
- Monitor power usage
- Predict power usage
  - Decide if a scheduled operation can proceed
  - Based on battery capacity
  - Illuminated solar panels

2

## Power Management

- In case of insufficient power
  - Prioritise according to the following list
  - Charging
  - ADCS
  - OBDDH
  - Service Transmission
  - Payload
  - Payload Transmission

3

Expected submodule power consumptions	Worst case	Best case	Expected	Allocated	Unit	Comment
<b>APX/ATC transmitter</b>						
operational time per orbit	6000	3000	3000	3600	sec	
emitted power	2	1	1.5	1.5	W	
efficiency	0.4	0.6	0.5	0.5		
power consumption	5	1.67	3	3	W	
<b>energy consumption</b>	<b>30000</b>	<b>9000</b>	<b>15000</b>	<b>13500</b>	Wh/orbit	With 1 transmission each orbit
<b>ATC Receiver (electromagnetic)</b>						
operational time per orbit	6000	6000	6000	6000	sec	
power consumption	0.3	0.1	0.2	0.25	W	
<b>energy consumption</b>	<b>1800</b>	<b>600</b>	<b>1200</b>	<b>1350</b>	Wh/orbit	
<b>Beacon</b>						
operational time per orbit	400	200	300	360	sec	
emitted power	1	0.6	0.8	0.8	W	
efficiency	0.4	0.6	0.5	0.5		
power consumption	2.5	1.6	1.6	1.6	W	
<b>energy consumption</b>	<b>1000</b>	<b>200</b>	<b>480</b>	<b>648</b>	Wh/orbit	
<b>TTAC transmitter</b>						
operational time per orbit	600	300	300	360	sec	
emitted power	4	1.5	1.5	1.5	W	
efficiency	0.4	0.6	0.5	0.5		
Power consumption	10	1.67	3	3	W	
<b>energy consumption</b>	<b>3600</b>	<b>900</b>	<b>1800</b>	<b>1350</b>	Wh/orbit	With 1 transmission each orbit
<b>TTAC receiver</b>						
operational time per orbit	6000	6000	6000	6000	sec	equal to orbit time
power consumption	0.3	0.1	0.15	0.15	W	
<b>energy consumption</b>	<b>1800</b>	<b>600</b>	<b>900</b>	<b>900</b>	Wh/orbit	
<b>Camera</b>						
power consumption per image	0.2	0.2	0.2	0.2	W	
operational time per orbit	5	1	4.5	6	sec	
<b>energy consumption</b>	<b>1</b>	<b>0.2</b>	<b>0.9</b>	<b>1.2</b>	Wh/orbit	1 picture taken each orbit
<b>ADCS system (standby)</b>						
MCU power consumption	0.5	0.1	0.25	0.25	W	
sensor power consumption	0.1	0.02	0.05	0.05	W	Depending on number and type of sensors
<b>total power consumption</b>	<b>0.6</b>	<b>0.12</b>	<b>0.3</b>	<b>0.3</b>	W	Without attitude corrections

operational time per orbit	6000	6000	6000	3600	Unit	Comment
<b>energy consumption</b>	<b>2400</b>	<b>1200</b>	<b>1800</b>	<b>2025</b>	Wh/orbit	Without attitude corrections
<b>Power management system</b>						
MCU power consumption	0.5	0.1	0.2	0.25	W	
sensor power consumption	0.05	0.01	0.02	0.025	W	Depending on number and type of sensors
<b>total power consumption</b>	<b>0.55</b>	<b>0.11</b>	<b>0.22</b>	<b>0.275</b>	W	
operational time per orbit	6000	6000	6000	3600	sec	
<b>energy consumption</b>	<b>3300</b>	<b>660</b>	<b>1260</b>	<b>1350</b>	Wh/orbit	
<b>OBDDH system</b>						
MCU power consumption	0.3	0.2	0.25	0.25	W	Including data storage unit
sensor power consumption	0.3	0.05	0.05	0.05	W	Including temperature sensors for entire sat
<b>Total power consumption</b>	<b>0.6</b>	<b>0.25</b>	<b>0.3</b>	<b>0.3</b>	W	
operational time per orbit	6000	6000	6000	3600	sec	
<b>energy consumption</b>	<b>3600</b>	<b>1800</b>	<b>3000</b>	<b>3000</b>	Wh/orbit	

5

Energy and Power budget based on 100 minute orbit 6000 seconds					
Subsystem	(W, maximum)	(W, average)	energy (Wh/orbit)	Unit	Comment
<b>Allocated energy consumption per orbit</b>					
ADCS system with sensors and data storage	0.6	0.3	3600	Wh/orbit	
TTAC transmitter	1	0.22	1300	Wh/orbit	
TTAC receiver	0.2	0.2	1200	Wh/orbit	
ATNA to transmitter	3	0.22	1300	Wh/orbit	
ATNA to receiver	1	0.2	1200	Wh/orbit	Not used, usually deactivated
145 MHz beacon	2	0.1	600	Wh/orbit	
ADCS system (standby) with sensors	0.3	0.2	2000	Wh/orbit	
Power management system with sensors	0.3	0.25	1500	Wh/orbit	Charge power not included
Camera	0.2	0.05	300	Wh/orbit	
<b>Total power consumption</b>	<b>16.2</b>	<b>2.12</b>	<b>12150</b>	Wh/orbit	
<b>Total energy consumption per orbit</b>					
<b>energy production parameters</b>	<b>Worst case</b>	<b>Best case</b>	<b>Expected</b>	<b>Unit</b>	<b>Comment</b>
Total solar cell area	0.08	0.07	0.075	m <sup>2</sup>	Depending on cell area
Solar radiation power in LEO	1016	1353	1033	W/m <sup>2</sup>	Depending on cell type
Cell efficiency	0.15	0.2	0.18		Depending on cell type
Load cut time	11.2	0.3	0.28	h	Depending on sat angle
<b>produced power</b>	<b>3.26</b>	<b>7.54</b>	<b>4.60</b>	W	
Round-trip loss	0.5	0.5	0.5	W	Depending on sat parameters
Cost time	6000	6000	6000	sec	Depending on orbit altitude
<b>produced energy</b>	<b>19512</b>	<b>45240</b>	<b>27600</b>	Wh/orbit	
<b>Energy available for attitude control and payload</b>					
Energy storage parameters	Worst case	Best case	Expected	Unit	Comment
Battery capacity	3	2	2.5	2Ah	Depending on battery type
Main battery voltage	7.2	7.2	7.2	V	Depending on main battery V
Energy storage capacity	21600	14400	18000	J	
Energy taken from storage per orbit	484	282	484	J	
Available charging time	3000	4800	3000	sec	
<b>Needed charge power</b>	<b>1.6</b>	<b>0.6</b>	<b>1.6</b>	W	
<b>Discharge percentage</b>	<b>18.6%</b>	<b>0.64%</b>	<b>6.54%</b>		Should not exceed 30%

6

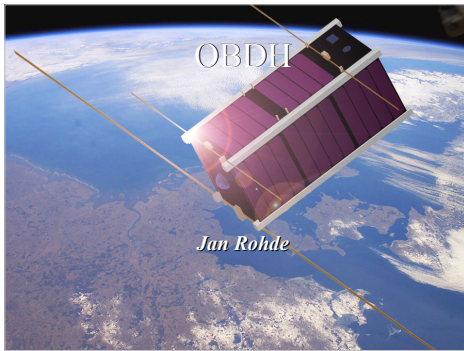

## OBDR

- On-board communication
  - Distributed solution
  - I/C
  - Redundancy
- Flight computer
  - Master
  - Shut-down of malfunctioning components
  - Software reload capability?
- Memory
  - Radiation resistant



## Attitude determination

- Two independent sensor systems
  - Earth magnetic field sensor
  - Sun sensor
- Kalman filter

2

## Earth magnetic field sensor

- Digital Magnetometer
- IGRF
  - Stored locally
- Disturbances
  - switching

3

## Sun sensor

- Photodiodes
  - Light-to-frequency
- Earth Albedo error

4

## Attitude determination

- Two independent sensor systems
  - Earth magnetic field sensor
  - Sun sensor
- Kalman filter

5

## Kalman Filter

- Extended Kalman Filter
- Gauss-Newton Algorithm
- Implementation

6

## Controller and actuators

- Inertia Matrix
  - Antenna placements
  - Gravity boom
- Actuators
  - Magnetic coils
  - Constant or variable current actuation
  - Resonant frequencies

7

## Controller and actuators

- Controller
  - Modes
    - De-tumbling
    - Positioning
    - Attitude control
  - Operation
    - Switching between actuation and measurement

8

## Controller and actuator

- Energy considerations when detumbling
  - Max coil requirements are 9622J/Orbit
  - Controller requirement 108J/Orbit

Energy production parameters	Worst case	Best case	Expected	Unit
Total solar cell area	0.01	0.01	0.01	m <sup>2</sup>
Solar radiation power in LEO	0.110	0.363	0.363	W/m <sup>2</sup>
Cell efficiency	0.15	0.28	0.2	
Maxed cell area	0.25	0.3	0.25	
produced power	2.46	7.64	4.46W	
Illuminated orbit	0.01	0.01	0.01	sec
Cycle time	6000	6000	6000	sec
Acquired energy	10 811	36 660	16 074	J/Orbit

9



## TT&C Radio System

- 145 MHz VHF band
- 25 kHz available bandwidth
- 9600 bit/s
- Omnidirectional antenna
- Main control link

2

## Basic Features

- Low power
- Must work
- As much as possible should be done in HW
  - Software is prone to bit-flips and can malfunction
  - But software can be reloaded

3

## Design

- Three possibilities
  - Integrated transceiver system, such as the ADF7020-1 with a PA and LNA --> easy
  - Simple system with a VCO as modulator and PLL as de-modulator --> simple, but much SW
  - A system with a integrated modem and integrated subsystems

4

## Design

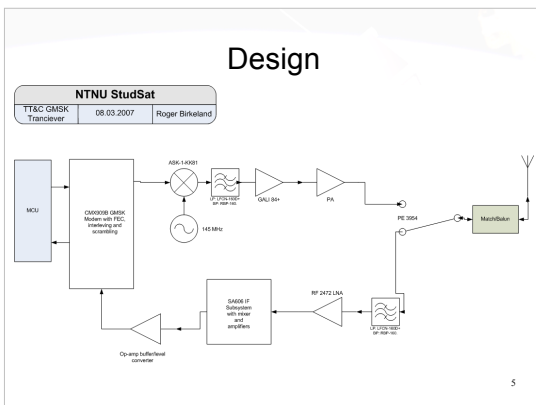

5

## Transmitter

- The GMSK-modem can implement FEC, interleaving and scrambling
- Challenges, components not decided yet
  - Power Amplifier (RF5110G must be tested)
  - Output switch (PE3954 or HSWA2-30DR)
  - Matching/balun needed for antenna?
  - Local Oscillator. Can we get a custom frequency?

6

## Receiver

- Received signal level about -90 to -70 dBm
- Only one LNA stage is needed
- NXP SA606 integrated IF subsystem takes care of direct down conversion (must be tested and verified)
- Signal from SA606 must be buffered through an op-amp before the GMSK-modem

7

## Receiver, Challenges

- Local oscillator
- The SA606 has high gain, and high dynamic range, must be tested. No need for a AGC?
- Verify that direct conversion is possible.

8

## Design Summary

- Started the design process from scratch
- Decided modulation method (FSK/GMSK)
- Looked for components
- Many components --> high current consumption
- Found the SA606
- Checked nCUBE-design --> they used this as well

9

## Digital Signal Processing

- The GMSK-modem covers most needed functions.
- The MCU delivers a synchronous data signal to the modem at TX. The modem will provide a synchronous signal to the MCU when in RX
  - Timing and bit recovery
  - Option: FEC
  - Option: Interleaving
  - Option: Scrambling
- Data to/from the radio goes via an I2C-bus to the MCU.

10

## Antenna

- Dipole
- Omnidirectional
- About 20 MHz bandwidth
- Measurement showed resonance at UHF-band, need a LP filter on RX-side
- Matching/balun
  - Single-ended --> balanced signal

11

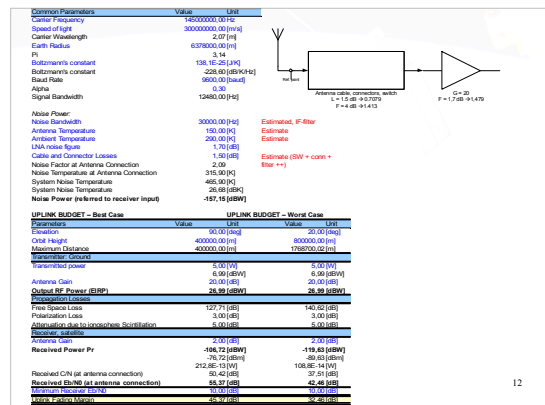

12

## Link Budget - Uplink

- Transmit; 5 W, 20 dB antenna gain
- Received signal level
  - 400 km; 90 deg. Elevation: -76.7 dBm
    - C/N = 50.4 dB
    - Fading margin: 45.4 dB
    - $E_b/N_0 = 50.4 + 10 \log(30000/9600) = 55.4$  dB
  - 800 km; 20 deg. Elevation: -89.6 dBm
    - C/N = 37.5 dB
    - Fading margin: 32.7 dB
    - $E_b/N_0 = 37.5 + 4.9 = 42.5$  dB

13

UPPERLINK Parameters	Value	Unit
Carrier Frequency	14000000.0000	[Hz]
Speed of light	300000000.0000	[m/s]
Carrier Wavelength	2.07	[m]
Earth Radius	6378000.0000	[m]
PI	3.14	
Bottomarm's constant	138.4525	[K]
Bottomarm's constant	-28.60	[dB/K <sup>2</sup> ]
Bandwidth	9600.0000	[Hz]
Alpha	0.30	
Signal Bandwidth	12480.0000	[Hz]
Noise Power		
Noise Bandwidth	3000.0000	[Hz]
Antenna Temperature	290.0000	[K]
Ambient Temperature	290.0000	[K]
Link noise figure	1.70	[dB]
Cable and Connector Losses	1.50	[dB]
Noise Factor at Antenna Connection	2.00	
Noise Temperature at Antenna Connection	315.0000	[K]
System Noise Temperature	605.0000	[K]
System Noise Temperature	27.62	[dBK]
Noise Power (referred to receiver input)	-156.09	[dBW]

DOWNLINK BUDGET - Best Case	Value	Unit	DOWNLINK BUDGET - Worst Case	Value	Unit
Frequency	14000000.0000	[Hz]	Frequency	14000000.0000	[Hz]
Elevation	90.0000	[deg]	Elevation	20.0000	[deg]
Cable Height	400000.0000	[m]	Cable Height	800000.0000	[m]
Maximum Distance	400000.0000	[m]	Maximum Distance	1788700.0000	[m]
Transmitted Power	1.0000	[W]	Transmitted Power	1.0000	[W]
Antenna Gain	0.0000	[dB]	Antenna Gain	2.0000	[dB]
Output RF Power (ERP)	2.0000	[dBW]	Output RF Power (ERP)	2.0000	[dBW]
Propagation Losses			Propagation Losses		
Free Space Loss	127.71	[dB]	Free Space Loss	143.00	[dB]
Polarization Loss	3.00	[dB]	Polarization Loss	3.00	[dB]
Attenuation due to Ionosphere Scintillation	0.00	[dB]	Attenuation due to Ionosphere Scintillation	0.00	[dB]
Receiver Gains			Receiver Gains		
Receiver Antenna Gain (before antenna)	45.00	[dB]	Receiver Antenna Gain (before antenna)	20.00	[dB]
Received Power (before antenna)	-113.71	[dBW]	Received Power (before antenna)	-128.02	[dBW]
Received Power (at antenna connection)	61.71	[dBW]	Received Power (at antenna connection)	46.00	[dBW]
Received SNR (at antenna connection)	45.66	[dB]	Received SNR (at antenna connection)	217.70	[dB]
Received SNR (at antenna connection)	42.29	[dB]	Received SNR (at antenna connection)	20.38	[dB]
Received SNR (at antenna connection)	41.24	[dB]	Received SNR (at antenna connection)	34.33	[dB]
Received SNR (at antenna connection)	37.50	[dB]	Received SNR (at antenna connection)	30.00	[dB]
Received SNR (at antenna connection)	37.24	[dB]	Received SNR (at antenna connection)	24.33	[dB]

14

## Link Budget - Downlink

- Transmit; 1 W, 2 dB antenna gain
- Received signal level
  - 400 km; 90 deg. elevation: -83.7 dBm
    - C/N = 42.3 dB
    - Fading margin: 37.2 dB
    - $E_b/N_0 = 42.3 + 4.95 = 47.2$  dB
  - 800 km; 20 deg. elevation: -96.6 dBm
    - C/N = 29.4 dB
    - Fading margin: 24.3 dB
    - $E_b/N_0 = 29.4 + 4.95 = 34.3$  dB

15

## Challenges

- Must look into ionosphere effects
- Transmit power: 1 W or 0.5 W, good margins
- Other considerations (Future tasks)
  - Antenna mounting and deployment
  - Beacon
  - Develop own PA?

16





### Known parameters

- Assumed Carrier frequency 437.305 MHz
- Assumed allowed bandwidth 25 KHz
- +/- 12 KHz Doppler
- Half-duplex transceiver
- Primary function is payload data transmitter
- Limited power available
- directive dipole antenna concept developed

### Initial Link Budget

Constants	Worst Case	Best Case	Unit
Carrier Frequency	4,37E+08	4,37E+08	[Hz]
Speed of light	3,00E+08	3,00E+08	[m/s]
Carrier Wavelength	0,69	0,69	[m]
Earth Radius	6378000,00	6378000,00	[m]
Pi	3,14	3,14	
Boltzmann's constant	1,38E-23	1,38E-23	[J/K]
Parameters	Value	Value	Unit
elevation	10,00	90,00	[deg]
Orbit Height	800000,00	400000,00	[m]
Maximum Distance	2366866,61	400000,00	[m]
Output RF Power (EIRP)	0,00	0,00	[dBW]
Propagation Losses			
Free Space Loss	152,74	137,30	[dB]
Polarization Loss	3,00	3,00	[dB]
atmospheric scintillation	6,00	3,00	[dB]
Satellite antenna gain	2,00	5,77	[dB]
Power at antenna connection	-159,74	-137,53	[dBW]
<b>Difference in received power</b>	<b>22,21</b>		<b>[dB]</b>
Noise properties for satellite antenna			
antenna Noise bandwidth	3,50E+04	3,50E+04	[Hz]
antenna noise temperature	300,00	200,00	[K]
noise power on antenna connection	-158,39	-160,15	[dB]
<b>C/N at antenna connection</b>	<b>-1,35</b>	<b>22,62</b>	<b>[dB]</b>

### Demands

- Relatively high baud rate, enabling image download during a single transmission
- High reliability
- Low power consumption
- Low complexity
- Protocol/packet handling and coding capability

### Desired features:

- Modulation with good spectral efficiency and low linearity requirements, due to the narrow band and low output power
- Highly integrated "Off-the-Shelf" components for higher reliability and low power consumption
- Good noise performance
- As many Hardwired parameters as possible

### Alternative 1: fully integrated system

- Based on short range transceivers such as Nordic or Chipcon/TI products
- Advantages:
  - Very few parts
  - Low power consumption
- Disadvantages:
  - Design constrained by few degrees of freedom
  - Poor noise performance
  - Software defined – vulnerable to SEU/latch-up



## Fully integrated system layout

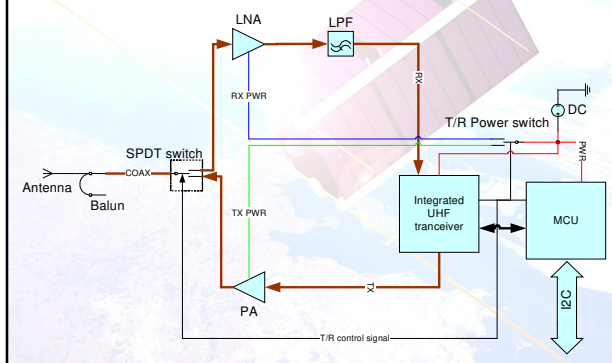

## Alternative 2: Component assembled system with DSP

- Based on off-the-shelf components designated for hand-held systems and base-stations, with a designated DSP
- Advantages:
  - Enables custom design and modulation
  - Good Noise performance
- Disadvantages:
  - High power consumption due to DSP
  - High complexity
  - Software defined modem vulnerable to SEUs/latch-up

## DSP system layout

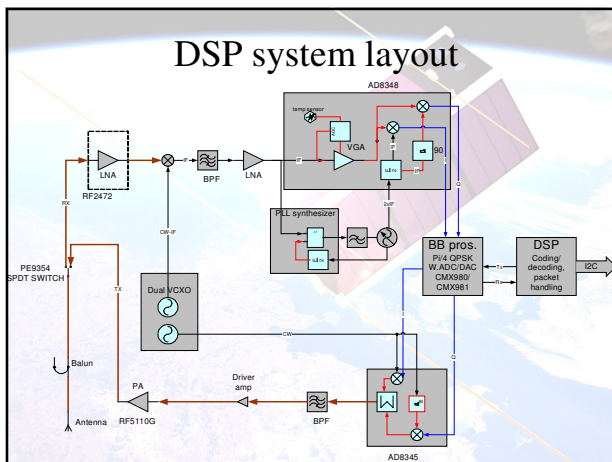

## Alternative 3: Integrated system without DSP

- How to get rid of the power consuming DSP?
  - PI/4-DQPSK modulator available; DSP needed only for demod
  - No need for high-speed uplink
  - No need for QPSK modulated uplink
  - Half-duplex, RX powered down when transmitting and vice versa, enables use of two baseband processors
- Decision made to use GMSK modulation uplink
  - DSP replaced with PI/4-DQPSK modulator and GMSK demodulator(modem), both available off-the-shelf.

## Key features:

- Transmitter:
  - 19,2 KBPS raised cosine pi/4-DQPSK modulation
  - Coding, packet handling and FEC
  - Potentially 1.5 W output power
  - Potentially 50% DC efficiency
- Receiver:
  - Double superhet 9600 BPS GMSK
  - Decoding, Packet handling and FEC
  - IF system similar to VHF receiver

## Final system Layout

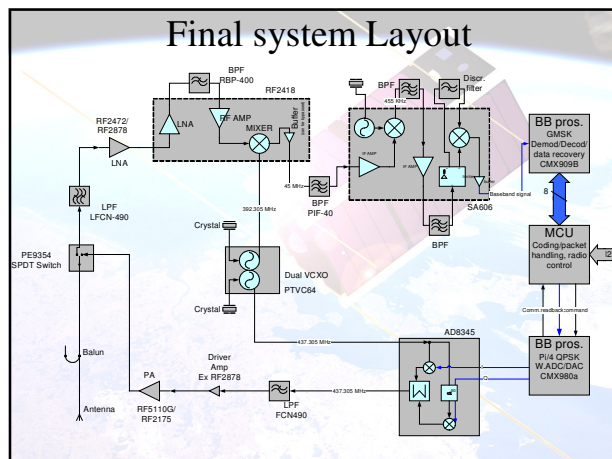

## Power consumption

Transmitter	Voltage	Current, mA		Power mW	
		transmit	standby	transmit	standby
MCU	3	10	0	30	0
CMX80A baseband processor	3	20	0	60	0
ADB345 modulator/converter	3	65	0,07	195	0,21
VXCO	3	40	0	120	0
PA driver amp	3	20	0	60	0
Power amp with 50% DC efficiency	3	900	0,01	2700	0
PE9354 SPDT switch	3	0,02	0	0,06	0
<b>Receiver</b>		<b>standby</b>	<b>receive</b>	<b>standby</b>	<b>receive</b>
MCU	3	0	10	0	30
CMX909 modem	3	0	2,5	0	7,5
SA606	3	0	4	0	12
VXCO	3	0	40	0	120
RF2418 LNA/mixer	3	0	12	0	36
RF2472 LNA	3	0	6	0	18
PE9354 SPDT switch	3	0	0,02	0	0,06
<b>TOTALS:</b>	<b>DC/DC eff</b>	<b>Transmit</b>	<b>receive</b>	<b>Transmit</b>	<b>receive</b>
	90 %	1172,244	82,88889	3516,733	246,6333

## Downlink budget

Constants	Worst Case	Best Case	Unit
Carrier Frequency	4,37E+08	4,37E+08	[Hz]
Speed of light	3,00E+08	3,00E+08	[m/s]
Carrier Wavelength	0,69	0,69	[m]
Earth Radius	6378000,00	6378000,00	[m]
Pi	3,14	3,14	
Boltzmann's constant	1,38E-23	1,38E-23	[J/K]
<b>Parameters</b>	<b>Value</b>	<b>Value</b>	<b>Unit</b>
elevation	10,00	90,00	[deg]
Orbit Height	800000,00	800000,00	[m]
Maximum Distance	2366866,61	800000,00	[m]
<b>Propagation Losses</b>			
Free Space Loss	152,74	143,32	[dB]
Polarization Loss	3,00	3,00	[dB]
Atmospheric scintillation	6,00	3,00	[dB]
<b>Total Path Loss</b>	<b>161,74</b>	<b>149,32</b>	<b>[dBW]</b>
<b>Noise properties for Ground Station</b>			
Receiver antenna gain	10,00	30,00	[dBW]
Noise bandwidth	3,59E+04	3,59E+04	[Hz]
antenna noise temperature	300,00	250,00	[K]
Receiver noise temperature	450,00	300,00	[K]
<b>System Noise power</b>	<b>-154,71</b>	<b>-157,73</b>	<b>[dB]</b>
<b>Satellite Transmitter Properties</b>			
Antenna SMA connector loss	-0,08	-0,08	[dB]
coax cable loss	-0,20	-0,20	[dB]
PCB SMA connector loss	-0,08	-0,08	[dB]
PE9354 switch loss	-0,50	-0,40	[dB]
PA output power	1,00	2,00	[dBW]
Emitted power	0,14	1,40	[dBW]
Satellite antenna gain	2,00	5,77	[dB]
<b>dB</b>	<b>2,14</b>	<b>7,17</b>	<b>[dB]</b>
<b>TOTALS</b>			
<b>Received Power</b>	<b>-149,60</b>	<b>-122,16</b>	<b>[dB]</b>
<b>Estimated SNR</b>	<b>5,11</b>	<b>33,61</b>	<b>[dB]</b>

## Receiver Gain/noise performance

Component	name	Gain[dB]	NF[dB]	Noise temp[K]	Cascade	
					Gain[dB]	Noise temp[K]
Antenna connection	SMA	-0,06	0,06	4,034301864	-0,06	4,034301864
coax cable	0,25 m	-0,1	0,1	6,754967761	-0,16	10,88324059
connection	SMA	-0,06	0,06	4,034301864	-0,22	15,06894341
switch	PE9354	-0,4	0,4	27,97867688	-0,62	44,5014477
Filter	FCN490	-0,75	0,75	54,66564596	-1,37	107,5557122
LNA	RF2472	20	1,5	119,6358879	18,63	271,5623695
2 LNA	RF2418	14	1,8	148,932762	32,63	273,6040616
Filter	RBP_400	-1,5	1,5	119,6358879	31,13	273,6693538
RF-amp/mixer	RF2418	6	10	2510	37,13	275,8814119
Filter	PIF-40	-0,4	0,4	27,97867688	36,73	275,6862298
2. Mixer stage	SA606	17	6,2	918,9212121	53,73	275,8819392
Filter	CFUKF455KA2X	-4	4	438,4470651	49,73	275,8837966

## Uplink Budget

Constants	Worst Case	Best Case	Unit
Carrier Frequency	4,37E+08	4,37E+08	[Hz]
Speed of light	3,00E+08	3,00E+08	[m/s]
Carrier Wavelength	0,69	0,69	[m]
Earth Radius	6378000,00	6378000,00	[m]
Pi	3,14	3,14	
Boltzmann's constant	1,38E-23	1,38E-23	[J/K]
Physical Temperature	290,00	290,00	[K]
<b>Parameters</b>	<b>Value</b>	<b>Value</b>	<b>Unit</b>
elevation	10,00	90,00	[deg]
Orbit Height	800000,00	800000,00	[m]
Maximum Distance	2366866,61	800000,00	[m]
<b>Reference EIRP</b>	<b>0,00</b>	<b>0,00</b>	<b>[dB]</b>
<b>Propagation Losses</b>			
Free Space Loss	152,74	143,32	[dB]
Polarization Loss	3,00	3,00	[dB]
atmospheric scintillation	6,00	3,00	[dB]
Satellite antenna gain	2,00	5,77	[dB]
<b>Power at antenna connection</b>	<b>-158,74</b>	<b>-143,32</b>	<b>[dBW]</b>
<b>Noise properties for satellite antenna</b>			
System Noise bandwidth	3,59E+04	3,59E+04	[Hz]
brightness noise temperature	300,00	250,00	[K]
antenna efficiency	1,00	1,00	
Noise on Antenna connection	298,00	250,00	[K]
<b>SNR at Antenna connection</b>	<b>-1,22</b>	<b>15,03</b>	
<b>Satellite receiver properties</b>			
Receiver noise temperature	275,88	275,88	[K]
Receiver Gain	49,73	49,73	[dB]
Sensitivity on 2nd Stage IF input	-107,00	-112,00	[dB]
Required SNR on 2nd stage IF input	17,00	12,00	[dB]
<b>TOTALS</b>			
Noise temperature (ret. Ant. Connection)	575,98	525,88	[K]
Total power on 2nd. IF stage input	-110,98	-93,82	[dBW]
SNR on 2nd stage IF input	-4,19	12,40	[dB]
<b>MARGINS</b>			
Sensitivity margin	-3,98	18,18	[dB]
SNR margin	-21,19	0,40	[dB]

## UHF Antenna System

- Request for a directive antenna in order to increase data throughput
- Potentially inaccurate attitude control requires wide main lobe.
- GOAL: Design a wide, uniform main lobe with a minimum of backwards radiation, realizable as a robust, simple antenna.
- Designed as a dipole with a passive reflector**

## Key features

- Maximum gain of 5.77 dB
- 151x76 degree 3dB lobe width
- 32 MHz effective bandwidth
- Perfect impedance match of 50 Ohms** (simulated VSWR<1.01)
- Higher gain than a regular dipole for scan angles up to 125 degrees
- Usable as an omnidirectional antenna if the reflector is kept folded.** (VSWR=1.8)

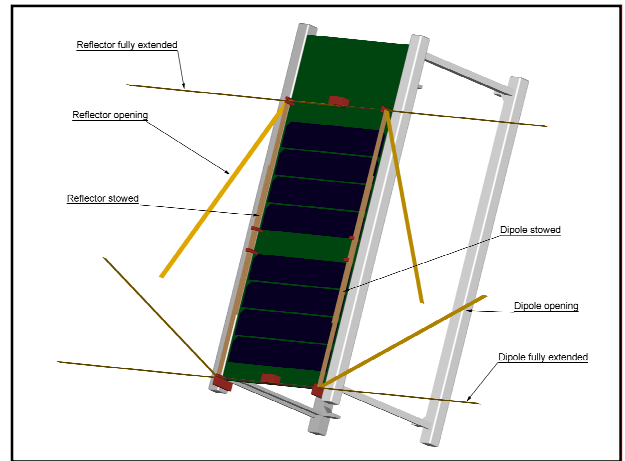
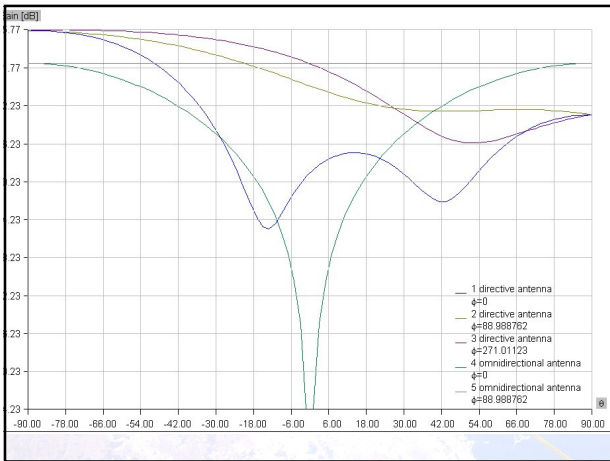
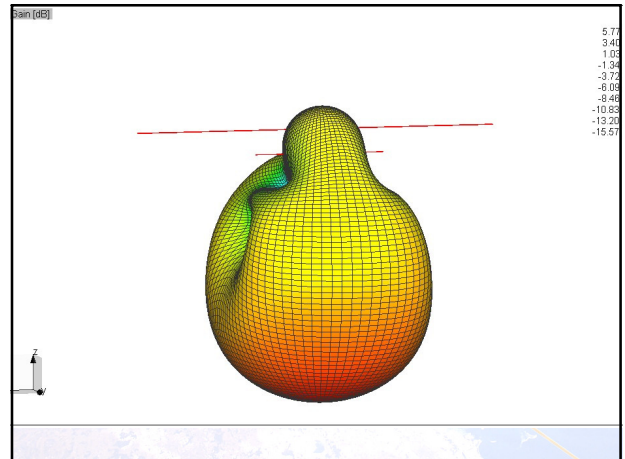
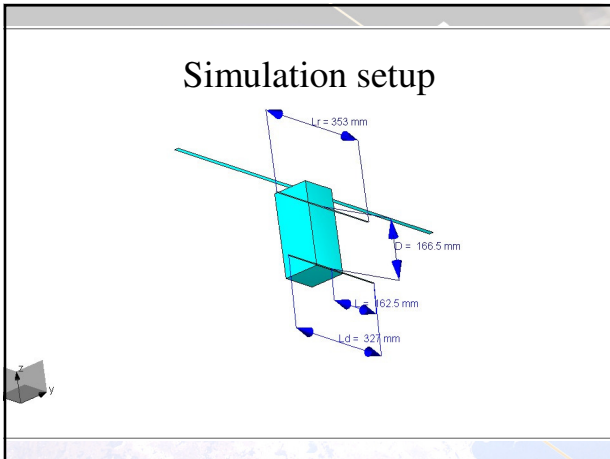

### More information:

- <http://org.ntnu.no/studsat>
- [Studsat@list.stud.ntnu.no](mailto:Studsat@list.stud.ntnu.no)

## **NTNU STUDENT SATELLITE**

### **PROPOSAL FOR MEASUREMENTS OF ELECTRON DENSITY STRUCTURES**

Radar signals are reflected by electron density fine structures in the auroral zone. These irregularities must be produced by particle precipitation and are expected to be aligned with the magnetic field. Very little is known about their scales and the gradients they create. UiO has a leading role in a rocket project aimed at studying these irregularities. One of the experiments on the rocket payload is a Langmuir probe for high time resolution measurements of electron density. Such measurements are of interest for geophysics. However, it is also important to assess the possible disturbance to GPS and the future GALILEO when signals from the satellites pass through the auroral ionosphere.

A light weight experiment consisting of two small cylindrical probes on short booms are proposed for the NTNU Student Satellite. The attached drawing shows a proposal for storage and deployment of two probes, each with a length of 30 mm and a diameter of 1 mm. The probes are connected to current amplifiers and are biased to be at different potentials (for example +2 V and + 3 V) relative to conductive parts on the satellite. With metal surfaces at each end of the satellite and metal bars on the long side corners, is the electric reference area for the probes more than 500 times the probe area. This is sufficient for correct probe functioning. The collected electrons will represent a current in the range  $10^{-8}$  A to  $10^{-6}$  A, and the currents from the two probes must be sampled at approximately 5000 s/s in order to resolve scales of the order 1 m. Data taking over a few minutes in the auroral zone is sufficient. The data can be stored in a memory and later be transmitted to ground at limited data rates.

A first estimate of weight for booms, probes, cabling, release mechanisms, current amplifiers and memory is 100-150 g. Power requirements are very small and the short periods of operation will further limit power usage.

UiO has a prototype boom of the type outlined . It requires more development to check if design limitations can be met. Current amplifiers and connections to memory could be an interesting Masters topic. Successful measurements and data analysis will of course be another interesting Masters topic.

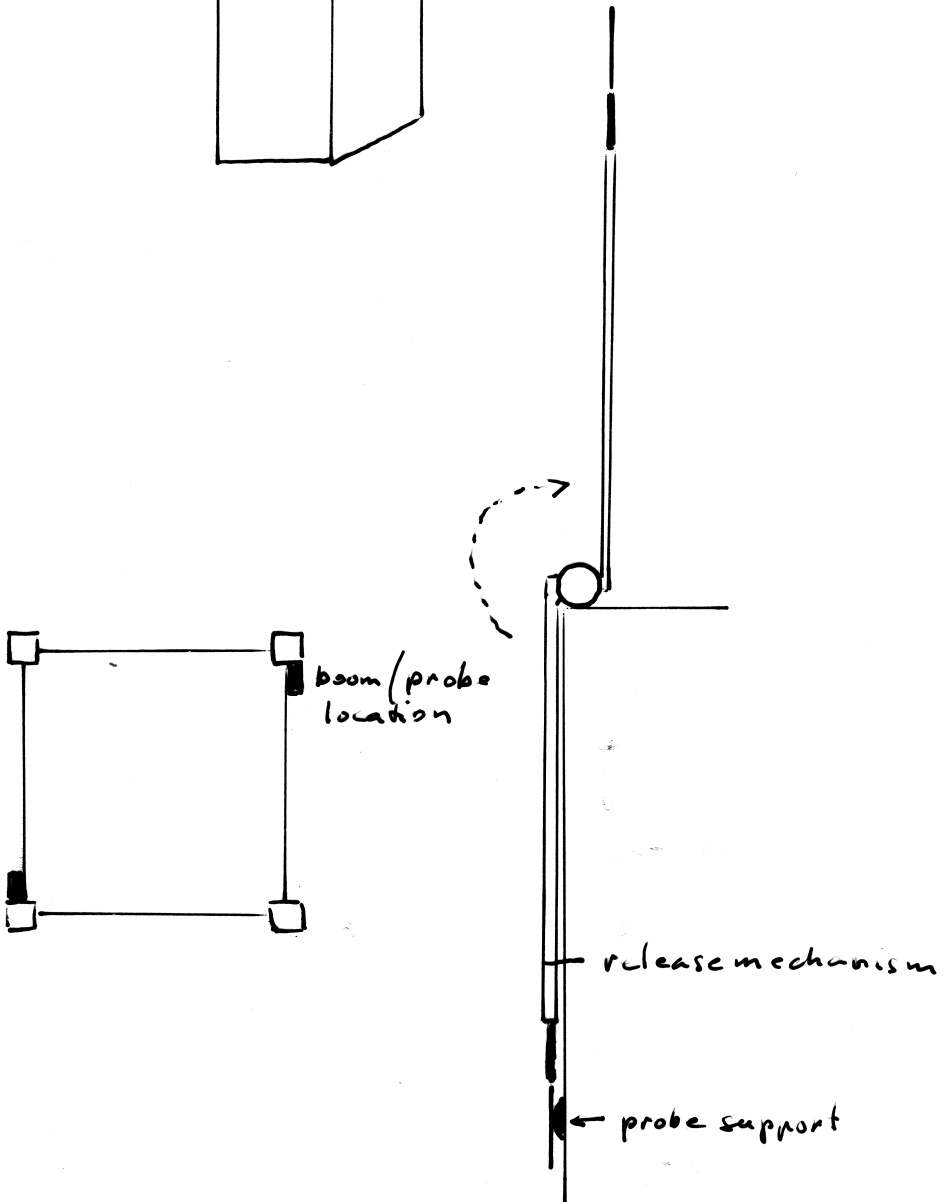
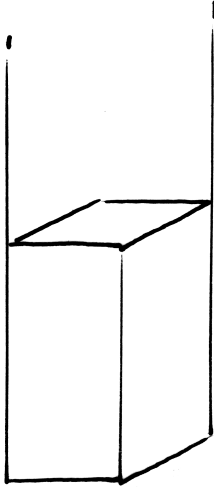

## **Appendix J**

# **Student Presentation**

Presentation held for future students is found in this chapter.



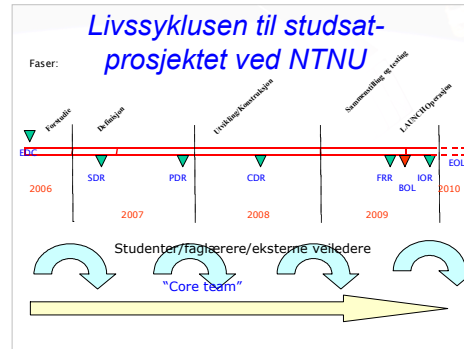

### Background

- A wish for a satellite developed by NTNU
- "Forstudie av liten Lavbanesatellitt"
- NAROM wants successor to NCUBE

- 4 launches in the period 2008-2011
- Co-operation between maximum 2 Norwegian institutions
- Every launch, one contest
- HiN was awarded launch in 2008

### Project Management

- Project spans over 2 years
- Currently involving IET, ITK, IDI
- Want to find participants from other fields
- Assignments as project and masters

ID	Task Name	Start	Finish	Duration	2006												2007												2008												2009												2010											
					01	02	03	04	05	06	07	08	09	10	11	12	01	02	03	04	05	06	07	08	09	10	11	12	01	02	03	04	05	06	07	08	09	10	11	12	01	02	03	04	05	06	07	08	09	10	11	12	01	02	03	04	05	06	07	08	09	10	11	12
1	Preliminary studies and planning	01.09.2006	28.12.2006	85d	█																																																											
2	Application	31.10.2006	06.12.2006	29d	█																																																											
3	Submit application	01.12.2006	01.12.2006	0d	█																																																											
4	Specification Review	15.12.2006	15.12.2006	0d	█																																																											
5	Structure and Flight System Construction	03.01.2007	26.07.2007	147d	█																																																											
6	Preliminary Design Review	01.06.2007	01.06.2007	0d	█																																																											
7	Design of Subsystem Engineering Models	30.08.2007	01.04.2008	154d	█																																																											
8	Preliminary System Function Test	03.03.2008	03.03.2008	0d	█																																																											
9	Critical Design Review	01.04.2008	01.04.2008	0d	█																																																											
10	Flight Model Subsystem Design and Production	01.04.2008	01.08.2008	85d	█																																																											
11	Flight Model Assembly and Testing	01.08.2008	22.06.2009	232d	█																																																											
12	System Function Test	31.12.2008	31.12.2008	0d	█																																																											
13	Launch preparations and launch	09.02.2009	27.07.2009	121d	█																																																											
14	In-Orbit Operations	29.07.2009	31.03.2010	172d	█																																																											
15	Review	08.09.2009	20.04.2010	161d	█																																																											

## Specification Overview

- CubeSat standard
- 2 litre, 2 kg
- 145 MHz (TT&C) and 437 MHz (payload) transceivers
- Stabilized with magnetic coils
- Platform based concept able to carry a multitude of payloads

## Mission Goals

- Deliver a fully functional and tested satellite for launch
- Transmit a beacon signal receivable for radio amateurs
- Establish two-way communication
- Testing attitude control, consisting of magnetic coils
- Capture an image
- Take a picture of Earth
- Transmit the image to the ground

## Recruitment

- The assignments outlined is minimum needed workload
- Is it possible? Are the teachers and students motivated?
- We need to start internal PR campaign in a few weeks
- This work will go on for two more years

## Why?

- Multidisciplinary project to every extent!
- PR for education at NTNU
- Use theories in practice!
- A more tidy project than NCUBE. Locally managed
- Ambitious project...
- ...and FUN!

## Assignments

- Most work to be done as 9<sup>th</sup> semester project and masters theses
- This enables students to be engaged in the project during two consecutive semesters
- Tasks include:
  - Design
  - Simulation
  - Construction
  - Test

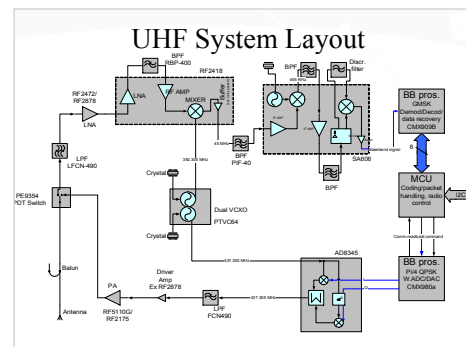



## VHF System Design

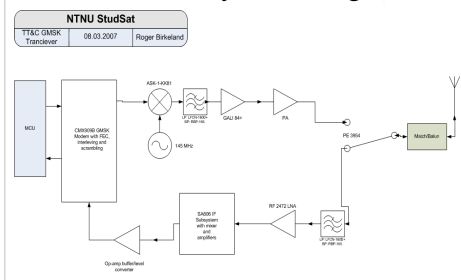

## Antenna System

- IET
- An antenna system is designed. This system must be verified, tested and adjusted if needed. The deployment mechanism must be designed and tested. High priority, autumn 2007
- Extent: Project. 1 person.

## Ground Station

- IET, IDI, ITEM
- We would like to have our own ground station here at NTNU. The station must be specified and constructed. The work can be done in co-operation with Akademisk RadioKlubb here in Trondheim.
- Extent: Project/diploma. 1 or 2 persons.

## TT&C CODEC

- IET, IDI, ITEM
- Operation Procedures, Protocols and Commands
- An important part of the TT&C-system is the software part. The coder and decoder must send and receive data and commands to and from the TT&C radio hardware. The software controlling the satellite, running on the ODBH micro controller, must be developed. Protocols for internal communications, as well as internal and external commands and operating procedures must be defined. The task can be done in combination with the EDAC algorithm development.
- Extent: Project/diploma. 1 or 2 persons.

## OnBoard Data Handling

- IDI, IET, ITK
- The satellite must have an integrated common bus, a central processing unit and central storage. All payload and electrical subsystems must operate on the bus, making it easy to connect modules without excessive re-configuring. High priority, autumn 2007
- Extent: Project/diploma. 1 or 2 persons.

## Power Management System

- IDI, IET, ITK
- Design and build a power management system to control solar panels, battery bank and power consumption. High priority, autumn 2007
- Extent: Project/diploma. 1 or 2 persons.

### Error Detection And Correction, EDAC

- IDI
- It is desirable to develop an EDAC algorithm for the satellite memory, as radiation may cause irregular errors, known as "bit-flips" in the memory registers. The assignment may also include development of memory access protocols. A study of how to minimize the risk of critical latch-ups and other software related problems can also be included.
- Extent: Project/diploma. 1 person.

### Mechanical Modelling and Production

- IPM
- Both the satellite frame structure and the internal layout must be further developed. Some work has already been carried out. Important issues: Vibration, thermal extending/contraction, easy mounting of modules, weight and balance. The design must comply with the CubeSat standard.
- Extent: Project/(diploma). 1 or 2 persons.

### Thermal Modelling

- IFY, IPM
- Although a simple thermal analysis has been conducted, more knowledge of the satellites thermal environment is desirable. A full analysis of the structure would be useful in order to detect possible temperature related problems before launch. Can be done in relation with the mechanical design task.
- Extent: Project/diploma. 1 person.

### Scientific Payload

- IFY, UiO
- The satellite will be built as a "reusable" platform. Other groups are invited to suggest possible payloads. The payload must comply with the existing power, weight and size requirements. Interfaces for power and internal communication must be developed.
- Extent: Project/diploma

