



**NTNU – Trondheim**  
Norwegian University of  
Science and Technology

# New Concept for Durable Concrete Bridges

**Marek Damek**

Civil and Environmental Engineering (2 year)

Submission date: June 2015

Supervisor: Jan Arve Øverli, KT

Co-supervisor: Håvard Johansen, Statens vegvesen  
Terje Kanstad, KT

Norwegian University of Science and Technology  
Department of Structural Engineering





## MASTER THESIS 2015

SUBJECT AREA: Concrete structures	DATE: 9. June 2015	NO. OF PAGES: 122 + 85 Appendix
--------------------------------------	-----------------------	------------------------------------

TITLE:

**New Concept for Durable Concrete Bridges**

Nytt konsept for bestandige betongbruer

BY:

Marek Damek



SUMMARY:

This master's thesis covers the design of a post-tensioned concrete bridge in Trondheim municipality in Norway, in collaboration with Statens vegvesen (SVV). The concept of the bridge is inspired by Egg-Graben-Brücke in Austria, which was designed and built without steel reinforcement in the bridge deck.

The total length of the bridge is 73 meters and it is divided into 3 spans. The cross-section of the bridge is assumed as a massive T-beam/slab with flanges. The width of the cross-section with edge beams is 9,5 meters and the height is 1,3 meters. The bridge is planned to be built in 4 stages and a proposed building process is presented.

The bridge is post-tensioned in longitudinal and transverse direction. Due to the high maintenance costs of bridges, the bridge is designed to use as little steel reinforcement as possible to enhance the durability. The number of prestressing tendons have been determined. The design is according to established standards such as Eurocodes, and Handbook N400 by Statens vegvesen.

Analytical models have been created in the program NovaFrame for longitudinal direction and some parts in the program Scia Engineer for transverse direction.

The master's thesis contains analyses for ultimate limit state and serviceability limit state for critical sections. The capacities and requirements are sufficient in the controlled sections for both limit states.

RESPONSIBLE TEACHER: Jan Arve Øverli

SUPERVISORS: Jan Arve Øverli, NTNU  
Terje Kanstad, NTNU  
Håvard Johansen, Statens vegvesen

CARRIED OUT AT: Norwegian University of Science and Technology  
Department of Structural Engineering



## PREFACE

This master's thesis is part of a 2 year Master program in Civil and Environmental Engineering at the Norwegian University of Science and Technology. It is written at the Department of Structural Engineering in collaboration with Statens vegvesen (Norwegian Public Road Administration).

I would like to thank all the people who have contribute to this master's thesis in the various phases of its development.

Special thanks are due to my master's thesis supervisor Jan Arve Øverli and co-supervisor Terje Kanstad, who helped me not just through the master's thesis itself, but through many academic situations.

Thanks to Håvard Johansen from Statens Vegvesen for his incredible help and his quick responses to my questions.

Thanks to company Aas-Jakobsen for providing the program NovaFrame.

Thanks to my family for their support during my academic years.

Finally, I would like to thank to my girlfriend Victoria, simply for everything.

In Trondheim on 9. June 2015

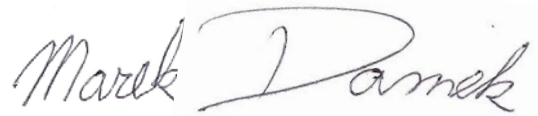

---

Marek Damek



## ABSTRACT

This master's thesis covers the design of a post-tensioned concrete bridge in Trondheim municipality in Norway, in collaboration with Statens vegvesen (SVV). The concept of the bridge is inspired by Egg-Graben-Brücke in Austria, which was designed and built without steel reinforcement in the bridge deck. The idea is to eliminate steel reinforcement which can corrode in the bridge deck.

The total length of the bridge is 73 meters and it is divided into 3 spans. The cross-section of the bridge is assumed as a massive T-beam/slab with flanges. The width of the cross-section with edge beams is 9,5 meters and the height is 1,3 meters. Two carriageways are assumed with width 8,5 meters between restraint systems and kerbs on the bridge. The bridge is planned to be built in 4 stages and a proposed building process is presented.

The bridge is post-tensioned in longitudinal and transverse direction. Due to the high maintenance costs of bridges, the bridge is designed to use as little steel reinforcement as possible to enhance the durability. The number of prestressing tendons have been determined. Cables with 15 strands are used in longitudinal direction. 6 cables are placed in side spans, 10 cables over columns and 8 cables in the middle span. Cables with 2 strands with a spacing of 0,5 meters are placed in the transverse direction. Creep development has been considered for the different construction stages.

The design is according to established standards such as Eurocodes, and Handbook N400 by Statens vegvesen.

The purpose of this master's thesis is for the candidate to familiarize himself in calculation methods, by performing a literature study of relevant regulations and the use of manual calculation methods.

Analytical models have been created in the program NovaFrame for longitudinal direction and some parts in the program Scia Engineer for transverse direction. Verifications of the results from NovaFrame are presented.

The master's thesis contains analyses for ultimate limit state and serviceability limit state for critical sections. The bending moments, shear and torsional capacities have been calculated in the ultimate limit state. The stress limitations and crack width have been calculated in the serviceability limit state. All hand calculations are shown in Appendices.

The capacities and requirements are sufficient in the controlled sections for both limit states.





## SAMMENDRAG

Denne masteroppgaven dekker prosjektering av en etterspent betongbru i Trondheim i Norge. Oppgaven er skrevet i samarbeid med Statens vegvesen. Konseptet for brua er inspirert av Egg-Graben-Brücke i Østerrike, som ble designet og bygget uten slakkarmering i bruplaten. Idéen går ut på å unngå bruk av slakkarmering som kan korrodere i brudekket.

Brua har en total lengde på 73 meter og den består av tre spenn. Bruas tverrsnitt er en massiv T-seksjon utformet som en bjelke/dekke med vinger. Bredden av tverrsnittet med kantdragere er 9,5 meter og tverrsnitthøyden er 1,3 meter. Brua har to kjørefelt og bredden mellom rekkverkene er 8,5 meter. Brua bygges i fire byggefaser og foreslått byggemåte er presentert.

Brua er etterspent i lengde- og tverretning. På grunn av høye vedlikeholdkostnader, er brua prosjektert for å bruke så lite slakkarmering som mulig for å bedre bestandighet. Spennkabler med 15 tau i lengderetning og 2 tau i tverretning er valgt med følgende plassering; 6 spennkabler i endefeltene, 8 i midtfeltet og 10 over støttene. Spennkablene i tverretningen er plassert med 500 mm mellomrom. Kryputvikling har blitt gjennomgått for de forskjellige byggefasetene.

Brua er prosjektert i henhold til etablerte standarder som Eurokode samt Håndbok N400 utarbeidet av Statens vegvesen Vegdirektoratet.

Hensikten med denne masteroppgaven for kandidaten er å orientere seg i beregningsmetoder ved å utføre en litteraturstudie av relevant regelverk og ved bruk av manuelle beregningsmetoder.

Analysemodeller er etablert i programmet NovaFrame for lengderetningen, og noen deler av brua er modellert i programmet Scia Enginner for tverretningen. Verifikasjoner av resultatene fra NovaFrame er presentert.

Masteroppgaven omhandler kontroll av brua i brudd- og bruksgrensetilstand for de mest kritiske seksjonene. I bruddgrensetilstanden er bøyemoment-, skjær- og torsjonskapasiteten kontrollert. I bruksgrensetilstand er spenningsbegrensning, og rissviddebegrensning kontrollert. Alle håndberegninger er vist i appendiks.

Alle kapasiteter og krav er tilfredsstillende oppfylt i alle de kontrollerte seksjonene for begge grensetilstandene.



# TABLE OF CONTENTS

Preface .....	I
Abstract .....	III
Sammendrag .....	V
Table of Contents .....	VII
List of Figures .....	XI
List of Tables .....	XIII
1 Introduction .....	1
2 Project Basis .....	3
2.1. Standards .....	3
2.2. European technical approval (ETA) .....	3
2.3. Handbook provided by Statens Vegvesen .....	3
2.4. Programs .....	4
3 Material properties .....	5
3.1. Concrete .....	5
3.2. Reinforcing steel .....	5
3.3. Prestressing steel .....	6
3.4. Concrete cover .....	8
4 Bridge .....	11
4.1. Design of the bridge .....	11
4.2. Static model .....	12
4.3. Position of the prestressing system .....	12
4.4. Construction stages .....	17
5 Prestressing system .....	21
5.1. Ducts .....	21
5.2. Anchorages .....	22
5.3. Coupler .....	24
5.4. Stressing .....	25
5.5. Grouting .....	25
6 Prestress losses .....	27

6.1.	Short-term losses.....	27
6.2.	Long-term losses .....	29
7	Loads.....	31
7.1.	Self-weight.....	31
7.2.	Self-weight – other .....	31
7.3.	Traffic loads .....	31
7.4.	Wind .....	36
7.5.	Temperature .....	38
7.6.	Creep.....	40
7.7.	Shrinkage .....	42
7.8.	Load combination .....	43
8	NovaFrame.....	49
8.1.	Preprocessor .....	49
8.2.	Solve.....	60
8.3.	Postprocessor.....	61
9	Verifications of the analytical model in NovaFrame .....	63
9.1.	Self-weight.....	63
9.2.	Traffic load.....	65
9.3.	Wind load.....	67
9.4.	Temperature load .....	68
9.5.	Prestressing.....	69
10	Ultimate limit state (ULS).....	73
10.1.	Effective flange width.....	73
10.2.	Analysis results .....	74
10.3.	Moment capacity .....	82
10.4.	Shear capacity.....	85
10.5.	Torsion capacity .....	86
11	Serviceability limit states (SLS) .....	87
11.1.	General.....	87
11.2.	Analysis results .....	89
11.3.	Stress limitations .....	94
11.4.	Crack control .....	97

12	Conclusion .....	99
12.1.	Further work.....	101
13	References.....	103
14	List of Appendices.....	105

X

## LIST OF FIGURES

Figure 1 Positions of multiplane anchorages MA and couplers R in the construction joint .....	7
Figure 2 Minimum clear spacing between ducts [7].....	7
Figure 3 Position of prestressing and reinforcing steel – top surface .....	9
Figure 4 Position of prestressing and reinforcing steel – bottom surface .....	9
Figure 5 Side view .....	11
Figure 6 Cross-section of the bridge deck .....	12
Figure 7 Static model of the bridge .....	12
Figure 8 Geometry of a parabolic cable [12].....	13
Figure 9 Position of cables and anchorages .....	14
Figure 10 Position of bond head anchorages H 6815.....	15
Figure 11 Horizontal position of prestressing system .....	15
Figure 12 Horizontal position of cables in the transverse direction.....	16
Figure 13 Position of cables in the transverse direction over supports.....	16
Figure 14 Construction stages .....	17
Figure 15 Example of casted duct ready for next stage [20].....	18
Figure 16 Example of preparation of couplers R with strands. [20] .....	19
Figure 17 Corrugated Duct [14].....	21
Figure 18 Flat PE/PP Duct [14] .....	22
Figure 19 Multiplane Anchorage MA [14].....	22
Figure 20 CAD detail of Multiplane Anchorage MA 6815 .....	23
Figure 21 Bond head anchorage details and position [14].....	23
Figure 22 Flat Multiplane Anchorage FMA [14].....	24
Figure 23 Coupler R [14].....	24
Figure 24 Coupler R CAD detail.....	25
Figure 25 Jack 5400 [14].....	25
Figure 26 Short-term losses for the cable from the 1 <sup>st</sup> stage. ....	27
Figure 27 Application of LM1 and positions of the carriageway lanes .....	33
Figure 28 Position of LM1 .....	33
Figure 29 Position of LM2 – top view .....	34
Figure 30 Position of LM2 .....	34
Figure 31 Creep coefficient 0 – 112 days .....	40
Figure 32 Creep coefficient 0 – 36500 days .....	41
Figure 33 Cross section of the deck, with points and their coordinates.....	51
Figure 34 Node numbers.....	51
Figure 35 Element numbers .....	52
Figure 36 Detail of the boundaries and joints in axis 1 .....	53
Figure 37 Position of cable group 1 in the edge span.....	54
Figure 38 Position of cable group 2 in the middle span .....	54
Figure 39 Position of cable group 3 in the middle span with shown connection to the cable group 1..	54
Figure 40 Position of cable group 4 in the edge span.....	54
Figure 41 Position of cable group 5 in the side span with shown connection to the cable group 2.....	55
Figure 42 Relaxation curve in NovaFrame [16].....	55
Figure 43 Temperature gradient [16] .....	57
Figure 44 The definition of tracks end eccentricities. The traffic load is positioned at $e_{max}$ or $e_{min}$ . [10]	58
Figure 45 Eccentricities for load model 1 .....	58
Figure 46 Eccentricities for load model 2 .....	58
Figure 47 Model for 1 <sup>st</sup> stage.....	59
Figure 48 Model for 2 <sup>nd</sup> stage.....	59
Figure 49 Model for final stage.....	60

Figure 50 Static model.....	63
Figure 51 Moment diagram for self-weight in NovaFrame .....	64
Figure 52 Shear diagram for self-weight in NovaFrame.....	64
Figure 53 Position of load model LM1- maximum support moment.....	65
Figure 54 Position of load model LM1- maximum span moment .....	65
Figure 55 Moment diagram for load model LM1 in NovaFrame.....	66
Figure 56 Moment diagram for load model LM1 in Scia Engineer .....	66
Figure 57 Moment diagram for wind load in NovaFrame .....	67
Figure 58 Shear diagram for wind load in NovaFrame.....	67
Figure 59 Moment diagram for temperature gradient $\Delta T_{\max} = 15^\circ$ in NovaFrame .....	68
Figure 60 Moment diagram for temperature gradient $\Delta T_{\max} = 15^\circ$ in Scia Engineer.....	68
Figure 61 Simplified cable for short-term losses check in NovaFrame .....	71
Figure 62 Simplified cable for short-term losses check in Scia Engineer .....	71
Figure 63 Short term losses in Scia Engineer .....	72
Figure 64 Definition of $l_0$ for the calculation of the effective flange width [7].....	73
Figure 65 Effective flange width parameters [7].....	73
Figure 66 Position of neutral axis in cross-section in span and over support .....	74
Figure 67 Axial force diagram – Parasite prestressing.....	75
Figure 68 Shear force diagram – Parasite prestressing.....	75
Figure 69 Bending moment diagram – Parasite prestressing .....	75
Figure 70 Torsional moment diagram – Parasite prestressing .....	75
Figure 71 Axial force diagram – Full prestressing .....	76
Figure 72 Shear force diagram – Full prestressing .....	76
Figure 73 Bending moment diagram – Full prestressing.....	76
Figure 74 Torsional moment diagram – Full prestressing.....	76
Figure 75 Position of Tandem system - LM1.....	78
Figure 76 Bending moment – Tandem system load LM1.....	78
Figure 77 Bending moment – UDL system LM1 .....	79
Figure 78 Position of LM2.....	80
Figure 79 Bending moment - LM2.....	80
Figure 80 Simplified cross-section for torsion resistance .....	86
Figure 81 1 <sup>st</sup> stage of stress-strain behaviour - section uncracked.....	87
Figure 82 2 <sup>nd</sup> stage of stress-strain behaviour - section cracked .....	88
Figure 83 Axial force diagram - Characteristic combination.....	90
Figure 84 Shear force diagram - Characteristic combination.....	90
Figure 85 Bending moment diagram - Characteristic combination .....	90
Figure 86 Torsional moment diagram - Characteristic combination.....	90
Figure 87 Axial force diagram - Frequent combination .....	91
Figure 88 Shear force diagram - Frequent combination.....	91
Figure 89 Bending moment diagram - Frequent combination .....	91
Figure 90 Torsional moment diagram - Frequent combination .....	91
Figure 91 Axial force diagram - Quasi-permanent combination.....	92
Figure 92 Shear force diagram - Quasi-permanent combination .....	92
Figure 93 Bending moment diagram - Quasi-permanent combination .....	92
Figure 94 Torsional moment diagram - Quasi-permanent combination.....	92
Figure 95 Maximal axial force and bending moment from transverse prestressing.....	93
Figure 96 Stress distribution for quasi-permanent load combination over the support.....	97



## LIST OF TABLES

Table 3.1 Properties of concrete .....	5
Table 3.2 Properties of reinforcing steel .....	5
Table 3.3 Properties of prestressing steel – longitudinal direction.....	6
Table 3.4 Properties of prestressing steel – transverse direction.....	6
Table 3.5 Minimal distances for Multiplane anchorage MA .....	7
Table 7.1 LM1 – characteristic values [8].....	32
Table 7.2 Assessment of characteristic values of multi-component action [2] .....	36
Table 7.3 Information for wind load calculation.....	36
Table 7.4 Summary of wind load forces.....	38
Table 7.5 Creep coefficient for different construction stages.....	41
Table 7.6 Recommended values of $\psi$ factors for road bridges [2].....	43
Table 7.7 ULS load combination .....	47
Table 7.8 SLS characteristic load combination .....	47
Table 7.9 SLS frequent load combination .....	48
Table 7.10 SLS quasi-permanent load combination .....	48
Table 9.1 Comparison between NovaFrame and hand calculation results for the bending moment ...	64
Table 9.2 Comparison between NovaFrame and hand calculation results for the shear forces .....	64
Table 9.3 Comparison between NovaFrame and Scia Engineer results for the traffic load .....	66
Table 9.4 Comparison between NovaFrame and hand calculation results for the wind load.....	67
Table 9.5 Comparison between NovaFrame and Scia Engineer results for the temperature load .....	68
Table 9.6 Comparison between NovaFrame and hand calculation results for the temperature load...	68
Table 9.7 Comparison between NovaFrame and hand calculation results for the primary moment....	70
Table 9.8 Comparison between NovaFrame and hand calculation results for the friction loss at the left end.....	71
Table 9.9 Comparison between NovaFrame and hand calculation results for the anchorage slip at the right end.....	71
Table 9.10 Comparison between NovaFrame and hand calculation results for the long-term losses..	72
Table 10.1 Effective flange widths.....	73
Table 10.2 Cross-section properties .....	74
Table 10.3 Maximum bending moment and shear force from self-weight .....	79
Table 10.4 Maximum bending moment and shear force from load model 1.....	79
Table 10.5 Maximum bending moment and shear force from load model 2.....	80
Table 11.1 Stresses in concrete.....	94
Table 11.2 Stress limitations over the support .....	95
Table 11.3 Stress limitations in the side span.....	95
Table 11.4 Stress limitations in the transverse direction.....	96
Table 11.5 Recommended values of $w_{max}$ .....	97
Table 12.1 Summary of ULS.....	99
Table 12.2 Summary of SLS .....	100



# 1 INTRODUCTION

This master's thesis covers the design a post-tensioned concrete bridge in Trondheim municipality in Norway. The total length of the bridge is 73 meters and it is divided into 3 spans. The cross-section of the bridge is assumed to be a massive T-beam/slab with flanges. The materials for the purpose of design are concrete, prestressing steel and reinforcing steel. The bridge is post-tensioned in longitudinal and transverse direction.

Generally the use of post-tensioning delivers the maximum cost-benefit for a project and has as well a beneficial impact on its sustainability and CO2 emissions during construction. Compared with conventional reinforced concrete slabs, the use of post-tensioning results in more durable structures with reduced concrete volumes, lowering the CO2 emissions by up to 37%. [22]

The dimensions of the bridge are collected from Appendix A, which was given by Statens vegvesen (SVV). The number of tendons have been changed and don't correspond to the drawing in Appendix A. The amount of tendons are presented in the master's thesis

Due to the high maintenance costs of bridges, the bridge is designed to use as little steel reinforcement as possible to enhance the durability. The minimum reinforcement is provided according to NS-EN 1992-1-1. If possible, calculations are carried out without steel reinforcement. There is a need for steel reinforcement in anchorages regions.

The chosen prestressing system with detailed position of cables, anchorages and couplers and information about them are presented. Prestress losses are explained.

Load cases such as self-weight, traffic, wind, temperature creep and shrinkage are considered and load combinations for both limit states are used.

An analytical model is created in NovaFrame for longitudinal direction and in Scia Engineer for transverse direction. An explanation of how to create an analytical model in NovaFrame is a part of this master's thesis. The results from both programs give necessary design values for calculation in both limit states.

Verifications of some load cases are presented in this master's thesis.

All necessary analyses are carried out for the most critical section in both directions.

The bending moments, shear and torsional capacities are calculated in ultimate limit state (ULS). The stress limitations and crack width have been calculated in serviceability limit state (SLS).

A summary of capacities' utilization is given in the conclusion.



## 2 PROJECT BASIS

The following standards below have been used.

### 2.1. Standards

NS-EN 1990:2002+NA:2008 Eurocode: Basis of structural design (EN 1990)

NS-EN 1990:2002/A1:2005+NA:2010 Amendment A1 Eurocode: Basis of structural design (EN 1990A)

NS-EN 1991-1-1:2002+NA:2008 Eurocode 1: Actions on structures, Part 1-1:General actions Densities, self-weight, imposed loads for buildings (EN 1991-1-1)

NS-EN 1991-1-4:2005+NA:2009 Eurocode 1: Actions on structures, Part 1-4: General actions, Wind actions (EN 1991-1-4)

NS-EN 1991-1-5:2003+NA:2008 Eurocode 1: Actions on structures, Part 1-4: General actions, Thermal actions (EN 1991-1-5)

NS-EN 1991-2:2003+NA:2010 Eurocode 1: Actions on structures, Part 2: Traffic loads on bridges (EN 1991-2)

NS-EN 1992-1-1:2004+NA:2008 Eurocode 2: Design of concrete structures, Part 1-1: General rules and rules for buildings (EN 1992)

NS-EN 1992-2:2005+NA:2010 Eurocode 2: Design of concrete structures, Concrete bridges, Design and detailing rules (EN 1992-2)

### 2.2. European technical approval (ETA)

ETA-06/0022 DYWIDAG Bonded Post -Tensioning System for 3 to 37 Strands (140 and 150 mm<sup>2</sup>) (ETA-06/0022)

### 2.3. Handbook provided by Statens Vegvesen

Håndbok N400: Bruprosjektering, Prosjektering av bærende konstruksjoner i det offentlige vegnettet (N400)

## 2.4. Programs

NovaFrame 5 is an analysis software which is based on beam theory. A model is built in this program for the longitudinal direction of the bridge.

Scia Engineer 14 is an integrated, multi-material structural analysis and design software for all kinds of projects, mainly used for the transverse direction. The program allows FEM analysis which is needed.

Mathcad Prime 3.0 is a calculation program, used for hand calculations.

AutoCAD 2015 is used for drawing

## 3 MATERIAL PROPERTIES

The main materials for the project of the bridge are concrete and prestressing steel. If there is a need for a reinforcing steel, the material properties are attached.

The material properties are acquired from EN 1992-1-1 [7] and ETA-06/0022 [9].

### 3.1. Concrete

The class of the concrete is B45 (C45/55) with material properties given in Table 3.1

Table 3.1 Properties of concrete

Concrete B45 (C45/55)			
Characteristic compressive cylinder strength of concrete at 28 days	$f_{ck}$	45	MPa
Design value of concrete compressive strength $f_{cd}=\alpha_{cc} \cdot f_{ck}/\gamma_s$	$f_{cd}$	25,5	MPa
Characteristic compressive cube strength of concrete at 28 days	$f_{ck,cube}$	55	MPa
Mean value of concrete cylinder compressive strength	$f_{cm}$	53	MPa
Mean value of axial tensile strength	$f_{ctm}$	3,8	MPa
Characteristic axial tensile strength	$f_{ctk,0,05}$	2,7	MPa
Design axial tensile strength $f_{ctd}=\alpha_{ct} \cdot f_{ctk,0,05}/\gamma_s$	$f_{ctd}$	1,53	MPa
Modulus of elasticity	$E_{cm}$	36	GPa
Ultimate compressive strain in the concrete	$\epsilon_{cu1}$	3,5	‰
Partial safety factor for concrete	$\gamma_c$	1,5	-
Coefficient	$\alpha_{cc}$	0,85	-
Coefficient	$\alpha_{ct}$	0,85	-

### 3.2. Reinforcing steel

The class of the reinforcing steel is B500 NC with properties as listed in Table 3.2.

The projected diameter of the reinforcing steel in longitudinal direction is 25 mm. The spacing of longitudinal reinforcement is 200 mm. The minimal amount of reinforcing steel is given in Appendix C

Table 3.2 Properties of reinforcing steel

B 500 NC			
Characteristic yield strength of reinforcement	$f_{yk}$	500	MPa
Design yield strength of reinforcement $f_{yd}=\frac{f_{yk}}{\gamma_s}$	$f_{yd}$	434	MPa
Modulus of elasticity	$E_s$	200	GPa
Partial safety factor for reinforcing steel	$\gamma_s$	1,15	

### 3.3. Prestressing steel

The class of the prestressing steel is Y1860 S7. The amount of prestressing steel is given by SVV. The properties of prestressing steel in longitudinal direction are shown in Table 3.3, and in transverse direction in Table 3.4. The difference between prestressing steel in longitudinal and transverse direction is only the number of strands, thus prestressing forces.

Maximum stresses are calculated according to EN 1992-1-1 section 5.10

$$\sigma_{p,max} = \min(k_1 * f_{pk}, k_2 * f_{p0,1k}) = \min(0,8 * 1860, 0,9 * 1600) = \min(1488, 1440) = 1440 \text{ MPa}$$

$$\sigma_{pm0} = \min(k_1 * f_{pk}, k_2 * f_{p0,1k}) = \min(0,75 * 1860, 0,85 * 1600) = \min(1395, 1360) = 1360 \text{ MPa}$$

Table 3.3 Properties of prestressing steel – longitudinal direction

Y1860 S7		
Tendon design nation	6815	
Number of strands	n	15
Cross section - 1 strand	A	150 mm <sup>2</sup>
Cross section - total	A <sub>p</sub>	2250 mm <sup>2</sup>
Characteristic tensile strength of prestressing steel	f <sub>pk</sub>	1860 MPa
Characteristic 0,1% proof-stress of prestressing steel	f <sub>p0,1k</sub>	1600 MPa
Design tensile strength f <sub>pd</sub> = f <sub>p0,1k</sub> /γ <sub>s</sub>	f <sub>pd</sub>	1391 MPa
Maximum stress applied to tendon	σ <sub>p,max</sub>	1440 MPa
Maximum force P <sub>0,max</sub> = A <sub>p</sub> * σ <sub>p,max</sub>	P <sub>0,max</sub>	3240 kN
Stress in tendon immediately after tensioning or transfer	σ <sub>pm0</sub>	1360 MPa
Initial prestressing force P <sub>m0,max</sub> = A <sub>p</sub> * σ <sub>pm0</sub>	P <sub>m0,max</sub>	3060 kN
Modulus of elasticity	E <sub>p</sub>	195000 GPa
Partial factor for reinforcing or prestressing steel	γ <sub>s</sub>	1,15

Table 3.4 Properties of prestressing steel – transverse direction

Y1860 S7		
Tendon design nation	6802	
Number of strands	n	2
Cross section - 1 strand	A	150 mm <sup>2</sup>
Cross section - total	A <sub>p</sub>	300 mm <sup>2</sup>
Maximum force P <sub>0,max</sub> = A <sub>p</sub> * σ <sub>p,max</sub>	P <sub>0,max</sub>	432 kN
Initial prestressing force P <sub>m0,max</sub> = A <sub>p</sub> * σ <sub>pm0</sub>	P <sub>m0,max</sub>	408 kN



### 3 Material properties

#### 3.3.1. Minimal distances

The minimal distances for multiplane anchorage MA are calculated according to ETA 06/0022 Annex 9 and are shown in Table 3.5.

The edge distance for multiplane anchorage MA is calculated as:

$$\text{Edge distance} = 0,5 * \text{Center distance} + \text{Concrete cover} - 10 \text{ mm}$$

According to EN 1992-1-1 and Figure 2 the minimal distance between ducts is 100 mm.

The minimum centre distance between bond head anchorages H 6815 is 475 mm. [14]

The position of cables and anchorages meet the criteria for minimal distances

Table 3.5 Minimal distances for Multiplane anchorage MA

Minimal actual concrete strength at stressing [MPa]	23	33	32
Center distance [mm]	470	395	400
Edge distance [mm]	315	278	280

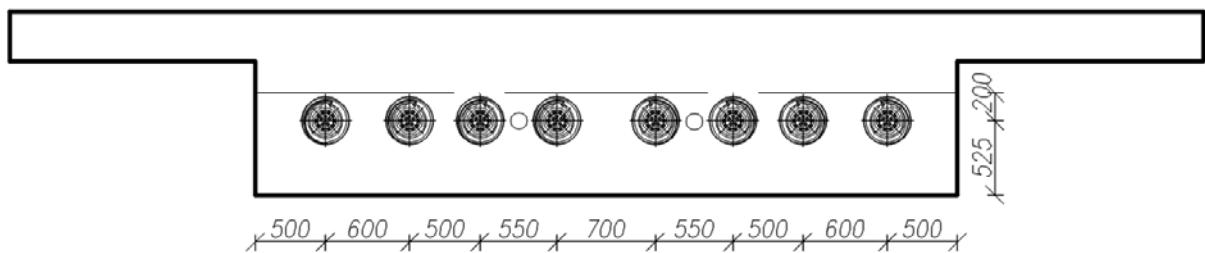

Figure 1 Positions of multiplane anchorages MA and couplers R in the construction joint

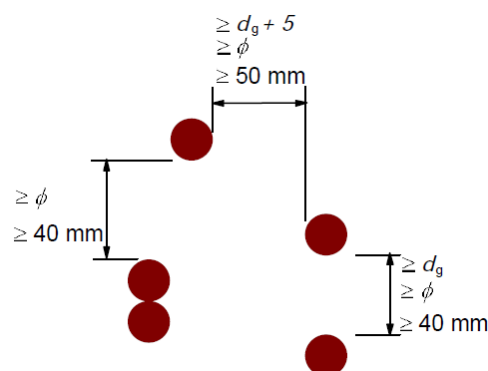

Figure 2 Minimum clear spacing between ducts [7]

### 3.4. Concrete cover

The bridge in this master's thesis is exposed to two different exposure classes. The top surface is exposed to class XD1 and the bottom surface to class XC3. The design for concrete cover is a combination between N400 and EN 1992.

The nominal cover is defined as a minimum cover  $c_{min}$ , plus an allowance in design for deviation  $\Delta c_{dev}$

$$c_{nom} = c_{min} + \Delta c_{dev}$$

Minimum cover shall ensure safe transmission of bond forces and protection of the steel against corrosion.

$$c_{min} = \max(c_{min,b}; c_{min,dur} + \Delta c_{dur,\gamma} - \Delta c_{dur,st} - \Delta c_{dur,add}; 10 \text{ mm})$$

Design for deviation:

$$\Delta c_{dev} = 10 \text{ mm for EN 1992}$$

$$\Delta c_{dev} = 15 \text{ mm for N400, } c_{min} < 70 \text{ mm}$$

$$\Delta c_{dev} = 20 \text{ mm for N400, } c_{min} \geq 70 \text{ mm}$$

#### Top surface XD1

For prestressing steel

$$c_{nom} = 100 \text{ mm N400 (90 mm EN 1992)}$$

For reinforcing steel

$$c_{nom} = 75 \text{ mm N400 (70 mm EN 1992)}$$

#### Bottom surface XC3

For prestressing steel

$$c_{nom} = 100 \text{ mm N400 (90 mm EN 1992)}$$

For reinforcing steel

$$c_{nom} = 65 \text{ mm N400 (60 mm EN 1992)}$$

#### Transverse direction

$$c_{nom} = 90 \text{ mm N400 (80 mm EN 1992)}$$

The values are collected from Appendix D

### 3 Material properties

Figure 3 and Figure 4 show the positions of ducts and reinforcing steel in the cross-section and their distances from the top and bottom edges. The minimal concrete cover requirements are achieved.

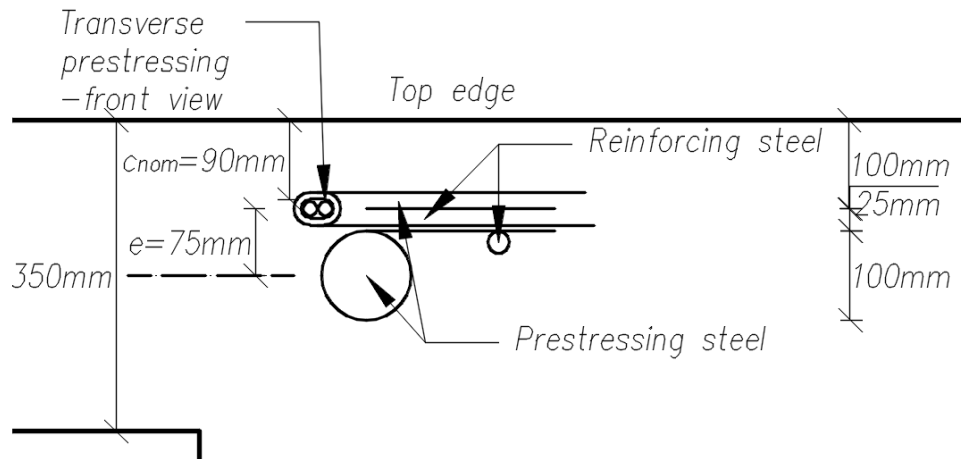

Figure 3 Position of prestressing and reinforcing steel – top surface

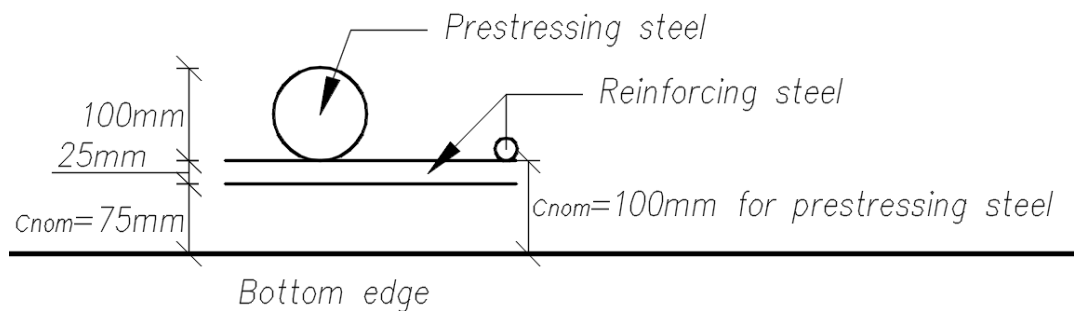

Figure 4 Position of prestressing and reinforcing steel – bottom surface



## 4 BRIDGE

The dimensions of the cross-sections, bridge and position of the prestressing system will be given in this chapter. Building stages will be explained and presented.

The bridge is designed as 3 spans of post-tensioned beams/slabs with a constant cross-section, to be built in 4 stages. The flanges are also post-tensioned in transverse direction. The bridge is designed to use as little ordinary reinforcement as possible. The location of the bridge in this master's thesis is in the Trondheim municipality (only relevant for wind load calculation).

### 4.1. Design of the bridge

The total length of the bridge is 75 meters. The span between axes 1-2 and 3-4 is 22,5 m. The span between axes 2-3 is 28 m. The cross-section is a T profile with height 1,3 m, total width 8,5 m, width of the web 5 m and thickness of the flanges 350 mm. The cross-section is constant and is shown in Figure 6. The bearing in axis 1 allows only rotation and the bearing in axis 4 allows rotation and movement in longitudinal direction. The columns in axis 2 and 3 have rectangular cross-sections of 5 m x 0,8 m, and in axis 1 and 4 the dimension is 7,5 m x 0,6 m. The connection between the columns and the slab are monolithic. The construction joints are placed in distance 5,6 m right from axis 2 and 3. The overview of the bridge is shown in Figure 5.

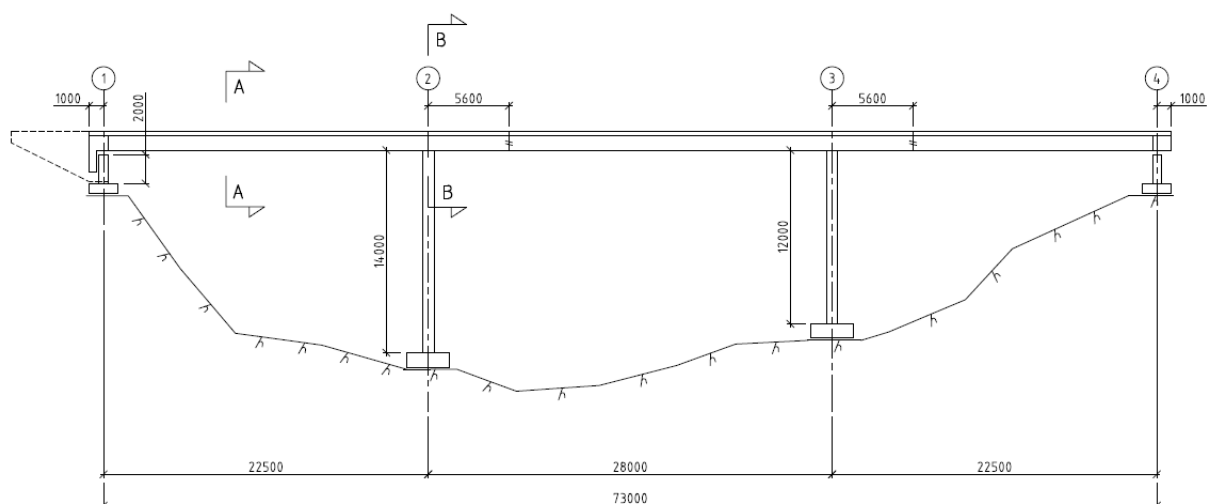

Figure 5 Side view

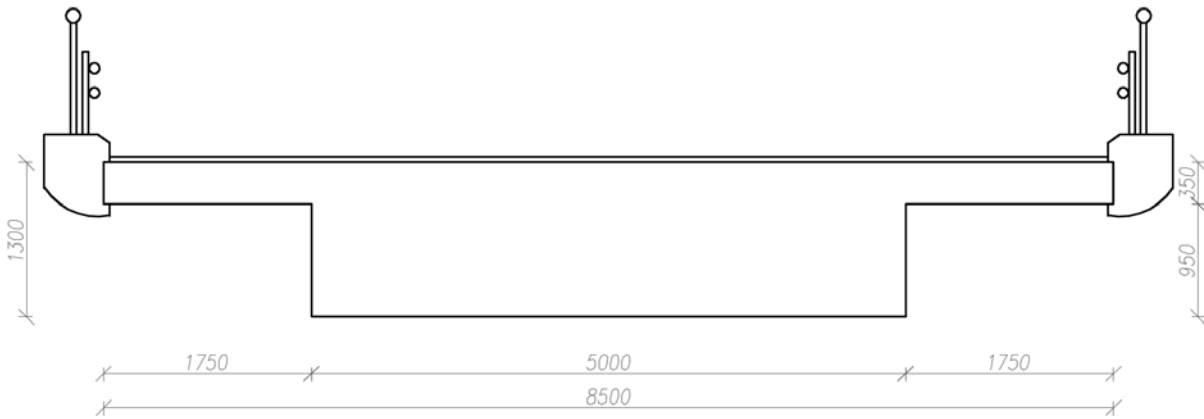

Figure 6 Cross-section of the bridge deck

## 4.2. Static model

The static model describes the structure of the bridge, shown in Figure 7. The model will be used in NovaFrame.

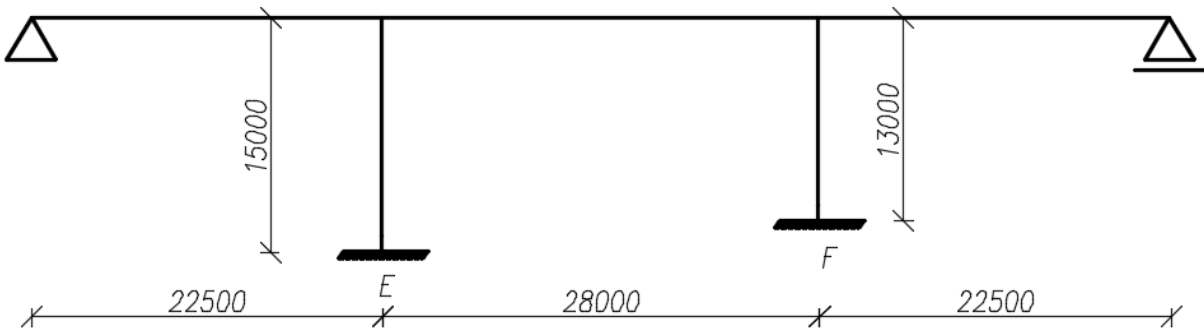

Figure 7 Static model of the bridge

## 4.3. Position of the prestressing system

The maximum eccentricity in side span is approximately 0,4 of a length of the side span from the edge support, according to Figure 8 which is showing the location and the maximum eccentricity in side span,  $e_p$ , from the edge support. The eccentricities are calculated depending on the concrete cover for steel reinforcement and the ducts. The eccentricity in side and middle span is 575 mm. The eccentricity over the supports in axis 2 and 3 is 400 mm. The minimal radius of curvature for a duct with an inner diameter of 90 mm is 7,2 m [15]. From these values the geometry is acquired. The calculation is found in Appendix E. The final position of all cables are shown in Figure 36 to Figure 41.

## 4 Bridge

The anchorages in axis 1 are passive end accessible anchorages. The anchorages in axis 4 are stressing anchorages. The anchorages in axes 1 and 4 are placed in the neutral axis of the cross section (725 mm from the lower edge). The ducts in the spans are 100 mm from the lower edge (150 mm distance from the lower edge to the centre of the duct) because of the requirement for minimal concrete cover of ducts. The ducts in axes 2 and 3 are placed 125 mm from the upper edge (175 mm distance from the upper edge to the centre of the duct). The couplers and multiplane anchorages, MA, are placed 525 mm from the lower edge in the construction joints. The distance between ducts and anchorages meet the requirements of minimal distances see 3.3.1.

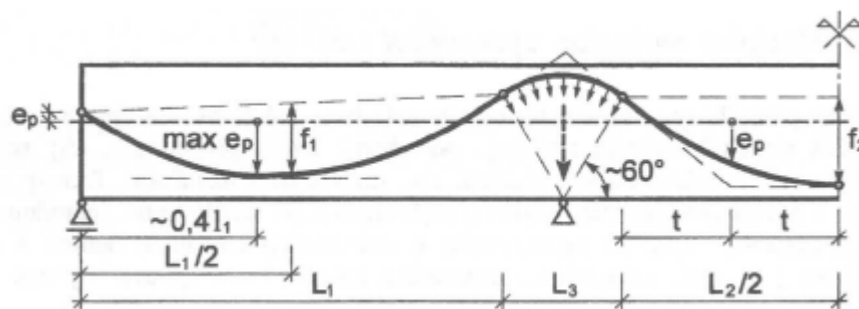

Figure 8 Geometry of a parabolic cable [12]

The ducts and tendons in the transverse direction are placed above the ducts in the longitudinal direction. The anchorages in the transverse direction are placed in the neutral axis of the flange (175 mm from the upper edge) and they have a maximum eccentricity of 75 mm. Tendons are spaced at regular, frequent intervals accurately 500 mm along the length of the structure as shown in Figure 12.

4 couplers of type R are placed in the construction joint 5,6 m from axis 3. The total amount of cables passing through in this construction joint is 6. 66,6% of the cables are coupled in this joint.

According to EN 1992-2 section NA8.10.4(105), the maximum amount of cables couples in one construction joint is 67 %. In the construction joint 5,6 m from axis 2 this amount is 50%.

The positions of bond head anchorages are shown in Figure 10. The anchorages are placed between passing ducts.

A summary of the prestressing system is shown in Figure 9 to Figure 13 below.

More details about the prestressing system in Chapter 5 Prestressing system

4 Bridge

Axis 1

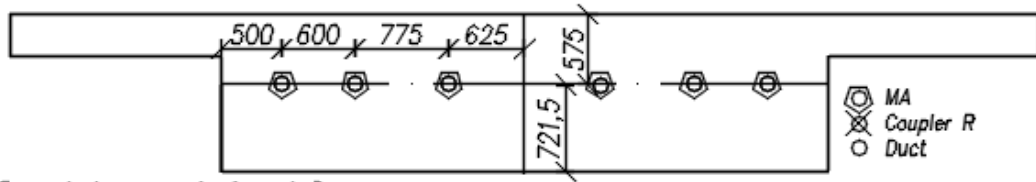

Span between axis 1 and 2

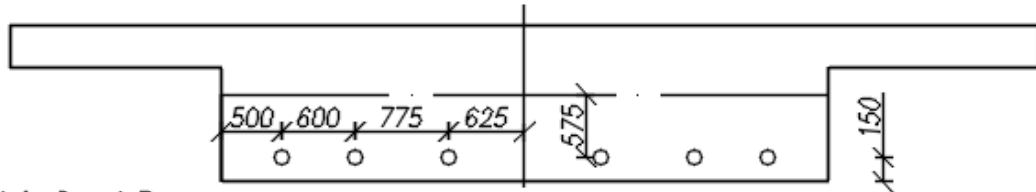

Axis 2 and 3

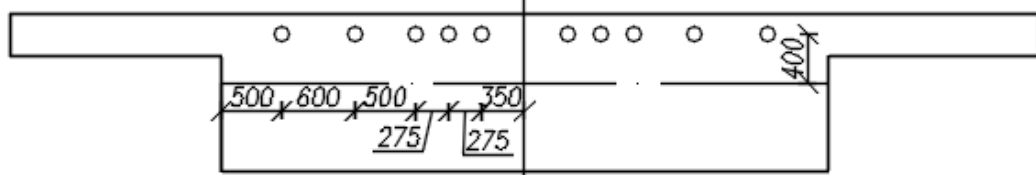

Construction joint 5,8 m right from axis 2

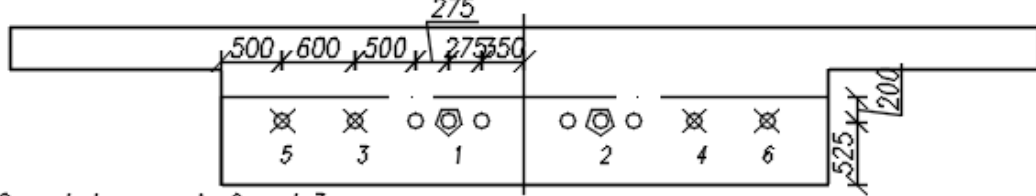

Span between axis 2 and 3

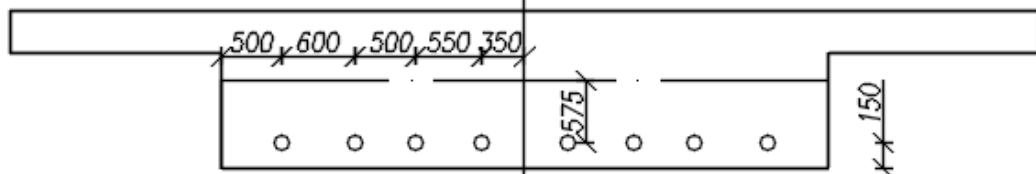

Construction joint 5,8 m right from axis 3

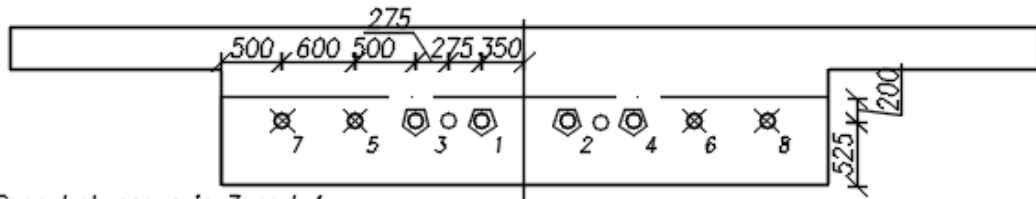

Span between axis 3 and 4

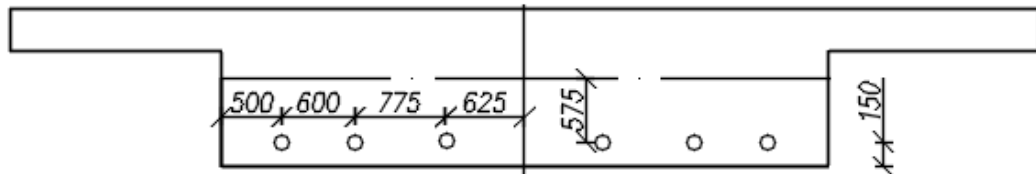

Axis 4

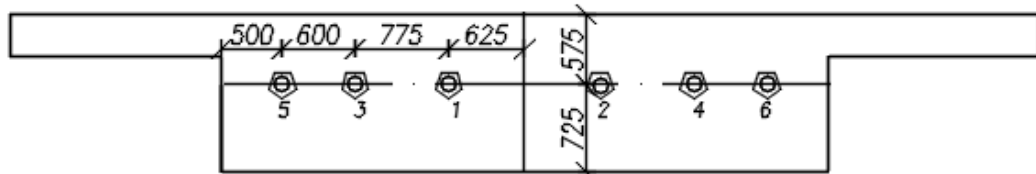

Figure 9 Position of cables and anchorages



4 Bridge

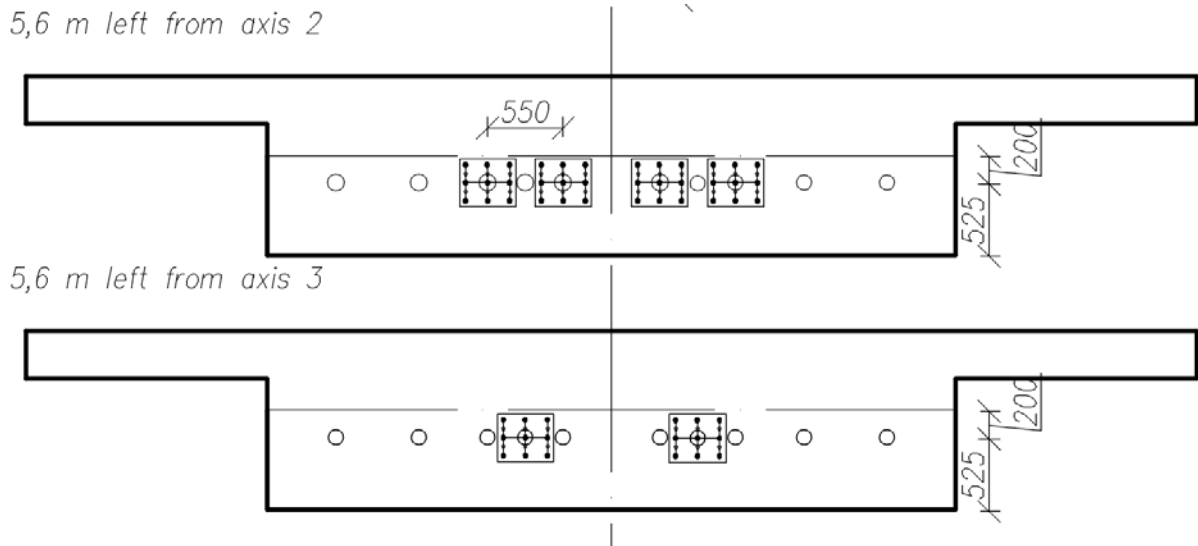

Figure 10 Position of bond head anchorages H 6815

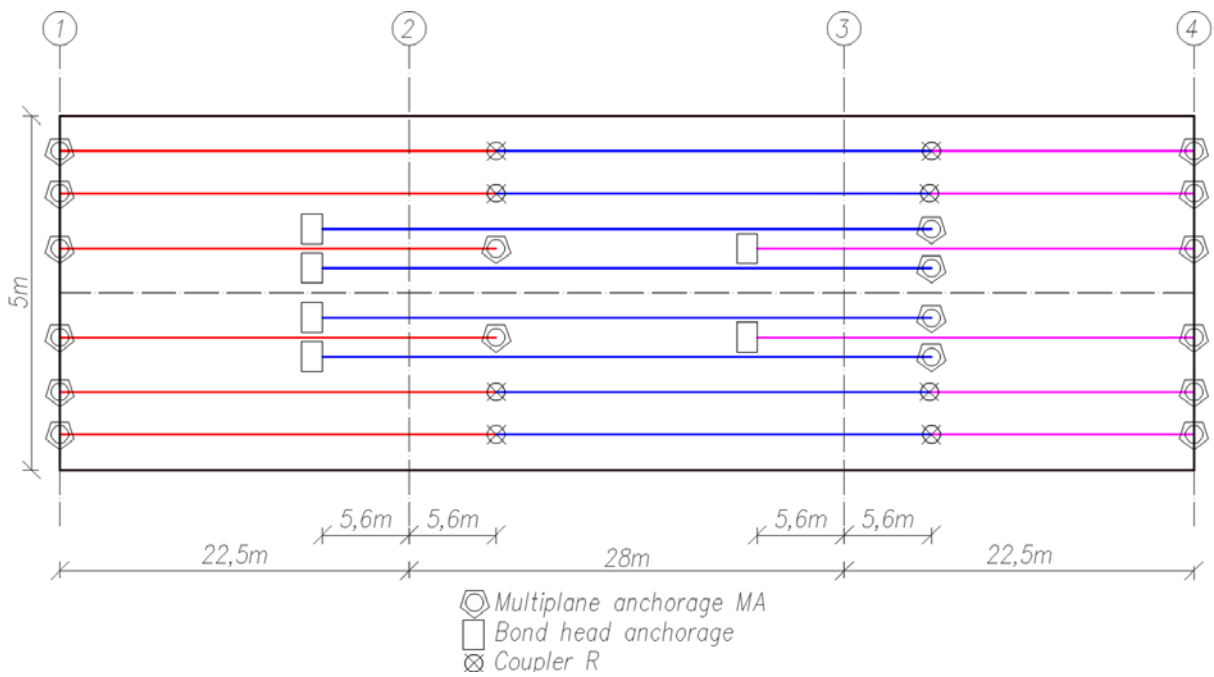

Figure 11 Horizontal position of prestressing system

## 4 Bridge

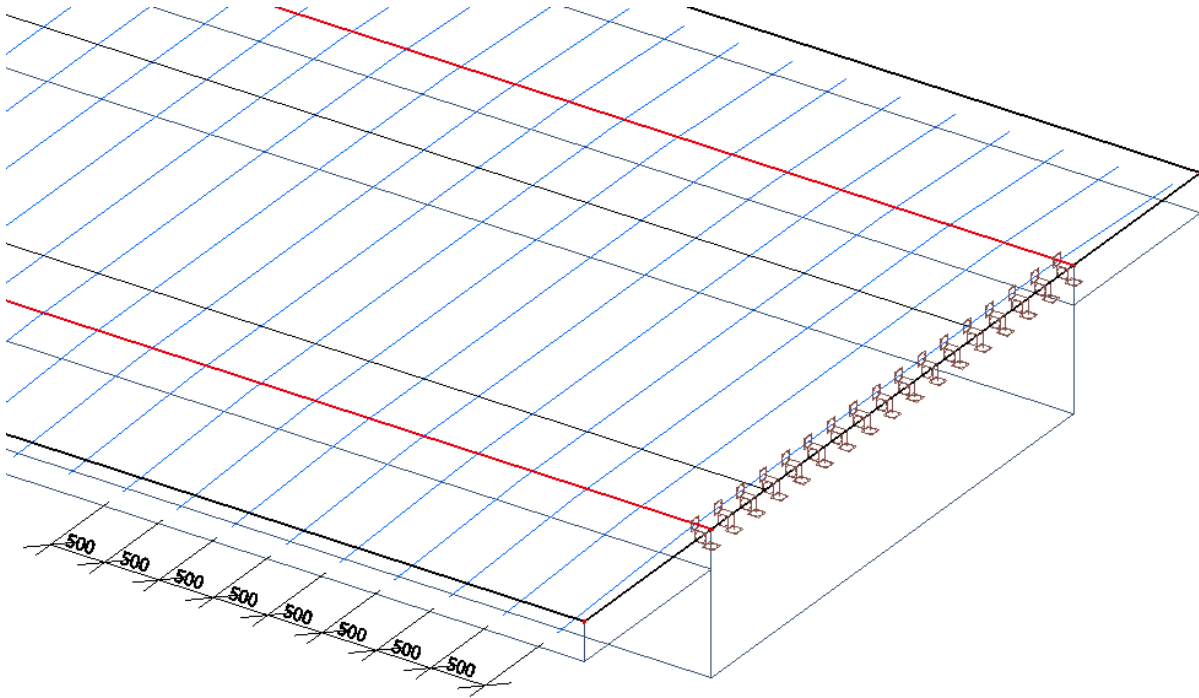

Figure 12 Horizontal position of cables in the transverse direction

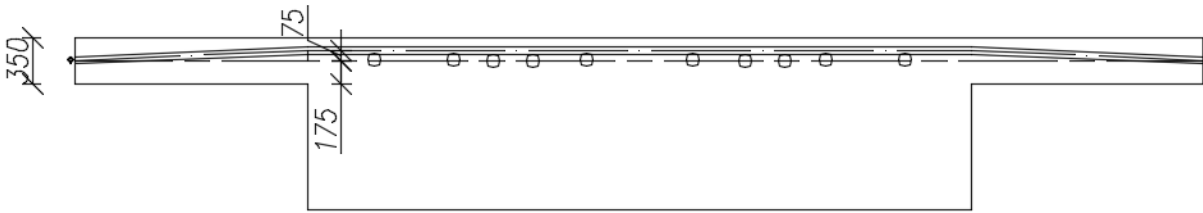
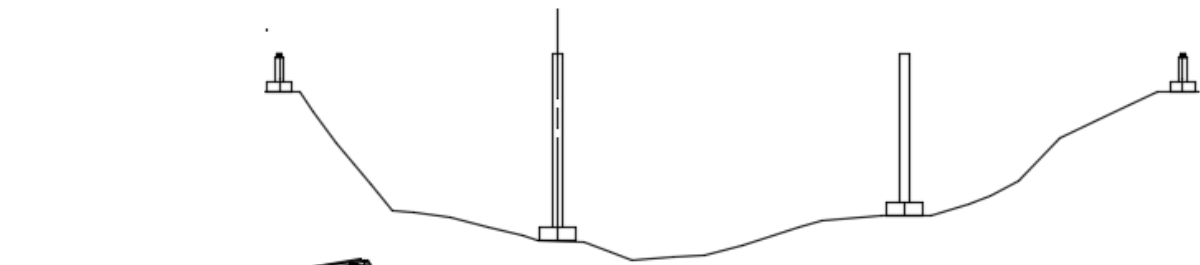

Figure 13 Position of cables in the transverse direction over supports

## 4.4. Construction stages

Proposition of the building process of the bridge is divided into 4 construction stages as shown in Figure 14 below.

*STAGE 1*



*STAGE 2*

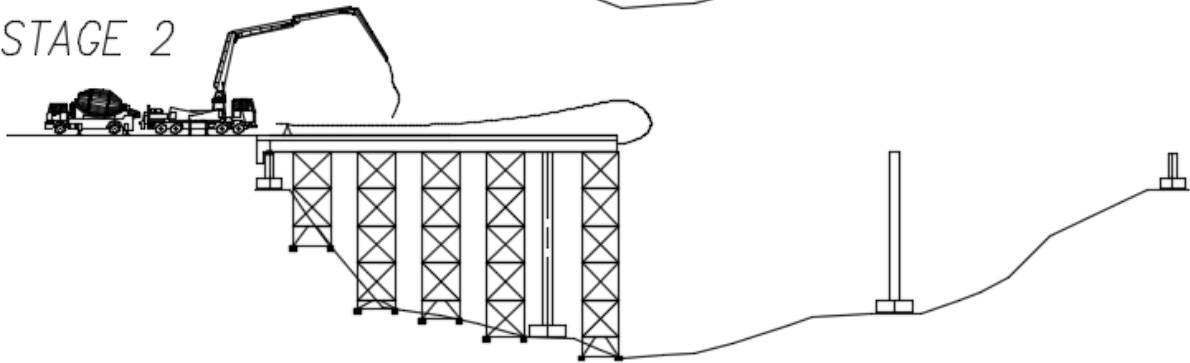

*STAGE 3*

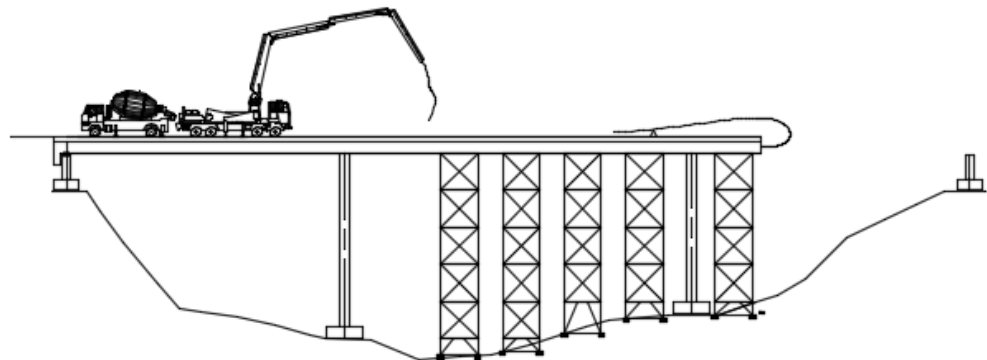

*FINAL STAGE*

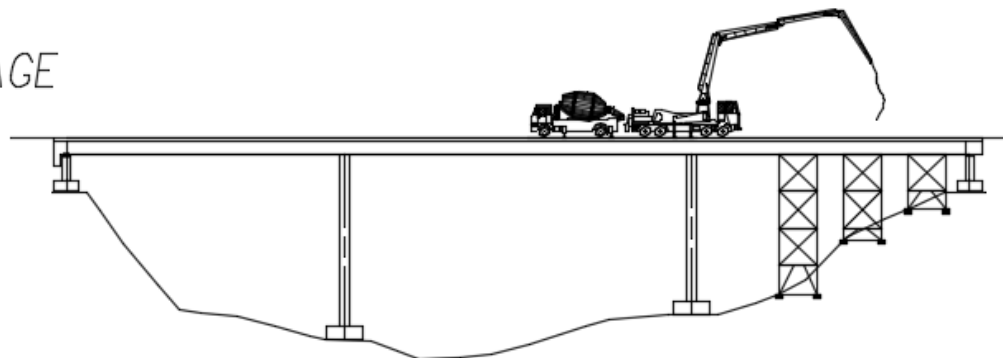

Figure 14 Construction stages

#### 4.4.1. Stage 1

In the first stage, the foundations and columns are built.

#### 4.4.2. Stage 2

In the second stage, the temporary steel support and formwork are built. Reinforcement, ducts, anchorages and couplers from the first stage are placed into position. 6 ducts are placed and 4 ducts with bond head anchorages and cables are also placed as shown on Figure 15. The concrete is casted. After the concrete reaches a compression strength of 32 MPa (7 days), 6 cables are stressed from the right side (5,6 m right from the support in axis 2) and anchored. 2 by multiplane anchorage and 4 by couplers. Grout will be filled in the ducts. The formwork and the temporary columns are disassembled and moved to stage 3

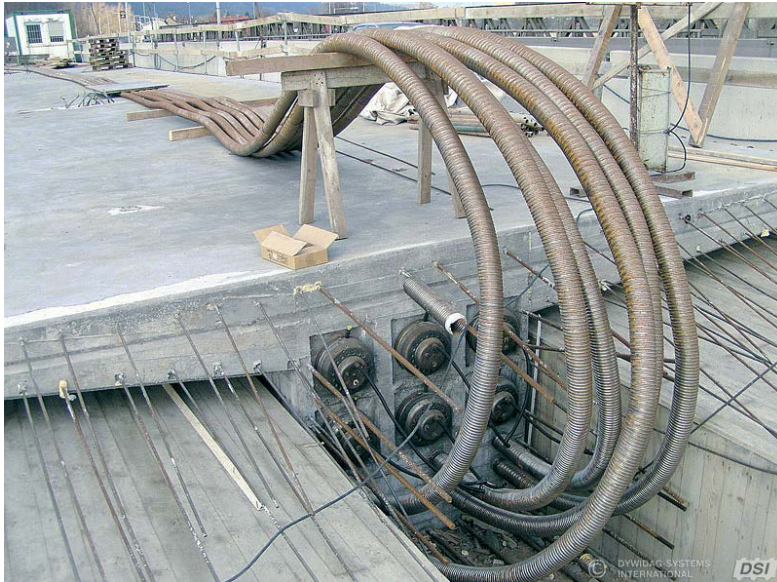

Figure 15 Example of casted duct ready for next stage [20]

#### 4.4.3. Stage 3

The formwork is placed. 4 Reinforcement, couplers of type R are placed as shown in Figure 16 and connected to their other part from stage 2. Another 2 cables with ducts and bond head anchorages are placed as shown on Figure 15, and the same procedure as in stage 2 will take a place.



Figure 16 Example of preparation of couplers R with strands. [20]

#### 4.4.4. Final stage

Reinforcement and 4 Couplers of type R are placed and connected to their other part from stage 3 and the same procedure as in stage 2 will take a place.



## 5 PRESTRESSING SYSTEM

DYWIDAG prestressing system has been chosen. The prestressing system has been recommended by advisor Håvard Johansen from Statens vegvesen. The prestressing system DYWIDAG has a complete solution for the purpose of this master's thesis.

### 5.1. Ducts

Metal ducts represent the most economical means to create a void for tensile elements. These thin-walled (0.25 - 0.60 mm) ribbed sheet metal ducts provide a fair secondary corrosion protection with excellent bond behaviour between tendon and concrete. Primary corrosion protection is provided by the alkalinity of grout and concrete.

For this master's thesis, a duct with an outer diameter of 100 mm will be used as shown in Figure 17. The minimum curvature of the duct is 7,2 m. The wobble coefficient is  $k=0,005 \text{ rad/m}$  and the friction coefficient  $\mu=0,19 \text{ rad}^{-1}$ . [8]

Tendon Type		Sheathing	
0.5"	0.6"/0.62"	I.D.	O.D.
		mm	mm
5901	6801	25	30
5902	6802	40	45
5904	6803	45	50
5905	6804	50	55
5907	6805	55	60
5909	6807	60	65
5912	6809	70	75
5915	6812	80	85
5920	6815	85	90

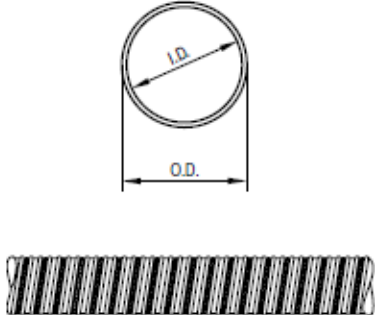

Figure 17 Corrugated Duct [14]

Thick-walled polyethylene/polypropylene (PE/PP) plastic ducts as shown in Figure 18 provide long-term secondary corrosion protection especially in aggressive environments such as waste water treatment plants, acid tanks, silos or structures exposed to de-icing salts. DYWIDAG-Systems International offers PE/PP ducts in straight lengths up to  $\approx 24$  m for all sizes, with wobble coefficient  $k=0,008 \text{ rad/m}$  and friction coefficient  $\mu=0,12 \text{ rad}^{-1}$ . [21]

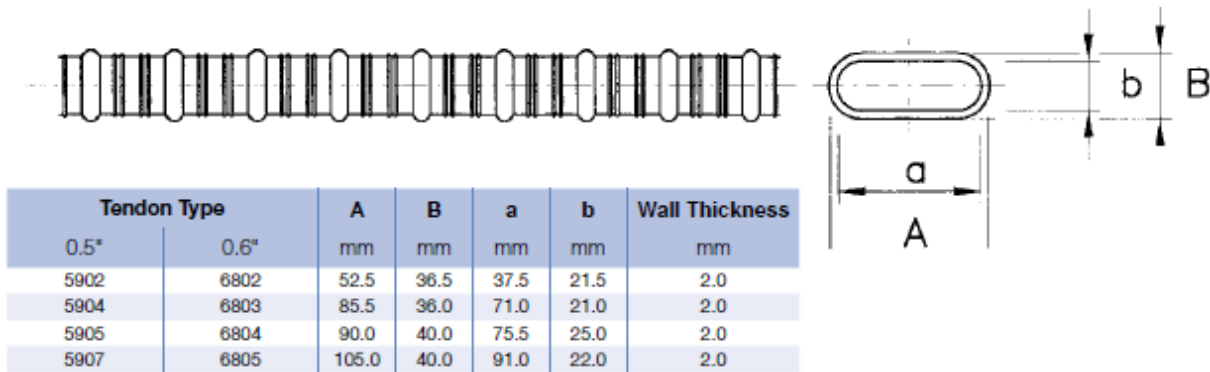

Figure 18 Flat PE/PP Duct [14]

## 5.2. Anchorages

In this master's thesis the following anchorages are used:

- Multiplane Anchorage MA
- Bond head anchorage
- Flat Multiplane Anchorage FMA

### Multiplane Anchorage MA

Two-part multiplane anchorages are primarily used for longitudinal tendons in beams and bridges. The MA anchorage can be installed with and without helix reinforcement.

A multiplane anchorage MA for 15 strands with a helix reinforcement are used in this master's thesis. They are assumed as active and passive anchorages. An active anchorage means that the anchorage will be jacked from it. Anchorage slip is set to 6 mm. A typical Multiplane Anchorage MA is shown in Figure 19 and a CAD detail of a multiplane anchorage MA for 15 strands is shown in Figure 20.



Figure 19 Multiplane Anchorage MA [14]



## 5 Prestressing system

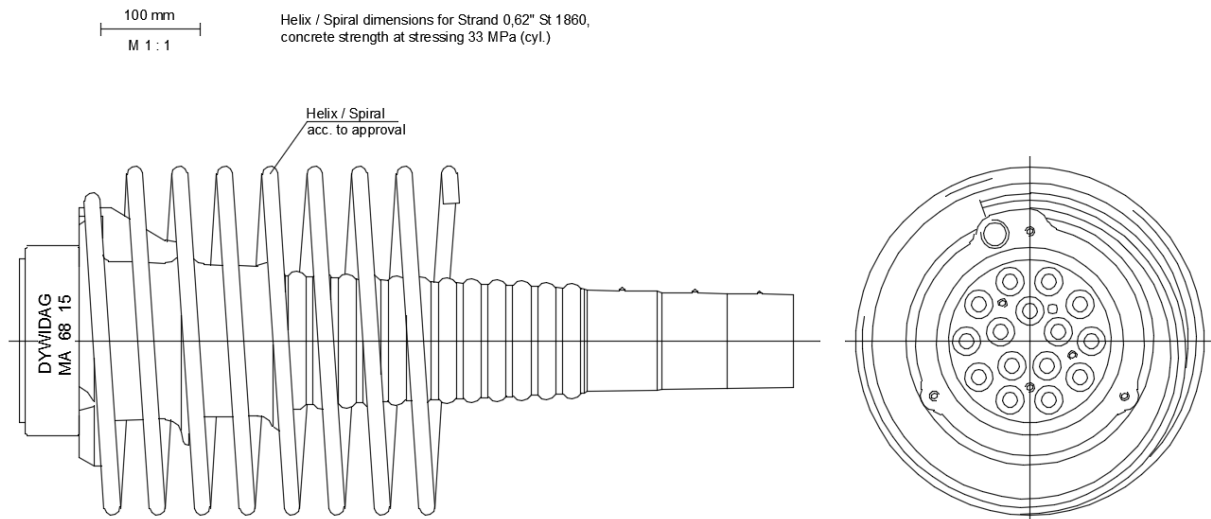

Figure 20 CAD detail of Multiplane Anchorage MA 6815

### Bond head anchorage

A bond head anchorage is primarily used with prefabricated tendons, but it is also possible to fabricate this anchorage on site. The strand wires are plastically deformed to ensure a safe load transfer up to ultimate capacity in the area of the bond head proven in static as well as in dynamic applications. Depending on the boundary conditions, either a rather flat or a bulky bond head anchorage pattern is available.

Bond head anchorages are placed into the formwork and casted afterwards.

In this master's thesis a bulky bond head anchorage pattern for 15 strands is used. The typical bond head anchorage is shown in Figure 21.

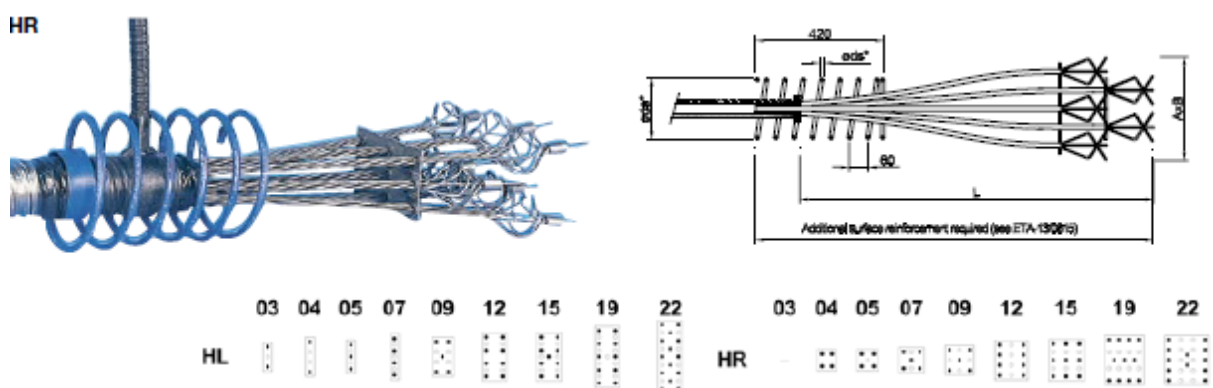

Figure 21 Bond head anchorage details and position [14]

### Flat Multiplane Anchorage FMA

The Flat Multiplane Anchorage for 2 strands are used as transverse post-tensioning of the top slab. The strands in one plane deviate into one oval duct. An example of Flat Multiplane Anchorage FMA for 5 strands is shown in Figure 22.



Figure 22 Flat Multiplane Anchorage FMA [14]

### 5.3. Coupler

Coupler R is designed to couple on to already installed and stressed tendons. The coupler consists of a multiplane anchor body and a coupler wedge plate where the strands are overlapped. The continuing strands can be installed easily and independently. An example of a typical coupler R is shown in Figure 23 and its' CAD detail in Figure 24

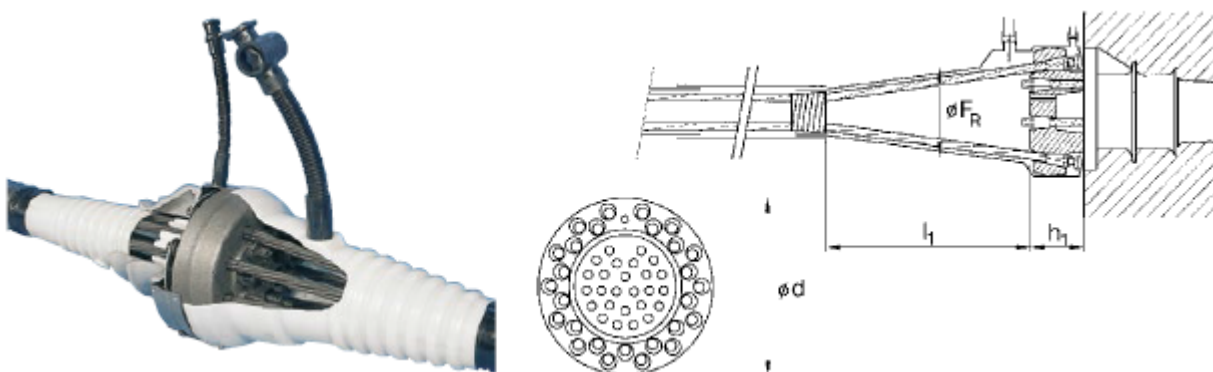

Figure 23 Coupler R [14]

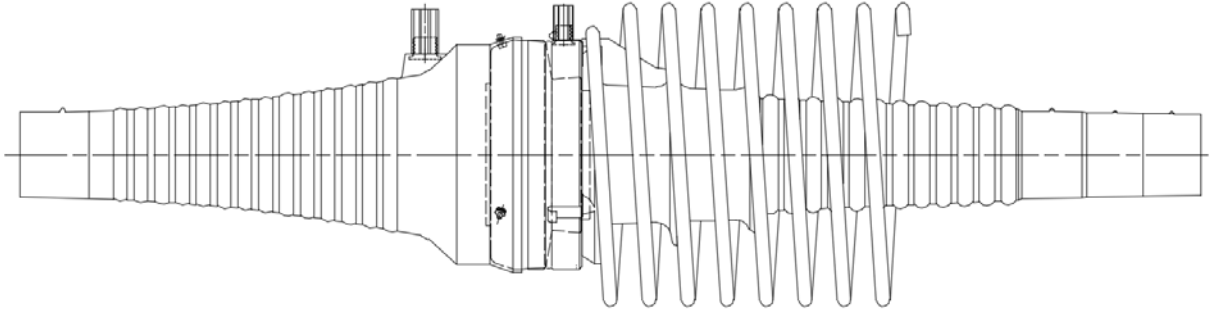

Figure 24 Coupler R CAD detail

## 5.4. Stressing

A hydraulic pump unit and a centre hole jack are used for stressing tendons. The strands pass through the jack and are anchored in the tension disk. All strands of a tendon are stressed simultaneously. Tendons are stressed from active multiplane anchorages MA or couplers R. The jack 5400 is recommended by DYWIDAG for tendons with 15-22 strands and it is shown in Figure 25



Figure 25 Jack 5400 [14]

## 5.5. Grouting

The durability of post-tensioned construction depends mainly on the success of the grouting operation. The hardened cement grout provides bond between concrete and tendon as well as primary long-term corrosion protection for the prestressing steel.

The grout is injected through the anchor body MA. The ducts are vented at the ends of the tendon by means of venting pipes or groutings caps. All grouting components are threaded for easy, fast and positive connection.



## 6 PRESTRESS LOSSES

There are several factors which cause the force in the prestressing tendons to fall from the initial force imparted by the jacking system. Some of these losses are immediate, affecting the prestress force as soon as it is transferred to the concrete member. Other losses occur gradually with time.

Friction losses only affect post-tensioned members, and vary along their length. Thus the resulting prestress force anywhere in a post-tensioned member not only varies with time but with the position considered.

In this chapter short-term and long-term losses will be explained.

### 6.1. Short-term losses

Short-term (immediate) losses occur during prestressing of tendons and transfer of prestress to concrete member.

An example of short-term losses for the cable from the 1<sup>st</sup> stage is shown in Figure 26.

The cable is jacked from right side (5,6 m right from axis 2). The blue line shows loss without anchorage slip. The red line shows final loss for the cable after anchorage slip.



Figure 26 Short-term losses for the cable from the 1<sup>st</sup> stage.

### **6.1.1. Anchorage slip**

A prestressing tendon may undergo a small contraction during the process of transferring the tensioning force from the jack to the anchorage; this is known as “anchorage draw-in” or “anchorage slip”. The exact amount of contraction depends on the type of anchorage used and is usually specified by the manufacturer of the anchorage. In the case of pretensioning, the contraction can easily be compensated by initially over-extending the tendons by a calculated amount of anchorage draw-in.

The value of anchorage slip for this master’s thesis is 6 mm (Appendix A). The slip of the wedges can be reduced by ensuring that they are pushed forward as far as possible to grip the tendons before releasing the jack.

### **6.1.2. Friction**

In post-tensioned members there is friction between the prestressing tendons and the duct walls during tensioning. The magnitude of this friction depends on the type of duct-former used and the type of tendon. There are two basic mechanisms which produce friction. One is the curvature of the tendons to achieve a desired profile, and the other is the inevitable and unintentional deviation between the centrelines of the tendons and the ducts. The friction losses depend on Wobble coefficient  $k$  and friction coefficient  $\mu$ .

## 6.2. Long-term losses

Long term (time dependent) losses occur during the service life of a structure. The rates of creep and shrinkage and of relaxation of the prestressing steel are greatest during the early ages, and decrease continuously with time (when under constant environmental conditions). Calculation of the long term losses is conducted according to EN 1992 section 5.10.6. The values of long-term losses are used for analytical model in Section 8.1.5.5

### 6.2.1. Creep

Creep is a time-dependent increase of a deformation under a sustained load. Due to creep, the prestress in tendons decreases with time. Factors affecting creep and shrinkage of concrete include: age, applied stress level, density of concrete, cement content in concrete, water-cement ratio, relative humidity and temperature.

Creep is due to sustained (permanent) loads only. Temporary loads are not considered in calculation of creep. Since the prestress may vary along the length of the member, an average value of the prestress is considered. The creep for the purpose of this master's thesis is  $\epsilon_{cc}=0,230\%$ . The complete calculation is found in Appendix H

More details about creep in Section 7.6.

### 6.2.2. Shrinkage

Shrinkage of concrete is defined as contraction due to loss of moisture. The prestress in the tendon is reduced with time due to the shrinkage of concrete.

The shrinkage of concrete is explained in details in the Section 7.7. Shrinkage strain for further work in this master's thesis is set to  $\epsilon_{cs}=0,2942\%$ . The complete calculation is found in Appendix G

### 6.2.3. Relaxation

Relaxation of steel is defined as the decrease in stress with time under constant strain. The prestress in the tendon is reduced with time due to the relaxation of steel. The relaxation depends on the type of steel, initial prestress and the temperature.

The prestressing steel in this master's thesis are in Class 2 - low relaxation

The relaxation values for use in NovaFrame (S1, S2 and T2) have been given by Statens vegvesen. The values are found in Section 8.1.5.5





## 7 LOADS

Eurocode 1: Actions on structures and its parts and N400 define different types of loads in the following manner;

- Permanent loads – self-weight, water pressure, earth pressure
- Variable loads - traffic
- Nature loads – thermal, wind, snow and seismic
- Deformation loads – prestressing, creep, shrinkage, relaxation
- Accidental loads – vehicle, ship and train collision, explosion

For the purposes of this master's thesis only the following loads are considered:

- Self-weight
- Traffic
- Thermal, wind
- Prestressing, creep, shrinkage, relaxation

They are further explained in the sections below.

### 7.1. Self-weight

The area of the cross section is  $7,725 \text{ m}^2$ . The weight of the concrete is assumed to be  $25 \text{ kN/m}^3$ .

### 7.2. Self-weight – other

Super self-weight of  $40 \text{ kN/m}$  (restraint systems, kerb, edge beams, tarmac) is given by SVV.

### 7.3. Traffic loads

From EN 1991-2 the following is defined about loads: Loads due to traffic give rise to vertical and horizontal, static and dynamic forces. Loads are described by load models (LM). Load models which can act at the same time constitute a group of loads (gr).

This applies to bridges of lengths less than  $200 \text{ m}$ , which is the case of this master's thesis.

#### 7.3.1. Notional lanes

The carriageway is defined as the part of the roadway surface sustained by a single structure. The carriageway is divided into notional lanes, generally  $3 \text{ m}$  wide, and into

a remaining area. The carriageway is measured between the inner limits of vehicle restraint systems.

The carriageway width in this master's thesis is 8,5 m. So there will be 2 notional lanes 3 m width and 1 remaining area with width 2,5 m. For numbering of carriageway lanes see Figure 27

### 7.3.2. VERTICAL FORCES

Four different load models are described:

- Load model 1 - composed by concentrated and uniformly distributed loads, which cover most of the effects of the traffic of lorries and cars, to be used for global and local verifications.
- Load model 2 - composed by a single axle load on specific tire contact areas, which cover traffic effects on short structural members;
- Load model 3 - special vehicles, representing abnormal vehicles not complying with national regulations on weight and dimension of vehicles; which should be considered only when requested in a transient design situation. The geometry and the axle loads of the special vehicles to be considered will be assigned by the bridge owner.
- Load model 4 - a crowd loading.

Only load models LM1 and LM2 are considered in this master's thesis. Positions which will give maximum and minimum shear force, bending moment and torsional moment are calculated automatically by program NovaFrame.

### 7.3.3. Load model LM1

Load model 1 consists of two subsystems, one load group with double axels and one load group with uniformly distributed load. (See Figure 27 and Figure 28)

The tandem system travels in the direction of the longitudinal axis of the bridge, centrally along the axis of the notional lane.

The contact surfaces of the wheel, if not otherwise specified is a square of sides 40 x 40 cm (see Figure 27 and Figure 30).

Table 7.1 LM1 – characteristic values [8]

Location	$Q_{ik}$ [kN]	$q_{ik}$ [kN/m <sup>2</sup> ]	$\alpha_{Qi}$	$\alpha_{qi}$	Tandem system	UDL
					TS	system
					$Q_{ik} * \alpha_{Qi}$ [kN]	$q_{ik} * \alpha_{qi}$ [kN/m <sup>2</sup> ]
Lane number 1	300	9,0	1,0	0,6	<b>300</b>	<b>5,4</b>
Lane number 2	200	2,5	1,0	1,0	<b>200</b>	<b>2,5</b>
Lane number 3	-	2,5	-	1,0	<b>0</b>	<b>2,5</b>

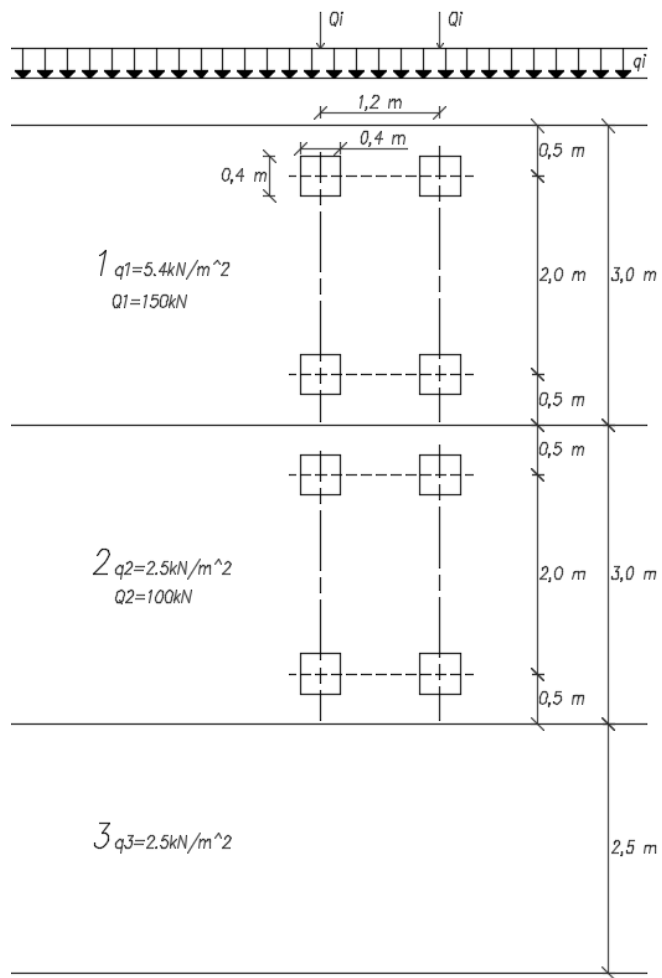

Figure 27 Application of LM1 and positions of the carriageway lanes

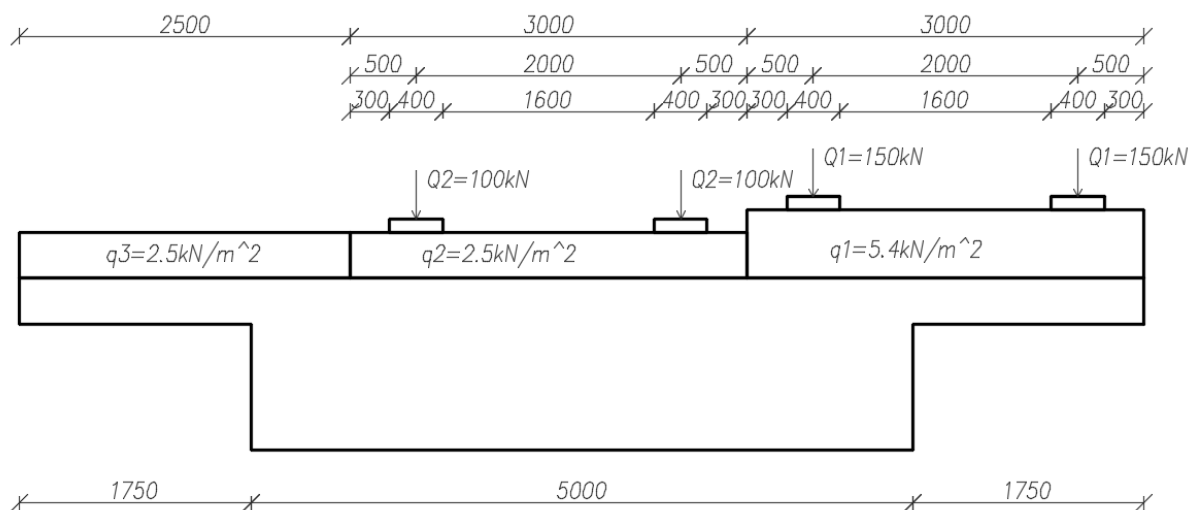

Figure 28 Position of LM1

### 7.3.4. Load model LM2

LM2 is a model constituted by a single axle load.  $\beta_Q=1,0$ ,  $Q_{ak}=400$  kN

Load model 2 considers traveling in the direction of the longitudinal axis of the bridge and should be applied in any location on the carriageway. The contact surfaces of the wheel, if not otherwise specified, is a rectangle of sides 35 x 60 cm (see Figure 29 and Figure 30).

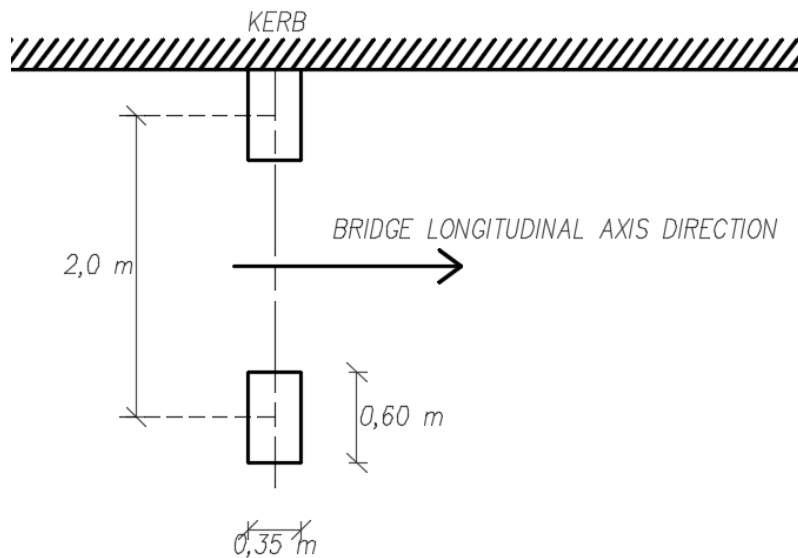

Figure 29 Position of LM2 – top view

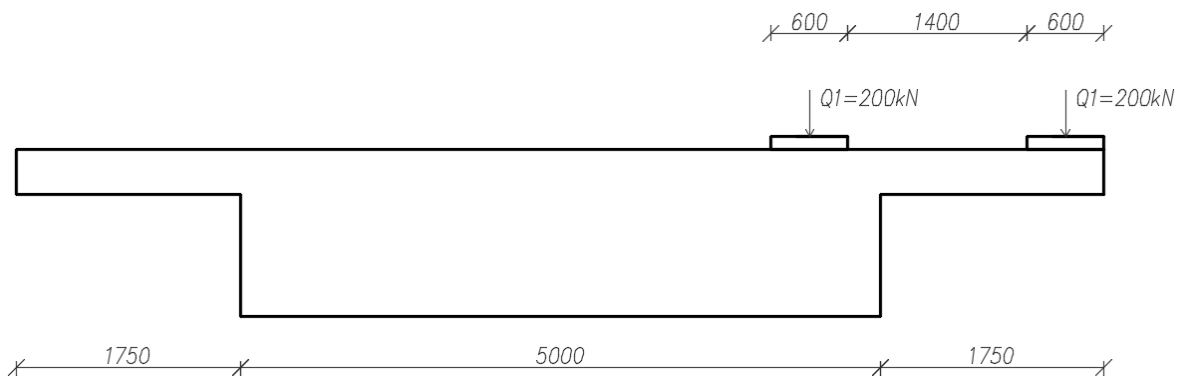

Figure 30 Position of LM2

### 7.3.5. Horizontal forces

Horizontal loads on bridges come from vehicles breaking, accelerating or turning on the bridge. Breaking loads are calculated as a part of the total vertical loads acting on a traffic lane. Acceleration loads are defined as the breaking loads acting in opposite direction, which practically means that the load can have both positive and negative sign.

The braking or acceleration force, denoted by  $Q_{lk}$ , is taken as a longitudinal force acting at finished carriageway level.

The characteristic values of  $Q_{lk}$  should be calculated as a fraction of the total maximum vertical load corresponding to the LM1 likely to be applied on notional lane number 1, as follows:

$$Q_{lk} = 0.6 \cdot \alpha_{Q1} \cdot (2 \cdot Q_{1k}) + 0.10 \cdot \alpha_{q1} \cdot q_{1k} \cdot w_1 \cdot L$$

Where  $w_1$  is the width of the lane and  $L$  the length of the loaded zone.

This force, that includes dynamic magnification, should be considered located along the axis of any lane. The upper limit is 900 kN.

The total braking or acceleration force  $Q_{lk} = 481,5$  kN (or 6,42 kN/m.)

Where relevant, lateral forces from skew braking or skidding should be taken into account. A transverse braking force  $Q_{trk}$ , equal to 25% of the longitudinal braking or acceleration force  $Q_{lk}$ , should be considered to act simultaneously with  $Q_{lk}$ .

The total lateral force  $Q_{trk} = 120,4$  kN (or 1,61 kN/m.)

### 7.3.6. Groups of traffic loads

For the purpose of this master's thesis, only groups of load gr1a/b and gr2 will be considered. The Groups gr1a/b use only vertical forces from load models and gr2 consist of vertical and horizontal forces from load model 1.

For more details see Table 7.2.

Table 7.2 Assessment of characteristic values of multi-component action [2]

Load type		CARRIAGEWAY					FOOTWAYS AND CYCLE TRACKS	
		Vertical forces			Horizontal forces		Vertical forces only	
Reference		4.3.2	4.3.3	4.3.4	4.3.5	4.4.1	4.4.2	5.3.2-(1)
Load system		LM1 (TS and UDL systems)	LM2 (Single axle)	LM3 (Special vehicles)	LM4 (Crowd loading)	Braking and acceleration forces	Centrifugal and transverse forces	Uniformly Distributed load
Groups of Loads	gr1a	Characteristic values				<sup>a</sup>	<sup>a</sup>	Combination value <sup>b</sup>
	gr1b		Characteristic value					
	gr2	Frequent values <sup>b</sup>				Characteristic value	Characteristic value	
	gr3 <sup>d</sup>							Characteristic value <sup>c</sup>
	Gr4				Characteristic value			Characteristic value <sup>b</sup>
	Gr5	See annex A		Characteristic value				
Dominant component action (designated as component associated with the group)								

## 7.4. Wind

Wind load calculation is calculated according to EN 1991-1-4 and N400. In publication N400, bridges are divided into 3 wind classes. This bridge is mentioned in the example for wind class 1 so there is no need for dynamic calculation. In the ULS and SLS combinations there is wind combined with traffic and without traffic. As mentioned before, the bridge will be built in the Trondheim municipality<sup>11</sup>. The complete calculation of wind load is found in Appendix F

The starting point for the determination of the wind velocity is the map of fundamental basic wind velocity given in EN 1991-1-4, Table NA.4 (901.1). The map is based on a 10-minute mean velocity.

Table 7.3 Information for wind load calculation

<b>Fundamental value of the basic wind velocity</b>	$V_{b,0}$	26	m/s
<b>Directional factor</b>	$C_{dir}$	1,0	
<b>Seasonal factor</b>	$C_{season}$	1,0	
<b>Altitude factor</b>	$C_{alt}$	1,0	
<b>Probability factor</b>	$C_{prob}$	1,0	
<b>Orography factor</b>	$C_o$	1,0	
<b>Height above ground</b>	$z$	14,0	m
<b>Turbulence factor</b>	$k_I$	1,0	
<b>Terrain category</b>		II	
<b>Total bridge deck width</b>		9,5	m

One of the main parameters in the determination of wind actions on structures is the characteristic peak velocity pressure denoted  $q_p$ . This parameter is the characteristic pressure due to the wind velocity of the undisturbed wind field. The peak wind velocity accounts for the mean wind velocity and a turbulence component.  $q_p$  is influenced by the regional wind climate, local factors (e.g. terrain roughness and orography/terrain topography), terrain categories and the height above terrain.

The terrain around the bridge is defined in terrain category II - an area with low vegetation such as grass and isolated obstacles (trees, buildings) with separations of at least 20 obstacle heights

The basic wind velocity  $v_b$  is:

$$v_b = c_{dir} * c_{season} * c_{alt} * c_{prob} * v_{b,0} = 26 \text{ m/s}$$

Mean wind velocity

The basic wind velocity pressure has to be transformed into the value at the reference height of the considered structure. The wind velocity at a relevant height ( $z$ ) and the gustiness of the wind depend on the terrain roughness. The roughness factor ( $c_r(z)$ ) describing the variation of the wind speed with height has to be determined in order to obtain the mean wind speed  $v_m(z)$  at the relevant height  $z$

$$v_m(z) = c_r(z) * c_0(z) * v_b = 28,17 \text{ m/s}$$

Wind turbulence

The turbulence intensity  $I_v(z)$  at height  $z$  is defined as the standard deviation of the turbulence divided by the mean wind velocity. The turbulent component of wind velocity has a mean value of 0 and a standard deviation  $I_v$ .

$$I_v(z) = \frac{k_t}{c_0 * \ln\left(\frac{z}{z_0}\right)} = 0.175$$

Peak velocity pressure

Includes mean and short-term velocity fluctuations

$$q_p(z) = 1105 \text{ Pa}$$

Wind actions on the bridge

Wind actions on the bridge produce forces in the x, y and z directions. Force coefficients for parapets and gantries on the bridge are considered. The reference area  $A_{ref,x}$  for a bridge with an open parapet on both sides add 0,6 m to the depth of the girder. The reference area in z-direction  $A_{ref,z}$  is equal to the width of carriageways and 1 meter in y-direction.

$$\text{Force in x-direction } F_{wx} = \frac{1}{2} * \rho * (v_b)^2 * C * A_{ref,x}$$

Force in y-direction is 25% of  $F_{wx}$

Force in z-direction  $F_{wz} = \frac{1}{2} \cdot \rho \cdot (v_b)^2 \cdot C \cdot A_{ref,z}$

The force is assumed to act with an eccentricity of  $e = b/4$  from the centre of the deck

Wind actions on the bridge with traffic

Where road traffic is considered to be simultaneous with the wind, a height of 2 meters from the level of the carriageway is added to  $A_{ref,x}$ . and the wind speed is assumed  $35 \text{ m/s}$ .

Table 7.4 Summary of wind load forces

	$F_{wx}$ [kN/m]	$F_{wy}$ [kN/m]	$F_{wz}$ [kN/m]
<b>With traffic</b>	2,890	0,722	9,449
<b>Without traffic</b>	4,043	1.011	6,543

## 7.5. Temperature

The values of thermal actions, the maximum and minimum shade air temperatures  $T_{max}$  and  $T_{min}$  are given by SVV and are characteristic values. The characteristic values of thermal actions given in EN 1991-1-5, are values with a mean return period of 50 years.

According to EN 1991-1-5 chapter 6.1.1, the bridge is Type 3 (concrete deck). Values of thermal action are assessed by the uniform temperature component and the temperature difference of components.

Characteristic values of thermal actions

$T_{max} = 34 \text{ } ^\circ\text{C}$  maximum shade air temperature

$T_{min} = -28 \text{ } ^\circ\text{C}$  minimum shade air temperature

### Uniform bridge temperature component

$T_{e,max}$  maximum uniform bridge temperature component

$T_{e,max} = T_{max} - 3 \text{ } ^\circ\text{C} = 31 \text{ } ^\circ\text{C}$

$T_{e,min}$  minimum uniform bridge temperature component

$T_{e,min} = T_{min} + 8 \text{ } ^\circ\text{C} = -20 \text{ } ^\circ\text{C}$



### Range of uniform bridge temperature component

$T_0$  initial temperature when structural element is restrained EN 1991-1-5 section NA.A.1(3)

$$T_0 = 10 \text{ } ^\circ\text{C}$$

$\Delta T_{N,exp}$  maximum expansion range of uniform bridge temperature component

$$\Delta T_{N,exp} = T_{e,max} - T_0 = 31 \text{ } ^\circ\text{C} - 10 \text{ } ^\circ\text{C} = 21 \text{ } ^\circ\text{C}$$

$\Delta T_{N,con}$  maximum contraction range of uniform bridge temperature component

$$\Delta T_{N,con} = T_0 - T_{e,min} = 10 \text{ } ^\circ\text{C} + 20 \text{ } ^\circ\text{C} = 30 \text{ } ^\circ\text{C}$$

### Vertical linear component

$\Delta T_{M,heat}$  linear temperature difference component (heating) EN 1991-1-5 Table 6.1

$$\Delta T_{M,heat} = 15 \text{ } ^\circ\text{C}$$

$\Delta T_{M,cool}$  linear temperature difference component (cooling) EN 1991-1-5 Table 6.1

$$\Delta T_{M,cool} = 8 \text{ } ^\circ\text{C}$$

It is assumed that the thickness of the surface of the bridge is 50 mm, which gives a  $k_{sur}$  equal to 1,0 and the non-linear component can be neglected.

### Simultaneity of uniform and temperature difference components

If it is necessary to take into account both temperature difference and the maximum range of uniform bridge component assuming simultaneity

$$\Delta T_{M,heat} \text{ (or } \Delta T_{M,cool}) + \omega_N * \Delta T_{N,exp} \text{ (or } \Delta T_{N,con})$$

$$\omega_M * \Delta T_{M,heat} \text{ (or } \Delta T_{M,cool}) + \Delta T_{N,exp} \text{ (or } \Delta T_{N,con})$$

$$\omega_N = 0,35$$

$$\omega_M = 0,75$$

### Load combinations for thermal actions:

- $\Delta T_{M,heat} + \omega_N * \Delta T_{N,exp} = 15 \text{ } ^\circ\text{C} + 0,35 * 21 \text{ } ^\circ\text{C}$
- $\Delta T_{M,cool} + \omega_N * \Delta T_{N,con} = 8 \text{ } ^\circ\text{C} + 0,35 * 30 \text{ } ^\circ\text{C}$
- $\omega_N * \Delta T_{M,heat} + \Delta T_{N,exp} = 0,75 * 15 \text{ } ^\circ\text{C} + 21 \text{ } ^\circ\text{C}$
- $\omega_N * \Delta T_{M,cool} + \Delta T_{N,con} = 0,75 * 8 \text{ } ^\circ\text{C} + 30 \text{ } ^\circ\text{C}$

## 7.6. Creep

Creep is time-dependent deformation under constant load. Creep affects long term deflection and loss of prestress force. Creep depends on the ambient humidity, the dimension of the cross-section and the composition of the concrete (cement type). Creep is influenced by the maturity of the concrete when the load is first applied and depend on the duration and magnitude of the loading.

The creep coefficient  $\varphi(t, t_0)$  is related to the tangent modulus  $E_c$

When the concrete is subjected to a compressive stress lower than  $0,45 f_{ck}$  creep linearity should be considered.

The creep deformation of concrete is given by:

$$\varepsilon_{cc}(\infty, t_0) = \varphi(\infty, t_0) * \sigma_c / E_c$$

Creep of the concrete is the reason for requiring a minimum characteristic compression strength 32 MPa at the time of prestressing. The concrete will have a characteristic compression strength  $f_{ck}$  33 MPa, 7 days after casting. According to N400, the relative humidity of the ambient environment is 70%.

Creep will be calculated by using an effective modulus of elasticity for concrete according to EN 1992 section 7.4.3 (7.20) as shown below

$$E_{c,eff} = \frac{E_{cm}}{1 + \varphi(\infty, t_0)}$$

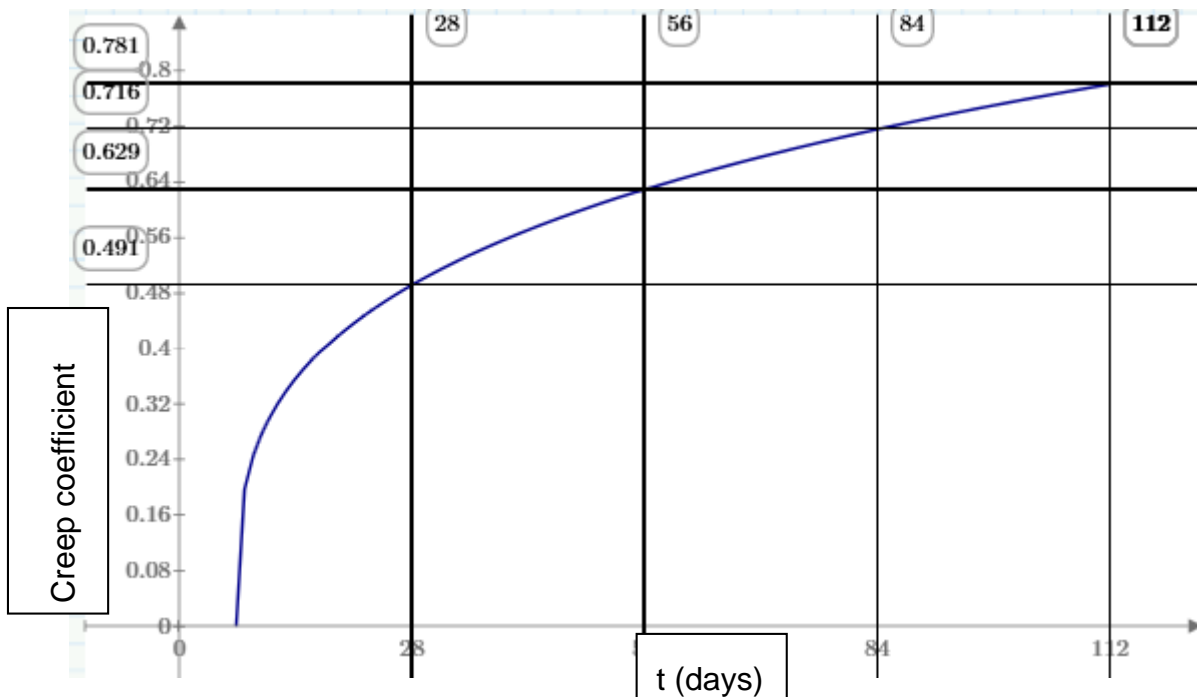

Figure 31 Creep coefficient 0 – 112 days

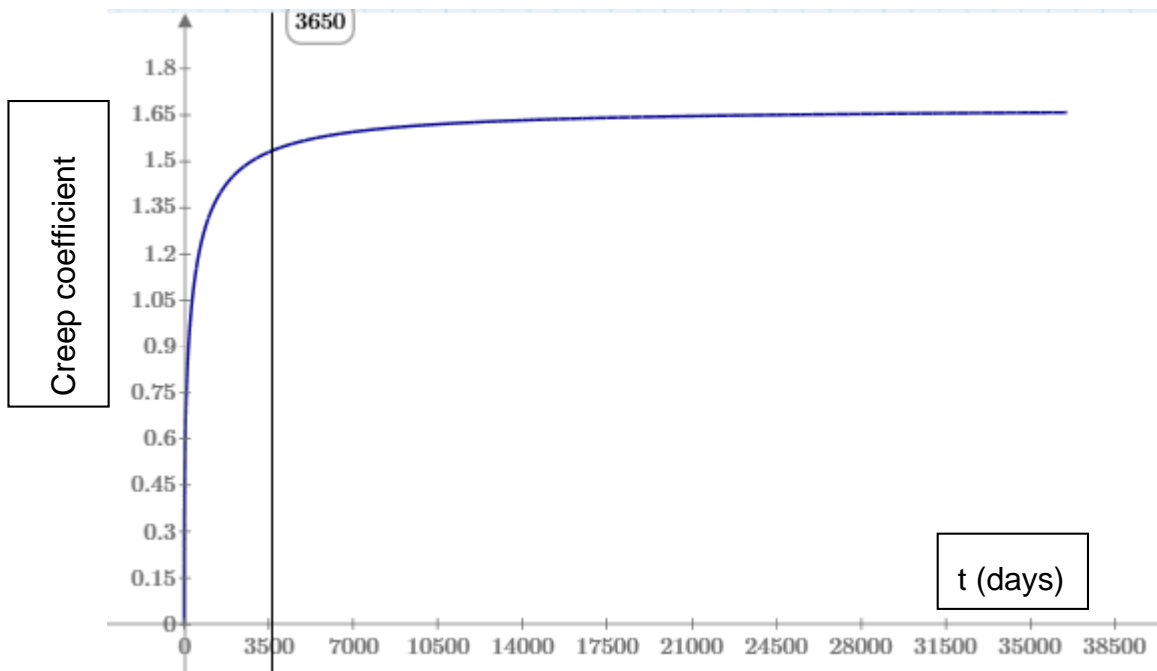

Figure 32 Creep coefficient 0 – 36500 days

For the three different construction stages involving casting of concrete, there will be concrete at various ages and thus creep coefficients. Figure 31 and Figure 32 show that the creep coefficient varies with time and grows fast during the first days. After around 10 years (3650 days), the creep coefficient does not develop so fast and it is almost constant. The calculation of the creep coefficient is found in appendix G and the results are shown in Table 7.5

Table 7.5 Creep coefficient for different construction stages

	Stage 2 after 28 days	Stage 3 after 56 days	Final stage after 84 days	Final stage after 112 days	Final stage after 36500 days
Concrete part 1	0,491	0,629	0,716	0,781	1,659
Concrete part 2		0,491	0,629	0,716	1,659
Concrete part 3			0,491	0,629	1,659

## 7.7. Shrinkage

Shrinkage is also a time-dependent deformation. Concrete contains water, and as the surplus water that has not been used to hydrate the cement evaporates, the concrete member shrinks. The amount of shrinkage is dependent on the environmental conditions surrounding the concrete, and is independent of the external load on the member. Shrinkage of concrete varies with time

The total shrinkage strain is composed of two components, the drying shrinkage strain  $\epsilon_{cd}$  and the autogenous shrinkage strain  $\epsilon_{ca}$ . The drying shrinkage strain develops slowly, since it is a function of the migration of the water through the hardened concrete. The autogenous shrinkage strain develops during hardening of the concrete: the major part therefore develops in the early days after casting. Autogenous shrinkage is a linear function of the concrete strength. It should be considered specifically when new concrete is cast against hardened concrete.

The calculation of the shrinkage strain is according to EN 1992 section 3.4.4(6) and Annex B. The results of shrinkage strains are shown below:

Total shrinkage strain  $\epsilon_{cs} = \epsilon_{cd} + \epsilon_{ca}$

$$\epsilon_{cd} = 2,067 \cdot 10^{-4}$$

$$\epsilon_{ca} = 0,875 \cdot 10^{-4}$$

$$\epsilon_{cs} = \epsilon_{cd} + \epsilon_{ca} = 2,942 \cdot 10^{-4}$$

For the purpose of this master's thesis, only shrinkage strain after 100 years will be taken into account.

Complete calculation in Appendix G

## 7.8. Load combination

Load combination is described in EN 1990.

More details are described in EN 1990A where rules and methods are given for establishing combinations of actions for serviceability and ultimate limit state verifications (except fatigue verifications) with the recommended design values of permanent, variable and accidental actions and  $\psi$  factors to be used in the design of road bridges, footbridges and railway bridges.

Snow loads need not be combined with Load Models 1 and 2 or with the associated groups of loads gr1a and gr1b.

Table 7.6 shows the recommended values of  $\psi$  factor for road bridges, this factor is used for limit states combinations.

Table 7.6 Recommended values of  $\psi$  factors for road bridges [2]

Action	Symbol	$\psi_0$	$\psi_1$	$\psi_2^{5)}$	$\psi_{1,infq}^{1)}$	
Traffic loads (se NS-EN 1991-2, tabell 4.4)	gr1a	TS	0,7 <sup>3)</sup>	0,7	0,2/0,5	0,8
	(LM1 + horizontale loads + pedestrian or cycle-track loads)	UDL	0,7 <sup>3)</sup>	0,7	0,2/0,5	0,8
		Horizontal forces	0,7 <sup>3)</sup>	0,7	0,2/0,5	0,8
		Pedestrian+cycle-track loads <sup>2)</sup>	0,7 <sup>3)</sup>	0,7	0,2/0,5	0,8
	gr1b (Single axle)		0,7 <sup>3)</sup>	0,7	0,2/0,5	0,8
	gr2 (Horizontal forces)		0,7 <sup>3)</sup>	0,7	0,2/0,5	0,8
	gr3 (Pedestrian loads)		0,7 <sup>3)</sup>	0,7	0,2/0,5	0,8
	gr4 (LM4 – Crowd loading)		0,7 <sup>3)</sup>	0,7	0,2/0,5	0,8
gr5 (LM3 – Special vehicles)		-	-	-	-	
Wind forces	$F_{wk}$ - Persistent design situations		0,7	0,6	0/0,5	0,8
	$F_{wk}$ - Execution		0,8	-	-	-
	$F_w^*$		0,7	0,6	0/0,5	0,8
Thermal actions <sup>4)</sup>	$T_k$		0,7	0,6	0/0,5	0,8

### 7.8.1. Ultimate limit state (ULS)

The ultimate limit states are associated with collapse and other similar forms of structural failure. The ultimate limit states concern the safety of people and/or the safety of the structure

The term 'ultimate limit state of strength' has been used to refer to the ultimate limit state of failure induced by limited strength of a material as dealt with in the design Eurocodes EN 1992 to EN 1999.

- **EQU**: Loss of static equilibrium of the structure or any part of it considered as a rigid body, where:
  - minor variations in the value or the spatial distribution of actions from a single source are significant, and
  - the strengths of construction materials or ground are generally not governing;
- **STR**: Internal failure or excessive deformation of the structure or structural members, including footings, piles, basement walls, etc., where the strength of construction materials in the structure governs;
- **GEO**: Failure or excessive deformation of the ground where the strength of soil or rock are significant in providing resistance;
- **FAT**: Fatigue failure of the structure or structural members.

For the purpose of this master's thesis, only Limit states of type STR is considered

Limit states of type STR corresponding to a failure by lack of structural resistance or excessive deformation are easier to comprehend. Nevertheless, a possible structural failure may be the consequence of a series of undesirable events that give rise to a hazard scenario. It is reasonable for all design situations idealising the consequences of a particular hazard scenario to be checked with the set of  $\gamma$  factors associated with the first of the events which give rise to the hazard scenario. Therefore, the designer should select the appropriate limit state corresponding to the first event which will govern the combinations of actions.

## 7 Loads

For the STR limit state - less favourable of the two following expressions is assumed:

$$\sum_{j \geq 1} \gamma_{G,j} G_{k,j} + \gamma_P P + \gamma_{Q,1} \psi_{Q,1} Q_{k,1} + \sum_{i > 1} \gamma_{Q,i} \psi_{Q,i} Q_{k,i} \quad (6.10a)$$

$$\sum_{j \geq 1} \xi_j \gamma_{G,j} G_{k,j} + \gamma_P P + \gamma_{Q,1} Q_{k,1} + \sum_{i > 1} \gamma_{Q,i} \psi_{Q,i} Q_{k,i} \quad (6.10b)$$

Where  $\xi$  is a reduction factor for unfavourable permanent actions and '+' denotes 'to be combined with',  $\sum$  denotes "the combined effect of " and P represents action due to prestressing. The value of  $\psi$ , factor for actions, is given by Table 7.5.

$\gamma_{Gj,sup}/\gamma_{G,inf}$	= 1,35/1,00 for unfavourable/ favourable permanent actions
$\xi$	= 0,89 for permanent actions
$\gamma_Q$	= 1,60 for wind load where unfavourable (0 where favourable)
$\gamma_Q$	= 1,20 for temperature load where unfavourable (0 where favourable)
$\gamma_Q$	= 1,35 for traffic where unfavourable (0 where favourable)
$\gamma_Q$	= 1,50 for variable actions where unfavourable (0 where favourable)
$\gamma_P$	= 0,9/1,1 depends what is unfavourable (EN 1992, NA.2.4.2.2)
$\psi$	= see Table 7.6

### 7.8.2. Serviceability limit state (SLS)

Serviceability limit states correspond to conditions of normal use (deflections, vibration, cracks, etc.). In particular, they concern the functioning of the structure or structural members, comfort of people and appearance of the construction works.

Three categories of combinations of actions are proposed in EN 1990: characteristic, frequent and quasi-permanent.

- The characteristic combination is expressed as follows:

$$\sum_{j \geq 1} G_{k,j} + P + Q_{k,1} + \sum_{i > 1} \psi_{0,i} Q_{k,i} \quad (6.14b)$$

This characteristic combination of actions is built on the same pattern as the fundamental combination of actions for STR/GEO ultimate limit states: all  $\gamma$  factors are generally equal to 1, and this is an aspect of the semi-probabilistic format of structural verifications.

- The frequent combination

$$\sum_{j \geq 1} G_{k,j} + P + \psi_{1,1} Q_{k,1} + \sum_{i > 1} \psi_{2,i} Q_{k,i} \quad (6.15b)$$

- The quasi-permanent combination

$$\sum_{j \geq 1} G_{k,j} + P + \sum_{i > 1} \psi_{2,i} Q_{k,i} \quad (6.16b)$$

The quasi-permanent combination is used for the assessment of long-term effects (e.g. effects due to creep and shrinkage in concrete structures)



### 7.8.3. Summary of load combinations

The summary of load combinations for the Ultimate limit state is shown in Table 7.7 and the summary of load combinations for the Serviceability limit state is shown in Table 7.8 to Table 7.10. All combination show actual load factors.

Table 7.7 ULS load combination

ULS – STR – set B								
	6.10a	6.10b	6.10a	6.10b	6.10a	6.10b	6.10b	6.10b
	gr1a	gr1a	gr1b	gr1b	wind without traffic temp	wind without traffic temp	Temp wind with traffic	Temp wind without traffic
<b>Permanent load</b>								
<b>Self-weight</b>	1.35	1.20	1.35	1.20	1.35	1.20	1.20	1.20
	1.00	1.00	1.00	1.00	1.00	1.00	1.00	1.00
<b>Prestressing</b>	1.10	1.10	1.10	1.10	1.10	1.10	1.10	1.10
	0.90	0.90	0.90	0.90	0.90	0.90	0.90	0.90
<b>Creep, shrinkage, relaxation</b>	1.00	1.00	1.00	1.00	1.00	1.00	1.00	1.00
<b>Variable load</b>								
<b>Traffic load LM1</b>	0.95	1.35	-	-	-	-	0.95	-
<b>Traffic load LM2</b>	-	-	0.95	1.35	-	-	-	-
<b>Wind with traffic</b>	1.12	1.12	1.12	1.12	-	-	1.12	-
<b>Wind without traffic</b>	-	-	-	-	1.12	1.60	-	1.12
<b>Temperature</b>	0.84	0.84	0.84	0.84	0.84	0.84	1.20	1.20

Table 7.8 SLS characteristic load combination

Combination	Characteristic						
	1	2	3	4	5	6	7
<b>Permanent load</b>							
<b>Self-weight</b>	1.00	1.00	1.00	1.00	1.00	1.00	1.00
<b>Prestressing</b>	1.00	1.00	1.00	1.00	1.00	1.00	1.00
<b>Creep, shrinkage, relaxation</b>	1.00	1.00	1.00	1.00	1.00	1.00	1.00
<b>Variable load</b>							
<b>Traffic load LM1</b>	1.00	-	-	0.70	-	0.70	-
<b>Traffic load LM2</b>		1.00	-	-	0.70	-	0.70
<b>Wind with traffic</b>	0.70	0.70	-	0.70	0.70	1.00	1.00
<b>Wind without traffic</b>	-	-	1.00	-	-	-	-
<b>Temperature</b>	0.70	0.70	0.70	1.00	1.00	0.70	0.70

Table 7.9 SLS frequent load combination

Combination	Frequent						
	1	2	3	4	5	6	7
<b>Permanent load</b>							
Self-weight	1.00	1.00	1.00	1.00	1.00	1.00	1.00
Prestressing	1.00	1.00	1.00	1.00	1.00	1.00	1.00
Creep, shrinkage, relaxation	1.00	1.00	1.00	1.00	1.00	1.00	1.00
<b>Variable load</b>							
Traffic load LM1	0.70	-	0.20	-	0.20	-	-
Traffic load LM2	-	0.70	-	0.20	-	0.20	-
Wind with traffic	-	-	-	-	0.60	0.60	-
Wind without traffic	-	-	-	-	-	-	0.60
Temperature	-	-	-	0.60	-	-	-

Table 7.10 SLS quasi-permanent load combination

Combination	Quasi-permanent						
	1	2	3	4	5	6	7
<b>Permanent load</b>							
Self-weight	1.00	1.00	1.00	1.00	1.00	1.00	1.00
Prestressing	1.00	1.00	1.00	1.00	1.00	1.00	1.00
Creep, shrinkage, relaxation	1.00	1.00	1.00	1.00	1.00	1.00	1.00
<b>Variable load</b>							
Traffic load LM1	0.50	-	0.20	-	0.20	-	-
Traffic load LM2	-	0.50	-	0.20	-	0.20	-
Wind with traffic	-	-	-	-	0.50	0.50	0.50
Wind without traffic	-	-	-	-	-	-	-
Temperature	-	-	0.50	0.50	-	-	-

## 8 NOVAFRAME

Nova Frame is a Windows-program for static and dynamic analysis of three dimensional frame structures. The program is based on the finite element method. The program enables to create models in different building stages.

### 8.1. Preprocessor

#### 8.1.1. Material properties

All cross sections should be assigned a material type and a corresponding design parameter set. The material data are used in both the frame analysis and in design calculations. Design parameter data are, as the name reveals, primarily used in design calculations.

##### 8.1.1.1. Concrete

Concrete class B45 within concrete cylinder strength  $f_{ck} = 45$  MPa and E-modulus to 36000 MPa.

##### 8.1.1.2. Reinforcement

Type B500NC characteristic yield strength  $f_{yk} = 500$  MPa.

##### 8.1.1.3. Tendons

Characteristic yield strength  $f_{p0,1k} = 1600$  MPa

#### 8.1.2. Reference line input

The idea of a reference line is to introduce the concept of roads and railways more directly into the design process and to reduce the work of generating geometry input data

##### 8.1.2.1. Reference line

In the reference line tab “cross-sections”, the axes are described. Reference line 0 is used for the cross-sections.

##### 8.1.2.2. Axis

This tab defines the distance between vertical axes. The axes are numbered.

### 8.1.2.3. *Horizontal geometry*

This is used for defining straight or curved segments representing the projection of the road in the horizontal plane.

A 75 m straight line is used in this master's thesis.

### 8.1.2.4. *Vertical geometry*

The vertical curvature of the road geometry is given by defining vertical segments. These consist of straight lines or circular curves.

The data for such segments include start elevation and start station, end station and end elevation, and radius of the curved segment if this is a circle.

### 8.1.2.5. *Column*

The column definition consists of connecting a reference line with vertical projection at a specific station of reference line with projection in the XY-plane. The coordinate at the specified station or axis is calculated and the geometry of the column reference line is automatically calculated.

In axis 1 and 4, the connection between girder and column is movable by bearings. In axis 2 and 3, the connection is monolithic. The columns are associated to the vertical axis. Top elevation is calculated automatically and bottom elevation of each column is set.

## 8.1.3. *Cross Sections*

### 8.1.3.1. *Section*

Sections are associated with reference lines.

For the deck cross section, the section type "general massive" is chosen. For the foundations and columns – "massive predefined - rectangular concrete". The bearing – "frame section general". Where the E modulus is set 30000 MPa.

### 8.1.3.2. *Dimensions*

The dimensions of all massive predefined – a rectangular cross section is entered in this tab.

### 8.1.3.3. *Points*

The general, user defined section geometry is entered as a series of section points defining the section surface. A continuous line interconnects the section points. The cross section area is automatically taken as the area enclosed by this continuous line.

## 8 NovaFrame

The cross section is entered by points with x and y coordinates. The cross section of the deck is shown in Figure 33.

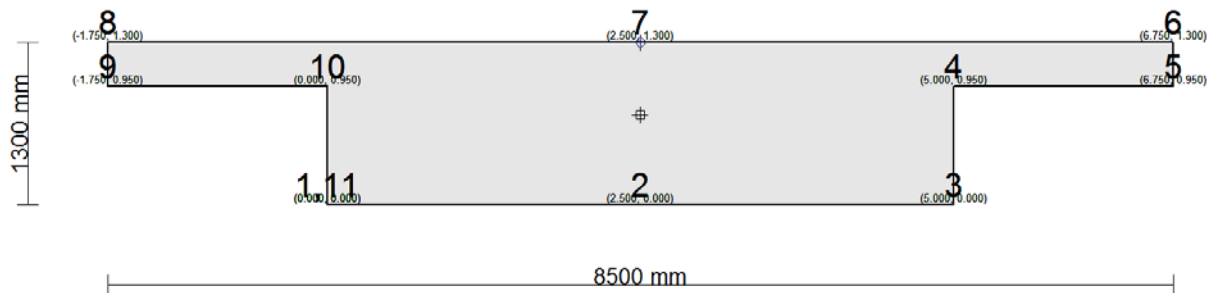

Figure 33 Cross section of the deck, with points and their coordinates.

### 8.1.3.4. Reference line connection

By default the intersection point is the centre of gravity, but in this project the reference line is set to be at point 7 (see Figure 33). The reason is that this makes building the model easier.

### 8.1.4. Geometry input

The first step in modelling a frame is to divide the frame into elements and nodes. An element is a straight line between two nodes.

#### 8.1.4.1. Nodes

Node data are entered by axis and reference lines. The foundations are 1 height thus nodes 10-11, 20-21, 30-31 and 40-41 have a distance of 1 m. The columns are defined between nodes 11-13, 21-29, 31-39 and 41-43. The deck is defined between nodes 101 and 501 (increment 10). For the position of the nodes see Figure 34.

Due to construction stages, nodes 241 and 411 are assumed to be in the construction joints. (5,6 m right from axis 2 and 3).

The nodes for bearing 5001-5008 are explained in section 8.1.4.4.

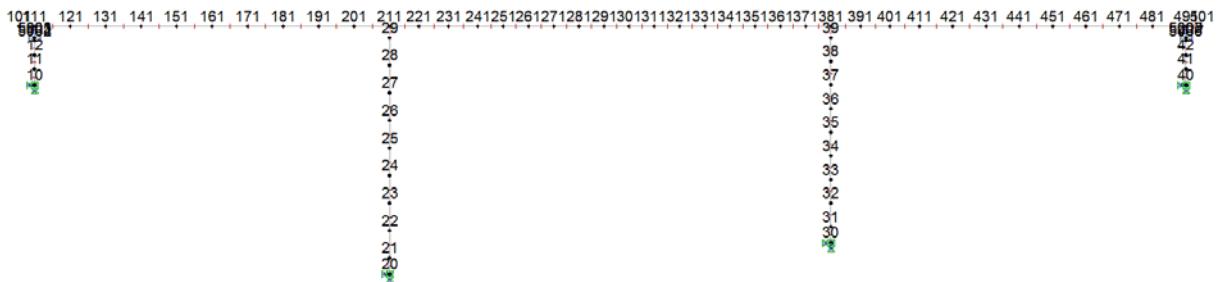

Figure 34 Node numbers

### 8.1.4.2. Elements

Elements are situated between two nodes and placed on the reference lines. The deck has element between 100 and 490. The columns 10-11, 21-28, 31-38 and 41-42. For the foundations element 10, 20, 30 and 40 are assumed. The bearings have elements 5010-5013.

For position of the elements see

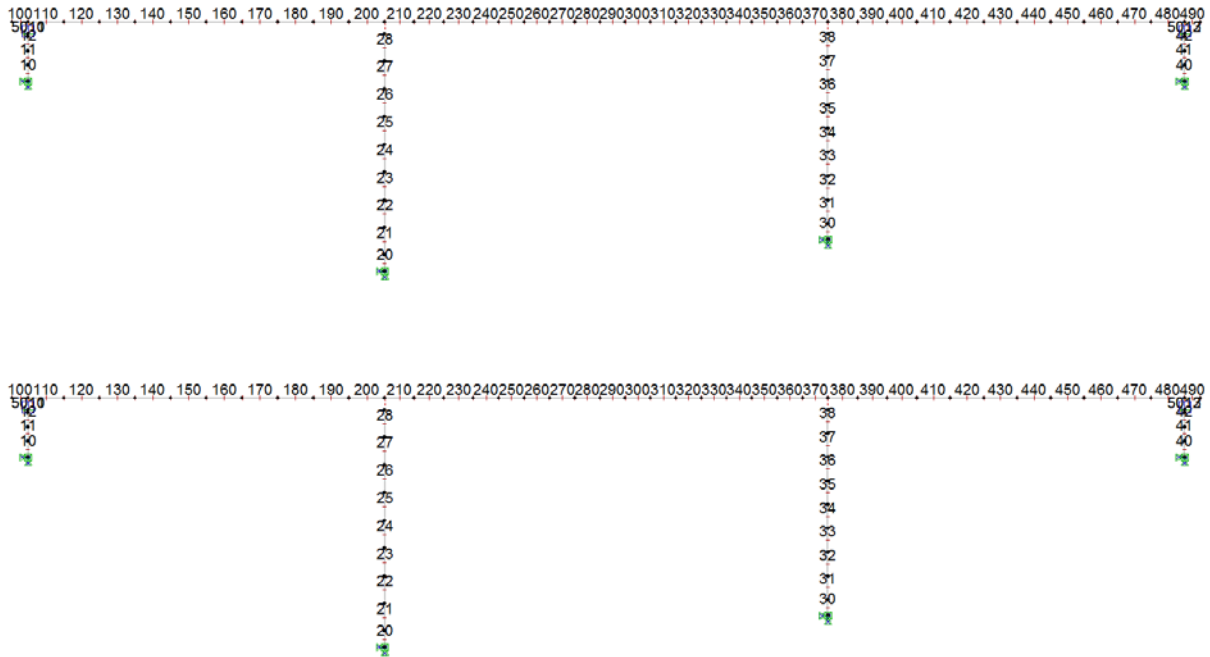

Figure 35 Element numbers

### 8.1.4.3. Element specification.

Cross sections which are not associated to the reference line has to be connected to an element. In this master's thesis only the foundation and bearing cross section are specified.

### 8.1.4.4. Boundaries conditions and joints

Boundary conditions in NovaFrame are defined as fixed degrees of freedom for selected nodes or a master-slave connection between selected nodes.

The bottom of the foundation is assumed as a fixed support (translation and rotation are fixed). The joints between the columns in axes 2 and 3, and the deck are specified by the master-slave connection (fixed joint). The joint between the column and concrete deck in axes 1 and 4 uses bearing.

The detail of the boundary conditions and the joint in axis 1 are shown in Figure 36

## 8 NovaFrame

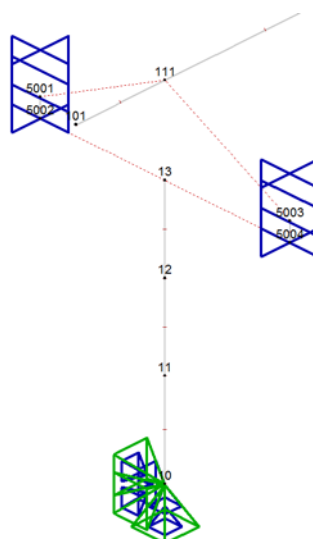

Figure 36 Detail of the boundaries and joints in axis 1

### 8.1.4.5. Design sections

By default setting the elements are divided to three sections.

### 8.1.5. Tendon input

NovaFrame supports both post- and pre-tensioned tendons. For the purpose of this master's thesis the post-tensioned tendons are used.

#### 8.1.5.1. Tendons

The material properties for the tendons are shown in chapter 4. 2250 mm<sup>2</sup> is entered as the size of a tendon. 5 tendons are designed according to the building stages. 1 tendon for the 1<sup>st</sup> stage, 2 tendons for the 2<sup>nd</sup> stage and 2 tendons for the 3<sup>rd</sup> stage. The duct diameter is 100 mm and the grout strength is 45 MPa.

#### 8.1.5.2. Group data

5 tendon groups are entered. 6 tendons in the cable group 1 in the 1<sup>st</sup> stage. 4 tendons in the cable group 2 + 4 tendons in the cable group 3 in the 2<sup>nd</sup> stage, 4 tendons in the cable group 4 + 2 tendons in the cable group 5 in the 3<sup>rd</sup> stage. This corresponds to 6 cables in the side spans, 8 cables in the middle span and 10 cables over the columns in axes 2 and 3.

The spacing is set 300 mm, but in reality the cables are placed at different spacing.

#### 8.1.5.3. Geometry type

The tendons are associated to the deck cross section and its centre of gravity.

### 8.1.5.4. Geometry

The position of cable groups are shown in Figure 37 to Figure 41 below. The maximal eccentricity in the spans is 575 mm and over the columns is 400mm. It has a parabolic shape.

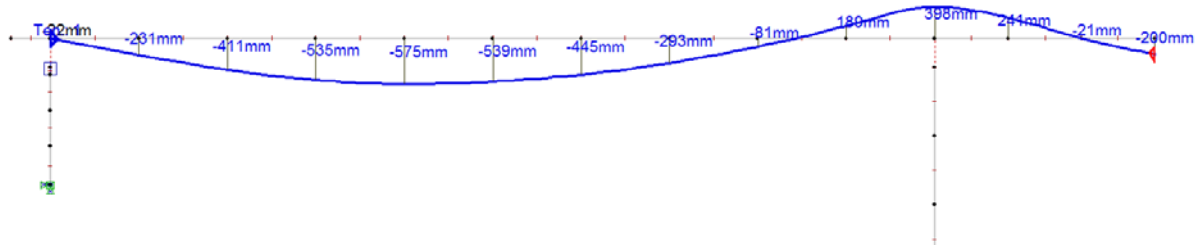

Figure 37 Position of cable group 1 in the edge span

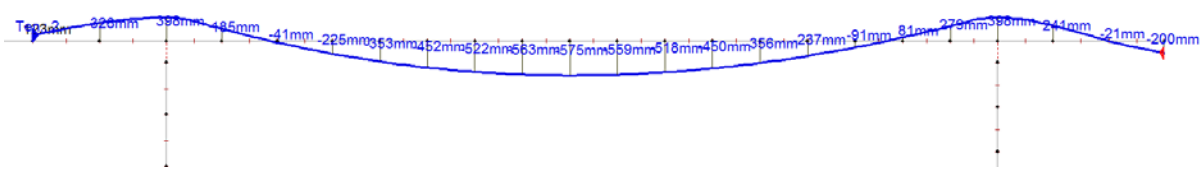

Figure 38 Position of cable group 2 in the middle span

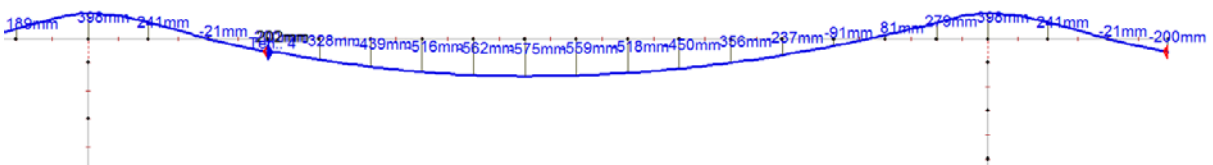

Figure 39 Position of cable group 3 in the middle span with shown connection to the cable group 1.

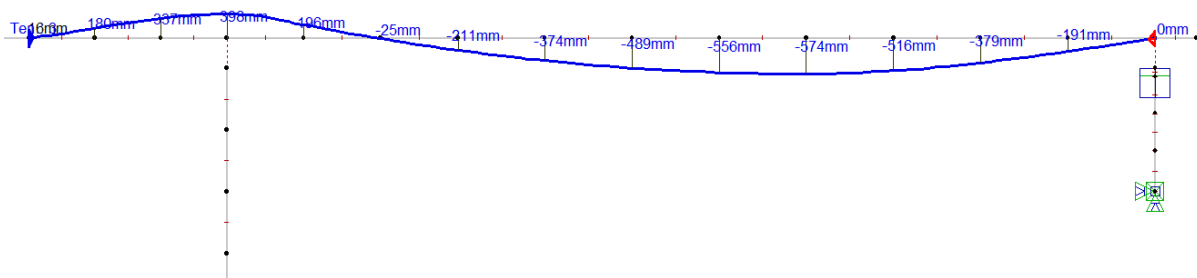

Figure 40 Position of cable group 4 in the edge span



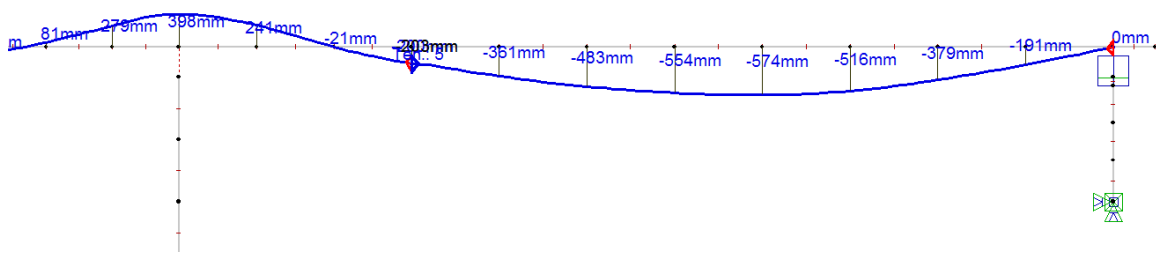

Figure 41 Position of cable group 5 in the side span with shown connection to the cable group 2.

#### 8.1.5.5. Loss parameters

According to ETA 06/0022 for the outer diameter of a duct of 100 mm, the friction coefficient  $\mu = 0.19$  [rad<sup>-1</sup>]. The anchorage slip is set to 6 mm. The Wobble coefficient  $k = 5 \cdot 10^{-3}$  [rad/m].

NovaFrame uses the following equation for calculating short-term losses:

$$P(x) = P_0 \cdot e^{-(\mu \cdot \alpha + k \cdot x)}$$

Eurocode uses another equation:

$$P(x) = P_0 \cdot e^{-\mu(\alpha + k \cdot x)}$$

Because NovaFrame uses the wrong equation, the Wobble coefficient must be multiplied by the friction coefficient  $\mu$ . The value for the Wobble coefficient in NovaFrame is therefore set to  $k = 0.00095$  [rad/m].

The properties for relaxation were provided by Statens vegvesen as: Tension reinforcement used in Norway Class 2, low relaxation, according to EN 1992, section 3.3.2 (5), with less than 2.5% relaxation after 1000 hours at  $0.7 f_{pk}$ . Furthermore, it is common, based on information from suppliers and test results, to be reckoned with 4.5% relaxation at  $0.8 f_{pk}$ . Thus, there are two points on a line that describes the relationship between the stress level ( $f_{p0,1k} / f_{pk}$ ) and relaxation (%). This line can be extrapolated, giving zero relaxation at  $0.575 f_{pk}$ . The loss in the tendon due to relaxation is accounted for by defining a simplified curve as shown in Figure 42

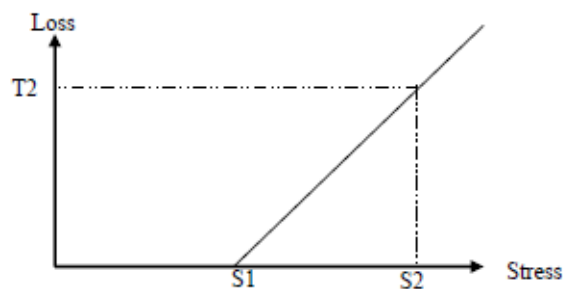

Figure 42 Relaxation curve in NovaFrame [16]

Set points are given in % of  $f_{p0,1k}$  in NovaFrame, which provide the following inputs:

$$S1 = 57,5 * \frac{1860 \text{ MPa}}{1640 \text{ MPa}} = 65$$

$$S2 = 70,0 * \frac{1860 \text{ MPa}}{1640 \text{ MPa}} = 79$$

$$T2 = 2,5$$

The creep strain is calculated in Appendix G and it is set to  $\epsilon_{cc} = -0,230\%$ . The shrinkage in Appendix G and it is set  $\epsilon_{cs} = -0,2942\%$

#### 8.1.5.6. Stressing

Stressing of the cables is 90% of  $f_{p0,1k}$  1600 MPa. Furthermore all cables will be jacked from active anchorages, which corresponds to stressing at end 2.

#### 8.1.6. Load Data

NovaFrame includes several different load categories. These include large numbers of static, traffic dynamic and creep loads. The loads are defined in the following sections.

##### 8.1.6.1. Loads

The loads are applied on elements of the model. All loads must be assigned to a load cases in NovaFrame

#### Self-weight

The self- weight is calculated automatically, only the density of the concrete is entered, 25 kN/m<sup>3</sup>.

#### Distributed load

The additional load, 40 kN/m (restraint systems, kerb, edge beams, tarmac) is entered to the elements which represent the concrete deck.

#### Temperature

The uniform bridge and vertical linear component are entered.  $T_{heat}$ ,  $T_{cool}$ ,  $T_{exp}$  and  $T_{con}$  are calculated according to the User's guide. The thermal coefficient is by default  $\alpha = 10^{-5} \text{ m/}^\circ\text{C}$ , which is applicable for concrete. Temperature gradient has to be calculated according to Figure 43.

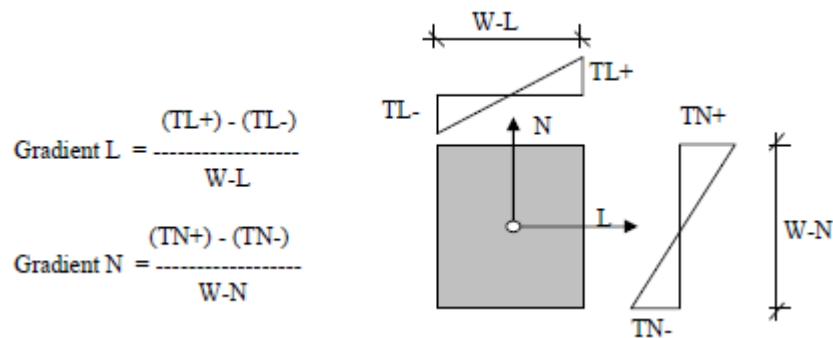

Figure 43 Temperature gradient [16]

### Wind load

The definition of the wind load in NovaFrame is no longer used since the wind load is entered as a distributed load with and without traffic. The wind load in z-direction is entered with eccentricity 2,375 m from the centre line. The wind load in x-direction is not used in this master's thesis.

### Traffic load

Only the break and lateral forces are entered as distributed loads, because there is not such a load in the traffic load tab. The vertical loads are described in 8.1.6.3.

### Tendon

The tendons are entered as full forces and constrained (parasite) forces because of usage in ULS and SLS. The tendons are entered according to the building stages.

Creep, Shrinkage and Relaxation all implies time dependant losses, thus the losses are calculated automatically.

### Shrinkage

Shrinkage load consists of an applied (axial) strain in the specified elements and is set to 0,300 ‰.

#### 8.1.6.2. Traffic line

The traffic line is defined between element 100 and 490 and corresponds to the concrete deck.

#### 8.1.6.3. Traffic load

Traffic load is entered for LM1 and LM2. Each traffic load case automatically allocates 12 load case numbers, so in this master's thesis the traffic load cases have an increment of 20.

Traffic load case 161 LM1 – for purpose of torsional moment, load are divided into the notional lanes. This load is available in list of loads in NovaFrame. Eccentricities are set as shown in Figure 44 and Figure 45.

Traffic load case 181 LM2 – only a vertical force of 400 kN with corresponding eccentricities. Eccentricities are set as shown in Figure 44 and Figure 46.

Traffic load case 201 LM1 – for the purpose of maximal vertical moments. The eccentricities are neglected. All notional lanes are summarized into 1 central load. The single axle load is 500 kN and the distributed load is 29,95 kN/m.

The eccentricities are according to 7.3 Traffic loads.

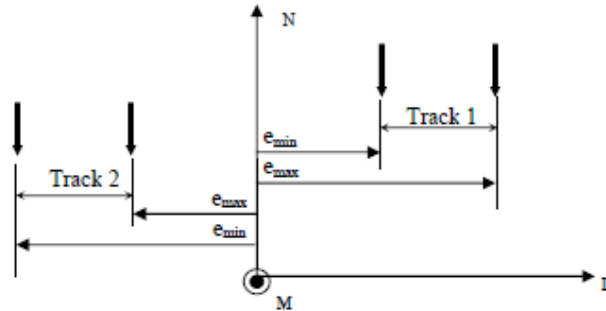

Figure 44 The definition of tracks end eccentricities. The traffic load is positioned at  $e_{max}$  or  $e_{min}$ . [10]

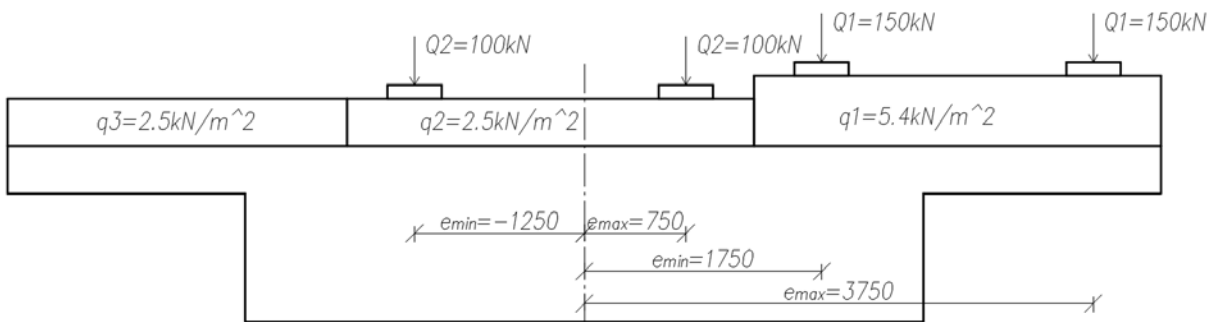

Figure 45 Eccentricities for load model 1

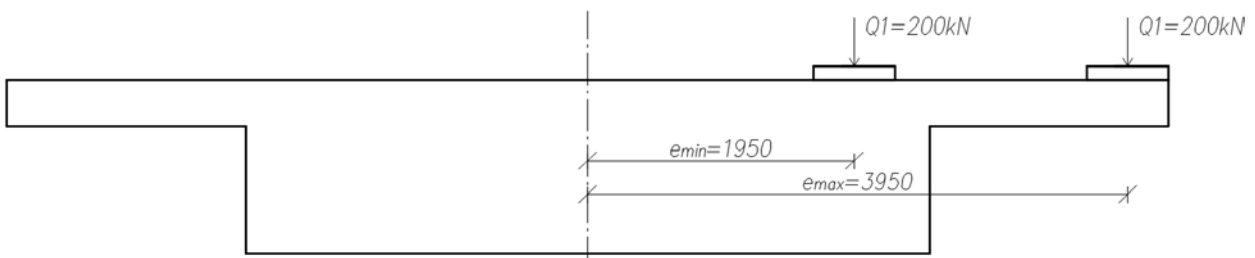

Figure 46 Eccentricities for load model 2

#### 8.1.6.4. Creep combinations

First a stress level is defined by assigning defined loadcases to a creep combination. The self-weight cases are added into the account.

The creep combination follows the different building stages and the creep after 112 days and 100 years.

#### 8.1.6.5. Creep loads

The creep loads are set for each element according to the building phase. The values are entered manually. The basic for the creep coefficients is found in section 7.6.

#### 8.1.7. Models and analyse

For structures which are constructed and loaded in different sequences it is required to run several analyses with different static models. There are facilities included in NovaFrame enabling this to be handled effectively.

##### 8.1.7.1. Models

This tab defines which element belongs to each building stage and it creates different static systems. In this master's thesis three building stages are introduced. Columns, foundations and the first slab between axis 1 and 5,6 m to the right from axis2 are built in 1<sup>st</sup> stage. In the 2<sup>nd</sup> stage, the middle span + 5,6 m to the right from axis 3 are built. 3<sup>rd</sup> (final) stage contains the last part between axis 3 and 4 and the bearings.

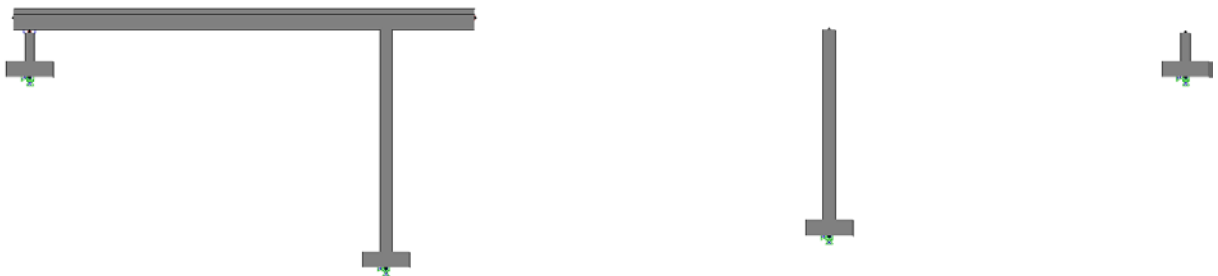

Figure 47 Model for 1<sup>st</sup> stage



Figure 48 Model for 2<sup>nd</sup> stage



Figure 49 Model for final stage

### 8.1.7.2. Calculation groups

The following types of analyses are entered:

- Ordinary static analysis, the contents of the calculation group is loadcases.
- Traffic load analysis, the contents of the calculation group is traffic loads.
- Creep analysis, the contents of the calculation group is a single creep load (case).

### 8.1.7.3. Analysis

This tab defines an analysis consisting of a model and a calculation group.

When solving this analysis the geometry of the selected model will be analysed for the contents of the selected calculation group.

## 8.2. Solve

When the model is set we can continue with the solver

### 8.2.1. Solve analysis

It runs all defined analysis and no error should appear

## 8.3. Postprocessor

In the postprocessor, we can make a load combination and find results of the combinations.

### 8.3.1. Load combinations

#### 8.3.1.1. Ordinary load combination

In this tab, self-weight from all the building stages are assembled together and added to the additional other self-weight, giving the total self-weight combination. The temperature loads are combined together according to the temperature combination from 7.4. Creep and prestressing are also introduced in this tab.

#### 8.3.1.2. Sort combination

The most important part in NovaFrame. The correct results depend on correct import of values. In this tab all ULS and SLS combinations are entered according to part 7.8 Load combination. The sort combinations can be created from different combination types:

- Load case
- Ordinary load combination
- Traffic load
- Sort combination

Method of combinations:

- add all
- only the worst
- add if unfavourable

In this part all load factors are entered, see: Table 7.7 to Table 7.10

#### 8.3.1.3. Sort combination line

This tab introduces the final step for the load combinations. The sort combination line assembles all relevant sort combinations for ULS and SLS. The result of this is an envelope for each sort combination.

### ***8.3.2. Plot analysis results***

All diagrams (axial, shear, moments and torsion) for every building stage and plot types are available in this menu. The plot types include:

- Load cases
- Load combinations
- Traffic loads
- Sorted combination lines

### ***8.3.3. Plot traffic positions***

The most unfavourable positions of the traffic load can be found in this tab. The traffic diagram envelopes are found in the plot analysis results.

### ***8.3.4. List results***

The complete list of every single load is found in this tab. The forces can be found on each element.



## 9 VERIFICATIONS OF THE ANALYTICAL MODEL IN NOVAFRAME

The model for verification of the NovaFrame results is simplified for the better handling in hand calculation. The static model is introduced in Figure 50 Static model. Self-weight, traffic load and temperature load are verified.

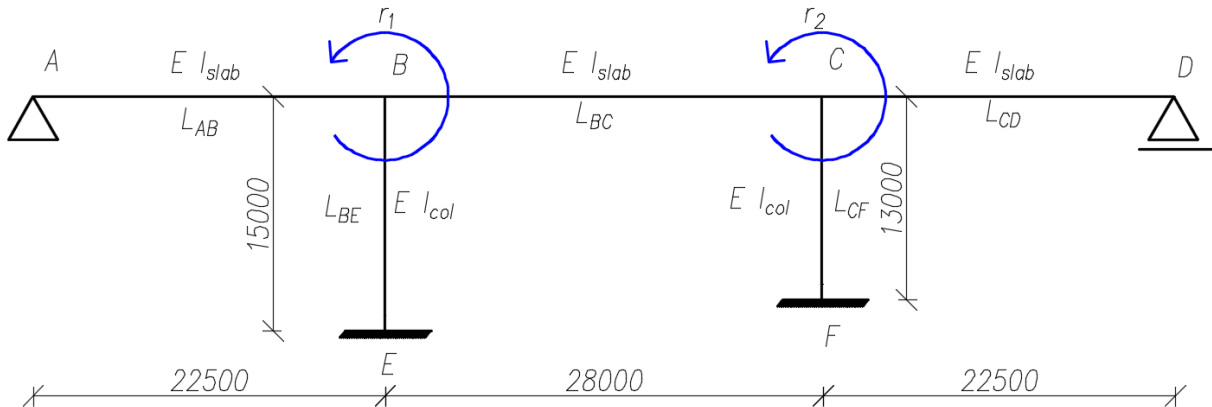

Figure 50 Static model

### 9.1. Self-weight

The self-weight in NovaFrame is calculated automatically from the cross-sections. The area of the cross section is 7,725 m<sup>2</sup>. The weight of the concrete is assumed to be 25 kN/m<sup>3</sup>.

$$g = 7,725 \text{ m}^2 * 25 \text{ kN/m}^3 = 193,125 \text{ kN/m}$$

The complete hand calculations is found in Appendix I

The moment and shear diagram are shown below. A comparison is shown in Table 9.1 and Table 9.2. The result shows that the result from both calculations are similar and we can assume that NovaFrame's results are correct.

## 9 Verifications of the analytical model in NovaFrame

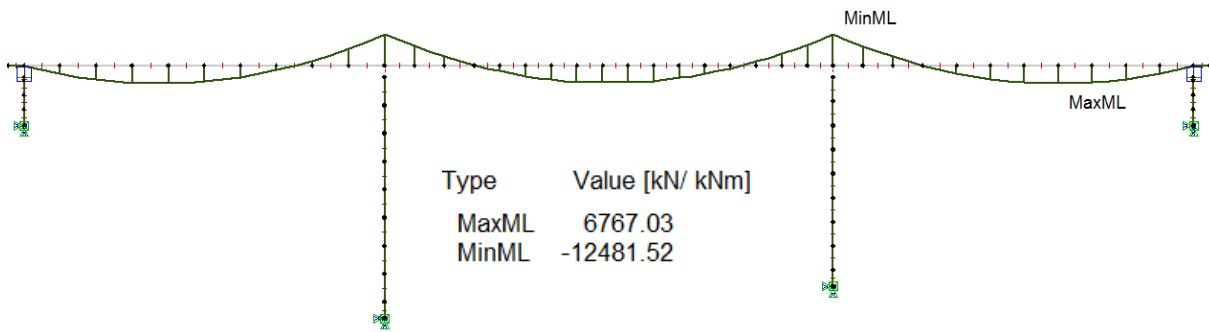

Figure 51 Moment diagram for self-weight in NovaFrame

Table 9.1 Comparison between NovaFrame and hand calculation results for the bending moment

	Span 1	Support B	Span 2	Support C	Span 3
<b>NovaFrame [kNm]</b>	6751.88	-12449.72	6445.65	-12481.52	6767.03
<b>Hand calculation [kNm]</b>	6797	-12504	6419	-12511	6798
<b>Difference</b>	0.7%	0.4%	0.4%	0.2%	0.5%

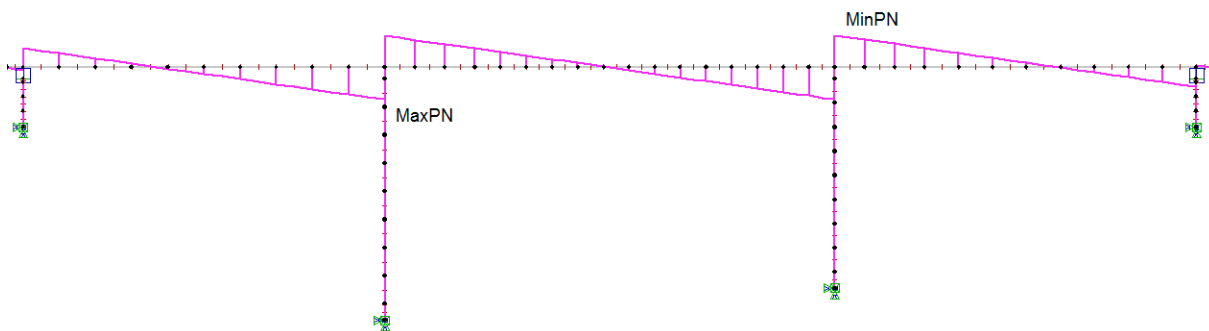

Figure 52 Shear diagram for self-weight in NovaFrame

Table 9.2 Comparison between NovaFrame and hand calculation results for the shear forces

	$V_{AB}$	$V_{BA}$	$V_{BC}$	$V_{CB}$	$V_{CD}$	$V_{DC}$
<b>NovaFrame [kN]</b>	1629.99	-2715.31	2702.6	-2704.88	2717.08	-1628.21
<b>Hand calculation [kN]</b>	1620	-2725	2704	-2725	2704	-1620
<b>Difference</b>	0.6%	0.4%	0.1%	0.7%	0.5%	0.5%

## 9.2. Traffic load

Load model LM1 has been compared in NovaFrame and Scia Engineer 14 as shown in Figure 53 to Figure 56. The results from both programs are similar ( see Table 9.3), and it is therefore assumed that the traffic load in NovaFrame is inserted and calculated correctly.

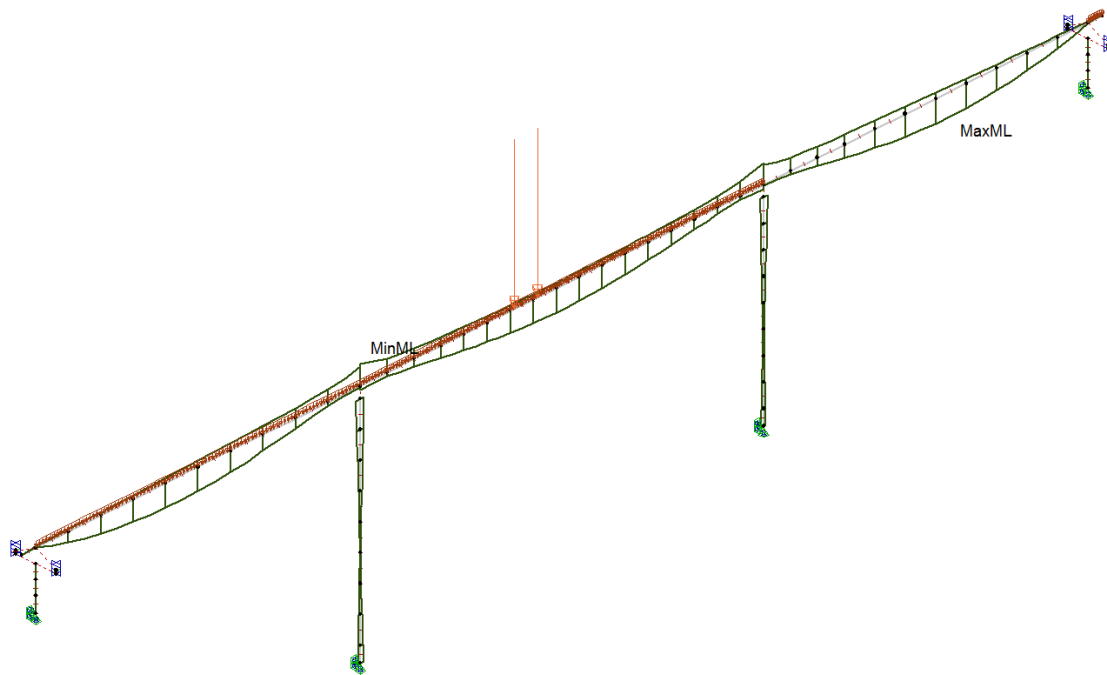

Figure 53 Position of load model LM1- maximum support moment

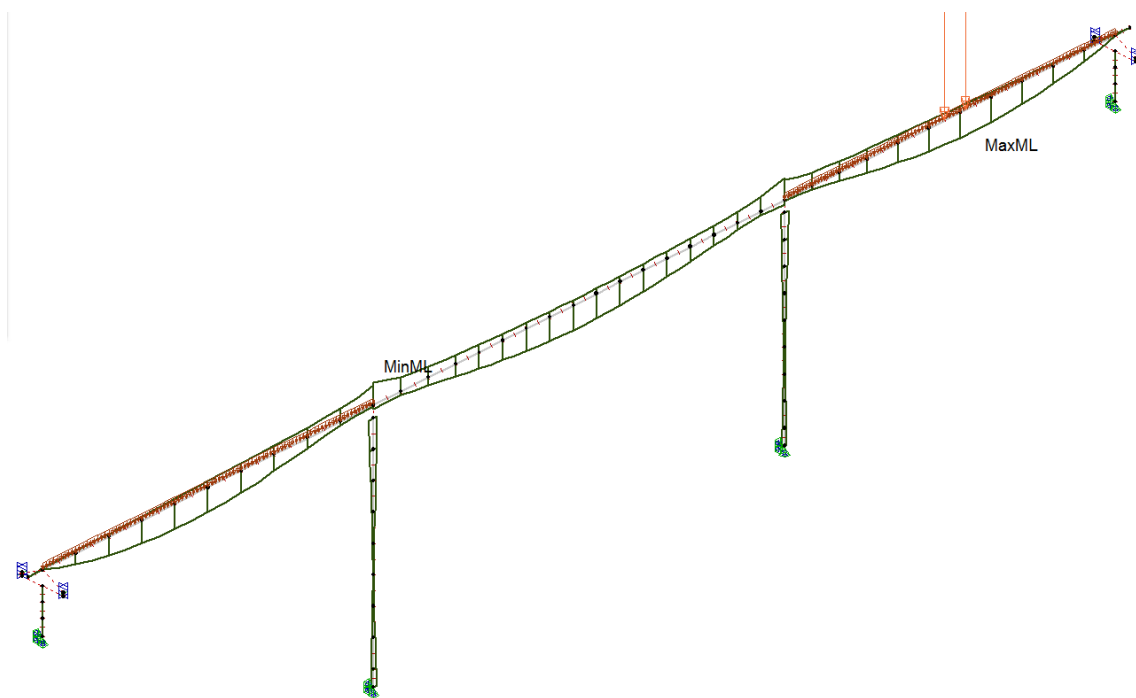

Figure 54 Position of load model LM1- maximum span moment

## 9 Verifications of the analytical model in NovaFrame

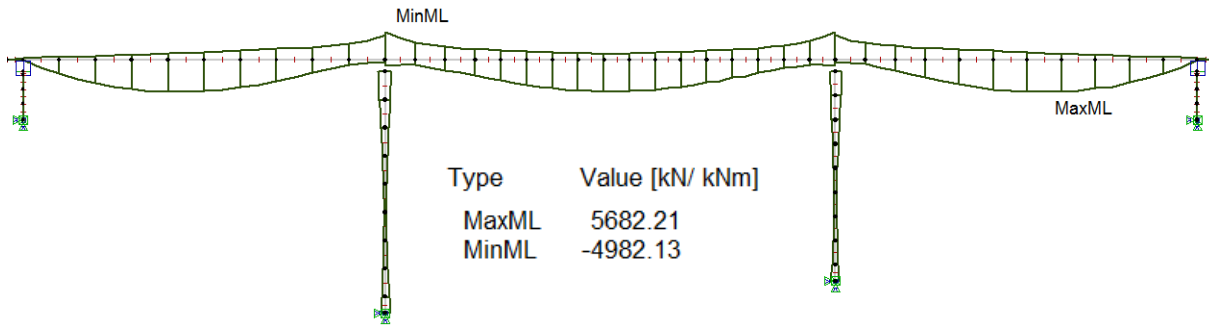

Figure 55 Moment diagram for load model LM1 in NovaFrame

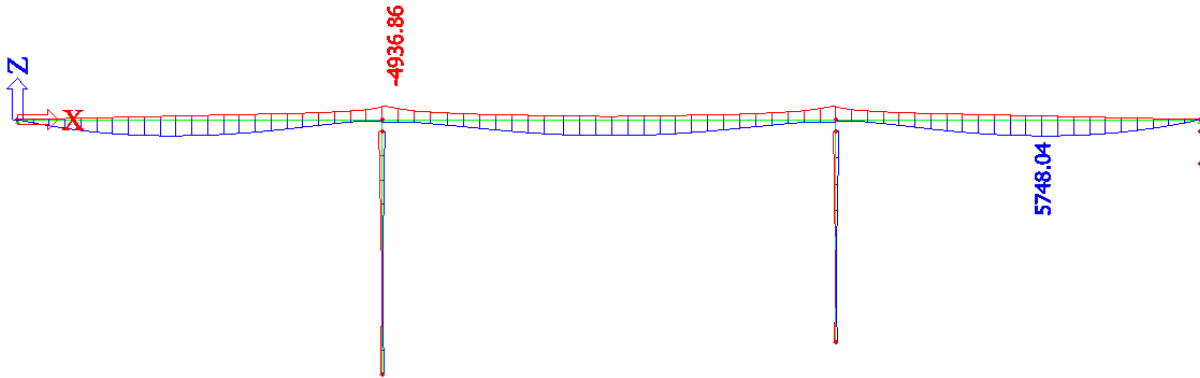

Figure 56 Moment diagram for load model LM1 in Scia Engineer

Table 9.3 Comparison between NovaFrame and Scia Engineer results for the traffic load

	Support	Span
<b>NovaFrame [kNm]</b>	-4982.13	5682.21
<b>Scia [kNm]</b>	-4936.86	5748.04
<b>Difference</b>	0.9%	1.2%

### 9.3. Wind load

The model and calculations are similar to the verification of self-weight. The uniform load for wind in z-direction without traffic is shown below:

$$q_{wind} = 9,5 \text{ kN/m}$$

Bending moments and shear diagrams are shown in Figure 57 and Figure 58. The complete hand calculation is found in Appendix J

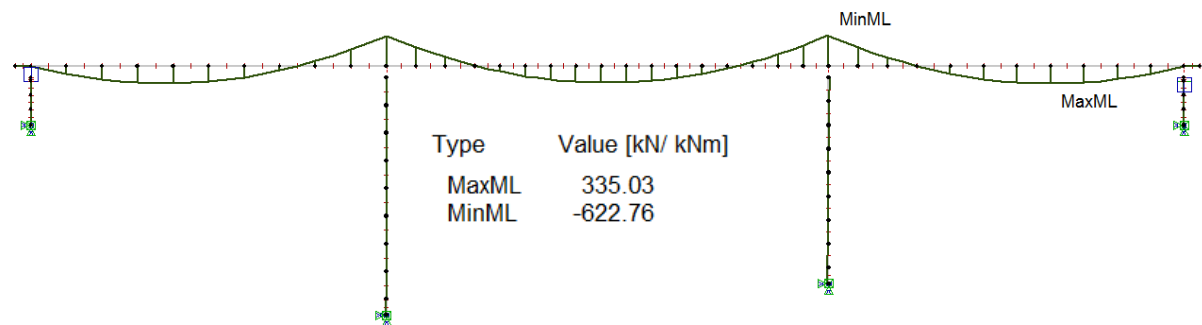

Figure 57 Moment diagram for wind load in NovaFrame

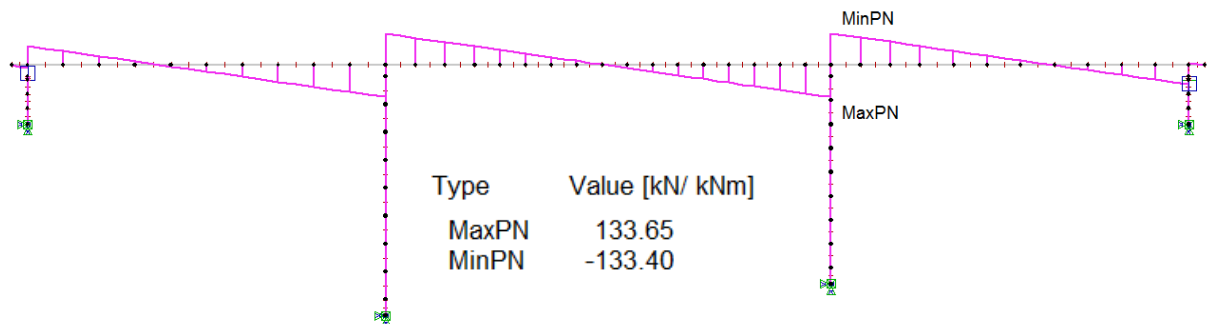

Figure 58 Shear diagram for wind load in NovaFrame

Table 9.4 Comparison between NovaFrame and hand calculation results for the wind load

	$M_{\max}$ span [kNm]	$M_{\min}$ support [kNm]	$V_{\max}$ [kN]	$V_{\min}$ [kN]
<b>NovaFrame</b>	335	-622	133	-133
<b>Hand calculation</b>	334	-615	134	-134
<b>Difference</b>	0.3%	1,1%	0.7%	0.7%

## 9.4. Temperature load

The temperature load from NovaFrame has been compared with Scia Engineer and hand calculation. The results from hand calculation are slightly higher due to the simplification of the model for hand calculation. (The rotation is not fixed in points E and F) and the results are shown in Table 9.5 and Table 9.6. Bending moments are shown in Figure 59 and Figure 60. The complete hand calculation is found in Appendix J

The results from both the programs are similar, because they express the same model in a similar manner.

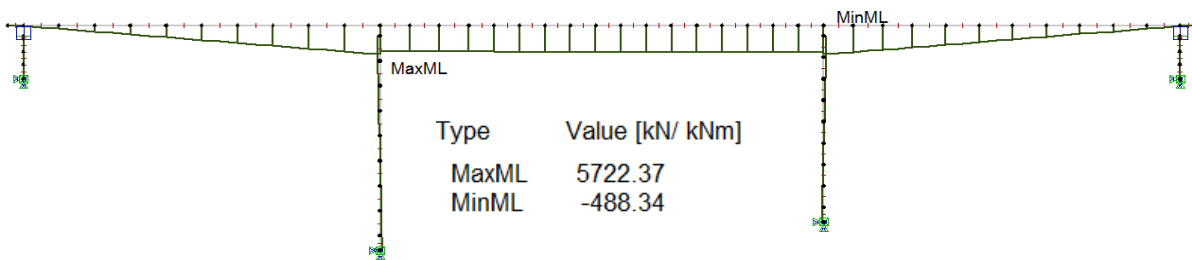

Figure 59 Moment diagram for temperature gradient  $\Delta T_{max} = 15^\circ$  in NovaFrame

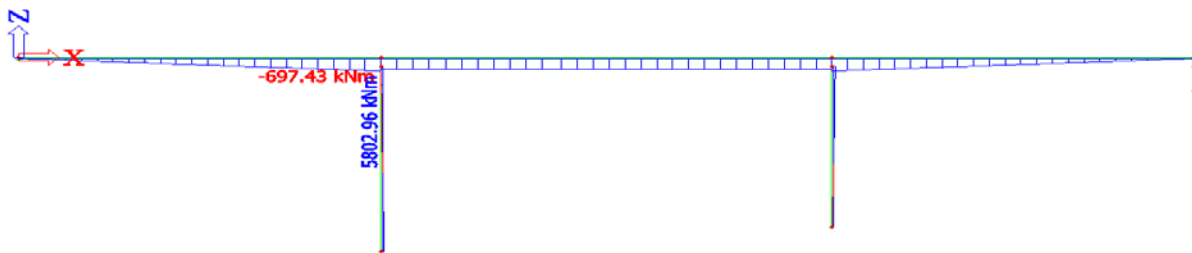

Figure 60 Moment diagram for temperature gradient  $\Delta T_{max} = 15^\circ$  in Scia Engineer

Table 9.5 Comparison between NovaFrame and Scia Engineer results for the temperature load

	$M_{BA}$	$M_{BC}$	$M_{CB}$	$M_{CD}$
<b>NovaFrame [kNm]</b>	5722.37	5150.97	5176.84	5708.48
<b>Scia [kNm]</b>	5802.96	5046.78	5087.86	5779.47
<b>Difference</b>	1.4%	2.1%	1.7%	1.2%

Table 9.6 Comparison between NovaFrame and hand calculation results for the temperature load

	$M_{BA}$	$M_{BC}$	$M_{CB}$	$M_{CD}$
<b>NovaFrame [kNm]</b>	5722.37	5150.97	5176.84	5708.48
<b>Hand calculation [kNm]</b>	5971	5508	5470	5995
<b>Difference</b>	4.7%	6.4%	5.3%	4.7%

## 9.5. Prestressing

Since the bridge is a statically indeterminate structure the moment from the prestressing contains primary and secondary (parasite) moment.

$$M_{full} = M_{primary} + M_{secondary}$$

The primary moment is force in a cable times the cable eccentricity. Secondary moment is additional moments caused by deformation of the structure due to the applied forces.

Prestress losses are given in NovaFrame – List properties – Tendon losses properties and they are assumed for the various cable groups.

The positions of cables are shown in Figure 9 in section 4.3

### 9.5.1. In the middle span

In the middle span 8 cables are designed. The eccentricity is 575 mm.

$$e = -575 \text{ mm}, \quad P_{max} = 3240 \text{ kN}, \quad n_{cab} = 8$$

$$M_{mid.span} = P_{max} * e * n_{cab} = -14904 \text{ kNm}$$

Loss in middle span is 24,80 %

$$M_{primary.HC} = -14904 \text{ kNm} * (1 - 0.2408) = -11207 \text{ kNm}$$

From NovaFrame's moment diagram and list of result

$$M_{full} = -8109 \text{ kNm}$$

$$M_{primary.NF} = -11052 \text{ kNm}$$

$$M_{secondary} = 2943 \text{ kNm}$$

### 9.5.2. Over the support in axis 2

Over this support 2 cable groups are crossing. 6 cables from 1<sup>st</sup> stage and 4 cables from 2<sup>nd</sup> stage. This gives 10 cables in total. The eccentricity for both cable groups is 400 mm.

#### Cables from 1<sup>st</sup> stage

$$e = 400 \text{ mm}, \quad P_{max} = 3240 \text{ kN}, \quad n_{cab} = 6$$

$$M_{mid.span} = P_{max} * e * n_{cab} = 7776 \text{ kNm}$$

Loss over the support in axis 2 is 22,52 %

$$\text{Calculated: } M_{primary} = 7776 \text{ kNm} * (1 - 0.1961) = 6025 \text{ kNm}$$

From NovaFrame's moment diagram and list of result

$$M_{full}=7747 \text{ kNm}$$

$$M_{primary.NF}=5946 \text{ kNm}$$

$$M_{secondary}=1801 \text{ kNm}$$

### Cables from 2<sup>nd</sup> stage

$$e=400 \text{ mm}, P_{max}=3240 \text{ kN}, n_{cab}=4$$

$$M_{mid.span}=P_{max} * e * n_{cab}=5168 \text{ kNm}$$

Loss over the support in axis 2 is 33,83 %

$$M_{primary}=5168 \text{ kNm} * (1-0,3383)=3420 \text{ kNm}$$

$$M_{primary.tot.HC}=6025+3420=9445 \text{ kNm}$$

From NovaFrame's moment diagram and list of result

$$M_{full}=5231 \text{ kNm}$$

$$M_{primary}=3430 \text{ kNm}$$

$$M_{secondary}=1723 \text{ kNm}$$

Summary of the primary moment from both stages.

$$M_{primary.tot.NF}=9376 \text{ kNm}$$

Table 9.7 Comparison between NovaFrame and hand calculation results for the primary moment

	Middle span	Over support - axis 2
<b>NovaFrame [kNm]</b>	-11052	9376
<b>Hand calculation [kNm]</b>	-11207	9445
<b>Difference [kNm]</b>	155	69
<b>Difference</b>	1,4%	0,7%

The comparison of primary moments (see Table 9.7) shows that the NovaFrame calculates the moment from prestressing as desired.



### 9.5.3. Short-term losses

The simplified model for verification of short-term losses is shown in Figure 61. The single span is 22.5 m. The calculation of the short-term losses in in Appendix L

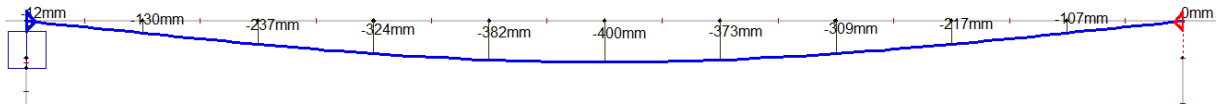

Figure 61 Simplified cable for short-term losses check in NovaFrame

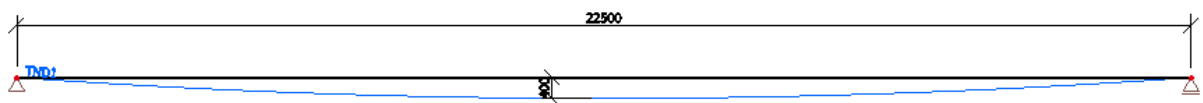

Figure 62 Simplified cable for short-term losses check in Scia Engineer

Table 9.8 Comparison between NovaFrame and hand calculation results for the friction loss at the left end

	Loss [%]
NovaFrame	4,08
Scia Engineer	4,72
Hand calculation	4,73

Table 9.9 Comparison between NovaFrame and hand calculation results for the anchorage slip at the right end

	Loss [%]
NovaFrame	7,63
Scia Engineer	7.76
Hand calculation	8,36

The results from Scia Engineer are shown in Figure 63 and Appendix M

Table 9.8 and Table 9.9 show that NovaFrame calculates the short-term losses relatively correct.

## 9 Verifications of the analytical model in NovaFrame

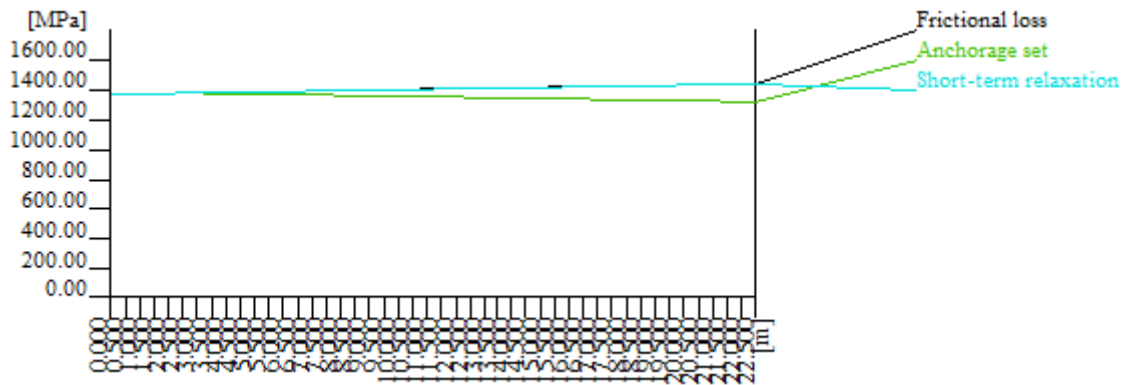

Figure 63 Short term losses in Scia Engineer

#### 9.5.4. Long-term losses

Long-term losses (creep, shrinkage and relaxation) have been compared. The hand calculation have been calculated by 2 different approaches according to EN 1992.

1<sup>st</sup> approach is a summary of creep, shrinkage and relaxation.

2<sup>nd</sup> approach is a simplified method, according EN 1992, section 5.10.6 (2)

The calculation of the long-term losses in in Appendix L

Table 9.10 Comparison between NovaFrame and hand calculation results for the long-term losses

	Loss [%]
<b>NovaFrame</b>	9,7
<b>Hand calculation 1<sup>st</sup> approach</b>	10,1
<b>Hand calculation 2<sup>nd</sup> approach</b>	10,7

The result in Table 9.10 show that the differences are negligible. Then we can assume that NovaFrame calculates long-term losses correctly.

## 10 ULTIMATE LIMIT STATE (ULS)

The complete calculation of the Ultimate limit state is found in Appendix O. The most important values are presented in this chapter.

### 10.1. Effective flange width

As a result of 'shear lag', the stress in the parts of a wide flange distant from the web would be much less than that at the flange-web junction. EN 1992-1-1 allows approximations by which an "effective" width can be calculated. A uniform distribution of stress is assumed over the effective width.

The effective width of a flange is based on the distance  $l_0$  between points of zero moment, which may be obtained from Figure 64 Definition of  $l_0$  for the calculation of the effective flange width. For purposes of this master's thesis the effective width is shown in Figure 65 and the summary of the effective flange widths are shown in Table 10.1

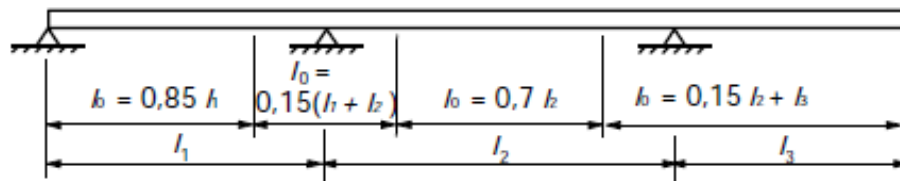

Figure 64 Definition of  $l_0$  for the calculation of the effective flange width [7]

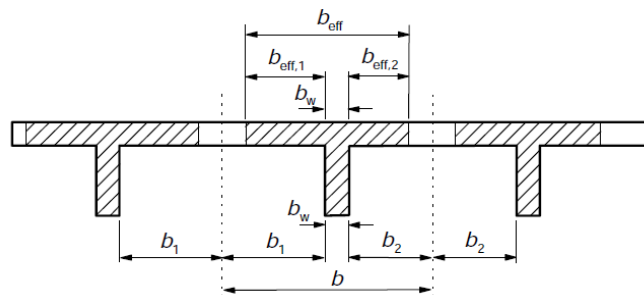

Figure 65 Effective flange width parameters [7]

Table 10.1 Effective flange widths

Location	$b_{\text{eff}}$
Side span	8,5 m
Middle span	8,5 m
Over support	7,215 m

The cross-section properties due to the effective width calculation are shown in Table 10.2. The position of neutral axis is shown in Figure 66

Table 10.2 Cross-section properties

	Span	Support
<b>A</b>	7,725 m <sup>2</sup>	7,2752 m <sup>2</sup>
<b>I<sub>y</sub></b>	1,16 m <sup>4</sup>	1,0796 m <sup>4</sup>
<b>I<sub>x</sub></b>	27,819 m <sup>4</sup>	20,850 m <sup>4</sup>
<b>COG<sub>z+</sub></b>	525 mm	598 mm
<b>COG<sub>z-</sub></b>	725 mm	702 mm

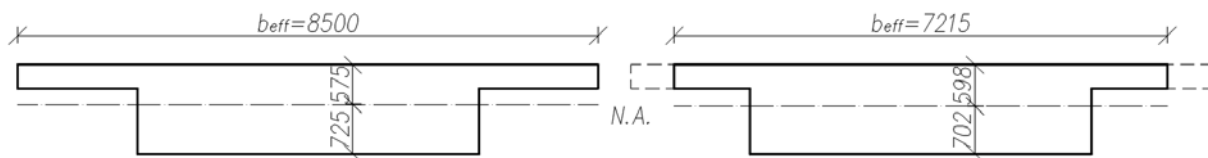

Figure 66 Position of neutral axis in cross-section in span and over support

## 10.2. Analysis results

The forces and moments diagrams are acquired from NovaFrame - sorted combinations. The diagrams show maximal and minimal forces and moments on the bridge.

### 10.2.1. Longitudinal direction

The diagrams in the longitudinal direction are provided for:

- parasite prestressing
- full prestressing

The diagrams for the parasite prestressing assume only parasite (secondary) forces on the bridge and are shown in Figure 67 through Figure 70.

The diagrams for the full prestressing assume both parasite and primary forces and are shown in Figure 71 through Figure 74.

The diagrams form the basis for calculating the Ultimate limit states of the bridge in the longitudinal direction.

## 10 Ultimate limit state (ULS)

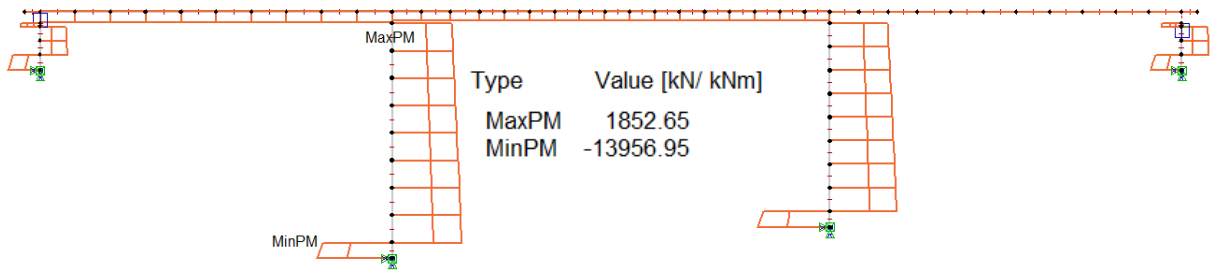

Figure 67 Axial force diagram – Parasite prestressing

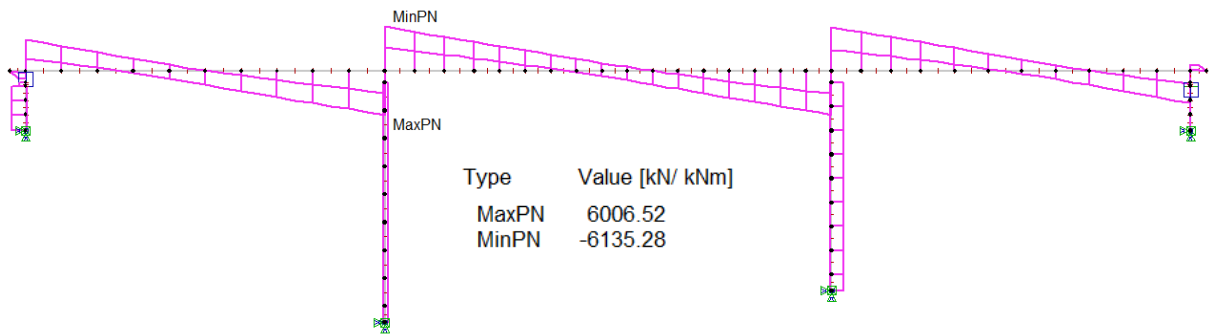

Figure 68 Shear force diagram – Parasite prestressing

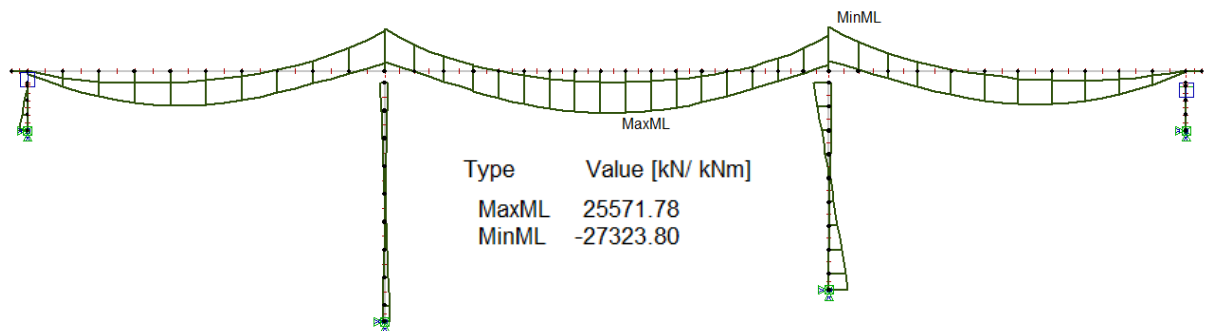

Figure 69 Bending moment diagram – Parasite prestressing

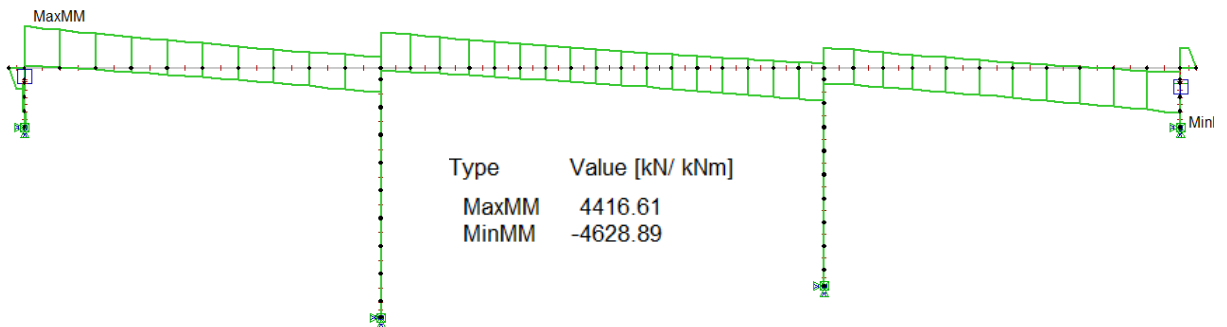

Figure 70 Torsional moment diagram – Parasite prestressing

## 10 Ultimate limit state (ULS)

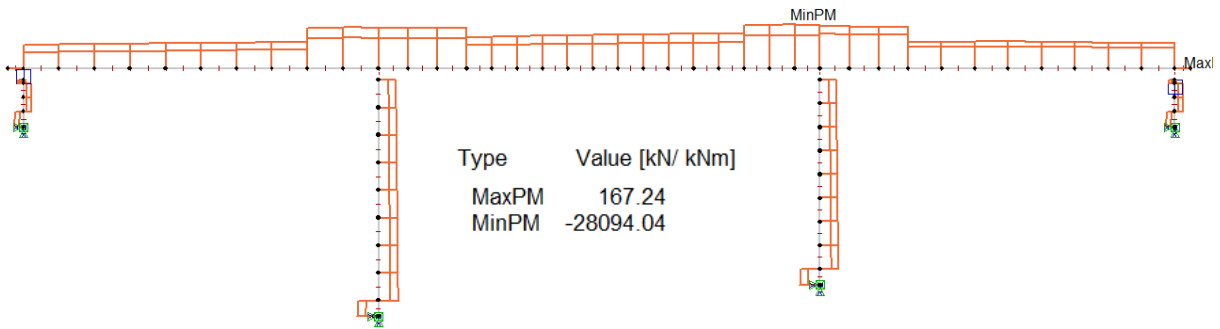

Figure 71 Axial force diagram – Full prestressing

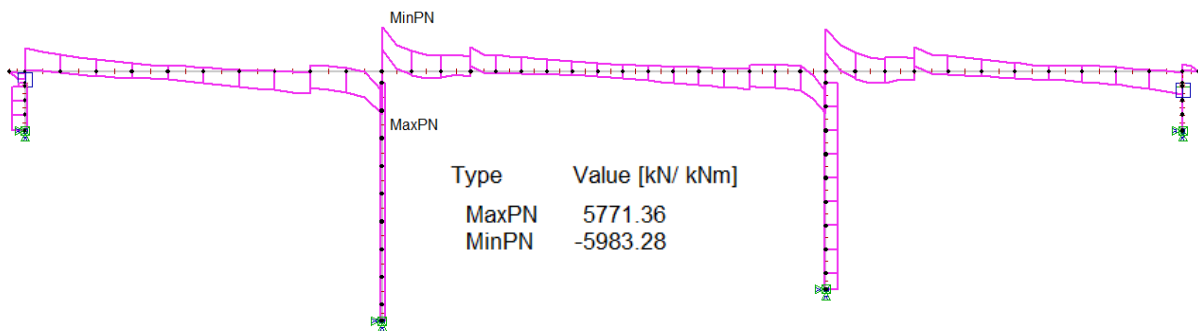

Figure 72 Shear force diagram – Full prestressing

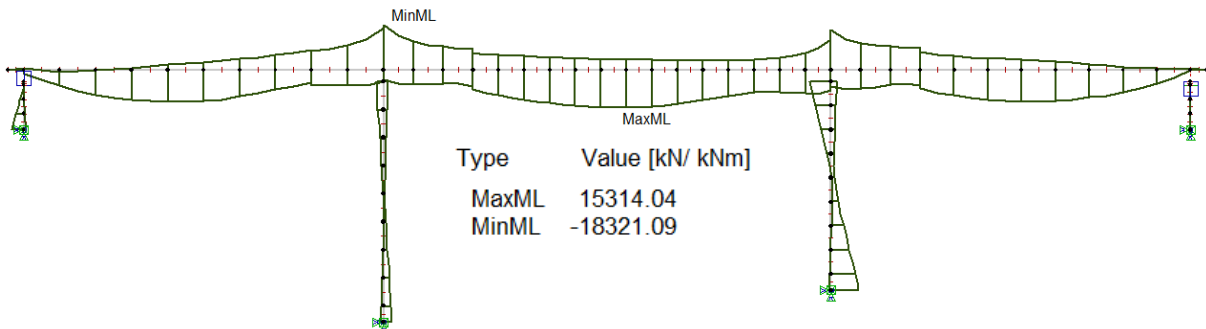

Figure 73 Bending moment diagram – Full prestressing

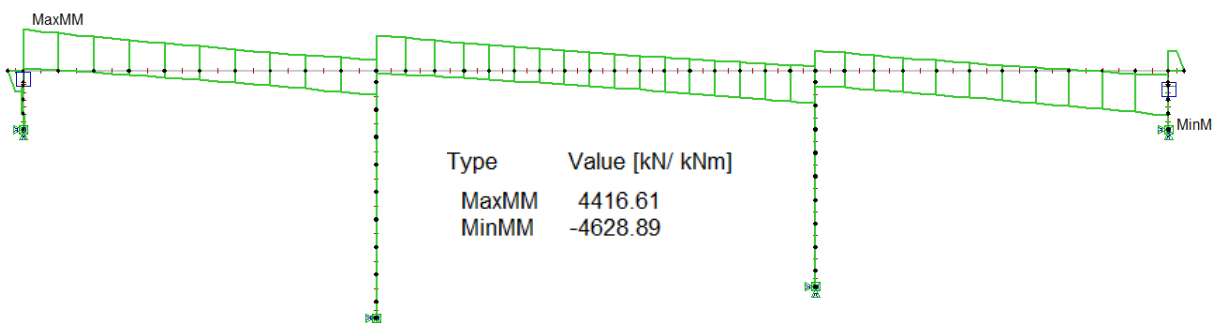

Figure 74 Torsional moment diagram – Full prestressing

### 10.2.2. Transverse direction

The purpose of this calculation is to find design values for bending moment and shear force between the flange and the web. The load in transverse direction contains:

- Self-weight:
- Self-weight – other
- Load model 1 or load model 2

The wind load was neglected and will not be used in the calculations. The calculations for the load models are made in the program Scia Engineer.

#### Self-weight

The self-weight of the flange is considered as a uniform load

$$M_E = 1,75m * 0,35m * 1m * 25 \text{ kN/m}^2 * \frac{1,75m}{2} = 13,4 \text{ kNm}$$

$$V_E = 1,75m * 0,35m * 1m * 25 \text{ kN/m}^2 = 15,3 \text{ kN}$$

#### Self-weight - other:

The sum of the other self-weight is  $40 \text{ kN/m}$  for  $8,5 \text{ m}$  width. The width of the web is  $1,75 \text{ m}$  thus the uniform load is  $\frac{40 \text{ kN/m}}{8,5m} = 4,7 \text{ kN/m}$ .

$$M_E = 1,75m * 1m * \frac{40 \text{ kN/m}}{8,5m} * \frac{1,75m}{2} = 7,2 \text{ kNm}$$

$$V_E = 1,75m * \frac{40 \text{ kN/m}}{8,5m} = 8,4 \text{ kN}$$

#### Load model 1

The wheel force cannot be assumed as a single vertical force. The wheel force is therefore represent by a uniform load. For load model 1 the size of the surface with contact with the wheel is  $0,4 \text{ m} * 0,4 \text{ m}$ .

The UDL system load is modelled as a uniform load for the first notional line, thus the uniform load is  $5,4 \text{ kN/m}$

LM 1 one wheel load:

$$\frac{150 \text{ kN}}{0,4 \text{ m} * 0,4 \text{ m}} = 938 \text{ kN/m}^2$$

$$\frac{100 \text{ kN}}{0,4 \text{ m} * 0,4 \text{ m}} = 625 \text{ kN/m}^2$$

## 10 Ultimate limit state (ULS)

The position of every wheel in transverse direction is shown in Figure 75. The bending moment from the tandem system is shown in Figure 76. The bending moment from UDL system is shown in Figure 77

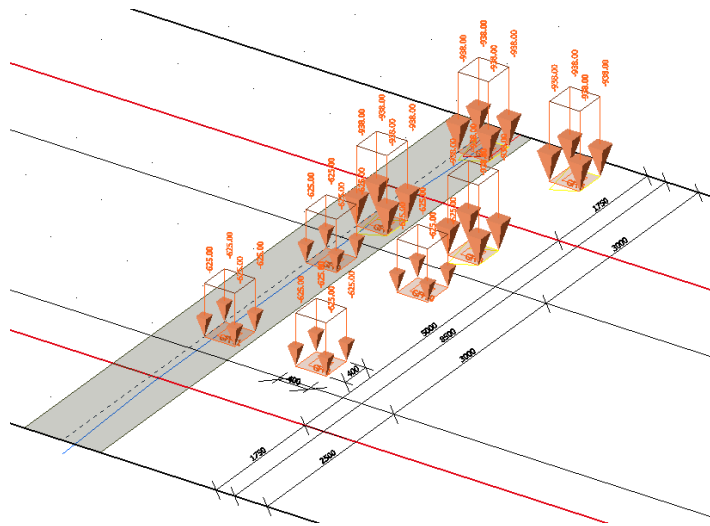

Figure 75 Position of Tandem system - LM1

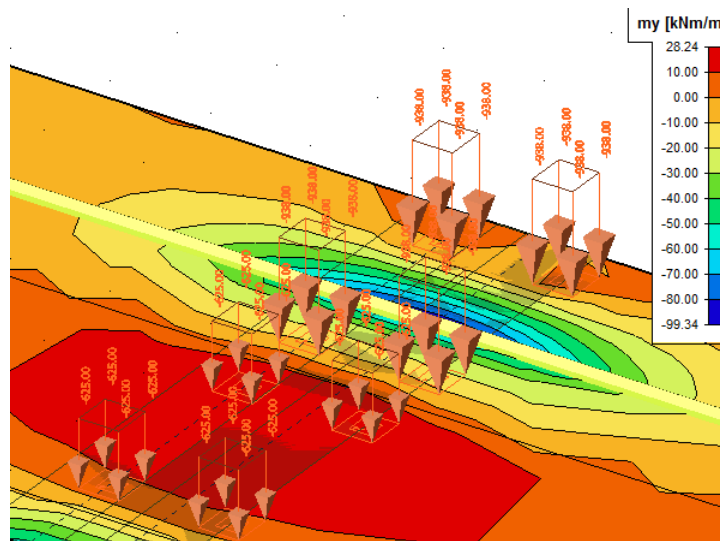

Figure 76 Bending moment - Tandem system load LM1



## 10 Ultimate limit state (ULS)

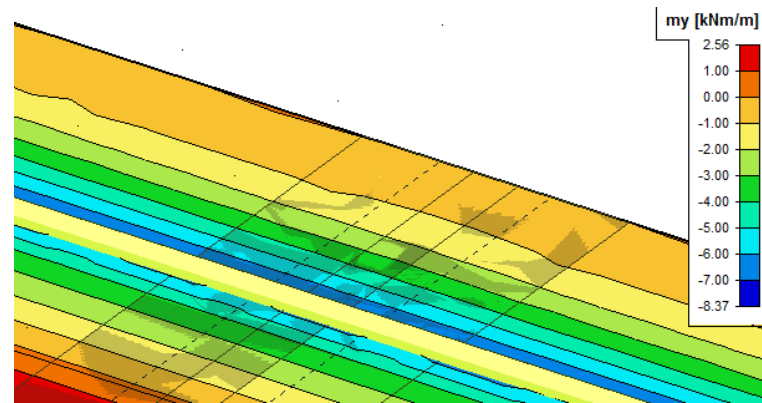

Figure 77 Bending moment – UDL system LM1

The summary of design values for self-weight and load model 1 are shown in Table 10.3.

Table 10.3 Maximum bending moment and shear force from self-weight

	Self-weight Uniform load	Self-weight other Uniform load
$M_{Ed}$	13,4 kNm	7,2 kNm
$V_{Ed}$	15,3 kN	8,4 kN

Table 10.4 Maximum bending moment and shear force from load model 1

	LM1 Uniform load	LM1 Tandem system load	Total for LM1
$M_{Ed}$	8,4 kNm	99 kNm	107,4 kNm
$V_{Ed}$	9,5 kN	110 kN	125,1 kN

### Load model 2

For load model 2 the size of the surface in contact with the wheel is 0,6 m\*0,35 m . LM 2 one wheel load as a uniform load:

$$\frac{200 \text{ kN}}{0,6 \text{ m} \cdot 0,35 \text{ m}} = 953 \text{ kN/m}^2$$

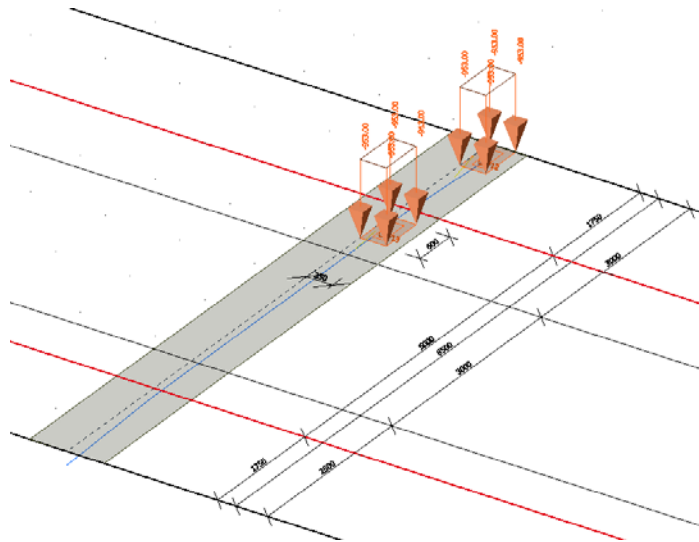

Figure 78 Position of LM2

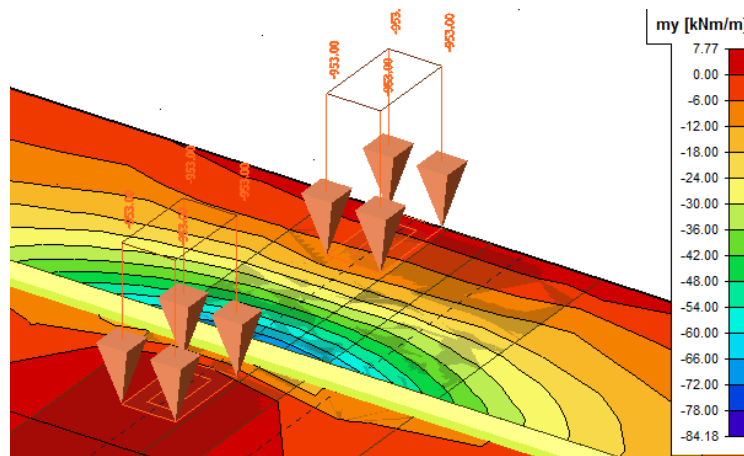

Figure 79 Bending moment - LM2

Table 10.5 Maximum bending moment and shear force from load model 2

Single axle load	
$M_{Ed}$	84 kNm
$V_{Ed}$	89 kN

## 10 Ultimate limit state (ULS)

The results of load model 2 from Figure 79 show that the bending moment and shear forces are smaller than the results of load model 1 from Table 10.4. Load model 1 is used for design values in the transvers direction.

### **The maximum design values in the transverse direction**

The design combination for ULS with dominant traffic load

$$M_{Ed,tra} = 1,2 * (13,4 + 7,2) + 1,35 * 107,4 = 169,8 \text{ kNm}$$

$$V_{Ed,tra} = 1,2 * (15,3 + 8,4) + 1,35 * 125,1 = 197,4 \text{ kN}$$

### 10.3. Moment capacity

A prestressed member usually remains uncracked under service loads. The analysis under service loads assumes the material to be linear elastic. After cracking, the behaviour of a prestressed member is similar to a non-prestressed reinforced concrete member. With increasing load, the stress versus strain behaviour of concrete becomes non-linear. Close to the yielding of the prestressing steel, the stress versus strain behaviour of steel also becomes non-linear.

The analysis of a prestressed member for ultimate strength is similar to that of a reinforced concrete member. The analysis aims to calculate the ultimate moment capacity (ultimate moment of resistance). The capacity is compared with the demand at ultimate loads.

The maximum strain value of concrete,  $\varepsilon_{cu}$ , is 0.0035. This strain is the average maximum that concrete of all grades can withstand before crushing of the material occur.

By the time the limiting concrete strain has been reached, the total strain in the prestressing steel,  $\varepsilon_p$ , can either be:

- greater than  $\varepsilon_{pk}$ , in which case the steel will have yielded before the concrete finally crushes—a ductile failure (such a section is termed under-reinforced);
- less than  $\varepsilon_{pk}$ , in which case the steel will not have yielded before the concrete finally crushes—a brittle failure (such a section is termed over-reinforced). If the steel strain equals  $\varepsilon_{pk}$ , then the section is assumed to be balanced.

$$\alpha_b := \frac{\varepsilon_{cu}}{\frac{f_{pd}}{E_p} + -\varepsilon'_{p0} + \varepsilon_{cu}} = 0.634$$

In all cases the cross-sections are under-reinforced and they are calculated without steel reinforcement, due to find the minimum resistance moment. The diagrams in Figure 69 is basic for calculating moment capacities in the span and over the support.

The design values are collected from NovaFrame and correspond to Figure 69.

The complete calculations are shown in Appendix O

### 10.3.1. Over the support

The width of the cross section is assumed by the width of the web  $b_{web} = 5$  m. The reason for that is that the web lays in the compression zone, then the cross section is assumed as a rectangular cross-section.

$$A_{pb.sup} := 0.8 \cdot \frac{f_{cd}}{f_{pd}} \cdot \alpha_b \cdot b_{web} \cdot d_{sup} = 44949 \text{ mm}^2$$

$$A_{p.sup} := n_{sup} \cdot A_{cable} = 22500 \text{ mm}^2$$

$$M_{Rd.sup} := 0.8 \cdot \alpha_{sup} \cdot (1 - 0.4 \cdot \alpha_{sup}) \cdot f_{cd} \cdot b_{web} \cdot d_{sup}^2$$

$$M_{Rd.sup} = 35747 \text{ kNm}$$

$$M_{Ed.sup} = 26342 \text{ kNm}$$

### 10.3.2. Middle span

The width of the cross section is assumed by the effective width of the flange  $b_{eff} = 8,5$  m. The thickness of the flange is assumed thick if  $t \geq \lambda \alpha d$  and then the calculation is the same as for a rectangular cross-section [13]. The requirement is fulfilled and the moment resistance shows that it is greater than the design value.

$$M_{Rd.span2} := 0.8 \cdot \alpha_{span.2} \cdot (1 - 0.4 \cdot \alpha_{span.2}) \cdot f_{cd} \cdot b_{eff} \cdot d_{span2}^2$$

$$M_{Rd.span.m} = 31325 \text{ kNm}$$

$$M_{Ed.span.m} = 25571 \text{ kNm}$$

### 10.3.3. Side span

The flange is assumed thick and then the calculation is the same as for the middle span.

$$M_{Rd.span1} := 0.8 \cdot \alpha_{span.1} \cdot (1 - 0.4 \cdot \alpha_{span.1}) \cdot f_{cd} \cdot b_{eff} \cdot d_{span1}^2$$

$$M_{Rd.span.s} = 24010 \text{ kNm}$$

$$M_{Ed.span.s} = 20813 \text{ kNm}$$

**10.3.4. Transverse direction**

The width of the slab is assumed to be 1 m. The prestressing force is not assumed. The design bending moment is obtained from 10.2.2. Calculation is shown in Appendix O

$$M_{Rd,tra} := 0.8 \cdot \alpha_{tra} \cdot (1 - 0.4 \cdot \alpha_{tra}) \cdot f_{cd} \cdot b_{tra} \cdot d_{tra}^2$$

$$M_{Rd,tra} = 219 \text{ kNm}$$

$$M_{Ed,tra} = 169,8 \text{ kNm}$$

## 10.4. Shear capacity

The objective of the design is to provide an ultimate resistance for shear  $V_{Rd}$  greater than the shear demand under ultimate loads  $V_{Ed}$ .

### 10.4.1. Over the support

The design values of shear force are collected from the ULS combination with full prestressing also shown in Figure 72.

The calculation is provided in distance  $d$  from the support in axis 2 according to EN 1992, section 6.2. First check for Members not requiring design shear reinforcement (EN 1992, section 6.2.2) show that the concrete deck does not need to be reinforced. The calculation showed that it has to be calculated with minimal longitudinal reinforcement (25  $\phi$ 25mm). Shear resistance without longitudinal reinforcement  $V_{Rd.c} = 5502 \text{ kN}$

$$V_{Ed} = 5742 \text{ kN}$$

Shear resistance without shear reinforcement, but with longitudinal minimal reinforcement

$$V_{Rd.c} := \left( C_{Rd.c} \cdot k \cdot \left( 100 \cdot \rho_1 \cdot \frac{f_{ck}}{\text{MPa}} \right)^{\frac{1}{3}} \cdot \text{MPa} + k_1 \cdot \sigma_{cp} \right) \cdot b_{web} \cdot d_{sh}$$

$$V_{Rd.c} = 5900 \text{ kN}$$

The complete calculation in Appendix O

### 10.4.2. Transverse direction

The shear in transverse direction is calculated according to EN 1992 6.2.2.

The transverse cables are within a distance of 500 mm. The prestressing losses are expected to be 15 %. The cross-section is assumed under-reinforced.

The design shear force  $V_{Ed} = 197.4 \text{ kN}$

Shear resistance without the reinforcement.

$$V_{Rd.c} := \left( C_{Rd.c} \cdot k \cdot \left( 100 \cdot \rho_1 \cdot \frac{f_{ck}}{\text{MPa}} \right)^{\frac{1}{3}} \cdot \text{MPa} + k_1 \cdot \sigma_{cp} \right) \cdot 1 \text{ m} \cdot d_{tra}$$

$$V_{Rd.c} = 202 \text{ kN}$$

### 10.4.3. Construction joints

Shear at the interface between concrete cast at different times. This will happen in element 240. 8 cables are placed through this element.

Forces in element 240:  $V_{Ed} = 3829$  kN,  $N_{Ed} = 19747$  kN therefore the shear stress in the joint is:

$$v_{Ed,i} = 0,45 \text{ MPa}$$

The shear resistance at the joint

$$V_{Rd,i} := c \cdot f_{ctd} + \mu \cdot \sigma_n + \rho \cdot f_{yd} \cdot \mu$$

$$V_{Rd,i} = 2,478 \text{ MPa}$$

## 10.5. Torsion capacity

For simplification only a rectangular cross-section is assumed (see Figure 80).

The design torsional moment is:

$$T_{Ed} = 4628 \text{ kNm}$$

The maximum resistance of a member subjected to torsion and shear is limited by the capacity of the concrete struts. The following condition should be satisfied:

$$\frac{T_{Ed}}{T_{Rd,max}} + \frac{V_{Ed}}{V_{Rd,max}} = 0.357 \quad 0.357 \leq 1$$

Another requirement is that if the following condition exceed 1, there has to be an additional torsion reinforcement

$$\frac{T_{Ed}}{T_{Rd,c}} = 0.834 \quad 0.834 \leq 1$$

So there is only the requirement for minimum reinforcement without extra torsional reinforcement.

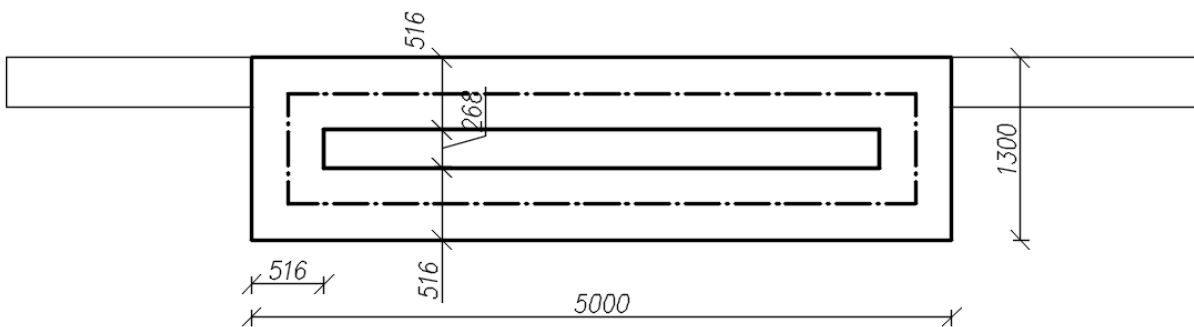

Figure 80 Simplified cross-section for torsion resistance



## 11 SERVICEABILITY LIMIT STATES (SLS)

The common serviceability limit states according to EN 1992 are:

- stress limitation
- crack control
- deflection control (not controlled in this master's thesis)

### 11.1. General

Concrete cross-sections can behave in 2 stages:

1<sup>st</sup> stage of stress-strain behaviour - Stresses elastic and section uncracked

2<sup>nd</sup> stage of stress-strain behaviour - Stresses elastic and section cracked

1<sup>st</sup> stage – uncracked

If the maximum tension stress in a concrete cross-section is less than the mean value of axial tensile strength  $f_{ctm}$  the cross-section remains uncracked. The entire concrete cross-section is assumed for the stiffness and the concrete cross-section has a tension and compression capacity as shown in Figure 81

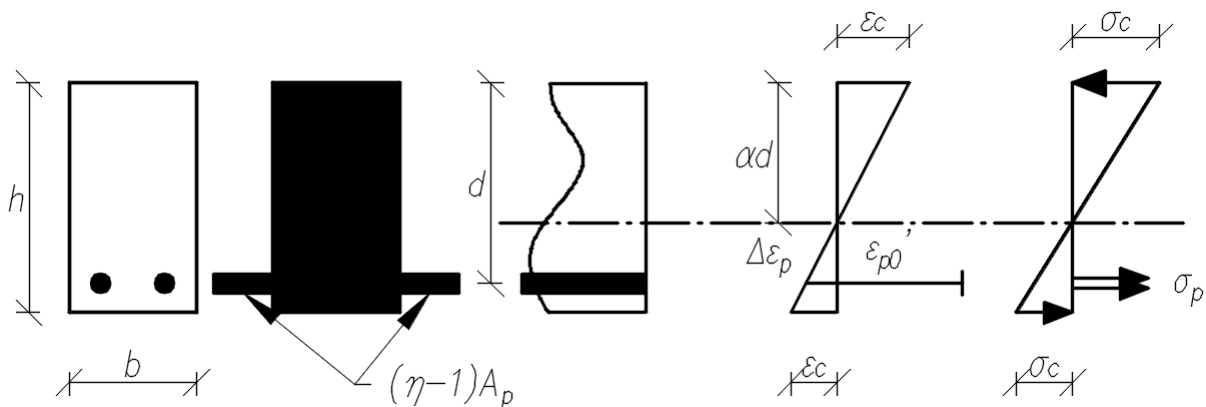

Figure 81 1<sup>st</sup> stage of stress-strain behaviour - section uncracked

The stress in concrete calculates as shown below:

$$\sigma_c = -\frac{P_0}{A_t} - \frac{M_t^*(y-y_t)}{I_t}$$

2<sup>nd</sup> stage – cracked

If the maximum tension stress in a concrete cross-section is greater than the mean value of axial tensile strength  $f_{ctm}$ , cracks will appear in the tension part of the cross-section. Only the height of concrete the cross-section in compression is assumed for the stiffness and the concrete cross-section has a tension and compression capacity as shown in Figure 82

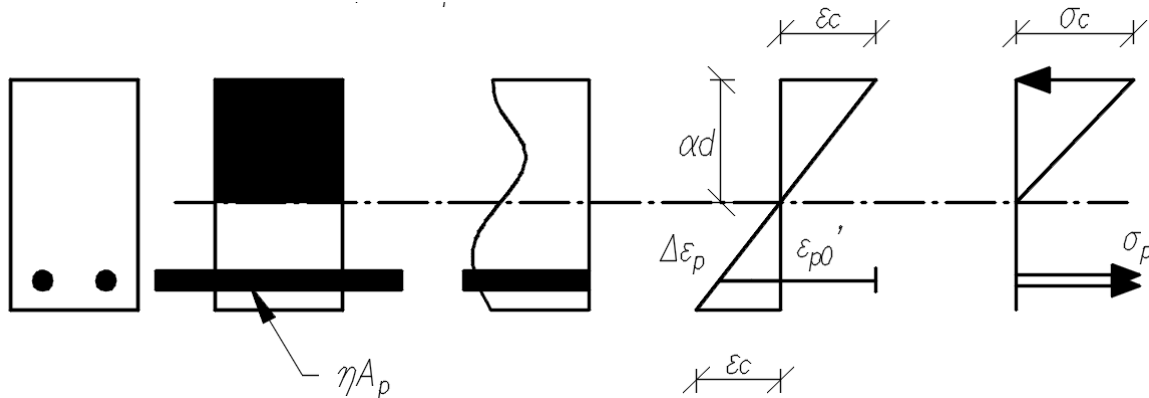

Figure 82 2<sup>nd</sup> stage of stress-strain behaviour - section cracked

The stress in concrete calculates from force and moment equilibrium as shown below

$$\sigma_{cA} = \frac{N}{bd} - \frac{1}{\frac{1}{2} * \alpha - \eta * \rho * \frac{1 - \alpha}{\alpha}}$$

$$\sigma_{cM} = \frac{N}{bd} - \frac{2 * (e + a)}{d} * \frac{1}{\alpha * \left(\frac{1 - \alpha}{3}\right)}$$

The results from these equilibrium are plotted into a chart, therefore  $\alpha$  and  $\sigma_c$  are obtained

## 11.2. Analysis results

The design diagrams for serviceability limit state are provided by NovaFrame. The results are further used for calculations of stress limitations and crack control.

### 11.2.1. *Longitudinal direction*

The following diagrams are presented:

- axial force
- shear force
- bending moment
- torsional moment

for every load combinations such as:

- Characteristic combination
- Frequent combination
- Quasi-permanent combination

The diagrams are presented the in Figure 83 to Figure 94.

11 Serviceability limit states (SLS)

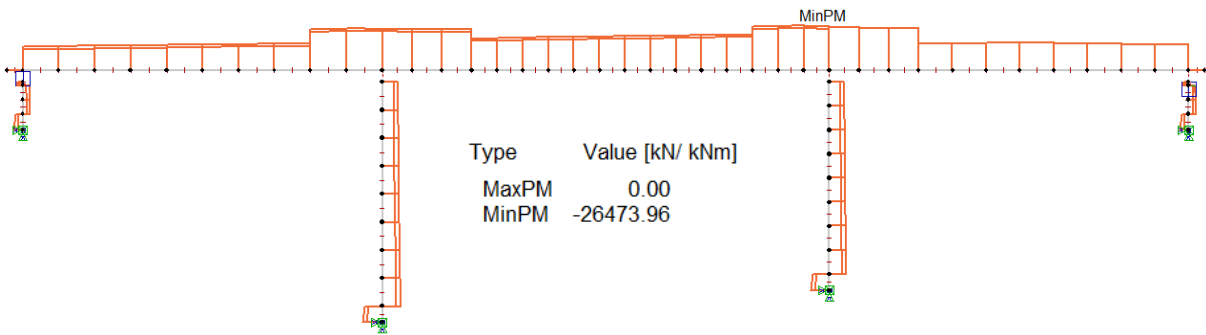

Figure 83 Axial force diagram - Characteristic combination

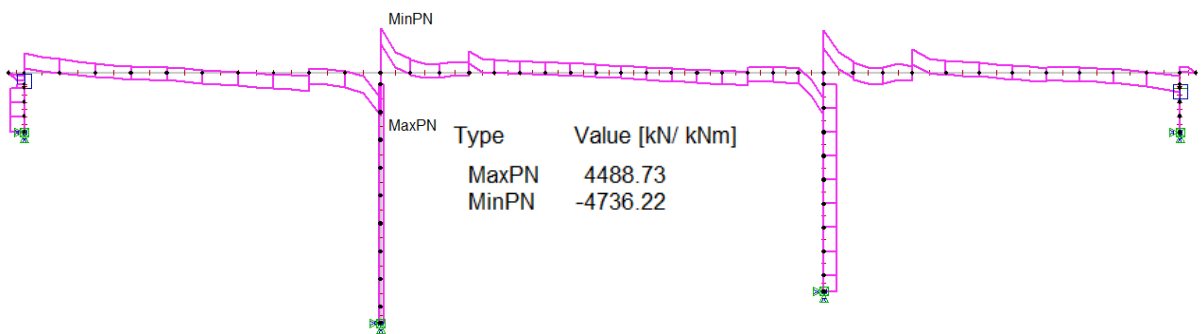

Figure 84 Shear force diagram - Characteristic combination

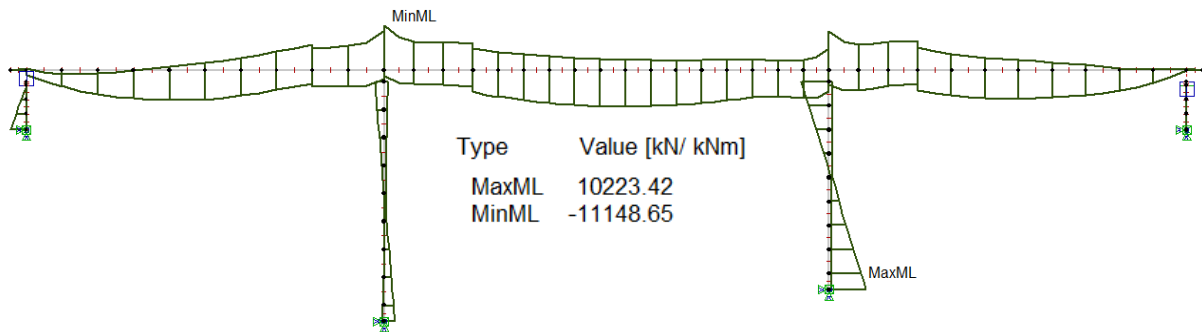

Figure 85 Bending moment diagram - Characteristic combination

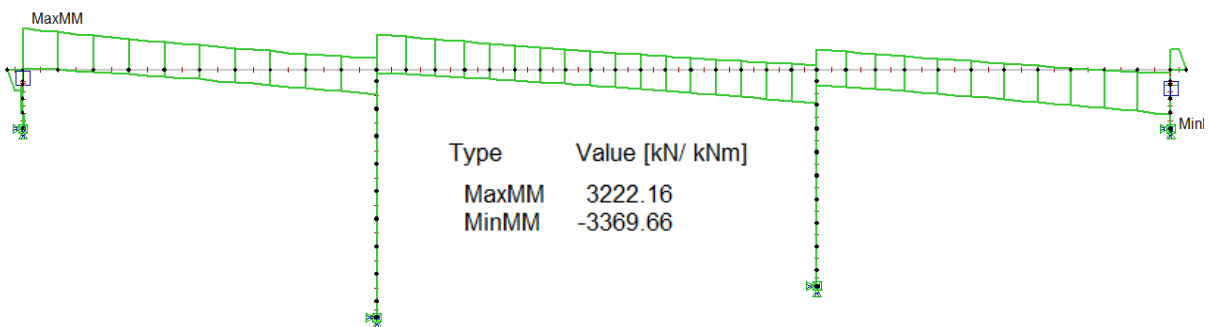

Figure 86 Torsional moment diagram - Characteristic combination

11 Serviceability limit states (SLS)

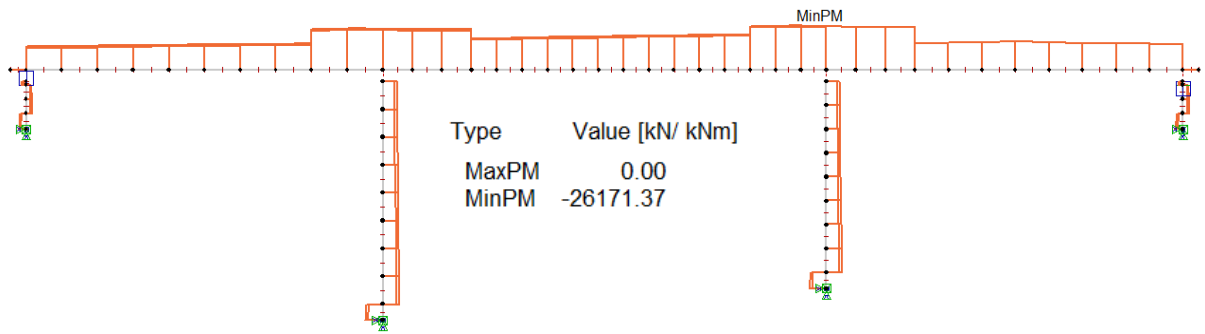

Figure 87 Axial force diagram - Frequent combination

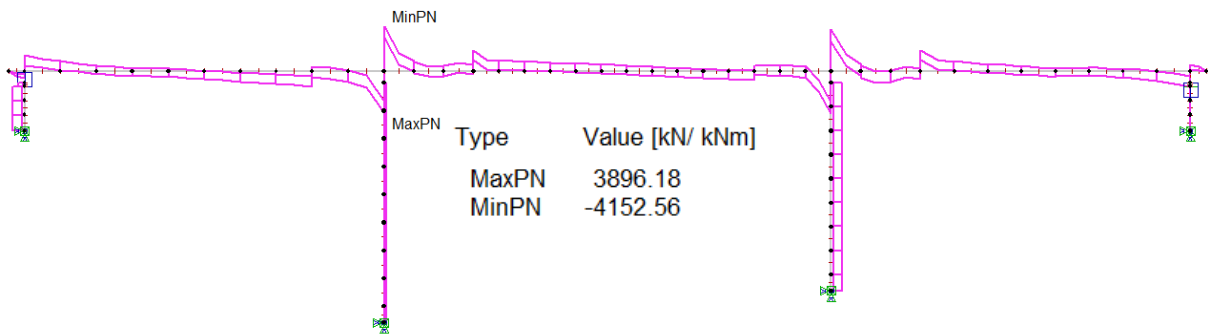

Figure 88 Shear force diagram - Frequent combination

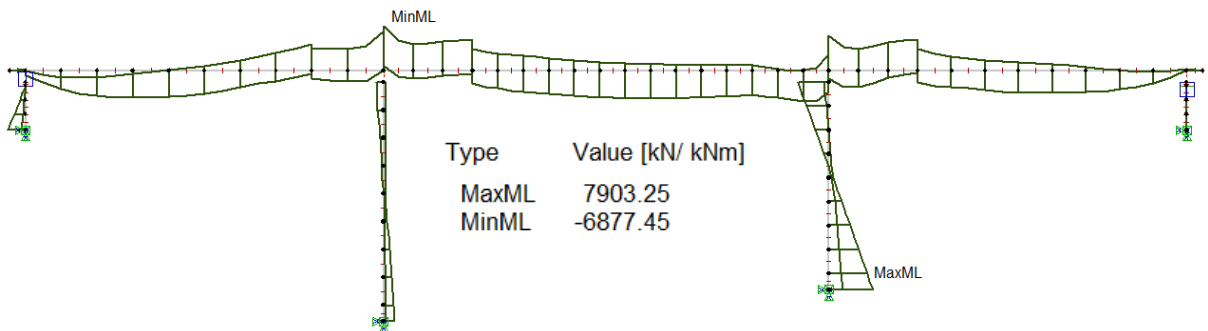

Figure 89 Bending moment diagram - Frequent combination

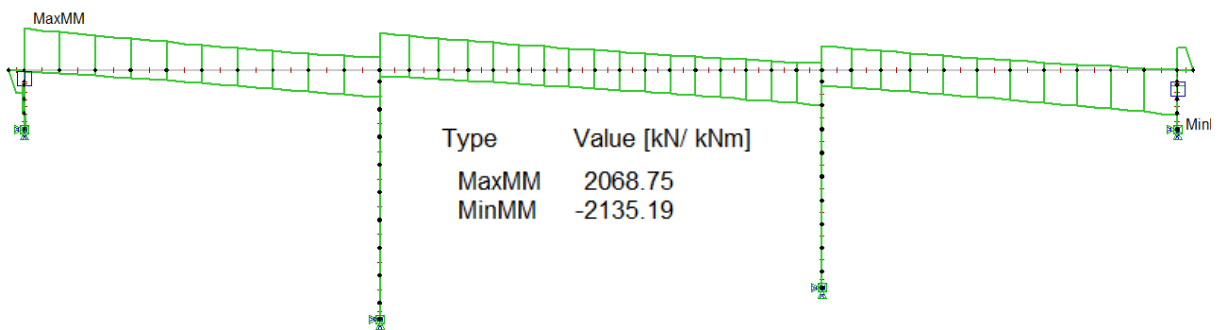

Figure 90 Torsional moment diagram - Frequent combination

## 11 Serviceability limit states (SLS)

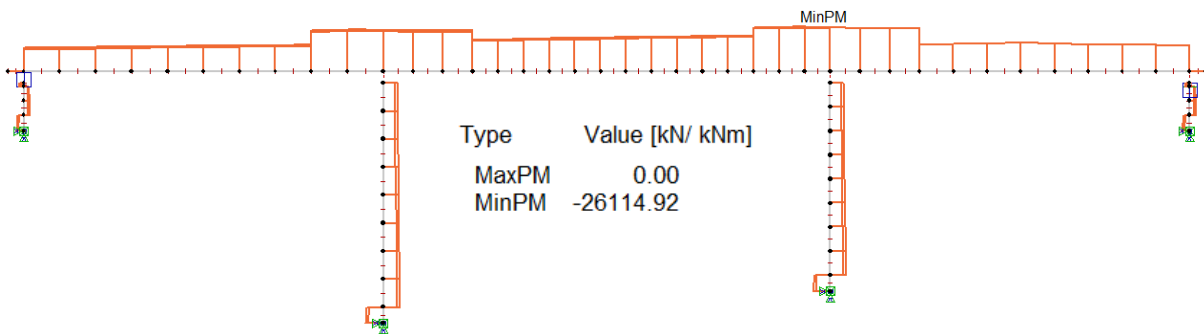

Figure 91 Axial force diagram - Quasi-permanent combination

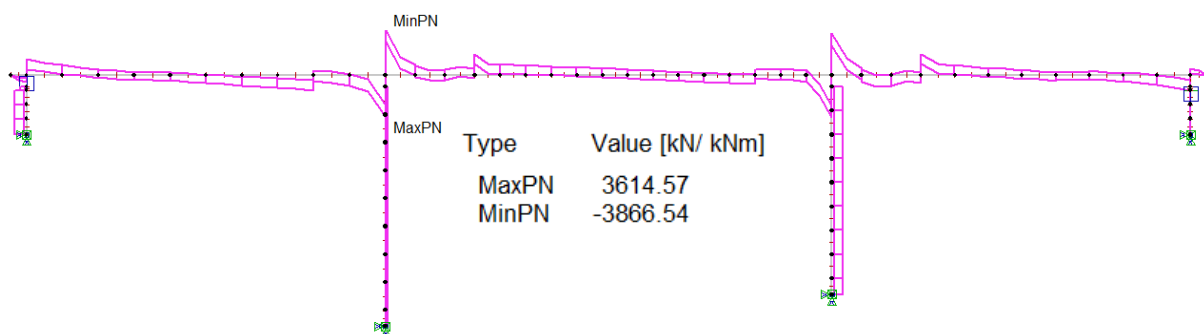

Figure 92 Shear force diagram - Quasi-permanent combination

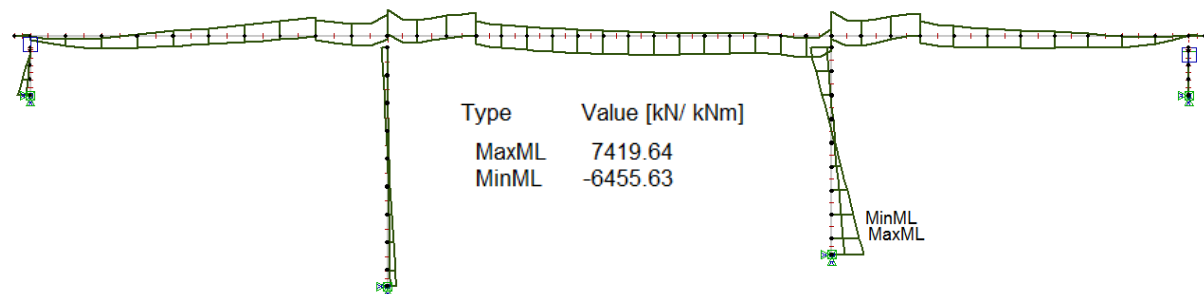

Figure 93 Bending moment diagram - Quasi-permanent combination

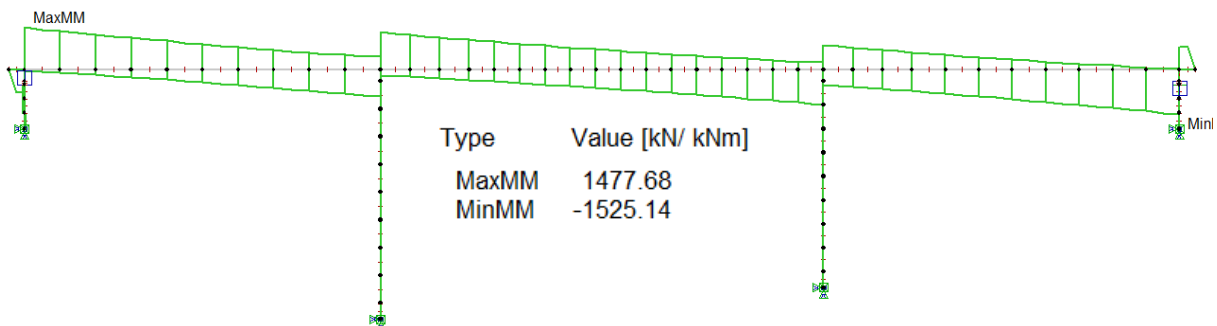

Figure 94 Torsional moment diagram - Quasi-permanent combination

### 11.2.2. Transverse direction

The prestressing cables in the transverse direction are spaced evenly at a distance of 0,5 m. The anchorages on the both ends are places in a neutral axis. The eccentricity of the cable in the section between flange and web is 75 mm. The prestressing losses are assumed as 15% of maximal prestressing force.

Axial force and bending moment due to the transverse prestressing are collected from Appendix P and the values correspond to the values from Scia Engineer as shown in Figure 95. The results are shown below:

$$N_{Ed}=691,2 \text{ kN}$$

$$M_{Ed}=-50,6 \text{ kNm}$$

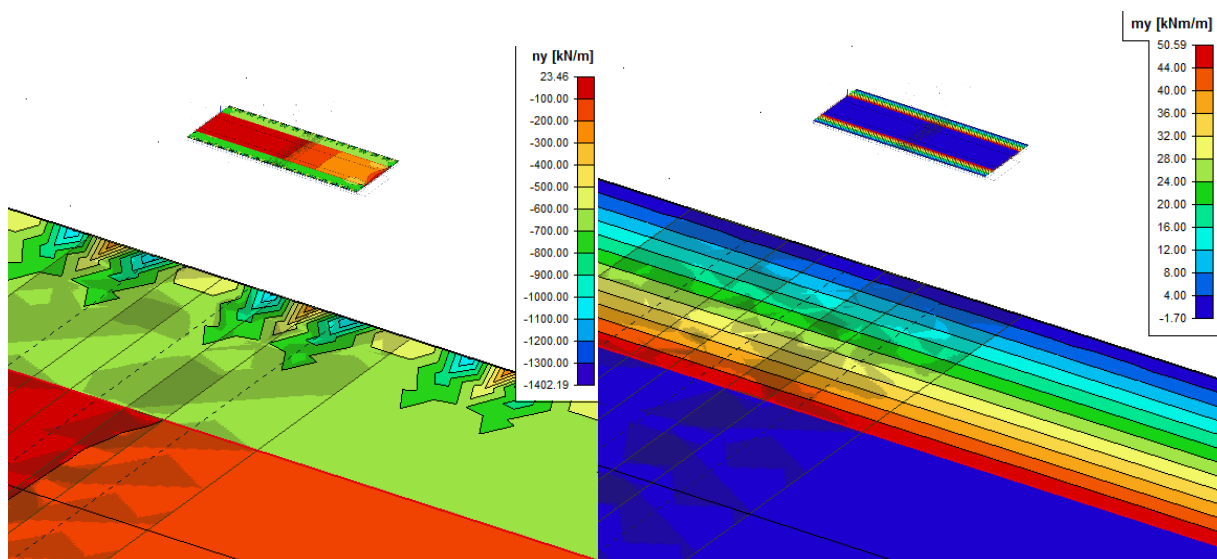

Figure 95 Maximal axial force and bending moment from transverse prestressing

The design values are calculated according to SLS load combinations (Table 7.8) and the values are collected from chapter 0.

Characteristic combination – without prestressing

$$M_{Ed}=1,0*(13,4+7,2)+1,0*107,4=128,0 \text{ kNm}$$

$$V_{Ed}=1,0*(15,3+8,4)+1,0*125,1=148,8 \text{ kN}$$

Frequent combination– without prestressing

$$M_{Ed}=1,0*(13,4+7,2)+0,7*107,4=95,8 \text{ kNm}$$

$$V_{Ed}=1,0*(15,3+8,4)+0,7*125,1=111,3 \text{ kN}$$

Quasi-permanent combination– without prestressing

$$M_{Ed}=1,0*(13,4+7,2)+0,5*107,4=74,3 \text{ kNm}$$

$$V_{Ed}=1,0*(15,3+8,4)+0,5*125,1=86,3 \text{ kN}$$

### 11.3. Stress limitations

The requirements for stress limitations are:

The compressive stress under the characteristic combination in the concrete shall be limited.  $k_1 = 0,6$  according to EN 1992-1-1 section NA.7.2(2)

$$\sigma_{c.char.comb} \leq k_1 * f_{ck} = 0,6 * 45 \text{ MPa} = 27 \text{ MPa}$$

The compressive stress under the quasi-permanent combination in the concrete shall be limited.  $k_2 = 0,45$  according to EN 1992-1-1 section NA.7.2(3)

$$\sigma_{c.quasi.comb} \leq k_2 * f_{ck} = 0,45 * 45 \text{ MPa} = 20,25 \text{ MPa}$$

Tensile stresses in the reinforcement under the characteristic combination of loads shall be limited.  $k_3 = 0,8$  according to EN 1992-1-1 section NA.7.2(5)

$$\sigma_{s.char.comb} \leq k_3 * f_{yk} = 0,8 * 500 \text{ MPa} = 400 \text{ MPa}$$

Tensile stresses in the reinforcement are caused by imposed deformation, the tensile stress should not exceed

$$\sigma_{s.def} \leq k_4 * f_{yk} = 1,0 * 500 \text{ MPa} = 500 \text{ MPa}$$

The mean value of the stress in prestressing tendons should not exceed

$$\sigma_{p.mean} \leq k_5 * f_{pk} = 0,75 * 1860 \text{ MPa} = 1395 \text{ MPa}$$

A concrete cross-section remain uncracked if the stress in concrete is lower than  $f_{ct,eff} = f_{ctm} 3,8 \text{ MPa}$ . The stress limitation calculations assume the long-term modulus of elasticity  $E_{cm} = 13390 \text{ MPa}$ , which will provide the maximum stresses in the cross-section results after 100 years.

Calculation of stresses is according to [13]. The resulting stresses from Appendix P in the concrete cross-section are shown in

Table 11.1

Table 11.1 Stresses in concrete

	Surface	Stress in concrete [MPa]		
		Char.	Freq.	Quasi
Over support	Top	3,3	1,1	0,7
	Bottom	-10,7	-8,0	-7,6
Middle span	Top	-7,0	-4,7	-4,4
	Bottom	3,8	0,4	0,1
Side span	Top	-5,5	-4,0	-3,8
	Bottom	3,1	1,1	0,5
Transverse	Top	1,4	-0,2	-1,2
	Bottom	-5,4	-3,8	-2,8



## 11 Serviceability limit states (SLS)

## 11.3.1. Longitudinal direction

The results in

Table 11.1 show that the maximum concrete cross-section stresses in tension does not exceed the maximum mean value of axial tensile strength  $f_{ctm}$ . Than it is assumed that the concrete cross-section remains in 1<sup>st</sup> stage – uncracked.

The stress limitations are calculated in Appendix P and the results are shown in Table 11.2 and Table 11.3

Table 11.2 Stress limitations over the support

Over support					
			Char.	Quasi	
<b>Concrete</b>	$\sigma_{c.char} \leq 0,6 * f_{ck}$	27 MPa	10,7 MPa	-	OK
<b>Concrete</b>	$\sigma_{c.quasi} \leq 0,45 * f_{ck}$	20,25 MPa	-	7,6 MPa	OK
<b>Reinforcement</b>	$\sigma_{s.char} \leq 0,8 * f_{yk}$	400 MPa	33 MPa	-	OK
<b>Prestressing</b>	$\sigma_{p.mean} \leq 0,75 * f_{pk}$	1395 MPa	1226 MPa	-	OK

Table 11.3 Stress limitations in the side span

In side span					
			Char.	Quasi	
<b>Concrete</b>	$\sigma_{c.char} \leq 0,6 * f_{ck}$	27 MPa	5,5 MPa	-	OK
<b>Concrete</b>	$\sigma_{c.quasi} \leq 0,45 * f_{ck}$	20,25 MPa	-	3,8 MPa	OK
<b>Reinforcement</b>	$\sigma_{s.char} \leq 0,8 * f_{yk}$	400 MPa	23 MPa	-	OK
<b>Prestressing</b>	$\sigma_{p.mean} \leq 0,75 * f_{pk}$	1395 MPa	1216 MPa	-	OK

The results in Table 11.2 and Table 11.3 show that the stress limitation requirements are fulfil.

### 11.3.2. Transverse direction

Stress limitations are calculated in Appendix P and the results are shown in Table 11.4.

Table 11.4 Stress limitations in the transverse direction

Transverse direction					
			Char.	Quasi	
<b>Concrete</b>	$\sigma_{c.char} \leq 0,6 \cdot f_{ck}$	27 MPa	5,4 MPa	-	OK
<b>Concrete</b>	$\sigma_{c.quasi} \leq 0,45 \cdot f_{ck}$	20,25 MPa	-	2,8 MPa	OK
<b>Reinforcement</b>	$\sigma_{s.char} \leq 0,8 \cdot f_{yk}$	400 MPa	-	-	OK
<b>Prestressing</b>	$\sigma_{p.mean} \leq 0,75 \cdot f_{pk}$	1395 MPa	1296 MPa	-	OK

The results in Table 11.4 show that the stress limitation requirements are fulfilled.

## 11.4. Crack control

Cracks develop in a concrete cross-section if a tensile stress excess the maximum mean value of axial tensile strength  $f_{ctm}$ . In this master's thesis the tensile strength,  $f_{ctm} = 3,8$  MPa.

The crack control depends on the exposure class of a surface. The top surface is within class XD1 and the bottom surface in class XC3.

Recommended values of maximum crack width are shown in Table 11.5. Coefficient  $k_c$  depends on size of concrete cover and is equal to 1,3.

Table 11.5 Recommended values of  $w_{max}$

Prestressed members with bonded tendons		
XC3 bottom surface	$0,2 * k_c = 0,26$ mm	Frequent load combination
XD1 top surface	$0,2 * k_c = 0,26$ mm	Frequent load combination
	Decompression	Quasi-permanent load combination
Reinforced members		
XC3 bottom surface	$0,3 * k_c = 0,39$ mm	Quasi-permanent load combination
XD1 top surface	$0,3 * k_c = 0,39$ mm	Quasi-permanent load combination

The results of concrete cross-section stresses in Table 11.1 show that all stresses don't exceed the maximum mean value of axial tensile strength  $f_{ctm}$ . Then we can assume that cracks won't develop and the cross-section stays uncracked.

The decompression limit requires that all parts of the bonded tendons or duct lie at least  $\Delta C_{dev} = 10$  mm within concrete in compression according to [19] 4.9.1

The requirement for decompression in quasi-permanent load combination is satisfied. The duct in longitudinal direction lays within concrete in compression 17 mm from the neutral axis as shown in Figure 96. The stress in the flange in transverse direction lays in the compression over the whole height of the cross-section.

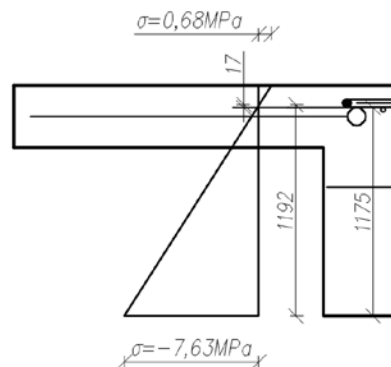

Figure 96 Stress distribution for quasi-permanent load combination over the support



## 12 CONCLUSION

This master's thesis covered topics from the design basis to the results for ultimate and serviceability limit states. During the process, position of cables, prestress losses, analytical model, verification of analytical model were assumed.

The design of prestressing steel meets all requirements such as minimal distance between ducts and anchorages, minimal distances from edge and concrete cover. The building process has been proposed

The analytical model has been created in the program NovaFrame. The process of creating the analytical model has been challenging and it has taken many hours to create a final model. Then the results from the analysis have been used in succeeding calculations.

The verifications have showed that the analytical model in NovaFrame works as expected. Thus it can be stated that the results from NovaFrame are correct and could be use in design process.

Design values have been controlled against their capacities in ultimate limit state (ULS). Moment, shear and torsion have been assumed. Moment and shear have been controlled in both directions. The results showed that they don't exceed the capacities. A summary of the results is shown in Table 12.1

Table 12.1 Summary of ULS

		Capacity	Design value	Utilization
<b>Moment [kNm]</b>	Over support	35747	26342	74 %
	Middle span	31325	25571	82 %
	Side span	24010	20813	85 %
	Transverse direction	219	169,8	78 %
<b>Shear [kN]</b>	Resistance without reinforcement	5900	5742	97 %
	Transverse direction	202	197,4	98 %
	Construction joint	2,5	0,45	18 %
<b>Shear [MPa]</b>	Maximum resistance	0,357	1,0	35 %
<b>Torsion [MPa]</b>	Torsional resistance	25818	4628	21 %
	Torsional cracking moment	5550	4628	84 %

The calculation of shear resistance without shear reinforcement imply that the minimal longitudinal reinforcement has to be placed or shear link has to be placed or more cables have to be added. The best solution is to add minimal longitudinal reinforcement.

The requirements for serviceability limit state have been met. The calculations showed that the concrete cross-section stays in stage I - uncracked and then cracks will not develop during all load combinations. The requirements for stress limitations and decompression for top surface has been met in both directions. A summary is shown in Table 12.2

Table 12.2 Summary of SLS

Over support – XD1						
Stress limitations - requirement			Char.	Freq.	Quasi	
Concrete	$\sigma_{c.char}$	27 MPa	10,7 MPa	-	-	OK
Concrete	$\sigma_{c.quasi}$	20,2 MPa	-	-	7,6 MPa	OK
Reinforcement	$\sigma_{s.char}$	400 MPa	33 MPa	-	-	OK
Prestressing	$\sigma_{p.mean}$	1395 MPa	1226 MPa	-	-	OK
Crack control	$w_{max}$	0,26 mm	-	no crack	-	OK
		decompression			decompression	OK
In side span – XC3						
Stress limitations - requirement			Char.	Freq.	Quasi	
Concrete	$\sigma_{c.char}$	27 MPa	5,5 MPa	-	-	OK
Concrete	$\sigma_{c.quasi}$	20,2 MPa	-	-	3,8 MPa	OK
Reinforcement	$\sigma_{s.char}$	400 MPa	23 MPa	-	-	OK
Prestressing	$\sigma_{p.mean}$	1395 MPa	1216 MPa	-	-	OK
Crack control	$w_{max}$	0,26 mm	-	no crack	-	OK
Transverse direction– XD1						
Stress limitations - requirement			Char.	Freq.	Quasi	
Concrete	$\sigma_{c.char}$	27 MPa	5,4 MPa	-	-	OK
Concrete	$\sigma_{c.quasi}$	20,2 MPa	-	-	2,8 MPa	OK
Reinforcement	$\sigma_{s.char}$	400 MPa	-	-	-	OK
Prestressing	$\sigma_{p.mean}$	1395 MPa	1296 MPa	-	-	OK
Crack control	$w_{max}$	0,26 mm	-	no crack	-	OK
		decompression	-	-	decompression	OK

The candidate has gotten a deep understanding for the design of structures and mainly a wide perspective in design of post-tensioned bridges. He has become familiar with standards and other legislations.

## 12.1. Further work

Further work of this master's thesis could be:

- Optimize concrete cross-section
- Capacity during the building stages
- Shear between web and flanges of T-sections
- Deflection control
- Transfer of prestress in anchorage regions
- Design of columns
- Design of foundation
- Design of bearings
- Design of expansion joint





## 13 REFERENCES

- [1] Standard Norge. (2008) *NS-EN 1990:2002+NA:2008 Eurocode: Basis of structural design* Brussel: CEN
- [2] Standard Norge. (2010) *NS-EN 1990:2002/A1:2005+NA:2010 Amendment A1 Eurocode: Basis of structural design*. Brussel: CEN
- [3] Standard Norge. (2008) *NS-EN 1991-1-1:2002+NA:2008 Eurocode 1: Actions on structures, Part 1-1: General actions Densities, self-weight, imposed loads for buildings*. Brussel: CEN
- [4] Standard Norge. (2009) *NS-EN 1991-1-4:2005+NA:2009 Eurocode 1: Actions on structures, Part 1-4: General actions, Wind actions*. Brussel: CEN; 2008
- [5] Standard Norge. (2008) *NS-EN 1991-1-5:2003+NA:2008 Eurocode 1: Actions on structures, Part 1-4: General actions, Thermal actions*. Brussel: CEN
- [6] Standard Norge. (2010) *NS-EN 1991-2:2003+NA:2010 Eurocode 1: Actions on structures, Part 2: Traffic loads on bridges*. Brussel: CEN
- [7] Standard Norge. (2008) *NS-EN 1992-1-1:2004+NA:2008 Eurocode 2: Design of concrete structures Part 1-1: General rules and rules for buildings*. Brussel: CEN
- [8] Standard Norge. (2010) *NS-EN 1992-2:2005+NA:2010 Eurocode 2: Design of concrete structures, Concrete bridges, Design and detailing rules*. Brussel: CEN
- [9] Statens vegvesen. (2015) *Håndbok N400: Bruprosjektering, Prosjektering av bærende konstruksjoner i det offentlige vegnettet*. Available at: <http://www.vegvesen.no/Fag/Teknologi/Bruer/Bru-handboker> (Accessed: 1 February 2015)
- [10] Hurst, M.K. (2003) *Prestressed Concrete Design*. London: Routledge 11 New Fetter Lane
- [11] Collins, M. and Mitchell, D.(1997) *Prestressed Concrete Structures*. Ontario: Response Publications
- [12] Navratil, J. (2004) *Predpjate betonove konstrukce*. Brno: Akademické nakladatelství CERM

- [13] Sørensen, S. I. (2011) *Betongkonstruksjoner, Beregning og dimensjonering etter Eurocode 2*. Trondheim: NTNU
- [14] Dywidag International Systems, *DYWIDAG Bonded Post-Tensioning Systems using strands*. Available at: <http://www.dywidag-norge.no/> (Accessed: 1 February 2015)
- [15] Dywidag International Systems, *ETA-06/0022 DYWIDAG Bonded Post - Tensioning System for 3 to 37 Strands (140 and 150 mm<sup>2</sup>)*. Available at: <http://www.dywidag-norge.no/> (Accessed: 1 February 2015).
- [16] Aas-Jakobsen.(2011) *User`s Guide - NovaFrame version 5*
- [17] Kaldbekkdalen, A-K. and Strand, E.H. (2014) *Prosjektering og analyse av en spennarmert betongbru*, (Master's thesis) Trondheim: NTNU
- [18] Bratland, M.L. (2013) *Beregningsmetoder for spennarmerte betongbruer*, (Master's Thesis) Trondheim: NTNU
- [19] Johansen, H. (2014) *Praktisk prosjektering av etteroppspente betongbruer* NTNU; Statens vegvesen Vegdirektoratet.
- [20] DYWIDAG-Systems International. (2011). Lahovice Bridge post-tensioned with DYWIDAG Strand Tendons - DYWIDAG-Systems International. [ONLINE] Available at: <http://www.dywidag-systems.com/emea/case-studies/reference-details/article/lahovice-bridge-near-prague-czech-republic.html>. (Accessed 01 June 15).
- [21] Dywidag International Systems, *ETA-13/0815 Bonded Post-Tensioning Kit for Prestressing of Structures with 3 to 55 Strands*. Available at: <http://www.dywidag-norge.no/> (Accessed: 1 February 2015).
- [22] VSL, *POST-TENSIONING SOLUTIONS*. Available at: <http://www.vsl.com/> (Accessed: 1 February 2015).
- [23] The Federal Highway Administration,(2013) *Post-Tensioning Tendon Installation and Grouting Manual* Available at: <http://www.fhwa.dot.gov/bridge/pt/> (Accessed: 1 February 2015).

## 14 LIST OF APPENDICES

Appendix A	Master's thesis tasks
Appendix B	Concrete strength properties
Appendix C	Minimum reinforcement
Appendix D	Concrete cover
Appendix E	Cable geometry
Appendix F	Wind load calculation
Appendix G	Creep and shrinkage strain
Appendix H	Creep loss
Appendix I	Verification of self-weight
Appendix J	Verification of wind load
Appendix K	Verification of temperature load
Appendix L	Verification of prestressing losses
Appendix M	Verification of prestressing losses - SCIA
Appendix N	Effective flange width
Appendix O	Ultimate limit state (ULS)
Appendix P	Serviceability limit states (SLS)



## Appendix A

KT6003 Prosjektering av bruer 1 høsten 2014

# Prosjektoppgave

## Innledning

Ei planlagt plasstøpt og etteroppspent bjelke/platebru skal analyseres og dimensjoneres i henhold til gjeldende regelverk. Brulengden er  $1,0 + 22,5 + 28,0 + 22,5 + 1,0 = 75,0$  meter (1,0 meter utstikk forbi landkaraksene på begge ender). Tverrsnittet er konstant, med føringsbredde 8,5 meter, bjelkedel bredde 5,0 meter, tverrsnittshøyde i bjelkedelen 1,3 meter og vingetykkelse 0,35 meter. Spennarmeringen er satt sammen av to kabelgrupper med 6 stk 15-taus kabler i hver gruppe. Lengdesnitt og tverrsnitt med spennkabler i endefelt og ved opplegg er vist i vedlagte figur. Antatt/foreslått kabelføring er også vist.

## Forutsetninger

### Utførelse

Overbygningen forutsettes utført i én støp med forskaling på reis fra bakken.

De som ønsker (frivillig), kan regne med følgende tre byggefaser:

1. Første etappe:  $1,0 + 22,5 + 5,6 = 29,1$  meter fra venstre bruende til 5,6 meter forbi akse 2
2. Andre etappe: 28,0 meter fram til 5,6 meter forbi akse 3
3. Tredje etappe:  $16,9 + 1,0 = 17,9$  meter fram til høyre bruende

## Geometri og grensebetingelser

Forutsetninger:

- Brua er horisontal (ingen vertikalkurvatur) og rett (ingen horisontalkurvatur)
- Akse 1: Skivesøyle 7,5 m x 0,6 m, lagre med sidestyring og fastholding i bruas lengderetning
- Akse 2/3: Skivesøylar 5,0 m x 0,8 m, monolittisk forbindelse
- Akse 4: Skivesøyle 7,5 m x 0,6 m, lagre med sidestyring men uten fastholding i bruas lengderetning
- Fundamentering på berg i alle akser

## Materialer

Forutsetninger:

- Betongkvalitet B45
- Slakkarmering B 500 NC

## Laster

Forutsetninger for egenvekter:

- Egenvekt for endeskjørt, vanger og endetverrbærere i akse 1 og 6 neglisjeres.
- Super-egenvekt (slitelag, kantdragere og rekkverk) modelleres som sentrisk last 40 kN/m.

Forutsetninger for temperatur:

- Temperatur-virkninger:  $T_{\max} = 34 \text{ }^\circ\text{C}$ ,  $T_{\min} = -28 \text{ }^\circ\text{C}$

Forutsetninger for vindlaster:

- Brua ligger i Trondheim kommune i Sør-Trøndelag
- Retningsfaktor, sesongfaktor og nivåfaktor settes lik 1,0 ( $C_{\text{dir}}, C_{\text{season}}, C_{\text{alt}} = 1,0$ )
- Returperiode i ferdigtilstand settes lik 50 år ( $c_{\text{prob}} = 1,0$ )
- Terrengformfaktor,  $c_0(z) = 1,0$
- Overbygningens høyde over terreng,  $z = 10 \text{ m}$
- Terrengruhetskategori II
- Vindturbulens,  $k_1 = 1,0$
- Total bruplatebredde inkl kantdragere,  $b = 9,5 \text{ m}$
- Vindlast på søyler neglisjeres.

### Spennarmering

Spennarmering med 15 stk  $150 \text{ mm}^2$  tau pr kabel antas brukt. Aktuelle systemer kan være for eksempel Dywidag (DSI) eller Cona CMI BT (BBR VT). Data/forutsetninger finnes i relevante ETA'er:

- ETA-06/0022 (DSI)
- ETA-09/0286 (BBR)

ETA-ene finnes på leverandørenes nettsider. Google-søk med titlene fører som regel fram.

Kablenes/forankringenes plassering er antydnet i vedlagte figur.

I analysen kan kabler samles i grupper i CL bru.

Kabelgruppe 1 spennes opp ved akse 1 og har innstøpte passive forankringer i motsatt ende.

Kabelgruppe 2 spennes opp ved akse 4 og har innstøpte passive forankringer i motsatt ende.

Låsetapet ved aktiv forankring settes lik 6 mm.

Det forutsettes brukt kabelrør med diameter 100 mm, og minimum trykkfasthet for betongen ved oppspenning settes lik 32 MPa (sylinder) / 40 MPa (terning).

Ved utførelse i tre etapper forutsettes kabelføring tilpasset byggefasene.

### Miljø

Eksponeringsklasser: XD1 for overside, XC3 for underside.

## Oppgaver

### Oppgave 1: Prosjekteringsgrunnlag

(a) Lag en summarisk oversikt over nødvendige grunnlagsdokumenter, inkludert standarder, håndbøker, ETA'er osv. Gi en kort (to linjer) presentasjon av analyseprogrammet som benyttes.

(b) Bestem dimensjonerende materialegenskaper for både betong, slakkarmering og spennarmering. Kartlegg viktige forutsetninger vedr kryp og svinn for betongen.

- (c) Bestem viktige forutsetninger for valgt spennsystem, inkludert parametere for spennkrafttap, minimum senteravstander og kantavstander for kabelforankringene, oppspenningskraft mm.
- (d) Bestem minimumsarmering (slakkarmering) for tverrsnittet. Velg (innledende) lengdearmering med senteravstand 150 mm slik at kravet til minimumsarmering er tilfredsstillt.
- (e) Bestem nødvendig overdekning, og vis plassering av slakkarmering og spennarmering, samt kabelforankringer, i tverrsnittet.
- (f) Bestem karakteristiske verdier for alle komponenter/bidrag fra trafikklaste.
- (g) Bestem karakteristiske verdier for alle komponenter/bidrag fra temperaturlaste.
- (h) Bestem karakteristiske verdier for alle komponenter/bidrag fra vindlaste på bru uten trafikk og på bru med trafikk.
- (i) Bestem dimensjonerende lastkombinasjoner.

## Oppgave 2: Analyse

- (a) Etabler analysemodell for brua.
- (b) Vis hvordan alle forutsetninger vedrørende både geometri, grensebetingelser, materialer, laste, lastkombinasjoner og spennarmering er ivarettatt og implementert i analysen.
- (c) Verifiser viktige resultater for alle viktige lasttilfeller, delkombinasjoner og dimensjonerende lastkombinasjoner. Nevn kort hvilke forhold som *ikke* er ivarettatt eller modellert eksakt i analysen og vurder om unøyaktighetene har vesentlig betydning for resultatene.
- (d) Kontroller om SLS-krav om trykkavlastning er tilfredsstillt. Dersom kravet ikke er tilfredsstillt, øk spennarmeringsmengdene og kjør analysen på nytt.
- (e) Presenter og forklar de viktigste analyseresultatene (krefter/momente) ved diagrammer og tabeller.

## Oppgave 3: Tverrsnittskontroll

- (a) Bestem effektiv flensbredde.
- (b) Kontroller ved håndregning tverrsnittets momentkapasitet (ULS) i endefelt akse 1-2 (snitt A) og ved opplegg akse 2 (snitt B). Regn med spennarmeringen som bidrag til tverrsnittets kapasitet (indre motstand). Kontroller kapasiteten mot dimensjonerende (opptredende) momente for ULS uten forspenningens primær-effekte.
- (c) Vis at tverrsnittene kontrollert i (b) er underarmerte.
- (d) Kontroller ved håndregning tverrsnittets skjærkapasitet (ULS) ved opplegg akse 2. Finn ut om skjærarmering (bøyler) er nødvendig, og bestem eventuelt nødvendig bøylearmering og eventuelt nødvendig tillegg i lengdearmering..

(e) Kontroller ved håndregning tverrsnittets torsjonskapasitet (ULS) ved opplegg akse 2. Bestem eventuell nødvendig tverrarmring (bøyle rundt bjelkedelen av tverrsnittet) og tillegg i lengdearmring.

(f) Kontroller betongens kapasitet for skjær-trykk for kombinert skjær og torsjon.

(g) Kontroller ved håndregning trykkavlastning (snitt A) og rissvidder (snitt A og B).

#### **Oppgave 4: Diverse kontroller – frivillig**

De som ønsker kan dokumentere følgende kontroller:

- a) Skiveskjær i flenser og lastvirkninger i bruas tverretning; dimensjonering av tverrarmring i bruvingenes innspenning
- b) Kontroll av lokale krefter over lagre og ved spennarmeringsforankringer
- c) Dimensjonering av søyler, inkludert vurdering av knekk lengder/slankhet og 2. ordens tilleggs momenter

De som regner med byggefaser kan kontrollere overbygningens kapasitet i oppspenningstilstanden, dvs med spennarmeringen på trykksida.

#### **Praktiske detaljer**

Oppgavene skal besvares fullstendig – men mest mulig kortfattet. Besvarelsen skal leveres digitalt (pdf) med epost til [havard.johansen@vegvesen.no](mailto:havard.johansen@vegvesen.no). Skannede håndskrevne sider aksepteres hvis teksten er godt lesbar.

Oppgave 1 og 2 skal leveres innen **tirsdag 14. oktober kl 14.30**.  
Løsningsforslag for analysen vil deretter bli delt ut og gjennomgått.

Oppgave 3 (og eventuelt oppgave 4) skal leveres innen **tirsdag 11. november kl 15.30**.  
Arbeidet med oppgave 3 forutsettes basert på løsningsforslag for oppgave 1 og 2.



KT6003 Prosjektering av bruer 1 høsten 2014 – Prosjektoppgave

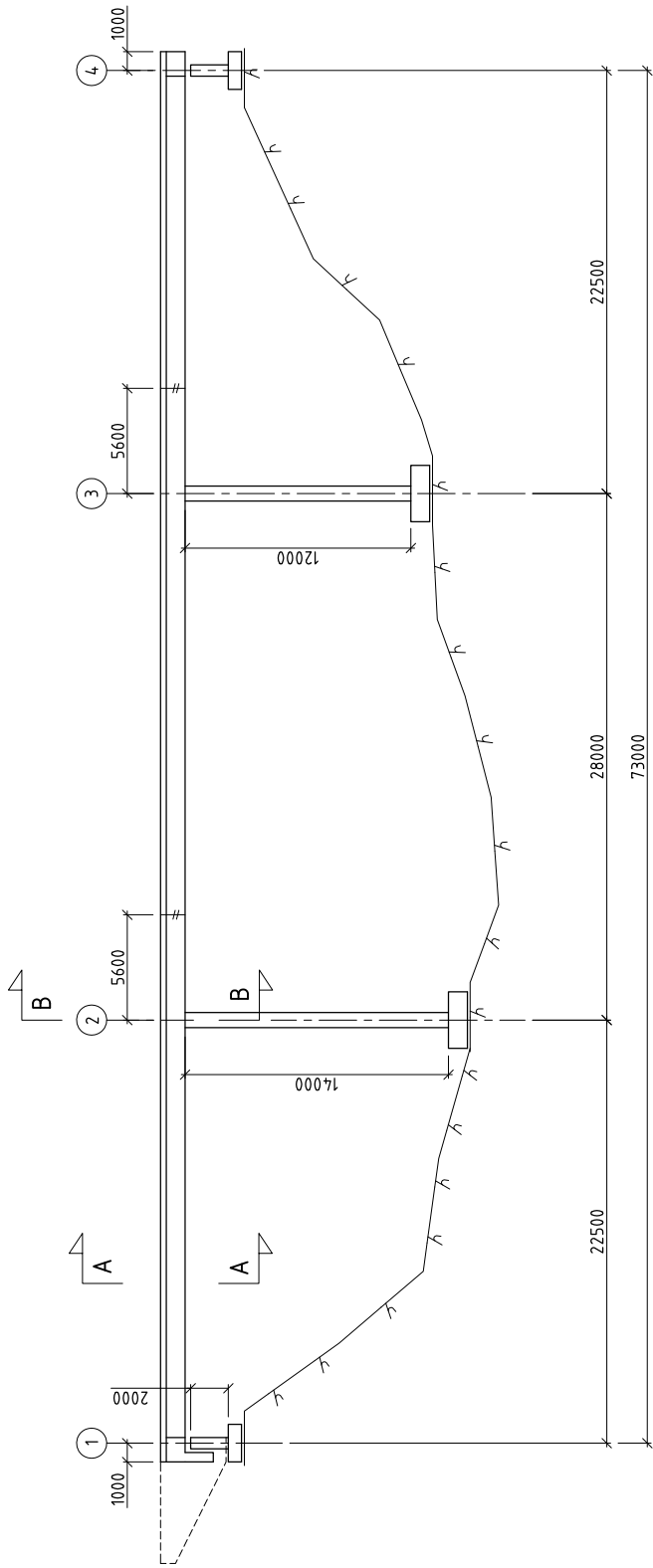

Lengdesnitt

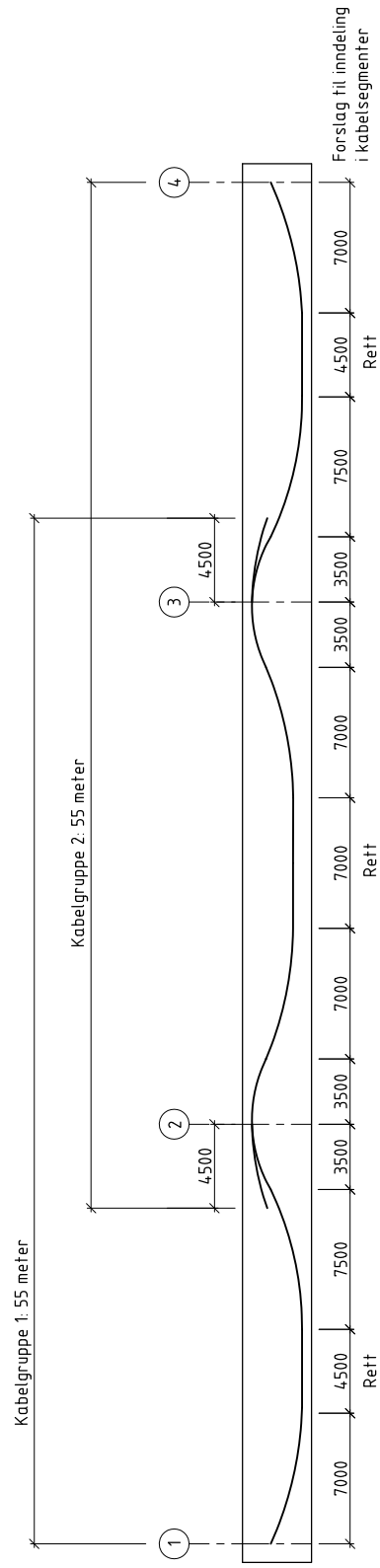

Spennarmring

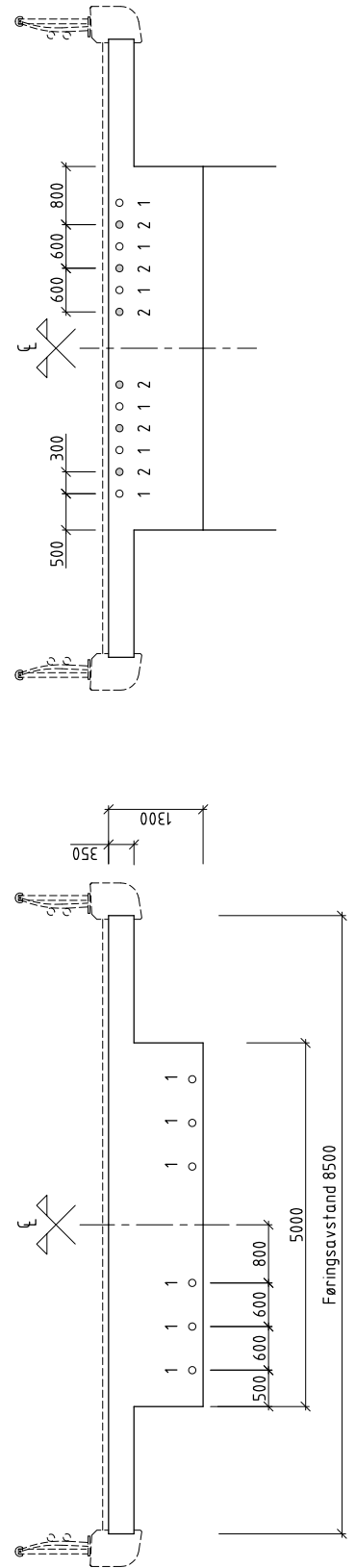

Snitt A - endefelt 1-2

Snitt B - akse 2



## Appendix B Concrete strength properties

after 7 days - prestressing stage  
according to EN 1992-1-1

$f_{ck,t} := 32 \text{ MPa}$	minimum strength for prestressing
$s := 0.25$	Type of cement (Class N)
$t := 7$	number of days
$\beta_{cc} := e^{\left( s \cdot \left( 1 - \left( \frac{28}{t} \right)^{0.5} \right) \right)} = 0.779$	(3.2)
$f_{cm,28} := 53 \text{ MPa}$	Table 3.1
$f_{cm,7} := \beta_{cc} \cdot f_{cm,28} = 41.276 \text{ MPa}$	(3.1)
$f_{ck,7} := f_{cm,7} - 8 \text{ MPa} = 33.276 \text{ MPa}$	3.1.2(5)

The concrete strength after 7 days is higher than requested strength.



## Appendix C Minimum reinforcement

according to EN 1992-1-1

### Shear

$$f_{ck} := 45 \text{ MPa} \quad f_{yk} := 500 \text{ MPa} \quad f_{ctm} := 3.8 \text{ MPa} \quad b_w := 5 \text{ m}$$

### Shear links

NA.9.2.2(5)

$$\rho_{w,min} = (0,1 \cdot \sqrt{f_{ck}}) / f_{yk} \quad \rho_{w,min} := \frac{0,1 \cdot \sqrt{\frac{f_{ck}}{\text{MPa}}}}{\frac{f_{yk}}{\text{MPa}}} = 1,342 \cdot 10^{-3}$$

Link angle between shear reinforcement and longitudinal axis is 90 degrees

$$\alpha := \frac{\pi}{2}$$

$$\text{shear} := \frac{\rho_{w,min} \cdot b_w \cdot \sin(\alpha) \cdot m}{m} = 6708 \frac{\text{mm}^2}{m} \quad (9.4)$$

$$d := 1150 \text{ mm}$$

The maximum transverse spacing of the legs

$$s_{t,max} := 0,75 \cdot d = 862,5 \text{ mm} \quad s_{t,max} = 0,75d \leq 600 \text{ mm} \quad (9.6N)$$

The design transverse spacing

$$s_{design} := 500 \text{ mm}$$

Number of links

$$n_s := \frac{b_w}{s_{design}} = 10$$

The diameter for links is 16mm

$$\phi := 16 \text{ mm}$$

$$A_{sw} := n_s \cdot \pi \cdot \left(\frac{\phi}{2}\right)^2 = 2011 \text{ mm}^2$$

The longitudinal spacing

$$s := \frac{A_{sw}}{\text{shear}} = 300 \text{ mm} \quad s_{l,max} = 0,75d (1 + \cot \alpha) \quad s_{l,max} := 0,75 \cdot d = 862,5 \text{ mm}$$

The links diameter 16 mm

The longitudinal spacing 300 mm

The transverse spacing 600 mm

## Longitudinal direction

$$A_{s,min} = 0,26(f_{ctm}/f_{yk})b_t d \geq 0,0013 b_t d$$

Assumed diameter 20 mm       $\phi := 25 \text{ mm}$        $A_s := \left(\frac{\phi}{2}\right)^2 \cdot \pi = 490.874 \text{ mm}^2$

### Bottom edge

$$d := 1300 \text{ mm} - 100 \text{ mm} - 25 \text{ mm} - \frac{25 \text{ mm}}{2} = 1162.5 \text{ mm} \quad b_t := 5 \text{ m}$$

$$A_{s,min.b1} := 0.26 \cdot \frac{f_{ctm}}{f_{yk}} \cdot b_t \cdot d = 11485.5 \text{ mm}^2$$

$$A_{s,min.b2} := 0.0013 \cdot b_t \cdot d = 7556.25 \text{ mm}^2$$

$$A_{s,min.b} := \max(A_{s,min.b1}, A_{s,min.b2}) = 11485.5 \text{ mm}^2$$

$$n_{s,min} := \frac{A_{s,min.b}}{A_s} = 23.398 \quad n_s := 25$$

### Spacing

$$s_t := \frac{b_t}{n_s} = 200 \text{ mm} \quad A_{s,min.b} := n_s \cdot A_s = 12271.846 \text{ mm}^2$$

### Top edge

$$d := 1300 \text{ mm} - 100 \text{ mm} - \frac{25 \text{ mm}}{2} = 1212.5 \text{ mm} \quad b_t := 8.5 \text{ m}$$

$$A_{s,min.t1} := 0.26 \cdot \frac{f_{ctm}}{f_{yk}} \cdot b_t \cdot d = 20365.15 \text{ mm}^2$$

$$A_{s,min.t2} := 0.0013 \cdot b_t \cdot d = 13398.125 \text{ mm}^2$$

$$A_{s,min.t} := \max(A_{s,min.t1}, A_{s,min.t2}) = 20365.15 \text{ mm}^2$$

$$n_t := \frac{A_{s,min.t}}{A_s} = 41.488 \quad n_t := 42$$

### Spacing

$$s_t := \frac{b_t}{n_t} = 202.381 \text{ mm} \quad A_{s,min.t} := n_t \cdot A_s = 20616.702 \text{ mm}^2$$

The spacing on both edges is designed 200 mm.

## Appendix D

### Concrete cover

according to EN 1992-1-1

$$c_{nom} = c_{min} + \Delta c_{dev}$$

$$c_{min} = \max(c_{min,b}; c_{min,dur} + \Delta c_{dur,\gamma} - \Delta c_{dur,st} - \Delta c_{dur,add}; 10 \text{ mm})$$

Allowance for deviation

$$\Delta c_{dev} = 10 \text{ mm for EC2}$$

$$\Delta c_{dev} = 15 \text{ mm for N400, } c_{min} < 70 \text{ mm}$$

$$\Delta c_{dev} = 20 \text{ mm for N400, } c_{min} \geq 70 \text{ mm}$$

#### TOP SURFACE XD1

For prestressing steel

Minimum cover due to environmental conditions

$$c_{min,dur} = 60 \text{ mm}$$

The minimum cover due to bond is equal to the diameter of the bars.

$$c_{min,b} = 80 \text{ mm}$$

$$c_{min} = 80 \text{ mm}$$

$$c_{nom} = 100 \text{ mm N400 (90 mm EC2)}$$

For reinforcing steel

Minimum cover due to environmental conditions

$$c_{min,dur} = 25 \text{ mm}$$

The minimum cover due to bond is equal to the diameter of the bars.

$$c_{min,b} = 60 \text{ mm}$$

$$c_{min} = 60 \text{ mm}$$

$$c_{nom} = 75 \text{ mm N400 (70 mm EC2)}$$

#### BOTTOM SURFACE XC3

For prestressing steel

Minimum cover due to environmental conditions

$$c_{min,dur} = 45 \text{ mm}$$

The minimum cover due to bond is equal to the diameter of the bars.

$$c_{min,b} = 80 \text{ mm}$$

$$c_{min} = 80 \text{ mm}$$

$$c_{nom} = 100 \text{ mm N400 (90 mm EC2)}$$

For reinforcing steel

Minimum cover due to environmental conditions

$$c_{min,dur} = 25 \text{ mm}$$

The minimum cover due to bond is equal to the diameter of the bars.

$$c_{min,b} = 50 \text{ mm}$$

$$c_{min} = 50 \text{ mm}$$

$$c_{nom} = 65 \text{ mm N400 (60 mm EC2)}$$

### **TRANSVERSE DIRECTION**

Rectangular ducts: greater of the smaller dimension or half the greater dimension

There is no requirement for more than 80 mm for either circular or rectangular ducts.

$$c_{min,b} = \left( 36,5 \text{ mm}; \frac{52,5 \text{ mm}}{2} \right) = 36,5 \text{ mm}$$

According to N400 (for prestressing steel add 10 mm to an ordinary value in Table 7.2 N400)

$$c_{min,dur} = 60 \text{ mm} + 10 \text{ mm} = 70 \text{ mm}$$

$$c_{min} = 70 \text{ mm}$$

$$c_{nom} = 90 \text{ mm N400 (80 mm EC2)}$$



## Appendix E Cable geometry

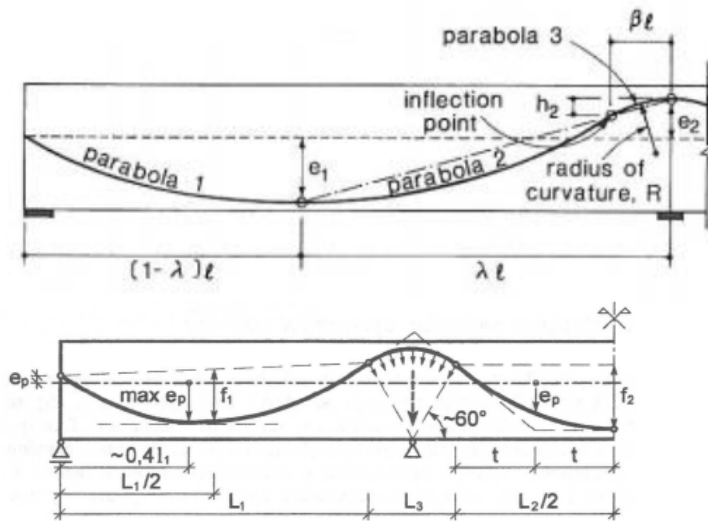

$$L_1 := 22.5 \text{ m} \quad h := 1.3 \text{ m}$$

$$o := 1.6$$

$$R_{min} := 7.2 \text{ m}$$

$$e_1 := 575 \text{ mm}$$

$$e_2 := 400 \text{ mm}$$

$$length := h \cdot \frac{o}{2} = 1.04 \text{ m}$$

$$\beta := \frac{length}{L_1} = 0.046$$

$$length_2 := \frac{R_{min} \cdot (2 \cdot e_1 + 2 \cdot e_2)}{\beta \cdot L_1} = 13.5 \text{ m}$$

$$\lambda := \frac{length_2}{L_1} = 0.6$$

$$\lambda_1 := 1 - \lambda = 0.4$$

$$\beta l := \beta \cdot L_1 = 1.04 \text{ m}$$

$$h_2 := \frac{\beta}{\lambda} \cdot (e_1 - e_2) = 0.013 \text{ m}$$



## Appendix F Wind load calculation

according to EN 1991-1-4

$$\rho := 1.25 \frac{\text{kg}}{\text{m}^3}$$

air density recommended value

$$B := 9.5 \text{ m}$$

width

Fundamental value of the basic wind velocity

$$v_{b,0} := 26 \frac{\text{m}}{\text{s}}$$

Tabell NA.4(901.1)

Basic wind velocity

NA.4.2

$$c_{dir} := 1$$

$$c_{season} := 1$$

$$c_{alt} := 1$$

$$c_{prob} := 1$$

$$v_b := c_{dir} \cdot c_{season} \cdot c_{alt} \cdot c_{prob} \cdot v_{b,0} = 26 \frac{\text{m}}{\text{s}}$$

(NA.4.1)

Mean wind

4.3

$$k_r := 0.19$$

Terrain factor for category II

$$z_0 := 0.05 \text{ m}$$

Roughness length

$$z_{min} := 2 \text{ m}$$

Minimum height

$$z := 15 \text{ m}$$

$$c_r := k_r \cdot \ln\left(\frac{z}{z_0}\right) = 1.084$$

Roughness factor

$$c_0 := 1$$

Orogaphy factor

$$v_m := c_r \cdot c_0 \cdot v_b = 28.177 \frac{\text{m}}{\text{s}}$$

Wind turbulence

4.4

$$k_l := 1$$

Turbulence factor

$$I_v := \frac{k_l}{c_0 \cdot \ln\left(\frac{z}{z_0}\right)} = 0.175$$

Peak velocity pressure

4.5

$$k_p := 3.5$$

$$q_p := 0.5 \cdot \rho \cdot v_m^2 (1 + 2 \cdot k_p \cdot I_v) = 1105 \text{ Pa} \quad (4.8)$$

Basic velocity pressure

(4.10)

$$q_b := 0.5 \cdot \rho \cdot v_b^2 = 422.5 \text{ Pa}$$

$$c_e := \frac{q_p}{q_b} = 2.616$$

Exposure factor

$$v_s := v_m$$

$$v_p := v_s \cdot \sqrt{1 + 2 \cdot k_p \cdot l_v} = 42.051 \frac{m}{s}$$

### Wind actions on the bridge - without traffic

$$d := 1.3 \text{ m}$$

$$d_{tot} := d + 0.6 \text{ m} = 1.9 \text{ m}$$

Open parapeth both side d + 0.6m

$$L := 1 \text{ m}$$

Considered just 1m length

$$A_{ref.x} := d_{tot} \cdot L = 1.9 \text{ m}^2$$

$$\frac{B}{d_{tot}} = 5$$

$$c_{fx.0} := 1.3$$

According Figure 8.3

#### Force in x-direction

8.3.2

$$C := c_e \cdot c_{fx.0} = 3.401$$

$$C := 3.6$$

Recommneded value Table 8.2

$$F_{Wx} := 0.5 \cdot \rho \cdot v_b^2 \cdot C \cdot A_{ref.x} = 2.89 \text{ kN}$$

#### Force in z-direction

8.3.3

$$A_{ref.z} := B \cdot L = 9.5 \text{ m}^2$$

$$c_{fz} := 0.9$$

NA.8.3.3

$$C := c_e \cdot c_{fz} = 2.354$$

$$F_{Wz} := 0.5 \cdot \rho \cdot v_b^2 \cdot C \cdot A_{ref.z} = 9.449 \text{ kN}$$

#### Force in y-direction

8.3.4

for plated bridges 25% of the wind forces in x-direction

$$F_{Wy} := 0.25 \cdot F_{Wx} = 0.722 \text{ kN}$$

## Wind actions on the bridge - with traffic

$$d := 1.3 \text{ m}$$

$$d_{tot.t} := d + 2 \text{ m} = 3.3 \text{ m} \quad 8.3.1 (5) a)$$

$$L := 1 \text{ m} \quad \text{Considered just 1m length}$$

$$A_{ref.xt} := d_{tot.t} \cdot L$$

$$\frac{B}{d_{tot.t}} = 2.879$$

$$c_{fx.ot} := 1.6 \quad \text{NA.8.1(4)}$$

$$v_{kast} := 35 \frac{\text{m}}{\text{s}}$$

$$q_{pt} := 0.5 \cdot \rho \cdot v_{kast}^2 = 766 \text{ Pa}$$

$$c_{et} := \frac{q_{pt}}{q_b} = 1.812 \quad \text{According Figure 8.3}$$

### Force in x-direction 8.3.2

$$C_t := c_{et} \cdot c_{fx.ot} = 2.899$$

Recommmended value Table 8.2

$$F_{Wxt} := 0.5 \cdot \rho \cdot v_b^2 \cdot C_t \cdot A_{ref.xt} = 4.043 \text{ kN}$$

### Force in z-direction 8.3.3

$$A_{ref.zt} := B \cdot L = 9.5 \text{ m}^2$$

$$c_{f.zt} := 0.9 \quad \text{NA.8.3.3}$$

$$C := c_{et} \cdot c_{f.zt} = 1.631$$

$$F_{Wz} := 0.5 \cdot \rho \cdot v_b^2 \cdot C \cdot A_{ref.z} = 6.546 \text{ kN}$$

### Force in y-direction 8.3.4

for plated bridges 25% of the wind forces in x-direction

$$F_{Wyt} := 0.25 \cdot F_{Wxt} = 1.011 \text{ kN}$$

(5) If not otherwise specified the eccentricity of the force in the x-direction may be set to  $e = b/4$ .



## Appendix G Creep and shrinkage strain

according to EN 1992-1-1 and N400

The relative humidity of the ambient environment 70%

$$RH := 70 \quad f_{cm} := 53 \text{ MPa} \quad t_0 := 7$$

$$A_c := 7.725 \cdot m^2$$

cross-sectional area

$$u := 2 \cdot (8.5 \text{ m} + 1.3 \text{ m}) = 19.6 \text{ m}$$

perimetr of the member in contact with the atmosphere

$$h_0 := \frac{2 A_c}{u} = 788.265 \text{ mm} \quad (\text{B.6}) \quad \text{notional size of the member}$$

$$\alpha_1 := \left( \frac{35 \text{ MPa}}{f_{cm}} \right)^{0.7} = 0.748 \quad (\text{B.8c}) \quad \text{coefficients to consider the influence of the concrete strength}$$

$$\alpha_2 := \left( \frac{35 \text{ MPa}}{f_{cm}} \right)^{0.2} = 0.92$$

$$\alpha_3 := \left( \frac{35 \text{ MPa}}{f_{cm}} \right)^{0.5} = 0.813$$

$$\beta_H := \min \left( 1.5 \cdot \left( 1 + (0.012 \cdot RH)^{18} \right) \cdot \frac{h_0}{\text{mm}} + 250 \cdot \alpha_3, 1500 \cdot \alpha_3 \right)$$

$$\beta_H = 1.219 \cdot 10^3 \quad (\text{B.8b}) \quad \text{coefficients to consider the influence of the concrete strength for } f_{cm} > 35 \text{ MPa}$$

$$\varphi_{RH} := \left( 1 + \frac{1 - \frac{RH}{100}}{0.1 \cdot \sqrt[3]{\frac{h_0}{\text{mm}}}} \cdot \alpha_1 \right) \cdot \alpha_2 \quad (\text{B.3b}) \quad \text{factor to allow for the effect of relative humidity on the notional creep coefficient for } f_{cm} > 35 \text{ MPa}$$

$$\varphi_{RH} = 1.144$$

$$\beta \cdot f_{cm} := \frac{16.8}{\sqrt{\frac{f_{cm}}{\text{MPa}}}} = 2.308 \quad (\text{B.4}) \quad \text{factor to allow for the effect of concrete strength on the notional creep coefficient}$$

$$\beta \cdot t_0 := \frac{1}{(0.1 + t_0^{0.2})} = 0.635 \quad (\text{B.5}) \quad \text{factor to allow for the effect of concrete age at loading on the notional creep coefficient}$$

$$\varphi_0 := \varphi_{RH} \cdot \beta \cdot f_{cm} \cdot \beta \cdot t_0 = 1.675 \quad (\text{B.2}) \quad \text{the notional creep coefficient}$$

## Creep

$$\beta_c(t, t_0) := \left( \frac{t - t_0}{\beta_H + t + t_0} \right)^{0.3} \quad (\text{B.7})$$

a coefficient to describe the development of creep with time after loading

$$\varphi(t, t_0) := \varphi_0 \cdot \beta_c(t, t_0) \quad (\text{B.1})$$

the creep coefficient

### Creep at 28 days ( 1st building phase)

$$t := 28 \quad t_0 := 7$$

$$\beta_{c.28.7} := \left( \frac{t - t_0}{\beta_H + t + t_0} \right)^{0.3} = 0.293$$

$$\varphi_{28.7} := \varphi_0 \cdot \beta_{c.28.7} = 0.491$$

### Creep at 56 days ( 2nd building phase)

$$t := 56 \quad t_0 := 7$$

$$\beta_{c.56.7} := \left( \frac{t - t_0}{\beta_H + t + t_0} \right)^{0.3} = 0.376$$

$$\varphi_{56.7} := \varphi_0 \cdot \beta_{c.56.7} = 0.629$$

### Creep at 84 days ( final stage)

$$t := 84 \quad t_0 := 7$$

$$\beta_{c.84.7} := \left( \frac{t - t_0}{\beta_H + t + t_0} \right)^{0.3} = 0.427$$

$$\varphi_{84.7} := \varphi_0 \cdot \beta_{c.84.7} = 0.716$$

### Creep at 112 days ( final stage)

$$t := 112 \quad t_0 := 7$$

$$\beta_{c.112.7} := \left( \frac{t - t_0}{\beta_H + t + t_0} \right)^{0.3} = 0.466$$

$$\varphi_{112.7} := \varphi_0 \cdot \beta_{c.112.7} = 0.781$$



**Creep at 100 years (36500 days)**

$t := 36500 \quad t_0 := 7$

$$\beta_{c.36500.7} := \left( \frac{t - t_0}{\beta_H + t + t_0} \right)^{0.3} = 0.99$$

$\varphi_{36500.7} := \varphi_0 \cdot \beta_{c.36500.7} = 1.659$

$t := 0, 1..112$

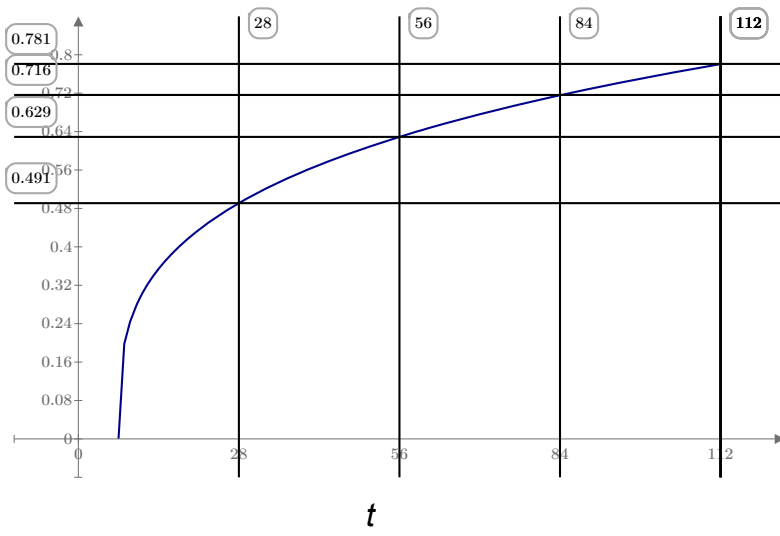

$$\frac{\varphi_0 \cdot \left( \frac{t - 7}{\beta_H + t + 7} \right)^{0.3}}{\quad}$$

$t := 0, 1..3650$

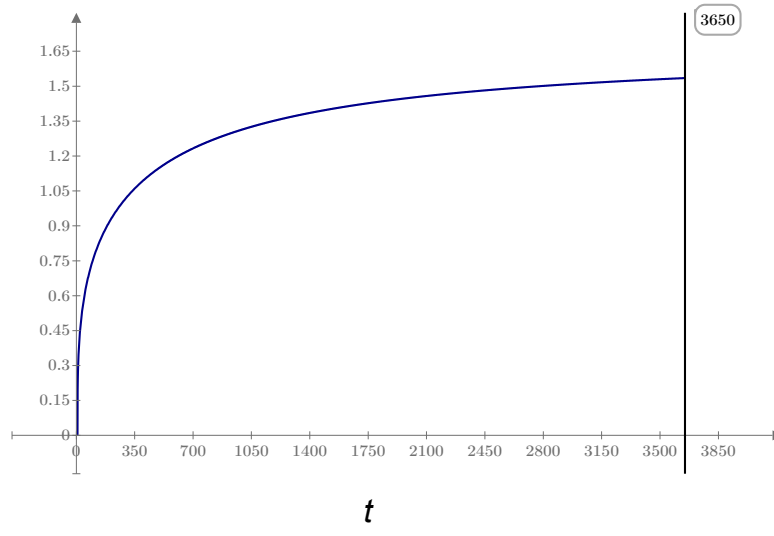

$$\frac{\varphi_0 \cdot \left( \frac{t - 7}{\beta_H + t + 7} \right)^{0.3}}{\quad}$$

## Shrinkage

$$f_{ck} := 45 \text{ MPa}$$

$$RH_0 := 100$$

Basic equations for determining the drying shrinkage strain B.2

$$\alpha_{ds1} := 4 \quad \alpha_{ds2} := 0.12 \quad \text{for cement class N}$$

coefficients which depend on the type of cement

$$f_{cm0} := 10 \text{ MPa}$$

$$\beta_{RH} := 1.55 \cdot \left( 1 - \left( \frac{RH}{RH_0} \right)^3 \right) = 1.018 \quad (\text{B.12})$$

The drying shrinkage

$$\varepsilon_{cd,0} := 0.85 \cdot \left( (220 + 110 \cdot \alpha_{ds1}) \cdot e^{\left( -\alpha_{ds2} \cdot \frac{f_{cm}}{f_{cm0}} \right)} \right) \cdot 10^{-6} \cdot \beta_{RH} \quad (\text{B.11}) \quad \text{the basic drying shrinkage}$$

$$\varepsilon_{cd,0} = 3.024 \cdot 10^{-4}$$

$$k_h := 0.7 \quad h_0 \geq 500$$

Table 3.3 coefficient depending on the notional size of the member

$$\beta_{ds}(t, t_s) \quad (3.10)$$

$$t := 36500$$

$$t_s := 7$$

$$\beta_{ds} := \frac{(t - t_s)}{(t - t_s) + 0.04 \cdot \sqrt{\left( \frac{h_0}{\text{mm}} \right)^3}} = 0.976$$

$$\varepsilon_{cd} := \beta_{ds} \cdot k_h \cdot \varepsilon_{cd,0} = 2.067 \cdot 10^{-4} \quad (3.9) \quad \text{the drying shrinkage strain}$$

The autogenous shrinkage

$$\beta_{as} := 1 - e^{(-0.2 \cdot t^{0.5})} = 1 \quad (3.13)$$

$$\varepsilon_{ca\infty} := 2.5 \cdot \left( \frac{f_{ck}}{\text{MPa}} - 10 \right) \cdot 10^{-6} = 8.75 \cdot 10^{-5} \quad (3.12)$$

$$\varepsilon_{ca} := \beta_{as} \cdot \varepsilon_{ca\infty} = 8.75 \cdot 10^{-5}$$

$$\varepsilon_{cs} := \varepsilon_{cd} + \varepsilon_{ca} = 2.942 \cdot 10^{-4} \quad (3.8) \quad \text{the total shrinkage strain}$$

## Appendix H Creep loss

$$f_{ck} := 45 \text{ MPa} \quad f_{ctm} := 3.8 \text{ MPa}$$

$$\alpha_{cc} := 0.85$$

$$E_c := 36000 \text{ MPa} \quad \varphi_{100} := 1.6886$$

$$E_{cm} := \frac{E_c}{1 + \varphi_{100}} = 13390 \text{ MPa}$$

$$\gamma_c := 1.5$$

$$\gamma_s := 1.15$$

$$\gamma_p := 1.15$$

$$f_{cd} := \alpha_{cc} \cdot \frac{f_{ck}}{\gamma_c} = 25.5 \text{ MPa}$$

$$f_{ctk.0.05} := 2.7 \text{ MPa}$$

$$f_{ctd} := \alpha_{cc} \cdot \frac{f_{ctk.0.05}}{\gamma_c} = 1.53 \text{ MPa}$$

$$f_{p.0.1k} := 1600 \text{ MPa}$$

$$f_{pk} := 1860 \text{ MPa}$$

$$f_{pd} := \frac{f_{pk}}{\gamma_p} = 1617 \text{ MPa}$$

$$E_p := 195000 \text{ MPa}$$

$$\sigma_{p0} := 0.85 \cdot f_{p.0.1k} = 1360 \text{ MPa}$$

$$\sigma_{p.max} := 0.89 \cdot f_{p.0.1k} = 1424 \text{ MPa}$$

$$\eta := \frac{E_p}{E_{cm}} = 14.563$$

$$h := 1.3 \text{ m}$$

$$h_{flange} := 0.35 \text{ m}$$

$$b_{web} := 5 \text{ m}$$

Span

$$b_{eff} := 8.5 \text{ m}$$

Support

$$b_{eff.support} := 7.215 \text{ m}$$

$$COG_{z.down} := 725 \text{ mm}$$

$$COG_{s.z.down} := 702 \text{ mm}$$

$$COG_{z.up} := 575 \text{ mm}$$

$$COG_{s.z.up} := 598 \text{ mm}$$

## Middle span

$$M_{sw} := 9757 \text{ kN}\cdot\text{m} \quad N := -\sigma_{p,max} \cdot 8 \cdot 2250 \cdot \text{mm}^2 = -25632 \text{ kN}$$

$$e_{p,span} := 575 \text{ mm} \quad A := 7.725 \text{ m}^2$$

$$I := 1.16 \text{ m}^4$$

$$M_{pr} := e_{p,span} \cdot N = -14738.4 \text{ kN}\cdot\text{m}$$

$$M := M_{pr} + M_{sw} = -4981.4 \text{ kN}\cdot\text{m}$$

Upper edge of cross section

$$\sigma_c := \frac{N}{A} + \frac{M \cdot (-COG_{z,up})}{I} = -0.849 \text{ MPa}$$

Lower edge of cross section

$$\sigma_c := \frac{N}{A} - \frac{M \cdot (-COG_{z,down})}{I} = -6.431 \text{ MPa}$$

In prestressing

Strain

$$\sigma_{c,1} := \frac{N}{A} - \frac{M \cdot (-e_{p,span})}{I} = -5.787 \text{ MPa} \quad \epsilon_{c,c1} := \frac{N}{A \cdot E_c} - \frac{M \cdot (-e_{p,span})}{I \cdot E_{cm}} = -2.766 \cdot 10^{-4}$$

## Over support

$$M_{sw} := 10198 \text{ kN}\cdot\text{m} \quad N := -\sigma_{p,max} \cdot 10 \cdot 2250 \cdot \text{mm}^2 = -32040 \text{ kN}$$

$$e_{p,span} := 400 \text{ mm}$$

$$M_{pr} := (e_{p,span}) \cdot N = -12816 \text{ kN}\cdot\text{m}$$

$$M := M_{pr} + M_{sw} = -2618 \text{ kN}\cdot\text{m}$$

Upper edge of cross section

$$\sigma_c := \frac{N}{A} - \frac{M \cdot (-COG_{s,z,up})}{I} = -5.497 \text{ MPa}$$

Lower edge of cross section

$$\sigma_c := \frac{N}{A} + \frac{M \cdot (-COG_{s,z,down})}{I} = -2.563 \text{ MPa}$$

In prestressing

Strain

$$\sigma_{c,2} := \frac{N}{A} - \frac{M \cdot (-e_{p,span})}{I} = -5.05 \text{ MPa} \quad \epsilon_{c,c2} := \frac{N}{A \cdot E_c} - \frac{M \cdot (-e_{p,span})}{I \cdot E_{cm}} = -1.826 \cdot 10^{-4}$$

## Creep for use in NovaFrame

Average

$$\epsilon_{cc} := \frac{\epsilon_{c,c1} + \epsilon_{c,c2}}{2} \cdot 1000 = 0.230$$

## Appendix I Verification of self-weight

$$A_{deck} := 7.725 \text{ m}^2$$

$$A_{column} := 0.8 \text{ m} \cdot 5 \text{ m} = 4 \text{ m}^2$$

$$Y_{concrete} := 25 \frac{\text{kN}}{\text{m}^3}$$

$$g_{SW} := A_{deck} \cdot Y_{concrete} = 193.125 \frac{\text{kN}}{\text{m}}$$

$$g_{SWc} := A_{column} \cdot Y_{concrete} = 100 \frac{\text{kN}}{\text{m}}$$

$$E := 36000 \text{ MPa}$$

### Moment of inertia

$$I_{deck} := 1.1605 \text{ m}^4$$

$$I_{column} := \frac{1.5 \text{ m} \cdot (0.8 \text{ m})^3}{12}$$

$$I_d := I_{deck} = 1 \text{ m}^4$$

$$I_c := I_{column} = 0.2 \text{ m}^4$$

$$L_{AB} := 22.5 \text{ m} \quad L_{CD} := L_{AB} = 22.5 \text{ m} \quad L_{BC} := 28 \text{ m} \quad L_{BE} := 15 \text{ m} \quad L_{CF} := 13 \text{ m}$$

$$EI_1 := I_d \cdot E = 41778000 \text{ kN} \cdot \text{m}^2$$

$$EI_2 := I_c \cdot E = 7680000 \text{ kN} \cdot \text{m}^2$$

$$R_0 := \begin{bmatrix} \frac{g_{SW} \cdot L_{AB}^2}{8} - \frac{g_{SW} \cdot L_{BC}^2}{12} \\ \frac{g_{SW} \cdot L_{BC}^2}{12} - \frac{g_{SW} \cdot L_{CD}^2}{8} \end{bmatrix} = \begin{bmatrix} -396 \\ 396 \end{bmatrix} \text{ kN} \cdot \text{m}$$

$$R_k := 0$$

$$R_{load} := R_k - R_0 = \begin{bmatrix} 396 \\ -396 \end{bmatrix} \text{ kN} \cdot \text{m}$$

### Stiffness

$$K := \begin{bmatrix} \frac{3 \cdot EI_1}{L_{AB}} + \frac{4 \cdot EI_1}{L_{BC}} + \frac{4 \cdot EI_2}{L_{BE}} & \frac{2 \cdot EI_1}{L_{BC}} \\ \frac{2 \cdot EI_1}{L_{BC}} & \frac{3 \cdot EI_1}{L_{AB}} + \frac{4 \cdot EI_1}{L_{BC}} + \frac{4 \cdot EI_2}{L_{CF}} \end{bmatrix} = \begin{bmatrix} 13586686 & 2984143 \\ 2984143 & 13901763 \end{bmatrix} \text{ kN} \cdot \text{m}$$

$$r := K^{-1} \cdot R_{load} = \begin{bmatrix} 3.72 \cdot 10^{-5} \\ -3.65 \cdot 10^{-5} \end{bmatrix}$$

$$r_1 := r \cdot \begin{bmatrix} 1 \\ 0 \end{bmatrix} = 3.718336 \cdot 10^{-5}$$

$$r_2 := r \cdot \begin{bmatrix} 0 \\ 1 \end{bmatrix} = -3.6489549 \cdot 10^{-5}$$

$$M_{BA} := \frac{g_{SW}}{8} \cdot L_{AB}^2 + \frac{3 \cdot EI_1}{L_{AB}} \cdot r_1 = 12428 \text{ kN}\cdot\text{m}$$

$$M_{BC} := \frac{g_{SW}}{12} \cdot L_{BC}^2 - \frac{4 \cdot EI_1}{L_{BC}} \cdot r_1 - \frac{2 \cdot EI_1}{L_{BC}} \cdot r_2 = 12504 \text{ kN}\cdot\text{m}$$

$$M_{CB} := \frac{g_{SW}}{12} \cdot L_{BC}^2 + \frac{2 \cdot EI_1}{L_{BC}} \cdot r_1 + \frac{4 \cdot EI_1}{L_{BC}} \cdot r_2 = 12511 \text{ kN}\cdot\text{m}$$

$$M_{CD} := \frac{g_{SW}}{8} \cdot L_{CD}^2 - \frac{3 \cdot EI_1}{L_{CD}} \cdot r_2 = 12424 \text{ kN}\cdot\text{m}$$

$$M_{BE} := \frac{4 \cdot EI_2}{L_{BE}} \cdot r_1 = 76 \text{ kN}\cdot\text{m}$$

$$M_{CF} := \frac{4 \cdot EI_2}{L_{CF}} \cdot r_2 = -86 \text{ kN}\cdot\text{m}$$

$$V_A := \frac{M_{BA} - g_{SW} \cdot \frac{L_{AB}^2}{2}}{L_{AB}} = 1620 \text{ kN}$$

$$V_D := \frac{M_{CD} - g_{SW} \cdot \frac{L_{CD}^2}{2}}{L_{CD}} = 1620 \text{ kN}$$

$$V_{BA} := V_A - L_{AB} \cdot g_{SW} = -2725 \text{ kN}$$

$$V_{CD} := V_D - L_{CD} \cdot g_{SW} = -2725 \text{ kN}$$

$$V_E := \frac{M_{BE}}{L_{BE}} = 5 \text{ kN}$$

$$V_F := \frac{M_{CF}}{L_{CF}} = -7 \text{ kN}$$

$$A_z := V_A = 1620 \text{ kN}$$

$$D_z := V_D = 1620 \text{ kN}$$

$$G_{total} := g_{SW} \cdot (L_{AB} + L_{BC} + L_{CD}) = 14098 \text{ kN}$$

$$Q := G_{total} - A_z - D_z = 10857 \text{ kN}$$

$$L_{tot} := L_{AB} + L_{BC} + L_{CD} = 73 \text{ m}$$

$$F_{z.top} := \frac{g_{SW} \cdot \frac{L_{tot}^2}{2} - V_E \cdot L_{BE} - V_F \cdot L_{CF} - V_D \cdot L_{tot} - L_{AB} \cdot Q}{L_{BC}} = 5429 \text{ kN}$$

$$E_{z.top} := G_{total} - A_z - D_z - F_{z.top} = 5429 \text{ kN}$$

$$V_{BC} := V_{BA} + E_{z.top} = 2704 \text{ kN}$$

$$V_{CB} := V_{BC} - g_{SW} \cdot L_{BC} = -2704 \text{ kN}$$

$$E_{col} := g_{SWc} \cdot L_{BE} = 1500 \text{ kN}$$

$$F_{col} := g_{SWc} \cdot L_{CF} = 1300 \text{ kN}$$

$$E_z := E_{z.top} + E_{col} = 6929 \text{ kN}$$

$$F_z := F_{z.top} + F_{col} = 6729 \text{ kN}$$

$$x_1 := \frac{V_A}{g_{SW}} = 8.39 \text{ m}$$

$$x_2 := \frac{V_{BC}}{g_{SW}} = 14 \text{ m}$$

$$x_3 := \frac{V_D}{g_{SW}} = 8.39 \text{ m}$$

$$M_{max.span1} := V_A \cdot x_1 - \frac{g_{SW} \cdot x_1^2}{2} = 6797 \text{ kN} \cdot \text{m}$$

$$M_{max.span2} := -M_{BC} + V_{BC} \cdot x_2 - \frac{g_{SW} \cdot x_2^2}{2} = 6419 \text{ kN} \cdot \text{m}$$

$$M_{max.span3} := V_D \cdot x_3 - \frac{g_{SW} \cdot x_3^2}{2} = 6798 \text{ kN} \cdot \text{m}$$

$$M_{max.supportB} := M_{BC} = 12504 \text{ kN} \cdot \text{m}$$

$$M_{max.supportC} := M_{CB} = 12511 \text{ kN} \cdot \text{m}$$

Total weight

$$G_{total} := L_{tot} \cdot g_{SW} + (L_{BE} + L_{CF}) \cdot g_{SWc} = 16898 \text{ kN}$$

Sum reactions

$$G_{reactions} := A_z + E_z + F_z + D_z = 16898 \text{ kN}$$

## Summary

Shear

$$V_{AB} := V_A = 1620 \text{ kN}$$

$$V_{BA} = -2725 \text{ kN}$$

$$V_{BC} = 2704 \text{ kN}$$

$$V_{CB} = -2704 \text{ kN}$$

$$V_{CD} = -2725 \text{ kN}$$

$$V_{DC} := V_D = 1620 \text{ kN}$$

Reactions

$$A_z = 1620 \text{ kN}$$

$$E_z = 6929 \text{ kN}$$

$$F_z = 6729 \text{ kN}$$

$$D_z = 1620 \text{ kN}$$

Moments

$$M_{max.span1} := V_A \cdot x_1 - \frac{g_{sw} \cdot x_1^2}{2} = 6797 \text{ kN} \cdot m$$

$$M_{max.span2} := -M_{BC} + V_{BC} \cdot x_2 - \frac{g_{sw} \cdot x_2^2}{2} = 6419 \text{ kN} \cdot m$$

$$M_{max.span3} := V_D \cdot x_3 - \frac{g_{sw} \cdot x_3^2}{2} = 6798 \text{ kN} \cdot m$$

$$M_{max.supportB} := M_{BC} = 12504 \text{ kN} \cdot m$$

$$M_{max.supportC} := M_{CB} = 12511 \text{ kN} \cdot m$$



## Appendix J Verification of wind load

$$g_{SW} := 9.5 \frac{\text{kN}}{\text{m}}$$

$$g_{SWc} := 0$$

$$E := 36000 \text{ MPa}$$

### Moment of inertia

$$I_{deck} := 1.1605 \text{ m}^4$$

$$I_{column} := \frac{1.5 \text{ m} \cdot (0.8 \text{ m})^3}{12}$$

$$I_d := I_{deck} = 1 \text{ m}^4$$

$$I_c := I_{column} = 0.2 \text{ m}^4$$

$$L_{AB} := 22.5 \text{ m} \quad L_{CD} := L_{AB} = 22.5 \text{ m} \quad L_{BC} := 28 \text{ m} \quad L_{BE} := 15 \text{ m} \quad L_{CF} := 13 \text{ m}$$

$$EI_1 := I_d \cdot E = 41778000 \text{ kN} \cdot \text{m}^2$$

$$EI_2 := I_c \cdot E = 7680000 \text{ kN} \cdot \text{m}^2$$

$$R_0 := \begin{bmatrix} \frac{g_{SW} \cdot L_{AB}^2}{8} - \frac{g_{SW} \cdot L_{BC}^2}{12} \\ \frac{g_{SW} \cdot L_{BC}^2}{12} - \frac{g_{SW} \cdot L_{CD}^2}{8} \end{bmatrix} = \begin{bmatrix} -19 \\ 19 \end{bmatrix} \text{ kN} \cdot \text{m}$$

$$R_k := 0$$

$$R_{load} := R_k - R_0 = \begin{bmatrix} 19 \\ -19 \end{bmatrix} \text{ kN} \cdot \text{m}$$

### Stiffness

$$K := \begin{bmatrix} \frac{3 \cdot EI_1}{L_{AB}} + \frac{4 \cdot EI_1}{L_{BC}} + \frac{4 \cdot EI_2}{L_{BE}} & \frac{2 \cdot EI_1}{L_{BC}} \\ \frac{2 \cdot EI_1}{L_{BC}} & \frac{3 \cdot EI_1}{L_{AB}} + \frac{4 \cdot EI_1}{L_{BC}} + \frac{4 \cdot EI_2}{L_{CF}} \end{bmatrix} = \begin{bmatrix} 13586686 & 2984143 \\ 2984143 & 13901763 \end{bmatrix} \text{ kN} \cdot \text{m}$$

$$r := K^{-1} \cdot R_{load} = \begin{bmatrix} 1.83 \cdot 10^{-6} \\ -1.79 \cdot 10^{-6} \end{bmatrix}$$

$$r_1 := r \cdot \begin{bmatrix} 1 \\ 0 \end{bmatrix} = 1.8290844 \cdot 10^{-6}$$

$$r_2 := r \cdot \begin{bmatrix} 0 \\ 1 \end{bmatrix} = -1.7949552 \cdot 10^{-6}$$

$$M_{BA} := \frac{g_{SW}}{8} \cdot L_{AB}^2 + \frac{3 \cdot EI_1}{L_{AB}} \cdot r_1 = 611 \text{ kN}\cdot\text{m}$$

$$M_{BC} := \frac{g_{SW}}{12} \cdot L_{BC}^2 - \frac{4 \cdot EI_1}{L_{BC}} \cdot r_1 - \frac{2 \cdot EI_1}{L_{BC}} \cdot r_2 = 615 \text{ kN}\cdot\text{m}$$

$$M_{CB} := \frac{g_{SW}}{12} \cdot L_{BC}^2 + \frac{2 \cdot EI_1}{L_{BC}} \cdot r_1 + \frac{4 \cdot EI_1}{L_{BC}} \cdot r_2 = 615 \text{ kN}\cdot\text{m}$$

$$M_{CD} := \frac{g_{SW}}{8} \cdot L_{CD}^2 - \frac{3 \cdot EI_1}{L_{CD}} \cdot r_2 = 611 \text{ kN}\cdot\text{m}$$

$$M_{BE} := \frac{4 \cdot EI_2}{L_{BE}} \cdot r_1 = 4 \text{ kN}\cdot\text{m}$$

$$M_{CF} := \frac{4 \cdot EI_2}{L_{CF}} \cdot r_2 = -4 \text{ kN}\cdot\text{m}$$

$$V_A := -\frac{M_{BA} - g_{SW} \cdot \frac{L_{AB}^2}{2}}{L_{AB}} = 80 \text{ kN}$$

$$V_D := -\frac{M_{CD} - g_{SW} \cdot \frac{L_{CD}^2}{2}}{L_{CD}} = 80 \text{ kN}$$

$$V_{BA} := V_A - L_{AB} \cdot g_{SW} = -134 \text{ kN}$$

$$V_{CD} := V_D - L_{CD} \cdot g_{SW} = -134 \text{ kN}$$

$$V_E := \frac{M_{BE}}{L_{BE}} = 0 \text{ kN}$$

$$V_F := \frac{M_{CF}}{L_{CF}} = 0 \text{ kN}$$

$$A_z := V_A = 80 \text{ kN}$$

$$D_z := V_D = 80 \text{ kN}$$

$$G_{total} := g_{SW} \cdot (L_{AB} + L_{BC} + L_{CD}) = 694 \text{ kN}$$

$$Q := G_{total} - A_z - D_z = 534 \text{ kN}$$

$$L_{tot} := L_{AB} + L_{BC} + L_{CD} = 73 \text{ m}$$

$$F_{z.top} := \frac{g_{SW} \cdot \frac{L_{tot}^2}{2} - V_E \cdot L_{BE} - V_F \cdot L_{CF} - V_D \cdot L_{tot} - L_{AB} \cdot Q}{L_{BC}} = 267 \text{ kN}$$

$$E_{z.top} := G_{total} - A_z - D_z - F_{z.top} = 267 \text{ kN}$$

$$V_{BC} := V_{BA} + E_{z.top} = 133 \text{ kN}$$

$$V_{CB} := V_{BC} - g_{SW} \cdot L_{BC} = -133 \text{ kN}$$

$$E_{col} := g_{SWc} \cdot L_{BE} = 0 \frac{\text{s}^2}{\text{kg}} \cdot \text{kN}$$

$$F_{col} := g_{SWc} \cdot L_{CF} = 0 \frac{\text{s}^2}{\text{kg}} \cdot \text{kN}$$

$$E_z := E_{z.top} = 267 \text{ kN}$$

$$F_z := F_{z.top} = 267 \text{ kN}$$

$$x_1 := \frac{V_A}{g_{SW}} = 8.39 \text{ m}$$

$$x_2 := \frac{V_{BC}}{g_{SW}} = 14 \text{ m}$$

$$x_3 := \frac{V_D}{g_{SW}} = 8.39 \text{ m}$$

$$M_{max.span1} := V_A \cdot x_1 - \frac{g_{SW} \cdot x_1^2}{2} = 334 \text{ kN} \cdot \text{m}$$

$$M_{max.span2} := -M_{BC} + V_{BC} \cdot x_2 - \frac{g_{SW} \cdot x_2^2}{2} = 316 \text{ kN} \cdot \text{m}$$

$$M_{max.span3} := V_D \cdot x_3 - \frac{g_{SW} \cdot x_3^2}{2} = 334 \text{ kN} \cdot \text{m}$$

$$M_{max.supportB} := M_{BC} = 615 \text{ kN} \cdot \text{m}$$

$$M_{max.supportC} := M_{CB} = 615 \text{ kN} \cdot \text{m}$$

Total weight

$$G_{total} := L_{tot} \cdot g_{SW} = 694 \text{ kN}$$

Sum reactions

$$G_{reactions} := A_z + E_z + F_z + D_z = 694 \text{ kN}$$

## Summary

### Shear

$$V_{AB} := V_A = 80 \text{ kN}$$

$$V_{BA} = -134 \text{ kN}$$

$$V_{BC} = 133 \text{ kN}$$

$$V_{CB} = -133 \text{ kN}$$

$$V_{CD} = -134 \text{ kN}$$

$$V_{DC} := V_D = 80 \text{ kN}$$

### Reactions

$$A_z = 80 \text{ kN}$$

$$E_z = 267 \text{ kN}$$

$$F_z = 267 \text{ kN}$$

$$D_z = 80 \text{ kN}$$

### Moments

$$M_{max.span1} := V_A \cdot x_1 - \frac{g_{SW} \cdot x_1^2}{2} = 334 \text{ kN} \cdot m$$

$$M_{max.span2} := -M_{BC} + V_{BC} \cdot x_2 - \frac{g_{SW} \cdot x_2^2}{2} = 316 \text{ kN} \cdot m$$

$$M_{max.span3} := V_D \cdot x_3 - \frac{g_{SW} \cdot x_3^2}{2} = 334 \text{ kN} \cdot m$$

$$M_{max.supportB} := M_{BC} = 615 \text{ kN} \cdot m$$

$$M_{max.supportC} := M_{CB} = 615 \text{ kN} \cdot m$$

## Appendix K Verification of temperature load

$$\Delta T_{m.heat} := 15$$

$$E := 36000 \text{ MPa} \quad h := 1.3 \text{ m}$$

$$\alpha_T := 10^{-5}$$

$$I_b := 1.1605 \text{ m}^4 \quad I_c := \frac{1.5 \text{ m} \cdot (0.8 \text{ m})^3}{12} = 0 \text{ m}^4$$

$$L_{AB} := 22.5 \text{ m} \quad L_{CD} := L_{AB} = 22.5 \text{ m} \quad L_{BC} := 28 \text{ m} \quad L_{BE} := 15 \text{ m} \quad L_{CF} := 13 \text{ m}$$

$$K := \frac{\Delta T_{m.heat} \cdot \alpha_T}{h} = (1.154 \cdot 10^{-4}) \frac{1}{\text{m}}$$

$$k_{11} := \frac{4 \cdot E \cdot I_b}{L_{AB}} \quad k_{12} := \frac{2 \cdot E \cdot I_b}{L_{AB}} \quad k_{13} := 0 \quad k_{14} := 0$$

$$k_{21} := \frac{2 \cdot E \cdot I_b}{L_{AB}} \quad k_{22} := \frac{4 \cdot E \cdot I_b}{L_{AB}} + \frac{4 \cdot E \cdot I_b}{L_{BC}} + \frac{4 \cdot E \cdot I_c}{L_{BE}} \quad k_{23} := \frac{2 \cdot E \cdot I_b}{L_{BC}} \quad k_{24} := 0$$

$$k_{31} := 0 \quad k_{32} := \frac{2 \cdot E \cdot I_b}{L_{BC}} \quad k_{33} := \frac{4 \cdot E \cdot I_b}{L_{CD}} + \frac{4 \cdot E \cdot I_b}{L_{BC}} + \frac{4 \cdot E \cdot I_c}{L_{CF}} \quad k_{34} := \frac{2 \cdot E \cdot I_b}{L_{CD}}$$

$$k_{41} := 0 \quad k_{42} := 0 \quad k_{43} := \frac{2 \cdot E \cdot I_b}{L_{CD}} \quad k_{44} := \frac{4 \cdot E \cdot I_b}{L_{CD}}$$

$$K := \begin{bmatrix} k_{11} & k_{12} & k_{13} & k_{14} \\ k_{21} & k_{22} & k_{23} & k_{24} \\ k_{31} & k_{32} & k_{33} & k_{34} \\ k_{41} & k_{42} & k_{43} & k_{44} \end{bmatrix} = \begin{bmatrix} 7427200 & 3713600 & 0 & 0 \\ 3713600 & 15443486 & 2984143 & 0 \\ 0 & 2984143 & 15758563 & 3713600 \\ 0 & 0 & 3713600 & 7427200 \end{bmatrix} \text{ kN} \cdot \text{m}$$

$$M := E \cdot I_b \cdot K$$

$$R := \begin{bmatrix} -M \\ 0 \\ 0 \\ M \end{bmatrix} \quad r := K^{-1} \cdot R = \begin{bmatrix} -7.62 \cdot 10^{-4} \\ 2.26 \cdot 10^{-4} \\ -2.22 \cdot 10^{-4} \\ 7.6 \cdot 10^{-4} \end{bmatrix}$$

$$r_1 := r \cdot \begin{bmatrix} 1 \\ 0 \\ 0 \\ 0 \end{bmatrix} = -7.62 \cdot 10^{-4}$$

$$r_2 := r \cdot \begin{bmatrix} 0 \\ 1 \\ 0 \\ 0 \end{bmatrix} = 2.26 \cdot 10^{-4}$$

$$r_3 := r \cdot \begin{bmatrix} 0 \\ 0 \\ 1 \\ 0 \end{bmatrix} = -2.22 \cdot 10^{-4}$$

$$r_4 := r \cdot \begin{bmatrix} 0 \\ 0 \\ 0 \\ 1 \end{bmatrix} = 7.6 \cdot 10^{-4}$$

## Moments

$$M_{AB1} := k_{11} \cdot r_1 = -5660 \text{ kN}\cdot\text{m}$$

$$M_{BA1} := k_{21} \cdot r_1 = -2830 \text{ kN}\cdot\text{m}$$

$$M_{AB2} := k_{12} \cdot r_2 = 840 \text{ kN}\cdot\text{m}$$

$$M_{BA2} := r_2 \cdot \frac{E \cdot I_b \cdot 4}{L_{AB}} = 1680 \text{ kN}\cdot\text{m}$$

$$M_{BC2} := r_2 \cdot \frac{E \cdot I_b \cdot 4}{L_{BC}} = 1350 \text{ kN}\cdot\text{m}$$

$$M_{CB2} := k_{32} \cdot r_2 = 675 \text{ kN}\cdot\text{m}$$

$$M_{BE2} := r_2 \cdot \frac{E \cdot I_c \cdot 4}{L_{BE}} = 463 \text{ kN}\cdot\text{m}$$

$$M_{EB2} := r_2 \cdot \frac{E \cdot I_c \cdot 2}{L_{BE}} = 232 \text{ kN}\cdot\text{m}$$

$$M_{BC3} := k_{23} \cdot r_3 = -662 \text{ kN}\cdot\text{m}$$

$$M_{CB3} := r_3 \cdot \frac{E \cdot I_b \cdot 4}{L_{BC}} = -1324 \text{ kN}\cdot\text{m}$$

$$M_{CD3} := r_3 \cdot \frac{E \cdot I_b \cdot 4}{L_{CD}} = -1648 \text{ kN}\cdot\text{m}$$

$$M_{DC3} := k_{43} \cdot r_3 = -824 \text{ kN}\cdot\text{m}$$

$$M_{CF3} := r_3 \cdot \frac{E \cdot I_c \cdot 4}{L_{CF}} = -524 \text{ kN}\cdot\text{m}$$

$$M_{FC3} := r_3 \cdot \frac{E \cdot I_c \cdot 2}{L_{CF}} = -262 \text{ kN}\cdot\text{m}$$

$$M_{CD4} := k_{34} \cdot r_4 = 2822 \text{ kN}\cdot\text{m}$$

$$M_{DC4} := k_{44} \cdot r_4 = 5645 \text{ kN}\cdot\text{m}$$

$$M_{AB} := M + M_{AB1} + M_{AB2} = 0 \text{ kN}\cdot\text{m}$$

$$M_{BA} := -M + M_{BA1} + M_{BA2} = -5971 \text{ kN}\cdot\text{m}$$

$$M_{BC} := -M - M_{BC2} - M_{BC3} = -5508 \text{ kN}\cdot\text{m}$$

$$M_{CB} := -M + M_{CB2} + M_{CB3} = -5470 \text{ kN}\cdot\text{m}$$

$$M_{CD} := -M - M_{CD3} - M_{CD4} = -5995 \text{ kN}\cdot\text{m}$$

$$M_{DC} := -M + M_{DC3} + M_{DC4} = 0 \text{ kN}\cdot\text{m}$$

## Appendix L Verification of prestressing losses

$$f_{ck} := 45 \text{ MPa} \quad f_{ctm} := 3.8 \text{ MPa}$$

$$\alpha_{cc} := 0.85$$

$$E_c := 36000 \text{ MPa} \quad \varphi_{100} := 1.6886$$

$$\gamma_c := 1.5$$

$$\gamma_s := 1.15$$

$$\gamma_p := 1.15$$

$$f_{cd} := \alpha_{cc} \cdot \frac{f_{ck}}{\gamma_c} = 25.5 \text{ MPa}$$

$$f_{ctk.0.05} := 2.7 \text{ MPa}$$

$$f_{ctd} := \alpha_{cc} \cdot \frac{f_{ctk.0.05}}{\gamma_c} = 1.53 \text{ MPa}$$

$$f_{p.0.1k} := 1600 \text{ MPa}$$

$$f_{pk} := 1860 \text{ MPa}$$

$$f_{pd} := \frac{f_{pk}}{\gamma_p} = 1617 \text{ MPa}$$

$$E_p := 195000 \text{ MPa}$$

$$\sigma_{p0} := 0.85 \cdot f_{p.0.1k} = 1360 \text{ MPa}$$

$$\sigma_{p.max} := 0.9 \cdot f_{p.0.1k} = 1440 \text{ MPa}$$

Span

$$b_{eff} := 8.5 \text{ m}$$

$$n_{cable} := 8$$

$$COG_{z.down} := 725 \text{ mm}$$

$$COG_{z.up} := 575 \text{ mm}$$

$$A_c := 7.725 \text{ m}^2$$

$$A_{p1} := 2250 \text{ mm}^2 = 2250 \text{ mm}^2$$

$$I_c := 1.16 \text{ m}^4$$

$$A_p := n_{cable} \cdot 2250 \text{ mm}^2 = 18000 \text{ mm}^2$$

## Short-term losses

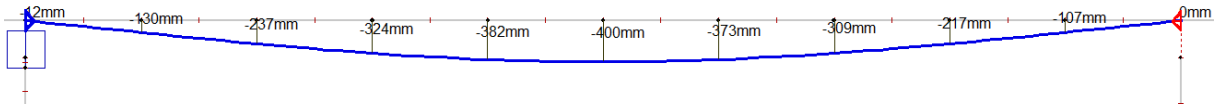

### The friction loss

Eurocode

$$L := 22.5 \text{ m} \quad \mu := 0.19$$

$$d_r := 400 \text{ mm} \quad k := 0.005$$

The total angular deviation in a parabolic curve

$$\alpha := 2 \cdot \tan\left(\frac{4 \cdot d_r}{L}\right) = 0.142$$

The radius of curvature

$$r_{ps} := \frac{L^2}{8 \cdot d_r} = 158.203 \text{ m} \quad L := \frac{L}{m}$$

Loss at the left end

$$P := 1 - e^{-\mu \cdot (\alpha + k \cdot L)} = 4.729\%$$

NovaFrame according to Eurocode - the wobble coefficient is multiply by friction coefficient

$$k := k \cdot \mu = 0.00095$$

$$P := 1 - e^{-(\mu \cdot \alpha + k \cdot L)} = 4.729\%$$

### The anchorage slip

$$k := 0.00095$$

$$p := \frac{3240 \text{ kN} \cdot \left(1 - e^{-\left(\mu \cdot \frac{m}{r_{ps}} + k\right)}\right)}{m} = 6.962 \frac{\text{kN}}{m}$$

$$x := \left(6 \text{ mm} \cdot E_p \cdot \frac{A_{p1}}{p}\right)^{0.5} = 19.446 \text{ m}$$

$$\Delta P := 2 \cdot p \cdot x = 270.752 \text{ kN}$$

$$\Delta P := \frac{\Delta P}{3240 \text{ kN}} = 8.357\%$$



## Long-term losses

### Creep

Short time

$$E_{cm} := 36000 \text{ MPa} \qquad \eta_{short} := \frac{E_p}{E_{cm}} = 5.417$$

$$A_{t.short} := A_c + (\eta_{short} - 1) \cdot A_p = 7.805 \text{ m}^2$$

$$e_{p.span} := 575 \text{ mm}$$

$$y_{t.eff} := \frac{(\eta_{short} - 1) \cdot A_p \cdot e_{p.span}}{A_{t.short}} = 5.857 \text{ mm}$$

$$I_{t.eff.span} := I_c + A_{t.short} \cdot y_{t.eff}^2 + (\eta_{short} - 1) \cdot A_p \cdot (e_{p.span} - y_{t.eff})^2 = 1.186 \text{ m}^4$$

$$N := -3240 \text{ kN} \cdot n_{cable} = -25920 \text{ kN}$$

$$M_t := N \cdot (e_{p.span} - y_{t.eff}) = -14752 \text{ kN} \cdot \text{m}$$

$$M_g := 9757 \text{ kN} \cdot \text{m}$$

$$M := M_t + M_g = -4995 \text{ kN} \cdot \text{m}$$

$$\sigma_{c.short} := \frac{N}{A_{t.short}} + \frac{M \cdot (e_{p.span} - y_{t.eff})}{I_{t.eff.span}} = -5.718 \text{ MPa}$$

Concrete strain - short time

$$\Delta \epsilon_{ps} := \frac{\sigma_{c.short}}{E_{cm}} = -1.588 \cdot 10^{-4} \qquad \Delta \sigma_{ps} := \Delta \epsilon_{ps} \cdot E_p = -30.974 \text{ MPa}$$

Long time

$$E_{cm} := \frac{E_c}{1 + \varphi_{100}} = 13390 \text{ MPa}$$

$$\eta_{long} := \frac{E_p}{E_{cm}} = 14.563$$

$$A_{t,long} := A_c + (\eta_{long} - 1) \cdot A_p = 7.969 \text{ m}^2$$

$$e_{p,span} := 575 \text{ mm}$$

$$y_{t,eff} := \frac{(\eta_{long} - 1) \cdot A_p \cdot e_{p,span}}{A_{t,long}} = 17.615 \text{ mm}$$

$$I_{t,eff,span} := I_c + A_{t,long} \cdot y_{t,eff}^2 + (\eta_{long} - 1) \cdot A_p \cdot (e_{p,span} - y_{t,eff})^2 = 1.238 \text{ m}^4$$

$$N := -3240 \text{ kN} \cdot n_{cable} = -25920 \text{ kN}$$

$$M_t := N \cdot (e_{p,span} - y_{t,eff}) = -14447 \text{ kN} \cdot \text{m}$$

$$M_g := (9757 + 1313) \text{ kN} \cdot \text{m} = 11070 \text{ kN} \cdot \text{m}$$

$$M := M_t + M_g = -3377 \text{ kN} \cdot \text{m}$$

$$\sigma_{c,short} := \frac{N}{A_{t,short}} + \frac{M \cdot (e_{p,span} - y_{t,eff})}{I_{t,eff,span}} = -4.841 \text{ MPa}$$

**Concrete strain - long time**

$$\Delta \varepsilon_{pl} := \frac{\sigma_{c,short}}{E_{cm}} = -3.616 \cdot 10^{-4}$$

$$\Delta \sigma_{pl} := \Delta \varepsilon_{pl} \cdot E_p = -70.506 \text{ MPa}$$

$$\Delta \sigma_{creep} := \Delta \sigma_{pl} - \Delta \sigma_{ps} = -39.532 \text{ MPa}$$

$$\varepsilon_{cc} := \frac{|\Delta \sigma_{creep}|}{\sigma_{p,max}} = 2.745\%$$

## Shrinkage

Shrinkage strain

$$\varepsilon_{cs} := -2.942 \cdot 10^{-4}$$

$$N_s := |\varepsilon_{cs}| \cdot E_p \cdot A_p = 1032.642 \text{ kN}$$

$$\Delta\varepsilon_{p.shrinkage} := \varepsilon_{cs} + \frac{N_s}{E_{cm} \cdot A_{t.long}} + \frac{N_s \cdot (e_{p.span} - y_{t.eff})^2}{E_{cm} \cdot I_{t.eff.span}} = -2.6517 \cdot 10^{-4}$$

$$\Delta\sigma_{p.shrinkage} := \Delta\varepsilon_{p.shrinkage} \cdot E_p = -51.709 \text{ MPa}$$

$$\varepsilon_{cs} := \frac{|\Delta\sigma_{p.shrinkage}|}{\sigma_{p.max}} = 3.591\%$$

## Relaxation

After 100 year, time in hours

$$t := 854400$$

$$\sigma_{pi} := \sigma_{p0} = 1360 \text{ MPa} \quad \mu := \frac{\sigma_{pi}}{f_{pk}} = 0.731 \quad \rho_{1000} := 2.5$$

$$\Delta\sigma_{pr} := 0.66 \cdot \rho_{1000} \cdot e^{9.1 \cdot \mu} \cdot \left(\frac{t}{1000}\right)^{0.75 \cdot (1 - \mu)} \cdot 10^{-5} \cdot \sigma_{pi} = 67.885 \text{ MPa}$$

$$\varepsilon_{rel} := \frac{\Delta\sigma_{pr}}{\sigma_{p.max}} = 4.714\%$$

According EC2, 5.10.6(1), relaxation loss is reduced by factor 0.8

$$\varepsilon_{rel} := 0.8 \cdot \varepsilon_{rel} = 3.771\%$$

## Summary of long tem losses

$$\varepsilon_{total.long} := \varepsilon_{cc} + \varepsilon_{cs} + \varepsilon_{rel} = 10.1\%$$

## Simplified method to evaluate time dependent losses

according to EC 1992-1-1, 5.10.6 (2)

$$E_{cm} := 36000 \text{ MPa}$$

$$\Delta P_{c+s+r} = A_p \Delta \sigma_{p,c+s+r} = A_p \frac{\varepsilon_{cs} E_p + 0,8 \Delta \sigma_{pr} + \frac{E_p}{E_{cm}} \varphi(t, t_0) \cdot \sigma_{c,QP}}{1 + \frac{E_p}{E_{cm}} \frac{A_p}{A_c} \left(1 + \frac{A_c}{I_c} z_{cp}^2\right) [1 + 0,8 \varphi(t, t_0)]} \quad (5.46)$$

$$\rho := 1.659$$

$$\sigma_{c,QP} := \sigma_{c,short}$$

$$z_{cp} := e_{p,span} = 0.575 \text{ m}$$

$$\Delta \sigma_{p,c.s.r} := \frac{\frac{|\varepsilon_{cs}|}{100} \cdot E_p + 0.8 \Delta \sigma_{pr} + \frac{E_p}{E_{cm}} \cdot \rho \cdot |\sigma_{c,QP}|}{1 + \frac{E_p}{E_{cm}} \cdot \frac{A_p}{A_c} \cdot \left(1 + \frac{A_c}{I_c} \cdot z_{cp}^2\right) \cdot [1 + 0.8 \cdot \rho]} = [153.409] \text{ MPa}$$

$$\varepsilon_{tot.simplified} := \frac{\Delta \sigma_{p,c.s.r}}{\sigma_{p,max}} = [10.7\%]$$

## **Appendix B**

# **Verification of prestressing losses - SCIA**

**Tendon name: TND1**

Type of history of stressing: 1

**Appendix M Verification of prestressing losses - SCIA**

Calculation of correction of stress relaxation and short-term relaxation losses from stress during correction.

Tendon stressed from it's end.

Anchorage set loss disappears along the length of tendon;

length affected: straight part : 0.000 [m]

curved part: 0.00 [deg]

Theoretical tendon elongation before transfer 0.162 [m]

Theoretical tendon elongation after transfer 0.162 [m]

x [m]	Frictional loss [MPa]	Short-term relaxation [MPa]	Stress after relaxation [MPa]	Relaxation passed [MPa]	Relax. to be passed [MPa]
0.000	-67.97	-0.47	1371.56	-3.41	0.00
0.500	-66.54	-0.48	1372.98	-3.45	0.00
1.000	-65.07	-0.49	1374.45	-3.50	0.00
1.500	-63.59	-0.49	1375.92	-3.55	0.00
2.000	-62.11	-0.50	1377.39	-3.60	0.00
2.500	-60.63	-0.50	1378.87	-3.65	0.00
3.000	-59.14	-0.51	1380.35	-3.70	0.00
3.500	-57.66	-0.52	1381.83	-3.75	0.00
4.000	-56.17	-0.52	1383.31	-3.80	0.00
4.500	-54.68	-0.53	1384.79	-3.86	0.00
5.000	-53.19	-0.54	1386.28	-3.91	0.00
5.500	-51.69	-0.54	1387.76	-3.96	0.00
6.000	-50.20	-0.55	1389.25	-4.02	0.00
6.500	-48.70	-0.56	1390.74	-4.07	0.00
7.000	-47.20	-0.57	1392.23	-4.13	0.00
7.500	-45.70	-0.57	1393.72	-4.19	0.00
8.000	-44.20	-0.58	1395.22	-4.25	0.00
8.500	-42.70	-0.59	1396.72	-4.31	0.00
9.000	-41.19	-0.60	1398.21	-4.37	0.00
9.500	-39.68	-0.60	1399.71	-4.43	0.00
10.000	-38.18	-0.61	1401.21	-4.49	0.00
10.500	-36.66	-0.62	1402.72	-4.56	0.00
11.000	-35.15	-0.63	1404.22	-4.62	0.00
11.500	-33.64	-0.64	1405.73	-4.69	0.00
12.000	-32.12	-0.64	1407.23	-4.75	0.00
12.500	-30.61	-0.65	1408.74	-4.82	0.00
13.000	-29.09	-0.66	1410.25	-4.89	0.00
13.500	-27.57	-0.67	1411.76	-4.96	0.00
14.000	-26.05	-0.68	1413.28	-5.03	0.00
14.500	-24.52	-0.69	1414.79	-5.10	0.00
15.000	-23.00	-0.70	1416.31	-5.17	0.00
15.500	-21.47	-0.71	1417.82	-5.25	0.00
16.000	-19.94	-0.72	1419.34	-5.32	0.00
16.500	-18.41	-0.73	1420.86	-5.40	0.00
17.000	-16.88	-0.74	1422.38	-5.48	0.00
17.500	-15.35	-0.75	1423.90	-5.56	0.00
18.000	-13.82	-0.76	1425.43	-5.64	0.00
18.500	-12.28	-0.77	1426.95	-5.72	0.00
19.000	-10.74	-0.78	1428.48	-5.80	0.00
19.500	-9.21	-0.79	1430.00	-5.89	0.00
20.000	-7.67	-0.80	1431.53	-5.97	0.00
20.500	-6.13	-0.81	1433.06	-6.06	0.00
21.000	-4.59	-0.82	1434.59	-6.15	0.00
21.500	-3.04	-0.84	1436.12	-6.23	0.00
22.000	-1.50	-0.85	1437.66	-6.33	0.00
22.500	0.00	-0.86	1439.14	-6.41	0.00

**Tendon name: TND1**

Type of history of stressing: 1

Calculation of frictional, anchorage set and long-term relaxation losses from initial tendon stress.

Tendon stressed from it's end.

Anchorage set loss disappears along the length of tendon;

length affected: straight part : 19.836 [m]

curved part: 7.18 [deg]

Theoretical tendon elongation before transfer 0.162 [m]

Theoretical tendon elongation after transfer 0.156 [m]

x [m]	Frictional loss [MPa]	Anchorage set loss [MPa]	Short-term relaxation [MPa]	Stress after anchoring / transfer [MPa]	Relaxation passed [MPa]	Relax. to be passed [MPa]
0.000	-67.97	0.00	-0.47	1372.03	-3.41	-59.86
0.500	-66.54	0.00	-0.48	1373.46	-3.45	-60.09
1.000	-65.07	0.00	-0.49	1374.93	-3.50	-60.34
1.500	-63.59	0.00	-0.49	1376.41	-3.55	-60.58
2.000	-62.11	0.00	-0.50	1377.89	-3.60	-60.83
2.500	-60.63	0.00	-0.50	1379.37	-3.65	-61.08
3.000	-59.14	-2.00	-0.51	1378.86	-3.70	-60.93
3.500	-57.66	-4.96	-0.52	1377.38	-3.75	-60.58

x [m]	Frictional loss [MPa]	Anchorage set loss [MPa]	Short-term relaxation [MPa]	Stress after anchoring / transfer [MPa]	Relaxation passed [MPa]	Relax. to be passed [MPa]
4.000	-56.17	-7.93	-0.52	1375.90	-3.80	-60.23
4.500	-54.68	-10.90	-0.53	1374.42	-3.86	-59.88
5.000	-53.19	-13.87	-0.54	1372.94	-3.91	-59.53
5.500	-51.69	-16.84	-0.54	1371.46	-3.96	-59.19
6.000	-50.20	-19.81	-0.55	1369.99	-4.02	-58.84
6.500	-48.70	-22.78	-0.56	1368.52	-4.07	-58.50
7.000	-47.20	-25.75	-0.57	1367.04	-4.13	-58.16
7.500	-45.70	-28.72	-0.57	1365.57	-4.19	-57.81
8.000	-44.20	-31.70	-0.58	1364.10	-4.25	-57.47
8.500	-42.70	-34.67	-0.59	1362.63	-4.31	-57.13
9.000	-41.19	-37.64	-0.60	1361.17	-4.37	-56.79
9.500	-39.68	-40.61	-0.60	1359.70	-4.43	-56.45
10.000	-38.18	-43.59	-0.61	1358.24	-4.49	-56.11
10.500	-36.66	-46.56	-0.62	1356.78	-4.56	-55.77
11.000	-35.15	-49.53	-0.63	1355.32	-4.62	-55.43
11.500	-33.64	-52.50	-0.64	1353.86	-4.69	-55.09
12.000	-32.12	-55.48	-0.64	1352.40	-4.75	-54.75
12.500	-30.61	-58.45	-0.65	1350.95	-4.82	-54.41
13.000	-29.09	-61.42	-0.66	1349.49	-4.89	-54.08
13.500	-27.57	-64.39	-0.67	1348.04	-4.96	-53.74
14.000	-26.05	-67.37	-0.68	1346.59	-5.03	-53.40
14.500	-24.52	-70.34	-0.69	1345.14	-5.10	-53.07
15.000	-23.00	-73.31	-0.70	1343.69	-5.17	-52.73
15.500	-21.47	-76.28	-0.71	1342.24	-5.25	-52.39
16.000	-19.94	-79.26	-0.72	1340.80	-5.32	-52.06
16.500	-18.41	-82.23	-0.73	1339.36	-5.40	-51.72
17.000	-16.88	-85.20	-0.74	1337.92	-5.48	-51.39
17.500	-15.35	-88.17	-0.75	1336.48	-5.56	-51.05
18.000	-13.82	-91.14	-0.76	1335.04	-5.64	-50.72
18.500	-12.28	-94.11	-0.77	1333.61	-5.72	-50.39
19.000	-10.74	-97.08	-0.78	1332.17	-5.80	-50.05
19.500	-9.21	-100.05	-0.79	1330.74	-5.89	-49.72
20.000	-7.67	-103.02	-0.80	1329.31	-5.97	-49.38
20.500	-6.13	-105.99	-0.81	1327.88	-6.06	-49.05
21.000	-4.59	-108.96	-0.82	1326.46	-6.15	-48.71
21.500	-3.04	-111.93	-0.84	1325.03	-6.23	-48.38
22.000	-1.50	-114.90	-0.85	1323.61	-6.33	-48.05
22.500	0.00	-117.77	-0.86	1322.23	-6.41	-47.72

x [m]	y [m]	z [m]	Maximum stress after transfer [MPa]
2.500	0.000	-0.158	1379.37

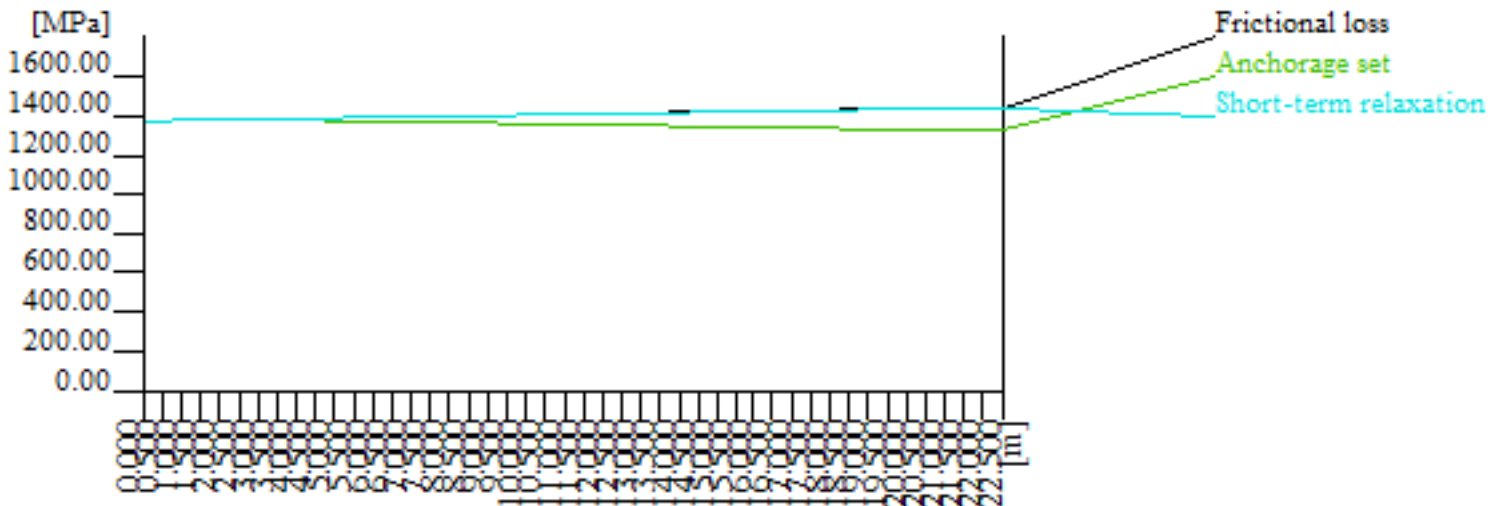





## Appendix N

### Effective flange width

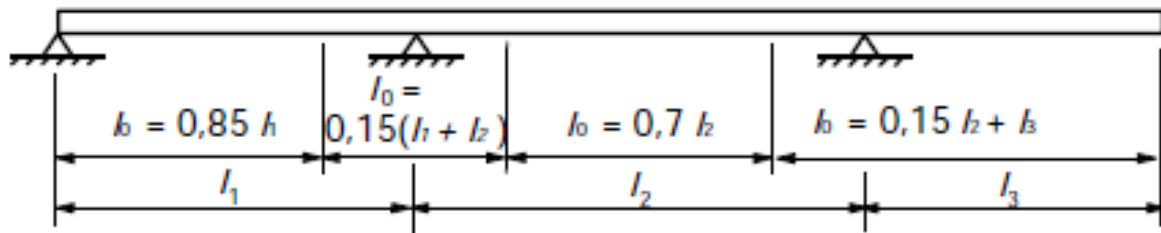

$$b_w = 5 \text{ m}$$

$$b_{1,2} = 1,75 \text{ m}$$

$$b_{total} = 8,5 \text{ m}$$

$$l_1 = 22,5 \text{ m}$$

$$l_2 = 28,0 \text{ m}$$

#### In the midspan 1

$$l_0 = 0,85 * l_1 = 19,125 \text{ m}$$

$$b_{eff,1,2} = 0,2 * b_{1,2} + 0,1 * l_1 = 0,2 * 1,75 + 0,1 * 22,5 = 2,6 \text{ m}$$

$$b_{eff} = b_w + 2 * b_{eff} = 5 + 2 * 2,6 = 10,2 \text{ m}$$

$$b_w = 5 \text{ m}$$

$$b_{1,2} = 1,75 \text{ m}$$

$$b_{total} = 8,5 \text{ m}$$

$$l_1 = 22,5 \text{ m}$$

$$l_2 = 28,0 \text{ m}$$

#### In the midspan 1

$$l_0 = 0,85 * l_1 = 0,85 * 22,5 = 19,125 \text{ m}$$

$$b_{eff,1,2} = 0,2 * b_{1,2} + 0,1 * l_1 = 0,2 * 1,75 + 0,1 * 19,125 = 2,2625 \text{ m}$$

$$b_{eff} = b_w + 2 * b_{eff,1,2} = 5 + 2 * 2,2625 = 9,525 \text{ m}$$

$$b_{eff} \leq b_{total}$$

$$b_{eff} = 8,5 \text{ m}$$

**In the midspan 2**

$$l_0 = 0,7 * l_2 = 0,7 * 28 = 19,6 \text{ m}$$

$$b_{eff,1,2} = 0,2 * b_{1,2} + 0,1 * l_1 = 0,2 * 1,75 + 0,1 * 19,6 = 2,31 \text{ m}$$

$$b_{eff} = b_w + 2 * b_{eff,1,2} = 5 + 2 * 2,31 = 9,62 \text{ m}$$

$$b_{eff} \leq b_{total}$$

$$b_{eff} = 8,5 \text{ m}$$

**Over the support**

$$l_0 = 0,15 * (l_1 + l_2) = 0,15 * (22,5 + 28) = 7,575 \text{ m}$$

$$b_{eff,1,2} = 0,2 * b_{1,2} + 0,1 * l_1 = 0,2 * 1,75 + 0,1 * 7,575 = 1,1075 \text{ m}$$

$$b_{eff} = b_w + 2 * b_{eff,1,2} = 5 + 2 * 1,1075 = 7,215 \text{ m}$$

$$b_{eff} \leq b_{total}$$

$$b_{eff} = 7,215 \text{ m}$$

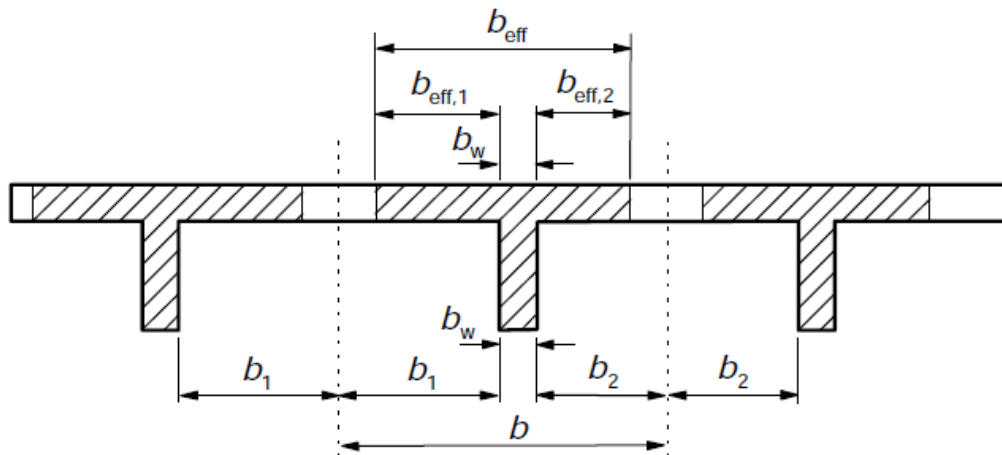

Figure 1

## Appendix O Ultimate limit state (ULS)

$$f_{ck} := 45 \text{ MPa}$$

$$\alpha_{cc} := 0.85$$

$$\gamma_c := 1.5$$

$$\gamma_s := 1.15$$

$$\gamma_p := 1.15$$

$$f_{cd} := \alpha_{cc} \cdot \frac{f_{ck}}{\gamma_c} = 25.5 \text{ MPa}$$

$$f_{ctk.0.05} := 2.7 \text{ MPa}$$

$$f_{ctd} := \alpha_{cc} \cdot \frac{f_{ctk.0.05}}{\gamma_c} = 1.53 \text{ MPa}$$

$$f_{p.0.1k} := 1600 \text{ MPa}$$

$$f_{pk} := 1860 \text{ MPa}$$

$$f_{pd} := \frac{f_{pk}}{\gamma_p} = 1617 \text{ MPa}$$

$$E_p := 195000 \text{ MPa}$$

$$\sigma_{p.max} := 0.9 \cdot f_{p.0.1k} = 1440 \text{ MPa}$$

$$\sigma_{p0} := 0.85 \cdot f_{p.0.1k} = 1360 \text{ MPa}$$

$$A_{cable} := 2250 \text{ mm}^2$$

$$h := 1.3 \text{ m}$$

$$h_{flange} := 0.35 \text{ m}$$

$$A_c := 7.725 \text{ m}^2$$

$$b_{web} := 5 \text{ m}$$

Span

$$b_{eff} := 8.5 \text{ m}$$

$$COG_{z.down} := 725 \text{ mm}$$

$$COG_{z.up} := 575 \text{ mm}$$

Support

$$b_{eff.support} := 7.215 \text{ m}$$

$$COG_{s.z.down} := 702 \text{ mm}$$

$$COG_{s.z.up} := 598 \text{ mm}$$

$$\varepsilon_{cu} := 0.0035$$

$$\varepsilon_{p0} := \frac{\sigma_{p0}}{E_p} = 6.974 \cdot 10^{-3}$$

Long-term losses

$$\varepsilon_{loss} := 10.1\%$$

$$\varepsilon'_{p0} := \varepsilon_{p0} - \varepsilon_{loss} \cdot \varepsilon_{p0} = 6.27 \cdot 10^{-3}$$

$$\alpha_b := \frac{\varepsilon_{cu}}{\frac{f_{pd}}{E_p} + -\varepsilon'_{p0} + \varepsilon_{cu}} = 0.634$$

$$\Delta\varepsilon_p := \frac{f_{pd}}{E_p} + -\varepsilon'_{p0} = 2.024 \cdot 10^{-3}$$

## Over support

$$n_{sup} := 10$$

$$c_{nom} := 125 \text{ mm}$$

$$d_{sup} := h - c_{nom} - \frac{duct}{2} = 1125 \text{ mm}$$

$$duct := 100 \text{ mm}$$

$$A_{pb.sup} := 0.8 \cdot \frac{f_{cd}}{f_{pd}} \cdot \alpha_b \cdot b_{web} \cdot d_{sup} = 44949 \text{ mm}^2$$

$$A_{p.sup} := n_{sup} \cdot A_{cable} = 22500 \text{ mm}^2$$

$$check := \begin{cases} \text{if } A_{pb.sup} \geq A_{p.sup} \\ \quad \text{“Under-reinforced”} \\ \text{else} \\ \quad \text{“Over-reinforced”} \end{cases} = \text{“Under-reinforced”}$$

$$\alpha_{sup} := \frac{A_{p.sup} \cdot f_{pd}}{0.8 \cdot f_{cd} \cdot b_{web} \cdot d_{sup}} = 0.317$$

$$M_{Rd.sup} := 0.8 \cdot \alpha_{sup} \cdot (1 - 0.4 \cdot \alpha_{sup}) \cdot f_{cd} \cdot b_{web} \cdot d_{sup}^2 = 35747 \text{ kN} \cdot \text{m}$$

$$M_{Ed.sup} := 26342 \text{ kN} \cdot \text{m}$$

Element 210

$$capacity := \begin{cases} \text{if } M_{Rd.sup} \geq M_{Ed.sup} \\ \quad \text{“Capacity OK”} \\ \text{else} \\ \quad \text{“!!Capacity NOT OK!!”} \end{cases} = \text{“Capacity OK”}$$

## Check in middle span

$$n_{span2} := 8$$

$$c_{nom} := 100 \text{ mm}$$

$$d_{span2} := h - c_{nom} - \frac{duct}{2} = 1150 \text{ mm}$$

$$duct := 100 \text{ mm}$$

$$A_{pb.span2} := 0.8 \cdot \frac{f_{cd}}{f_{pd}} \cdot \alpha_b \cdot b_{web} \cdot d_{span2} = 45948 \text{ mm}^2$$

$$A_{p.span2} := n_{span2} \cdot A_{cable} = 18000 \text{ mm}^2$$

$$check := \begin{cases} \text{if } A_{pb.span2} \geq A_{p.span2} \\ \quad \text{"Under-reinforced"} \\ \text{else} \\ \quad \text{"Over-reinforced"} \end{cases} = \text{"Under-reinforced"}$$

$$\alpha_{span.2} := \frac{A_{p.span2} \cdot f_{pd}}{0.8 \cdot f_{cd} \cdot b_{eff} \cdot d_{span2}} = 0.146$$

$$t := 0.8 \cdot \alpha_{span.2} \cdot d_{span2} = 0.134 \text{ m } t \leq 350 \text{ mm}$$

can be calculated with  $b_{eff}$

$$M_{Rd.span2} := 0.8 \cdot \alpha_{span.2} \cdot (1 - 0.4 \cdot \alpha_{span.2}) \cdot f_{cd} \cdot b_{eff} \cdot d_{span2}^2 = 31525 \text{ kN}\cdot\text{m}$$

$$M_{Ed.span2} := 25571 \text{ kN}\cdot\text{m}$$

Element 290

$$capacity := \begin{cases} \text{if } M_{Rd.span2} \geq M_{Ed.span2} \\ \quad \text{"Capacity OK"} \\ \text{else} \\ \quad \text{"!!Capacity NOT OK!!"} \end{cases} = \text{"Capacity OK"}$$

## Check in side span

$$n_{span1} := 6$$

$$c_{nom} := 100 \text{ mm}$$

$$d_{span1} := h - c_{nom} - \frac{duct}{2} = 1150 \text{ mm}$$

$$duct := 100 \text{ mm}$$

$$A_{pb.span1} := 0.8 \cdot \frac{f_{cd}}{f_{pd}} \cdot \alpha_b \cdot b_{web} \cdot d_{span1} = 45948 \text{ mm}^2$$

$$A_{p.span1} := n_{span1} \cdot A_{cable} = 13500 \text{ mm}^2$$

$$check := \begin{cases} \text{if } A_{pb.span1} \geq A_{p.span1} \\ \quad \text{|| "Under-reinforced"} \\ \quad \text{|| else} \\ \quad \text{|| "Over-reinforced"} \end{cases} = \text{"Under-reinforced"}$$

$$\alpha_{span.1} := \frac{A_{p.span1} \cdot f_{pd}}{0.8 \cdot f_{cd} \cdot b_{eff} \cdot d_{span1}} = 0.109$$

$$t := 0.8 \cdot \alpha_{span.1} \cdot d_{span1} = 0.101 \text{ m } t \leq 350 \text{ mm}$$

can be calculated with  $b_{eff}$

$$M_{Rd.span1} := 0.8 \cdot \alpha_{span.1} \cdot (1 - 0.4 \cdot \alpha_{span.1}) \cdot f_{cd} \cdot b_{eff} \cdot d_{span1}^2 = 24010 \text{ kN}\cdot\text{m}$$

$$M_{Ed.span1} := 20813 \text{ kN}\cdot\text{m}$$

Element 150

$$capacity := \begin{cases} \text{if } M_{Rd.span1} \geq M_{Ed.span1} \\ \quad \text{|| "Capacity OK"} \\ \quad \text{|| else} \\ \quad \text{|| "!!Capacity NOT OK!!"} \end{cases} = \text{"Capacity OK"}$$

## Shear capacity

$$d_{sh} := 1150 \text{ mm}$$

In distance  $d$  from axis 3

$$V_{Ed.380.0} := 5983 \text{ kN}$$

$$d_{380} := 1866 \text{ mm}$$

$$V_{Ed.380.1} := 5355 \text{ kN}$$

$$V_{Ed} := \frac{V_{Ed.380.0} - V_{Ed.380.1}}{d_{380}} \cdot d_{sh} + V_{Ed.380.1} = 5742 \text{ kN}$$

$$N_{Ed} := 26499 \text{ kN}$$

## Members not requiring design shear reinforcement check

$$k := 1 + \sqrt{\frac{200 \text{ mm}}{d_{sh}}} = 1.417$$

$$\rho_1 := \frac{A_{p.sup}}{b_{web} \cdot d_{sh}} = 0.004$$

$$k_1 := 0.15$$

$$k_2 := 0.18 \quad (\text{NA6.2.2})$$

$$C_{Rd.c} := \frac{k_2}{\gamma_c} = 0.12$$

$$\sigma_{cp} := \frac{N_{Ed}}{A_c} = 3.43 \text{ MPa} \quad \text{less than} \quad 0.2 \cdot f_{cd} = 5.1 \text{ MPa}$$

$$V_{min} := 0.035 \cdot \frac{f_{ck}^{0.5}}{\text{MPa}^{-0.5}} = 0.044 \text{ MPa}$$

$$V_{Rd.c.min} := (V_{min} + \sigma_{cp} \cdot k_1) \cdot b_{web} \cdot d_{sh} = 3211 \text{ kN}$$

$$V_{Rd.c} := \left( C_{Rd.c} \cdot k \cdot \left( 100 \cdot \rho_1 \cdot \frac{f_{ck}}{\text{MPa}} \right)^{\frac{1}{3}} \cdot \text{MPa} + k_1 \cdot \sigma_{cp} \right) \cdot b_{web} \cdot d_{sh} = 5502 \text{ kN}$$

$$V_{Rd.c} := \max(V_{Rd.c.min}, V_{Rd.c}) = 5502 \text{ kN}$$

$$\text{capacity} := \begin{cases} \text{if } V_{Rd.c} \geq V_{Ed} \\ \quad \text{“no need of shear reinforcement”} \\ \text{else} \\ \quad \text{“!!design shear reinforcement!!”} \end{cases} = \text{“!!design shear reinforcement!!”}$$

Calculations with minimal longitudinal reinforcement follow below

## Members requiring design shear reinforcement

Where the web contains grouted ducts with a diameter  $\phi > b_w/8$  the shear resistance  $V_{Rd,max}$  should be calculated on the basis of a nominal web thickness given by:

$$b_{w,nom} = b_w - 0,5 \sum \phi \quad b_w := b_{web} = 5 \text{ m}$$

$$b_{w,nom} := b_w - 0,5 \cdot 10 \cdot 100 \text{ mm} = 4,5 \text{ m}$$

For members with vertical shear reinforcement, the shear resistance,  $V_{Rd}$  is the smaller value of:

$$V_{Rd,s} = \frac{A_{sw}}{s} z f_{ywd} \cot \theta \quad (6.8)$$

$$V_{Rd,max} = \alpha_{cw} b_w z v_1 f_{cd} / (\cot \theta + \tan \theta) \quad (6.9)$$

$$d := 1150 \text{ mm} \quad A_{sw} := 6703 \text{ mm}^2$$

$$z := 0,9 \cdot d = 1035 \text{ mm} \quad f_{ywd} := 434 \text{ MPa}$$

$$s := 300 \text{ mm} \quad \cot \theta := 2$$

$$V_{rd,s} := \frac{A_{sw}}{s} \cdot z \cdot f_{ywd} \cdot \cot \theta = 20072,804 \text{ kN}$$

$$\alpha_{cw} := 1 + \frac{\sigma_{cp}}{f_{cd}} = 1,135$$

$$v_1 := 0,6$$

The angle between the concrete compression strut and the beam axis perpendicular to the shear force

$$\tan \theta := \frac{1}{\cot \theta} = 0,5$$

$$V_{Rd,max} := \frac{\alpha_{cw} \cdot b_{w,nom} \cdot z \cdot v_1 \cdot f_{cd}}{\cot \theta + \tan \theta} = 32338,28 \text{ kN}$$

$$V_{Rd} := \min(V_{Rd,max}, V_{rd,s}) = 20072,804 \text{ kN}$$

$$\text{capacity} := \begin{cases} \text{if } V_{Rd} \geq V_{Ed} \\ \quad \text{"Capacity ok"} \\ \text{else} \\ \quad \text{"!!design more shear reinforcement!!"} \end{cases} = \text{"Capacity ok"}$$



Assume 25 bars from minimum reinforcement to have effect in shear resistance

$$k := 1 + \sqrt{\frac{200 \text{ mm}}{d_{sh}}} = 1.417 \quad A_s := 25 \left( \frac{25 \text{ mm}}{2} \right)^2 \cdot \pi = 0.012 \text{ m}^2$$

$$\rho_1 := \frac{A_{p.sup} + A_s}{b_{web} \cdot d_{sh}} = 0.006$$

$$k_1 := 0.15$$

$$k_2 := 0.18 \quad (\text{NA6.2.2})$$

$$C_{Rd.c} := \frac{k_2}{\gamma_c} = 0.12$$

$$\sigma_{cp} := \frac{N_{Ed}}{A_c} = 3.43 \text{ MPa} \quad \text{less than} \quad 0.2 \cdot f_{cd} = 5.1 \text{ MPa}$$

$$v_{min} := 0.035 \cdot \frac{f_{ck}^{0.5}}{\text{MPa}^{-0.5}} = 0.044 \text{ MPa}$$

$$V_{Rd.c.min} := (v_{min} + \sigma_{cp} \cdot k_1) \cdot b_{web} \cdot d_{sh} = 3211 \text{ kN}$$

$$V_{Rd.c} := \left( C_{Rd.c} \cdot k \cdot \left( 100 \cdot \rho_1 \cdot \frac{f_{ck}}{\text{MPa}} \right)^{\frac{1}{3}} \cdot \text{MPa} + k_1 \cdot \sigma_{cp} \right) \cdot b_{web} \cdot d_{sh} = 5900 \text{ kN}$$

$$V_{Rd.c} := \max(V_{Rd.c.min}, V_{Rd.c}) = 5900 \text{ kN}$$

$$\text{capacity} := \begin{cases} \text{if } V_{Rd.c} \geq V_{Ed} \\ \quad \text{"no need of shear reinforcement"} \\ \text{else} \\ \quad \text{"!!design shear reinforcement!!"} \end{cases} = \text{"no need of shear reinforcement"}$$

**Minimal axial force max shear force**

$$V_{Ed} := 3851 \text{ kN}$$

$$N_{Ed} := 16382 \text{ kN}$$

$$\sigma_{cp} := \frac{N_{Ed}}{A_c} = 2.121 \text{ MPa} \quad \text{less than} \quad 0.2 \cdot f_{cd} = 5.1 \text{ MPa}$$

$$v_{min} := 0.035 \cdot \frac{f_{ck}^{0.5}}{\text{MPa}^{-0.5}} = 0.044 \text{ MPa}$$

$$V_{Rd.c.min} := (v_{min} + \sigma_{cp} \cdot k_1) \cdot b_{web} \cdot d_{sh} = 2082 \text{ kN}$$

$$V_{Rd.c} := \left( C_{Rd.c} \cdot k \cdot \left( 100 \cdot \rho_1 \cdot \frac{f_{ck}}{\text{MPa}} \right)^{\frac{1}{3}} \cdot \text{MPa} + k_1 \cdot \sigma_{cp} \right) \cdot b_{web} \cdot d_{sh} = 4770 \text{ kN}$$

$$V_{Rd.c} := \max(V_{Rd.c.min}, V_{Rd.c}) = 4770 \text{ kN}$$

$$\text{capacity} := \begin{cases} \text{if } V_{Rd.c} \geq V_{Ed} \\ \quad \text{"no need of shear reinforcement"} \\ \text{else} \\ \quad \text{"!!design shear reinforcement!!"} \end{cases} = \text{"no need of shear reinforcement"}$$

## Shear between web and flanges of T-sections

see transverse direction check

### Transverse direction

$$A_{cable} := 300 \text{ mm}^2$$

2 Cables for 1bm

$$n_{tra} := 2 \quad d_{tra} := 245 \text{ mm} \quad h_{tra} := 350 \text{ mm} \quad b_{tra} := 1 \text{ m}$$

$$\varepsilon_{cu} := 0.0035 \quad \varepsilon_{p0} := \frac{\sigma_{p0}}{E_p} = 6.974 \cdot 10^{-3}$$

$$\varepsilon_{loss} := 10\% \quad \varepsilon'_{p0} := \varepsilon_{p0} - \varepsilon_{loss} \cdot \varepsilon_{p0} = 6.277 \cdot 10^{-3}$$

$$\alpha_b := \frac{\varepsilon_{cu}}{\frac{f_{pd}}{E_p} + -\varepsilon'_{p0} + \varepsilon_{cu}} = 0.634$$

$$\Delta\varepsilon_p := \frac{f_{pd}}{E_p} + -\varepsilon'_{p0} = 2.017 \cdot 10^{-3}$$

$$A_{pb.tra} := 0.8 \cdot \frac{f_{cd}}{f_{pd}} \cdot \alpha_b \cdot b_{tra} \cdot d_{tra} = 1960 \text{ mm}^2$$

$$A_{p.tra} := n_{tra} \cdot A_{cable} = 600 \text{ mm}^2$$

$$check := \begin{cases} \text{if } A_{pb.tra} \geq A_{p.tra} \\ \quad \text{“Under-reinforced”} \\ \text{else} \\ \quad \text{“Over-reinforced”} \end{cases} = \text{“Under-reinforced”}$$

$$\alpha_{tra} := \frac{A_{p.tra} \cdot f_{pd}}{0.8 \cdot f_{cd} \cdot d_{tra} \cdot b_{tra}} = 0.194$$

$$M_{Rd.tra} := 0.8 \cdot \alpha_{tra} \cdot (1 - 0.4 \cdot \alpha_{tra}) \cdot f_{cd} \cdot b_{tra} \cdot d_{tra}^2 = 219 \text{ kN}\cdot\text{m}$$

$$M_{Ed.tra} := 169.8 \text{ kN}\cdot\text{m}$$

$$capacity := \begin{cases} \text{if } M_{Rd.tra} \geq M_{Ed.tra} \\ \quad \text{“Capacity OK”} \\ \text{else} \\ \quad \text{“!!Capacity NOT OK!!”} \end{cases} = \text{“Capacity OK”}$$

**Shear calculation according EN 1992 6.2.2**

$$V_{Ed} := 197.4 \text{ kN}$$

Assume 2 cables 6802 for 1 m and 15% loss (5% short-term, 10% long-term)

$$N_{Ed} := \sigma_{p,max} \cdot A_{p,tra} \cdot 0.85 = 734 \text{ kN}$$

**Members not requiring design shear reinforcement check**

$$k := 1 + \sqrt{\frac{200 \text{ mm}}{d_{tra}}} = 1.904$$

$$A_{c,t} := 0.35 \text{ m} \cdot 1 \text{ m} = 0.35 \text{ m}^2$$

$$\rho_1 := \frac{A_{p,tra}}{b_{tra} \cdot d_{tra}} = 0.002$$

$$k_1 := 0.15$$

$$k_2 := 0.18 \quad (\text{NA6.2.2})$$

$$C_{Rd,c} := \frac{k_2}{\gamma_c} = 0.12$$

$$\sigma_{cp} := \frac{N_{Ed}}{A_{c,t}} = 2.098 \text{ MPa} \quad \text{less than} \quad 0.2 \cdot f_{cd} = 5.1 \text{ MPa}$$

$$v_{min} := 0.035^{\frac{3}{2}} \cdot \frac{f_{ck}^{0.5}}{\text{MPa}^{-0.5}} = 0.044 \text{ MPa}$$

$$V_{Rd,c,min} := (v_{min} + \sigma_{cp} \cdot k_1) \cdot 1 \text{ m} \cdot d_{tra} = 88 \text{ kN}$$

$$V_{Rd,c} := \left( C_{Rd,c} \cdot k \cdot \left( 100 \cdot \rho_1 \cdot \frac{f_{ck}}{\text{MPa}} \right)^{\frac{1}{3}} \cdot \text{MPa} + k_1 \cdot \sigma_{cp} \right) \cdot 1 \text{ m} \cdot d_{tra} = 202 \text{ kN}$$

$$V_{Rd,c} := \max(V_{Rd,c,min}, V_{Rd,c}) = 202 \text{ kN}$$

$$\text{capacity} := \begin{cases} \text{if } V_{Rd,c} \geq V_{Ed} \\ \quad \text{"no need of shear reinforcement"} \\ \text{else} \\ \quad \text{"!!design shear reinforcement!!"} \end{cases} = \text{"no need of shear reinforcement"}$$

**Shear calculation according EN 1992 (6.4) for transverse direction**

$$I := \frac{m \cdot (0.35 \text{ m})^3}{12} = 0.004 \text{ m}^4$$

$$S := \frac{(0.35 \text{ m}) \cdot m \cdot (0.35 \text{ m})}{2} = 0.031 \text{ m}^3$$

$$V_{Rd.c} := \frac{I \cdot m}{S} \cdot \sqrt{f_{ctd}^2 + 1 \cdot \sigma_{cp} \cdot f_{ctd}} = 274.88 \text{ kN}$$

**Shear at the interface between concrete cast at different times****According EC 1992 6.2.5**

element 240 x=0

$$V_{Ed} := 3829 \text{ kN}$$

$$N_{Ed} := 19747 \text{ kN}$$

$$A_I := A_c = 7.725 \text{ m}^2$$

$$A_S := A_{cable} \cdot 8 = (2.4 \cdot 10^3) \text{ mm}^2$$

$$\rho := \frac{A_S}{A_I} = 3.107 \cdot 10^{-4}$$

$$\sigma_n := \frac{N_{Ed}}{A_I} = 2.556 \text{ MPa}$$

$$\beta := 1 \quad z := 1000 \text{ mm} \quad b_I := 8500 \text{ mm}$$

$$v_{EdI} := \frac{\beta \cdot V_{Ed}}{z \cdot b_I} = 0.45 \text{ MPa}$$

$$c := 0.45 \quad f_{yd} := 0 \text{ MPa}$$

$$\mu := 0.7$$

$$v_{Rdi1} := c \cdot f_{ctd} + \mu \cdot \sigma_n + \rho \cdot f_{yd} \cdot \mu = 2.478 \text{ MPa}$$

$$v := 0.6 \cdot \left( 1 - \frac{f_{ck}}{250 \text{ MPa}} \right) = 0.492$$

$$v_{Rdi2} := 0.5 \cdot v \cdot f_{cd} = 6.273 \text{ MPa}$$

$$v_{Rdi} := \min(v_{Rdi1}, v_{Rdi2}) = 2.478 \text{ MPa}$$

$$v_{Rdi} \geq v_{EdI}$$

Capacity OK

## Torsion

Torsion design moment

$$T_{Ed} := 4628 \text{ kN}\cdot\text{m}$$

The flange height and width are correspondingly small to the rest of the cross-section. For simplification only rectangular cross-section is assumed.

$$b := b_{web} = 5 \text{ m} \quad h := 1.3 \text{ m}$$

Total area of the cross-section

$$A := b \cdot h = 6.5 \text{ m}^2$$

Perimeter of the area

$$u := (b + h) \cdot 2 = 12.6 \text{ m}$$

Effective wall thickness

$$t_{ef} := \frac{A}{u} = 0.516 \text{ m}$$

Area enclosed by the centre-lines

$$A_k := (b - t_{ef}) \cdot (h - t_{ef}) = 3.516 \text{ m}^2$$

The angle of compression struts 45 degrees

$$T_{Rd,max} := 2 \cdot v \cdot \alpha_{cw} \cdot f_{cd} \cdot A_k \cdot t_{ef} \cdot \sin\left(\frac{\pi}{4}\right) \cdot \cos\left(\frac{\pi}{4}\right) = 25818.144 \text{ kN}\cdot\text{m}$$

The maximum resistance of a member subjected to torsion and shear is limited by the capacity of the concrete struts

$$\frac{T_{Ed}}{T_{Rd,max}} + \frac{V_{Ed}}{V_{Rd,max}} \leq 1,0 \quad (6.29)$$

$$V_{Rd,max} = 32338.28 \text{ kN}$$

$$V_{Ed} := 5742 \text{ kN}$$

$$\text{torsion.check} := \frac{T_{Ed}}{T_{Rd,max}} + \frac{V_{Ed}}{V_{Rd,max}} = 0.357 \quad 0.357 \leq 1$$

$$T_t := f_{ctd} = 1.53 \text{ MPa}$$

$$T_{Rd,c} := 2 \cdot T_t \cdot t_{ef} \cdot A_k = 5550.454 \text{ kN}\cdot\text{m}$$

For approximately rectangular solid sections only minimum reinforcement is required

$$T_{Ed} / T_{Rd,c} + V_{Ed} / V_{Rd,c} \leq 1,0$$

$$tension.reinforcement := \frac{T_{Ed}}{T_{Rd,c}} = 0.834 \quad 0.834 \leq 1$$

There is no any requirement for torsion reinforcement





## Appendix P Serviceability limit state (SLS)

$$f_{ck} := 45 \text{ MPa} \quad f_{ctm} := 3.8 \text{ MPa}$$

$$\alpha_{cc} := 0.85$$

$$E_c := 36000 \text{ MPa} \quad \varphi_{100} := 1.6886$$

$$E_{cm} := \frac{E_c}{1 + \varphi_{100}} = 13390 \text{ MPa}$$

$$\gamma_c := 1.5$$

$$\gamma_s := 1.15$$

$$\gamma_p := 1.15$$

$$f_{cd} := \alpha_{cc} \cdot \frac{f_{ck}}{\gamma_c} = 25.5 \text{ MPa}$$

$$f_{ctk.0.05} := 2.7 \text{ MPa}$$

$$f_{ctd} := \alpha_{cc} \cdot \frac{f_{ctk.0.05}}{\gamma_c} = 1.53 \text{ MPa}$$

$$f_{p.0.1k} := 1600 \text{ MPa}$$

$$f_{pk} := 1860 \text{ MPa}$$

$$f_{pd} := \frac{f_{pk}}{\gamma_p} = 1617 \text{ MPa}$$

$$E_p := 195000 \text{ MPa} \quad E_s := 200 \text{ GPa}$$

$$\sigma_{p0} := 0.85 \cdot f_{p.0.1k} = 1360 \text{ MPa}$$

$$\sigma_{p.max} := 0.9 \cdot f_{p.0.1k} = 1440 \text{ MPa}$$

$$\eta := \frac{E_p}{E_{cm}} = 14.563 \quad \varepsilon_{c.s} := 2.942 \cdot 10^{-4}$$

$$h := 1.3 \text{ m}$$

$$h_{flange} := 0.35 \text{ m}$$

$$b_{web} := 5 \text{ m}$$

Span

$$b_{eff} := 8.5 \text{ m}$$

Support

$$b_{eff.support} := 7.215 \text{ m}$$

$$COG_{z.down} := 725 \text{ mm}$$

$$COG_{s.z.down} := 702 \text{ mm}$$

$$COG_{z.up} := 575 \text{ mm}$$

$$COG_{s.z.up} := 598 \text{ mm}$$

## Over support in axis 2

$$A_{\text{eff.support}} := b_{\text{eff.support}} \cdot h_{\text{flange}} + b_{\text{web}} \cdot (h - h_{\text{flange}}) = 7.275 \text{ m}^2$$

$$I_{\text{eff.support1}} := \frac{1}{12} \cdot b_{\text{eff.support}} \cdot h^3 - \frac{1}{12} \cdot (b_{\text{eff.support}} - b_{\text{web}}) \cdot (h - h_{\text{flange}})^3$$

$$I_{\text{eff.support2}} := (b_{\text{eff.support}} \cdot h) \cdot \left( \frac{h}{2} - \text{COG}_{\text{s.z.up}} \right)^2$$

$$I_{\text{eff.support3}} := - \left( (b_{\text{eff.support}} - b_{\text{web}}) \cdot (h - h_{\text{flange}}) \cdot \left( \frac{h - h_{\text{flange}}}{2} - \text{COG}_{\text{s.z.down}} \right)^2 \right)$$

$$I_{\text{eff.support}} := I_{\text{eff.support1}} + I_{\text{eff.support2}} + I_{\text{eff.support3}} = 1.08 \text{ m}^4$$

$$A_p := 150 \text{ mm}^2 \cdot 15 = (2.25 \cdot 10^3) \text{ mm}^2$$

$$n_{\text{support}} := 10$$

$$A_{p.\text{support}} := A_p \cdot n_{\text{support}} = 22500 \text{ mm}^2$$

$$k := 0.0035$$

$$A_{t.\text{eff}} := A_{\text{eff.support}} + (\eta - 1) \cdot A_{p.\text{support}} = 7.58 \text{ m}^2$$

$$e_{p.\text{support}} := 400 \text{ mm}$$

$$y_{t.\text{eff}} := \frac{(\eta - 1) \cdot A_{p.\text{support}} \cdot e_{p.\text{support}}}{A_{t.\text{eff}}} = 16.103 \text{ mm}$$

$$y_{\text{eff}} := \text{COG}_{\text{s.z.down}} = 0.702 \text{ m}$$

$$I_{t.\text{eff.support}} := I_{\text{eff.support}} + A_{\text{eff.support}} \cdot y_{t.\text{eff}}^2 + (\eta - 1) \cdot A_{p.\text{support}} \cdot (e_{p.\text{support}} - y_{t.\text{eff}})^2 = 1.126 \text{ m}^4$$

## Characteristic combination

$$N_{char.support} := -22374 \text{ kN} \quad M_{char.support} := 12152 \text{ kN}\cdot\text{m}$$

$$\text{Upper edge of cross section} \quad k := COG_{s.z.up} - y_{t,eff} = 0.582 \text{ m}$$

$$\sigma_{c.u.char} := \frac{N_{char.support}}{A_{t,eff}} + \frac{M_{char.support} \cdot (COG_{s.z.up} - y_{t,eff})}{I_{t,eff.support}} = 3.326 \text{ MPa}$$

$$\text{Lower edge of cross section} \quad k := COG_{s.z.down} + y_{t,eff} = 0.718 \text{ m}$$

$$\sigma_{c.l.char} := \frac{N_{char.support}}{A_{t,eff}} + \frac{M_{char.support} \cdot -(COG_{s.z.down} + y_{t,eff})}{I_{t,eff.support}} = -10.698 \text{ MPa}$$

Stress limitation

Compression stress

Tension stress

$$\sigma_{comp} := 0.6 \cdot f_{ck} = 27 \text{ MPa}$$

$$\sigma_{tens} := f_{ctm} = 3.8 \text{ MPa}$$

$$cap := \begin{cases} \text{if } \sigma_{comp} \geq \sigma_{c.l.char} \\ \text{“OK”} \\ \text{else} \\ \text{“!!NOT OK!!”} \end{cases}$$

$$cap := \begin{cases} \text{if } f_{ctm} \geq \sigma_{c.u.char} \\ \text{“OK”} \\ \text{else} \\ \text{“!!NOT OK!!”} \end{cases}$$

## Frequent combination

$$N_{fre.support} := -22717 \text{ kN} \quad M_{fre.support} := 7881 \text{ kN}\cdot\text{m}$$

$$\text{Upper edge of cross section} \quad k := COG_{s.z.up} - y_{t,eff} = 0.582 \text{ m}$$

$$\sigma_{c.u.fre} := \frac{N_{fre.support}}{A_{t,eff}} + \frac{M_{fre.support} \cdot (COG_{s.z.up} - y_{t,eff})}{I_{t,eff.support}} = 1.074 \text{ MPa}$$

$$\text{Lower edge of cross section} \quad k := COG_{s.z.down} + y_{t,eff} = 0.718 \text{ m}$$

$$\sigma_{c.l.fre} := \frac{N_{fre.support}}{A_{t,eff}} + \frac{M_{fre.support} \cdot -(COG_{s.z.down} + y_{t,eff})}{I_{t,eff.support}} = -8.021 \text{ MPa}$$

Stress limitation

Compression stress

Tension stress

$$\sigma_{comp} := 0.45 \cdot f_{ck} = 20.25 \text{ MPa}$$

$$\sigma_{tens} := f_{ctm} = 3.8 \text{ MPa}$$

$$cap := \begin{cases} \text{if } \sigma_{comp} \geq \sigma_{c.l.fre} \\ \text{“OK”} \\ \text{else} \\ \text{“!!NOT OK!!”} \end{cases}$$

$$cap := \begin{cases} \text{if } f_{ctm} \geq \sigma_{c.u.fre} \\ \text{“OK”} \\ \text{else} \\ \text{“!!NOT OK!!”} \end{cases}$$

## Quasi-permanent combination

$$N_{qua.support} := -22984 \text{ kN} \quad M_{qua.support} := 7202 \text{ kN}\cdot\text{m}$$

Upper edge of cross section  $k := COG_{s.z.up} - y_{t.eff} = 0.582 \text{ m}$

$$\sigma_{c.u.qua} := \frac{N_{qua.support}}{A_{t.eff}} + \frac{M_{qua.support} \cdot (COG_{s.z.up} - y_{t.eff})}{I_{t.eff.support}} = 0.688 \text{ MPa}$$

Lower edge of cross section  $k := COG_{s.z.down} + y_{t.eff} = 0.718 \text{ m}$

$$\sigma_{c.l.qua} := \frac{N_{qua.support}}{A_{t.eff}} + \frac{M_{qua.support} \cdot -(COG_{s.z.down} + y_{t.eff})}{I_{t.eff.support}} = -7.623 \text{ MPa}$$

Stress limitation

Compression stress

Tension stress

$$\sigma_{comp} := 0.45 \cdot f_{ck} = 20.25 \text{ MPa}$$

$$\sigma_{tens} := f_{ctm} = 3.8 \text{ MPa}$$

$$cap := \begin{cases} \text{if } \sigma_{comp} \geq \sigma_{c.l.qua} \\ \quad \text{"OK"} \\ \text{else} \\ \quad \text{"!!NOT OK!!"} \end{cases} = \text{"OK"}$$

$$cap := \begin{cases} \text{if } f_{ctm} \geq \sigma_{c.u.qua} \\ \quad \text{"OK"} \\ \text{else} \\ \quad \text{"!!NOT OK!!"} \end{cases} = \text{"OK"}$$

## Middle span

$$A_{eff.span} := b_{eff} \cdot h_{flange} + b_{web} \cdot (h - h_{flange}) = 7.725 \text{ m}^2$$

$$I_{eff.span1} := \frac{1}{12} \cdot b_{eff} \cdot h^3 - \frac{1}{12} \cdot (b_{eff} - b_{web}) \cdot (h - h_{flange})^3$$

$$I_{eff.span2} := (b_{eff} \cdot h) \cdot \left( \frac{h}{2} - COG_{z.up} \right)^2$$

$$I_{eff.span3} := - \left( (b_{eff} - b_{web}) \cdot (h - h_{flange}) \cdot \left( \frac{h - h_{flange}}{2} - COG_{z.down} \right)^2 \right)$$

$$I_{eff.span} := I_{eff.span1} + I_{eff.span2} + I_{eff.span3} = 1.16 \text{ m}^4$$

$$A_p := 150 \text{ mm}^2 \cdot 15 = (2.25 \cdot 10^3) \text{ mm}^2$$

$$n_{span} := 8$$

$$A_{p.span} := A_p \cdot n_{span} = 18000 \text{ mm}^2$$

$$k := 0.0035$$

$$A_{t,eff} := A_{eff.span} + (\eta - 1) \cdot A_{p.span} = 7.969 \text{ m}^2$$

$$e_{p.span} := 575 \text{ mm}$$

$$y_{t,eff} := \frac{(\eta - 1) \cdot A_{p.span} \cdot e_{p.span}}{A_{t,eff}} = 17.615 \text{ mm}$$

$$I_{t,eff.span} := I_{eff.span} + A_{t,eff} \cdot y_{t,eff}^2 + (\eta - 1) \cdot A_{p.span} \cdot (e_{p.span} - y_{t,eff})^2 = 1.239 \text{ m}^4$$

## In the middle span

### Characteristic combination

$$N_{char.span} := -18031 \text{ kN} \quad M_{char.span} := 9866 \text{ kN}\cdot\text{m}$$

$$\text{Upper edge of cross section} \quad k := COG_{z.up} + y_{t.eff} = 0.593 \text{ m}$$

$$\sigma_{c.u.char} := \frac{N_{char.span}}{A_{t.eff}} + \frac{M_{char.span} \cdot -(COG_{z.up} + y_{t.eff})}{I_{t.eff.span}} = -6.982 \text{ MPa}$$

$$\text{Lower edge of cross section} \quad k := COG_{z.down} - y_{t.eff} = 0.707 \text{ m}$$

$$\sigma_{c.l.char} := \frac{N_{char.span}}{A_{t.eff}} + \frac{M_{char.span} \cdot (COG_{z.down} - y_{t.eff})}{I_{t.eff.span}} = 3.371 \text{ MPa}$$

Stress limitation

Compression stress

Tension stress

$$\sigma_{comp} := 0.6 \cdot f_{ck} = 27 \text{ MPa}$$

$$\sigma_{tens} := f_{ctm} = 3.8 \text{ MPa}$$

$$cap := \begin{cases} \text{if } \sigma_{comp} \geq \sigma_{c.u.char} \\ \text{“OK”} \\ \text{else} \\ \text{“!!NOT OK!!”} \end{cases}$$

$$cap := \begin{cases} \text{if } f_{ctm} \geq \sigma_{c.l.char} \\ \text{“OK”} \\ \text{else} \\ \text{“!!NOT OK!!”} \end{cases}$$

## Frequent combination

$$N_{char.fre} := -18672 \text{ kN} \quad M_{char.fre} := 4865 \text{ kN}\cdot\text{m}$$

$$\text{Upper edge of cross section} \quad k := COG_{z.up} + y_{t.eff} = 0.593 \text{ m}$$

$$\sigma_{c.u.fre} := \frac{N_{char.fre}}{A_{t.eff}} + \frac{M_{char.fre} \cdot -(COG_{z.up} + y_{t.eff})}{I_{t.eff.span}} = -4.67 \text{ MPa}$$

$$\text{Lower edge of cross section} \quad k := COG_{z.down} - y_{t.eff} = 0.707 \text{ m}$$

$$\sigma_{c.l.fre} := \frac{N_{char.fre}}{A_{t.eff}} + \frac{M_{char.fre} \cdot (COG_{z.down} - y_{t.eff})}{I_{t.eff.span}} = 0.435 \text{ MPa}$$

Stress limitation

Compression stress

Tension stress

$$\sigma_{comp} := 0.45 \cdot f_{ck} = 20.25 \text{ MPa}$$

$$\sigma_{tens} := f_{ctm} = 3.8 \text{ MPa}$$

$$cap := \begin{cases} \text{if } \sigma_{comp} \geq \sigma_{c.u.fre} \\ \text{“OK”} \\ \text{else} \\ \text{“!!NOT OK!!”} \end{cases}$$

$$cap := \begin{cases} \text{if } f_{ctm} \geq \sigma_{c.l.fre} \\ \text{“OK”} \\ \text{else} \\ \text{“!!NOT OK!!”} \end{cases}$$

## Quasi-permanent combination

$$N_{char.qua} := -18835 \text{ kN}$$

$$M_{char.qua} := 4341 \text{ kN}\cdot\text{m}$$

Upper edge of cross section

$$k := COG_{z.up} + y_{t.eff} = 0.593 \text{ m}$$

$$\sigma_{c.u.qua} := \frac{N_{char.qua}}{A_{t.eff}} + \frac{M_{char.qua} \cdot -(COG_{z.up} + y_{t.eff})}{I_{t.eff.span}} = -4.44 \text{ MPa}$$

Lower edge of cross section

$$k := COG_{z.down} - y_{t.eff} = 0.707 \text{ m}$$

$$\sigma_{c.l.qua} := \frac{N_{char.qua}}{A_{t.eff}} + \frac{M_{char.qua} \cdot (COG_{z.down} - y_{t.eff})}{I_{t.eff.span}} = 0.115 \text{ MPa}$$

Stress limitation

Compression stress

Tension stress

$$\sigma_{comp} := 0.45 \cdot f_{ck} = 20.25 \text{ MPa}$$

$$\sigma_{tens} := f_{ctm} = 3.8 \text{ MPa}$$

$$cap := \begin{cases} \text{if } \sigma_{comp} \geq \sigma_{c.u.qua} \\ \quad \text{“OK”} \\ \text{else} \\ \quad \text{“!!NOT OK!!”} \end{cases} = \text{“OK”}$$

$$cap := \begin{cases} \text{if } f_{ctm} \geq \sigma_{c.l.qua} \\ \quad \text{“OK”} \\ \text{else} \\ \quad \text{“!!NOT OK!!”} \end{cases} = \text{“OK”}$$

## Side span

$$A_{\text{eff.span}} := b_{\text{eff}} \cdot h_{\text{flange}} + b_{\text{web}} \cdot (h - h_{\text{flange}}) = 7.725 \text{ m}^2$$

$$I_{\text{eff.span1}} := \frac{1}{12} \cdot b_{\text{eff}} \cdot h^3 - \frac{1}{12} \cdot (b_{\text{eff}} - b_{\text{web}}) \cdot (h - h_{\text{flange}})^3$$

$$I_{\text{eff.span2}} := (b_{\text{eff}} \cdot h) \cdot \left( \frac{h}{2} - \text{COG}_{z,\text{up}} \right)^2$$

$$I_{\text{eff.span3}} := - \left( (b_{\text{eff}} - b_{\text{web}}) \cdot (h - h_{\text{flange}}) \cdot \left( \frac{h - h_{\text{flange}}}{2} - \text{COG}_{z,\text{down}} \right)^2 \right)$$

$$I_{\text{eff.span}} := I_{\text{eff.span1}} + I_{\text{eff.span2}} + I_{\text{eff.span3}} = 1.16 \text{ m}^4$$

$$A_p := 150 \text{ mm}^2 \cdot 15 = (2.25 \cdot 10^3) \text{ mm}^2$$

$$n_{\text{span}} := 6$$

$$A_{p.\text{span}} := A_p \cdot n_{\text{span}} = 13500 \text{ mm}^2$$

$$k := 0.0035$$

$$A_{t.\text{eff}} := A_{\text{eff.span}} + (\eta - 1) \cdot A_{p.\text{span}} = 7.908 \text{ m}^2$$

$$e_{p.\text{span}} := 575 \text{ mm}$$

$$y_{t.\text{eff}} := \frac{(\eta - 1) \cdot A_{p.\text{span}} \cdot e_{p.\text{span}}}{A_{t.\text{eff}}} = 13.314 \text{ mm}$$

$$I_{t.\text{eff.span}} := I_{\text{eff.span}} + A_{t.\text{eff}} \cdot y_{t.\text{eff}}^2 + (\eta - 1) \cdot A_{p.\text{span}} \cdot (e_{p.\text{span}} - y_{t.\text{eff}})^2 = 1.22 \text{ m}^4$$



**Characteristic combination**

$$N_{char.span} := -12978 \text{ kN} \quad M_{char.span} := 8046 \text{ kN}\cdot\text{m}$$

$$\text{Upper edge of cross section} \quad k := COG_{z.up} + y_{t.eff} = 0.588 \text{ m}$$

$$\sigma_{c.u.char} := \frac{N_{char.span}}{A_{t.eff}} + \frac{M_{char.span} \cdot -(COG_{z.up} + y_{t.eff})}{I_{t.eff.span}} = -5.522 \text{ MPa}$$

$$\text{Lower edge of cross section} \quad k := COG_{z.down} - y_{t.eff} = 0.712 \text{ m}$$

$$\sigma_{c.l.char} := \frac{N_{char.span}}{A_{t.eff}} + \frac{M_{char.span} \cdot (COG_{z.down} - y_{t.eff})}{I_{t.eff.span}} = 3.054 \text{ MPa}$$

Stress limitation

Compression stress

Tension stress

$$\sigma_{comp} := 0.6 \cdot f_{ck} = 27 \text{ MPa}$$

$$\sigma_{tens} := f_{ctm} = 3.8 \text{ MPa}$$

$$cap := \begin{cases} \text{if } \sigma_{comp} \geq \sigma_{c.u.char} \\ \quad \text{“OK”} \\ \text{else} \\ \quad \text{“!!NOT OK!!”} \end{cases}$$

$$cap := \begin{cases} \text{if } f_{ctm} \geq \sigma_{c.l.char} \\ \quad \text{“OK”} \\ \text{else} \\ \quad \text{“!!NOT OK!!”} \end{cases}$$

**Frequent combination**

$$N_{char.fre} := -13103 \text{ kN} \quad M_{char.fre} := 4729 \text{ kN}\cdot\text{m}$$

$$\text{Upper edge of cross section} \quad k := COG_{z.up} + y_{t.eff} = 0.588 \text{ m}$$

$$\sigma_{c.u.fre} := \frac{N_{char.fre}}{A_{t.eff}} + \frac{M_{char.fre} \cdot -(COG_{z.up} + y_{t.eff})}{I_{t.eff.span}} = -3.938 \text{ MPa}$$

$$\text{Lower edge of cross section} \quad k := COG_{z.down} - y_{t.eff} = 0.712 \text{ m}$$

$$\sigma_{c.l.fre} := \frac{N_{char.fre}}{A_{t.eff}} + \frac{M_{char.fre} \cdot (COG_{z.down} - y_{t.eff})}{I_{t.eff.span}} = 1.103 \text{ MPa}$$

Stress limitation

Compression stress

Tension stress

$$\sigma_{comp} := 0.45 \cdot f_{ck} = 20.25 \text{ MPa}$$

$$\sigma_{tens} := f_{ctm} = 3.8 \text{ MPa}$$

$$cap := \begin{cases} \text{if } \sigma_{comp} \geq \sigma_{c.u.fre} \\ \quad \text{“OK”} \\ \text{else} \\ \quad \text{“!!NOT OK!!”} \end{cases}$$

$$cap := \begin{cases} \text{if } f_{ctm} \geq \sigma_{c.l.fre} \\ \quad \text{“OK”} \\ \text{else} \\ \quad \text{“!!NOT OK!!”} \end{cases}$$

## Quasi-permanent combination

$$N_{char.qua} := -12936 \text{ kN}$$

$$M_{char.qua} := 3604 \text{ kN}\cdot\text{m}$$

Upper edge of cross section

$$k := COG_{z.up} + y_{t.eff} = 0.588 \text{ m}$$

$$\sigma_{c.u.qua} := \frac{N_{char.qua}}{A_{t.eff}} + \frac{M_{char.qua} \cdot -(COG_{z.up} + y_{t.eff})}{I_{t.eff.span}} = -3.374 \text{ MPa}$$

Lower edge of cross section

$$k := COG_{z.down} - y_{t.eff} = 0.712 \text{ m}$$

$$\sigma_{c.l.qua} := \frac{N_{char.qua}}{A_{t.eff}} + \frac{M_{char.qua} \cdot (COG_{z.down} - y_{t.eff})}{I_{t.eff.span}} = 0.467 \text{ MPa}$$

Stress limitation

Compression stress

Tension stress

$$\sigma_{comp} := 0.45 \cdot f_{ck} = 20.25 \text{ MPa}$$

$$\sigma_{tens} := f_{ctm} = 3.8 \text{ MPa}$$

$$cap := \begin{cases} \text{if } \sigma_{comp} \geq \sigma_{c.u.qua} \\ \quad \text{“OK”} \\ \text{else} \\ \quad \text{“!!NOT OK!!”} \end{cases} = \text{“OK”}$$

$$cap := \begin{cases} \text{if } f_{ctm} \geq \sigma_{c.l.qua} \\ \quad \text{“OK”} \\ \text{else} \\ \quad \text{“!!NOT OK!!”} \end{cases} = \text{“OK”}$$

## Transverse direction

$$b := 1000 \text{ mm} \quad h := 350 \text{ mm}$$

Assume 2 cables 6802 for 1 m and 15% loss

$$n_{tra} := 2$$

$$A_{cable} := 300 \text{ mm}^2$$

$$A_{p.tra} := n_{tra} \cdot A_{cable} = 600 \text{ mm}^2$$

$$P_{0.max} := \sigma_{p.max} \cdot A_{p.tra} \cdot 0.8 = 691.2 \text{ kN}$$

$$A_t := b \cdot h + \left( \frac{E_p}{E_c} - 1 \right) \cdot A_{p.tra} = 0.353 \text{ m}^2$$

$$e := 75 \text{ mm}$$

$$\eta := \frac{E_p}{E_{cm}} = 14.563$$

$$y_t := \frac{(\eta - 1) \cdot A_{p.tra} \cdot e}{A_t} = 1.731 \text{ mm}$$

$$I_t := \frac{b \cdot h^3}{12} + b \cdot h \cdot y_t^2 + (\eta - 1) \cdot A_{p.tra} \cdot (e - y_t)^2 = (3.618 \cdot 10^9) \text{ mm}^4$$

Moment from prestressing

$$M_{pr} := -P_{0.max} \cdot (e - y_t) = -50.644 \text{ kN} \cdot \text{m}$$

$$M_g := 13.4 \text{ kN} \cdot \text{m}$$

self-weight of the slab

Self-weight + prestressing

$$M_t := -P_{0.max} \cdot (e - y_t) + M_g = -37.244 \text{ kN} \cdot \text{m}$$

$$P_0 := P_{0.max}$$

## Stress

Self-weight + prestressing

Upper edge of cross section

Lower edge of cross section

$$\sigma_{c,u} := \frac{-P_0}{A_t} + \frac{M_t \cdot \left(\frac{h}{2} - y_t\right)}{I_t} = -3.744 \text{ MPa}$$

$$\sigma_{c,l} := \frac{-P_0}{A_t} + \frac{M_t \cdot \left(-\frac{h}{2} - y_t\right)}{I_t} = -0.141 \text{ MPa}$$

Stress limitation

Compression stress

Tension stress

$$\sigma_{comp} := 0.6 \cdot f_{ck} = 27 \text{ MPa}$$

$$\sigma_{tens} := f_{ctm} = 3.8 \text{ MPa}$$

$$cap := \begin{cases} \text{if } \sigma_{comp} \geq \sigma_{c,u} \\ \quad \text{"OK"} \\ \text{else} \\ \quad \text{"!!NOT OK!!"} \end{cases} = \text{"OK"}$$

$$cap := \begin{cases} \text{if } f_{ctm} \geq \sigma_{c,l} \\ \quad \text{"OK"} \\ \text{else} \\ \quad \text{"!!NOT OK!!"} \end{cases} = \text{"OK"}$$

**Stress****Characteristic combination**

$$M_{Ed} := 120.8 \text{ kN}\cdot\text{m}$$

$$M_t := -P_0 \cdot (e - y_t) + M_{Ed} = 70.156 \text{ kN}\cdot\text{m}$$

Upper edge of cross section

Lower edge of cross section

$$\sigma_{c,u} := \frac{-P_0}{A_t} + \frac{M_t \cdot \left(\frac{h}{2} - y_t\right)}{I_t} = 1.4 \text{ MPa}$$

$$\sigma_{c,l} := \frac{-P_0}{A_t} + \frac{M_t \cdot \left(-\frac{h}{2} - y_t\right)}{I_t} = -5.387 \text{ MPa}$$

Stress limitation

Compression stress

Tension stress

$$\sigma_{comp} := 0.6 \cdot f_{ck} = 27 \text{ MPa}$$

$$\sigma_{tens} := f_{ctm} = 3.8 \text{ MPa}$$

$$cap := \begin{cases} \text{if } \sigma_{comp} \geq \sigma_{c,l} \\ \text{“OK”} \\ \text{else} \\ \text{“!!NOT OK!!”} \end{cases} = \text{“OK”}$$

$$cap := \begin{cases} \text{if } f_{ctm} \geq \sigma_{c,u} \\ \text{“OK”} \\ \text{else} \\ \text{“!!NOT OK!!”} \end{cases} = \text{“OK”}$$

**Frequent combination**

$$M_{Ed} := 88.6 \text{ kN}\cdot\text{m}$$

$$M_t := -P_0 \cdot (e - y_t) + M_{Ed} = 37.956 \text{ kN}\cdot\text{m}$$

Upper edge of cross section

Lower edge of cross section

$$\sigma_{c,u} := \frac{-P_0}{A_t} + \frac{M_t \cdot \left(\frac{h}{2} - y_t\right)}{I_t} = -0.142 \text{ MPa}$$

$$\sigma_{c,l} := \frac{-P_0}{A_t} + \frac{M_t \cdot \left(-\frac{h}{2} - y_t\right)}{I_t} = -3.814 \text{ MPa}$$

Stress limitation

Compression stress

Tension stress

$$\sigma_{comp} := 0.45 \cdot f_{ck} = 20.25 \text{ MPa}$$

$$\sigma_{tens} := f_{ctm} = 3.8 \text{ MPa}$$

$$cap := \begin{cases} \text{if } \sigma_{comp} \geq \sigma_{c,l} \\ \text{“OK”} \\ \text{else} \\ \text{“!!NOT OK!!”} \end{cases} = \text{“OK”}$$

$$cap := \begin{cases} \text{if } f_{ctm} \geq \sigma_{c,u} \\ \text{“OK”} \\ \text{else} \\ \text{“!!NOT OK!!”} \end{cases} = \text{“OK”}$$

### Quasi-permanent combination

$$M_{Ed} := 67.1 \text{ kN}\cdot\text{m}$$

$$M_t := -P_0 \cdot (e - y_t) + M_{Ed} = 16.456 \text{ kN}\cdot\text{m}$$

Upper edge of cross section

$$\sigma_c := \frac{-P_0}{A_t} + \frac{M_t \cdot \left(\frac{h}{2} - y_t\right)}{I_t} = -1.172 \text{ MPa}$$

Lower edge of cross section

$$\sigma_c := \frac{-P_0}{A_t} + \frac{M_t \cdot \left(-\frac{h}{2} - y_t\right)}{I_t} = -2.764 \text{ MPa}$$

Stress limitation

Compression stress

There is no value to compare, but the whole cross section is in compression

Tension stress

the cross section in compression

## Crack control

according EC 1992 7.3

### Reinforced members

XD1 top surface       $0.3 k_c$       Quasi-permanent load combination

XC3 bottom surface       $0.3 k_c$       Quasi-permanent load combination

### Prestressed members with bonded tendons

XD1 top surface       $0.2 k_c$       Frequent load combination

XC3 bottom surface       $0.2 k_c$       Frequent load combination

Decompression      Quasi-permanent load combination

$$c_{nom.t} := 90 \text{ mm} \quad c_{min.dur.t} := 60 \text{ mm} \quad k_{c.t} := \frac{c_{nom.t}}{c_{min.dur.t}} = 1.5 \quad \text{top surface}$$

$$c_{nom.b} := 90 \text{ mm} \quad c_{min.dur.b} := 45 \text{ mm} \quad k_{c.b} := \frac{c_{nom.b}}{c_{min.dur.b}} = 2 \quad \text{bottom surface}$$

Maximal value for       $k_c := 1.3$

NA.7.3.1

### Reinforced members

XD1 top surface       $0.3 k_c = 0.39$  [mm]      Quasi-permanent load combination

XC3 bottom surface       $0.3 k_c = 0.39$  [mm]      Quasi-permanent load combination

### Prestressed members with bonded tendons

XD1 top surface       $0.2 k_c = 0.26$  [mm]      Frequent load combination

Decompression      Quasi-permanent load combination

XC3 bottom surface       $0.2 k_c = 0.26$  [mm]      Frequent load combination

## Quasi-permanent load combination

### Over support

Decompression

$$\sigma_{c.u.qua} := 0.688 \text{ MPa}$$

$$h := 1300 \text{ mm} = 1.3 \text{ m}$$

$$\sigma_{c.l.qua} := -7.623 \text{ MPa}$$

Height of compression zone

$$\alpha d := \frac{h \cdot \sigma_{c.l.qua}}{(\sigma_{c.l.qua} - \sigma_{c.u.qua})} = 1.192 \text{ m}$$

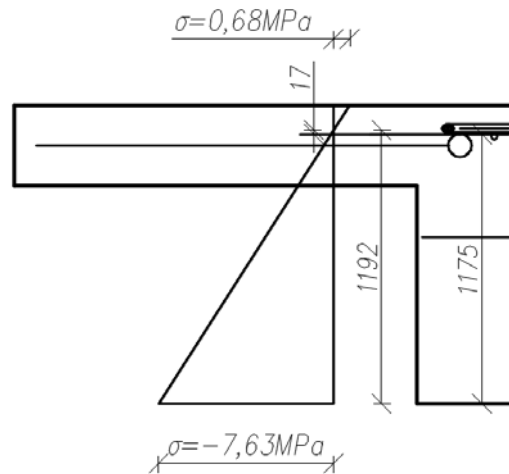

The prestressing steel lays in the compression zone 17 mm . The minimum distance in compression zone is  $\Delta c_{dev} := 10 \text{ mm}$



## Frequent combination

### Side span

$$N_{fre.side} := -13103 \text{ kN} \quad M_{fre.side} := 4729 \text{ kN}\cdot\text{m}$$

Upper edge of cross section

$$\sigma_{c.u.fre} := -3.938 \text{ MPa} \quad d := 1.15 \text{ m}$$

$$\text{Lower edge of cross section } A_s := 6 \cdot 2250 \text{ mm}^2 + 25 \cdot \pi \cdot (12.5 \text{ mm})^2 = 25771.846 \text{ mm}^2$$

$$\sigma_{c.l.fre} := 1.103 \text{ MPa}$$

$$ad := \frac{h \cdot \sigma_{c.u.fre}}{(\sigma_{c.u.fre} - \sigma_{c.l.fre})} = 1.016 \text{ m}$$

### Cracked cross section

$$\eta := \frac{E_s}{E_c} = 5.556 \quad \rho := \frac{A_s}{b_{web} \cdot d} = 0.004 \quad d := 1150 \text{ mm} \quad b_{web} = 5 \text{ m}$$

$$a := \frac{-M_{fre.side}}{N_{fre.side}} = 0.361 \text{ m} \quad e := 575 \text{ mm}$$

Axial force

$$A(\alpha) := \frac{-N_{fre.side}}{b_{web} \cdot d \cdot \left( \frac{1}{2} \cdot \alpha - \eta \cdot \rho \cdot \frac{1-\alpha}{\alpha} \right)}$$

Moment

$$M(\alpha) := \frac{-N_{fre.side}}{\left( \frac{d}{e+a} \cdot \left( \frac{1}{2} \cdot \alpha \cdot \left( 1 - \frac{\alpha}{3} \right) \right) \right) \cdot b_{web} \cdot d}$$

$$\alpha := 0.6, 0.65 \dots 7$$

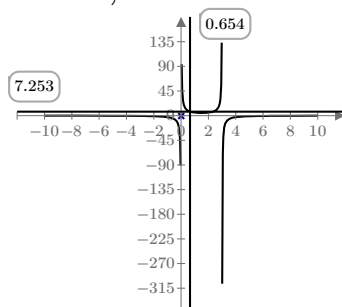

$A(\alpha)$  (MPa)

$M(\alpha)$  (MPa)

$\alpha$

$$\sigma := 7.25 \text{ MPa}$$

$$\alpha := 0.65$$

$$\varepsilon_{c.fre} := \frac{\sigma}{E_{cm}} = 5.415 \cdot 10^{-4}$$

$$\Delta\varepsilon_p := \varepsilon_{c.fre} \cdot \frac{1-\alpha}{\alpha} = 2.916 \cdot 10^{-4}$$

$$\Delta\sigma_{p.fre} := (\Delta\varepsilon_p) \cdot E_p = 56.853 \text{ MPa}$$

$$A_s := \pi \cdot (12.5 \text{ mm})^2 = 490.874 \text{ mm}^2$$

$$k_1 := 1.6$$

$$\xi := 0.3$$

Table 6.2

$$k_2 := 0.5$$

$$\phi_s := 25 \text{ mm}$$

$$k_3 := 3.4$$

$$A_p := 150 \text{ mm}^2$$

$$k_4 := 0.425$$

$$\phi_p := 1.6 \sqrt{A_p} = 19.596 \text{ mm}$$

$$\phi_{ef} := \frac{15 \cdot 6 \cdot \phi_p^2 + 25 \cdot \phi_s^2}{15 \cdot 6 \cdot \phi_p + 25 \cdot \phi_s} = 21.01 \text{ mm}$$

$$\phi := \phi_{ef}$$

$$c := 100 \text{ mm}$$

$$\xi_1 := \sqrt{\xi \cdot \frac{\phi_s}{\phi_p}} = 0.619$$

$$h := 1.3 \text{ m}$$

$$A_p := 2250 \cdot 6 \cdot \text{mm}^2$$

$$x := h - \alpha d = 0.284 \text{ m}$$

$$h_{c.ef} := \min\left(\frac{h}{2}, 2.5 \cdot (h - d), \frac{h - x}{3}\right) = 0.339 \text{ m}$$

$$A_{c.ef} := h_{c.ef} \cdot b_{web} = 1.693 \text{ m}^2$$

$$\rho_{p.ef} := \frac{25 A_s + \xi_1^2 \cdot A_p}{A_{c.ef}} = 0.01$$

$$s_{r,max} := k_3 \cdot c + \frac{k_1 \cdot k_2 \cdot k_4 \cdot \phi}{\rho_{p,eff}} = 1.033 \text{ m}$$

$$k_t := 0.4$$

$$\alpha_e := \frac{E_s}{E_{cm}} = 14.937$$

$$\Delta\sigma_{p,fre} = 56.853 \text{ MPa}$$

$$\varepsilon_{sm} - \varepsilon_{cm} \quad \Delta\varepsilon_1 := \frac{\Delta\sigma_{p,fre} - k_t \cdot \frac{f_{ctm}}{\rho_{p,eff}} \cdot (1 + \alpha_e \cdot \rho_{p,eff})}{E_s} = -5.669 \cdot 10^{-4}$$

$$\Delta\varepsilon_2 := 0.6 \cdot \frac{\Delta\sigma_{p,fre}}{E_s} = 1.706 \cdot 10^{-4}$$

$$\Delta\varepsilon := \max(\Delta\varepsilon_1, \Delta\varepsilon_2) = 1.706 \cdot 10^{-4}$$

Crack width

$$w_k := s_{r,max} \cdot (\Delta\varepsilon) = 0.176 \text{ mm}$$

**Over support**

$$N_{fre.sup} := -22717 \text{ kN}$$

$$M_{fre.sup} := 7881 \text{ kN}\cdot\text{m}$$

Upper edge of cross section

$$\sigma_{c.u.fre} := 1.074 \text{ MPa}$$

$$d := 1.125 \text{ m}$$

Lower edge of cross section  $A_s := 10 \cdot 2250 \text{ mm}^2 + 33 \cdot \pi \cdot (12.5 \text{ mm})^2 = 38698.837 \text{ mm}^2$ 

$$\sigma_{c.l.fre} := -8.021 \text{ MPa}$$

$$\alpha d := \frac{h \cdot \sigma_{c.l.fre}}{(-\sigma_{c.u.fre} + \sigma_{c.l.fre})} = 1.146 \text{ m}$$

**Cracked cross section**

$$\eta := \frac{E_s}{E_c} = 5.556 \quad \rho := \frac{A_s}{b_{support} \cdot d} = 0.004 \quad d := 1125 \text{ mm}$$

$$b_{support} := 8.5 \text{ m}$$

$$a := \frac{-M_{fre.sup}}{N_{fre.sup}} = 0.347 \text{ m} \quad e := 400 \text{ mm}$$

Axial force

$$A(\alpha) := \frac{-N_{fre.side}}{b_{support} \cdot d \cdot \left( \frac{1}{2} \cdot \alpha - \eta \cdot \rho \cdot \frac{1-\alpha}{\alpha} \right)}$$

Moment

$$M(\alpha) := \frac{-N_{fre.side}}{\left( \frac{d}{e+a} \cdot \left( \frac{1}{2} \cdot \alpha \cdot \left( 1 - \frac{\alpha}{3} \right) \right) \right)} \cdot b_{support} \cdot d$$

$$\alpha := 0.93, 0.95 \dots 1.1$$

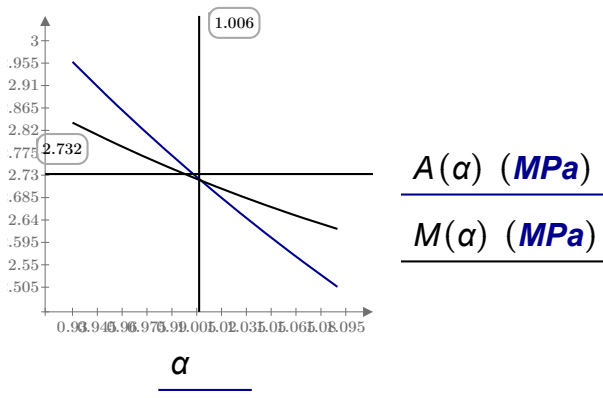

$$\sigma := 2.7 \text{ MPa}$$

$$\alpha := 0.99$$

$$\varepsilon_{c.fre} := \frac{\sigma}{E_{cm}} = 2.016 \cdot 10^{-4}$$

$$\Delta\varepsilon_p := \varepsilon_{c.fre} \cdot \frac{1-\alpha}{\alpha} = 2.037 \cdot 10^{-6}$$

$$\Delta\sigma_{p.fre} := (\Delta\varepsilon_p) \cdot E_p = 0.397 \text{ MPa}$$

$$A_s := \pi \cdot (12.5 \text{ mm})^2 = 490.874 \text{ mm}^2$$

$$k_1 := 1.6$$

$$\xi := 0.3$$

**Table 6.2**

$$k_2 := 0.5$$

$$\phi_s := 25 \text{ mm}$$

$$k_3 := 3.4$$

$$A_p := 150 \text{ mm}^2$$

$$k_4 := 0.425$$

$$\phi_p := 1.6 \sqrt{A_p} = 19.596 \text{ mm}$$

$$\phi_{ef} := \frac{15 \cdot 10 \cdot \phi_p^2 + 33 \cdot \phi_s^2}{15 \cdot 10 \cdot \phi_p + 33 \cdot \phi_s} = 20.78 \text{ mm}$$

$$\phi := \phi_{ef}$$

$$c := 125 \text{ mm}$$

$$\xi_1 := \sqrt{\xi \cdot \frac{\phi_s}{\phi_p}} = 0.619$$

$$h := 1.3 \text{ m}$$

$$A_p := 2250 \cdot 10 \cdot \text{mm}^2$$

$$x := h - ad = 0.154 \text{ m}$$

$$h_{c.ef} := \min\left(\frac{h}{2}, 2.5 \cdot (h - d), \frac{h - x}{3}\right) = 0.382 \text{ m}$$

$$A_{c.ef} := h_{c.ef} \cdot b_{support} = 3.248 \text{ m}^2$$

$$\rho_{p.ef} := \frac{A_s + \xi_1^2 \cdot A_p}{A_{c.ef}} = 0.003$$

$$s_{r,max} := k_3 \cdot c + \frac{k_1 \cdot k_2 \cdot k_4 \cdot \phi}{\rho_{p,eff}} = 2.946 \text{ m}$$

$$k_t := 0.4$$

$$\alpha_e := \frac{E_s}{E_{cm}} = 14.937$$

$$\Delta\sigma_{p,fre} = 0.397 \text{ MPa}$$

$$\varepsilon_{sm} - \varepsilon_{cm} \quad \Delta\varepsilon_1 := \frac{\Delta\sigma_{p,fre} - k_t \cdot \frac{f_{ctm}}{\rho_{p,eff}} \cdot (1 + \alpha_e \cdot \rho_{p,eff})}{E_s} = -0.003$$

$$\Delta\varepsilon_2 := 0.6 \cdot \frac{\Delta\sigma_{p,fre}}{E_s} = 1.192 \cdot 10^{-6}$$

$$\Delta\varepsilon := \max(\Delta\varepsilon_1, \Delta\varepsilon_2) = 1.192 \cdot 10^{-6}$$

Crack width

$$w_k := s_{r,max} \cdot (\Delta\varepsilon) = 0.004 \text{ mm}$$

### Stress in tensile reinforcement - over support

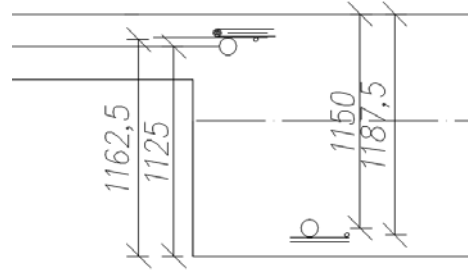

$$E_c = 36000 \text{ MPa} \quad A_c := 5 \text{ m} \cdot 1.3 \text{ m} = 6.5 \text{ m}^2$$

$$E_s = 200000 \text{ MPa} \quad A_s := 33 \cdot \pi \cdot \left( \frac{25 \text{ mm}}{2} \right)^2 = 0.016 \text{ m}^2 \quad n_s := \frac{E_s}{E_c} = 5.556 \quad d_s := 1163 \text{ mm}$$

$$E_p = 195000 \text{ MPa} \quad A_p := 10 \cdot 2250 \text{ mm}^2 = 0.023 \text{ m}^2 \quad n_p := \frac{E_p}{E_c} = 5.417 \quad d_p := 1125 \text{ mm}$$

$$b := 5 \text{ m} \quad h = 1.3 \text{ m}$$

$$\alpha d := \frac{A_c \cdot 0.5 \cdot h + n_s \cdot A_s \cdot d_s + n_p \cdot A_p \cdot d_p}{A_c + n_s \cdot A_s + n_p \cdot A_p} = 0.666 \text{ m}$$

$$\alpha := \frac{\alpha d}{d} = 0.592$$

$$I_c := \frac{b \cdot h^3}{12} + b \cdot h \cdot \left( \alpha d - \frac{h}{2} \right)^2 = 0.917 \text{ m}^4$$

$$I_s := A_s \cdot (d_s - \alpha d)^2 = 0.004 \text{ m}^4$$

$$I_p := A_p \cdot (d_p - \alpha d)^2 = 0.005 \text{ m}^4$$

$$EI := E_c \cdot I_c + E_s \cdot I_s + E_p \cdot I_p = (3.474 \cdot 10^{10}) \frac{\text{kg} \cdot \text{m}^3}{\text{s}^2}$$

$$\sigma_{s.support} := E_s \cdot \frac{(M_{char.support} \cdot (1 - \alpha) \cdot d_s)}{EI} = 33.233 \text{ MPa}$$

$$\sigma_{p.support} := E_p \cdot \frac{(M_{char.support} \cdot (1 - \alpha) \cdot d_p)}{EI} = 31.343 \text{ MPa}$$

### Stress in tensile reinforcement - side span

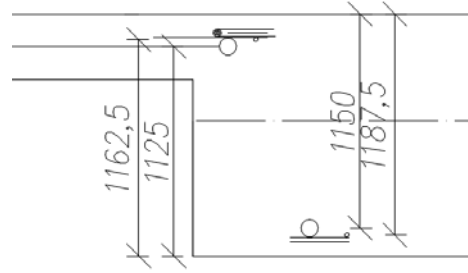

$$E_c = 36000 \text{ MPa} \quad A_c := 5 \text{ m} \cdot 1.3 \text{ m} = 6.5 \text{ m}^2$$

$$E_s = 200000 \text{ MPa} \quad A_s := 25 \cdot \pi \cdot \left( \frac{25 \text{ mm}}{2} \right)^2 = 0.012 \text{ m}^2 \quad n_s := \frac{E_s}{E_c} = 5.556 \quad d_s := 1187 \text{ mm}$$

$$E_p = 195000 \text{ MPa} \quad A_p := 6 \cdot 2250 \text{ mm}^2 = 0.014 \text{ m}^2 \quad n_p := \frac{E_p}{E_c} = 5.417 \quad d_p := 1150 \text{ mm}$$

$$b := 5 \text{ m} \quad h = 1.3 \text{ m}$$

$$\alpha d := \frac{A_c \cdot 0.5 \cdot h + n_s \cdot A_s \cdot d_s + n_p \cdot A_p \cdot d_p}{A_c + n_s \cdot A_s + n_p \cdot A_p} = 0.661 \text{ m}$$

$$\alpha := \frac{\alpha d}{d} = 0.588$$

$$I_c := \frac{b \cdot h^3}{12} + b \cdot h \cdot \left( \alpha d - \frac{h}{2} \right)^2 = 0.916 \text{ m}^4$$

$$I_s := A_s \cdot (d_s - \alpha d)^2 = 0.003 \text{ m}^4$$

$$I_p := A_p \cdot (d_p - \alpha d)^2 = 0.003 \text{ m}^4$$

$$EI := E_c \cdot I_c + E_s \cdot I_s + E_p \cdot I_p = (3.429 \cdot 10^{10}) \frac{\text{kg} \cdot \text{m}^3}{\text{s}^2}$$

$$\sigma_{s.side} := E_s \cdot \frac{(M_{char.span} \cdot (1 - \alpha) \cdot d_s)}{EI} = 22.973 \text{ MPa}$$

$$\sigma_{p.side} := E_p \cdot \frac{(M_{char.span} \cdot (1 - \alpha) \cdot d_p)}{EI} = 21.701 \text{ MPa}$$



Stress in prestressing tendons  
Losses min value from NovaFrame

$$\Delta\sigma_{losses} := 17\%$$

$$\sigma_{p.max} := 0.9 \cdot f_{p.0.1k} = 1440 \text{ MPa}$$

$$\sigma_{p.after.losses} := \sigma_{p.max} \cdot (1 - \Delta\sigma_{losses}) = 1195.2 \text{ MPa}$$

Over support

$$\sigma_{p.support.ean} := \sigma_{p.after.losses} + \sigma_{p.support} = 1226.543 \text{ MPa}$$

In side span

$$\sigma_{p.side.mean} := \sigma_{p.after.losses} + \sigma_{p.side} = 1216.901 \text{ MPa}$$

$$\sigma_{SLS.max} := 1395 \text{ MPa}$$

Transverse direction - assume min losses 10 %

$$\Delta\sigma_{losses} := 10\%$$

$$\sigma_{p.after.losses} := \sigma_{p.max} \cdot (1 - \Delta\sigma_{losses}) = 1296 \text{ MPa}$$