



**NTNU – Trondheim**  
Norwegian University of  
Science and Technology

# A proposal for a RAMS engineering process for blowout preventers

**Anna Magdalena Godziuk**

Reliability, Availability, Maintainability and Safety (RAMS)

Submission date: June 2015

Supervisor: Mary Ann Lundteigen, IPK

Co-supervisor: Geir-Ove Strand, IPK

Professor Jerzy Ejsmont, Gdansk University of Technology

Norwegian University of Science and Technology

Department of Production and Quality Engineering



**RAMS**  
Reliability, Availability,  
Maintainability, and Safety

A proposal for a RAMS engineering  
process for blowout preventers

Anna Magdalena Godziuk

June 2015

MASTER THESIS Department of Production and  
Quality Engineering  
Norwegian University of Science and Technology

Supervisor: Mary Ann Lundteigen, IPK

Co-supervisor: Geir-Ove Strand, IPK  
Professor Jerzy Ejsmont, Gdansk University of Technology



## **Preface**

This Master Thesis work has been carried out at Department of Production and Quality at the Norwegian University of Science and Technology, NTNU, during the spring semester 2015. This thesis is final step towards my M.Sc. degree, where my specialization lies within the reliability engineering and mechanical engineering.

Before beginning of my thesis I had a limited knowledge of blowout preventer system. The gathering of data and literature on reliability, availability, maintainability and safety requirements for BOPs and comparing results have been challenging aspects of this thesis.

I would like to express my deepest gratitude to my supervisor Professor Mary Ann Lundteigen at NTNU for her valuable help and guidance during the semester. Also, I would like to thank Geir-Ove Strand for sharing knowledge and experience regarding BOP system operational activities.

I would like to thank all my friends, who motivated me during this semester. Special thanks to my dear friend, Katarzyna Paulina Mocek, for all her support and help.

Trondheim, 10th June 2015

Anna Godziuk



## Summary

A blowout preventer is a safety critical system used during drilling operations. BOP is system of valves to seal, control and monitor oil and gas in a well. The BOP system is of great importance, since it prevents environmental pollution and loss of human life and health. Thus, BOP system should fulfil high reliable and safety requirements.

The requirements for BOP reliability and safety features can be found mostly in Norwegian and American regulations. The thesis is an attempt to organise and compare regulations and standards, which are world recognisable and commonly used for offshore oil and gas drilling. Also, researches of BOP failures, reliability data and data from testing BOP are important sources of BOP system reliability and safety. To categorise and order regulations, standard and researches in one comprehensive report for BOP system, RAMS engineering model is used.

RAMS is an abbreviation for reliability, availability, maintainability and safety. RAMS oriented life cycle model focus on product's features and characteristics, which fulfil RAMS requirements. RAMS engineering model consists of 8 phases. Each phase is a phase of product life-cycle with taking into account RAMS activities.

The attempt to create RAMS engineering model for BOP system is motivated by need for improvement the BOP's reliability and safety. In view of recent incidents, for example Deepwater Horizon accident in the Gulf of Mexico, the BOP's technology should be developed.





# Contents

- Preface ..... I
- Summary ..... III
- List of figures ..... VII
- List of tables ..... VIII
- Abbreviations ..... IX
- Introduction ..... 1
  - 1.1 Background ..... 1
  - 1.2 Objectives ..... 2
  - 1.3 Scope and limitations ..... 2
  - 1.4 Structure of report ..... 2
- Offshore drilling ..... 4
  - 2.1 Drilling operation ..... 4
  - 2.2 Well integrity ..... 6
  - 2.3 Main phases of drilling operation ..... 6
- RAMS management concepts ..... 9
  - 3.1 RAMS engineering ..... 9
  - 3.2 Concepts of product life-cycle ..... 10
  - 3.3 RAMS engineering model ..... 13
    - 3.3.1 Phase 1 ..... 13
    - 3.3.2 Phase 2 ..... 14
    - 3.3.3 Phase 3 ..... 14
    - 3.3.4 Phase 4 ..... 16
    - 3.3.5 Phase 5 ..... 17

3.3.6	Phase 6.....	17
3.3.7	Phase 7.....	18
3.3.8	Phase 8.....	18
Blowout preventer .....		19
4.1	BOP function.....	19
4.2	Main system elements of BOP system .....	20
4.3	BOP failures and consequences .....	24
4.3.1	Hazards related to offshore drilling.....	24
4.3.2	Availability of data sources on failures and accidents .....	25
4.3.3	BOP failures.....	26
4.3.4	Major accidents .....	27
Proposal of RAMS Engineering model for BOP .....		31
5.1	Phase 1 .....	31
5.2	Phase 2.....	32
5.3	Phase 3.....	35
5.4	Phase 4 and phase 5.....	38
5.5	Phase 6.....	40
5.6	Phase 7.....	42
5.7	Phase 8.....	44
Conclusion .....		45
6.1	Summary and conclusions .....	45
6.2	Recommendations and areas for further research .....	46

## List of figures

Figure 2.1 Types of rigs used in drilling operation (National Commission on the BP Deepwater Horizon Oil Spill and Offshore Drilling, 2011) <b>Błąd! Nie zdefiniowano zakładek.</b>	
Figure 2.2 Drilling operation (National Commission on the BP Deepwater Horizon Oil Spill and Offshore Drilling, 2011).....	5
Figure 2.3 Early drilling phases (National Commission on the BP Deepwater Horizon Oil Spill and Offshore Drilling, 2011) .....	7
Figure 2.4 Perforating the production casing (National Commission on the BP Deepwater Horizon Oil Spill and Offshore Drilling, 2011) .....	8
Figure 3.1 RAMS oriented life-cycle model (Murthy, et al., 2008) .....	13
Figure 3.2 Hierarchy of functions, requirements and solutions (Murthy, et al., 2008).....	15
Figure 4.1 Diagram and photograph of BOP system on Deepwater Horizon (BP, 2010).....	19
Figure 4.2 Variable Bore Ram (Group, 2011) .....	20
Figure 4.3 Typical Blind Shear Ram with shuttle valve (SINTEF, 2011) .....	21
Figure 4.4 Annular preventer (Group, 2011).....	22
Figure 4.5 Diagram of control pod operation system (SINTEF, 2011).....	23
Figure 5.1 Shear test on old (left) and new (right) pipe (West Engineering Services Inc., 2002) .....	37

**List of tables**

Table 3.1 PFD (probability of failure on demand) and RRF (risk reduction factor) of low demand operation for different SILs as defined in IEC EN 61508 are as follows.....10

Table 3.2 The seven-level TRL scale (Lovie, et al., 2014).....12

Table 4.1 Overview of BOP system failures (Holand & Hammad, 2012) .....27

## Abbreviations

<b>AP</b>	Annular Preventer
<b>API</b>	American Petroleum Institute
<b>BOP</b>	Blowout Preventer
<b>BSEE</b>	Bureau of Safety and Environmental Enforcement
<b>BSR</b>	Blind Shear Ram
<b>CSR</b>	Casing Shear Ram
<b>DEA</b>	Danish Energy Agency
<b>EDS</b>	Emergency Disconnect Sequence
<b>HCR</b>	Hydrocarbon Release
<b>MAIB</b>	Marine Accident Investigation Branch
<b>OGP</b>	International Association of Oil and gas Producers
<b>PFD</b>	Probability of Failure on Demand
<b>PSA</b>	Petroleum Safety Authority
<b>RAMS</b>	Reliability, Availability, Maintainability and Safety
<b>ROV</b>	remote operated vehicle
<b>RRF</b>	Risk Reduction Factor
<b>SIL</b>	Safety Integrity Level
<b>SIS</b>	Safety Instrumented System
<b>SQAIR</b>	Shell's Quality and Inspection Requirements
<b>SRS</b>	Safety Requirement Specification
<b>TRL</b>	Technology Readiness Level
<b>VBR</b>	Variable Bore Ram
<b>WCID</b>	Well Control Incident Database
<b>WOAD</b>	Worldwide Offshore Accident Databank

# Chapter 1

## Introduction

### 1.1 Background

The petroleum industry contains the processes of exploration, extraction, refining, transporting and marketing petroleum products. Petroleum is a critical concern for many nations, since it is important to maintenance the industrial civilization and vital to many other industries. Petroleum industry involves enormous sums of money and may be the most sever hazard to the environmental protection. Hence, oil and gas industry is required to be most reliable and safe.

The oil and gas production is based on surface and subsea well drilling. In order to achieve well control and safety, there are barriers which prevent oil and gas to leak. Primary barrier is achieved by pressure of the drilling mud. The secondary barrier is a blowout preventer (BOP). A blowout preventer (BOP) is a safety critical system used to ensure safe drilling and well interventions of oil and gas wells. The main function of a BOP is to seal the well, either in relation to normal drilling and intervention activities or in response to uncontrolled flow in the well.

The main international standards that covers BOP design, operation and testing are covered by Bureau of Safety and Environmental Enforcement (BSEE) regulations, American Petroleum Institute (API) standards and specifications and NORSOK standards. The reliability of BOP systems have been evaluated with basis in industry data, and the results presented in reports published by various organizations, for example BSEE, Petroleum Safety Authority (PSA) and SINTEF. Despite this effort, recent events, like the Deepwater Horizon accident in the Gulf of Mexico in 2010, indicates that there are still several challenges in relation to the performance of BOP systems.

## **1.2 Objectives**

A systematic approach regarding reliability, availability, maintainability and safety (RAMS) activities in all phases of BOP design and operation may be referred to as a RAMS engineering model. The main objective of this master's thesis is to propose RAMS engineering model for BOP system basing on international standards and reports, including conclusions and lessons learned from BOP failures. The thesis address the following:

- Description of main elements and function of BOP system,
- Literature study regarding BOP failures, including relevant accidents ,
- Description of typical RAMS engineering model,
- Proposal for RAMS engineering model based on international standards,
- Conclusion and recommendation for further work.

## **1.3 Scope and limitations**

The overall goal of this master's thesis is to propose a RAMS engineering model for BOP basing on literature survey. The purpose of such proposal is to organise facts, data and requirements, which are found in international and national regulations, in order to achieve one comprehensive report of RAMS requirements for BOP systems.

This master thesis is limited towards the reliability of subsea BOPs designed for application in deepwater exploration drilling. It does not concern shallow water BOPs, development drilling BOPs or workover intervention BOPs.

Finally, the literature survey was focused on BSEE, API and NORSOK regulations, since these regulations are most comprehensive and internationally recognised.

## **1.4 Structure of report**

The thesis is performed in three main steps: BOP system description, RAMS engineering model description and proposal of RAMS engineering model for BOP system. The emphasize has been made on third step, which is performed in chapter 5.

Chapter 2 gives an introduction to offshore drilling process. Chapter 3 is a description of typical RAMS engineering model. Chapter 4 presents a BOP system description and literature survey on BOP failures and accidents.

Finally, the thesis is summarised and concluded and areas for further research are presented in chapter 6.



## Chapter 2

### Offshore drilling

#### 2.1 Drilling operation

A well drilling is complex and resource consuming process, which absorbs great deal of measures, since it causes the serious hazard to environment. Drilling a well 3000 meters below the sea surface involves a lot of experienced experts from different fields of knowledge, from geologist, production engineers to rig operators, numerous equipment and complex machinery. Therefore it is most valid to make this process as safe and cost-efficient as possible. The process of drilling well, which is described below, is based on literature by Steve Devereux (Devereux, 2012).

There are several types of deepwater drilling rigs, i. a. semi-submersible drilling rigs and drillships. Mechanical equipment for drilling is placed on board. Top driver provides the torque to the drill string connected to drilling bit. The drilling bit may be lowering and rising by the derrick at the same time the well is being drilled.

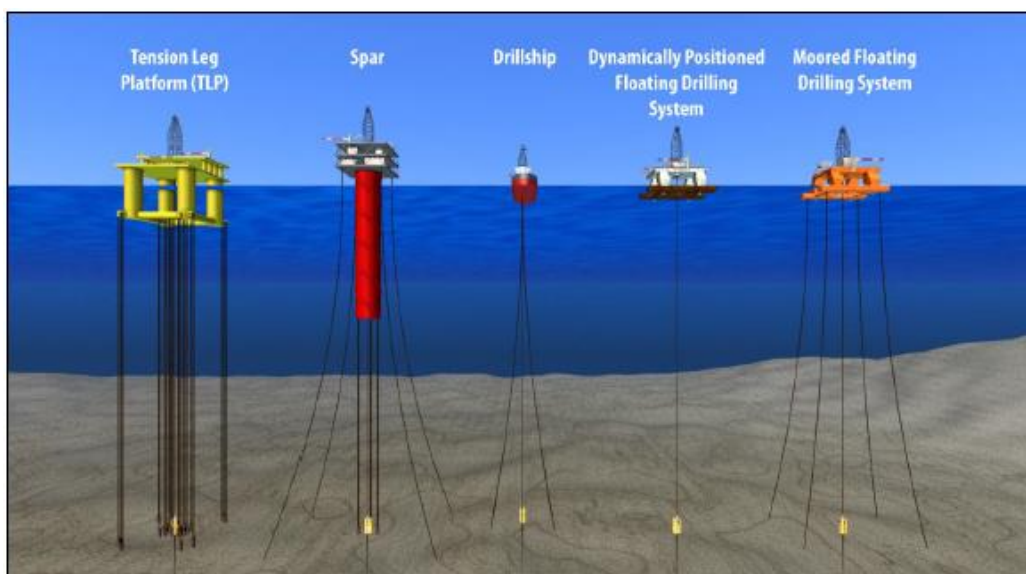

Figure 0.1 Types of rigs used in drilling operation (National Commission on the BP Deepwater Horizon Oil Spill and Offshore Drilling, 2011)

Exploration of oil and gas is based on fluid pressure. Drilling involves penetrating a range of subsurface geologic layers, which may have a formation pressure considerably higher than the pressure in the wellbore. To control pressure during drilling, the mud is applied down the drill string and up the borehole annulus, which is the space between drill string and walls of well. The mud is a special blend of oil- and water-based fluids and additives. It is also extremely hazardous for sea environment if released. (National Commission on the BP Deepwater Horizon Oil Spill and Offshore Drilling, 2011). The downhole pressure rises with the depth of the well, because of the weight of rock layers and water above. If the formation pressure is not controlled, it may result in blowout (uncontrolled release of gas and oil). The mud is the primary barrier in the drilling operations. The secondary barrier is blowout preventer (BOP), which will be described in next chapters. The drill mud performs two additional functions besides pressure control. As the mud flows down the drill string and up the annulus, it cools the drill bit and removes the drill cuttings. The mud properties are controlled on the surface by the mud loggers.

As the well goes deeper, there is a need for heavier drilling mud

to balance a higher formation pressure. In the same time, the mud puts higher pressure on the walls of well. The weight of mud may finally fracture the weaker rock layer of the well. To prevent it and cover the weaker rock, the steel casing is applied in the well and cemented in place. The steel casing has to be used several times as the well goes deeper, each has the smaller diameter than the previous one.

When the drilling reaches a reservoir, the drill bit is pulled out and the well is evaluated. The well may be completed for production or temporary abandoned after cementing the wellbore and disconnection of BOP. To extract oil or gas effectively, the additional casing must be installed in the well and a christmas tree must be installed at the top of the well.



**Figure 0.2 Drilling operation** (National Commission on the BP Deepwater Horizon Oil Spill and Offshore Drilling, 2011)

To assure safety and environmental protection in drilling operations there is a necessity to always ensure the containment function, where formation fluids are separated from the surroundings. Various measures are taken to achieve containment function, from mechanical equipment, devices, barriers and control pods to international regulations, standards and guidelines. These measures form the well integrity.

## **2.2 Well integrity**

Well integrity is defined in NORSOK D-010 as “application of technical, operational and organizational solutions to reduce risk of uncontrolled release of formation fluids throughout the life cycle of a well”. There are minimum requirements for the equipment to be applied in well integrity in NORSOK D-010 and the companies are responsible for choosing the best solutions. The term well control stands for the preventative measurements taken to avoid blowout by controlling the pressure. The blowout is one of the most serious threats for human life, safety and environment. There are two or more barriers, which prevent from the leakage of oil and gas. The primary barrier is the mud column, used to balance the pressures in wellbore (Group, 2011). Blowout preventers (BOPs) are secondary barrier in well control – the last line of defence. Designed to assist in well control, they consist of system of valves, which rapidly shut the well in the event of loss control.

## **2.3 Main phases of drilling operation**

Complexity of deepwater well’s drilling operation, which causes great risk for environment and requires enormous sums of money, induces dividing entire process on several phases.

### **Spudding the well**

Drilling process starts by “spudding” the well, which means lowering a first string of casing down to the seafloor. This first casing (called conductor casing), that is typically 36 inches in diameter or more, provides the structural foundation for the well. A wellhead assembly, installed on the top of conductor casing, remains above the seafloor. Then, using a drill string attached to the wellhead, the casing is being lowered.

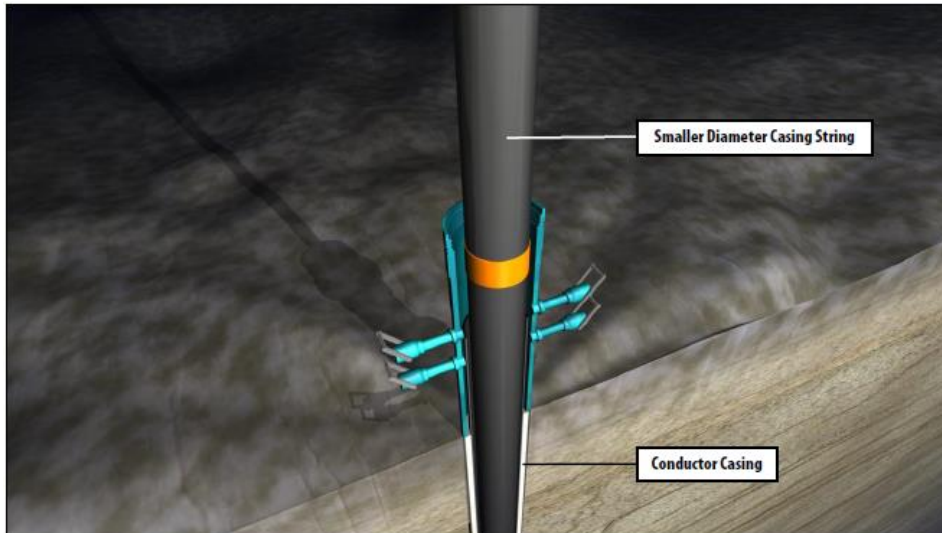

**Figure 0.3 Early drilling phases (National Commission on the BP Deepwater Horizon Oil Spill and Offshore Drilling, 2011)**

### **Setting the conductor casing and cementing**

Once the conductor casing reaches its design depth, the next, smaller diameter, casing is installed inside the bore. It extends deeper into the seabed. Next step is cementing the space around the casing in order to reinforced it and to provides the mechanical foundation for further drilling. The cement flows down the drill string and up in the annular space between the casing and the open hole.

### **Lowering the riser and BOP**

The drilling crew begin to use rotary drilling bits due to the fact that the rock layer are too strong to be removed by jetting. During rotary drilling there is a need to use mud, which may be dangerous to the environment when released. It indicates adding components to ensure well's safety: BOP and riser. A BOP, as it has been described before, is the secondary barrier in well control events. The presence of mud and increasing pressure, as drilling goes deeper, demands additional protection against leakage of oil, gas and mud.

### **Setting subsequent casing strings**

Drill mud system and rotary drill bits allows drilling through the previously set casing strings and below. The subsequent smaller diameter strings are installed inside the existing ones.

Some of them extend to the wellhead, other called liners, are attached to the previous segment of casing strings.

### **Cementing casing strings**

After installing BOP the process of cementing casing strings differs from the previous one. The cement is incompatible with drilling mud and it must be separated. There are two methods of separating: with a water-based liquid spacer and plastic wiper plug. Cement then sets in space between casing string and bore hole. When it is finished, the rig crew conducts pressure test to ensure that it has sealed the casing in place.

### **The production casing**

The well be drilled for production or as an exploration well. If it is an exploration well it is typically cemented in a process called plugging and abandoning.

After drilling production well, the operator installs a final string of production casing in the open hole section. Then the production casing are cemented and it might be perforated to allows oil and gas to flow more easily from the reservoir.

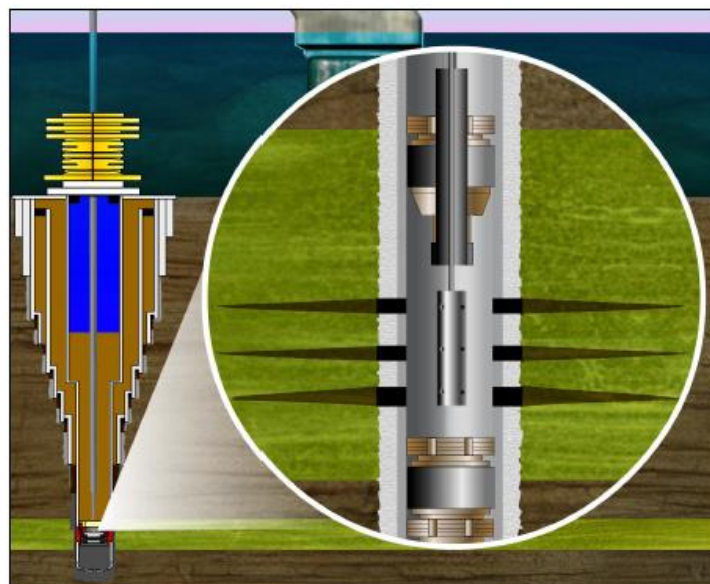

**Figure 0.4 Perforating the production casing (National Commission on the BP Deepwater Horizon Oil Spill and Offshore Drilling, 2011)**

## Chapter 3

### RAMS management concepts

#### 3.1 RAMS engineering

RAMS engineering focuses on reliability, availability, maintainability and safety of a product. The reliability may be treated like a basic for product's availability, maintainability and safety, since all these features depends on reliability of a product.

The reliability of a product is defined as “probability that an item can perform a required function under given conditions for a given time interval” (IEC 60050-191, 1990). This may be rather unclear definition of reliability, which can be assumed as the ability of a product to perform its functions. Reliability analyses can be used to improve product design in the following ways:

- To study an impact of design process on product failure rates;
- To compare alternate process for their effect on reliability;
- To determine preventive maintenance schedules and spare parts inventories;
- To enhance safety by understanding of equipment failure.

Maintainability is “the ability of an item, under stated conditions of use, to be retained in or restored to a state in which it can perform its required functions, when maintenance is performed under stated conditions and using prescribed procedures and resources” (Murthy, et al., 2008). The availability of a product is the probability to find it in proper service condition at any point of time (Wikström, et al., 2000).

Safety is defined in IEC 61508 as “freedom from unacceptable risk of physical injury or of damage to the health of people, either directly, or indirectly as a result of damage to property or to the environment.” Functional safety is a part of the overall safety that depends on a system or equipment operating correctly in response to its inputs (ISO 61508, 2005). It is method of dealing with hazards. There are two requirements to ensure functional safety:

- safety function requirement - what the function does
- safety integrity requirement - the likelihood of a safety function being performed satisfactorily

IEC 61508 specifies four levels of safety performance for a safety function. These are called safety integrity levels (SILs). The requirements need to be fulfilled to achieve each standard level. Safety integrity level 1 (SIL1) is the lowest level of safety integrity and safety integrity level 4 (SIL4) is the highest level. For products, which works on demand the SIL is calculated using two factors:

- PFD – probability of failure on demand;
- RRF – risk reduction factor.

The international standards IEC61508 establishes requirements to ensure that systems are designed, implemented, operated and maintained to provide the required SIL.

<b>SIL</b>	<b>PFD</b>	<b>PFD (power)</b>	<b>RRF</b>
<b>1</b>	0.1–0.01	$10^{-1} - 10^{-2}$	10-100
<b>2</b>	0.01–0.001	$10^{-2} - 10^{-3}$	100-1000
<b>3</b>	0.001–0.0001	$10^{-3} - 10^{-4}$	1000-10000
<b>4</b>	0.0001–0.00001	$10^{-4} - 10^{-5}$	10000-100000

**Table 0.1 PFD and RRF of low demand operation for different SILs as defined in IEC EN 61508**

### **3.2 Concepts of product life-cycle**

The authorities have established product life-cycle model for various industries. Typical life-cycle model for an offshore project consists of following phases:

1. Investment studies: feasibility, concept and pre-execution phases;
2. Investment project execution: detail engineering and construction phase and final commissioning and start-up phase;
3. Operation and de-commissioning: operational and de-commissioning phases.

There are several different and detailed product life-cycle models and activities regarding RAMS management for offshore industry, which may be found in literature. RAMS activities in life-cycle phases as described in IEC 61511 with reference to typical offshore project are as follows (OLF-070, 2004):

1. Risk analysis and protection layer design - this activity starts in concepts phase and continue into detailed design, concluding with a risk analysis report. The report should be updated at certain time intervals or when major changes occur.
2. Allocation of safety functions to protection layers- this activity starts in pre-execution phase and concludes in the detail engineering phase with a report.
3. Safety requirement specification (SRS) for safety instrumented system (SIS) - this activity starts in pre-execution phase and concludes in the detail engineering phase with a report, which should be followed up and updated in the operational and maintenance phases.
4. Design and engineering of SIS - this activity starts in the pre-execution phase and concludes in the detail engineering phase.
5. Installation, commissioning and validation - this activity starts in the construction phase and concludes with the final commissioning.
6. Operation and maintenance - this activity will be part of the operational phase of the installation.
7. Modification - this activity will be part of the operational phase.
8. Decommissioning - this activity is taking place in the decommissioning phase.

Leading oil companies are using Technology Readiness Level (TRL) scale to control project development. TRL scale, which has been adjusted to petroleum industry by RPSEA, is a practice recommended by API (API RP 17N, 2014).

Conception	TRL 0	Unproven idea - paper concepts without analysis or testing
Proof-concept	TRL 1	Proven concept - functionally demonstrated by analysis or testing



	TRL 2	Validated system concept - validated through model or small scale testing in laboratory environment
Prototype	TRL 3	Prototype tested
	TRL 4	Environment tested – prototype tested in field realistic environment
	TRL 5	System integration tested – prototype intergrated and functionally tested
Field Qualified	TRL 6	Technology deployed – prototype installed and field tested
	TRL 7	Proven technology – successful operation of technology (product)

**Table 0.2 The seven-level TRL scale (Lovie, et al., 2014)**

Based on Murthy’s product life-cycle model (Murthy, et al., 2008), the RAMS oriented model has been developed to emphasize RAMS engineering and analysis. The RAMS engineering model comprehend activities involved in achieving proper RAMS requirements for a product. It consists of three stages and three levels:

- Stage I (pre-development): concept of the product with increasing level of details.
- Stage II (development): physical product.
- Stage III (post-development): remaining part of the product subsequent to the new product development.
- Level I (business level): linking business objectives for a new product to desired product attributes.
- Level II (product level): linking product attributes to product characteristics.
- Level III (component level): linking product characteristics to component characteristics.

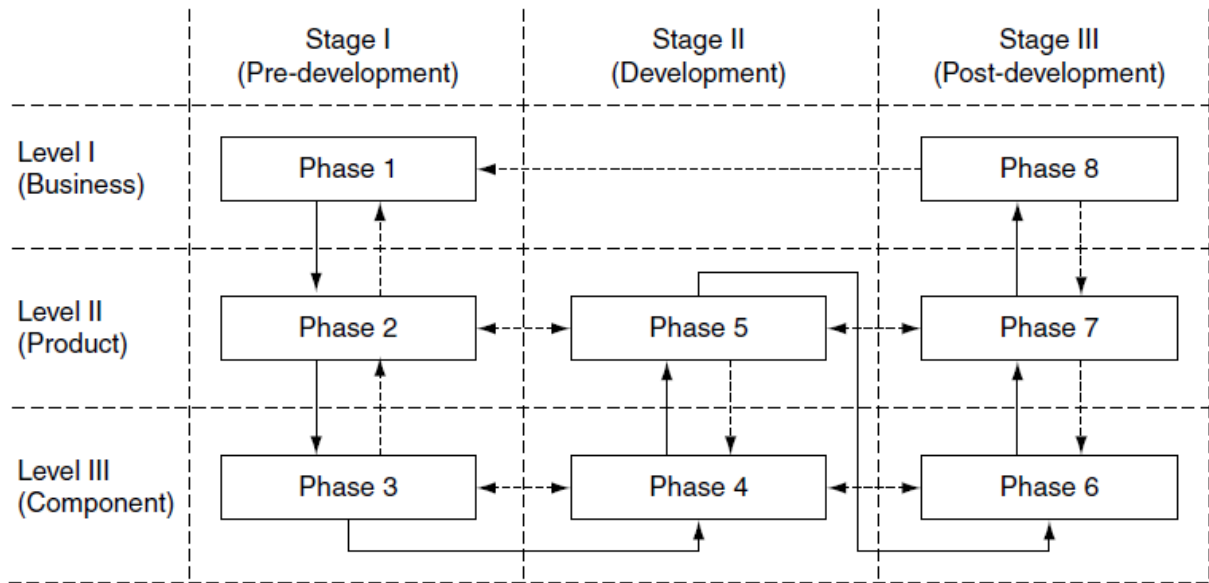

Figure 0.1 RAMS oriented life-cycle model (Murthy, et al., 2008)

The RAMS oriented engineering model is most comprehensive life-cycle model for reliability and safety studies. Taking into account this fact, it has been chosen to represent RAMS requirements for BOP system in this thesis.

### 3.3 RAMS engineering model

#### 3.3.1 Phase 1

In phase 1 the need for a new product or the need for modification of existing product is defined (Murthy, et al., 2008). The product must fulfil the business objectives and product attributes or functions, which may not be precisely specified. Product attributes or product characteristics are features of a product (size, colour, functionality, components) that make it distinct from other products. Decisions of phase 1 are made at a business level. Phase 1 involves market and competitive analysis to obtain customer's requirements. Main task of this phase is to consider all initial information and reach an agreement with customer.

When it comes to RAMS requirements, it is valid to establish them during phase 1 and update during all phases of life-cycle. The general RAMS policy should be based at the business level in order to preserve and enforce RAMS requirements of the product in next phases. All the activities, responsible organizations, departments, personnel etc. should be listed in a RAMS management plan (Lundteigen, et al., 2009). It is valid to establish RAMS specification with references to all standards, governing documents, directives, regulations

regarding each phase of the product life cycle. It is important to take into consideration previous product development experiences to find hazards and failures related to similar products.

For standard products, the RAMS requirements depend on producer, while for custom-built products, they may be proposed by a customer safety specification. In both cases, RAMS specification should follow the intended usage, support, testing and maintenance of the product.

### **3.3.2 Phase 2**

Phase 2 along with phase 3 are the most important phase for the producer, since desired functions and requirement for a product are allocated in this phase. The aim of phase 2 is to convert the general description of product's performance from phase 1 into certain product's physical features. It may be valuable to develop a primary product design of the system, its sub-systems and components to facilitate allocation of detailed RAMS requirements. It is suggested to use one of reliability allocation methods to achieve proper overall reliability target.

Phase 2 includes designing of a system or product, since it is valid to perform RAMS analyses to predict product actions. Reliability analyses may include, for example establishing model and making preliminary reliability predictions calculating probability of failure on demand (PFD) based on reliability data from previous projects. Other analysis may regard allocating reliability targets to sub-systems. It is valid to establish reliability target for component when ordering from sub-contractor (Murthy, et al., 2008).

Performing maintainability analysis controls if the product has sufficient features that facilitate maintenance and testing, for example how difficult is to get access to some parts. Safety analyses focus on hazards for humans and environmental. Availability analysis checks how maintenance, testing or false activation may affect the availability. RAMS analyses shall be included in RAMS management plan.

### **3.3.3 Phase 3**

Phase 3 is the last phase of pre-development phases in RAMS model. It involves detailed design of product and preparation of initial product construction and testing (Lundteigen, et al., 2009). An entire product might be considered as a system with number of sub-levels (sub-systems and components) (Murthy, et al., 2008). The basics of phase 3 are

sub-systems and components of a designed product. All requirements and functions from phase 2 should be allocated in individual components ensuring that the product has the required characteristics. The subcontractors might also be involved in phase 3 when there is a need to order the individual component.

Preliminary specification might be used as a basis for component's specification to be purchased. It might be difficult to define which particular component is responsible for specific function. Thus, Murthy et al. proposed the functional analysis to allocate requirements as the project evolves. As the project has a hierarchical nature of desired performance and desing options it may be described as follows:

$F_j$  – desired function on level  $j$

$DP_j$  – desired performance on level  $j$ , which may be attainable by design option (solution)  $DS_j$ , which is defined by:

$SP_j$  - specification

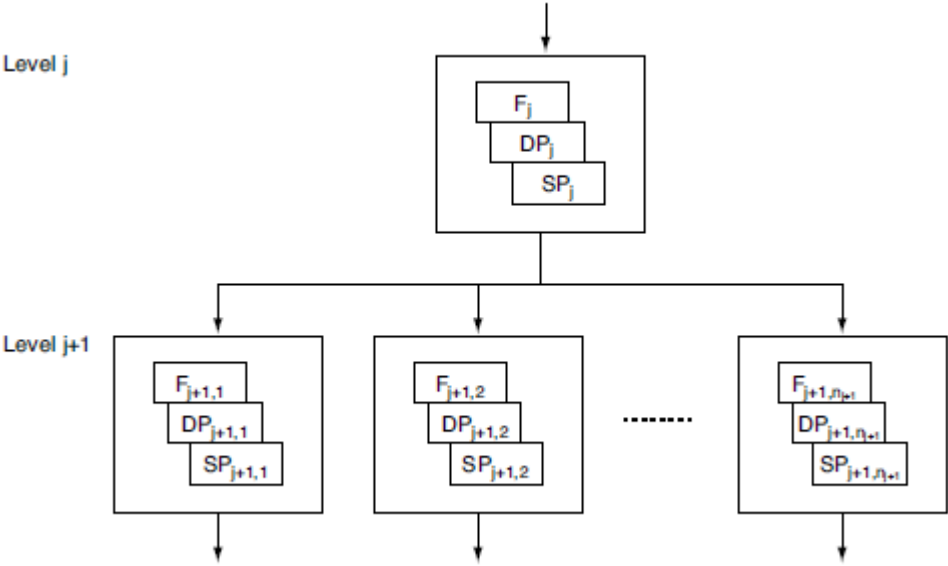

Figure 0.2 Hierarchy of functions, requirements and solutions (Murthy, et al., 2008)

However, as the production of components advances, the detailed product design specification might be develop. It is valid that the specification includes regulations, which may be needed for diagnostics and component's action in fault conditions. In order to develop specification, there is a need to control the contractors and verify if components meet the RAMS requirements during all phases of their life-cycle. It might be more cost-effective than control of finished component. It is also important to update reliability, availability and

maintainability analyses from phase 2 with the new information on component's characteristic as the production develops.

Component's safety depends not only on their features (e.g. sharp ends) but also on the way they will be assemble and install. Maintaining and updating the critical items and hazards list is important to ensure safety of entire product. Developing plans for assembling, installing, then testing and maintenance of a product might also be helpful to fulfil the RAMS requirements.

### **3.3.4 Phase 4**

In phase 4 and 5 the product's operational functions are verified. Phase 4 starts with building a prototype and testing it in controlled environment. The building process starts with components, proceeds through sub-levels and finishes in a final product. (Murthy, et al., 2008). For mass-production products, a prototype may be an entire product. However, for one of a kind products it is more cost-efficient if the prototype is a construction of some particular sub-systems or assemblies, which may be most relevant for a product. The testing in phase 4 may be limited, since it is conducted often in laboratories.

The prototype, built using new technology based on existing guidelines and procedures, requires involving its data in RAMS specification. If it is an entirely new idea, its performance shall be tested and all the data shall be included in RAMS specification and RAMS plan management. It is valid to follow qualification process for new technology (API RP 17Q, 2010).

A prototype may be controlled in wide number of functional and operational tests to ensure that it meets RAMS requirements. If a component does not meet the desired requirements, it shall be developed to improve the performance and then tested again. The phase 4 may include number of test-fix-test cycles to achieve the aimed performance of a component, sub-system and assembly. After completion of this process, the prototype is released for field testing, which is phase 5.

Tests should reveal all the systematic failures and new hazards that have not been foreseen in previous phases. It might be good idea to perform various types of reliability testing, for example accelerated testing to expose problems that product may have in over-stress situations, however it may be not cost-efficient.

**Accelerated testing** – testing under conditions where higher stresses than the nominal values are applied. It reduces the time required for testing. Stress that accelerates may be applied in many forms, i. a. high/low temperature, humidity, voltage, electrical current, vibration, fatigue etc. (Murthy, et al., 2008)

The product safety analysis shall be updated with all the valid data gained in the testing. The updates of analyses should be included in RAMS specification.

### **3.3.5 Phase 5**

Phase 5 is also a testing phase but consists of operational testing. Since, the testing in phase 4 is limited, in this phase the product's prototype may be released to small number of customers in order to get customer's assessment of the product features (Murthy, et al., 2008). The customer perspective may reveal additional failures or hazards of a product to be fixed.

For one of a kind product, phase 5 may be about testing in operating environments. Influence from operating environment may reveal additional hazards, which contribute to improvement of product's reliability and safety (Lundteigen, et al., 2009). The test should be performed under various operational and environmental conditions, such as temperature, pressure, humidity etc. The test may not include the entire product, but just some components, sub-systems or their assemblies.

The test-fix-test cycle also appears in phase 5. If the prototype after few cycles functions properly, the production of a product begins. Results of tests should be included in RAMS specification of product.

### **3.3.6 Phase 6**

Phase 6 covers the manufacturing of the product. For standard products phase 6 is a large scale production, while for custom-built products it is final construction. In both cases, the production process must be adapted to not to introduce any new failures or hazards, so that final product meets with RAMS requirements. If the production is properly adjusted, the full scale production can start (Murthy, et al., 2008).

Product batches shall be tested to eliminate all defects, assembly errors and early failures. To achieve that, an effective quality control is needed through all phases of production process. If, during quality tests, a serious number of items do not meet desired safety standards, the root causes shall be find (Andersen & Fagerhaug, 2006). It might be caused by components quality or production process.

In phase 6 may be important to “perform safety analyses of scheduled activities of phase 7 that may expose humans or environment to risk, for example activities related to operation, cleaning, testing, maintenance and disposal” (Lundteigen, et al., 2009).

### **3.3.7 Phase 7**

This phase focuses on actual field performance of a product and customer’s evaluation of it. The variability in usage intensity, operating environment and due care should be considered during the assessment of performance (Murthy, et al., 2008). The actual performance may be evaluated using data from warranty claims, customer complaints, sale of spare parts etc. According to ISO 12100 (ISO 12100:2010, 2010) use of a product may include: setting, teaching/programming, operation, cleaning, fault finding, maintenance, overhaul/repair, testing and dismantling of a product.

The product’s RAMS performance is also challenged and tested in the field (Lundteigen, et al., 2009). Regular inspections, function testing and proper maintenance shall be provided to ensure RAMS requirements. All data gained during testing and customer’s feedback should be collected and evaluated. It might be also valid to update hazard list. For one of a kind products the data may be shared between companies, which are using the same product to achieve its optimal performance.

### **3.3.8 Phase 8**

Phase 8 is the final phase of the RAMS engineering model. Here the performance of a product is evaluated from overall business perspective. The business assessment may be evaluated basing on costs such as profits from sales, warranty costs, return of investment, bad reputation etc. that is collected on a periodic bases (monthly, quarterly or yearly) (Murthy, et al., 2008). These analyses classified if the final product meets the desired RAMS requirements. The main objective of phase 8 is to obtain organizational learning and insights that may be valuable for development of a new product (Dhudsia, 1997).

Phases 7 and 8 occur parallel in time. However, phase 7 focuses on the performance of a product from engineering and development side, while phase 8 involves strategic marketing and management decisions based on evaluation from phase 7 (Lundteigen, et al., 2009).

# Chapter 4

## Blowout preventer

### 4.1 BOP function

The BOP system is an integral part of drilling operations. Drilling involves penetrating a range of subsurface geologic layers, which may have a formation pressure considerably higher than the pressure in the wellbore. The pressure increase is caused by an influx of formation fluids into wellbore. If the formation fluid starts to flow in the well, the barrier is activated to seal off the annulus. This stops mud from leaving the well at the seabed. As fluid enters the well, pressure in it increases. When the BOP is closed, the pressure in the well may stabilize. By removing all the influx and replacing the old mud with the new, which is heavy enough to attain proper pressure, the primary control is restored. Besides being well barriers, BOPs are also used in various operational tasks, e.g. casing pressure and formation strength tests.

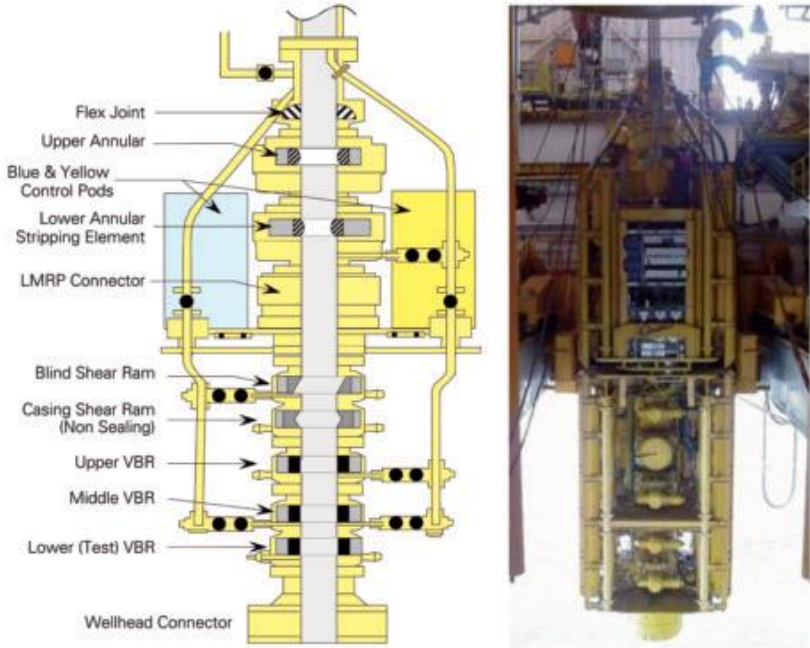

Figure 0.1 Diagram and photograph of BOP system on Deepwater Horizon (BP, 2010)



## 4.2 Main system elements of BOP system

The BOP system uses individual rams, valves and piping to maintain the pressure control in a wellbore. A typical BOP system consists of five to six ram-type BOPs, one or two annular-type BOPs and valves, which are hydraulically operated. Main system elements are described below.

### Variable bore rams

VBRs are metal bars with circulated ends designed specially to close the well by tightening around the drill pipe and sealing the annulus. Variable-bore pipe rams can accommodate to wider range of outside diameters than standard pipe rams, but typically with some loss of pressure capacity and longevity.

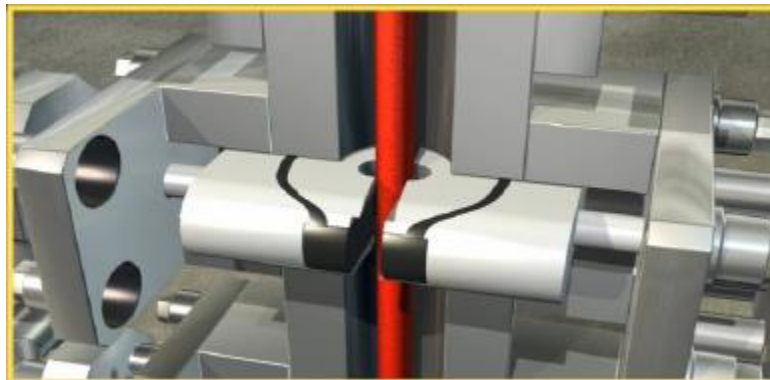

Figure 0.2 Variable Bore Ram (Group, 2011)

### Casing shear rams

CSRs are designed to shear casing, however they are not able to seal the wellbore. They cut drill pipe or casing in an emergency situation when the rig needs to disconnect quickly from the well. They are able to shear larger pipes than a BSR.

**Blind shear rams**

BSRs are designed to be the last line of defence in case of blowout (Group, 2011). It is a closing and sealing component of BOP. Firstly, it shears the tubular in the wellbore, then seals off the bore. Hydraulic fluid, which enters the shuttle valve from one of the control pods, causes a piston to push the two opposing ram blocks with cutting edges. Once the rams has cut off a drilling pipe and closed the well, they are prevented from any movement by a wedge lock. The pressure from oil, gas or mud below and behind the ram helps to keep the ram closed (SINTEF, 2011). However, BSR cannot cut the tool joints, therefore it is most valid to monitor their location.

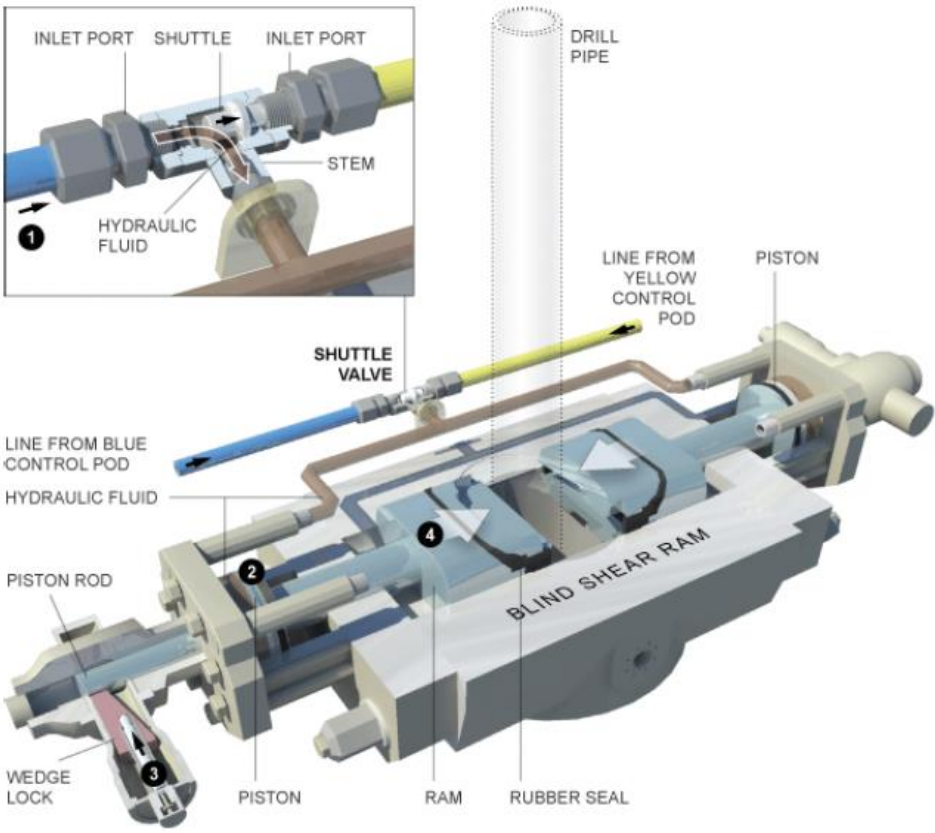

**Figure 0.3 Typical Blind Shear Ram with shuttle valve (SINTEF, 2011)**

## **Annular preventers**

Annular preventers are positioned above ram preventers, since they are not typically rated to working pressures as high as those of the ram preventers. Annular preventers are designed to close around a wide range of tubular sizes and can seal the wellbore if no pipe is present to seal around the pipe to prevent a well from blowing out.

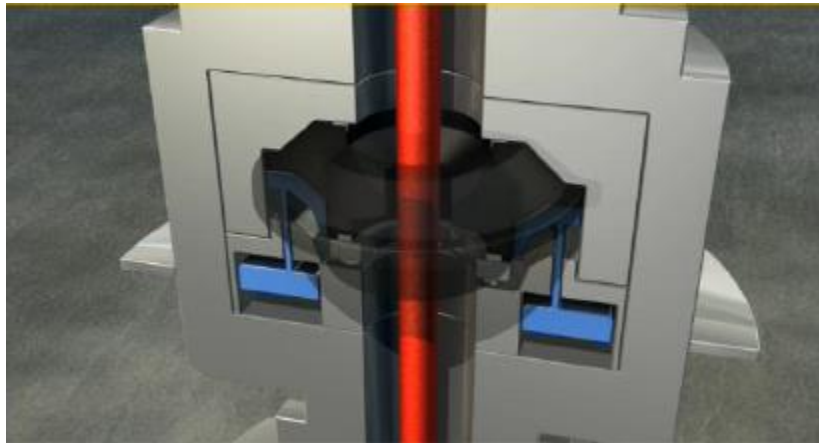

**Figure 0.4 Annular preventer (Group, 2011)**

Annular preventer consists of elastomeric packing units that may be used to encapsulate drill pipe and well tools to completely seal a wellbore. Packing units can be compressed to such an extent that the bore is entirely closed, when there is no drill pipe or well tools in the well.

## **Flex joint**

Flex joint is located at the top of BOP stack. It is a “steel and elastomer assembly that has a central through-passage equal to or greater in diameter than the riser bore and that may be positioned in the riser string to reduce local bending stresses” (ISO 13624:1, 2009).

## Control Pod

A subsea control module (control pod) is normally installed directly on the BOP stack. It is the interface receiving and transmitting signals between the rig and subsea equipment. The control pod contains pilot valves powered by hydraulic fluid and electric power. The upper part of control pod has electrical elements and the lower part has hydraulic valves. The pod also includes electronic components that are used for control, communications and data-gathering.

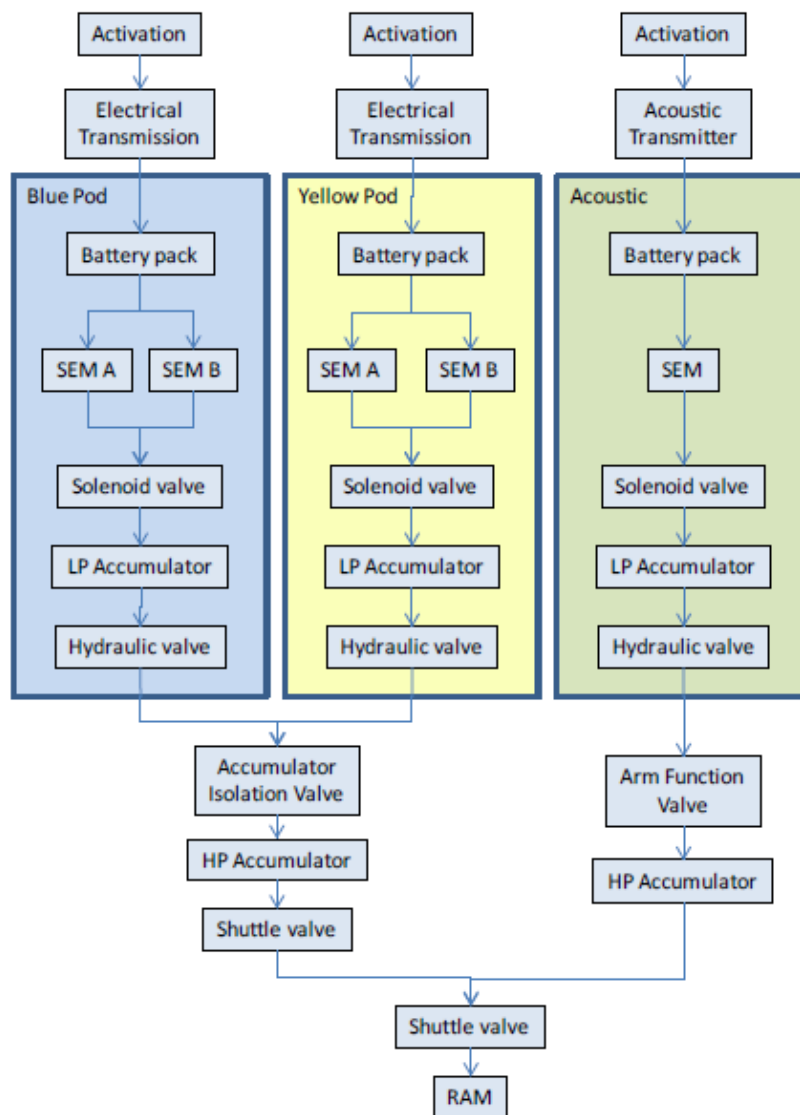

**Figure 0.5** Diagram of control pod operation system (SINTEF, 2011)

There are two control pods: yellow and blue, which are activated separately (only one pod at a time). They should have two separate accumulators with sufficient power to seal the well within maximum 45 seconds. (SINTEF, 2011) (API RP 17A, 2011).

## **Low Marine Riser Package**

The upper section of a two-section subsea BOP stack consisting of a hydraulic connector, annular BOP, ball/flex joint, riser adapter, jumper hoses for the choke, kill, and auxiliary lines, and subsea control pods. This interfaces with the lower subsea BOP stack. (API RP 16Q, Recommended Practice for Design, Selection, Operation and Maintenance of Marine Drilling Riser Systems, First Edition, November 1993 (Reaffirmed August 2001))

## **Wellhead Connector**

It is a “hydraulically-operated connector that joins the BOP stack to the subsea wellhead” (API SPEC 16D, 2004).

## **4.3 BOP failures and consequences**

### **4.3.1 Hazards related to offshore drilling**

Offshore oil drilling entails the hazard of a major accident with severe consequences:

- Loss of life and health for workers;
- Pollution of the environment;
- Direct and indirect (falls in price of company’s shares) economic losses;
- Decrease in energy supply.

The emission and pollution during normal operation activities, regulated by international conventions, should be distinguished from environmental pollution caused by accident. Pollution from normal operation results in small quantities of pollutants during long periods, when the accidental events release great amount of them in the sea in short period, which is hazardous.

The main accident’s hazards include:

- fire, after ignition of released hydrocarbons;
- explosion, after gas release, formation and ignition of an explosive cloud;
- oil release on sea surface or subsea.

The primary barrier, which prevents gas and oil to release in the sea, is drilling mud which cause proper pressure in the well. If the primary barrier breaks, the blowout preventer shall be activated. However, the BOP systems do not work properly each time.

### **4.3.2 Availability of data sources on failures and accidents**

There are several national and international databases regarding failures and accidents during drilling operation, as following:

- Hydrocarbon Release Database (HCR) – United Kingdom;
- Marine Accident Investigation Branch (MAIB) – United Kingdom;
- Danish Energy Agency (DEA) – Denmark;
- Petroleum Safety Authority (PSA) databases – Norway;
- SINTEF Offshore Blowout Database – Norway;
- Well Control Incident Database (WCID) - International Association of Oil and gas Producers (OGP);
- Worldwide Offshore Accident Databank (WOAD) – Det Norske Veritas - Germanischer Lloyd (DNV-GL).

#### **UK – Hydrocarbon Release Database**

The HCR Database System contains supplementary information on all offshore releases of hydrocarbons reported to the HSE Offshore Division from 1 October 1992.

#### **UK - Marine Accident Investigation Branch**

The MAIB database includes information about all UK registered vessels all over the world and vessels on the UK territorial waters. MAIB maintains the database since 1991 to date.

#### **Denmark - Danish Safety Authority**

Any fatality or accident occurring on offshore installation, significant damages to structure or equipment and near-miss incidents shall be reported to the Danish Safety Authority by the principal employer, for example a company in charge of drilling operation.

Statistics on accidents and near-miss incident are published annual in a report on oil and gas production in Denmark.

#### **Norway - Petroleum Safety Authority Databases**

All accidents that result in death or injury and offshore incidents shall be reported to PSA by operators. PSA investigate 6-9 most serious incidents each year. Reports with descriptions of investigated accidents are published on PSA website.

### **Norway - SINTEF Offshore Blowout Database**

SINTEF Offshore Blowout Database includes information about more than 570 worldwide offshore blowouts and well releases that have occurred since 1955. It is comprehensive database for blowout risk assessment including accident's descriptions and production exposure data with focus on the US Gulf of Mexico Outer Continental Shelf, Norwegian waters, and UK waters. The incidents are categorized in several parameters, emphasizing blowout causes. The database contains 51 different fields describing each event.

### **OGP – Well Control Incident Database**

The OGP has been established to identify areas for improvement of oil and gas industry across the whole cycle of well planning, construction, operation and abandonment. The main objective of OGP is to provide a formal and active committee to share good practice related to well integrity and safety matters, for example analysing incidents and disseminating lessons learned through database. OGP members report well control incidents and near-misses into to WCID, shared data are available only to them.

### **DNV-GL - Worldwide Offshore Accident Databank**

DNV-GL operates one of the main offshore accident information databases. WOAD contains more than 6000 events from 1975, including accidents, incidents and near misses from UK, Norwegian and Gulf of Mexico sectors. Data, collected from public sources, newspapers and official publications, contains number of parameters (name, type, operation mode, accident's description etc.). It allows calculating the accident rates for different accidents and installation, rig or platform types.

#### **4.3.3 BOP failures**

The comprehensive studies on BOP failures are conducted by Holand basing on incident data from, for example SINTEF database ( (Holand i Hammad, 2012) since 1992. The overall reliability of BOP system has improved comparing with the previous studies, however, the average downtime per BOP-day for present and previous studies are at the same level. It is likely to be caused by the increase in repair time for modern wells, which are deeper than in the past.

<b>BOP subsystems</b>	<b>BOP days in service</b>	<b>Item days in service</b>	<b>No of failures</b>	<b>Total lost time</b>
<b>Annular preventer</b>	15056	28150	24	2344,5
<b>Connector</b>	15056	31142	8	638
<b>Flexible joint</b>	15056	15056	1	288
<b>Ram preventer</b>	15056	77264	23	1756,5
<b>Main control system</b>	15056	15056	72	4712
<b>Choke &amp; kill valve</b>	15056	160310	4	136
<b>Choke &amp; kill lines</b>	15065	15056	17	1992
<b>Dummy item</b>	15056	-	7	1572
<b>Total</b>	15056	-	135	11320

**Table 0.1 Overview of BOP system failures (Holand & Hammad, 2012)**

45% of failures were attributed to components in BOP control system that operates various BOP functions. The control system is also causing the highest downtime of BOP subsystems. It indicates the need to improve the reliability of control system. The failure of BOP component may lead to the severe accident, as in case of Deepwater Horizon accident in the Gulf of Mexico in 2010.

#### **4.3.4 Major accidents**

##### **Ixtoc I Blowout (Gulf of Mexico, 1979)**

The day before the accident the drill bit had reached the depth of 3615 meters, where was a region of soft sedimentary soil causing reduction in the weight of the bit. It caused fracture in the well's piping resulting in a complete loss in the vital drilling mud circulation. By the time the drill bit was removed, the pressure in the column reached to extremely high and unstable level and went up the drill pipe onto the rig platform (Christou i Konstantinidou, 2012). The BOP system failed to work correctly, when operators tried to activate it. The BSR blades were unable to cut through the cross-threaded pipe, which was caused by movement of mud. The



BSR was closed on the pipe, but could not shear it, allowing oil and gas to flow to surface where it ignited. The rig collapsed and sank in the sea.

The massive contamination (by 12 June, the oil slick measured 180km by 80km) caused extensive damage along the US coast with the Texas coast suffering the greatest. The IXTOC I accident was the biggest single spill before the occurrence of Macondo accident, with an estimated 3.5 million barrels of oil released.

### **Macondo Blowout (Gulf of Mexico, 2010)**

On April 20, prior to the accident, the upper annular was closed as part of series of tests. After the conclusion of the second test, fluid from the well began spilling on the rig. The Emergency Disconnect Sequence (EDS) was noted to activate after there was an explosion – it was the last recorded control attempt from the surface.

The upper annular was founded closed. A drill pipe joint was located and closed between UAP and upper VBR. The forces from the flow pushed the tool joint into the UAP, which prevent it from moving horizontally. However, it was able to move vertically and that caused buckling and bowing of the drill pipe. The drill pipe located between shearing blades of BSR was off-centred, outside the corner of the blade. The drill pipe trapped between the blocks, which prevented BSR from fully closing and sealing the well, is indicated to be the main cause of a Macondo blowout according to DNV report (DNV, 2011). The leak lasted for 87 days and resulted in 11 fatalities, 17 injuries and a serious environmental disaster.

There was a series of attempts to stop the oil from enter the Gulf of Mexico, from April 21 to September 19, including (DHSG, 2011):

1. Closing BSR and VBR using ROV intervention –failed;
2. Closing end of the drill pipe on seabed – succeed;
3. Capturing the oil leaking from the broken riser with an insertion tube – partially succeed;
4. Injecting heavy mud into the BOP – failed;
5. Removing the remnant riser at the BOP top and bolting on a sealing cap with a BOP above – succeed;
6. Reducing pressure by pumping heavy kill mud into the well – succeed.

Deepwater Horizon Study Group analysed data from the accident regarding rig, installation, equipment, operational activities etc. and included in its report (DHSG, 2011) the primary

causes of Macondo accident. The first cause was associated with the decision to prepare well for production (cementing operation) without fully consider the specific geology and difficult conditions in the Gulf of Mexico. The second cause regarded procedure and processes used for temporary abandonment the well, which allowed hydrocarbons to enter the well. The third cause was associated with failed attempts to control the well which resulted in ignition of hydrocarbons.

The U.S. Chemical Safety and Hazard Investigation Board in its report (U.S. Chemical Safety and Hazard Investigation Board, 2014) mentions additionally the failures in both redundant control pods responsible for initiating the deadman system. The blue pod was not wired properly, which caused the draining of the critical battery that is necessary to power the solenoid valves during the deadman sequence. A solenoid in the yellow pod was critical mis-wired. The mis-wiring should have caused the redundant coils to oppose one another, but a drained battery resulted in lack of power in one of the coils. This left the remaining coil to activate unopposed and to initiate the BSR as part of the deadman sequence. The BSR only partially sheared the off-centre pipe, but did not seal the well.

In both accidents the BOP system failed to work properly. Although the Ixtoc I Blowout happened 31 years before the Maconodo accident the cause of both is the fact that the BSR was not able to fully shear and seal off the well. Each accident resulted in great damage to human life and health, as well as the environmental severe pollution. Even if the reliability of BOP system has improved over the years, there is still a great need for improvement of production, testing and RAMS assessment of each BOP component. The one solution is to shear knowledge and good practice between oil industry companies in unlimited measure. All hazard events should be reported, including (Christou i Konstantinidou, 2012):

- unintended release of hydrocarbons;
- loss of well control, or failure of a well barrier;
- failure of a safety critical element;
- significant loss of structural integrity, or loss of protection against the
- effects of fire or explosion;
- any fatal accident; any serious injuries to 5 or more people in the same
- accident;
- any evacuation of non-essential personnel;

- a major accident to the environment.

Collection of data is necessary for effective lessons learning and obtaining a clear picture of risk possibility. The risk assessment, specifications and regulations regarding RAMS requirements should be based on reliable and solid data.

## Chapter 5

### Proposal of RAMS Engineering model for BOP

#### 5.1 Phase 1

In phase 1, a need for a new product or a need for modifications of an existing product are identified. After recent events, e.g. accident of Deepwater Horizon in the Gulf of Mexico (2010), there is a need for improvement of BOP system. It may be necessary to standardize and develop the international guidelines and regulations for BOP technology. There are several regulations regarding BOP systems, for example NORSOK standards, BSEE CFR regulations, API specifications. These should be improved all the time in order to achieve proper RAMS requirements. Examples of improvements for BOP system, which may be valuable to consider in designing new generations of BOP stacks:

replacing the CSR by a second BSR (Holand & Hammad, 2012),

BSR, which is able to cut tool joints (SINTEF, 2011).

Blowout preventers are one of a kind products, ordered by certain customer, however the BOP specification and requirements are established in international standards and regulations. The regulations, guidelines, standards and reports should be included in RAMS specification, which should be updated through all phases of life-cycle of BOP system. BOP performance should be characterised by its:

Functionality – BOP function in certain time;

Reliability - probability that an item can perform a required function under given conditions for a given time interval;

Survivability – BOP ability to withstand the stress under specified demand situations.

Reliability and availability performance of BOP may be estimated using fault tree analysis (FTA) as in the report by Holand et al. (Holand & Hammad, 2012). However, the FTA models developed in mentioned report apply to a static situations.

In the initial phase the customer delivers information about concept evaluation, scope, hazard and risk analysis and allocation of ordered BOP stack. It is valid to focus on the conditions and environment, which the BOP system works in. There are many dynamic factor, which may have an impact on BOP functions, for example type of rig, load of the rig, temperature, pressure or the water depth.

Phase 1 also may focus on general safety requirements for BOP. In OLF 070 there is an argumentation that “setting a SIL 3 level to either function would lead to a significant increase in the standard for drilling BOPs” (OLF-070, 2004).

## **5.2 Phase 2**

General functions and requirements for BOP from phase 1 are determined and allocated into product particular characteristic in phase 2. Objective of phase 2 is to transform the desired performance into sub-systems and components of product. (Lundteigen, et al., 2009). There are certain functions and components of BOP that should be accomplished by a producer, which are described both in BSEE regulations and NORSOK standards. The following design requirements are found in BSEE’s code of federal regulations (BSEE, 2015):

- At least four remote-controlled BOP rams: one AP, two PR/VBR and one BSR;
- Dual-pod control system;
- Accumulators, which should provide ‘fast closure’;
- ROV intervention capability and trained ROV crew;
- Autoshear and deadman system for DP rigs;
- Side outlets for separate kill and choke lines.

In comparison to the BSEE regulations, which are the most internationally recognised regulations for design, operation and maintenance of BOP, the NORSOK D-001 regulation notes additional following requirements (Strand & Lundteigen, 2015):

- LMRP disconnection system;
- Two shear rams, at least one capable of sealing;
- Shear ram that can shear casing and tool-joints for DP vessels;
- For MODU the BOP shall be equipped with two annular preventers;

In phase 2, level of safety requirements for BOP components may also be established. “It would also be necessary to include additional rams in standard BOP assemblies. (...) As a minimum the SIL for isolation using the annulus function should be SIL 2 and the minimum SIL for closing the blind / shear ram should be SIL 2” (OLF-070, 2004).

The aim of phase 2 is to allocate detailed RAMS requirements into characteristics. Reliability allocation may be used to achieve that aim. Reliability allocation (apportionment) is a process of allocating product reliability requirements to certain components (Holand & Hammad, 2012). Preliminary reliability allocation may be based on performance data of similar products, data regarding BOP performance may be found in Holand’s reports (Holand & Hammad, 2012).

For complicated products, such as BOP system, the reliability allocation may be an important and useful way to achieve RAMS requirements. The benefits of reliability allocation are (Yang, 2007):

- The components of BOP are planned, designed, manufactured and tested by various subcontractors. The objective is to deliver to customer a final product with required reliability. To accomplish this, every to every part should be assigned particular reliability target.
- A quantitative reliability target obligates subcontractors to manufacture a component, which fulfil RAMS requirements.
- Reliability allocation requires classification of components and product’s hierarchical structure.
- The output of reliability allocation process may be an input to other RAMS activities, for example designing proper tests.

Reliability allocation may be useful also when the item is not able to fulfil required reliability. It may indicate that the special maintenance, for example parts replacement, is required. The maintainability of a product is one of a criterion, which has an impact on reliability and should be considered in reliability allocation (Wang, et al., 2001). The other factors may be cost or complexity of a component, as well as the frequency and critically of its failure. It is valid to establish criteria to choose right reliability allocation method.

There are several methods of reliability allocation. Beneath, some of them are described and decided, which may be the most proper for BOP system.

### **Equal apportionment method**

Equal apportionment method is one of the simplest reliability allocation methods. It assumes that each component has exponential failure distribution. It treats all criteria equally for all components within system and sets a common reliability target to achieve overall system reliability requirement. It may be used in early phases of product life-cycle or when there are no historical data for certain component. However, it is too simple and naive to be used in designing BOP system.

### **ARINC Apportionment Method**

The ARINC (Aeronautical Research Inc.) approach assumes that all components are connected in series, independent of each other, exponentially distributed and have a common mission time. Reliability allocation is based on failure rates of individual components. The ratio of one component's failures per month to sum of failures per month of all components is the criterion to allocate proper reliability target.

The ARINC method may be proper for BOP system also on early phases. It might be too simple to allocate right reliability, since it assumes that components are independent of each other and it does not consider the importance of each component.

### **AGREE allocation method**

The AGREE allocation method considers complexity and significance of each component, thus it may be used in more complicated systems, such as BOP system. It assumes that components are in series and have exponential failure distribution. To achieve overall system reliability target the minimum allowable mean time to failure is determined. Complexity is defined in terms of modules and their associated circuitry, where each module is assumed to have an equal failure rate. The importance of each component is valued, the importance of 1 means that the subsystem must function successfully for the system to operate and the importance of 0 indicates that the failure of the subsystem has no effect on system operation.

The AGREE allocation method may be used to allocate reliability into BOP components, since it takes into account complexity and importance of each component. It might be assumed that BSR is the most significant component and should have the highest reliability target, while the VBR or fixed bore rams would have lower reliability.

### **Minimum effort method**

The principle of this method is to allocate reliability increase to the components in order to achieve the required overall reliability at least cost. There is no need to change reliability of every components, the least reliable are chosen to attain reliability target for whole system.

The minimum effort method may be also used in reliability allocation of BOP system, if some components have proper reliability and there is no need to change it.

### **Feasibility-of-Objectives Apportionment**

The feasibility-of-objectives apportionment method include four factors: : system intricacy, state-of-art of adapted technology, performance time and operational environment. These factors are measured on a scale from 1 to 10 for each component, basing on factor's impact on each component. For example, since BSR is supposed to work under high pressure, in great depth etc. the operational environment may be rated 9-10. The ratings should be assigned by the designers, reliability engineers and other relevant experts based on their knowledge and experiences. The reliability allocation is based on normalized rating (the four ratings of each component are multiplied together to attain the overall rating, which is later normalized).

The feasibility-of-objectives may be also useful to allocate reliability in BOP system, since it considers the factors, which impact the component's performance.

Summarizing, it may be valid to use several reliability allocation in order to consider all internal and external factors and criteria influencing components. Various reliability allocation approaches may help to allocate reliability in more comprehensive way.

### **5.3 Phase 3**

Phase 3 involves detailed design of components for BOP system, which combines of several sub-systems. This implies a need for ordering elements from subcontractors. This is the start of product development for components, which may include modifications of existing BOP elements and new technology development.

Due to a fact that BOP system comprises of several main components, describing special requirements for each component might be impossible in one report. In this paragraph I would like to focus on BSR, which, in my opinion, are the most important and should be the most reliable element of BOP. A BSR's function is to shear a drill pipe and seal off a well in the event of loss control to avoid releasing oil and gas. It is sometimes called the last line of defence.



Despite being a valid component of BOP system, requirements for BSR are not thoroughly described. I did not find any particular requirements for BSR in NORSOK D-001 or D-010 besides a general note that they must be capable of sealing the well. BSEE Federal Regulations mention that “the blind-shear rams must be capable of shearing any drill pipe (including workstring and tubing) in the hole under maximum anticipated surface pressures” (BSEE, 2015).

API specifications include more requirements for BSRs, however they focus mainly on testing. In API Standard 53 (API Std 53, 2012) there is a paragraph about control valve, which is responsible for BSR operation, should be protected against unintentional action, yet still be operational from the remote panel.

The functional test of BSR should be performed at least once every 21 days. The low pressure for pre-deployment testing and subsea testing is the same – 250-350 psi. For pre-deployment testing the high pressure is RWP (rated working pressure - the maximum internal pressure that equipment is designed to contain or control) of ram preventers or wellhead system, whichever is lower. For subsea testing: pressure tested at casing points to the casing test pressure. During subsea test the locks should be in the locked position without closing and locking pressure.

In case of well control event, the BSR should close in 45 seconds or less. This requirement is controlled by an annual subsea testing of secondary systems: ROV and acoustics. For emergency systems: deadman, autoshear or equivalent, there is a requirement of 90 seconds or less for all components of BOP.

The BSR should not be tested with the pipe in the stack, since it is a destructive test. After well control event, if the BSR was closed and the pipe was sheared, the ram block needs to be inspected and tested as soon as operations allow.

API Specification 16A (API SPEC 16A, 2010) determines several more testing requirements for BSRs. The minimum diameters of pipes for particular BOPs, which should be sheared are specified. These tests shall be performed without tension in the pipe and with zero wellbore pressure. Shearing a pipe and sealing a well is required to be completed in a single operation. The piston-closing pressure shall not exceed the manufacturer's rated working pressure for the operating system. The manufacturer should also include in the documentation shear ram and blowout preventer configurations, pipe description (size, mass and grade), pipe's actual tensile properties, the actual pressure and force to shear the pipe.

Nonetheless, how it is described by West Engineering Services Inc., “meeting Spec 16A requirements does not by any means guarantee that a rig is operating in a prudent or safe manner” (West Engineering Services Inc., 2002). Firstly, the pipe mentioned in API Spec 16A are outdated and are not used any more in current drilling rigs. Drill pipe technology has developed over the years of drilling operations. There are two valid improvements in modernized pipes that may benefit the petroleum industry, although they have negative impact on BSR’s shearing abilities. First is the increase in pipe size and diameter. Second is development in material technology. Modernized pipes are built from reinforced metals, which have greater ductility and are harder to shear. To shear a new generation of high specific pipes, SQAIR (Shell’s Quality and Inspection Requirements), the pressure must be doubled in compare to pressure required to shear older pipes of the same weight, diameter and tensile strength. What is more, the different types of pipes cannot be visually distinguish, thus it is important to keep appropriate record.



**Figure 0.1** Shear test on old (left) and new (right) pipe (West Engineering Services Inc., 2002). Even though both pipes have the same specification, the new pipe required almost 2000 psi more to shear than the old pipe.

Other difficulty, which should be taken into consideration in modern requirements, are the environment and conditions where the BSR works. The pressure needed to shear at considerable water depth, which has also increased over the years, is rarely considered. The pressure corrections up to 500 psi were required during tests performed by West Engineering Services Inc. to account for the operating environment.

To summarize, regulations and specifications do not include great number of particular requirements for BSR, they rather mention its general function. It depends on designers and constructors, how BSRs will fulfil specific function. In API standards the requirements for testing are widely described, yet they are outdated. The new, modernize and more specific,

standard should be released, since the petroleum industry, which involves large sums of money and great hazard for the environment, is still developing.

#### **5.4 Phase 4 and phase 5**

Phase 4 focuses on testing a prototype in controlled environment, while phase 5 consists of operational tests, which controls a product's readiness. The requirements for testing BOP system and components are not separate for laboratory and field testing, thus phases 4 and 5 of RAMS engineering model for BOP are described in the same subchapter.

Since the BOP is not a mass production product, the costs of building and testing prototype may be hard. However, GE Oil and Gas ordered a BOP prototype for testing in order to develop new generation of BOPs working under high pressure and high temperature (Jacobs, 2015). Instead of building a prototype, the particular components and assemblies may be tested. This approach is used in standard and regulations which are mentioned in this subchapter.

This quotation, which is found in NORSOK D-010, applies to tests performed on components before deployment (phase 4 and 5) as well as for testing during BOP operation life (phase 7) "the selection of well testing operational methods, procedures and equipment shall be determined by considerations of safety and risk to the environment, operational efficiency and cost effectiveness. The well test operations procedure shall define and specify limitations and well barriers." Norwegian standard emphasizes the importance of proper test design in terms of reliability, maintenance and safety to ensure environment preservation and human's life and health protection.

The most thorough requirements, which I found, regarding testing BOP components are listed in API Specification 16A (API SPEC 16A, 2010). According to API Spec 16A all tests shall be conducted using water at ambient temperature as the wellbore fluid, the level of piston closing pressure shall be pressure recommended by the manufacturer not exceeding the designed hydraulic operating system pressure.

In API Spec 16A series of test are described for ram-type preventer, annular preventer and hydraulic connectors as well as for non-metallic sealing materials and assemblies installed between them. The testing procedures are described in annex C of API Spec 16A.

There are several operational characteristics of ram-types preventers that should be determined in tests, i. a.

- actual opening and closing pressure required to maintain or break a wellbore pressure seal – sealing characteristics test;
- ability of the ram packers and seals to maintain a wellbore pressure seal after repeated closings and openings – fatigue test;
- ability to control wellbore pressure while running drill pipe through the closed rams without exceeding a leak rate of 4 litre/min – stripping life test;
- shearing and sealing capability for selected pipes (test shall be performed without any tension in the pipe and zero wellbore pressure) – shear ram test.

In tests for fixed-bore pipe rams test mandrel for either small and large blowout preventers shall be used, while for VBR the test shall include maximum and minimum pipe sizes to be used in particular BOP.

For annular-type preventers tests shall determine piston closing pressure necessary to maintain a seal as a function of wellbore pressures up to full rated working pressure of the blowout preventer. This test shall be performed on a drill pipe mandrel and under open-hole conditions and shall consist of three parts to determine actual closing pressure, maximum wellbore pressure and closing pressure required to seal open hole at one-half of rated working pressure. Conditions and requirements for fatigue test and stripping life test are the same as for ram-type preventers.

Tests to verify the locking and sealing mechanisms at rated working pressure shall be performed for hydraulic connectors using an assembled connector with test stump.

Documentation regarding conducted tests, which should be the part of RAMS specification, shall include records of closing and operators pressure, number of cycles to failure to maintain a seal, wellbore pressure used during tests etc.

The operating manual shall be prepared for every ram-type and annular-type preventer. It might be a good idea to include it to RAMS management plan, as it shall contain following information (API SPEC 16A, 2010):

- operation and installation instructions;
- physical data;
- seals information;
- maintenance and testing information;

- assembly and disassembly information;
- parts information;
- storage information;
- operational characteristics summary.

Accident of Deepwater Horizon shows that meeting the testing requirements listed in API Standard 16A does not ensure safety and reliability of BOP system. The primary cause of accident was the buckling and bowing of drill pipe, which prevented BSR from sealing the drill pipe. In DNV report on Deepwater Horizon accident (DNV, 2011) the recommendations for further or additional testing regarding shearing an off-centred drill pipe are described as following:

- Field test the ability of BSR to shear and seal a section of off-centred 5-1/2 inch drill pipe;
- Field test the ability of closed annular preventer to restrain movement of 5-1/2 inch drill pipe tool-joint at the forces calculated for buckling;
- Field test the conditions required to push a 5-1/2 inch tool-joint through a closed annular element.

Summarizing, as the petroleum industry develop new technologies, for example new generation of high specification pipe (West Engineering Services Inc., 2002), the regulations and standards regarding BOP safety, maintenance, testing, reliability etc. shall be adapted for this development.

## **5.5 Phase 6**

BOP is one of a kind product, so phase 6 may focus on the final construction of BOP stack from tested components, sub-systems and assemblies. For BOP phase 6 may include also installation and evaluation of the system at site (Lundteigen, et al., 2009).

It is important to ensure that the production process will not introduce any new failures or hazards. To achieve that quality control shall be performed in every stage of production. The quality control for BOP stack should include verification of construction as well as installation at site. Quality control requirements for specific BOP's parts and equipment are widely described in API Standard 16A. In general, all equipment exposed to wellbore fluid shall meet the requirements of NACE MR0175 (NACE MR0175, 2009) and API standards. All quality work shall be controlled by manufacturer's instructions including appropriate

methodology and acceptance criteria. The methodology of quality control should be non-destructive examination with manufacturer's written instruction for NDE activities. Acceptance testing is used to decide if the materials and components received from suppliers meet the RAMS requirements (Murthy, et al., 2008). All parts shall have acceptance status indicated on them and in their records.

Quality control for pressure-containing and pressure-controlling parts according to API Standard 16A shall include following tests:

- Tensile testing
- Impact testing
- Hardness testing
- Dimensional verification
- Traceability
- Chemical analysis
- Visual examination
- Weld Non-destructive examination

Phase 6 shall be finalised with the site acceptance test witnessed by the customer. Site testing may provide realistic results if the final construction of BOP system meets RAMS requirements. Norsok D-001 (Norsok D-001, 2012) indicates the requirement to test BOP stack as a complete system, with all sub-systems integrated prior to beginning of operational phase.

Commissioning of BOP system may occur only if all RAMS requirements are fulfilled during site testing. The commissioning activities for an offshore project, for example BOP systems, are described in DNV Recommended Practice A205 (DNV RP A205, 2013) as follows:

1. Mechanical Completion – construction, installation, pressure testing;
2. Pre-Commissioning – energization, equipment running;
3. Commissioning – testing of system start up, load tests, equipment performance tests;
4. System integrated testing – complete system testing, final adjustment of alarm and measuring units;
5. Marine Seal Try – system acceptance.

## **5.6 Phase 7**

Phase 7 may focus on operation of BOP system in the field including use of a product and its dismantling. Phase 7 bases on customer's feedback, however it may be hard to get systematic feedback from BOP owners. Thus, the cross-company cooperation regarding BOP systems RAMS features should be supported. The offshore reliability data are collected for example in BSEE white paper reports.

There are several RAMS activities, besides collecting customer's feedback, that should be performed in phase 7, such as regular inspections, maintenance and testing of BOP system.

### **Inspections**

According to API Standard 53 (API Std 53, 2012), the well control equipment shall be visually inspected prior to deployment in accordance to equipment's reliability data. Inspections should be performed at least every 5 years or if the collected performance data justify different frequency. Certain well operations or conditions, such as well control events, may require more frequent inspections. The equipment, which is exposed to greater usage, for example shear blades, ram blocks etc., shall be inspected once a year. The elastomeric components shall also be controlled, as well as the surface finishes for wear and corrosion.

### **Maintenance**

API Standard 53 requires planned maintenance program with identified equipment, specified task and time intervals between these tasks on each rig. There should be a record of every maintenance, repair or replacement of equipment or assembly. Every part's replacement shall be designed for intended used and tested in operational conditions.

NORSOK D-001 additionally requires the use of standard components to ease maintenance and replacement handling.

API Standard 16D describes requirements for control pods inspections and maintenance, including for example verification of instruments accuracy, relief valve and pressure control switch settings, as well as general condition of piping systems, hoses etc.

### **Testing**

General requirements for BOP system testing during phase 7 can be found in BSEE (BSEE, 2015) and API Standard 53 (API Std 53, 2012). Both regulations includes requirements regarding pressure used in tests and test's frequency.

According to BSEE pressure tests of BOP system shall be performed:

- when installed,
- every 14 days,
- before drilling out each string of casing or liner.

The low and high pressure tests in that order shall be conducted. Low pressure test must be between 200-300psi every time. High pressure test for ram preventers must equal the rated working pressure of the equipment or be 500psi greater than calculated maximum anticipated surface pressure (MASP). For annular preventers it should equal 70% of the rated working pressure of the equipment or to a pressure approved in APD. Each test must hold the required pressure for 5 minutes.

BSEE requires conducting stump test before installation, and then the initial BOP test on the seafloor within 30 days of the stump test. Annular and ram preventers should be functional tested every 7 days between pressure tests. The interval between pressure tests of BSR should not exceed 30days.

API Standard 53 (API Std 53, 2012) claims that all components of BOP stack, besides shear rams and hydraulic connectors, shall be function tested every 7 days. Shear rams shall be tested every 21 days. As we can see, the API Standard 53 broadens requirements regarding frequency of testing all BOP's elements. The pressure testing shall be conducted:

- upon installation,
- after the disconnection or repair of any pressure containment seal (also function test is required),
- at least every 21 days,
- in accordance with owner's requirements.

API standard 53 qualifies pressure test as function test. However, function tests control the ability of BOP to carry out the tested function without testing the ability to seal off under pressure.

API Standard mentions also the need to function test all control stations and both pods before the deployment, as well as acoustic, ROV, deadman, autoshear systems. The acceptance criteria is 45-90 seconds for activation of assigned components. Requirements for subsea testing are the same.



Values of low pressures in API Std 53 are slightly different than in BSEE regulations, the pressure is about 250-350psi. each test must hold pressure for 5minutes with no visible leakage. The high pressure of all elements is RWP of ram preventer or wellhead system. The exceptional element in tables for values of low and high pressure test is the casing shear ram. There are no values for pressure test for CSR, since it is not the mandatory component of BOP system. However, the function test shall be conducted to control CSR's action.

To sum up, the more frequently the BOP stack is tested the higher availability the BOP as a safety barrier will be. It is valid to note that some parts of BOP system are more important than others with respect to testing (Holand & Hammad, 2012).

## **5.7 Phase 8**

Phase 8 focuses the BOP evaluation from the business perspective, which may include hazards for the environment and company's bad reputation caused by the BOP failure. The BOP general operation is evaluated in this phase. It is important to gather data and knowledge about BOP, which may be valuable for the development of new generation of BOP systems (Lundteigen, et al., 2009). Gaining data after BOP stacks accident is beneficial. Various reports were made after Deepwater Horizon accident, which includes valid observations and recommendation for oil and gas industry, for example DNV Investigation Report (DNV, 2011).

Phase 8 may also concern BOP stakeholders with different perspectives. The manufacturer, who designed, produced and tested certain BOP component may be interested in warranty costs. The main concern for a drilling rig owner may be the downtime amount. Thus, each BOP failure and component's reliability data should be recorded in RAMS specification. Oil company should be concerned in safety of rig, since the accidents, often causing massive loss of human life and health and environmental pollution, results in direct and indirect economical losses. Organisations related with environmental protection may also be interested in safety and reliability of BOP system, since drilling well activities carry huge risk.

It might be difficult to gain complete knowledge about every BOP failure, thus it might be valuable to establish one international database including BOP's RAMS activities, requirements and failures.

## Chapter 6

### Conclusion

#### 6.1 Summary and conclusions

Drilling operations carry out great risk for human life and health, as well as for environmental preservation. Many measures are taken to ensure well integrity and safety. One of them is pressure of drilling mud, which evens pressures of water, soil layers etc. However, if the kick occurs, the pressure of drilling mud column may be not enough to avoid the oil and gas leakage.

The secondary barrier is blowout preventer. The BOP system, sometimes called the last line of defence, has to be reliable to ensure overall safety. The RAMS requirements for BOP design, production, installation, maintenance and testing can be found in regulations and standards published by American and Norwegian authorities: API, BSEE, NORSOK, PSA etc. Comparing, these regulations are common for general BOP requirements, sometimes they differ in details, for example Norwegian regulations require acoustic control system besides standard yellow and blue control pods.

However, fulfilling the RAMS requirements does not ensure full safety and reliability of BOP system. Despite meeting the primary requirements, the BOP system of Deepwater Horizon did not work properly, which result in one of the greatest accidents in petroleum industry history with 11 fatalities, 17 injuries and massive environmental pollution in the Gulf of Mexico 2010. The main cause of accident was BSR failed to shear a drill pipe and seal off the well. The same BSR failure led to Ixtoc I blowout in 1979 also in the Gulf of Mexico. This indicates the importance of proper geological work and the need to develop RAMS requirements for BOP components.

In this thesis, RAMS engineering model was used to organise all the most important requirements for BOP system. RAMS activities ensuring RAMS requirements shall be included in all phases of life-cycle of a product. Collecting requirements and reliability data

on BOP system failures in one comprehensive report facilitates the process of improvement and development of new generation of BOP systems.

## **6.2 Recommendations and areas for further research**

It may be valuable to establish one, comprehensive, international standard for BOP system requirements on design, production, installation, maintenance and de-commissioning. Since, most of the petroleum industry companies are global, one regulation would be clearer and easier to adjust.

It is recommended to improve the standards regarding BOP components. In chapter 5, phase 3 was focused on several tests for BSR, which indicate the need to develop new tests proper for new generation of enforced drill pipe.

To further improve BOP reliability, it is also suggested that companies should work together, sharing data, experience and good practices in one comprehensive database. This could help in increasing the reliability and safety of BOP systems.

## References

- Andersen, B. & Fagerhaug, T., 2006. *Root cause analysis: simplified tools and techniques*. Second edition ed. Milwaukee, WI: ASQ Quality Press.
- API RP 17A, 2011. *Design and Operation of Subsea Production Systems*, s.l.: s.n.
- API RP 17N, 2014. *Recommended Practice for Subsea Production System Reliability, Technical Risk & Integrity Management*, Houston, TX: OTC.
- API RP 17Q, 2010. *Subsea Equipment Qualification*, s.l.: API.
- API SPEC 16A, 2010. *Specification for Drill-through Equipment*, s.l.: s.n.
- API SPEC 16D, 2004. *Specification for Control Systems for Drilling Well Control Equipment and Control Systems for Diverter Equipment*. s.l.:s.n.
- API Std 53, 2012. *Blowout Prevention Equipment Systems for Drilling Wells*, s.l.: s.n.
- BP, 2010. *Deepwater Horizon Accident Investigation Report*, s.l.: British Petroleum.
- BSEE, 2015. *Federal Regulations*. s.l.:s.n.
- Christou, M. & Konstantinidou, M., 2012. *Safety of offshore oil and gas operations: Lessons from past accident analysis*, s.l.: Joint Research Centre European Commission.
- Deepwater Horizon Study Group, 2011. *Final Report on the Investigation of the Macondo Well Blowout*, s.l.: s.n.
- Devereux, S., 2012. *Drilling technology in nontechnical language*. Tulsa: PennWell Corp.
- DHSG, 2011. *Final Report on the Investigation of the Macondo Well Blowout*, s.l.: Deepwater Horizon Study Group.
- Dhudsia, V., 1997. *Guidelines for Equipment Reliability*. s.l.:SEMATECH.
- DNV RP A205, 2013. *Offshore Classification Projects - Testing and Commissioning*, s.l.: Det Norske Veritas.
- DNV, 2011. *FORENSIC EXAMINATION OF DEEPWATER*, s.l.: Det Norske Veritas.
- DNV, 2011. *Forensic Examination of Deepwater Horizon Blowout Preventer. Volume I Final Report*, s.l.: Det Norske Veritas.

DNV-RP-A203, 2011. *Qualification of New Technology*, s.l.: Det Norske Veritas (DNV).

Group, D. H. S., 2011. *Final Report on the Investigation of the Macondo Well Blowout*. s.l.:s.n.

Holand, P. & Hammad, A., 2012. *Reliability of Deepwater Subsea BOP Systems and Well Kicks*, Trondheim: ExproSoft.

IEC 60050-191, 1990. *International Electrotechnical Vocabulary - Chapter 191 - Dependability*, Geneva: International Electrotechnical Commission.

ISO 12100:2010, 2010. *Safety of machinery - General principles for design - Risk assessment and risk reduction*, s.l.: s.n.

ISO 13624:1, 2009. *Petroleum and natural gas industries – Drilling and production equipment*, s.l.: s.n.

ISO 61508, 2005. *Functional safety of electrical/electronic/programmable electronic safety-related systems*, s.l.: s.n.

Jacobs, T., 2015. *High-Pressure/High-Temperature BOP Equipment Becoming a Reality*, s.l.: Journal of Petroleum Technology.

Lovie, P., Pappas, J. & Williams, T., 2014. TRLs serve as metric in gauging progress. *EPmag*, Volume September, pp. 17-19.

Lundteigen, M. A., Rausand, M. & Bouwer Utne, I., 2009. Integrating RAMS engineering and management with the safety life cycle of IEC 61508. *Reliability Engineering and System Safety*, pp. 1894-1903.

Murthy, D., Rausand, M. & Trond, Ø., 2008. *Product Reliability. Specification and Performance*. London: Springer.

NACE MR0175, 2009. *Materials for use in H<sub>2</sub>S containing environments in oil and gas*, s.l.: s.n.

National Commission on the BP Deepwater Horizon Oil Spill and Offshore Drilling, 2011. *Macondo. The Gulf Oil Disaster*, s.l.: s.n.

NORSOK D-001, 2012. *Drilling facilities*, s.l.: s.n.

OLF-070, 2004. *Norwegian Oil and Gas Association Application of IEC 61508 and IEC 61511 in the Norwegian Petroleum Industry*, Stavanger: The Norwegian Oil Industry Association.

SINTEF, NTNU, DNV, 2015. *OREDA handbook, 6th edition*, s.l.: Det Norske Veritas.

SINTEF, 2011. *Barriers to prevent and limit acute releases in sea*, Trondheim: s.n.

Strand, G. O. & Lundteigen, M. A., 2015. *Risk controll in the well drilling phase: BOP system reliability assesment*. s.l.:s.n.

U.S. Chemical Safety and Hazard Investigation Board, 2014. *Investigation report. Volume 2. Explosion and fire at the Macondo well*, s.l.: U.S. Chemical Safety and Hazard Investigation Board.

Wang, Y., Yam, R. C. M., Zuo, M. J. & Tse, P., 2001. A comprehensive reliability allocation method for design of CNC lathes. *Reliability Engineering and System Safety*, p. 247–252.

West Engineering Services Inc., 2002. *Mini shear study*, s.l.: s.n.

Wikström, P., Terens, L. A. & Kobi, H., 2000. *Reliability, Availability, and Maintainability of High-Power Variable-Speed Drive Systems*, s.l.: IEEE.

Yang, G., 2007. *Life cycle reliability engineering*. Hoboken, NJ: John Wiley & Sons, Inc..