



NTNU – Trondheim
Norwegian University of
Science and Technology

CEMENTING THE 20 INCHES SURFACE CASING

Carlos Buinga Tembo

Petroleum Engineering

Submission date: October 2014

Supervisor: Pål Skalle, IPT

Norwegian University of Science and Technology
Department of Petroleum Engineering and Applied Geophysics



NTNU – Trondheim
Norwegian University of
Science and Technology

**Department of Petroleum Engineering and Applied
Geophysics**

**CEMENTING THE 20 INCHES SURFACE
CASING**

Carlos Buinga Tembo

**Department of Petroleum Engineering and Applied
Geophysics**

MSc THESIS IN PETROLEUM ENGINEERING

CEMENTING THE 20 INCHES SURFACE CASING

By

Carlos Buinga Tembo

Supervisor: Pål Skalle

Co-Supervisor: Juan E Munoz

ACKNOWLEDGEMENTS

I would like to express my deep gratitude and appreciation to my supervising professor Pål Skalle, my Maersk Oil Houston co-supervisor Engineer Juan E Munoz, and Edmond Merdy for their valuable advice and guidance with their knowledge, wisdom, experience and beneficial comments.

Special gratitude is expressed to Maersk Oil for sponsoring my thesis in Houston.

My thanks are to Halliburton and Baker Hughes for their support.

Also I'd like to thank Lee Paul Milligan and Lars Espen Bjørgum for their encouragement and support, to Dr. Mayembe, Pedro Onde, and Paulina Capita for their advice.

I wholeheartedly appreciate my parents: Isidoro Tembo and Rosalina Pado, and my brothers and sisters namely Teresa Bazunga, Jose Nduli, Madalena Z. Tembo, Beatriz Tembo, João Aleixo Tembo, Eduardo Tembo, Felicidade Tembo, and Paulo Tembo for their love.

Finally I thank my Lord, Jesus Christ, for all He has done for me.

ABSTRACT

The placement of cement in annulus behind the casing is a important operation in an oil well's life. To ensure zonal isolation, the fluid in place in the annulus has to be completely displaced by the slurry. Poor excess volume calculations and displacements in deepwater surface casing may compromise the integrity of the well since the surface casing provides structural support of the subsea BOP. In a weak or depleted formation, conventional cement is not a solution because the bottomhole circulating pressure (BHCP), (not necessary at bottom) may exceed the rock strength, open fractures in the rock, and portion of the cement is lost to the formation. Therefore, to avoid losing cement to the formation, the cement slurry density must be reduced to a level where the hydrostatic pressure and the frictional forces are less than that of the fracture gradient. This can be done in three ways: The addition of water (water extended), the addition of nitrogen (foam), or addition of lightweight microspheres (LMS). All these slurry density reduction methods will result in lightweight cement which could sometimes provide the best overall solution.

Water-extended cement: Simply adding extra water (and necessary water-extending additives that will tie-up the extra water) to cement slurry can reduce the density sufficiently to allow the cement slurry to be safely circulated and the desired top of cement (TOC) reached (preferably seabed)

The primary advantage of this class of slurry is economics. Typically only a small amount s of water- extending material are required to tie up large amounts of water. Thus, the real benefit of these systems, in addition to the decrease in density, is the increase in the slurry yield per sack. As more water is added, less cement (and associated additives) needs to be used.

However, as additional water is added above the standard «four to six gallons» per sack, the cement becomes more diluted, compressive strength declines, and permeability increases. As the density decrease approaches 10,5 to 11 ppg (pound per gallon), the dilution effect becomes so great and compressive strength development so slow to the point, it may no longer be a good annular sealant.

To avoid several problems such as non returns of cement to the surface encountered by Maersk Oil Angola in Chissonga Project, the use of foam cement is appropriate. With injection of nitrogen, the volume increases and the cement slurry density is adjusted easily.

ACRONYM LIST

ASME	American Society of Mechanical Engineers
API	American Petroleum Institute
ASCII	American Standard Code for Information Interchange
BOP	Blowout Preventer
BHCP	Bottom hole Circulating Pressure
BHA	Bottom hole Assembly
BVO	Ball Valve Operator
BBL	Barrel
BPM	Barrels per Minute
CHS	Chissonga
CART	Cam-Actuated Running Tool
DCD	Declaration of Commercial Discovery
DP	Drill Pipe
ECD	Equivalent Circulating Density
EMW	Equivalent Mud Weight
HP WHH	High Pressure Wellhead Housing
HSE	Health, Safety and Environment
ID	Inner Diameter
ISO	International Organization for Standardization
KOP	Kick off plug
LMS	Lightweight Microspheres
LOT	Leak-off Test
LW	Lightweight
LCM	Lost Circulation Material
LPWH	Low Pressure Wellhead Housing
LAS	Log ASCII Standard
MD	Measured Depth
MOA	Maersk Oil Angola
OD	Outer Diameter
OOH	Occupational Outlook Handbook
OH	Open Hole
POOH/POH	Pull Out of Hole
PPF	Pound Per Foot
PPG	Pound per Gallon
PSA	Production Sharing Agreement
PV	Plastic Viscosity
POB	Personnel on Board
RIH	Run in Hole
ROV	Remotely Operated Vehicle
SG	Specific Gravity
TD	Total Depth
TDS	Top Drive System
TOC	Top of Cement
TLWP	Tension Leg Wellhead Platform
UCA	Ultrasonic Cement Analyzer
VDL	Variable Density Log
YP	Yield Point

NOMENCLATURE

Symbol	Definition
m_s	Mass of surfactant
m_{ubws}	Mass of unfoamed base Cement Slurry with surfactants
m_{ubwos}	Mass of unfoamed base Cement slurry without surfactants
m_a	Mass of the Sample in air
m_{sw}	Mass of the Sample in water
m_w	Mass of water
m_c	Mass of cement
Q_{foam}	Foam quality
v_{gas}	Volume of gas
v_{foam}	Volume of foamed Slurry
v_{bc}	Blending Container Volume
w_s	Mass fraction of surfactant
w_c	Mass fraction of cement
φ_g	Volume fraction of gas
w_w	Mass fraction of water
ρ_s	Density of the Sample
ρ_{fc}	Foamed Cement slurry density
ρ_c	Density of cement
ρ_w	Density of water
ρ_{bwos}	Density of the base cement slurry without surfactant

CONTENTS

ACKNOWLEDGEMENTS ii

ABSTRACT iii

ACRONYM LIST iv

NOMENCLATURE v

INTRODUCTION..... 1

1. PROBLEMS OF DISPLACEMENT WHILE CEMENTING 20" SURFACE CASING
..... 3

2. CASING AND OILFIELD CEMENTING 4

2.1 Casing 4

 2.1.1 Introduction..... 4

 2.1.2 Purpose of Surface Casing for Deepwater Applications..... 5

 2.1.3 Types of casing used in Deepwater Angola..... 6

 2.1.4 Surface casing equipment for Deepwater Operations..... 7

2.2 Oilfield cementing..... 9

 2.2.1 Conventional cementing design 9

 2.2.1.3 Cement mixing and pumping equipment 11

3. CHISSONGA PROJECT 13

3.1 Location and Reservoir Characteristics..... 13

 3.1.1 Location 13

 3.1.2 Reservoir characteristics 14

3.2 Chissonga Project. Surface Casing running and Cementing Procedure 15

 3.2.1 Run 20" Casing with HP WHH 15

 3.2.2 Cement 20" Casing 21

3.3 Foam cement	27
3.3.1 Foam stability and structure	29
3.3.2 Foamed cement properties	31
3.3.3 Preparation and testing of foamed cement slurries at atmospheric pressure	32
4. FOAM CEMENT IN ANGOLAN OILFIELDS	45
4.1 Chissonga Development Project-Block 16.	45
4.3 Cement calculations	50
5. SIMULATION OF CEMENTING 20" SURFACE CASING IN DEEP WATER OF ANGOLA	54
5.1 Lightweight Lead & Tail. Offshore	54
5.1.1 Job Design.....	54
5.2 Discussion	75
6. CONCLUSION.....	76
REFERENCES	77
APPENDIX A	78
APPENDIX B.....	89

This page was intentionally left blank

Cementing the 20 inches surface casing

INTRODUCTION

The cementing process of oil and gas wells in Angola has grown in complexity; due to the nature of deepwater drilling cementing operations require more specialized techniques. Several solutions have been developed by operators and pumping services companies such as new cement slurries, centralization and testing requirements.

In some Angolan deepwater fields the successful isolation of shallow drilled-through formations below the 20" surface casing is obtained by preventing the migration of gas and fluid vertically through the 13 3/8" casing annulus, and in this way stopping fluid migration between neighboring formations, and thus limiting their environmental damage impact.

The 20" surface casing also provides well structural integrity to the subsea wellhead and prevents further erosion of the wellbore. It provides also protective housing through the completion of drilling operations.

When cementing the 20" surface casing the cement slurry shall fill the annular space between the wellbore and the casing to provide the support of the subsea blowout preventer (BOP) and further casing hangers. The quality of the cement job is the key to determining the long integrity of the upper part of the well.

The main inconvenience is having a relatively large annulus, since the 26" hole is drilled with seawater in unconsolidated, soft or sandy formations. The turbulent flow generated while drilling causes the hole to enlarge and increase the excess of cement required.

The surface casing cementing is an actual problem in Angola and elsewhere. This requires the use of generally expensive lightweight slurries, which involve logistical and operational problems. In the future several deepwater projects will require tension leg wellhead platform (TLWP); these facilities do not have enough store capacity for the required volume of cement and are also limited in deckload capacity. Proper surface casing cementing is also critical for the TLWP's since the conductors and surface casing are seven meters apart at seabed and any potential loss of returns to the formations will compromise neighboring wells.

Maersk Oil during exploration had issues on the 20" surface casing cementing in following wells:

Chissonga-1	No returns during 20" jobs.
Caiundo-1	Losses Partial returns.
Chissonga-2	No returns during 20" jobs.
Chissonga-3	Losses Partial returns.

Cementing the 20 inches surface casing

Caporolo-1	Losses while cementing 20”.
Chissonga-4	Partial returns, losses during leak-off test (LOT) shoe squeezed.
Catumbela-1	String dropped five meters while pumping lightweight (LW), etc.

The objective of this thesis is to improve the cement design and operations by analyzing Foam cement slurries as a solution that will allow Maersk Oil Angola (MOA) to assure cement returns to surface and maintain the integrity of the TLWP neighboring wells.

1. PROBLEMS OF DISPLACEMENT WHILE CEMENTING 20" SURFACE CASING

Surface casing serves to case off relatively shallow unconsolidated formations and aquifers. In addition to maintaining hole integrity, the surface casing prevents the contamination of fresh groundwater by drilling fluids, subterranean brines, oil or gas. Depending on the country, there are usually government regulations stipulating minimum casing requirements and set-cement properties, particularly regarding the protection of aquifers.

A major problem associated with cement surface casing is placing the required annular height of cement slurry (often to surface) when the hydrostatic pressure of the slurries exceeds the formation fracture pressure or passing permeable zones.

The use of low-density slurries and foamed cement slurries is becoming more common in such circumstances.

Washouts are another frequent problem. When the borehole has enlarged washouts, its size often exceeds the measuring capacity of caliper tools.

Cementing of surface casings traditionally has been performed in stages when severe lost-circulation zones or other troublesome intervals were encountered. Today, they are frequently cemented in a single-stage operation using high-performance, low-density cement systems. Surface casing often encounters sloughing shale and shallow gas pockets as well as shallow water influx. These are among some of the most difficult casings to cement successfully. Low formation temperatures prolong the thickening time of conventionally extended cement slurries, and the large annular cross-sectional area often prevents achieving the flow properties required to ensure efficient mud removal. High-solids, high-performance lightweight cements, which combine fast setting characteristics and high viscosity at low density, are useful in deepwater wells.

Large-diameter casings, with ODs equal to or greater than 18-5/8", in this case 20", are subject to large upward forces during cementing. Such casings have a large cross-sectional area upon which the pumping pressure can act. With no preventive measures, the upward forces may exceed the buoyed weight of the casing, resulting in casing rising out of the hole. To prevent such problems, the pump pressure can be controlled, the density of the mud used to displace the slurry can be adjusted.

2. CASING AND OILFIELD CEMENTING

2.1 Casing

2.1.1 Introduction

It is generally not possible to drill a well through all of the formations from surface (or the seabed) to the target depth in one hole-size section. For instance, fresh-water-bearing zones (usually found only near the surface) must be protected soon after being penetrated. The well is therefore drilled in sections, with each section of the well being sealed off by lining the inside of the borehole with steel pipe, known as casing, and filling the annular space or at least the lower portion between this casing and the borehole wall with cement. Then drilling commences on the subsequent hole section, necessarily with a smaller bit diameter that will pass through the newly installed casing.

Casing is one of the most expensive components of an oil well, and failure can be catastrophic. Care must be taken by designing an economic casing program that will meet the requirements of the well. Figure 1 shows an example of deep-water exploration well casing design used by Maersk Oil Angola.

.

Cementing the 20 inches surface casing

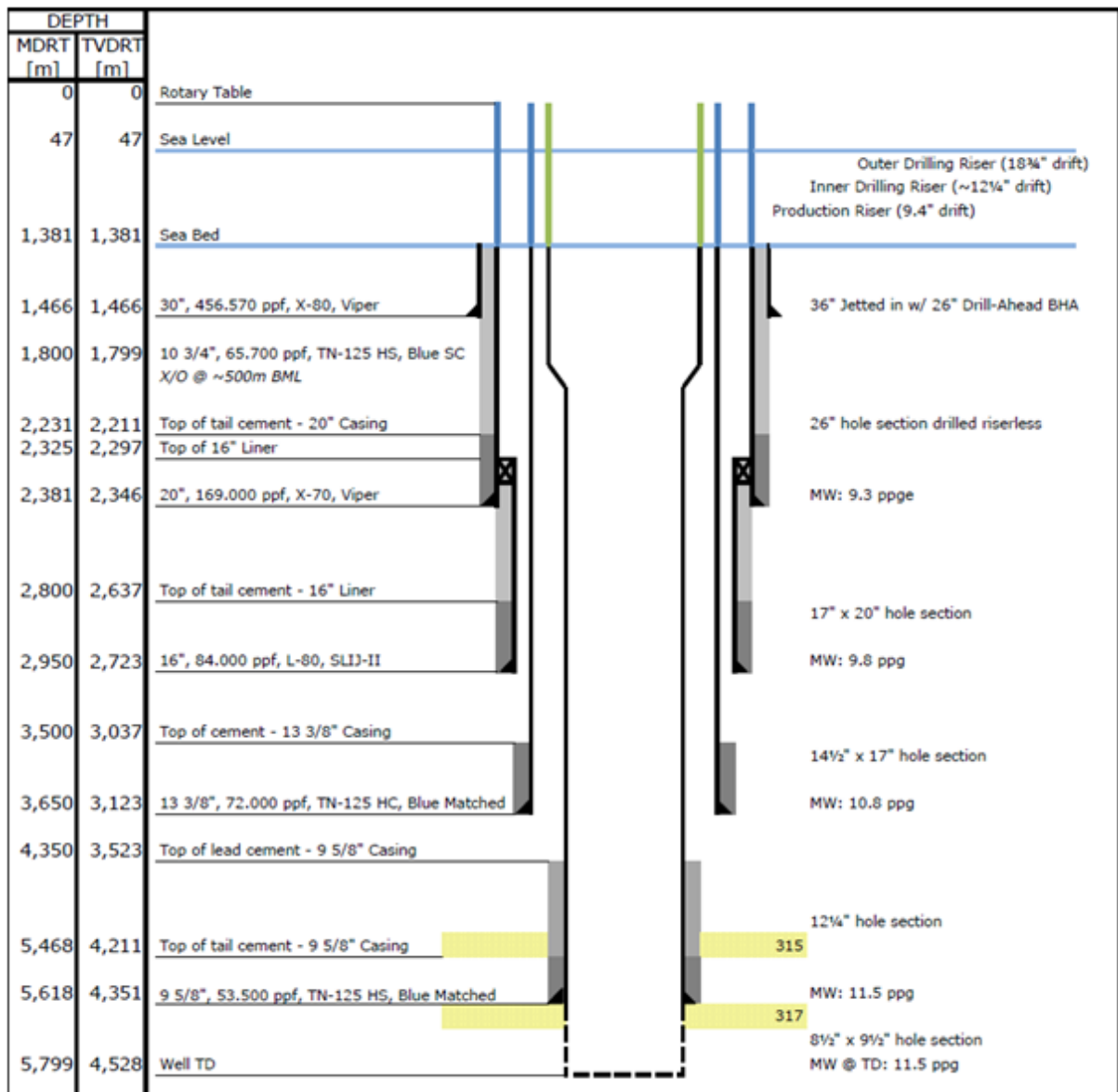

Figure 1: Typical Chissonga Development Well Casing Deepwater Angola.(Maersk Oil)

2.1.2 Purpose of Surface Casing for Deepwater Applications

In deepwater the casing is a large diameter pipe that is assembled and inserted into a recently drilled section after jetting the 36" conductor and disengaging the drill ahead tool of a borehole and typically held into place with cement. Casing that is cemented in place aids the drilling process in a several ways:

- Will give structural integrity of the deepwater well for subsea BOP installation and subsequent casing architecture.
- Minimizes damages of both the subsurface environment by the drilling process and the well by a hostile subsurface environment.

Cementing the 20 inches surface casing

- Provides a high-strength flow conduit for the drilling fluid to the surface and, with the installation of the blowout preventers (BOP) on the HPWH, permits the safe control of formation pressure.
- Prevents collapse of the borehole during drilling and hydraulically isolates the wellbore fluids from the surface formations and formation fluids

2.1.3 Types of casing used in Deepwater Angola

Table 1 below lists the properties of different types of casing:

Table 1 Summary of Casing types (U.S. Gulf Coast)

Casing type	Size OD (in)	Setting depths (m)	Function
Conductor pipe	16-30+	12,192 - 457,2	Protects rig foundation. Restrains unconsolidated formations. Confines circulating fluids. Prevents formation fluid flow and lost circulation. Key structural foundation for the subsea wellhead.
Surface casing	7-18	To 1371,6	Supports BOP's and well head. Provides minimal pressure integrity Prevents contamination of fresh-water zones. Prevents loss of circulation.
Intermediate casing	7-11,75	Varies	Prevents sloughing and hole enlargement during deeper drilling operations. Protects production string from corrosion. Protects hole from high formation pressure. Helps prevent stuck pipe from key-seating. Prevents loss of circulation
Production casing	2,375-9,625	Through production zone	Prevents migration of reservoir fluid. Allows selective production of the oil and gas from reservoir. Protects down hole producing equipment. Helps provide well control if tubing fails.

Cementing the 20 inches surface casing

2.1.4 Surface casing equipment for Deepwater Operations

2.1.4.1 Introduction

Some casing equipment such as floats, plugs, centralizers, and scratchers are mechanical devices commonly used in running pipe and in placing cement around casing. This section provides a description and application of those mechanical aids.

Floating equipment

Floating equipment is used on the lower areas of the casing to reduce derrick stress by allowing the casing to be floated into place.

The guide shoe directs the casing away from ledges and minimizes sidewall caving as the casing passes through deviated sections of the hole.

Floating equipment includes various types of valves and collars to control fluid flow into and out of the string (Figure 2).

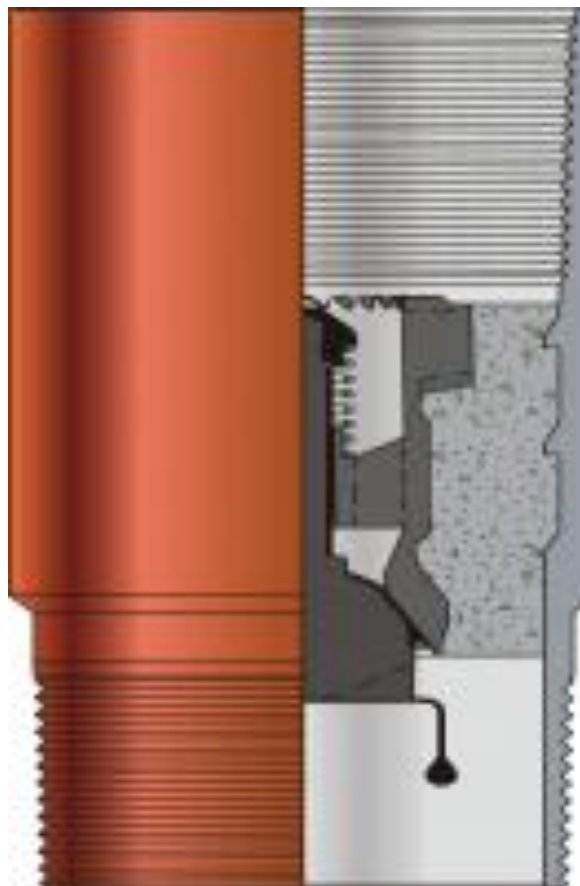

Figure 2: Float collar (Halliburton)

Cementing the 20 inches surface casing

Casing centralizers

Centralizers (Figure 3), prevent drag while pipe is run into the hole, center the casing in the wellbore, minimizes differential sticking event, reduces channeling to aids in mud removal.

Maersk Oil uses Bow Spring Non-Weld Centralizers manufactured by Weatherford.

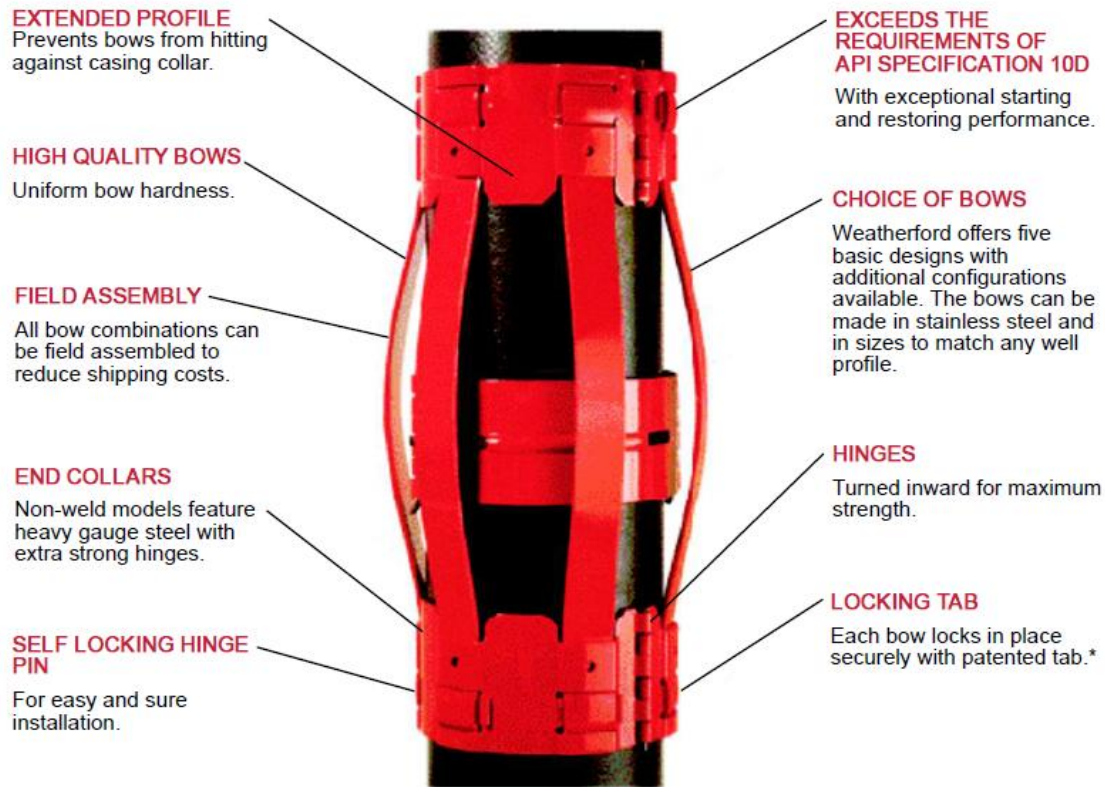

Figure 3: Centralizer STA4NW-STNW-Cen (Bow-type)20*26.(Weatherford)

Description:

Casing size (in): 20"

Bow-type: STA4

Preferred hole size combination (in): 24", 26

Summary of the generic casing schemes of the base case for the Chissonga development well designs.(Table 2)

Cementing the 20 inches surface casing

Table 2 Chissonga Casing Design Summary (Producers)

Hole Section	Casing Size	Casing Designation	Casing Weight	Casing Grade*	Casing Connection*
N/A	36''	Conductor	552ppf	X65	Viper
26''	20''	Surface	169ppf	X56	RL-4S
17 ½''	13 3/8''	Intermediate	72ppf	L80	Tenaris Blue SC
12 ¼''	10 ¾''	Production	65.5ppf	TN110HS	Tenaris Blue
	9 5/8''		53.5ppf	TN110HS	
8 ½''*9 ½''	N/A	Screens			

*Proprietary casing grades and connections displayed satisfy the required load cases.

2.2 Oilfield cementing

2.2.1 Conventional cementing design

2.2.1.1 Introduction

A poor cementing job can result in a failure to isolate zones and can be very costly in the productive life of any well.

In drilling operations cement serves several purposes such as:

- To provide support and protection to the casing
- To enable zonal isolation by preventing the movement of fluids through the annular space outside the casing
- Stops the movement of fluid into fractured formations

2.2.1.2 Well cement

Well cement and construction cement have one thing in common-they are both Portland cements. Their difference lies in the fact that well cement, in addition to its Portland cement base, is mixed with additives in order to tailor it to a particular application and is also manufactured to a higher level of consistency.

Portland cement, invented in 1824 by Joseph Aspdin, is manufactured as a result of a chemical reaction between limestone and clay at temperatures of about 2,600 to 3,000 °F.

Cementing the 20 inches surface casing

There are four principal compounds in Portland cement:

- Tricalcium silicate C_3S ;
- Dicalcium silicate C_2S ;
- Tricalcium aluminate C_3A ;
- Tetracalcium aluminoferrite C_4AL

Portland cement, when set, develops compressive strength due to hydration as a result of reaction between water and these constituting components of the cement. The rate of hydration depends on temperature, size of cement particle and the percentage of each component present, with C_3A hydrating most rapidly followed by C_3S and then by C_4AL and finally by C_2S . This hydration reaction results in reduction of volume which makes Portland cement to shrink when set.

When Portland cement is mixed with water, tricalcium silicate (C_3S) and dicalcium silicate (C_2S) hydrate to form calcium silicate hydrate (C-S-H) gel and hydrated lime ($Ca(OH)_2$). At temperatures higher than 230°F, C-S-H gel converts to α -dicalcium silicate hydrate ($\alpha-C_2SH_2$). Conversion to the $\alpha-C_2SH$ phase results in the loss of compressive strength and any increase in permeability. Conversion of C-S-H gel to $\alpha-C_2SH$ AT 230 °F and higher can be prevented by adding crystalline silica.

The American Petroleum Institute (API) as defined specifications for material and testing for well cement (API Specification 10A), which includes requirements for eight classes of oil-well cement (classes A through H). Table 3 below is a summary of API cement.

Table 3 API Cement classifications [8]

API class	Operating temperatures(°F)	Suitability
A	80-170	Good for 0-6000ft depth. Used when special properties are not required.
B	80-170	Good for 0-6000ft depth. Used for moderate to high sulphate resistance
C	80-170	Good for 0-6000ft depth. Used for moderate to high sulphate resistance and when high early strength is required
D	170-230	Good for 6000-10,000ft depth. Used for moderate to high sulphate resistance and moderately high temperatures and pressures
E	170-290	Good for 10,000-14,000ft depth. Used for moderate to high sulphate resistance and high temperatures and pressures
F	230-320	Good for 10,000-16,000ft depth. Used for moderate to high sulphate resistance and extremely high temperatures and pressures
G	80-200	Good for 0-8,000ft depth. Used for moderate to high sulphate resistance. Has improved slurry acceleration and retardation.
H	80-200	Same as class G

In the Gulf of Mexico is normal to use class H cement for the surface casing. In Angola this class H is not available and the class G cement is regularly used for cementing the surface.

2.2.1.3 Cement mixing and pumping equipment

Figure 4 summarizes the preparation of a cement slurry. At the location, the cementing contractors (Halliburton, Dowell-Schlumberger another company) usually provides all the surfaces equipment needed to perform any kind of primary or secondary cementing. The jobs may be pre-defined by the well plan (cementing of casing, plugs for hole abandonment) or done on an as-needed basis (plugging back for a sidetrack, cement squeezes to control lost circulation). Typically, the equipment package provided by the contractor includes:

- Storage tanks for bulk products or storage containers for sacked products;
- A skid- or trailer-mounted cementing unit, incorporating a mixer, manifold, one or two section slurry tank (for measurement and transfer of produced slurry), one or more plunger-type cement pumps, diesel or electric power supply and control equipment;

Cementing the 20 inches surface casing

- Modular piping and connecting hardware, to allow a variety of connection options between cement unit and rig circulating system, as required by the type of cement job;
- Raw materials storage and blending cement mixing and cement pumps all working together.

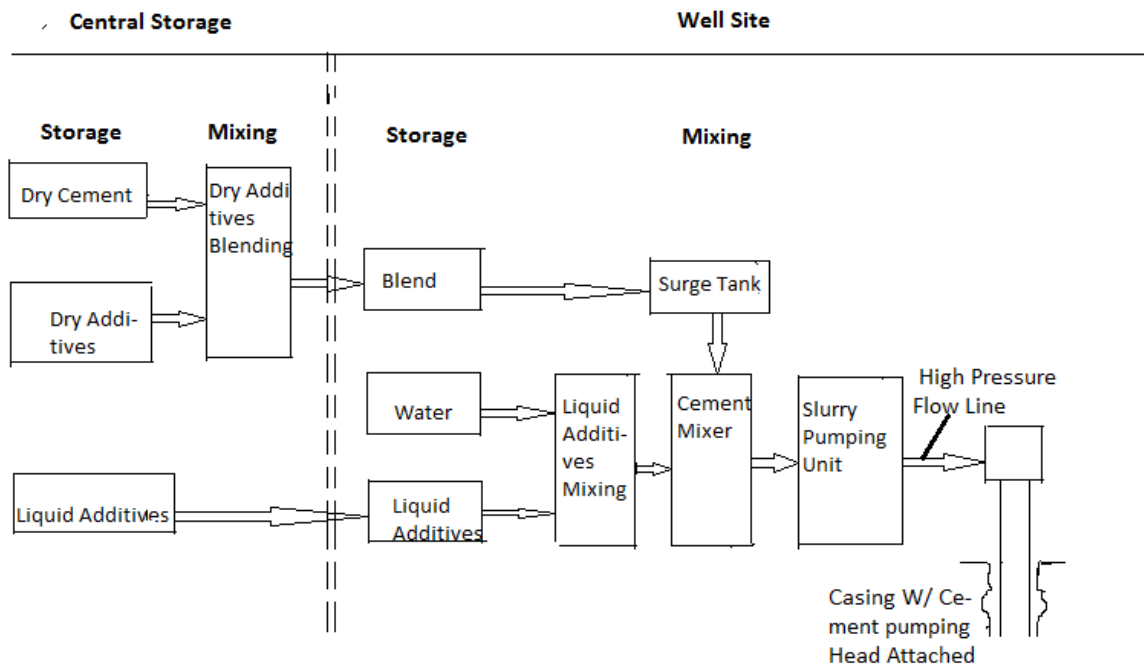

Figure 4: Typical oil well cement mixing process (Halliburton)

2.2.1.4 Cement additives

Depending on downhole conditions, cement used in completing the well requires specific qualities. Additives, when added to the Portland cement base, could be used to achieve the desired qualities. They could also be to extend the properties of the base cement.

Some of the most commonly additives used in oilfield cementing include:

- Accelerators
- Retarders
- Weight Agents
- Fluid Loss Control
- Extenders
- Strength enhancers

Cementing the 20 inches surface casing

3.1.2 Reservoir characteristics

All reservoirs are Oligocene in age and are characterized as channelized turbidite and gravel reservoirs in combining stratigraphic/structural traps (Figure 6). The axes of the channels are characterized by thicker-bedded sands, with thin sand stringers extending into the channel margins.

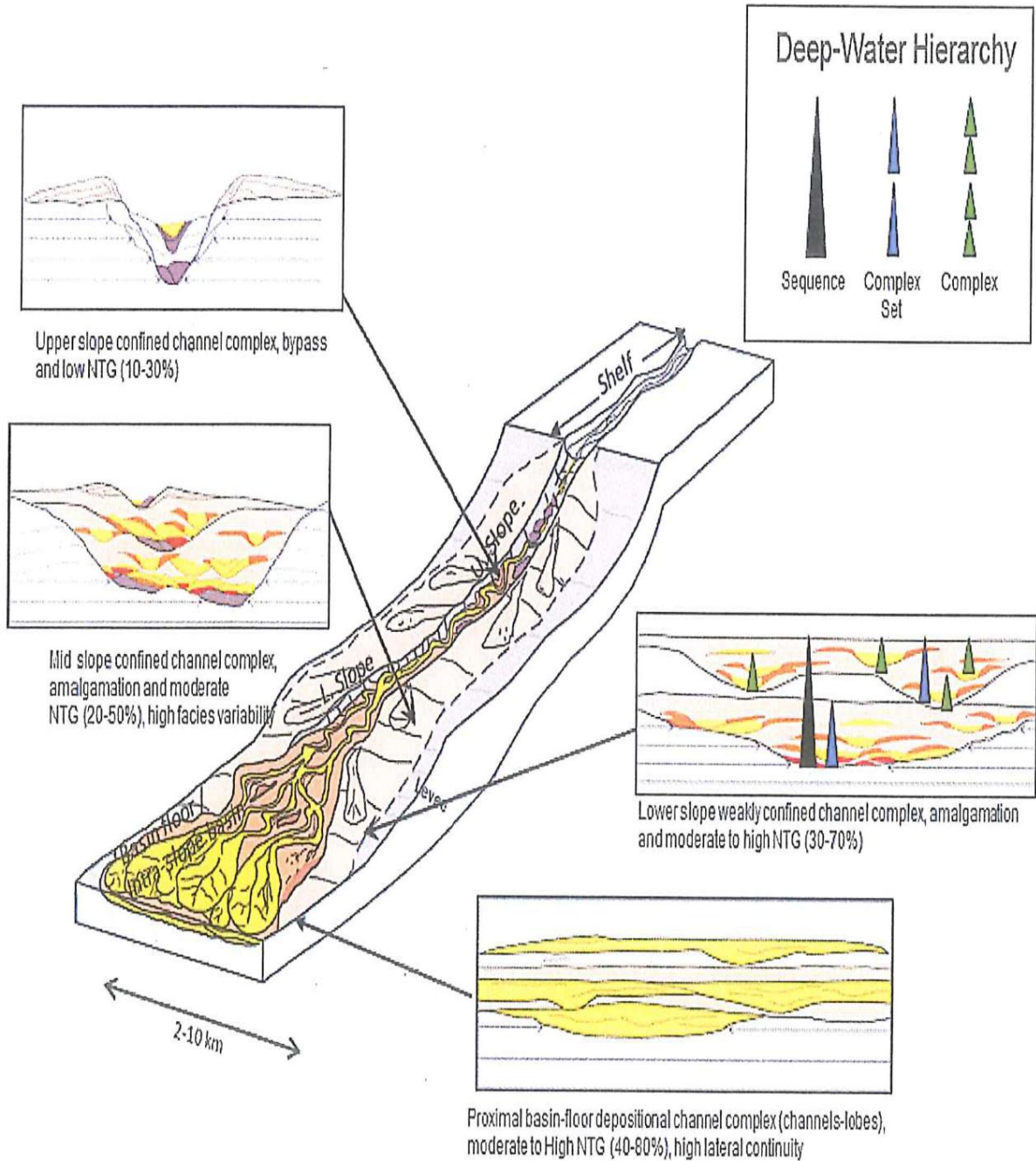

Figure 6: Characteristic deep-water reservoir styles (slop-to-basin profile)

Cementing the 20 inches surface casing

The Chissonga field do not have potential risks of shallow gas and shallow water flows but unconsolidated surface formations make the conductors strength length and surface casing cementing important.

Reservoirs in the Chissonga area interpreted to have been deposited in a middle to lower slop environment and key reservoir styles consist of confined to weakly confined channel systems, leveed channel systems, and ponded to distributive systems.

3.2 Chissonga Project. Surface Casing running and Cementing Procedure

3.2.1 Run 20" Casing with HP WHH

The 20" RL-4S casing will be run vertically to setting depth of +/- 2400 MD. The inner string is spaced out inside the 20" casing and 18 ¾" HP WHH was latched into the 36" or 30" LP WHH.

3.2.1.1 Preparations required

1. Prepare 20" casing and running tally:
 - (a) Inspect and tally all 20" casing joints;
 - (b) Replace any damaged or improperly installed O-ring;
 - (c) Visually check shoe joint for debris;
 - (d) Check that bottom 4 m of 20" casing shoe joint is painted yellow;
 - (e) Check that yellow hoops are painted in 1 m interval on the HP WHH extension joint for first 5 m – measured from the top of the HP WHH.
2. The 20" casing to be run using power tongs, 20" casing bowl, safety clamp and with single joint elevator. 5" 19,5 ppf S135 inner string to be run with C-plate and API bowl.
3. Offline Activities: A MODU that will be used in the Chissonga Development a Dual Derrick rig which allow for a more efficient operation compared to a conventional rig. It is suggested to run 20" casing offline so that 20" casing to be at seabed at the time of POOH 26" BHA from the LP WHH. This is considerably going to reduce the

Cementing the 20 inches surface casing

time in running the 20" casing to section TD and consequently reduce the risks. The 26" BHA can be POOH offline while running 20" casing in hole.

4. Rig up and run 20" 129 ppf X56 RL-4S casing as per section 3.2.1.2
 - (a) Fill shoe joint to ensure draining is possible;
 - (b) Install 1 each 20" × 26" bow spring centralizers will be used on 20" casing on bottom 10 casing joints.
 - (c) Fill each joint of casing with seawater as it is run.
5. Pick up the 18 ¾" HP WHH assembly with back-up 18 ¾" CART previously installed and make up to 20" casing string.
6. Lower the 18 ¾" HP WHH to a workable height and install the two support clamp halves to the wellhead housing OD;
7. Land HP WHH on rotary with support clamp;
8. Release running tool from HP WHH and lay out same;
9. Install C-plate and run 5" drill pipe inner string, spaced out to the minimum 30 m above float shoe;
10. Make up previously racked 18 ¾" CART assembly to inner string, then make up CART to HP WHH;
 - (a) Record weight of inner of string and running tool prior to make up
11. Lower casing on 6 5/8" 47 ppf landing string until below splash zone. Connect TDS & pump slowly until all air is evacuated. Allow to fill with water then close fill-up ball valve.
 - (a) Record buoyed weight of casing plus inner string.
 - (b) Pump to confirm seal integrity
12. Continue RIH 20" casing to seabed and standby until 26" BHA is pulled out;
13. Move rig above wellhead. Stab 20" shoe in wellhead and displace the contents of the string to 11 ppg "displacement mud";

Cementing the 20 inches surface casing

14. Run casing on landing string to just above landing depth. Unlock compensator before landing into LP WHH.
 - (a) Fill drill pipe with 11 ppg “displacement mud” as run.
 - (b) Wash down with” displacement mud” if required. If there is excess. “displacement mud” near the end of the casing run, wash down last stands to deplete the mud.
15. Pick up the cementing stand. Unlock the compensator and land out 18 ¾" HP WHH in 36" LP housing.
 - (a) Prior to land out, circulate with seawater to ensure circulation all around 20" casing;
 - (b) Observe and verify land out with ROV(Figure 7);
 - (C) Record slope indicator readings and final LP WHH stick-up on land out;
 - (d) Adjust compensator to slack off 50kbl in increments of 25kbl while monitoring for subsidence
16. Pull test 50kbl over buoyed weight of casing plus inner string and running string (as recorded in step 9) to confirm latch-in.
17. Maintain 100klb over pull (landing string +inner string) during cementing.



Figure 7: ROV

Cementing the 20 inches surface casing

3.2.1.2 Twenty inches Surface Casing with 20" HP WHH Schematic used in Chissonga Exploration Campaign.

20" Casing w/ 18-3/4" HPWHH				
	Description	Number	Length(m)	Supplier
	Vetco 18-3/4"HPWHH			
	w/18-3/4"HPWHH w/ extension joint 20";0,625WT, X-56	1	4	Vetco
	RL-4S PN			
	RL-4S BOX			
	Intermediate joints 20";0,625WT, X-56	As Required	958	Vetco
	RL-4S PN			
	RL-4S BOX			
	Intermediate joint w/ 16" landing ring 20";0,625"WT, X-56	1	12,35	Vetco
	RL-4S PN			
	RL-4S BOX			
	Intermediate joints 20";0,625WT, X-56	As Required	37,65	Vetco
	RL-4S PN			
	RL-4S BOX			
	Float Shoe joint 20";0,625" WT, X-56	1	12,35	Vetco
	Welded 20" Shoe			Vetco

TOTAL STRING LENGTH (m)	1024
SHOE DEPTH m MD	2400
SEABED m MD	1376

Note: All lengths are approximate and need to be verified prior to run casing.

Chissonga Development Connector Performance.

Since the Chissonga development wells require shallow KOP the directional work will start in the surface hole. The project is considering more robust connectors to cope with the bending of the deviation required . The angle at the 20 in shoe will be 30 degrees.

Figure 8 below shows the Connector Performance Data sheet of a connector currently being considered for the Chissonga Development.

Cementing the 20 inches surface casing

						Connector Type:	ViperTM
						Pipe OD:	20,000 inches
						Pipe Wall Thickness:	0,812 inches
						Pipe Grade:	X-70
						Connector Grade:	GP-95
DIMENSIONS		[1]	Pipe	Connector	Comments		
Outside diameter	(in)		20,000	21,620	External Upset = 0,810 in		
Inside diameter	(in)		18,376	18,250	Internal Upset = 0,063 in		
Drift diameter	(in)	[2]	0,812	18,150			
Wall thickness	(in)			0,812			
PERFORMANCE PROPERTIES			Pipe	Connector Body		Connector Weld Neck	
			Capacity	Capacity	Efficiency	Capacity	Efficiency
Tension yield strength	(kips)	[3,4]	3426	5114	149%	4650	136%
Compression yield strength	(kips)	[5,6]	3426	3308	97%	4650	136%
Bending yield strength	(ft-kips)	[7]	1316	1589	121%	1787	136%
External pressure rating	(psi)	[8]	2820	3150	112%	3240	115%
Internal pressure rating	(psi)	[9]	4970	6270	126%	6750	136%
Maximum allowable deviation	(1/100 ft)	[10]	16,0	19,4	121%	21,8	136%
MATERIAL PROPERTIES			Pipe	Connector			
Material specification			API 5L	XL Systems			
Material grade		[11]	X-70	GP-95			
Minimum yield strength	(psi)		70000	95000			
Minimum ultimate strength	(psi)		82000	105000			
LOOSE CONNECTOR DETAILS			Box	pin			
Loose connector weight	(lbs)		197	181			
Loose connector length	(in)		11,86	11,82			
FIELD SERVICE DATA			PIPE BODY PROPERTIES				
Minimum required make-up torque	(ft-lbs)		47000	Weight per foot (plain end)	[14]	(lb/ft)	166,56
Maximum make-up torque	(ft-lbs)	[12]	53000	Pipe body cross section area		(in ²)	48,95
ViperLock anti-rotation resistance	(ft-lbs)	[13]	60000	Pipe body moment of inertia		(in ⁴)	2257
Length loss on make-up	(in)		6,78				
Length loss on make-up	(ft)		0,565				

Figure 8: Connector Performance Data Sheet.

Notes for Connector Performance Data Sheet

General Note: Viper connectors are produced in two thread geometries. The viper-1ST connector has a single-start thread and make-up in 1,68 turns. The Viper-3ST connector as a triple-start thread and make-up in 0,56 turns. Dimensions and capacities for Viper-1ST and Viper-3ST connectors are the same. Viper-1ST and Viper-3ST connections are not interchangeable and will not thread together.

[1] All dimensions are nominal dimensions unless otherwise noted;

Cementing the 20 inches surface casing

- [2] Drift diameter is not defined for API 5L pipe;
- [3] Performance properties for pipe and connections are based on nominal dimensions and specified minimum material yield strengths;
- [4] The connector weld neck is the area of the connector adjacent to the weld. In most cases this section is machined to nominal pipe OD and ID dimensions. For certain pipe and forging grade combinations the connector weld neck is the controlling capacity. Connector weld neck capacities use the same formulas as those for pipe capacities, substituting forging minimum yield strength and nominal weld neck OD and ID dimensions;
- [5] Connector body tension and compression yield strengths are based on finite element analysis of each connector size in accordance with industry design codes such as ASME, ISO, and API. The strength ratings are the loads which cause through-section yielding in the connector cross-section. Strength ratings have been verified by full-scale physical testing of the product line;
- [6] Pipe compression capacity does not consider buckling. In most casing specifications, the maximum compression load in the string is limited to the load that causes buckling in the pipe, often significantly less than the pipe body compression yield strength.
- [7] Connector body bending yield strength is based on finite element analysis of each connector size in accordance with industry design codes such as ASME, ISO, and API. Strength ratings have been verified by full-scale physical testing of the product line;
- [8] External pressure ratings for the pipe body are tested on API Bulletin 5C3 collapse formulas. The connector body external pressure rating is based on full API Bulletin 5C3 PIPE body collapse pressure for the design pipe size and grade. Connector pressure capacities have been verified by analysis and physical testing. Viper physical tests typically have demonstrated connector seal ability to pressure levels much higher than the rated pressure capacities;
- [9] Internal pressure ratings for the pipe body are based on API Bulletin 5C3 formulas and assume 87,5% minimum wall thickness. The connector body internal pressure rating is based on the API Bulletin 5C3 pressure rating for the design pipe size and grade. Internal pressure ratings have been verified by analysis and physical testing. Viper physical tests

Cementing the 20 inches surface casing

typically have demonstrated connector sealability to pressure levels much higher than the rated pressure capacities;

[10] Maximum allowable deviation for the pipe body is the curvature that causes bending stress to reach the nominal yield stress. The maximum allowable deviation for the connector body is the equivalent pipe body curvature calculated from the connector bending strength rating;

[11] Connector forgings are manufactured to XL Systems material specifications. These standard forging grades are used each with a different minimum yield strength: GP-70 at 70 ksi, GP-95 at 95 ksi, and GP-110 at 110 ksi;

[12] The connector maximum make-up torque value is provided for guidance only. This value is not the same as connector yield torque. Viper connectors can generally tolerate the make-up torque much higher than the listed maximum make-up torque;

[13] The *ViperLock*TM anti-rotation torque resistance is calculated assuming that two ViperLock screws are installed after connector make-up. Divide this value by 2 to determine the torque resistance provided by each ViperLock screw installed. Up to four ViperLock screws can be installed in a standard Viper connector for applications requiring higher resistance to connector back-off. ViperLock capacities are based on analysis and extensive physical testing;

[14] Pipe plain-end weight per foot is calculated per API Specification 5L as $10,69 \times (D - t) \times t$, where D = nominal outside diameter (in) and t = nominal wall thickness (in).

3.2.2 Cement 20" Casing

The 20" casing will be cemented with 10,5ppg Lead slurry and 15,8ppg Tail slurry.

ROV observed for returns to seabed.

Cementing the 20 inches surface casing

3.2.2.1 Hazards

Poor 20" Cement job

In case of poor isolation across geologic formations, the 20" cemented casing could be the only barrier between potential permeable sandy units and the seabed during the well execution. Hence, a successful 20" cement job is very critical. Red dye + coarse mica will be pumped in the spacer and lightweight blend Lead slurry with 200% excess was pumped in OH. The day tanks shall be used to transfer lightweight blend to surge tanks during that job. If deemed necessary, a specialized technician could be mobilized.

3.2.2.2 Preparations

Cementing Summary

The preliminary cement slurry design and recipe below, the final design was provided prior to the cementing job based on the samples from the rig.

20" Surface Casing Cement job	
Cementation Method:	Inner string - 5" DP (not stab-in the shoe)
Cement Slurry:	Lead: Lightweight 10,5ppg Tail: 15,8ppg Class G
Excess Cement:	Lead: 200% in OH Tail: 0% in OH
Cement Additives:	Refer to BJ cementing summary
Spacer Design:	100bbl seawater + red dye + coarse Mica
TOC:	Lead: seabed Tail: 220m above 20" shoe
Displacement fluid:	Seawater

Cement Recipe and Pumping Schedule

Additive	Lead Slurry (gal/bbl)	Tail Slurry (gal/bbl)
Foam Preventer (FP-21L)	0,020	0,020
Cement Dispersant (CD-33L)	0,100	-
Fluid Loss Control (FL-66L)	0,150	-
Retarder (R-21LSG)	0,070	-

Cementing the 20 inches surface casing

Slurry Type	Unit	Lead Slurry	Tail Slurry
Cement Class and Type		G + LW-7/6+BA-90	Neat "G"
Water Type		Seawater	Seawater
Density	ppg	10,50	15,80
Yield	cft/sk	2,546	1,175
Total Mix Fluid	gal/sk	8,602	5,258
Excess	%	200%	0
Cement volume/length	Bbl/m	2083/804	211/220
Spacer Volume and Type	bbl	100 bbl/MCS-5 <i>Spacer</i> TM w/Loss Material	

Pumping Schedule	Volume		Rate		Time
	<i>m</i> ³	bbl	lpm	bpm	min
BJ Pump Space Ahead	15,9	100	954	6	16,7
BJ Pump Lead Slurry	331,2	2083	954	6	347,2
BJ Pump Tail Slurry	33,5	211	795	5	42,2
Drop Foam Ball					10,0
BJ Displace	27,5	173	954	6	28,9
BJ Displace	2,7	17	954	2	8,4
Net time including 120 min as safety time					453,3 min (9h:33 min)

3.2.2.3 Procedures

1. Break circulation with seawater;
2. Pump spacer;
 - (a) Collect a sample of spacer prior to pumping;
3. Mix and pump lead slurry (as per final lab design and simulations);
 - (a) Collect Samples of dry cement and all additives prior to the job;
 - (b) Collect Samples of the cement slurry at the cement unit during the job;
 - (c) Collect a mix water samples prior to the job;
 - (d) Collect a dry cement sample at the end of the job.

Cementing the 20 inches surface casing

4. Mix and pump tail slurry (as per final lab design and simulations).
 - (a) Collect Sample of dry cement and all additives prior to the job;
 - (b) Collect Samples of the cement slurry at the cement unit during the job.

Cement Samples to be stored in mud lab refrigerator.
5. Displace cement with seawater via cementing unit to place top of cement 15 m above 20" shoe.
 - (a) Do not over displace;
 - (b) Observe returns at seafloor, with ROV, and not if/when cement reaches the mudline. Use Ph meter in ROV (if available);
 - (c) Note: In case the mud pumps have to be used, then check volumes and efficiency accurately by transferring mud or seawater between two mud pits of known volume
6. Release pressure and verify that floats are holding.
 - (a) Note: If floats do not hold, pump back volume returned. Hold pressure and wait time indicated in the UCA tests to reach 50-100 psi compressive strength. Check surface samples in refrigerator to confirm.
7. Confirm no movement of 36" conductor and confirm with MOA Drilling superintendent prior to releasing the running tool.
8. Confirm neutral weight at running tool and release running tool with five (5) right-hand turns (as per Vetco instructions).
9. POOH with running tool and inner string. Drop 7" foam ball and pump to clear cement stringer.
 - (a) Space out landing string to be able to pick up clear of HP housing in one motion (i.e. minimize potential to nick or damage VX/VT gasket profile).
10. ROV to close the six ball valves on the 36" LP housing.
11. ROV to run portable bull's-eyes to check 18 3/4" HP housing inclinat

Cementing the 20 inches surface casing

Problems of non-returns in Chissonga project

Maersk Oil Angola during cementing 20 inch casing has found among many problems summarized in the table below, the non-returns of the cement to the surface; because of this issue foamed slurries are considered as an option to address in order to minimize losses and getting back cement to the seabed during the cementing operations in Chissonga project.

Well Name	Well Control	Losses	Other
Chissonga-1		<p>1) No returns during 20" cement job 12 ppg LITEFIL lead).</p> <p>2) Drilled 17.5" to 2853 mMD, ran wireline logs, RIH for wiper trip (10,2 ppg mud), 30-40 bph losses at 2286 m. LCM ineffective, cement plug spotted/squeezed at 20" shoe effective.</p> <p>3) Losses running and circulating 13,375" casing. No returns during cement job.</p>	<p>Unable to set 11,75" liner hanger, running tool released unexpectedly and string dropped 3 m-string dogs above liner top. Re-ran modified inner string to cement. Tie-back packer run.</p>
Caindo-1		<p>1) Partial returns during 20" cement job (12 ppg LITEFIL lead).</p> <p>2) Drilled 17,5" to 2663mMD w/10,4 ppg (10,6 ppg ECD), 15 bph losses while POO, spotted LCM pills called section TD.</p> <p>3) No returns circulating before 13,375" cement job.</p>	<p>Couldn't set 11-3/4" liner hanger and packer, ran/set back-up liner top packer.</p>
Catumbela-1		<p>No returns running 20" casing, partial returns broaching seabed 8 m to wellhead. Partial returns during cement job (11,5 ppg LITEFIL lead)</p>	<p>With 70 m conductor penetration and with 20" run the wellhead subsided the re-jetted another string of 36" (81 m penetration). No issues.</p>
	<p>CHS-2 50 bbl influx w/11,2 ppg mud while RIH w/pipe conveyed logs. Killed by bullheading 120 bbl crude oil-</p>	<p>CHS-2 1) No returns during 20" cement job (11,5 ppg LITEFIL lead) 2) Drilled 17,5" to 2387mMD with 9,7 ppg mud, 21 bph static losses. O/Ps and packoffs when POH. Losses increased to 130 bph at</p>	<p>CHS-2 During repeated attempts to set 11,75" liner hanger inadvertently set liner hanger packer. Shoe cement squeeze was performed.</p>

Cementing the 20 inches surface casing

Chissonga-2	<p>contaminated mud and 1340 bbl 11,6 ppg kill mud. Hole pack-offs after kill. CHS-2ST2 Swabbed influx while POH w/ pipe-conveyed logging string at 3803 m (through POH at reduced rate). 7,5 bbl influx while RIH w/ 3,5" stringer above BOP, closed BSRs. 6 bbl influx after re-opening BSRs. Stripped in to 1792m, 263 bbl gained per stand. Bullheaded 1077 bbl 11,8 ppg mud. Displaced riser to 14,2 ppg. Stripped in to TD circulating 11,8 ppg kill mud. Well dead.</p>	<p>2437 m. Losses cured w/ 100 bl 60 ppb LCM pill spotted in OH. Drilled ahead to 2658 m for casing pointed. Losses potentially due to major unconformity in the Miocene. 3) Losses running, circulating and cementing 13,375" casing. 4) Losses during 8,5" wiper trip at 4563 m, cured w/ 100 bbl LCM pill. CHS-2ST1 No returns during 9,625" cement job. CHS-2ST2 20 bbl losses during 7" liner cement job.</p>	
Chissonga-3		<p>1) Reduced returns after 125 bbl displaced on 20" cement job (10,5 ppg LITEFIL lead) 2) 2bph seepage losses in 12,25" hole at 3886 m spotted 50 ppg CaCO_3 and cured.</p>	
Caporolo-1		<p>1) Losses running, circulating and cementing 20" casing (10,5 ppg LITEFIL lead). 2) In 17,5; 100 bph losses at 2843 m; 10,4 ppg mud, ECD at 10,8 ppg. Picked up to circulating hole clean and reduce ECD, losses up to 1200 bph at 880 gpm. Pumped 8 ppb</p>	

Cementing the 20 inches surface casing

		LCM, losses stopped. Well ballooning from 2843 m to 2868 m (section TD) 3) Losses while running 13,375" (2 bbl/ft). No losses on circ or cement job.	
Chissonga-4		1) Partial returns during 20" cement job (10,5 ppg LITEFIL lead). Losses incurred after performing LOT at 20" shoe. Shoe squeeze required to achieve desired integrity (original LOT: 9,62 ppg EMW). 2) Heavy losses (<100bbl/h dynamic) encountered throughout 12-1/4" pilot hole section	

3.3 Foam cement

Conventional cement not always provides good results when cementing the surface casing. Sometimes problems like non returns during cement jobs are encountered, and to solve this problem drilling engineers are recommending foam cement for the 20" surface casing. Foamed cement is used in well construction situations where low density cement slurry and minimum compressive strength development are required in the cement job design, particularly in shallow hazards mitigation and to increase the chances of a successful surface casing cementing, having cement returns to mudline.

Foamed cement are mixing combination of a base cement slurry, a gas (usually nitrogen), a foaming surfactant, and other materials to provide foam stability. The base cement slurry is usually a conventional G cement system. Therefore, the foam density is adjusted by varying the nitrogen concentration. Although foamed cement was first used by the construction industry more than 60 years ago, its first application in well cementing occurred in 1979. Foamed cementing technology has been evolving ever since.

Foamed cements are generally less expensive than systems containing glass microspheres (Edmondson and Bengel,1983), however, special equipment is required at the wellsite to inject nitrogen or air into the base slurry which bring the cost up.

Foamed cement has several advantages in addition to its low density:

- Relatively high compressive strength developed in a reasonable time

Cementing the 20 inches surface casing

- Less damaging to water-sensitive formations (Bozich et al, 1984; Bour and Vennes,1989)
- Lower chance of annular gas flow (Tinsley et al,1980; Hartog et al, 1983)
- Ability to cement past zones experiencing total losses
- Less bulk capacity required to handle the necessary excess to ensure returns to the mud line
- Maintains hydrostatic pressures during cement gelation.

Also, because the gas little effect on placement properties such as thickening time, the density can be adjusted during the cement job by changing the gas concentration.

Non returns are mainly linked to density and excess used. Table 4 shows the pro and cons of foamed cement and table 5 summarizes the pro and cons of foamed cement compared to lightweight cement.

Table 4 Pro/Cons of foamed cement

Pro	Cons
<ul style="list-style-type: none"> •Is lightweight •Provides excellent strength-to-density ratio •Is ductile •Enhances mud removal •Expands •Helps prevent gas migration •Improves zonal isolation •Imparts fluid-loss control •Is applicable for squeezing and plugging •Insulates •Stabilizes a at high temperatures •Is compatible with non-Portland cements •Simplifies logistics •Enhances volume •Has low permeability •Is stable to cross flows •Forms a synergistic effect with some additives, which enhances the property of the additive. 	<p>The disadvantage of foamed cement is the need for specialized cementing equipment both for field application and for laboratory testing.</p>

Cementing the 20 inches surface casing

Table 5 Pro/Cons of foamed cement and lightweight blend cement. (Maersk Oil)

Option	Pro	Cons
Foam Cement	<ul style="list-style-type: none"> • Only G Cement used(no lost space & silo's cleaning after the cement job) • Less silos • Cement job less costly • Use of LAS 	<ul style="list-style-type: none"> • Higher VDL (0-150 MT depending on silo's capacity) • Higher slurry density (+0,9 ppg) so less chance of return at the sea bead • Equipment rig-up, deck space • Any cement excess stored in day tanks will be increasing VDL compared to lightweight blended cement • Logistic Timing important due to natural loss of nitrogen with time • POB: +/- 8 people required for the job • Quite a lot of equipment involved and failure is more problematic than if performing a lightweight slurry • HSE issue due to Liquid Nitrogen
Lightweight Blend Cement	<ul style="list-style-type: none"> • Lower VDL (0-150 MT depending on silo's capacity) • Lower slurry density (10,50 ppg) • Familiar type of cement job • Any excess of cement in the day tanks is better if VDL control is problematic due to its lighter bulk density • Reduced risk of failure due to less equipment involved 	<ul style="list-style-type: none"> • More silos needed • In general needed mud pit for mixing water due to lack of confidence of most of the cement contractors to use LAS Mud volume space taken, more risks of contamination • Logistic: More volume of cement to be loaded/off loaded, more subject to contamination, blend always less stable than pure G cement(segregation of particles)
HSE Impact	<p>Foam Cementing involves working with Nitrogen. Special care must be taken.</p> <p>In Angola, people have little experience of foam cementing. So training will need to be instigated either in the country or abroad.</p>	

3.3.1 Foam stability and structure

The stability of foamed cement is affected by the foaming agent, the quality of gas, the chemical and physical composition of the slurry, thermodynamic factors, and the mixing methods and conditions. Stable foams exhibit spherical, discrete, disconnected pore structures with a clearly defined cement matrix. Unstable foams have nonspherical and interconnected pores, caused by the rupture and coalescence of gas bubble. Such unstable

Cementing the 20 inches surface casing

foams have a sponge-like structure and develop lower compressive strength, higher permeability, and inferior bonding properties.

Foams are categorized by their quality (Q_{foam}), or the ratio of the volume occupied by the gas to the total volume of the foam slurry (expressed as a percentage). See equation (1) below:

$$Q_{foam} = \frac{V_{gas}}{V_{foam}} \times 100 \quad (1)$$

Where:

Q_{foam} Foam quality

V_{gas} Volume of gas

V_{foam} Volume of foamed slurry

Foamed cement is a compressible fluid; consequently, owing to hydrostatic-pressure variations, the foam quality, and the density, changes as the foam circulates in the well. Q_{foam} decreases and density increases as the foam moves from the surface to the bottom of the casing. As the foam moves back up the annulus, Q_{foam} increases and density decreases. The density can be predicted as a first approximation by considering the compressibility laws and the solubility of nitrogen in the base slurry.

Foamed cement is a three-phase system (gas/liquid/solid), with many phenomena occurring at the interfaces. This system is in constant evolution because of the reorganization of gas bubbles that may grow, shrink, or coalesce, and because of the chemical reactions that occur in the base cement slurry. Foamed cements made under large-scale field conditions, with high shear rates and high pressure, have been found to be more stable than foamed cements made under laboratory conditions (Davies et al, 1981).

The most common method to prepare foamed cement at the wellsite is to mix a base cement slurry with all the additives except the surfactants and then inject the surfactants and the gas as the slurry is being pumped down hole.

3.3.2 Foamed cement properties

Laboratories testing of foamed cement under simulated downhole conditions is difficult. Because of the pressure and temperature dependence of the foam volume, curing a foamed cement at high pressure and temperature requires different equipment than that used for conventional slurries.

Mechanical properties

Foamed cement has a lower Young's modulus than conventional cements (Deeg et al, 1999). To achieve a lower Young's modulus with conventional cements, one must add large amounts of water, resulting in lower compressive strength. With foamed cement, the impact on compressive strength is lower. Cements with lower Young's moduli are less susceptible to failure when exposed to the common mechanical stresses associated with well operations.

Thickening time

Among the tests performed on foamed cement, thickening time is the most difficult to perform and the least conclusive. To be valid, this test should be performed under simulated downhole conditions, and the foam should be mixed in a manner comparable to what occurs on location. Thus, the slurry should be prepared in a pressurized mixer and transferred under pressure to the pressurized consistometer. Thickening time test involves measuring the evolution of slurry viscosity. Because of the particular rheological behavior of foam, the shear field in the consistometer is not uniform.

Instead of testing foamed systems, a common procedure is to measure the thickening time of the base slurry containing the additives, surfactants, and stabilizers.

Thermal and electrical conductivity

Short et al, (1961) reported that foams lower thermal conductivity, because of presence of gas voids and the lower amount of solids. Nelson (1986) reported that the thermal conductivity of cement systems is roughly proportional to slurry density, regardless of whether the cement was foamed.

Studies of the resistivity of foamed cement indicate that the electrical conductivity is similar to that of conventional cements (Smith et al, 1984).

3.3.3 Preparation and testing of foamed cement slurries at atmospheric pressure

3.3.3.1 Introduction

Laboratory testing of cements and cementing materials is an essential part of the cementing process. Testing begins at the cement and additive manufacturing sites to monitor product quality and continues through the slurry-design stages at the pumping service company or operating company laboratories. Samples are frequently obtained from the bulk plant as the blend is prepared, and samples are taken from storage silos when the blend is placed on location. Field samples of the dry cement blends and the resulting slurries can be obtained during mixing for subsequent evaluation, either in the laboratory or on location using portable laboratory equipment.

This section will review the laboratory testing procedures, calculations, and devices for cement testing defined in API RP 10B-4.

3.3.3.2 Base cement slurry preparation

The base slurries containing all additives, but without foaming surfactants, and its operational procedure in the laboratory are found in API RP 10B.

3.3.3.3 Preparation of foamed cement slurry at atmospheric pressure

General

After calculating the mass from equation (2) and (3), weight the appropriate amount of the prepared base slurry into the blending container (figure 9). Add the calculated amount of surfactant. The final mass of the base cement slurry and added surfactant.

$$m_s = m_{ubws} \times \frac{w_s}{100} \quad (2)$$

Where:

m_s is the mass of surfactant, expressed in grams;

m_{ubws} is the mass of unfoamed base cement slurry with surfactant, expressed in grams;

w_s is the mass fraction of surfactant expressed as a percent.

Cementing the 20 inches surface casing

$$m_{ubwos} = m_{ubws} - m_s \quad (3)$$

Where:

m_{ubwos} is the mass of unfoamed base cement slurry without surfactants, expressed in grams;



Figure 9: Blending container and multi-blade assembly (Courtesy of Baker Hughes)

Generation of a foamed cement slurry

Place the lid and plug on the container and seal it well (Figure 10). Mix the slurry at the 12000r/min setting for 15seconds using the blade assembly.

During the mixing, there will be a noticeable change in the sound from the blending container. After mixing there may be some slight pressure in the blending container, due to temperature

Cementing the 20 inches surface casing

increases and energy imparted to the foam during the foaming process. Care shall be exercised when removing the top of the blending container (Figure 11). After mixing open the sampling port or container lid, and check that the slurry completely fills the blending container (Figure 12).

If the slurry does not fill the blending container at the end of the 15 s period, it is doubtful the slurry will foam properly under field conditions. The procedure should be repeated.

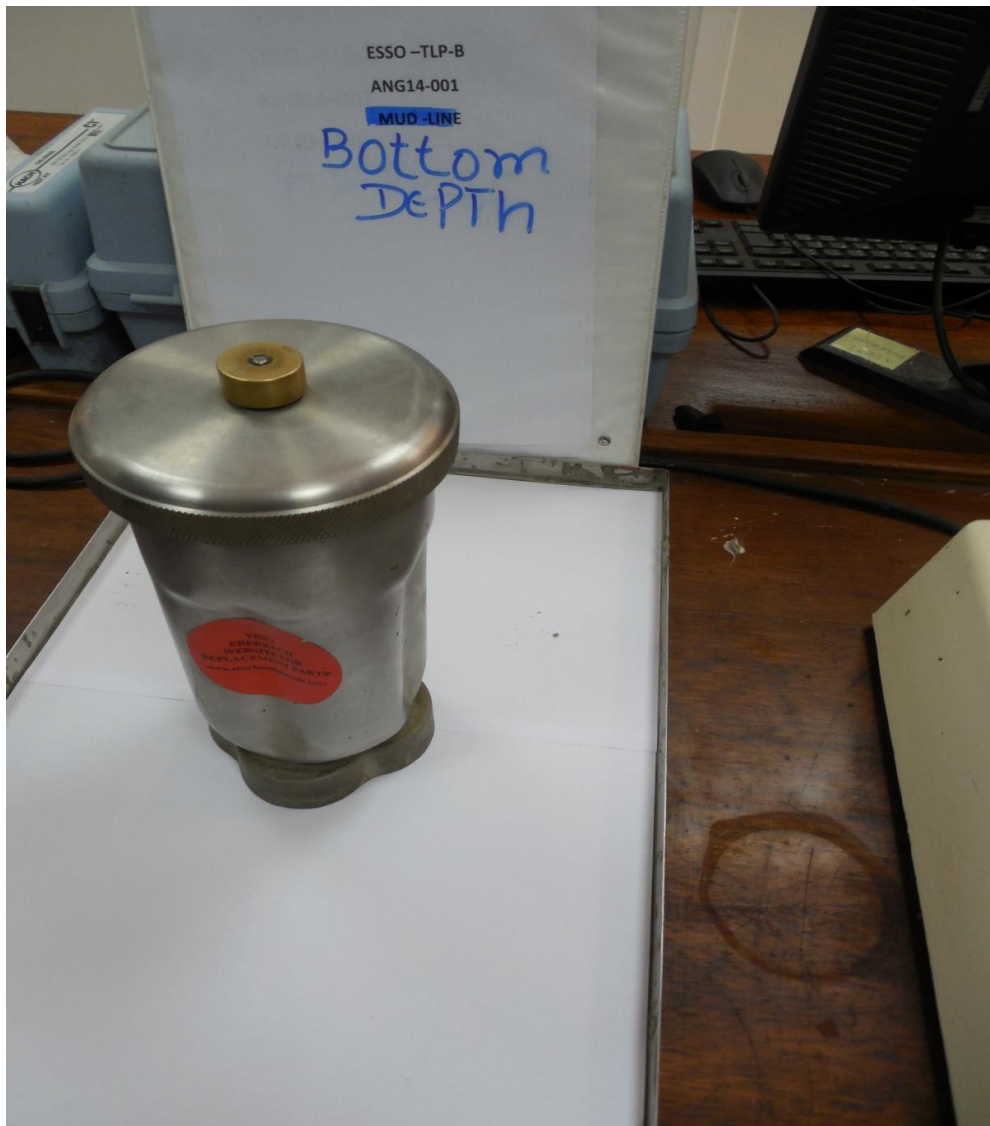

Figure 10: Sealed blending container (Courtesy of Baker Hughes-Angola)



**Figure 11: Slight pressure in the blending container due to temperature increases
(Courtesy of Baker Hughes-Angola)**



Figure 12: Check up of the cement slurry (Courtesy of Baker Hughes-Angola)

Compressive strength

Measured by a destructive crush test, pour the foamed cement slurry into 2" cubic moulds (Figure 13), and cured for various time periods at specific temperatures and pressures. The set-cement cubes are removed from the molds and placed in a hydraulic press, where increasing uniaxial load is exerted on each until failure. The compressive strength is calculated by dividing the load at which failure occurred by the cross-sectional area of the specimen.



Figure 13: Cube preparation and Crush cube

Stability

The stability must be tested to ensure that the gas will not break out of the slurry. If the gas coalesces and the size of the bubbles increases, gas pockets form and rise in the cement column, resulting in un-cemented sections or channels in the well. A simple test to evaluate stability involves two methods.

The first method is to pour a sample of the foamed cement into a graduated cylinder (figure 14). After two hours, the technician visually examines the foamed slurry for signs of instability, such as large coalescing bubbles or cement density variations caused by nitrogen bubble migration or escape.

The second method is to pour the foamed cement into a plastic cylinder, sealing it, and then allowing it to cure and set (figure 15). The technician then removes the solid cement sample from the cylinder and measures the density of solid cement at the top, middle, and bottom of the sample (figure 16). If there are density variations from top to bottom, or if the densities are equal to one another but significantly higher than the target density, the foamed cement is deemed unstable.

The API lists five signs of foamed slurry instability in the laboratory:

- More than a trace of free fluid;
- Bubble breakout noted by large bubbles on the top of the sample;

Cementing the 20 inches surface casing

- Visual signs of density segregation as indicated by streaking or light to dark color change from top to bottom;
- Excessive gap at the top of the specimen;
- Large variations in density from sample top to bottom.



Figure 14: Graduated cylinder for unset foam test (Courtesy of Baker Hughes Cementing Laboratory-Angola)



**Figure 15: Curing mold for set cement test
(Courtesy of Halliburton Cementing Laboratory)**

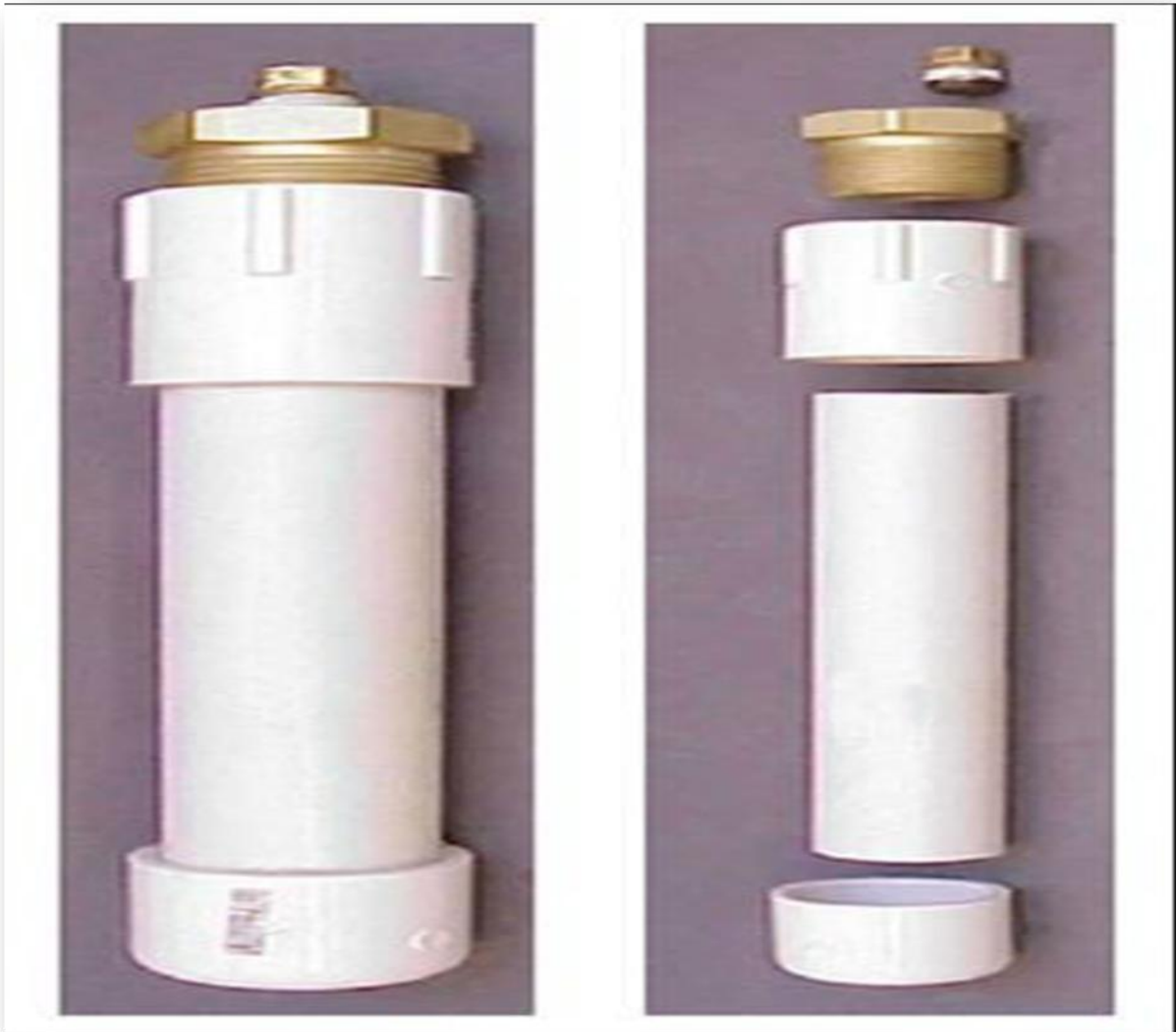

Figure 16a: Cement density test (API RP 10B-4)



Figure 16b: Cement density test (Courtesy of Baker Hughes Cementing Laboratory)

Example of cement density calculation using the second method, figure 16b

Determine the mass of four sections in air and in water as follow. Place a beaker of fresh water on a balance and tare the balance to zero. Place a section on the balance beside the beaker. Record the mass and remove the section from the balance. Tare the balance to zero. Place a noose of thin line around the section. Pick up the section by the line and suspend the section in the water in the beaker such that the sample is totally immersed in water and does not touch the bottom or sides of the beaker. Obtain the mass of the sample immersed in water as quickly as possible to prevent excessive water absorption. Remove the sample from the water. Repeat the procedure for each set cement section. By applying the Archimedes Principle. Calculate the density of each cement sample by:

$$\rho_s = \frac{m_a}{m_{sw}} \quad (4)$$

Where:

ρ_s is the density of the sample, [g/cm^3]

m_a is the mass of the sample in air, [g]

Cementing the 20 inches surface casing

m_{sw} is the mass of the sample in water, [g]

Weight (w) = mass multiplied by gravitational acceleration (g). $w = m \times g$; $m = \frac{w}{g}$

$$\rho_s = \frac{m_a}{m_w} = \frac{w}{w} = \frac{33,34}{21,89} = 1,52 \text{ SG} \rightarrow 1,523 \text{ SG} \times 8,345 = 12,70 \text{ ppg}$$

<u>Section</u>	<u>Weight in air</u>	<u>Weight in water</u>	<u>Density[SG]</u>	<u>Density [ppg]</u>
1	33,34 g	21,89 g	1,523	12,70
2	31,30 g	20,57 g	1,521	12,69
3	31,90 g	20,86 g	1,529	12,75
4	33,94 g	22,02 g	1,541	12,85

Calculation for the preparation of foamed cement slurry at atmospheric pressure as per API 10B-4

Problem: foaming a base cement slurry of density 1737 kg/m^3 with a 31% volume fraction of gas.

Slurry design: Cement + $0,01775 \text{ m}^3$ /tonne surfactant

Base Cement slurry density = 1737 kg/m^3

Surfactant density = 1198 kg/m^3

Desired volume fraction of gas = 31%

Container volume = 1170 cm^3

One tonne = 1000 kg

A.1 Mass percentage calculations

Obtain the mass of cement, surfactant, and water from the balance and then calculate its volume:

Cementing the 20 inches surface casing

Mass

Cement	1000 kg
0,01775 m^3 /tonne surfactant	21,3 kg
Water	590 kg
Total	1611,3 kg (1,6113 g)

Volume

$$\text{Cement: } v = \frac{m_c}{\rho_c} = \frac{1000 \text{ kg}}{3137,7 \text{ kg/m}^3} = 0,31870 \text{ m}^3$$

$$0,01775 \text{ m}^3/\text{tonne surfactant: } v = \frac{m_s}{\rho_s} = \frac{21,3 \text{ kg}}{1200 \text{ kg/m}^3} = 0,01775 \text{ m}^3$$

$$\text{Water: } v = \frac{m_w}{\rho_w} = \frac{590 \text{ kg}}{1000 \text{ kg/m}^3} = 0,59 \text{ m}^3$$

Where:

m_c mass of cement

ρ_c density of cement

m_s mass of surfactant

ρ_s density of surfactant

m_w mass of water

ρ_w density of water

$$\text{Total volume} = 0,92645 \text{ m}^3$$

Calculation of mass fraction (percent) contribution

$$\text{Cement: } w_c = \frac{m_c}{m_c + m_s + m_w} \times 100 = \frac{1000 \text{ kg}}{1611,3 \text{ kg}} \times 100 = 62,06\%$$

$$\text{Surfactant: } w_s = \frac{21,3 \text{ kg}}{1611,3 \text{ kg}} \times 100 = 1,3\%$$

$$\text{Water: } w_w = \frac{590 \text{ kg}}{1611,3} \times 100 = 36,6\%$$

Where:

w_c , w_s , and w_w are cement mass fraction, surfactant mass fraction, and water mass fraction respectively.

Cementing the 20 inches surface casing

A.2 Calculation of slurry density without surfactant

The density of the base cement slurry without surfactant (ρ_{bws}) is calculated by

	Mass	Volume
Cement	1000 kg	0,3187 m ³
Water	590 kg	0,59 m ³
Total	1590 kg	0,9087 m ³

$$\rho_{bws} = \frac{1590 \text{ kg}}{0,9087 \text{ m}^3} = 1749 \text{ kg/m}^3$$

A.3 Calculation of foamed cement slurry density with known volume fraction of gas

$$\rho_{fc} = \left(\frac{100-\varphi_g}{100}\right) \times \rho_{bws} = \left(\frac{100-31}{100}\right) \times 1749 \text{ kg/m}^3 = 1207 \text{ kg/m}^3 \text{ (1,207 g/cm}^3\text{)}$$

ρ_{fc} foamed cement slurry density with known volume fraction of gas

φ_g volume fraction of gas in the final foamed cement slurry

A.4 Calculation of required grams of unfoamed base cement slurry

The required grams of unfoamed base cement can be calculated by:

$$m_{ubws} = v_{bc} \times \rho_{fc} = 1170 \text{ cm}^3 \times 1,207 \text{ g/cm}^3 = 1412,2 \text{ g}$$

Where

v_{bc} blending container volume

m_{ubws} mass of unfoamed base cement slurry with surfactant to be placed in the blending container

A.5 Calculation of required grams of surfactant and slurry

The grams of surfactant to be placed into the mixer with the unfoamed base cement slurry is determined by:

$$m_s = m_{ubws} \times \frac{w_s}{100} = 1412,2 \times \frac{1,3}{100} = 18,36 \text{ g}$$

Cementing the 20 inches surface casing

Where:

m_s mass of surfactant

The mass of base cement slurry is:

$$m_{ubwos} = m_{ubws} - m_s = 1412,2 \text{ g} - 18,36 \text{ g} = 1393,8 \text{ g}$$

Where

m_{ubwos} mass of unfoamed base cement slurry without surfactant

m_{ubws} mass of unfoamed base cement slurry with surfactant

A.6 Summary of calculations

For preparing a foamed cement slurry sample from the slurry in a 1170 cm^3 container requires 1393,8 of base cement slurry and 18,36 g of surfactant.

4. FOAM CEMENT IN ANGOLAN OILFIELDS

4.1 Chissonga Development Project-Block 16.

The foam cement is being used in Angola by some operators with high success on the surface casing cement jobs, the main concern at this stage is not to bring the TOC until the mud line and left some no isolated zones with the 26"-20" annulus, based on the experience in Angola more than 180% of excess over the bit size is required to have cement returns at the sea floor, with the current capacity can be handle 150% or less bulk volume of lightweight blend at the rig silos, for instance for the simulated well requires 8400 ft^3 of neat cement to cover entire operation, if lightweight is intended to be used, the bulk capacity required is 12900 ft^3 , the TLWP planned capacity to store cement is 8000 ft^3 .

Slurry density is determined by the base slurry density and the volume percent of the gaseous phase at downhole conditions, which is termed foam quality. By limiting foam quality to less than 35%, compressive strength is similar to the base cement strength and low-permeability cements can be obtained. Table 6 illustrates Halliburton surface casing from cement jobs in Angola and photo 1 shows the ESSO Kizomba TLWP similar to the one being designed and promptly to be built by Maersk Oil.

Table 6 Halliburton surface casing from cement jobs in Angola

Field	No of foam cement jobs	Shallowest Water Depth (m)	Max Water depth (m)	Date
Block 15	120	722	1,363	2004 onwards
Block 14	65	17	3,938	1999 onwards
Block 18	13	1,498	2,474	2005-2007 2011
Block 21	3	1,501	1,615	2011-2012



Photo1 ESSO kizomba TLWP

4.2 Source of liquid nitrogen in Angola

In Luanda Angola, Baker Hughes has two main providers of liquid nitrogen namely Angases and Gastic, the preferred option is Angases which is currently providing the product for the cementing operations for BP and CT operations for Sonangol and they are able to supply volumes larger than 8000 gals in less than three days.

BJ Services Angola has currently 02 sets of foam cement (01 control cabin) under BP contract and is currently sourcing 4 additional sets (02 control cabin) for the potential contract with other operator in Angola. Figure 17 a), shows foam cement typical equipment configuration, Figure 17 b), the process of foaming lightweight cement and Photo 2 shows the Nitrogen unit.

Cementing the 20 inches surface casing

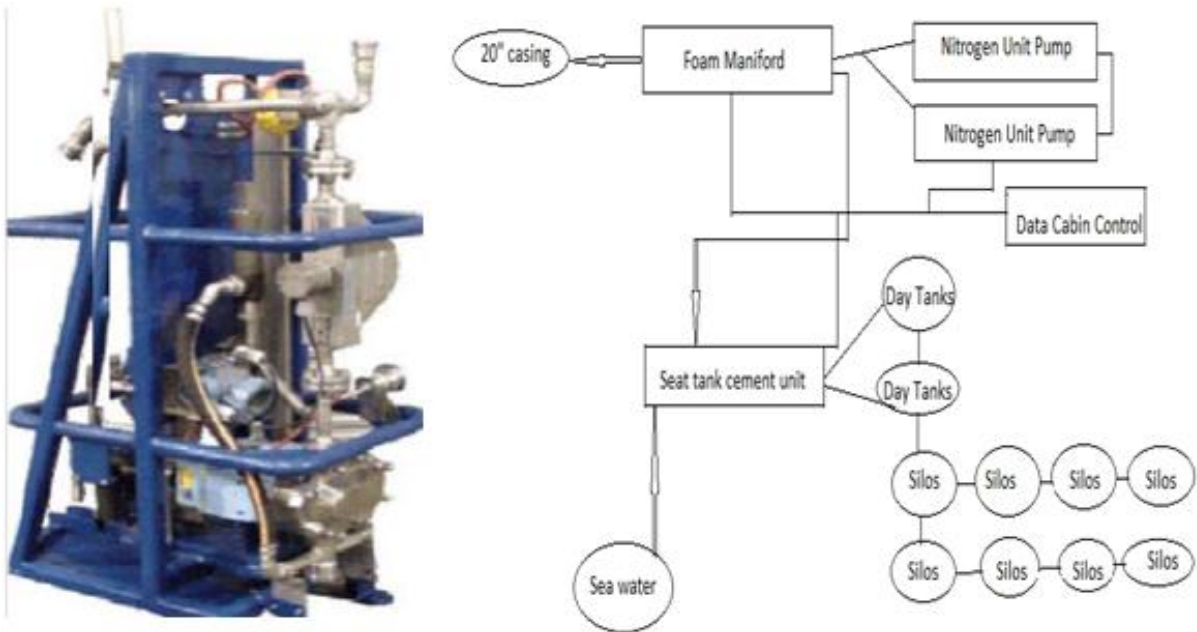

Figure 17a: Foam cement typical equipment configuration

Foamer Unit



Injection Manifold

Cementing the 20 inches surface casing

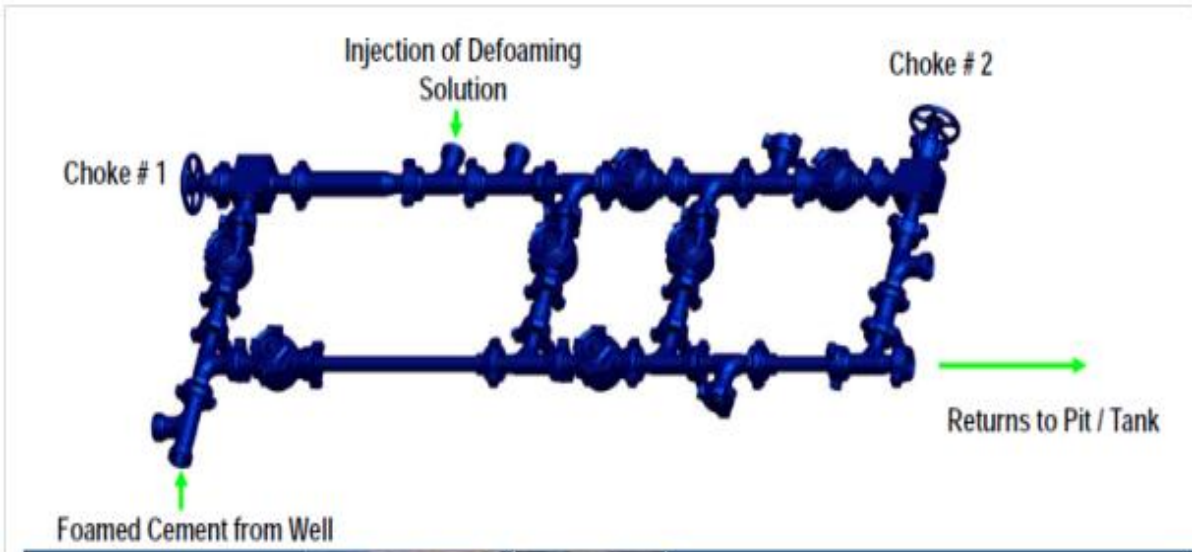

Defoamer Manifold



Nitrogen Tanks

Cementing the 20 inches surface casing



Cement Unit

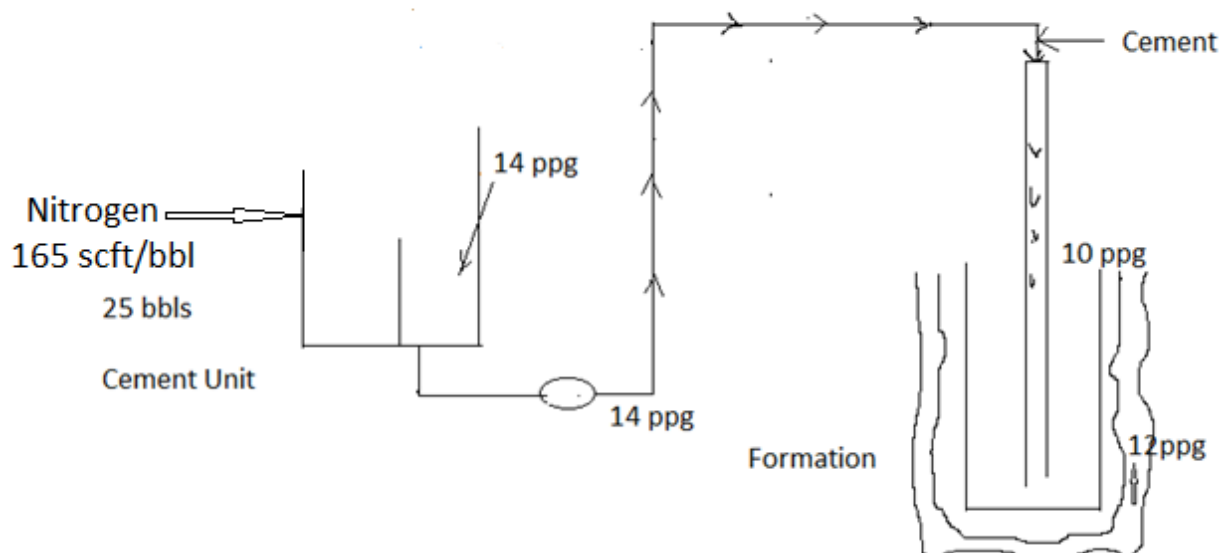

Figure 17b Injection of nitrogen into the lightweight cement

Cementing the 20 inches surface casing

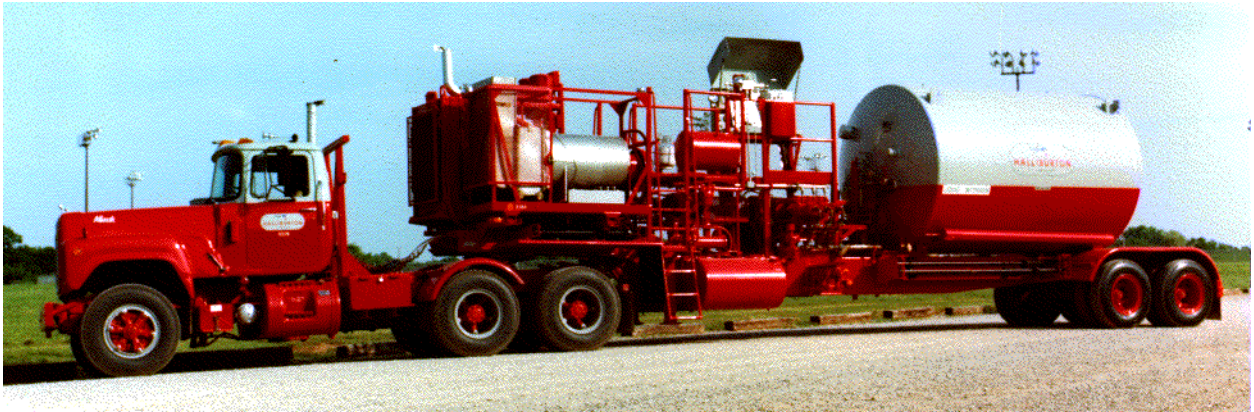

Photo 2 Nitrogen Unit

Foamed Cement Personnel Requirements

- One Foam Coordinator;
- One Electronics technician;
- One Mechanic;
- Two Nitrogen pump operators;
- One Cement Crew (2people),etc

4.3 Cement calculations

Figure 18 shows the data used to perform some cement calculations in Chissonga well.

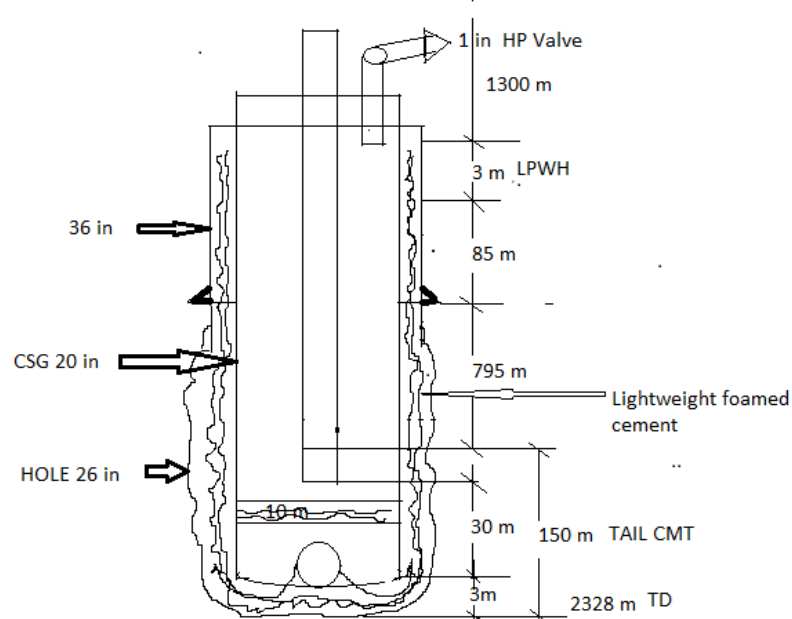

Figure 18: Chissonga Well (20" casing cement job)

Cementing the 20 inches surface casing

Determine cement volume

There are two parts needed to calculate in order to get total cement volume, as listed below:

1. Lead cement
2. Tail cement

The cement volume is based on annular capacity multiplied by cement length of each section.

Lead cement

$$\frac{795 \text{ m}}{0,3048} = 2608,2 \text{ ft}$$

$$\text{Volume between open hole and 20" casing: } \frac{26^2 - 20^2}{1029,4} \times 2608,2 = 699,30 \text{ bbl}$$

Excess. 200%

$$\text{Excess volume: } 699,30 \text{ bbl} \times 3 = 2097,9 \text{ bbl}$$

$$\text{Total open hole volume: } 699,30 + 2097,9 = 2797,2 \text{ bbl} \times 0,15899 = 445 \text{ m}^3$$

Previous casing details:

Size: 36"

ID: 33"

$$\frac{85 \text{ m}}{0,3048} = 278,87 \text{ ft}$$

$$\text{Volume of previous casing} = \frac{33^2 - 20^2}{1029,4} \times 278,87 \text{ ft} = 186,65 \text{ bbl} \times 5,62 = 1049 \text{ ft}^3$$

$$\text{Total lead} = 2797,2 + 186,65 = 2983,85 \text{ bbl} = 474,40 \text{ m}^3 = 16752,9 \text{ ft}^3$$

$$\text{sacks required: } \frac{\text{total slurry volume [ft}^3]}{\text{yield}} = \frac{16752,9}{2,13} = 7865,2 \text{ sx}$$

$$\text{Seawater required: } \frac{\text{H}_2\text{O ratio} \times 7654,46}{42} = \frac{12,186 \times 7865,2}{42} = 2282 \text{ bbl}$$

Cementing the 20 inches surface casing

Tail cement

$$\frac{150 \text{ m}}{0,3048} = 492,12 \text{ ft}$$

New casing details:

Size: 20"

ID: 18,730"

$$\text{Volume of casing: } \frac{18,730^2}{183,35} \times 492,12 = 941,59 \text{ ft}^3 = 167,5 \text{ bbl} = 26,66 \text{ m}^3$$

Volume of shoe track

$$\frac{10 \text{ m}}{0,3048} = 32,8 \text{ ft}$$

$$\frac{18,730^2}{1029,4} \times 32,8 \text{ ft} = 11 \text{ bbl} \times 5,62 = 61,82 \text{ ft}^3 = 1,75 \text{ m}^3$$

$$\text{Total tail: } 941,59 + 61,81 = 1003,4 \text{ ft}^3 / 5,62 = 178,54 \text{ bbl} = 28,41 \text{ m}^3$$

$$\text{sacks required: } \frac{1003,4}{1,34} = 748,8 \text{ sx}$$

$$\text{Seawater required: } \frac{6,369 \times 748,8}{42} = 113,5 \text{ bbls}$$

$$\text{Total volume: Lead cement + Tail cement} = 16752,9 + 1003,4 = 17756,3 \text{ ft}^3 = 502,8 \text{ m}^3$$

$$\text{Total Sacks: } 7865 + 749 = 8614 \text{ sx}$$

$$\text{Total bbl: } 2983,85 + 178,54 = 3162,39 \text{ bbl}$$

Displacement calculations

Drill pipe:

$$\text{ID}^2 \text{ drill string} \times 0,0009714 \times \text{bottom of drill string} = 4,990^2 \times 0,0009714 \times 4265 = 103 \text{ bbl}$$

$$\text{Casing: } \frac{18,730^2}{1029,4} \times (7637,7 - 4232) = 1160 \text{ bbl}$$

$$\text{Total displacement: } 103 + 1160 = 1263 \text{ bbl} \times 5,62 = 7098 \text{ ft}^3 \times 0,028317 = 200,9 \text{ m}^3$$

Cementing the 20 inches surface casing

Summary of cement calculations presented above.

Bit Size: 26 inches		TD: 2328 m			
Casing Size: 20 inches		Shoe : 2325 m			
		WD to Wellhead : 1300 m			
Drill String Details					Bottom of ID
Size	Weight	Grade	Conn.	D/String	inches
6-5/8 inches	40,7 lb/ft	S-135	4,5IF	4265	4,990
Previous casing Details					Shoe ID
Size	Weight	Grade	Conn.	Depth(m)	(inches)
36 inches	373,80 lb/ft	B	BTC	1300	33
New casing Details					Shoe ID
Size	Weight	Grade	Conn.	Depth(m)	(inches)
20 inches	133 bl/ft	X-56	ABB-Vetco	2325	18,730
Mud wt				Mud type	
11,5 ppg Pad Mud Weight				Sea-Material	
Volume Calculations					
Lead Cement					
Annulus open hole:		699,30 bbl		T.O.C: 1310 MT/MD	
% Excess: 200		2097,9 bbl		Density: 11,50 ppg	
Annulus of Csg:		186,65 bbl		H_2O Ratio: 12,186 gal/sx	
Total Slurry Volume:		2983,85bbls		Water Required: 2221 bbl	
Total Cubic ft.:		16752,9 cu/ft		Yield: 2,13 Cu.ft/sx	
				Sx. Required: 7654,46 Sacks	
Tail Cement					
Cased annulus:		178,54 bbl		Tail cmt above shoe: 150 m	
Rate hole:		0 bbl		Density: 15,0 ppg	
% Excess: 0		0 bbl		Water Ratio: 6,369 gal/sx	
Floats:		0 bbl		Water Required: 113,5 bbls	
Total Slurry Vol.:		178,54 bbl		Yield: 1,34 Cu.ft/sx	
Total Cubic ft.:		1003,4 Cu/ft		Sx. Required: 748,8 Sacks	

Foam Cement

Lead

$$\text{Sacks Required: } \frac{16752,9}{1,285} = 13037,2 \text{ sx}$$

$$\text{Water Required: } \frac{8,904 \times 13037,2}{42} = 2763,88 \text{ bbl}$$

Tail

$$\text{Sacks Required: } \frac{1003,4}{1,172} = 856 \text{ sx}$$

$$\text{Water Required: } \frac{6,368 \times 856}{42} = 129,7 \text{ bbl}$$

$$\text{Total Sacks: } 13037,2 + 856 = 13893,2 \text{ sx}$$

5. SIMULATION OF CEMENTING 20" SURFACE CASING IN DEEP WATER OF ANGOLA

In order to perform software packages to determine 2D hydraulics, 3D hydraulics, dynamic temperature simulator (WellCat) by Halliburton, the following information was needed:

- Cementing objective per string - Cement to seabed
- Directional plan: 0° - Shoe 30°
- Drill Pipe Management Plan (what drill pipe's will be used to run casing/liners, provided capacity factors, collar information, surge reduction tool?) - 6 5/8" 47,06 ppg
- Temperature Plot - BHST profile
- Shoe - depth
- Is it possible to rotate the pipe? no
- Open Hole Excess - 200%
- Centralizer Data - STA4NW-STNW-Cen(Bow-Type)20*26
- Light Cement: 11,50 ppg Lead + 15,00 ppg Tail
- Pad Mud - 11,5 ppg, YP-25-30 API<15 ml, ph 8-8,5, etc.

5.1 Lightweight Lead & Tail. Offshore

5.1.1 Job Design

Overview

Job Type: Primary Cement job

Injection Path: Casing/Conventional

Foam Job: no

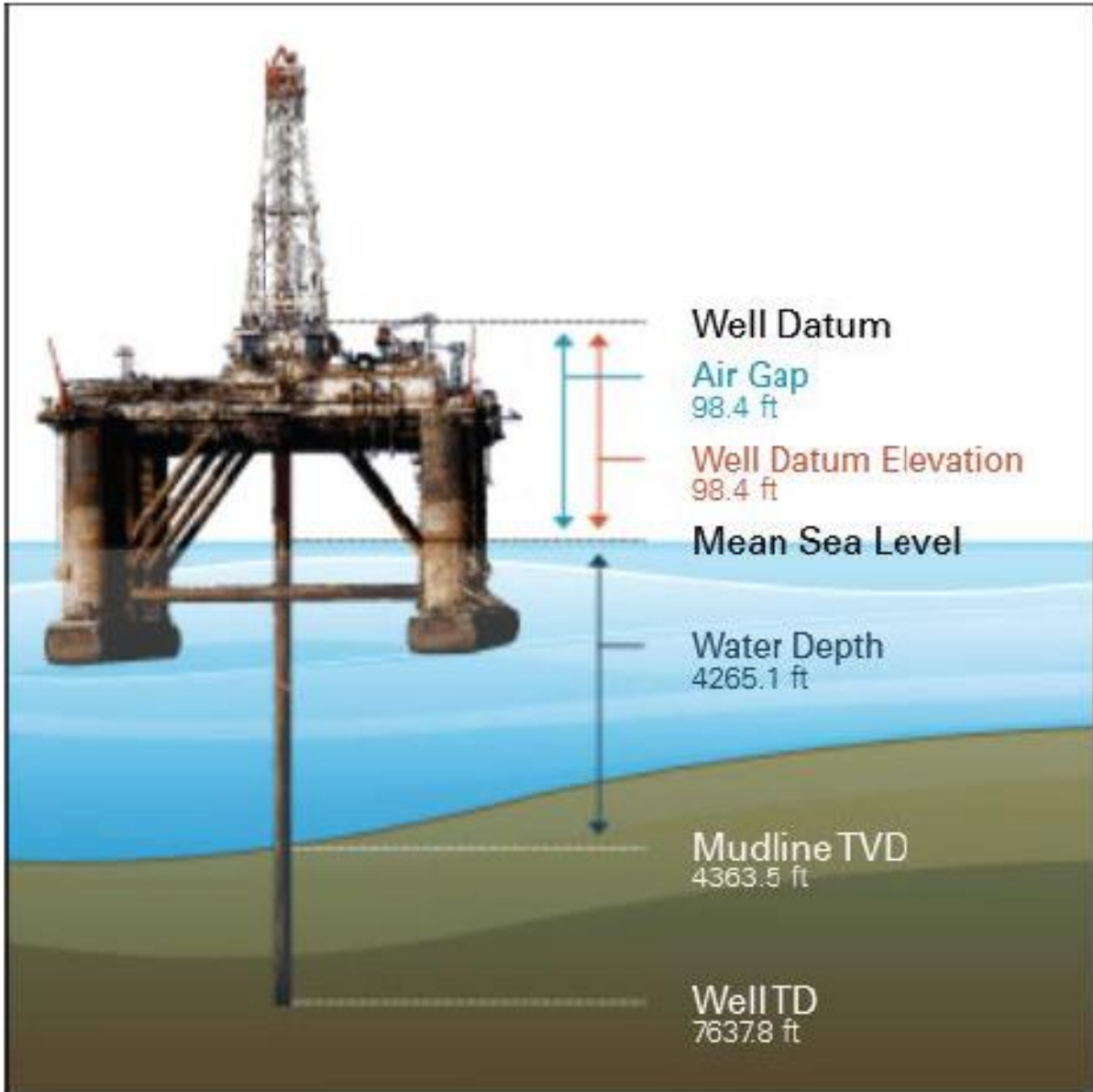

Figure 19: Simulation Performed. 2D Hydraulics, Rheological Hierarchy, Standoff

Cementing the 20 inches surface casing

2D Wellbore Schematic

Casing Volume: 269,41 bbl

Annulus Volume: 2541,66 bbl

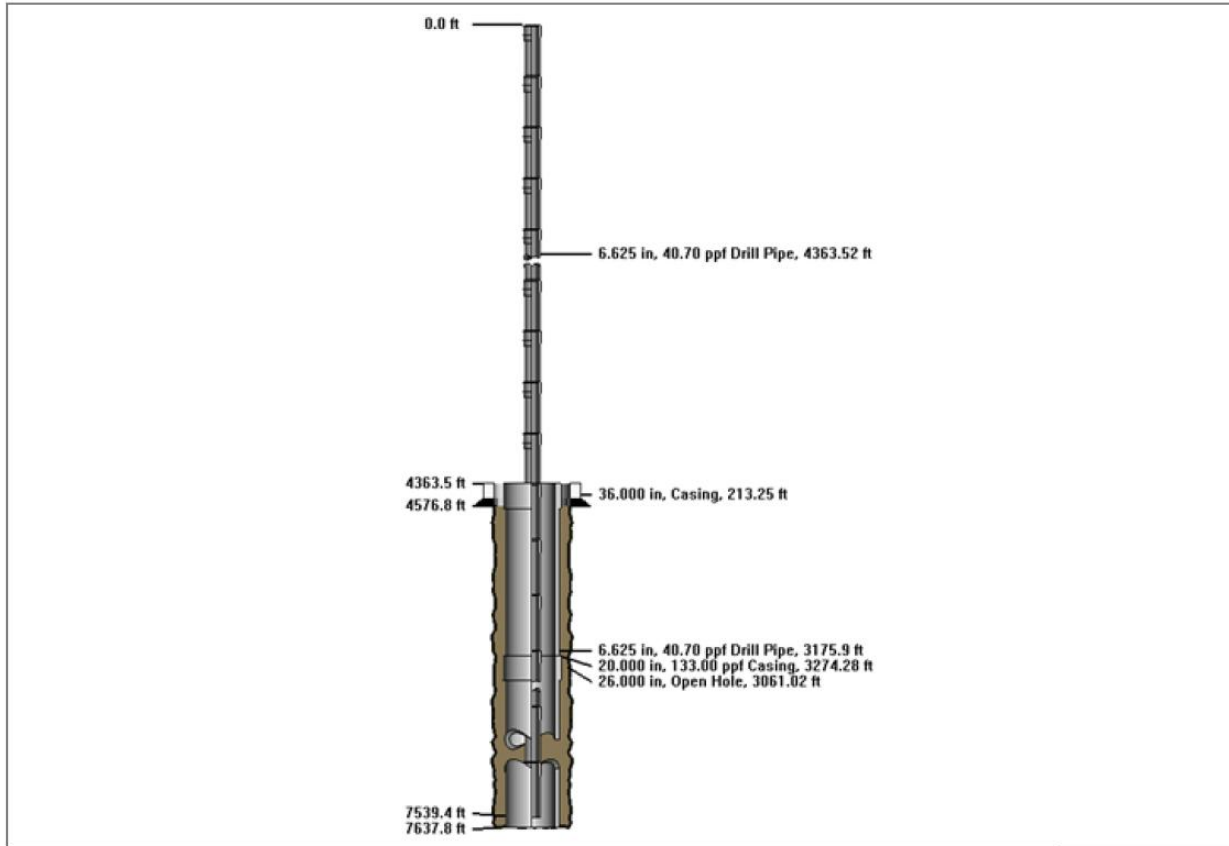

Pump Schedule

Description	Stage no	Density (ppg)	Rate (bbl/min)	Yield (cu.ft/sk)	Water Required (gal/sk)	Volume (bbl)	Bulk Cement (94 lb sacks)	Duration (min)
Angola-Pad Mud	1	11,50	5,00			0,00		0,00
Sea Water	2	8,54	5,00			100,00		20,00
Angola-Lead Cement	3	11,50	5,00	2,1300	12,186	2145,82	5656,28	429,16
Angola-Tail Cement	4	15,00	5,00	1,3400	6,369	407,02	1705,40	81,40
Top Plug/Start Displacement								
Sea Water	5	8,54	8,00			258,23		32,28
Total						2911,07		562,85

Cementing the 20 inches surface casing

Time of Stages

Graph Label Annulus	Time (min)	Stage Starts Pumping	Stage Enters
1	0	Seawater	
2	20	Angola-Lead Cement	
3	44,9		Seawater
4	61,4		Angola- Lead Cement
5	449,2	Angola-Tail Cement	
6	481,8		Angola-Tail Cement
7	530,6	Seawater	
8	562,8	Plug Landed	

Final 2D Fluid Positions

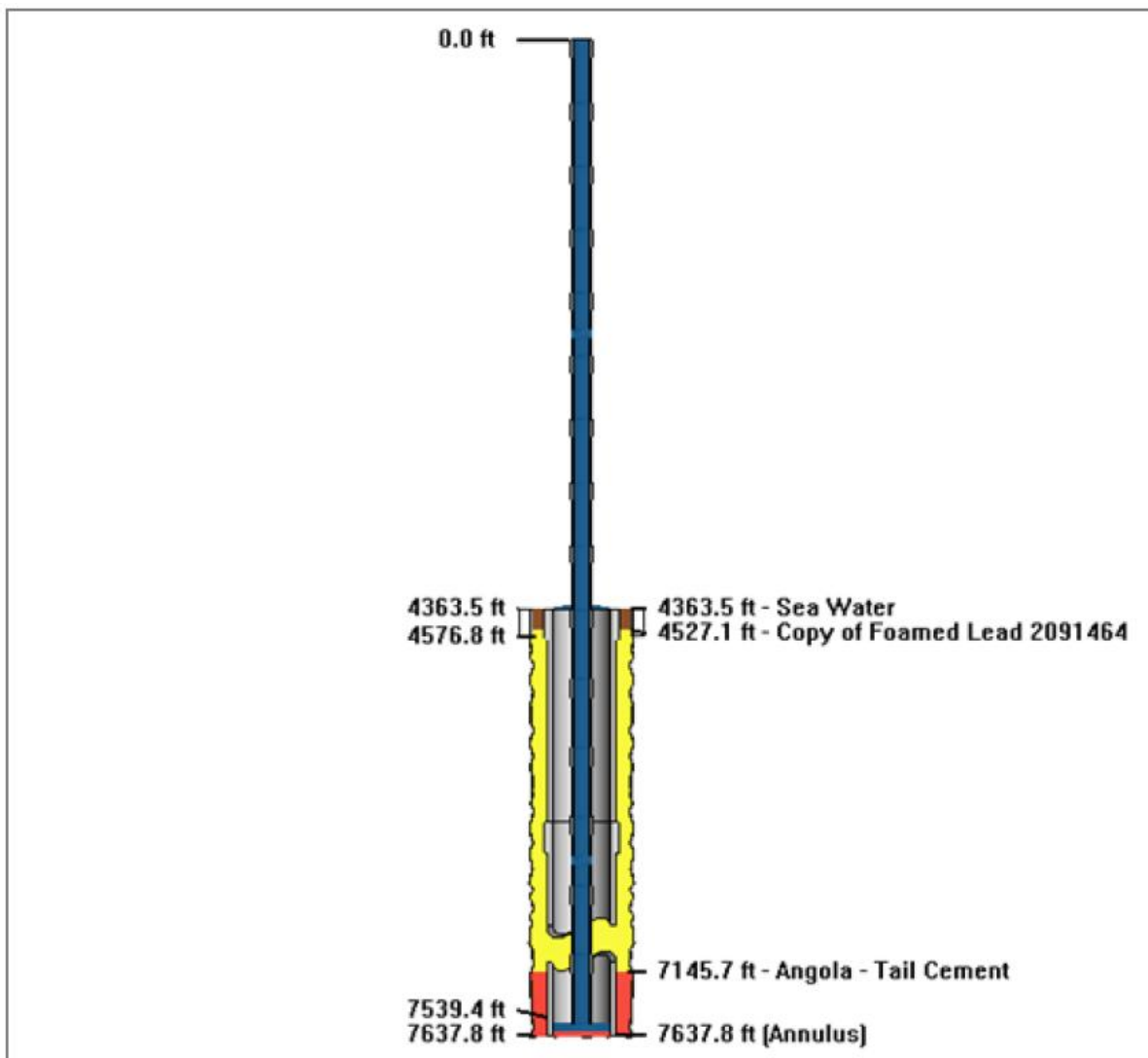

Cementing the 20 inches surface casing

ECD & Hydrostatic Pressure Plot at Fracture Zone

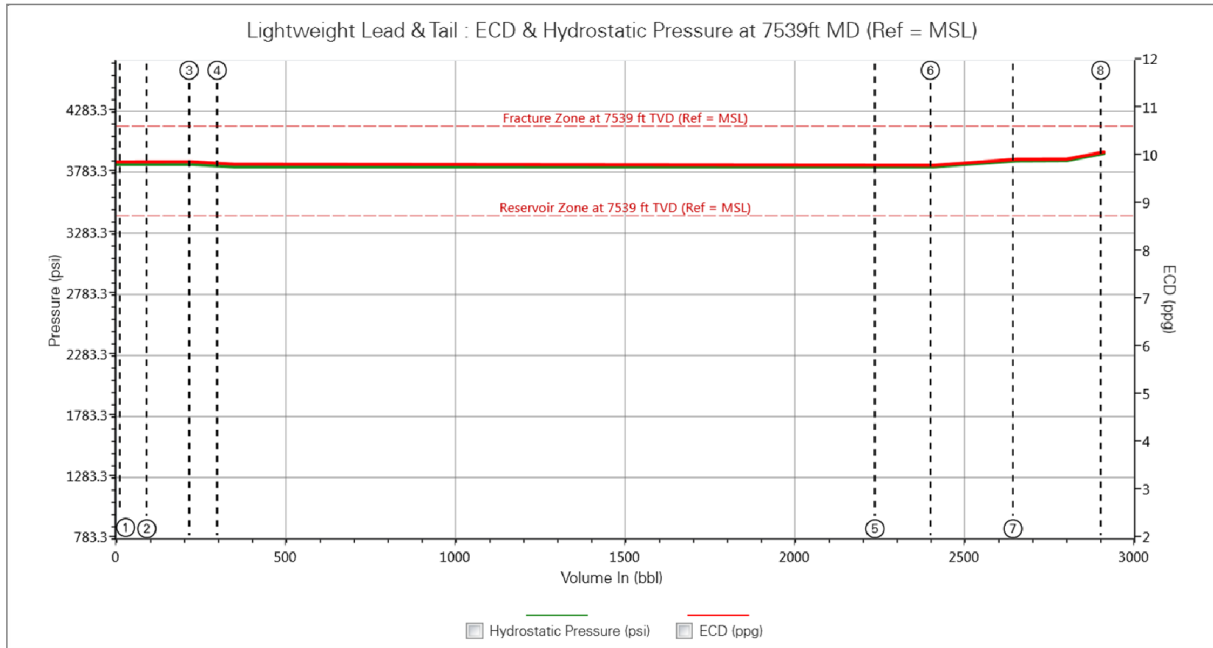

Calculated Surface Pressure Plot

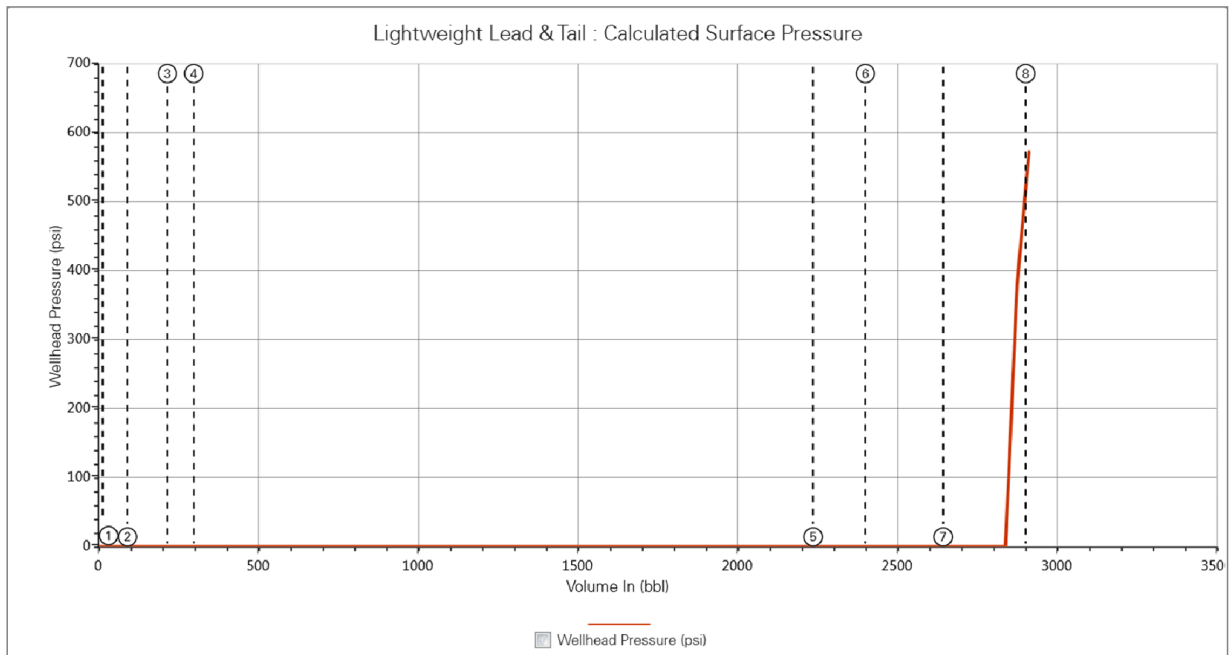

Cementing the 20 inches surface casing

Flow Potential Plot

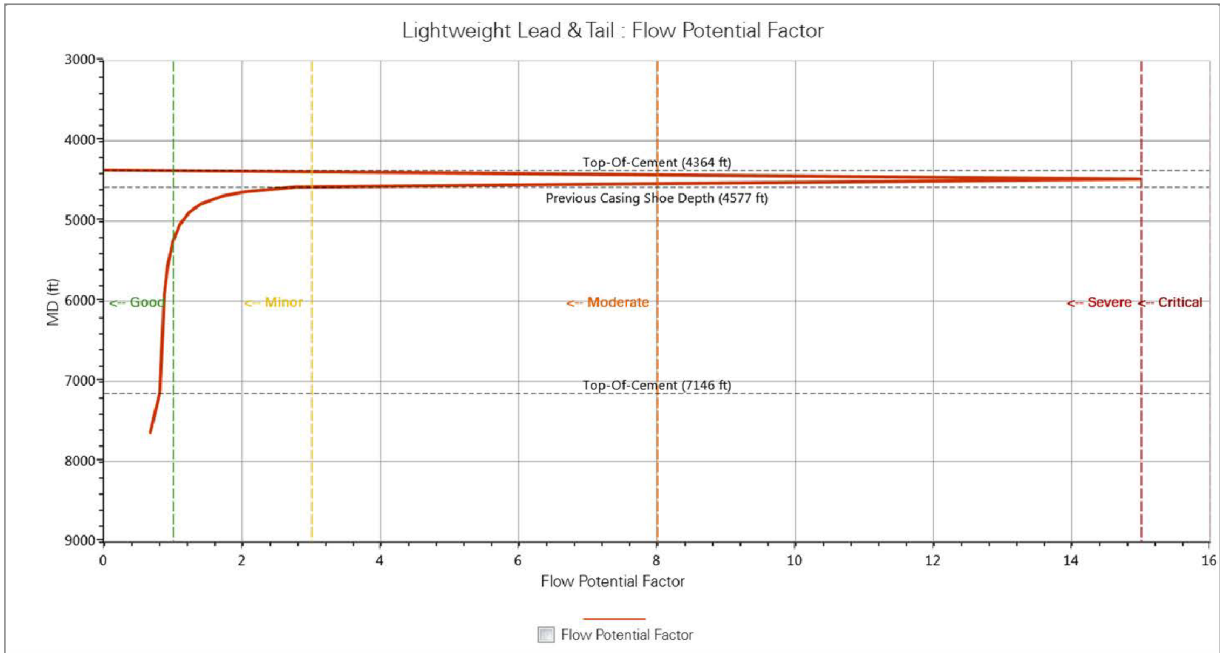

Critical Static Gel Strength Plot

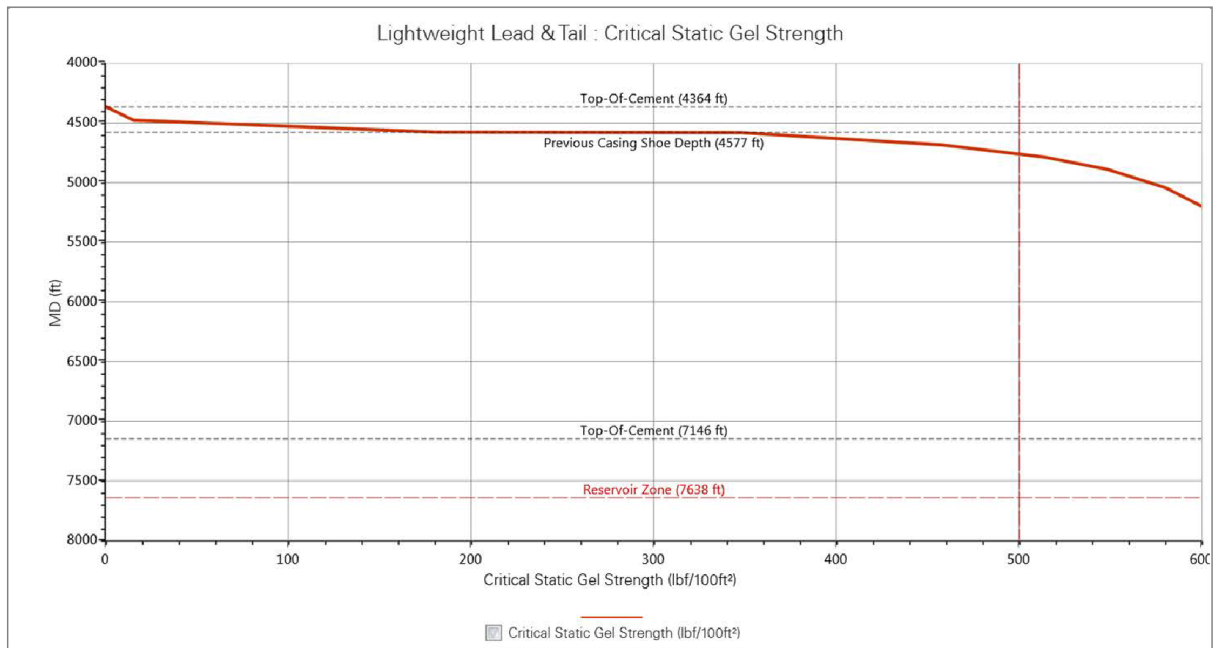

Cementing the 20 inches surface casing

Downhole Pressure Profiles Plot

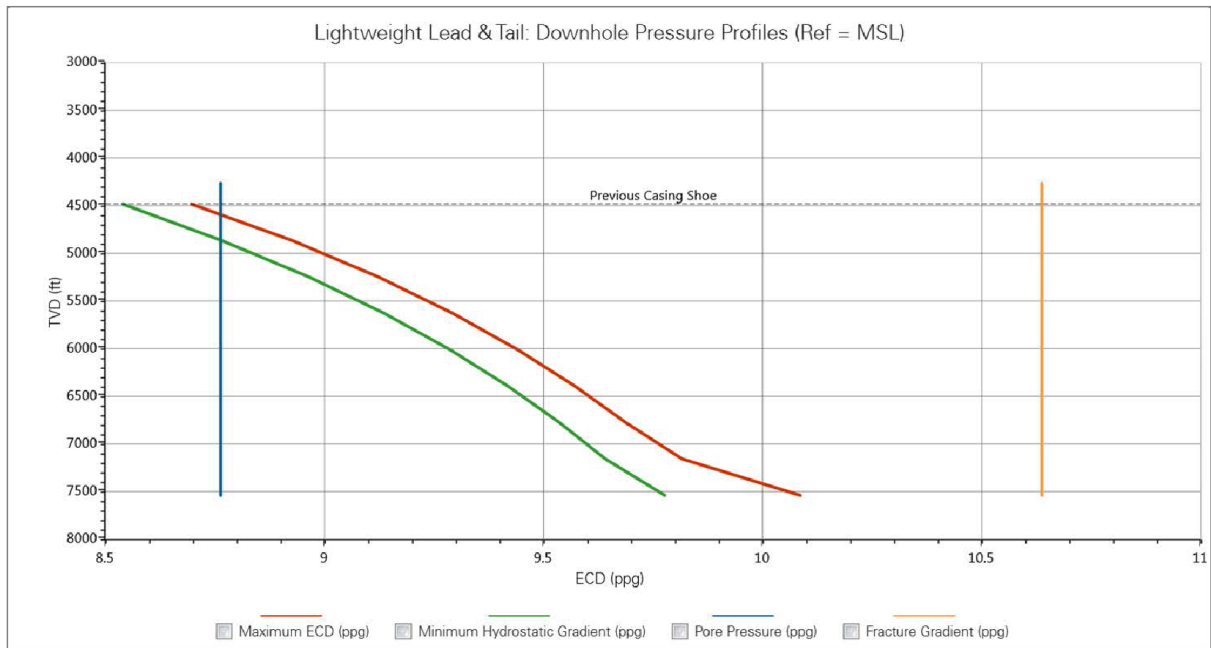

Pure Fluid Rheology

Fluid Name	Rheology Model	Temp (°F)	τ_0 (YP) (lbf/100ft ²)	μ_{∞} (PV) (cp)	m	n	k (lb*s ⁿ /ft ²)
Angola-Pad Mud	Bingham Plastic	80,0	25,0	40	1,00	1,00	
Sea Water	Bingham Plastic	80,0	0,0	1,0	1,00	1,00	
Angola-Lead Cement	Bingham Plastic	80,0	12,0	25,0	1,00	1,00	
Angola-Tail Cement	Bingham Plastic	80,0	28,0	18,0	1,00	1,00	
Sea Water	Bingham Plastic	80,0	0,0	1,0	1,00	1,00	

Rheological Hierarchy Plot at Reservoir Zone

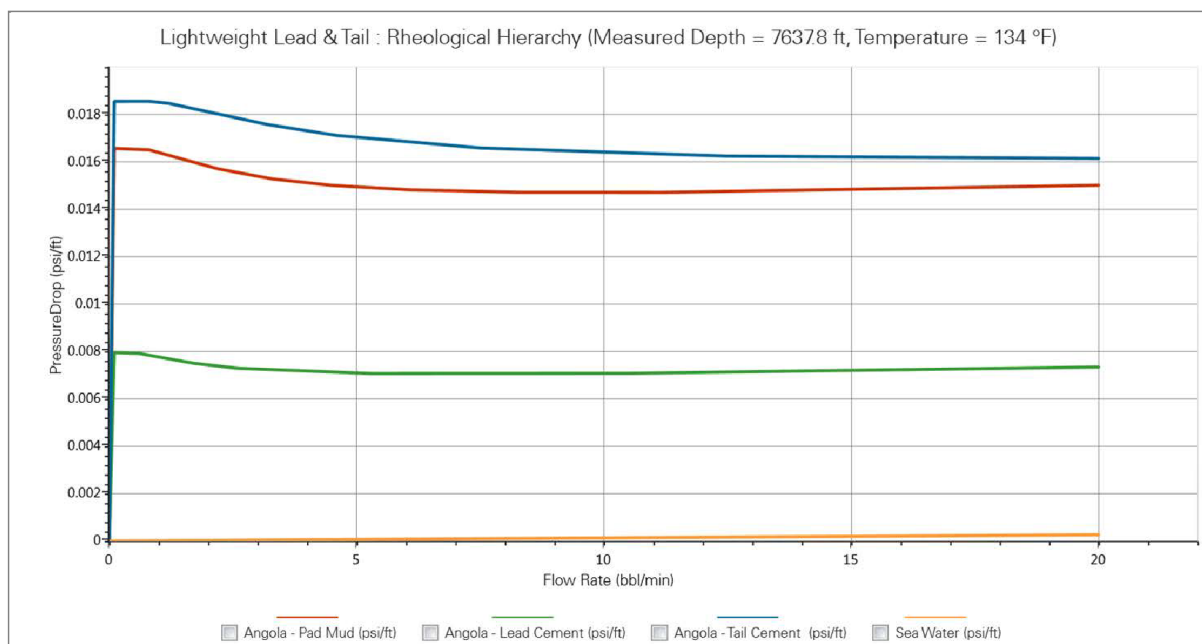

Cementing the 20 inches surface casing

Temperature Modeling

Beginning-Job Temperature Profile Plot

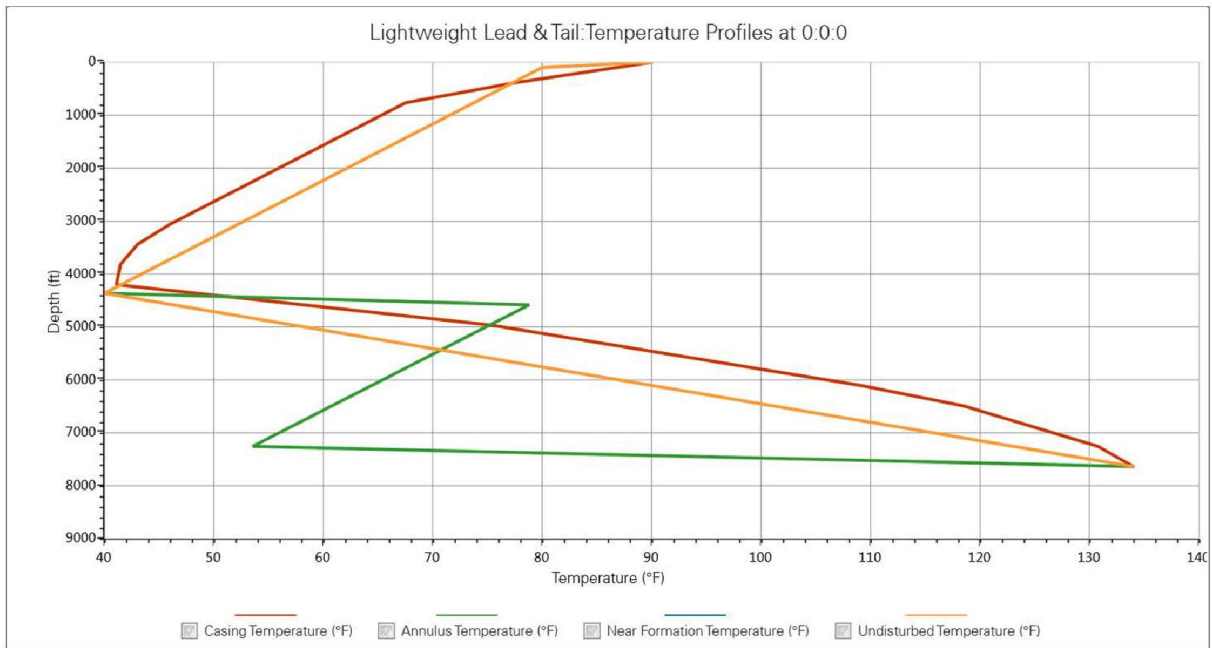

Slurry Placement Temperature Plot

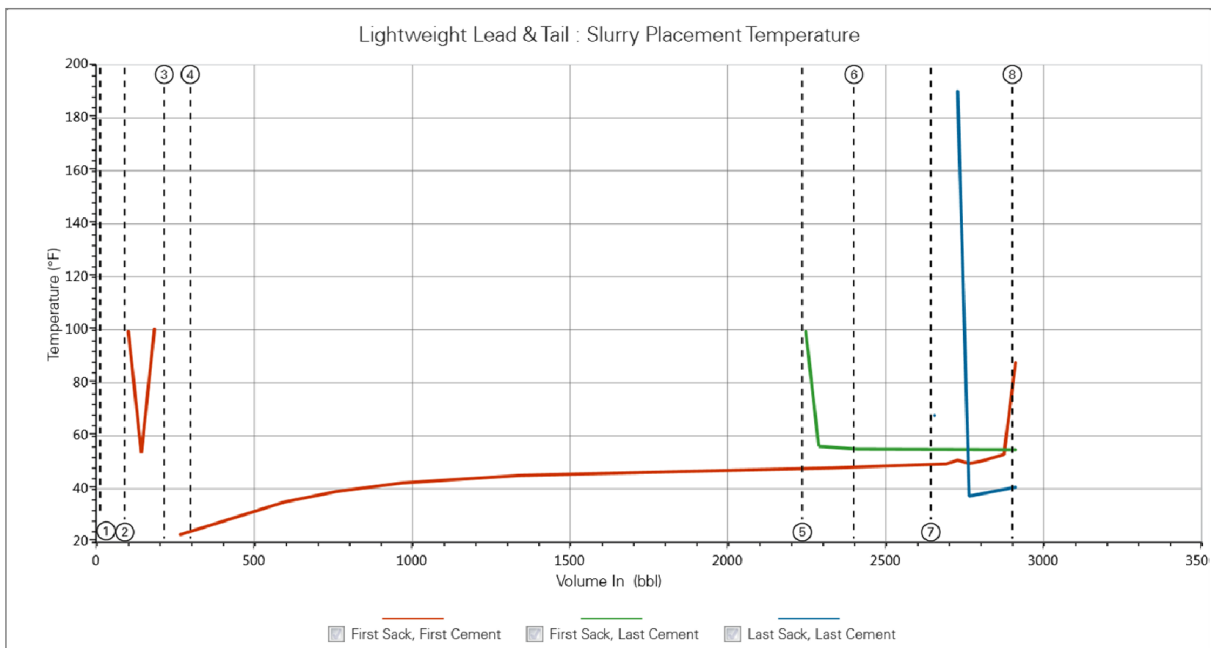

Cementing the 20 inches surface casing

Wait on Cement Plot

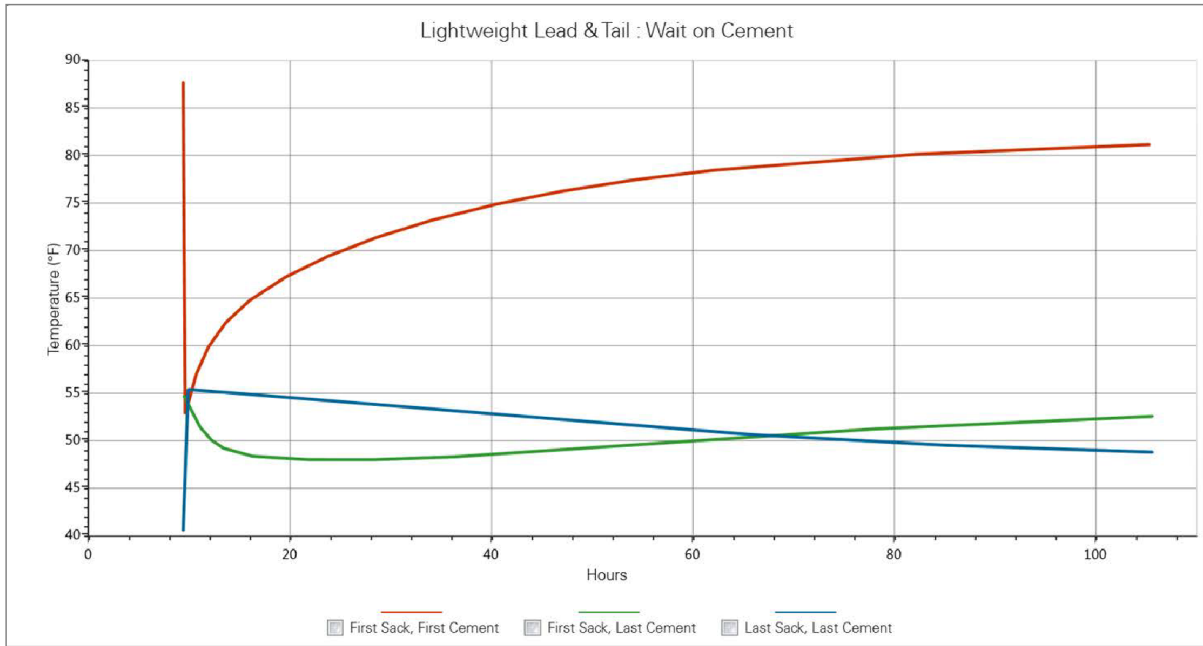

Mud Erodiability Profile Plot

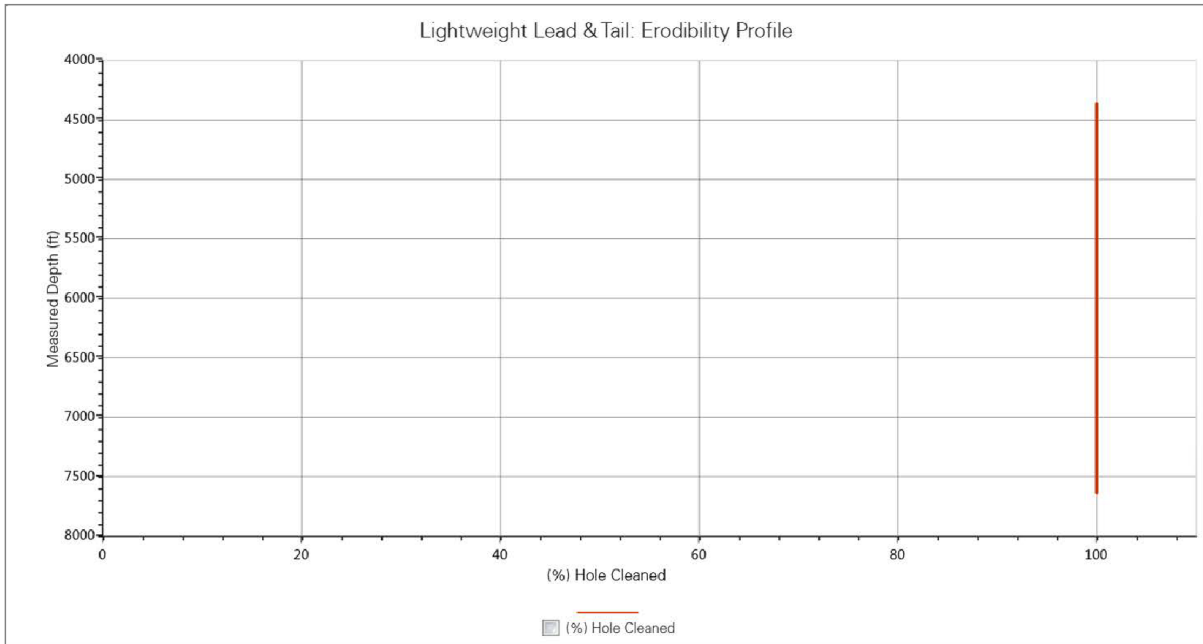

Cementing the 20 inches surface casing

Final Density & Hydrostatics Profile Plot

Centralization



Centralizer Specifications

Centralizer Part Number	Type	COD (in)	Hole Dia. (in)	Nom.Dia. (in)	Min.Dia. (in)	Rest.Force (lbf)	Bows	Total
100004530	85	20,0	26,0	26,50	22,750	800,0	10	58
100004530	85	20,0	26,0	26,50	22,750	800,0	10	28

Centralized Intervals

Top MD (ft)	Bottom MD (ft)	Cent.A	No. of Cent.A in interval	Cent.B	No. of Cent.B in interval	Required Standoff
4642,4	7053,0		58			
7053,8	7637,8		28			

Cementing the 20 inches surface casing

Standoff Profiles Plot

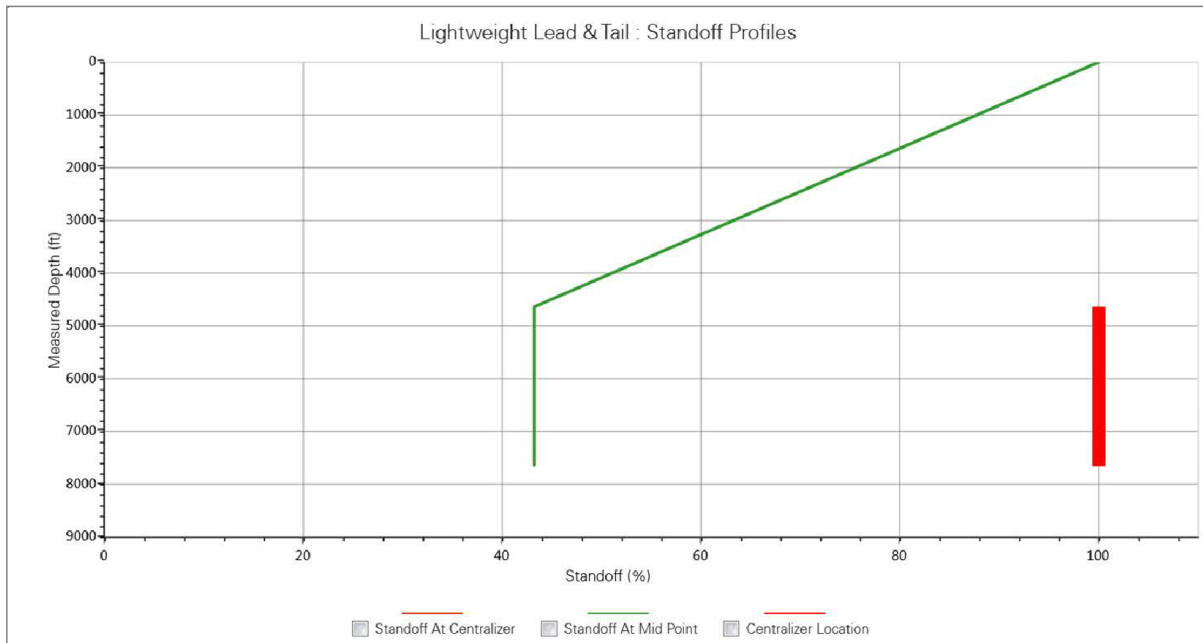

Foamed Cement. Offshore

2D Wellbore Schematic

Casing Volume: 269,41 bbl

Annulus Volume: 2541,66 bbl

Pump Schedule

Description	Stage no	Density (ppg)	Rate (bbl/min)	Yield (cu.ft/sk)	Water Required (gal/sk)	Volume (bbl)	Bulk Cement (94 lb sacks)	Duration (min)
Angola-Pad Mud	1	11,50	5,00			0,00		0,00
Sea Water	2	8,54	5,00			100,00		20,00
Copy of Foamed Lead 2091464/ Foamed	3	16,50	5,00	2,1800	4,209	1200,66	3092,28	240,13
Angola-Tail Cement	4-1	15,00	31,45	1,3400	6,369	395,84	1658,55	12,59
Angola-Tail Cement	4-2	15,00	31,45	1,3400	6,369	11,18	46,85	0,36
Top Plug/Start Displacement								
Sea Water	3	8,54	8,00			258,23		32,28
Total						1965,91		305,35

Cementing the 20 inches surface casing

ECD & Hydrostatic Pressure Plot at Reservoir Zone

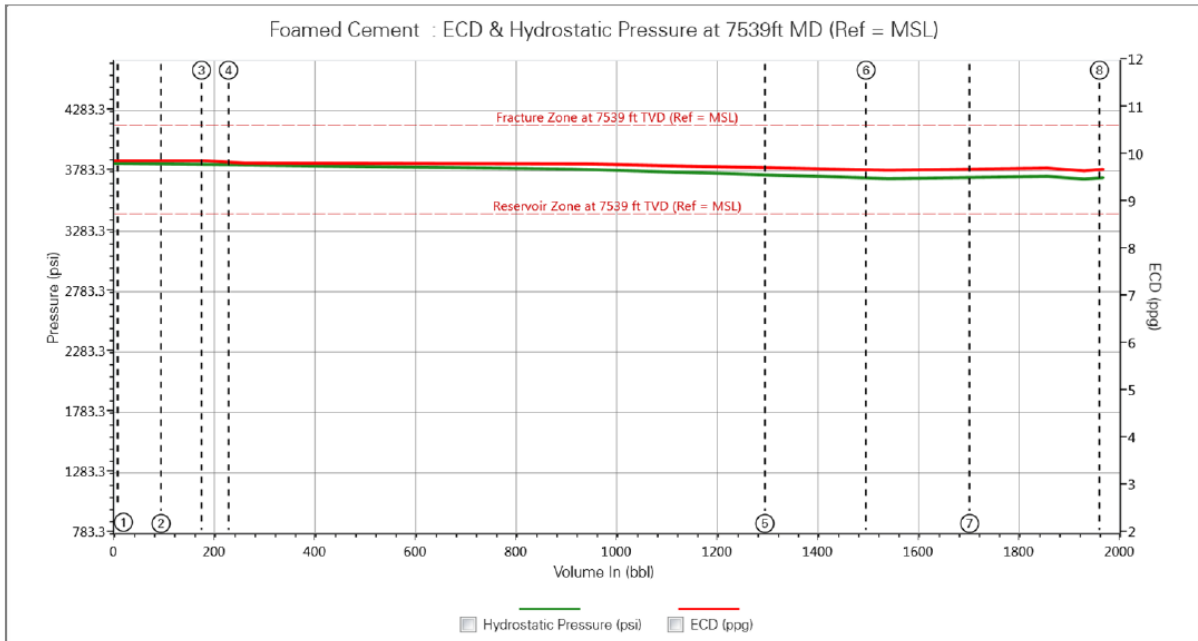

Comments: As it can be noticed, with Foamed Cement there is no risk of having problem of losses, there is no variation in ECD, and Hydrostatic pressure of the fluid column is below the fracture gradient even when the volume is increased.

ECD & Hydrostatic Pressure Plot at Fracture Zone

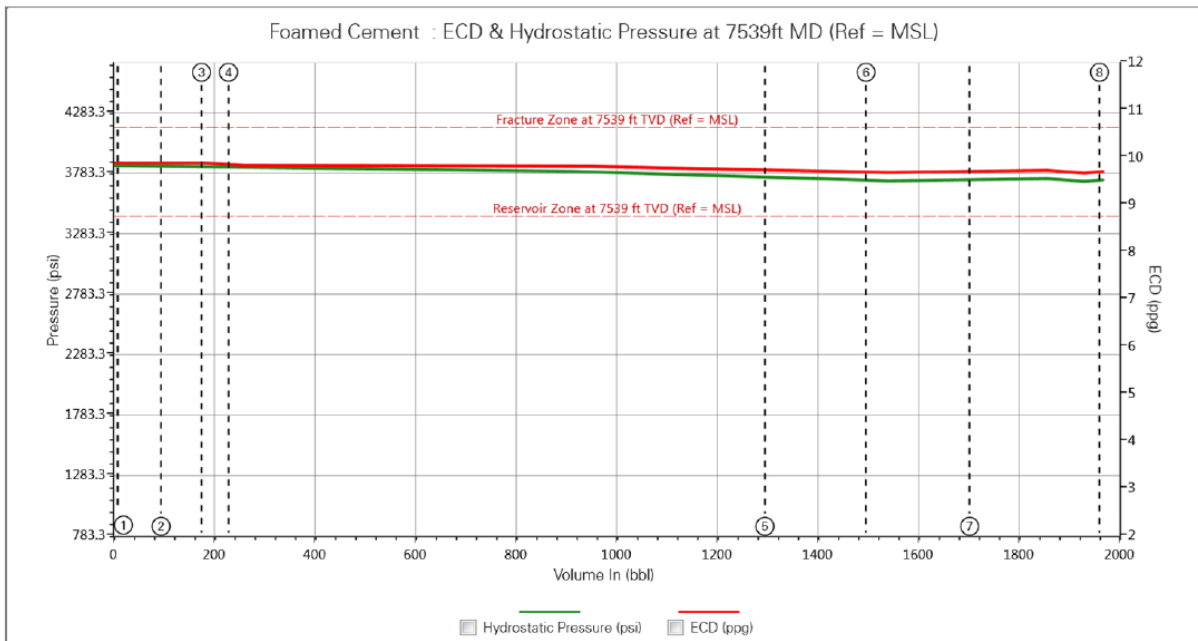

Cementing the 20 inches surface casing

Calculated surface Pressure Plot

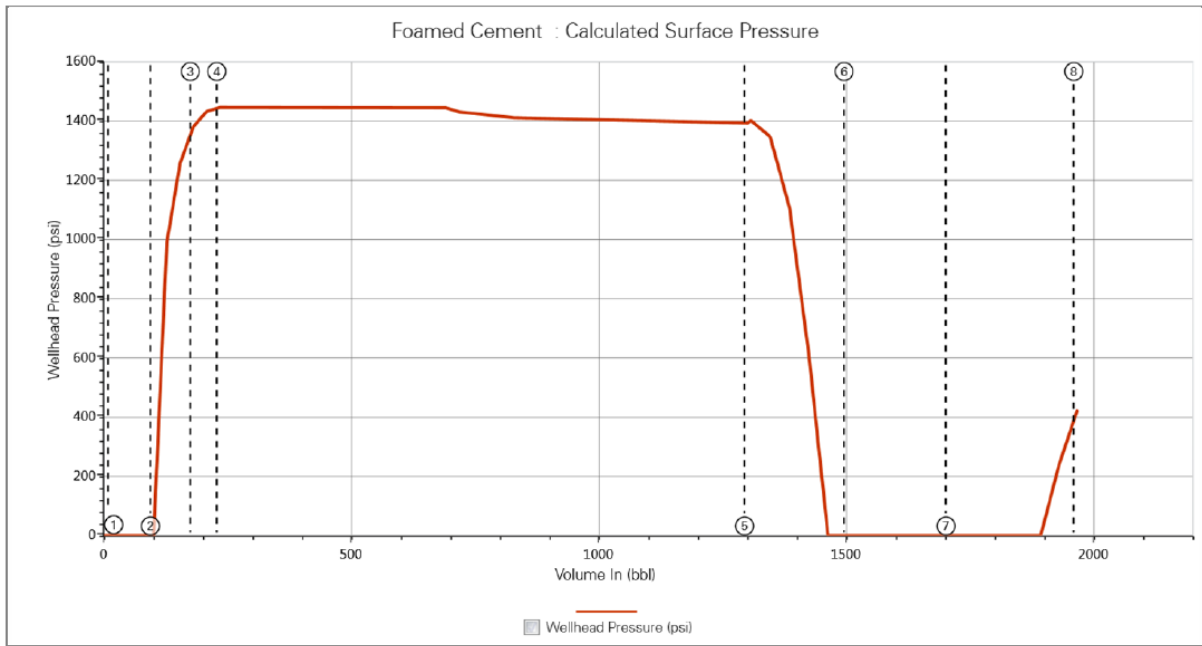

Hydraulics Summary

Flow Potential factor: 0

Reservoir Zone MD: 7637,8 ft

Flow Potential Plot

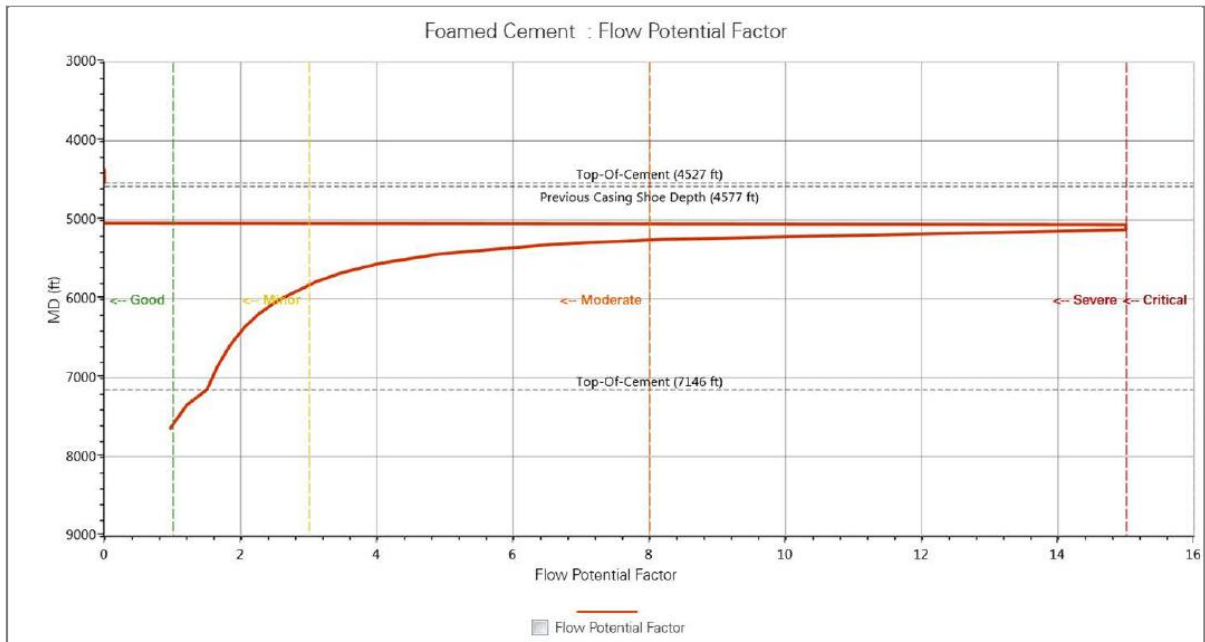

Cementing the 20 inches surface casing

Critical Static Gel Strength Plot

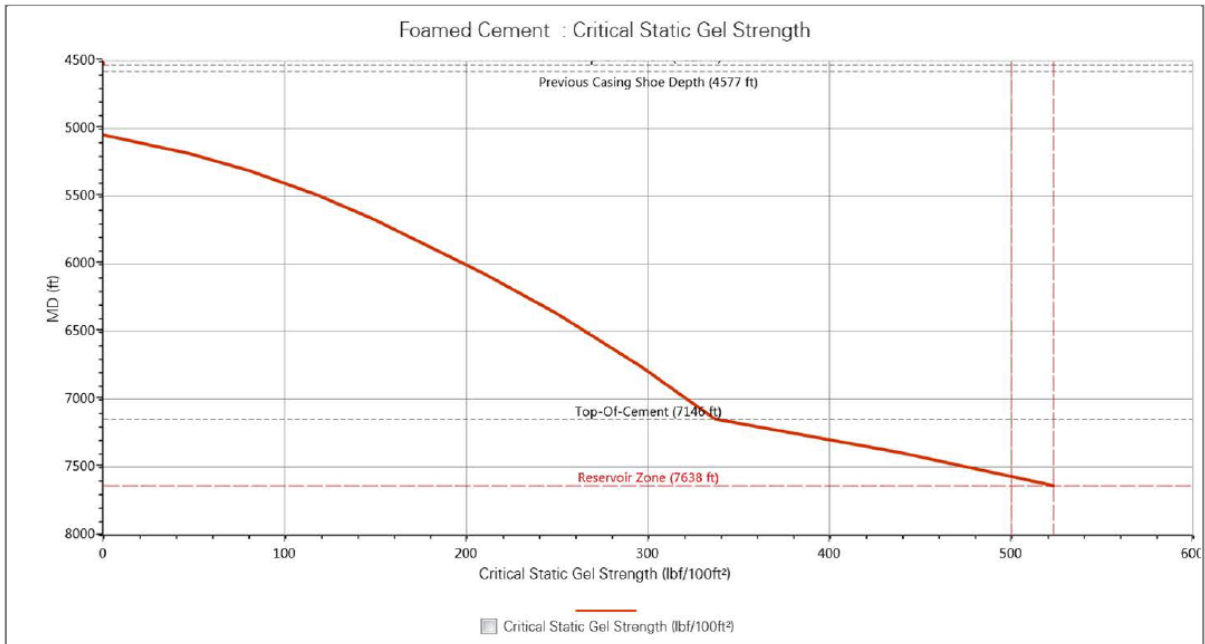

Downhole Pressure Profiles Plot

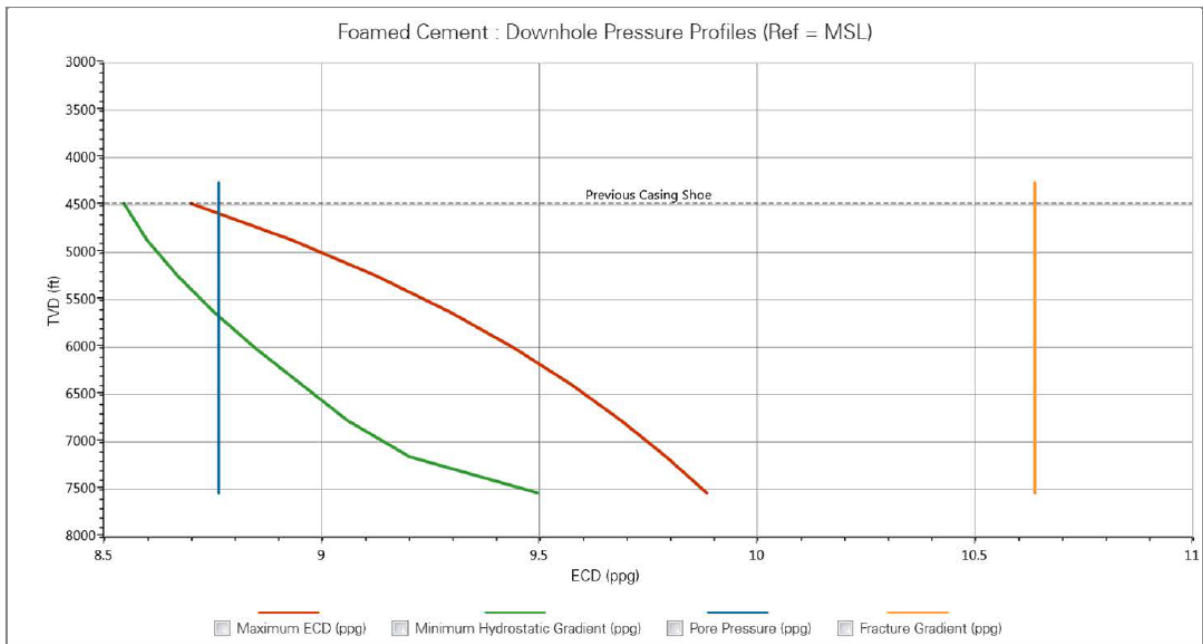

Cementing the 20 inches surface casing

Pure Fluid Rheology

Fluid Name	Rheology Model	Temp (°F)	τ_0 (YP) (lbf/100ft ²)	μ_{∞} (PV) (cp)	m	n	k
							lb*s ⁿ /ft ²
Angola-Pad Mud	Bingham Plastic	80,0	25,0	40	1,00	1,00	
Sea Water	Bingham Plastic	80,0	0,0	1,0	1,00	1,00	
Copy of Foamed Lead 2091464	Gen Herschel-Bulkley	80,0	27,4	245,3	1,00	1,00	
Copy of Foamed Lead 2091464	Gen Herschel-Bulkley	80,0	30,0	160,3	1,00	1,00	
Copy of Foamed Lead 2091464	Gen Herschel-Bulkley	71	45,0	197,1	1,00	1,00	
Angola-Lead Cement	Bingham Plastic	80,0	12,0	25,0	1,00	1,00	
Angola-Tail Cement	Bingham Plastic	80,0	28,0	18,0	1,00	1,00	
Sea Water	Bingham Plastic	80,0	0,0	1,0	1,00	1,00	

Rheological Hierarchy Plot at Reservoir Zone

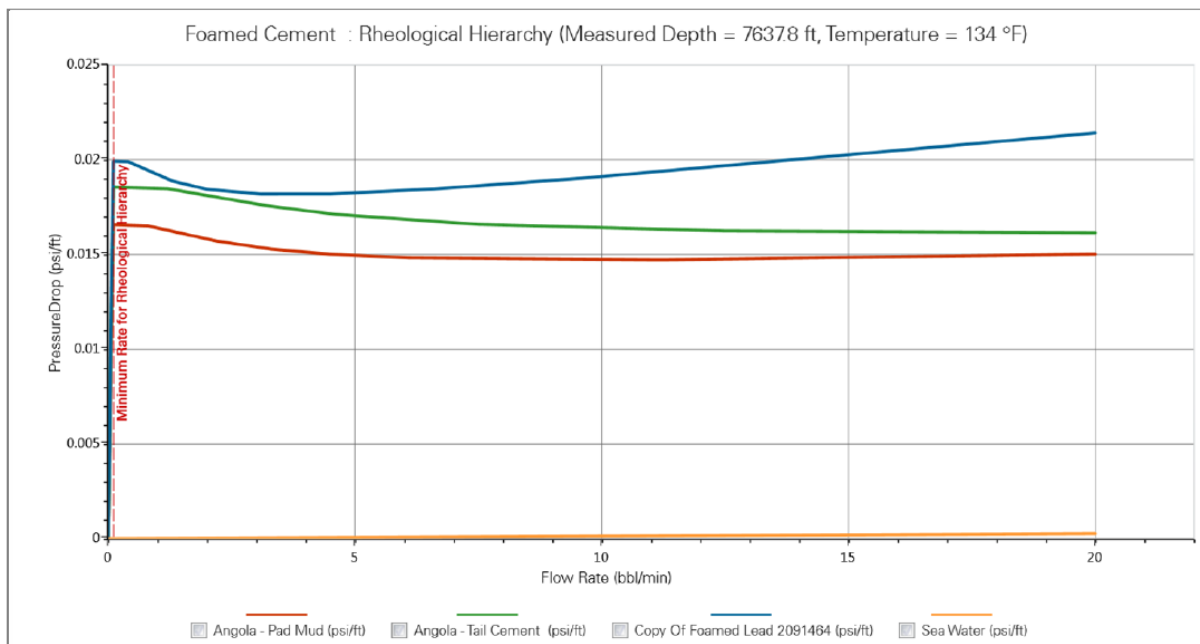

Cementing the 20 inches surface casing

Temperature Modeling

Beginning-job Temperature Profile Plot

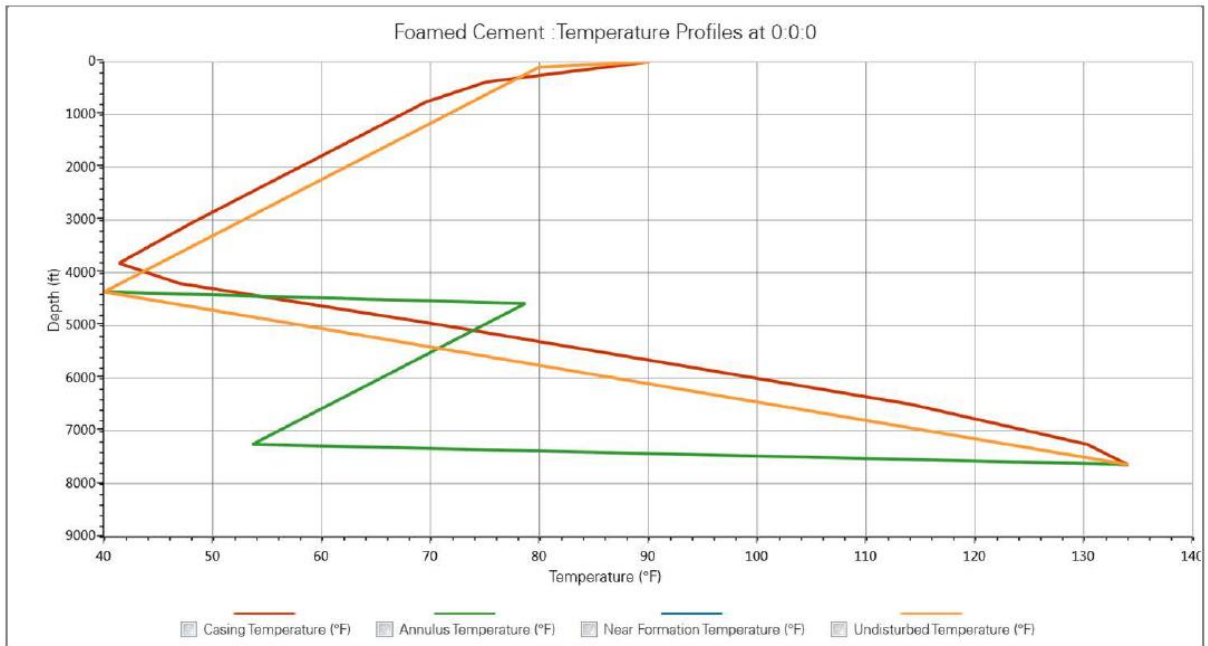

Slurry Placement Temperature Plot

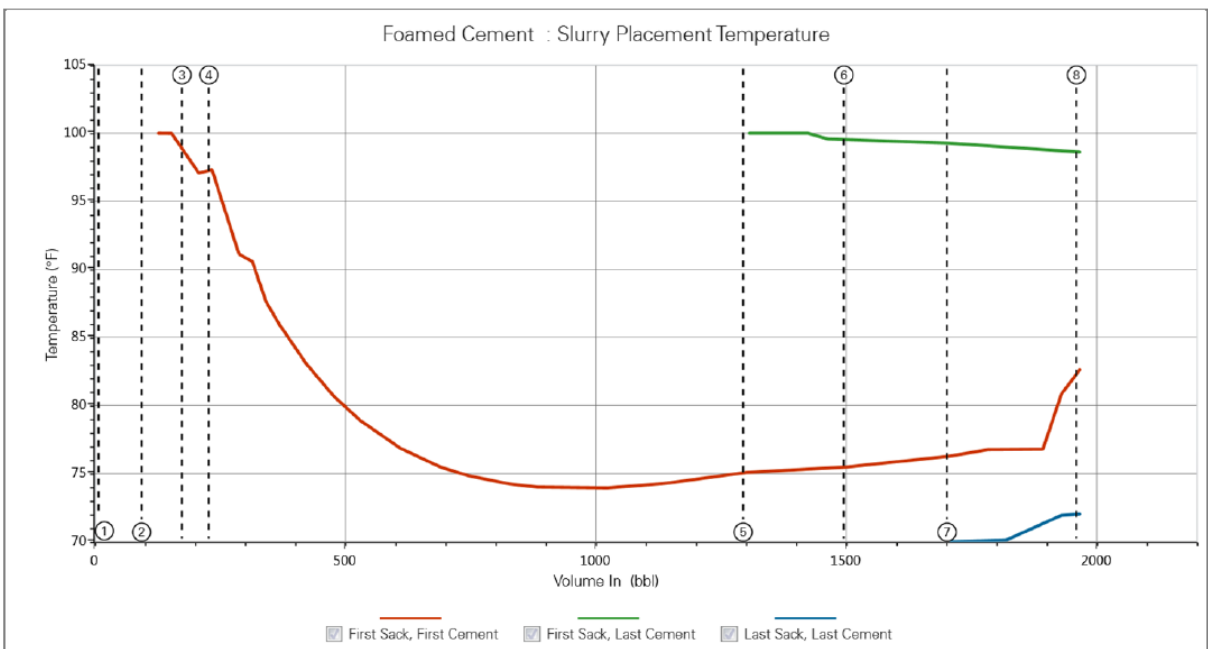

Cementing the 20 inches surface casing

Wait on Cement Plot

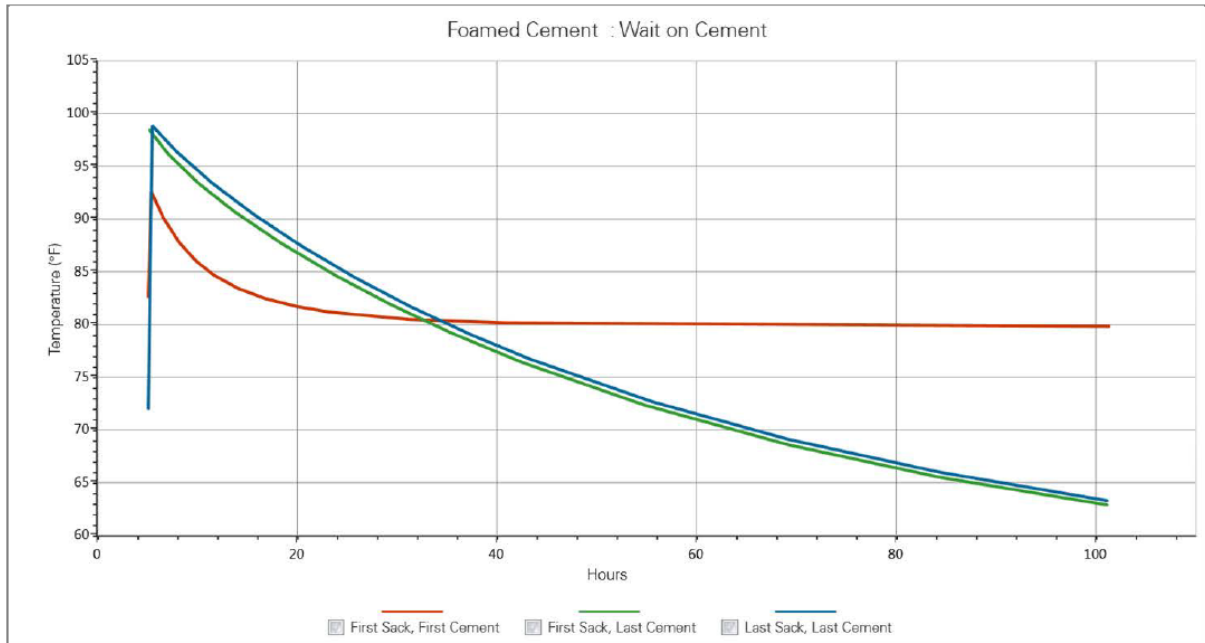

Mud Erodibility Profile Plot

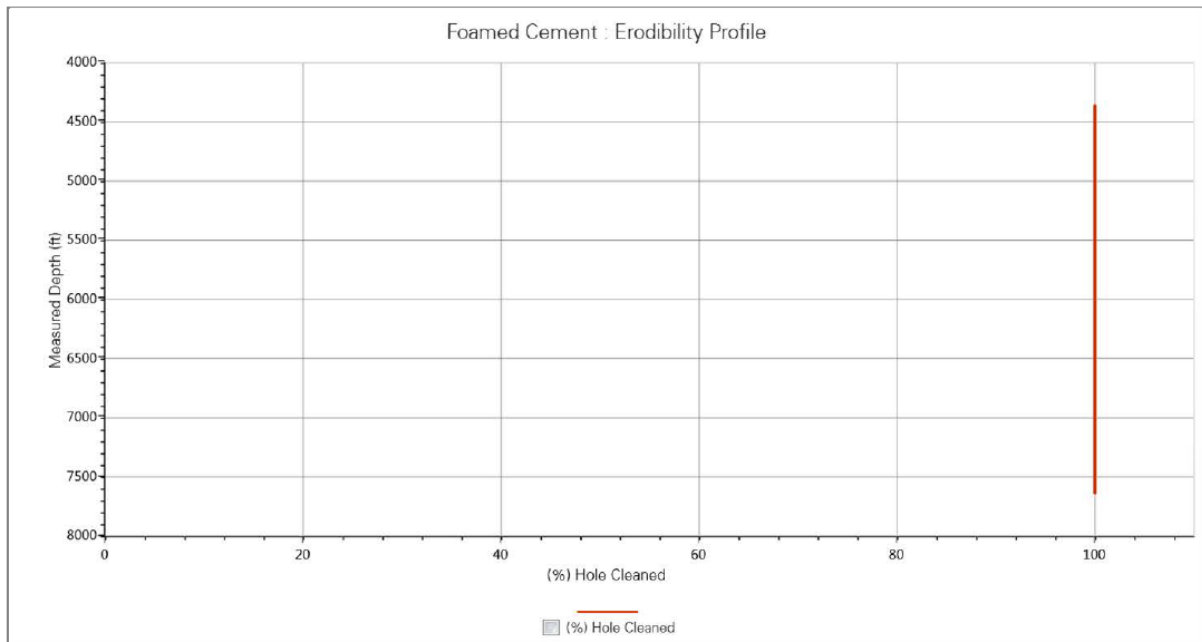

Cementing the 20 inches surface casing

Foam Design

Foam Design Parameter

Calculation Method: Constant or Staged Gas Flow

Surfactant: 1,50% bvow

Stabilizer: 0,00% bvow

Foam Pumping Schedule for liquids

Stage No.	Start Time (min)	Pump Rate (bbl/min)	Base Slurry vol.(bbl)	Cum.Base Slurry vol.(bbl)	Mix Water vol.(bbl)	Cum.Mix water vol.(bbl)	Foam Agents Rate(gpm)	Foam Agents vol.(gal)	Foam Agents Cum.job vol. (gal)
2	0	5	100	100			0	0	0
3	20	5	590,31	590,31	152,37	152,37	0,8	95,99	95,99
3	138,06	5	610,34	1200,66	157,54	309,91	0,8	95,5	195,24
4-1	260,13	31,45	395,84	395,84	251,51	251,51	0	0	195,24
4-2	272,72	31,45	11,18	407,02	7,10	258,61	0	0	195,24
5	273,07	8,00	258,23	258,23			0	0	194,24

Foam Pumping Schedule for Gas

Stage No.	Start Time (min)	Pump Rate (bbl/min)	Adj.Starting Gas Conc. (scf/bbl)	Adj.Ending Gas Conc. scf/bbl)	Starting Gas Rate (scfm)	Ending Gas Rate (scfm)	Cum.job Gas vol. (Mccf)	Expansion Factor
2	0	5					0	1
3	20	5	680,780	680,780	3404	3404	401,874	1,89
3	138,06	5	656,918	656,818	3285	3285	802,818	1,69
4-1	260,13	31,45					802,818	1
4-2	272,72	31,45					802,818	1
5	273,07	8					802,818	1

Foam Slurry Data

Description	Stage No.	Base Slurry Vol.(bbl)	Foam Slurry vol.(bbl)	Bulk Cement (94lbsacks)	Water Req. (gal/sack)	Yield (ft^3/sk)
Angola-Pad Mud	1	0,00	0,00			
Sea Water	2	100,00	100,00		0,000	0,0000
Copy of Foamed Lead 2091464	3	1200,66	2144,60	3092,28	4,209	2,1800
Angola-Tail Cement	4-1	395,84	395,84	1658,55	6,369	1,3400
Angola-Tail Cement	4-2	11,18	11,18	46,85	6,369	1,3400
Sea Water	5	258,23	258,23		0,000	0,0000

Cementing the 20 inches surface casing

Final Density & Hydrostatic Profile Plot

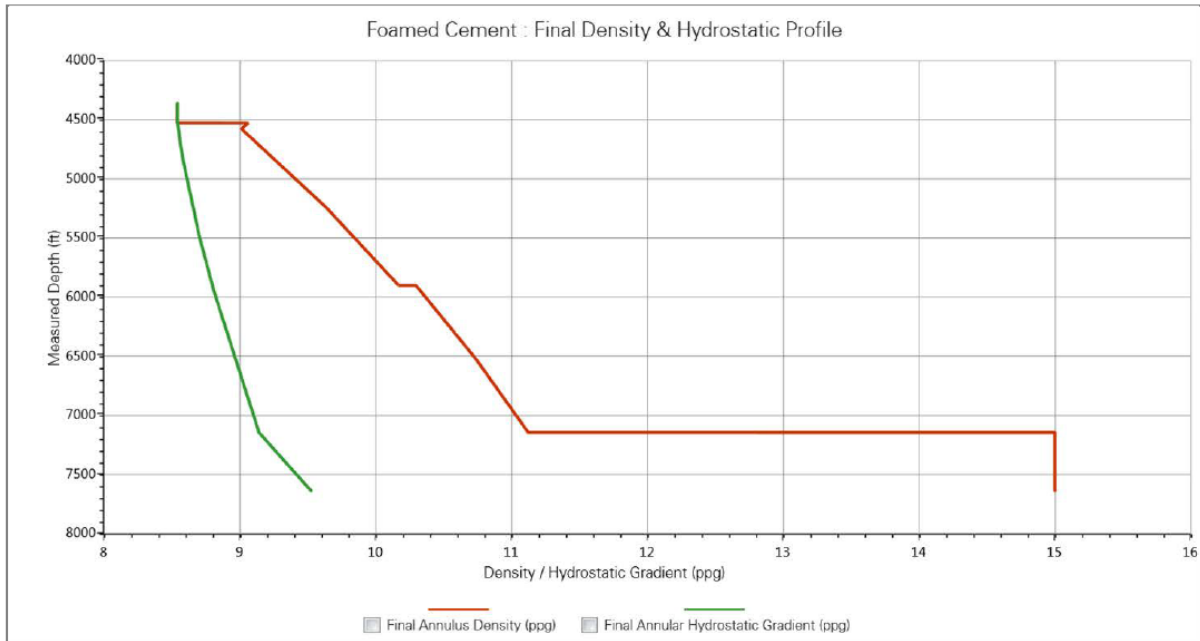

Standoff Profile Plot

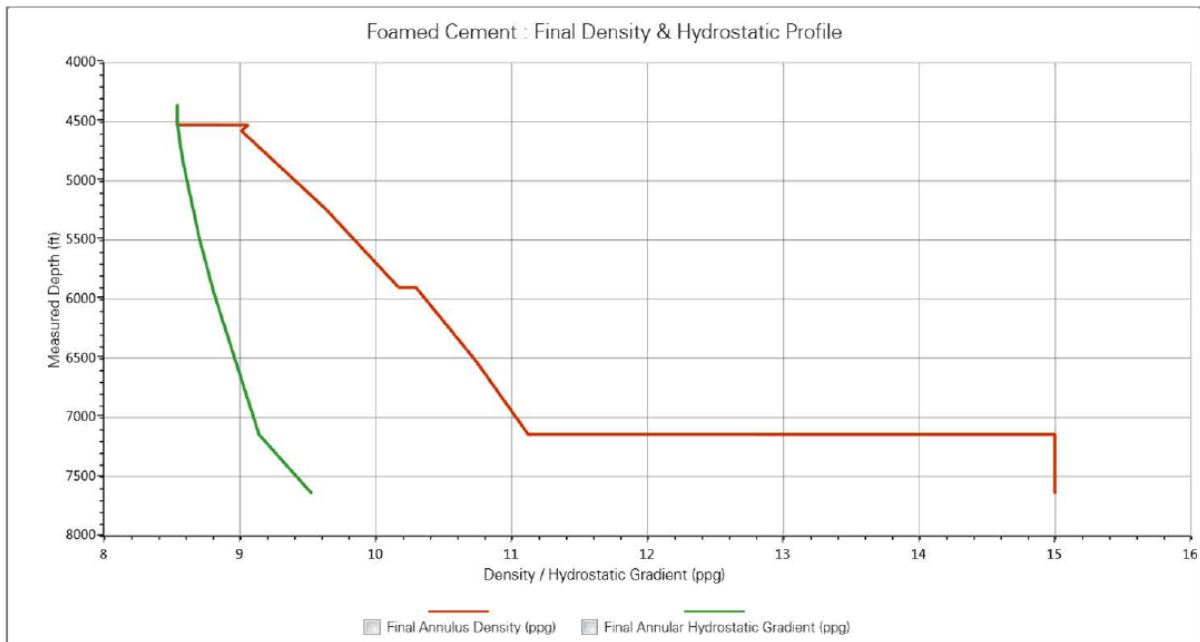

Cementing the 20 inches surface casing

5.2 Discussion

Analysing the results obtained from simulation of pump schedule, is clear that the benefits of using Foam cement are enormous, as we can see the volume, bulk cement and the time consuming are less than that spent in Lightweight Lead and Tail. Also the results show us that Foamed cement is indicated to avoid losses and to have returns on surface.

	Lightweight Lead & Tail	Foamed Cement
Volume (bbl)	2911,07	1965,91
Bulk Cement (94 bl sacks)	7361,68	4797,68
Time (min)	562,85	305,35

6. CONCLUSION

In order to be able of controlling the problems of non returns on surface while cementing 20" Surface Casing with Lightweight Lead and Tail in Chissonga Project, Foamed Cement is suitable to be used for following reasons:

- It requires less bulk storage capacity, takes few minutes and needs less volume of cement slurry than Lightweight Lead and Tail;
- Using a foamed Cement rather than Lightweight Lead and Tail slurry allow us to eliminate the concern of low fracture gradient due to low formation, mechanical strength, low reservoir pressure and lost circulation zones;
- Foamed Cement density is a function of the amount of nitrogen injected into the base slurry, so the density at which it is mixed can be selected immediately prior to the job. Additionally, by adjusting the gas ratio, the density can be changed during the job to provide slurries with different properties in different parts of the well. Conventional cement system are reformulated and tested in the laboratory, and then either re-blended or replaced by a completely different blend if slurry density has to be adjusted;
- Foamed Cement has been tested from Lab that it has strength at very low densities;
- To avoid common losses during cement jobs, particularly on 20" surface casing while running, circulating and cementing, Maersk Oil should use foamed cement instead of lightweight Lead and Tail in order to be able to reduce or to adjust the density of the Lead slurry to 11,50 pound per gallon and 15 ppg of Tail cement so that the space between annulus and casing can be filled and sealed perfectly.

REFERENCES

Adam, T.B.Jr., Keith, K.M., Martin, E.C. et al. 1986. Applied Drilling Engineering, SPE Textbook Series, vol.2. Richardson, Texas: Society of Petroleum Engineers.

Dwight, K.S. 1990. Cementing, second edition. Richardson, TX: SPE.

Erik, B. N and Dominique, G. 1990. Well Cementing, second edition. Sugar Land, Texas: Schlumberger.

Geoservices. 1993. Casing and Cementation, first edition. Le Blanc Mesnil: Geoservices Edition.

Gilles, G and Jean, P.N. 1999. Drilling data handbook, seventh edition. Paris: Technip.

Glen, B and David, P. 2005. Use of Foamed Cement in Deep Water Angola. Presented at the SPE/IADC Drilling Conference, Amsterdam, 23-25 February. SPE/IADC 91662

Huawen, G. 1993. Cement Evaluation Manual. Sunbury: BP.

Norton, J.L. 1992. Formulas and calculations for Drilling, Production and Workover. Houston: Gulf Publishing Company.

Robert, A. J and Glen, B. 1998. Advances in Metering and Control Technology Improved Design and Execution of Foamed Cement Jobs. Presented at IADC/SPE Asia Pacific Drilling Conference, Jakarta, 7-9 September. IADC/SPE 47831.

ANSI/API, Recommended Practice 10B-4, first edition. July 2010. Washington, DC: API.

API, Recommended Practice 10B-2, second edition. April 2013. Washington, DC: API.

Halliburton, iCem@Service 3D Simulator, June 17, 2014.

http://petrowiki.org/Cement_slurry_design. July 2014

APPENDIX A

Lightweight Lead & Tail and Foamed Cement.20 " Casing

Offshore

3D Wellbore Schematic

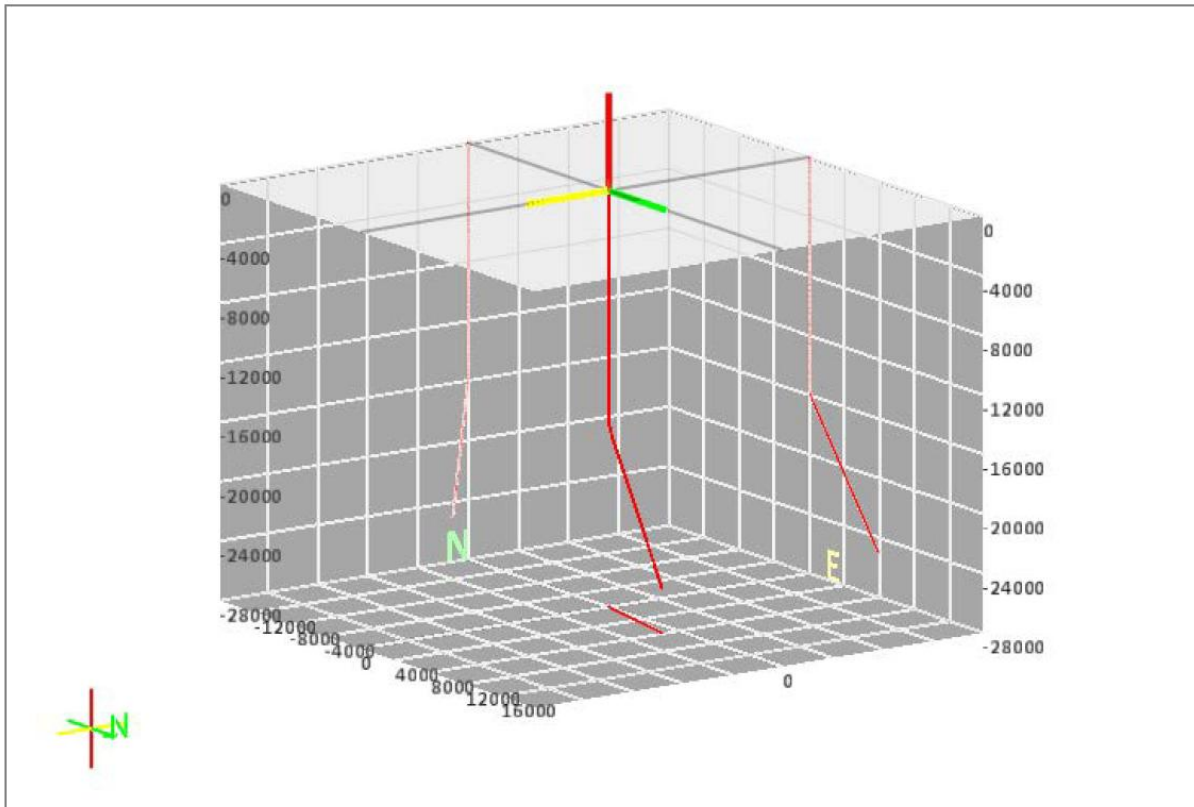

Cementing the 20 inches surface casing

Formation Definition Plot. Lightweight Lead & Tail and Foamed Cement

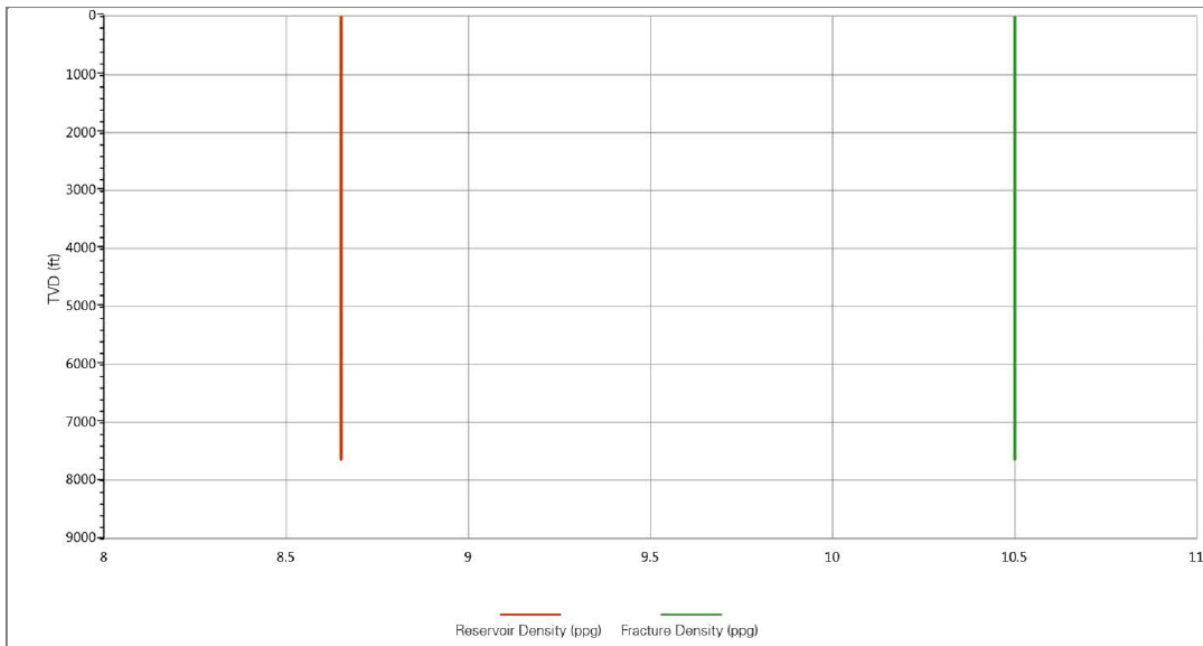

Wellbore Geometry- Surface Lines

Wellbore Geometry- Outer(Risers)

Wellbore Geometry- Outer(Casing/Liners)

Top MD (ft)	Bottom MD (ft)	Length (ft)	Contact Friction Factor	Outer Diameter (in)	Inner Diameter (ft)
4363,5	4576,8	211,25	0,25	36,000	28,000

Wellbore Geometry- Outer(Open Hole)

Top MD (ft)	Bottom MD (ft)	Length (ft)	Contact Friction Factor	Inner Diameter (in)	Annular Excess (%)
4575,8	7637,8	3061,02	0,30	26,000	200,00

Wellbore Geometry- Inner(Inner)

Type	Top MD (ft)	Bottom MD (ft)	Length (ft)	Outer Diameter (in)	Weight (ppf)	Grade	Inner Diameter (in)	Avg. Joint Length (ft)
Cas	4363,5	7637,8	3274,28	20,000	133,00		18,730	42,0
DP	0,0	4363,5	4363,52	6,625	40,70		5,675	33,0

Wellbore Geometry- Inner(Inner String)

Type	Top MD (ft)	Bottom MD (ft)	Length (ft)	Outer Diameter (in)	Weight (ppg)	Grade	Inner Diameter (in)	Avg. Joint Length (ft)
DP	4363,5	7539,4	3175,9	6,625	40,70		5,675	33,0

20" Casing
Lightweight Lead-Tail and
Foamed Cement

Cementing the 20 inches surface casing

Job Summary at Reservoir Zone. Lightweight Lead & Tail

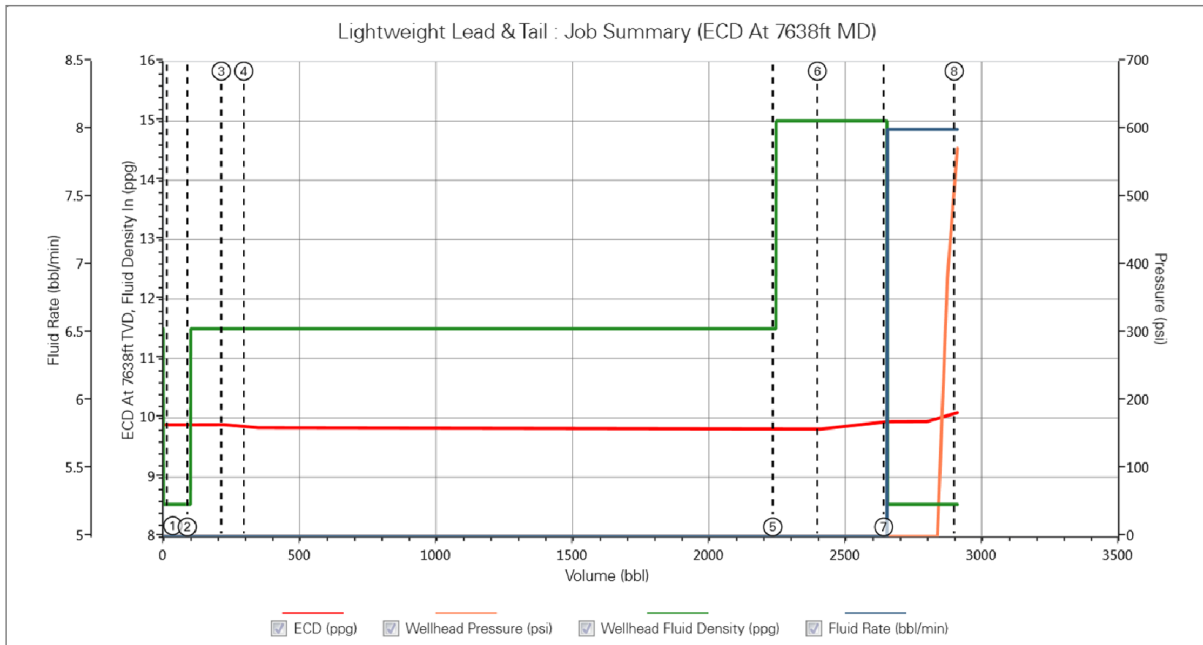

Job Summary at Reservoir Zone. Foamed Cement

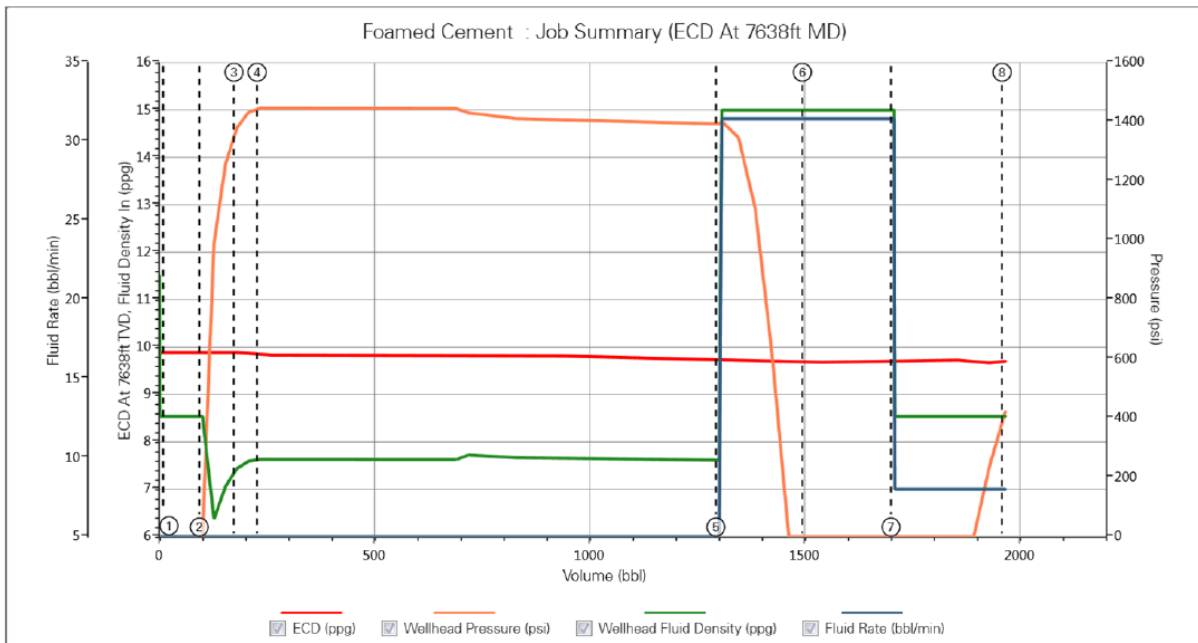

Cementing the 20 inches surface casing

Comparison of Rates In & Out Plot. Lightweight Lead & Tail

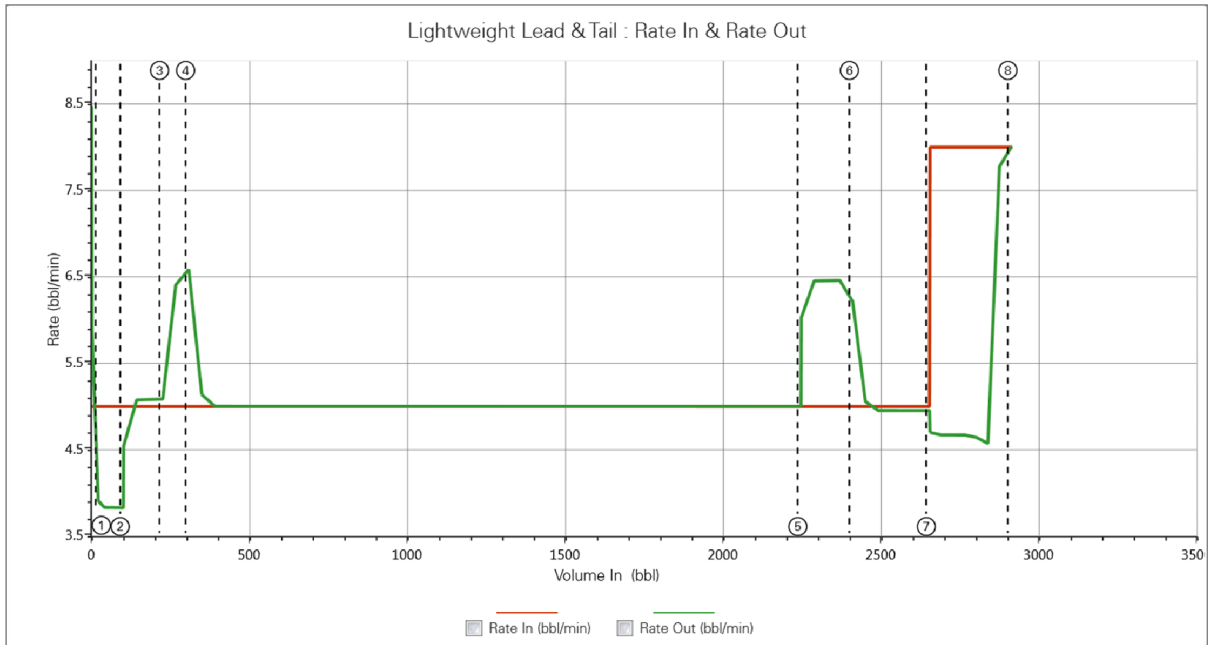

Comparison of Rates In & Out Plot. Foamed Cement

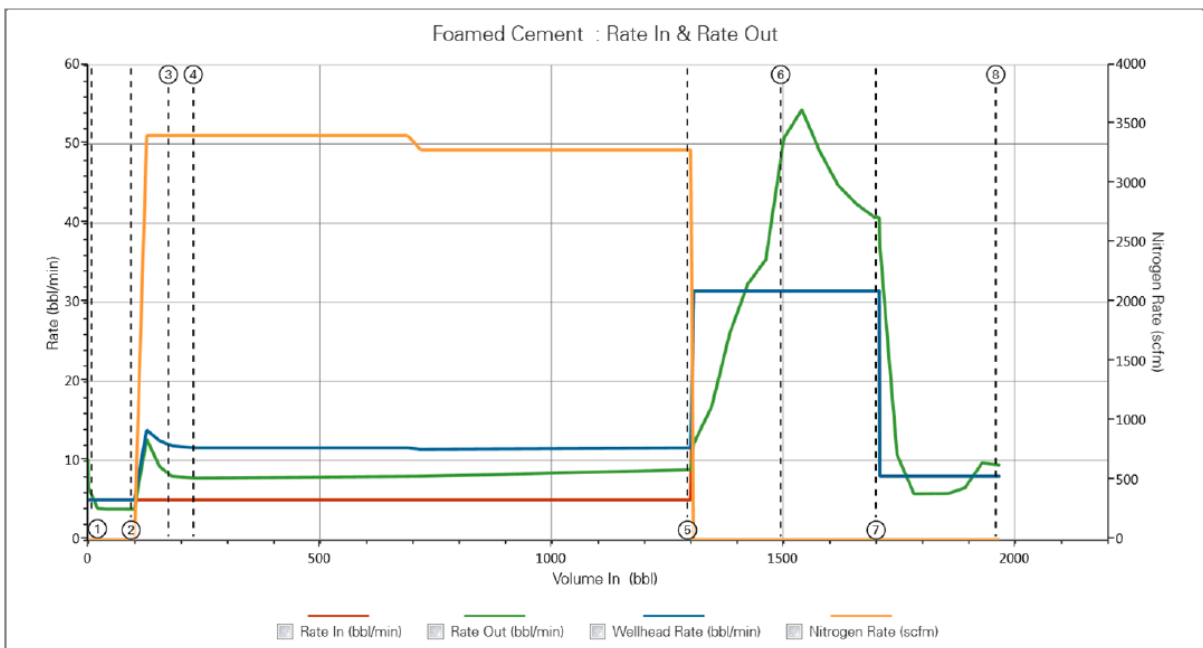

Cementing the 20 inches surface casing

Critical Velocity

Lightweight Lead and Tail, 20" Csg

Fluid Name	Reservoir Zone at 7637,8 ft			Fracture Zone at 7637,8ft		
	Critical Rate (bbl/min)	Critical Velocity (ft/s)	Reynold's Number	Critical Rate (bbl/min)	Critical Velocity ft/s	Reynold's Numbe
Pd Mud	332,00	6,879	4456,6	332,00	6,879	4456,4
Sea Water	2,96	0,061	3785,0	2,96	0,061	3785,0
Lead Cemt	229,59	4,757	4512,3	229,59	4,757	4512,3
Tail Cemt	310,58	6,437	5054,2	310,68	6,437	5054,2
Sea Water	2,96	0,061	3785,0	2,96	0,061	3785,0

Foam Cement. 20" Csg

Fluid Name	Reservoir Zone at 7637,8 ft			Fracture Zone at 7637,8ft		
	Critical Rate (bbl/min)	Critical Velocity (ft/s)	Reynold's Number	Critical Rate (bbl/min)	Critical Velocity ft/s	Reynold's Numbe
Angola- Pd Mud	332,00	6,879	4456,6	332,00	6,879	4456,4
Sea Water	2,96	0,061	3785,0	2,96	0,061	3785,0
Copy of Foamed Lead 2091464	335,31	6,948	3925,7	335,31	6,948	3925,7
Angola-Tail Cement	310,58	6,437	5054,2	310,68	6,437	5054,2
Sea Water	2,96	0,061	3785,0	2,96	0,061	3785,0

Pure Fluid Viscometer Data

Fluid Name	Temp (F)	600	300	200	100	60	30	20	10	6	6D	3	3D
Angola-Pad Mud	80,0												
Sea Water	80,0												
Copy of Foamed Lead 2091464	80,0	82	45	38	28	26	22			22	16	20	17
Copy of Foamed Lead 2091464	80,0	340	200	146	86	64	42			24		20	
Copy of Foamed Lead 2091464	71,0	416	264	198	122	90	62			26		20	
Angola-Tail Cement	80,0												
Sea Water	80,0												

Cementing the 20 inches surface casing

Pressure to Break Circulation Plot. Lightweight Lead & Tail and Foamed Cement

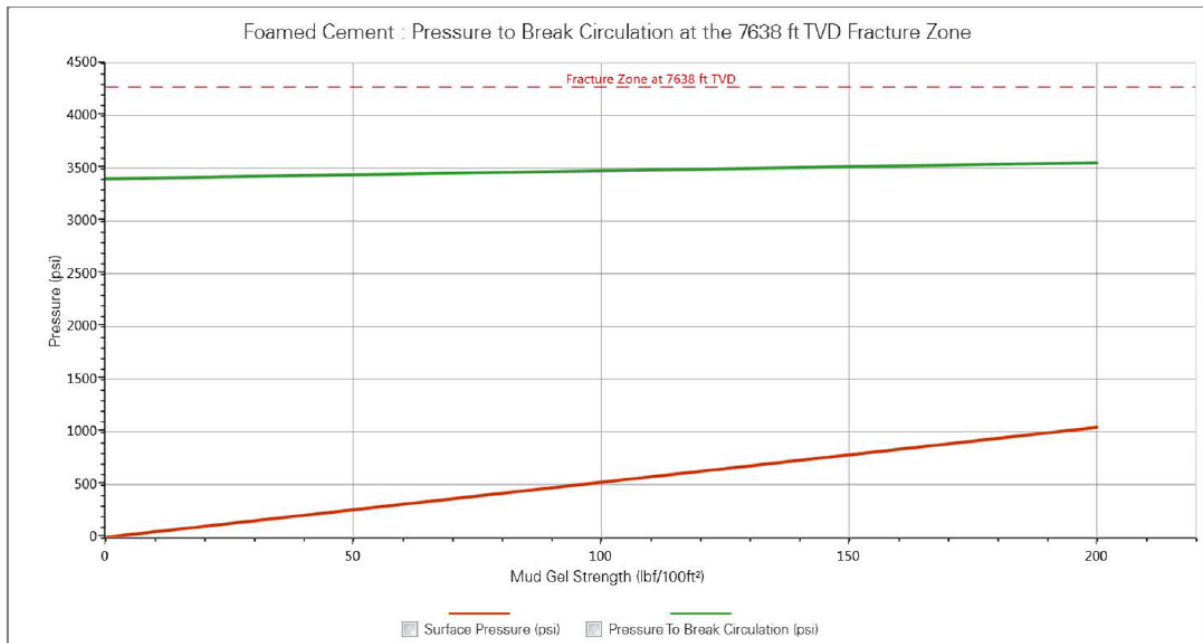

Final annular Fluid Density. Lightweight Lead & Tail

Measured Depth (ft)	Density (ppg)	Foam Quality (%)	Hydrostatic Gradient (psi/ft)
4,363.5	8.54	0.00	0.444
4,476.8	11.50	0.00	0.448
4,633.0	11.50	0.00	0.453
4,735.5	11.50	0.00	0.456
4,889.4	11.50	0.00	0.461
5,043.2	11.50	0.00	0.465
5,197.0	11.50	0.00	0.469
5,350.9	11.50	0.00	0.473
5,504.7	11.50	0.00	0.476
5,658.6	11.50	0.00	0.479
5,812.4	11.50	0.00	0.483
5,966.2	11.50	0.00	0.486
6,120.1	11.50	0.00	0.488
6,273.9	11.50	0.00	0.491
6,427.8	11.50	0.00	0.494
6,581.6	11.50	0.00	0.496
6,735.4	11.50	0.00	0.499
6,889.3	11.50	0.00	0.501
7,043.1	11.50	0.00	0.503
7,146.9	15.00	0.00	0.504
7,298.3	15.00	0.00	0.510
7,449.8	15.00	0.00	0.516
7,550.7	15.00	0.00	0.519
7,637.5	15.00	0.00	0.522

Cementing the 20 inches surface casing

Centralizer Placement calculations. Lightweight Lead & Tail

Measured Depth (ft)	Deviation (°)	Azimuth (°)	Restoring Force (lbf)	Standoff at Centralizer (%)	Standoff Between Centralizer (%)
4,659.8	0.0	0.0	0	43.2	43.2
4,701.8	0.0	0.0	0	43.2	43.2
4,743.8	0.0	0.0	0	43.2	43.2
4,785.8	0.0	0.0	0	43.2	43.2
4,827.8	0.0	0.0	0	43.2	43.2
4,869.8	0.0	0.0	0	43.2	43.2
4,911.8	0.0	0.0	0	43.2	43.2
4,953.8	0.0	0.0	0	43.2	43.2
4,995.8	0.0	0.0	0	43.2	43.2
5,037.8	0.0	0.0	0	43.2	43.2
5,079.8	0.0	0.0	0	43.2	43.2
5,121.8	0.0	0.0	0	43.2	43.2
5,163.8	0.0	0.0	0	43.2	43.2
5,205.8	0.0	0.0	0	43.2	43.2
5,247.8	0.0	0.0	0	43.2	43.2
5,289.8	0.0	0.0	0	43.2	43.2
5,331.8	0.0	0.0	0	43.2	43.2
5,373.8	0.0	0.0	0	43.2	43.2
5,415.8	0.0	0.0	0	43.2	43.2
5,457.8	0.0	0.0	0	43.2	43.2
5,499.8	0.0	0.0	0	43.2	43.2
5,541.8	0.0	0.0	0	43.2	43.2
5,583.8	0.0	0.0	0	43.2	43.2
5,625.8	0.0	0.0	0	43.2	43.2
5,667.8	0.0	0.0	0	43.2	43.2
5,709.8	0.0	0.0	0	43.2	43.2
5,751.8	0.0	0.0	0	43.2	43.2
5,793.8	0.0	0.0	0	43.2	43.2
5,835.8	0.0	0.0	0	43.2	43.2
5,877.8	0.0	0.0	0	43.2	43.2
5,919.8	0.0	0.0	0	43.2	43.2
5,961.8	0.0	0.0	0	43.2	43.2
6,003.8	0.0	0.0	0	43.2	43.2
6,045.8	0.0	0.0	0	43.2	43.2
6,087.8	0.0	0.0	0	43.2	43.2
Measured Depth (ft)	Deviation (°)	Azimuth (°)	Restoring Force (lbf)	Standoff at Centralizer (%)	Standoff Between Centralizer (%)
6,129.8	0.0	0.0	0	43.2	43.2
6,171.8	0.0	0.0	0	43.2	43.2
6,213.8	0.0	0.0	0	43.2	43.2
6,255.8	0.0	0.0	0	43.2	43.2
6,297.8	0.0	0.0	0	43.2	43.2
6,339.8	0.0	0.0	0	43.2	43.2
6,381.8	0.0	0.0	0	43.2	43.2
6,423.8	0.0	0.0	0	43.2	43.2
6,465.8	0.0	0.0	0	43.2	43.2
6,507.8	0.0	0.0	0	43.2	43.2

Cementing the 20 inches surface casing

6,549.8	0.0	0.0	0	43.2	43.2
6,591.8	0.0	0.0	0	43.2	43.2
6,633.8	0.0	0.0	0	43.2	43.2
6,675.8	0.0	0.0	0	43.2	43.2
6,717.8	0.0	0.0	0	43.2	43.2
6,759.8	0.0	0.0	0	43.2	43.2
6,801.8	0.0	0.0	0	43.2	43.2
6,843.8	0.0	0.0	0	43.2	43.2
6,885.8	0.0	0.0	0	43.2	43.2
6,927.8	0.0	0.0	0	43.2	43.2
6,969.8	0.0	0.0	0	43.2	43.2
7,011.8	0.0	0.0	0	43.2	43.2
7,053.8	0.0	0.0	0	43.2	43.2
7,070.8	0.0	0.0	0	43.2	43.2
7,091.8	0.0	0.0	0	43.2	43.2
7,112.8	0.0	0.0	0	43.2	43.2
7,133.8	0.0	0.0	0	43.2	43.2
7,154.8	0.0	0.0	0	43.2	43.2
7,175.8	0.0	0.0	0	43.2	43.2
7,196.8	0.0	0.0	0	43.2	43.2
7,217.8	0.0	0.0	0	43.2	43.2
7,238.8	0.0	0.0	0	43.2	43.2
7,259.8	0.0	0.0	0	43.2	43.2
7,280.8	0.0	0.0	0	43.2	43.2
7,301.8	0.0	0.0	0	43.2	43.2
7,322.8	0.0	0.0	0	43.2	43.2
Measured Depth (ft)	Deviation (°)	Azimuth (°)	Restoring Force (lbf)	Standoff at Centralizer (%)	Standoff Between Centralizer (%)
7,343.8	0.0	0.0	0	43.2	43.2
7,364.8	0.0	0.0	0	43.2	43.2
7,385.8	0.0	0.0	0	43.2	43.2
7,406.8	0.0	0.0	0	43.2	43.2
7,427.8	0.0	0.0	0	43.2	43.2
7,448.8	0.0	0.0	0	43.2	43.2
7,469.8	0.0	0.0	0	43.2	43.2
7,490.8	0.0	0.0	0	43.2	43.2
7,511.8	0.0	0.0	0	43.2	43.2
7,532.8	0.0	0.0	0	43.2	43.2
7,553.8	0.0	0.0	0	43.2	43.2
7,574.8	0.0	0.0	0	43.2	43.2
7,595.8	0.0	0.0	0	43.2	43.2
7,616.8	0.0	0.0	0	43.2	43.2
7,637.8	0.0	0.0	0	43.2	43.2

Cementing the 20 inches surface casing

Hook Load Plot. Lightweight Lead & Tail

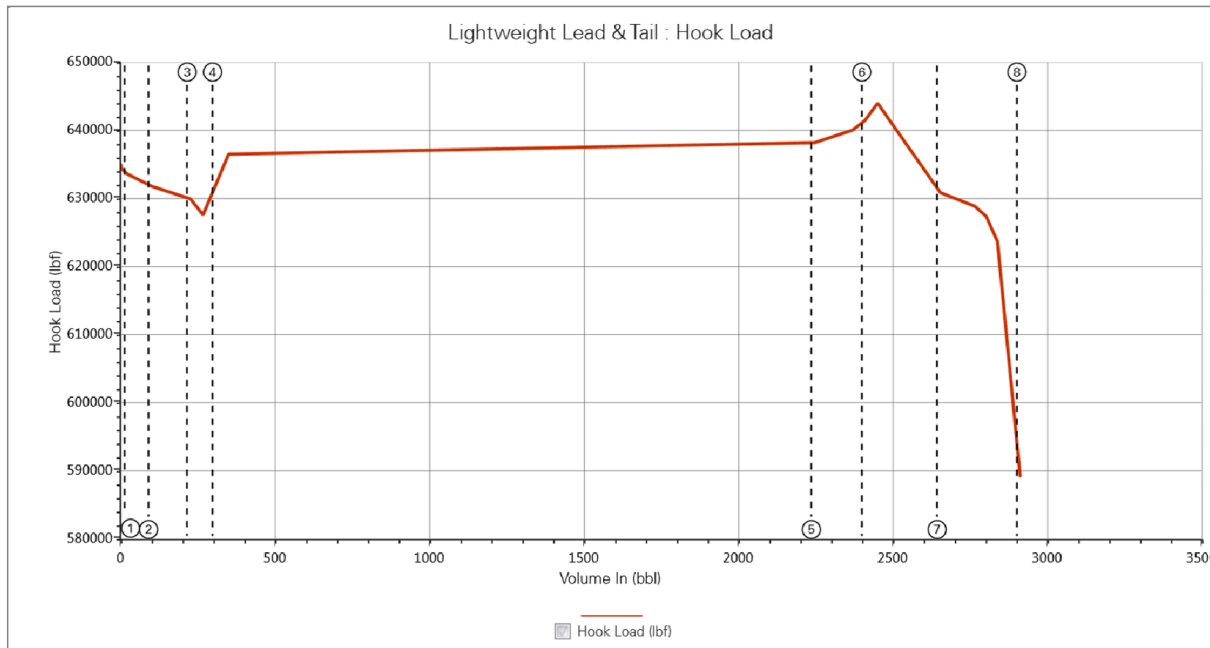

Horsepower, Pressure and Freefall Lightweight Lead & Tail

(mins)	Liquid Volume In (bbl)	Pump Output (hp)	Surface Pressure In (psi)	Surface Pressure Out (psi)	ECD @ Frac Zone (ppg)	Free Fall Height (ft)
0.00	0.0	0.00	0.00	1,892.15	9.75	921.29
12.08	60.4	1.80	0.00	1,892.24	9.76	492.59
28.45	142.2	1.80	0.00	1,892.15	9.76	213.36
61.45	307.2	1.80	0.00	1,892.15	9.72	1,048.23
94.44	472.2	1.80	0.00	1,892.15	9.70	1,085.99
127.44	637.2	1.80	0.00	1,892.15	9.70	1,087.19
160.44	802.2	1.80	0.00	1,892.15	9.70	1,088.39
193.44	967.2	1.80	0.00	1,892.15	9.70	1,089.59
226.43	1,132.2	1.80	0.00	1,892.15	9.70	1,090.79
259.43	1,297.1	1.80	0.00	1,892.15	9.70	1,091.99
292.43	1,462.1	1.80	0.00	1,892.15	9.69	1,093.19
325.42	1,627.1	1.80	0.00	1,892.15	9.69	1,094.40
358.42	1,792.1	1.80	0.00	1,892.15	9.69	1,095.60
391.42	1,957.1	1.80	0.00	1,892.15	9.69	1,096.80
424.42	2,122.1	1.80	0.00	1,892.15	9.69	1,098.00
449.36	2,246.8	1.80	0.00	1,892.15	9.68	1,105.18
481.85	2,409.2	1.80	0.00	1,892.15	9.68	2,555.74
514.33	2,571.6	1.80	0.00	1,892.15	9.76	2,534.77
535.35	2,691.1	2.88	0.00	1,892.13	9.81	2,001.97
553.68	2,837.7	2.88	0.00	1,892.17	9.84	32.71

Cementing the 20 inches surface casing

Final Annular Fluid Density. Foamed Density

Measured Depth (ft)	Density (ppg)	Foam Quality (%)	Hydrostatic Gradient (psi/ft)
4,363.5	8.54	0.00	0.444
4,473.7	8.54	0.00	0.444
4,576.8	9.01	0.49	0.444
4,683.4	9.12	0.49	0.445
4,811.8	9.24	0.48	0.445
5,000.4	9.42	0.47	0.447
5,124.8	9.53	0.46	0.448
5,308.0	9.69	0.45	0.450
5,429.1	9.79	0.45	0.451
5,607.6	9.94	0.44	0.453
5,725.8	10.03	0.43	0.455
5,900.2	10.17	0.43	0.457
6,017.9	10.38	0.41	0.459
6,191.9	10.51	0.41	0.461
6,307.3	10.59	0.40	0.463
6,478.0	10.71	0.39	0.465
6,591.3	10.78	0.39	0.467
6,759.1	10.89	0.38	0.469
6,870.6	10.96	0.38	0.471
7,035.8	11.06	0.37	0.473
7,145.7	15.00	0.00	0.475
7,250.0	15.00	0.00	0.479
7,347.2	15.00	0.00	0.483
7,492.2	15.00	0.00	0.489
7,540.9	15.00	0.00	0.491
7,637.5	15.00	0.00	0.495

Hook Load Plot. Foamed Cement

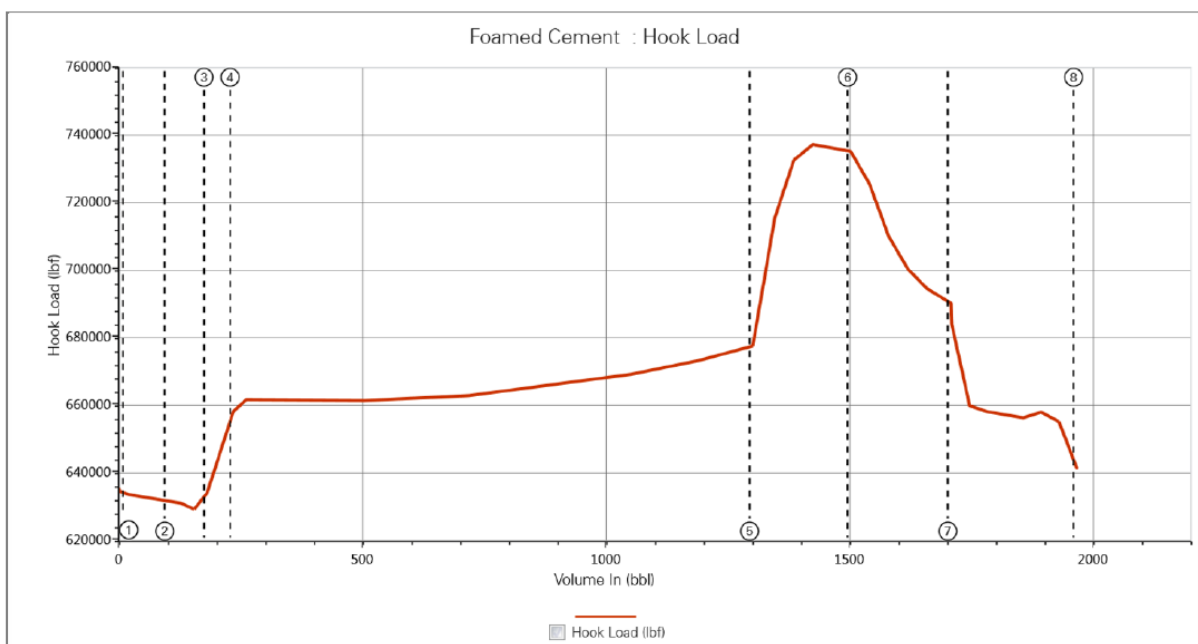

Cementing the 20 inches surface casing

Horsepower, Pressure and Freefall. Foamed Cement

Time (mins)	Liquid Volume In (bbl)	Pump Output (hp)	Surface Pressure In (psi)	Surface Pressure Out (psi)	ECD @ Frac Zone (ppg)	Free Fall Height (ft)
0.00	0.0	0.00	0.00	1,892.15	9.75	913.10
8.12	40.6	1.80	0.00	1,892.20	9.76	640.71
20.00	100.0	1.80	0.00	1,892.30	9.76	196.31
36.10	180.5	170.98	1,381.66	1,891.64	9.75	0.00
52.20	261.0	178.65	1,444.30	1,892.04	9.71	0.00
68.30	341.5	178.65	1,444.30	1,891.34	9.71	0.00
84.40	422.0	178.71	1,444.78	1,891.39	9.71	0.00
100.50	502.5	178.77	1,445.20	1,891.95	9.71	0.00
116.60	583.0	178.77	1,445.20	1,892.27	9.71	0.00
132.70	663.5	178.70	1,444.69	1,892.17	9.71	0.00
149.16	745.8	176.19	1,424.16	1,892.56	9.70	0.00
165.81	829.0	174.57	1,410.93	1,892.32	9.70	0.00
182.45	912.3	174.29	1,408.66	1,892.19	9.69	0.00
199.10	995.5	174.04	1,406.64	1,892.22	9.68	0.00
215.74	1,078.7	173.72	1,404.02	1,892.27	9.66	0.00
232.39	1,161.9	173.32	1,400.71	1,892.34	9.64	0.00
249.03	1,245.2	172.82	1,396.63	1,892.43	9.62	0.00
260.33	1,306.9	1,091.03	1,401.88	1,891.24	9.60	0.00
264.05	1,423.8	486.36	616.79	1,892.15	9.58	0.00
267.76	1,540.7	11.32	0.00	1,892.02	9.55	1,083.33
271.48	1,657.5	11.32	0.00	1,891.99	9.57	1,790.17
272.86	1,701.0	11.32	0.00	1,891.93	9.58	1,867.30
273.07	1,707.7	11.32	0.00	1,891.94	9.58	1,877.27
282.44	1,782.6	2.88	0.00	1,892.15	9.59	1,624.35
296.19	1,892.6	2.88	0.00	1,892.15	9.58	168.11
305.35	1,965.9	85.32	420.80	1,892.40	9.57	0.00

Cementing the 20 inches surface casing

APPENDIX B

Lightweight Lead & Tail & Weighted Spacer. 20" Casing

Offshore

Rheological Hierarchy Plot at Reservoir Zone

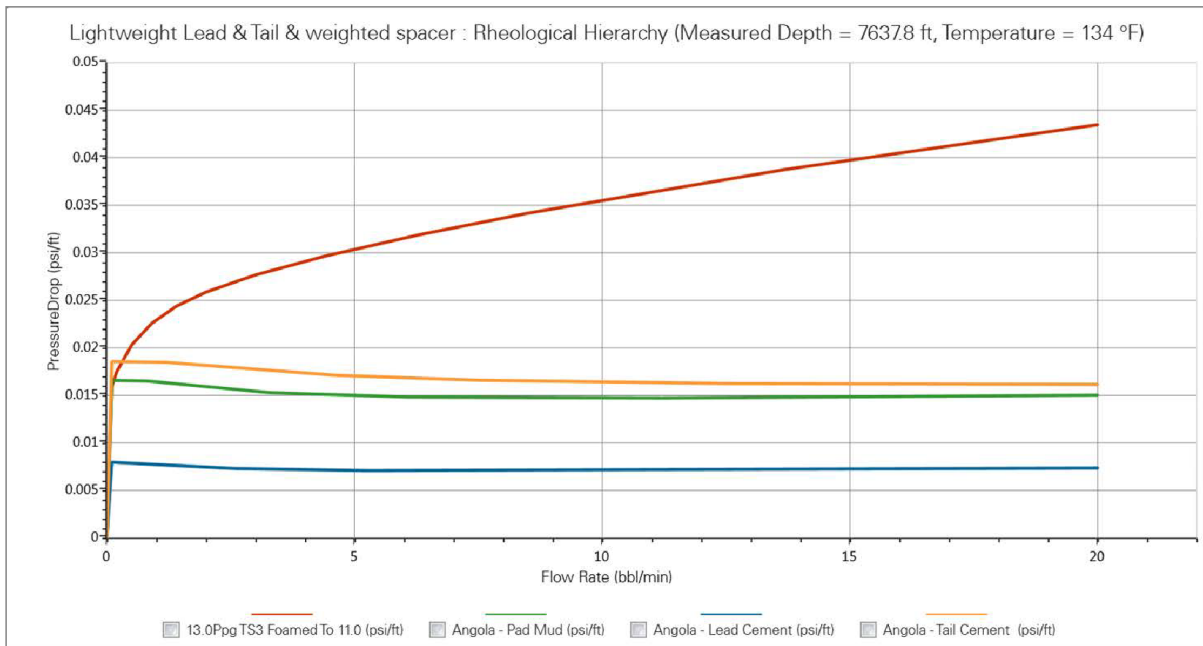

Slurry Placement Temperature Plot

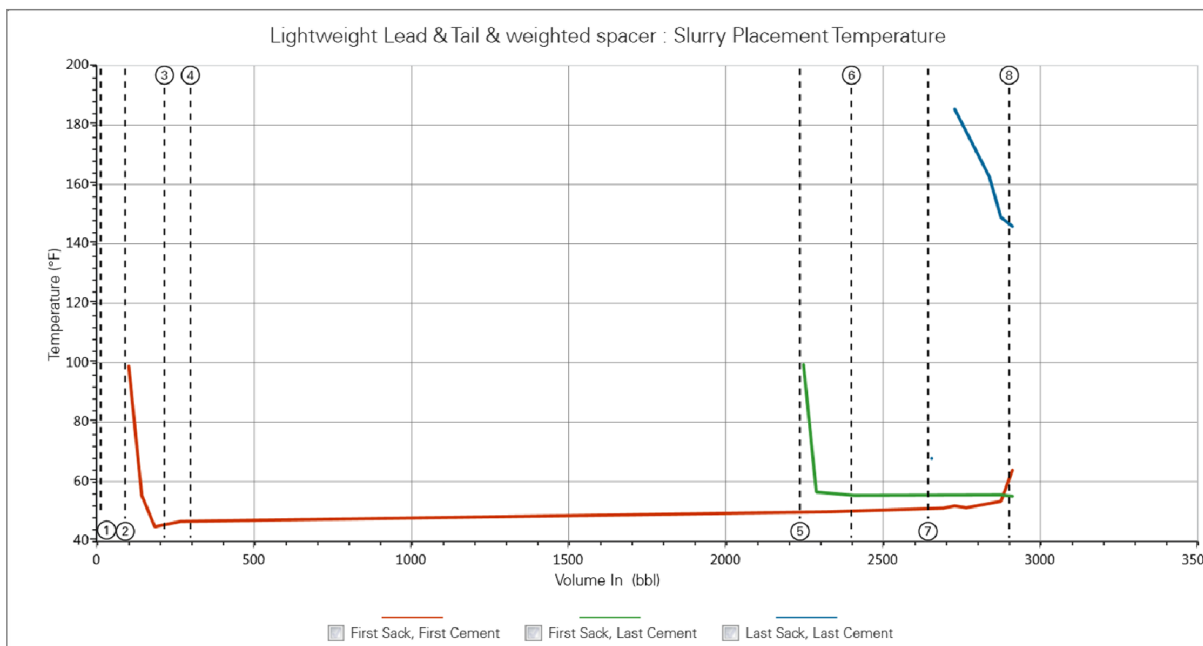

Cementing the 20 inches surface casing

Wait on Cement Plot

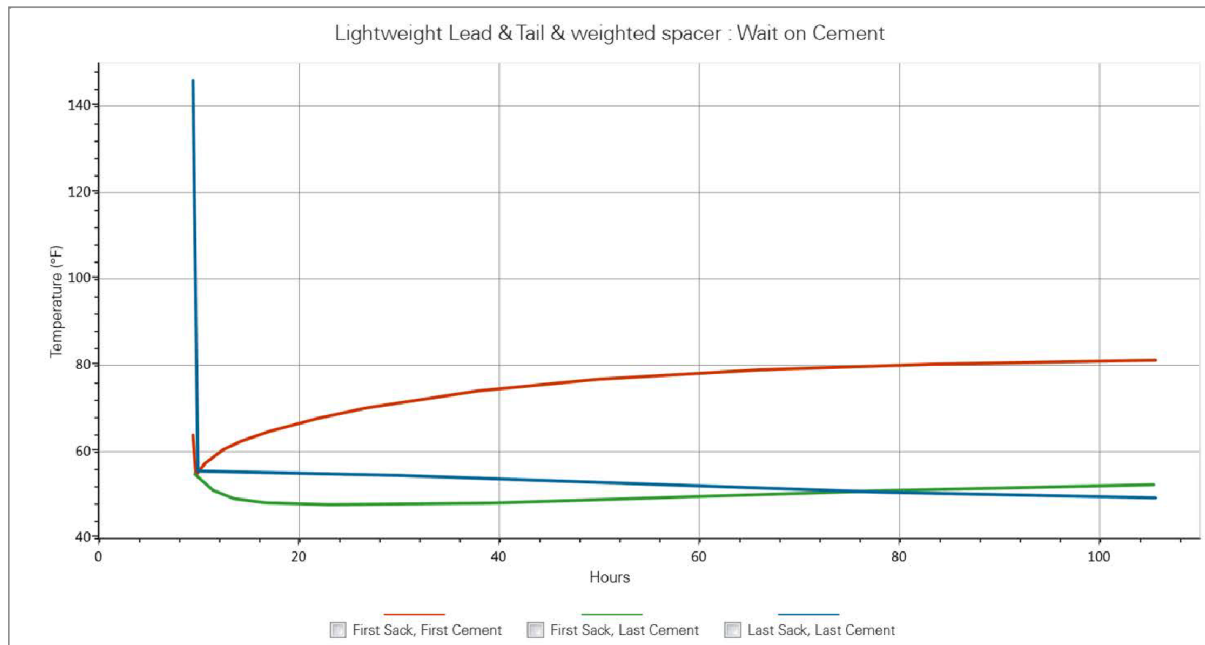

Horsepower, Pressure & Freefall

Time (mins)	Liquid Volume In (bbl)	Pump Output (hp)	Surface Pressure In (psi)	Surface Pressure Out (psi)	ECD @ Frac Zone (ppg)	Free Fall Height (ft)
0.00	0.0	0.00	0.00	1,892.15	9.75	921.29
12.08	60.4	1.80	0.00	1,892.15	9.76	1,135.34
28.45	142.2	1.80	0.00	1,892.15	9.76	1,344.28
61.45	307.2	1.80	0.00	1,892.15	9.77	1,052.90
94.44	472.2	1.80	0.00	1,892.15	9.78	1,036.47
127.44	637.2	1.80	0.00	1,892.15	9.78	1,037.68
160.44	802.2	1.80	0.00	1,892.15	9.77	1,038.89
193.44	967.2	1.80	0.00	1,892.15	9.77	1,040.09
226.43	1,132.2	1.80	0.00	1,892.15	9.77	1,041.30
259.43	1,297.1	1.80	0.00	1,892.15	9.77	1,042.50
292.43	1,462.1	1.80	0.00	1,892.15	9.77	1,043.71
325.42	1,627.1	1.80	0.00	1,892.15	9.76	1,044.91
358.42	1,792.1	1.80	0.00	1,892.15	9.76	1,046.11
391.42	1,957.1	1.80	0.00	1,892.15	9.76	1,047.32
424.42	2,122.1	1.80	0.00	1,892.15	9.76	1,048.52
449.36	2,246.8	1.80	0.00	1,892.15	9.76	1,055.68
481.85	2,409.2	1.80	0.00	1,892.15	9.76	2,516.50
514.33	2,571.6	1.80	0.00	1,892.15	9.83	2,496.81
535.35	2,691.1	2.88	0.00	1,892.13	9.90	1,954.36
553.68	2,837.7	7.15	21.80	1,892.15	9.95	0.00
562.85	2,911.1	115.01	572.33	1,892.15	9.96	0.00

Cementing the 20 inches surface casing

Tail Cement.20" Casing

Offshore

Description	Volume (bbl)	Bulk Cement (94 lb sacks)	Duration (min)
Angola-Lead Cement	24,48	64,52	4,90
Angola-Tail Cement	2528,36	10593,80	505,67

ECD & Hydrostatic Pressure Plot at Reservoir Zone

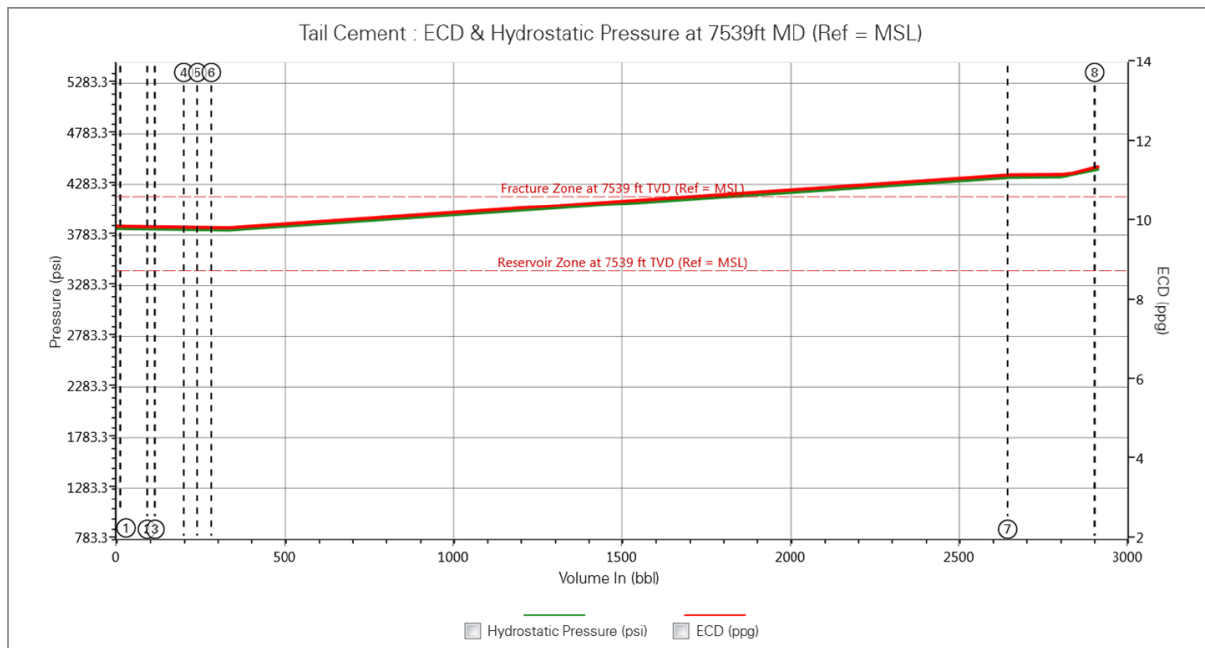

Cementing the 20 inches surface casing

ECD & Hydrostatic Pressure Plot at Fracture Zone

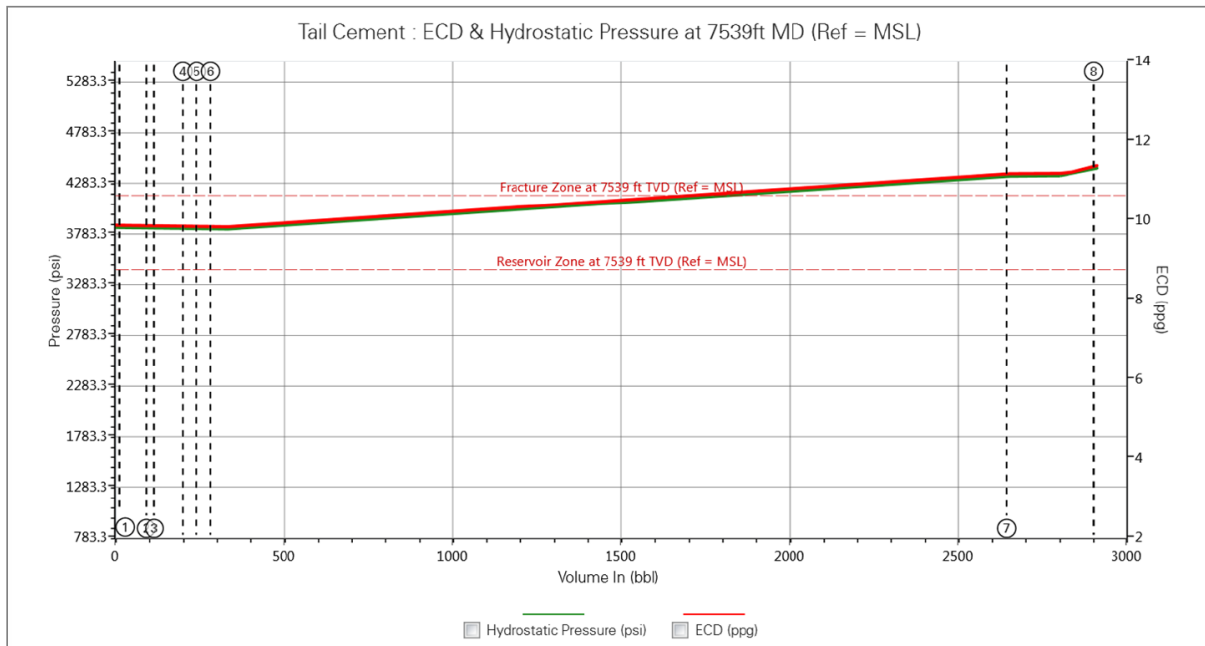

Flow Potential Plot

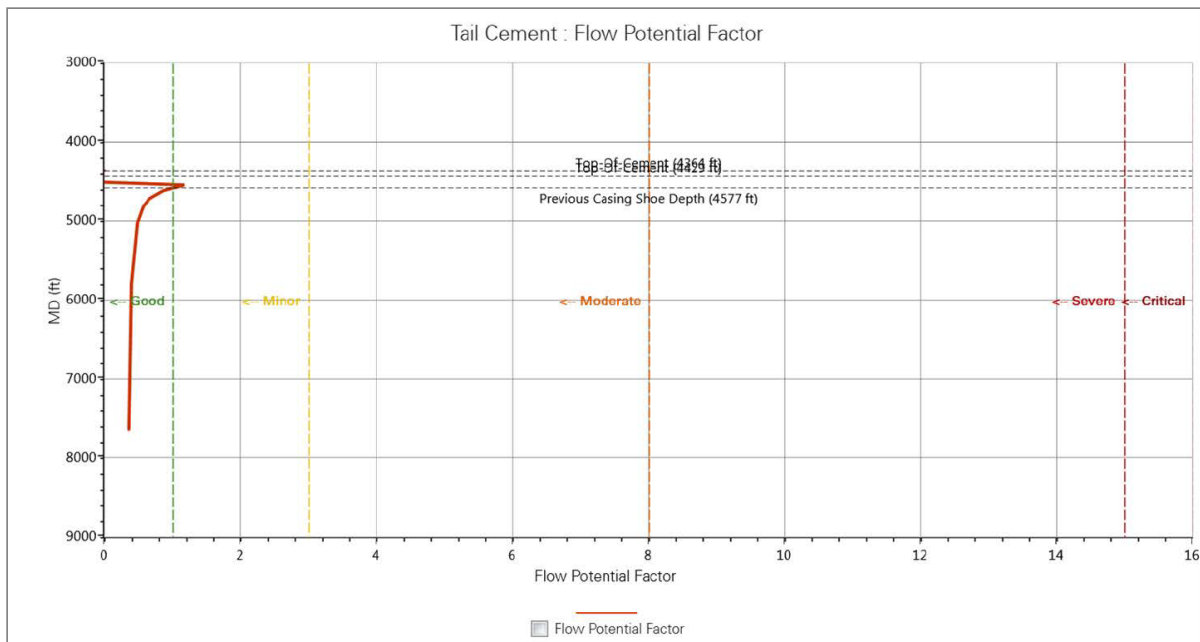

Cementing the 20 inches surface casing

Critical Static Gel Strength Plot

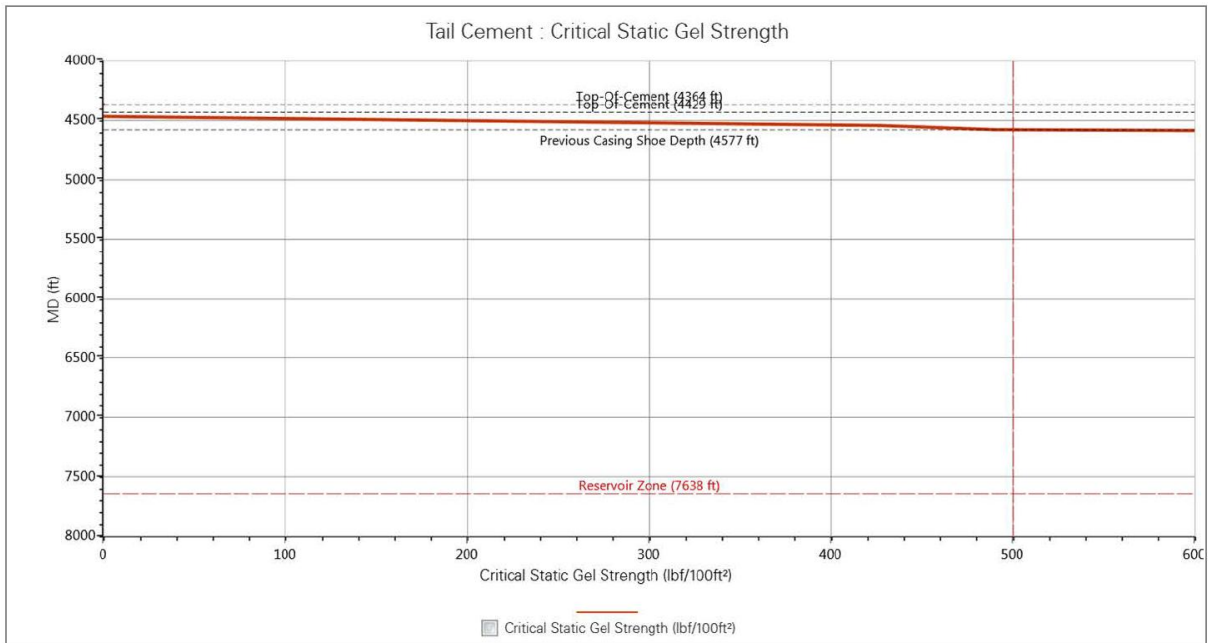

Slurry Placement Temperature Plot

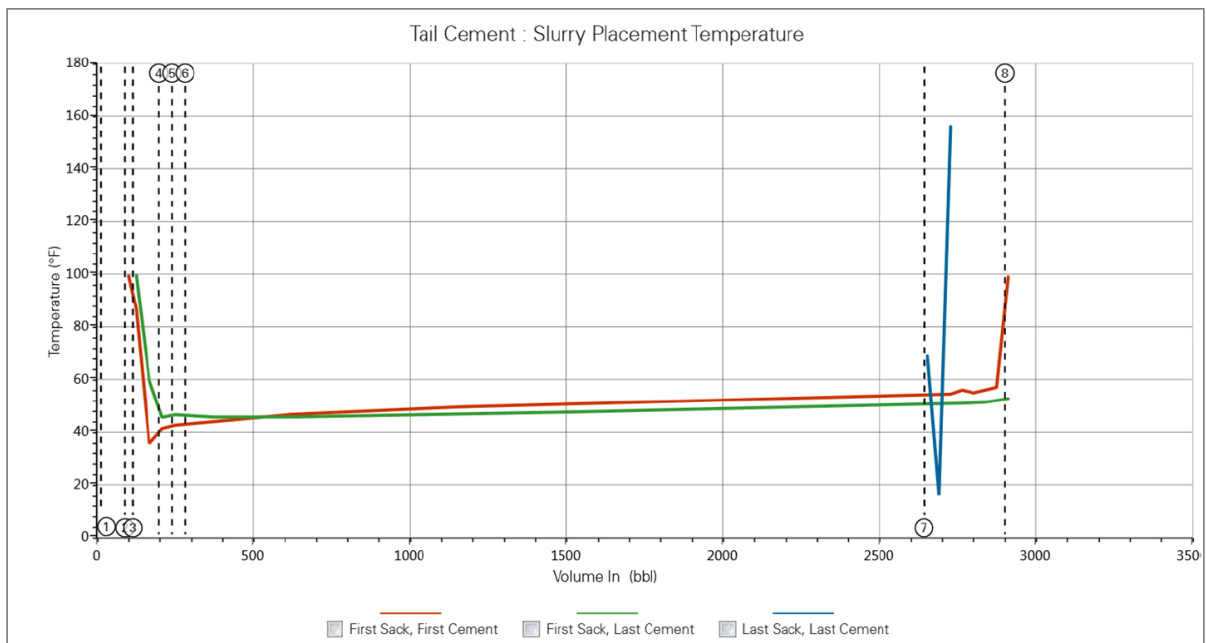

Cementing the 20 inches surface casing

Job Summary at Reservoir Zone

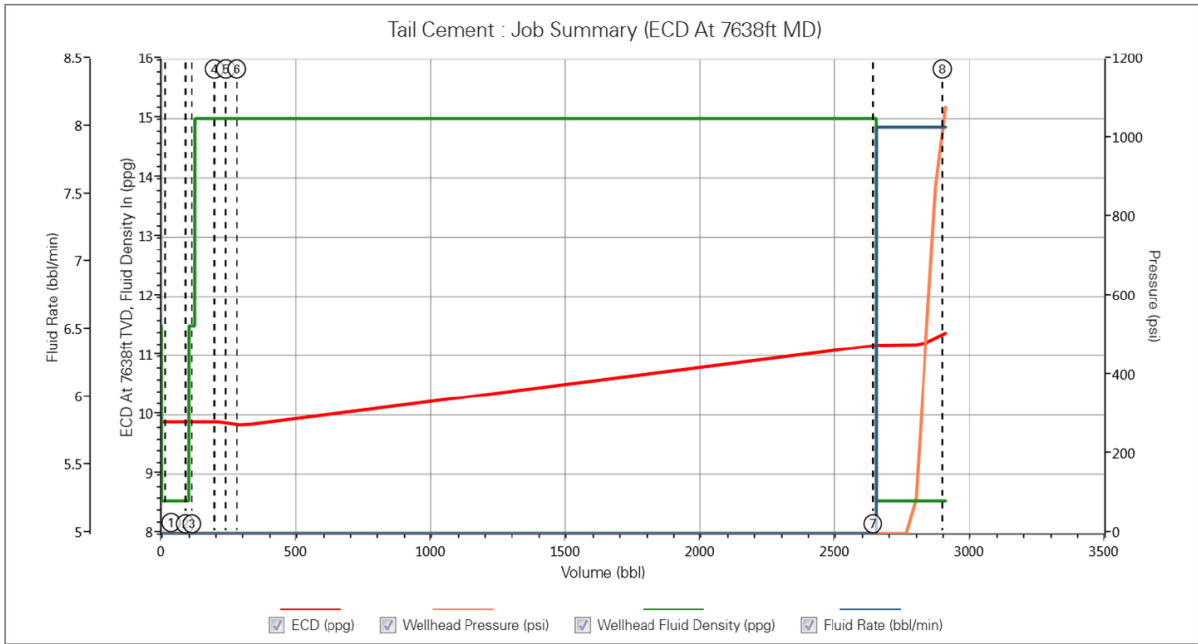

Comparison of Rate In and Out Plot

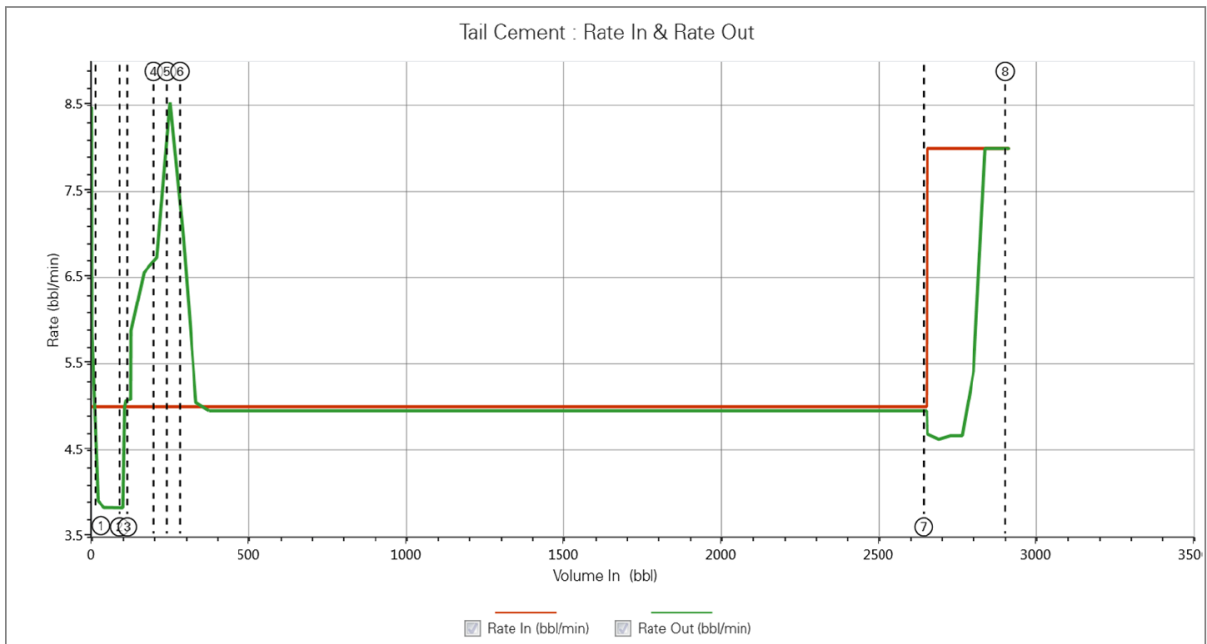

Cementing the 20 inches surface casing

Wait on Cement Plot

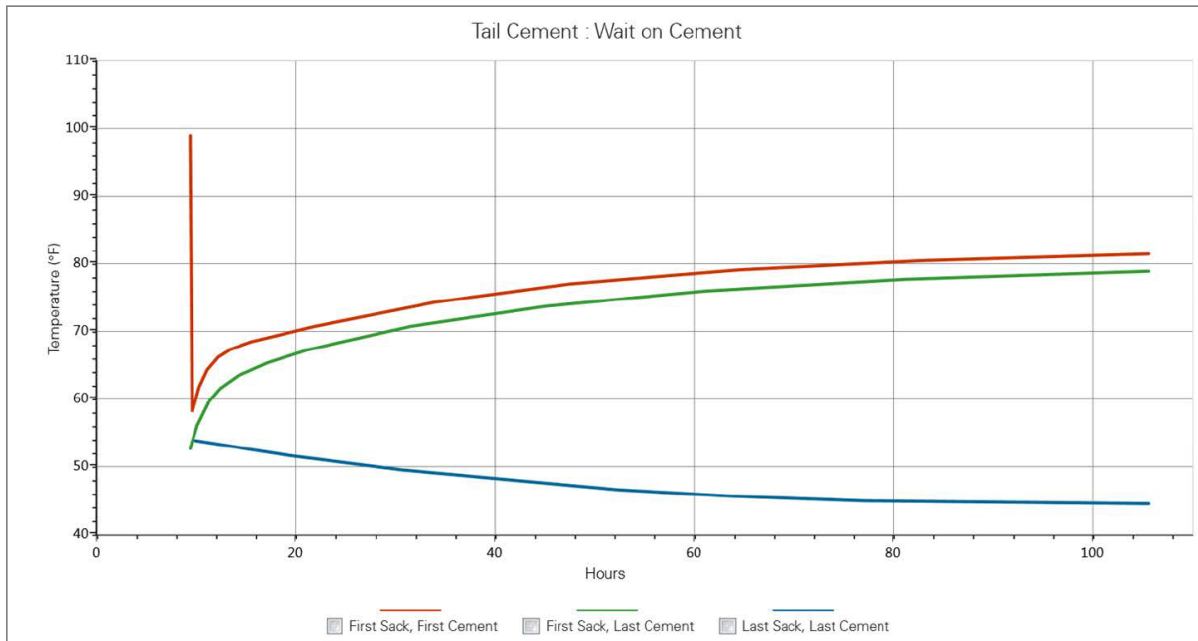

Final Annular Fluid Density

Measured Depth (ft)	Density (ppg)	Foam Quality (%)	Hydrostatic Gradient (psi/ft)
4,363.5	8.54	0.00	0.444
4,378.8	11.50	0.00	0.444
4,416.5	11.50	0.00	0.446
4,542.9	15.00	0.00	0.454
4,638.8	15.00	0.00	0.461
4,767.1	15.00	0.00	0.470
4,921.6	15.00	0.00	0.480
5,076.2	15.00	0.00	0.489
5,230.7	15.00	0.00	0.498
5,385.2	15.00	0.00	0.506
5,539.8	15.00	0.00	0.514
5,694.3	15.00	0.00	0.521
5,848.8	15.00	0.00	0.528
6,003.4	15.00	0.00	0.535
6,157.9	15.00	0.00	0.541
6,312.4	15.00	0.00	0.547
6,467.0	15.00	0.00	0.553
6,621.5	15.00	0.00	0.558
6,776.0	15.00	0.00	0.563
6,930.5	15.00	0.00	0.568
7,085.1	15.00	0.00	0.573
7,239.6	15.00	0.00	0.577
7,394.1	15.00	0.00	0.581
7,539.4	15.00	0.00	0.585
7,637.5	15.00	0.00	0.588

Cementing the 20 inches surface casing

Hook Load Plot

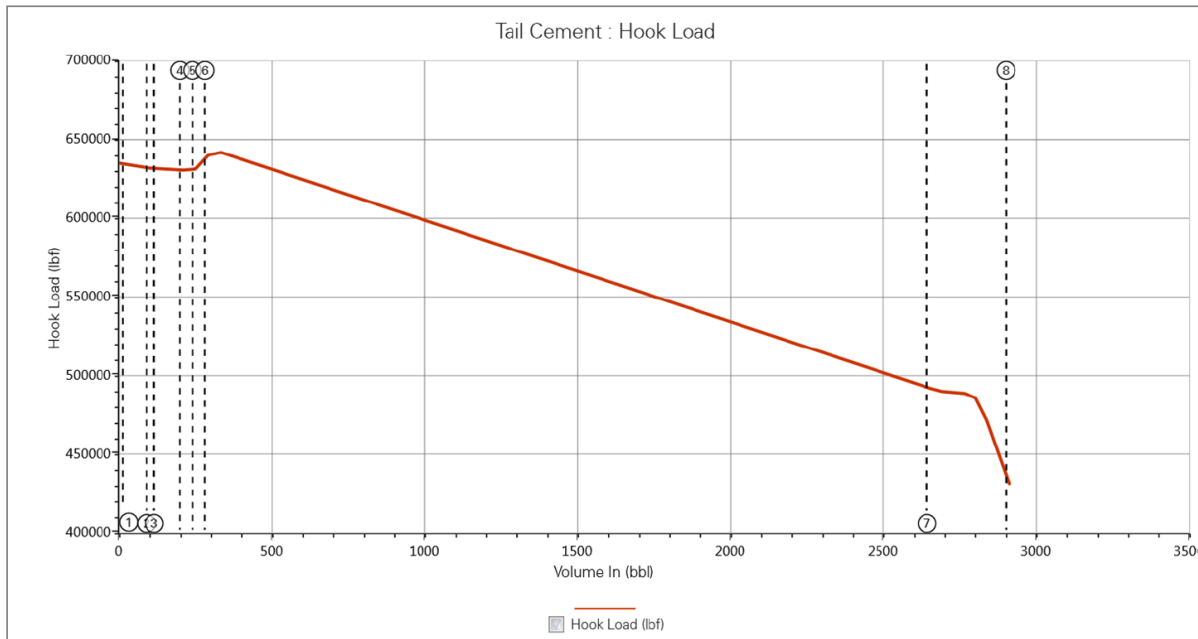

Horsepower, Pressure and Freefall

Time (mins)	Liquid Volume In (bbl)	Pump Output (hp)	Surface Pressure In (psi)	Surface Pressure Out (psi)	ECD @ Frac Zone (ppg)	Free Fall Height (ft)
0.00	0.0	0.00	0.00	1,892.15	9.75	921.29
12.08	60.4	1.80	0.00	1,892.24	9.76	492.59
21.14	105.7	1.80	0.00	1,892.25	9.76	193.40
24.90	124.5	1.80	0.00	1,892.16	9.76	203.47
49.95	249.8	1.80	0.00	1,892.00	9.73	2,016.15
83.10	415.5	1.80	0.00	1,892.15	9.76	2,533.24
116.25	581.2	1.80	0.00	1,892.15	9.86	2,484.08
149.39	747.0	1.80	0.00	1,892.15	9.95	2,434.92
182.54	912.7	1.80	0.00	1,892.15	10.04	2,385.77
215.68	1,078.4	1.80	0.00	1,892.15	10.14	2,336.61
248.83	1,244.1	1.80	0.00	1,892.15	10.23	2,287.45
281.97	1,409.9	1.80	0.00	1,892.15	10.33	2,238.29
315.12	1,575.6	1.80	0.00	1,892.16	10.42	2,189.13
348.27	1,741.3	1.80	0.00	1,892.16	10.51	2,139.98
381.41	1,907.1	1.80	0.00	1,892.16	10.61	2,090.82
414.56	2,072.8	1.80	0.00	1,892.16	10.70	2,041.66
447.70	2,238.5	1.80	0.00	1,892.16	10.80	1,992.50
480.85	2,404.2	1.80	0.00	1,892.16	10.89	1,943.35
513.99	2,570.0	1.80	0.00	1,892.16	10.98	1,894.19
535.35	2,691.1	2.88	0.00	1,892.15	11.04	1,354.53
553.68	2,837.7	96.26	476.61	1,892.15	11.07	0.00
562.85	2,911.1	214.17	1,078.43	1,892.15	11.23	0.00