



NTNU – Trondheim
Norwegian University of
Science and Technology

Experimental optimization of energy efficient drum dryer with a CO₂ heat pump system

Yashuo Li

Mechanical Engineering

Submission date: March 2013

Supervisor: Trygve Magne Eikevik, EPT

Co-supervisor: Håvard Rekstad, IPM
Peder Bengtsson, ASKO

Norwegian University of Science and Technology
Department of Energy and Process Engineering



Norwegian University of
Science and Technology

Experimental optimization of energy efficient drum dryer with a CO₂ heat pump system

Yashuo Li

Master of Energy and Environmental Engineering

Submission date: Mars 2013

Supervisor: Trygve Magne Eikevik, EPT

Co-supervisor: Inge Håvard Rekstad, EPT

Norwegian University of Science and Technology

Department of Energy and Process Engineering

MASTER THESIS

for

student Yashuo Li

Fall semester 2012

Experimental optimization of energy efficient drum dryer with a CO₂ heat pump system

Eksperimentell optimalisering av en energieffektiv tørketrommel med CO₂ varmepumpe system

Background and objective

Drum dryers have been used for a long time in homes for drying of laundries. These dryers have been developed over years from the simple type with direct electric heaters and rejection of the humid air to the ambient. The next generation included a heat exchanger between the inlet air and the exit air from the drum (condensation units). In this case it is possible to reduce the electric consumption. More modern system have been developed with a heat pump for cooling of the air to a temperature below the dew point (condensation and removal of water) and then reheating of the inlet air to the drum dryer. In this case we have a closed loop of the air in the dryer. Typical working fluid in this type of dryer is R134a. This refrigerant has a GWP factor of 1300. The industry of these type of dryers like to reduce the environmental impact factor of their systems and have looked into using CO₂ as the working fluids in the heat pump system. Our department has over a period worked together with an industrial partner to developed a new system working with CO₂.

In this project the first CO₂ heat pump prototype should be taken from the initial dryer and be reinstalled in a new design of the drum dryer. The first part of the project will be the installation of the new system and get it in operation. The next phase will be running of drying experiments. The last part will be eventually modification of the CO₂ process for minimization of the energy consumption and develop a strategy for controlling the process.

The following tasks are to be considered:

1. Literature review for use of CO₂ in drum dryers
2. Installation of the sub cooler in the CO₂ heat pump drum dryer
3. Experimental tests
4. Optimization of heat pump drying cycle and energy consumption
5. Making a draft scientific “paper” from the results from the projects
6. Proposal for further work

Within 14 days of receiving the written text on the master thesis, the candidate shall submit a research plan for his project to the department.

When the thesis is evaluated, emphasis is put on processing of the results, and that they are presented in tabular and/or graphic form in a clear manner, and that they are analyzed carefully.

The thesis should be formulated as a research report with summary both in English and Norwegian, conclusion, literature references, table of contents etc. During the preparation of the text, the candidate should make an effort to produce a well-structured and easily readable report. In order to ease the evaluation of the thesis, it is important that the cross-references are correct. In the making of the report, strong emphasis should be placed on both a thorough discussion of the results and an orderly presentation.

The candidate is requested to initiate and keep close contact with his/her academic supervisor(s) throughout the working period. The candidate must follow the rules and regulations of NTNU as well as passive directions given by the Department of Energy and Process Engineering.

Risk assessment of the candidate's work shall be carried out according to the department's procedures. The risk assessment must be documented and included as part of the final report. Events related to the candidate's work adversely affecting the health, safety or security, must be documented and included as part of the final report. If the documentation on risk

assessment represents a large number of pages, the full version is to be submitted electronically to the supervisor and an excerpt is included in the report.

Pursuant to “Regulations concerning the supplementary provisions to the technology study program/Master of Science” at NTNU §20, the Department reserves the permission to utilize all the results and data for teaching and research purposes as well as in future publications.

The final report is to be submitted digitally in DAIM. An executive summary of the thesis including title, student’s name, supervisor's name, year, department name, and NTNU's logo and name, shall be submitted to the department as a separate pdf file. Based on an agreement with the supervisor, the final report and other material and documents may be given to the supervisor in digital format.

- Work to be done in lab (Water power lab, Fluids engineering lab, Thermal engineering lab)
 Field work

Department of Energy and Process Engineering, September 13th 2012

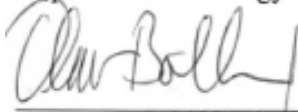

Prof. Olav Bolland
Department Head

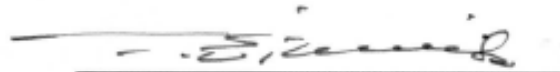

Prof. Trygve M. Eikevik
Academic Supervisor
e-mail: trygve.m.eikevik@ntnu.no

Research Advisors:

Håvard Rekstad, NTNU, havard.rekstad@ntnu.no

Peder Bengtsson, ASKO, peder.bengtsson@asko.se

Acknowledgements

I would like to thank my supervisor, Trygve.M.Eikevik from NTNU, my co-supervisor: Håvard Rekstad from NTNU, and employee Peder Bengtsson from ASKO for their assistance for my project work.

Trondheim, Mars 2013

Yashuo Li

Summary

Since early twentieth century, drum dryer was used to dry clothes, and soon became a glowing industry.

A drum dryer is a household appliance that is used to remove moisture from a load of clothing and other textiles, generally. At the beginning a simple electrical drum dryer was used, then different development has been made for meeting different needs and changing industrial environment, such as spin dryer, condenser dryer, heat pump dryer etc.

The working mechanism of a drum dryer is that clothes is dried by heated air in a rotating drum: the heated air absorbs water evaporated from the wet clothes, so that the clothes is dried. The rotating drum is due to maintaining air space both between the load and between the loads and the drum surface. The way of how the air is heated and how the water is condensed is of interest.

A heat pump dryer has the potential for energy saving and is good for environment. ASKO has developed to types of heat pump using different refrigerant: R134a and R744. This project will focus on the application of a CO₂ (R744) heat pump. A prototype has already been built, an assumption was made from former project that more cooling after compression for the refrigerant will be beneficial for increasing the energy efficiency of the whole system. So new external gas coolers will be installed and some optimization and analysis will be made for this project.

Sammendrag

Siden begynnelsen av det tjuende tallet, ble tørketrommel brukes til å tørke klær, og snart ble en gløende industri.

En tørketrommel er en husholdningsmaskiner som brukes til å fjerne fuktighet fra en last av klær og andre tekstiler, generelt ved begynnelsen ble enkel elektrisk trommel tørketrommel brukt, etterpå annen utvikling er gjort for å møte ulike behov og skiftende industrielt miljø, slik som spin tørketrommel, kondensertørketrommel, varmepumpe tørketrommel osv.

Den arbeid mekanisme av en tørketrommel er at klærne er tørket ved oppvarmet luft i en roterende trommel: den oppvarmede luften absorberer vann fordampet fra våte klær, slik at klærne er tørket. Den roterende trommel kan opprettholde luftstrømmet både mellom klærne og mellom klærne og trommelflaten. Måte for å varme opp luften og kondensere vannet er av interesse.

En varmepumpe tørketrommel har potensial for energisparing og er bra for miljøet. ASKO har utviklet to typer varmepumpe ved bruk av to ulike kuldemedium: R134a og R744. Dette prosjektet vil fokusere på anvendelse av CO₂ (R744) varmepumpe. En prototyp er allerede bygget, en antagelse ble gjort fra tidligere prosjekt som er at mer kjøling for kuldemediets etter kompressjon vil være fordelaktig for å øke energieffektiviteten av hele systemet. Så nye eksterne gass kjølere vil bli installert og noen optimalisering og analyse vil bli gjort for dette prosjektet.

Table of contents

Acknowledgements	5
Summary	6
Sammendrag	7
Nomenclature	10
1. Literature review	11
1. Literature review	11
2 Preparation and theory	12
2.1 working principle of the experimental drum dryer	12
2.2 CO ₂ as refrigerant	14
2.2.1 The properties of CO ₂	14
2.3 Process analysis	17
2.4 refrigerant charge	21
3 practical information for experiments	27
3.1 components	27
3.1.1 Compressor	27
3.1.2 Evaporator	33
3.1.3 Gas cooler	37
3.1.4 External gas coolers	40
3.2 safety and operating guidelines	43
3.2.1 Effects on human	43
3.2.2 Metal compatibility	44
3.2. Operating pressures and temperatures	46
3.3 Pressure at standstill	46
4 Results and discussion	47
4.1 Instrument overview	47
4.2 Experiments overview	49
4.3 Experiment result and analysis	50
4.3.1 Experiment nr.1	50
4.3.2 Experiment nr.2	58
4.3.3 Experiment nr.3	65
4.3.4 Experiment nr.4	69
4.3.5 Experiment nr.5	78
4.3.6 Experiment nr.6	85
4.3.7 Experiment nr.7	92
4.3.8 Experiment nr.8	99

4.3.9 Experiment nr.9	105
4.3.10 Experiment nr.10	112
4.4 Comparison and discussion	119
5 Conclusion.....	121
6 Further work.....	124
Reference.....	125
Appendices	126
Appendix A: p-h diagram for Carbon Dioxide Refrigerant	126
Appendix B: System failure	126
Appendix C: Calculation of the refrigerant charge	128
Appendix D: Original data from each experiment	128
Appendix E: Modified and calculated data from each experiment	128

Nomenclature

CO₂ = Carbon dioxide

R134a = Tetrafluoroethane (CH₂FCF₃)

COP = Coefficient of performance

SMER = Specific moisture extraction rate

h = Enthalpy

GWP = Global warming potential

x = Absolute humidity

L = Length

M = Mass flux

Bar = Absolute bar pressure

v = Specific volume

RH = ϕ = Relative humidity

P=pressure

P = Electric power

1. Literature review

1. Literature review

Drum dryer mentioned in this master thesis is used for clothes drying. The drum dryer, also known as tumble dryer drum is a household appliance. The basic mechanism of this type machine is that heated air is going through a drum with wet clothes in, absorbs water evaporated from the wet clothes, so that the clothes is dried. The rotating drum is due to maintaining air space both between the load and between the loads and the drum surface. A total energy consumption for household appliance estimated in United States is around 3%. [1] so several optimization methods are proposed in order to increase the energy efficiency.

The first generation of the drum dryer for clothes is by drawing cool air from the ambient, heating it and then flowing through the rotating drum dryer to dry the clothes. The resulting heated, humid air is the dumped to the ambient. More dry and cold air is drawn into the machine to continue the process. This design is simple and functional, but doesn't take consideration of any kind of heat recovery and environmental aspect.

Then Winstel [2] suggested a method for utilization of the heated exhaust gas from the dryer. The fresh air is first drawn into a heat exchanger, and exchange heat with the heated exhaust air with high humidity and then heated to the proper temperature before going into the dryer. The idea of a condenser dryer is coming out to simplify the installation of the dryer and increase. This type of the dryer contains two loops. The inside loop is circulated with air, the air is first heated and then goes though the rotating drum to absorb moisture, afterwards the moist air is cooled down to its saturation temperature in a heat exchanger with ambient air or water. The water vapor in the air condenses and is stored either in a water tank or drained to a duct line. The cooled and dried air is heated again to complete the circle. Since the drum dryer is always located in an apartment, an extra duct line though out the building for exhaust air is needed. The advantage of the condenser dryer is that the extra duct line for exhaust air is not needed compared to the conventional drum dryer. Another loop is used for exchanging heat between moist air from the inside loop and the ambient air or water to condense the moisture from the hot air. Bansal et al[3] developed a condenser dryer model described above and

found out that the energy efficiency is about 7% higher than the conventional air-vented drum dryer.

Condenser dryer is relatively suited for cold or moderate climate. In a high temperate climate the condensing rate of water vapor is lowed and thus more time or energy is needed for drying clothes. This type of the condensers is still in the marked and produced by for example: Asko, AEG, Miele , Malber, Bosch and Eurotech. But both the conventianl(air vented) drum dryer and condenser dryer still don't meet the European energy efficiency standards.

With most current standalone condenser dryers, it is necessary to periodically clean the condenser unit - perhaps once a month or so, one needs to slide out the condenser module and wash off any accumulated lint. Thus condensers require a bit more "work" than vented dryers - although this may entail less actual effort than the recommended annual ductwork cleaning for vented dryers, which is very important for both performance and fire safety reasons.

A more efficient method is to use the heat pump: A tumble dryer with a heat pump system Takushima et al. [5] developed and tested two prototype air cycle heat pump dryers. They presented steadystate results in terms of the rate at which moisture could be removed for fixed inlet humidity and found significantly improved performance as compared with a conventional dryer. They varied the rate of heat transfer from an ambient heat exchanger and found moisture removal rates of up to about 6 times the rates associated with a conventional dryer.

2 Preparation and theory

2.1 working principle of the experimental drum dryer

The drum dryer developed in the lab is a closed-loop dryer with the help of a heat pump condensing moisture and warming up air.

The system contains two main loops: an air loop and a CO₂ loop.

When machine starts, sealing the air is sealed. It is first heated by gas cooler and distributed throughout the wet clothing while the drum is rotating. After the dry, heated air is absorbed with water vapor, the moisture air flow through an evaporator, and condenses in a water container. The water container can be taken out to measure how much water is condensed. Then the dried air with reduced temperature flows to a gas cooler, and is heated again, and flows back to rotating drum. That is the air loop of the system. Figure below shows how the air loop works.

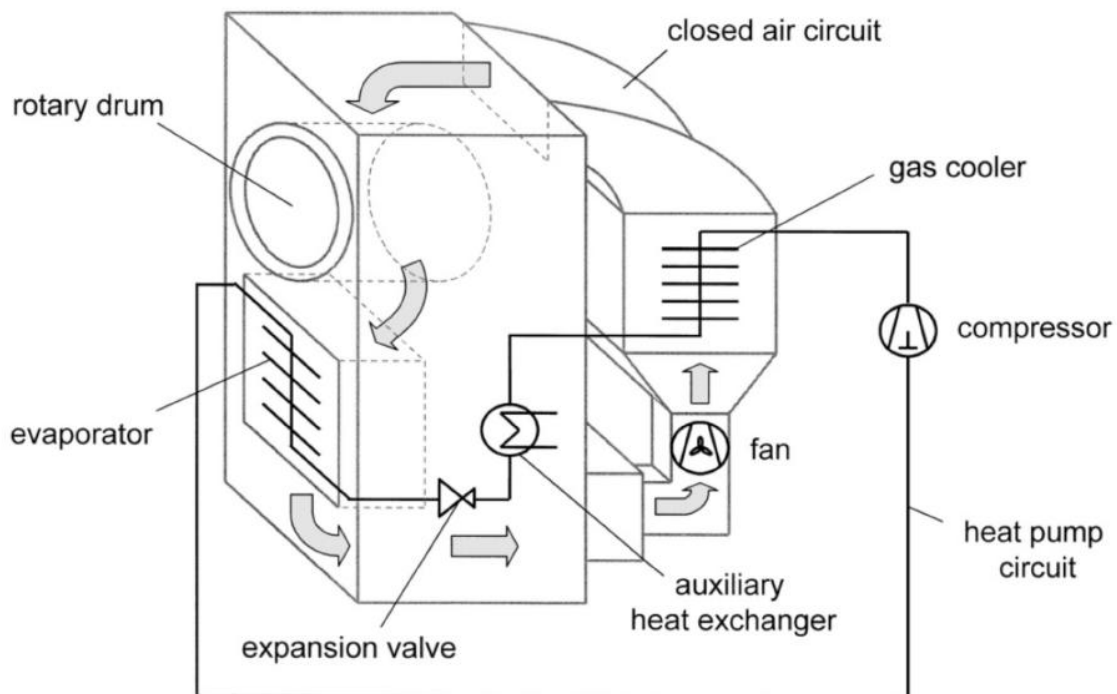

Figure 1 Carbon dioxide heat pump dryer(Kløcker, et al.,2001)

Another loop is a fully closed loop using heat pump to heat and condense refrigerant. A heat pump can transfer energy from a heat source to a heat sink, unlike electric heater, which transfers electricity directly to energy, and is used in conventional drum dryer, The heat pump can generate more heat using same amount electricity compared to what conventional electric heater does. In this project the refrigerant is chosen to be CO₂. So the heat pump drum dryer is a more environment-friendly and efficient choice compared to a conventional drum dryer.

The CO₂ loop: The saturated CO₂ vapor from evaporator is drawn into a compressor and compressed to a certain pressure in high temperature, the supercritical CO₂ is then cooled in a gas cooler which exchanges heat with dried air, so the dried air is heated and the CO₂ vapor is cooled. The CO₂ vapor is further cooled down in an external gas cooler, in this external gas cooler, the CO₂ vapor exchanges heat with ambient air flow induced by a fan. Since the CO₂ vapor is still in supercritical region, the rejecting heat results in a temperature glide, unlike the traditional condenser, in which the temperature is kept constant. After the external gas cooler, CO₂ vapor is expanded either in a capillary tube or an expansion valve. With reduced temperature and pressure, the CO₂ vapor flows into the evaporator and exchanges heat with the moisture air, then flows to the compressor to start next circuit.

2.2 CO₂ as refrigerant

Experiments for using CO₂ as refrigerant can go back to 1850, but it was facing low critical temperature problem, and when the halocarbon refrigerants was more and more used, the CO₂ was phased out. However, the people found out that the halocarbon refrigerants can be harmful to the environment, and then [5] Lorentzen and Pettersen came with a solution by operating CO₂ in transcritical region. In this method a gas cooler is employed instead of condenser, which was commonly used for halocarbon refrigerant applications.

The advantages for operating the system in transcritical region in this project is that the heat rejection takes place over a large temperature glide, which can heat the air more efficient and faster; offers a simpler capacity control; the CO₂ is cheaper and more environmental friendly.

2.2.1 The properties of CO₂

CO₂, also referred to as “R744”, is commonly used in nowadays industry and various applications. For example: food freezing, fire extinguishing, refrigerant, maintenance of ideal atmospheric conditions during transportation, etc.[12]

CO₂ is present in the atmosphere at concentration levels of about 380 ppm. It is gas form in normal conditions, and is odorless at low concentrations and slightly toxic with a slightly

pungent, acid taste. The concentration of carbon dioxide (CO₂) in earth's atmosphere has reached 391 ppm (parts per million) as of October 2012⁽⁸⁾

Some of the physical properties is listed in the table below and will be useful for the project

Molecular formula	CO ₂
Molar mass	44.01 g mol ⁻¹
Appearance	Colorless gas
Odor	Odorless
Density	1562 kg/m ³ (solid at 1 atm and -78.5 °C)
	770 kg/m ³ (liquid at 56 atm and 20 °C)
	1.977 kg/m ³ (gas at 1 atm and 0 °C)
Melting point	-78 °C, 194.7 K, -109 °F
Boiling point	-57 °C, 216.6 K, -70 °F (at 5.185 bar)
Solubility in water	1.45 g/L at 25 °C, 100 kPa
Acidity (pKa)	6.35, 10.33
Refractive index(nD)	1.1120
Viscosity	0.07 cP at -78.5 °C
Dipole moment	zero
Thermochemistry	
Std enthalpy of formation ΔfHo298	-393.5 kJ·mol ⁻¹
Standard molar entropy So298	214 J·mol ⁻¹ ·K ⁻¹

Table 2.1 physical properties is of CO₂

Figure below shows the pressure-temperature phase diagram of CO₂. From the figure we can see that CO₂ at -78.4 °C will form the so-called “dry ice”, since for this project the lowest temperature for CO₂ will be around 20 °C (room temperature), so the dangerous for the CO₂ becoming dry ice will be minimum. The critical temperature for R744 is 31 °C, which is very low, and the critical pressure is 73.6 bars, which is high. The triple point is at -56,6 °C and 5.2 bars. Those thermal conditions have important consequences for heat pump applications.

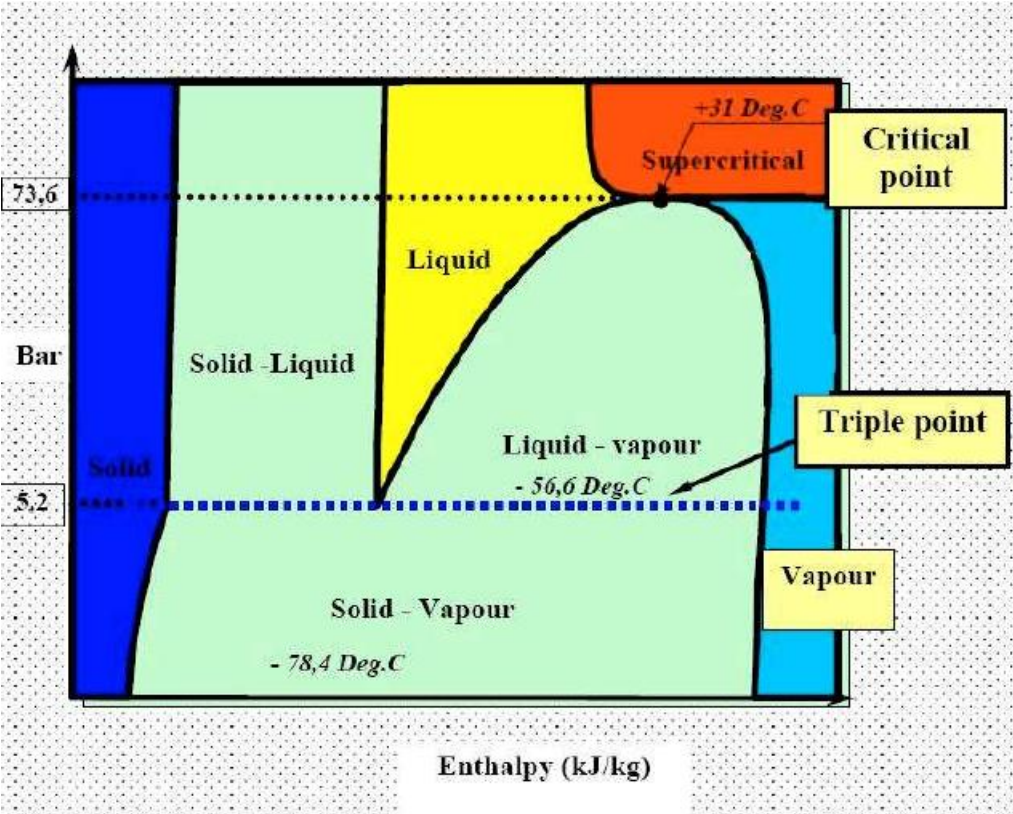

Figure 2. 1 Pressure-temperature phase diagram of R744(Danfoss)

Figure below shows the comparison of different evaporation pressures for refrigerant R744, R404A and R410A. This shows the R744 system will have to operate in much higher pressure.

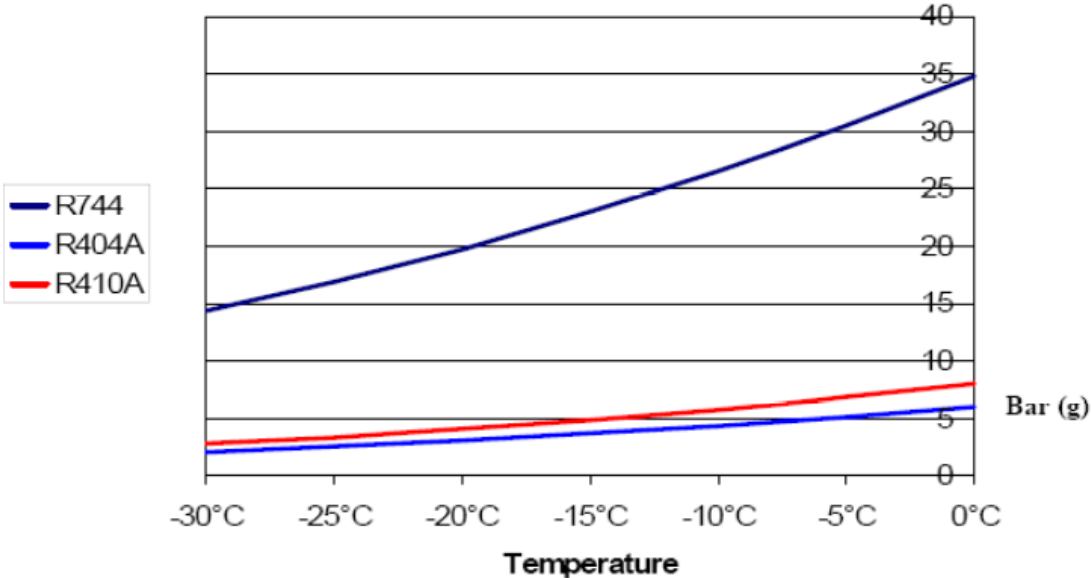

Figure 2. 2 Comparison of evaporating pressures

2.3 Process analysis

Relevant equations for further process analysis after experiments are listed below.

Figure below shows the p-h diagram of a R744 transcritical cycle, the index will be used for following equations.

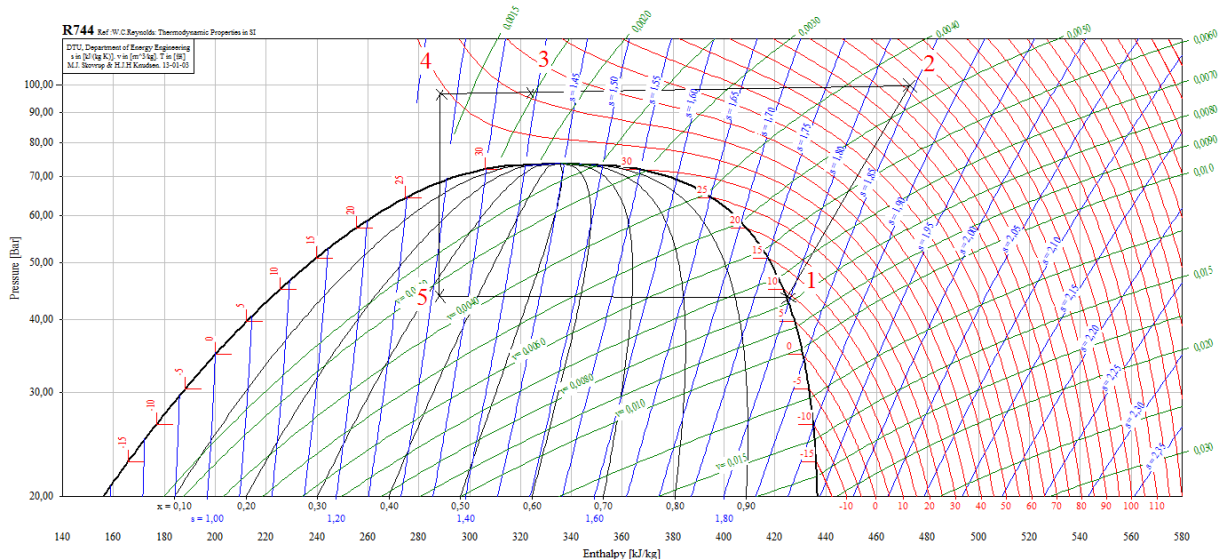

Figure 2.3 p-h diagram of a R744 transcritical cycle

Equations:

The refrigeration capacity is:

$$Q_0 = G_r(h_1 - h_5) \quad 2.1$$

Where Q_0 is the refrigeration capacity, G_r is the mass flow of the refrigerant, h_1 is the enthalpy of the refrigerant at evaporator outlet, h_5 is the enthalpy of the refrigerant at evaporator inlet.

Heating capacity of the air loop:

$$Q_c = G_r(h_2 - h_3) \quad 2.2$$

Where Q_c is the heating capacity of the air loop, which means, the heating capacity used for heating the air flow induced by a fan is not included, h_2 is the enthalpy of the refrigerant at compressor outlet, h_3 is the enthalpy of the refrigerant at gas cooler outlet.

Total heating capacity:

$$Q_{tc} = Q_c + Q_{ac} = G_r(h_2 - h_4) \quad 2.3$$

Where Q_{tc} is the total heating capacity including heating in the air loop and air flow induced by a fan, Q_{ac} is the heating capacity of the air flow induced by a, h_4 is the enthalpy of the refrigerant at external gas cooler outlet.

Heating capacity for the external gas cooler:

$$Q_{ac} = G_r(h_3 - h_4) \quad 2,4$$

Compressor work:

$$W_{comp} = G_r(h_2 - h_1) \quad 2,5$$

Where W_{comp} is the compressor work

Refrigeration factor and heating factor:

$$\varepsilon = Q_o / W_{tot} \quad 2,6$$

$$\varphi = Q_c / W_{tot} \quad 2,7$$

Where ε is the refrigeration factor, φ is the heating factor, both of them describes the COP (Coefficient of Performance) of the system, for the heating factor, since the energy used for heating the air flow induced by a fan cannot be utilized by system, Q_c is used for calculating heating factor instead of Q_{tc} , and W_{tot} is the total supplied work used to run the heat pump system(the energy used to run the drum is not included).

Total supplied work:

$$W_{tot} = W_{comp} + W_{fan} \quad 2,8$$

Where W_{fan} is the work used to run the fan.

The specific moisture extraction rate, SMER:

$$SMER = COP * dx/dh = dx/W_{tot}$$

2,9

Where SMER is the specific moisture extraction rate, it is a ratio of the mass of water extracted (condensed) on the evaporator to the total energy used for running the heat pump system, dx is the mass of extracted water.

The SMER number indicates the amount of the water extracted in the drying process and how much energy is consumed in a certain period. This number can be used to compare performance in similar drying systems.

Figure below shows h-x diagram for the air. Symbol A,B,C represents three stages of the air flow. In this project the air is cooled in the rotating drum and water is absorbed in the heated air, which represents symbol C, from the figure below it can be noticed that x (absolute water mass) is increased while the enthalpy is decreased since the temperature is lowered. Then the water in the air is condensed flowing through an evaporator, which represents symbol C, from the figure it can be seen that the enthalpy is keeping dropping and so does the water content. The air is then heated without any change of x value, which represents symbol B.

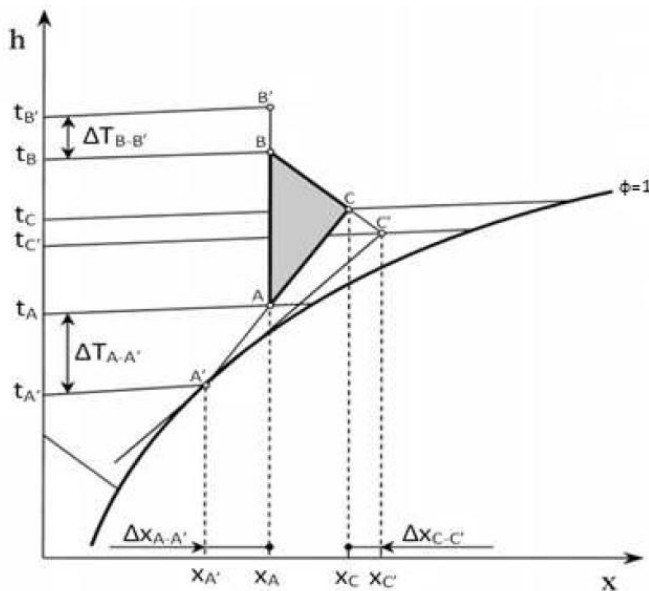

Figure 2. 4 h-x chart of the drying process[11]

2.4 refrigerant charge

For the recent years, the European regulation has been giving more and more concern about refrigeration systems. Refrigeration systems cannot guarantee a no-leakage condition, and thus the refrigerant leakage can lead to environment impact, danger to health, low system efficiency and system failure etc. [13]

A proper refrigerant charge is important for the system. Different amount of refrigerant charge can give different COP, heating and cooling capacity.

For example, if the refrigerant charge is too low, less surface area in the evaporator will be covered by liquid form of refrigerant, thus lowered cooling capacity and increased temperature difference, which will consume more energy from compressor if the same cooling load must be met. In this project, a hermetic compressor is used, a low refrigerant can also overheat the motor, which can reduce its life.

If the refrigerant charge is too high, less surface area will be covered by gas form of the refrigerant in the evaporator, which can result in too much liquid vapor pushed into compressor, damaging the compressor. The excess of the refrigerant can also back up in the condenser, reduce effective surface area and increase the average temperature level, which can cost the compressor more energy. Too much refrigerant charge will of also course increase the investment cost.

Figure [9] below for a transcritical R744 system shows that for different refrigerant charge, the process circles change. For increased refrigerant charge, the pressure in gas cooler and evaporator will increase, it can be also noticed that the enthalpy at the evaporator inlet is decreased dramatically with the increasing refrigerant charge, which will result in a changing cooling capacity. Since the pressure will increase at the evaporator, thus the temperature, so it may give a lower heat exchange rate, so whether the cooling capacity will increase or decrease is depending on the real situation. With the increasing refrigerant charge and decreasing temperature at gas cooler inlet, the heating capacity will also vary, depending on the real situation. The normalized charge in the figure is calculated as below:

$$\text{Normalized charge} = (m_{\text{actual}} - m_{\text{vapor}}) / (m_{\text{liquid}} - m_{\text{vapor}}) \quad 2.10$$

Where m_{actual} is the real mass flow of the refrigerant, m_{vapor} and m_{liquid} is the mass of the saturated vapor and liquid at temperature 25 °C, determined by multiplying the total volume of the system with the densities of saturated vapor and liquid at 25 °C, respectively.

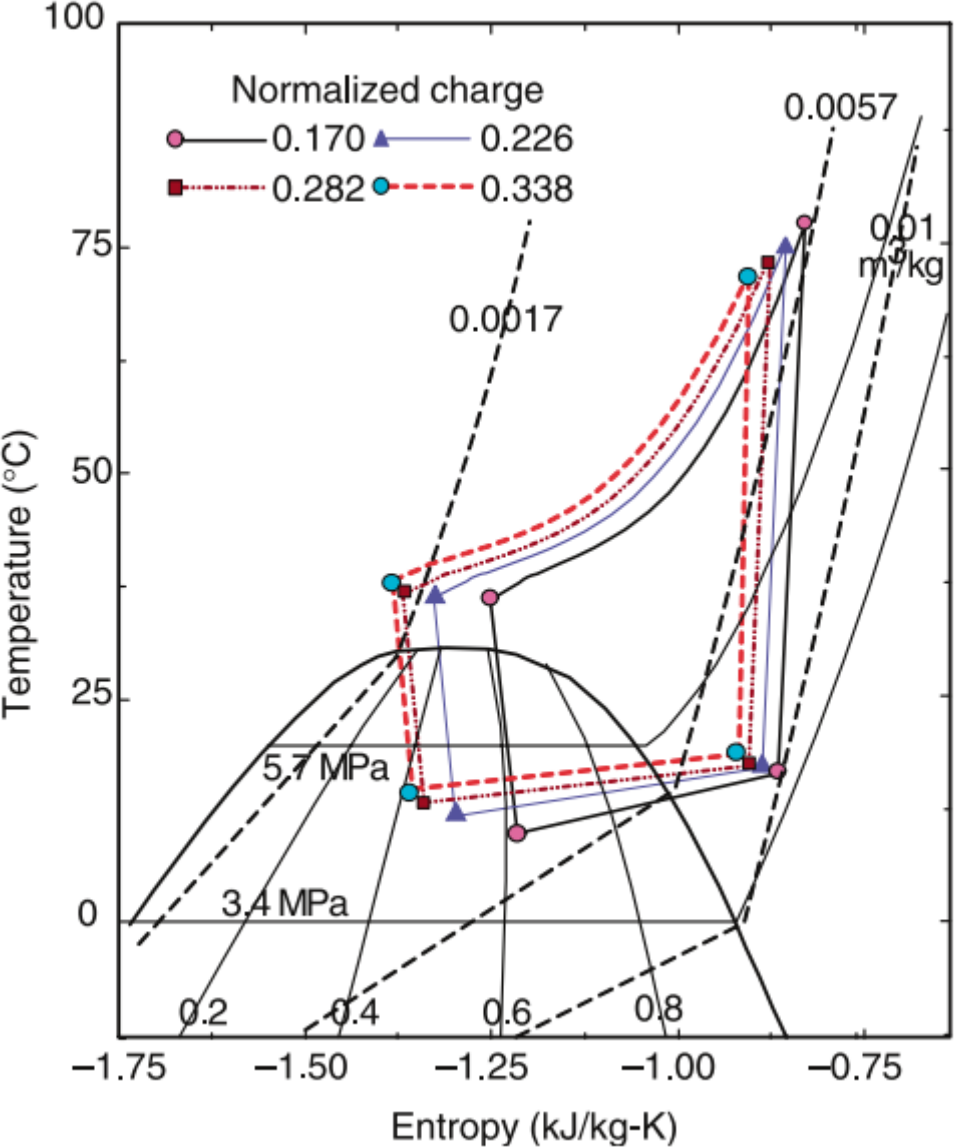

Figure 2. 5 Cycle variation with normalized charge[9]

For the same system, with increasing refrigerant charge, the quality(heat exchanging efficiency) of the gas cooler and evaporator is reduced rapidly, which means the increasing refrigerant charge can also give a reduction in the system efficiency after a certain value of the refrigerant charge.

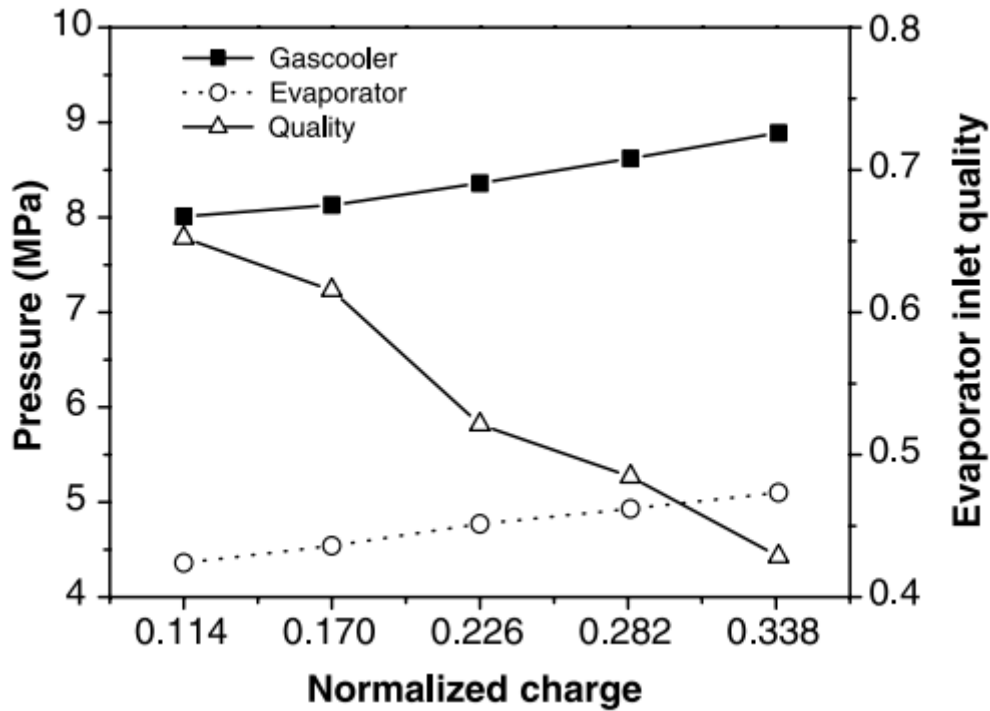

Figure 2. 6 Variations of pressures in gas cooler and evaporator and quality at the evaporator inlet with normalized charge[9]

For the same system described about, a resulting diagram is plotted below: COP, cooling capacity and compressor work versus refrigerant charge. In this system, the cooling capacity is increasing with increased refrigerant charge to a certain point, before that point, the speed of increasing cooling capacity is slowing down, and will stop, decrease while the refrigerant charge is still increasing. It can be noticed that the COP is increasing before 0,282(normalized charge value), and then begin to drop after that point. And the compressor work is increased all the way up, but relative slowly.

This indicates that there is one optimal value for COP, both overcharged and undercharged system will reduce the overall efficiency.

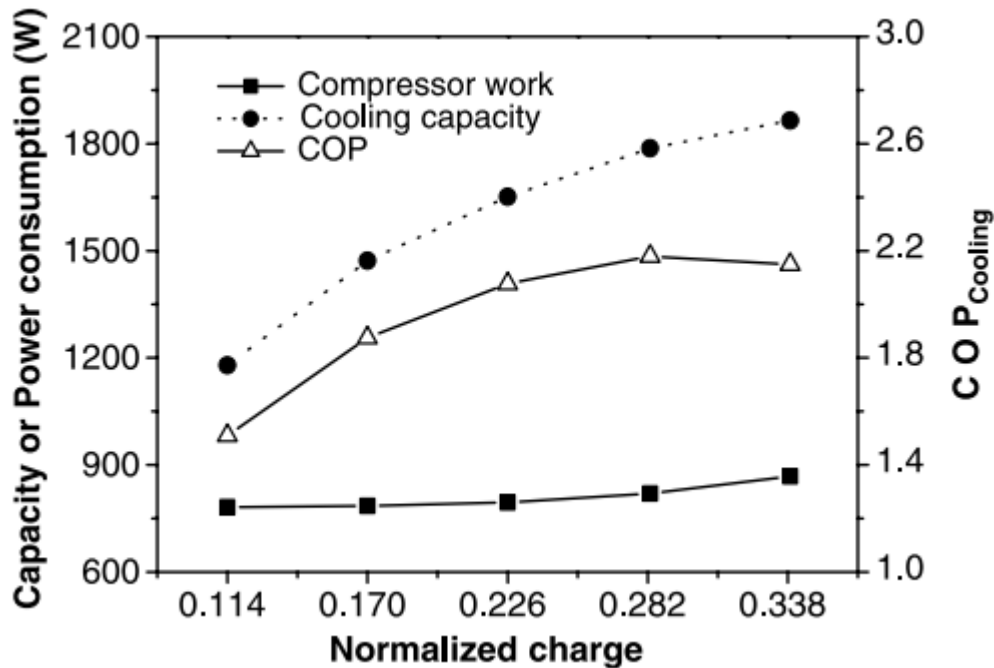

Figure 2. 7 Variations of compressor work, cooling capacity, and COP with normalized charge[9]

The total refrigerant charge depends on the components of the system and refrigerant properties. In this project, a compressor, a gas cooler, an evaporator, a capillary tube, an external gas cooler with variable volume and tubes connecting each components are employed. two cases should be distinguished:

- Gas form: the gas form contains in gas cooler, external gas cooler, compressor and tubes connecting components mentioned above.
- Two-phase form: liquid and gas form contains in evaporator, capillary tube and tubes connecting capillary tube and evaporator.

The critical components are capillary tube and evaporator, because the liquid form in those components is with high mass and low volume, and it is hard to determine the liquid-gas distribution in practical during operation in those components.

Refrigerant charge estimation

The basic equation used for estimating refrigerant charge is as below:

$$m_{tot} = \sum m_i = m_{evp} + m_{cond} + m_{exp} + m_{tub} \quad 2.11$$

where m_{tot} , m_{evp} , m_{cond} , m_{exp} , m_{tub} are the total amount of mass in the system, the amount of mass in the evaporator, the amount of mass in the condenser, the amount of mass in the expansion valve, the amount of mass in the tubes connecting each components, respectively.

The idea of the equation above is to estimate the ideal operating condition of the system first, and then with the estimated pressure and temperature at each component, it is possible to calculate the amount of mass flow at each component. The summation of the amount of mass at each component is the total refrigerant charge.

To calculate the amount of mass at each component, the following equations can be applied:

$$m_i = \int_0^L \rho dV = A_i \int_0^L \rho dl \quad 2.12$$

Where m_i is the amount of mass at each component, L is the length of the corresponding component. ρ is the density of the refrigerant, V is the volume of the component refrigerant flowing through.

For single phase flow, the equation 2.12 can be changed into:

$$m_i = A_i \int_0^L \rho dl \quad 2.13$$

A_i is the cross-section of each component, since the cross-section is normally not changing (not including capillary tube), the value of A_i is considered to be constant.

The concept of the equation above is: density times volume is the mass, since the cross-section is not changing (not including capillary tube), the variables are density and the length. The density can vary a lot through the whole system.

A two-phase homogeneous flow can be illustrated in the figure below:

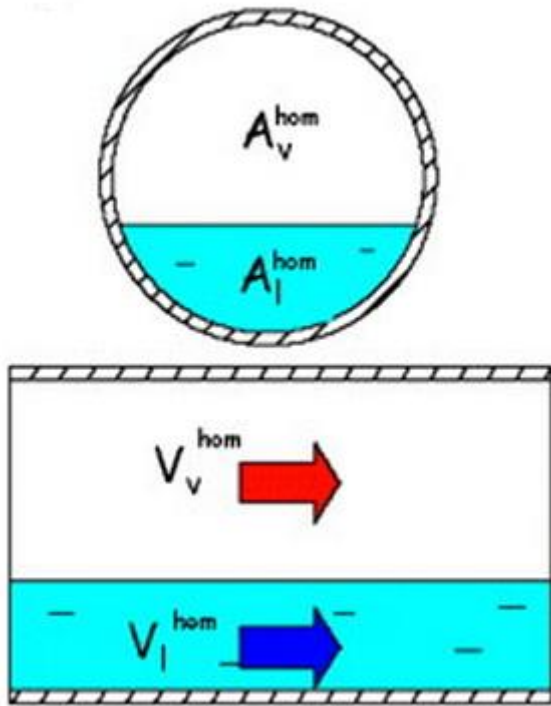

Figure 2. 8 Two-phase homogeneous flow

In this project, the two-phase homogeneous flow is in the evaporator and capillary tube.

For two-phase homogeneous flow, the equation can be written as below:

$$m_v = \int_0^L \rho_v dV_v = \rho_v \int_0^L A_v dl \quad 2.14$$

and

$$m_f = \int_0^L \rho_f dV_f = \rho_f \int_0^L A_f dl \quad 2.15$$

Where “v” represents the gas (vapor) phase and “f” represents the liquid phase. Since the refrigerant is in saturated state, the density is not changing through a two-phase homogeneous flow, only A_v and A_f is changing through the cross-section in evaporator and capillary tube.

3 practical information for experiments

3.1 components

3.1.1 Compressor

The compressor type used in this project is EK 6214CD, manufactured by Embraco. The EK series is specialized made for utilizing CO₂, Figures below shows the external look of this type of compressor.



Figure 3. 1 Compressor EK 6214CD



Figure 3. 2 EK 6214CD

Outer dimensions (data comes from the manufactory) for EK6214CD are shown in figure below.

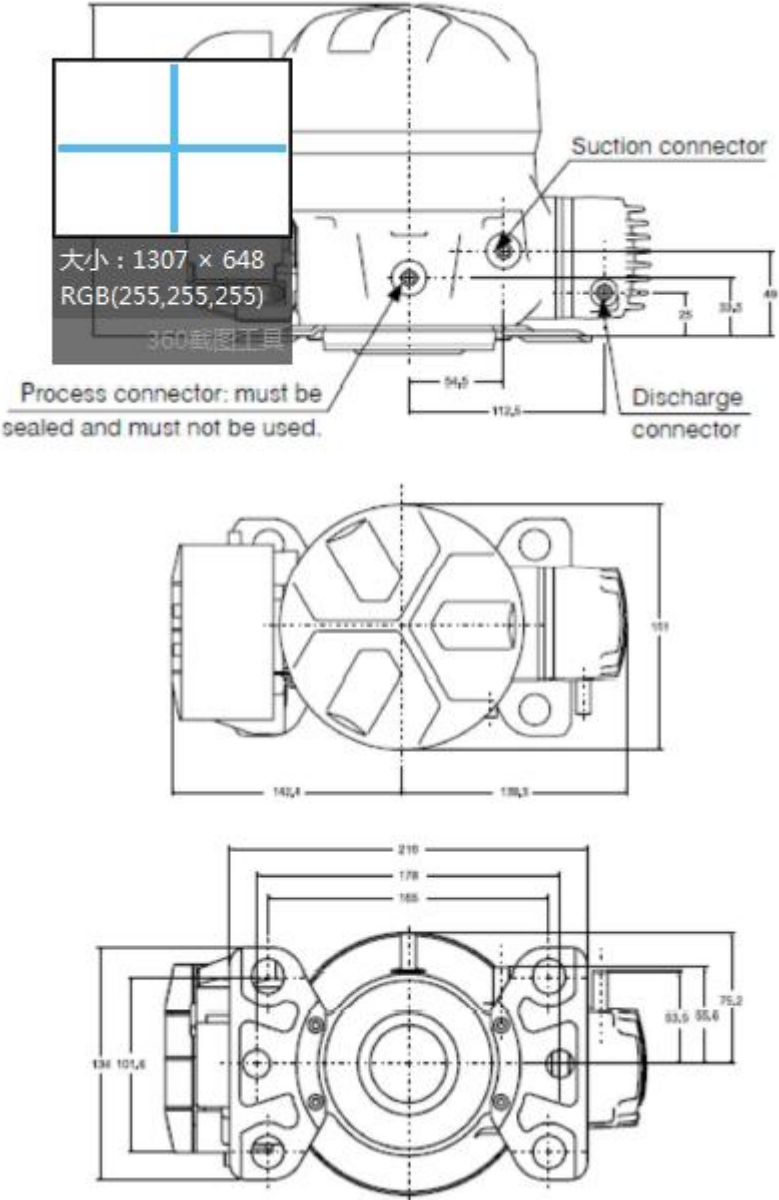

Figure 3. 3 Outer dimensions (data comes from the manufactory) for EK6214CD

Some of the basic specifications is listed below from the manufactory.

Basic Specifications

- Applications: light commercial (vending machines, bottle coolers, ice cream freezers), ice machines, heat pumps, dryers
- Design: single stage reciprocating compressor for M/HBP
- Voltage / Frequency: 220-240V 50Hz
- Displacement (cc): 2.45
- MBP cooling capacity (W): 905
- HBP cooling capacity (W): 1570

This compressor is a hermetic compressor. The motor and the compressor are enclosed in a welded steel casing, it makes it a compact unit and easy to carry. The motor will be cooled first after evaporator, and the refrigerant (CO₂) is heated (superheating) to make sure that there is no liquid sucking into the compressor. And since the compressor is relative small and light, it is possible to install into the drum dryer.

Refrigerant purity

The refrigerant purity recommended is listed below:

Purity Caron Dioxide	99.95% Vol.
Water Content	Max 20 wtppm
Nitrogen	≤ 5 ppm
Acid (Sulphur Dioxide)	0.1 wtppm

And other substances like chlorine, paraffin, silicone and solids residues must not come into the compressor, other substances then the ones listed above should not exceed 50% of what it is recommended in DIN 8964.

Moisture in the system

Moisture in the system can reduce the life of the system, table below shows the harm of moisture to the system.

1 Ice build-up	Reduces the cross-sectional area of the capillary tube, or expansion valve, up to their complete obstruction.
2 Acid build-up	Causes serious problems to the compressor and to the molecular sieve of the filter. Consequences: <ul style="list-style-type: none"> - Copper plating of valve plate, valve reeds, crankshaft bearings, etc. - Etching of electric motor insulation by acids, with burning of motor windings. - Destruction of the filter with disintegration of molecular sieve and build-up of dusts. - Wear of reciprocating and rotating parts.
3 Oil contamination	Causes acidification and reduction of its lubricating power, with change of oil colour (brown). It can cause build-up of sludge, with subsequent poor lubrication of compressor.

Table 3. 1 Contaminations[12]

‘After some small tests, the data is extracted from LABVIEW, it is noticed that the discharge temperature at compressor outlet is too low to be “true”, one of the assumption for causing this problem is that there is still liquid form of refrigerant just before compression, and the liquid form of refrigerant is cooling down the compressed gas, so it results in too low discharge temperature.

Oil charge

This compressor is charged with 150 cm³ lubricant oil, when injecting oil in the compressor, the maximum allowable humidity content in lubricant oil is 15 ppm. Since oil leakage can happen when for example, discharging CO₂, leaking out during operation through compressor, pipes, valves and during maintaining. Thus, a minimum amount of lubricant oil is set to be 100 cm³ to give enough sufficient lubrication to compressor when operating. The lack of oil can lead to wear, seizure of the mechanical parts.

Chose of expansion device for compressor

An expansion device should be chosen. In this project, a capillary tube is installed to the system. To ensure there is no liquid flowing into the compressor, a proper size of capillary tube should be tested. The operating condition should be considered when choosing the capillary tube.

Chose of gas cooler and evaporator

For gas cooler, hydrostatic pressure testes should be performed, and the burst pressure should meet IEC 60335-1 standard.

For evaporator, the mechanical strength should also meet IEC 60335-1 standard.

Pressure and temperature limitation

To keep the compressor running in good conditions, the maximum discharge pressure is 150 bars, and 120 bars is the limitation for the compressor to work in a normal condition. the recommended discharge pressure should be under 120 bars.

In case of fouling, expansion device problem, the compressor can be working in an abnormal condition. A safety valve with maximum 150 bars is installed at the outlet of the compressor, it will open if the discharge exceeds 150 bars.

The maximum temperature is 160 °C at compressor outlet, and the maximum suction temperature is 32 °C, it should be noticed that the temperature at evaporator outlet is not the same as the suction temperature at the compressor inlet. Here the compressor inlet temperature should be measured 200mm away from the suction tube because the gas will be heated by the compressor motor first when it flows into the compressor. So the gas is overheated before flowing into the compressor chamber.

Vacuum

Before charging CO₂ into the system, it is very important to vacuum the system. It is recommended to vacuum both side of the system, and the vacuum level should be below 0.05 mar. a proper vacuuming can ensure that the moisture and air is below the limits, thus preserve the working life of the compressor.

Refrigerant charge

The refrigerant charge is calculated based on the equation 2.11-2.15, the evaporation pressure is estimated as 45bars and high pressure side is estimated as 100 bars, the temperature before expansion is estimated as 39°C and the discharge temperature after compression is 95°C.

With the estimation above, the refrigerant charge is calculated as 0,356kg in total with the help of Excel and Coolpack. The basic method is to divide the whole process into several parts, each part has a certain average property values(property values is from Coolpack, CO₂ property values and hand calculation) for the refrigerant, with the property values the weight of the refrigerant can be calculated. The detailed calculation is in appendix C.

The calculated refrigerant charge is only used for first trial, this project is based the method "trial and error", so the optimized refrigerant charge will be found out after several testes, and the refrigerant charge will be expressed as mass flow[kg/s] instead of the total refrigerant charge[kg].

3.1.2 Evaporator

The evaporator is used to evaporate CO₂ from liquid phase to gas phase after expansion process, and also used to condense water vapor from the air flow from the drum.

The evaporator should be designed carefully, since CO₂ has a higher density than most of the refrigerant. A higher density means that a small volume of the refrigerant flow can give a relative large cooling capacity. And also the flow pattern can be different than most of the

conventional refrigerant. The design of the evaporator should also consider the mass flow rate, heat transfer, the selection of material for tubes and fins.

For both traditional evaporator or evaporator designed for CO₂, the larger area covered by liquid form of refrigerant, the larger heat transfer an evaporator can give, so for a high density refrigerant like CO₂, the diameter for tubes should be small and the length should be large.

The humid, warm air from the drum flows through the fins of the evaporator, and the water vapor will condense at the cold fins. The aluminum fins have hydrophobic coating covers so that the condensed water will become droplets instead of a film (a film can reduce the heat transfer). Then the droplets will be drained away by gravity and pumped out through a pipe. So the mass of the drained water can be measured.

A problem that can occur for this evaporator is that the system is not stable at the beginning of the operation, the CO₂ temperature after the expansion can be rising, so it will cause the evaporation temperature to rise too. With the increased evaporation temperature, the heat transfer and cooling capacity is lowered, and thus the water extraction rate. A proper refrigerant charge should be determined to keep the temperature level from rising too much for the whole system.

The details for the evaporator used in this projected is shown below:

The table below shows the dimensions of the evaporator.

Evaporator				
Main dimensions	unit	Tube bundle and lamellas		Unit
Core length	0,302 m	Tube diameter(s)	7,00/5.00	mm
Finned tube length	0,25 m	Fin thickness		0,15 mm
Core height	0,095 m	Fin spacing		2,69 mm
Core depth	0,136 m	Fin material	Aluminium(coated)	
Air side area	2,3 m ²	Tube material	Copper	
Tube inner area	0,245 m ²	Tube arrangement	Staggered down	
Area ratio	12,19 -	Number of vertical tubes		6
		Vertical tube pitch		15,75 mm
Total tube length	14,5 m	Number of horizontal tubes		8
		Horizontal tube pitch		17 mm

Table 3. 2 Evaporator geometry[11]

The figure below shows the drawing of the evaporator from inventor:

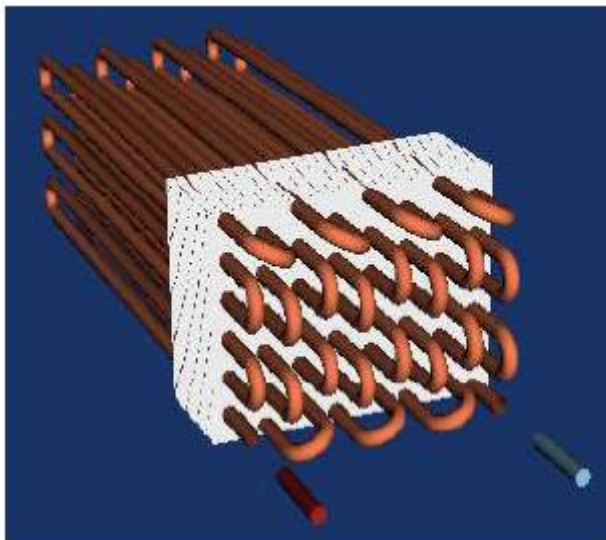

Figure 3. 4 Evaporator Hxsim 2007 visualization

The figure below shows how the refrigerant will flow inside the evaporator:

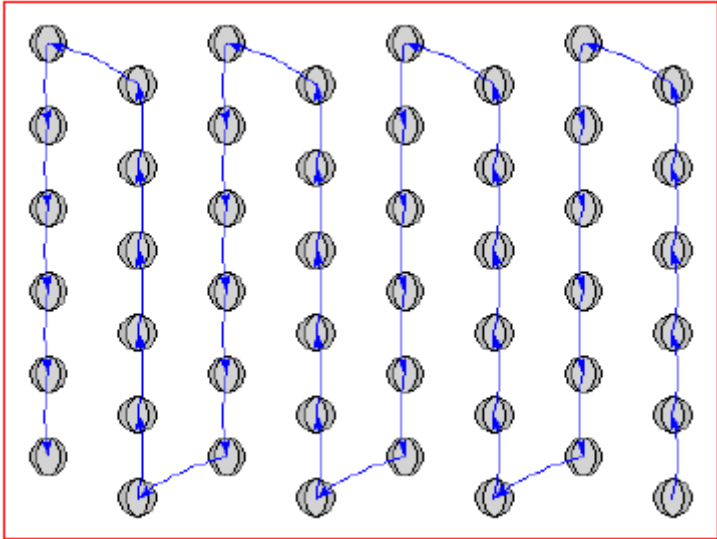

Figure 3. 5 Gas cooler HXsim 2007 flow distribution

The figures below shows how the evaporator looks like:



Figure 3. 6 Evaporator outlook

The figure below shows the outer dimensions from manufacturer:

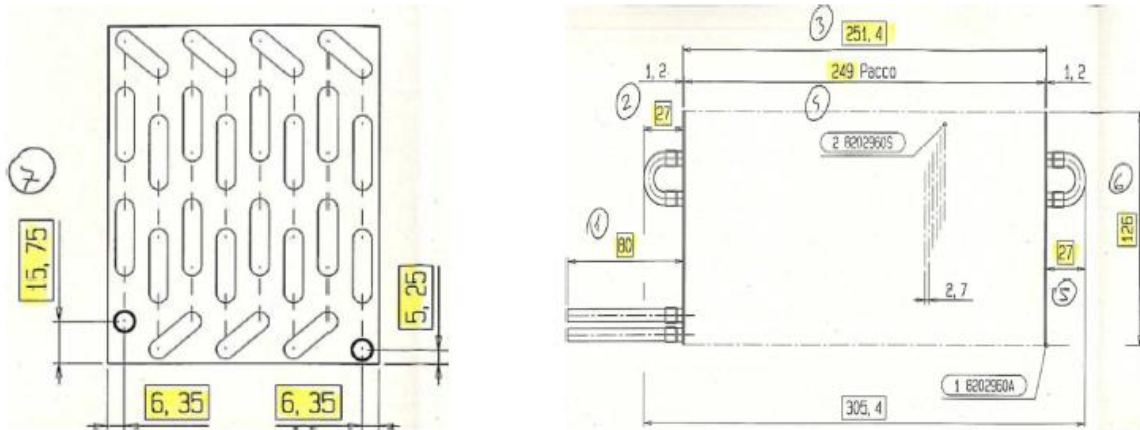

Figure 3. 7 Evaporator outer dimensions from manufacturer

3.1.3 Gas cooler

The gas cooler is connected to the compressor and external gas cooler at each end. Hot and compressed CO₂ in gas phase flows into gas cooler, and is cooled down in the gas cooler, in the mean time, the air flow is heated, and the humidity is decreasing since no water is coming into the air when passing through the gas cooler. CO₂ is further cooled down in an external gas cooler after the main gas cooler.

The type of gas cooler is HXsim 2007 and has been tested with pressures from 80-120 bars with varying temperatures with the result as below.

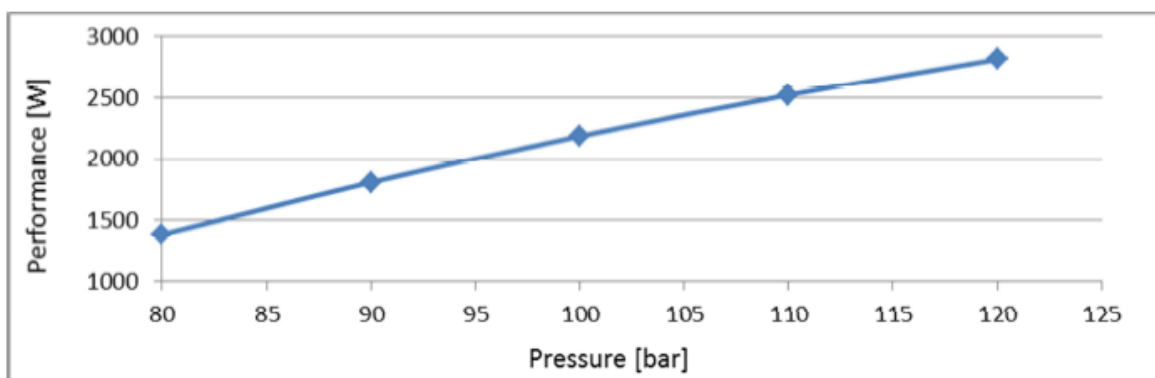

Figure 3. 8 Gas cooler simulated performance

From the test result above it can be seen that the performance of the gas cooler will increase with the increasing pressure. It is because that the increasing pressure results in increasing temperature, thus a better heat transfer rate.

For the test results below, it can be seen that with an increasing pressure of the CO₂, the temperature of the air is increased, and also an increasing outlet relative humidity, it is because that the air can contain more water with increased temperature. The temperature(or pressure) of the CO₂ should not be too big, because of the limitation of compressor, and also because too high temperature will damage the fabric.

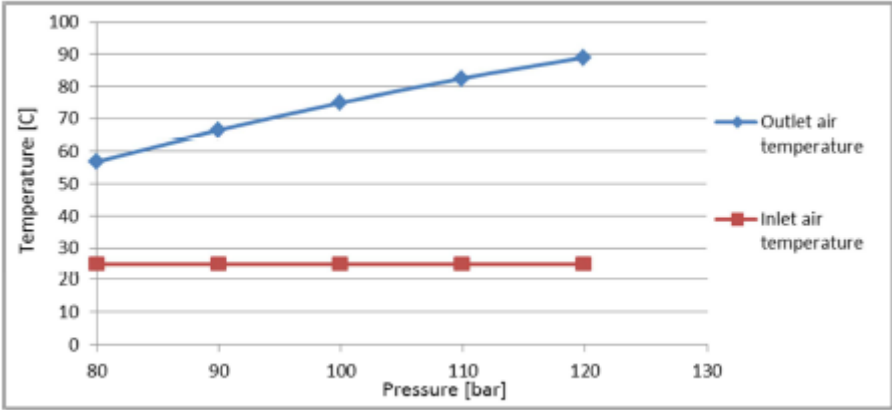

Figure 3. 9 Gas cooler inlet and outlet air temperatures

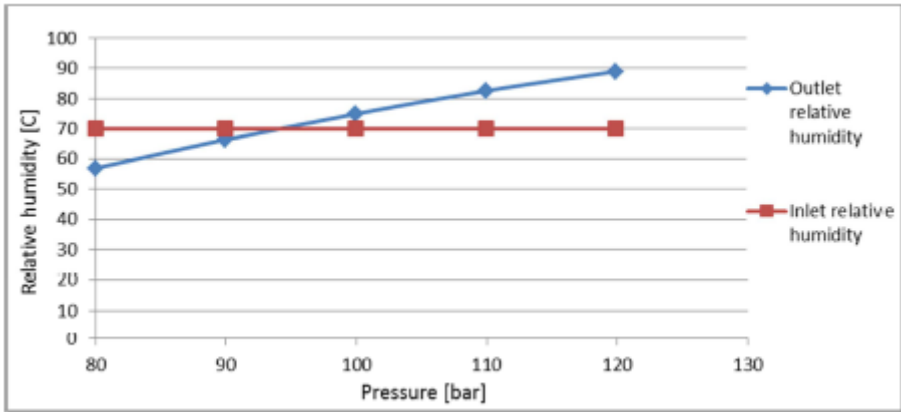

Figure 3. 10 Gas cooler inlet and outlet relative humidity

The table below shows the dimensions of the gas cooler:

Main gas cooler				
Main dimension		unit	Tube bundle and lamellas	Unit
Core length	0,302	m	Tube diameter(s)	7,00/5.00 mm
Finned tube length	0,248	m	Fin thickness	1,2 mm
Core height	0,085	m	Fin spacing	2,69 mm
Core depth	0,204	m	Fin material	Aluminium
Air side area	2,91	m ²	Tube material	Copper
Tube inner area	0,351	m ²	Tube arrangement	Staggered up
Area ratio	10,37	-	Number of vertical tubes	6
			Vertical tube pitch	13 mm
Total tube length	24,74	m	Number of horizontal tubes	12
			Horizontal tube pitch	17 mm

Table 3. 3 Main gas cooler dimensions[11]

Figures below shows the outlook of the gas cooler:

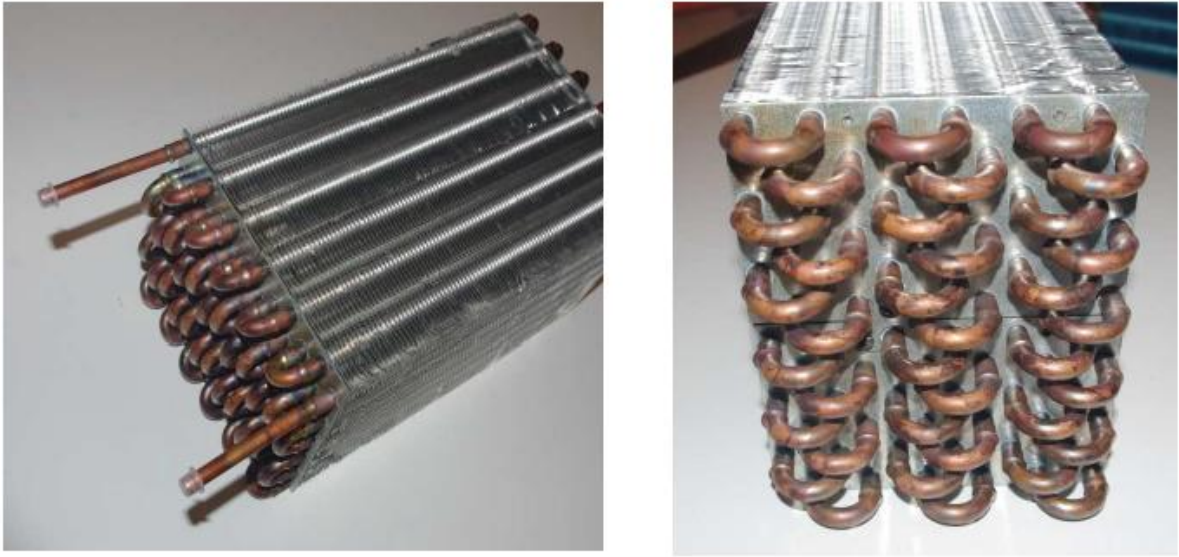

Figure 3. 11 Main gas cooler

Figure below shows the flow distribution:

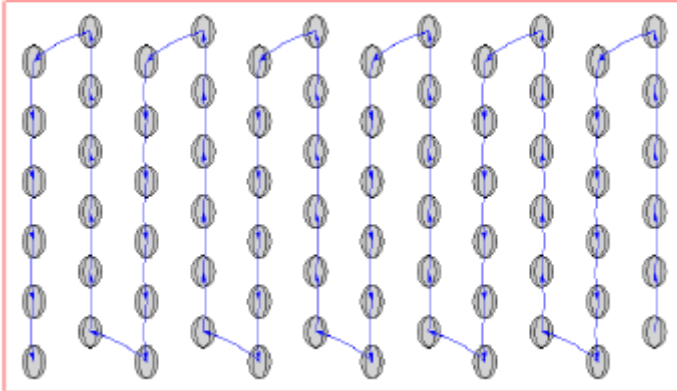

Figure 3. 12 Main gas cooler flow distribution

Figure below shows the drawing from inventor:

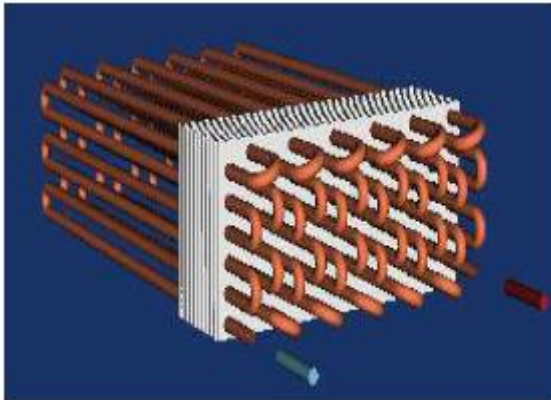

Figure 3. 13 Gas cooler HXsim 2007 visualisation

3.1.4 External gas coolers

The external gas coolers are connected to the main gas cooler and the capillary tube, the point of adding external gas coolers is because a lowered temperature at high pressure side before capillary tube will increase the cooling capacity, thus possibility to increased overall efficiency.

The external gas coolers consists two heat exchangers: one big heat exchanger and one small heat exchanger. These two heat exchangers are connected in series. A two-way valve, which is a valve with one inlet pressure port that can serve one of the outlets by controlling the position of the valve, is installed so that it can be chosen that CO₂ flows through the big heat exchanger, small heat exchanger or two heat exchangers connected together in series.

The two heat exchangers are placed on the top of the drum, and a fan is installed at the end of the small heat changer shown in figure below, so the air can be blew through the heat exchangers while CO₂ flows through the tubes on the other side, thus a countercurrent flow to make the heat transfer more efficient.



Figure 3. 14

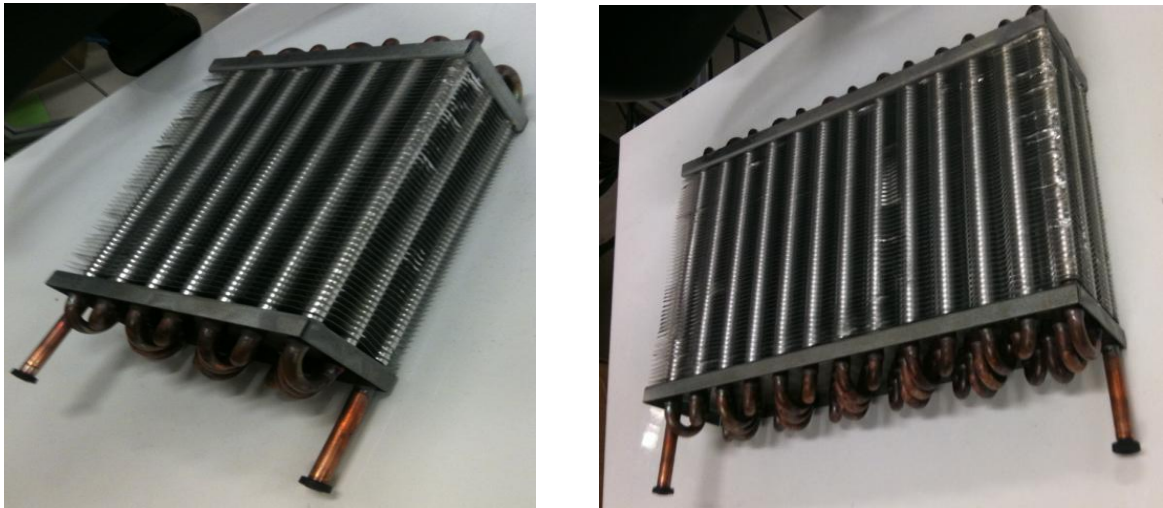

Figure 3. 15 Small and large external gas cooler

The dimensions of the two heat exchangers are shown in figure below:

MAIN DIMENSIONS:		TUBE BUNDLE AND LAMELLAS:	
Core length	: 0.116 m	Tube diameter(s)	: 7.20 / 5.80 mm H
Finned tube length:	0.064 m		: 7.20 / 5.80 mm V
Core height	: 0.063 m	Fin thickness	: 0.12 mm
Core depth	: 0.292 m	Fin spacing	: 3.88 mm
Air side area	: 0.60 m ²	Fin material	:Aluminum
Tube inner area	: 0.187 m ²	Tube material	:Copper
Area ratio	: 7.42 -	Tube arrangement	:Staggered_down
		Number of vertical tubes	: 3
Core weight	: 1.713 kg	Vertical tube pitch :	21.00 mm
Tube weight	: 1.633 kg	Number of horizontal tubes :	23
Fin weight	: 0.081 kg	Horizontal tube pitch:	12.70 mm

Table 3. 4 Large external gas cooler dimensions

The large heat exchanger:

MAIN DIMENSIONS:		TUBE BUNDLE AND LAMELLAS:	
Core length	: 0.116 m	Tube diameter(s)	: 7.20 / 5.80 mm H
Finned tube length:	0.064 m		: 7.20 / 5.80 mm V
Core height	: 0.063 m	Fin thickness	: 0.12 mm
Core depth	: 0.152 m	Fin spacing	: 3.88 mm
Air side area	: 0.31 m ²	Fin material	:Aluminum
Tube inner area	: 0.098 m ²	Tube material	:Copper
Area ratio	: 7.42 -	Tube arrangement	:Staggered_down
		Number of vertical tubes	: 3
Core weight	: 0.895 kg	Vertical tube pitch :	21.00 mm
Tube weight	: 0.853 kg	Number of horizontal tubes :	12
Fin weight	: 0.042 kg	Horizontal tube pitch:	12.70 mm

Table 3. 5 Small external gas cooler dimensions

The fan used to blow air through the external heat exchangers:



Table 3. 6

3.2 safety and operating guidelines

The CO₂ heat pump system is not much different from conventional heat pump systems using other refrigerant, some extra rules should be followed because of the high temperature and pressure.

3.2.1 Effects on human

As mentioned above, CO₂ is odorless, which makes it hard to notice if there is leakage. For domestic purpose of use, if the concentration in air is around 2%, people can get inhaled. The symptom can get more serious if the concentration is higher. The table below shows the effects and symptoms with different level of CO₂ concentration.

Conc. in air	Effects and Symptoms
2%	50% increase in breathing rate
3%	10 Minutes short term exposure limit; 100% increase in breathing rate
5%	300% increase in breathing rate, headache and sweating may begin after about an hour (Com.: this will tolerated by most persons, but it is physical burdening)
8%	Short time exposure limit
8-10%	Headache after 10 or 15 minutes. Dizziness, buzzing in the ears, blood pressure increase, high pulse rate, excitation, and nausea.
10-18%	After a few minutes, cramps similar to epileptic fits, loss of consciousness, and shock (i.e.; a sharp drop in blood pressure) The victims recover very quickly in fresh air.
18-20%	Symptoms similar those of a stroke

Table 3. 16 Effects on humans

In case there is leakage, several things should be done to avoid accumulation of CO₂ or human damage:

- Ventilation should be provided. A good ventilation system should be installed at the room where CO₂ heat pump system is operating.
- Don't stay around the system if there is a big leakage of CO₂, wait until you are sure the CO₂ concentration is low enough.
- It should be sensors to detect the CO₂ concentration.
- CO₂ cylinder that contains CO₂ should stand upright when charging the CO₂ heat pump system, since the cold CO₂ can form a thick mist with moist air.
- Person who is exposed to high CO₂ concentration should be taken into open air as soon as possible, artificial respiration should be carried out if the person is inhaled or in coma.

3.2.2 Metal compatibility

Metal compatibility should be taken into consideration when the CO₂ heat pump is installed/repared. The table below shows the compatibility when CO₂ is in contact with

different metals. Data from the table comes from International Standards: Compatibility of cylinder and valve materials with gas content; Part 1: ISO 11114-1 (Jul 1998), Part 2: ISO 11114-2 (Mar 2001)

This table shows mainly the compatibility for different metals rather than the quality of the metals. In this project, no plastics, elastomers or ferritic steels is used or in contact with CO₂. So there is no danger based on compatibility.

Material	Compatibility
Metals	
Aluminium	Satisfactory
Brass	Satisfactory
Copper	Satisfactory
Ferritic Steels (e.g. Carbon steels)	Satisfactory but risk of corrosion in presence of CO and/or moisture, Cold brittleness.
Stainless Steel	Satisfactory
Plastics	
Polytetrafluoroethylene (PTFE)	Satisfactory
Polychlorotrifluoroethylene (PCTFE)	Satisfactory
Vinylidene polyfluoride(PVDF) (KYNAR™)	Satisfactory
Polyamide(PA) (NYLON™)	Satisfactory
Polypropylene(PP)	Satisfactory
Elastomers	
Buthyl (isobutene - isoprene) rubber (IIR)	Non recommended, significant swelling.
Nitrile rubber (NBR)	Non recommended, significant swelling and significant loss of mass by extraction or chemical reaction.
Chloroprene (CR)	Non recommended, significant swelling and significant loss of mass by extraction or chemical reaction.
Chlorofluorocarbons (FKM) (VITON™)	Non recommended, significant swelling and significant loss of mass by extraction or chemical reaction.
Silicon (Q)	Acceptable but strong rate of permeation.
Ethylene-Propylene (EPDM)	Acceptable but important swelling and significant loss of mass by extraction or chemical reaction.
Lubricants	
Hydrocarbon based lubricant	Satisfactory
Fluorocarbon based lubricant	Satisfactory

Table 3. 7 Metal compatibility [10]

3.2. Operating pressures and temperatures

The drum dryer is designed to operate in normal conditions, so the evaporating temperature won't be lower than 0 °C, so the danger caused by low temperature can be ignored.

However, for a high refrigerant charge after a long-time running, the discharge temperature at compressor outlet can be very high, up to 80 or 90 °C. Although too high refrigerant charge is not recommended, the risk is present. So the human contact to the piping after compressor outlet should be avoided.

3.3 Pressure at standstill

For conventional refrigerant systems, the standstill (when the system is not operating) pressure is normally below 40 bar and in liquid phase, for example: HFC, HCFC. However for CO₂ as refrigerant at standstill, for different room temperature, the pressure can be relative high, and in saturated state.

The CO₂ heat pump system is tested in a lab, the temperature is between 18 °C during winter and 25 °C during summer, from the R744 P-H diagram below, it can be seen that if the pressure is up to 55 bars and the room temperature is 18 °C, the refrigerant inside the system is in saturated state, and if the temperature is 25 °C, the refrigerant is in saturated state when the pressure is up to around 64.5 bars. The refrigerant is in supercritical region if the temperature is higher than 31 °C, and the pressure can be up to 75 bars.

Whether the refrigerant at standstill is in saturated state depends also on the refrigerant charge, the lower the refrigerant charge is, the less possibility is for refrigerant to be in saturated state. In this project, since the volume of the high pressure side is high, so when the system is shut down, and the refrigerant is cooled down to ambient temperature, the refrigerant is normally in saturated state. (Reducing refrigerant charge is bad for system efficiency, so it is not recommended.)

When the refrigerant is in saturated state and the pressure in the system is high, the liquid can be drained into the compressor. So when the compressor is starting, the liquid form of

refrigerant can damage the compressor, although it is for a short time. And the high pressure at standstill gives a higher possibility to leakage compared to conventional system using other refrigerant.

4 Results and discussion

4.1 Instrument overview

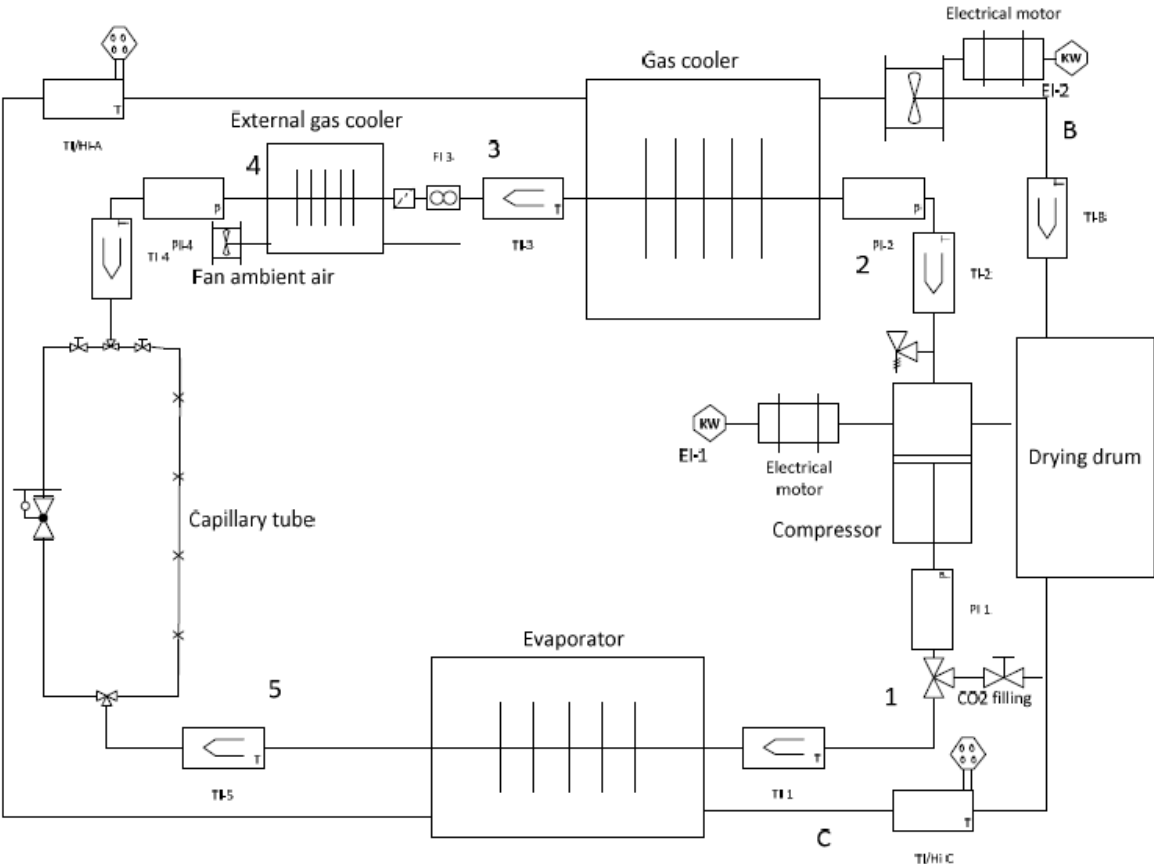

Figure 4. 1 Instrument overview

The newly installed gas coolers are shown below:

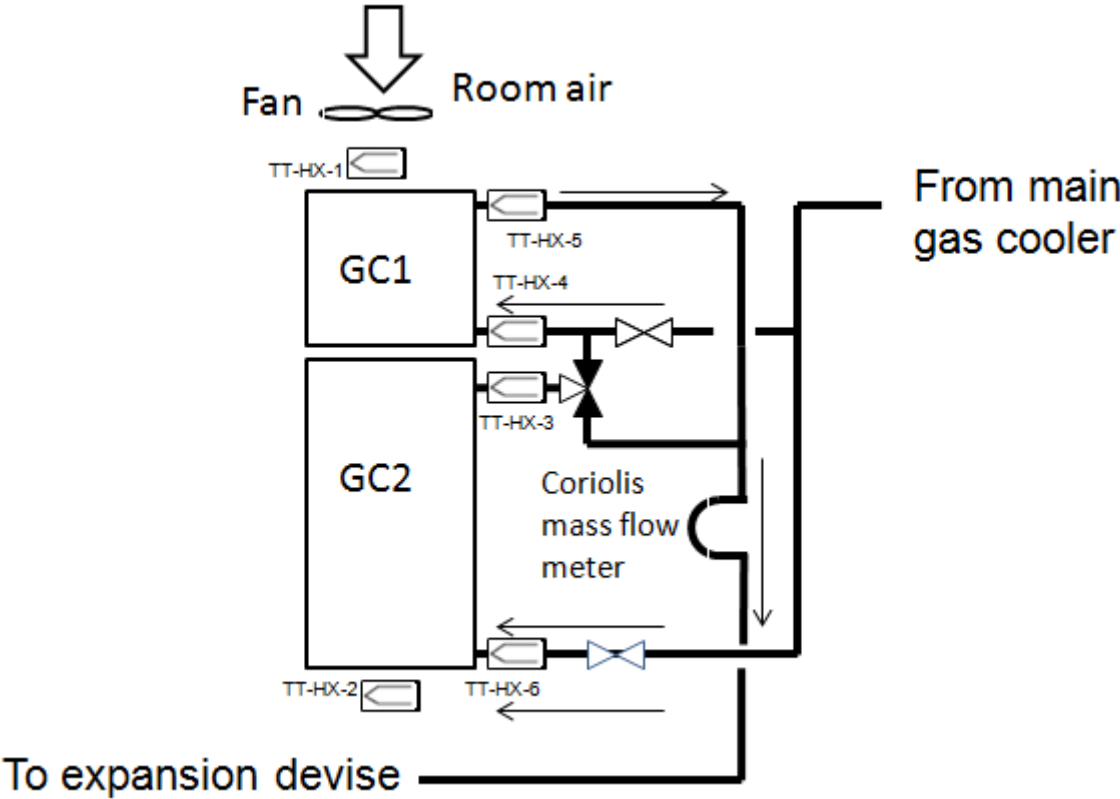

Figure 4. 2 External gas cooler

4.2 Experiments overview

Experiment description

Experiment nr.1	Small external gas cooler connected during the whole test(high refrigerant charge)
Experiment nr.2	Small external gas cooler connected after 30 minutes (high refrigerant charge)
Experiment nr.3	Small external gas cooler connected after 60 minutes(high refrigerant charge)
Experiment nr.4	Large external gas cooler connected during the whole test (reduced refrigerant charge)
Experiment nr.5	Large external gas cooler connected after 30 minutes (reduced refrigerant charge)
Experiment nr.6	Large external gas cooler connected after 60 minutes (reduced refrigerant charge)
Experiment nr.7	Small external gas cooler connected during the whole test (reduced refrigerant charge)
Experiment nr.8	Small external gas cooler connected after 30 minutes (reduced refrigerant charge)
Experiment nr.9	Large and small external gas coolers connected in series during the whole test (reduced refrigerant charge)
Experiment nr.10	Large and small external gas coolers connected in series after 30 minutes (reduced refrigerant charge)

Table 4.1 Experiment description

Symbols

The symbols used in the experiments will be list below:

Symbols	Description
PI-1	Evaporation pressure
PI-2	Pressure at compressor outlet
PI-4	Pressure at gas cooler outlet
T1	Temperature at evaporator outlet
T3	Temperature at main gas cooler outlet
T4	Temperature at external gas cooler outlet
T5	Temperature at compressor outlet
TT-HX-1	Air temperature at external gas cooler inlet
TT-HX-2	Air temperature at external gas cooler outlet
TT-HX-3	Temperature at large external gas cooler inlet
TT-HX-4	Temperature at small external gas cooler inlet
TT-HX-5	Temperature at small external gas cooler outlet
TT-HX-6	Temperature at large external gas cooler outlet
RH-out	The relative humidity of the air flow after the drum
RH-in	The relative humidity of the air flow before the drum
T_out	Air temperature out of the drum
T_in	Air temperature before the drum
T_mid	Air temperature after evaporation

Table 4.2 Symbols

4.3 Experiment result and analysis

For all the experiments the fabric and the water split over the fabric are weight to be 5,072kg and 3,043kg, respectively. Those amounts of fabric and water is to match the experiments carried out at ASKO, at which same amount of fabric and water is used to test the heat pump performance using R134a as refrigerant.

4.3.1 Experiment nr.1

This experiment is carried out with the (extra) small gas cooler connected with system, and the fan is blowing ambient air through the small gas cooler through the whole experiment. The point of this experiment is to see how a small gas cooler will affect the performance of the system.

Figure below shows the pressure at evaporator (PI-1), compressor outlet (PI-2), small gas cooler outlet (PI-4) over the time. This experiment lasts around 105 minutes.

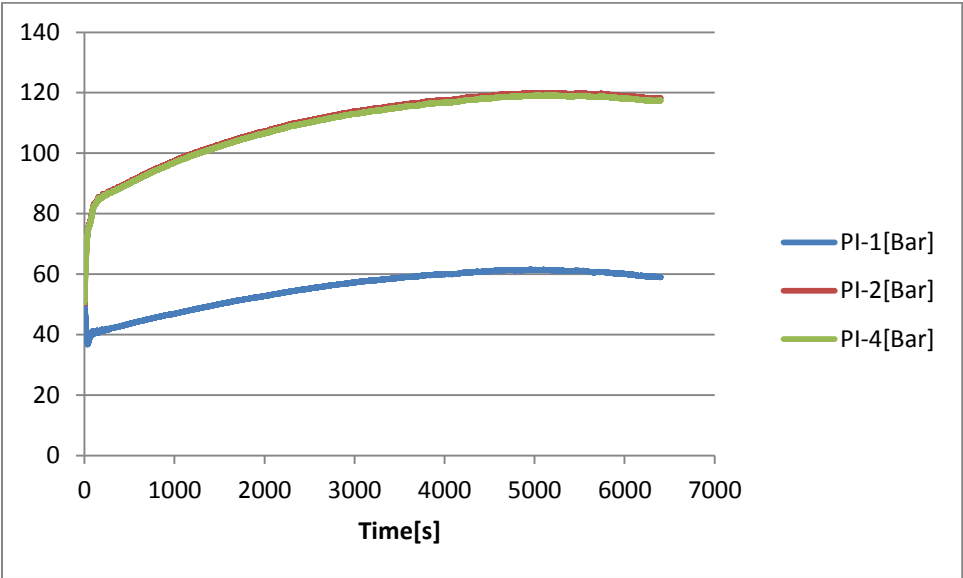

Figure 4. 3

From the figure above it can be seen PI-1, PI-2, PI-4 keep building up, and slows down after 60 minutes and peak at after around 81 minutes, goes slightly down to 118 bars after several minutes while the relative humidity is dropping. The pressure difference between the discharge pressure (PI-2) and the external gas cooler (PI-4) is between around 0,3 bar at the beginning to 1 bar when the pressures peaks at around 81 minutes and then goes down to 0,7 bar at the end, the general the pressure drop is considered to be not high, the pressure loss through the small gas cooler is not high either. The maximum discharge pressure (PI-2) for the compressor to be working normal is 120 bars, the peak pressure is around 120 bars, so the peak pressure is at the edge of the maximum pressure.

Figure below shows the CO₂ temperatures at evaporator outlet, compressor outlet, external gas cooler inlet and outlet. It can be noticed that it is the same tendency as pressure distribution, temperature rises with time, and peaks at around 81 minutes.

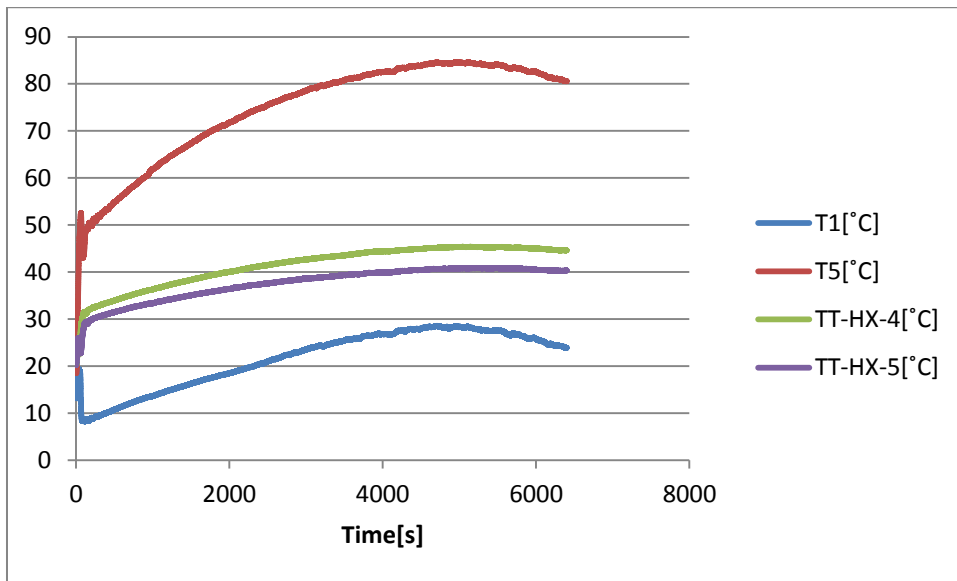

Figure 4. 4

Figure below shows the inlet and outlet relative humidity of the drum over time. The relative humidity can be defined as the ratio of the water vapor mass to the saturated water vapor mass in the air-water mixture.

The value of the relative humidity RH_out keeps relative constant (around 87%) until after 50 minutes, and it begins to drop. It can be noticed that the rate of temperature and pressure rise is also slowing down, and begins to drop at 81 minutes. Since the relative humidity represents the water content in the air-water mixture, lowered value of relative humidity means fewer water vapor droplets condense on the surface of the evaporator, which gives a lowered heat transfer between evaporator and the humid air flow, thus the outlet temperature of CO₂ is reduced after around 81 minutes, measured peak value of T1 is around 28°C at 81 minutes and drops to 24°C at the end. And at the same time the relative humidity out of the drum is dropped to around 42%. The fabric was taken out, and it was enough dried off.

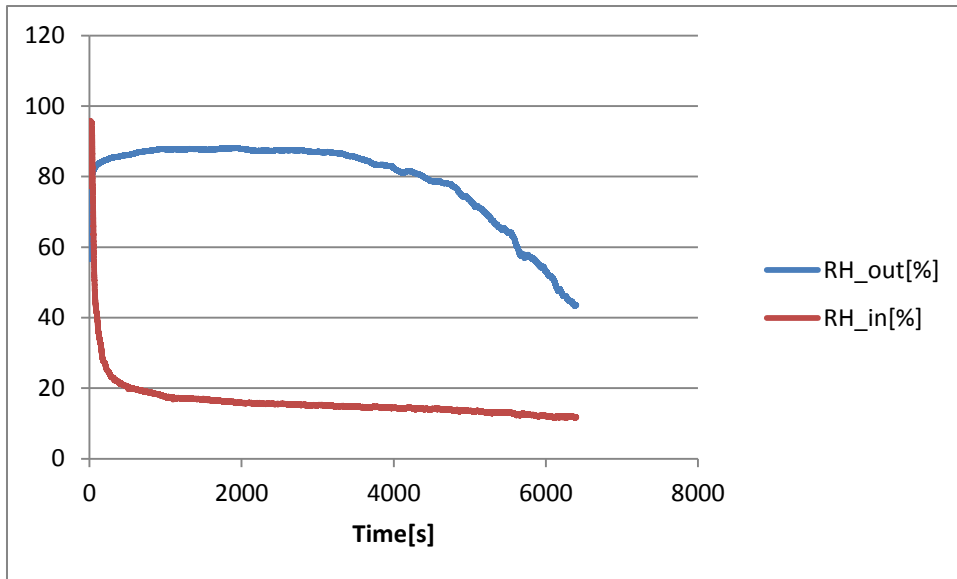

Figure 4. 5

Figure below shows the power consumption of the compressor and the motor used to run the drum. The compressor power consumption starts at around 610W and peaks at around 922W. And it can be seen that the power consumption of the compressor shares a similar tendency as the pressure and temperature diagram shown above.

PS: The drum power consumption starts 214W and drops to 191W at the end, it could be because the heated drum influences the working condition in a certain level, but since this project is focused on the CO₂ heat pump and the variation of the drum power consumption is not large, so this phenomenon won't be studied.

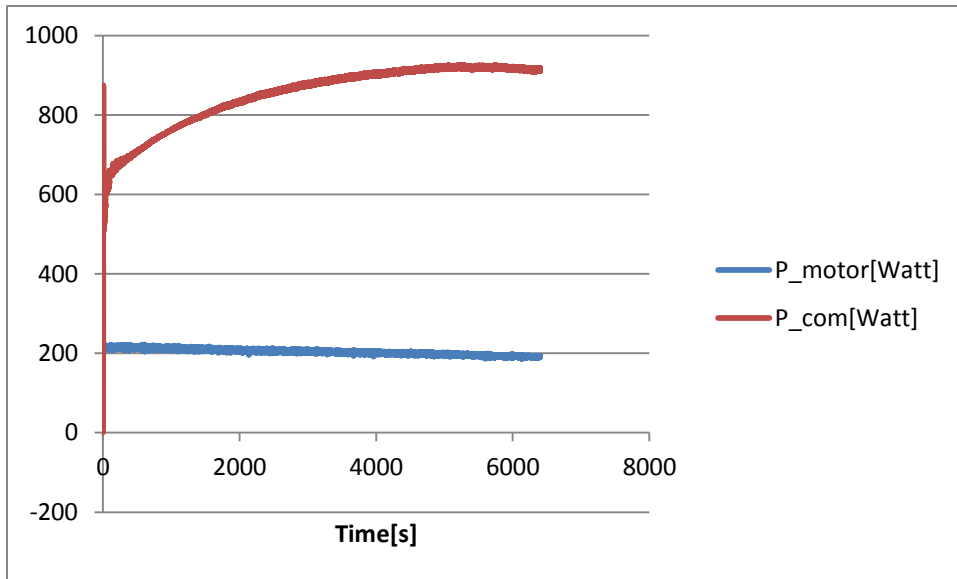

Figure 4. 6

Figure below shows the air temperature before drum, after drum and after flowing through evaporator. The inlet temperature T_{in} rises from the room temperature to 60°C . Temperature in the drum can be up to 100°C in the modern clothes dryers, and if the temperature of the warm is before 70°C , most fabric will in general not be damaged. Here the maximum temperature (60°C) is not considered as too high temperature, and will not damage the fabric. The difference between air temperature after drum and air temperature after evaporator is rising from around 7°C to 10°C .

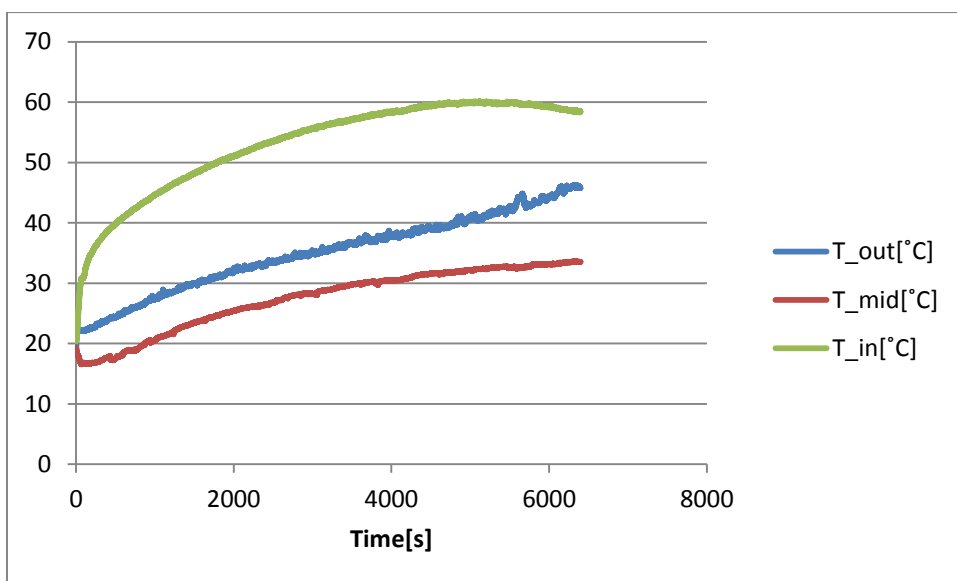

Figure 4. 7

Figure below shows the temperature difference between the inlet and outlet temperature of the air flowing through the external gas cooler. Since the CO₂ temperature at inlet and outlet of external gas cooler is always small, this diagram can be an indication of how well the heat transfer is for the external gas cooler, and will be compared with other experiments. In this experiment the temperature difference rise from zero to 18°C.

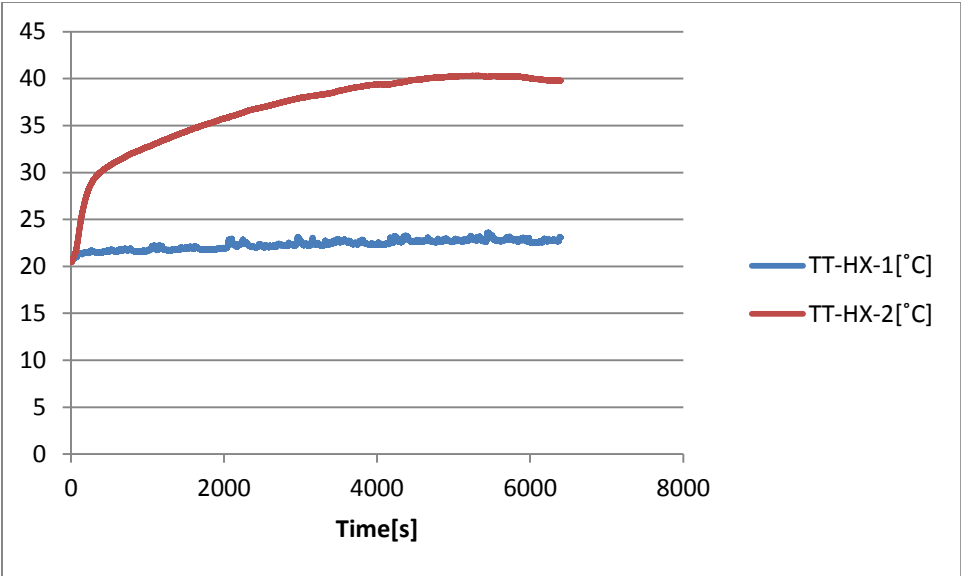

Figure 4. 8

In this project some data is extracted to calculate the performance of the evaporator, main gas cooler, external gas cooler, overheating and the COPs, and some data is extracted to draw p-h diagrams, the principle is to give a performance overview of chosen component and the heat pump system as a whole and the data is extracted when the system is relative stable.

Figure below shows cooling capacity of the evaporator, heating capacity of the main gas cooler and heating capacity of the external gas cooler. It can be noticed that the cooling capacity is decreasing over time, and the heating capacity for the main gas cooler and external gas cooler is increasing over time, it is because the temperature level at each component is increasing over time. So the heating capacity is increasing and cooling capacity is decreasing.

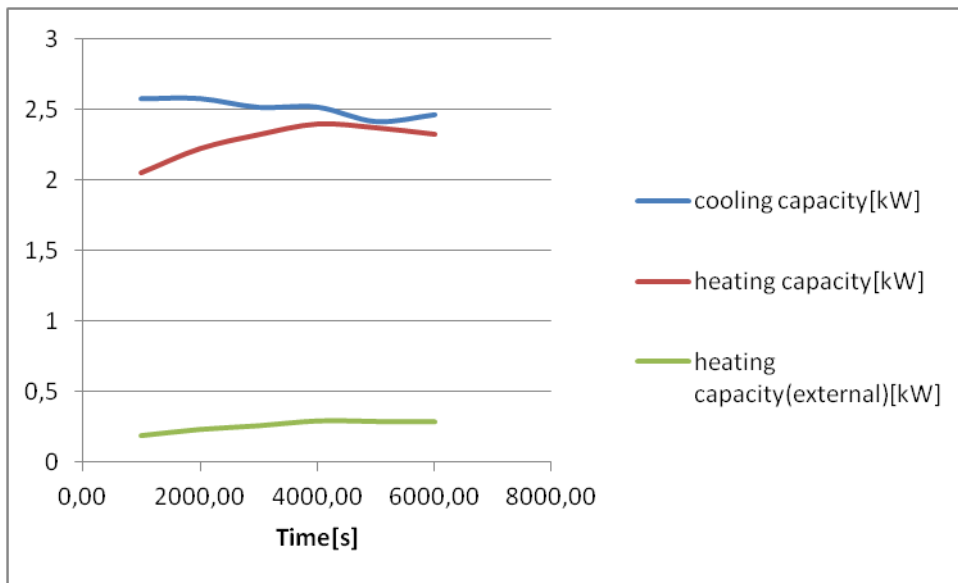

Figure 4. 9

Figure below shows the overheating before compression. This diagram is an indication of how much heat is added to the refrigerant after saturated gas line and before compression, a certain level of overheating is needed to prevent liquid form of CO₂ coming into the compressor, too much overheat will increase the compressor power consumption.

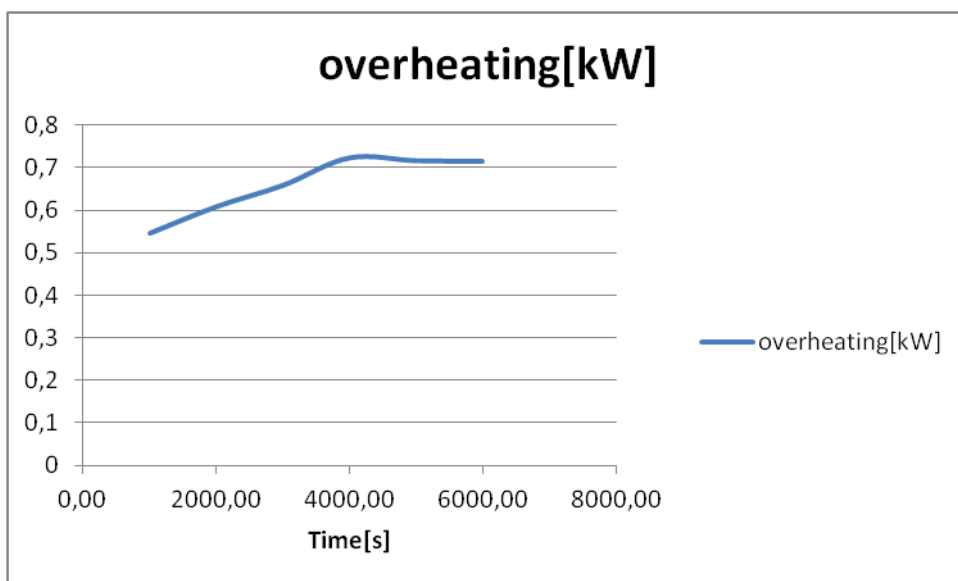

Figure 4. 10

Figure below shows the COP for the heating capacity and cooling capacity. These two values are good indicators of the heat pump system performance. The COP_cooling is calculated by the cooling effect of the evaporator divided by the compressor effect (to simplify the calculation, the effect of the fan used to blow air through external gas cooler is not included in the calculation since the effect of the fan is only 12watt, which is much less than the compressor effect), the COP_heating is calculated by the heating effect of the main gas cooler divided by the compressor effect.

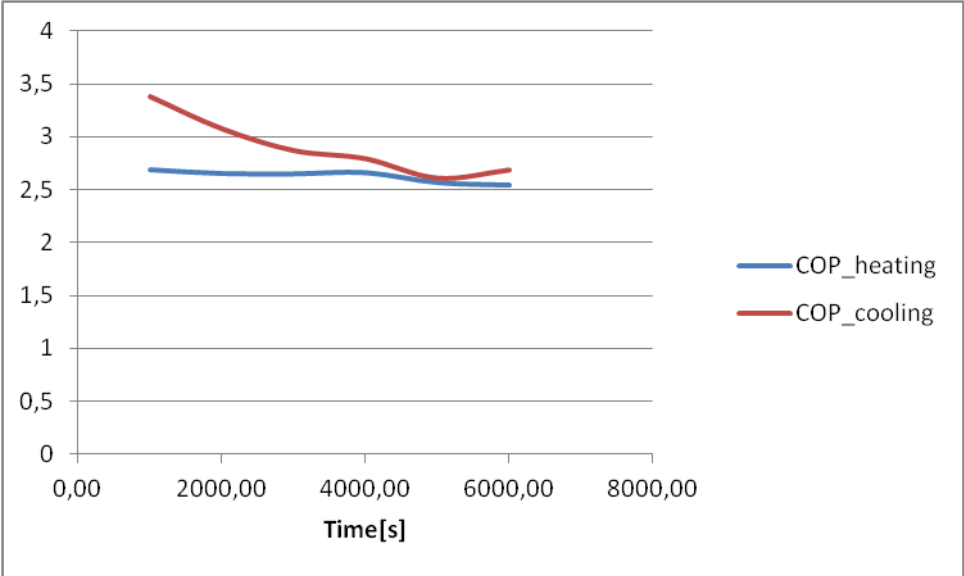

Figure 4. 11

Table below shows some of important summing-up values for this experiment.

Result values	
Water extracted	2,58 kg
Running time	105 minutes
COP_average(cooling)	2,198274
COP_average(heating)	1,988168
Compressor effect	0,850741 kW
Motor effect	0,203588 kW
Total effect	1,054329 kW
Mass flow	999 kg/min
Total power consumption	1,876 kWh
SMER	1,375267 kg/kWh

Table 4.3

4.3.2 Experiment nr.2

This experiment is carried out with a mall external gas cooler connected after 30 minutes (high refrigerant charge), it is to see how the performance of the system when there is no extra cooling of the refrigerant at the high pressure side. It is expected with better heating capacity than experiment nr.1.

Figure below shows the pressure at evaporator (PI-1), compressor outlet (PI-2), external gas cooler outlet (PI-4) over the time. It can be seen that the pressure level boost up to almost 140 bars at 30 minutes at high pressure side, and 69.5 bars at low pressure side(evaporation pressure), the critical pressure is 73.5bars and the evaporation pressure is very near that point.

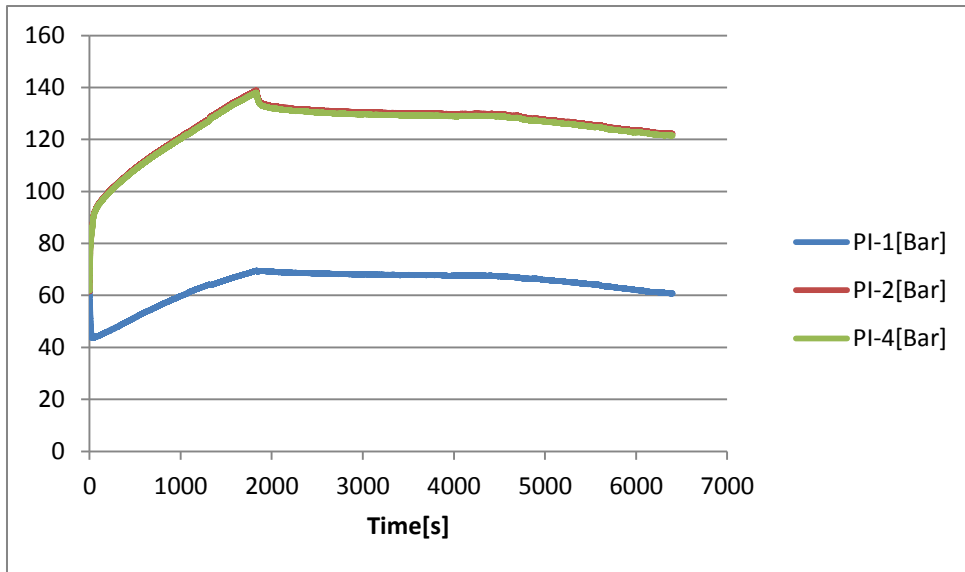

Figure 4. 12

Figure below shows the CO₂ temperatures at evaporator outlet, compressor outlet, external gas cooler inlet and outlet. This figure share the same tendency as pressure diagram above, the temperature at inlet and out of the external gas cooler is zero before 30 minutes since the external gas cooler is not cooled by air.

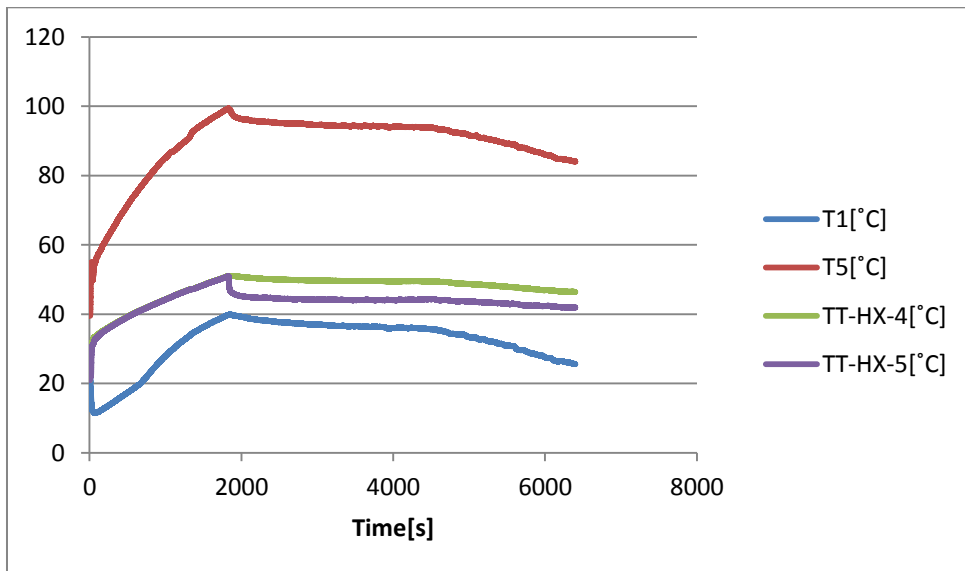

Figure 4. 13

Figure below shows the inlet and outlet relative humidity of the drum over time. The relative humidity is dropping after 30 minutes, this is because the high temperature of the air with ability to carry more water vapor than experiment.1

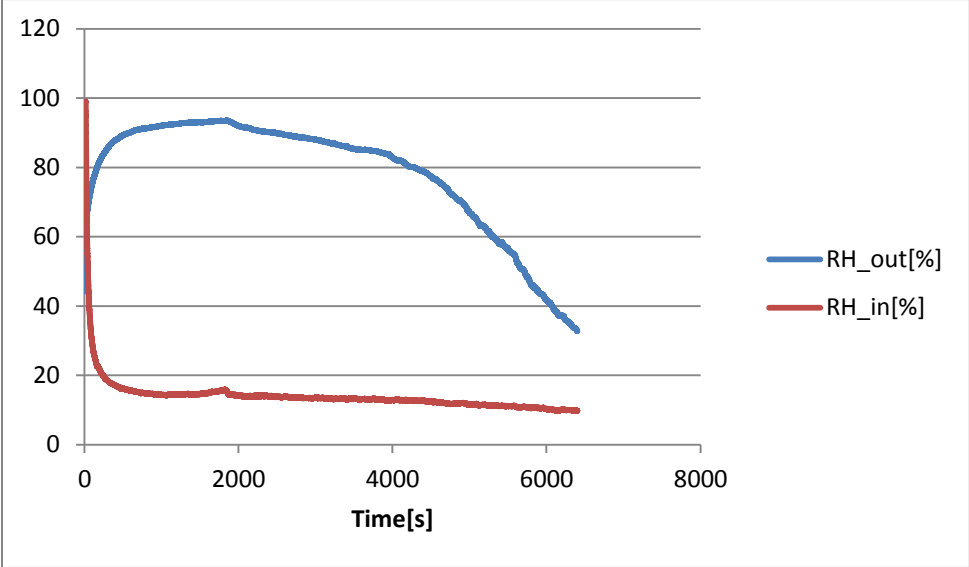

Figure 4. 14

Figure below shows the power consumption of the compressor and the motor used to run the drum. The power consumption is relative high compared to experiment nr.1, it peaks around 1kw at 30 minutes, and begins to drop after 30 minutes, and begins to drop more rapidly after the relative humidity is dropping rapidly, which is at 66 minutes.

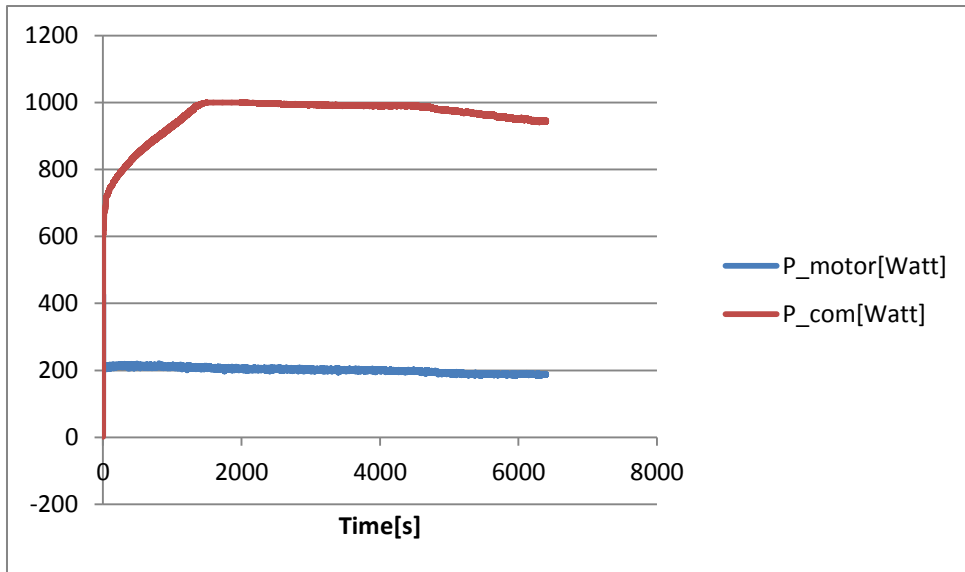

Figure 4. 15

Figure below shows the air temperature before drum, after drum and after flowing through evaporator. It can be noticed that after 30 minutes the air temperature outlet of the drum is dropping, which means that the ability to absorb water is less.

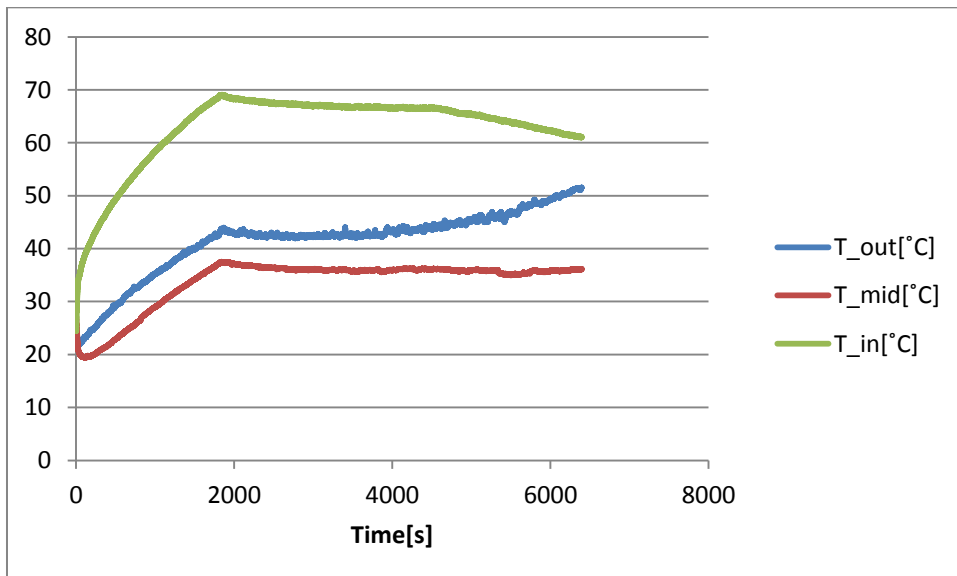

Figure 4. 16

Figure below shows the temperature difference between the inlet and outlet temperature of the air flowing through the external gas cooler. Although the external gas cooler is not cooled by

air, it can be noticed that there is still temperature difference between air inlet and outlet before, it is because one of the sensors is near the warm tube of external gas cooler, the other one is relative far away. The temperature difference after 30 minutes is dropping from 20°C to 17°C, which is similar to experiment nr.1

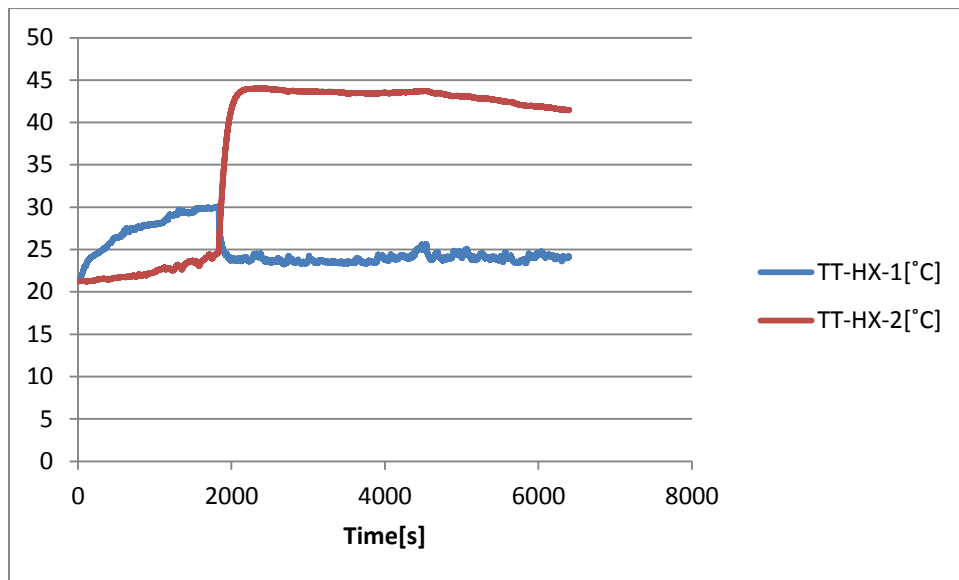

Figure 4. 17

In this project some data is extracted to calculate the performance of the evaporator, main gas cooler, external gas cooler, overheating and the COPs, and some data is extracted to draw p-h diagrams, the principle is to give a performance overview of chosen component and the heat pump system as a whole and the data is extracted when the system is relative stable.

Figure below shows cooling capacity of the evaporator, heating capacity of the main gas cooler and heating capacity of the external gas cooler. As expected, the heating capacity is higher than experiment nr.1, while the cooling capacity is lower.

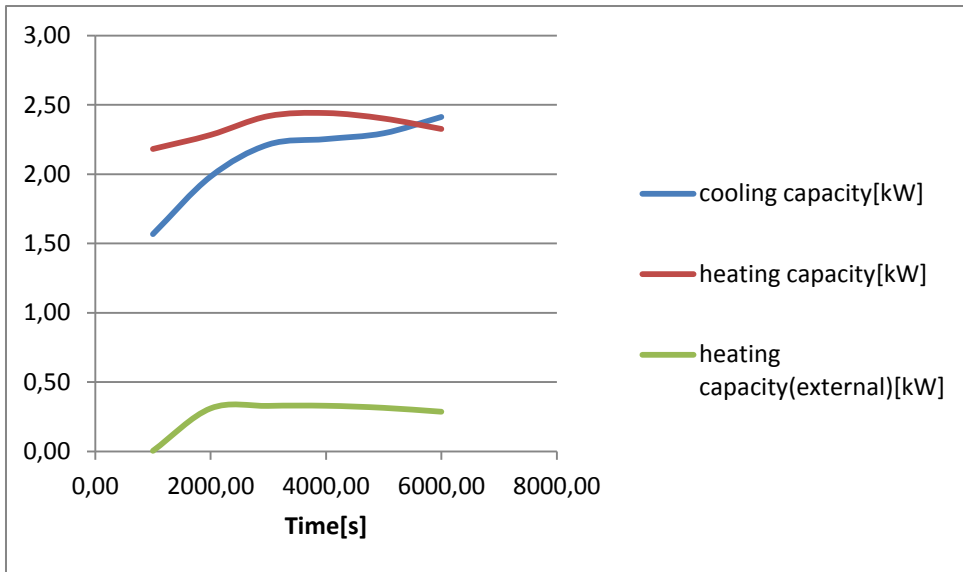

Figure 4. 18

Figure below shows the overheating before compression. It can be noticed that the overheating is increasing very faster compared to experiment nr.1 before 30 minutes, and is slightly dropping after 30 minutes. It gives a reason why the power consumption of the compressor is very high in general.

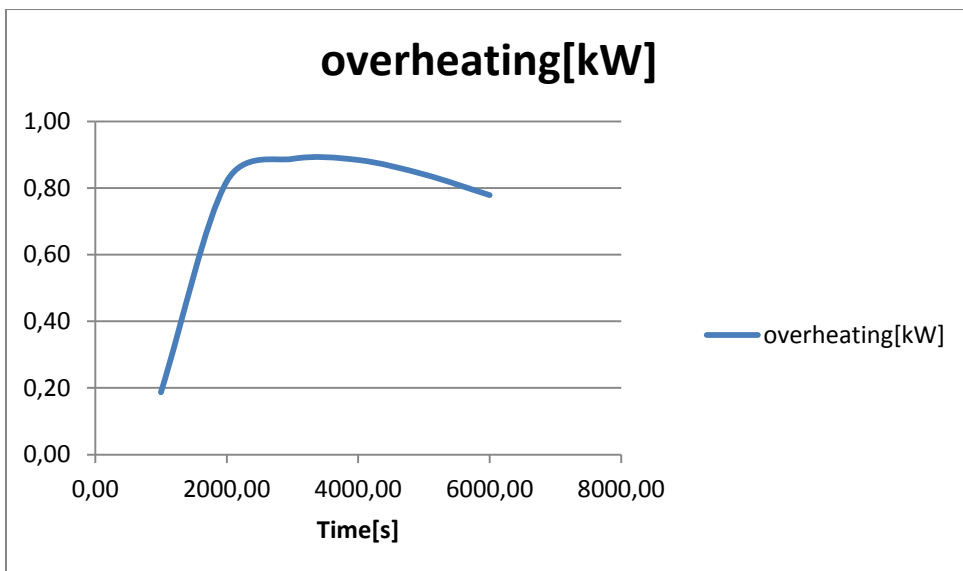

Figure 4. 19

Figure below shows the COP for the heating capacity and cooling capacity. The COP values show the performance of the system. Compared to experiment.1 both the COP (cooling) and COP (heating) is lower.

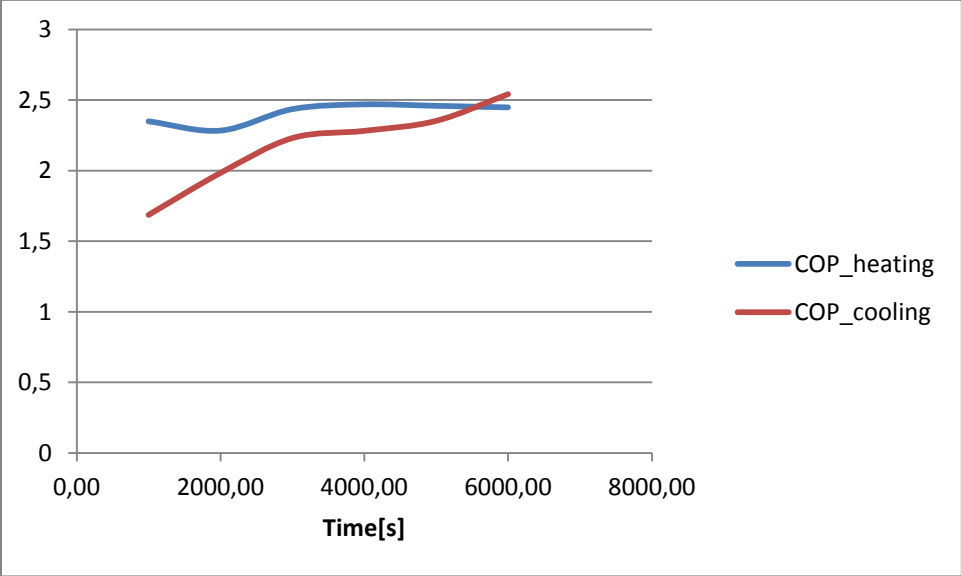

Figure 4. 20

Table below shows some of important summing-up values for this experiment.

Result values	
Water extracted	2,6 kg
Running time	102 minutes
COP_average(cooling)	1,62415
COP_average(heating)	1,796699
Compressor effect	0,957268 kW
Motor effect	0,200055 kW
Total effect	1,157323 kW
Mass flow	1010 kg/min
Total power consumption	1,996 kWh
SMER	1,302605 kg/kWh

Table 4.4

4.3.3 Experiment nr.3

This experiment is carried out with mall external gas cooler connected after 60 minutes (high refrigerant charge). From the experiment nr.1 and nr.2, it can be seen that turning off external gas cooler have a benefit reducing the running time. So this experiment is aimed to see the power consumption and running time reduction.

Figure below shows the pressure at evaporator (PI-1), compressor outlet (PI-2), and external gas cooler outlet (PI-4) over the time. It can be seen that around 53 minutes, the pressure at high pressure side is almost 159 bars, which is already higher than the maximum allowable pressure, the compressor is getting very hot since the lubricant oil can not cool the compressor down, and the high pressure valve is beginning to leak out refrigerant at 53 minutes, the external gas cooler is connected at 57 minutes to protect the compressor since the pressure and temperature is still too high.

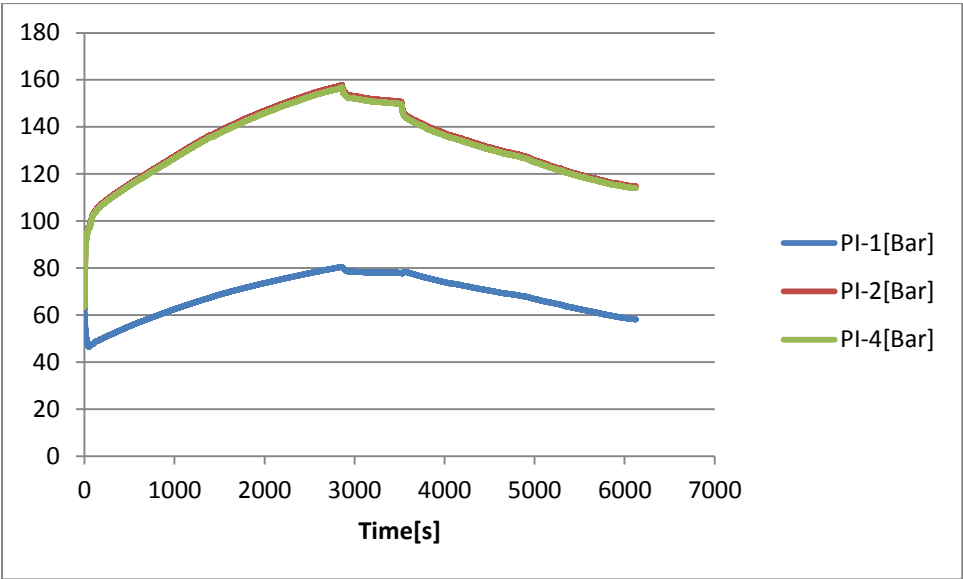

Figure 4. 21

Figure below shows the CO₂ temperatures at evaporator outlet, compressor outlet, external gas cooler inlet and outlet.

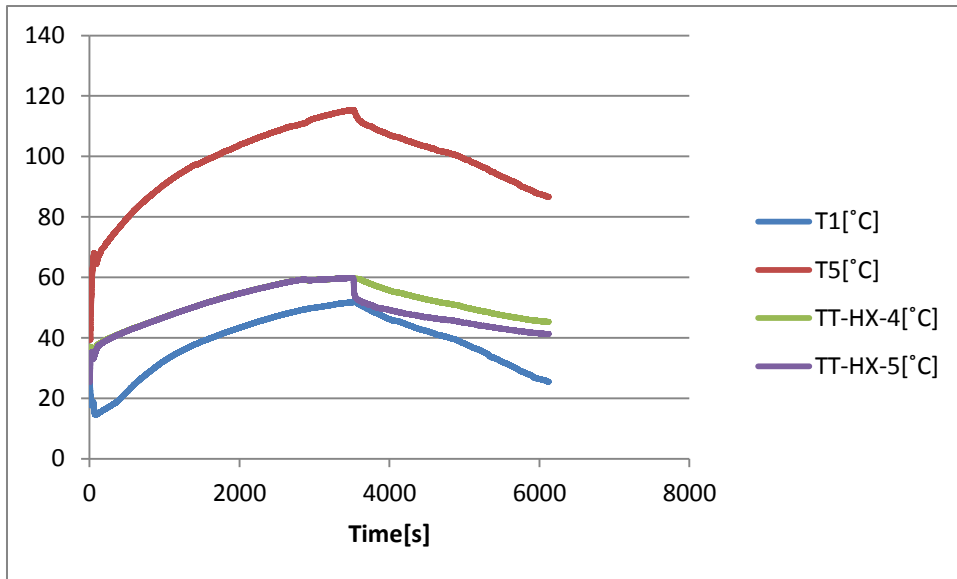

Figure 4. 22

Figure below shows the inlet and outlet relative humidity of the drum over time.

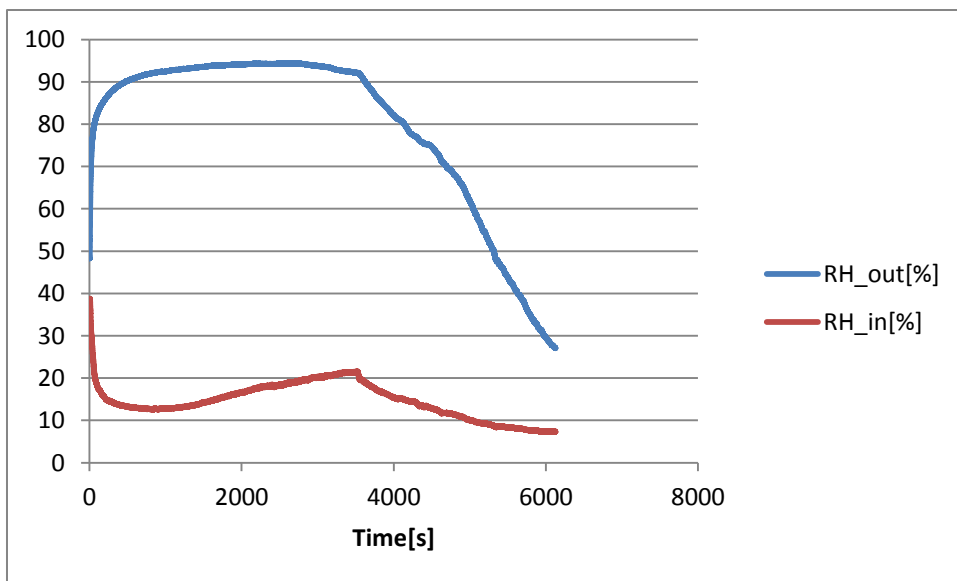

Figure 4. 23

Figure below shows the power consumption of the compressor and the motor used to run the drum. The sensor to measure the power consumption of the compressor has maximum value of 1000Watt, the value above 1000Watt is got from a electronic meter, and the value is filled out manually in the spread sheet, that explains why the curve is not smooth above 1000Watt.

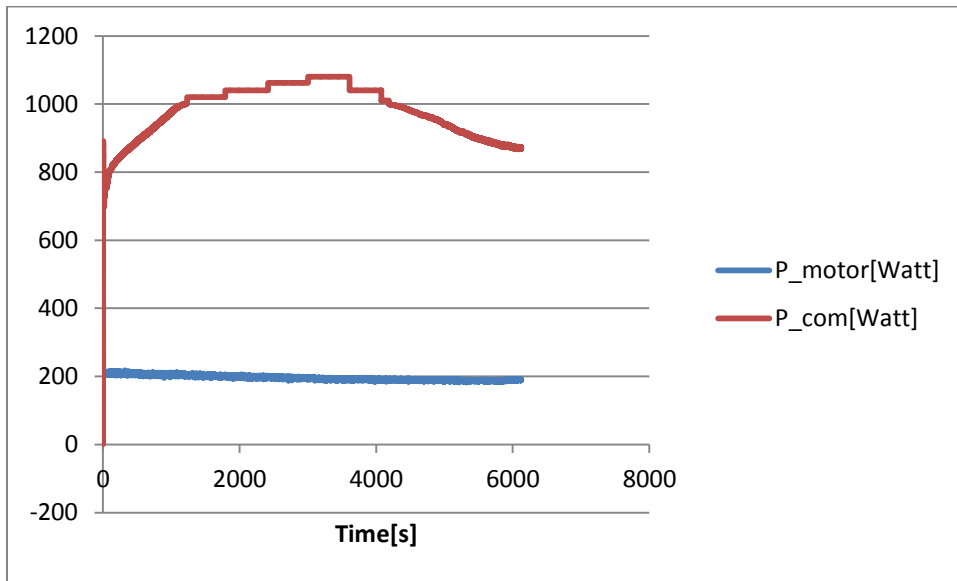

Figure 4. 24

Figure below shows the temperature difference between the inlet and outlet temperature of the air flowing through the external gas cooler. it can be seen that the temperature difference is much bigger than experiment nr.1 and nr.2 after 57 minutes when the external gas cooler is connected, that's because the temperature difference between the ambient air and refrigerant temperature is higher, the temperature difference is getting smaller over time after the temperature level of each component is dropping down.

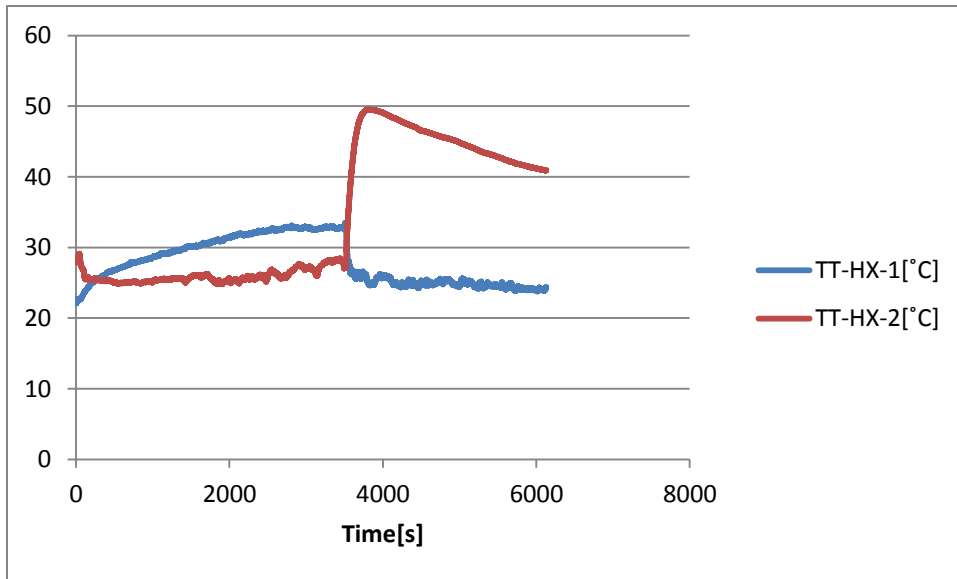

Figure 4. 25

Figure below shows the air temperature before drum, after drum and after flowing through evaporator.

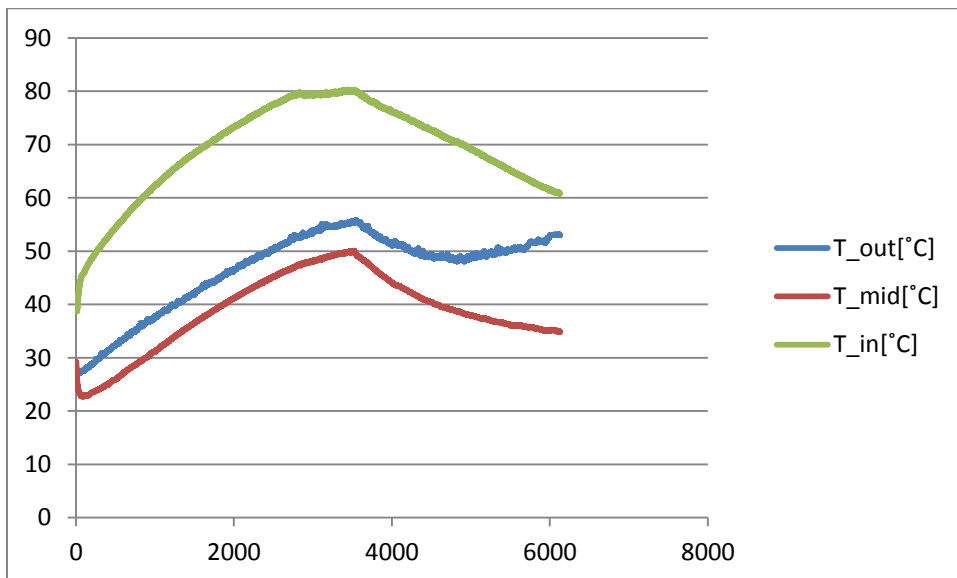

Figure 4. 26

Table below shows some of important summing-up values for this experiment.

Result values	
Water extracted	2,42 kg
Running time	100 minutes
COP_average(cooling)	0,945292
COP_average(heating)	1,812003
Compressor effect	0,980879 kW
Motor effect	0,196111 kW
Total effect	1,17699 kW
Mass flow	1016 kg/min
Total power consumption	2,003 kWh
SMER	1,208188 kg/kWh

Table 4.5

4.3.4 Experiment nr.4

This experiment is carried out with the extra large gas cooler connected with system, and the fan is blowing ambient air through the large gas cooler through the whole experiment. From the experiments nr.1 to nr.3 and some small tests, it is found out that the refrigerant charge is significantly influencing the power consumption of the compressor, a high refrigerant charge will give a high pressure and temperature level, thus a high compressor power consumption, so for this test it is carried out with a reduced refrigerant charge.

From the figure above it can be seen PI-1, PI-2, PI-4 still keep building up, and slows down after 60 minutes and peaks at 89,5 bars (PI-2, discharge pressure) at after around 85 minutes. Compared to experiment nr.1 with a high refrigerant charge, the peaking time is similar, 81 minutes (experiment nr.1) and 85 minutes (experiment nr.1), the latter is 4 minutes later, the peak pressure (89,5 bars) for this experiment is 34.1% less than that in experiment nr.1. The pressure difference between the discharge pressure (PI-2) and the external gas cooler (PI-4) is still low, thus the pressure loss.

PI-1(evaporation pressure) shares the same tendency as PI-2 and PI-2. The peak pressure is around 47.4 bars, while the peak pressure for experiment nr.1 is 61.4 bars

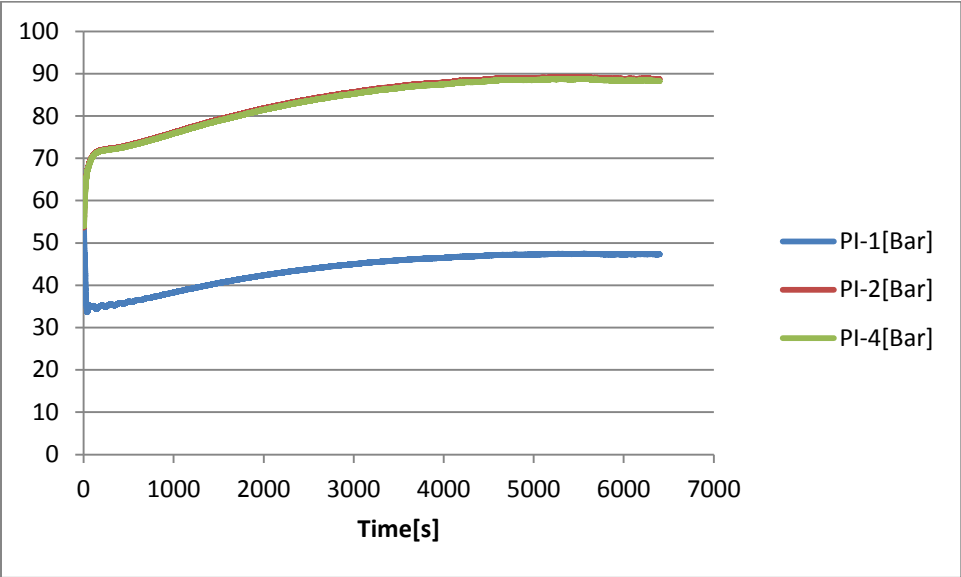

Figure 4. 27

Figure below shows the CO₂ temperatures at evaporator outlet, compressor outlet, external gas cooler inlet and outlet. It shares the same tendency as pressure distribution. The only difference is that the temperature is not dropping, it is relative stable at the end of experiment.

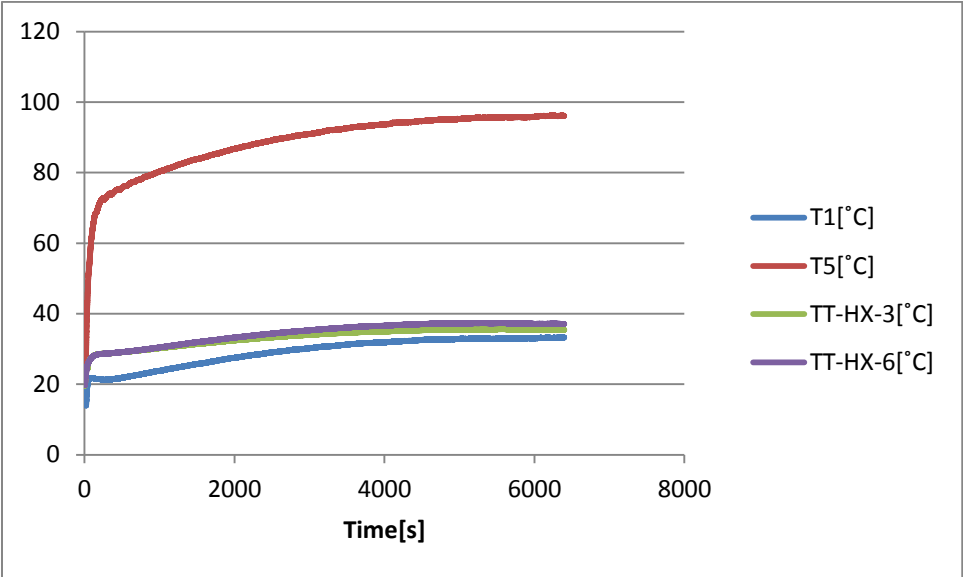

Figure 4. 28

Figure below shows a zoomed diagram for temperature difference between external large gas cooler inlet and outlet. It can be noticed that the temperature difference is rising over time, the reason is that the temperature of main gas cooler outlet (same as external gas cooler inlet) is increasing, which gives a higher temperature difference between the air flow blew by the fan and the CO₂ temperature. At the end the temperature difference is around 1.6 °C, it is not a high temperature difference, which gives a relative low cooling capacity of CO₂. The reason why the temperature difference is almost zero before 20 minutes, it is firstly because of a relative low temperature of CO₂ at external gas cooler inlet, it is also because that the new installed thermal couple has a relative long retardness of reaction time, which results in a measurement error.

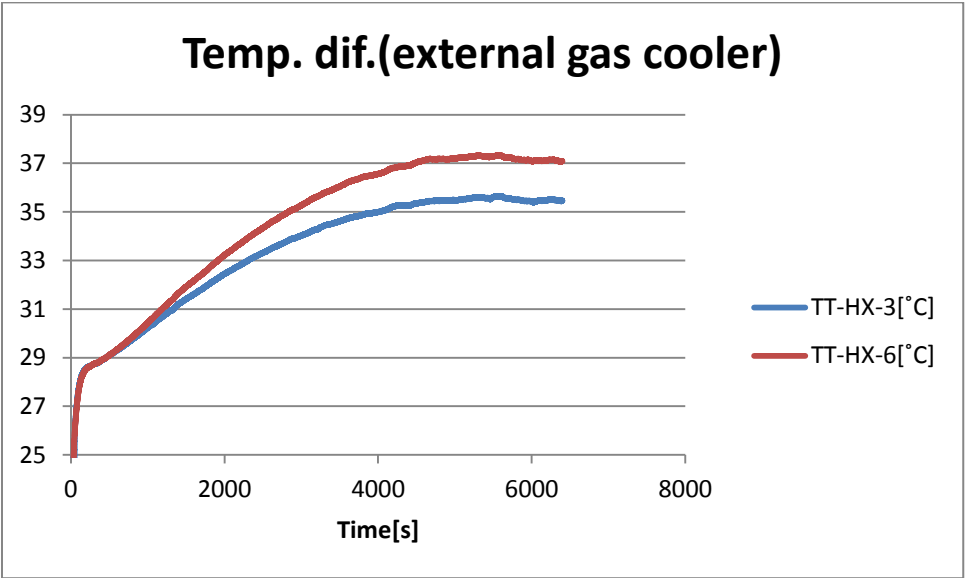

Figure 4. 29

Figure below shows the temperature before drum, after drum and after flowing through evaporator. The inlet temperature T_{in} rises from the room temperature to 54.4°C. Temperature in the drum can be up to 100°C in the modern clothes dryers. So here the maximum temperature (54.4°C) is not considered as high temperature, and will not damage the fabric. The difference between air temperature after drum and air temperature after evaporator is kept relative constant (around 7°C). The difference between outlet temperature of CO₂ and outlet temperature of air after evaporator is around 3°C to 4°C, while temperature of CO₂ at the inlet of evaporator rises from 3.5°C to 11.9°C and the temperature of air at inlet of evaporator rises from 19°C to 39°C, the maximum temperature difference is up to 26.9°C.

Compared to the temperature difference outlet of evaporator, it means that the heat transfer for the evaporator is good.

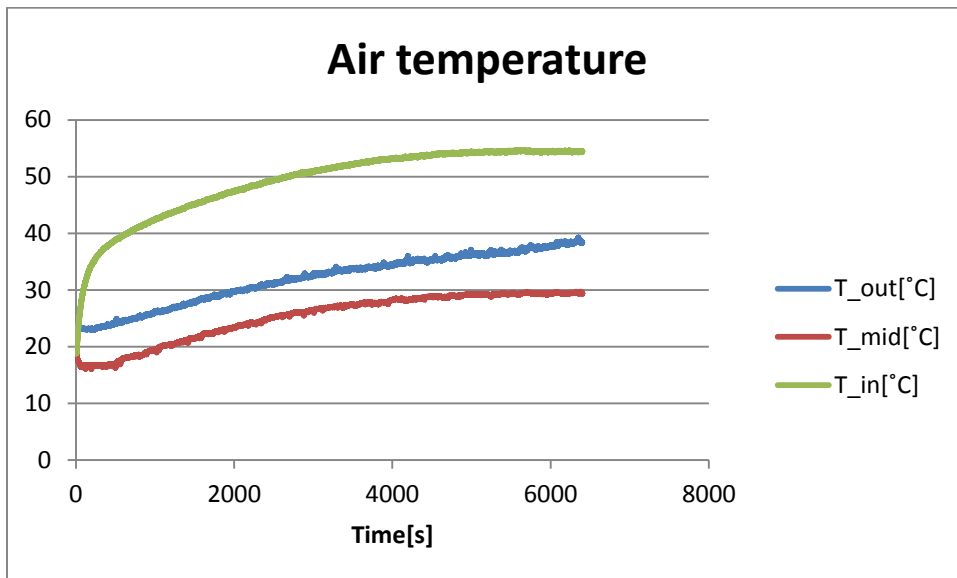

Figure 4. 30

Figure below shows the relative humidity in and out of the drum. The value of the relative humidity RH_out keeps relative constant (around 90%) until after 50 minutes, and it begins to drop at around 65 minutes. Compared to experiment nr.1, in which the relative humidity is around 87%, and begins to drop at around 50 minutes, the experiment will take more time to dry off the fabric because lowered air temperature level at inlet of drum contains has less ability to absorb water than that in experiment nr.1.

This experiment stops at the value of relative humidity around 64%, the fabric was taken out and weight, it was found out the fabric is still humid. There was still 3.7% of water not dried off. According to the information gotten from ASKO, the experiment is still a valid test if the water content is within 4%. It is assumed that another 10 to 15 minutes is needed to dry off the fabric.

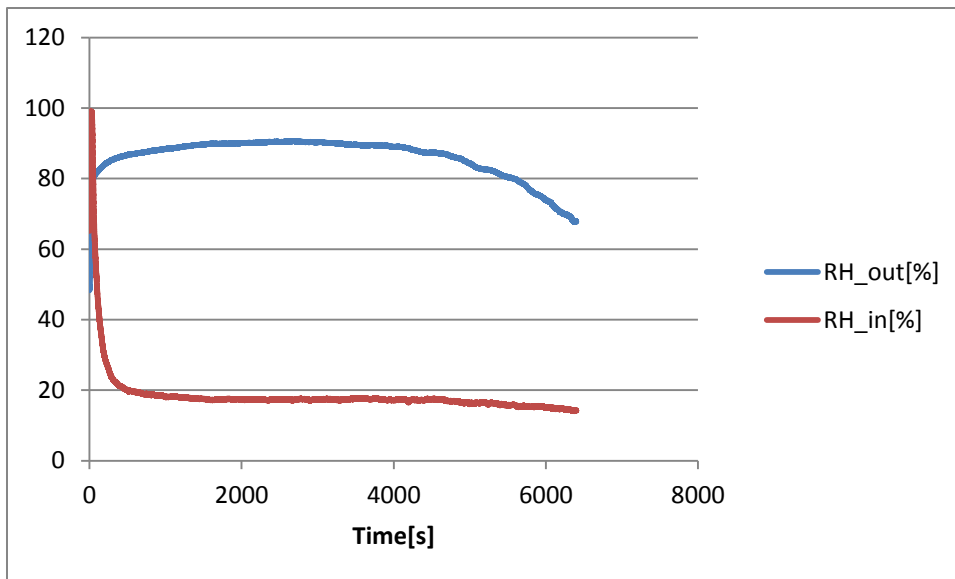

Figure 4. 31

Figure below shows the power consumption of the compressor and the motor used to run the drum. The compressor power consumption peaks at around 669W, compared to experiment nr.1, which peaks at around 923W, it is 38% less. Unlike experiment nr.1 the power consumption for this experiment rises from 570W to 669W, while in experiment nr.1 the power consumption is increased from 600W to 923W, the t of power consumption increasing is much higher than that for this experiment.

PS: The drum power consumption starts 214W and drops to 191W at the end, it could be because the heated drum influences the working condition in a certain level, but since this project is focused on the CO₂ heat pump and the variation of the drum power consumption is not large, so this phenomenon won't be studied.

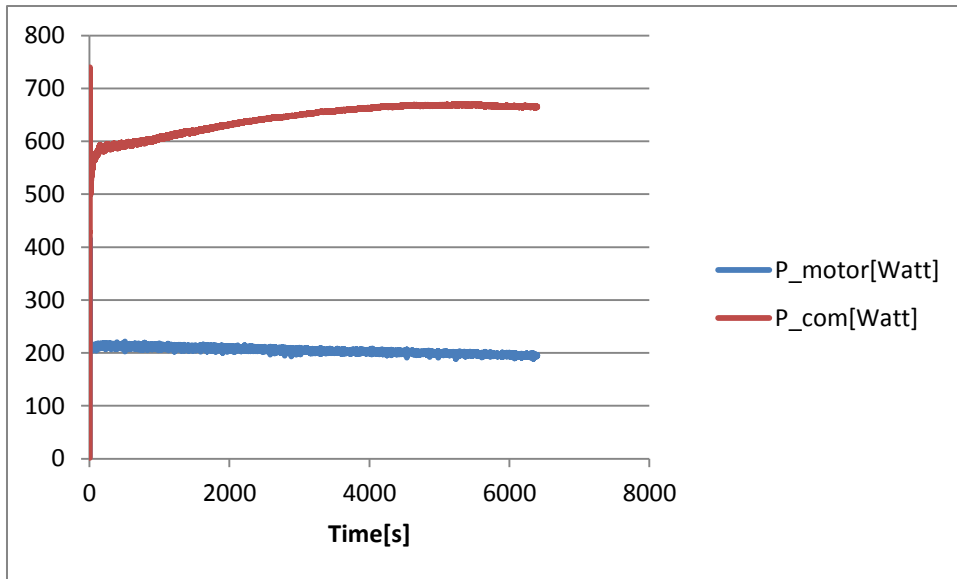

Figure 4. 32

Figure below shows the temperature difference between the inlet and outlet temperature of the air flowing through the external gas cooler. Compared to experiment nr.1 using a small external gas cooler, using the large external gas cooler has give the maximum temperature difference of 24°C, slightly higher than 20°C in experiment nr.1. Since the air capacity is much lower than CO₂ and the volume of a large external gas cooler is around two times bigger than the small one, the temperature difference is only 4°C higher, it is considered that the heat transfer using an large external gas cooler is much better than expected.

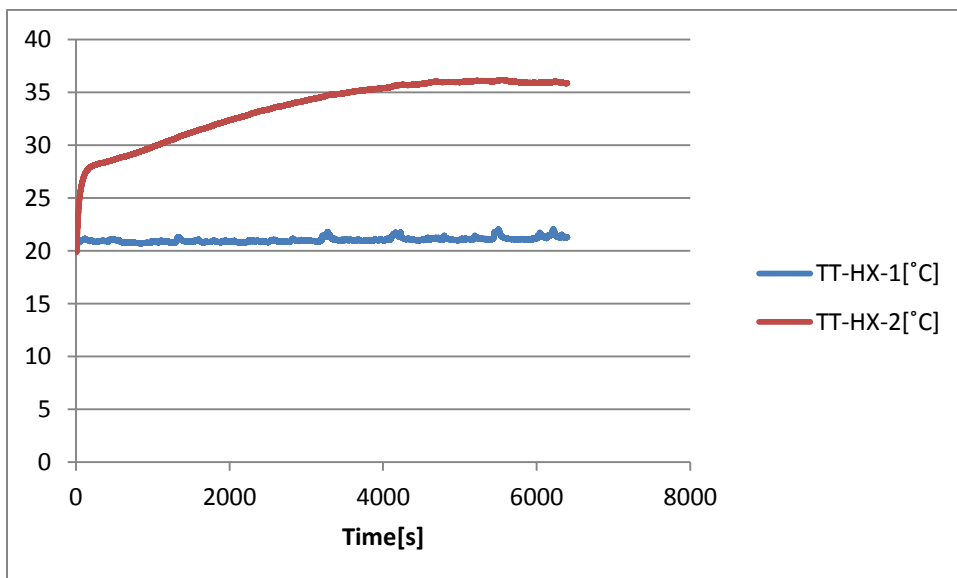

Figure 4. 33

In this project some data is extracted to calculate the performance of the evaporator, main gas cooler, external gas cooler, overheating and the COPs, and some data is extracted to draw p-h diagrams, the principle is to give a performance overview of chosen component and the heat pump system as a whole and the data is extracted when the system is relative stable.

Figure below shows the overheating of CO₂ before going to compressor.

A certain level of overheating is needed, it can help evaporate the remaining liquid of CO₂ so that the liquid form of CO₂ will not flow into the compressor and damage it, but too much overheating will result in a high suction temperature. From thermodynamic, more power is needed to compress gas if the starting temperature is increased. The reason is that high starting temperature will increase friction loss, thus high compressor consumption.

From the figure below it can be noticed that the overheating is quite high, up to a little bit more than 500W, and the suction temperature is from 21°C to 33°C, the saturated temperature with corresponding suction pressure is from around 5°C to 13°C. Too much overheating may cause an unneeded power consumption of compressor in this project.

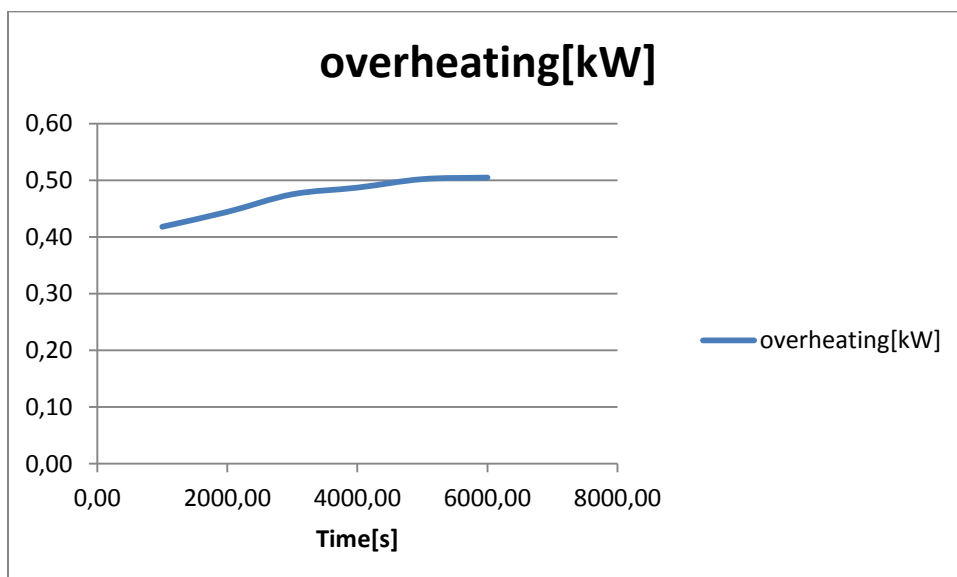

Figure 4. 34

Figure below shows cooling capacity of the evaporator, heating capacity of the main gas cooler and heating capacity of the external gas cooler. There are three heat exchangers in the CO₂ heat pump system, evaporator, main gas cooler, external gas cooler, the performance of each component is shown below.(cooling capacity corresponds to the performance of the evaporator, heating capacity corresponds to the performance of the main gas cooler, heating capacity(external) corresponds to the external gas cooler.)

With a low temperature difference between external gas cooler inlet and outlet, it leads to a very small heating capacity of external gas cooler, while the performance of evaporator and main gas cooler is working quiet fine with relative stable performance.

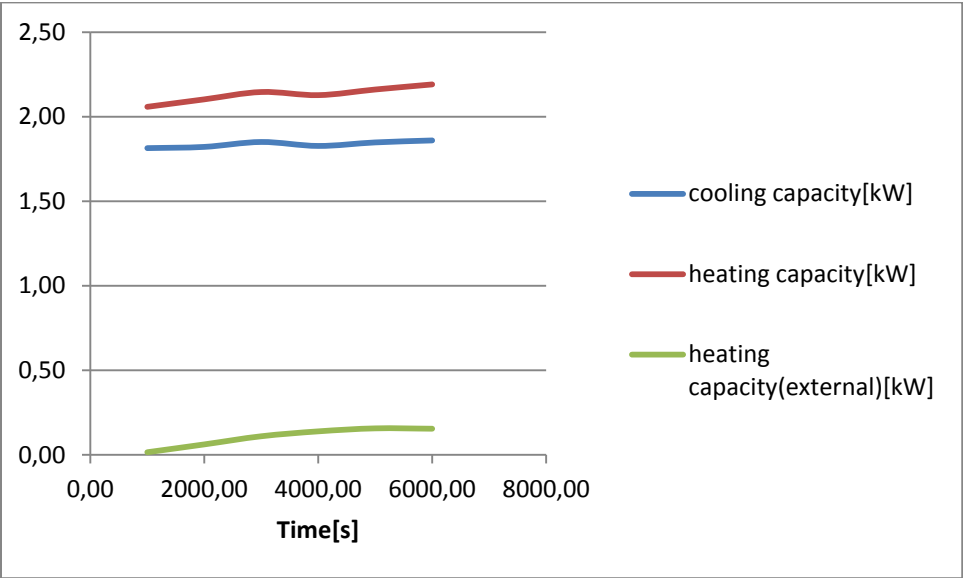

Figure 4. 35

Figure below shows the COP for the heating capacity and cooling capacity. The COP values are dropping over time, it is because when the temperature level and pressure increase over time level at inlet and outlet of compressor, more energy will be consumed and the increasing rate of heating and cooling capacity is not as big as the compressor power consumption.

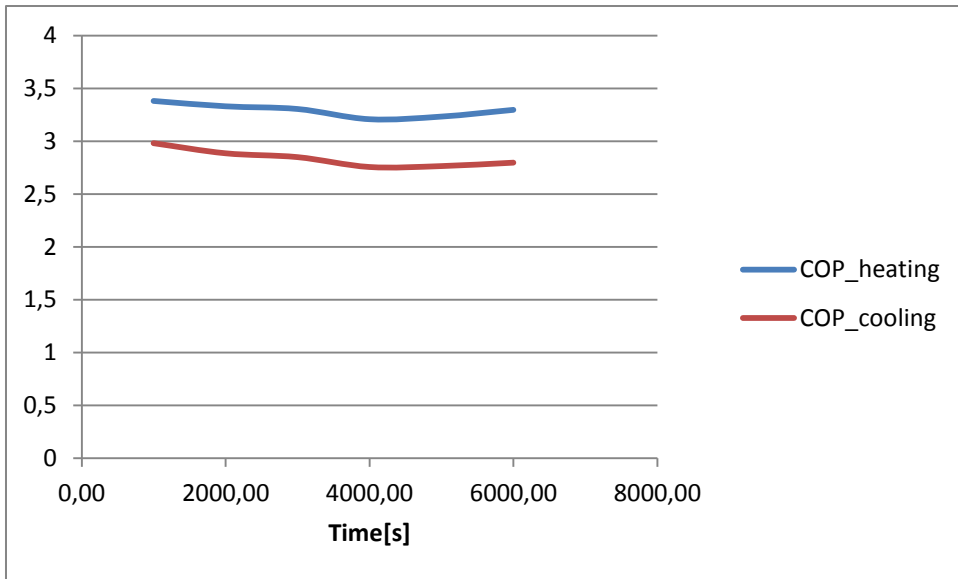

Figure 4. 36

Figure below shows the mass flow over time. Since the experiment is carried out with reduced mass flow, it can be seen that the average mass flow is much lower than that in experiment nr.1

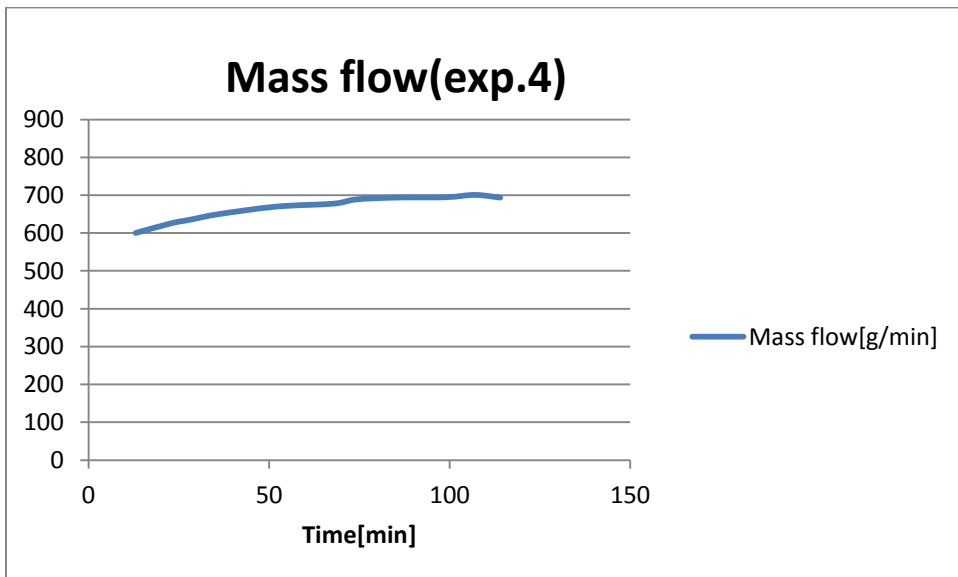

Figure 4. 37

Table below shows some of important summing-up values for this experiment.

Result values	
Water extracted	2,48 kg
Running time	114 minutes
COP_average(cooling)	2,839321
COP_average(heating)	3,292858
Compressor effect	0,642618 kW
Motor effect	0,203579 kW
Total effect	0,846196 kW
Mass flow	666,5455 kg/min
Total power consumption	1,611 kWh
SMER	1,539417 kg/kWh

Table 4.6

4.3.5 Experiment nr.5

This experiment is carried out with large external gas cooler connected after 30 minutes (reduced refrigerant charge). This experiment is similar to experiment nr.2, but with reduced refrigerant charge.

Figure below shows the pressure at evaporator (PI-1), compressor outlet (PI-2) and external gas cooler outlet (PI-4) over the time. It can be seen that unlike experiment nr.2, at which the maximum pressure has boost up to 140 bars and the compressor is considered to be in an abnormal working condition, the maximum pressure is 100 bars for this project.

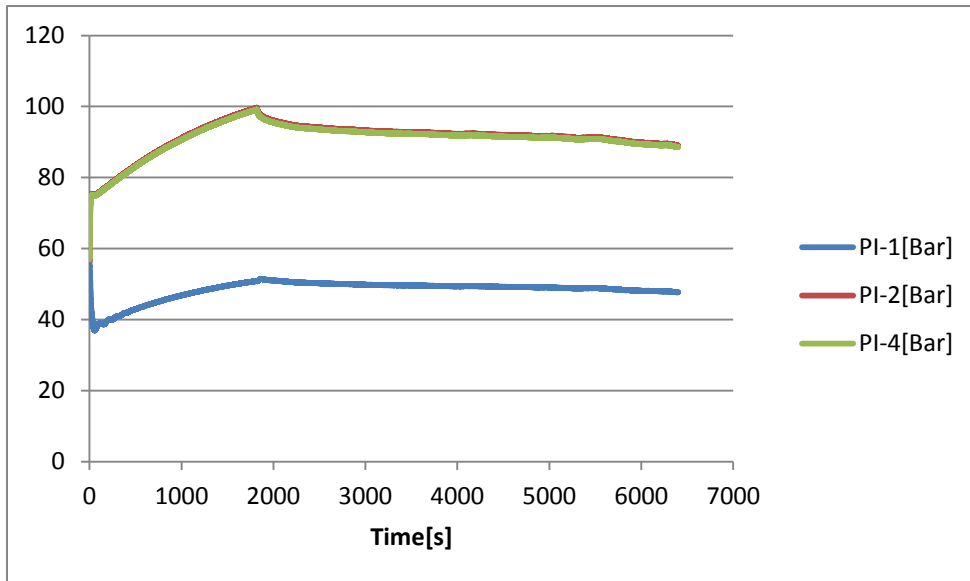

Figure 4. 38

Figure below shows the power consumption of the compressor and the motor used to run the drum. Compared to the maximum compressor power consumption at experiment nr.2, which is around 1000Watt, the maximum compressor power consumption for this experiment is only 735Watt, which is 0.36% less.

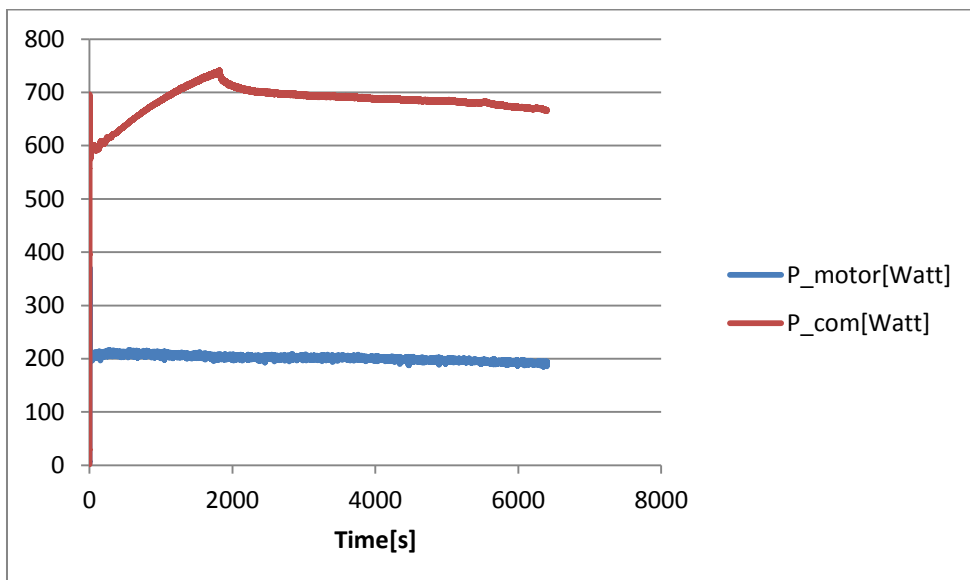

Figure 4. 39

Figure below shows the CO₂ temperatures at evaporator outlet, compressor outlet, external gas cooler inlet and outlet.

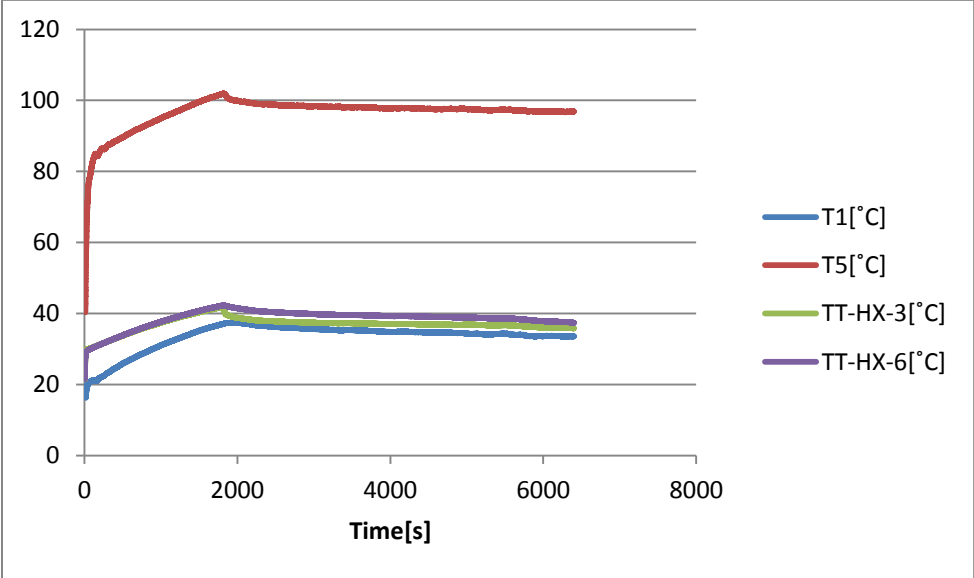

Figure 4. 40

Figure below shows the zoomed diagram for CO₂ temperature difference between inlet and outlet of the external gas cooler. Less than 2.4°C temperature difference makes no much different than experiment nr.1-4.

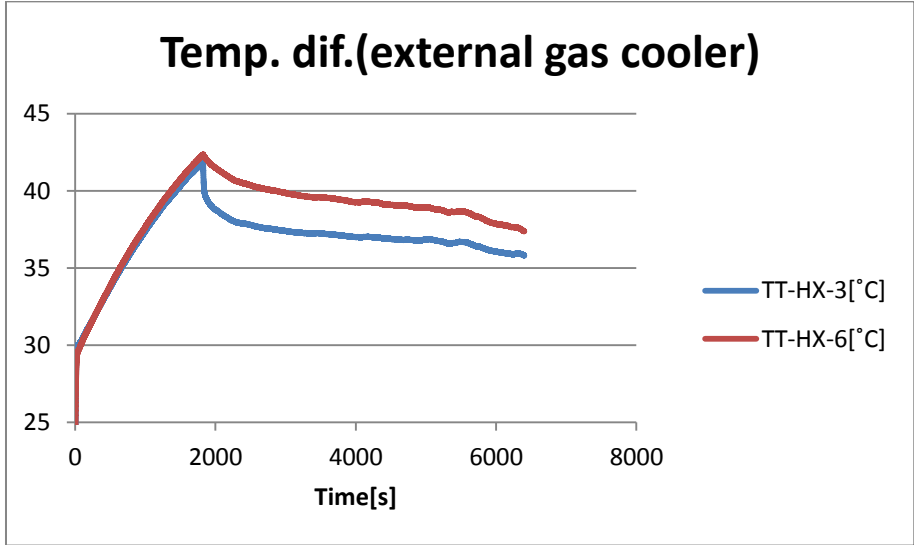

Figure 4. 41

Figure below shows the inlet and outlet relative humidity of the drum over time.

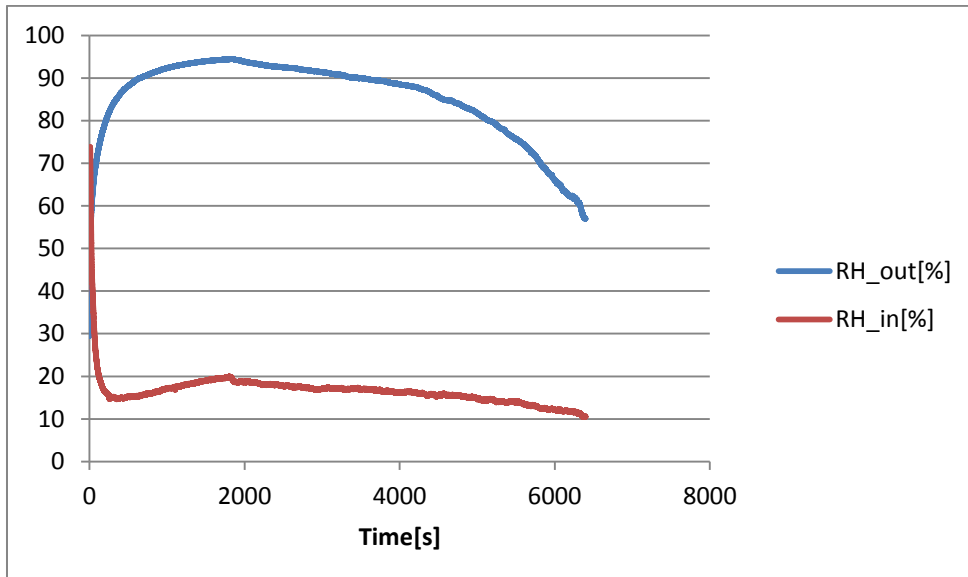

Figure 4. 42

Figure below shows the air temperature before drum, after drum and after flowing through evaporator.

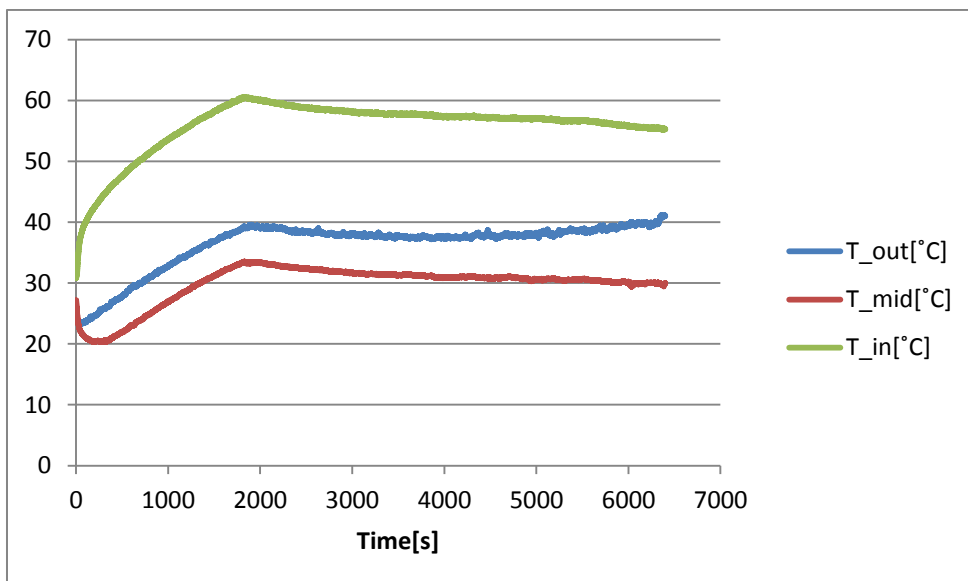

Figure 4. 43

Figure below shows the temperature difference between the inlet and outlet temperature of the air flowing through the external gas cooler.

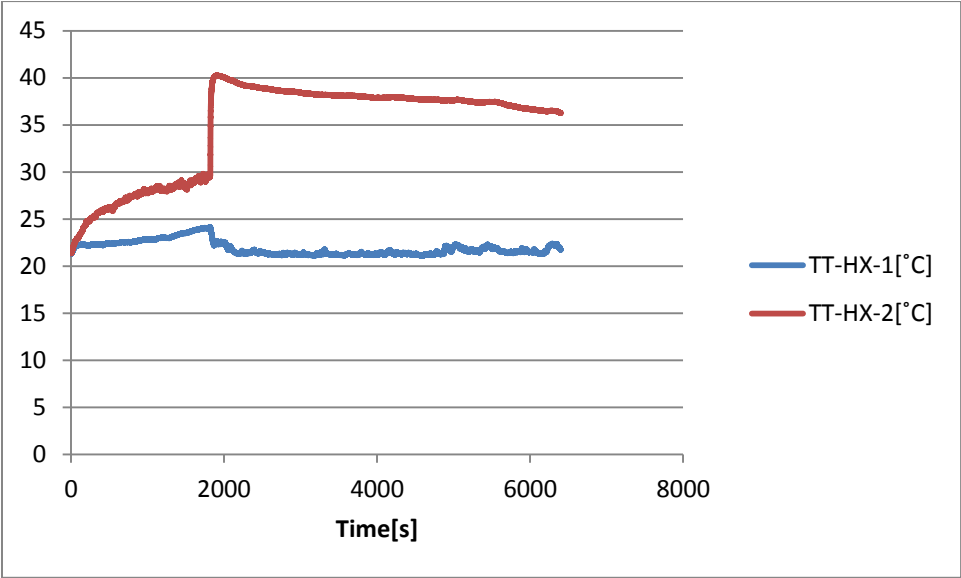

Figure 4. 44

In this project some data is extracted to calculate the performance of the evaporator, main gas cooler, external gas cooler, overheating and the COPs, and some data is extracted to draw p-h diagrams, the principle is to give a performance overview of chosen component and the heat pump system as a whole and the data is extracted when the system is relative stable.

Figure below shows cooling capacity of the evaporator, heating capacity of the main gas cooler and heating capacity of the external gas cooler. Both the cooling capacity and heating capacity is lower than that for experiment nr.2. And the heating capacity is higher than experiment nr.4. And the heating capacity is slightly higher than experiment nr.4 because the temperature level at high pressure side is higher.

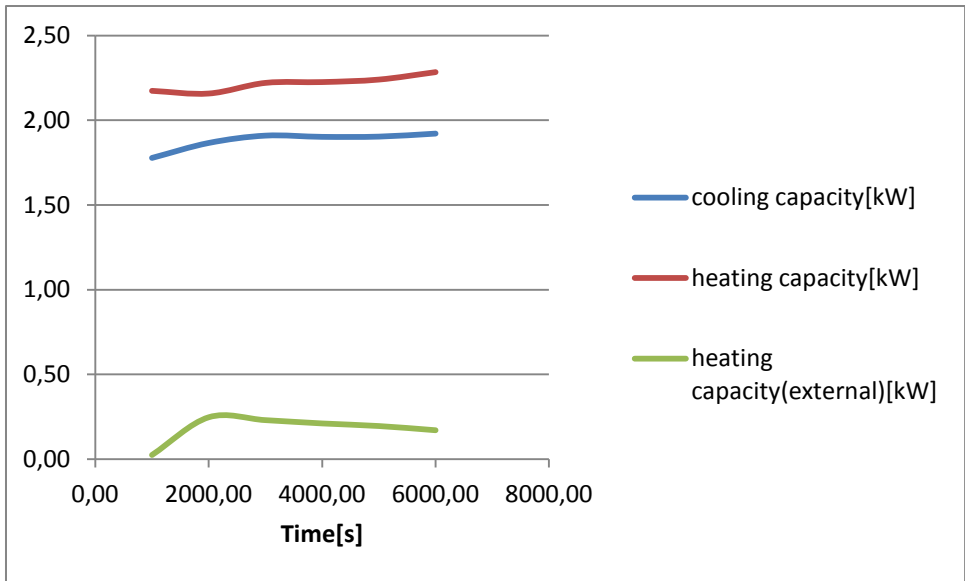

Figure 4. 45

Figure below shows the overheating before compression. The heating capacity keeps increasing until after 30 minutes, and then begins to drop, the range is around from 0.53 to 0.584kw.

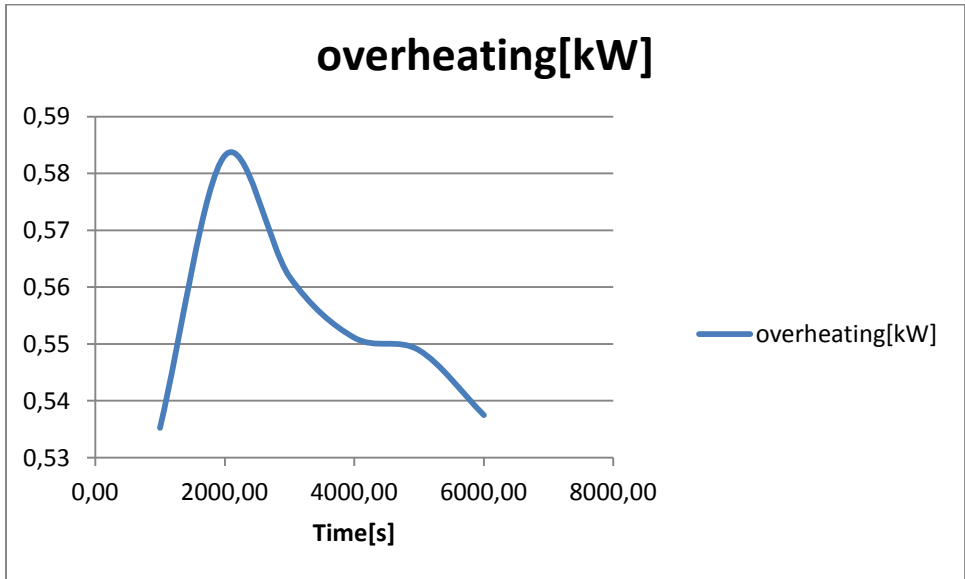

Figure 4. 46

Figure below shows the COP for the heating capacity and cooling capacity. The COPs are much better than experiment nr.1-3, and slightly worse than experiment nr.4 on average.

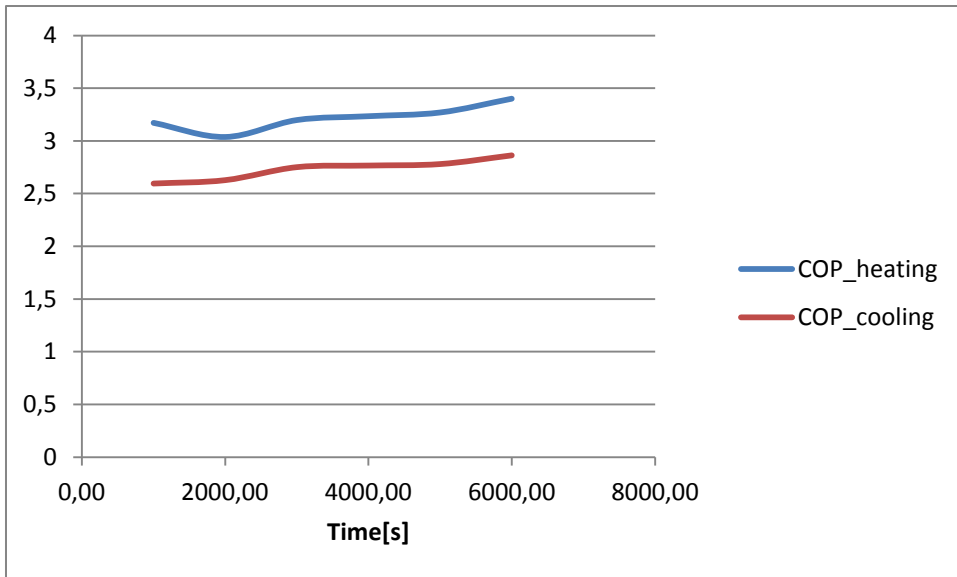

Figure 4. 47

Figure below shows the mass flow over time. The mass flow is higher than that for experiment nr.4 because the temperature level is higher, and then drops a little to around 720g/min, which is similar to experiment nr.4

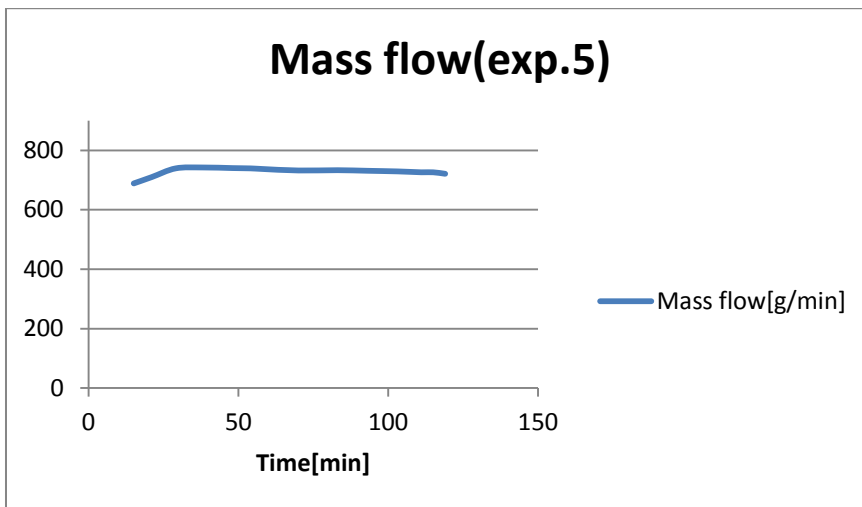

Figure 4. 48

Table below shows some of important summing-up values for this experiment.

Result values	
Water extracted	2,47 kg
Running time	119 minutes
COP_average(cooling)	2,729849
COP_average(heating)	3,218536
Compressor effect	0,680961 kW
Motor effect	0,200156 kW
Total effect	0,881117 kW
Mass flow	728,1429 kg/min
Total power consumption	1,746 kWh
SMER	1,414662 kg/kWh

Table 4.7

4.3.6 Experiment nr.6

This experiment is carried out with large external gas cooler connected after 60 minutes (reduced refrigerant charge). Because the performance of the system is similar between experiment nr.4 and nr.5 (experiment nr.4 is better), more time without connecting external gas cooler may be needed.

Figure below shows the pressure at evaporator (PI-1), compressor outlet (PI-2), external gas cooler outlet (PI-4) over the time. Compared to experiment nr.3 the maximum pressure value is much lower, so unlike experiment nr.3 the compressor is working in normal condition.

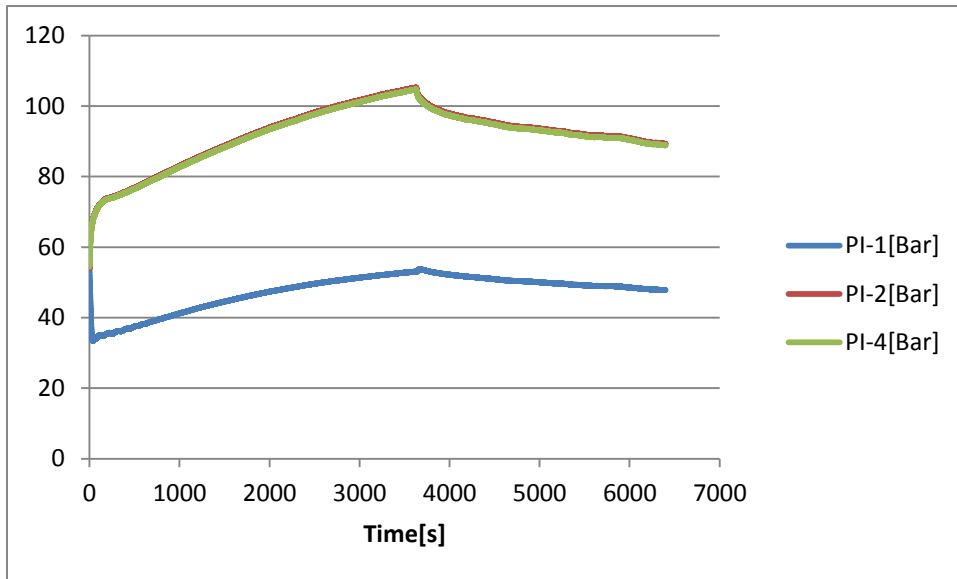

Figure 4. 49

Figure below shows the CO₂ temperatures at evaporator outlet, compressor outlet, external gas cooler inlet and outlet.

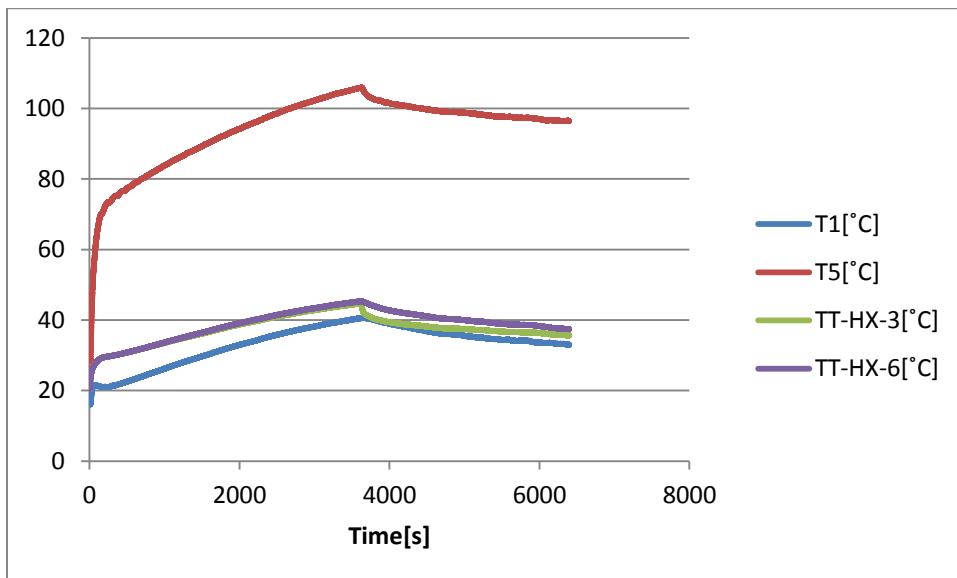

Figure 4. 50

Figure below shows the inlet and outlet relative humidity of the drum over time.

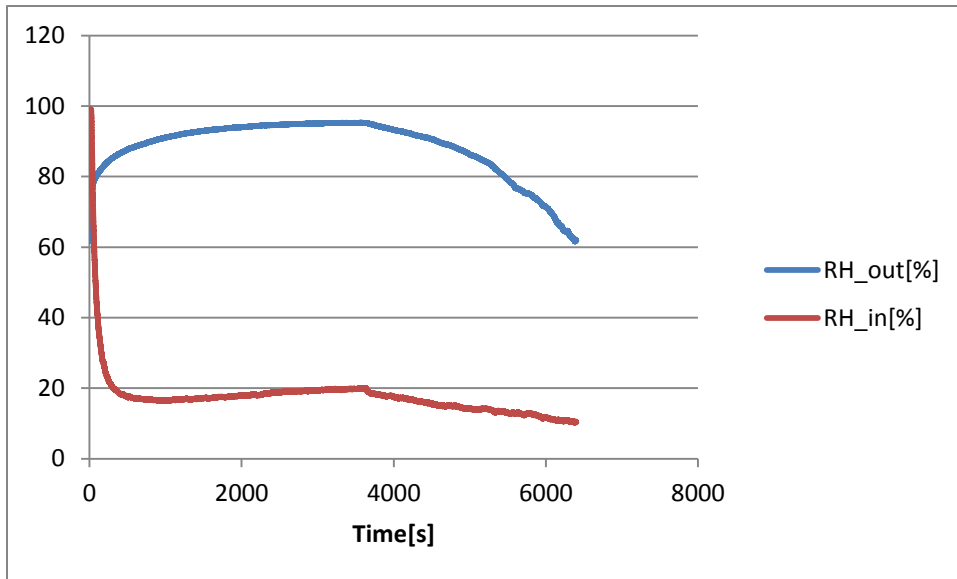

Figure 4. 51

Figure below shows the power consumption of the compressor and the motor used to run the drum. This diagram is very similar to experiment nr.5, except that the pressure is keeping increasing to a maximum power consumption of 778 Watt until 60 minutes. Another difference is that the when the power consumption is dropping after 60 minutes, it is dropping faster than experiment nr.5. It indicates that there exist equilibrium with a give condition, when relative far away from the equilibrium, it tends to go faster towards the equilibrium.

78

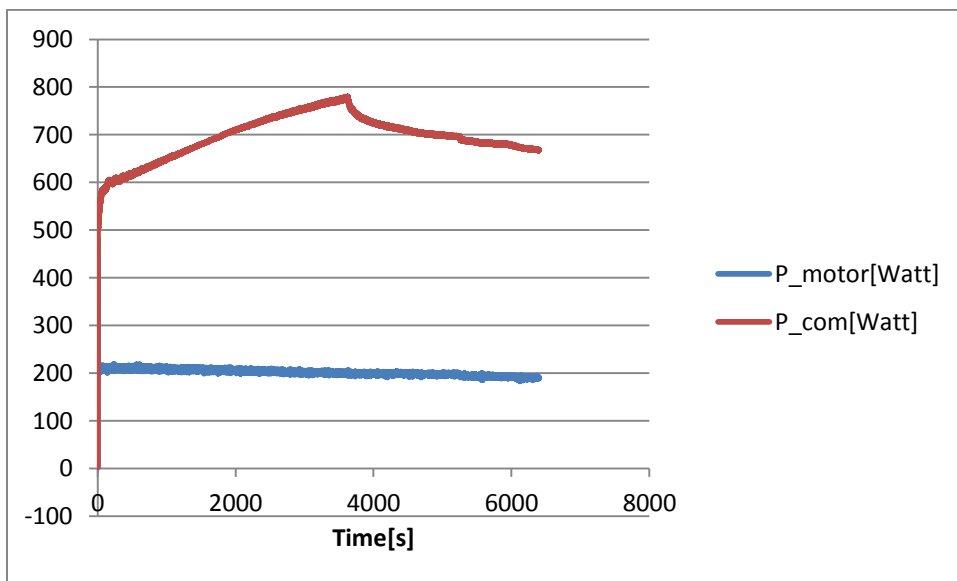

Figure 4. 52

Figure below shows the zoomed diagram for CO₂ temperature difference between inlet and outlet of the external gas cooler. The temperature difference drops from around 3°C to 2°C, which is similar to other experiment with gas cooler not connected in a period.

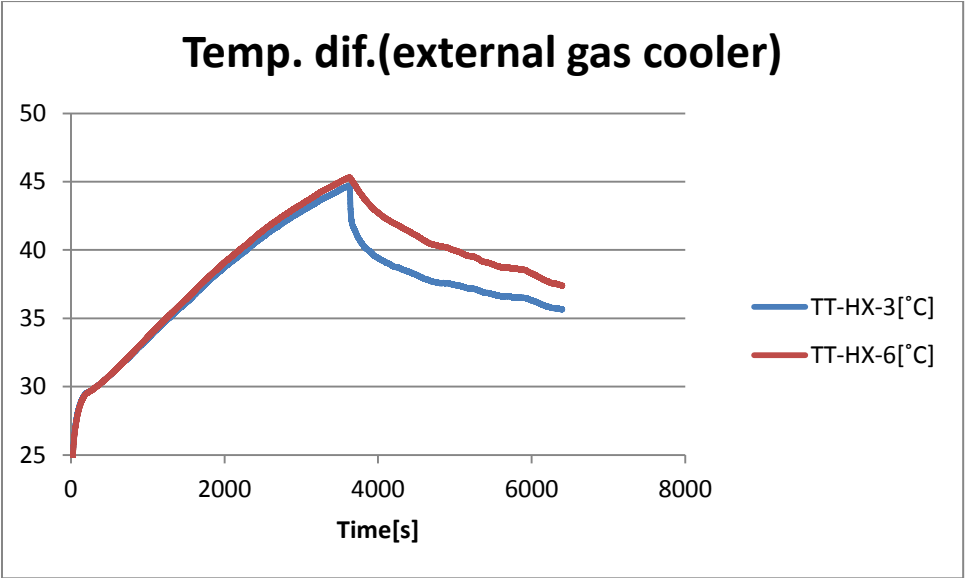

Figure 4. 53

Figure below shows the air temperature before drum, after drum and after flowing through evaporator.

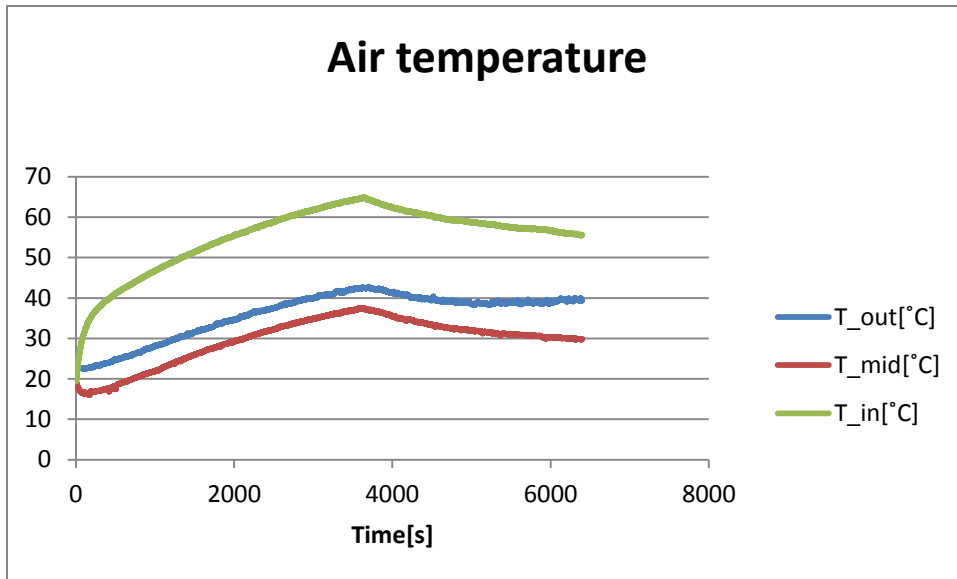

Figure 4. 54

Figure below shows the temperature difference between the inlet and outlet temperature of the air flowing through the external gas cooler.

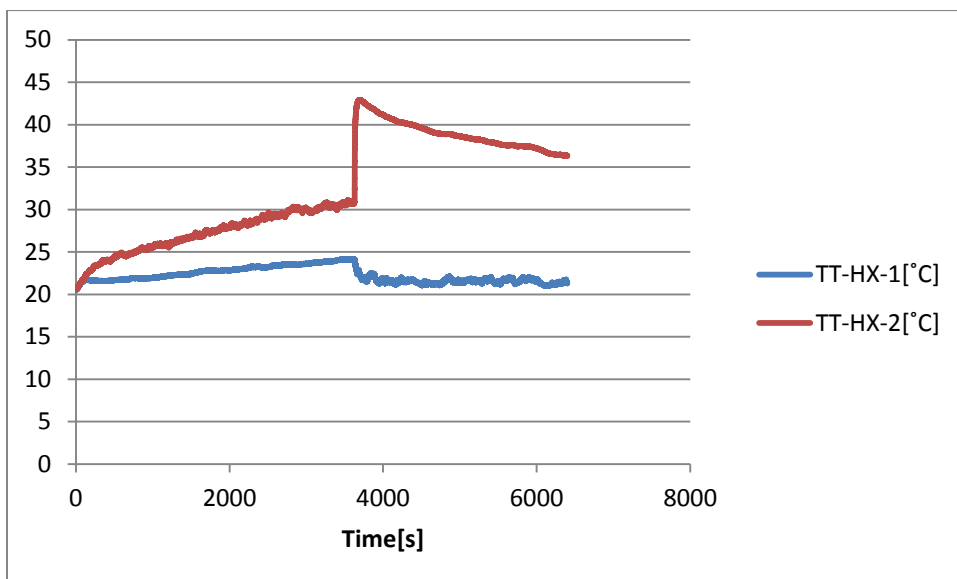

Figure 4. 55

In this project some data is extracted to calculate the performance of the evaporator, main gas cooler, external gas cooler, overheating and the COPs, and some data is extracted to draw p-h diagrams, the principle is to give a performance overview of chosen component and the heat pump system as a whole and the data is extracted when the system is relative stable.

Figure below shows cooling capacity of the evaporator, heating capacity of the main gas cooler and heating capacity of the external gas cooler.

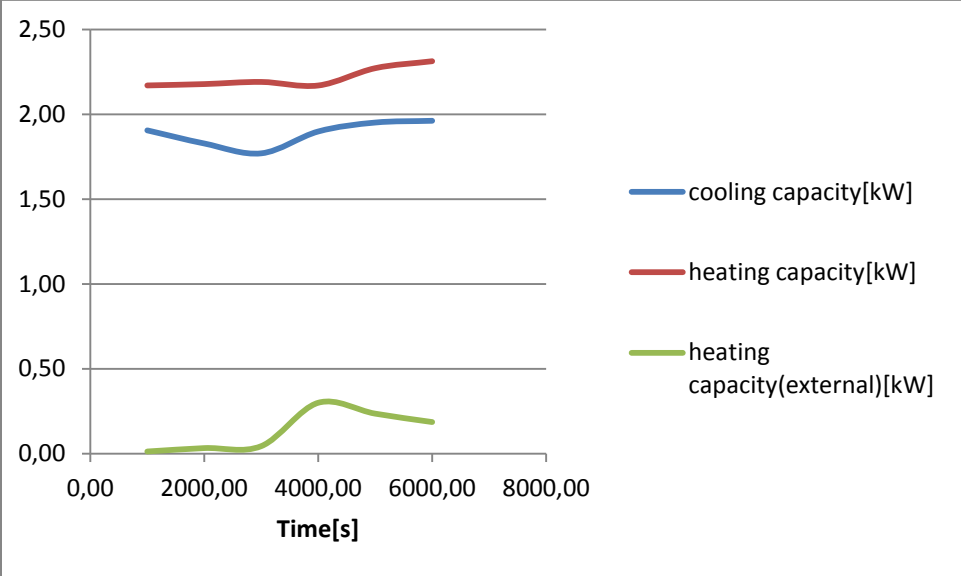

Figure 4. 56

Figure below shows the overheating before compression.

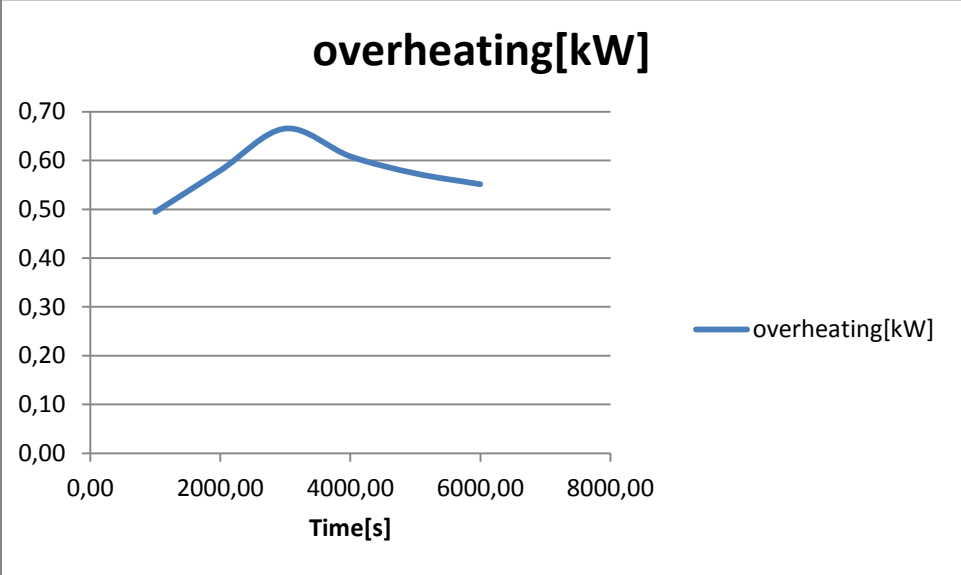

Figure 4. 57

Figure below shows the COP for the heating capacity and cooling capacity.

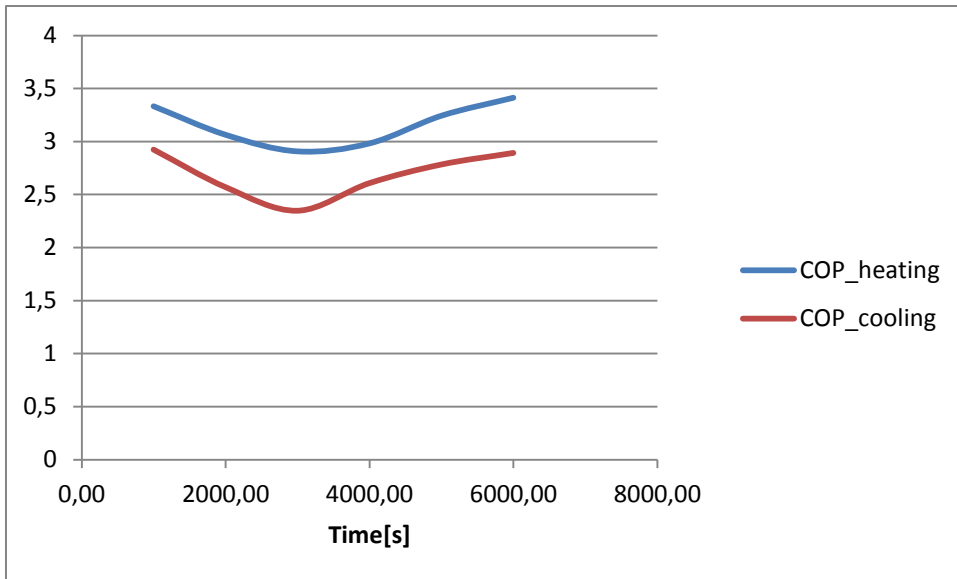

Figure 4. 58

Figure below shows the mass flow over time.

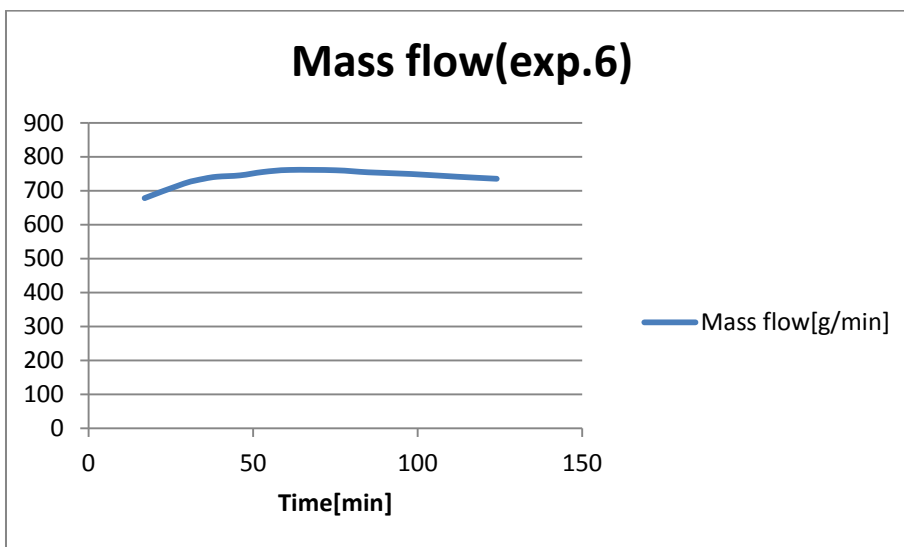

Figure 4. 59

Table below shows some of important summing-up values for this experiment.

Result values	
Water extracted	2,4 kg
Running time	124 minutes
COP_average(cooling)	2,688723
COP_average(heating)	3,158314
Compressor effect	0,68948 kW
Motor effect	0,199902 kW
Total effect	0,889382 kW
Mass flow	739,5833 kg/min
Total power consumption	1,844 kWh
SMER	1,301518 kg/kWh

Table 4.8

4.3.7 Experiment nr.7

This experiment is carried out with small external gas cooler connected during the whole test (reduced refrigerant charge). And another change was made: in the beginning some parts of the heat pump components was exposed to the ambient air, and heat and air leakage was expected to happen, so a plate was installed to cover one side of the machine so that the heat and air leakage might be reduced.

Figure below shows the pressure at evaporator (PI-1), compressor outlet (PI-2), external gas cooler outlet (PI-4) over the time. The high pressure at main gas cooler is rising up to 98 bars and compared to experiment nr.4, he high pressure at main gas cooler is only rising up to 89 bars.

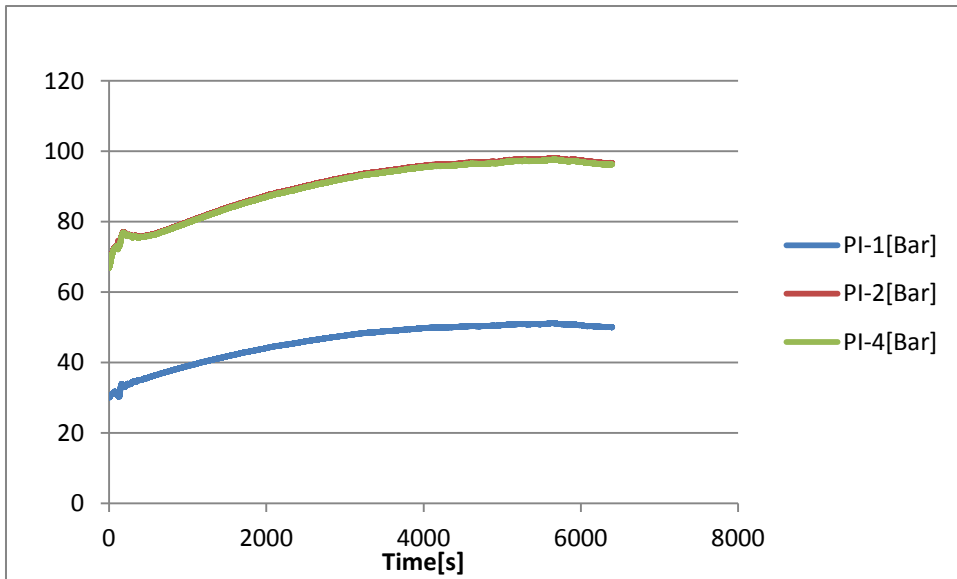

Figure 4. 60

Figure below shows the CO₂ temperatures at evaporator outlet, compressor outlet, external gas cooler inlet and outlet.

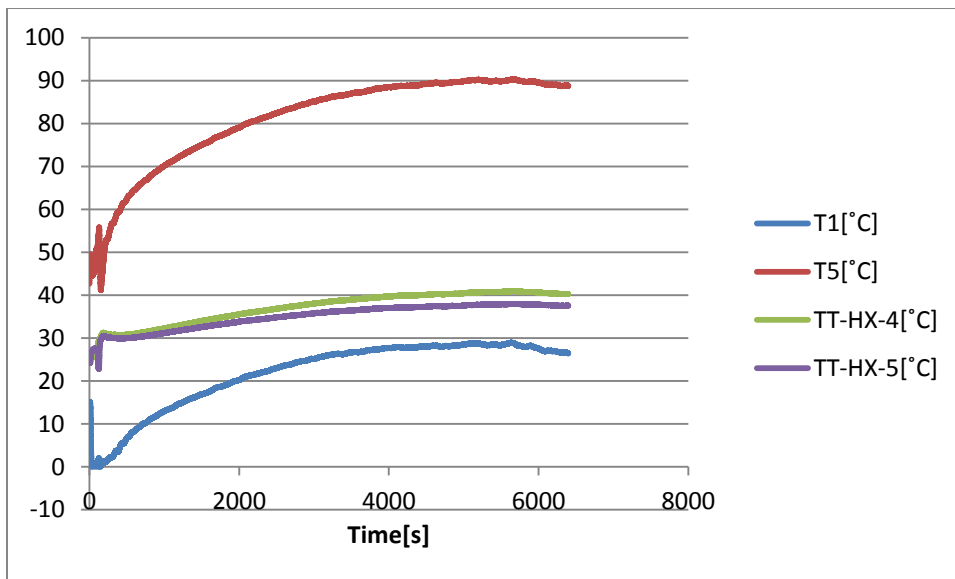

Figure 4. 61

Figure below shows the zoomed diagram for CO₂ temperature difference between inlet and outlet of the external gas cooler. Compared to experiment nr.4, the temperature difference is not

big difference, which means connecting a small gas cooler in this experiment didn't result in expected reduced cooling.

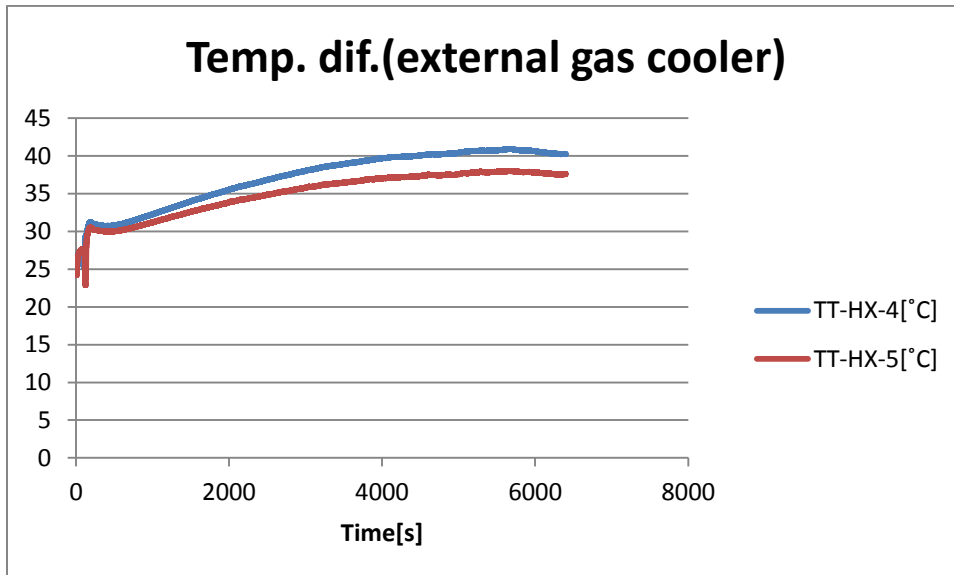

Figure 4. 62

Figure below shows the power consumption of the compressor and the motor used to run the drum. The compressor effect is around 90 Watt larger than experiment nr.4 on average and at the same time the temperature difference between inlet and outlet of external gas cooler is no big difference, which means the size of the external gas cooler may not take all the credit for the rising compressor power consumption. From the former experiments, it is concluded that too much overheating is a problem for increasing the compressor power consumption. when a new plate was installed to prevent the heat leakage, it also somehow reduces the “cooling effect”, it can be felt that the ambient air temperature inside the plate is rising when the experiment is running, and before the plate was installed, the ambient temperature stays at room temperature. This phenomenon is considered as one reason to the increasing power consumption.

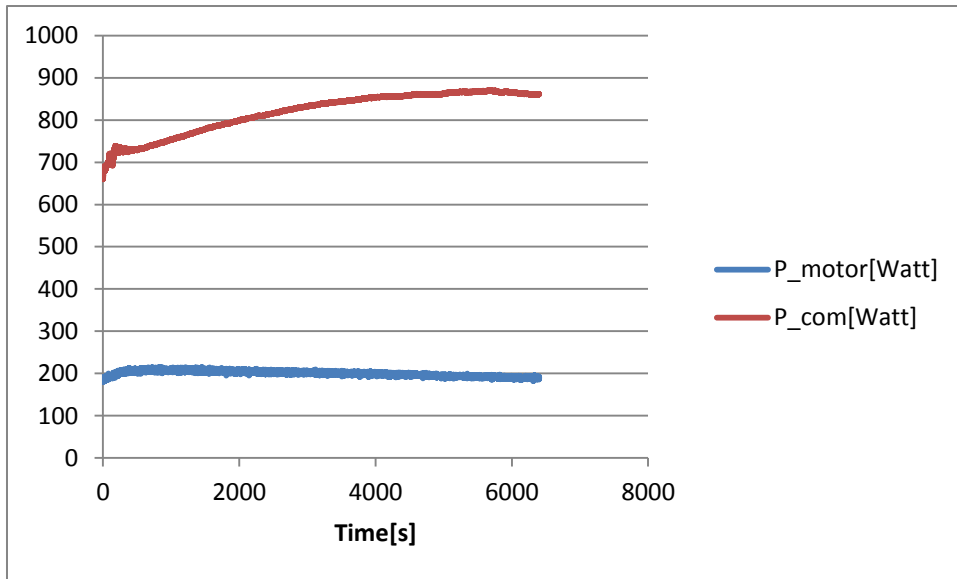

Figure 4. 63

Figure below shows the inlet and outlet relative humidity of the drum over time.

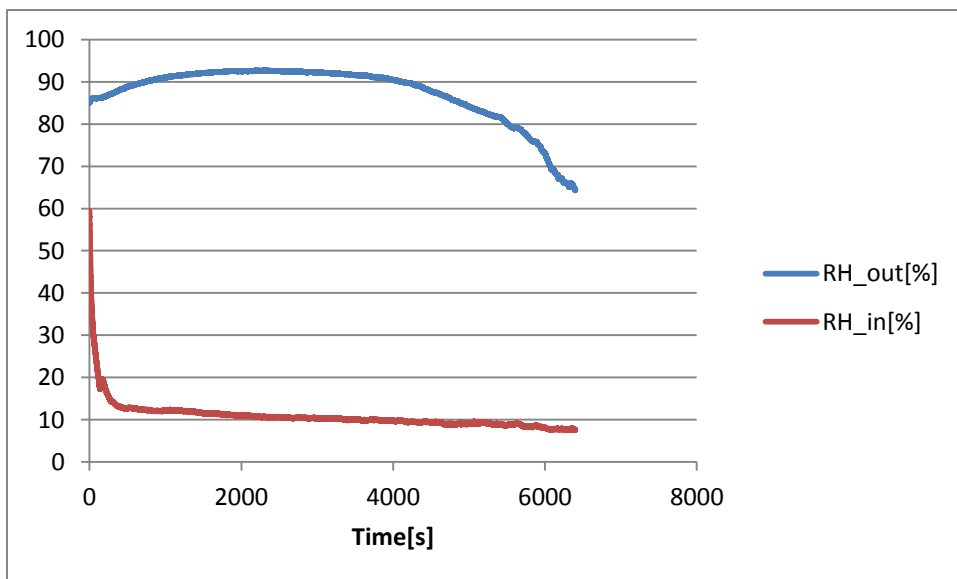

Figure 4. 64

Figure below shows the air temperature before drum, after drum and after flowing through evaporator.

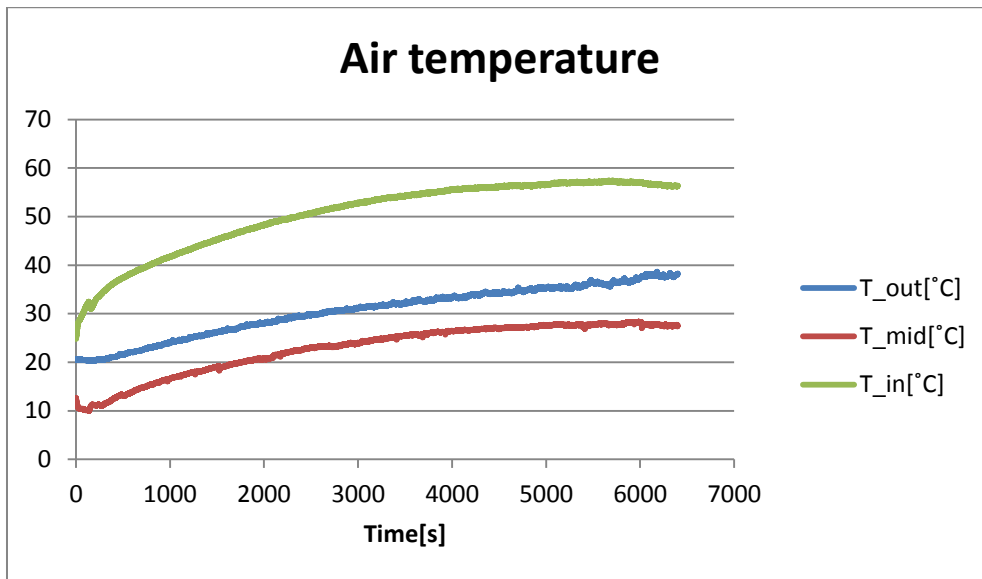

Figure 4. 65

Figure below shows the temperature difference between the inlet and outlet temperature of the air flowing through the external gas cooler.

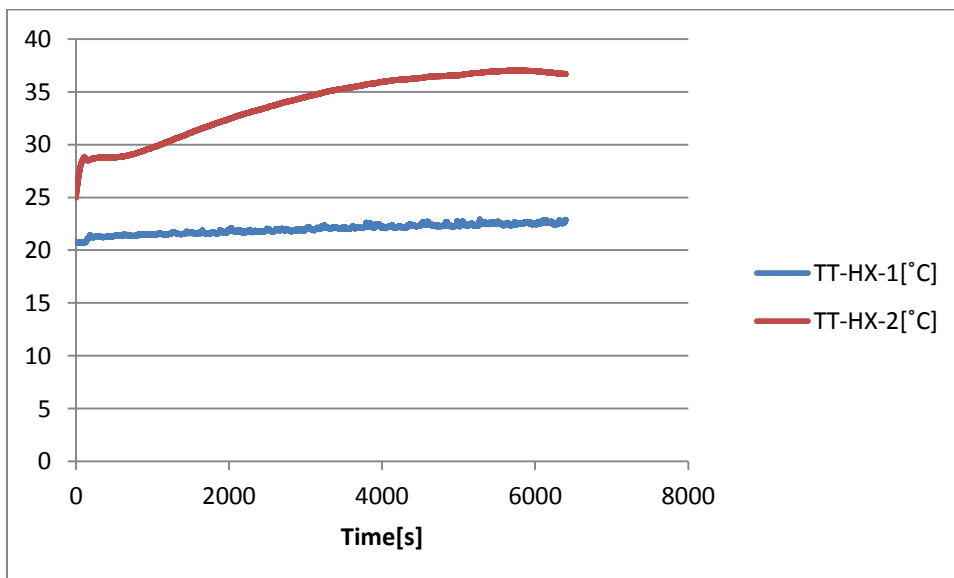

Figure 4. 66

In this project some data is extracted to calculate the performance of the evaporator, main gas cooler, external gas cooler, overheating and the COPs, and some data is extracted to draw p-h

diagrams, the principle is to give a performance overview of chosen component and the heat pump system as a whole and the data is extracted when the system is relative stable.

Figure below shows cooling capacity of the evaporator, heating capacity of the main gas cooler and heating capacity of the external gas cooler.

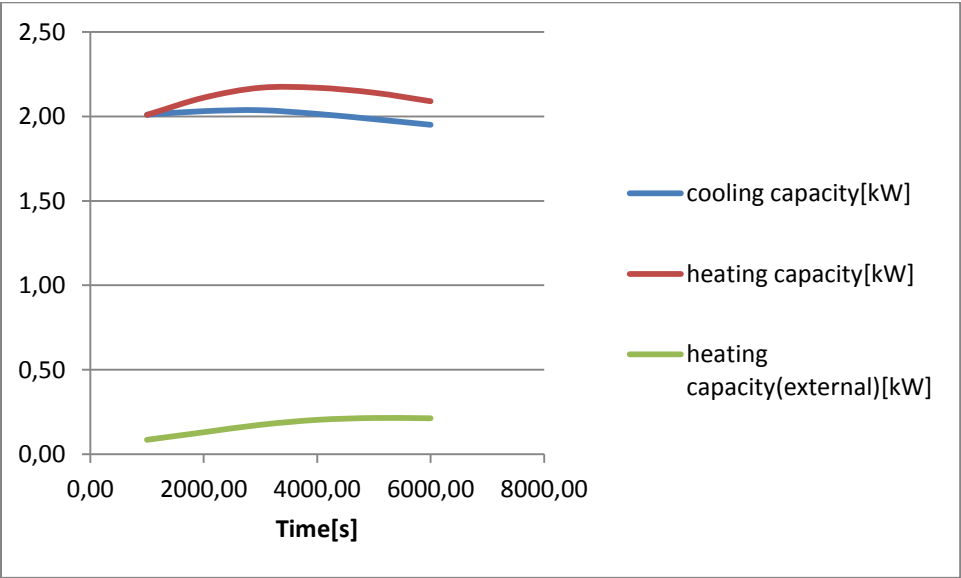

Figure 4. 67

Figure below shows the overheating before compression.

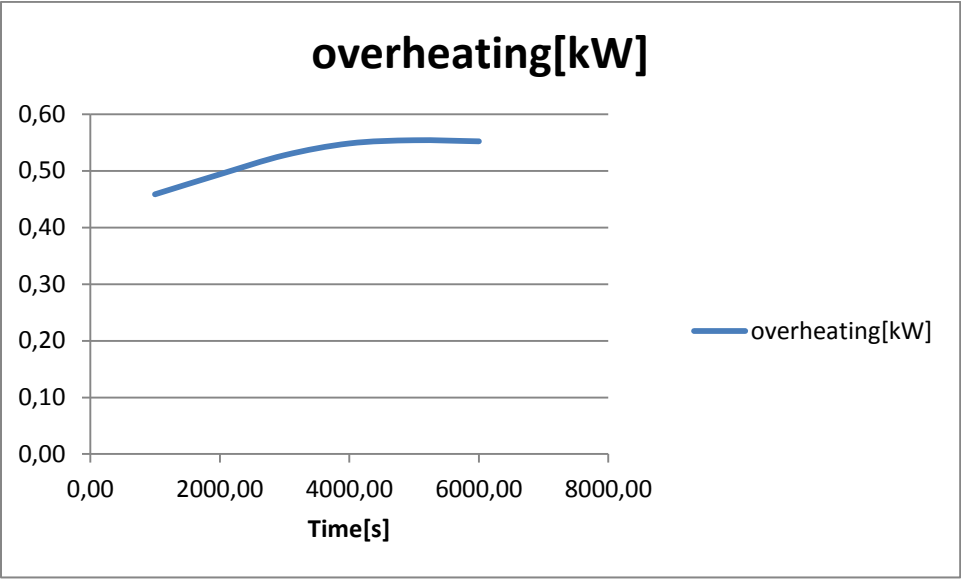

Figure 4. 68

Figure below shows the COP for the heating capacity and cooling capacity.

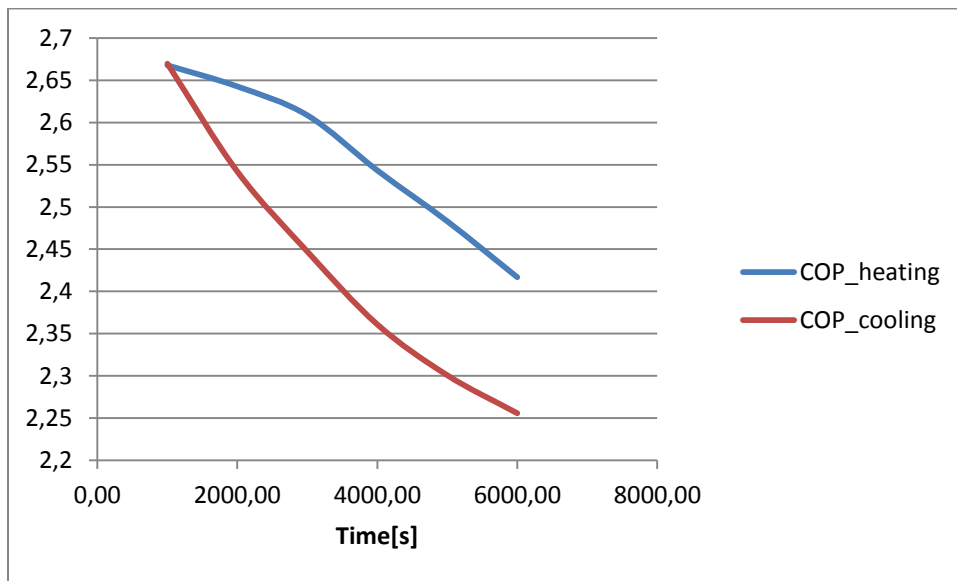

Figure 4. 69

Figure below shows the mass flow over time.

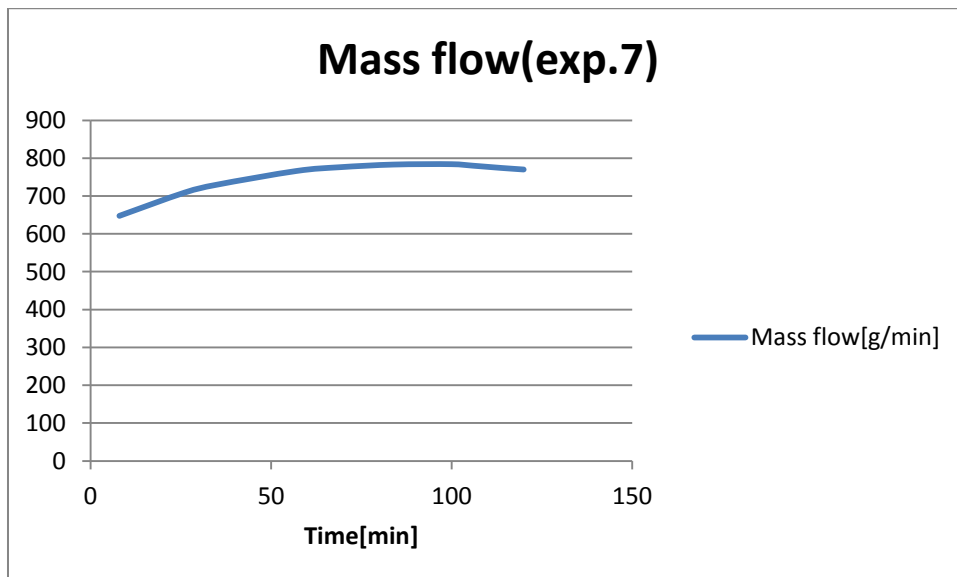

Figure 4. 70

Table below shows some of important summing-up values for this experiment.

Result values	
Water extracted	2,46 kg
Running time	120 minutes
COP_average(cooling)	2,429194
COP_average(heating)	2,560273
Compressor effect	0,822191 kW
Motor effect	0,19865 kW
Total effect	1,020841 kW
Mass flow	752 kg/min
Total power consumption	2,073 kWh
SMER	1,186686 kg/kWh

Table 4.9

4.3.8 Experiment nr.8

This experiment is carried out with small external gas cooler connected after 30 minutes (reduced refrigerant charge).

Figure below shows the pressure at evaporator (PI-1), compressor outlet (PI-2), external gas cooler outlet (PI-4) over the time.

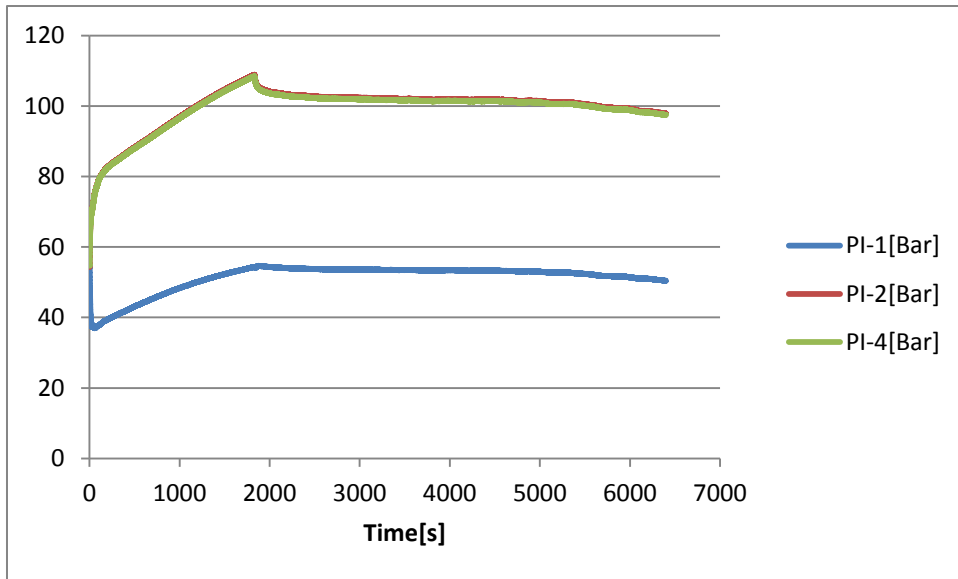

Figure 4. 71

Figure below shows the CO₂ temperatures at evaporator outlet, compressor outlet, external gas cooler inlet and outlet.

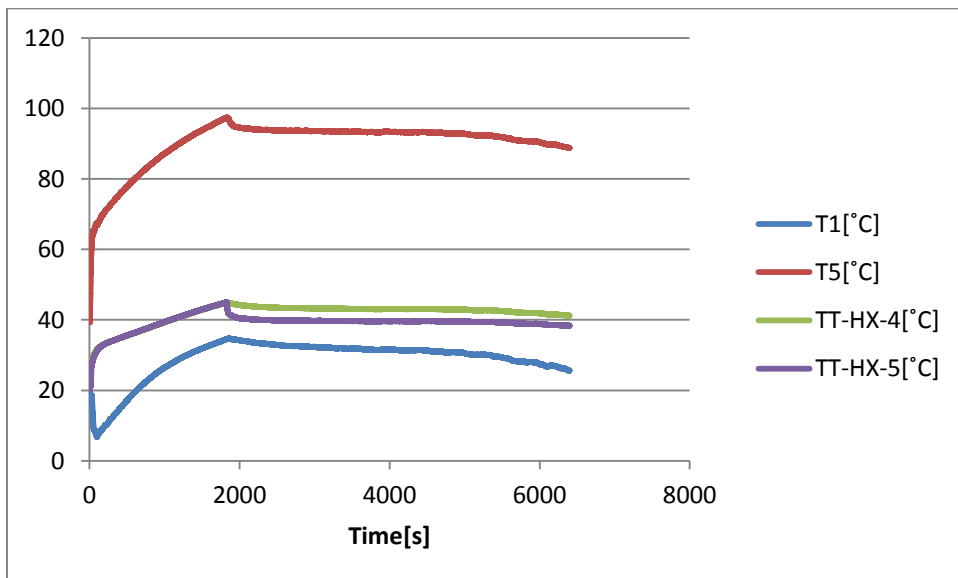

Figure 4. 72

Figure below shows the zoomed diagram for CO₂ temperature difference between inlet and outlet of the external gas cooler.

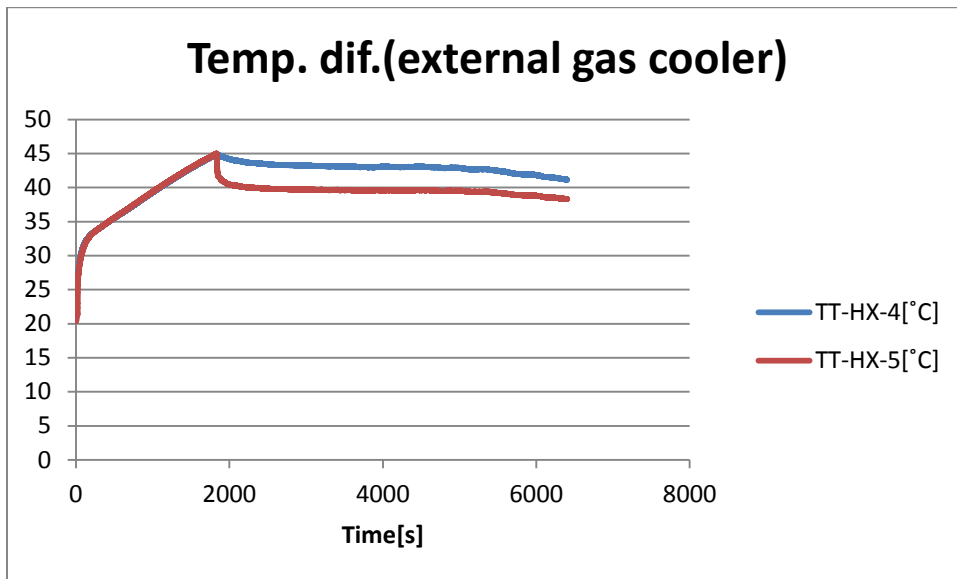

Figure 4. 73

Figure below shows the inlet and outlet relative humidity of the drum over time.

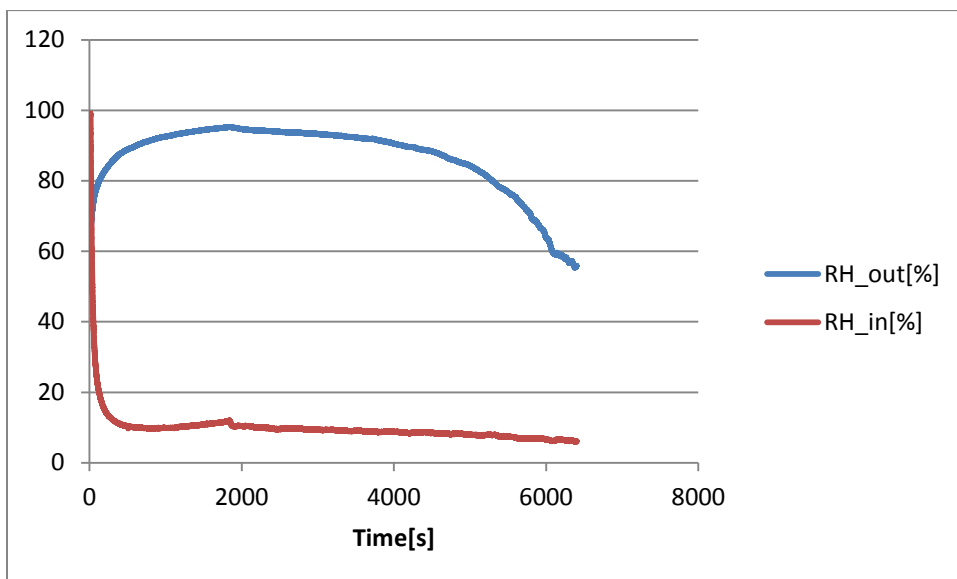

Figure 4. 74

Figure below shows the power consumption of the compressor and the motor used to run the drum

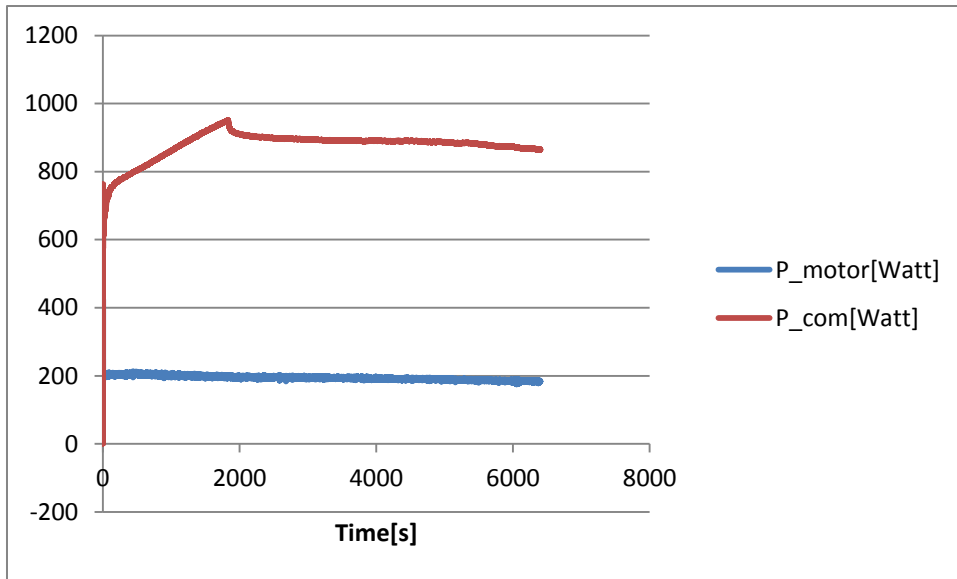

Figure 4. 75

Figure below shows the air temperature before drum, after drum and after flowing through evaporator.

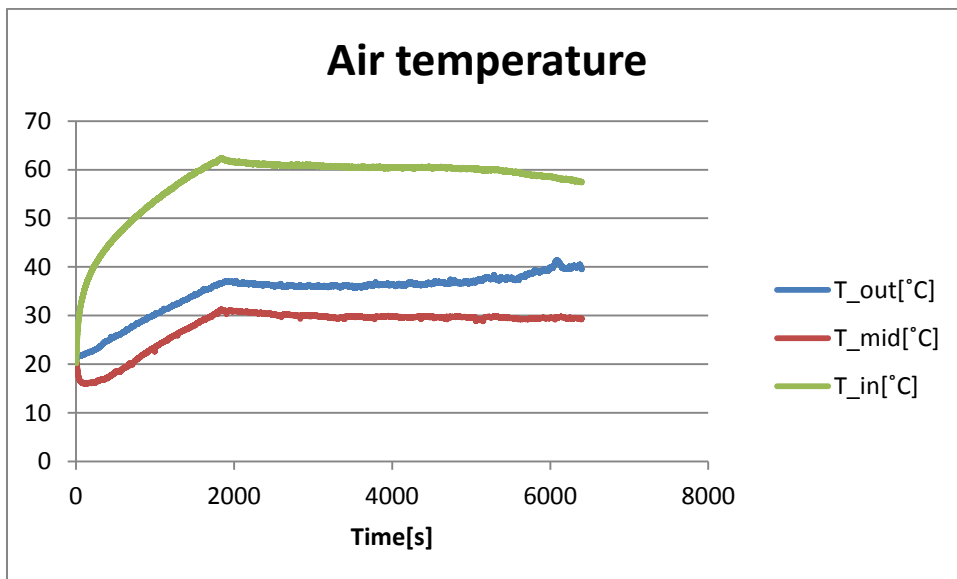

Figure 4. 76

Figure below shows the temperature difference between the inlet and outlet temperature of the air flowing through the external gas cooler.

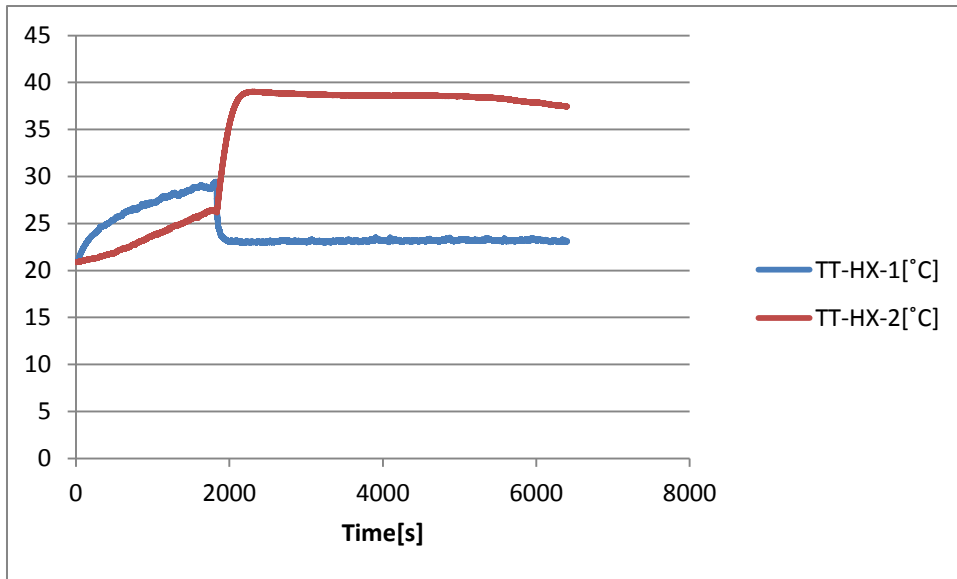

Figure 4. 77

In this project some data is extracted to calculate the performance of the evaporator, main gas cooler, external gas cooler, overheating and the COPs, and some data is extracted to draw p-h diagrams, the principle is to give a performance overview of chosen component and the heat pump system as a whole and the data is extracted when the system is relative stable.

Figure below shows cooling capacity of the evaporator, heating capacity of the main gas cooler and heating capacity of the external gas cooler.

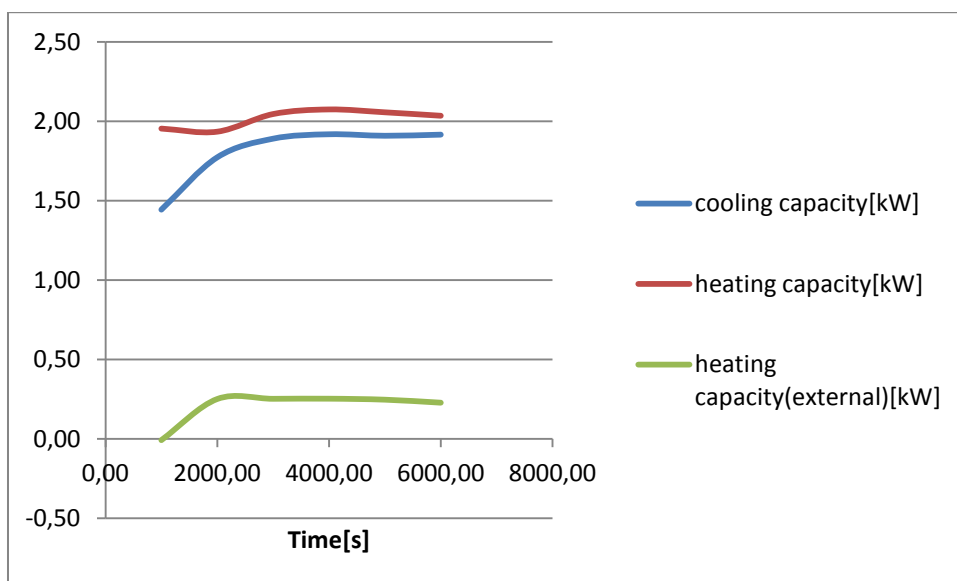

Figure 4. 78

Figure below shows the overheating before compression.

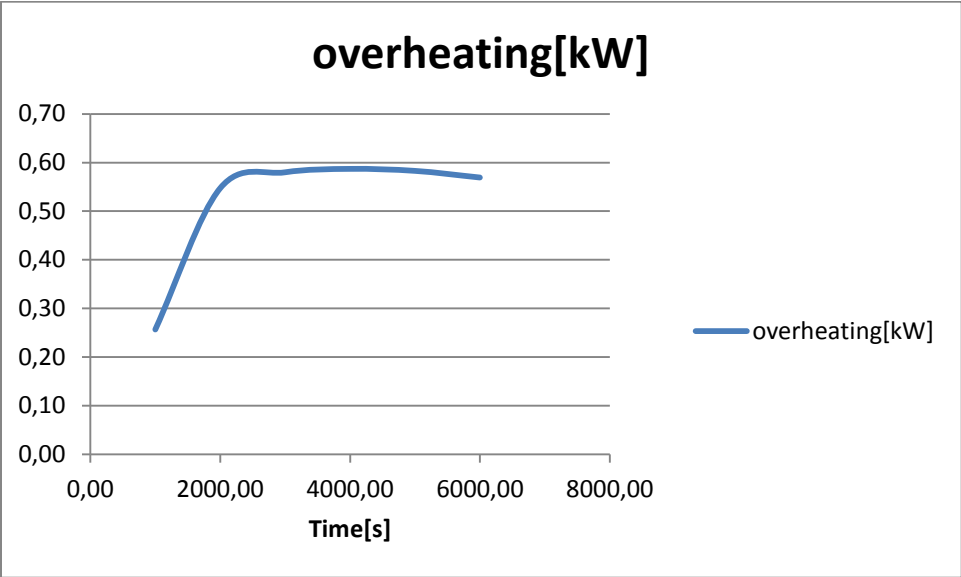

Figure 4. 79

Figure below shows the COP for the heating capacity and cooling capacity.

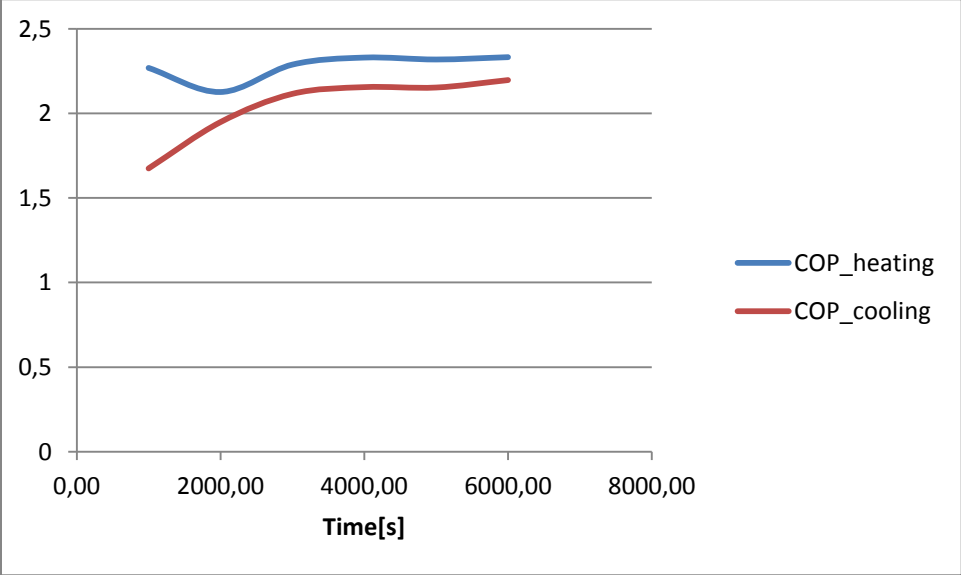

Figure 4. 80

Figure below shows the mass flow over time.

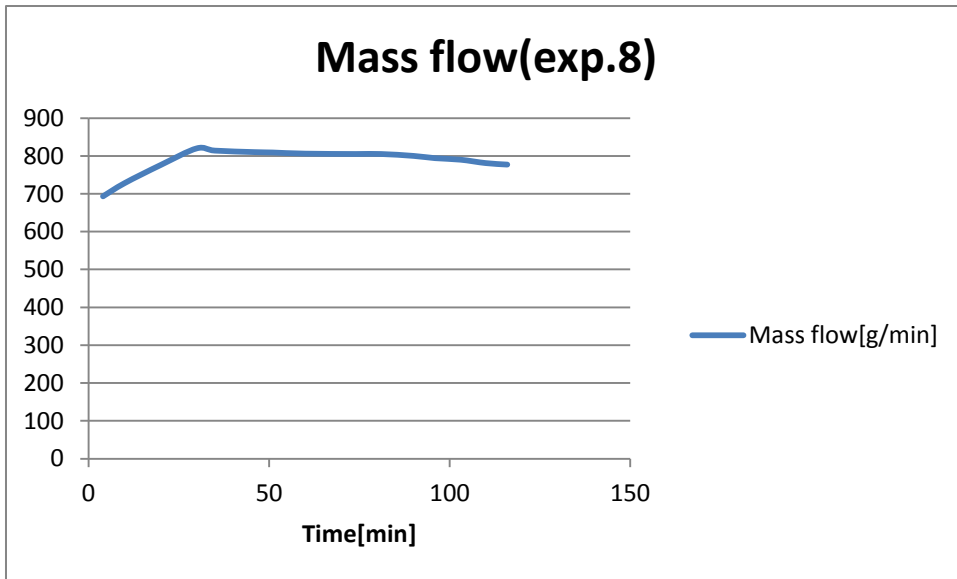

Figure 4. 81

Table below shows some of important summing-up values for this experiment.

Result values	
Water extracted	2,55 kg
Running time	116 minutes
COP_average(cooling)	2,040362
COP_average(heating)	2,276865
Compressor effect	0,875198 kW
Motor effect	0,193306 kW
Total effect	1,068503 kW
Mass flow	787,2 kg/min
Total power consumption	2,069 kWh
SMER	1,232479 kg/kWh

Table 4.10

4.3.9 Experiment nr.9

This experiment is carried out with large and small external gas coolers connected in series during the whole test (reduced refrigerant charge). More cooling is expected in this

experiment, from former experiment, the compressor power consumption should be lower than experiment nr 7.

Figure below shows the pressure at evaporator (PI-1), compressor outlet (PI-2), external gas cooler outlet (PI-4) over the time. The pressure level of each component is lower than experiment nr. 7 (small external gas cooler connected) as expected, but is higher than experiment nr.4 (large external gas cooler connected). The pressure level of each component is supposed to be lower than experiment nr.4 and 7, this gives another prove that the installed plate did reduce the “cooling effect”, which means, heat leakage from evaporator is considered as “a good thing” so that overheating is lower, thus lowered compressor power consumption.

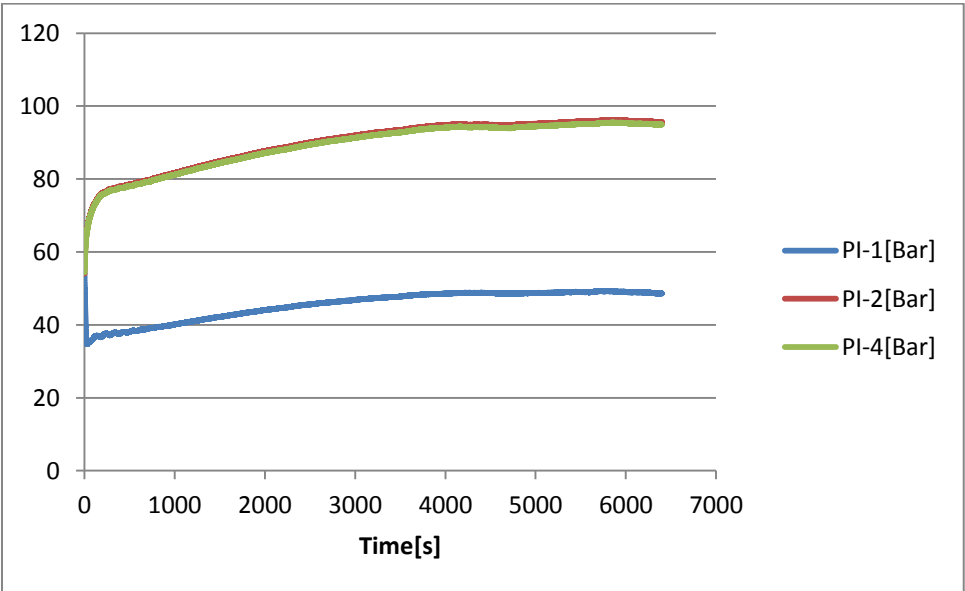

Figure 4. 82

Figure below shows the CO₂ temperatures at evaporator outlet, compressor outlet, external gas cooler inlet and outlet.

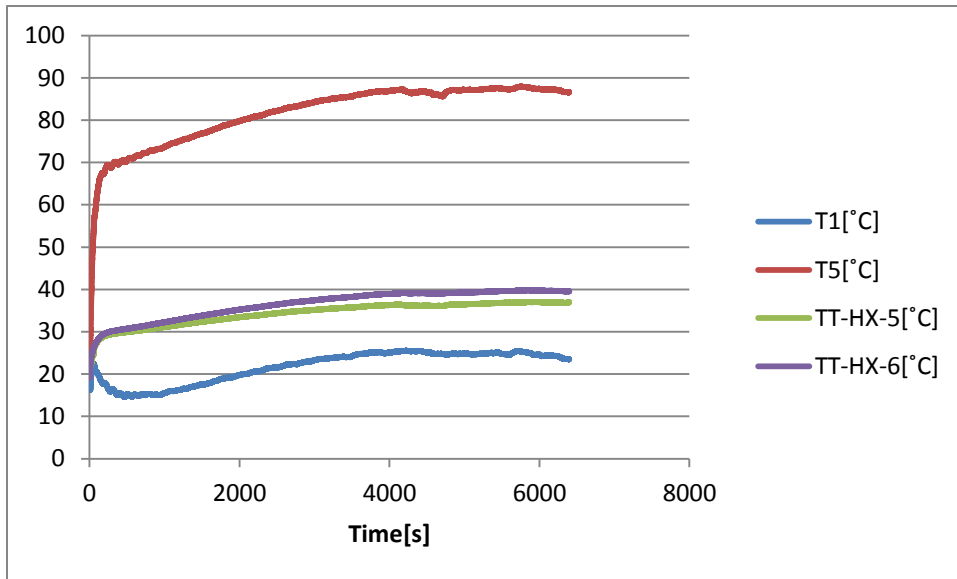

Figure 4. 83

Figure below shows the zoomed diagram for CO₂ temperature difference between inlet and outlet of the external gas cooler.

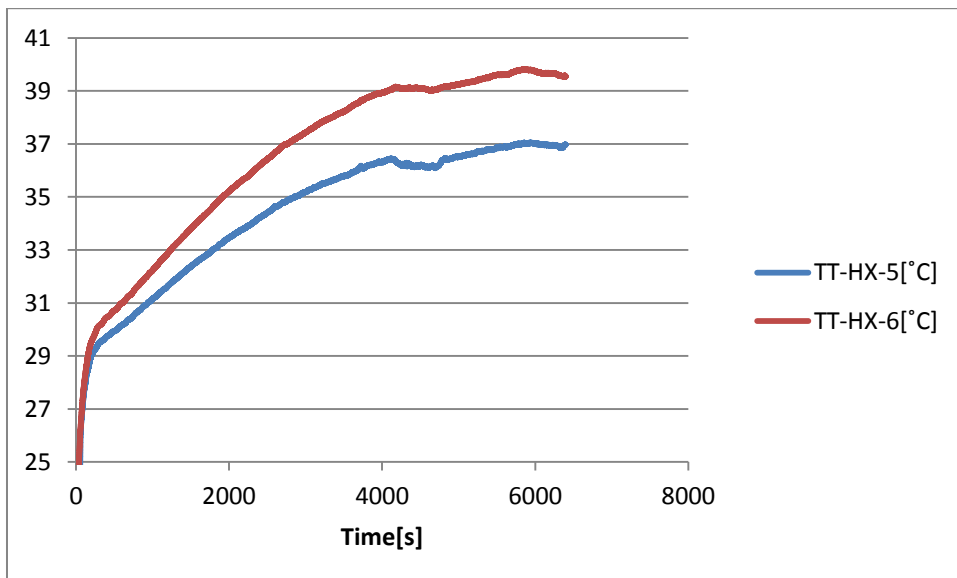

Figure 4. 84

Figure below shows the inlet and outlet relative humidity of the drum over time.

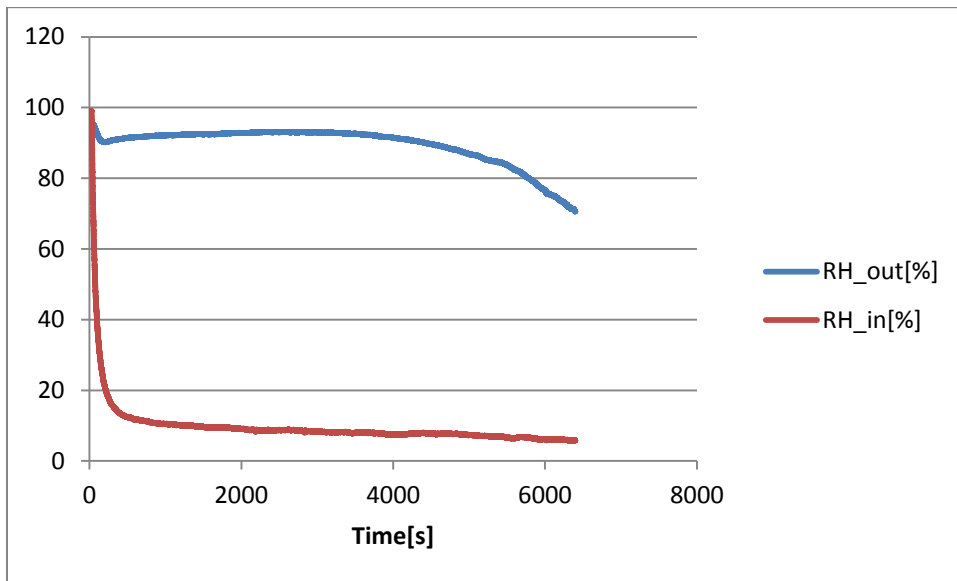

Figure 4. 85

Figure below shows the power consumption of the compressor and the motor used to run the drum. The average power consumption of the compressor is slightly lower than experiment nr.7.

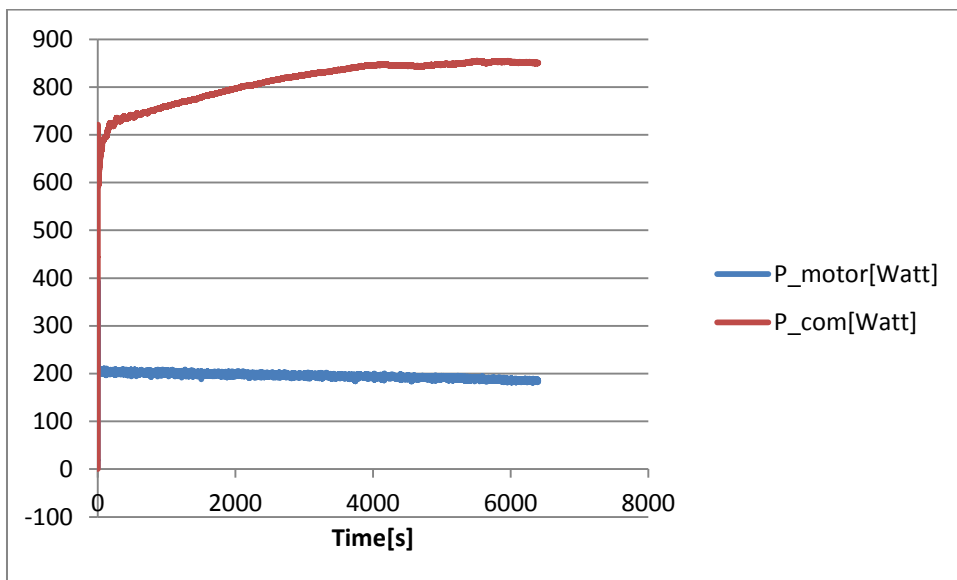

Figure 4. 86

Figure below shows the air temperature before drum, after drum and after flowing through evaporator.

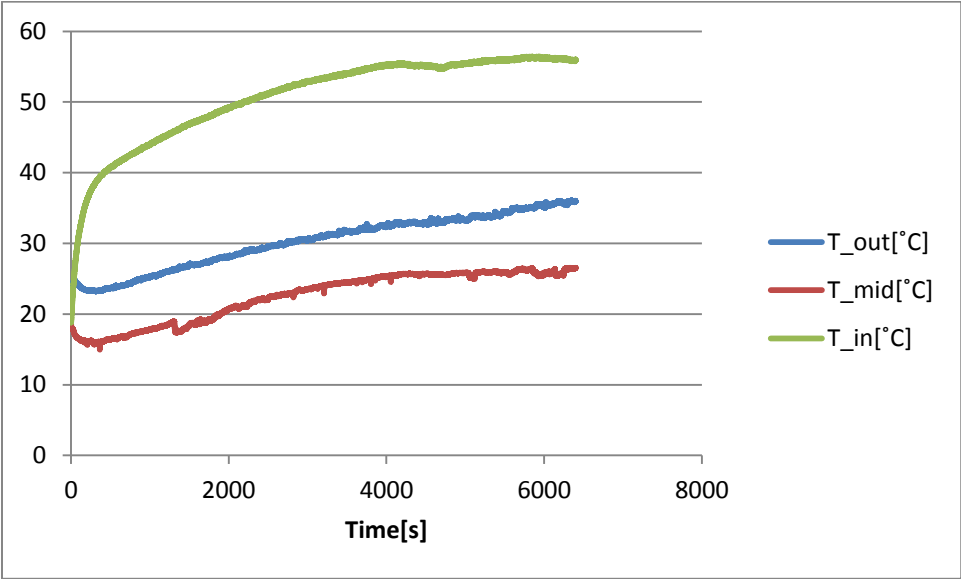

Figure 4. 87

Figure below shows the temperature difference between the inlet and outlet temperature of the air flowing through the external gas cooler. The temperature difference is slightly higher than experiment nr.7, which means the cooling effect using large and small external gas cooler in series is only a little bit better than only using a small external gas cooler and more air volume is needed to increase the cooling effect.

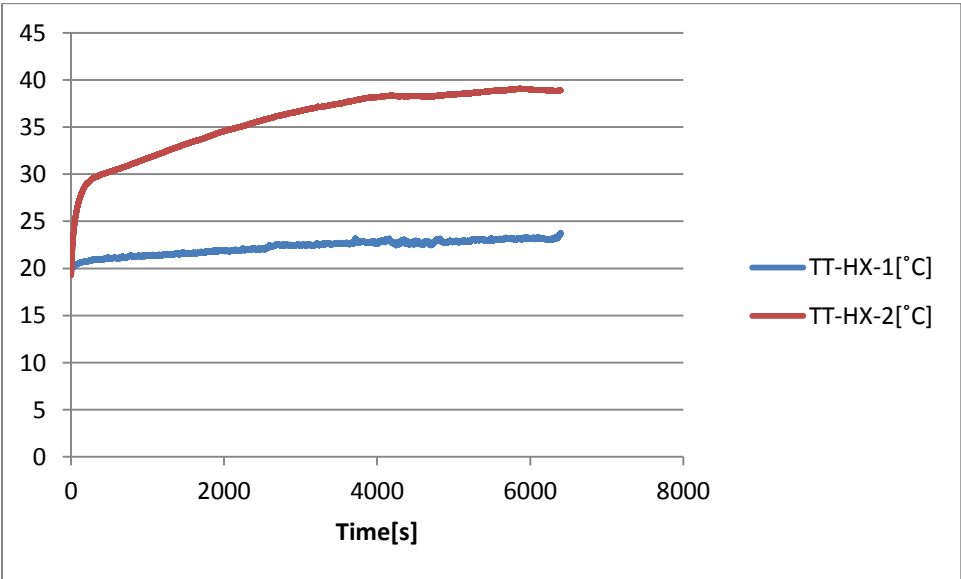

Figure 4. 88

In this project some data is extracted to calculate the performance of the evaporator, main gas cooler, external gas cooler, overheating and the COPs, and some data is extracted to draw p-h diagrams, the principle is to give a performance overview of chosen component and the heat pump system as a whole and the data is extracted when the system is relative stable.

Figure below shows cooling capacity of the evaporator, heating capacity of the main gas cooler and heating capacity of the external gas cooler.

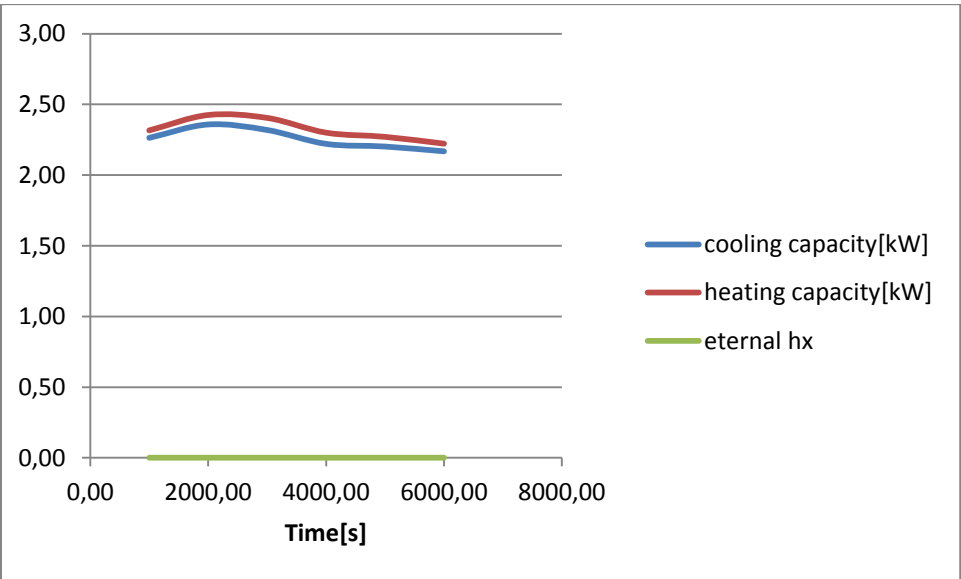

Figure 4. 89

Figure below shows the overheating before compression.

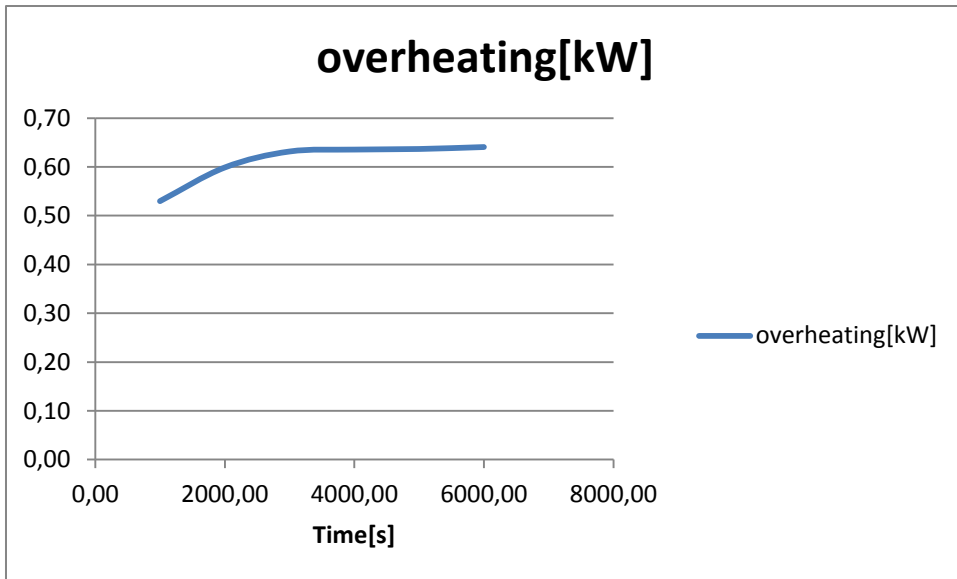

Figure 4. 90

Figure below shows the COP for the heating capacity and cooling capacity. The COPs is dropping down when the temperature and pressure level increase.

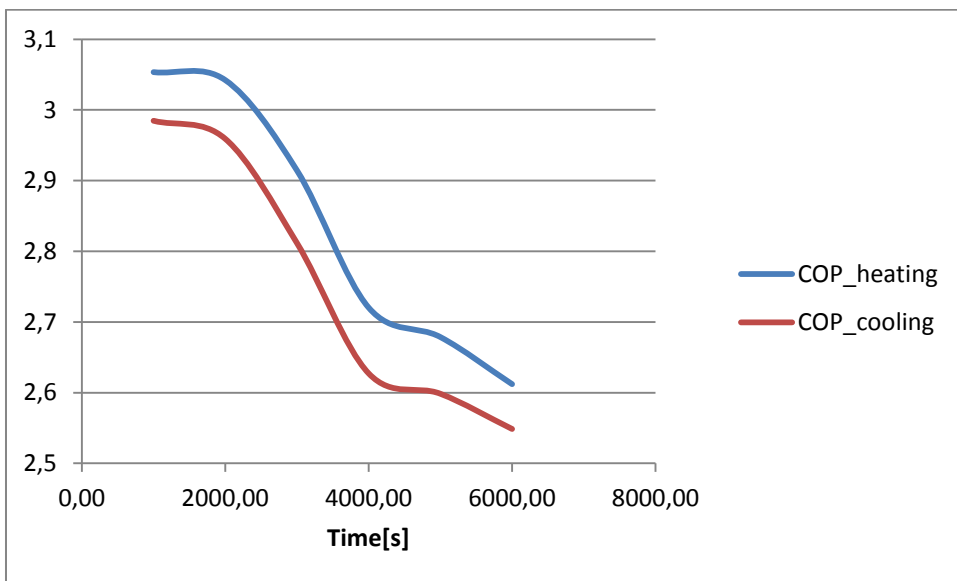

Figure 4. 91

Figure below shows the mass flow over time.

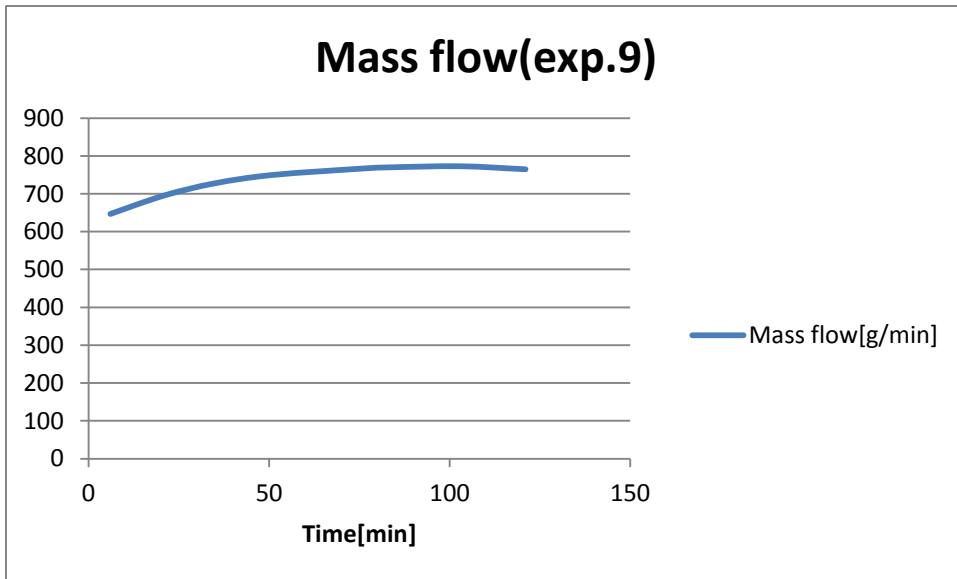

Figure 4. 92

Table below shows some of important summing-up values for this experiment.

Result values	
Water extracted	2,55 kg
Running time	121 minutes
COP_average(cooling)	2,754797
COP_average(heating)	2,836764
Compressor effect	0,815643 kW
Motor effect	0,193623 kW
Total effect	1,009267 kW
Mass flow	737 kg/min
Total power consumption	2,086 kWh
SMER	1,222435 kg/kWh

Table 4.11

4.3.10 Experiment nr.10

This experiment is carried out with large and small external gas coolers connected in series after 30 minutes (reduced refrigerant charge)

Figure below shows the pressure at evaporator (PI-1), compressor outlet (PI-2), external gas cooler outlet (PI-4) over the time.

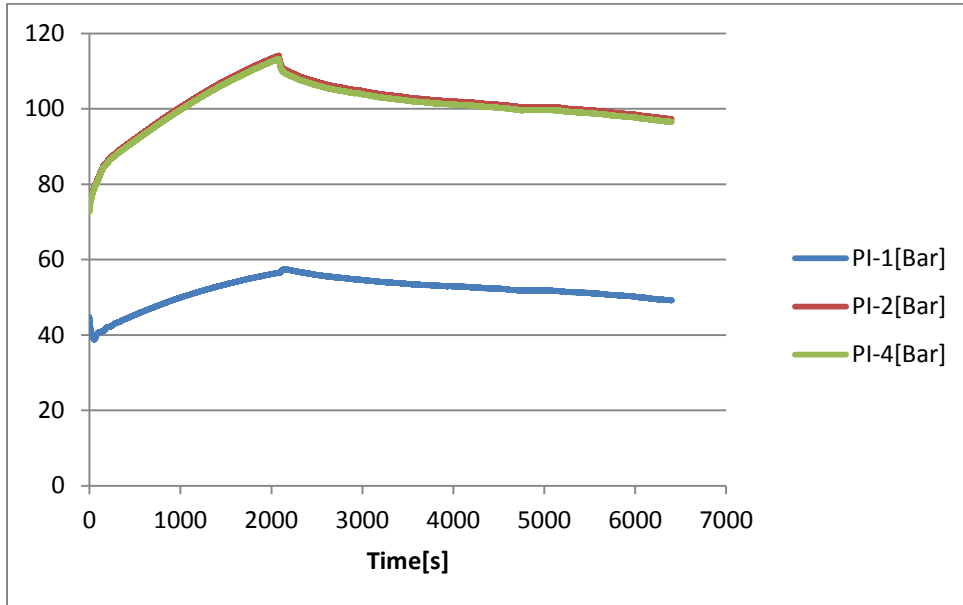

Figure 4.93

Figure below shows the CO₂ temperatures at evaporator outlet, compressor outlet, external gas cooler inlet and outlet.

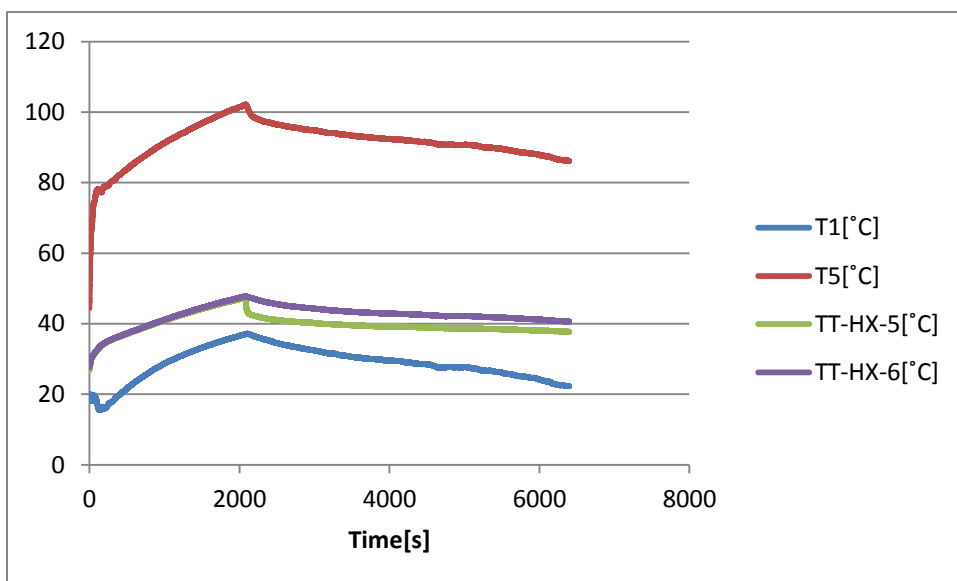

Figure 4.94

Figure below shows the zoomed diagram for CO₂ temperature difference between inlet and outlet of the external gas cooler.

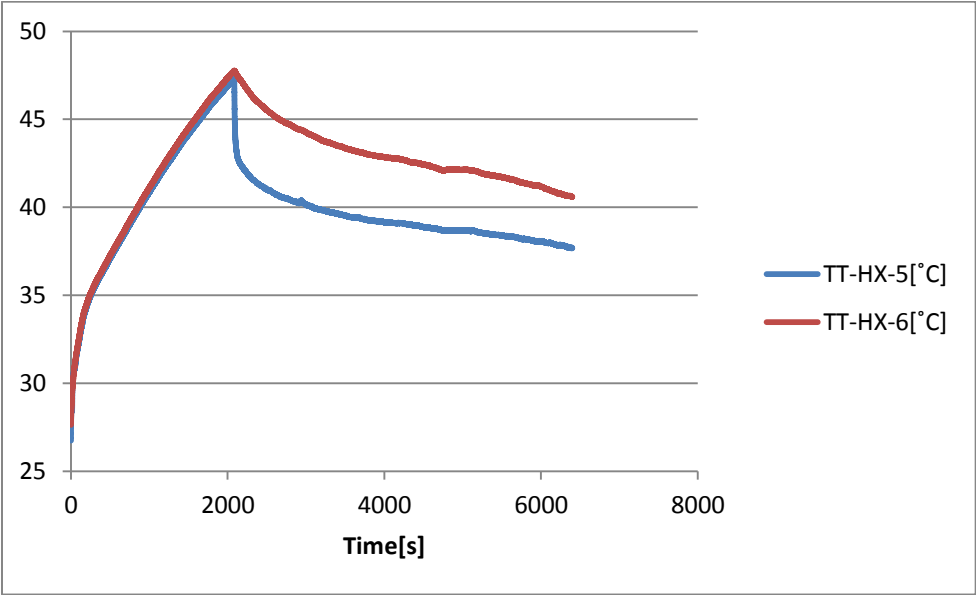

Figure 4. 95

Figure below shows the inlet and outlet relative humidity of the drum over time.

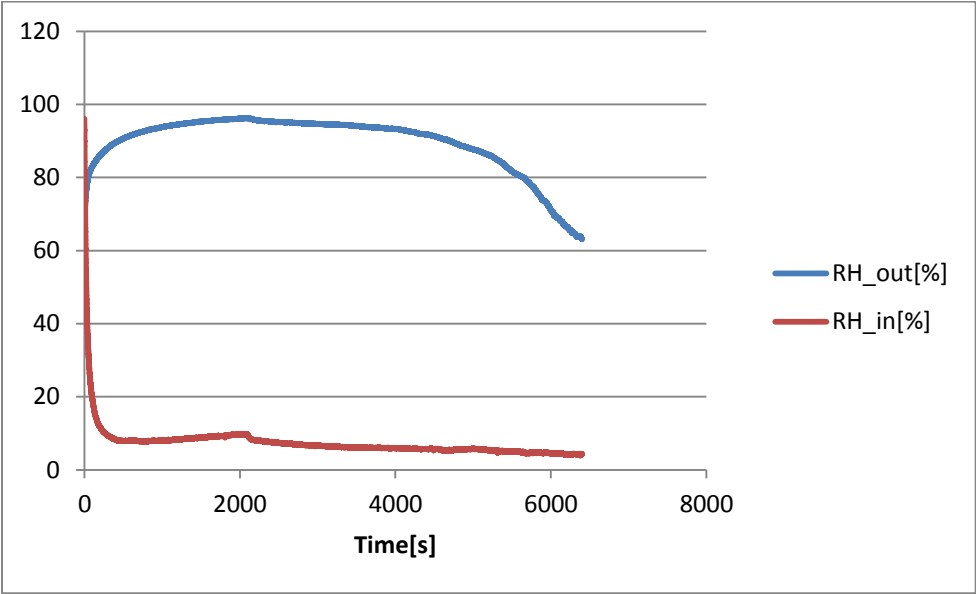

Figure 4. 96

Figure below shows the power consumption of the compressor and the motor used to run the drum

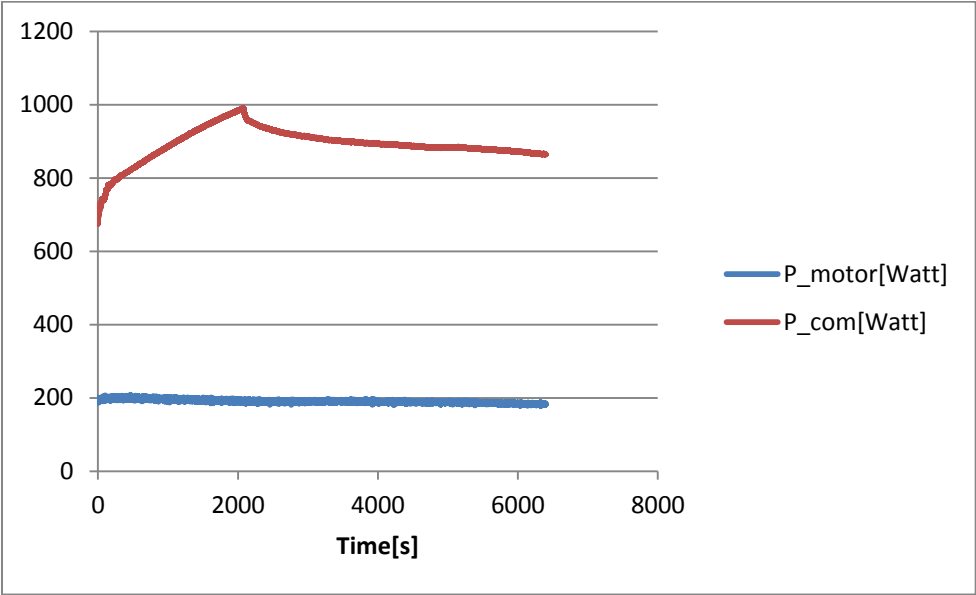

Figure 4. 97

Figure below shows the air temperature before drum, after drum and after flowing through evaporator.

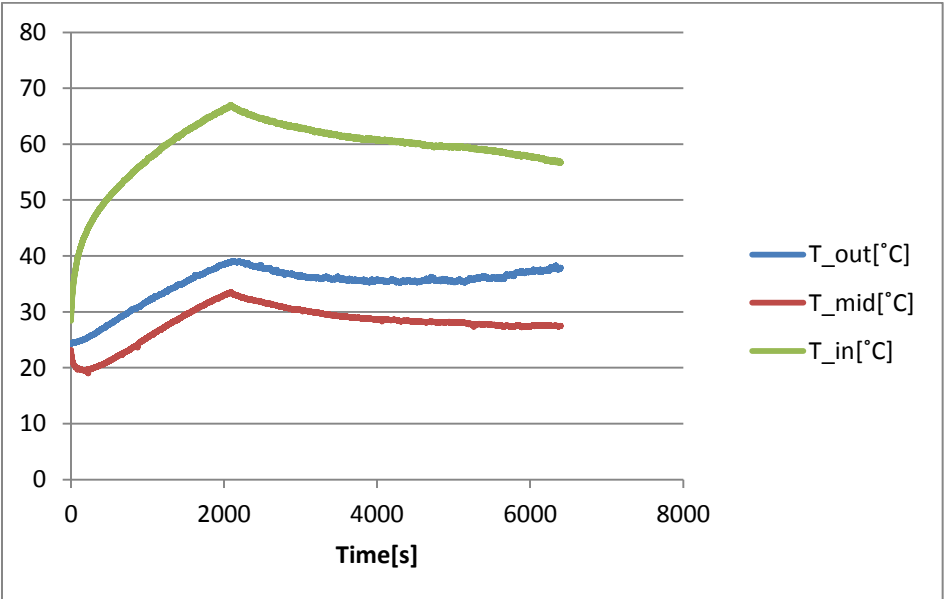

Figure 4. 98

Figure below shows the temperature difference between the inlet and outlet temperature of the air flowing through the external gas cooler.

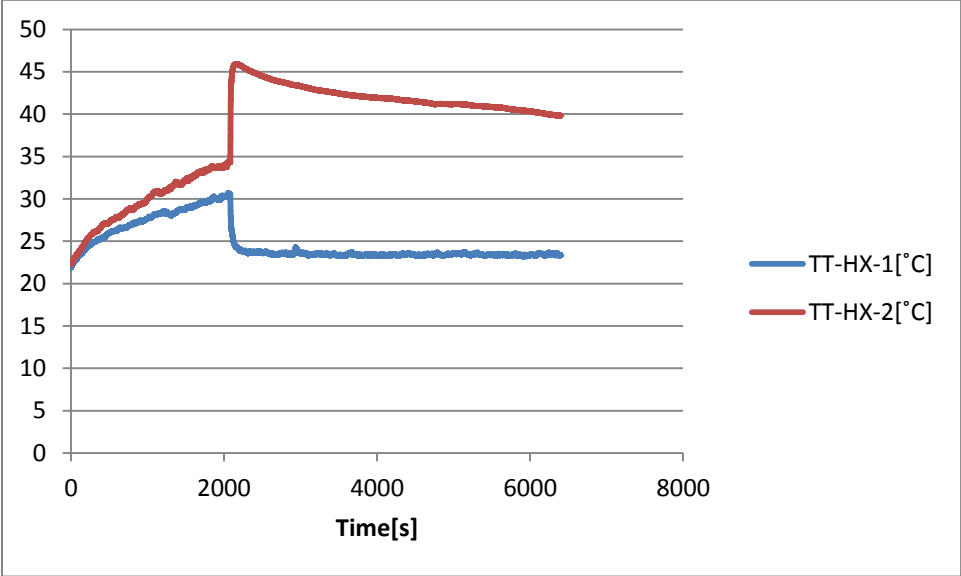

Figure 4. 99

Table below shows some of important summing-up values for this experiment.

In this project some data is extracted to calculate the performance of the evaporator, main gas cooler, external gas cooler, overheating and the COPs, and some data is extracted to draw p-h diagrams, the principle is to give a performance overview of chosen component and the heat pump system as a whole and the data is extracted when the system is relative stable.

Figure below shows cooling capacity of the evaporator, heating capacity of the main gas cooler and heating capacity of the external gas cooler.

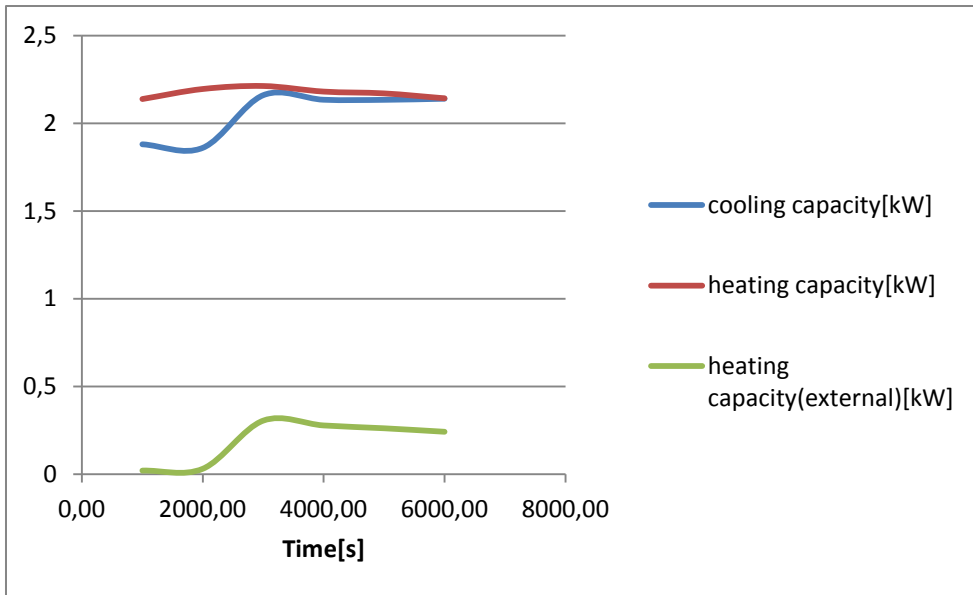

Figure 4. 100

Figure below shows the overheating before compression.

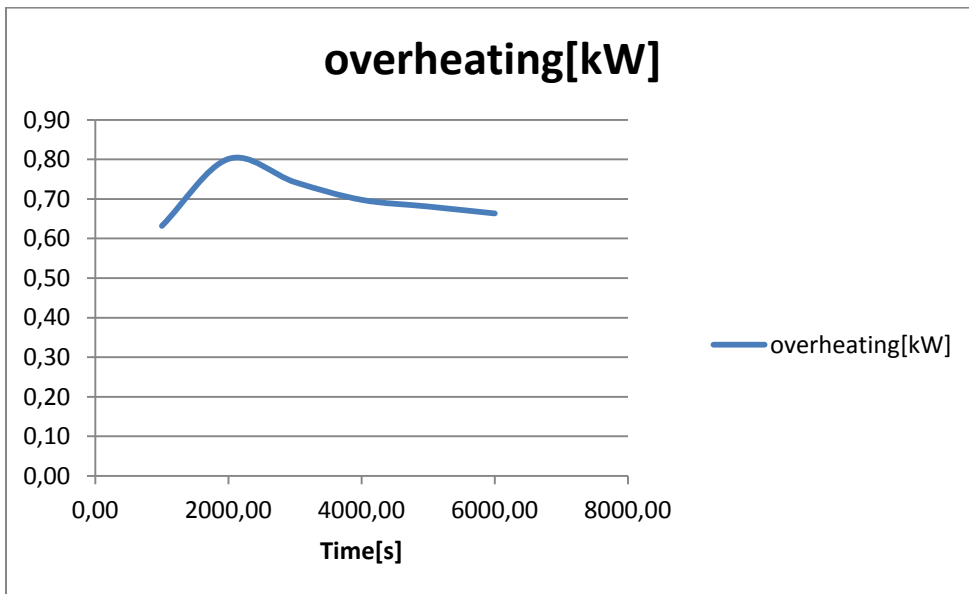

Figure 4. 101

Figure below shows the COP for the heating capacity and cooling capacity.

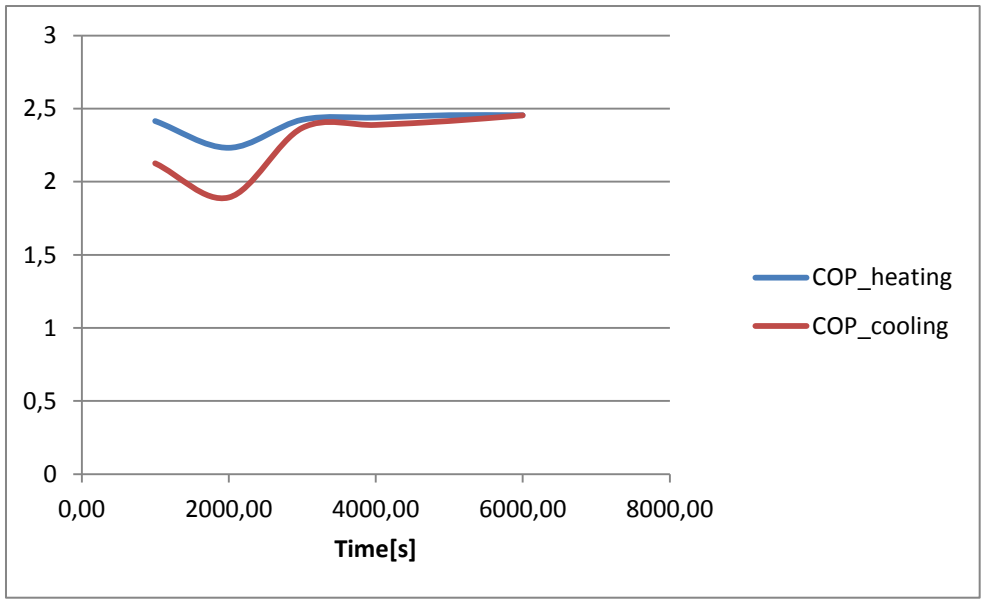

Figure 4. 102

Figure below shows the mass flow over time.

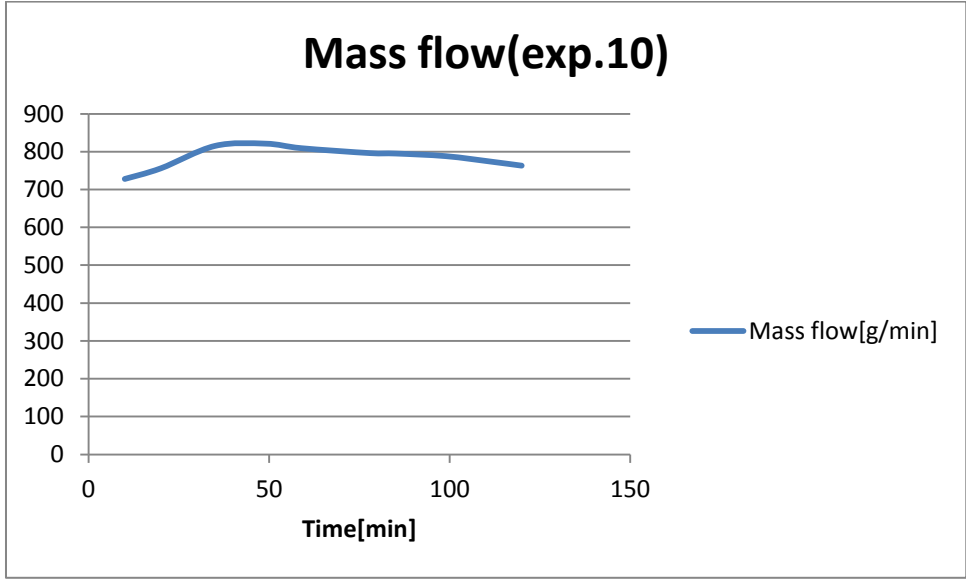

Figure 4. 103

Table below shows some of important summing-up values for this experiment.

Result values	
Water extracted	2,52 kg
Running time	120 minutes
COP_average(cooling)	2,273272
COP_average(heating)	2,403854
Compressor effect	0,887711 kW
Motor effect	0,189845 kW
Total effect	1,077556 kW
Mass flow	784,4 kg/min
Total power consumption	2,152 kWh
SMER	1,171004 kg/kWh

Table 4.12

4.4 Comparison and discussion

The result data is listed in the table below, and will be compared.

Experiments	Unit	1	2	3	4	5	6	7	8	9	10
Water extracted	kg	2,58	2,6	2,42	2,48	2,47	2,4	2,46	2,55	2,55	2,52
Running time	minutes	105	102	100	114	119	124	120	116	121	120
COP_average(cooling)		2,905104	2,178272	1,27516	2,839321	2,729849	2,688723	2,429194	2,040362	2,754797	2,273272
COP_average(heating)		2,628237	2,407042	2,454399	3,292858	3,218536	3,158314	2,560273	2,276865	2,836764	2,403854
Compressor effect	kW	0,850741	0,957268	0,980879	0,642618	0,680961	0,68948	0,822191	0,875198	0,815643	0,887711
Motor effect	kW	0,203588	0,200055	0,196111	0,203579	0,200156	0,199902	0,19865	0,193306	0,193623	0,189845
Total effect	kW	1,054329	1,157323	1,17699	0,846196	0,881117	0,889382	1,020841	1,068503	1,009267	1,077556
Mass flow	kg/min	999	1010	1016	666,5455	728,1429	739,5833	752	787,2	737	784,4
Total power cons.	kWh	1,876	1,996	2,003	1,611	1,746	1,844	2,073	2,069	2,086	2,152
SMER	kg/kWh	1,375267	1,302605	1,208188	1,539417	1,414662	1,301518	1,186686	1,232479	1,222435	1,171004

Table 4.13

Compared all the experiments, the high temperature and pressure at high pressure side happens always when the external gas cooler is not connected, although high temperature gives a better heat capacity for heating the air flow, the cooling capacity is always dropping at

the same time, the power consumption of the compressor is always much higher and when compressor works at too high pressure and high temperature, the life time will be reduced.

The relative humidity diagrams for all the experiments are an indication of water extraction. When the relative humidity is beginning to drop, it means the fabric is beginning to become "dry". Of all the experiment, experiment nr1-3 have the shortest time when the relative humidity is decreasing, while experiment nr. 7-10 have the longest. It means the heating capacity plays more important role for water extraction rate than cooling capacity. And also higher refrigerant charge will also help reduce the running time.

The highest air temperature before going to drum appears in experiment nr.3, which is around 80°C, and experiment nr.4-10 has the highest air temperature ranging from 53°C to 60°C, it means that the refrigerant charge the un-connecting external gas cooler situation plays an important role for heating. At the same time, experiment nr.9 has the lowest air temperature after evaporation, so it gives a good cooling capacity amount other experiments.

The maximum temperature difference between external gas cooler inlet and outlet appears at experiment nr.10 just after the gas coolers in series is connected, which is 4°C. But when the system is becoming relative stable, amount all the experiments the temperature difference between external gas cooler inlet and outlet stays around 2°C (the gas coolers connected in series has a temperature difference at round 2.4°C, while the small gas cooler has a temperature difference at around 1.8°C), the difference is relative small, the reason is that the air flow to cooler the gas cooler is not sufficient.

From the summing-up result values it can be seen that the shortest running is with experiment nr.3, 100 minutes, and the smallest total power consumption appears at experiment nr.4, which is 1.611kWh, compared to experiment nr.3, which consumes 2,003kWh of energy, it is 24,3% more of energy consumed. Although both experiment nr.2 and nr.3 have short running time, but the pressure of each experiment exceed 120 bars at high pressure side, which is considered as abnormal working condition, and the running time is only 14 minutes or less than experiment nr.4.

From the SMER number it can be also seen that experiment nr.4 has the best result, the SMER number is defined as the extracted water mass divided by the total energy consumption.

P-h diagram for the whole process is drawn below for experiment nr.4. Three circles are drawn representing the beginning, middle and end stage. Although this diagram is drawn for experiment nr.4, all other experiments have similar tendency. The curve that lies at bottom is the begging stage, the pressure and temperature level are still low, the upper curve is when pressure and temperature peaks at a certain point, and the curve that lies in the middle is when the relative humidity is dropping (the fabric is drying off), so will the temperature and pressure level.

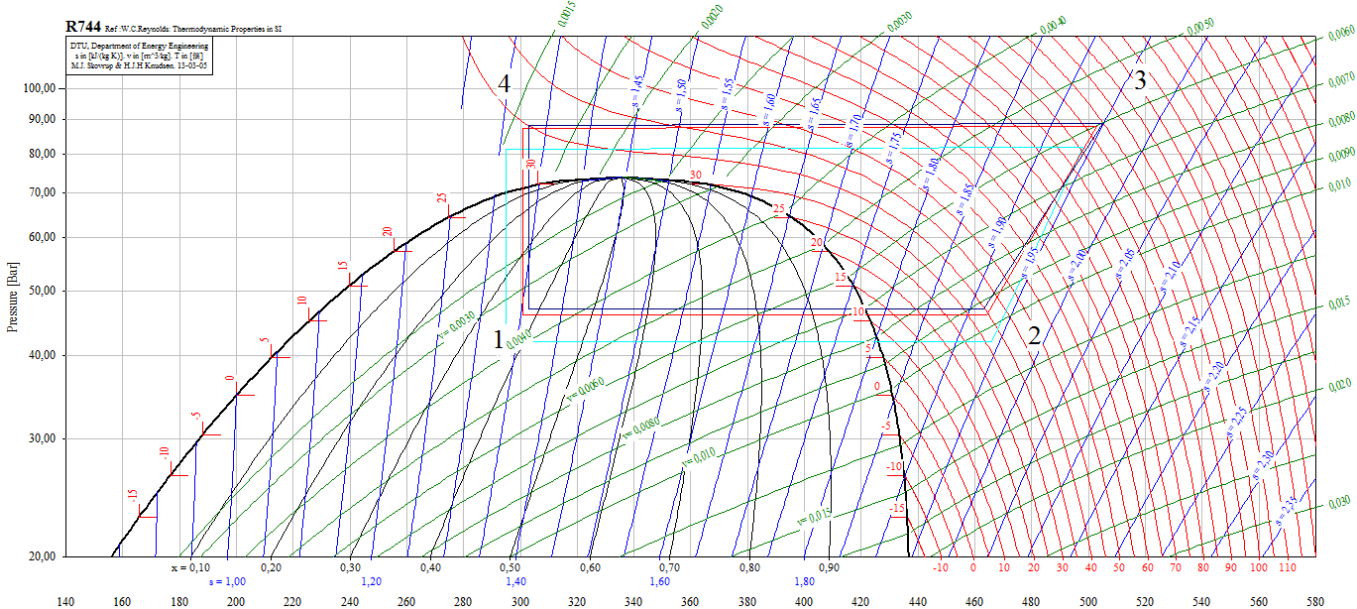

Figure 4. 104 Process circle for experiment nr.4

5 Conclusion

The CO₂ heat pump has proven its advantage in drying drum, since it can benefit both from the heating capacity (to heat air) and cooling capacity (to condense water). Compared to direct heating drum dryers, the energy consumption for using heat pump is always lower.

From the result data it can be seen that there are several factors that have influence on the performance of the CO₂ heat pump.

The refrigerant charge plays an important role for the compressor power consumption. Too high refrigerant charge will result in a very high power consumption. It is because that high refrigerant charge leads to high mass flow on the high pressure side, and the capillary tube as expansion device in this project don't have the ability to regulate the flow (by regulating pressure), so there is limiting mass flowing through capillary tube per time, and the high pressure side is in a way "stuck". That's why the compressor needs high power to increase the pressure and push the refrigerant through capillary tube, increasing pressure means increasing temperature both on high pressure side and low pressure side, with a higher temperature on evaporator, less water will be condensed, which leads to another downside of too high refrigerant charge. The advantage is that high discharge temperature after compression will give a high heat transfer between the air and CO₂, thus higher air temperature going through the drum, high temperature of air will have the ability to carry more water vapor. From the results it can be proven that although less running time is needed to dry the fabric with high refrigerant charge, it still results in higher total power consumption.

Too less refrigerant charge will lead to long running time, since the motor power consumption is relative stable over time, and is not very much influenced by the CO₂ heat pump performance. So long running time will still not give good result. It means that there is always an optimal amount of refrigerant charge.

A certain level of overheating is needed to make sure there is no liquid coming into compressor, but when the overheating is too much, it will be a waste of compressor power. There are several reasons causing too much overheating. For example: self-regulated capillary tube makes various evaporation pressure and saturated, thus uncertain heat transfer between the air flow and CO₂, which can give an unnecessary high overheating before refrigerant coming into compressor.

Sufficient air flow is also very important to maintain a good performance of the system. At beginning, some small test were carried out. It was noticed that the relative humidity out of drum is almost 100%, and at the mean time the water extraction rate is very low, to dry off the fabric with same amount of water can take even one more hour. The reason is because the

filter was not cleared and was blocking the air flow. So with a reduced air flow less water can be absorbed and at the same time the compressor and motor were not much influenced and were working at full power, which gives much higher energy consumption.

Air flow used to cool the external gas cooler is also considered as not enough. The power of the fan is 12Watt, it can't give sufficient air amount. The outlet and inlet temperature of CO₂ does not differ much with different size of external gas cooler connected while the size of the small external gas cooler is around 1/3 of two external gas cooler connected in series. It means that there is not enough air to cool down CO₂ since the heating capacity of the air is very low.

Although the air flow doesn't give very good cooling, it has still been proven that the external gas cooler plays an important role here. At beginning of some experiments, the external gas cooler is not connected, and has been shown from the result that the discharge temperature before compressor is increasing rapidly compared to that when the gas cooler is connected, the power consumption of the compressor can be 100W to 200W higher than when the gas cooler is connected. As mentioned above, when the external gas cooler is not connected, it does give a benefit for the heating capacity, but also a lowered cooling capacity for the evaporator. And also when the external gas cooler is connected after 30 minutes or 60 minutes, the discharge temperature of CO₂ before compressor is very slowly decreased, which means that the overheating is still remaining on a high level, and the power consumption of compressor is still higher than that when the external gas cooler is connected in the beginning of experiment.

The compressor used in this project is a one stage compressor, the experimental data in this project is compared with the data from ASKO, the manufactory. And it looks like the compressor itself is working fine. But one stage compressor has its own restriction, the power consumption is high compared to two-stage compressor. According to the people from ASKO, the plan is to reduce the whole power consumption to 1.37kWh (this number is coming from ASKO and they are testing a heat pump using R134a as refrigerant), and the best result is 1.69kWh from experiment nr.4.

Some suggestions will be made based on the conclusions at next chapter.

6 Further work

From the experiment results and conclusions, some suggestion will be made for further development and optimization.

- Too much overheating, more length of the capillary tube or manually controlled expansion valve may help.
- Optimization of refrigerant charge.
- Change a new fan to increase the air flow for the external gas cooler or gas cooler installed in parallel.
- Compressor can be replaced into a new two-stage compressor to increase the energy efficiency

Reference

- [1] **Hekmat, D.; Fisk, W.J.** Improving the Energy Efficiency of Residential Clothes Dryers, NTIS report number LBL 16813, 1983.
- [2] **Winstel, F.H.** Apparatus for Recovery of Heat from Exhaust Gasses of Dryer. US Patent No. 4,028,817, 1975.
- [3] **Bansal PK, Braun JE, Groll E.** Improving the energy efficiency of conventional tumbler clothes drying systems. Int. J. Energy Res [in press].
- [4] **Takushima A, Inoshiri R, Okada T.** Condensation performance of air-cycle dryer system. Preliminary Proceedings of the 4th IIR-GustavLorentzen Conference on Natural Working Fluids, Purdue University, USA, 2000. p. 465–71.
- [5] **G. Lorentzen, J. Pettersen,** A new, efficient and environmentally benign system for car air conditioning, Int J Refrig 16 (1993) 4–12.
- [6] **G. Lorentzen,** Revival of carbon dioxide as a refrigerant, Int J Refrig 17 (1994) 292–300.
- [7] **G. Lorentzen,** The use of natural refrigerant: a complete solution to the CFC/HCFC predicament, Int J Refrig 18 (1994) 190–197
- [8] **Tans, Pieter.** "Trends in Carbon Dioxide". NOAA/ESRL. Retrieved 2009-12-11.
- [9] **Honghyun Cho, Changgi Ryu, Yongchan Kim, Ho Young Kim,** Department of Mechanical Engineering, Korea University, Anam-Dong, Sungbuk-Ku, Seoul 136-701, South Korea
- [10] International Standards: Compatibility of cylinder and valve materials with gas content; Part 1: ISO 11114-1 (Jul 1998), Part 2: ISO 11114-2 (Mar 2001)),
- [11] **Trygve Magne Eikevik, Havard Rekstad, Asmund Elnan,** Norwegian University of Science and Technology, Development of new heat pump cloth dryer with CO₂ as working fluid(2013)
- [12] **Ahmed BENSAFI - Bernard THONON,** Rapport 2414173, Transcritical R744 (CO₂) heat pumps, Technician's Manual

[13]F. Poggia, H. Macchi-Tejedaa, D. Leducqa, A. Bontempsb, Refrigerant charge in refrigerating systems and strategies of charge reduction, Cemagref, Refrigerating Process Research Unit, BP 44, 92 163 Antony Cedex, France

Appendices

Appendix A: p-h diagram for Carbon Dioxide Refrigerant

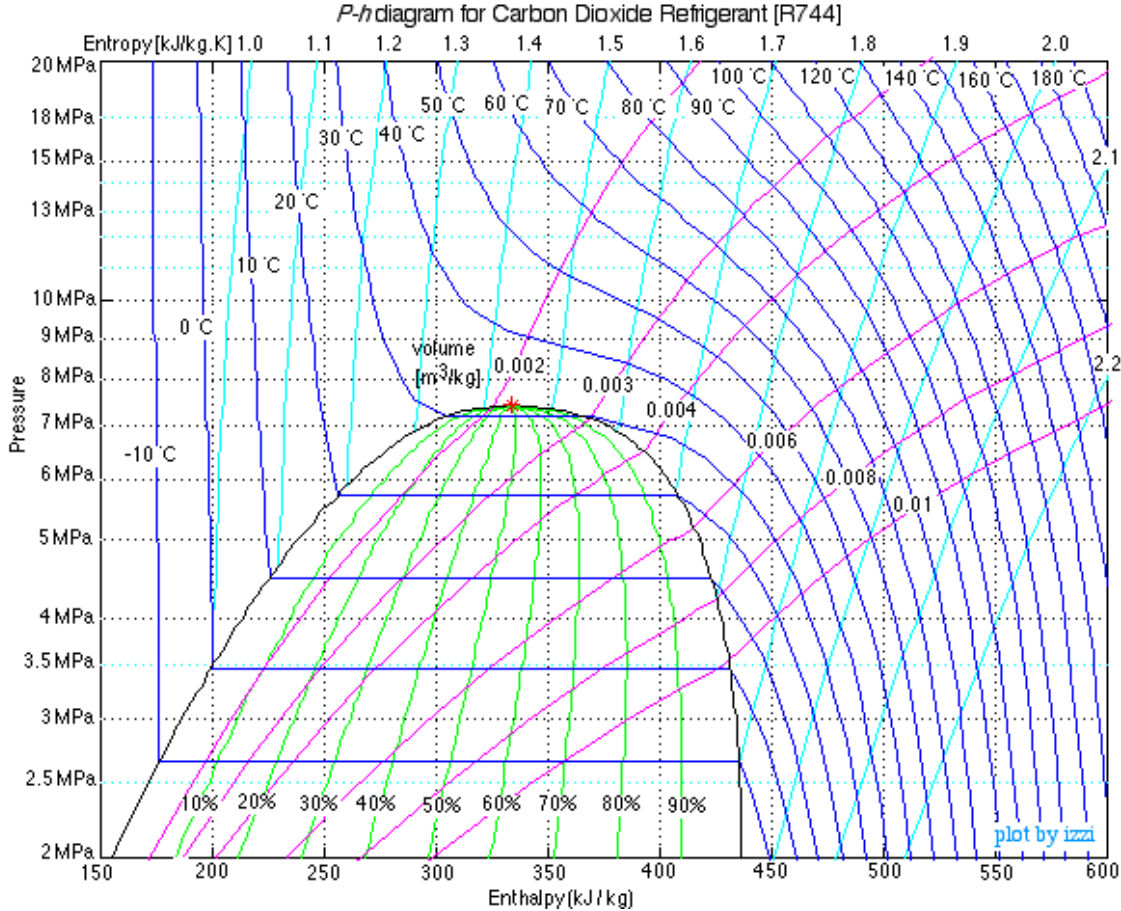

Figure A. 1

Appendix B: System failure

System failure to be repaired or needed to be taken care of:

- Thermal couple long retardness of reaction time, which results in measurement error.
- Labview crashed sometimes, have to restart, will cause problem if the system is still a test

- Sensor T3 has problem, bad isolation(temperature is too high to be true), and crashed sometimes in the result data(sometimes T3 shows only value zero, sometimes value vibrates.)
- Temperature T5 is sometimes too low (after compression the entropy is decreasing instead of increasing according to the temperature.)
- Too filters near the drum dryer door need to be cleaned, if not, may greatly influence the air flow
- The default setting for the Labview is to input data every 0,2 seconds, it is not necessary to have so many data, too many data will cause problems when using excel 2007 or under, excel 2007 can only support 32000 data in one diagram. So it is assumed that it is ok if the data input is per 1 sec.
- The flow meter is not connected to the Labview, measurement points had to be written down manually, that will cause calculation problem, extra work and increased uncertainty.

Appendix C: Calculation of the refrigerant charge

components	tube length[m]	tube diameter [m]	cross section[m ²]	Volume[m ³]	v[m ³ /kg]	flow discharge [kg]
evaporator	2,42	0,0050	1,96344E-05	4,74497E-05	0,00365	0,013
	2,42	0,0050	1,96344E-05	4,74497E-05	0,00452	0,010498
	2,42	0,0050	1,96344E-05	4,74497E-05	0,00512	0,009268
	2,42	0,0050	1,96344E-05	4,74497E-05	0,00578	0,008209
	2,42	0,0050	1,96344E-05	4,74497E-05	0,00644	0,007368
	2,42	0,0050	1,96344E-05	4,74497E-05	0,00706	0,006721
gas cooler	3,62	0,0050	1,96344E-05	7,11419E-05	0,00415	0,017143
	3,62	0,0050	1,96344E-05	7,11419E-05	0,0036	0,019762
	3,62	0,0050	1,96344E-05	7,11419E-05	0,00316	0,022513
	3,62	0,0050	1,96344E-05	7,11419E-05	0,00274	0,025964
	3,62	0,0050	1,96344E-05	7,11419E-05	0,00236	0,030145
	3,62	0,0050	1,96344E-05	7,11419E-05	0,00205	0,034703
external gas cooler	1,25	0,0058	2,642E-05	3,31351E-05	0,00187	0,017719
	1,25	0,0058	2,642E-05	3,31351E-05	0,00177	0,01872
	1,25	0,0058	2,642E-05	3,31351E-05	0,00169	0,019607
	1,25	0,0058	2,642E-05	3,31351E-05	0,00161	0,020581
	1,25	0,0058	2,642E-05	3,31351E-05	0,00156	0,02124
	1,25	0,0058	2,642E-05	3,31351E-05	0,00149	0,022238
expansion	0,09	0,0009	6,36154E-07	5,83141E-08	0,00147	3,97E-05
	0,09	0,0009	6,36154E-07	5,83141E-08	0,0015	3,89E-05
	0,09	0,0009	6,36154E-07	5,83141E-08	0,00155	3,76E-05
	0,09	0,0009	6,36154E-07	5,83141E-08	0,00186	3,14E-05
	0,09	0,0009	6,36154E-07	5,83141E-08	0,00236	2,47E-05
	0,09	0,0009	6,36154E-07	5,83141E-08	0,003	1,94E-05
tube high pressure	4,22	0,004350	1,48613E-05	6,27145E-05	0,0025	0,025086
tube low pressure	1,35	0,004350	1,48613E-05	2,00627E-05	0,004	0,005016
sum				0,000993487		0,355692

Table C.1 Refrigerant charge calculation

Appendix D: Original data from each experiment

The files are delivered with this thesis.

Appendix E: Modified and calculated data from each experiment

The files is delivered with this thesis.