

Kai Rune Lysbakken

Salting of Winter Roads

The Quantity of Salt on Road Surfaces after Application

Thesis for the degree of Philosophiae Doctor

Trondheim, August 2013

Norwegian University of Science and Technology
Faculty of Engineering Science and Technology
Department of Civil and Transport Engineering



NTNU – Trondheim
Norwegian University of
Science and Technology

NTNU

Norwegian University of Science and Technology

Thesis for the degree of Philosophiae Doctor

Faculty of Engineering Science and Technology
Department of Civil and Transport Engineering

© Kai Rune Lysbakken

ISBN 978-82-471-4550-0 (printed ver.)
ISBN 978-82-471-4551-7 (electronic ver.)
ISSN 1503-8181

Doctoral theses at NTNU, 2013:217

Printed by NTNU-trykk

ABSTRACT

Chemical application forms an important part of winter maintenance activities with the aim of upholding a high level of accessibility, regularity and safety of roads during winter time. The quantity of chemical on the road surface is crucial for the road surface conditions and will determine whether ice formation or snow compaction occurs. For decision makers it is therefore essential to ensure that there is a sufficient quantity of salt on the road surface according to the prevailing road and weather conditions. At the same time adverse environmental effects are well documented. Therefore, there is a need to use as little chemical as possible while still ensuring safe driving conditions. An optimized chemical usage requires that decision-makers have sufficient knowledge of the quantity of chemicals on the road surface at any time.

The scope of this study is to acquire knowledge of how the quantity of salt on the road surface changes after application under different conditions and thereby to learn about the durability of salting actions. Further, it is to identify the physical processes that control the changes in the quantity of salt after application and important factors behind these processes.

To study the questions addressed, field observations have been conducted. The field observations have been carried out on an ordinary road, open for traffic. The method has been to document the salt quantity before and after application. During the observations the salt and water quantity on the road surface was measured along with weather parameters, traffic data and data from the maintenance trucks. The salt quantity has been measured with the Sobo 20 instrument.

Sobo 20 is a portable instrument that allows measurements on several locations and in different positions in the cross profile of the road. The unique feature of Sobo 20 is that the instrument itself adds measuring fluid onto the road surface during the measuring procedure and thereby is able to calculate the salt quantity on the road surface in terms of quantity per unit area. To document the accuracy and limitations of the instrument, some tests have been conducted. The conclusion is that Sobo 20 accurately measures the quantity of salt as brine, on both smooth surfaces and asphalt pavements. However, it only detects between 5 and 6% of dry salt particles. Re-crystallized salt, made of finer grains, is detected at 58 % on smooth surface and 49% on asphalt pavement. When using the Sobo 20 for the measurement of dry or pre-wetted salt, the displayed value must be interpreted only as the quantity of dissolved salt on the road surface, and not the total salt quantity.

The field observations clearly show that there are large spatial variations in salt quantity after application due to the effect of traffic. There is large variation in the cross-section profile of the road. Not surprisingly, higher quantities are measured at road edges, between wheel tracks and at the centre of the road compared to inside wheel tracks. This is explained by salt gathering because of the traffic effect and the fact that there are higher quantities of water in these areas that allow more salt to dissolve. For the further examination of the changes in salt quantity as a function of time or traffic, it has been chosen to focus mainly on the salt quantity in wheel tracks.

The results show significant differences in the quantity of salt after application between the various observations, and some of these differences can clearly be explained by the quantity of water on the road surface. The quantity of water on the road surface determines the

quantity of salt after application. Wet road surfaces both dissolve and loose salt more rapidly than moist road surfaces. The data also show that there is a surprisingly rapid loss of salt, especially on wet road surfaces. After 200 to 400 passing vehicles, the quantity of salt equals that before application. Further, it is also clear that the measured salt quantity after application cannot be described by a simple linear or exponential decrease in salt quantity. Shortly after application there is an increase in the measured salt quantity, thereafter followed by a decrease in salt quantity.

Based on the results from the field observations, three different physical processes that control the changes in salt quantity after application are identified. They are initial loss, dissolution of salt, and loss of salt. The initial loss of salt occurs at the time of spreading. The dissolution process is the process whereby solid salt dissolves in the water or brine present on the road surface. The process is mainly time-dependent and is relevant when spreading dry or prewetted salt. The loss of salt after application is time and traffic dependent and three distinct mechanisms have been identified that remove salt from the road surface: blow-off, spray-off and run-off. Blow-off is described as solid salt that is blown off the road surface by traffic, spray-off is dissolved salt sprayed off the road surface by traffic, while run-off is drainage of dissolved salt from the road surface.

From the identification of the processes that control the salt quantity after application, a physically based model for the salt quantity is proposed. The model is certainly based on several simplifications and assumptions. The most important are that the dissolution and loss processes are independent, that there are linear relationship between time and traffic and that there is no run-off. The model is adapted to the empirical data from the field observations. The analyses show that the model produces a satisfactory fit with the data from the field observations, and it therefore seems reasonable to conclude that these processes and the model developed can explain the changes in salt quantity after application. Although the model seems to fit the data for salt measurements, it is realized that it makes some assumptions and simplifications that may be incorrect. To achieve a more precise model, further development is needed, for example the introduction of a function describing run-off and the incorporation of the effect of different vehicle types. In addition to a more complex model, data of higher quality are needed.

The main results of this study are in the identification of the physical processes and in the principle of building a physically based model for the salt quantity on road surfaces. The attempt to understand the physical processes is essential to achieve a more thorough understanding of the phenomena of salt quantity on road surfaces after application.

ACKNOWLEDGEMENTS

My work on the project presented in this thesis began as early as in 2003. I was then allowed by my employer, the Norwegian Public Roads Administration (NPRA), to start my PhD studies at the Norwegian University of Science and Technology (NTNU). During these years I was permitted to work part-time on my PhD project along with other tasks at the research and development department at NPRA. Working part-time on my PhD gave me the opportunity to participate in many interesting projects at NPRA and to be closer to the practical field of winter maintenance. At the same time, part-time work on my PhD project has also made it challenging to prioritize the longer-term work involved in this. I must therefore confess that my occasional lack of self-discipline is the main reason why it has taken ten long years to finish this work. Therefore, I must firstly express my thanks to my employer and especially Svein Ryan and Øystein Larsen for their support and belief that I would be able to finish this project.

My interest in winter maintenance of roads started with a lecture during my studies for the Master's degree at NTNU. Torgeir Vaa held an inspiring lecture about the research activities related to developing the method of hot water pre-wetted sanding. Torgeir Vaa, at that time senior researcher at SINTEF, and Roar Støtterud, NPRA, gave me the opportunity and support to do my Master's project on the topic of the hot water pre-wetted sanding method. Roar Støtterud is sadly no longer with us. He generously introduced me to the NPRA and the winter maintenance research community, and he gave me the chance to work within this field at the NPRA. For that I am very grateful. Roar will be remembered for his important efforts in developing winter maintenance in Norway and the inspiration he gave many of us working within this field.

I express my thanks to Alex Klein-Paste, now Assistant Professor at NTNU, for many fruitful discussions during my PhD project. These discussions inspired me to continue the work. Thanks also to my colleagues Johan Wählin, Bård Nonstad and Åge Sivertsen for their useful comments and discussions. Laboratory technicians Tore Menne, Stein Hoseth and Lisbeth Johansen have provided very useful help when it was needed. Thanks to Anne Lalagüe for the collaboration on testing Sobo 20 and writing Paper V. Thanks also to Professor Inge Hoff who has been my supervisor at NTNU since 2008.

The person who deserves my gratitude more than any other is Harald Norem. Harald was a professor at NTNU and my supervisor there when I started my PhD and until 2008. Since leaving NTNU and starting at NPRA he still continued to be my supervisor, even if he formally not was my supervisor. Harald has provided me with all the help I have needed. His office door has always been open and he has always been willing and able to discuss my work. As an example of his goodwill, when I have been late for a deadline to submit a paper, Harald has found the time during his summer break to read my work and offer me guidance. His patience with me has been remarkable during these years, and not least, his academic skills have helped and inspired me.

Last but not least, thanks to my wife Ellen. Thank you for helping me by proofreading papers and this thesis. Thank you for your patience and understanding through these years and for never losing faith that I could finish this project.

Kai Rune Lysbakken

TABLE OF CONTENTS

ABSTRACT.....	III
ACKNOWLEDGEMENTS.....	V
TABLE OF CONTENTS.....	VII
LIST OF SYMBOLS	IX
1. INTRODUCTION.....	1
1.1. SCOPE AND MOTIVATION	1
1.2. THE STRUCTURE OF THE THESIS.....	2
2. WINTER MAINTENANCE OF ROADS.....	3
2.1. THE EFFECT OF WINTER ON DRIVING CONDITIONS AND THE IMPORTANCE OF WINTER MAINTENANCE	3
2.2. WEATHER AND ROAD SURFACE CONDITIONS AND WINTER MAINTENANCE ACTIONS	4
2.3. DIFFERENT METHODS FOR SNOW AND ICE CONTROL.....	4
2.4. SELECTING METHOD FOR SNOW AND ICE CONTROL	5
2.5. CHEMICAL METHODS AS AN INTEGRATED PART OF A WINTER MAINTENANCE STRATEGY	7
3. CHEMICAL METHODS FOR SNOW AND ICE CONTROL.....	9
3.1. THE MECHANISMS OF MECHANICAL METHODS FOR SNOW AND ICE CONTROL	9
3.2. ANTI-ICING.....	9
3.2.1. Freezing point depression of water	10
3.2.2. Reducing the mechanical strength of ice	12
3.3. ANTI-COMPACTION	14
3.3.1. The mechanism of anti-compaction	14
3.3.2. The practical aspects of anti-compaction	15
3.4. DE-ICING	15
3.4.1. Melting of ice.....	15
3.4.2. Penetration and undercutting	16
3.5. DIFFERENT CHEMICALS FOR SNOW AND ICE CONTROL.....	17
4. A REVIEW OF THE LITERATURE ON SALT QUANTITY AFTER APPLICATION.....	19
5. FIELD OBSERVATIONS.....	23
5.1. FIELD OBSERVATIONS PROCEDURE.....	23
5.1.1. The observation point.....	23
5.1.2. Carrying out observations and measuring procedures.....	26
5.1.3. Type of data collected.....	27
5.2. MEASURING SALT QUANTITY ON ROAD SURFACES	28
5.3. MEASURING WATER QUANTITY ON ROAD SURFACES	28
5.4. OTHER MEASUREMENTS	30
5.4.1. Maintenance data	30
5.4.2. Traffic data	30
5.4.3. Weather data	31
5.4.4. Photographic documentation and description of road surface condition.....	32
6. MEASURING SALT ON ROAD SURFACES.....	33
6.1. SALT CONCENTRATION VERSUS SALT QUANTITY PER UNIT AREA	33
6.2. POSSIBLE MEASURING PRINCIPLES AND INSTRUMENTS.....	34
6.2.1. Optical.....	34
6.2.2. Thermodynamic	34
6.2.3. Electrical	34
6.2.4. Other possible measuring principles	35
6.2.5. Road surface sensors	36
6.2.6. On vehicle systems.....	36
6.2.7. A brief discussion of challenges related to measuring salt on road surfaces	36

6.3. SOBO 20	37
6.3.1. <i>Description of the instrument</i>	38
6.3.2. <i>Strengths and limitations</i>	39
6.4. TEST OF SOBO 20	39
6.4.1. <i>Experimental procedures</i>	40
6.4.2. <i>Results</i>	42
6.4.3. <i>Conclusion</i>	46
7. RESULTS FROM FIELD OBSERVATIONS.....	47
7.1. AN OVERVIEW OF THE OBSERVATIONS AND THE AVAILABLE DATA	47
7.1.1. <i>Example of data from an observation period in 2005/2006</i>	48
7.1.2. <i>Example of data from an observation period in 2006/2007</i>	51
7.1.3. <i>The use of the data in the papers</i>	54
7.2. SALT ON ROAD SURFACE AFTER APPLICATION	54
7.2.1. <i>The spatial distribution of salt</i>	54
7.2.2. <i>The salt quantity as a function of time or traffic</i>	59
8. PROCESSES THAT CONTROL THE QUANTITY OF SALT ON ROAD SURFACES AFTER APPLICATION.....	61
8.1. THE INITIAL LOSS	62
8.2. THE DISSOLUTION PROCESS	62
8.2.1. <i>The solubility</i>	63
8.2.2. <i>The dissolution rate</i>	63
8.2.3. <i>Describing the quantity of dissolved salt on the road surface</i>	64
8.3. THE LOSS OF SALT AFTER APPLICATION	65
8.3.1. <i>Blow-off</i>	66
8.3.2. <i>Spray-off</i>	66
8.3.3. <i>Run-off</i>	66
8.3.4. <i>Describing the quantity of the salt loss</i>	66
9. A PHYSICAL- BASED MODEL FOR SALT QUANTITY ON ROAD SURFACES AFTER APPLICATION.....	69
9.1. THE USE OF THE MODEL ON DATA FROM FIELD OBSERVATIONS	70
9.2. FURTHER DEVELOPMENT OF THE MODEL	72
9.2.1. <i>The loss processes</i>	72
9.2.2. <i>Data</i>	73
10. CONCLUSIONS	75
REFERENCES.....	77
PAPERS	83

LIST OF SYMBOLS

A	Exposed area of the vehicle (cross-section area)
a and b	Constants
C	Solution concentration
C*	Equilibrium saturation at the given temperature
C _D	Drag coefficient of the vehicle
ΔC	Degree of undersaturation
ΔT	Freezing point depression
i	The van't Hoff factor
k	Constant, Coefficient that governs the rate of salt decay
K _D	Dissolution mass transfer coefficient
k _D	Salt dissolution factor found from regression analysis
K _f	The cryoscopic constant
K _L	Salt loss factor describing the loss due to a single vehicle
k _L	Salt loss factor found from regression analysis
K _{RO}	Constant
m	The molality of the solution
m	Describing the relationship between time and traffic
m _{water}	quantity of water in g/m ²
PC _{eqacc}	Accumulated private car equivalents
Q	Run-off per time unit
RS	Residual salt
S	Salt used (spread salt)
S _A	Available salt on the road surface after spreading
S _D	Theoretical quantity of dissolved salt (with no loss)
S _{IL}	Initial salt loss during spreading
S _R	Residual salt (at time of spreading)
S _S	Quantity of salt spread
S _T	Total quantity of salt on the road surface
T	Time after salting
Tr	Accumulated traffic
v	Vehicle speed

Kai Rune Lysbakken

W	Mean water film thickness , Quantity of water on the road surface
W_C	Critical quantity of water, threshold value for water quantity when run-off occurs
ρ	Density of the air

1. INTRODUCTION

Road transport is of great importance for the mobility of people and for the transport of goods. Modern society has therefore become dependent on a road network that is accessible, efficient and safe throughout the seasons. In areas with severe winter weather, snow and ice can have a serious impact on driving conditions. In these areas the quality of winter maintenance of roads is critical for achieving a functional and safe system for road transport during wintertime.

Winter maintenance of roads encompasses different activities. The most important are related to friction control and the removal of snow and ice from the road surface. There are different methods for snow and ice control, and chemical application is one of the methods used to improve winter driving conditions. The topic of this thesis relates to the use of chemical methods for snow and ice control, often referred to as *salting*.

1.1. Scope and motivation

There are several factors that determine the success of chemical applications on winter roads. Among the most critical factors are considered to be the timing and rate of the chemical application. The quantity of chemical on the road surface is crucial for the road surface conditions and will determine whether ice formation or snow compaction occurs. For decision makers it is therefore essential to ensure that there is a sufficient amount of salt on the road surface according to the prevailing road and weather conditions. At the same time it is well known that the chemicals can have negative side effects, and depending on the level of use, chemicals can have serious adverse environmental effects. These include damage to roadside vegetation, surface water and aquifers. Chemicals can also have a negative effect on materials used in vehicles, road construction or road equipment. In addition, the cost of the chemical usage itself can be substantial. Therefore, there is a need to optimize the use of chemical methods by using as little chemical as possible while ensuring safe driving conditions. An optimized chemical usage requires sufficient knowledge of the durability of the salting actions. Obtaining an optimal timing and application rate requires that the decision maker should know the quantity of salt present on the road surface.

The scope of this thesis is to acquire knowledge of how the quantity of salt on the road surface changes after application under different conditions and thereby to learn about the durability of salting actions. Further, it is to identify the physical processes that control the changes in the quantity of salt after application and important factors behind these processes. An important part of this work is also to establish a terminology that can describe these processes.

Knowledge of the processes that control the quantity of salt after application is useful, not only in relation to the decision-making process. In research and development activities regarding salting, an understanding of the physical processes that determine the quantity of salt on road surfaces can be useful to obtain a fundamental understanding of the research phenomena, to establish proper research problems and to design proper experiments. Examples of such research and development activities are the testing of different spreading methods, alternative chemicals or the testing of additives to chemicals.

1.2. The structure of the thesis

This thesis consists of ten chapters and five papers in total. The main contributions and scientific work are presented in the papers. The chapters can be said to consist partly of extracts from the material presented in the papers and partly of material that is not presented in the paper. The aim has been for the chapters to stand alone so that they can be read in their entirety without constantly having to refer to the papers. The structure and content of the chapters are presented in Table 1.1, and the papers that are a part of the thesis are presented in Table 1.2

Table 1.1 The structure and content of the thesis.

Chapter no.	Topic description and relation to papers
Chapters 2 and 3:	An introduction to winter maintenance and chemical application in general.
Chapter 4	A review of the literature on the topic of salt quantity on road surfaces after application
Chapter 5:	A description of the field observations, the data collection and measurements. This is supplementary to the description given in the papers.
Chapter 6:	Measuring salt on road surfaces. Different possible measuring principles and instruments are discussed. An extract from the discussion in Paper I and the results from tests of Sobo 20 instrument in Paper V are presented.
Chapter 7:	Results from the field observations. Overview of results and the data obtained from field tests. Some data and analyses that are not present in the papers are shown here.
Chapter 8	Presentation and discussion of the processes that control the quantity of salt on road surfaces after application. A summary of the discussion in Papers II and III.
Chapter 9:	Presentation and discussion of a physically based model. Summary of the presentation in Paper III. A discussion of further development of the model.
Chapter 10:	Conclusions.

Table 1.2 The papers that are a part of the thesis.

Paper no.	Author, title, place and date of publishing
Paper I:	Lysbakken, Kai Rune: <i>Measuring salt on road surfaces -A discussion of salt concentration versus salt amount.</i> Presented at the 14th SIRWEC Conference in Prague, 14-16 May 2008.
Paper II	Lysbakken, Kai Rune and Norem, Harald: <i>The Amount of Salt on Road Surfaces after Salt Application – a Discussion of Mechanisms and Parameters.</i> Presented at Seventh International Symposium on Snow Removal and Ice Control Technology in 2008. Transportation Research Circular E-C126.
Paper III:	Lysbakken, Kai Rune and Norem, Harald: <i>Processes that Control Development of Salt Quantity on Road Surfaces after Salt Application.</i> The Transportation Research Board's (TRB) 89th Annual Meeting in 2010. Journal of Transportation Research Board No. 2258 in 2011.
Paper IV:	Lysbakken, Kai Rune: <i>Field Observations on the Quantity of Salt on Road Surfaces after Salt Application.</i> Presented at the Transportation Research Board 89th Annual Meeting in 2010.
Paper V:	Lysbakken, Kai Rune and Lalagüe, Anne: <i>Accuracy of SOBO-20 in the measurement of salt on winter pavements.</i> Presented at the Transportation Research Board's 92nd Annual Meeting in 2013, submitted and accepted for publication in the Journal of the Transportation Research Board.

2. WINTER MAINTENANCE OF ROADS

There are several terms that describe winter maintenance activities. *Snow and ice control* is a general term which can be understood to embrace the totality of winter maintenance activities. *Snow and ice removal* is also a term used for winter maintenance and is a narrower term defining activities to remove ice and snow from the road surface. *Friction control* is activities aimed at maintaining or increasing the level of friction between the road surface and the vehicle tires.

The most important aim of winter maintenance is to ensure that the road surface offers vehicles sufficient friction and evenness for safe driving. Snow and ice removal from the road surface and friction control are therefore the most labor-intensive and important activities related to the winter maintenance of roads. One method of friction control and facilitating the removal of snow and ice is the application of chemicals on the road surfaces.

Winter maintenance can traditionally be described as a practical discipline. Knowledge and expertise in winter maintenance often exist in the form of practical and tacit knowledge amongst winter maintenance personnel. The development of knowledge and methods has often come about through practical trials and hands-on experience. Thus, despite substantial development and highly skilled personnel, there is often a lack of documentation and concrete explanation.

2.1. The effect of winter on driving conditions and the importance of winter maintenance

Ice and snow deposition on the road surface will influence its ability to provide sufficient friction and evenness for vehicles. Falling and drifting snow can cause poor visibility. Examples of extreme driving conditions include the danger of snow avalanches across the road or high winds capable of blowing a vehicle off the road (Norem and Thordarson, 2001). In addition there are other problems, for example poor visibility of road signs due to snow deposition and when fallen snow and storage of snow after snow-clearing result in poor visibility at intersections and so on.

Investigations of accident rates during wintertime show that snow and ice have a substantial effect on traffic safety. Swedish studies have shown that the accident rate is in the range of 3 to 30 times higher on snow and ice-covered roads than on bare, dry roads (Wallman, 2002), depending on the type of road surface conditions and the rate of traffic on snow and ice conditions. Based on Swedish data material, Norem (2009) found that depending on maintenance class (winter maintenance requirements) and climatic conditions, the accident rates on ice or snow-covered roads could be up to 16 times higher than on bare roads. Norwegian studies have shown that the accident risk is 1.5 to 4.4 times higher on snow or ice-covered roads than on dry roads, depending on the type of snowy or icy conditions (Vaa, 1995).

Winter maintenance of roads is therefore essential to ensure the mobility of people and transport of goods during wintertime. Thus, in areas with a harsh winter climate substantial funding is spent on winter maintenance. In some areas, it is estimated that up to 50% of the maintenance budget is spent on winter maintenance (COST, 2008).

2.2. Weather and road surface conditions and winter maintenance actions

The need for winter maintenance actions is essentially determined by the weather. Different weather processes and traffic interact and thereby determine the road surface conditions. Klein-Paste (2008a) identified the physical processes that affect the condition of an airport runway surface, and most of these processes are also relevant for the condition of a road surface. Klein-Paste (2008a) divided the processes into whether they are related to: 1) weather, 2) traffic or 3) winter maintenance actions.

Winter maintenance actions attempt to control or improve the road surface conditions and thereby the driving conditions in spite of the influence of the weather or traffic-related processes. There are a wide range of weather and traffic processes that trigger a need for winter maintenance actions. The table below lists the weather and traffic-related processes and the type of winter maintenance required:

Table 2.1 The different processes triggering the need for winter maintenance actions.

Process	Winter maintenance activities required
<i>Weather related:</i>	
Falling snow	Snow removal
Drifting snow	Snow removal
Temperature decreasing with wet road surface	Friction control
Dew deposition on cold pavement	Friction control
Rain on snow or ice-covered surface	Friction control (and ice removal)
Super-cooled rain or rain on cold pavement	Friction control
<i>Traffic related:</i>	
Compaction of snow on the road surface	Snow or ice removal
Polishing of snow-covered road surface	Friction control
Rutting of ice-covered road due to traffic	Ice removal

There are a range of processes or situations that require actions for snow or ice removal or friction control. This demands methods and techniques that are robust and can be used in different situations. In addition to the fact that several different processes can trigger a need for winter maintenance actions, the winter often brings a great diversity of weather both in time and in space. The decision-making process of winter maintenance is therefore a challenging task. It requires information about prevailing surface and weather conditions and expected weather and traffic conditions.

2.3. Different methods for snow and ice control

For carrying out the winter maintenance of roads, a variety of different methods and techniques have been developed through the years. According to Minsk (1998) the methods used for snow and ice control can be divided into three categories:

1. Mechanical methods
2. Chemical methods
3. Thermal methods

Thermal methods mean that heat of some sort is applied to the road surface for snow and ice removal or to prevent the freezing of water. Thermal methods include very different techniques, e.g. electric heater cables embedded into the pavement and hydronic systems with different heat sources, e.g. geo-thermal. The use of thermal methods is not widespread and is mostly used on sidewalks and other areas for walking and cycling. Some countries such as Japan, Iceland and the USA have also been testing different types of thermal methods for road surface purposes (Wang et al., 2010).

Chemical methods involve using a chemical as freezing point depressant for both friction control and for snow and ice removal. Normally, chemical methods are not used alone for ice and snow removal but along with mechanical methods. The term *chemical methods* is probably better known as *salting*. Salt is often understood to be the chemical sodium chloride, but in principle several chemicals can be used for snow and ice control. The term *chemical methods* can be useful to avoid the application of chemicals on winter roads being solely understood as the use of sodium chloride.

Mechanical methods for snow and ice control involve the use of snow plows and graders for snow and ice removal, and the use of abrasives for friction control. (Minsk, 1998)

2.4. Selecting method for snow and ice control

There are several factors that determine the effect of the different methods for snow and ice control and thereby which method is appropriate for different types of road or climatic conditions. The different methods have both advantages and limitations. The main technical factors influencing the effectiveness and suitability of different methods are climate and traffic (volume and type). In addition to the technical limitations of the different methods, there are other parameters that may be considered when choosing methods for snow and ice control on a certain road network. This could be a high accident rate or poor accessibility of a road section caused by e.g. poor road geometry, or the importance of the road.

The high quantity of energy required for the melting of ice or snow makes thermal methods economically costly and can be unrealistic in areas with harsh winter conditions with low temperatures and a moderate to large quantity of snow. The use of thermal methods is hence not further discussed.

The mechanical methods of snow and ice control have some limitations. Snow removal using only plowing or graders is in some cases insufficient. High traffic volumes will easily compact falling or drifting snow into a hard layer on the road surface. Further, the compaction from traffic will change the snow layer into ice and together with a polishing effect from the vehicle tires, result in low friction for vehicles. This is especially the case at temperatures close to melting point (0°C). After some time traffic will also create wheel tracks and an uneven road surface. Removing this ice or snow layer using graders on roads with high traffic volumes is not feasible. The icy road surface condition can endure for a long time resulting in difficult driving conditions for long periods. In case of increasing temperatures and/or rain the ice layer will result in very slippery road surface conditions. Abrasive for friction control also has a limited effect. In some conditions traffic will easily blow the sand particles off the road and after a short time result in the tire-pavement friction being almost the same as before sand application. It is typically in situations with a thin ice layer, frost or wet ice that sand application has a very brief effect on the friction. The relatively newly developed method of freeze-bonded sand by pre-wetting with hot water (Vaa, 2004) also has its limitations. This method is advantageous in conditions with a compact ice/snow layer in cold and stable weather conditions. On thin ice or frost the method has limited effect, and on wet ice the effect of the method is assumed to be the same as the effect of ordinary dry sand application.

The limitations of chemical methods are related to low temperatures, high precipitation rates of snow and also limited effect at low traffic volumes. It is known that the effect of chemical application decreases with decreasing temperatures because of limitations in freezing point depression and melting capacity. Substantial quantities of precipitation of snow will result in a

disproportionate use (rate) of chemicals. It is also commonly assumed that a certain volume of traffic is required, at least in some conditions, for the chemical methods to be effective. This is related to distribution and dissolution of chemical on the road surface. To the author's knowledge this fact is not well documented with regard to how much traffic is needed.

From the discussion regarding the benefits and limitations of mechanical and chemical methods it is clear that these two methods are not completely overlapping in terms of area or range of application. Mechanical methods are favorable on roads in areas with a cold and stable climate and on relatively low traffic volumes. On the other hand, chemical methods are most effective in areas with a relatively mild climate and roads with higher traffic volumes. This can be visualized as shown in Figure 2.1. The principles behind this figure are taken from Engen (2006) and Norem (2009).

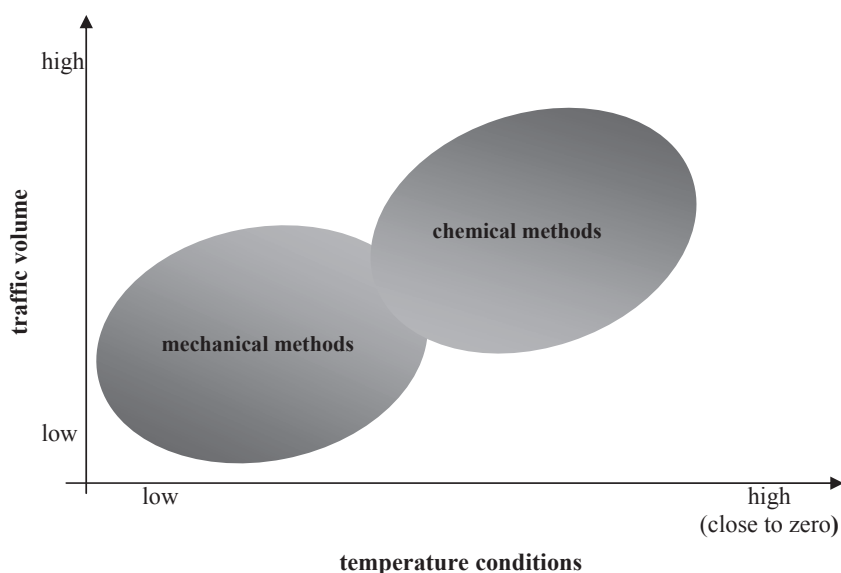

Figure 2.1 Choice of winter maintenance method based on traffic and climatic conditions.

Norem (2009) investigated the relationship between climatic factors and the effect of chemical versus mechanical methods on traffic safety. Based on this work it seems correct to state that mechanical methods appear favorable in areas with cold and harsh winter conditions, while chemical methods appear favorable in areas with milder winter conditions.

2.5. Chemical methods as an integrated part of a winter maintenance strategy

The different techniques and methods for snow and ice control cannot be seen as isolated tools, or just as different spreading materials that can be selected freely. Rather, the choice of methods for a road network should be seen as part of a total strategy for winter maintenance.

This is of great importance for the use of chemical methods as it sets stringent demands on other parts of the winter maintenance system. For successful use of mechanical methods three important elements can be emphasized:

1. A proactive approach
2. Skilled and specially trained personnel
3. As much mechanical removal of snow and ice as possible

Successful use implies a low use of chemicals and satisfactory driving conditions with as little slush and snow on the road surface as possible.

Firstly, the use of chemicals requires a proactive approach. A proactive approach means that chemical application takes place before ice formation (anti-icing) or before snowy weather (anti-compaction). The proactive nature of chemical application is at the same time the most important benefit of a strategy using chemicals, since it is possible to prevent poor driving conditions and not only to take action after poor driving conditions have occurred. To be proactive requires proper information for decision making and sufficient resources, including equipment and crew. Secondly, the use of chemicals requires highly skilled maintenance personnel. They must have a high level of knowledge regarding effect, limitations and other aspects when using chemicals. Thirdly, successful use of chemical methods for snow removal purposes means that chemical application be followed by plowing (mechanical methods) with appropriate equipment. This requires plows adapted for removal of slush and sufficient resources for frequent plowing. In that respect, chemical application in winter maintenance is a distinct strategy that requires a winter maintenance system adapted for chemical methods.

Kai Rune Lysbakken

3. CHEMICAL METHODS FOR SNOW AND ICE CONTROL

Chemical application is one method for snow and ice control of winter roads but as mentioned earlier, chemical methods are not used alone, but along with mechanical methods, and as such must be seen as only one part of a total strategy for snow and ice control.

3.1. The mechanisms of mechanical methods for snow and ice control

In principal, three different purposes can be defined for using chemical application for snow and ice control:

1. To prevent the formation of ice on the road surface
2. To facilitate the mechanical removal of snow during snowy weather
3. To melt/remove ice or compacted snow on the road surface

Each of these purposes can be related to some distinct physical mechanism or property of the chemicals. The table below shows the three purposes, the related physical mechanisms and the relevant term.

Table 3.1 The different purposes of chemical application on winter roads.

Purpose	Mechanism	Term
1. Prevent the formation of ice on the road surface.	The chemical acts as a freezing-point depressant of water.	<i>anti-icing</i>
2. Facilitate the mechanical removal of snow.	The chemical prevents bonding between snow crystals and between snow crystals and pavement.	<i>anti-compaction</i>
3. Melt and facilitate the mechanical removal of ice or compacted snow.	The chemical melts and penetrates the ice/snow layer and breaks the ice/snow-pavement bond, and facilitates any mechanical removal.	<i>de-icing</i>

Purpose number 1 is known as *anti-icing* and number 3 as *de-icing*. There is no well-established term describing the purpose of chemical applications to ease the removal of snow during snowy weather, but a suggested term for this is *anti-compaction*. These three purposes are closely linked to the physical effect of water-soluble chemicals on water and ice, the freezing point depression of water and the melting of ice.

3.2. Anti-icing

Using a chemical as anti-icing means applying chemical to the road surface to prevent the formation of ice by preventing water from freezing. A typical situation where chemicals are used as anti-icing is when the road surface is wet, either from precipitation or melting water, and road temperature is dropping. Before the deposition of dew on a cold road surface, chemicals can be applied to prevent frost or rime. Chemical application can also take place before freezing rain or super-cooled rain to try to prevent ice formation on the road surface. When using chemical application as anti-icing, the effect of freezing point depression of water is utilized.

The advantage of anti-icing is clearly that winter maintenance actions can be carried out before ice formation and before the road surface becomes slippery. This possibility to perform pro-active winter maintenance is what clearly distinguishes chemical methods from mechanical methods.

3.2.1. Freezing point depression of water

The freezing point depression of a liquid solvent (e.g. water) in the presence of a solute (e.g. sodium chloride) is well known and described in the literature (Atkins and Paula, 2010). It can be explained by thermodynamics and so-called entropy effects (Kim and Yethiraj, 2008).

The freezing point depression of a solution is a so-called colligative property. That means that the freezing point depression in principle depends only on the number of solute particles present and not on their identity. Thus, the freezing point depression of water is not dependent on the type of chemical dissolved into the water, but only on the number of dissolved molecules or ions. Lowering of vapor pressure, elevation of boiling point and osmotic pressure are other colligative properties. The freezing point depression can be expressed by the following equation (Moore et al., 2011 and Helbæk, 1999):

$$\Delta T_f = K_f \cdot m_{\text{solute}} \quad (3.1)$$

Where:

ΔT = Freezing point depression [$^{\circ}$ C or K]

K_f = The cryoscopic constant [K·kg/mol]

m = The molality of the solution [mol solute/kg solvent]

Molality, m , is the concentration of solute molecules given in mol of solute per kg solvent. Equation 3.1 shows that the freezing point depression, ΔT , of the solvent (e.g. water) is in linear proportion to the concentration of solute molecules (e.g. sodium chloride). The proportionality constant describing this relationship is called the cryoscopic constant, K_f . The theory that freezing point depression is a colligative property implies that this constant is related only to the type of solvent, not to the type of solute. For water K_f is 1.86 K kg/mol.

When electrolytes such as sodium chloride dissolve in water, they dissociate. The dissociation of sodium chloride when dissolved in water is shown in equation 3.2.

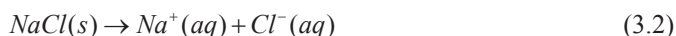

Due to their dissociation, electrolytes contribute to more particles than do non-electrolytes. Therefore electrolytes have a greater effect on colligative properties than non-electrolytes. For solution of electrolytes the freezing point depression can be expressed as follows (Moore et al., 2011):

$$\Delta T_f = i \cdot K_f \cdot m_{\text{solute}} \quad (3.3)$$

Where:

i = The van't Hoff factor

The van't Hoff factor gives the number of particles per molecule of solute. For sodium chloride the theoretical van't Hoff factor is 2, because one molecule sodium chloride produces two ions.

The actual freezing point depression deviates from the ideal behavior expressed in equation 3.1 and 3.3. Fullerton et al. (1994) states that this deviation is due to different types of molecular interaction. The deviation will differ for different types of solute and will also

depend on the concentration. As the molar concentration of solute rises, the deviation from the ideal behavior also rises. The actual freezing point depression therefore needs to be found experimentally. The calculated freezing point according to equation 3.3 and the measured freezing point of a solution of water and sodium chloride are shown in Figure 3.1. Data for measured freezing point are taken from Bodnar (1993).

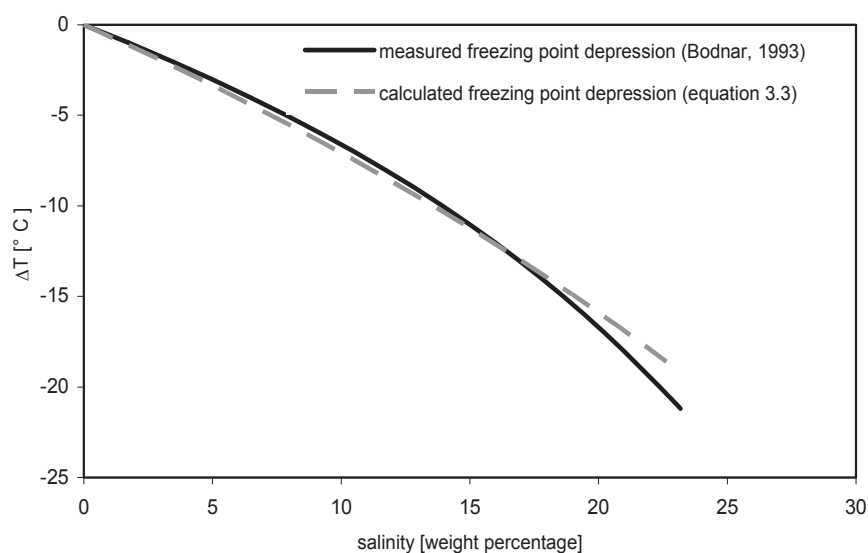

Figure 3.1 Calculated and measured freezing point depression of water with sodium chloride.

The figure shows the freezing point for the solution of water and sodium chloride as a function of the salinity given in weight percentage. That means that the concentration of solute molecules (sodium chloride) that is given in molality (mol solute per kg solvent) in equation 3.3 is converted into weight percentage (kg solute per kg solution). This explains why the graph for the freezing point is curved and not linear as it would have been if plotted as a function of molality.

In Figure 3.1 the curve describing the freezing point ends at a concentration of 23.3 weight percent. This limit is due to the solubility of sodium chloride. The solubility is defined as the maximum quantity of solute that can dissolve in a certain quantity of solvent at a specified temperature. Different chemicals have different solubility in water. In most cases solubility increases with temperature, but as Mullin (2001) states, there are a few well-known exceptions. The solubility of sodium chloride is one of them because there is only a slight increase with temperature. At 0° C the solubility is 26.3 weight percent and at -21.2° C the solubility is 23.3%. The freezing point will decrease with increasing salinity until the saturation point is reached. Additional sodium chloride added to the solution will not dissolve and therefore not result in a further decrease in the freezing point. Plotting both the freezing point curve and the solubility curve will result in a so-called phase diagram. Figure 3.2 shows the phase diagram for the solution of sodium chloride and water.

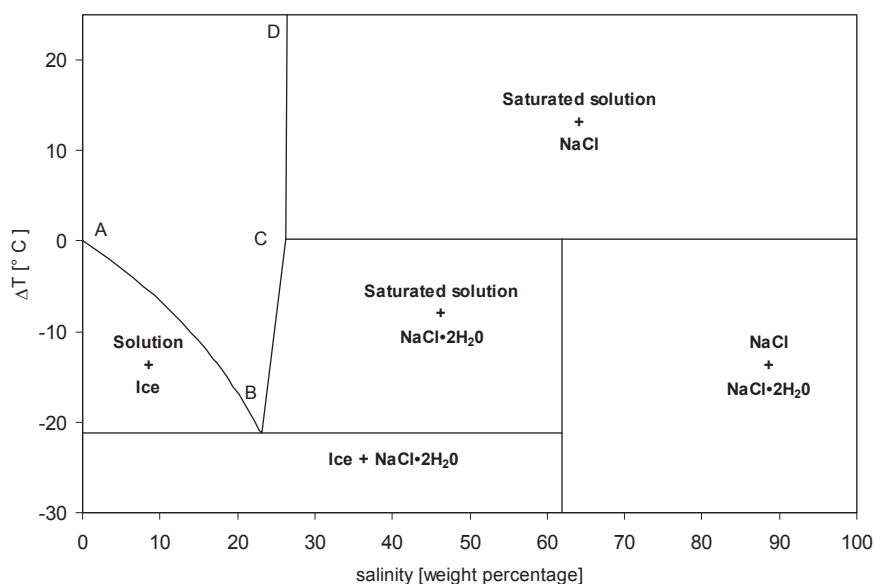

Figure 3.2 The phase diagram of a solution of water and sodium chloride.

In Figure 3.2 the line from point A to point B represents the freezing point curve, while the line BCD represents the solubility curve. As shown, as the salinity increases the freezing point decreases until it meets the solubility curve. Then the solution has reached saturation point, no more sodium chloride will be dissolved, and the maximum freezing point depression is therefore reached. The point where the freezing point curve and solubility curve meet, thereby giving the maximum freezing point depression, is called the eutectic point. For sodium chloride dissolved in water the eutectic point is -21.2°C at 23.2 weight percentage sodium chloride. The line BCD, which represents the solubility curve for sodium chloride, has a discontinuity at 0.10°C , shown as point C in Figure 3.2. Line BC is the solubility curve for dihydrate ($\text{NaCl}\cdot 2\text{H}_2\text{O}$), while line CD is the solubility curve for the anhydrous salt (NaCl). Point C represents the transition point (melting point), of the dihydrate. Below this temperature the anhydrous salt is unstable and above this temperature the dihydrate is unstable. (Kaufmann, 1960)

3.2.2. Reducing the mechanical strength of ice

Klein-Paste and Wåhlin (2011) states that freezing point depression alone does not always provide a sufficient explanation of anti-icing. On wet road surfaces it predicts a high quantity of chemicals to keep the road from becoming slippery. As pointed out by Klein-Paste and Wåhlin (2011) it is well known among maintenance engineers that a minimum of traffic is required for successful anti-icing actions. This indicates that the freezing point itself is not the only mechanism behind anti-icing. This is also supported by data from the field observations conducted in this study, see Figure 3.3.

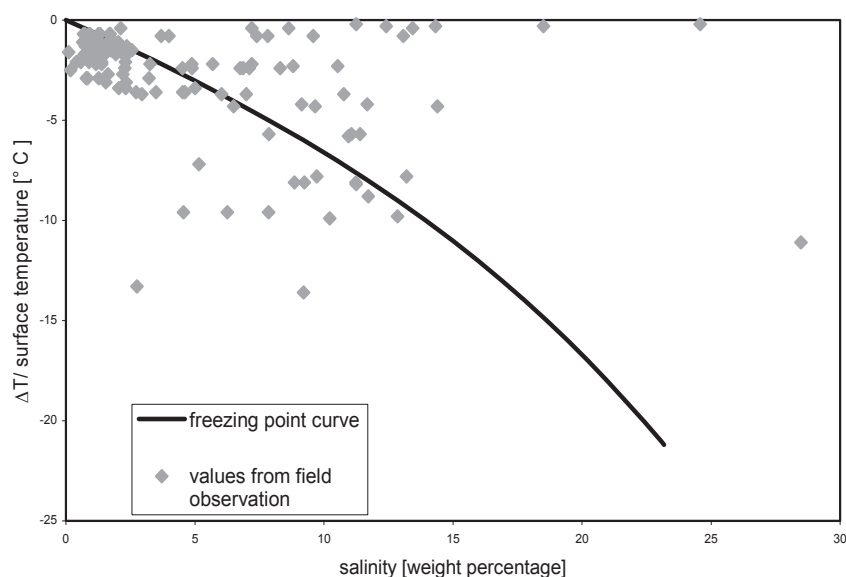

Figure 3.3 Measured concentration and temperature on road surface compared with the freezing point curve for sodium chloride and water.

Figure 3.3 shows the freezing point curve of a solution of sodium chloride and water and data from field observations (further details of the field observations in Chapter 5). The observed road surface temperature is plotted against the salinity (calculated from the measured water and salt quantity). It can be seen in the figure that several data points are below the freezing point curve and should therefore result in a slippery road surface. Slippery road surface was not detected during these observations. This indicates that the lowering of freezing point alone is not enough to explain the anti-icing of road.

When brine starts to freeze, pure water will start to freeze into ice since salt is not accepted in the ice lattice. The salinity of the remaining brine will increase and thereby require a further decrease in temperature to continue freezing. That means that during freezing there will always be a certain fraction of ice and a certain fraction of solution, until the eutectic temperature is reached, as shown in Figure 3.2. Klein-Paste and Wählin (2011) have found that the ratio between ice and solution determines the mechanical properties of ice. Through laboratory studies they have shown that the ice is too weak to withstand a certain load simulating traffic when the temperature and concentration result in an ice fraction less than 0.7. When the ice is too weak to withstand the simulated traffic, the ice will break and be removed by it. Even though some ice has been formed on the road surface it will not cause slippery roads.

This explains why some of the field observations did not result in slippery road surface even though the salinity of the water on the road surface and the road surface temperature indicated that freezing had occurred.

In summary, anti-icing of winter roads with chemicals can be explained by the lowering of freezing point of water and the weakening of mechanical strength of ice.

3.3. Anti-compaction

In winter road maintenance, chemical methods are also used in cases of snowy weather. Chemicals are spread before and during snowfall to ease the mechanical removal of snow by plows. Chemical applications prevent snow from compacting into a hard snow layer on the road surface, hence the term *anti-compaction*. To the author's knowledge there is no well-established term in this context for chemical application. The term anti-compaction can be discussed, but is proposed in order to establish one single term describing the purpose of chemical application before and during snowy weather. It is important to point out that the term compaction here does not describe the process of densification, but rather the bonding of snow grains.

3.3.1. The mechanism of anti-compaction

The exact mechanisms of anti-compaction are, to the author's knowledge, not well investigated and described in the literature. This is in contrast to anti-icing and the freezing point depression of water. The underlying mechanisms of the effect of sodium chloride or other chemicals used for winter maintenance on the mechanical properties of snow are not known or at least not well described in the literature. Even though the theoretical basis for anti-compaction is not well established, the practical experience and utilization is well known.

It is important to emphasize that the term "anti-compaction" here does not relate to the prevention of densification, but rather to the prevention of snow grains bonding. By preventing bonding between snow grains the mechanical strength of snow is reduced and thereby also the capability to form a hard compacted snow layer on the road surface. The bonding between snow grains is a phenomenon known as sintering (Colbeck, 1997).

As stated by Colbeck (1979) snow is a complicated material because it takes a variety of forms and is a thermodynamically unstable material which undergoes rapid changes if stressed, subjected to temperature gradient or wetted. The process which leads to changes in deposited snow crystals is called metamorphosis (Vigneault and Gameda, 1994). Metamorphosis, together with the bonding and growth of bond areas at contact points between adjacent granules leads to increased snow strength (Vigneault and Gameda, 1994).

Colbeck (1979) described the effect of different salinity on the compaction of unsaturated snow (compaction here is understood as density). Colbeck shows that different salinity in snow gives a different degree and rate of compaction. He shows that the rate of compaction decreases rapidly with increasing salinity. The important question is how this relates to the mechanical strength of snow and the compaction of snow that can take place on road surfaces. Colbeck has tested snow compaction under confinement and these tests cannot be directly related to the process of compaction of snow on road surfaces.

Colbeck (1997) states that dry and wet snow (containing liquid water) must be seen as two different materials. At the same time there are differences within these two categories. Wet snow with high liquid content is cohesionless and slushy, while wet snow with low liquid content is well bonded. Dry snow with rapidly growing grains lacks bonding, but has strong bonds if grains grow slowly. A possible hypothesis to explain anti-compaction with chemical application is that the liquid water content of the snow is increased and thereby affects the snow compaction.

Since the underlying mechanism of anti-compaction is not well known or described, there are several questions that cannot yet be assessed on a theoretical level:

- Do the same factors define the effectiveness of anti-icing (freezing point depression), de-icing and anti-compaction, i.e. will a chemical that effectively lowers the freezing point of water also be effective for anti-compaction?
- What is the optimal rate for anti-compaction?
- How is the effect of anti-compaction temperature-dependent?

3.3.2. *The practical aspects of anti-compaction*

Although the phenomenon of anti-compaction is not well described at a theoretical level, the practical utilization of it is well known. Amongst experienced maintenance personnel there is a consensus on some general principles for the successful use of chemicals during snowy weather. A proactive approach with salt application before snow starts to fall or at least at the beginning of the snowfall is important to prevent the bonding of snow. Frequent plowing combined with salt applications with moderate or low spreading rates during snowy weather will provide the best driving conditions and also the lowest total salt usage. Regarding other aspects of chemical application during snowy weather there may be disagreement amongst personnel. Appropriate spreading method is one example. To the author's knowledge there is a relatively widespread opinion amongst maintenance personnel that dry or pre-wetted salt is the best spreading method during snowy weather, while some quite persistently claim that liquid spreading is also best during snowy weather.

3.4. De-icing

Thirdly, the last way of utilizing chemical application in winter maintenance of roads is called de-icing. When ice has formed on the road surface, chemicals are applied to melt and to ease the mechanical removal of the ice from the road surface. When using chemical methods for de-icing purposes, the physical effect of melting ice with chemicals is utilized.

3.4.1. *Melting of ice*

The physical effect of chemicals melting ice is closely related to the effect of freezing-point depression. If a soluble chemical that acts as a freezing-point depressant is spread on ice or snow, it will melt it. When water is frozen there is always a movement of water molecules between the solid and liquid phase, but if the temperature and pressure are constant there is equilibrium in these movements. If a freezing point depressant is added, this equilibrium is shifted and the ice will start to melt (Kim and Yethiraj, 2008). The movement of water molecules from the solid phase requires energy, and therefore if the process is adiabatic the temperature in the ice/water mixture will drop.

Because there is a close relationship between freezing-point depression and ice melting, the same factors that make a chemical an effective freezing-point depressant also optimize the capacity for melting. A low molecular or ionic weight means that the chemical will further reduce the freezing point and also theoretically have a higher melting capacity compared to a chemical with high molecular weight. The melting capacity can be seen as the quantity of ice that one weight unit of chemical can melt (g/g). Theoretically, the melting capacity is determined by the molecular or ionic weight and the solubility of the chemical, in the same way as the freezing point depression is determined. The eutectic temperature shown in Figure 3.2 defines the lowest temperature at which the specific chemical can melt ice. (Chappelow et al., 1992)

It is important to realize that there is a difference between the melting capacity and the melting rate. The melting rate will be determined by other factors than the molecular weight and solubility (Chappelow et al., 1992). These factors are not well known and there are few studies related to chemical melting of ice on roads. (Koefod, 2008)

3.4.2. Penetration and undercutting

When chemicals are used in winter maintenance for de-icing purposes, the spreading rate of chemical will seldom or never be sufficient to totally melt all the ice or snow. Still, there are mechanisms related to the melting of ice that facilitate the mechanical removal of the ice or snow either by plowing or due to traffic. These mechanisms are called penetration and undercutting (Chappelow et al., 1992 and Trost et al., 1988).

When a chemical is spread on an ice-covered road surface, the chemical granules will penetrate the ice and create melting between the ice cover and the road surface. The bond between the ice and the road surface is broken. The ice can then be removed by either traffic or plowing. The mechanism of penetrating and undercutting means that the chemical applied is not intended to melt the total quantity of ice on the road surface. The spreading rates can thereby be reduced compared with the rates required for total melting.

The photo below shows an ice-covered road after de-icing during field trials (Vaa, 2005). The white circles on the ice surface show that penetration and undercutting has taken place.



Figure 3.4 Penetration and undercutting on an ice-covered road surface. Photo, Torgeir Vaa (Vaa, 2005).

3.5. Different chemicals for snow and ice control

Numerous chemicals are proposed and to a certain degree also used for snow and ice control purposes. The different chemicals can be classified according to the following table (the table is not complementary):

Table 3.2 Different chemicals that can potentially be used for snow and ice control.

Group	Example of chemical	Chemical formula
<u>Chloride salts:</u>	Sodium chloride Magnesium chloride Calcium chloride	NaCl MgCl ₂ *6H ₂ O CaCl ₂ *2H ₂ O
<u>Organic salts:</u>	Calcium magnesium acetate (CMA) Potassium acetate Sodium formate Potassium formate	CaMg ₂ (CH ₃ COO ₂) ₆ CH ₃ COOK HCOONa KCOOH
<u>Other:</u>	Urea Different types of alcohol	

(Transportation Research Board, 2007), (Vaa and Sakshaug, 2007), (Holen, 2010), (Minsk, 1998)

These various chemicals can also exist as different products and under different product names.

There are several factors determining whether a chemical is suited for snow and ice control purposes. The most important factor is the effect of the chemical for the described mechanisms of anti-icing, de-icing and anti-compaction, the three purposes of chemical application in winter maintenance. As stated earlier, the effect on the three mechanisms is closely related to the colligative property of freezing-point depression of a chemical soluble in water. As shown, a chemical's ability to lower the freezing point is determined by the molecular or ionic weight. The molecular or ionic weight combined with the solubility in water will determine the eutectic point.

In addition to the effect of the chemical itself, other factors have to be taken into consideration:

- Price
- Environmental effects
- Effects on materials (metals and concrete)
- Storage and handling properties

Sodium chloride is the most commonly used chemical for snow and ice control purposes (Transportation Research Board, 2007 and Vaa and Sakshaug, 2007). This is due to relatively low cost, good availability, ease of storage and handling, and effectiveness for freezing-point depression. At the same time the negative environmental effects of sodium chloride are well known, as is the effect of corrosion.

For chloride salts in general the effectiveness for freezing-point depression is good, due to low average ionic weight. This can be compared to organic salt, which in general has a higher molecular weight and is therefore less effective in lowering the freezing point.

Kai Rune Lysbakken

4. A REVIEW OF THE LITERATURE ON SALT QUANTITY AFTER APPLICATION

A few studies of the salt quantity on road surfaces after salt application have been conducted previously. The goal or focus of these studies can be divided into two categories. The first category was to investigate the effect of different spreading methods on the salt quantity after application, while the second was to develop models for predicting the quantity of salt on the road surface as a function of time or traffic.

The spreading of salt as brine and pre-wetted salt was tested in a Finnish study presented by Raukola et al. (1993). Raukola et al. also investigated any possible differences between liquid calcium chloride and liquid sodium chloride. In the Finnish study the salt measurements were carried out using the Sobo 20 instrument. The change in salt quantity was presented as a function of time as well as traffic. Raukola et al. did not find any differences in the decline in salt quantity after application between liquid calcium chloride and liquid sodium chloride. Further, the conclusion was that loss of salt from the road surface is more rapid soon after application, after which the loss rate will diminish. The study showed that generally there was a very rapid decay in salt quantity and also that a high application rate disappeared more rapidly than a low application rate.

A Swedish study was presented by Ericsson (1995). This study investigated the change in salt quantity after application depending on different road surface conditions. The study also investigated the salt quantity on the road surface with different spreading techniques. Based on the results from the study, Ericsson states that the quantity of water on road surfaces is important for the decline of salt quantity after application. The initial loss of salt at the time of spreading is also highly determined by the road surface conditions and the quantity of water on the road surface. Ericsson also states that there are considerable differences between the initial loss and the change in salt quantity between different spreading techniques. Idealized curves are presented for the salt quantity after application, as a function of time both for different spreading techniques and road surface conditions. No data is presented in this report that supports the results, curves and claims. The report by Ericsson does not state what measuring technique was used for salt measurements, other than stating that it was a hand-held instrument.

Fonnesbech (2001) presented results from a Danish study comparing brine application to the spreading of pre-wetted salt. Tests were performed on ordinary roads with traffic. Salt on road surfaces was measured with Sobo 20. Both cross-distribution and the change in salt quantity after application are presented. Some statistical analysis was made and the relationship between salt quantity and time or traffic is expressed using linear regression curves. According to Fonnesbech the regression models showed that traffic was a more important factor for roads with high traffic volumes than for roads with low traffic intensity. This was explained by arguing that on low traffic-volume roads, other factors than traffic are more important for change in the salt quantity. These factors were not identified and discussed by Fonnesbech.

Burtwell (2004) presented a UK study that compared the spreading of pre-wetted versus dry salt. In the study some trials were conducted on a research track closed to traffic. The tests on the research track could then be stated only as investigating the initial loss using these two spreading techniques. Other tests were conducted on a road with traffic. The salt measurements were conducted with a wet vacuum cleaner. From the trials Burtwell concluded that pre-wetted salt has lower initial loss compared to dry salt and also that with pre-wetted

salt one achieves a more uniform spreading than with dry salt. The salt quantity as a function of time or traffic is not presented in the study.

A Swedish study of salt on road surfaces is presented by Blomqvist and Gustafsson (2004). This study investigated the spatial distribution in the cross-section of the road and the change in salt quantity as a function of traffic. Field observations were conducted on an ordinary road with traffic and salt was measured with Sobo 20. The results show clearly that salt will gather between wheel tracks and in the middle of the road. A model for the quantity of salt in wheel track as a function of traffic was developed. Blomqvist and Gustafson presented an exponential equation for describing the decline of salt quantity inside the wheel tracks:

$$RS = S \cdot e^{-k \cdot PC_{eqacc}} \quad (4.1)$$

Where:

RS = Residual salt [g/m²]

S = Salt used (spread salt) [g/m²]

k = Constant

PC_{eqacc} = Accumulated private car equivalents

The traffic data was calculated as the accumulated number of private car equivalents. Heavy trucks and buses were counted as five private cars and heavy trucks with trailers were counted as seven private cars. The choice of coefficients was not discussed in the paper. The equation was tested on two field observations and resulted in somewhat different values for k (- 0.2027 and - 0.153). Blomqvist and Gustafsson presented different road surface wetness, different road surface characteristics, different traffic composition or the use of other winter maintenance equipment as possible reasons for different k values in the two field observations.

Hunt et al. (2004) presented a study with the aim of developing a predictive model of the quantity of salt after brine application as a function of time, traffic and type of pavement. Like Blomqvist and Gustafsson, Hunt et al. also used an exponential function for describing residual brine decay in their model. The conclusions of this study were that brine decay was mainly dependent on traffic and that there was no correlation between the quantity of brine decay and environmental conditions, i.e. air temperature, pavement temperature, wind speed and air humidity. It must be mentioned that this test seems to have been performed during summer conditions on dry road surfaces. Furthermore, the study showed that the pavement types had a significant influence on the decline in salt. The study also concludes that there was no significant difference in the regression coefficients using salt quantity as a function of time or traffic. Hunt et al. explains this by the fact that traffic is dependent on time.

Russ et al. (2008) conducted a follow-up study to the work of Hunt et al. (2004). This study also focused on the change in salt quantity on different pavement types. Salt was spread as brine on pavements of Portland Cement Concrete (PCC) and on Asphalt Concrete (AC). Russ et al. concludes that salt dissipation generally fits with an exponential model. PCC pavements have slower decay than AC pavements. Russ et al. have used the same definition for traffic as Blomqvist and Gustafsson (2004), the PC_{eqacc}. Using this definition, Russ et al. arrives at much slower decay than Blomqvist and Gustafsson.

Blomqvist et al.(2011) presented a study based on data from Danish road weather stations. These stations are equipped with road surface sensors that are able to measure the salt quantity, the freezing point and the water film thickness on the road surface. The database of

The quantity of salt on road surfaces after application

the Danish Road Weather Information System also included data on reasons for callouts and salting actions (e.g. time and dosage). The data was used for further development of the empirical model presented in Blomqvist and Gustafsson (2004). This empirical model described the decline of salt by an exponential function presented in equation 4.1. 18 single cases of salting actions, mainly on rime, were analyzed. The coefficient governing the rate of decay in salt quantity, k , was found for each of the single cases. Blomqvist et al. investigated the relationship between the modeled k -values and the mean water thickness and found that the relationship could be described by the function:

$$k = a \cdot W^b \quad (4.2)$$

Where:

- k = Coefficient that governs the rate of salt decay
- a and b = Constants ($a = 44,16$ and $b = 1,49$)
- W = Mean water film thickness

The positive trend of the function means that the wetter the road surface is, the faster the decay in salt quantity. The combination of equation 4.1 and 4.2 resulted in an improved model. Further Blomqvist et al. suggest the improved model could be represented in the form of a nomogram as a tool for decision makers.

There are several differences in how these studies have been carried out. These differences can be divided into:

1. Different road and weather conditions
2. Different spreading methods and parameters (speed and width)
3. Different methods for performing salt measurements
4. Different pavement types and textures.

These differences make it difficult to compare the studies and may also explain the different results obtained. Russ et al. (2008) briefly mentioned some of these differences and they stated that time, as well as traffic, affects salt residue. It is likely that time is a factor in the sense that some processes are purely time-dependent, not traffic-dependent. These processes are related to the weather and road surface conditions. An example is run-off from the road surface due to precipitation. The spreading method will influence the change in salt quantity after application. In the studies reviewed, Blomqvist and Gustafsson (2004) examined the spreading of pre-wetted salt while Russ et al. (2008) and Hunt et al. (2004) examined brine application. In addition to spreading method, it is likely that factors like speed and width of spreading influence the change in salt quantity after application. Measuring procedures as well as the type of instrument used may also influence the results of the measurements, as mentioned by Russ et al. (2008). Where in the cross-section profile of the road the measurements are performed, the number of repeating measurements and how often they are performed will likely affect the results of the measurements. Finally, as proved by Russ et al. (2008) and Hunt et al. (2004), different road surfaces (pavement types) will affect the change in salt quantity after application.

In spite of the previous studies, the understanding of the physical processes that control the change in salt quantity after salt application remains imperfect. Models that are developed are based on regression analysis and curve fitting to linear or exponential functions, and not based on the physical processes. The physical processes are generally discussed very little or not at all, while the quality and limitations of the salt measurements and the possible consequences for any analysis are also very little discussed. Defining the physical processes, and the

Kai Rune Lysbakken

important factors influencing the processes, allows a more systematic approach to the phenomenon. Investigating and defining these processes is the goal of this study.

5. FIELD OBSERVATIONS

To investigate the questions addressed in this study, field observations have been conducted. By measuring the quantity of salt after application under different weather and road surface conditions, the aim has been to identify the physical processes and important parameters behind these processes.

5.1. Field observations procedure

The field observations have been carried out on an ordinary road, open for traffic. The method has been to document the salt quantity before and after application and in addition the road and weather conditions during periods of ordinary maintenance actions.

5.1.1. The observation point

The field observations were conducted on the E6 national road, south of Trondheim, Norway. The road is a typical two-lane road and the road and observation point were chosen mainly because of practicalities in relation to the field observations. The traffic volume on this road is low enough to allow measurements of different parameters on the road surface without closing the road entirely. At the observation point there is a bus stop on both sides of the road, allowing vehicle and personnel (the author) a safe place to position themselves during the observation period. In addition to these practicalities, at the observation point there is also a Road Weather Information System (RWIS) station allowing continuous logging and monitoring of weather data. There is also permanent logging of traffic data at the observation point.



Figure 5.1 The road chosen for field observations.

Traffic characteristics

The average annual daily traffic (AADT) at the observation point is approximately 5000. The average proportion of heavy vehicles is 20.1, 20.5 and 21.2% for 2005, 2006, and 2007, respectively. A heavy vehicle is defined as a vehicle with a length of over 5.6 meters. See also section 5.4.2.

There is a significant difference in the daily traffic throughout the year and traffic volume is lowest during winter time (November, December, January, February and March).

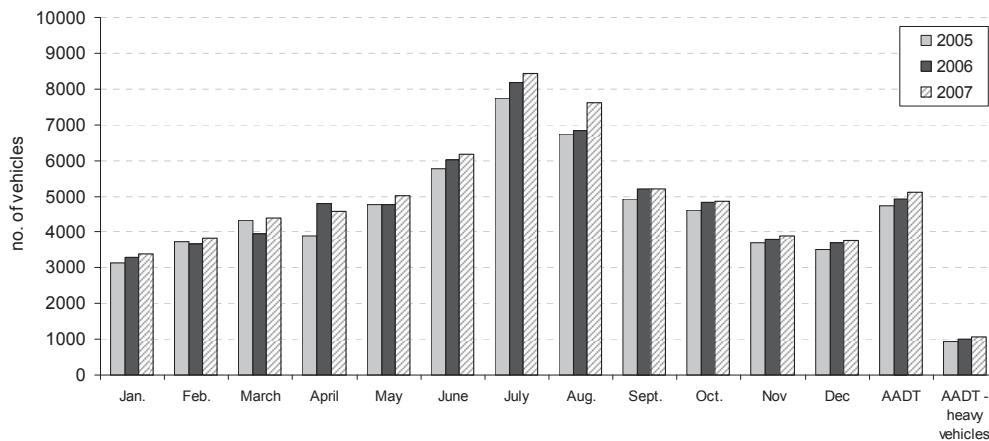

Figure 5.2 Monthly traffic volume at observation point in 2005, 2006 and 2007.

As an example of the daily variations in traffic, the number of vehicles during a 24 hour period on 27 February is shown in Figure 5.3. As shown, there are variations in the traffic during the day. There is a peak in traffic in the afternoon and low volume of traffic during the night. The same tendency is not shown for the number of heavy vehicles in peak-hour traffic, although there are also variations over a 24 hour period for heavy vehicles.

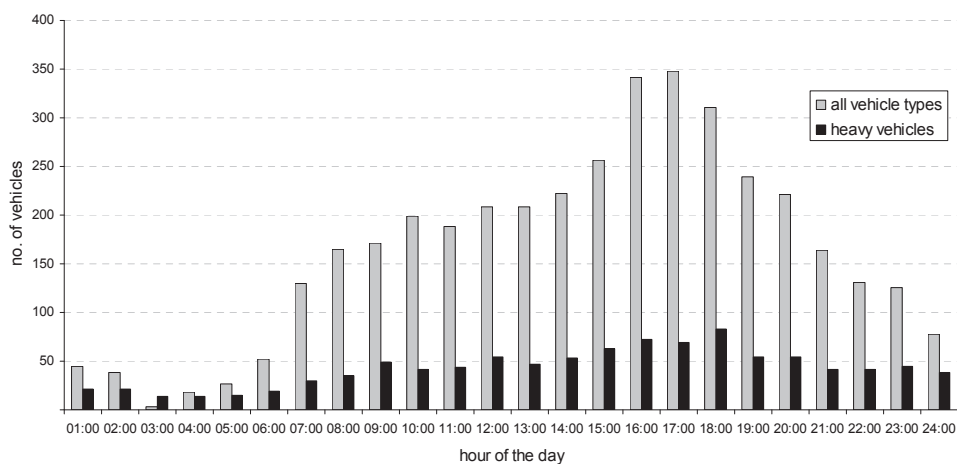

Figure 5.3 Example of hourly traffic in a 24 hour period (27 February 2007).

The quantity of salt on road surfaces after application

The variation in monthly or daily traffic is not a problem for the analysis since the observation point is permanently equipped with instruments collecting traffic data. This provides continuous data on the number of vehicles hourly during the observation periods.

Road geometry and road surface characteristics

The road at the observation point is on a curve with a radius of approximately 500 m. There is a cross-fall of approximately 5%. The road width at the observation point is approximately 7.6 meters measured on the paved area. Between road markings the width is approximately 7.0 meters.

The pavement type is a so-called Asphalt Concrete with maximum grain size of 16 mm. The pavement was repaved in late August 2003. This road section was later repaved in 2011. This is dense, not open-graded asphalt. . The texture can be characterized by a mean profile depth (MPD) of 1.26 mm measured in August 2007. A close-up picture of the road surface is shown in Figure 5.4.



Figure 5.4 The road surface at the observation point.

The rutting depth of the road surface is shown in Figure 5.5.

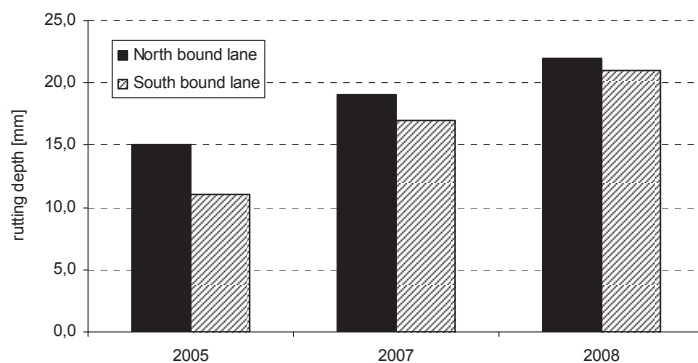

Figure 5.5 Rutting depth at observation point.

There are no data on rutting depth in 2006 and therefore data from 2008 are shown here to illustrate the increase.

Winter maintenance standard

The winter maintenance standards for the road require that it should be free of ice and snow except during periods with snowfall. After a snowfall the road surface should be free of ice and snow within 4 hours. The winter maintenance standard requires that chemical methods are used along with plowing for snow and ice control.

Salt is mostly spread as pre-wetted salt (with 30% water) and sometimes as dry salt.

5.1.2. Carrying out observations and measuring procedures

The observations were made during periods with ordinary winter maintenance procedures and therefore in periods with weather conditions requiring winter maintenance actions. This could typically be during light snow or clear-up at the end of a snowfall or wet/moist road and cold road surface. Because of the limitations of Sobo 20 (instrument chosen for salt measurements), observations could not be performed during periods of heavy snowfall.

When investigating the salt quantity *after* application, it is crucial to know the quantity of salt residue *before* application. Thus, it was also essential to perform salt measurements and other data recordings in a short period before salt application. To manage to perform measurements before salt application, one had to decide to carry out observations at an early stage. That decision was based on checking the weather forecast and data from the RWIS-station, and thereby assessing whether salt application was needed or not. This naturally led to situations where a decision was made to carry out observations, but the prevailing weather situation did not result in salt application.

The quantity of salt on road surfaces after application

For the different types of measurements on the road surface, certain specific measuring points in the cross profile of the road were defined. The measurements related to the road surface (e.g. water and salt quantity) are thereby related to these predefined points. Figure 5.6 shows the predefined measuring points in the cross profile.

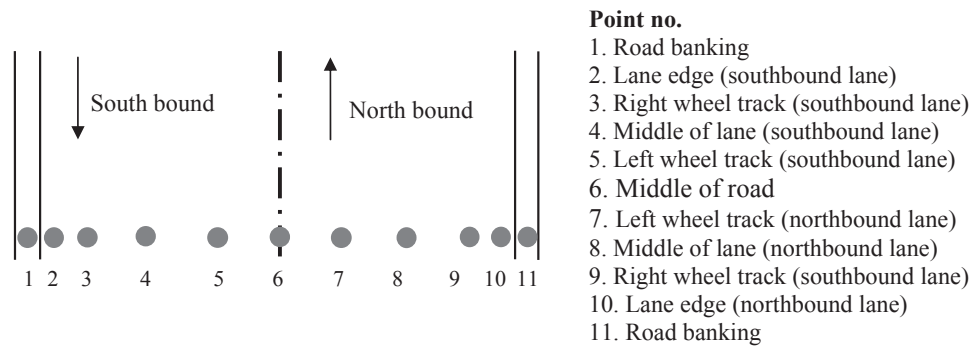

Figure 5.6 Measuring points in the cross profile of the road.

During the observations, measurements of different data were conducted at short intervals. Immediately after salting, measurements were conducted approximately every half hour. Approximately 3 hours after salting, measurements were conducted on an hourly basis. The observations had durations in the range of 5 to 14 hours.

The measuring program (type of measurements, number of measurements in time or space) was a compromise, balancing the desire to measure as much as possible as often as possible, with practical challenges. It was desirable to perform measurements on the road surface or in the road area for only short periods. Firstly, the observations were performed on an ordinary road open for traffic, with only the author performing measurements, and therefore for safety reasons it was necessary to stay on the road for as short a time as possible. Secondly, a goal was to perform measurements of all data types within a single period of time that could be seen as one uniform period in terms of traffic. The aim was for all types of measurements for one period to be taken at approximately the same traffic volume.

5.1.3. Type of data collected

During the field observations data was recorded both manually and automatically. The data that are relevant and used in this study are:

- Manually collected data:
 - Salt quantity on road surface (Chapter 5.2 and 6)
 - Water quantity on road surface (Chapter 5.3)
 - Weather parameters (Chapter 5.4.3)
- Automatically collected data
 - Data from maintenance trucks (also sometimes manual) (Chapter 5.4.1)
 - Traffic data (Chapter 5.4.2)

The different techniques and procedures for measuring data are presented in the following chapters.

5.2. Measuring salt quantity on road surfaces

The salt measurements were conducted using the portable measuring instrument Sobo 20 from Boschung. A more detailed description of the instrument is presented in Chapter 6 and in Paper V.

Salt was measured on the road surface according to the system of measuring points shown in Figure 5.6. During the winter of 2005/2006, salt measurements were performed once at each point from 1 to 11. It was desirable to have measurements in the whole cross profile of the road and it was assumed that the salt would be evenly distributed in the longitudinal direction. For the 2006/2007 season the measuring procedure was altered so that measurements were performed only at points 3, 4, 8 and 9. This corresponds to the right wheel track and between wheel tracks in the south and northbound lane. However, at each point three repeating measurements were performed. The reason for altering the measuring procedure was a desire to have more representative measurements at each point. After having analyzed data from the first measuring season, it was realized that there can also be a significant spatial variation in the longitudinal direction of the road. Performing only one measurement at each point will probably not always give representative measuring results. Because of a desire for the measuring periods on the road to be as short as possible, it was decided to measure at only four points but with three repetitions at each point. It would certainly have been desirable to perform measurements at all eleven predefined points and with three repetitions. This desire could not be reconciled with the demand for short measurement periods on the road.

5.3. Measuring water quantity on road surfaces

The quantity of water on the road surface was measured by a simple method using a highly absorbent textile called Wettex. By placing a textile piece of known dimensions (0.265×0.410 m) on the road surface, the liquid present on the road surface will be absorbed. The quantity of water can then be determined by weighing the textile before and after absorption. During the measuring procedure the textile piece is “pushed and rubbed” against the road surface. The textile piece is laid on the road surface for approximately 15 seconds. The use of the Wettex is shown in Figure 5.7.



Figure 5.7 Measuring quantity of water on road surfaces with Wettex.

It is recognized that this is a simple and rudimentary method of estimating the quantity of water on the road surface. On the other hand the method has some advantages. It provides a simple and rapid estimation of water quantity and demands no further instrumentation besides a weighing scale.

The quantity of salt on road surfaces after application

Different questions can be addressed regarding the uncertainties of water quantity measurements with Wettex. What is the accuracy of the measurements? How well do the measurements reflect spatial variation of water quantity on a road surface and what are the limitations (detection limit) when it comes to minimum or maximum water quantity? Some potential sources of error with the method can be identified. These are:

- Incomplete absorption of the water
- Absorption of dust from the road surface
- The spatial variation of the quantity of water

By performing three repeating measurements, calculating the average from the three measurements and plotting the deviation for each measurement, Klein-Paste (2008b) calculated a deviation or error which gives a 95% confidence interval, here denoted as R. The calculation of the error is based on 186 measurements and is described by the following equation:

$$R = \pm(0,1 \cdot m_{\text{water}} + 20g / m^2) \quad (4.3)$$

Where:

$$m_{\text{water}} = \text{quantity of water in } g/m^2$$

If the water quantity, m_{water} , is measured by Wettex to be $200 g/m^2$, the R will be calculated to be $\pm 40 g/m^2$. The water quantity can then be said to be between 160 and $240 g/m^2$ with a confidence of 95%.

The method of using Wettex for measuring water quantity was also tested by Blomqvist and Gustafsson (2012). They tested the Wettex textiles on three asphalt samples with different textures. By adding water on a defined area with a sponge, and weighing the sponge before and after application, the quantity of water on the road surface was known. The conclusion of the tests was that the wetness of a road surface can be well established using the method of Wettex textile, but the degree of underestimation seemed to be positively related to the road surface texture

The water quantity was normally intended to be measured in point 3, 4, 8 and 9 according to Figure 5.6. This corresponds to right-wheel tracks and between-wheel tracks in both south and northbound lane. It was also intended to measure the water quantity each time the salt quantity was measured. The procedure of measuring with Wettex was relatively time-consuming, taking into account that the measurements were performed on a road open for traffic. Therefore, in several cases measurements of water quantity were not performed at all four points or each time salt quantity was measured. This was especially the case in periods with relatively high traffic volumes.

Further, the water quantity has mostly been used to classify the wetness of the road surface. The classification of road surface wetness was according to the definition given in Table 5.1.

Table 5.1 The classification of road surface wetness.

Road surface wetness	Quantity of water [gr/m ²]	Equivalent water film thickness [mm]
Dry	0	0
Moist	0-100	0-0.1
Wet	>100	>0.1

A definition of moist road surface is that there is no spray phenomenon from vehicles, while there is spray from vehicles on a wet road surface. It is assumed the spray phenomenon will occur at a water-film thickness of 0.1 mm. This assumption can certainly be discussed and will probably depend on factors like road surface texture, tire texture of vehicles and traffic speed. In a Finnish study by Raukola et al. (1993) another more detailed definition of road surface wetness is presented. A more detailed classification of road surface wetness requires a detailed study of the phenomenon and is not included in this study. The classification for each observation was based on the average quantity of water on the road surface during the observation. Since there is also considerable variation in the cross profile of the road, and the later analysis is mainly of the salt quantity in wheel track, the water quantity in wheel track was chosen for classification of road surface wetness.

5.4. Other measurements

5.4.1. Maintenance data

Crucial for the outcome of the field observation was detailed information about the salt application. To study the quantity of salt after application required exact information about the time and dosage of salting. For the purpose of this study the contractor responsible for the maintenance was required to have an automatic vehicle location (AVL) system for logging data on the maintenance activities on this road section. This system logs the maintenance vehicle position in addition to, for example:

- Time of salting
- Application rate
- Spreading method
- Spreading width
- Spreading pattern
- Whether plowing is carried out

During the first season of observations (2005/2006) several problems were experienced with the AVL system and consequently a potential lack of maintenance data. Therefore, maintenance data were also collected manually. Maintenance personnel were instructed in filling out forms about the maintenance action at each time of passing the observation point.

Although there was both manual and automatic registration of maintenance activities, it was often found that there was a lack of maintenance data during some observation periods. These observations did not provide complete data sets and were therefore not successful or possible to use for further analysis.

5.4.2. Traffic data

At the observation point the road is permanently equipped for collecting traffic data. There are inductive loops (cables) embedded in the road surface that detect and classify vehicles. The data is logged on a timely basis. Vehicles are divided into two categories according to the length of the vehicles. Vehicles with a length of over 5.6 meters are classified as heavy vehicles (buses, trucks and trailers) and vehicles with a length of less than 5.6 meters are classified as private cars. The equipment and system for classification of traffic is a standard system used by the NPRA. This provides only a rough classification of vehicles and does not distinguish between small trucks, buses or heavy goods vehicles.

5.4.3. Weather data

Despite the observation point being equipped with an RWIS station it was decided to measure essential weather parameters manually with mobile or handheld equipment. This was done because it was noticed that there was often a lack of data in the RWIS station log at different periods. It was crucial to ensure essential data on the weather.

These weather parameters were recorded:

- Air temperature
- Dew point (humidity)
- Road surface temperature
- Precipitation

Air temperature and air humidity were measured with a hand-held instrument called Novasin ms1. Road surface temperature was measured with an infrared thermometer called Fluke 66.



Figure 5.8 Measuring air temperature and humidity and road surface temperature.

Precipitation was measured by collecting precipitation with a rain gauge (bucket) that was mounted on a tripod. The bucket was weighed approximately every hour during periods of precipitation to calculate the precipitation in mm of water. See Figure 5.9.

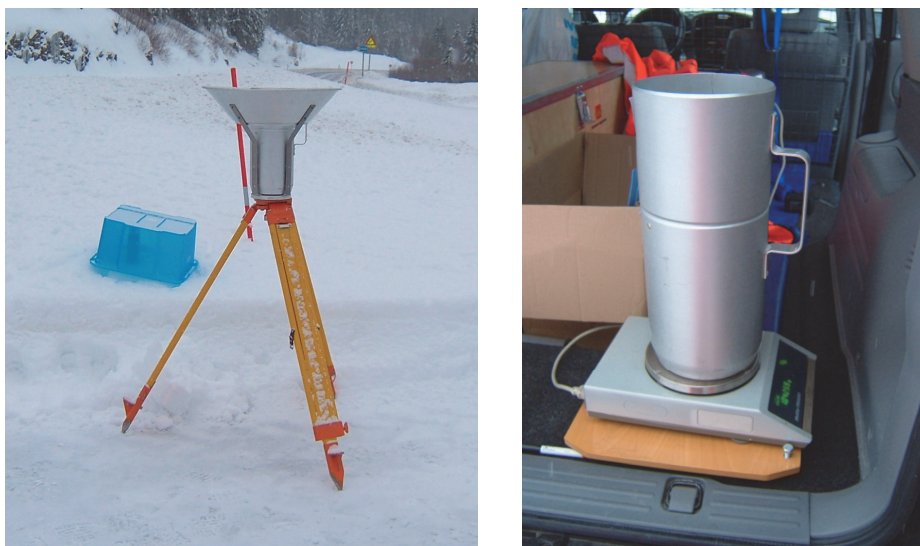

Figure 5.9 Equipment for registration of precipitation.

5.4.4. Photographic documentation and description of road surface condition

In addition to the data collected, the weather and road surface conditions have been documented photographically in addition to a verbal description/characterization.

Each time measurements have been conducted the weather has been described and precipitation has been characterized according to different types:

1. fine
2. drizzle
3. rain
4. sleet
5. snow
6. fog

The road surface conditions are often different in wheel tracks and outside wheel tracks. Therefore the road surface conditions were characterized separately in and outside wheel tracks according to the following types:

1. Dry bare road
2. Wet bare road
3. Slush
4. Loose snow
5. Hard snow layer
6. Ice
7. Thin ice
8. Rime

6. MEASURING SALT ON ROAD SURFACES

The most essential part of the field observations was the measurements of the salt quantity on the road surface. The choice of measuring instrument for this purpose was therefore of great importance. There are several measuring techniques or methods that are proposed or tested for the purpose of measuring salt quantity on road surfaces. However, there are relatively few instruments that are fully developed and commercially available.

6.1. Salt concentration versus salt quantity per unit area

There are in principle two possible units of measure for salt on road surfaces: 1) salt concentration or 2) salt quantity per unit area (g/m^2). The salt concentration can be expressed as concentration in the fluid (grams per liter or weight percentage) or as freezing point (a function of salt concentration). As stated by Turunen (1997), for historical reasons or for the sake of descriptiveness it has become customary to express salt content on road surfaces as freezing point temperature or freezing point depression. The fact that the concentration of salt is certainly the easiest to measure because it can be measured directly is in the author's opinion the most important reason for this. If one wants to measure salt in quantity per unit area, the water film thickness has to be measured and then the salt quantity per unit area can be calculated. It must be mentioned that measuring water film thickness is, in addition to salt, a major challenge with its own uncertainties. Another possible way of measuring salt in terms of quantity per unit area is that a measuring fluid is added onto the road surface. This corresponds to the principle of Sobo 20.

Having the salt quantity expressed in terms of salt concentration can be problematic both when measuring salt as part of decision support or in research activities. A discussion of the unit of measurement for salt on road surfaces in the context of decision support is presented in Paper I. To conclude it can be stated that knowing the salt concentration alone is not always enough to evaluate the future development of the road surface conditions. Sometimes the quantity of salt as unit per area has to be known. It should be borne in mind that a high salt concentration does not always mean a high quantity of salt per unit area and conversely, a low concentration does not always mean that there is a low quantity of salt per unit area present on the road surface. For example if a decrease in road surface temperature is expected, salt concentration or freezing point is sufficient information to assess whether freezing will occur or not. On the other hand if precipitation as snow is expected, information about freezing point or salt concentration is not enough to assess whether a new salt application is required. In addition to the problem of salt concentration not always providing enough information, the information can be difficult for maintenance personnel to interpret. Guidelines for salt application and control panels for the spreader are all related to salt quantity per unit area. It may therefore be difficult to relate information about salt concentration to other parts of the salting system.

The use of concentration as a unit of measurement in research activities also seems inadequate. This is also the case in this study. Knowing only the salt concentration of the water on the road surface would not provide information about the movements of salt on, to and away from the road surface. Turunen (1997) claims that the total salt quantity on a road surface stays relatively unchanged, while the quantity of water can change drastically due to precipitation, condensation and evaporation. This view is not shared by the author of this study, or by the previous studies presented in Chapter 0. The field observations and measurements presented in this study show that changes in the salt quantity can indeed also

be observed. To learn about how the salt quantity changes after salt application and the processes that control this, it is the author's opinion that salt has to be measured in units of quantity per unit area.

6.2. Possible measuring principles and instruments

There are various possible measuring principles for detecting salt. Generally, all principles are based on measuring a physical property that depends on the salt concentration in the salt solution. According to Turunen (1997) these physical properties can be:

- optical
- thermodynamic
- electrical
- density

A final principle is the use of spectroscopy. According to Turunen (1997) most of these principles are rejected because the instruments would be too expensive or too fragile for the required purpose. However, there has been some research in the field of measuring salt on road surfaces and different techniques and instruments are being tested.

6.2.1. Optical

The use of optical methods for measuring salt normally involves measuring the refraction of light in the fluid and thereby determining the salinity of the fluid. The use of refractometers is well established for measuring the concentration of e.g. sugar, alcohol and salt in water. There is a range of refractometers available that are not especially designed for measuring salt on road surfaces. Both analogue and digital refractometers are available. To the author's knowledge the principle of using refraction for measuring salt concentration is not used in instruments solely designed for road purposes. On the other hand, the optical principle is used in road surface sensors to measure water film thickness (Haavisto et al., 2000).

Jouin et al. (2010) reported a study using another optical method for measuring the quantity and distribution of spread salt. The concept was to analyze digital images of the road surface that are taken after the road has been salted. This method can only measure solid salt grains and the idea is to use this method to test salt spreaders.

6.2.2. Thermodynamic

The thermodynamic principle for measuring salt on road surfaces involves direct detection of the freezing point of the fluid on the road surface. The temperature of fluid present on the road surface is lowered in a cooling process. By monitoring the temperature of the fluid during the cooling process the freezing point can be detected. The freezing point is detected by identifying a change in temperature versus time curve. (Jonsson, 2009). As known, the temperature of a fluid will be constant during the freezing process. This technique is used in some types of road surface sensors.

6.2.3. Electrical

The electrical conductivity of brine will increase with increasing salinity due to a rise in concentration of free ions (Jonsson, 2009). The salinity can be found by measuring the electrical conductivity of a fluid and knowing the relationship of the electrical conductivity. In addition to the salinity, the temperature will also greatly influence the conductivity. Measuring salt concentration by measuring conductivity must therefore also include measurements of temperature to compensate for this temperature dependency. The principle of measuring salinity by measuring electrical conductivity is used in several instruments.

These include both road surface sensors, the Sobo 20 which is used in this study and other instruments that are not specially designed for road surface purposes.

6.2.4. Other possible measuring principles

Turunen (1997) states that the use of a spectroscopic method is also a possible way of measuring salt. Marchetti et al. (2010) published a study of a tool using a spectroscopic instrument for remote and portable measurements of salt on road surfaces. According to Marchetti et al. (2010) a spectroscopic tool is based on recording the characteristics of the vibrations of chemical bonds in a material submitted to incident light. This particular study was conducted in a laboratory and can be seen as a feasibility study of the method. The conclusion made by Marchetti et al. was that the spectroscopic tool was able to run a remote measurement of residual salt on road pavements. According to the study the spectroscopic response was not affected by the type of pavement or common road pollutants tested.

Hammond et al. (2006) published a study of possible monitoring of residual salt when rock salt is mixed with a molasses-based product. Fluorescence techniques were used to identify the fluorescence signal emitted from the molasses-based product. Tests showed that the molasses-based product had a unique fluorescence signal. Using a product with a mix of salt and molasses-based product where the relationship between salt concentration and molasses-based product is constant, fluorescence techniques could be used to monitor the salt concentration. The technique was tested in the laboratory and the study was, as such, a feasibility study. Temperature influenced the fluorescence signal, but it was found to be relatively stable between 0 and 5° C. The remote detection is a problem due to loss of fluorescence signal with distance. The conclusion is that it is unlikely that a sensor detecting the fluorescence signal from several meters away can be developed.

The use of Ground Penetrating Radar (GPR) to detect salt has been investigated in a pilot study by Lalagüe et al. (2009). The GPR transmits electromagnetic waves in the studied structure and records the electrical echoes induced by dielectric property differences between two materials. If the electrical conductivity of the ground increases, the energy is likely to dissipate and then the penetration depth decreases. Based on this, the use of GPR for detecting salt on the road surfaces was investigated in the laboratory. The conclusion was that salt is detectable by GPR when it is present in the form of brine. These tests encouraged further examination of the use of GPR for detecting salt.

The Swedish National Road and Transport Research Institute (VTI) developed a prototype for sampling of road surface particulate matter, the so called Wet Dust Sampler (WDS). The WDS is designed to collect all loose material on a surface (Jonsson et al., 2008). The principle is that a surface is cleaned with a high pressure appliance and an air compressor presses the sampled volume into a collection bottle. The sample can then be studied, for example by chemical analysis for residual salt. The quantity of salt is therefore not obtained instantaneously but further analyses are required after sampling. The accuracy of salt measurements with WDS was tested by Blomqvist and Gustafsson (2012). The conclusion is that WDS is suitable for measuring salt on road surface both in the form of brine, recrystallized salt and dry salt.

In some studies a wet vacuum cleaner or system based on a wet vacuum cleaner has been used to collect and measure salt on the road surface. Burtwell (2004) presented a study where a wet vacuum cleaner was used to investigate the spreading of dry salt versus pre-wetted salt. In a German study, spreading patterns and the accuracy of different spreaders were investigated and a system was developed based on a wet vacuum cleaner to measure salt on road surfaces (Hanke, 2010). As indicated by Hanke the use of such measuring techniques is laborious and not very feasible in trafficked areas.

6.2.5. Road surface sensors

Road surface sensors are instruments designed for decision-support purposes and are often part of a road weather information system (RWIS). There are different types and manufacturers of these sensors and some of the sensors also measure road salt on the road surface. An essential parameter measured by a road surface sensor is road surface temperature. Other parameters that can be measured depending on sensor type are road surface conditions (dry, wet or ice) or even the quantity of water (water film thickness).

According to Peryy and Symons (1991) there are three types of road surface sensors: active sensors, passive sensors or non-contact sensors. Non-contact sensors are mounted on gantries or poles at the side of the road and use microwaves and infrared light to characterize the road surface conditions. These sensors do not measure salt on the road surface. The sensors that are called active and passive sensors according to Peryy and Symons (1991) are sensors that are embedded into the road surface. Passive sensors measure salt by measuring the electrical conductivity of the water on the road surface and active sensors use the thermodynamic measuring principle to detect the freezing point of the water on the road surface. Both these principles mean that the concentration of dissolved salt in the liquid on the road surface can be determined. If the road surface sensor in addition can measure the water quantity (water film thickness), the quantity of salt per unit area can be calculated.

6.2.6. On vehicle systems

There are also instruments that are designed to be installed on vehicles. These instruments are based on the technology used in road surface sensors. These systems analyze the fluid from the road surface based on spray from the vehicle tires. The measuring principle could be either to measure electrical conductivity or to detect freezing point with a cooling sequence. (ASFT, 2011) (Garrick et al., 2002)

6.2.7. A brief discussion of challenges related to measuring salt on road surfaces

There are a number of challenges related to the measuring of salt on road surfaces. There follows a brief discussion of the main challenges related to the topic. This discussion is not meant to be a complete examination of all possible measuring principles or instruments. It only highlights some general and essential problems related to measuring salt on road surfaces.

An important characteristic of nearly all measuring principles or instruments is that salt has to be dissolved to be detected. For example, only dissolved salt contributes to an increase in electrical conductivity and in the same way only dissolved salt will contribute to a freezing point depression. Using electrical conductivity or measuring freezing point depression will only detect the concentration of dissolved salt. That means if there is solid salt present on the road surface the instrument will not measure this and the salt quantity will be underestimated. When spreading salt as dry or pre-wetted salt, solid salt grains will certainly be present on the road surface for some time and this means that the total quantity of salt will be

The quantity of salt on road surfaces after application

underestimated. To the author's knowledge, only the method of using wet vacuum cleaners (modified) and the Swedish WDS are capable of measuring both solid and dissolved salt. As mentioned earlier, these methods are highly labor-intensive and time-consuming.

In addition to requiring the salt to be fully dissolved, most of the instruments require a certain quantity of water to be present on the road surface in order to be able to perform measurements. This is the case for road surface sensors and certainly for the systems being installed on vehicles. There could be said to be a threshold value for the water film thickness for the instruments to produce measurements, or at least to produce reliable measurements. Unfortunately, there is little documentation regarding this threshold value for the different instruments.

Most of the instruments only measure salt on a small area of the road surface. Knowing that the salt is not evenly distributed on the road surface, this can be a problem. This is a particular problem for road surface sensors that are stationary and only measure at a small spot on the road surface. The question is whether these measurements on a single point are representative of the rest of the road surface. A small sampling area is also the case with Sobo 20 instrument that is used in this study. On the other hand, Sobo 20 is a portable instrument and a small sampling area can be compensated for by repeating measurements.

The road surface sensors are embedded into the road surface and consist of a small area of metal that is different from the rest of the road surface. The question is whether this difference in surface characteristics can affect the reliability of the sensor. It is reported that there is at least a problem in achieving sensors that are leveled to the road surface in such a way that water does not gather or drain off from the sensor.

6.3. Sobo 20

When deciding on an instrument to measure salt on the road surface in this study, it was clearly desirable to have an instrument that measures salt in terms of quantity per unit area. There are, as mentioned, few instruments that measure or calculate salt quantity per unit area except some road surface sensors and Sobo 20 instruments. The Sobo 20 instrument is a portable one that allows measurements on several locations and in different positions in the cross profile of the road.

The Sobo 20 instrument is a well known and fairly old instrument produced by Boschung. It has been used in several studies on the topic of salt on road surfaces: Raukola et al. (1993), Fannesbech (2001), Blomqvist and Gustafsson (2004), Hunt et al. (2004), Russ et al. (2008) and Klein-Paste (2008b).

6.3.1. Description of the instrument

The principle behind Sobo 20 is based on the measurement of the electrical conductivity of a fluid. The unique feature of Sobo 20 is that the instrument itself adds measuring fluid onto the road surface during the measuring procedure. The measuring fluid is a mixture of 85 weight percentage water and 15 percentage acetone. The acetone is added for frost protection of the instrument.

The instrument consists of four main parts as shown in Figure 6.1:

1. The upper chamber
2. The middle chamber
3. The mouthpiece or measuring chamber
4. The electronic measuring unit.

Main parts of the instrument:

1. Chamber containing the measuring fluid
2. The middle chamber containing one “dosage” of fluid.
3. The mouthpiece or measuring chamber containing electrodes and sensors
4. The electrical unit for measuring the conductivity and calculating the salt quantity

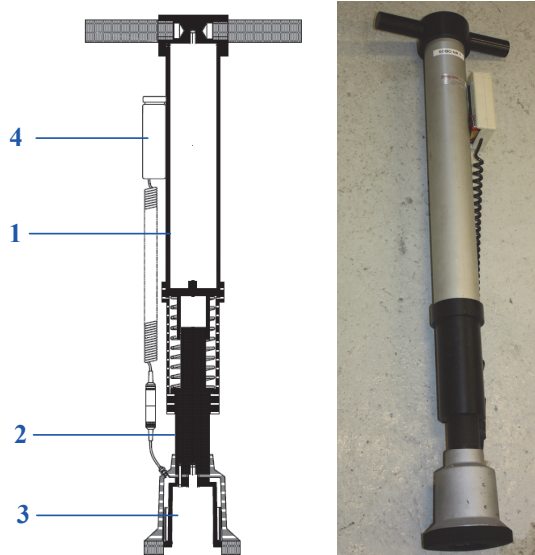

Figure 6.1 Drawing and photo of the Sobo 20 instrument (the drawing of Sobo 20 is taken from Nygaard (2003)).

The upper chamber (1) is a cylinder to store measuring fluid. The cover of the upper chamber is also fitted with handles (grip) for the operator of the instrument. The middle chamber (2) contains one dosage of measuring fluid. The mouthpiece (3) is the measuring chamber. Inside this chamber there are electrodes for conductivity measurements. At the bottom of the mouthpiece there is a rubber gasket and when the mouthpiece is placed on the road surface, this gasket encloses a certain area of road surface. This enclosed area is the measuring area of the instrument. Finally there is the electronic unit (4) of the instrument.

When pushing the instrument against the road, the measuring fluid is sprayed from the middle chamber onto the road surface area enclosed by the measuring chamber. The instrument then measures the electrical conductivity of the fluid inside the measuring chamber. By having a defined area of measurement, a known quantity of measuring fluid and the electrical conductivity, the instrument calculates the quantity of salt on the road surface per unit area (g/m^2). The use of Sobo 20 in a measuring situation is shown in Figure 6.2.



Figure 6.2 The use of the Sobo 20 on a road surface.

6.3.2. Strengths and limitations

There are some characteristics of Sobo 20 that make the instrument unique and made it preferable for this study. First of all, it measures salt in terms of quantity per unit area. It also adds measuring fluid to the road surface which allows measuring when the quantity of water on road surfaces is small. This is in contrast to road surface sensors that require a certain quantity of water on the road surface to achieve recordings. In principle Sobo 20 can be used also on dry road surface, but whether Sobo 20 manages to measure dry or re-crystallized salt is open to discussion. Another important advantage of the instrument is that it is portable and requires no installation or power supply. This allows measurements at different locations along a road section or anywhere in the cross profile of the road. The measuring procedure is simple, the instrument produces instantaneous readings and no further analysis is required.

Obviously the Sobo 20 instrument has some limitations, and several potential sources can be identified that may make the readings inaccurate or even incorrect. Sobo 20 may produce systematic errors that make the instrument over- or underestimate the salt quantity. There are also questions regarding the instrument's performance on road surfaces where salt grains (solid salt) are present. Klein-Paste (2008b) showed it is likely that Sobo 20 underestimates the quantity of recrystallized salt on road surfaces after they have dried up. Additionally, there is the effect of the road surface texture on the Sobo 20 readings. Blomqvist and Gustafsson (2012) published a study of different field techniques for measuring salt and water film thickness. Sobo 20 was also tested. The conclusion of the study was that the Sobo 20 is suitable for measuring salt on wet road surfaces, but shows some underestimations on recrystallized salt and large underestimations on salt crystals. The tests were all performed on asphalt and brine application was made using a sponge.

6.4. Test of Sobo 20

To further document the accuracy and limitations of the instrument, some tests have been conducted. These tests are presented fully in Paper V and as a summary in this chapter. The study presented in Paper V strives to go beyond previous studies of Sobo 20, investigating and quantifying the underlying factors that may affect the accuracy of the

instrument. Those are: the content of acetone in the measuring fluid, the form of salt (crystals or brine) and smooth or coarse surface.

6.4.1. Experimental procedures

Six different tests were performed. Four of the tests were performed on a smooth surface to eliminate the effect of the road surface texture. To study the effect of the road surface texture, two of tests were also performed on an asphalt surface.

The main challenge in testing Sobo 20 was the proportioning and the application of salt or brine on its relatively small measuring area. The diameter of the measuring area of Sobo 20 is 5.6 cm which gives a measuring area of less than 1/400 of a square meter. That means that very small quantities of brine or salt must be applied within the measuring area. Performing the test required equipment for dispensing small volumes of liquid and weighing salt grains. The design and execution of the tests naturally introduce sources of errors: there can be inaccuracies in preparing brines, weighing salt, dispensing a precise volume of solution with the pipette or in placing Sobo 20 onto the area to be measured. Nevertheless, precautions were taken to minimize bias, such as the use of high-precision pipettes and scale. Brines were also always shaken before use to avoid salt decantation and their salt content was regularly checked.

Calibration test

The aim of this test was to investigate whether there were errors directly related to the instrument, with all known sources of error eliminated. This could either be a systematic error (or bias) that makes the instrument consistently underestimate or overestimate the salt quantity, or random errors resulting in a high unsystematic variation in Sobo 20 readings. Small droplets of brine were applied onto glass dish (smooth surface) with a pipette. By applying different volumes of brine at various concentrations one could simulate different salt quantities in the measuring range of the Sobo 20 from 1 to 45 g/m². For each salt quantity tested, ten repetitions were performed.

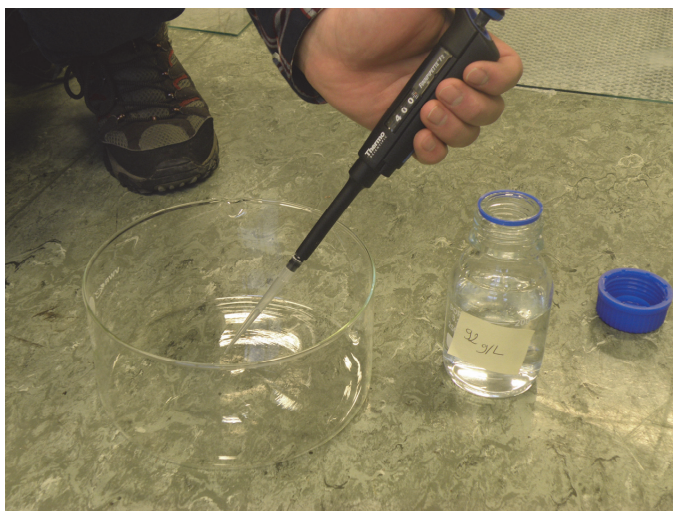

Figure 6.3 Applying brine onto glass dishes.

The quantity of salt on road surfaces after application

Acetone content of the measuring fluid

According to a Danish report on the Sobo 20 (Nygaard, 2005) it is recommended to use only distilled water as measuring fluid and not a mixture of acetone and water as described by the manufacturer. A test was performed to investigate whether the absence of acetone would influence the measuring results. A measuring fluid of distilled water was tested as well as mixtures with 7.5, 15 and 30% acetone. Brine was applied as described for the calibration test. Tests with four different salt quantities in the series of ten repetitions were performed.

Salt grains

This test was performed to quantify the degree of underestimation of Sobo 20 readings performed on dry salt grains. Salt crystals of various weights were applied onto the glass dishes and then measured with the Sobo 20. Salt crystals were selected in a weight range that represents salt quantities in the range of 2 to above 130 g/m². Quantities above the measuring range of the Sobo 20 were tested since it was shown by Blomqvist and Gustafsson (2012) that Sobo 20 was largely underestimating when measuring salt crystals. A weighing scale able to measure 1/1000 gram was used for this test. One measuring series was performed on single salt grains and another series was performed on the combined weight of two salt grains of smaller size. This was done to study the significance of the interfacial surface area of the grains on the Sobo 20 readings. Small grains are expected to dissolve faster and give better Sobo 20 readings, as more surface is exposed and available for dissolution to occur.

Recrystallized salt

To test and quantify the degree of underestimation on recrystallized salt, testing was also performed on smooth surface. Droplets of brine were applied with the pipette used for the calibration test. The droplets were allowed to dry up in room temperature over a twelve hour period. After the water has evaporated the salt quantity was measured with the Sobo 20.

Brine and recrystallized salt on asphalt surface

To test the effect of texture on Sobo 20 measurements, similar tests to the calibration test and the experiment with recrystallized brine were performed on dense graded asphalt on a parking area. Brine droplets were applied to the asphalt surface using a 100 – 1000 µl pipette. For testing brine on asphalt, Sobo 20 measurements were performed immediately after application. For the re-crystallized salt, droplets were allowed to dry and the salt to crystallize. Despite the small volumes applied, nothing could prevent the brine from spreading out widely along the asphalt surface. Therefore brine was dispensed 200 by 200 µl, with a drying time of about 15 min between each application. This constrained the dispersion of the brine on a surface smaller than the Sobo 20 measurement area.

6.4.2. Results

The main results of the test are shown here. For details see Paper V.

Calibration test

The calibration test measured brine on a smooth surface. The results are shown in Figure 6.4.

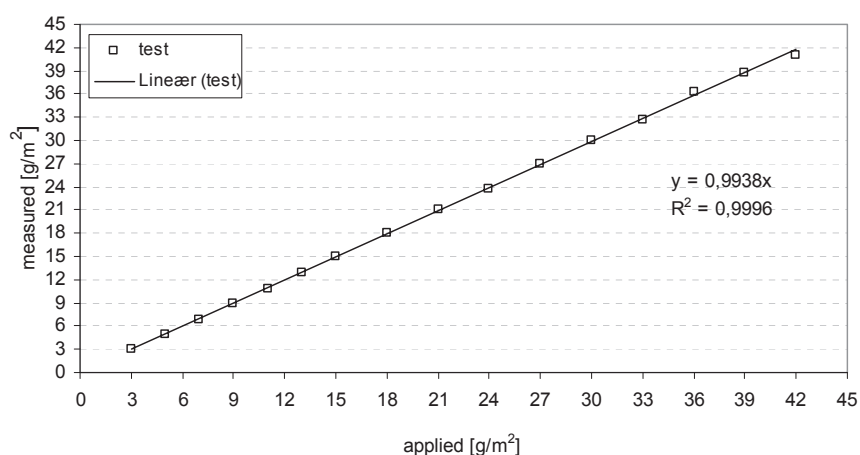

Figure 6.4 Results from the calibration tests.

As shown by Figure 6.4 Sobo 20 is able to measure dissolved salt on a smooth surface quite accurately. As shown by the error bars, the standard deviation for each measuring series is relatively low. Above 15 g/m² the variation seems to increase. This can be explained by the measuring scale of Sobo 20. In the range of 15 to 45 g/m² Sobo 20 measures the salt quantity in increments of 3 g/m² (15, 18, 21...). This will naturally lead to an increase in the variation in the measured salt quantities above 15 g/m². On the other hand, if the standard deviation is calculated as a percentage of the average measured value, one would see that the variation is not increasing with increasing salt quantity, but rather decreasing.

The quantity of salt on road surfaces after application

Test of the acetone content of the measuring fluid

The results from the test of different acetone contents in the measuring fluid of Sobo 20 are shown in Figure 6. Each data point presented is an average of a series of ten measurements.

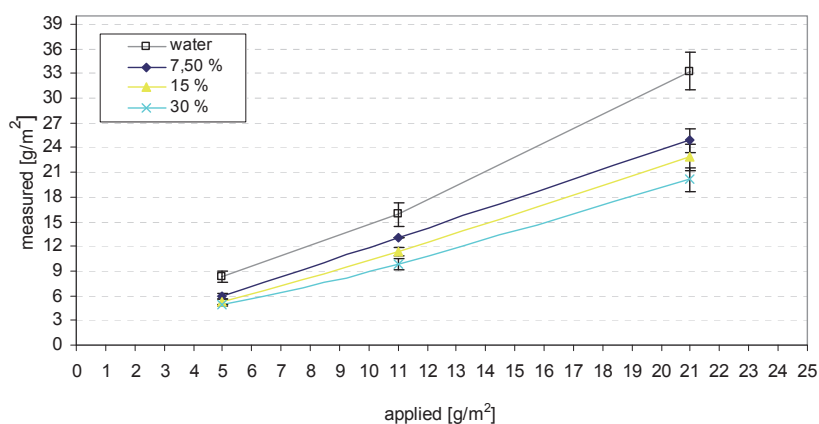

Figure 6.5 Results from the test of different acetone contents in the measuring fluid.

From this test it is evident that a correct content of acetone in the measuring fluid is crucial to obtain a correct reading with Sobo 20. Decreasing acetone content means increasing error in Sobo 20 readings. By using only distilled water Sobo 20 measures salt quantities that are in the range of 45 to 66% higher than the applied quantity.

It is likely that the Danish recommendations to use only distilled water in Sobo 20 have to be followed by a calibration of its electronic unit. It should also be mentioned that the role of acetone is to prevent the freezing of measuring fluid in the instrument, especially in the valves of the instrument.

Measurements of salt grains

The results from the measurements of salt grains are presented in Figure 6.6.

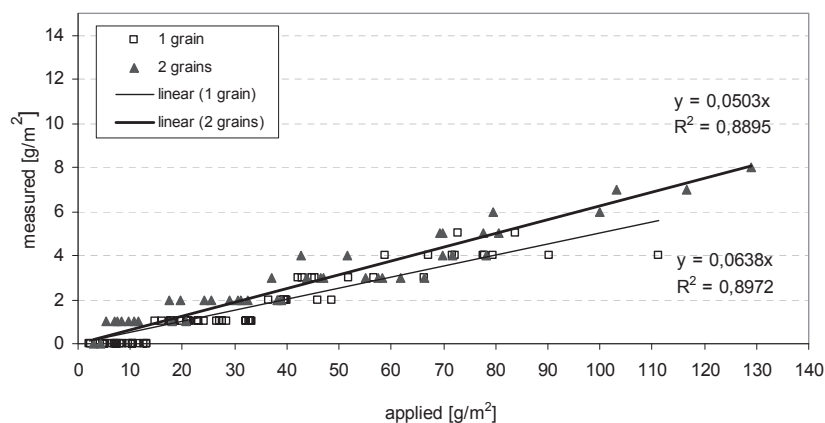

Figure 6.6 Results from the test on measurements of salt grains.

As shown, Sobo 20 largely underestimates the salt quantity when measuring salt grains. For measurement of one salt grain, Sobo 20 only displays approximately 5% of the salt quantity.

For salt grains corresponding to a quantity of 15 g/m² or less, Sobo 20 does not detect any salt at all. When applying the salt quantity as two salt grains, Sobo 20 measures slightly higher salt quantities. In general approximately 6% of the salt is measured. When measuring two grains instead of one grain, the interfacial surface area of the grains per unit weight increases, and therefore the measured salt quantity increases as well.

As can be seen from Figure 6.6, there are substantial variations in the measurements. Some variations can certainly result from uncertainties in weighing up salt grains at an accuracy of 1/1000 grams. It should also be remembered that the salt grains can have different grain shapes and this can result in differences in surface area per unit weight and thereby contribute to some variation in the results. As shown when comparing the test with one and two salt grains, the effect of different surface area can be decisive.

Measurements of recrystallized salt

The results of the tests for recrystallized salt on a smooth surface are shown in Figure 6.7.

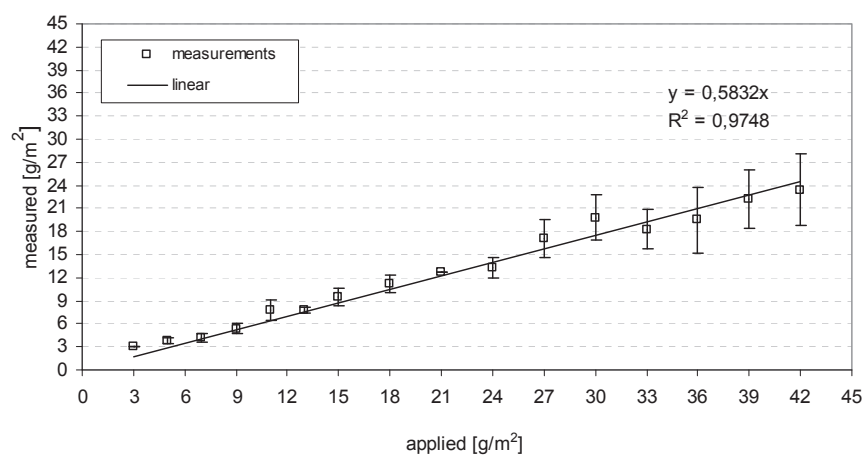

Figure 6.7 Measurements of recrystallised salt on a smooth surface.

The results confirm that Sobo 20 underestimates the salt quantity when measuring recrystallized brine. Based on the regression curve, one can say that Sobo 20 only detects about 73% of the salt present when it is in the form of recrystallized salt. The measurement deviation seems to increase with the salt quantity.

Great variations in readings were sometimes observed within the same series of measurements (droplets of the same volume). The shape of the droplets in the bottom of bowls seemed to determine the measured quantity, and can determine the recrystallized particle size.

The quantity of salt on road surfaces after application

Measurements of brine and recrystallized salt on asphalt surface

Tests were performed on asphalt surface with both brine and recrystallized salt. The results are shown in Figure 6.8 and Figure 6.9.

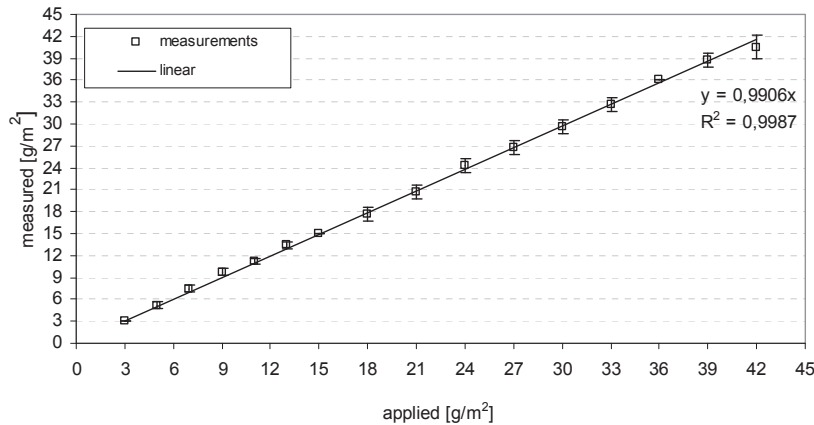

Figure 6.8 Brine on asphalt surface.

Sobo 20 is able to measure brine on asphalt pavement quite accurately with a correlation coefficient close to 1 and the function of the regression curve shows that Sobo 20 measures on average over 99% of the applied salt quantity.

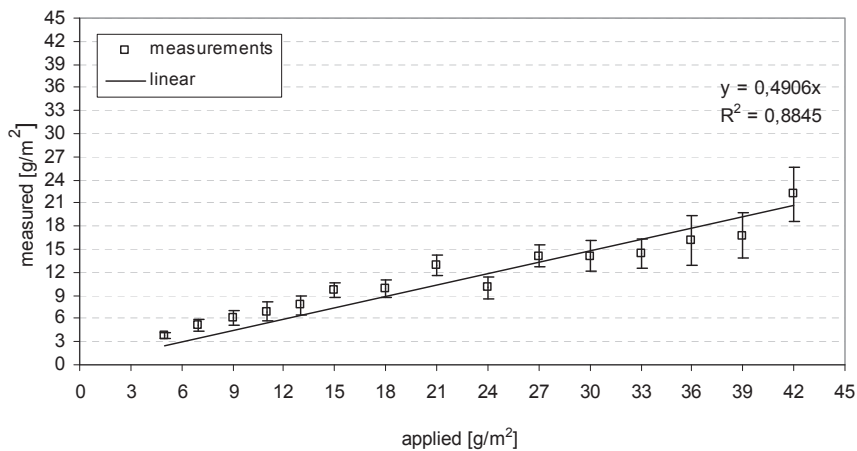

Figure 6.9 Recrystallised salt on asphalt surface.

With recrystallised salt Sobo 20 considerably underestimates the salt quantity on asphalt pavement. While on a smooth surface Sobo 20 detected approximately 73% of the quantity of re-crystallised salt; it detects on average only 49% of the quantity on asphalt pavement. A drop in the measured values was noticed when switching to the 3x scale (from 24 g/m²). Note that there are higher variations in the readings on this test than on the other tests.

6.4.3. Conclusion

The Sobo 20 is still a relevant instrument with its unique features and it is crucial that the limitations and inaccuracies are documented to ensure a correct use and interpretation of the measurements.

From the tests it can be concluded that Sobo 20 does not produce systematic error. It accurately measures the quantity of salt in brine, on both smooth surface and asphalt pavement. However, it only detects between 5 to 6% of dry salt particles. When using the Sobo 20 for the measurement of dry or pre-wetted salt, the displayed value must be interpreted only as the quantity of dissolved salt on the road surface, and not the total salt quantity. The quantity of undissolved salt on a road surface remains unknown, as is the case with other measuring principles.

Re-crystallized salt, made of finer grains, is detected at 58% on smooth surface and 49% on asphalt pavement. It might be relevant to first pre-wet the pavement surface with water, and allow salt to dissolve before doing measurements. The validity of the method is not known, and must therefore be investigated further.

Despite the Danish advice to use only distilled water as measuring fluid, it must be stressed that diverging from the user-guide's recipe for a mixture of 15% acetone and 85% water highly affects the measurements. Using only water will require a recalibration of the instrument.

Although these tests have quantified some essential limitations and documented that the Sobo 20 accurately measures the quantity, there are still some questions remaining. These relate to the small measuring area of the Sobo 20 and the potential natural variation in salt quantity on the road surface. Assuming there is a certain natural variation in salt quantity, this could either be on a larger scale due, for example, to inhomogeneous spreading or salt accumulation due to traffic, or on a small scale due, for example, to small differences in road surface texture. Nevertheless, the question is whether the small measuring area of the Sobo 20 is affected by the natural variation in salt quantity. How many repeating measurements have to be executed to obtain a reliable average for the road surface area one wants to investigate? The number of repetitions will presumably vary depending on the scale or type of area that the measured value should represent, since there will probably be significant differences in natural variation. Obtaining a reliable average value for the quantity of salt on the whole cross section of a road probably requires more repetitions than are needed to obtain a reliable average for the inside of the wheel tracks.

7. RESULTS FROM FIELD OBSERVATIONS

The field observations were carried out during the winter seasons of 2005/2006 and 2006/2007. This chapter presents an overview of all the observations and the data and results these provided.

7.1. An overview of the observations and the available data

During the two seasons 20 periods of field observations were carried out and in addition several more were attempted. Only a few of these periods resulted in complete data sets. A complete data set is defined as one measuring period with one salt application and the following type of information and data available:

- Data on winter maintenance activities including time and rate of salt application
- Measurements of the quantity of salt on the road surface
- Measurements of the quantity of water on the road surface
- Traffic data
- Weather data

The reason that several observation periods did not result in complete data sets are:

- The prevailing weather conditions did not require any salt application during the observation period
- A lack of maintenance data due to failure in the automatic logging system or lack of a manual log by the maintenance crew
- Heavy snowfall made salt measurements with the Sobo 20 impossible

In total, only seven observation periods resulted in complete data sets. In most cases, the north and southbound lanes are salted separately with approximately one hour between the salt applications. When this was the case, each observation period resulted in two data sets, one for the southbound lane and one for the northbound lane. In one observation period, there were also two salt applications with separate salting in each lane. This period therefore produced a total of four data sets. In one case, there was only salting in one lane, resulting in only one data set. Table 7.1 shows the observation periods resulting in complete data sets.

Table 7.1 Observation periods resulting in complete data sets.

Date	Weather	Duration [h]	Salting in both lanes	No. of salt applications	Salting action
07.2.2006	Clear	4,5	Yes	1	30 g/m ² pre-wetted
08.2.2006	Light snow	11,5	Yes	2	30 g/m ² pre-wetted
21.2.2006	Clear	8,5	Yes	1	30 g/m ² pre-wetted
07.3.2006	Light snow, before clear	11	Yes	1	30 g/m ² pre-wetted
24.1.2007	Light clouds, light snow	14	Yes	1	30 g/m ² pre-wetted
31.1.2007	Light clouds	10	Yes	1	30 g/m ² pre-wetted
27.2.2007	Cloudy	8,5	No	1	30 g/m ² pre-wetted

These observation periods gave a total of 15 data sets. During these seven successful observations over 1200 salt measurements were performed with the Sobo 20.

Since the measuring procedure for salt measurements differed in the 2005/2006 and 2006/2007 seasons, the data from the two seasons are not exactly identical.

In the following, results from two observations are shown as examples of the available data.

7.1.1. Example of data from an observation period in 2005/2006

As an example of the data collected, the observation period on 8 February 2006 is shown. The observation had a duration of approximately 12 hours. The weather was cloudy with some periods of light snow. The road surface was in periods partially covered with a little snow, in some periods there was some snow between wheel tracks and in some periods there was only a wet road surface.



The observation point at 09:35.



The observation point at 11:57.



The observation point at 14:06.

Figure 7.1 Pictures of the observation point on 8 February 2006.

During the observation there were four salt applications, two in each lane. At the time of salt application plowing also took place.

Table 7.2 Winter maintenance measures during the observation period.

Time	Lane	Winter maintenance measure
11:16	Southbound	Plowing and salting, 30 g/m ² pre-wetted salt
12:15	Northbound	Plowing and salting, 30 g/m ² pre-wetted salt
17:25	Southbound	Plowing and salting, 30 g/m ² pre-wetted salt
18:10	Northbound	Plowing and salting, 30 g/m ² pre-wetted salt

The quantity of salt on road surfaces after application

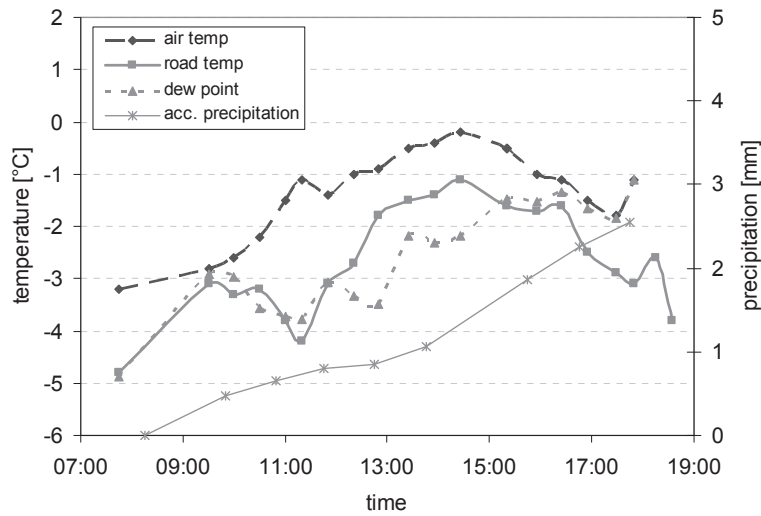

Figure 7.2 The recorded weather data during the observation period.

During the observation approximately 2.5 mm of precipitation was recorded in the form of snow. As shown, there was an increase in both road and air temperature during the period, followed by a decrease at the end of the observation.

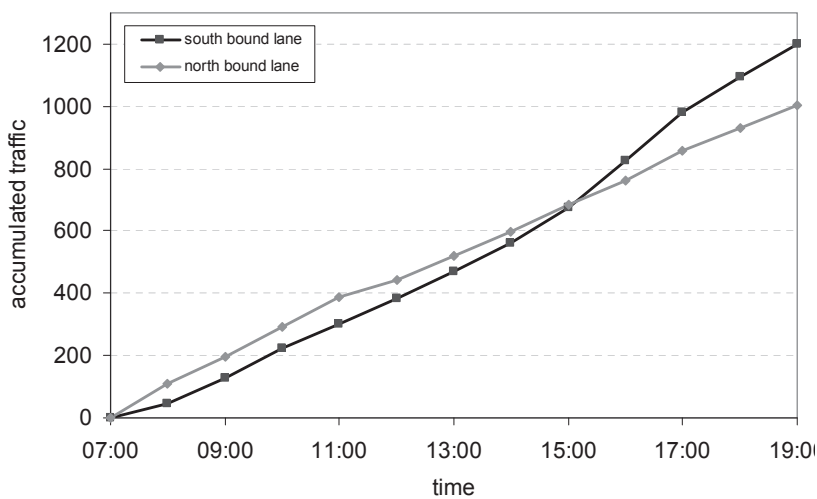

Figure 7.3 The accumulated traffic during the observation period.

As can be seen from Figure 7.3 the traffic is quite stable during the observation period as the time versus traffic curve is fairly linear. In the southbound lane there is some tendency toward a small increase in traffic in the afternoon from approximately 15:00. Since the observation did not start before 07:45, no “rush hour” is recorded in the northbound lane during the observation period.

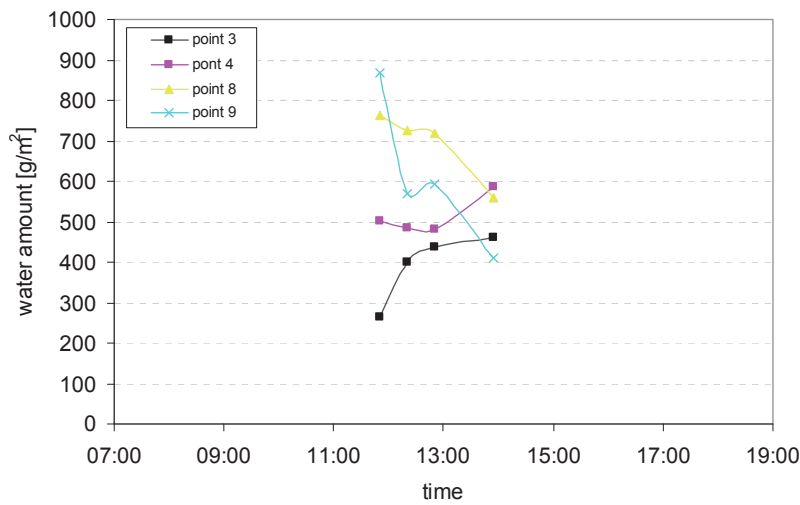

Figure 7.4 The quantity of water on the road surface.

Only a few measurements of the water quantity on the road surface were performed, but the road surface is clearly wet. Measurements were performed both inside and between wheel tracks in the north and southbound lane. As shown, there are great variations both between the measuring points and in time. The northbound lane (points 8 and 9) seems wetter than the southbound lane (defined as points 3 and 4 in Figure 5.6).

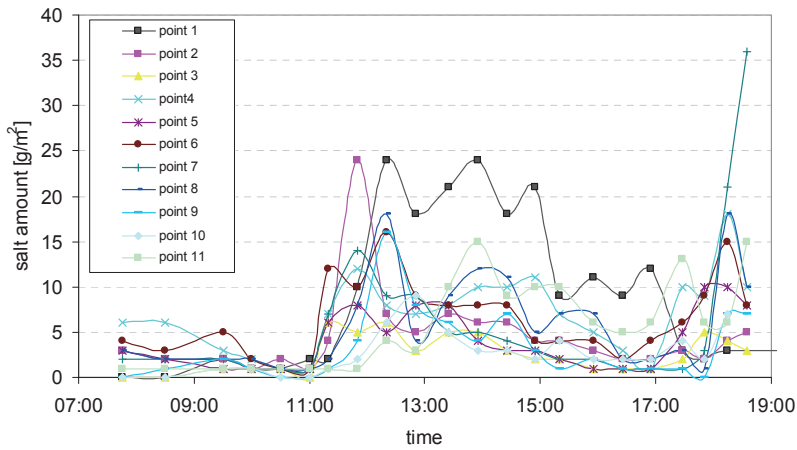

Figure 7.5 The quantity of salt on the road surface.

There is a clear increase in salt quantity on the road surface after the salt application presented in Table 7.2. In the southbound lane, represented by points 1 to 5, there was a salt application at 11:16 and 17:25. In the northbound lane, represented by points 7 to 11, there was a salt application at 12:15 and 18:20.

The quantity of salt on road surfaces after application

7.1.2. Example of data from an observation period in 2006/2007

For the 2006/2007 season, data from 24 January 2007 are shown. The observation period lasted for 14 hours. The weather was cloudy with very light snow that was not recordable. It was quite cold with an air temperature below -12°C at the outset. Although there were scattered ice crystals and snow on the road surface, the road was not slippery.



The observation point at 07:56.



The observation point at 09:20.



The observation point at 14:47.



The observation point at 16:50.

Figure 7.6 Pictures of the observation point on 24 January 2007.

Table 7.3 Winter maintenance measures during the observation period.

Time	Lane	Winter maintenance measure
06:30	Southbound	Plowing and salting, 30 g/m^2 pre-wetted salt
07:39	Northbound	Plowing and salting, 30 g/m^2 pre-wetted salt

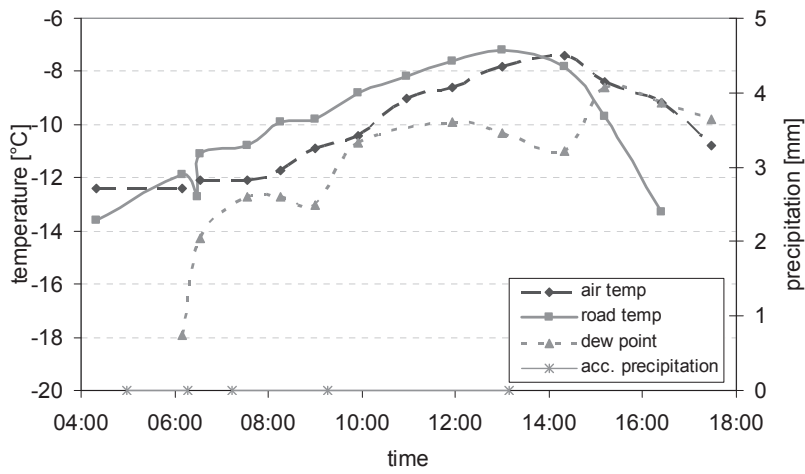

Figure 7.7 The recorded weather data during the observation period.

Although there was some light snow during the observation period, this was so little and light in weight that it was not recordable. It was cold during the day with the lowest air temperature at below -12°C and road surface temperature below -13°C .

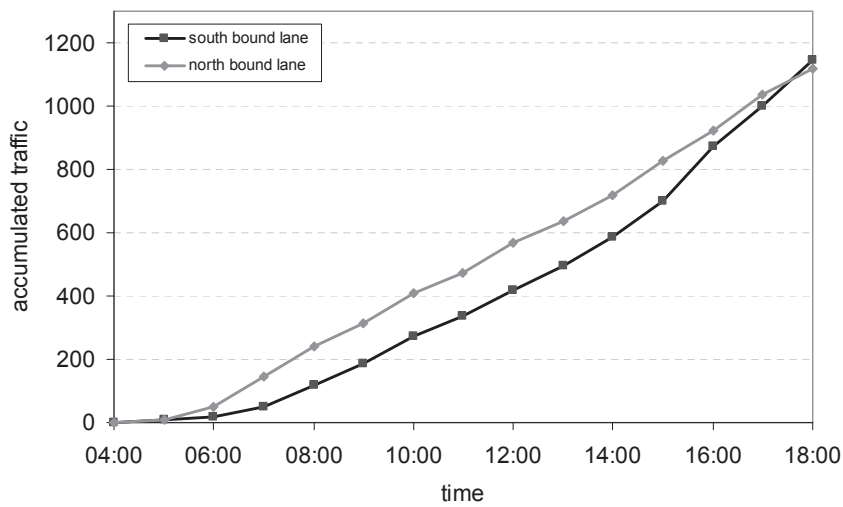

Figure 7.8 The accumulated traffic during the observation period.

The traffic/time curve is also quite linear here with no distinct peak hour traffic. Little traffic could be observed in the first two hours of the observation with some tendency to an increase in traffic in the southbound lane from approximately 15:00.

The quantity of salt on road surfaces after application

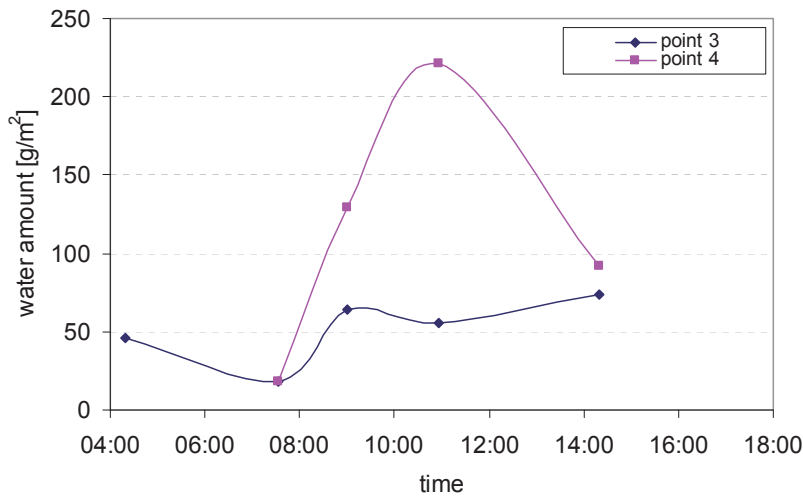

Figure 7.9 The quantity of water on the road surface.

Data on water quantity exist only from the southbound lane at points 3 and 4. There are small quantities of water and the road can be characterized as moist, although between wheel tracks (point 4) the water quantity is above 100 g/m^2 in the middle of the observation period.

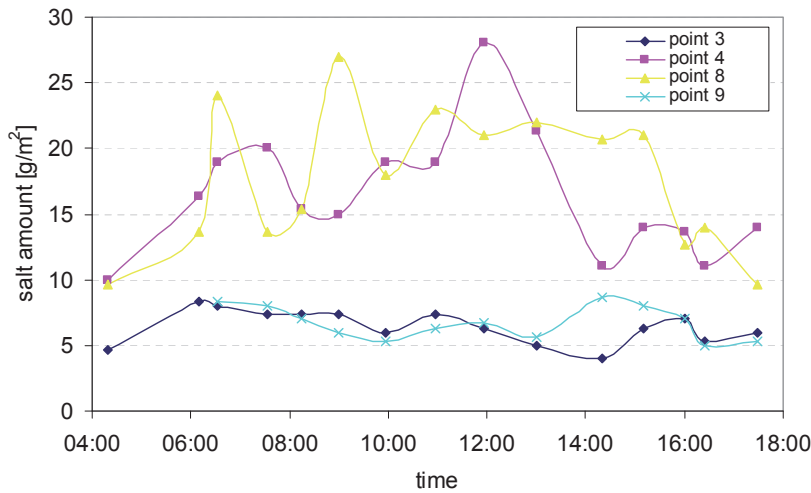

Figure 7.10 The quantity of salt on the road surface.

The salt quantity at points 3, 4, 8, and 9 is shown in Figure 7.10. Each value (data point) is an average of three measurements. Salt application took place at 06:30 in the southbound lane, represented by points 3 and 4, and in the northbound lane at 07:39, represented by points 8 and 9. There is clearly a difference between the salt in wheel tracks (points 3 and 9) and salt between wheel tracks (points 4 and 8). The explanation for this may be that there is more water between wheel tracks, allowing a more rapid dissolution of salt, and the fact that salt gathers between wheel tracks. This dissolution of salt is further discussed in Chapter 8.2.

7.1.3. The use of the data in the papers

Data from all the successful observations are used in the papers. Table 7.4 shows the use of the data from the different observations.

Table 7.4 The use of data from the observations in the papers.

Date	Used in paper	Comments
07.2.2006	IV	All salt measurements used in Paper IV
08.2.2006	IV	All salt measurements used in Paper IV
21.2.2006	IV	All salt measurements used in Paper IV
07.3.2006	III and IV	Southbound lane as case in Paper III, all salt measurements used in Paper IV
24.1.2007	II	Southbound lane as case Paper II, all salt measurements used in Paper IV
31.1.2007	II, III and IV	Both lanes as Paper II, north lane in paper III, all salt measurements used in Paper IV
27.2.2007	II and IV	Southbound lane as case Paper II, all salt measurements used in Paper IV

For the observation on 31 January 2007 the salt quantity inside the wheel tracks in the northbound lane is used twice as a case in Papers II and III. For the observation on 24 January 2007 the salt quantity in wheel tracks is shown in both Paper III and as an example in Chapter 7.1.2.

7.2. Salt on road surface after application

It is meaningful to talk about both spatial and timely distribution of salt on the road surface after application. This is illustrated in the following chapters.

7.2.1. The spatial distribution of salt

As stated in Chapter 5.2 it was assumed that the salt quantity would be fairly evenly distributed in the longitudinal direction of the road. It was assumed that the traffic would quite quickly level out any differences in the longitudinal distribution of salt. As a consequence it was chosen to do only one salt measurement in each of eleven predefined points in the cross profile for the first season (2005/2006) of field observations. In observing the data from the first season it was quite obvious that this assumption was not entirely correct. Plotting the quantity as a function of time for each point, as shown in Figure 7.5, produced quite uneven curves. This also indicated spatial variation in the longitudinal direction. As mentioned, the measuring procedure was altered for the second observation season so that there were only four measuring points in the cross profile but three repeating measurements at these points.

Variation in the longitudinal direction

To illustrate the variation in salt quantity in the longitudinal direction, the data for the 2006/2007 season can be used. For each point in the cross profile three repeating measurements were performed. The variation in these three measurements can be calculated. Here the deviation from the average value was selected. The average from the measurements was calculated and for each of the three measurements the deviation from the average was then calculated.

The quantity of salt on road surfaces after application

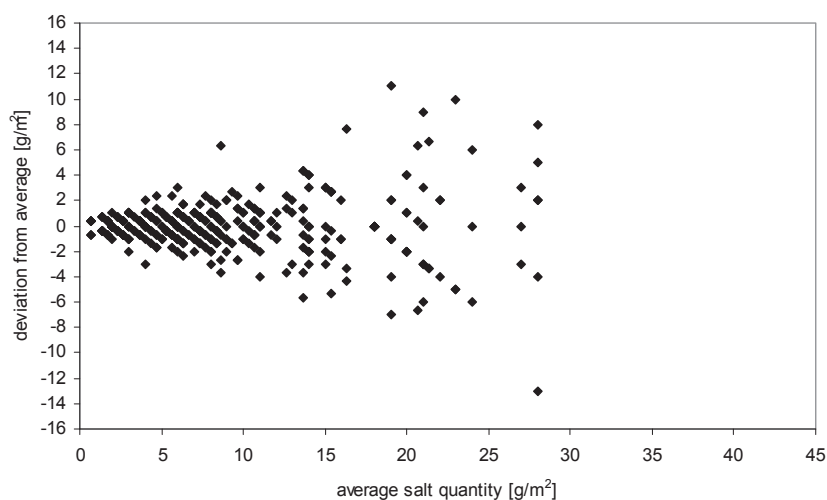

Figure 7.11 The deviation from the average value plotted against the average salt quantity for all measurements in 2006/2007. Measurements conducted in right wheel tracks and between wheel tracks in both lanes (points 3, 4, 8 and 9).

In Figure 7.11 the deviation from the average is plotted against the average value and naturally the actual value of the deviation increases with increasing salt quantities. If there are high quantities of salt on the road surface the variation expressed in actual value is also greater.

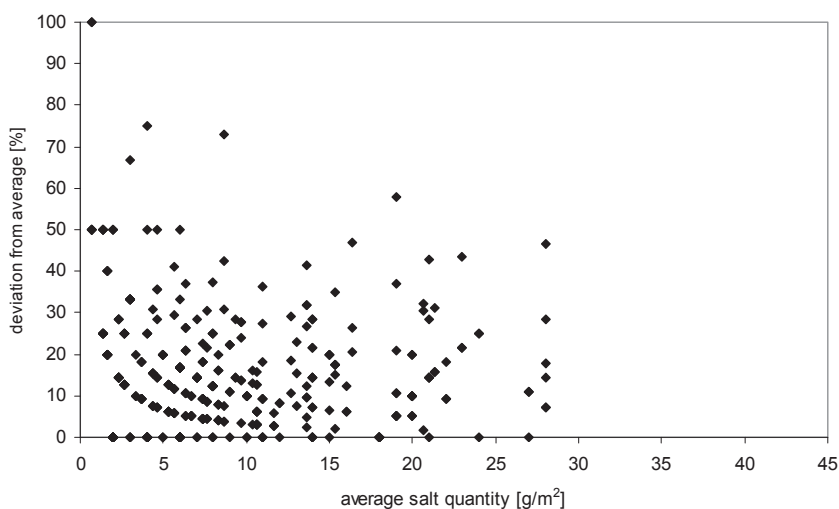

Figure 7.12 The relative deviation from average plotted against average salt quantity.

The relative variation is found by calculating the deviation in percentage of the average. As shown in Figure 7.12 the relative variation is not greater at high salt quantities than at low salt quantities. But as shown in the figure the relative variation is substantial for both high and low salt quantities. Approximately 73% of the measurements have a deviation from the average of 20% or less.

It was assumed that the spatial variation in the longitudinal direction would decrease after application due to the effect of traffic leveling it out. To test if that was true the data on deviation from the repeating measurements were plotted against traffic.

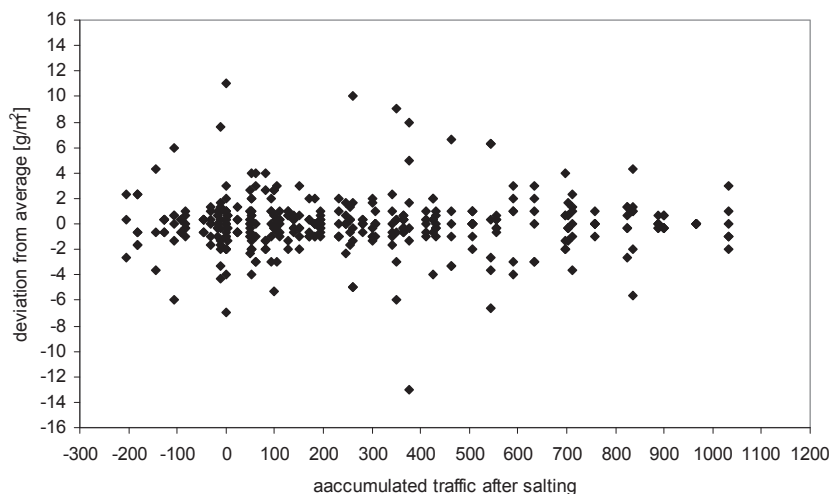

Figure 7.13 The deviation from the average plotted against traffic.

Plotting the actual value of the deviation, it seems that the variation is smaller as the road is trafficked after application. At the same time it is known that the salt quantity itself is decreasing and as shown in Figure 7.11 a lower salt quantity means a lower variation in actual value. So the seeming tendency toward decreasing variation as the road is trafficked is just an expression of the decreasing salt quantity as the road is trafficked.

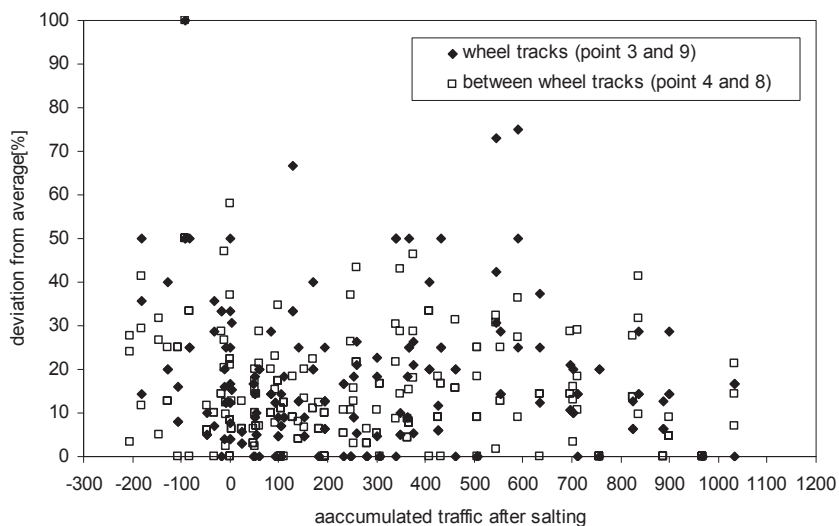

Figure 7.14 Relative deviation from average plotted against traffic.

By plotting the relative deviation from the average it is shown that the variation in the measurements does not decrease as the road surface is influenced by traffic.

The quantity of salt on road surfaces after application

It could also be assumed that there is less variation inside wheel tracks than between wheel tracks. To investigate this, the deviation of the measurements inside wheel tracks is plotted (corresponding to points 3 and 9) and the deviation between wheel tracks (points 4 and 8) is plotted separately. Generally, the salt quantity inside wheel tracks is lower than between wheel tracks, which means that the deviation in actual values is less inside wheel tracks than between wheel tracks. Looking at the relative deviation, the variation in the measurements can be said to be at the same level inside wheel tracks as between wheel tracks.

Spatial variation in the cross profile

Due to the effect of traffic it is obvious that there will be substantial spatial variation in the salt quantity in the cross profile of the road. This is also clearly shown by Blomqvist and Gustafsson (2004). They have shown that higher quantities of salt on road edges, between wheel tracks and in the centre of the road were recorded than in wheel tracks. Blomqvist and Gustafsson interpret this as being caused by salt gathering in these areas.

The results from the observations conducted in this study also show higher salt quantities on road edges, between wheel tracks and at the centre of the road than in wheel tracks. It is also shown that these differences appear relatively quickly after salt application. To illustrate this, some selected measurements in the cross profile from two field observations from 2005/2006 are shown. The measuring points from 1 to 11 are plotted according to their placement in relation to the centre line.

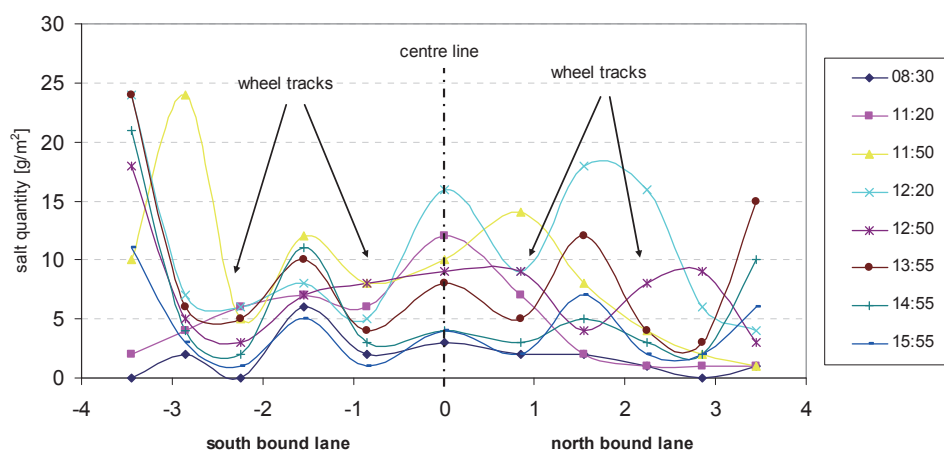

Figure 7.15 Salt quantity in the cross profile of the road from the observation of 8 February 2006.

Figure 7.15 shows results from the observation of 8 February 2006. The different curves represent measurements at different times. Salt application took place at 11:16 in the southbound lane and at 12:15 in the northbound lane.

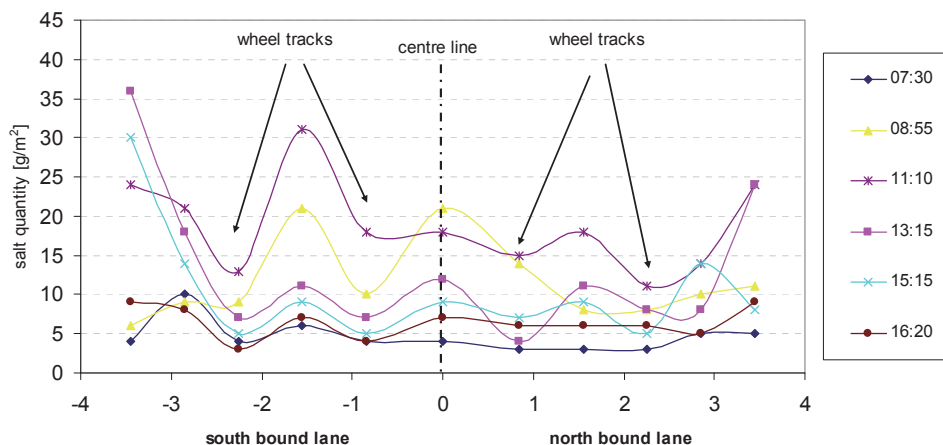

Figure 7.16 Salt quantity in the cross profile of the road from the observation of 7 March 2006.

Figure 7.16 shows results from the observation of 7 March 2006. Salt application was conducted at 08:07 in the southbound lane and at 08:50 in the northbound lane.

Although there is some scatter in the data, it is clearly shown from the two cases that there are higher salt quantities at the points located at the road's edge, between wheel tracks and at the centre line than inside wheel tracks. It is also noticeable that this happens relatively soon after application. As mentioned, the reason for obtaining higher quantities at road edge, middle of road and between wheel tracks is likely to be the redistribution and accumulation of salt from wheel tracks. In addition it is also likely that higher quantities of water at road edge, middle of road and between wheel tracks give a higher rate of dissolution of salt and thereby higher salt quantities in these areas.

The higher salt quantities between wheel tracks than inside wheel tracks is also illustrated by plotting the measurements of the salt quantities at the different points in the cross profile as a function of time, as shown in Figure 7.17.

The quantity of salt on road surfaces after application

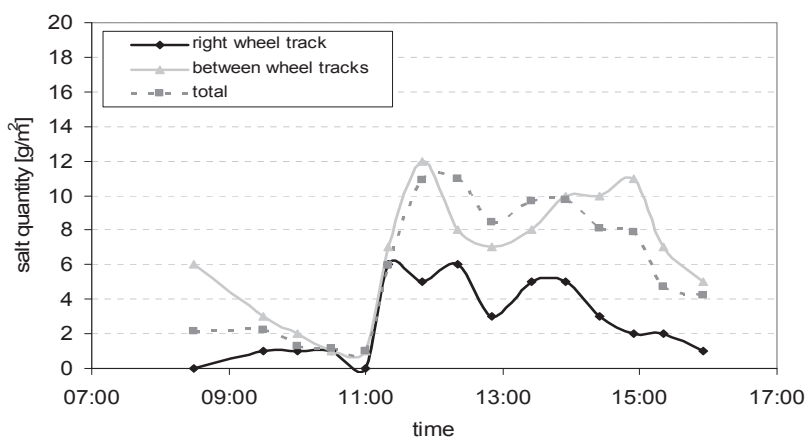

Figure 7.17 The salt quantity in the right wheel track, between wheel tracks and calculated total salt quantity in southbound lane on 8 February 2006.

The total quantity of salt in the lane is calculated by calculating the area beneath the graphs shown in Figure 7.15. As seen, the maximum salt quantity between wheel tracks is almost twice the quantity inside wheel tracks.

7.2.2. The salt quantity as a function of time or traffic

The salt quantity on the road surface can be plotted either as a function of time or traffic. As an example of the collected data shown in Chapter 7.1, salt quantity, together with data on water quantity, weather and traffic are plotted as a function of time (Figure 7.5, Figure 7.10 and Figure 7.17). In Papers II and III the processes that control the change in salt quantity and the mechanisms of loss of salt from the road are discussed. A summary of this discussion is also presented in Chapter 8. One of the conclusions from this discussion is that traffic is an important driving force for the processes that control the quantity of salt on road surfaces. Based on this it seems reasonable in most cases to plot salt quantity as a function of traffic. It is also important to emphasize that if the traffic is fairly linear in relation to time, there will not be great differences in the salt quantity – time curve versus salt quantity – traffic curve.

To further examine the changes in salt quantity as a function of time or traffic, it has been chosen to focus mainly on the salt quantity in wheel tracks. For the analysis it has been desirable to be able to focus on one or few points in the cross profile. When changing the measuring procedure for the second season, to be able to perform repeating measurements, it was also necessary to focus on fewer points in the cross profile. Two arguments can be presented for focusing on the salt quantity in wheel tracks. Firstly, both from Blomqvist and Gustafsson (2004) and this study it is shown that salt in wheel tracks diminishes more quickly than in any other place in the cross profile and that makes the wheel tracks most critical. Secondly, it can be added that the road surface conditions in wheel tracks are most important for driving conditions and therefore that the salt quantity in wheel tracks is most significant.

The salt quantity inside wheel tracks as a function of traffic is shown for several cases of observations in Papers II, III and IV. From figures showing salt quantity as a function of time as presented in 7.1 and as a function of traffic in the papers, a distinct pattern for the changes in salt quantity appears. The pattern can be presented schematically as shown in Figure 7.18.

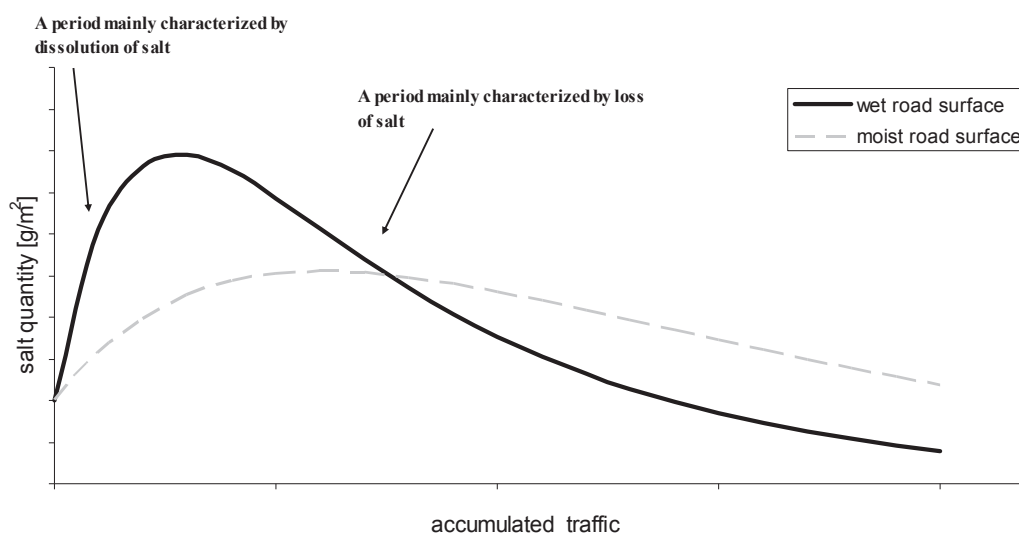

Figure 7.18 Idealized curves describing the salt quantity after application for wet and moist road surfaces.

Based on the results from the field observations and the idealized curve presented for the salt quantity after application, some main findings can be stated:

- The salt quantity after application (measured with Sobo 20) cannot be described by a simple linear or exponential decrease in salt quantity. Shortly after application there is an increase in the measured salt quantity, thereafter followed by a decrease in salt quantity.
- Generally, there can be said to be a surprisingly rapid decay in salt quantity in all observations.
- The decay is substantially more rapid on wet road surfaces than on moist road surfaces. Wet and moist road surfaces show substantial differences in the quantity of salt after salt application. Wet road surfaces generally have a rapid increase, high maximum values and a rapid decay in salt quantity. Moist road surfaces generally show a slower increase, lower maximum values and a slower decay in salt quantity than wet road surfaces.
- The quantity of water seems to be one of the main factors influencing the quantity of the measured salt on road surfaces.

8. PROCESSES THAT CONTROL THE QUANTITY OF SALT ON ROAD SURFACES AFTER APPLICATION

The idealized curves for the salt quantity after application presented in Figure 7.18 can be said to consist of two different periods: one period mainly characterized by dissolution of salt and one mainly by loss of salt. The behavior shown in Figure 7.18 can be explained by a combination of the spreading method, measuring instrument, the measuring procedure and the processes that control the quantity of salt after application. When spreading dry or pre-wetted salt, undissolved salt will be present on the road surface. Since the Sobo 20 only detects dissolved salt or at least only partly measures undissolved salt, the quantity of measured salt will increase until all of the spread material is dissolved. To detect the increase in salt quantity, measurements have to be taken immediately after application and thereafter at short intervals.

Based on the results from the field observations and the following main findings, it is proposed that the quantity of salt on road surfaces after application is controlled by three different processes:

1. The initial loss of salt
2. The dissolution of salt
3. The loss of salt

While the initial loss can be stated to be a momentary process, the dissolution and loss of salt can be stated to be time or traffic-dependent processes.

The idealized curve presented in Figure 7.18 can be described by the initial conditions, the initial loss and two different functions describing the dissolution and loss of salt. This is illustrated in Figure 8.1.

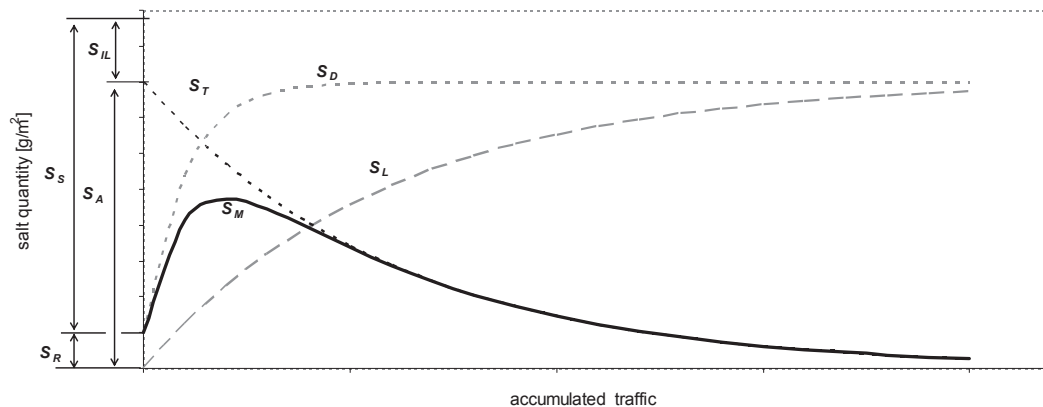

Figure 8.1: The salt quantity on road surfaces after application and the different processes controlling the quantity.

Where the initial conditions are described by:

- S_S : Quantity of salt spread [g/m^2]
- S_R : Residual salt (at time of spreading)
- S_{IL} : Initial salt loss during spreading [g/m^2]

The two functions describing the changes in salt quantity on road surfaces are:

- S_D : Theoretical quantity of dissolved salt (with no loss) [g/m^2]
- S_L : Accumulated quantity of salt lost from road surface [g/m^2]

The following relationship can be derived:

$$S_M = S_D - S_L \quad (8.1)$$

Where:

$$S_M = \text{Measured salt with Sobo 20 [g/m}^2\text{]}$$

and

$$S_T = (S_s + S_R - S_{LL}) - S_L = S_A - S_L \quad (8.2)$$

Where:

$$S_T = \text{Total quantity of salt on the road surface [g/m}^2\text{]}$$

$$S_A = \text{Available salt on the road surface after spreading [g/m}^2\text{]}$$

Note that the definition of the S_A in Figure 8.1 is different from the definition presented in Paper III. In Figure 8.1 the quantity of available salt on the road surface, S_A also includes the quantity of residual salt, S_R . In the corresponding figure in Paper III the S_R is not included in S_A . The presentation of the figure made in the paper is in fact not entirely correct according to the derivation of equations shown later for the different loss processes, see chapter 8.3.4.

The different processes shown in Figure 8.1 are presented and discussed in the following chapters.

8.1. The initial loss

The initial loss, as the name indicates, is salt loss that occurs at the time of spreading. It can be said to be salt that never ends up on the road surface at any time. (Klein-Paste, 2008b) states that initial loss can be caused by: 1) wind and turbulence from the spreading vehicle which makes the salt blow away, or 2) from salt grains bouncing and scattering off the road surface when they hit the pavement. It is likely that initial loss is dependent on:

- Spreading method (dry, pre-wetted or brine)
- Performance/execution of spreading:
 - Spreading speed
 - Spreading width
- Road surface conditions - the wetness of the road and presence of ice or snow
- Road surface texture
- Wind

The initial loss is described in Paper II.

8.2. The dissolution process

The dissolution process is the process where dry salt or salt grains dissolve in the water or brine present on the road surfaces. Salt has to be dissolved on the road surface to be able to perform according to the mechanisms described in Chapter 3.1. As described in Chapter 3.2.1 and 3.4.1, the freezing point of water and melting of ice are dependent on the quantity of dissolved salt. There are two important factors describing the dissolution process: the solubility of a chemical and the dissolution rate.

8.2.1. The solubility

The solubility of a chemical is defined as the maximum quantity of a solute that can be dissolved in a certain quantity of solvent. In the salting of roads, the solute is salt, in most cases sodium chloride, and water is the solvent. Different chemicals have different solubility in water. For most chemicals the solubility increases with increasing temperatures. According to (Mullin J.W., 2001) the solubility of sodium chloride in water is one of the well known exceptions, as the solubility only shows a slight increase with temperature. The solubility curve can be shown together with the freezing point in a so-called phase diagram, as shown in Figure 3.2, or only as a plot of the solubility as a function of temperature.

The solubility will determine the maximum quantity of salt that can theoretically be dissolved in the water quantity that is present on the road surfaces. A solubility of 26.3% mass at 0° C for sodium chloride means that 2.8 times more water than salt is required on the road surface for the salt to fully dissolve. An application rate of 30 g/m² requires more than 84 g/m² of water for the salt to be able to fully dissolve. If salt is dissolved on the road surface and the roads dry up, water will evaporate and result in a higher concentration. When the concentration reaches the saturation point, recrystallization of salt will occur.

8.2.2. The dissolution rate

The dissolution rate, R_D , expresses how quickly the solute will dissolve. As for the solubility, the dissolution rate is determined by the nature of the solute and the solvent. The driving force for the dissolution process is the concentration difference (undersaturation) and the dissolution rate, R_D , can be expressed as a function of the degree of undersaturation (Mullin, 2001):

$$R_D = K_D \Delta C = K_D (C^* - C) \quad (8.3)$$

Where:

- K_D : = Dissolution mass transfer coefficient
- ΔC = Degree of undersaturation (the driving force)
- C = Solution concentration
- C^* = Equilibrium saturation at the given temperature

In addition the dissolution rate is dependent on the following:

- Temperature
- Interfacial surface area (area of solids)
- Presence of mixing

(Mullin, 2001), (Wang and Flanagan, 2009)

The dissolution rate increases with increasing temperature. The dissolution rate will also increase with an increase in the interfacial surface area. A solute with small particles has a greater area of solids per unit mass than a solute with larger particle size. That means that fine graded salt dissolves more rapidly than salt with larger particle size. Mixing will increase the dissolution rate as it mechanically ensures that there are maximum concentration differences in the vicinity of undissolved salt. The dissolution rate is more thoroughly described in Paper III.

8.2.3. Describing the quantity of dissolved salt on the road surface

A function describing the quantity of dissolved salt is found by solving the differential equation describing the relationship between the dissolution rate and the degree of undersaturation:

$$R_D = C' = \frac{dC}{dt} = K_D(C^* - C) \quad (8.4)$$

Where $\frac{dC}{dt} = C'$ is the dissolution rate and the time derivative of the quantity of dissolved salt.

By assuming that $C = 0$ for time, $t = 0$ and that $C = C^*$ for $t = \infty$, one solves for C yielding:

$$C = C^*(1 - e^{-K_D t}) \quad (8.5)$$

Assuming also that there is residual salt (S_R) present at the time of application, as shown in Figure 8.1, the quantity of dissolved salt on a unit area after application is therefore described by:

$$S_D = S_R + C^*(1 - e^{-K_D t}) \cdot W \quad (8.6)$$

Where:

W = Quantity of water on the road surface

Assuming that traffic (Tr) is linearly proportional to time, the traffic can be written as:

$$Tr = m \cdot t \quad (8.7)$$

Where:

Tr = Accumulated traffic

t = Time after salting

m = Describing the relationship between time and traffic

Thus, the theoretical quantity of dissolved salt can be written as:

$$S_D = S_R + C^*(1 - e^{-\frac{K_D Tr}{m}}) \cdot W \quad (8.8)$$

It is important to note that in Paper III the residual salt, S_R , is not included in the equation describing the quantity of dissolved salt (Equation 8.8). If there is salt on the road surface present at the time of salt application, this should be included in the equation. Also notice that in the equation in Paper III the proportional constant, m , describing the relationship between time and traffic, is not taken into account in the equation for the quantity of dissolved salt.

The plot of the quantity of dissolved salt as a function of traffic will therefore follow an exponential curve with an asymptotic value representing the quantity of salt given at the saturation point. In Figure 8.1, the quantity of dissolved salt consistently follows an exponential curve, where the asymptotic point represents the quantity of available salt on the road surface, S_A . Whether such a presentation is correct will be determined by the quantity of

The quantity of salt on road surfaces after application

water on the road surface. Such development, as shown in Figure 8.1, will only be correct if the quantity of water is exactly sufficient for the quantity of salt to be dissolved and reach the saturation point. According to the solubility curve for sodium chloride, this means that 2.8 times more water than salt is necessary at a temperature of 0° C. As illustrated by Curve 2 in Figure 8.2, this exact ratio between the quantity of salt and water will theoretically allow all the salt to be dissolved. Therefore, the degree of undersaturation (rate of dissolution) will approach zero at the end of the dissolution process.

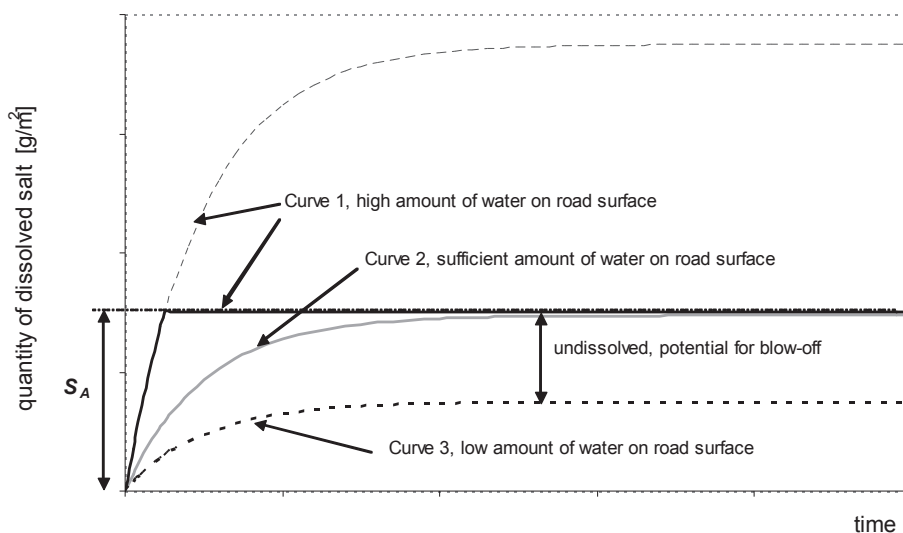

Figure 8.2 The quantity of dissolved salt on road surfaces with different quantities of water.

Theoretically, a high quantity of water on a road surface will allow more salt to dissolve than the available quantity of salt. Therefore, the dissolution curve will follow an exponential curve with a higher asymptotic point than the available quantity of salt, until all the salt is dissolved. This means that the dissolution curve will only follow the exponential curve until all the available salt is dissolved. Curve 1 in Figure 8.2 illustrates such a case. If too small a quantity of water is available, the available salt will not dissolve as the saturation point is reached. As shown by Curve 3 in Figure 8.2, the curve describing the quantity of dissolved salt will follow an exponential function, with the asymptotic point representing the saturation point and being below the value of available salt.

Based on this discussion it is reasonable to assume that the dissolution of salt on the road surface can be described by an exponential function.

8.3. The loss of salt after application

The last process identified to control the quantity of salt on road surfaces is the loss of salt. Three different mechanisms can be identified that remove salt from the road surface:

1. Blow-off
2. Spray-off
3. Run-off

The three mechanisms are briefly presented in the following chapters.

8.3.1. Blow-off

Blow-off is defined as solid salt grains being removed off the road. Blow-off is caused by traffic and it will thus be a function of the number of passing vehicles. It is likely that blow-off is dependent on the type of vehicles and traffic speed, in addition to road surface conditions, pavement texture and wind.

8.3.2. Spray-off

Spray-off is dissolved salt that is removed from the road surface. Like blow-off, spray-off is also caused by traffic and will be a function of traffic. The mechanism is dependent on the type of vehicles, traffic speed, quantity of water on the road surface, wind and surface texture.

8.3.3. Run-off

Run-off is salt that is removed by gravity-driven drainage as liquid from the road surface. Run-off will probably only start when there is a critical quantity of water on the road surface. The systems of pores on the pavement probably have to be “saturated” before run-off occurs. The critical value can be seen as a threshold-value. The mechanism is controlled by precipitation or melting of snow and it is likely that both the threshold-value and flux will be influenced by road surface texture, cross-fall and rutting.

Table 8.1 The loss mechanisms that remove salt from road surfaces after salt application and important factors influencing the mechanisms.

Mechanism	Weather	Traffic	Road characteristics
Blow-off	Wind Quantity of water on road surface - precipitation	Volume Speed Vehicle type	Texture
Spray-off	Wind Quantity of water on road surface - precipitation	Volume Speed Vehicle type	Texture Rutting
Run-off	Quantity of water on road surface - precipitation		Texture Rutting Cross-fall

8.3.4. Describing the quantity of the salt loss

Salt loss due to traffic either as blow-off or spray-off is probably mainly dependent on the quantity of dry salt or water present on the road. A reasonable assumption may be that the loss of salt caused by each vehicle is a certain portion, K_L , of the existing salt on the road. Assuming that K_L is the same for all vehicles, and that K_L includes both the loss of salt due to blow-off and spray-off, S_L . after n vehicles is written as shown in Equation 8.9:

$$S_L = S_A [1 - (1 - K_L)^n] \quad (8.9)$$

Therefore, the general expression for the total salt loss as a function of traffic is shown in Equation 8.10:

$$\Rightarrow S_L = S_A [1 - e^{\ln(1-K_L)Tr}] \quad (8.10)$$

The curve describing the accumulated loss due to blow-off and spray-off of salt will therefore follow an exponential curve.

The quantity of salt on road surfaces after application

It is important to note that the loss of salt due to blow-off and spray-off are actually dependent on several factors. That means that the K_L -value in Equation 8.10 will be dependent on parameters such as vehicle type, traffic speed, road surface characteristics and weather. The different factors affecting spray-off and blow-off and thereby the k -value are presented in Table 8.1.

According to the discussion in chapter 8.3.3 and in Paper III, run-off only occurs when there is a critical quantity of water on the road surface. In the observations presented in the thesis there was no noticeable run-off from the road surface. On that basis, there is further assumed to be no contribution by run-off to the total loss of salt. The loss of salt due to plowing is not taken into account in Equation 8.10. In cases of continuous snowfall, plowing will result in a sudden loss of salt and thereby a discontinuity in the function describing the loss of salt.

From these arguments it can be stated that the loss mechanisms of both spray-off and run-off will follow exponential curves, and as a result the curve describing total loss will also have an exponential shape.

Kai Rune Lysbakken

9. A PHYSICAL- BASED MODEL FOR SALT QUANTITY ON ROAD SURFACES AFTER APPLICATION

Based on the discussion of the processes presented in Chapter 8, a model for describing the quantity of salt measured with the Sobo 20 can be proposed. By combining the two functions describing the dissolution and the loss of salt an equation for the quantity of measured salt is found. The model is presented in Equation 9.1:

$$S_M = S_D - S_L = S_R + C * (1 - e^{-\frac{K_D T_r}{m}}) \cdot W - S_A [1 - e^{\ln(1-K_L) T_r}] \quad (9.1)$$

$(S_D \leq S_A)$

A model is not a complete and entirely correct presentation of reality. The model presented here is therefore naturally based on several simplifications and assumptions. The most important simplification is that the salt dissolution and loss have been seen as independent processes and are also presented mathematically as such. In reality, however, these processes are not independent. The dissolution of salt affects the salt-loss process and vice versa. The dissolution process will affect the loss rate and determine which of the loss mechanisms is dominant. Consider an example where dry salt is spread on a road surface where there is a small quantity of water. The dissolution process will then be very slow and there will be a large quantity of undissolved salt potentially exposed to being blown off the road by traffic, see Figure 8.2. For this reason the blow-off loss mechanism will be dominant. On the other hand, if the road surface is wet, the dissolution process will be more rapid. In this case there will be less blow-off, but the spray-off effect will be increased. According to the relationship between salt dissolution and salt loss, the curve in Figure 8.1 describing salt loss should be discontinuous and should have a breaking point when the dissolution process is complete. When all the salt is dissolved, the salt-loss process is purely due to the spray-off mechanism. In that respect the process of salt loss could be presented more correctly as a sum of two different functions, one describing blow-off and the other describing spray-off. However, the lack of instruments that fully measure undissolved salt makes it impossible to produce data to separate and quantify the two loss processes.

In the model the dissolution process is presented as a function of traffic made possible by the assumption that there is a linear relationship between time and traffic. This is clearly a simplification that can be problematic. Very often there can be a great variation in traffic during a 24 hour period because of rush-hour traffic. It is then incorrect to assume a linear relationship between time and traffic. In reality, the dissolution process in itself is time-dependent with the exception that traffic will provide a grinding of salt grains and mixing that will speed up the process.

As mentioned earlier in chapter 8.3.4, no loss due to run-off is assumed in the model. The assumption is based on a visual assessment of no contribution due to salt loss in the field observation presented here. Whether this is a correct assumption is certainly open to discussion, and the assumption is not supported by measurements. If there are substantial quantities of water on the road surface, the quantity of salt loss will be underestimated, or rather the loss due to run-off will constitute part of the equation describing the loss due to spray-off and blow-off.

The initial loss of salt is not calculated by the model, but is rather just an input parameter. The initial loss is taken into account in the term *available salt*, S_A , as shown in Figure 8.1. The available salt, S_A , is defined as the quantity of salt spread plus the quantity of residual salt minus the initial loss. The initial loss has to be measured, assumed or may be possible to calculate in a regression analysis by using the model on field data. As mentioned before, the lack of instruments that fully measure undissolved salt makes it difficult to quantify the initial loss for the spreading of dry or pre-wetted salt.

9.1. The use of the model on data from field observations

By means of regression analyses the model is adapted to data from the field observations. In Paper III the model is used on data from two different field observations and in Paper IV the model is used on data from the southbound lane from all field observations combined. The observations are divided into cases with wet and moist road surfaces according to Table 5.1.

The regression analysis is carried out using the “*least squares method*” and the “*Problem solver*” in Excel. It is important to emphasize that although the model is physically based, the output (coefficients) from regression analysis should not be interpreted as physical constants. For the regression analysis certain assumptions have to be made. Some input variables in the model have to be assumed. This is either because the input cannot be measured, like the quantity of initial loss, or since several cases are combined to one data set, an assessment of common input values has to be made. The aim of the physically based model has been to show which physical processes determine the quantity of salt after application, to make it probable what type of functions can describe the processes, and finally which factors influence these processes.

To distinguish between the physical model and the output of the regression analyses, the denotation for the variables describing the rate of dissolution and rate of salt are a change from capital letters in the physically based model to lower-case letters in the regression analysis. The variables k_D and k_L , describing the rate of dissolution and rate of salt respectively, are calculated by regression. Data from all observations for salt quantity in wheel tracks measured in wheel tracks in the southbound lane are used in the regression analysis. The observations are divided into cases with wet and moist road surfaces.

In Papers III and IV as the quantity of residual salt was not incorporated into the equation, the quantity of residual salt was also assumed to be zero in the calculation. This assumption is certainly open to discussion as it is not very likely that there is no initial loss of salt. Because of the revised equation and assumption regarding the initial loss, a new regression analysis is presented here. The input parameters for the regression analysis are presented in Table 9.1.

Table 9.1 The input parameters for the model in the regression analysis.

Input	Wet road surface [g/m ²]	Moist road surface [g/m ²]
Spread salt, S_S	30	30
Initial loss, S_{IL}	5	5
Residual salt, S_R	3	5
Quantity of water on road surface, W	200	84

As mentioned earlier the spreading rate was the same during all the field observations. The quantity of initial loss was assumed be the same. It was assumed there would be less residual salt on a wet road than on a moist road surface due to higher loss. For a moist road surface it

The quantity of salt on road surfaces after application

was assumed that there was sufficient water quantity to dissolve the quantity of available salt, S_A .

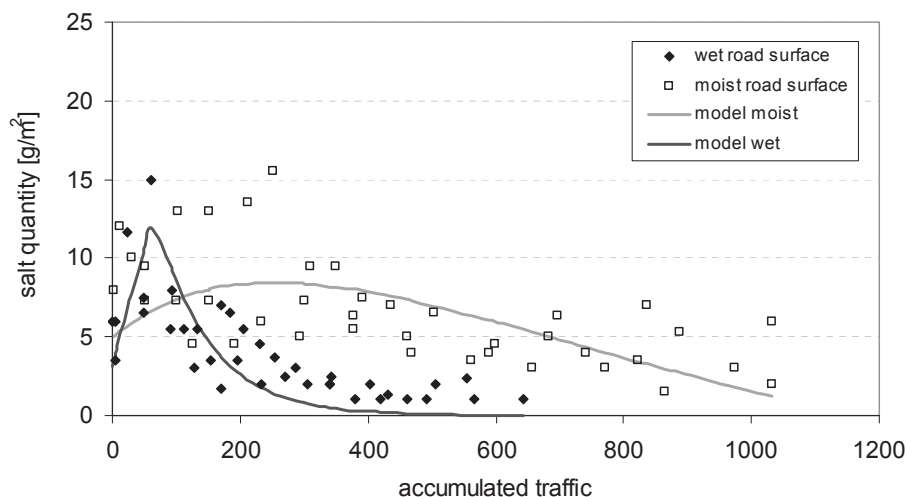

Figure 9.1 Data from lane 1 from all field observations and the model for the quantity of measured salt.

As shown in Figure 9.1, the regression analysis results in a model describing both higher dissolution and higher loss rate on wet road surfaces than on moist road surfaces, as indicated in the data. This confirms that the model can be used to explain the quantity of measured salt on road surfaces after application, and the identified processes of salt dissolution and loss control the quantity of salt after application. Further, this confirms that the water quantity is a very important factor in determining the quantity of salt after application

Table 9.2 The output from the regression analysis

Output	Wet road surface	Moist road surface
The salt dissolution factor, k_D	0,0096	0,0035
The salt loss factor, k_L	0,0118	0,0012

As can be seen from Table 9.2, the regression analysis results in a salt-loss factor that is substantially higher on wet road surface than on moist road surfaces. When it comes to the salt dissolution factor, this is also higher on wet road surface than on moist road surface. It is correct that there should be a more rapid dissolution on wet road surface than on moist. Nevertheless, looking back to the physical understanding of the dissolution mass transfer coefficient (K_D) in the model, this coefficient should have been the same. The dissolution mass transfer coefficient (K_D) is not depended on the water quantity of the road surface, but rather on the nature of the solvent (type of chemical) and other physical parameters like temperature, mixing and areas of solid (see Chapter 8.2.2). The higher dissolution rate on wet road surface should according to the physically based model only be dependent on the quantity of water on the road surface, W (see chapter 8.2.2). It is therefore important to distinguish between the physical defined constant in the model and the dissolution rate constant found in the regression analyses. Certain assumptions made both in the derivation of the physical model and for the purposes of the regression analyses make it essential to distinguish between the model coefficient and output of the regression. An example of such a simplification is the assumption of a linear relationship between time and traffic and thereby the possibility of describing the dissolution of salt as a function of traffic. Another is the fact

that the data set consists of different observations which in reality all had different quantities of water and residual salt.

Although the model produced is satisfactory according to the data, it is at this stage not suitable for using for decision-making purposes. This is due to large data scatter and low data quality together with a need for a further development of the model.

9.2. Further development of the model

The physical model can be developed further by an additional investigation and deconstructing of the individual processes. In particular there is potential for a further study of the different loss mechanisms. The possibility of dividing the loss mechanism into separate physically based models or equations should be investigated. Nevertheless, developing separate expressions for spray-off and blow-off also requires a thorough understanding of the salt dissolution process since the transition between the spray-off and blow-off is determined by the dissolution of salt.

9.2.1. The loss processes

Run-off

In the model presented here no contribution from run-off is assumed. Whether this assumption is correct for the presented cases of field observations can be discussed. Nevertheless, an improved model that is applicable for all kinds of situations should include the contribution of run-off. It is likely that the function describing run-off will depend on whether there is a steady supply of water to the road surface or if the supply of water to the road surface has just started or ended. The supply of water can take the form of either precipitation or melting of ice and snow.

An equation describing the run-off from the road surface is proposed by Sass (1992):

$$\begin{aligned} Q_{RO} &= K_{RO}(W - W_C), \text{ for } W > W_C \\ Q_{RO} &= 0, \text{ for } W < W_C \end{aligned} \quad (9.2)$$

Where:

- Q = Run-off per time unit
- K_{RO} = Constant
- W = Water quantity on road surface
- W_C = Critical quantity of water, threshold value for water quantity when run-off occurs

This model describes run-off as a function of the quantity of water on the road surface, W. The quantity of water is dependent on precipitation or the melting of ice and snow, but is also measured directly. Both the rate factor, K_{RO}, and the critical quantity of water, W_C, will probably be dependent on the road surface texture and cross-fall. The further development of a model for the salt quantity requires an investigation of how run-off is affected by these factors.

Spray-off and blow-off

For the traffic-dependent loss processes, known as spray-off and blow-off, several improvements can be made to achieve a more sophisticated and hopefully more precise model. An obvious improvement of the model presented here is to consider the effect of different vehicle types and vehicle speed. An important characteristic of the model presented by Blomqvist and Gustafsson (2004) is that traffic is divided into different vehicle groups and

the accumulated traffic is calculated in what Blomqvist and Gustafsson (2004) call private car equivalents. Vehicle types like buses and trucks are counted as several private car equivalents as it is obvious that they contribute more to the salt loss compared to private cars. To adapt the method of Blomqvist and Gustafsson (2004) of calculating the traffic in private car equivalents is possible and requires a further investigation of the differences in effect on salt loss of different vehicle types. Considerable research has been conducted on the “spray and splash” phenomenon of water on the road surface from heavy trucks, due to its effect on visibility and traffic safety (Clarke, 1983). It may be possible to utilize information from this research for a further development of the concept of salt loss due to spray-off (salt loss as brine). Due to the focus on traffic safety, the phenomenon of trucks “picking up” water from the road surface has been divided into splash and spray. Splash is defined as larger droplets (> 1.0 mm) of water that are created by the mechanical action of the vehicle tires and follows a ballistic path away from the tire, while spray is water droplets (< 0.5 mm) that are suspended in the air (Sanders et al., 2012). Although spray and splash are treated as separate processes when it comes to safety concerns regarding trucks, both processes will probably contribute to the loss of salt as brine, thus the common term spray-off is used to describe the salt loss as brine due to traffic. The splash and spray phenomena are created both by the vehicle tires and by drag and turbulence from the vehicle. The tire contact area and vehicle drag are variables to take into account when assessing the effect of different vehicle types and traffic speeds on the salt loss generated by traffic. By a simple calculation based on weight and tire pressure, the tire contact area of a heavy goods vehicle can be estimated to be 10 times the tire contact area of a private car. The aerodynamic drag of a vehicle is expressed by the following (Norem et al., 2002):

$$D = C_D \cdot \rho \cdot v^2 \cdot A \quad (9.3)$$

Where:

- C_D = Drag coefficient of the vehicle
- ρ = Density of the air
- v = Vehicle speed
- A = Exposed area of the vehicle (cross-section area)

The aerodynamic drag of a heavy goods vehicle can be estimated to be between 6 and 15 times the aerodynamic drag of a private car depending on the aerodynamic properties of the vehicles (Norem et al., 2002 and Göts and Mayr, 1998). Examining the aerodynamic drag of a vehicle can also be useful when investigating the speed dependency of the salt loss. As can be seen in Equation 9.3, the drag is a function of the vehicle speed squared (v^2) (Norem et al., 2002). Even though the contact area of the tires and the drag of vehicles are variables that can give information about the effect of different vehicles types and traffic speed it is not obvious how these variables are related to the loss mechanism of blow-off and spray-off: for example, whether there are linear relationships between these variables and the traffic-dependent loss mechanisms, and whether the drag is more important for blow-off than the mechanical action of the tires compared to spray-off.

9.2.2. Data

A further investigation of the processes is in itself useful for the physical understanding of salt on road surfaces after application, but to fully adapt a complex model to empirical data requires higher data quality. This can include data for other parameters, higher quality of the measurements and also higher time density of measurements. If more parameters are included in the model, it requires that these parameters be measured. An example of this could be traffic data. If the model takes different vehicle types into consideration, the data must contain

information on the different vehicle types. In this study the traffic data are divided into only two classes of vehicles, recorded only every hour and no data on actual traffic speed is available.

The salt quantity on the road surfaces is of course the most essential piece of data, but as shown in this study the quantity of water on the road surface is also important. A further development of a model requires better quality measurements of both salt and water quantity. As shown, there is significant data scatter in the data. Because these are parameters with substantial variation both in time and space, several repeating measurements in space are needed and higher time-density in the measurements.

10. CONCLUSIONS

When interpreting the results from the field observations presented in this study, it is crucial to take account of the limitations of the Sobo 20 used for measuring salt. The most important limitation is the fact that the Sobo 20 only measures dissolved salt. This is essential when analyzing salt application with dry or pre-wetted salt, but also measurements on recrystallized salt. In this study, field observation was performed when salt was spread as pre-wetted salt. The results from the field observations have shown that the measured quantity of salt after application cannot be described simply by a decrease in salt quantity. Shortly after application the Sobo 20 detects an increase in salt quantity, followed by a decrease in salt quantity. The quantity of water is very important for the salt quantity on road surfaces. Road surface wetness determines both the dissolution and the loss of salt. On wet road surfaces a rapid rise and fall in salt quantity has been recorded, while on moist road surfaces there are both a lower rate and magnitude of increase and decrease in salt quantity.

Based on the results from the field observations, three physical processes have been identified that control the changes in salt quantity after application:

1. Initial loss
2. Dissolution of salt
3. Loss of salt (traffic- and time-dependent)

The processes of salt loss (traffic- and time-dependent) can be divided into three separate loss mechanisms:

1. Blow-off
2. Spray-off
3. Run-off

Based on a discussion of the dissolution and loss process, a physically based model was established. The model was adapted to empirical data from the field study. The analyses show that the model produces a satisfactory fit with the data from field observation. It seems therefore reasonable to conclude that these processes and the model developed can explain the changes in salt quantity after application. Although the model seems to fit the data for salt measurements, it is realized that it makes some assumptions and simplifications that may be incorrect. To achieve a more precise model, further development is needed, for example the introduction of a function describing run-off and the incorporation of the effect of different vehicle types. In addition to a more complex model, data of higher quality are needed.

From the field observations and the developed model, some operational conclusions and recommendations can be made. It has been shown that there is a surprisingly rapid decrease in salt quantity after application and this is especially seen on wet road surfaces. This information is important in relation to the timing of preventive salt application, such as salting prior to frost, freezing water on road surfaces or before snowy weather. The short durability of salting actions means that salt application has to take place shortly before the expected weather situation to ensure that salt is present on the road surface. It is also important to remember that the loss of salt that is seen on wet road surface also represents a loss of water from the road surface, i.e. if there is no supply of water in the form of precipitation or melting, the road surface becomes less wet. On wet road surface it is therefore sensible to delay salt application until the road surface has become drier, and as close as possible to the expected weather situation. Reducing the quantity of water on the road surface, if possible, is a key factor in increasing the durability of salting action. Efficient plowing during and after snowfall is an important measure to reduce the quantity of water on the road surface after

snowfall. Less slush and snow after plowing will not only result in a reduction in application rates, but also increase the durability of salting actions. Efficient plowing includes proper equipment for slush removal (rubber sipes), proper mounting and adjustment of equipment and low speed during plowing. The use of equipment with brooms (sweepers) could be possible measures for additional removal of water, slush and snow. A pavement with low rutting will facilitate more efficient plowing and will therefore result in less water on the road surface. Low application rates when salting during snowfall for anti-compaction will give a drier road surface during and after snowfall.

The main results of this work are in the identification of the physical processes and in the principle of building a physically based model for the salt quantity on road surfaces. The attempt to understand the physical processes is essential to achieve a more thorough understanding of the phenomena. A thorough understanding of these physical processes is not only useful when establishing a model for salt quantity. Examples of other areas where this information could be useful are:

- Assessing and selecting measuring methods and procedures for salt on road surfaces as well as interpretation of measuring results
- Understanding how different spreading methods affect the salt quantity on road surfaces after application
- Assessing different measures for increasing the durability of salting actions, for example additives to salt.

REFERENCES

- ASFT. (2011) *Frensor - Freezing Point Detection* . ASFT .
http://www.asft.se/aviation/Weather_Frensor.shtml
- Atkins, P. and Paula, J. (2010). *Physical Chemistry* (Ninth Edition). Oxford University Press, Oxford.
- Blomqvist, G. and Gustafsson, M. (2004). Patterns of Residual Salt on Road Surface Case Study. *Sixth International Symposium on Snow Removal and Ice Control Technology*. Spokane, Washington. Transportation Research Board. Transportation Research Circular E-C063, pp 602-608.
- Blomqvist, G. and Gustafsson, M. (2012). Residual Salt and Road Surface Wetness: Comparison of Field Techniques. *International Conference on Winter Maintenance and Surface Transportation Weather*. Coralville, Iowa. Transportation Research Board. Transportation Research Circular E-C162, pp 443-449.
- Blomqvist, G., Gustafsson, M., Eram, M. and Unver, K. (2011). Prediction of Salt on Road Surface: Tool to Minimize Use of Salt. *Transportation Research Record: Journal of the Transportation Research Board* (2258), pp 131-138.
- Bodnar, R.J. (1993). Revised equation and table for determining the freezing point depression of H₂O-NaCl solutions. *Geochimica et Cosmochimica Acta*, 57 (3), pp 683-684.
- Burtwell, M. (2004). Deicing Trials on UK Roads - Performance of Prewetted Salt Spreading and Dry Salt Spreading. *Sixth International Symposium on Snow Removal and Ice Control Technology*. Spokane, Washington. Transportation Research Board. Transportation Research Circular E-C063, pp. 564-584.
- Chappelow, C.C., McElroy, A.D., Blackburn, R.R., Darwin, D. , Noyelles, F.G.d., and Locke C. E. (1992). *Handbook of Test Methods for Evaluating Chemical Deicers. SHRP-H-332*. Washington DC, Strategic Highway Research Program. National Research Council.
- Clarke, R.M.(1983). *Heavy Truck Splash and spray Suppression: Near and Long Term Solutions*. SAE Technical Paper Series, 831178.
- Colbeck, S.C. (1979). *The Compaction of Wet Snow on Highways*. Transportation Research Board Special Report, 185, pp 14-17.
- Colbeck, S.C. (1997) *A Review of Sintering in Seasonal Snow*. CRREL report 97-10.
- COST. (2008) *New Development for Winter Service on European Roads*. Final Report, Cost Action 353.
- Engen, H. (2006) . *Forsøk med å utvide bruken av fastsandmetoden for å bedre friksjonen på vinterveger*. Master Thesis. Norwegian University of Science and Technology, Trondheim, Norway.

- Ericsson, B. (1995). *Prosjekt Restsalt - En sammanfatning av kunskapsläget*. Vägverket publ. 1995:062
- Fonnesbech, J.K. (2001). Ice Control Technology with 20 Percent Brine on Highways. *Transportation Research Record: Journal of the Transportation Research Board* (1741), pp 54-159.
- Fullerton, G.D., Keener, C.R., and Cameron, I.L. (1994). Correction for Solute/Solvent Interaction Extends Accurate Freezing-Point Depression Theory to High-Concentration Range. *Journal of Biochemical and Biophysical Methods*, 29 (3-4), pp 217-235.
- Garrick, N.W., Nikolaidis, N.P., and Luo, J. (2002). *A portable method to determine chloride concentration on roadway pavements*. 2002. The New England Transportation Consortium.
- Göts, H. and Mayr, G. (1998). Commercial vehicles. In: Hucho, W (Editor), *Aerodynamics of Road Vehicles* (Fourth Edition). Society of Automotive Engineers, Warrendal, Pa., pp. 415- 488.
- Haavisto, V., Haavasoja, T., Turunen, M. and Nylander, P. (2000). *Performance of a Road Surface Conditions Sensor*. 10th SIRWEC Conference. Davos, Switzerland.
- Hammond, D.S., Chapmann, L., Baker, A., Thornes, J.E, and Sandford, A. (2006). Fluorescence of road salt additives: potential application for residual salt monitoring. *Measurements Science and Technology*, 18, pp. 239-243.
- Hanke, H. (2010). *Optimized Spreading of Salt and Brine in Winter Service*. PIARC, XIIIth International Winter Road Congress, Québec.
- Helbæk, M. (1999). *Fysikalsk kjemi*. Fagbokforlaget, Bergen, Norway.
- Holen, Å. (2010) *Salt SMART - Alternative kjemikalier og tilsetningstoffer til natriumklorid - en litteraturgjennomgang*. Staten vegvesen (Norwegian Public Roads Administration). Teknologirapport, 2593.
- Hunt, C.L., Mitchell, G.F., and Richardson, W. (2004) Field Persistence of Anti-Icing Sodium Chloride Residuals. *Transportation Research Circular, Sixth International Symposium on Snow Removal and Ice Control Technology*. Spokane, Washington. Transportation Research Board. Transportation Research Circular E-C063, pp 609-622.
- Jonsson, P. (2009). Road Status Sensors - A comparison of active and passive sensors. *16th ITS World Congress and Exhibition on Intelligent Transport Systems and Services*. Stockholm, Sweden.
- Jonsson, P., Blomqvist, G. and Gustafsson, M. (2008). Wet Dust Sampler - Technological Innovation for Sampling Particles and Salt on Road Surface. *Seventh International Symposium on Snow and Ice Control Technology*. Indianapolis Indiana. Transportation Research Board. Transportation Research E-Circular E-C126, pp 102-111.

The quantity of salt on road surfaces after application

- Jouin, D., Giloppé, D., and Pecquard, P. (2010). *Optical Recognition of Road De-icing Product*. PIARC XIIIth International Winter Road Congress, Québec.
- Kaufmann, D. W. (1960). *Sodium Chloride - The Production and Properties of Salt and Brine*. Reinhold Publishing Corporation, New York.
- Kim, J.S. and Yethiraj, A. (2008). The effect of salt on the melting of ice: A molecular dynamics simulation study. *The Journal of Chemical Physics* 129(12), pp 124504-124507.
- Klein-Paste, A. (2008a). Physical processes that affect runway conditions during winter time - A conceptual model. *Seventh International Symposium on Snow and Ice Control Technology*. Indianapolis Indiana. Transportation Research Board. Transportation Research E-Circular E-C126, pp 537-543.
- Klein-Paste, A. (2008b.) *Reduction in salt use by additives to salt - field trials during winter 2007/08*. Statens vegvesen (Norwegian Public Roads Administration). Teknologirapport nr. 2523.
- Klein-Paste A. and Wåhlin, J. (2011). Controlling the properties of thin ice layers on pavement surfaces - an alternative explanation for anti-icing. *Physics and Chemistry of Ice*, Vol 12, pp 13-20.
- Koefod, S. (2008). Eutectic Depressants - Relationship of Eutectic Freezing Point and Ice Melting Capacity in Liquid Deicers. *Seventh International Symposium on Snow and Ice Control Technology*. Indianapolis Indiana. Transportation Research Board. Transportation Research E-Circular E-C126, pp. 73-85.
- Lalagüe, A., Hoff, I., Eide, E. and Svanekil, A. (2009). Use of Ground Penetrating Radar for detection of salt concentration on Norwegian winter roads. *Eight International Conference on the Bearing Capacity of Roads, Railways and Airfields*. CRC Press/Balkema, Leiden, The Netherlands.
- Marchetti, M., Claverie, R., Livet, J., Durickovic, I., Bourson, P., Chassot J. M., Fontana M.D. and Kaufmann, T. (2010). Remote determination of residual de-icer with an optical spectroscopic tool. PIARC XIIIth International Winter Road Congress, Québec.
- Minsk, L.D. (1998). *Snow and Ice Control for Transportation Facilities*. McGraw-Hill, New York.
- Moore, J.W., Stanitski, C.L. and Jurs, P.C. (2011). *Chemistry - The Molecular Science*. Brooks/Cole, Cengage Learning.
- Mullin J.W. (2001). *Crystallization* (Fourth edition). Butterworth-Heinemann, Oxford.
- Norem, H. (2009). *A winter maintenance strategy for roads based on climatic factors*. VTI rapport 630A. Linköping, Sweden, Swedish National Road and Transport Institute (VTI).

- Norem, H., Satran, L.R. and Thordarson, S.(2002). Measures to reduce the generation of “snow smoke” behind heavy vehicles. *PIARC XIth International Winter Road Congress*.
- Norem, H. and Thordarson, S. (2001) *Winter Maintenance Practice in the Northern Periphery*. ROADEX Sub project B Phase 1.
- Nygaard, H. (2003) *Restsaltmåleren SOBO 20*. Vinterudvalget Denmark.
- Nygaard, H. (2005) *Restsaltmåleren SOBO 20*. Vinterudvalget. Denmark.
- Peryy, A.H. and Symons, L.J. (1991). *Highway Meteorology*. E & FN Spon.
- Raukola, T., Kuusela, R., Lappalainen, H. and Rasmussen, P. (1993). Anti-Icing Activities in Finland: Field Tests with Liquid and Prewetted Chemicals. *Transportation Research Record: Journal of the Transportation Research Board* (1387), pp 48-56.
- Russ, A., Mitchell, G.F. and Ricchardson, W. (2008). Durability of brine applications for winter maintenance on asphalt and PCC pavements. *87th Annual Meeting of the Transportation Research Board*. Washington D.C..
- Sanders, P.D., Dunford A., Viner H., Flintsch, G.W. and Larson, R.M. (2012). Splash and spray assessment tool development program. First interim report: revised synthesis report. Transport Research Laboratory, PPR602..
- Sass, B.H., 1992. A Numerical Model for Prediction of Road Temperature and Ice. *Journal of Applied Meteorology*, 31(12), pp 1499-1506.
- Transportation Research Board. (2007). *Guidelines for the Selction of Snow and Ice Control Materials to Mitigate Environmental Impacts*. NCHRP Report 577.. Washington D.C.
- Trost, S.E., Heng, F.J. and Cussler, E.L. (1988) Chemistry of Deicing Roads - Penetrating Ice. *Journal of Transportation Engineering- Asce*, 114(2), pp 221-231.
- Turunen, M. (1997). Measuring salt and freezing temperature on roads. *Meteorological Application*, 4: 11-15.
- Vaa,T. (1995) *Salting og trafiksikkerhet*. Statens vegvesen (Norwegian Public Roads Administration).
- Vaa,T. (2004). Implementation of New Sanding Method in Norway. *Sixth International Symposium on Snow Removal and Ice Control Technology*. Spokane, Washington. Transportation Research Board. Transportation Research Circular E-C063, pp. 273-286.
- Vaa,T. (2005) *Salt befuktet med varmt vann. Forsøk sesongen 2004/2005*. Statens vegvesen (Norwegian Public Roads Administration). Teknologirapport 2416.
- Vaa,T. and Sakshaug, K.(2007) *Salting av veger - en kunnskapsoversikt*. Statens vegvesen (Norwegian Public Roads Administration). Teknologirapport 2493.

The quantity of salt on road surfaces after application

- Vigneault, C. and Gameda, S. (1994). Effect of addition of water on snow compaction. *Energy*, 19(2), pp 187-194.
- Wallman, C.G. (2002). Tema Vintermodell. Olyckesrisker vid olika vinterväglag (In Swedish). VTI notat 60-2001. Linköping, Sweden, Swedish National Road and Transport Institute (VTI).
- Wang, J. and Flanagan, D.R. (2009). Fundamentals of Dissolution. In: Qui, Y., Chen, Y., and Zhang, G.G.Z. (Editors), *Developing Solid Oral Dosage Forms : Pharmaceutical Theory and Practice*. Academic Press, Amsterdam, pp. 309-318.
- Wang, H., Liu, L. and Chen, Z. (2010). Experimental investigation of hydronic snow melting process on the inclined pavement. *Cold Regions Science and Technology*, 63(1-2), pp 44-49.

Kai Rune Lysbakken

Paper I:

**Measuring salt on road surfaces
- A discussion of salt concentration versus salt amount**

**Presented at 14th SIRWEC Conference
Prague, 14th -16th of May 2008.**

**Measuring salt on road surfaces
- A discussion of salt concentration versus salt amount**

Kai Rune Lysbakken

PhD-student at the Norwegian University of Science and Technology,
Department of Civil and Transport Engineering,
Trondheim, Norway

ABSTRACT

The amount of salt is critical for the state and development of road surface conditions. Knowledge and information about the amount of salt is therefore crucial for decision makers in winter maintenance. In principle, salt can be measured by two different units of measure; (1) salt concentration (g/l), or salt amount (g/m²). It has become customary to express salt amount as freezing point i.e. as salt concentration. These two units of measure are different and do not express the same information. The robustness of a road can be seen as the capacity to meet the expectant weather and traffic conditions without getting drastic and unexpected changes in road surface conditions. The robustness of a salted road can be seen as the capacity against freezing. Information from salt measurements used in decision making has to give information of the robustness of the road. Robustness of a road can not be fully described by using salt concentration as a unit of measure. In some conditions the salt amount has to be known to assess the robustness and in some conditions both salt concentration and salt amount is needed.

Keywords: roads, winter maintenance, salting, measuring salt

1. INTRODUCTION

The application of salt or other chemicals often forms an essential element in the winter maintenance of roads. It is applied to; prevent freezing (anti-icing), melt ice or snow (de-icing) or prevent the build-up of compacted snow on road surfaces (anti-compaction and anti-adhesion). There are several factors that determine the effectiveness of a salt application. The most critical factors are considered to be timing, the mechanical removal of snow and slush prior to the application and spreading rate of the application. The amount of salt on the road surface is critical for the road surface conditions and whether ice formation or snow compaction occurs or not. Recognizing this, information or knowledge about the amount of salt on road surface after salt application is crucial for decision makers in winter maintenance.

The background for this paper was a study on the development of salt amount on roads after salt application. The objective of the study was to investigate how the salt amount developed after application, to understand the mechanisms that remove the salt from the road and to identify the important parameters behind these mechanisms. Part of this study is presented in Lysbakken and Norem [1]. To perform such a study it was necessary to do measurements of salt on road surfaces. This need for performing salt measurements lead to a basic question: *What is the appropriate unit of measure for salt on road surfaces?*

This paper is a discussion of what is the appropriate unit of measure for salt on road surfaces. The discussion is made in perspective of the decision making process and in the perspective of research and development activities. It is principles that are discussed and questions like the technical possibilities or challenges of measuring salt on road surfaces are not concerned.

2. TWO PRINCIPLE UNITS OF MEASURE

In principle, salt on road surfaces can be expressed by two different units of measures; (1) *in salt concentration*, or (2) *in salt amount*. Salt concentration is either given directly in gram per litre water or expressed in freezing temperature. Salt amount express the salt in grams per unit area. Salt concentration refers only to the dissolved salt, whereas the amount salt per unit area refers to the undissolved and dissolved salt.

Turunen [2] states that for historical reasons and for the sake of descriptiveness it has become customary to express salt amount on the road as freezing point, i.e. as salt concentration, based on the assumption that the freezing point is low when there is much salt on the road, and higher when there is a little. As Turunen [2] points out that approach is problematic.

There are several physical processes that influence on the road surface conditions [3]. Examples of such processes are precipitation, ice deposition, evaporation, spray-off and run-off. Some of these processes have an influence on the salt concentration or the amount of salt on the road. But these processes do not always influence both salt concentration and salt amount and not always in the same way. Consequently, there is not always a linear relationship between these two dimensions. Precipitation or deposition of dew are physical processes that add water on the road surface and thereby reduces salt concentration. However, they will not affect the amount of salt per unit area assuming that the amount of water is insufficient to cause run-off or spray-off. In the same way, evaporation will increase the salt concentration, but not affect the amount of salt per unit area. On the other hand when the road is wet, but the precipitation (supply of water) has ended, spray-off or run-off reduces the amount of salt per unit area while the salt concentration is still constant. These examples

shows that the two main principles of measures of salt; salt concentration and salt amount per unit area, are different and does not express the same information

The relationship between the salt concentration and the salt amount per unit area are obvious. The amount of water (brine) per unit area on the road surface decides the relationship between them. If the salt concentration is known and the amount of water per unit area known, then the salt amount per unit area are known.

3. MEASURING SALT IN PERSPECTIVE OF THE DECISION MAKING PROCESS

Decision making in winter maintenance implies making decisions and taking actions based on questions like: *“How is the road surface conditions at the time? How will the road surface conditions develop? Is maintenance actions required? What type of maintenance actions is needed? When to apply salt? How much salt to apply?”* A large diversity in weather and road surface conditions both spatial and in time, makes decision making in winter maintenance a challenging task. A key to successful use of salt in winter maintenance is to perform proactive salting actions. That means that the spreading of salt shall take place before the road surface becomes slippery or snow compaction occurs. This requires that the decision maker has information about the present weather situation, weather forecast and the prevailing road surface conditions. Recognizing that the amount of salt is critical for the road surface conditions, information about the amount of salt is should be an important part the information that decision makers require.

In Norway, road contractors and their decision makers are recommended to use salt measurements as important information in decision making. Several instruments are presented as feasible for this purpose, see figure 1. Some of them are measuring salt on road surfaces as salt concentration and some as salt amount. No discussion is made which of the two units of measure that is appropriate, and if the information given by these instruments are the same and can be interpreted in the same way.

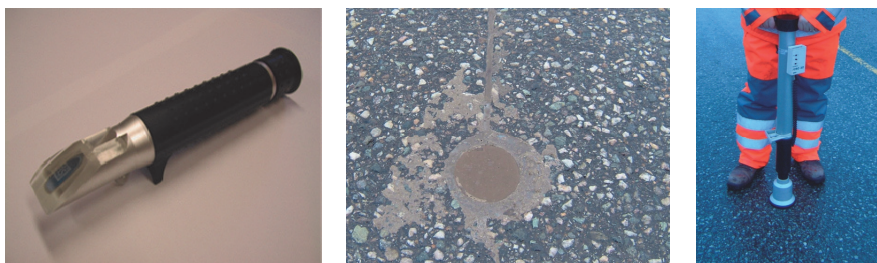

Figure 1. Refractometers, road sensors and Sobo 20 are examples of instruments presented for decision makers for measuring salt on road surfaces.

3.1. Using salt measurements for information in the decision making process

In general, from salt measurements or in any type monitoring of road surface parameters, there are two types of or information that can be derived:

1. the state of road surface conditions at the moment
2. the robustness of road surface conditions

The robustness of the road surface conditions can be seen as the road surface capacity to meet the expectant weather and traffic conditions [4]. That means that the road conditions should ideally be in a state so that the expectant weather and traffic conditions do not give drastic and unexpected changes in road surface conditions. The robustness of a salted road can be seen as

the road surface capacity against freezing. By taking into account the proactive nature of salting the robustness of the road surface conditions is the most important information from road surface monitoring. Hence, the readings from salt measurements have to give information about the robustness of the road surface. So, which of the two principle measures for salt on road surface, concentration or salt amount, express the robustness of the road surface? Can just one of them cover all type of road and weather conditions or is both needed?

Strictly there are three weather situations that can make a bare road slippery and thereby cause a need for salting actions:

1. A supply of water due to precipitation or dew on a dry, cold road
2. An increase of water amount due to precipitation on a wet road
3. A drop of road surface temperature on a wet road

On a dry road with surface temperature below 0° C dew will deposit as ice. Rain or super cooled rain will freeze to ice and snow can be compacted to form a snow layer. The robustness of the situation is depended on the salt amount salt that is present and how much water that will be supplied to the surface in form of precipitation or dew. On a dry road there is meaningless to talk about salt concentration and the robustness can only be assed by knowing the salt amount. If the road is wet, salt is present and precipitation is expected, the robustness of the situation can neither be assessed by only knowing the concentration or the salt amount per unit area. For example a high salt concentration but small amount of brine means that the salt amount is small. That means it only takes small amount of precipitation before the brine is so diluted that freezing can occur. Opposite, a high salt amount per unit and high amount of water also means that there can be only relatively small amount of precipitation before freezing can occur. One must know the salt amount and the amount of water to asses how much the amount of water can increase before freezing will occur. One must consequently know the relationship between the concentration and the salt amount to assess the robustness. If the expected weather is a drop in temperature and the road is wet the robustness of the situation can easily be assessed by knowing the salt concentration. A drop in temperature and a dry road with no hazard for deposit of water is of course not a relevant problem. The table below shows which unit of measure that is needed to assess the robustness of road surfaces under different weather and road conditions.

Expected weather conditions:	Information needed to assess the robustness:
supply water on a dry, cold road	salt amount
increase of water amount on a wet road	salt amount, salt concentration
dropping temperature on a wet road	salt concentration

Table 1. Information about amount of salt on road surfaces needed to assess the robustness of road surfaces under different weather and road conditions.

These theoretical examples may be conventionalized and does not fully correspond with all of the decision makers every day problems. But these examples clearly show that the approach of using salt concentration as the only unit of measure for salt on road surface uncritical is problematic. Salt concentration describes well the current state of the road surface conditions. If the road is wet and there is expected a drop in surface temperature, the robustness of the road is also well described by the salt concentration. On the other hand if precipitation or dew is expected on a dry, cold road the robustness can be assessed by the salt amount. If precipitation is expected on a wet, cold road surface both salt amount and salt concentration has to be know to assess the robustness.

The robustness of a road surface can not be described by the salt concentration alone in all conditions and therefore is insufficient unit of measure for salt on road surface.

3.2 Relating salt measurements to the other parts of the decision making system

In Norway the decision of winter maintenance actions are being taken on a low level in the organisation often meaning the operators of the maintenance trucks. This is partly because of historical reasons. Winter maintenance has been a low-tech area. But mainly this is due to the fact the large local and a timely variation in weather gives a diversity of road conditions so that local knowledge and presence is necessary. Decision making is often carried out by personal with low formal skills but high level practical knowledge. This fact requires that information given by systems meant for decision support has to be intuitive and coherent. How to interpret salt measurements expressed in salt concentration directly or by freezing point is not so evidently. This is partly because of the fact pointed out in the discussion made in chapter 3.2, and partly because all other information or tools does not use salt concentration as a unit of measure. Take the control unit on a salt spreader as an example. The spreading dosage is given in amount per unit area. The guidelines for salting give recommendations for spreading rates under different conditions also is in salt amount per unit area. It is not difficult to imagine that there is problematic to relate readings from e.g. a road sensor, giving a freezing point, to this other information the maintenance crew has.

It is the experience of the author that in Norway, salt measurements from e.g. road sensors are not highly used for decision making process. The problems addressed here seem to the author to be one of the main reasons for this fact.

4. MEASURING SALT IN PERSPECTIVE OF RESEARCH AND DEVELOPMENT

There is not only directly in the decision making process that salt measurements is desirable. In research and development activities this is highly relevant. Development activities that require salt measurements can be e.g. testing of salt spreaders, different spreading methods, spreading materials or additives to salt. Research activities can be documentation of the effect of maintenance actions and so on. These research and development activities can indirectly be related to decision making because the knowledge are often one of the basis for making salting guidelines, training of maintenance personnel and so on, i.e. a basis for better decision making. In this way the required information from salt measurements in research activities does not differ from the information needed in decision making. The discussion made regarding the unit of measure for salt on a road surface for decision making is relevant also for research problems.

The background for the authors interest in the discussion addressed in this paper was as stated earlier a research problem: *How does the salt amount develop after salt application? What are the mechanisms that remove salt from road surfaces and important parameters behind these mechanisms?* Field observation with salt measurements was essential. Without knowing about the discussion addressed here it seemed to be a proper method using data from road sensor installed with RWIS-stations in daily use as decision making support system. Road sensors expressing the salt on the road surface as freezing point. By giving these research problems a more thorough considering it was obvious that using salt concentration as a unit of measure would be incomplete. Using salt concentration would not reflect the movements of salt from and on a road surface at proper way. The amount of salt has to be measured as salt amount per unit area and be independent of the amount of water on the road surface. The

same conclusion has to be the same for many other research and development problems related to salting e.g. assessments of spreading methods or spreading equipment.

5. CONCLUSION

The amount of salt is critical for the state and development of the road surface conditions and therefore is knowledge about the amount of salt on the road surface important in the decision making process. The robustness of a road is an important concept considering road surface conditions and the robustness of a salted road can be seen as the capacity against freezing. If a drop in road surface temperature is expected on a wet road, salt concentration expresses well the robustness of the road. Precipitation or dew on a dry road means that the amount of salt has to be known to assess the robustness. On the other hand if the road is wet and precipitation is expected both salt concentration and salt amount has to be known to assess the robustness. The presented discussion has showed that using only salt concentration as a unit of measure for salt amount is not always sufficient.

REFERENCES

- [1] Lysbakken, K.R. and Norem, H. 2008. *The Amount of Salt on Road Surfaces after Salt Application*. Transportation Research Circular, Seventh International Symposium on Snow Removal and Ice Control Technology. In Press.
- [2] Turunen, M. 1997. *Measuring salt and freezing temperature on roads*. Meteorological Application, 4: 11-15.
- [3] Klein-Paste, A. 2008. *Physical processes that affect runway conditions during winter time - A conceptual model*. Transportation Research Circular, Seventh International Symposium on Snow Removal and Ice Control Technology. In Press.
- [4] Klein-Paste, A. 2007. *Runway Operability under Cold Weather Conditions*. PhD Theses. Norwegian University of Science and Technology.

ACKNOWLEDGEMENT

The author would like to thank the Norwegian Public Roads Administration for the financial support of this work. Thanks to my supervisor, Professor Harald Norem, and my colleague, Alex Klein-Paste, for help and inspiration with this paper. Also thanks to my colleague Bård Nonstad for valuable comments on this paper.

Paper II:

**The Amount of Salt on Road Surfaces after Salt Application
– a Discussion of Mechanisms and Parameters**

**Presented at Seventh International Symposium on Snow Removal and Ice
Control Technology in 2008. Transportation Research Circular E-C126.**

**The Amount of Salt on Road Surfaces after Salt Application
– a Discussion of Mechanisms and Parameters**

Kai Rune Lysbakken

PhD-student at the Norwegian University of Science and Technology,
Department of Civil and Transport Engineering,
Trondheim, Norway

Harald Norem

Professor at Norwegian University of Science and Technology,
Department of Civil and Transport Engineering,
Trondheim, Norway

ABSTRACT

Field observations have been made to study the development of salt amount on road surfaces after salt application. The objective of the study has been to understand the mechanisms that remove salt from road surfaces after spreading and identify important parameters behind the mechanisms. After salt application salt is transported from the road surface by the three mechanisms; denoted as blow-off, spray-off and run-off. The mechanisms are affected by several parameters grouped in weather parameters, traffic parameters and road characteristics. Four case studies are presented where the amount of salt was measured with Sobo 20. Weather, traffic and winter maintenance activities were recorded. The amount of water on road surface was measured by using absorbent textiles. The results show that the amount of water on the road surface controls the development of salt amount on road surface. Both the mechanisms of salt loss and how much salt becomes dissolved are governed by the amount of water on the road surface. On a wet road surface more salt will be dissolved compare to a moist road surface. This lead to a higher peak value in the amount of dissolved salt (which is detected with the used instrument). Further, on wet road surface there will be a more rapid loss of salt, due to a higher effect of spray-off.

1. INTRODUCTION

Important aims for winter maintenance of roads are to achieve a high level of accessibility, regularity and traffic safety during the wintertime. Securing a sufficient level of is essential to achieve these aims. Snow and ice removal and friction control are therefore the most important activities in winter maintenance of roads. Mechanical and chemical methods are used both for snow and ice removal and for friction control.

Independent of the purpose of a salting action, whether it is to prevent freezing (anti-icing), to melt ice or snow (de-icing), or to prevent the build-up of compacted snow on road surfaces (anti-compaction and anti-adhesion), there are several critical factors that determine the effectiveness of the application. The most critical factors are timing and spreading rate of the application. The amount of salt on the road surface is critical for the road surface conditions and whether or not ice formation or snow compaction occurs. How long the salt remains on the road surface after application is therefore vital for the road surface conditions. Knowledge of the development of the amount of salt after a salt application is relevant for:

- Decision-makers
- Establishing guidelines
- Research and development activities

The person making the decision when to salt and how much to spread benefits from having insight in how much and how long salt remains on the road surface. At higher organisational levels it can be useful knowledge in the work on optimizing the use of salt using guidelines for salt application. The knowledge can, for example, be used further to assess spreading methods under different surface conditions.

There have been several studies on the development of salt amount on road surfaces. Blomqvist and Gustafsson (1) studied the distribution of salt in the cross-section of the road and developed a model for development of the salt amount as a function off traffic. Hunt, Mitchell and Richardson (2) studied the development of salt amount after brine application. Glue (3) investigated also the development after brine application. These studies, however did not consider the amount of water that is present on the road surface.

This work describes a field study on how the amount of salt on road surfaces develops after a salting application. The objective is to understand the mechanisms that remove the salt from road surfaces and identify the important parameters behind these mechanisms. Issues concerning the actual spreading of salt are not addressed in this work. Questions like the efficiency of different spreading methods are not concerned.

2. MECHANISMS THAT CONTROL THE AMOUNT OF SALT ON ROAD SURFACES

There are several parameters that influence the amount of salt on road surfaces. To understand further how the amount of salt develops after salting actions, it is useful to identify the mechanisms that remove salt from the road surface. Considering the road surface as a system, movements of salt out of the system can be observed. Assuming that salt is evenly distributed in a longitudinal direction, the flow of salt in and out of the system can be seen in 2D, a cross-section profile of the road.

Three removal mechanisms can be identified; denoted as 1) blow-off, 2) spray-off and 3) run-off. These mechanisms are illustrated in FIGURE 1.

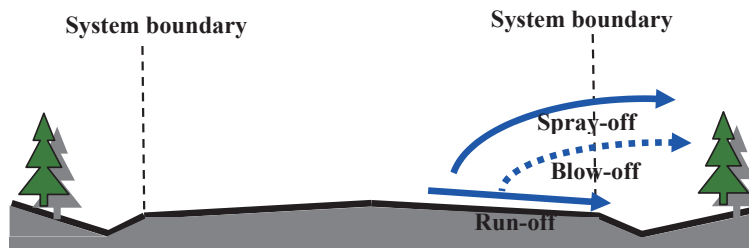

FIGURE 1 Cross profile of a road with the salt loss mechanisms illustrated.

Blow-off

The mechanism of blow-off is the removal of solid salt grains from the road. Blow-off is caused by traffic and thus depends on the number of vehicles, type of vehicles and traffic speed. In addition wind will probably increase blow-off. Blow-off will also be affected by the road surface conditions such as how wet the road is, if snow, ice or slush is present. Pavement texture will probably also influence. A coarse texture may “hold” onto the grains to a greater extent than a fine texture.

Spray-off

Spray-off is dissolved salt that is sprayed off the road surface. Spray-off is directly controlled caused by traffic and thus depends on number of vehicles, type and speed. Similarly for spray-off, other parameters may also affect the mechanism. A wet road surface will give more spray-off than a dry or moist one. Wind will increase the spray-off effect. A coarse texture on pavement was found to give less spray-off. (4)

Run-off

Run-off is gravity driven drainage of liquid from the road. Run-off will probably onset when there is a critical amount of water that has been collected on the road surface. The system of pores in the pavement will have to be “saturated” before run-off occurs. When the amount of water on the road surface has reached this critical value, run-off will take place. This can be seen as a threshold-value. Both the threshold-value and the flux will depend on the road surface texture, cross-fall and rutting.

Redistribution in the cross-section profile

Salt is redistributed within the system. Redistribution is not a removal mechanism but it can change the salt distribution within the boundaries. A normal part of redistribution is that salt is transported from the wheel tracks to the area between wheel tracks and the shoulder and thereby results in less salt in wheel tracks (1).

TABLE 1: Mechanisms that Removes Salt from a Road Surface and the Parameters Affecting the Mechanisms

Mechanism	Weather	Traffic	Road characteristics
Blow-off	Wind Amount of water on road surface - precipitation	Amount Speed Vehicle type	Texture
Spray-off	Wind Amount of water on road surface - precipitation	Amount Speed Vehicle type	Texture Rutting
Run-off	Amount of water on road surface - precipitation		Texture Rutting Cross-fall

The table above summarizes the loss mechanisms and the important parameters that control each loss mechanism. As stated earlier, for blow-off and spray-off, traffic is the “driving force” for the mechanisms. Blow-off and spray-off are in that respect a function of traffic. The “driving force” of run-off is gravity rather than time. Since run-off becomes only significant after a critical amount of water, it seems natural in most cases to plot salt amount as a function of traffic.

3. FIELD STUDIES

Field observations were carried out on ploughing/salting route on the E6 south of Trondheim, Norway. The strategy for the maintenance standard requires that the road surface shall be free of snow and ice, except during snowfall. After snowfall the road shall be free of snow and ice within 4 hours after the snowfall ended. The selected strategy for winter maintenance requires that chemical methods are used for friction control and chemical methods along with ploughing are used after snow removal. On this route salt is spread mostly as prewettered salt (prewettered with 30 % water) or as dry salt.

The road is a typical two-lane road with an AADT (Average Annual Daily Traffic) of approximately 5000. A certain point on the road was chosen for data collection. FIGURE 2 shows the road and the location for field observation. Regular observations were conducted during the winter seasons of 05/06 and 06/07. Each observation period is considered as an individual case.

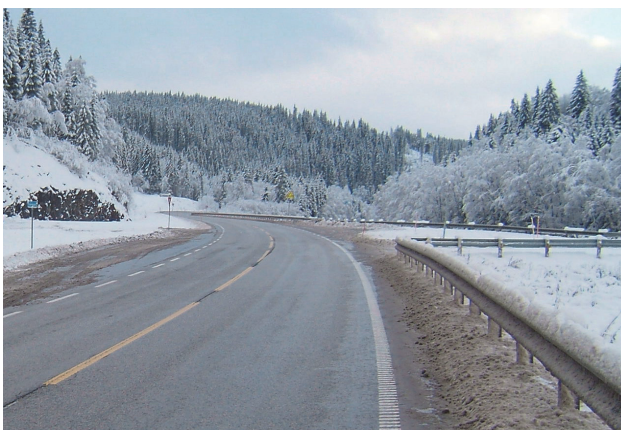

FIGURE 2 The site and the road chosen for field studies.

The basic method for the field studies was to document the road surface conditions and collect data in connection with ordinary maintenance measures and salting action on this section of the road.

3.1. Data collection

The collection of data included both automatic and manual data collection. The parameters relevant for this analysis are:

- Automatic data:
 - Data from maintenance trucks
 - Traffic data
- Manual data:
 - Weather parameters
 - Water on road surface
 - Salt amount

The maintenance trucks had a system based on GPS (Global Positioning System) and GSM (Global System for Mobile communications) for logging maintenance measures. This system logs when and what type of maintenance measures that are being conducted. This includes the spreading rate and snow removal. The traffic data includes number of cars and number of heavy vehicles every hour.

Air and road temperature, dew point, precipitation as well as salt amount and amount of water on road surface were measured. The measuring techniques are presented in chapter 3.2 and 3.3. Road surface conditions were documented by taking photographs and qualitative descriptions.

3.2. Measuring salt amount with Sobo 20

Salt amount were measured by using the instrument Sobo 20, see FIGURE 3.

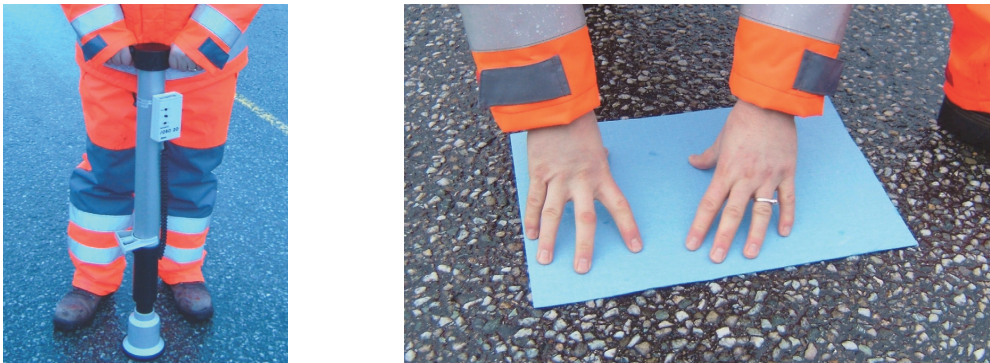

FIGURE 3 Measuring salt amount with Sobo 20 and water amount with Wetex textile.

The instrument has a mouthpiece that is placed on the road surface. This mouthpiece has a rubber gasket which encloses a known area. When pressing the instrument against the surface, a known amount of measuring fluid is sprayed on to the road surface. The measuring fluid is a mixture of acetone and water. The instrument measures the electric conductivity in the measuring fluid. By having a defined area of measurement, a known amount of measuring fluid and the electric conductivity, the instrument calculates the amount of salt on the road surface in g/m^2 . A more thorough description of Sobo 20 is found in (5).

During the field observations salt amount were measured in the right-wheel track and between wheel tracks. Each time three repetitions in the longitudinal direction were made and the average from these three readings was calculated.

3.3. Measuring road surface water with Wetex

The amount of liquid was measured by using a absorbent textile called Wetex, see FIGURE 3. By placing a textile piece of known dimensions (0.265×0.410 m) on the road surface it will absorb the present liquid. The amount of liquid per unit area was determined by weighing the textile before and after the absorption. It was recognized that this was not a very precise and flawless method because it is never possible to absorb all the water. However, it is simple, rapid and provides relative data on how wet a road surface is. Measurements were taken in right-wheel tracks and between wheel tracks.

For data presentation and analyses, the following classification of wetness for road surfaces has been used:

TABLE 2: Definition of Moist and Wet Road Surface

Road surface wetness	Amount of water [gr/m²]	Equivalent water film thickness [mm]
Dry	0	0
Moist	0-100	0-0.1
Wet	>100	>0.1

4. RESULTS FROM FIELD STUDY

4.1. Case 1: 2007.01.24

Observation period: 24 January 2007, from 04:00 to 18:00.

The weather was lightly clouded and with air temperature at 04:00 on -12.4°C and road surface temperature of -13.6°C . During the observation period they increased to -7.7°C and -7.2°C , respectively. In the wheel tracks the surface had scattered ice crystals, but not to the extent where the road surface became slippery. The roads were salted at 06:30 with 30 g/m^2 of prewetted salt. After salting and rising temperatures the road surface in wheel tracks became moist. Between wheel tracks there was some loose snow that became slush during observation time.



FIGURE 4 The observation point at 07:56 and 09:20.

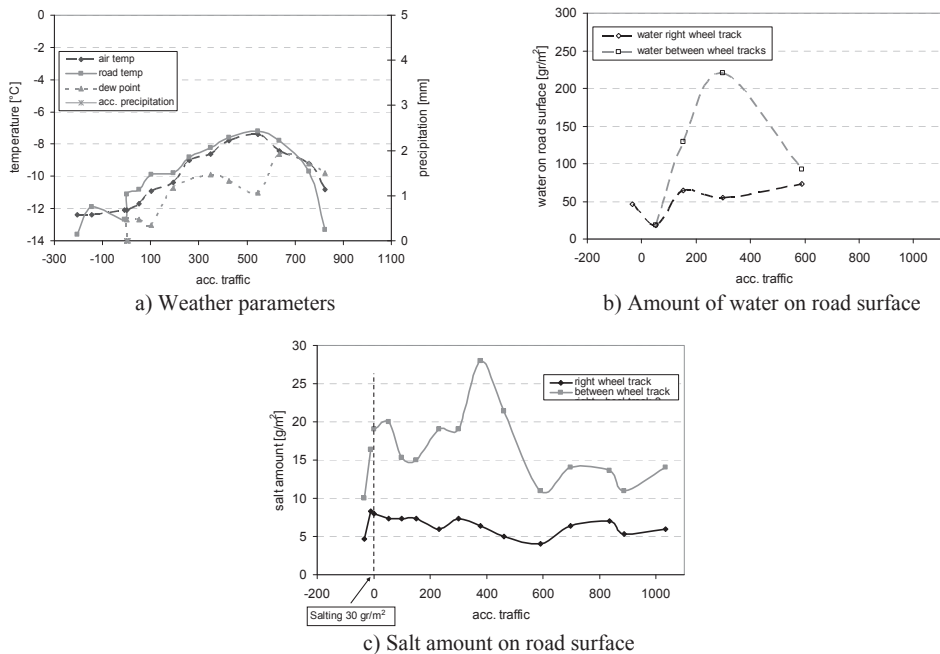

FIGURE 5 The data recorded in case 1.

4.2. Case 2a: 2007.01.31 – south bound lane

Observation period: 31 January 2007, from 04:00 to 14:00.

There was a light cloud cover with some precipitation in the form of sleet and snow around the time of the salting action. Maximum and minimum air temperatures were +2.1° C and +0.2° C, respectively. Road temperature was a maximum of +0.8° C and a minimum of -0.1° C. The road surface was wet, and there was some slush between the wheel tracks. Salt application in the south bound lane took place at 06:38 with 30 g/m² of prewetted salt.



FIGURE 6 The observation place at 07:50 and at 12:43

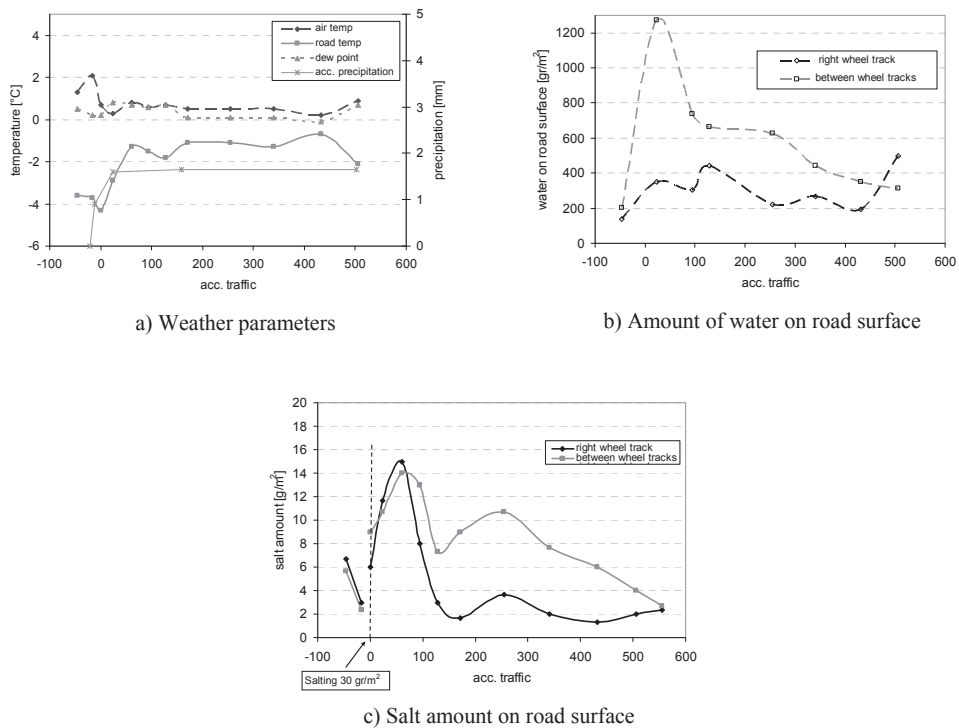

FIGURE 7 Data collected in case 2a.

4.3. Case 2b: 2007.01.31 – north bound lane

This shows the same time and condition as case 2b, except that the data is collected in the north bound lane. Here, the salting took place at 07:13. The application rate was 30 g/m² of prewetted salt.

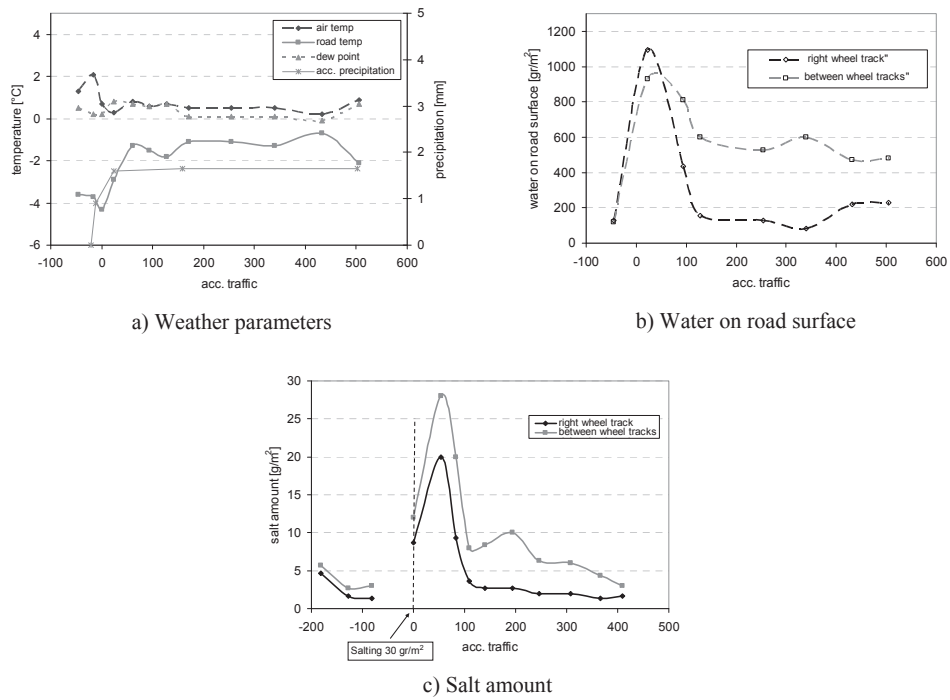

FIGURE 8 Data collected at case 2b.

4.4. Case 3: 2007.02.27

Observation period: 27 February 2007, from 09:00 to 17:30.

The weather was cloudy with rising temperatures. The air temperature was a minimum of -2.1° C and of a maximum +2.3 °C. The minimum and maximum road temperatures were -0.6° C and -3.3° C, respectively. The road surface could be characterised as moist. There was some light snow on the road surface at the beginning of the observation. Salting took place at 10:14 with an application rate of 30 g/m² with prewetted salt.



FIGURE 9 The observation point at 09:21 and 16:15.

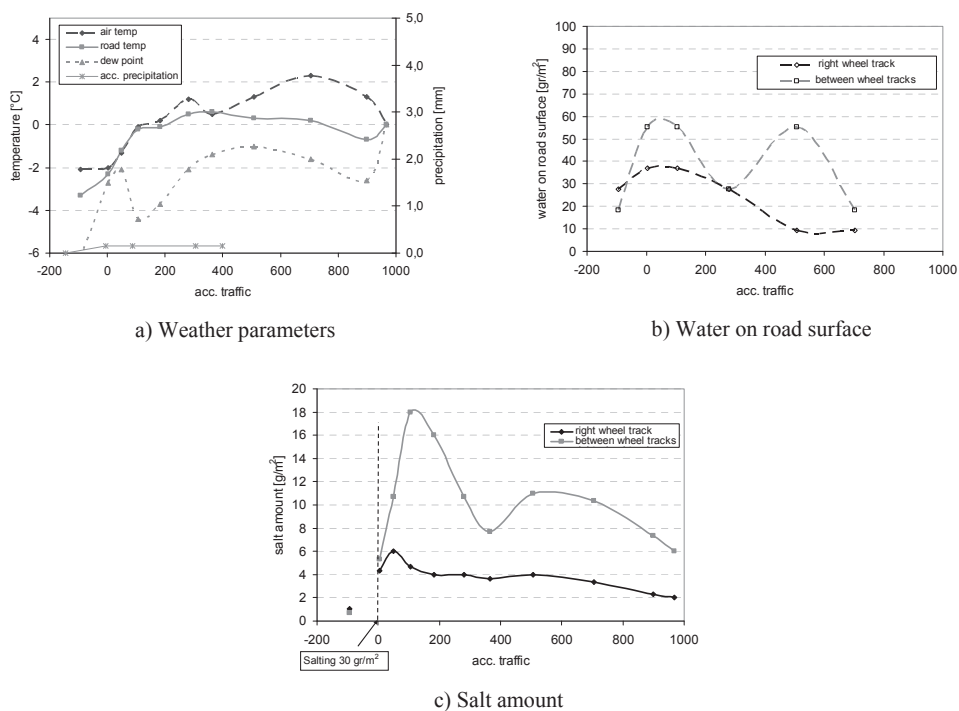

FIGURE 10 Data collected for case 3.

5. DISCUSSION

The dissolving of salt

The first important fact one should have in mind when analysing the results from measurements of salt amount is the limitation of the instrument Sobo. Sobo measures the electric conductivity in the measuring fluid. This means that Sobo measures the salt dissolved in the measuring fluid. Tests have shown that the measuring fluid dissolves solid salt that lies inside the measuring area only to a limited extent. If there is a lot of undissolved salt on the road surface, Sobo will only measure a certain ratio of the salt that is present. The fact that Sobo measures little of the undissolved salt on the road surface explains the shape of the curves that plot salt amount versus time or traffic. If Sobo has measured the total amount of salt on the road surface, one would expect a curve like FIGURE 11a. The highest amount of salt should be measured immediately after salt application. Instead measurements with Sobo show a development as in FIGURE 11b. These are idealized curves. The general trend is: Immediately after application the measured salt amount is low, then the amount of salt increases before there is a decline in the salt amount when the mechanisms of salt loss become dominant. The first part of the curve before the peak occurs can be explained by the fact that there is a time- and traffic-dependent process where salt is being dissolved. The salt is present, but is not detected with a measuring instrument like Sobo. As more of the salt dissolves, more salt is measured by Sobo.

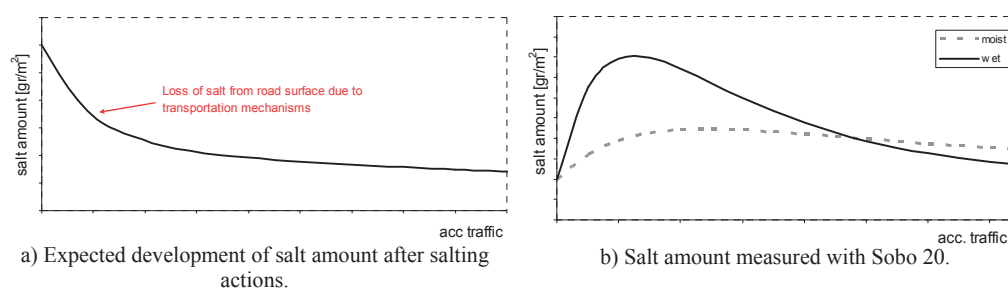

FIGURE 11 Idealized curves for the development of salt amount after salting actions.

One can also see that the shape of the curve is different when observing salting on wet road surfaces versus moist road surfaces. On a wet road surface there is a clear gradual rise in measured salt amounts and relatively high peaks followed by a rapid loss. In cases where only the road surface is moist, there is neither a rapid rise in measured salt amount nor a high peak value. The cause for these differences is that on a road surface with small amount of moisture there is insufficient water present to dissolve the salt to the same extent as on a wet road surface. The solubility curve for salt shows that at 0 °C 1 gram of salt needs approximately 2.8 grams of water to be fully dissolved (a salt brine is saturated at 26.3 weight percent of salt at 0 °C). Theoretically that means that if dry salt is spread with a rate of 30 g/m² there has to be 84 g/m² of water present to fully dissolve the salt. This aspect, combined with the notion that dissolving is time depended, explains the differences between a moist and a wet road surface. On moist road surfaces, when most of the salt is finally dissolved and thereby is detected by the Sobo instrument, much of the salt is blown and sprayed off the road. These differences between moist and wet road surfaces can clearly be seen when comparing results from field observations. The fact that the amount of water is important for the process of dissolving salt, and thereby salt that is detected by Sobo, can also clearly be seen in cases 1 and 3, FIGURE 5 and FIGURE 10. In these cases there is a substantial difference in the

amount of water inside the wheel tracks compared to between wheel tracks. For this reason there is a more rapid rise and larger amount in measured salt between wheel tracks compared to inside wheel tracks. The amount of salt is also higher between wheel tracks due to the redistribution within road surface.

The loss of salt

The transport mechanisms of salt depend on the amount of water present on road surfaces as indicated in Section 2. FIGURE 12 shows the salt amount in wheel tracks plotted as a function of traffic for all four cases. The data points are grouped into wet or moist road surface according to the definition presented in TABLE 2.

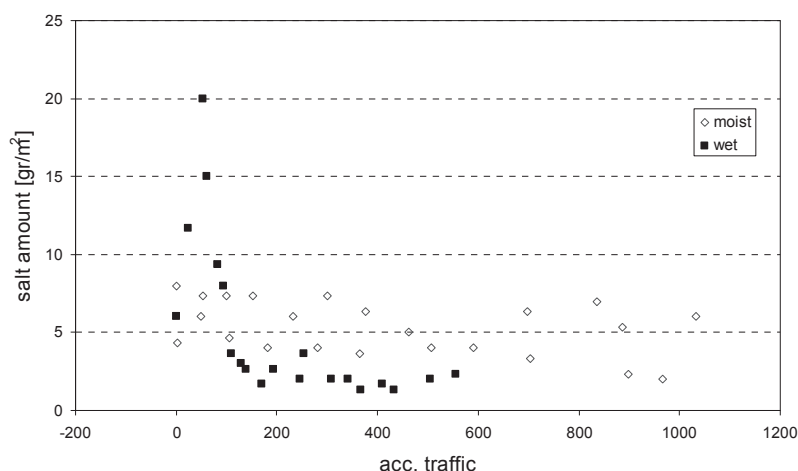

FIGURE 12 Salt amount inside wheel tracks. Data from all four case studies grouped according to wet and dry road surface.

Immediately after spreading one should be careful to compare the data for moist and wet road due to the fact that Sobo does not measure dry salt, and to limited degree, dissolves dry salt. Exactly where the data is comparable (all salt dissolved) is not known. Considering FIGURE 12 the data shows the clear tendency that there is a more rapid loss of salt on wet road surfaces. The magnitude of the loss is also greater on wet compared to moist road surfaces. After about 150 cars the amount of salt is clearly higher on moist road surfaces compared to wet road surfaces. The mechanism of spray-off on wet road surfaces seems to be more important compared to the blow-off effect on moist road surfaces. The salt seems to be present longer on the road surfaces on moist compared to wet road surfaces. This is because on a moist road surface when finally the salt is dissolved there is no or very little spray-off.

The results from the field observations clearly show that the amount of water on road surface is controlling the development of salt on road surface after salting actions. How wet the road surface is will decide what type of loss mechanisms that governs the development and the magnitude of the loss mechanisms. A dry or little moist road surface will give a large blow-off effect, but no or little spray-off and no run-off. More amount of water will give more spray-off and at a wet road surface one will also have run-off.

6. CONCLUSION

The removal of salt from road surfaces is described by the three mechanisms blow-off, spray-off and run-off. The controlling parameters are discussed and can be grouped in weather, traffic and road characteristics.

Field observations including salt amount measurements have shown interesting results with respect to the discussion of the transport mechanisms. The results have shown that the amount of water controls the development of salt on the road surface. Road surface wetness determines which removal mechanism that is dominant and the magnitude of the loss. The dissolving of salt is highly depended on amount of water on road surface. It is shown that the development of salt amount on road surfaces are substantial different on moist road surfaces compared to wet road surfaces. On wet road surfaces there is a more rapid rise and fall of salt amount compared to moist road surfaces. There is a higher maximum value on the amount of salt on wet road surfaces that can be detected with the used instrument. However, on moist road surfaces the salt remains longer on the road surface because of less or no spray-off. This means that there are higher amount of salt on moist road surface compared to wet after the same amount of traffic has passed.

The instrument Sobo can be used examine the questions addressed in this work, but the results should be interpret in considerations of the known the limitations of Sobo. A further exploration of the mechanisms of blow-off and spray-off requires the development of an instrument than can measure the total amount of salt, not only the dissolved salt.

ACKNOWLEDGMENTS

The authors would like to thank the Norwegian Public Road Administration, by Tore Hoven, for the financial support of this work. Also thanks to our colleague, Alex Klein-Paste, for his valuable comments on this paper.

REFERENCE LIST

1. Blomqvist,G. and Gustafsson,M. Patterns of Residual Salt on Road Surface Case Study. Sixth International Symposium on Snow Removal and Ice Control Technology. *In Transportation Research Circular, E-C063*. TRB, National Research Council, Washington, D.C., 2004, pp. 602-608.
2. Hunt,C.L., Mitchell,G.F., and Ricchardson,W. Field Persistence of Anti-Icing Sodium Chloride Residuals. Sixth International Symposium on Snow Removal and Ice Control Technology. *In Transportation Research Circular, E-C063*. TRB, National Research Council, Washington, D.C., 2004, pp. 609-622.
3. Glue,T. Restsaltmengdernes afhengighed af trafikken. Report. In Danish. 2000.
4. Elvik,R. and Greibe,P. *Safety Aspects Related to Low Noise Road Surfaces*. EUROPEAN COMMISSION DG TREN - GROWTH, SILVIA - Sustainable Road Surfaces for Traffic Noise Control, 2007.
5. Nygaard,H. *Rapport Restsaltmåleren SOBO 20*. Report. In Danish. Vinterudvalget Denmark. 2003

Lysbakken and Norem

Paper III:

**Processes that Control Development of Salt Quantity on Road Surfaces after
Salt Application**

**Presented at the Transportation Research Board (TRB) 89th Annual Meeting
in 2010. Journal of Transportation Research Board No. 2258 in 2011.**

Processes That Control the Development of Salt Quantity on Road Surfaces after Salt Application

Kai Rune Lysbakken
PhD-student at the Norwegian University of Science and Technology,
Department of Civil and Transport Engineering.
Trondheim, Norway

Harald Norem
PhD, Chief Engineer
Norwegian Public Roads Administration
Trondheim, Norway

ABSTRACT

This paper is part of a larger project to study how the quantity of salt on road surfaces develops after salt application. The goal of the work presented in this paper was to identify the physical processes that control the development of salt quantities on road surfaces. Field observations were made to study the quantity of salt after application. The results suggest that the development of salt quantity after salt application is controlled by three processes: initial loss, dissolution of salt, and loss of salt. A theoretical approach was taken to investigate the process of salt dissolution. The paper presents a principal, physically based model of the measured salt quantity on road surfaces as a function of traffic. It is proposed that the dissolution of salt be expressed by an exponential equation and that the rate of dissolution depends mainly on the quantity of water on the road. The loss of salt caused by blow-off and spray-off is considered to follow an exponential curve. The resultant equation that incorporated the dissolution and the loss was compared with field observations of moist and wet road surfaces.

Is not included due to copyright

Paper IV:

Field Observations on the Quantity of Salt on Road Surfaces after Salt Application.

Presented at the Transportation Research Board 89th Annual Meeting in 2010.

Field Observations on the Quantity of Salt on Road Surfaces after Salt Application

Kai Rune Lysbakken

PhD student at the Norwegian University of Science and Technology,
Department of Civil and Transport Engineering.
Trondheim, Norway

ABSTRACT

The work presented in this paper is part of a project to study the quantity of salt on road surfaces after salt application. Field observations were conducted and the quantity of salt was measured, as well as data on weather, road surface conditions and traffic. The quantity of salt is presented as a function of traffic. The results show significant differences in the quantity of salt after application between the various observations and some of these differences can clearly be explained by the quantity of water on the road surface. The quantity of water on the road surface determines the quantity of salt after application. Wet road surfaces both dissolve and lose salt more rapidly than moist road surfaces. The data also shows that there is a surprisingly rapid loss of salt, especially on wet road surfaces. After 200 to 400 passing vehicles, the quantity of salt equals that before application. A physical based model is used to model the salt quantity as function of traffic. The model produced an acceptable fit to the data, but it is concluded that the data scatter is too large for the model to be precise enough for decision-making purposes. Despite this, the data allows some conclusions to be drawn and some operational advice to be given.

1. INTRODUCTION

Winter maintenance is essential to uphold a high level of accessibility, regularity and safety on roads during winter time. Salting is an important method of snow and ice control. There are several factors that determine the success of a salt application, of which the most important are considered to be:

- application rate and timing with respect to weather conditions and traffic
- removal of slush and snow prior to salting
- spreading method appropriate to road surface conditions

Therefore, decision-making in the salting of winter roads must take into account several elements in determining the type and timing of measures. When assessing the need for salt application, important factors are not only the impending weather and road situation, but also the quantity of residual salt on the road surface at the time deciding the time and rate of re-application.

The work presented in this paper is part of a project to study the how the quantity of salt on road surfaces develops after salt application. The main goal of the project is to obtain knowledge of how the quantity of salt develops after application. Further, to identify the physical processes that control this development and to identify and understand the important parameters affecting these physical processes. These questions have been addressed by carrying out field observations and studying the development of the quantity of salt in different situations. A discussion of the physical processes is presented in Lysbakken (1) and the mechanism behind the loss of salt from road surfaces is presented in Lysbakken and Norem (2). These studies made use of data from field observations by studying them as single cases and attempting to generalize the observed trends.

In this paper, data from all the field observations are presented, and observations are analysed in relation to the processes presented previously. The paper examines whether the data from these field observations could be used to develop a model for the quantity of salt after application, for decision-making purposes.

2. FIELD OBSERVATION

2.1. The observation site

Several field observations were conducted throughout the winter of 2005/2006 and 2006/2007. The field observations were carried out on a salting and ploughing route on a highway south of Trondheim, Norway. The specifications for the winter maintenance standard of this route require that the road shall be free of snow and ice, except during snowfall. Four hours after a snowfall has ceased the road should be free of snow and ice. These specifications for winter maintenance require that chemical methods be used for friction control, along with ploughing for the removal of snow.

The road is a two-lane road with an Average Annual Daily Traffic (AADT) of approximately 5000. Observations were made during weather incidents that required ordinary maintenance measures. The picture below shows the observation site, FIGURE 1.



FIGURE 1 The site for field observations.

2.2. Data collection

During the field observations, several types of data were collected. The data relevant for this presentation are:

- Automatically collected data:
 - Data from maintenance truck (application rate, time and so on)
 - Traffic data
- Manually collected data
 - Weather parameters including road surface temperature
 - Quantity of water on road surface
 - Quantity of salt on road surface

The winter maintenance truck on this route has a system based on GPS (Global Positioning System) and GSM (Global System for Mobile Communications) for the recording of winter maintenance activities. This system logs when and the type of activity being conducted, including both ploughing and salt-spreading. In the 2005/2006 season this system was not working quite correctly, so the activities were in addition recorded manually by the vehicle operator. Traffic data include the number of vehicles and the number of heavy vehicles per hour. The weather parameters include air and road temperatures, dew point and precipitation.

2.3. Measuring the quantity of water on road surfaces

The quantity of water was measured using a highly absorbent textile called Wettex. When placing a piece of known dimensions (0.265×0.410 m) on the road surface, it will absorb the surface liquid. The quantity of water can be determined by weighing the textile before and after absorption. It is recognized that this is only a rough method of estimating the quantity of water on the road surface, but is chosen because it is simple and demands no further types of instrumentation. The method is described further in Lysbakken and Norem (2) and in Klein-Paste (3).

2.4. Measuring the quantity of salt on road surfaces

The quantity of salt on the road surface was measured with the Sobo 20, produced by Boschung. It is a well known instrument which has been used in several similar studies. The instrument has a mouthpiece that is placed onto the road surface. On the mouthpiece is a rubber gasket which encloses a measuring area of known dimensions, see FIGURE 2. When the instrument is pressed against the road surface, a known quantity of measuring fluid, which is a mixture of acetone and water, is sprayed onto to the road surface. The instrument then measures the electrical conductivity in the measuring fluid. Having a defined area, a known quantity of measuring fluid and the electrical conductivity, the instrument then calculates the quantity of salt on the road surface in g/m^2 .



FIGURE 2 Measuring quantity of salt on road surfaces with the Sobo 20.

An important feature of Sobo 20 is that the electric conductivity depends on the quantity of dissolved salt, and in the experience of the author the Sobo 20 is not capable of measuring all the undissolved salt that may be present on the road surface. If there is both dissolved and undissolved salt present, Sobo will hence measure only a certain quantity of the salt on the road surface.

There are several advantages to the Sobo 20. Importantly, it is a low-weight and portable instrument, making it possible to take salt measurements everywhere in the cross profile of a road and everywhere along a section of road. The instrument also provides rapid measuring results. A more thorough technical description of the Sobo 20 can be found in Nygaard (4).

3. RESULTS

3.1. The data set

Field observations were conducted during periods of ordinary maintenance operations. It was a goal to perform measurements both before and after salt applications.

During the winter season of 2005/2006 and 2006/2007, a total of 20 field observations were conducted. Only seven of these observations resulted in complete data sets. A complete data set is defined as one salt application, and includes the following type of information:

- Data on winter maintenance activities including data on the salt application

Field Observations on the Quantity of Salt on Road Surfaces after Salt Application

- Quantity of salt on road surface (average from three Sobo measurements)
- Quantity of water on road surfaces
- Traffic data
- Weather parameters

The reasons that some of the observations did not yield a complete data set are:

- The weather conditions required no salt application during the observation period
- A failure in the system logging the maintenance data, or lack of a manual log by the maintenance crew, resulted in lack of information about the salt application
- Heavy snowfall made salt measurements with the Sobo 20 impossible

The southbound lane (lane 1) and northbound lane (lane 2) are in most cases salted separately, and consequently there are two salt applications, one for each lane. At the observation point approximately one hour elapsed between the salt application of lane 1 and lane 2. Two salting applications meant that each observation period typically gave two data sets. Information that resulted in a complete data set is shown in the table below.

TABLE 1 Observations Resulting in Complete Data Sets.

Date	Weather	Duration [h]	No. of data points	Salting in both lanes	No. of salt applications	Salting action
07.2.2006	Clear up	4,5	20	Yes	1	30 g/m ² prewetted
08.2.2006	Light snow	11,5	54	Yes	2	30 g/m ² prewetted
21.2.2006	Clear up	8,5	20	Yes	1	30 g/m ² prewetted
07.3.2006	Light snow, before clear up	11	40	Yes	1	30 g/m ² prewetted
24.1.2007	Light clouds, light snow	14	28	Yes	1	30 g/m ² prewetted
31.1.2007	Light clouds	10	24	Yes	1	30 g/m ² prewetted
27.2.2007	Cloudy	8,5	10	No	1	30 g/m ² prewetted
Total			196			

A data point is defined as the quantity of salt in wheel tracks paired with the time or traffic since salting. There are five observations of salting actions in both lanes, resulting in a total of ten data sets, and one observation of two salting applications resulting in a total of four data sets. During one observation there was salting action in only one lane, yielding only one data set. Overall this gives 15 data sets. As the table shows, the salting action is the same for all the observations in terms of both application rate and spreading method. That simplifies further analyses since no normalization of the quantity of salt is needed to compare the various data sets.

3.2. Lane 1 versus lane 2

FIGURE 3 shows all 196 data points. The quantity of salt in wheel tracks is plotted as a function of traffic from the time of salt application.

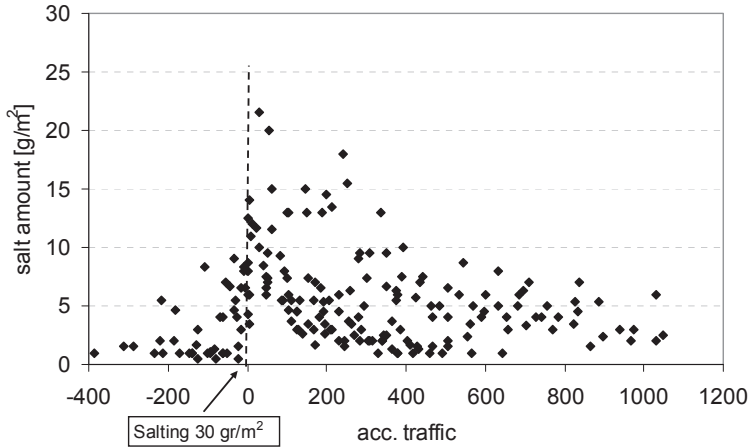

FIGURE 3 Quantity of salt as a function of traffic since salt application. Data from all observations.

FIGURE 3 illustrates a significant data scatter. Despite the same application rate, the development of salt quantity salt accumulation after application varies greatly for the different data sets (cases). It can also be seen that in some cases there are relatively high quantities of residual salt before application and there also appears to be a trend towards an increasing quantity before application. There is also a trend towards a maximum quantity of salt after approximately 50 to 300 cars have passed.

FIGURE 4 represents only the recordings from lane 1, which is the lane that is salted first.

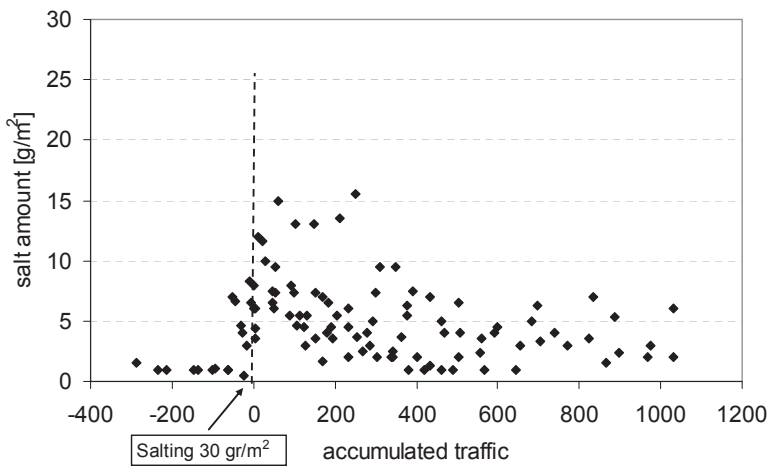

FIGURE 4 Quantity of salt in wheel tracks in lane 1 (salted first).

There is also a significant scatter in the data collected in lane 1, showing that there is a very different development in the quantity of salt after application for the various cases. From FIGURE 4 it can also be seen that there are fewer data points with high quantities of salt before application and that the apparent trend towards an increasing quantity of salt before application is not so evident as when plotting data for both lane 1 and lane 2.

FIGURE 5 and FIGURE 6 show the data plotted as single series for each data set (case).

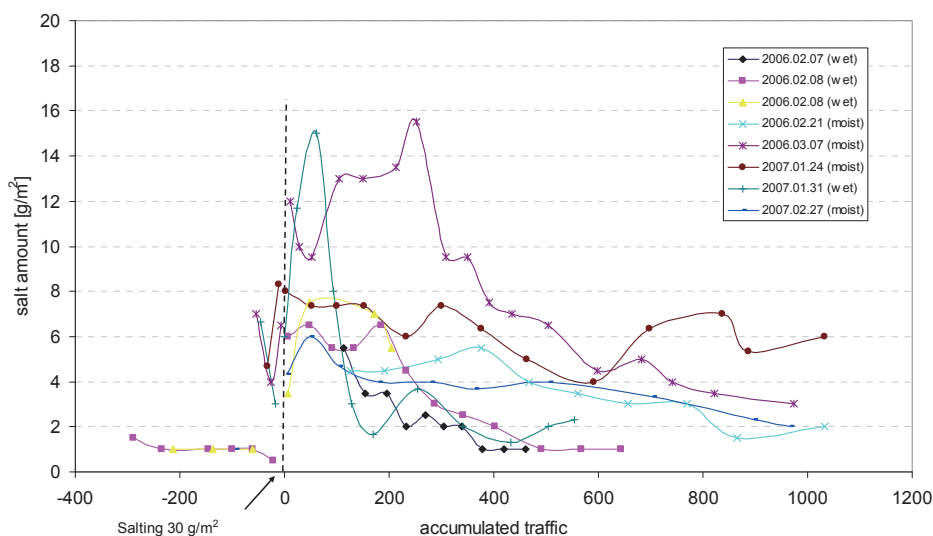

FIGURE 5 Quantity of salt in wheel tracks in lane 1 presented as a single series for each case.

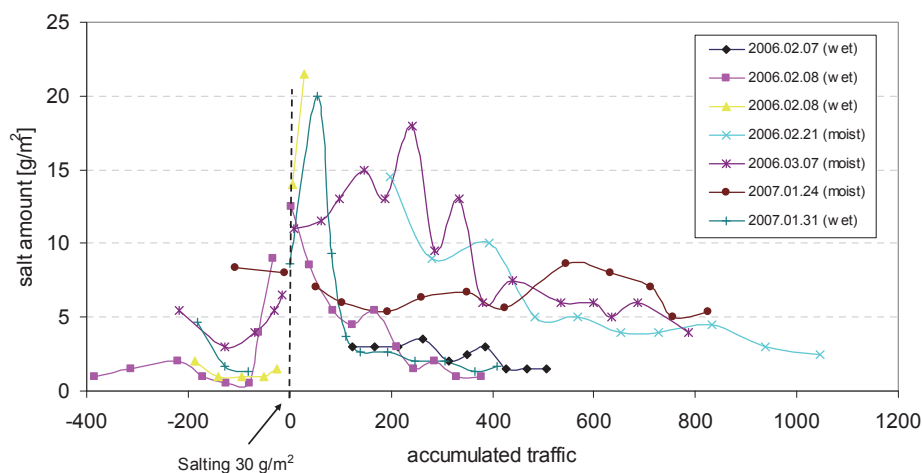

FIGURE 6 Quantity of salt in wheel tracks in lane 2 presented as a single series for each case.

The data presented as single series for each case also show clearly that the development in the quantity of salt varies greatly for the various cases. FIGURE 5 and FIGURE 6 also show that there are actually some cases with an increasing quantity of salt prior to application. In lane 1 there are two such cases, and both have a high level of salt before application. There are three cases in lane 2, which exhibit both high and low levels of salt before application. The possible reasons for such an increase before salt application are discussed later.

3.3. Moist versus wet road surface

For further analysis the data is divided into cases with moist and wet road surface. A moist road surface is defined having less than 100 g/m^2 of water and a wet road surface have more than 100 g/m^2 of water. 100 g/m^2 of water on a road surface is equivalent to a water film thickness of 0.1 mm . (2)

FIGURE 7 shows the average quantity of water on the road surface during the observation period for each case. The red line represents the limit between moist and wet road surface at 100 g/m^2 .

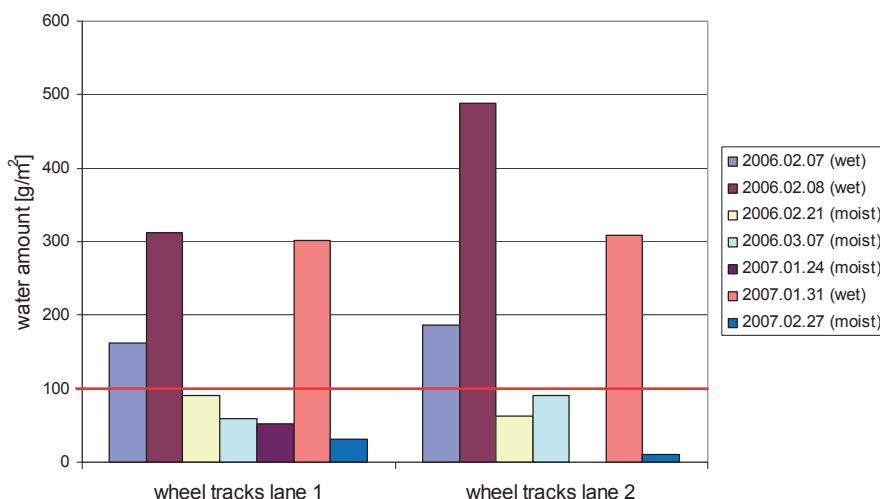

FIGURE 7 The average quantity of water on the road surface for each case

There are significant differences in the average quantity of water between the various cases, but there may also be a significant variation in the quantity of water within the observation period. This is illustrated in FIGURE 8 which shows examples of both wet and moist cases. One case is clearly wet but with a significant variation in the quantity of water. Two of the cases have an average quantity of water, defining them as moist, but the road surface was wet at the start of the observation period and the quantity of water was then gradually reduced over time. Finally, one of the examples is clearly moist during the whole observation period.

Field Observations on the Quantity of Salt on Road Surfaces after Salt Application

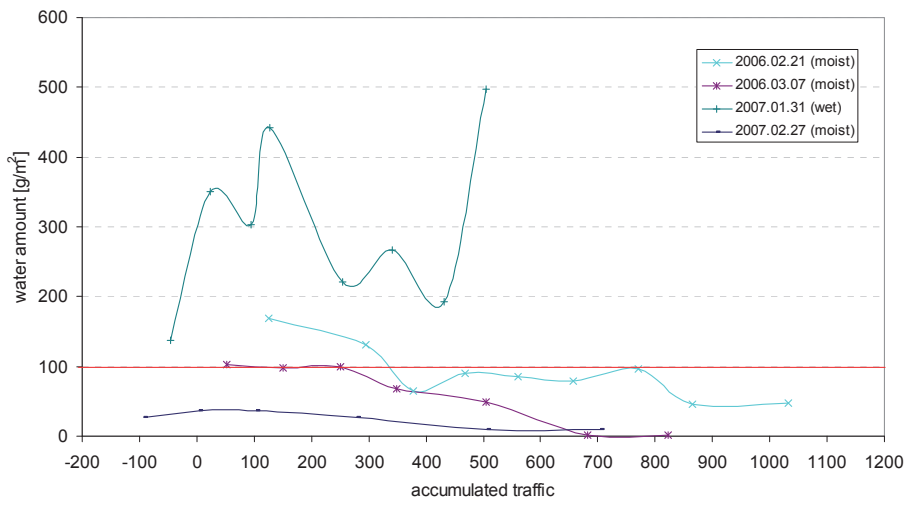

FIGURE 8 Examples of the development of water quantity on road surface during the observation period

FIGURE 9 shows cases from lane 1 divided into cases with wet and for moist road surfaces.

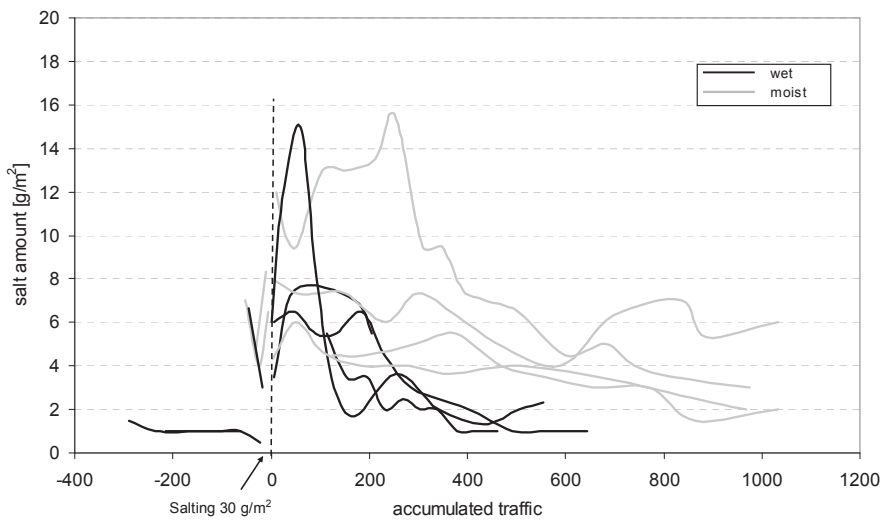

FIGURE 9 Salt quantity in wheel tracks in lane 1 divided into cases with wet or moist road surfaces

4. DISCUSSION

4.1. Increasing salt quantity before application

FIGURE 3 shows an apparent trend towards an increase in the quantity of salt prior to salting. Plotting the data as a single series shows that in several instances there was in fact an increasing quantity of salt before application. In lane 1 there were two instances of this, in both cases with a high quantity of residual salt. In lane 2 there were three such instances, and there are cases with both high and low quantities of residual salt. This increase in the quantity of salt before application has three possible causes:

- Increased quantity of dissolved salt due to an increase in the quantity of moisture on the road surface
- Redistribution of salt within the cross profile of the road due to changes in track selection of vehicles
- Redistribution of salt from lane 1 to lane 2

The first possible reason for an increase in the quantity of salt measured before application is salt crystallization resulting from the drying up of the road surface. As mentioned, the Sobo 20 instrument does not fully dissolve, and thereby detect, all undissolved salt. If moisture is added to the road surface, e.g. by precipitation, this may lead to an increase in the quantity of salt measured without an application having taken place. This phenomenon is described by Klein-Paste (3). From the weather parameters for the particular cases showing an increasing quantity of salt, it can be concluded that the increase in dissolved salt is not caused by an increased quantity of water. An increase in the quantity of salt can also occur due to redistribution within the cross profile of the road. This will occur if some vehicles select another wheel track. Traffic normally causes more salt to accumulate between and outside wheel tracks than inside wheel tracks, and when different tracks are selected by drivers, the salt from between wheel tracks can be redistributed. During the observation period, the observer and a vehicle were located beside the road. It was noticed that several vehicles chose to drive slightly to the left due to the presence of the observation personnel and vehicle. Finally, it is likely that the quantity of salt in the wheel track of lane 2 is influenced by the salting action in lane 1, which is salted before lane 2. Either salt will transfer directly to lane 2 during spreading in lane 1, or blowing of dry salt and spraying of dissolved salt caused by traffic will distribute salt from lane 1 to lane 2.

Since there are instances in both lane 1 and lane 2 of an increasing quantity of salt before application, it is likely that this is caused by redistribution within lanes due to changes in track selection, and by redistribution between lanes 1 and 2 due to different times of application.

4.2. Data scatter

Plotting the salt data both as points and as single series has revealed a significant data scatter. Firstly the various cases show very different developments in the quantity of salt after application, in terms of maximum quantity of salt after application, how rapidly the quantity of salt decreases, etc. Secondly, there is also a substantial data scatter within particular cases. There are cases where the quantity of salt varies greatly during the observation period, although there is a distinct trend.

The variation within each case shows clearly that the quantity of salt has a spatial variation in longitudinal direction in addition to a time-dependent (or rather traffic-dependent) variation. The

Sobo measurements cannot be made at exactly the same spot every time because the measuring fluid from previous Sobo readings would influence the readings. The variation in the quantity of salt between the cases reflects this longitudinal direction spatial variation, and the possibility that there was insufficient numbers of repeated Sobo measurements to level out this variation.

The data scatter caused by the variation in development of the quantity of salt between each case may have several reasons. The scatter within each case will naturally influence the greater picture. Variable quantities of salt before application will affect the development, at least the peak value of the salt quantity. There may be uncertainty in the application rate from one case to another. As is well known, several factors such as grain size distribution, moisture content of the salt, etc. can affect the calibration of the application rate on the salt spreaders. To minimize this uncertainty, the same vehicle and salt spreader were used in all cases. Although there are uncertainties/errors that can explain some of the differences in development in the quantity of salt between the various cases, the differences also reflects the existence of several factors that influence this development. The development in the quantity of salt after application cannot be explained by traffic alone. It therefore appears difficult or impossible to develop a single model for the quantity of salt as a function of traffic, based on data from these salt measurements.

4.3. The development of the quantity of salt on road surfaces

In spite of a significant data scatter, there are some interesting observations to be made by examining the results of the field observations.

The first fact to notice is that in the cases observed, the salting action has a surprisingly short durability in terms of the salt remaining on the road. This is due to the rapid loss of salt from the road surfaces. There is also an essential difference between cases that can be characterized as wet and those that can be characterized as moist. On wet road surfaces the loss of salt is more rapid than on moist surfaces. After 200 to 400 passing vehicles on a wet road surface, the quantity of salt will equal that before application. Hence it is possible to state that the durability on a wet road surface is 200 to 400 vehicles. On a moist road surface there is a longer durability, but this is also surprisingly short. 800 to 1000 vehicles or more can pass before the quantity of salt is down to the same level as before salting.

A comparison of data sets from all observations confirms the differences in development of the quantity of salt between moist and wet road surfaces reported by Lysbakken and Norem (2). By dividing the data into cases with wet or moist road surfaces, some of the data scatter can be explained, see FIGURE 9. Wet road surfaces both dissolve and lose salt more rapidly than moist road surfaces. There is also a higher peak value in the quantity of salt on wet than on moist road surfaces. These trends are present in all cases presented in this paper, although some cases show a slightly different development. These cases are defined as moist, but have high peak value and rapid loss during the first period of the observation, see FIGURE 5 and FIGURE 6. By examining these cases more closely, one can see that on average they have an quantity of water on the road that defines them as moist, but in the first period of the observation the quantity of water is above 100 g/m^2 , see FIGURE 8.

4.4. A model for the quantity of salt on road surfaces after application

Lysbakken and Norem (1) have presented a physical based model for the measured quantity of salt on road surfaces after application. The basis of the model is that the measured quantity of salt can be described by two processes; the dissolution of salt on the road surface and the loss of salt from the road surface.

$$S_M = S_D - S_L = C^* (1 - e^{-K_D T}) \cdot W - (S_A + S_R) [1 - e^{\ln(1-k)T}] \quad \text{Equation 1}$$

Where:

- S_M: Measured salt with Sobo [g/m²]
- S_D: Theoretical quantity of dissolved salt on road surface with no loss [g/m²]
- S_L: Accumulated quantity of salt lost from road surface [g/m²]
- C*: The equilibrium saturation at the given temperature
- K_D: The dissolution mass transfer coefficient (dissolution rate)
- W: The quantity of water on the road surface [g/m²]
- S_A: Available salt for dissolving [g/m²]
- S_R: Residual salt at the application time [g/m²]
- K: The loss rate
- T: The number of passing vehicles

FIGURE 10 shows the data from lane 1 and the model applied on these data. The data and model is divided into cases with wet and moist road surface.

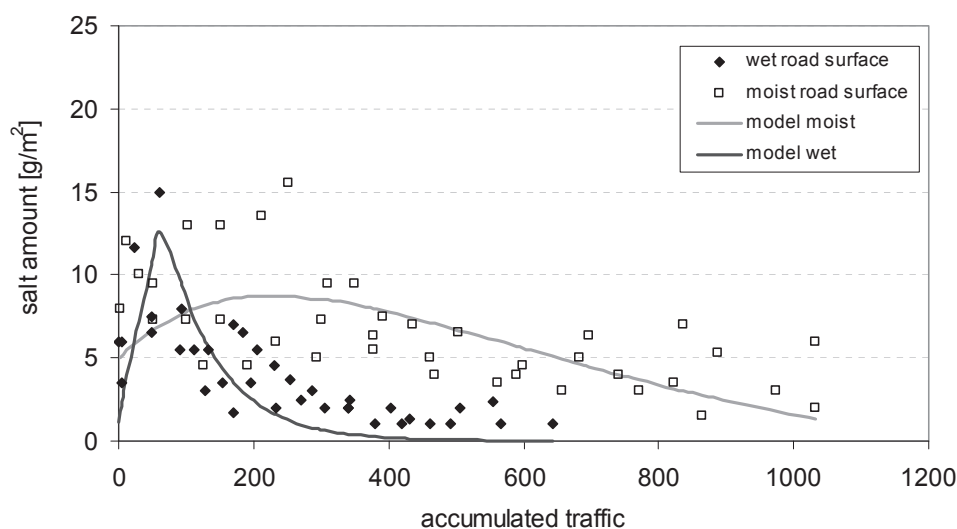

FIGURE 9 The data from cases from lane 1 and the model for measured quantity of salt

The figure shows that the model produce a satisfactory fit to the data. This confirms that the model can be used to explain the development in the measured salt quantity on road surfaces and that the identified processes control this development. Further it verifies that the quantity of water is an essential parameter controlling the quantity of salt after application. Although the model produces an acceptable fit to the data, the scatter in data is so substantial, that at present to adapt this model for decision-making purposes seems difficult.

5. CONCLUSION

The presentation of data from the field observation has revealed a significant data scatter on two levels. The data showed very variable development in the quantity of salt after application between different cases and there is also scatter within each case. By dividing the cases into moist and wet road surface some of the scatter can be explained. There are showed significant differences in the development in the salt quantity between moist and wet road surfaces. The physical based model presented in Lysbakken and Norem (1) is applied on the data. The model produced an acceptable fit to the date, but it is concluded that the data scatter is too substantial for the model to be precise enough for decision-making purposes.

Despite this, the data allows some conclusions to be drawn and some operational advice to be given. The rapid decrease in the quantity of salt on the road surface is the clearest observation to be made from these data. A salt application has surprisingly short durability, especially on wet road surfaces. This is important information in relation to preventive salting actions, such as salting before frost, freezing water or snow. The salt application must be carried out a short time before the weather situation occurs to ensure that salt is present on the road surface. An important aspect to remember is that loss of dissolved salt from the road surface also means loss of water from the road surface. Performing the salt application close to the expected weather situation may also cause the road to dry up, increasing the durability of the salt application. Reducing the quantity of water on the road surface is a key factor in increasing the durability of a salt application. Efficient ploughing after snowfall is an important measure to reduce the quantity of water. Less slush and snow after ploughing will not only require less salt to melt it, but also increase the durability. Efficient ploughing includes equipment to remove slush, proper mounting and adjusting of equipment, and low speed during ploughing. A pavement with low rutting will give a better ploughing result and also give less loss of dissolved salt from the road surface.

ACKNOWLEDGEMENT

The author would like to thank the Norwegian Public Roads Administration for the financial support of this work. I would like to thank my supervisor, Inge Hoff, for his valuable comments on this paper. My thankfulness goes to Harald Norem for his essential contribution to this paper.

REFERENCES

1. Lysbakken K.R. The Processes that Control the Development of Salt after Salt Application. *Submitted to the Transportation Research Board 90th Annual Meeting*, 2011.
2. Lysbakken K.R, Norem H. The Amount of Salt on Road Surfaces after Salt Application. *In Transportation Research Circular E-C126*. Washington D.C.: Transportation Research Board; 2008. p. 85-101.
3. Klein-Paste A. *Reduction in salt use by additives to salt - field trials during winter 2007/08*. Norwegian Public Roads Administration. Report No.: Teknologirapport nr. 2523. 2008.
4. Nygaard H. *Rapport Restsaltmåleren SOBO 20*. Vinterudvalget Denmark; 2003.

Paper V:

Accuracy of SOBO-20 in the measurement of salt on winter pavements

**Presented at the Transportation Research Board 92th Annual Meeting in
2013 and accepted for publication in the Journal of Transportation
Research Board.**

Accuracy of SOBO-20 in the measurement of salt on winter pavements

Kai Rune Lysbakken (corresponding author)
PhD-student at the Norwegian University of Science and Technology
Department of Civil and Transport Engineering
Trondheim, Norway

Anne Lalagüe
PhD student at the Norwegian University of Science and Technology
Department of Civil and Transport Engineering
Trondheim, Norway

ABSTRACT

The use of chemicals is essential in snow and ice control operations. Sodium chloride (salt) is normally used, as it is efficient, widely available and rather inexpensive. However it is harmful for the environment if encountered in too great quantities, and there is nowadays great attention placed upon the importance of reducing the usage of salt, while still maintaining road serviceability and safety. Optimizing the use of salt requires accurately knowing how much salt is already on a pavement surface. Unfortunately, there is currently no well-documented method available to determine this quantity. SOBO-20 is one of the most common instruments used by the winter maintenance community to calculate salt amounts, although the reliability of the instrument has not yet been shown. This present work aims to fill this gap by carrying out measurements on brine (dissolved salt), dry salt particles and re-crystallized salt. The presented results support the conclusion that SOBO-20 is an accurate and reliable instrument for measuring brine on asphalt pavements. However, it largely underestimates the amount of dry or re-crystallized salt, and more attention should be paid when using SOBO-20 on dry pavements. Compliance with the manufacturer's recommendations regarding the proportion of acetone in the measuring fluid is also essential for accurate salt readings. These results on the instrument performance should lead to a better understanding of salt distribution and action time.

Is not included due to copyright