

Tor Sverdrup Lilleeng & Eivind Høiseth

Development of a light, strong and mobile solution to accommodate elevated backrest in extreme conditions on a Franco Garda stretcher

Master's thesis in Industrial Design
Supervisor: Jon Herman Rismoen
Co- Supervisor: Anna Olsen
June 2023



Norwegian University of
Science and Technology

Tor Sverdrup Lilleeng & Eivind Høiseth

Development of a light, strong and mobile solution to accommodate elevated backrest in extreme conditions on a Franco Garda stretcher

Master's thesis in Industrial Design
Supervisor: Jon Herman Rismoen
Co- Supervisor: Anna Olsen
June 2023

Norwegian University of Science and technology
Faculty of Architecture and Design
Department of Design



Norwegian University of
Science and Technology

Eivind Høiseth & Tor Sverdrup Lilleeng

Development of a light, strong and mobile solution to accommodate elevated backrest in extreme conditions on a Franco Garda stretcher

Master's thesis in Mechanical Engineering
Supervisor: Anna Olsen
Co- Supervisor: Jon Herman Rismoen
June 2023



Norwegian University of
Science and Technology

Eivind Høiseth & Tor Sverdrup Lilleeng

Development of a light, strong and mobile solution to accommodate elevated backrest in extreme conditions on a Franco Garda stretcher

Master's thesis in Mechanical Engineering
Supervisor: Anna Olsen
Co- Supervisor: Jon Herman Rismoen
June 2023

Norwegian University of Science and technology
Faculty of Engineering
Department of Mechanical and Industrial Engineering



Norwegian University of
Science and Technology

PREFACE

Both Eivind and Tor have a respectable amount of experience working with medical equipment. Tor's bachelor thesis evolved around developing a boundary box/housing for a number of given components in a medical suction unit for a start-up. He later developed concepts for different pieces of equipment for the same company. On his semester on exchange in Australia he also did a conceptual project with the goal to reduce response times for ambulances in Brisbane in the year 2050.

Eivind has several years of experience being a lifeguard and has competed in lifesaving. He is a certified lifeguard from ILSE (International LifeSaving Federation of Europe) and is an instructor in advanced first aid from NLS (Norges Livrednings-Selskap). He has also worked as a ski patrol in Vassfjellet ski resort.

When choosing a direction for their master thesis they both wanted to work with something meaningful. They wanted to develop something that would be used after the project was done. Initially they researched the opportunity of doing a "Master med mening". This is a program that Engineers Without Borders has. Unfortunately, none of the projects they had this semester was a good match for them.

Through Tor's earlier work with medical projects, he has been using a friend that works as a paramedic to gain insight. This friend has several times recommended Tor to contact the Norwegian Air Ambulance when he was going to write his master thesis.

Tor and Eivind contacted the Norwegian Air Ambulance (NAA) in February 2022 and were planning to work on one relevant project regarding a medical stretcher for prehospital CT-scanning. However, during the summer, another person from the NAA contacted the Design Faculty at NTNU. He presented a problem that was a lot more urgent than the previous project. This is the elevated backrest problem. Just as the paramedics takes care of the most critical patient first, Tor and Eivind shifted to this project to solve the project most in need of urgent attention first.

Master thesis for student Tor Sverdrup Lilleeng

Development of a solution for elevated backrest on a rescue stretcher

When dealing with harsh conditions in challenging terrain, as often occurs in parts of Norway, the Norwegian Air Ambulance Foundation (NAAF) exchanges their regular stretcher to a more mobile and lightweight rescue stretcher called the Franco Garda. Doing so creates a problem as this stretcher lacks the ability to raise a patient to elevated backrest, which in some cases is crucial to keep the patient alive. This project will indulge in a New Product Development (NPD) process to address this problem.

The thesis will be conducted in collaboration with master student Eivind Høiseith at the Department of Mechanical and Industrial Engineering, and with the NAAF.

The thesis will include:

- Insights gained by interviews, observations and testing
- Comparisons to relevant existing equipment and solutions
- Development of a requirement specification
- Ideation, prototyping and concept development
- User testing in collaboration with NAAF
- Presentation of final concept

The project is carried out according to "Retningslinjer for masteroppgaver i Industriell design".

Hovedveileder: Jon Herman Rismoen
Biveileder: Anna Olsen
Bedriftskontakt: Martin Samdal

Utleveringsdato: 9. januar 2023

Innleveringsfrist: 29. mai 2023

NTNU, Trondheim, 9. januar 2023

Jon Herman Rismoen
Veileder

Sara Brinch
Instituttleder

ABSTRACT

After establishing contact with the Norwegian Air Ambulance (NAA), a project was presented as a potential master thesis. The project involved developing a new fixture for one of their medical rescue stretchers. More specifically the Franco Garda stretcher. [FG-stretcher]. A lightweight and tough french-built stretcher meant for rescue operations in challenging terrain. The stretcher can be dragged on any surface and can be hoisted from a helicopter. One thing it can't do is to raise the patient to elevated backrest. That has been the challenge for this project.

The Double Diamond model has been prominent through the whole project. Benchmarking by combining needs and metrics has been used to evaluate and compare the concepts.

Raising the patient to elevated backrest can in many cases be vital for the patient. It is also a more comfortable position for the patient. However, there are no medical rescue stretchers that are as versatile as the FG-stretcher while still having the ability to raise patients to elevated backrest.

The NAA has 13 helicopter bases spread over Norway. All of their bases are equipped with two types of stretchers. The Aerolite Cirrus stretcher [AC-stretcher], which for most bases is the primary stretcher, and the FG-stretcher. The FG-stretcher is used mainly for search and rescue missions, because of its high functionality in various terrain.

User insights in the beginning of the project laid a foundation of requirement specifications which later has been used to

compare and evaluate concepts. The first focus of the project was to find the mechanism that was best suited to meet the requirements. Prototypes were made to validate functionality and potential of the concepts. The concepts were carefully selected with the help of paramedics from both Norway and Switzerland. Weight estimations along with how the mechanism is operated, and how to secure it to the stretcher were also taken into consideration before settling on a final concept. The chosen concept for the lifting mechanism is a blockable gas spring. Detailing the concept required precise calculations of ideal angles and lengths to find the optimal gas spring.

After the concept for the lifting mechanism was chosen, a new ideation phase began. Finding the best way to attach the gas spring to the stretcher turned out to be another comprehensive product development process. Little space, strict requirements and several analyses are key words to this process. Several iterations later, two solutions are being presented through this report.

The two solutions are similar except from the way they are fastened to the original stretcher. The first solution attaches a brace permanently beneath the existing brackets and uses a quick release mechanism to connect the fixture to the brace.

The second solution is more easily removable and is fastened directly onto the existing brackets using a spring loaded latching mechanism.

SAMMENDRAG

Etter å ha etablert kontakt med Norsk Luftambulans (NAA), ble et prosjekt presentert som en potensiell masteroppgave. Prosjektet innebar å utvikle en ny fikstur for en av deres medisinske redningsbårer. Nærmere bestemt Franco Garda-båren. [FG-båren]. Dette er en lettvektig, solid, franskbygget bære ment for redningsoperasjoner i utfordrende terreng. Båren kan dras på alle underlag, og kan brukes i underhengende oppdrag fra helikopter. En funksjon den mangler derimot er muligheten for å heve pasienten til hevet ryggleie. Dette har vært utfordringen for dette prosjektet.

Double Diamond-modellen har vært fremtredende gjennom hele prosjektet. Benchmarking ved å kombinere behov og beregninger har blitt brukt for å evaluere og sammenligne konseptene.

Å heve pasienten til hevet ryggleie kan i mange tilfeller være livsviktig for pasienten. Det er også ofte en mer behagelig stilling for pasienten. Det er imidlertid ingen medisinske redningsbårer som er så allsidige som FG-båren, og samtidig har mulighet til å heve pasienter til hevet ryggleie.

NAA har 13 helikopterbasert spredt over Norge. Alle basene deres er utstyrt med to typer bårer. Aerolite Cirrus-båren [AC-båren], som for de fleste baser er primærbåren, og FG-båren. FG-båren brukes hovedsakelig til søk og redningsoppdrag på grunn av dens høye funksjonalitet i ulike terreng.

Brukerinnsikt i starten av prosjektet la grunnlaget for

kravspesifikasjoner som senere ble brukt til å vurdere og sammenligne konseptene. Prosjektets første fokus var å finne løftemekanismen som var best egnet for å oppfylle kravene. Prototyper ble laget for å validere funksjonalitet og anslå konseptenes potensial. Konseptene ble nøye utvalgt ved hjelp av ambulanspersonell fra både Norge og Sveits. Vektberegninger vurdert sammen med hvordan mekanismen betjenes, og hvordan man fester den til båren, ble også tatt i betraktning før et endelig konsept ble valgt. Det valgte konseptet for løftemekanismen er en blokkerbar gassfjær. Detaljering av konseptet krevde nøyaktige beregninger av ideelle vinkler og lengder for å finne den optimale gassfjæren.

Etter at konseptet for løftemekanismen ble valgt startet en ny idéfase. Å finne den beste måten å feste gassfjæren til båren viste seg å være enda en omfattende produktutviklingsprosess. Lite plass, strenge krav og flere runder med analyser er nøkkelford for denne prosessen. Flere iterasjoner senere presenteres to løsninger gjennom denne rapporten.

De to løsningene er like bortsett fra måten de er festet til den originale båren. Den første løsningen fester en avstiver permanent under de eksisterende brakettene, og bruker en hurtigutløsermekanisme for å koble resten av fiksturen til avstiveren.

Den andre løsningen har ingen permanente deler og festes direkte på de eksisterende brakettene ved hjelp av en fjærbelastet låsemekanisme.

TABLE OF CONTENTS

1. INTRODUCTION	1
1.1 Background	2
1.2 Problem definition	3
1.3 Disclaimer	4
2. PRODUCT DEVELOPMENT METHODOLOGY	5
2.1 Double Diamond	5
2.2 Storytelling	6
2.3 Snowball sampling method	6
3. INSIGHT	7
3.1 The Norwegian Air Ambulance	10
3.2 Importance of elevated backrest	14
3.3 The FG- stretcher	15
3.4 Users and way of use	19
3.5 Storyboard	21
3.6 Hoisting operations	23
3.7 Helicopter limitations	24

3.8 Competitor analysis	25
3.9 Possible improvements from user interviews	27
3.10 Requirement specification	29
3.11 Three different solutions	33
4. CONCEPT DEVELOPMENT	36
4.1 Parts for a new fixture	37
4.2 How to elevate the backrest?	38
4.3 Verification model	39
4.4 Initial sketches	43
4.6 concepts	47
4.6.1 Concept 1 - Fixed length	48
4.6.2 Concept 2 - Pulley system	49
4.6.3 Concept 3 - Sunbed	51
4.6.4 Concept 4 - Single centred gas spring	53
4.6.5. Concept 5 - Diagonal gas springs	56
4.6.6. Concept 6 - Telescopic twist	58
4.6.7 Concept 7 - Telescopic shovel	59
4.6.8 Concept 8 - Double gas springs	60
4.7 Preliminary calculations	64
4.7.1 8 concepts down to 4	68

4.8 Detailing the concepts	69
4.8.1 Detailing concept 1	71
4.8.2 Detailing concept 3 - Sunbed	75
4.8.3 Detailing concept 4 - Single centred gas spring	79
4.8.4 Detailing concept 5 - Diagonal gas springs	81
4.8.5 Weight estimates of the concepts	82
4.8.6 Concept evaluation	83
4.8.7 Detailing the final concept	87
4.9 Finding ideal angle and length of the gas spring	89
4.10 Choosing gas springs	91
4.11 Design of the backrest	93
4.12 Detailing the backrest	98
4.12.1 Composite materials	99
4.12.2 Emod of carbonfiber	100
5. PRODUCT DEVELOPMENT	103
5.1 Attaching the mechanism to the stretcher	104
5.2 Two concepts for brackets	114
5.2.1 Concept 1	117
5.2.2 Concept 2	118
5.3 Materials	121
5.4 Calculations for the gas spring	123

5.5. Calculations for estimate of cross section of braces	125
5.6 Calculations for the fastening mechanism	129
5.6.2 Fem analysis	133
5.6.3 Forces in FEM	133
5.6.4 Setups	134
5.6.5 Results of FEM	134
5.6.6 Results	135
6. FINAL CONCEPTS	138
6.1 Concept 1 - Permanent	139
6.2. Concept 2 - removable	143
7. DISCUSSION	147
7.1. Administrative challenges on the way	149
8. FURTHER WORK	150
9. REFERENCES	151

1. INTRODUCTION

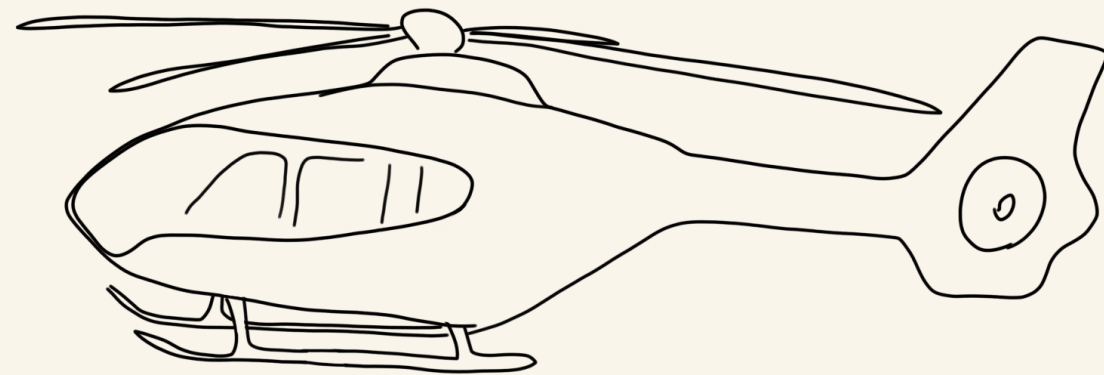

1.1 Background

This project has been developed after contact with Stiftelsen Norsk Luftambulans (SNL). The project will be a collaboration to solve a problem that has come to light during their service. The problem in question is a modification to one of the stretchers used in their service, and is not a direct mission devised by SNL.

When dealing with extreme conditions, especially in the Norwegian mountains, the regular stretcher may not be suitable. This raises the need for a stretcher capable of handling the harsh conditions. The stretcher made by Franco Garde aptly named the "Franco Garde stretcher" is made specifically for these kinds of conditions. The conditions in question are snowy terrain where the FG stretcher is able to sled along the snow, and rocky terrain where the structural integrity and toughness of the stretcher is being challenged. The official stretcher of SNL is not made for these conditions. It has not been approved for use in snowy condition and alpine rescue. To be able to provide a satisfactory service to people in need in the mountain regions, the personnel are replacing their regular stretcher with the FG stretcher.



Flat backrest

Figure 1. Illustration of the wanted functionality.

1.2 Problem definition

When substituting the regular stretcher for the FG stretcher a problem arises. The lack of ability to raise a patient to elevated backrest. This project aims to solve this problem. The project will indulge in an New Product Development (NPD) process focused on a given problem.

The fixture needs to be lightweight as the ambulance helicopters are always operating at the absolute limit of what is possible. The paramedics are in constant need to calculate the weight of the equipment carried, the fuel loaded and the weather conditions. When talking with the users, low weight came up as the most important criteria.

Furthermore, it needs to be tough and not buckle under the extreme conditions present in alpine rescue. Once installed, the fixture must be able to sustain heavy loads and vibrations without breaking or experiencing fatigue.

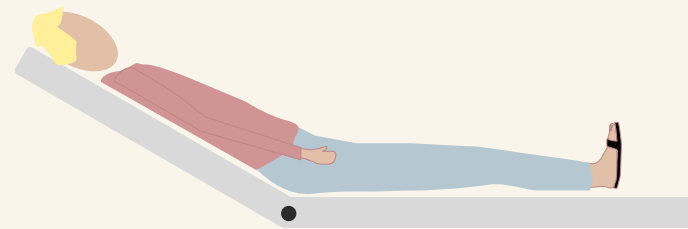

Elevated backrest

The last requirement is mobile as the amount of space in the helicopter is very limited. It also needs to be operated flawlessly in an easy manner regardless of the person using it. Since the equipment is made for alpine rescue and rough and unwieldy terrain, it is of great importance to be able to maneuver the stretcher with a fixture and patient with ease.

The problem that is to be solved can be summarized in the following sentence:
 "Development of a light, strong and mobile solution to accommodate elevated backrest in extreme conditions on a Franco Garda stretcher."

1.3 Disclaimer

The Franco Garda stretcher is used in SAR-missions. Doing modifications to the stretcher requires a new approval from EASA [European Union Aviation Safety Agency]. However, this will probably not be possible due to limited available funds.

Through the research it was clear that there are some requirements that must be met for a new fixture in the stretcher to be certified. Among these are requirements for flammability, a specific way to describe the whole rescue operation process, a number of G-forces the stretcher must endure, and a proper way to mount the stretcher to the floor inside the helicopter. These requirements are out of the scope for this project and will not be taken into consideration in the development of the new fixture.

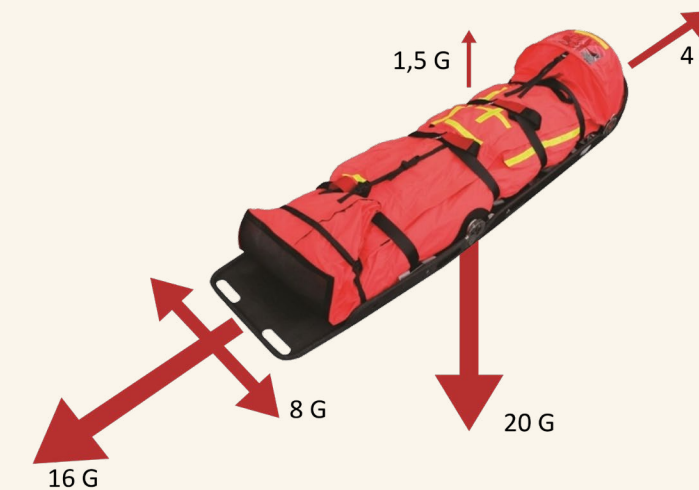

Figure 2. The stretcher has to endure 16G's forward, 20G's downwards, 8 G's sideways, 4G's backwards and 1,5 G's upwards

2. PRODUCT DEVELOPMENT METHODOLOGY

2.1 Double Diamond

The double diamond model has been prominent throughout the project. The model involves four phases; Discover, Define, Develop and Deliver, which often go many rounds as new insights occur and underlying problems become prominent. [DOGA, n.d.]

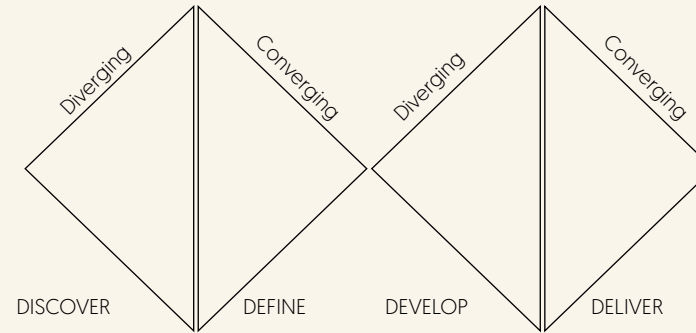

Figure 3. The Double Diamond model

DISCOVER

The discover phase is a diverging phase where the goal is to identify and understand the users and the challenges. This involved talking with the paramedics, and testing the current FG-stretcher.

DEFINE

The defining phase converges by analysing the insights and defining a focus area and limitations for the project. This resulted in a requirement specification.

DEVELOP

The develop phase is the start of the second diamond and is a diverging phase. In this phase the goal is to come up with different solutions that answers to the defined problem, and test them with users in order to find the best solution. Especially this phase goes through several iterations with prototyping and testing.

DELIVER

The deliver phase is a converging phase the goal is to make the final solution as good as possible and ready for production.

2.2 Storytelling

Storytelling is an interview technique. It is used by getting the interview object to tell about something as a story. This way, the person being interviewed will highlight areas of the story they think is most rememerable. This technique will often make the interview float better, and it is more likely to get insights of aspects the interviewer hadn't thought of him-/herself. [BB&CO, 2020]

2.3 Snowball sampling method

The snowball sampling method is a method used to recruit new units. [Simkus, 2023]. For this project the units are interview objects. The method was used by asking at the end of every interview if there are any other relevant people that would be valuable to talk to. This method can be a way to get access to several people pretty quickly because you get a way in by referring to the person that sent you.

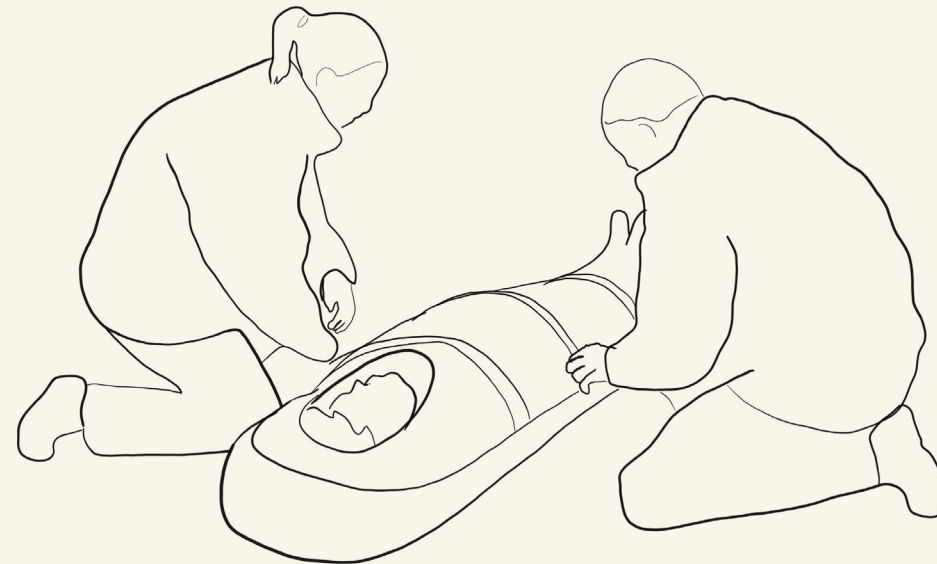

3. INSIGHT

The insight section of this thesis builds on the foundation made by Høiseth in the course TMM4560 [Høiseth, 2022]. In the aforementioned thesis the insight phase could not be finished due to a lack of interviews. Based on this, parts of the methodology may need to be altered as more insight is gained.

The insight phase of the given project heavily revolved around interviews. Finding interview object was done by contacting several people working in NAA, along with people working in NARG and the 330 Squadron. Interviews with corresponding prosecutors in other countries were also done. Especially REGA, the SAR service in Switzerland has contributed a lot. Reaching out to rescuers working with SAR on LinkedIn has also provided good insight. Certain aspects were not possible to find anywhere else. The snowball sampling method was used to find more interview objects. This method provided a way into a group of stakeholders that normally are very busy and can be hard to get in touch with. It resulted in highly relevant interviews.

The interviews were often started using a storytelling method. Interview objects were for example asked if they could describe a “normal” rescue mission. Normal in quotation marks since there really are no normal missions. Using storytelling lets the interview objects themselves guide the conversation, and they will often highlight the aspects they perceive as most important. They are also more likely to mention details that the interviewer hadn't thought of.

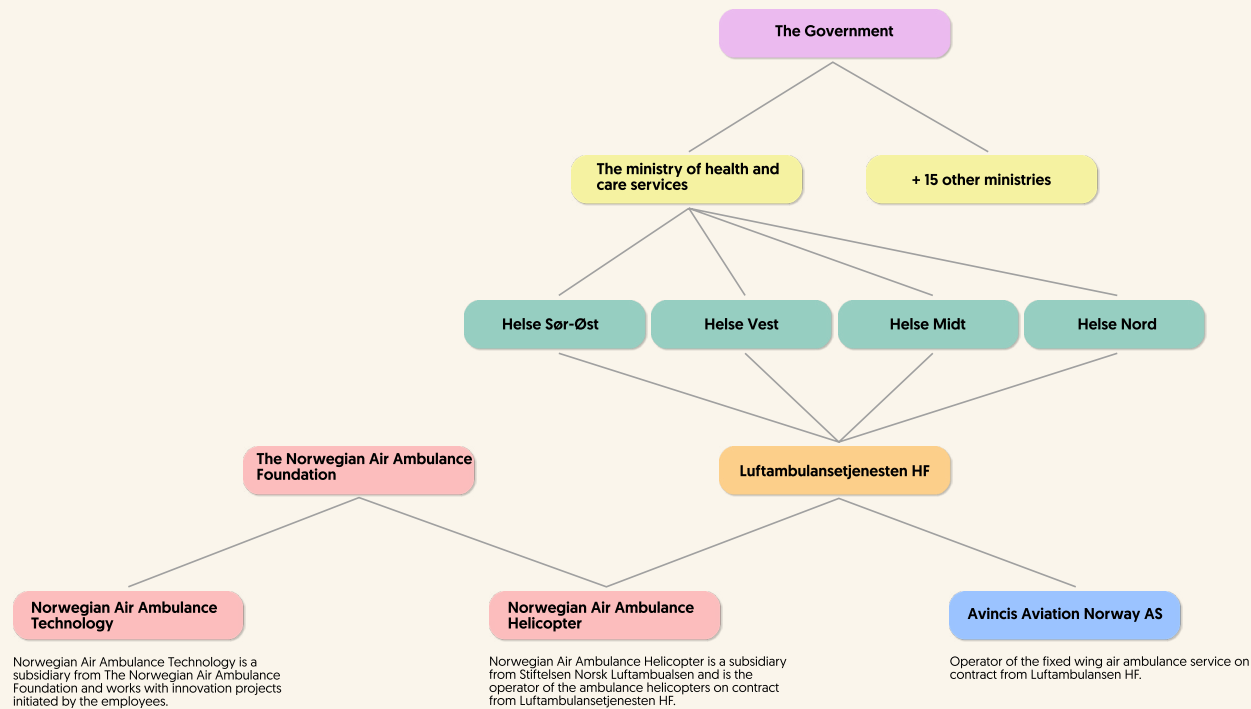

Figure 4. System overview over the air ambulance service in Norway. [Luftambulansen, 2022a]

3.1 The Norwegian Air Ambulance

The Norwegian Air Ambulance [NAA] is an ideal organization founded in 1977. Their goal is to provide faster and better medical assistance to anyone who is ill or severely hurt, anywhere in Norway. The funds they receive from supporters and companies are spent on innovation, training and skill development.

There is an agreement between the Ministry of Health and Care and the Ministry of Justice and Public Security that lets them use each other's resources when there is need. The Ministry of Justice and Public Security has contract with three companies. The 330 Squadron from the Royal Norwegian Air Force, Lufttransport AS and CHC Helicopter Service. This means that NAA can get assistance in e.g. Search and Research-missions [SAR]. This cooperation leads to a good spread of bases all over Norway. Norske Alpine Redningsgrupper [NARG] will also assist when needed.

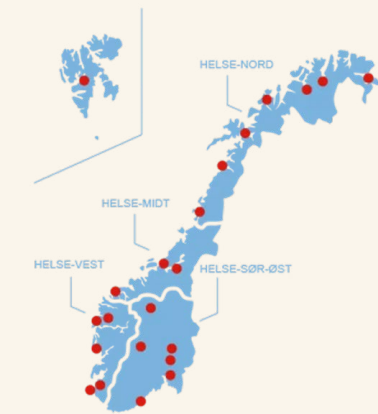

Figure 5. Overview over regional health authorities and bases. This map includes the bases operated by the cooperation partners. [Luftambulansen, 2022b]. The NAA also operates four bases in Denmark as part of their service.



The Norwegian Air Ambulance



Airbus H135
Located in Dombås, Førde, Lørenskog, Stavanger and Ål



Airbus H145
Located in Bergen, Brønnøysund, Harstad, Kirkenes, Lørenskog and Trondheim



Leonardo AW139
Located in Tromsø and Ålesund



330 Squadron



SAR Queen
Located in Banak, Bodø and Sola



Sea King
Located in Rygge and Ørland



CHC Helicopter service



AWSAR Super Puma
Located in Florø



Sikorsky S-92A
Located in Tromsø



Luftransport AS



AWSAR Super Puma
Located in Svalbard

Figure 6. Overview over different prosecutors and their helicopters.

The NAA are primarily involved in three types of missions.

1. Primary missions:
Acute sickness and injuries where the patient needs transport to the hospital. These are the most common missions for the helicopters.
2. Secondary missions:
Moving a patient from one hospital to another higher level hospital. These are the most common missions for the fixed wing aircrafts.
3. Return missions:
Transport the patient back from the bigger hospitals to the local ones for finishing treatment. These missions are common for both helicopters and fixed wing aircrafts.

In addition to this the helicopters do SAR missions. About 8% of all helicopter missions are SAR-missions. [Luftambulansen, 2023]

Figure x illustrates how many missions of each type the NAA had with helicopters in 2021. In total there were 19 554 missions, divided between ambulance helicopter (7 949), fixed wing aircrafts (8 771) and rescue helicopters (1 089). The remaining 1 745 are missions that were aborted due to different circumstances. [Luftambulansetjenesten, 2022]

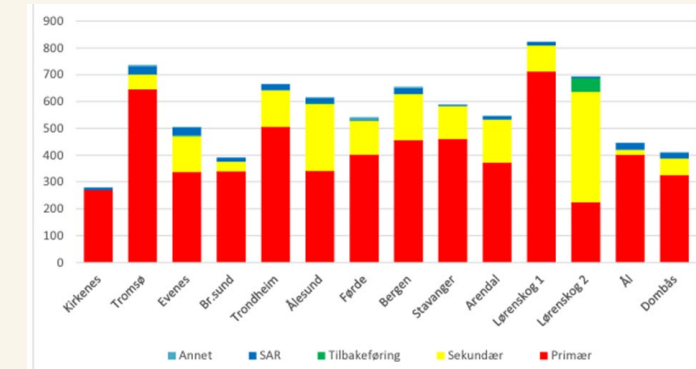

Figure 7. Types of missions for rescue helicopter missions in 2021. [Luftambulansetjenesten, 2022].

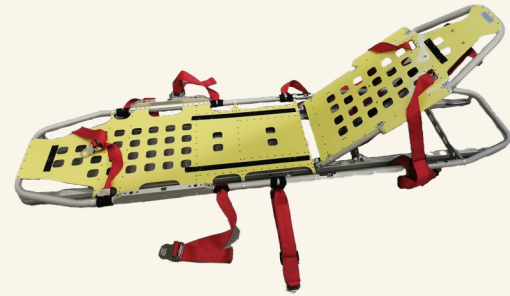

Figure 8. The Aerolite Cirrus stretcher



Figure 9. The Franco Garda stretcher

The NAA uses two different stretchers. The Aerolite Cirrus [AC] and the Franco Garda [FG] stretcher, shown without vacuum mattress and rescue bag in the images below. All but two bases uses the Cirrus as their primary stretcher, while Dombås and Ål only uses the FG-stretcher. The reason for this is that they both have the H135 helicopter, which is the smallest one, and therefore has limited cargo weight capacity. The bases are also located in mountain areas, and most of their missions are in challenging terrain where the Franco Garda stretcher performs better than the stretcher from aerolite. Adding the number of

rescue missions in Dombås and Ål gives an estimate of how frequently the stretcher is in use. The stretcher is used primarily for primary- and SAR missions, which for 2021 adds up to an estimate of $350 + 425 = 775$ missions. Since these two bases uses the FG as their primary stretcher, they are the bases in Norway with the most experience with this stretcher.

3.2 Importance of elevated backrest

The insight phase started by finding out what elevated backrest is, why it is important and when it is used. Høiseith had already investigated this through his work in [course]. The clinical term for elevated backrest is Fowler's position. [Vera, 2023] This position is in most cases preferred by the patients, and they often ask if they can lay more upright. In other cases, it is a choice the anesthetist makes in order to increase the patient's chance of survival. Some examples are if the patient has problems with the heart, problems breathing, head injuries or experience nausea.

By elevating the back, the heart will be relieved, breathing will be easier, which further will reduce nausea. If the patient has head injuries, it is desirable to reduce the blood pressure in the head. To put it another way there are few cases where the patients should lay flat, apart from back injuries.

- Fowler's position
- High [45°-90°]
 - Semi [30°-45°]
 - Low [15°-45°]

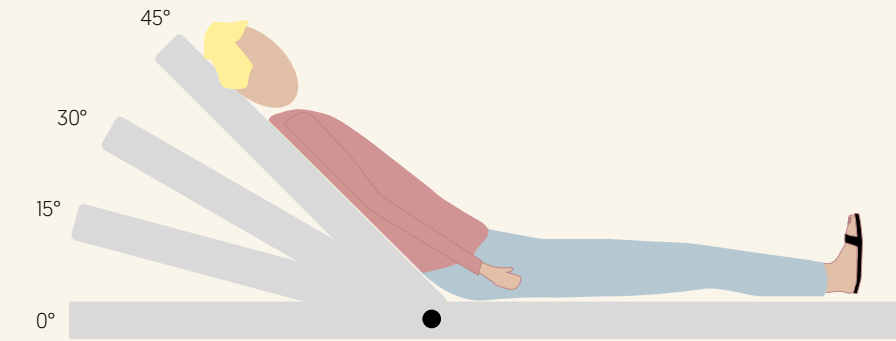

Figure 10. Fowler's position

3.3 The FG- stretcher

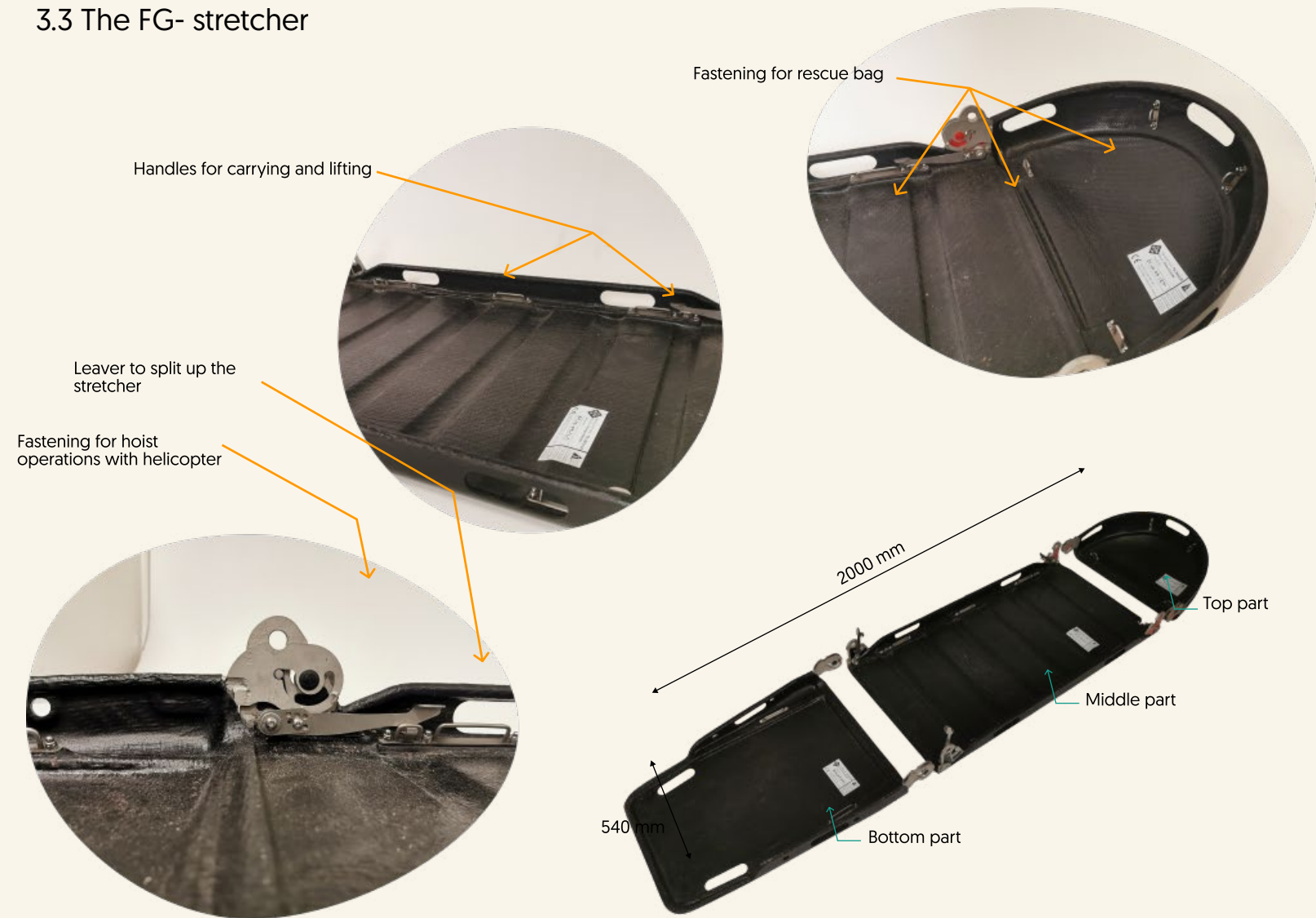

Figure 11. Details of the FG-stretcher



Figure 12. Details of the rescuebag in the FG-stretcher



Figure 13. The FG-stretcher folded. Image from [Borgen & Strand, 2022].

The design of the FG-stretcher makes it possible to use in all environments. From dragging it around in hotel halls to rocky hills. It can be dragged, pushed, lifted and sometimes put on top of the hospitals medical stretcher to stroll it around. It has also been used in hoist operations, in which it performs very well. Depending on the injury the patient can lay on its back, on the side or on the stomach. Laying on the stomach is very rare, while on the side and back is common.

The producer also offers various accessories for the stretcher. E.g., an anti-rotation rudder used to reduce spin during hoisting operations.

Made by TSL in France in cooperation with the French PGHM police and the military. On their website they highlight the ability to fold the stretcher and carry it as a backpack. This feature however has never been used by any of the interview participants. When mentioned they exclaim that the feature could be more valuable to rescuers that needs to climb or rappel to access the patient.



Figure 14. Parts of the rescuebag.



Figure 15. Closeup of how the rescuebag strap is fastened to the bracket.

The yellow straps are secured to the rescue bag by having the strap double layered at each side. The strap is thread through the brackets and over the patients body. It thereby secures both the rescuebag to the stretcher and the patient to the stretcher in one operation.

The headrest in the rescue bag is secured to the stretcher as shown in the images to the right using a rubber strap.

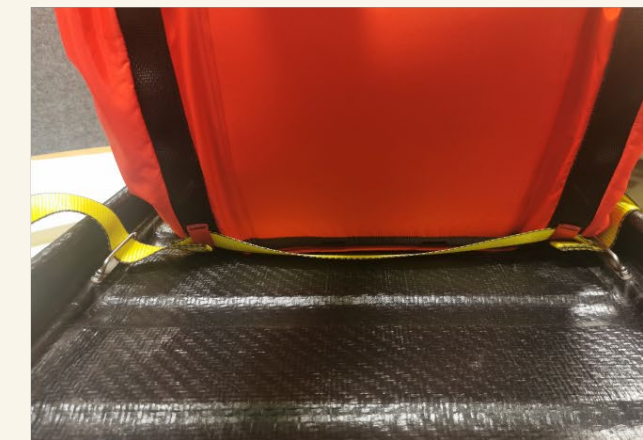

Figure 16. Closeup of how the head part of the rescuebag is fastened to the bracket.



3.4 Users and way of use

For a medical rescue stretcher paramedics will be the primary users, and patients will be secondary users. The paramedics are the ones operating and handling the stretcher and are also the ones deciding how the patient should lay in the stretcher. The patients are of course important to take into consideration as well. A more upright position will often feel more comfortable for the back and will also give them a better overview of their surroundings. This can help calm them down, which is positive in any stressful situation.



Role: Rescuer
Task: Rescuing and accessing the patient + medical support. The rescuer has a medical background and works closely with the anaesthetist. He or she is also seated next to the pilot in the front seats and is co-pilot with responsibility for the navigation and communication with the 113- central and other prosecutors.

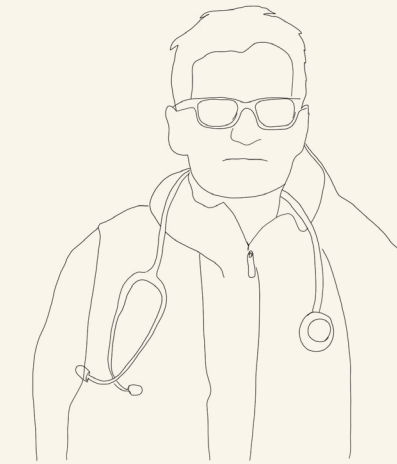

Role: Anaesthetist
Task: Helping the patient. Medical expertise with specialization in anaesthesia and pain management. Sits in the back of the helicopter together with the patient.



Role: Pilot
Task: Main task of flying the helicopter. Will also assist the anaesthetist and rescuer if the treatment takes time and the helicopter can turn off the engine.

3.5 Storyboard

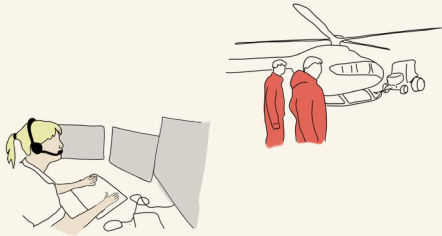

Call centre receives an emergency call

The 113- call centre receives a call and decides the best possible way to help. The call centre contact NAA and can also contact NARG or the 330 Squadron if needed.

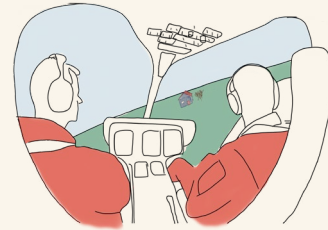

The helicopter is dispatched

In flight, trying to locate the patient. The 113-call centre keeps them updated with new information along the way.



Doing whatever must be done before the patient can be lifted into the helicopter

Helicopter lands as close to the patient as possible. If it easy access to the patient the anaesthetist is first to the the patient. The rescuer brings the stretcher. The pilot is ready to assist if needed. The patient is normally put on the stretcher and dragged or lifted back to the helicopter.



The patient is lifted into the helicopter

The stretcher is loaded into the helicopter from the back. Because of the low height the stretcher needs to lay flat. The stretcher is mounted to the floor with straps. Equipment might have to be left behind and retrieved later depending on the patient's weight.



During the flight to the hospital the anaesthetist has good overview over the patient

When inside the backrest can be elevated if wanted/needed. The anaesthetist sits beside the patient facing either forwards or backwards. The rescuer in front can assist during the flight by handing equipment or medicaments. Everybody in the helicopter, including the patient, is wearing headsets and can communicate.



Arriving at the hospital

When arriving at the hospital there are nurses and doctors ready to take over. If the paramedics have the time, they will follow the patient in to the operation room and share medical information directly to the physician. This reduces the risk of information being lost in transfer with the nurse. If they have another mission they will share the info with the nurse when they hand over the patient.

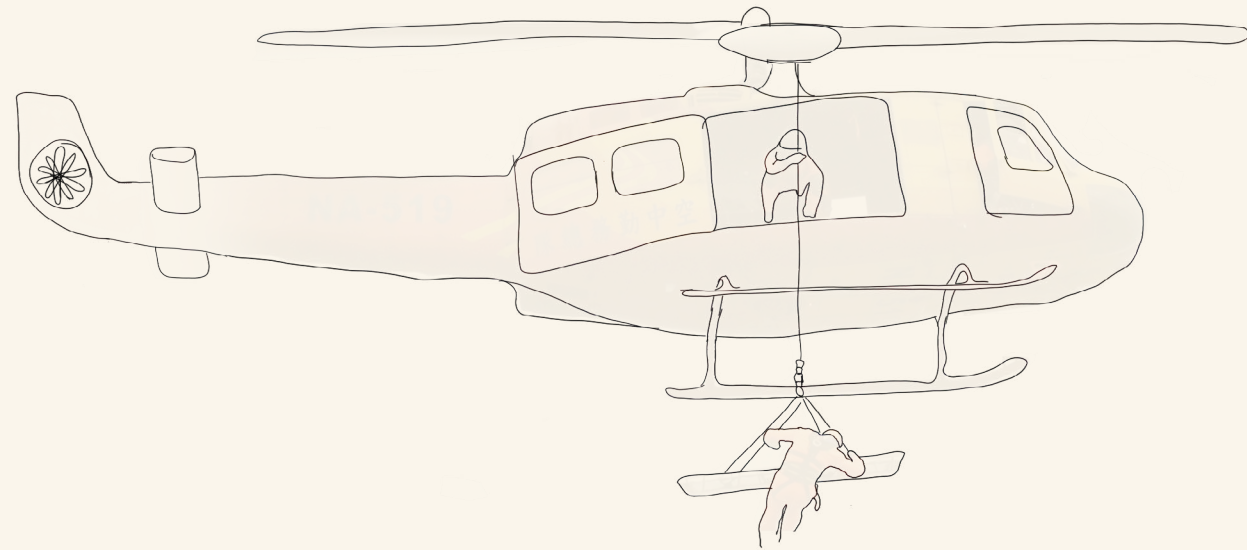

3.6 Hoisting operations

The stretcher has previously been used for hoisting operations in Norway. A hoisting operation is used when there aren't any good locations to land the helicopter. The rescuer is hoisted down to the patient along with the stretcher. The patient is put on the stretcher and hoisted back up into the helicopter. The FG-stretcher excelled at this. In comparison to the rescue bag that is

used today, the stretcher was more stable against uneven weight distribution. It also gave more protection around the patient's head and body in general, and was less prone to rotation from the helicopter rotors.



3.7 Helicopter limitations

The helicopters that the NAA uses are relatively small. Especially the Airbus H135 has very limited space and cargo capacity. In some missions they have to let equipment behind in order to fly the patient safely to the hospital. This is the main reason for the "Low weight"- requirement. If the fixture is too heavy, it won't be brought with in the helicopter. It has been clear from the very beginning of the project and is based on the helicopter's cargo capacity.

While the helicopter is on the ground the rescuer can assist the anaesthetist in elevating the patient by using the door on the left-hand side. From the seat position, the anaesthetist has good overview and access over the patient. It was important not to restrict this access when developing a new concept.

3.8 Competitor analysis

The base in Ål is not the only ones not having a solution for the problem. Through the competitor analysis no direct competitors were discovered. There exists stretchers that solves parts of the problem, but none that are meant for the same usage. By reaching out to talkative paramedics from different parts of the world on LinkedIn and using the snowball sampling method, the closest competitor was found. An ex US Marine now working with rescue and safety equipment had just designed such a fixture on a rescue stretcher. This stretcher is made for rescue in water and is not suitable to be used as a sled on snow and rocks. There is currently no information about this additional equipment to the stretcher they are selling.

Can see there currently are no lightweight stretcher meant for rescue in challenging terrain that also has the ability to adjust the angle of the backrest. The Franco Garda will be the first stretcher in this segment when the fixture is developed.

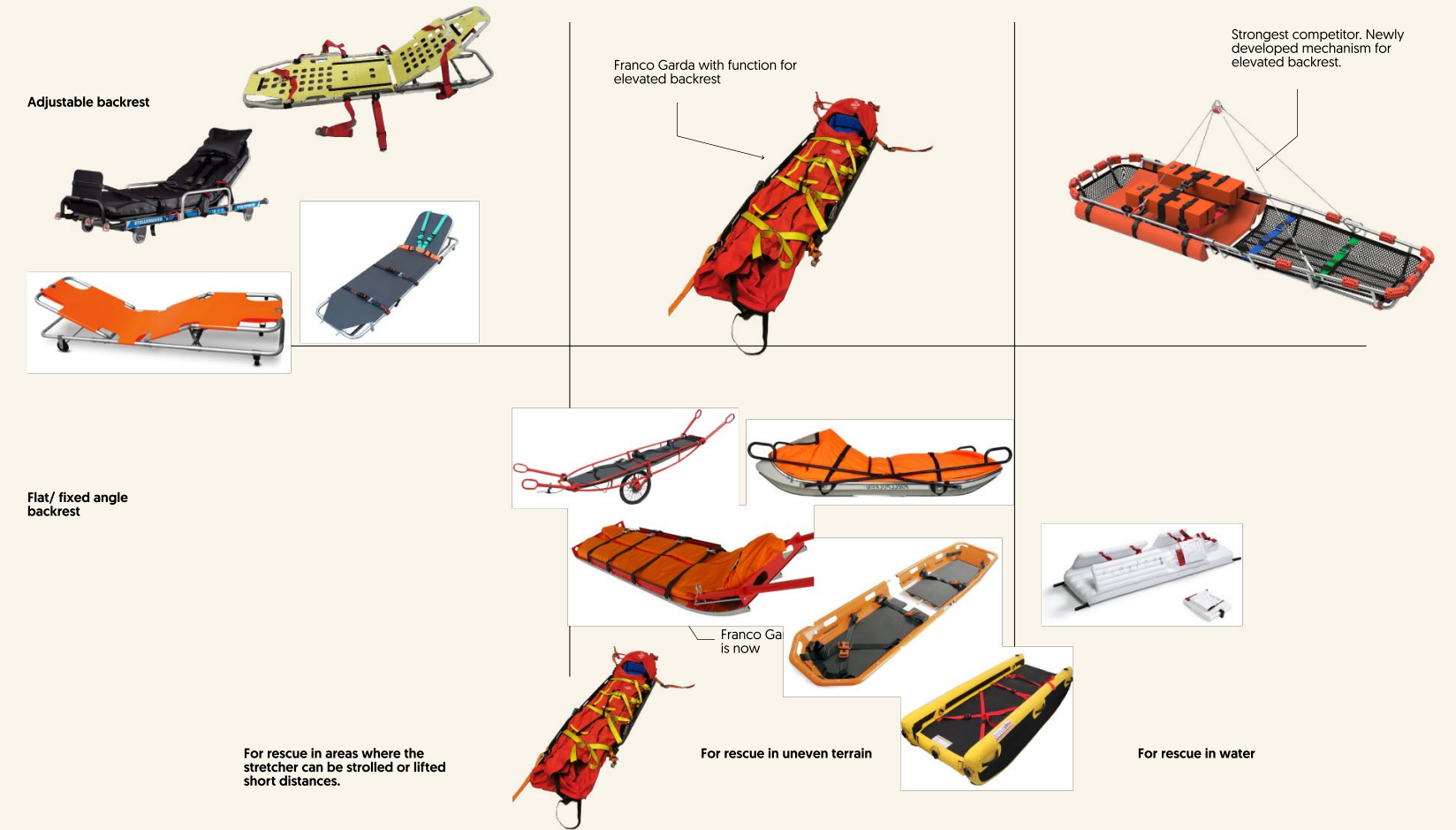

Figure 17. Competior analysis.

3.9 Possible improvements from user interviews

Lack of information sharing

From the very beginning of the insight phase, it was clear that the problem at hand was well known and was experienced by many. The rescuers were very happy someone wanted to do something about it, and prioritized time for long, valuable interviews. One of the first big findings was a lack of communication between bases in Norway. Although the problem at hand is well known, paramedics at the base in Dombås and in Ål haven't talked with each other about how to solve it. In Dombås they have made a temporary solution with a metal plate and a solution comparable to the function of a sunbed. Paramedics in Ål had not heard of anyone having a solution for the problem, and are stuffing backpacks, duvets and pillows behind the patient's back.



Figure 18. A temporary solution for elevating the patients back. Rescue boards are put in the back and supported by medical backpacks. Photo: Martin Samdal.

Høiseth had already made a requirement specification through his preliminary work. He had however not been able to get insight from users. During the interviews the new insights resulted in an adjustment in the relevance of some of the original product needs, and a couple of new needs were added to the requirement specification. The importance of quick assembly and disassembly grew based on the need to fit patients of all sizes. Due to the limited lifting capacity of the helicopters, the backrest function might have to be removed to save weight if the patient is heavy. In addition, the need for being able to lock the stretcher at any given angle was less important than first assumed. One interview object stated that "it would be nice to be able to lock halfway up, but no need for more than that" upon asked about the locking ability. Another stated that the ability to lock at any angle is nice, but far from necessary. The most important part is having the ability to raise the back to roughly 30 degrees. Furthermore, every single interview object complained about the ergonomics of the stretcher's carrying handles.

Other aspects that came from interviewing paramedics are:

- The handles for carrying the stretchers are sharp. Carriers must use gloves.
- Being able to put the patient in elevated backrest is necessary.
- Some indication of how many degrees the patient is elevated to would be good to have.
- Could be nice to have more options to fasten ropes and secure the patient with.
- Could be a better system for how to secure the patient in the vacuum bag. There are a lot of straps now.
- Sometimes it could be nice with a bigger windscreen protecting the patient's face.

In addition to these physical improvements a possible

improvement of the practice was discovered. The improvement is based on the practice in REGA in Switzerland. When the rescue helicopter lands at the hospital with a patient, the hospital is ready. The hospitals always have a spare vacuum mattress. When they arrive with a patient, they hand over the patient on the vacuum mattress it's already laying on and receive the spare vacuum mattress. This way they don't have to move the patient unnecessarily, both saving time and sparing the patient for excessive discomfort. Saving time means they can faster get in the air again and be ready for the next mission. The hospitals in Norway are ready when the helicopter lands as well, but there they don't have a spare mattress. This practice is something that is highlighted by rescuers at REGA and would likely be beneficial also in other countries such as Norway.

3.10 Requirement specification

#	Needs	Relevance
1	Low weight	•••••
2	Easily maneuverable size	••••
3	Easy to install and remove	••••
4	Easy to operate when installed	•••••
5	Can achieve at least 30°	•••••
6	Can be used in multiple stretchers	•
7	Can handle high stress and vibrations	•••••
8	Can fit all patients regardless of size	••••
9	Can be used in different temperatures	•••••
10	Can lock at a given angle	••
11	Long lifespan	•••
12	Assisted lifting	••
13	Mechanism does not move in rough terrain	•••••
14	Ergonomics	•••
15	Certification for use	•••••
16	Can be folded with the stretcher	•
17	Legal fastening of stretcher to helicopter	•
18	Better straps to secure the patient in the stretcher	N/A
19	Smooth operating. [No sudden movements]	•

Table 1: Overview of the needs required for the fixture to be considered successful. Relevance is rated from 1-5 where higher is better.

Need 18 is not applicable because it's out of the scope of the project.
 Need #3 increased, while need#10 decreased one level of relevance.
 Need 14- 19 are new needs discovered after talking with paramedics.

The metrics should be measurable and used to describe the needs in a good way. In Table 2 the metrics gets bound up to the needs (column 2) affected. The relevance ranking is based on how relevant the metric is to satisfy the needs of the customer. The product specifications must contain a metric and a value for use. i.e., "must achieve a minimum of 30°". Therefore, it is possible to define ranges for the metrics after learning the customer needs. This helps front loading the project in order to have as much of the important decisions early in the process as possible [Ulrich, Eppinger, Yang, & Ulrich, 2020]. A more direct link between the needs and metrics is shown in Table 3.

Metrics #	Needs #	Product specification [Metrics]	Relevance	Unit
1	1, 3, 4	Weight of fixture	•••••	kg
2	5, 14	Maximum angle achievable	•••••	deg
3	2, 16	Height when fully collapsed	•••	mm
4	2, 3, 14, 19	Setup time	•••	sek
5	2, 3, 16	Assemble and disassembly time	•••	sek
6	9, 15	Minimal function temperature	••••	°C
7	9, 15	Maximum functional temperature	••	°C
8	1, 7, 9, 11, 13, 15	Materials	••••	*
9	4, 7, 14, 19	Force needed to activate the mechanism	••	N
10	7, 10, 13, 15, 19	Maximum force the mechanism can withstand	••••	N
11	8, 12, 15	Minimum weight of patient	••	kg
12	7, 8, 12, 15	Maximum weight of patient	••••	kg
13	8	Minimum height of patient	••	mm
14	8	Maximum height of patient	•••	mm
15	4, 7, 13, 14, 19	Ability to lock at any angle	•	**
16	6	Universal fastening for multiple stretchers	•	***
17	2, 4, 6, 8, 14	Area of back support	••	mm ²
18	2, 3, 6, 8, 14	Distance from hinge to top of the headrest	•••	mm
19	2, 3, 6, 8, 14	Width of backrest	••	mm

Table 2: Overview of metrics for the fixture based and compared to the needs given in Table 1. Relevance is rated from 1-5 where higher is better.

* The choice of materials in this table refers to what material is chosen as opposed to its mechanical properties.
 ** Ability to lock at any angle refers to whether the mechanism have the feature or not.
 *** Universal fastening for multiple stretchers refers to whether the fixture have a universal design or not.

#	Need	Metric																		
		1	2	3	4	5	6	7	8	9	10	11	12	13	14	15	16	17	18	19
		Weight of fixture	Maximum angle achievable	Height when fully collapsed	Setup time	Assembly and disassembly time	Minimal function temperature	Maximum functional temperature	Materials	Force needed to activate mechanism	Maximum force mechanism can withstand	Minimum weight of patient	Maximum weight of patient	Minimum height of patient	Maximum height of patient	Ability to lock at any angle	Universal fastening for multiple stretchers	Area of back support	Distance from hinge to top of headrest	Width of backrest
1	Low weight	*							*											
2	Easily manoeuvrable size			*	*	*												*	*	*
3	Easy to install and remove	*			*	*													*	*
4	Easy to operate when installed	*								*						*		*		
5	Can achieve at least 30°		*																	
6	Can be used in multiple stretchers															*	*	*	*	*
7	Can handle high stress and vibrations								*	*	*	*			*					
8	Can fit all patients regardless of size											*	*	*	*			*	*	*
9	Can be used in different temperatures					*	*	*												
10	Can lock at a given angle									*										
11	Long lifespan								*											
12	Assisted lifting											*	*							
13	Mechanism does not move in rough terrain								*	*					*					
14	Ergonomics								*						*			*	*	*
15	Certification for use	*		*		*	*	*	*	*	*	*								
16	Can be folded with the stretcher		*		*															
17	Legal fastening of stretcher to helicopter														*			*	*	*
18	Better straps to secure patient																			
19	Smooth operating. (No sudden movements)			*					*	*					*					

Table 3: Table showing the correspondence of the different needs and metrics. Based on data given in Table 2

As the process moves along, and the sets are being explored, the tables presented above will serve as a great validation tool and guide for selection. Developing the matrixes and specification ranges will greatly help monitoring the status of the project, as well as how the different solutions compare to each other. Using the benchmarking frequently in the set-based approach and implementing them in each stage gate will streamline the decision-making process. During the stage gates the ranges of values for the metrics can be directly compared. Using the relevance ranking it is possible to weight the results to have an objective evaluation of the entire set. Thus, removing the designers bias, and focus on what satisfies the customer in the best possible way.

3.11 Three different solutions

From the insights that were gained through user interviews it was clear that the task of improving the stretcher could be differentiated in three different time perspectives with varying comprehensiveness.

A short-term solution

The first solution would be to improve the current FG-stretcher by developing a fixture to accommodate elevated backrest, as was the initial task. This is a short-term solution because it only addresses one of the problems discovered in the insight phase. It also doesn't take into consideration the requirements to make the stretcher certified. This solution would solve the problem initially asked by the NAA, but the stretcher would probably not be certified with the new fixture.

A mid-term solution

The second solution would be to improve the stretcher according to the findings from user insights. Along with developing a function to accommodate elevated backrest this would include to improve the ergonomics of the stretcher and find out what needs to be changed in order to make the stretcher certified for both normal use and in HHO (Helicopter Hoist Operations).

A long-term solution

A long-term solution would be to design a completely new stretcher specifically for the Norwegian Air Ambulance based on a combination of the good aspects of the Franco Garda stretcher and the users' wanted improvements. One of the finds from the

user interviews was that none of the rescuers has ever utilized the stretchers' ability to be folded. When the stretcher is built up by three individual pieces all the pieces must be excessively strong not to be a weak spot when the parts are put together. Removing this feature could therefore save a lot of weight.

The way the stretcher is made now is by having a steel frame around the outer edges and a sandwich glass fiber composite in between. The middle part also has foam laid across to stiffen up the stretcher. It would be interesting to look at where geometry and topology optimization would prioritize material. Doing this could potentially allow for the use of a lighter material than steel and could potentially save some weight.

Ergonomics would be a focus area for a new stretcher as well. The paramedics have especially mentioned the carrying handles to be very sharp, and impossible to use without gloves if there is a patient on the stretcher.

The new stretcher would of course be developed according to standards and meet all demands so it would be certified. This would e.g., involve choosing a non-flammable material as e.g., carbon fibre, a glass fibre/NOMEX composite or a thermoformed polycarbonate as suggested by Aerolite.

Fastening points would be strategically put to accommodate both elevated backrest and hoisting operations. This reduces the need for an excessively large metal bracket to support the elevated backrest mechanism.

The chosen solution

Although developing the elevated backrest function was the initial task, there are other improvements that could be made to reduce stress for the paramedics as well. However, due to limited time it wouldn't be possible to develop and build a completely new stretcher. The mid-term solution is therefore regarded as the solution that will be most beneficial for the Norwegian Air Ambulance given the available resources. The project goal is therefore changed to develop a function to accommodate elevated backrest, as well as improve ergonomics and getting the stretcher a lot closer to be certified for permanent use.

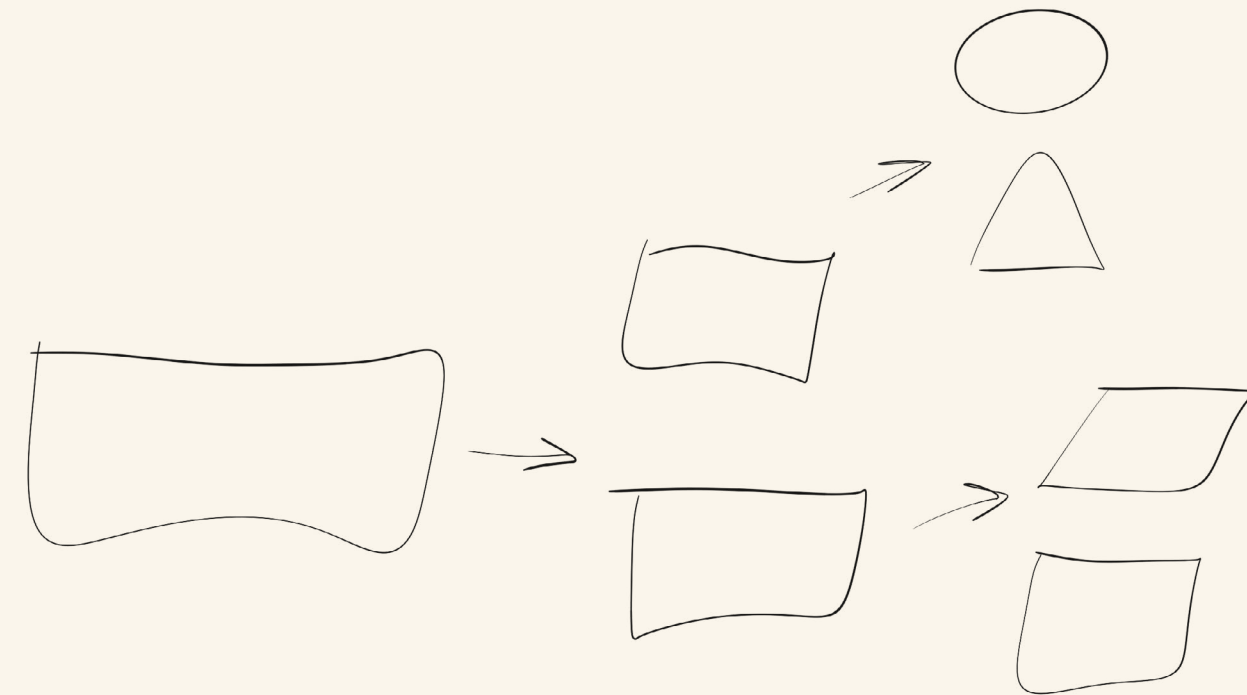

4. CONCEPT DEVELOPMENT

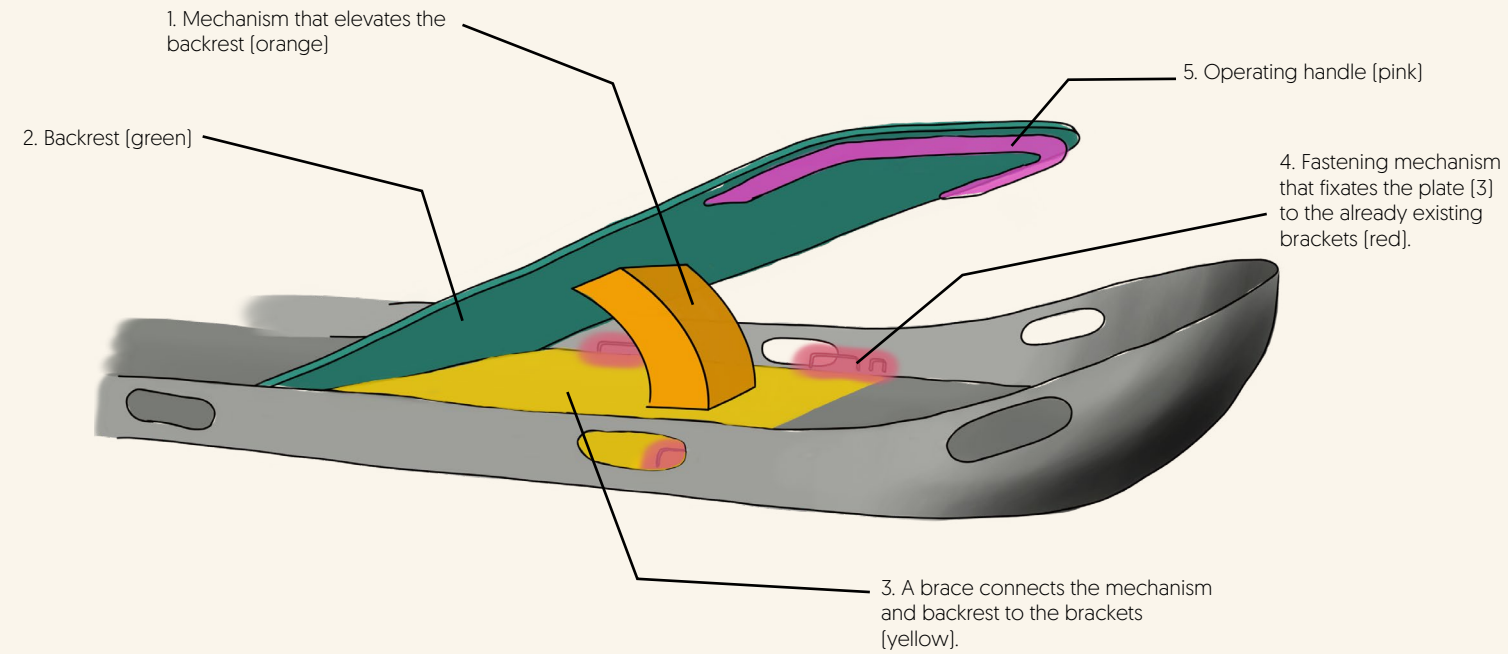

4.1 Parts for a new fixture

Figure 19. Parts for a new fixture
The different parts are in this illustration colored to be easily differentiated. The exact location and designs are to be determined through the project.

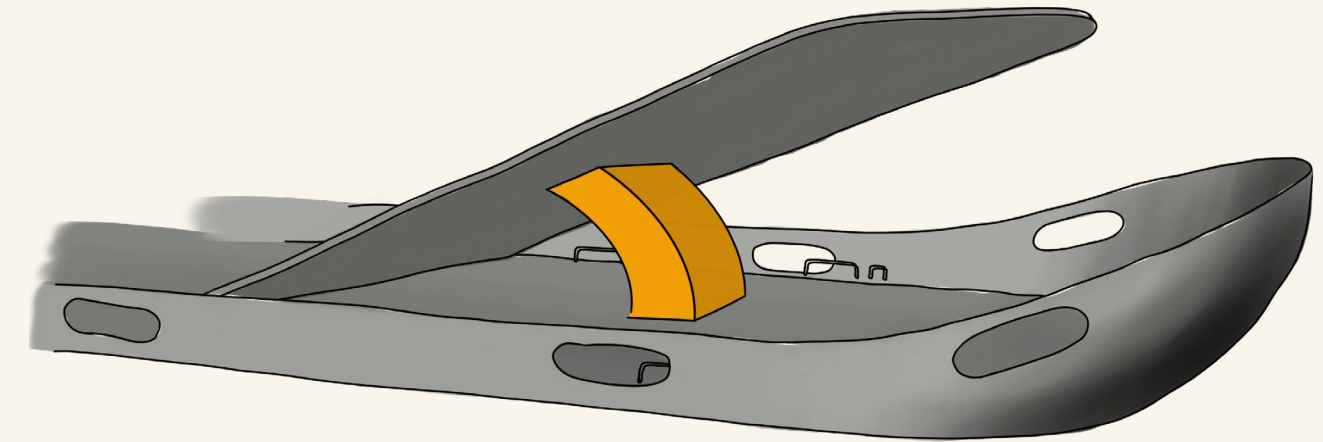

Figure 20. Working with the lifting mechanism.

4.2 How to elevate the backrest?

Designing the mechanism that elevates the backrest was regarded as the main challenge for this project. As the design of the remaining parts [part 2, 3, 4 and 5] are depending on this mechanism, it was natural to solve this challenge first.

4.3 Verification model

In order to develop a fixture accommodated to the FG-stretcher, it was needed to have accurate measurements of the stretcher and especially the fastening brackets. One restriction for the project was not to make any new holes or other structural changes in the stretcher, because that could weaken its properties. This meant that any additional fixture had to use the existing fastening points.

As none of the ambulance bases has an spare FG-stretcher, the solution was to build one. Through the fall of 2022, Høiseith was working on his preliminary project for this master thesis, and Borgen and Strand were working on their D9 project on the same task. As both were in need of the measurements of the stretcher, the base in Trondheim were kind to lend the stretcher for a week during the fall in 2022. Visiting the base also kickstarted the insight phase. One of the paramedics gave a full tour of the H145 helicopter and demonstrated both the AC- and the FG- stretcher.

The FG-stretcher was complicated to measure accurately as thicknesses varies alot through the whole stretcher. The measurements of the brackets are the most important thing to get correct, as any new fixture has to be secured in them. The brackets were also especially hard to measure correctly as they are angled. The top part of the stretcher has a complex curvature that is hard to measure and replicate accurately. Especially the fastening points are tricky as they are put in composite angles. A verification tool was made to ensure the measurements were correct. The verification tool has 3D-printed parts that fits accurately on the brackets thought to be useful for a fastening a new fixture. Between the 3D-printed parts there are profiles of plywood.

The idea with the verification tool was to validate that the brackets were correctly placed in the 3D-model. If the tool fits onto the brackets in the original FG-stretcher, it would also fit future fixtures based on the measurements in the 3d-model.



Figure 21. Validation tool in the FG-stretcher.

Due to lack of access to the FG-stretcher, a mockup was made. The mockup is a simple 1:1 scale replica of the stretcher, but with high precision on the brackets. The thought was to have a model that could be used to receive immediate feedback for prototypes.

Through Borgen & Strand's project in D9 in the fall of 2022, a similar mockup had been made as they were working on the same problem. It was desirable to reuse as much as possible from their D9 project, but as this project required a higher level of precision, most of the mockup was unfit for the project. It was both easier and faster to build the mockup from scratch than to do modifications on their mockup. The only thing used from their stretcher is the plywood backrest.

Metal brackets were cut, bent and welded to replicate the original ones, and mounted on the mockup with high precision. The validation tool was again used to control that the brackets were mounted at the correct locations.

The bottom part of the FG-stretcher was not made due to its insignificance for the concept development.

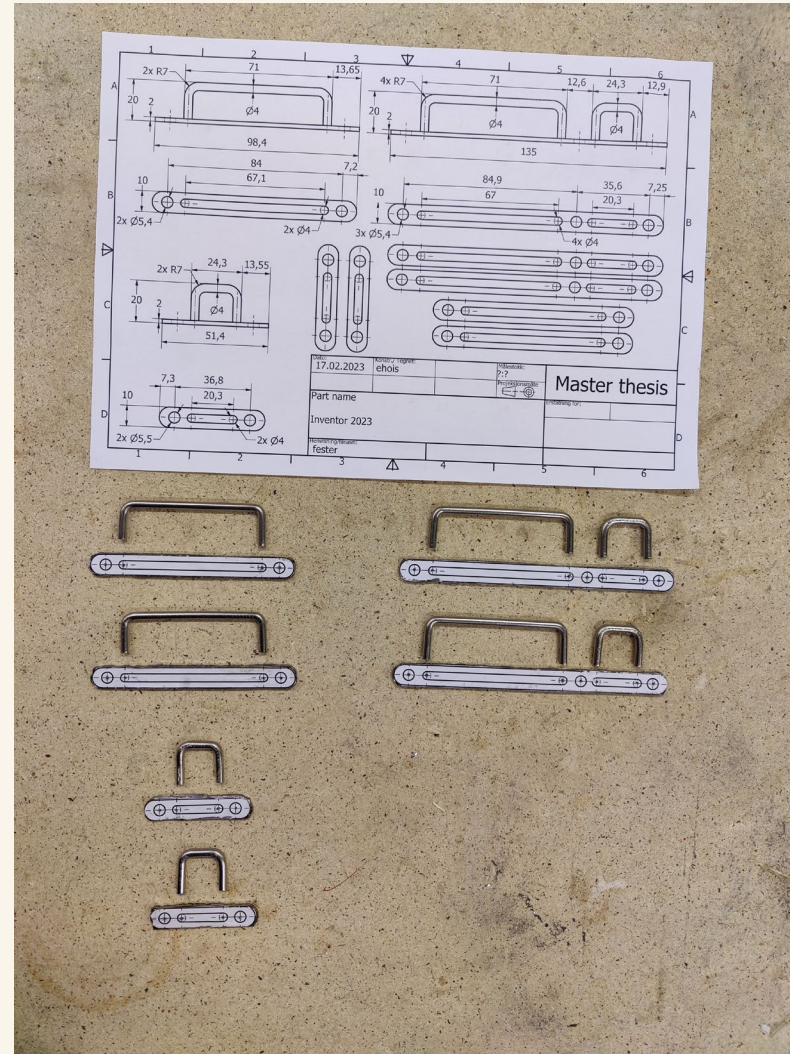

Figure 21. Technical drawings and replicated steel brackets.

The middle part was produced in plywood. Plywood was chosen due to its structural properties. Crucial aspects for the middle part are the angle of the fastening points and the geometry of the plate. Transverse braces stiffen the plate. On the FG-stretcher we lent the braces had a bit varying distance between them. The distance varied from 30 mm to 50 mm. A thought was to utilize this immersion to make the mechanism flatter.

As the positioning of the brackets were the most important aspect, a 3D-printed structure were made to get the angles correct. This 3D-printed part is for verification and visualization only. It is not strong enough for physical testing.



Figure 22. The mockup with the reused backrest from Borgen and Strand's D9 project.

Figure 23-25. Validation tool in the mockup. Verifying that the brackets are correctly mounted.

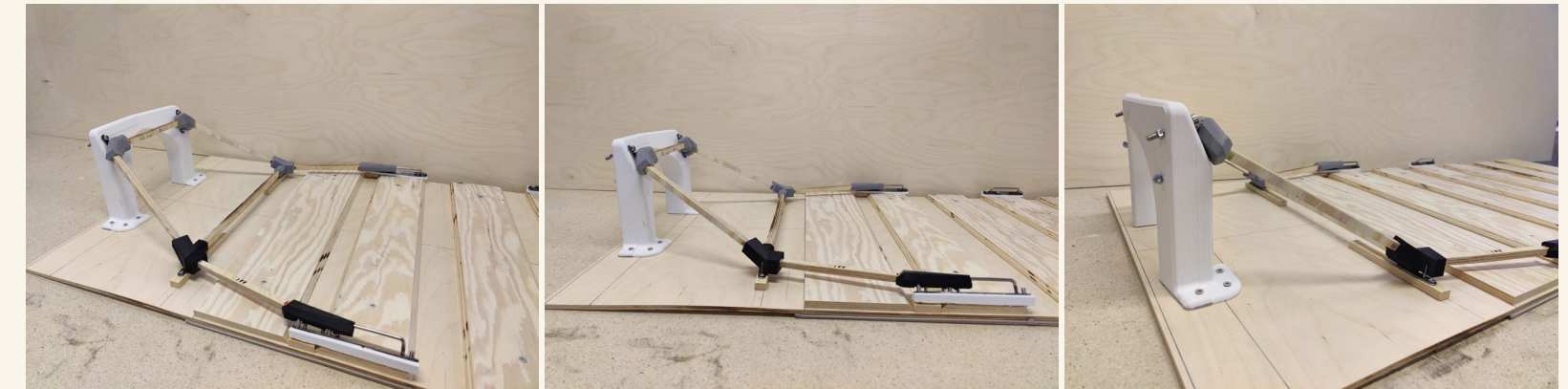

4.4 Initial sketches

The concept development phase started by brainstorming and sketching out ideas for mechanisms that would adjust the angle of the backrest.

Fixed length profile with slider in the bottom.

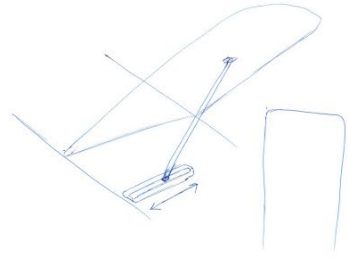

Pulley in the roof

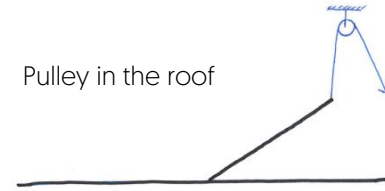

Exped Chair kit inspired straps. Two step operation.

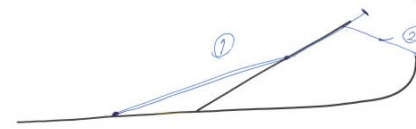

Inspired by a sunbed

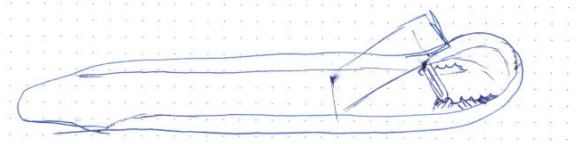

Flaps hinged at the bottom

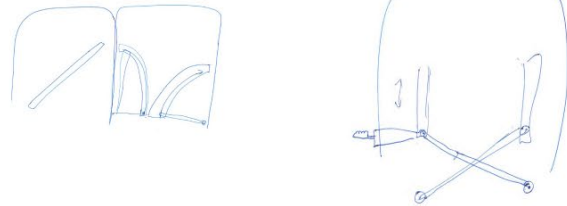

Flaps hinged in the bottom

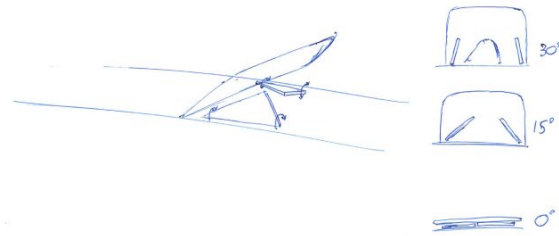

Inflatable pillow with angles of 15 and 30 degrees

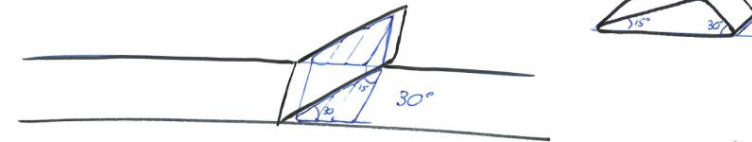

Telescopic

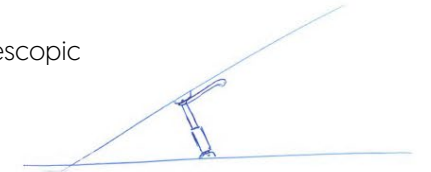

Advantageous to elevate the legs at the same time?



Twist to lock

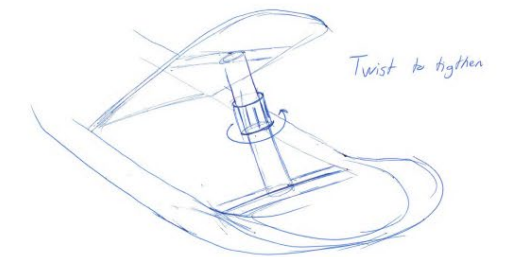

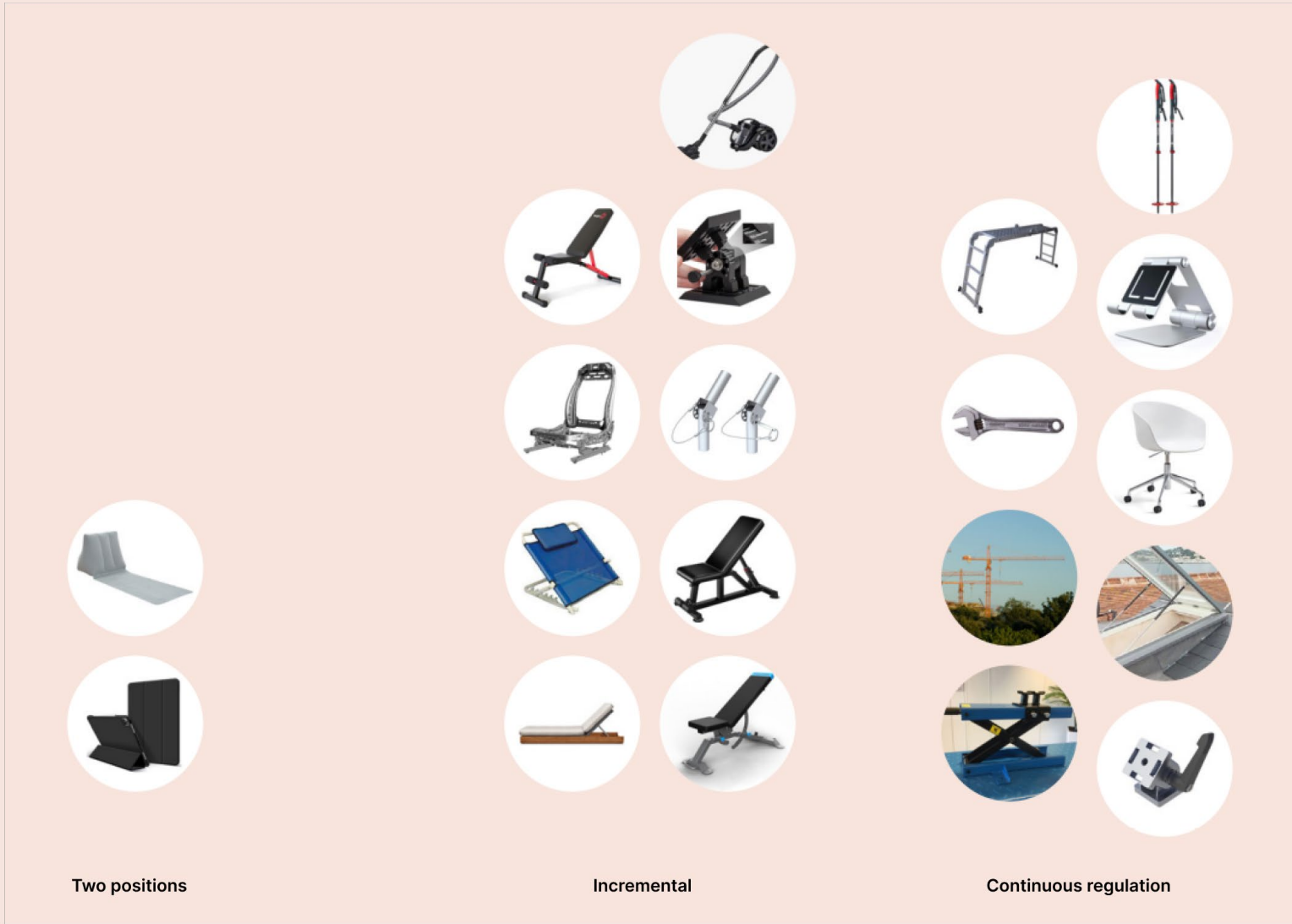

After initial ideas were sketched out on paper, the participants split up and looked at similar mechanisms that adjusts the angle of a profile or the way two profiles are put together. Borgen & Strand also did a similar session to gather inspiration. They illustrated it nicely in their report by categorizing the mechanisms into three groups depending on the number of possible steps.

Figure 26. Comparison of mechanisms that adjusts an angle. Illustration from [Borgen & Strand, 2022].

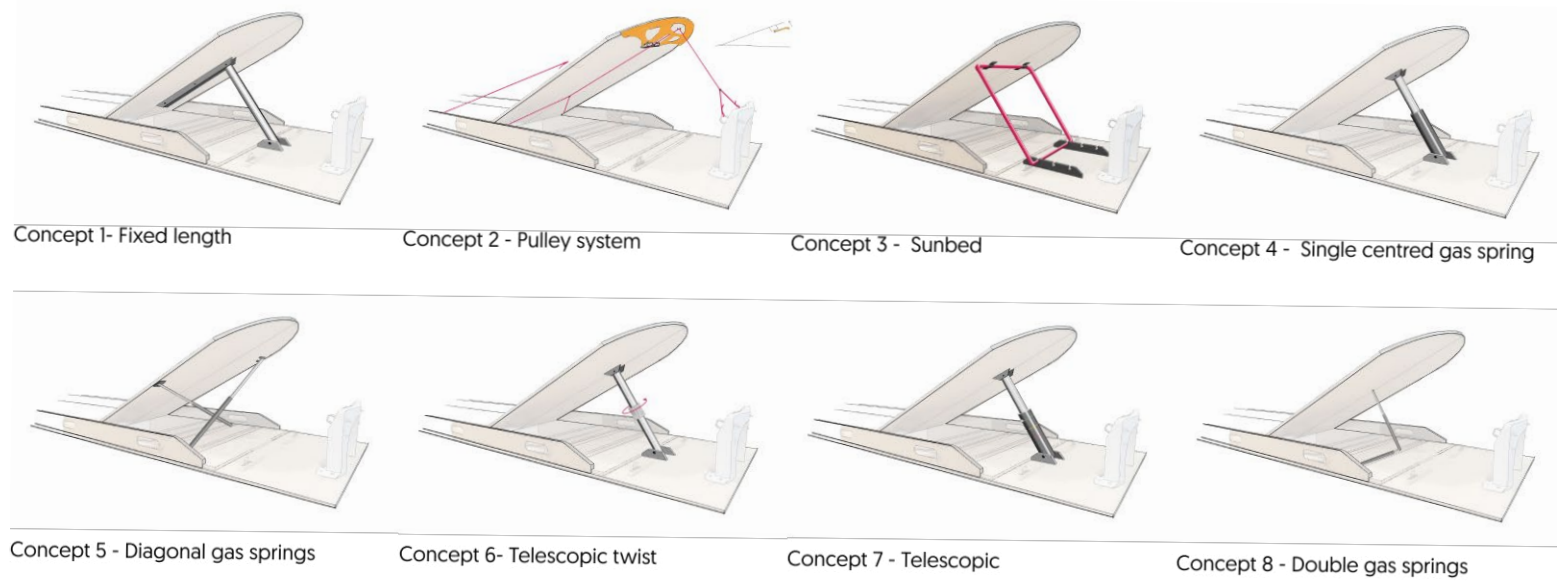

Figure 27. The 8 most promising concepts from the first ideation round.

4.6 concepts

The result of this brainstorming session were 8 concepts. These concepts were elaborated on, and prototyped till a level sufficient for further evaluation and comparison.

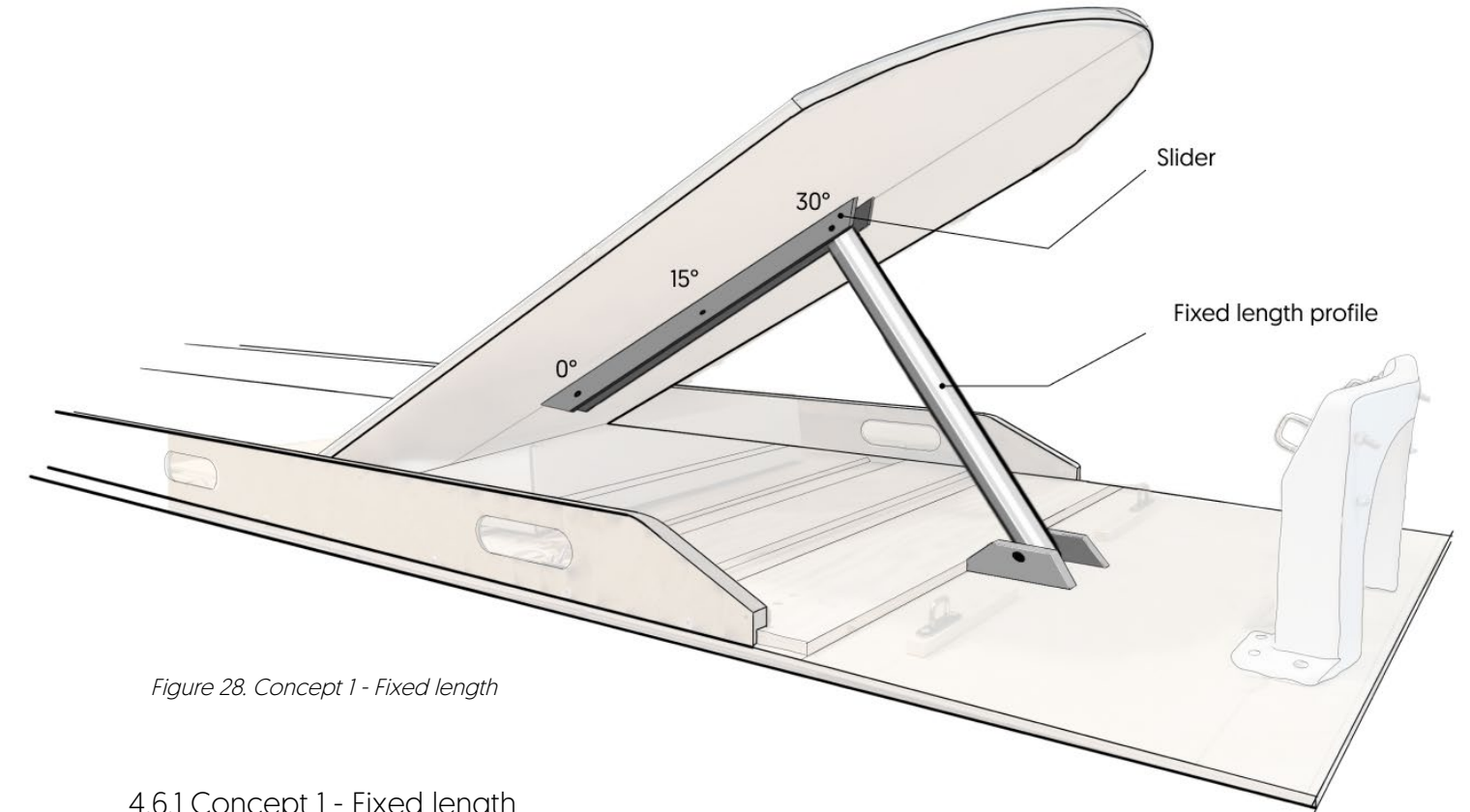

Figure 28. Concept 1 - Fixed length

4.6.1 Concept 1 - Fixed length

This concept consists of a fixed length profile that adjusts the angle of the backrest by being locked into different holes in the slider.

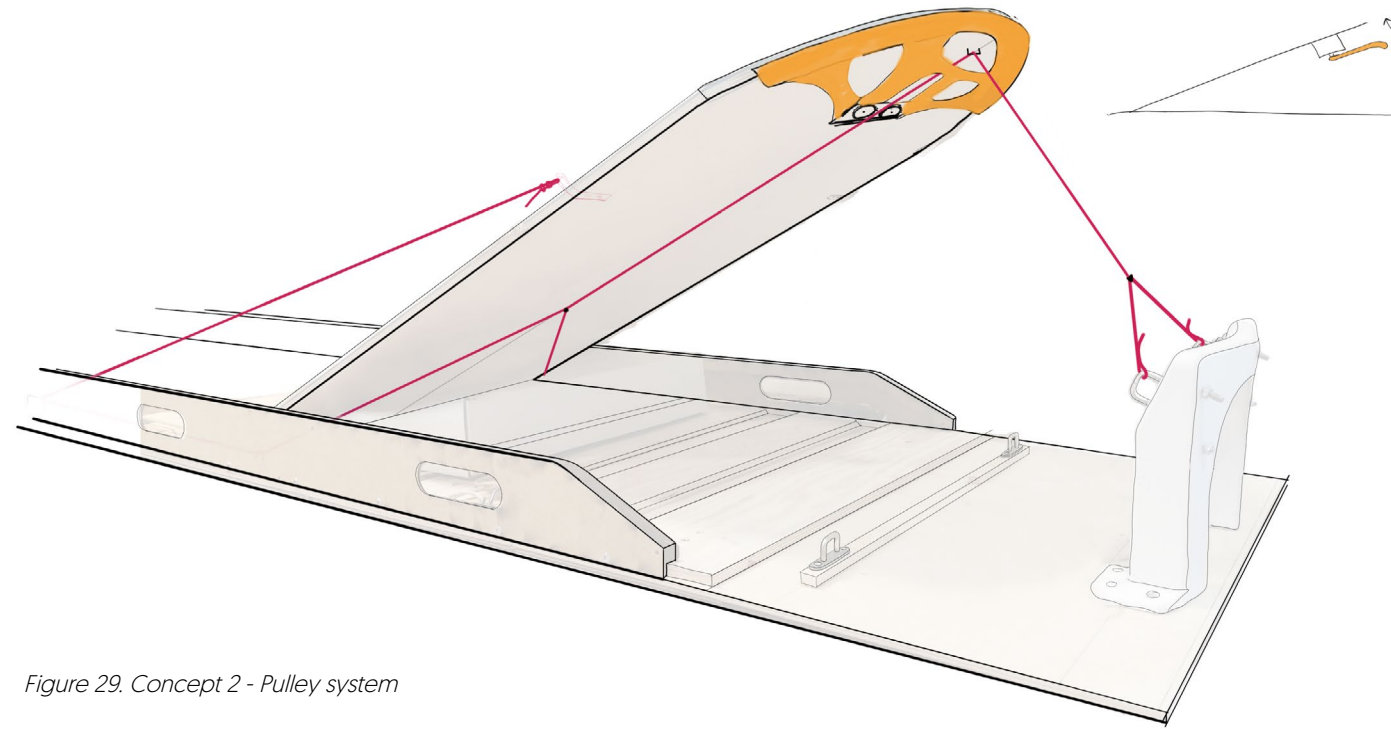

Figure 29. Concept 2 - Pulley system

4.6.2 Concept 2 - Pulley system

Inspired by the adjustment of the Exped Chair Kit. kilde. The concept was first sketched as a two step operation, operating two pulley systems. The first system elevates the backrest, while the second pulls the backrest down towards the back of the stretcher's head protection. This way the backrest is prevented from bouncing neither up or down.

It was tried to turn the two step operation into a one step operation by having several pulley wheels in one system. The thought was to create a system that is always tensioned. By adjusting how much wire is on either side of the backrest, the angle of the backrest could be adjusted.

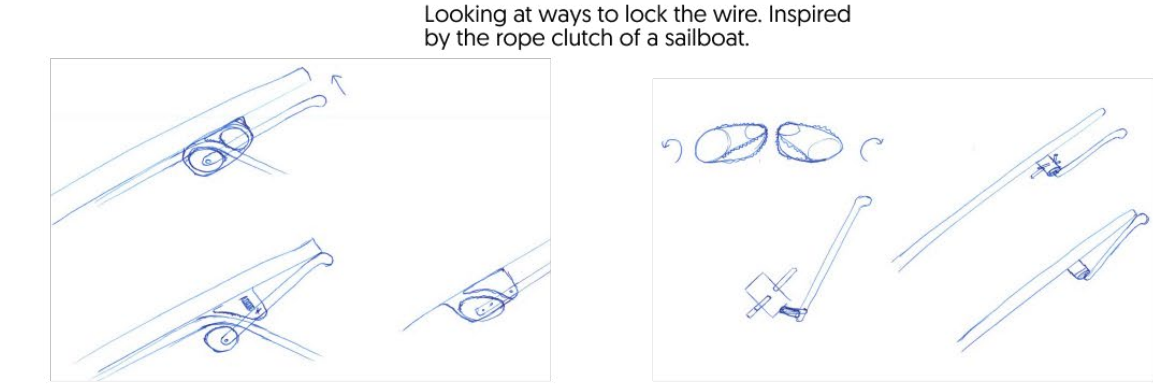
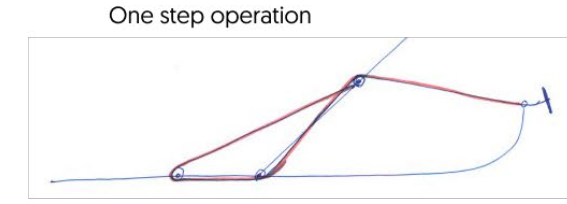
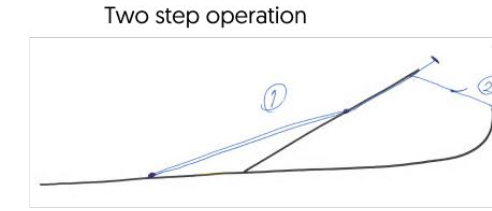

Figure 30-32. Prototype of concept 2.



Prototype with rope and a 3D-printed pulley.



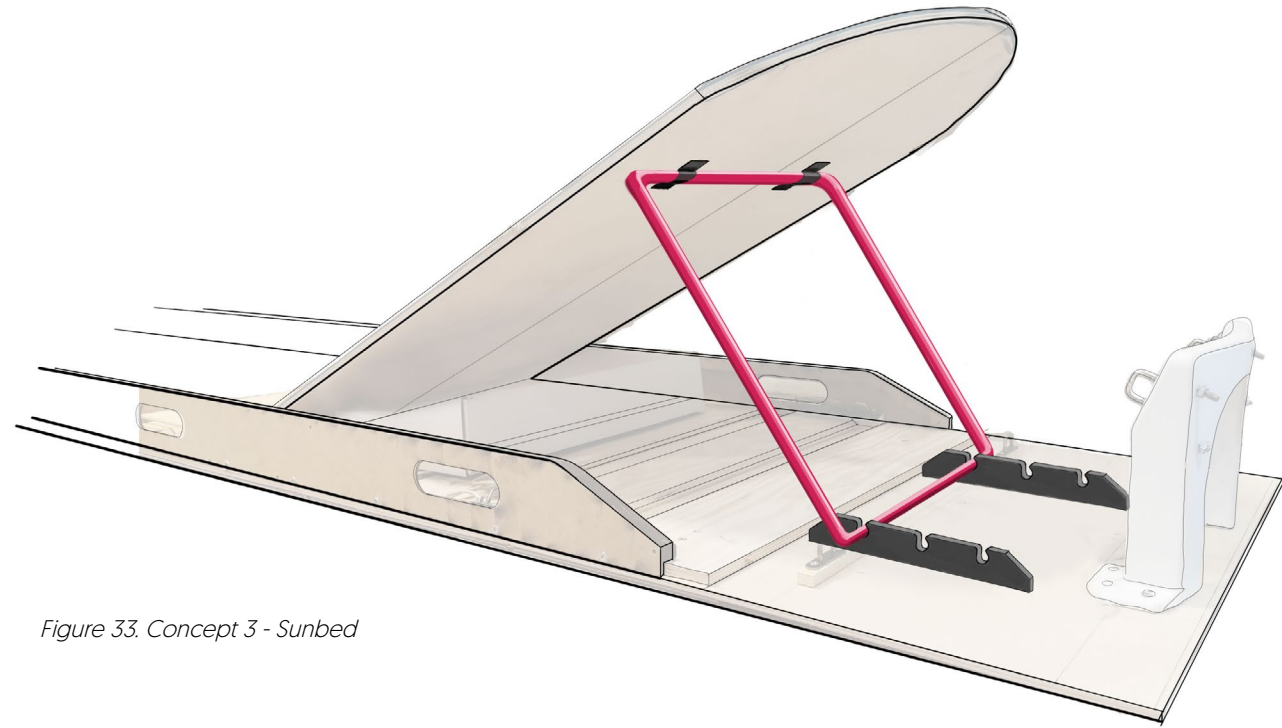

Figure 33. Concept 3 - Sunbed

4.6.3 Concept 3 - Sunbed

This is a familiar and well tested concept inspired by a sunbed. It is stable, simple and easily understandable. However, there are some challenges. Compared to the simple adjusting mechanism of a sunbed, this mechanism needs a positive lock to prevent the backrest from bouncing up in uneven terrain. The mechanism must also be possible to operate, even when the backrest is flat.

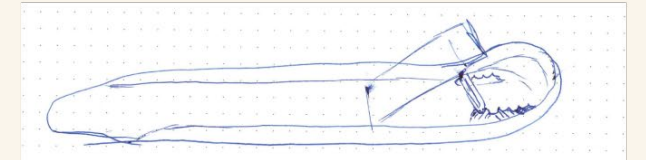

Figure 34-36 Prototype of concept 3.





Figure 37. Concept 4 - Single centred gas spring

4.6.4 Concept 4 - Single centred gas spring

Using a gas spring to elevated the backrest is a familiar idea. Most medical stretchers that can elevate the backrest use a gas spring. The initial thought was, as the sketch implies, to have the gas spring angled perpendicular to the backrest as this would maximize the force of the gas spring. This is however not possible.

The fastening point at the backrest is thought to be in the gravitational centre of the human body. This is 500 mm from the hinge. The minimum distance the gas spring can be fastened to point B is either point C or D. Version 2 and 3 illustrates roughly what it would look like.

How flat the backrest would be in its lowest position is indicated by angle α . As illustrated, version 3 would have the lowest angle.

There is some uncertainty to exactly where point E would be located. If it is too far from the hinge, it would run out of space on the middle plate of the stretcher which is negative. Both the hinge and the fastening for the gas spring will probably be fastened to a H- bracket. The bracket will be strongest if the distance from point E isn't too far from the hinge.

The gas spring is strongest when it's perpendicular to the backrest. Angle α indicates the angle between the gas spring and the perpendicular line. The lower the angle, the better angle for the gas spring. Version 3 has a much lower angle α than version 2.

A gas spring with length $2x + y$ fastened in point A can't be fastened in point C. The closest it can be is either in point D or E. This is because the distance BC is shorter than $x+y$.

The total length of the gas spring can be described as $2x + y$. x is the length of the extended cylinder and y is the distance the two cylinders are overlapping when it's fully extended.

Figure 38. Two possible positions for the gas spring.

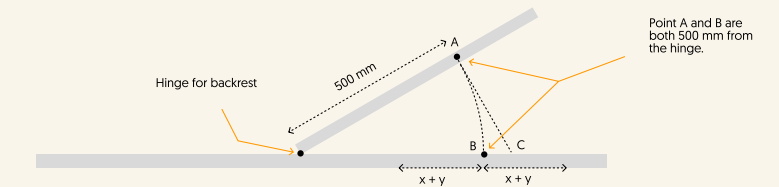

Version 1 - Fastened in point B

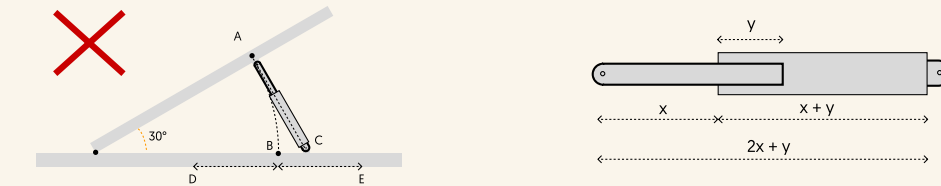

Version 2 - Fastened in point D

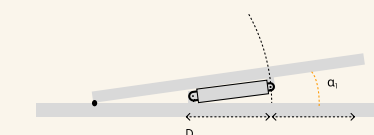
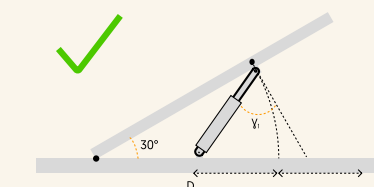

Version 3 - Fastened in point E

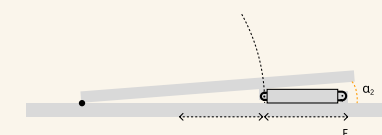
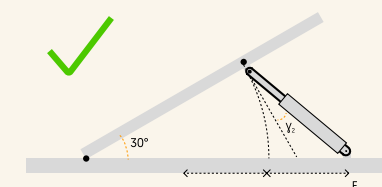

Point E in Version 3 was thought to be too long away from the hinge to be possible to secure in the existing brackets. The prototype was therefore made using the Version 2 setup.

Small temporary fastening mechanism that could be screwed into the prototype were cut, bent and welded to steel tubes to create a simulation of a gas spring.



Figure 39. Prototype of the gas spring.

[Video demonstration of the concept](#)



Figure 40-41. Prototype of the gas spring in the mockup.

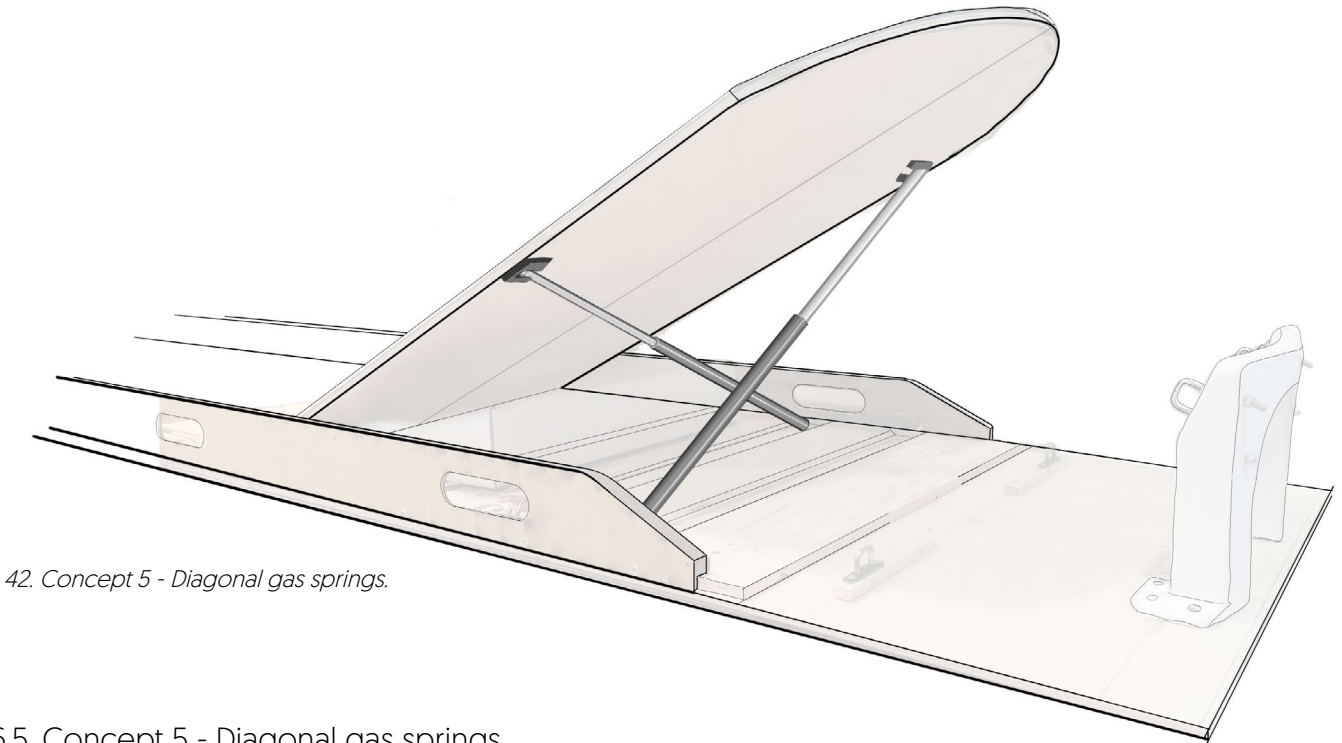

Figure 42. Concept 5 - Diagonal gas springs.

4.6.5. Concept 5 - Diagonal gas springs

This concept utilizes the recesses in the stretcher bottom to create a flatter mechanism. Exactly how flat will depend on the diameter of the gas spring. The lifting mechanism consists of two gas springs that are fastened diagonally from the stretcher bottom to the outer edges of the backrest. Doing this improves stability.

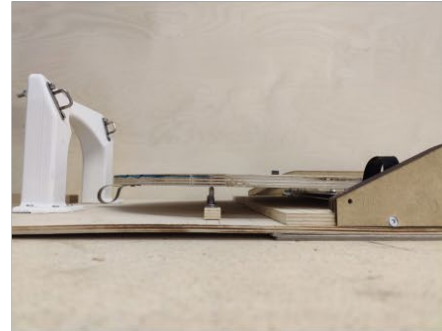

Figure 43-45. Prototype of the diagonal gas springs in the mockup.

[Video demonstration - perspective view](#)

[Video demonstration - side view](#)

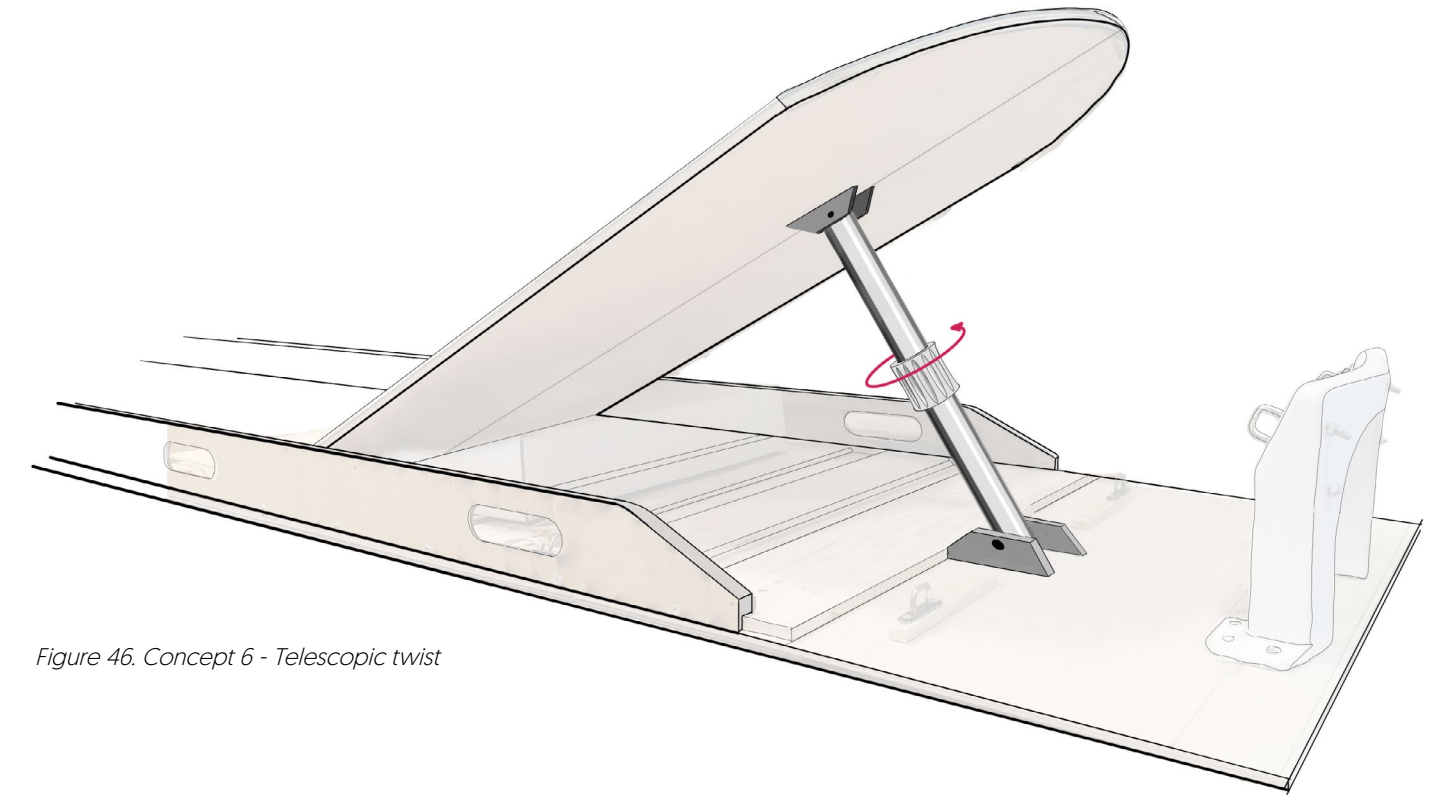
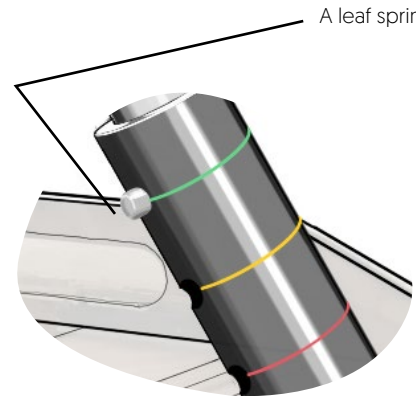

Figure 46. Concept 6 - Telescopic twist

4.6.6. Concept 6 - Telescopic twist

This concept consists of a telescopic profile with a locking mechanism similar to a ski mountaineering pole. The angle of the backrest is adjusted by twisting the mechanism. This however creates complications when the backrest is laid flat because the handle will be out of reach. The concept therefore needs another way to lock the profiles.

Due to this challenge, no prototypes were made of this concept.



A leaf spring keeps the lock in place.

Color coded holes for faster recognition by the operators.

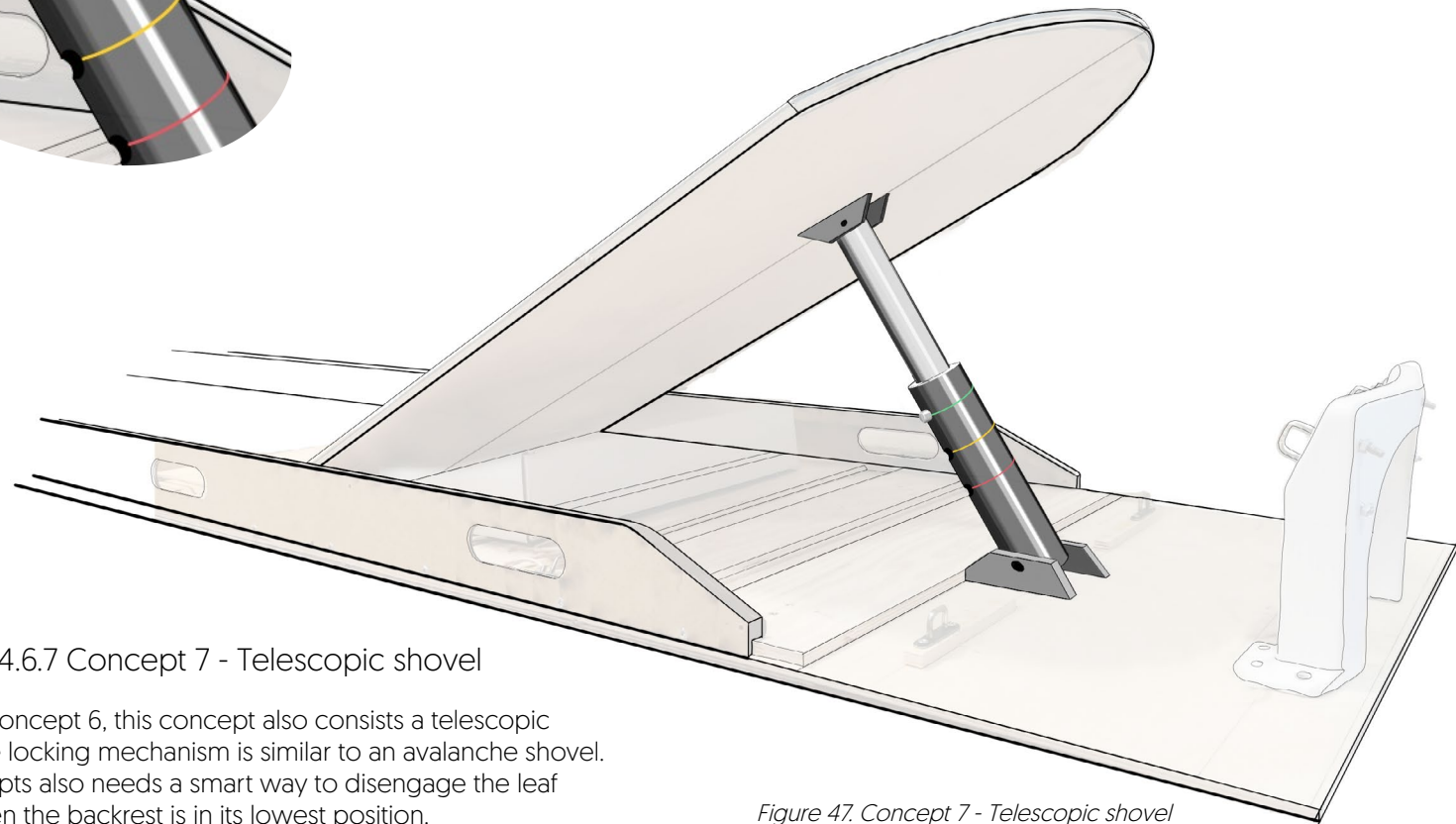

4.6.7 Concept 7 - Telescopic shovel

Similar to concept 6, this concept also consists a telescopic profile. The locking mechanism is similar to an avalanche shovel. This concepts also needs a smart way to disengage the leaf spring when the backrest is in its lowest position.

Figure 47. Concept 7 - Telescopic shovel

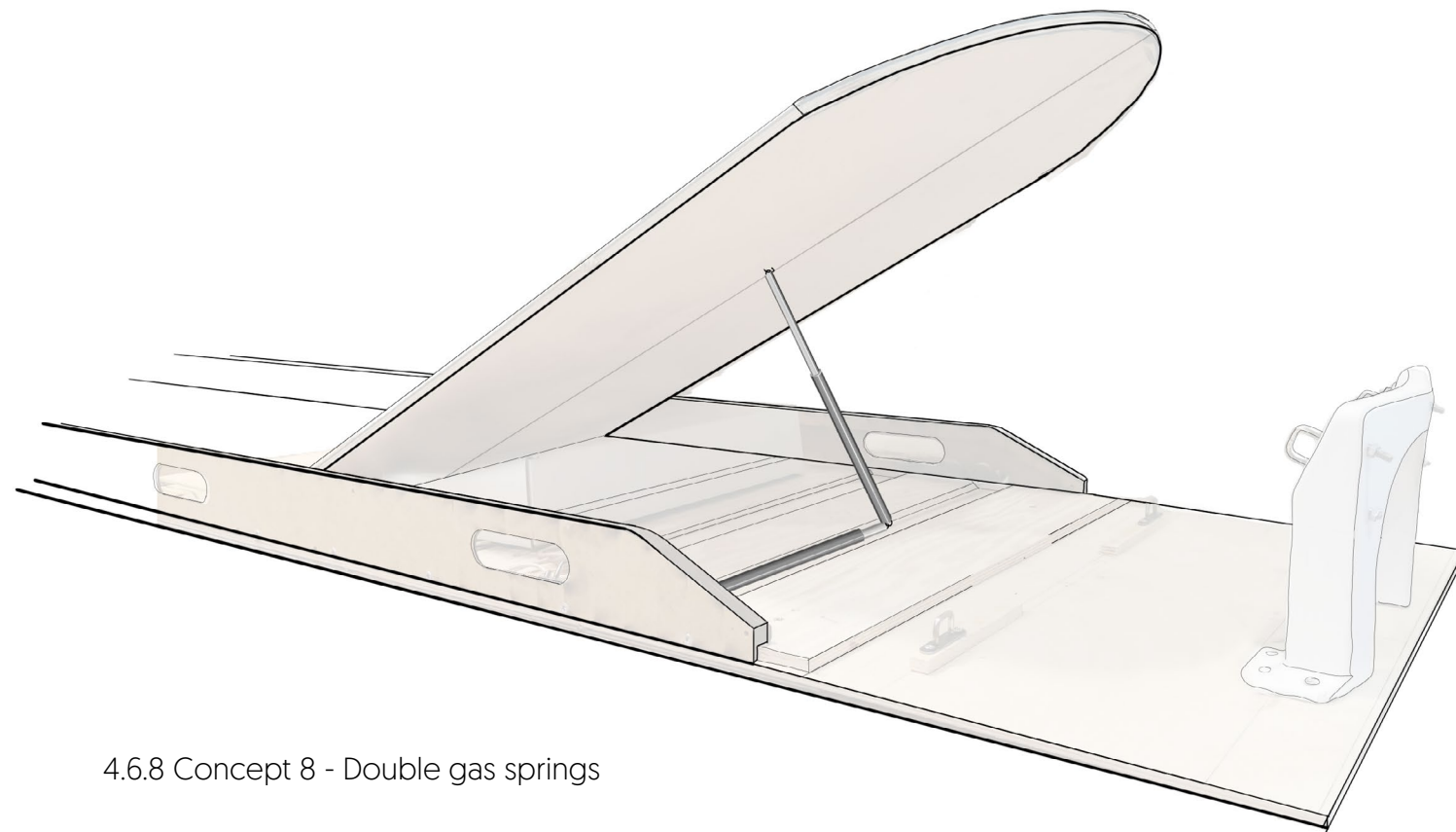

4.6.8 Concept 8 - Double gas springs

Concept 8 was developed in an attempt to create a mechanism that is located in the middle of the stretcher and is perpendicular to the backrest when the backrest is maximally elevated. This was achieved by having two gas springs connected together. One of them would lay flat in one of the recesses, while the other would be fastened perpendicular to the backrest.

Figure 48. Concept 8 - Double gas springs

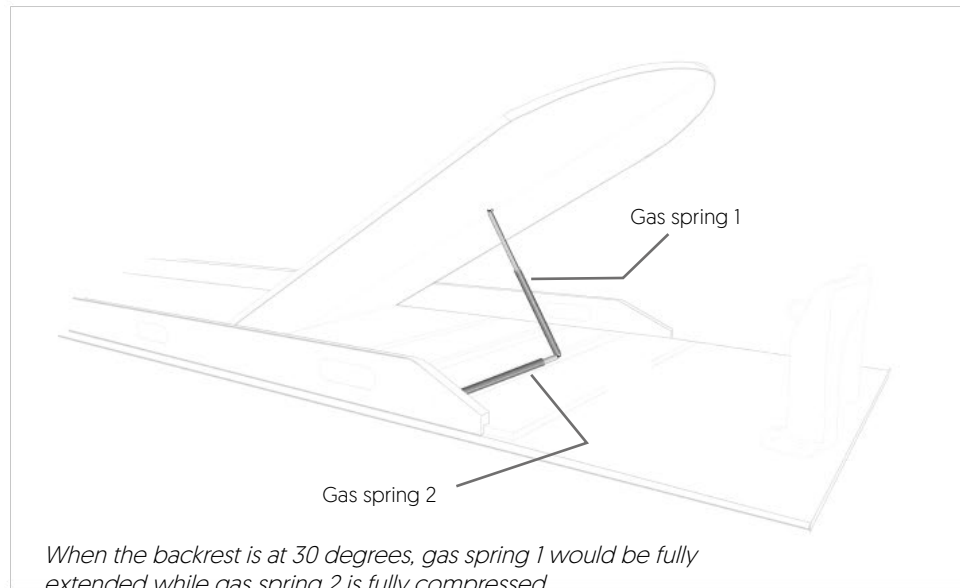
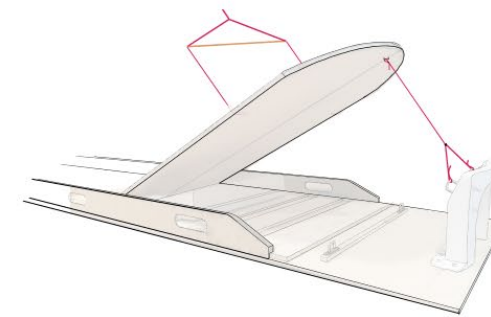
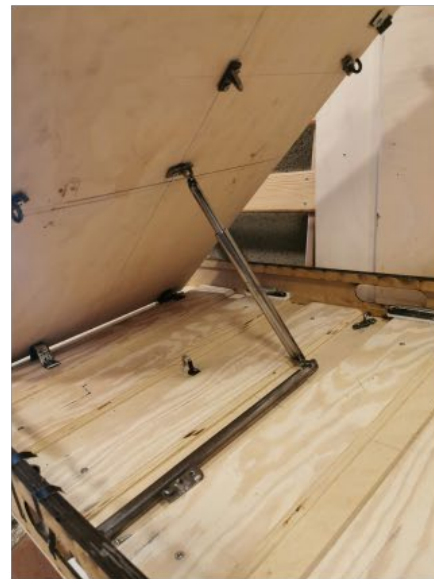
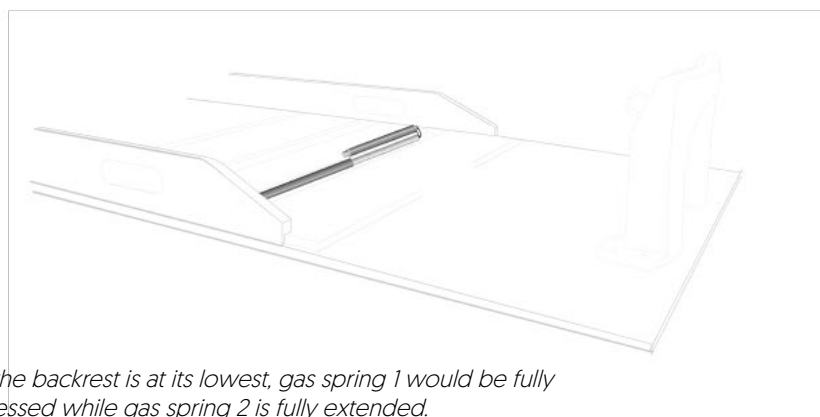
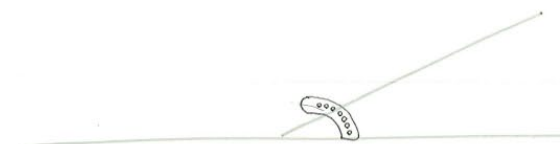

Figure 49. Concept 8 - Double gas springs



Pulley system from the helicopter roof.
 Why it didn't make the cut:
 Can't fixate anything in the roof
 Wouldn't work when it's not in the helicopter



Backrest angle adjustment inspired by workout equipment
 Why it didn't make the cut:
 Having the support for the backrest close to the hinge creates a bad kraftbilde, and also allows for more bending and movement in the backrest.
 To prevent this the mechanism could be bigger and be located further out on the backrest. However this would restrict the anaesthetists access to the patient when the backrest isn't elevated.

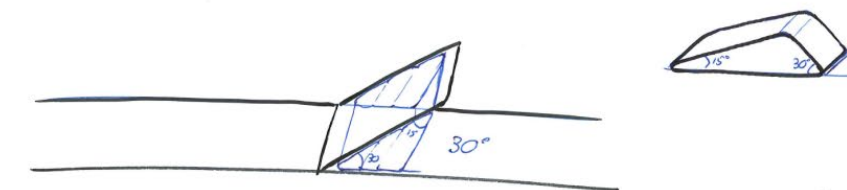

Pulley system from the helicopter roof.
 Why it didn't make the cut:
 Can't fixate anything in the roof
 Wouldn't work when it's not in the helicopter

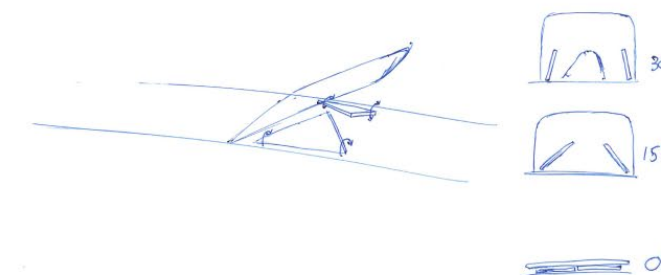

Angled flaps hinged at the stretcher floor. Recesses in the backrest keeps the flaps in place. One recess for 30° and one for 15°.
 Why it didn't make the cut:
 Operator has to manually adjust the two flaps.
 Flaps could easily fall out of its tracks.
 Mechanism does not prevent the backrest from bouncing back up.

To produce a satisfactory product, it is necessary to make it durable. It is necessary to perform calculations and analysis to prove this. Performing the correct calculations by hand provides context to the analysis to come as well as giving an indication early in the process. This is done to determine the forces being applied to the system as well as some of the stresses present in the system. A major criterion in the concept selection was the resultant forces in the system. When the forces increase, the stresses also increase. To battle the high stresses, the cross section or geometry needs to change. It is therefore ideal to reduce the resultant forces and momentums by selecting a geometry that transfers the forces in an ideal way.

Two of the leading criteria for this development is strong and lightweight. Combining the two criteria sets high demands to both geometry and materials. It is possible to achieve stiffness and strength through two methods. One is by the mechanical properties of the material, and the other is by altering the geometry of the part. By selecting a weaker material with a lower density, it is possible to take advantage of the geometry to improve strength, while simultaneously keeping the same, or even lowering the total weight of the component. As seen in the example formula for a beam with fixed support in one end and a load at the other, the stiffness of the material has an equal contribution as the second moment of area. Altering the geometry as shown below will result in a I that is roughly 2400 times larger than the original. While maintaining the same total area of cross section and therefore also the mass. [Johannessen, 2002]

$$\delta_{max} = \frac{l^3}{3EI}$$

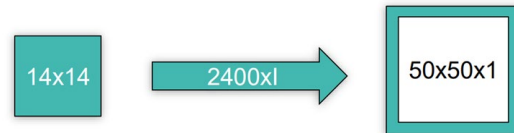

Combining the altered cross section with a change in material from steel to aluminum will increase the stiffness 840 times while reducing the weight by almost two thirds [all values and formulas presented found in [Johannessen, 2002]

4.7 Preliminary calculations

To perform calculations of the resultant forces it is important to determine the forces applied to the system. A quick test was performed by Borgen & Strand to determine the weight at the edge of the stretcher. This was observed to be 14kg with an 80kg person lying on the stretcher in roughly 30 degrees on a 900mm backrest.

This data serves as a basis for the rest of the calculations done in the thesis. To stay conservative the weight was rounded up to 15. Determining the moment arms of the system proved to be a challenge since no human is made equal. Therefore, it was necessary to simplify the system. The weight was set to work perpendicular to the ground plane on the plane of the backrest.

Finding the centre of mass of one part of a human body is no simple feat. The total centre of mass will move as the body moves as shown in figure 50. This will also vary greatly based in the patient's height and body composition. The centre of mass was set to the geometrical centre of a person sitting in a 90-degree angle on the floor. The person in question is 192 and the geometrical centre was 500mm off the floor. This is a conservative value for two reasons. The person is above average height in Norway. And the centre of mass of the torso is slightly below the geometrical centre of the torso [Clauser, McConville, & Young, 1969].

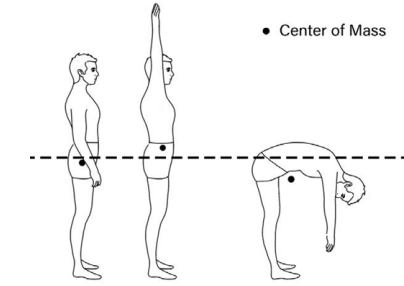

Figure 50: How the centre of mass moves relative to the geometrical centreline of a human. [Oleano, 2023]

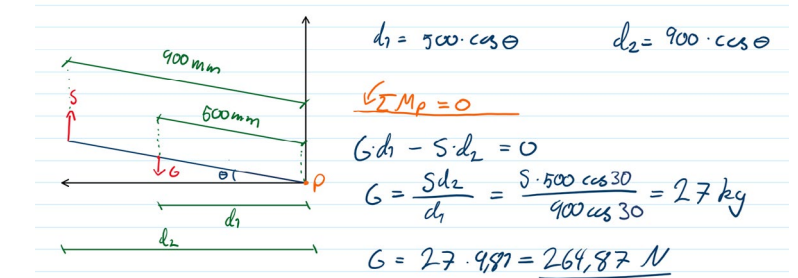

Figure 51. Calculations determining the force of gravity applied in the system.

The calculations result in a force applied to the system of 265N. Please note that the force would be offset in from the plane and the force would be distributed between two resultant forces. One perpendicular to the plane and one parallel. The force and location of the force will be used for the following calculations.

Hand calculations were performed to evaluate how the forces were transferred in the system and the resultant forces in the mechanism themselves. By evaluating the systems like simple beam structures, it is possible to obtain a rough estimate of the resultant forces present. These simplifications aimed to make an idealized version of the concepts in a two-dimensional plane and linear point forces. Some examples of these simplified systems can be seen in figurexxx

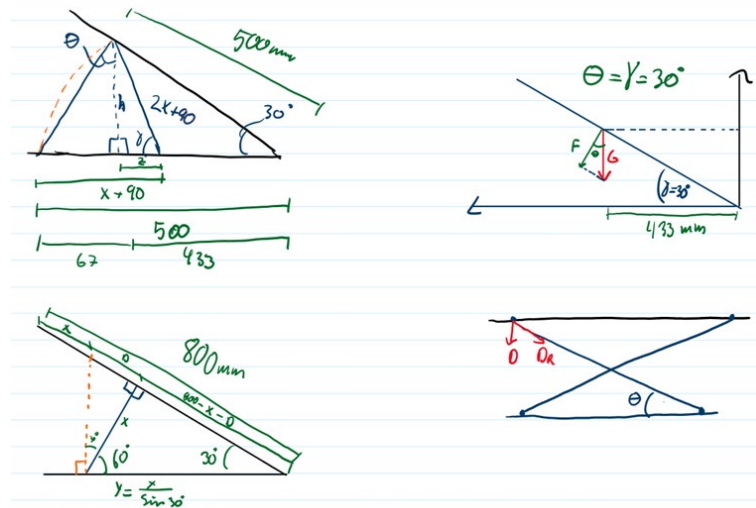

Figure 52: Examples of simplified systems to evaluate resultant forces in the concepts.

These simple calculations served as a means to evaluate how the systems transferred force as well as the resultant reaction forces. The results of the calculations can be seen in the tablexxx and the complete calculations can be seen in vedleggxxx.

Concept 1	172 N
Concept 2	N/A
Concept 3	274 N
Concept 4	292 N and 183 N
Concept 5	314 N and 205 N
Concept 6	274 N
Concept 7	274 N
Concept 8	N/A

Table 4. Calculated forces in the concepts.

Note that concept 2 and 8 has the statement not applicable. This is due to them being eliminated before the calculations were done. Also note that concept 5 has two values. This is because there are two gas springs with different locations in the system. One closer to the hinge than the other. Lastly concept 4 also has two values. The larger is if the spring is in the mass center, and the lower is for a spring located as far away from the hinge as possible.

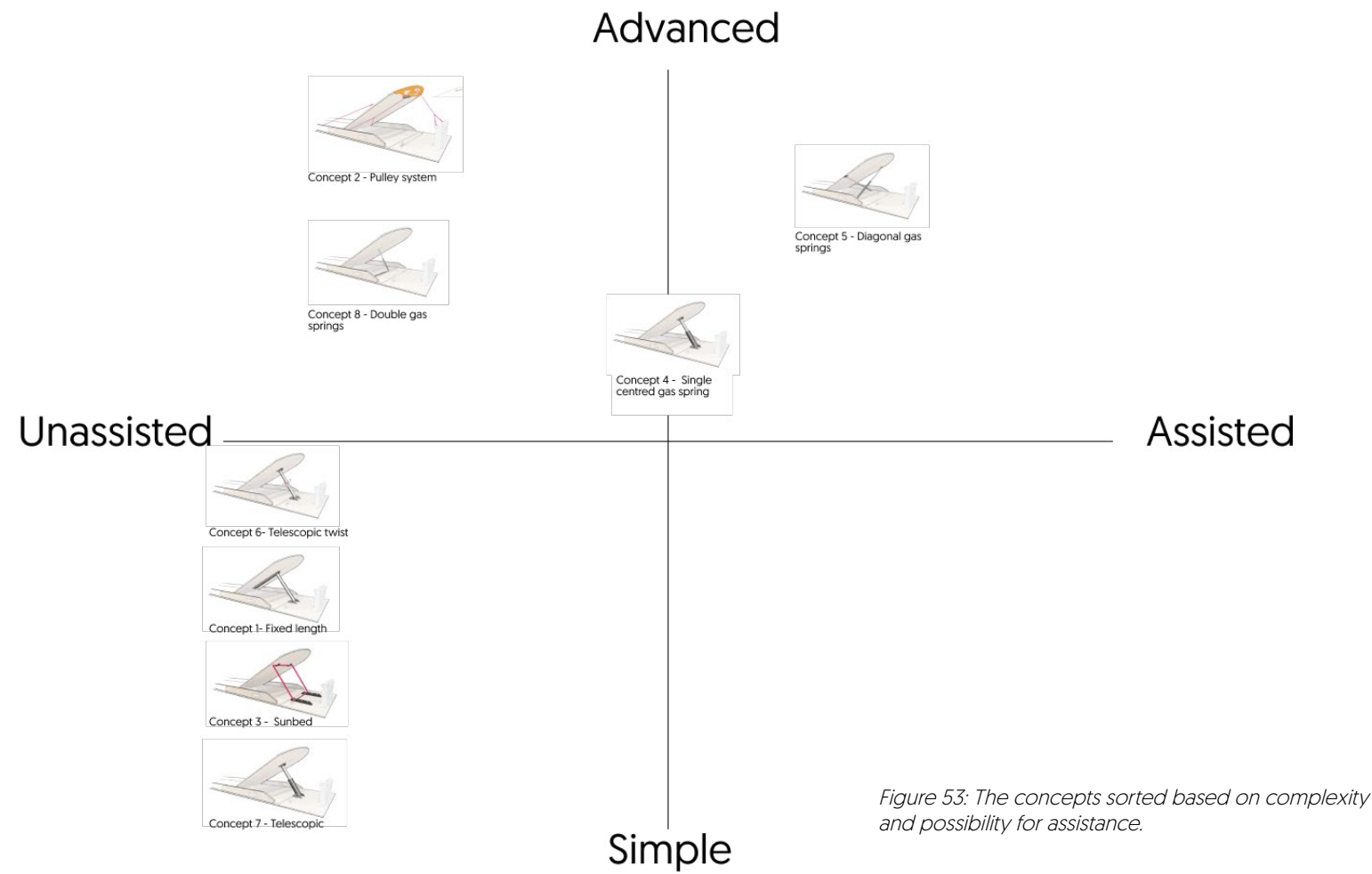

Figure 53: The concepts sorted based on complexity and possibility for assistance.

To get a better overview over the concepts, they were sorted based on simplicity and degree of assistance. The ideal solution is both simple and provides assistance without adding too much weight.

Concept 1, 3, 6 and 7 are completely unassisted and are all relatively simple and well known mechanisms. Concept 2 and

8 could be assisted to some extent, but are also much more complicated. Through working with concept 2 it was clear that it wouldn't work the way it was set up. Concept 4 is familiar and can both be assisted and unassisted. Concept 5 is more complex, but still functional and realistic as discovered through prototyping.

4.7.1 8 concepts down to 4

Due to limited time and long distances a "user test" was arranged digitally to help narrow down the concepts. Both rescuers, anaesthetists and industrial designers were invited. The concepts were presented and demonstrated before they were evaluated in a plenary session based on the requirement specification with a focus on easy operation. The highlighted concepts are the ones considered to have most potential for a final solution.

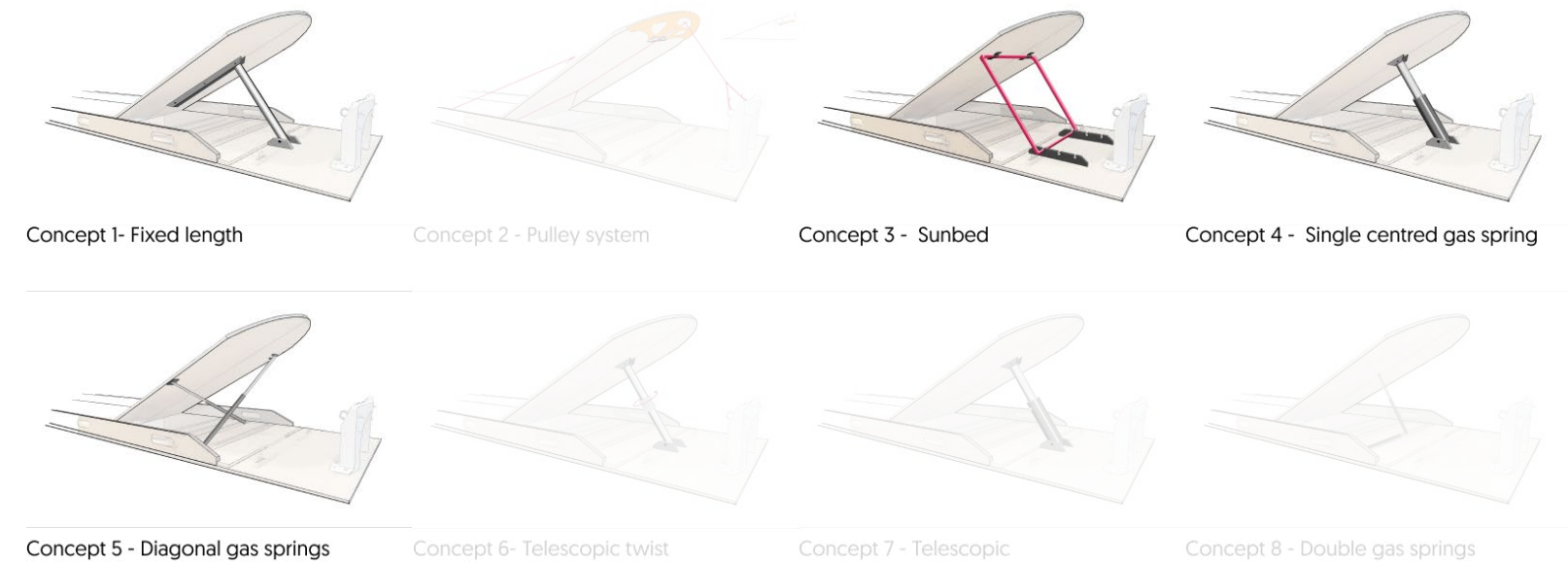

Figure 54: The four most promising concepts

4.8 Detailing the concepts

There are three different aspects of each concept. How the mechanism works and locks in different angles. How the mechanism is fastened to the stretcher. How the mechanism is operated.

Each concept has a varying level of complexity. To save time and resources, each concept is only developed to a degree where the functionality is proven and it can be compared to the other concepts.

There are two criteria that limits the variation of aspect 2. The first is the criteria saying that any new installation has to be easily removed from the stretcher without tools. The other is that no structural changes can be made to the stretcher. These criteria makes the fastening of all the concepts fairly similar. This meant that aspect 2 wasn't going to be the decisive aspect of the concepts.

This further meant that time would be best spent looking at how the concepts would solve aspect 1 and 3.



Concept 1- Fixed length



Concept 3 - Sunbed

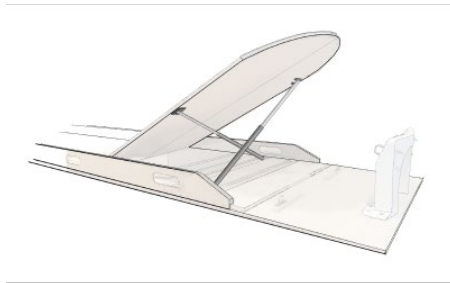

Concept 5 - Diagonal gas springs



Concept 4 - Single centred gas spring

Figure 55. Detailing the 4 concepts..



Figure 56. This was the preferred position when focusing on ease of lifting while maintaining good overview and access to the patient while not being in the helicopter.



Figure 57. From the anaesthetist position in the helicopter. Facing forwards. Using one arm only.

To kickstart the detailing phase a simulation of elevating the backrest was performed.

Through the interviews paramedics have said that an assisted mechanism is beneficial, but not a must. To get a feel for the weight ourselves, a test was done by simulating the position an anaesthetist has in the helicopter. Our own impression matches the paramedics statement.

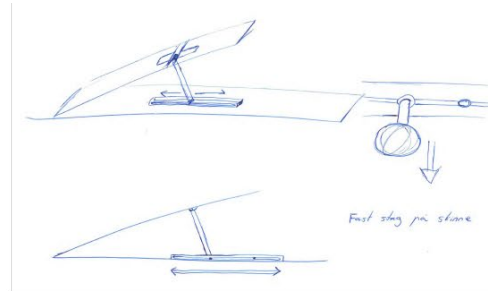
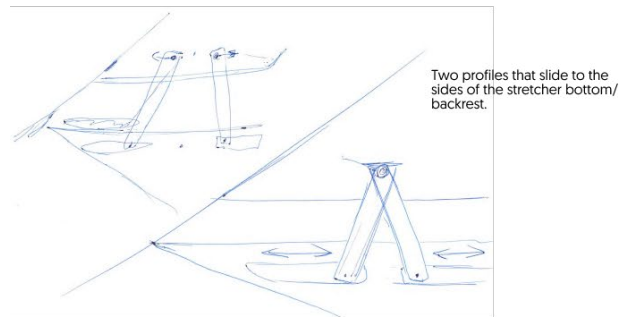

Figure 58-60. From anaesthetist position in the helicopter. Facing backwards. Using one arm only.



4.8.1 Detailing concept 1

The challenge for this concept is to develop a secure mechanism that locks both up and down while also being easy to operate. The detailing started by looking at different ways a fixed length profile could achieve both 0 and 30 degrees.



Mounting a profile to a rail. Adjustment similar to workout equipment.

Having a leaf spring push into holes in a bracket in the backrest. Similar to an telescopic shovel.

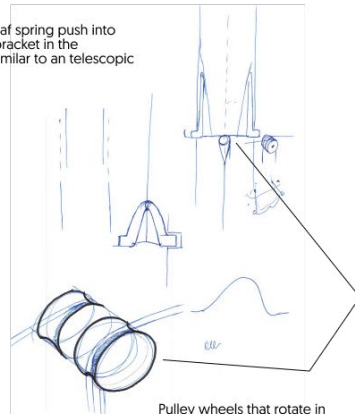

Handle on the side of the stretcher. Pulling it releases the slider and lets it slide freely based on the angle of the backrest.

Springs that keeps the system under tension

Fixed length profile

Slider that can slide up and down in tracks

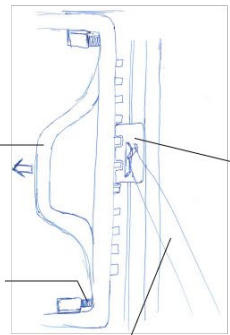

Pulley wheels that rotate in opposite directions.

Teeth on both sides of the slider. Pulling the handle on top of the backrest pulls the teeth on the slider back and allows it to move.

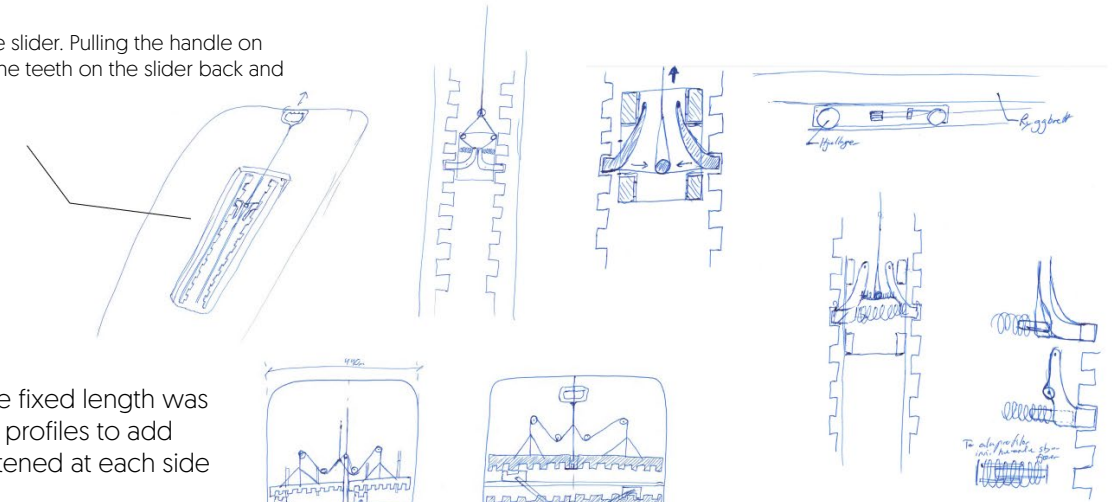

What started as a concept with one fixed length was changed into having two diagonal profiles to add support. The profiles would be fastened at each side of the stretcher floor.

Eventually the sketches were turned into a 3D-model and laser cut to get a better feel for the concept. Pulley wheels were 3D-printed, and metal parts were cut to support the mechanism.

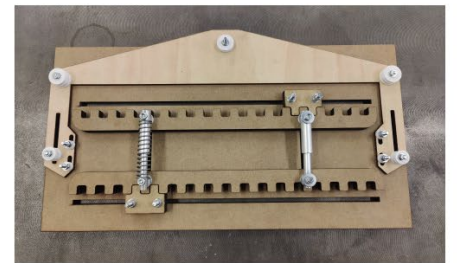
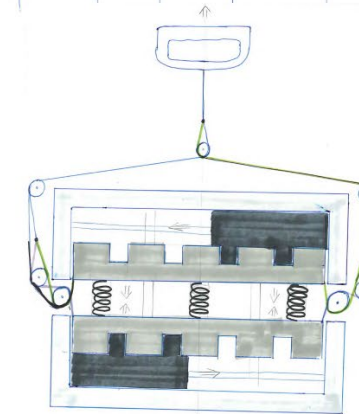
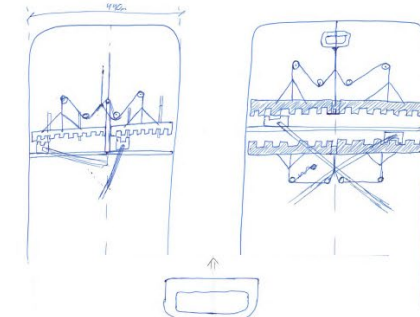
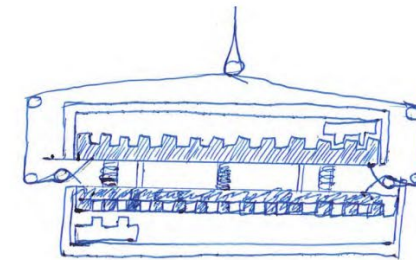

How the concept works

Pulling the handle compresses the spring and lets the sliders slide freely based on the angle of the backrest. Lowering the backrest pushes the sliders outwards, while elevating the backrest pulls the sliders inwards. When the backrest is at its lowest, the sliders will be in each corner. The upper one will be in the left corner while the lower one is in the right corner. When the backrest is elevated to 30 degrees, the sliders will be close to the middle, but not completely centred. This is so the slider always has a direction it wants to slide when put under pressure. If it had been completely centred it could go both ways. An easy way to fix this is to limit the slider's range of motion by only having teeth on certain parts of the "mouthguard". This would have been done for a second iteration, but the model was sufficient to prove the concept at this point.

Due to a very limited selection of available compression springs at the workshop, there was only found one spring with an approximately correct length and k-value*. The concept is supposed to have springs on each side. Having a spring on only one side made it hard to move the sliders smoothly. The idea of the concept was however still proven.

* The k-value is the amount of force it takes to compress the length of a spring a given amount.

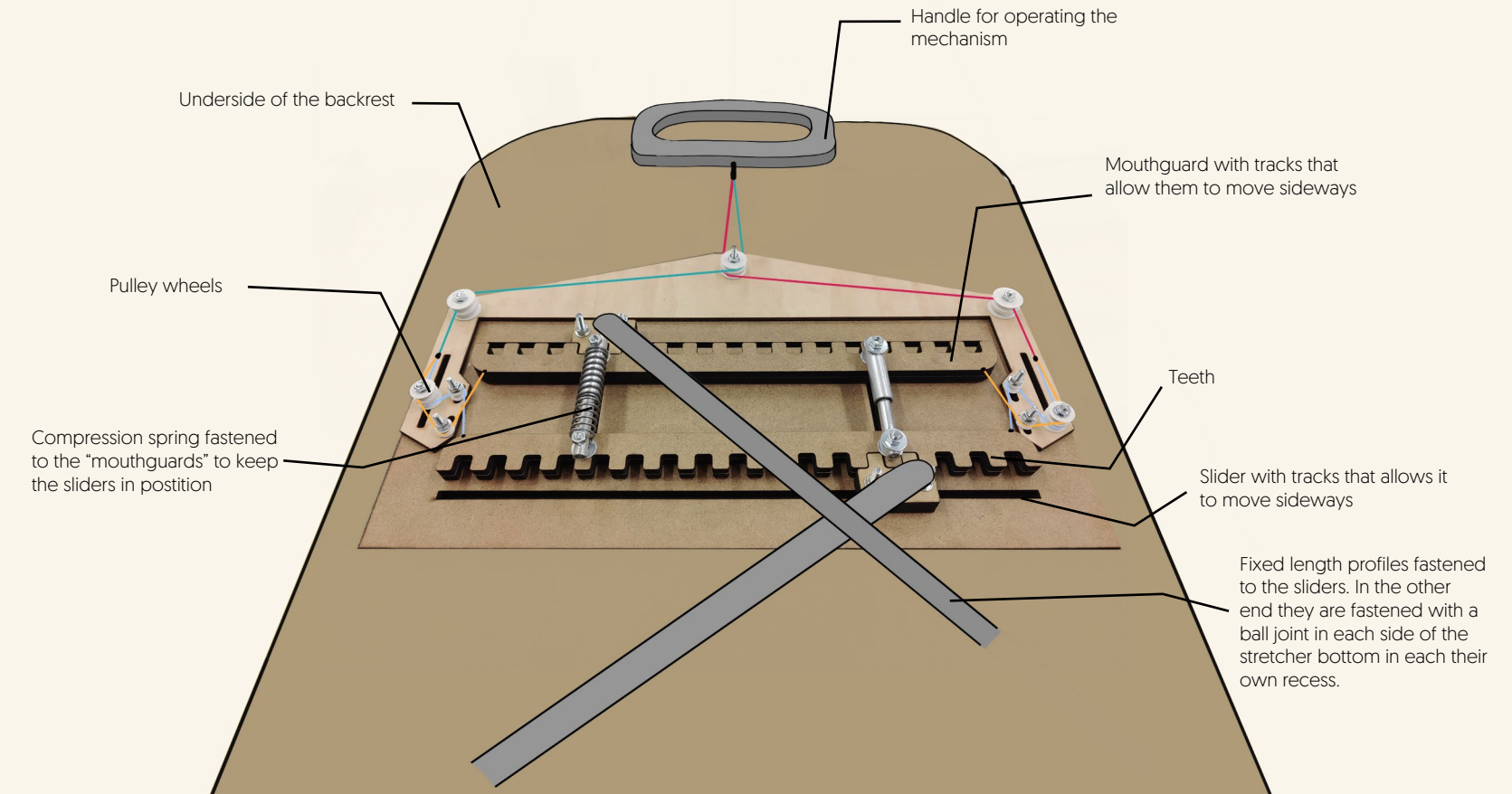
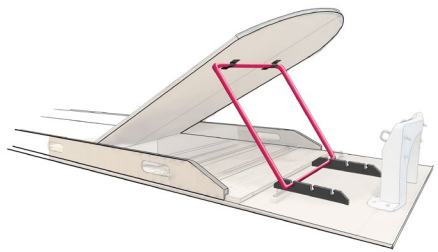

Figure 61. Prototype of locking mechanism for concept 1.



4.8.2 Detailing concept 3 - Sunbed

This concept's challenges was to develop a mechanism that would prevent the backrest from going either up or down, and also make operating the mechanism easy. The initial idea was to have the mechanism pivot around backrest, but this was changed after talking with paramedics to have it hinged at the stretcher bottom to make operating the locking mechanism easier.

The concept's advantages is that it is sturdy, stable and can handle a lot of force. One of the downsides is that is is a two hand operation. One hand lifts the backrest while the other adjusts the mechanism. Another is that it builds pretty large out from the backrest. This results in a minimum angle of around 7 degrees instead of 0.

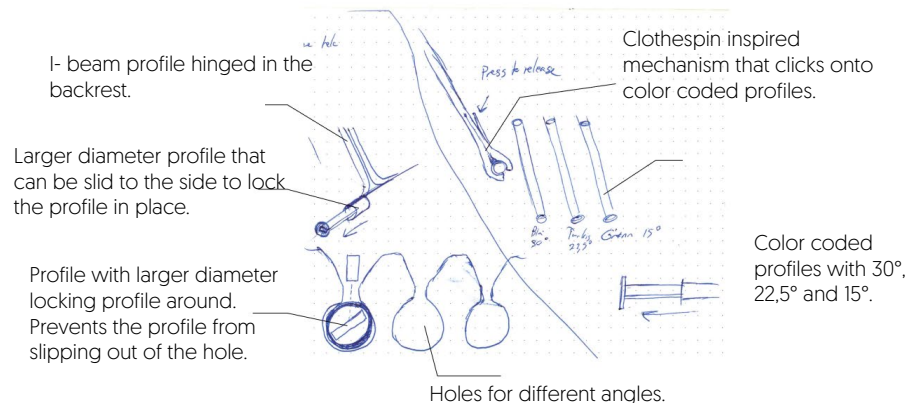
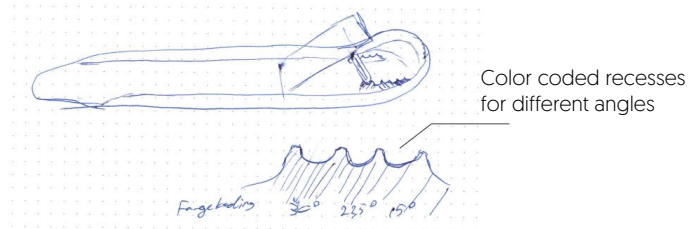

Solutions for a locking mechanism were sketched out, 3D-modeled and laser cut. The chosen concept has two unique profiles that lock when they are overlapped. The first profile has immersions that correspond to the locations for the 0°, 15° and 30° angles. A handle is connected to the second profile. When the handle is pulled, the second profile will slide and the immersions will be accessible. When unactivated, hooks on the second profile will lock the mechanism in place.

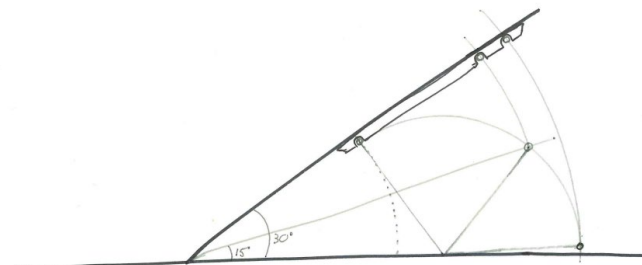
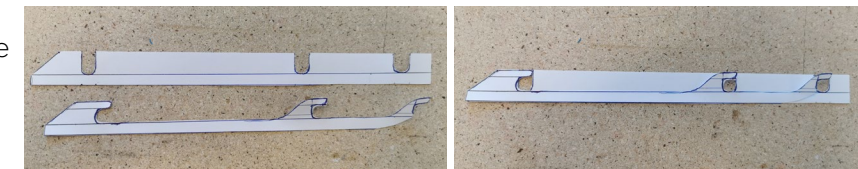

Figure 62. Illustration of why the immersions aren't equally spread.

One of the challenges this concept faces is that immersions for the 0° and the 15° angles are very close. This leaves little room for the profile that locks the tube in place. The concept went through sketches on paper and paper mockups before it was 3D-modeled and laser cut.

Improvements for the first iteration
 - Angled immersions to make the tube slide in and out of the immersions more smoothly. This drastically changed the room for the 0° hook.

Improvements for the second iteration
 - Smarter hook profile that locks tighter.
 - The sliding profile got attachment points to connect it to an operating handle.

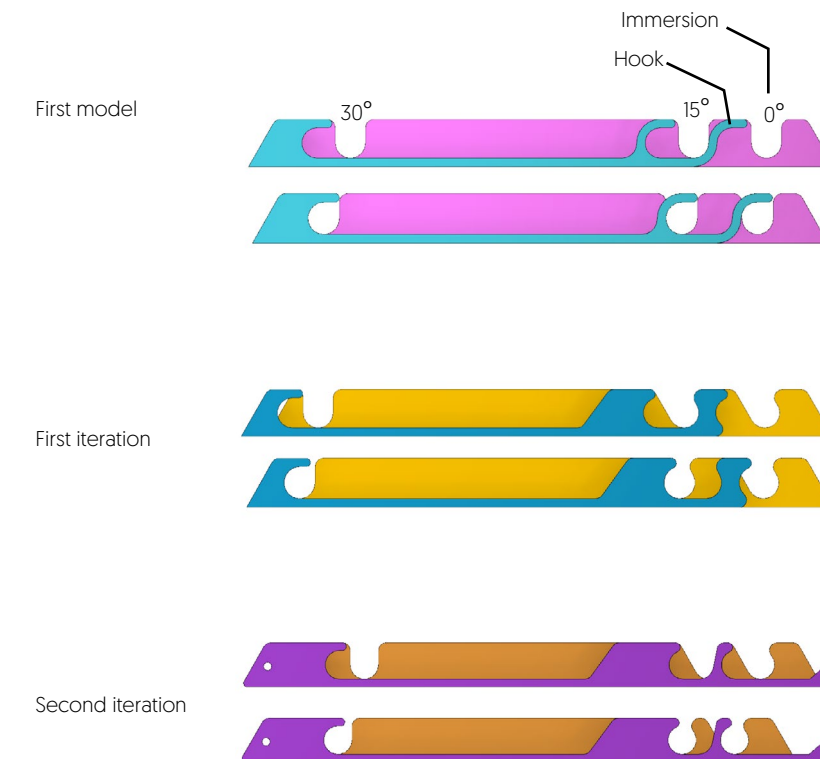

Figure 63. Iterations of the locking mechanism for concept 3.



Figure 64-66. First prototype to test the functionality of the lock



Open



Locked

Second prototype

An iteration was done for a more sturdy prototype. The two layers were iterated and got angled recesses to make the profile slide more smoothly in and out of the recess.



Figure 67. Mechanism open.



Figure 68. Mechanism closed.

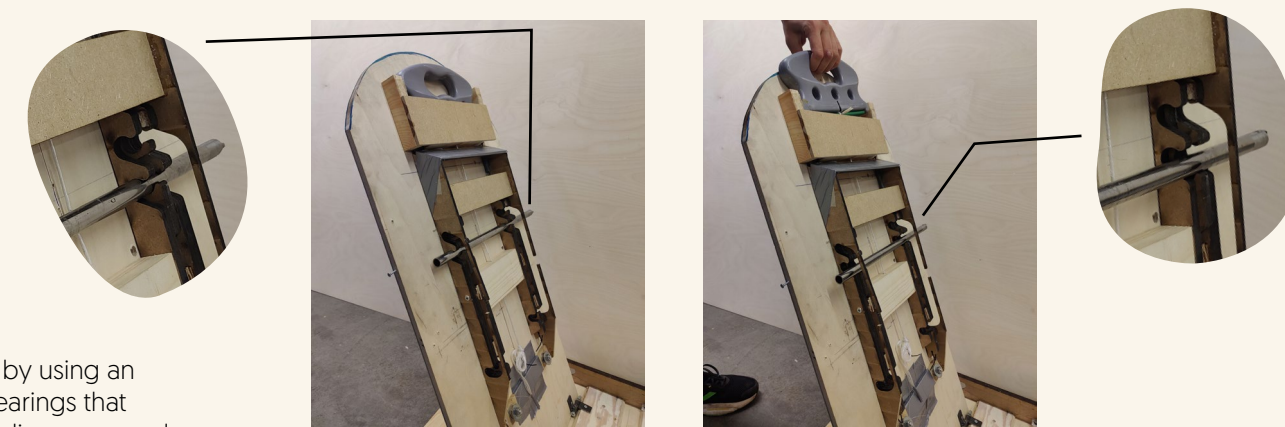

Pulley wheels were made by using an angle grinder on wheel bearings that were thrown away. Fishing line was used to connect the handle to the mechanism. As there was no more line on the fishing harp, the harp handle was used as a handle for the prototype.

[Video demonstration of the concept](#)

Figure 69. Testing the iterated mechanism in the mockup.





4.8.3 Detailing concept 4 - Single centred gas spring

For this concept it was essential to find out what kind of gas spring that was needed, and how much force it would have to withstand.

As the Aerolite Cirrus stretcher uses a similar concept, it was clear that the operation of the mechanism could be designed in a similar matter. It was therefore not in focus for the detailing of this concept.

There are three different types of gas springs.

A pressure gas spring will always be extended if it is not mechanically compressed. This gas spring is used e.g., to keep a car's tailgate open.

A tension gas spring will always be compressed if it is not mechanically extended. This type is used e.g., to keep a door shut.

A blockable gas spring is a pressure gas spring which can lock at any given point within its range. This type is often used in office chairs.

GIS BORT



Sliten kontorstol gis bort

Figure 70. Using an old office chair to find a blockable gas spring.



Figure 71. Gas spring installed in the mockup stretcher. Testing maximum angle.

It was desired to get hold of a blockable gas spring to test the concept further. Most adjustable office chairs use this type of gas spring. An old chair was given away at Finn.no due to having non functional wheels. This gave the opportunity to build a functional model at low cost and environmental footprint.

The chair was dismantled and adapted to a new area of use as a gas spring for the backrest.

With a gas spring of this size, the mechanism builds quite large. This further causes the backrest to be in an angle instead of flat.



Figure 72. Gas spring installed in the mockup stretcher. Testing minimum angle.

[Video demonstration of the concept](#)



4.8.4 Detailing concept 5 - Diagonal gas springs

Operation of this concept would be similar to concept 4. The difference is that this concept would need to have wires going to each gas spring to be able to activate them simultaneously.

The functionality of having two gas springs in two different recesses was also proven to work well through the first prototype of this concept.

Further detailing was therefore not needed for this concept.

[Video demonstration side view](#)

[Video demonstration perspective view](#)

4.8.5 Weight estimates of the concepts

As the fixture aims to be lightweight, the total weight of each concept is of high importance. Two of the concepts in question had a rough cad already which could be used to estimate the total weight. The four concepts bore high resemblance in their geometry from a fastening perspective. To reduce work, it was decided that all concepts had an equal weight for their fastening mechanisms. The parts were assigned an appropriate material in CAD software. The geometry was then examined to give an indication of how much it would be possible to reduce the weight by altering the geometry. The parts that had yet to be made got a generous overestimate to try and make the comparisons fair. The results were added up as shown in the table below.

Concept 3 - Sunbed	3220 g
Concept 4 - Gas spring	1158 g
Concept 5 - Diagonal gas springs	1916 g
Concept 1 - Fixed length	3136 g

Table 5. Estimated weights of the concepts.

4.8.6 Concept evaluation

Normally, at least from a designers point of view, the concepts would be user tested in order to help land on a final concept. However in this case there was nothing for the users to test. The operating mechanism could be made equal for all concepts. The smoothness of operation can vary a bit. The gas spring can lock at any given point while the others have to get the slider in a notch to be locked. It is therefore likely to believe that the users would prefer a concept with gas spring.

The joker here is the weight. If the gas spring concepts are significantly heavier, this might make one of the other concepts better.

This meant that weight estimations would be the critical factor for the concept evaluation.

#	Needs	Weighting	Concept 1	Weighted result	Concept 3	Weighted result	Concept 4	Weighted result	Concept 5	Weighted result	Comments
1	Low weight	5	2	10	1	5	4	20	3	15	calculated weight
2	Easily manoeuvrable size	4	3	12	1	4	2	8	4	16	5 into silts, 1 is high on backboard, 3 is billig
3	Easy to install and remove	4	1	4	1	4	1	4	1	4	All the same
4	Easy to operate when installed	5	2	10	1	5	3	15	3	15	Two-handed. Unassisted. Equal.
5	Can achieve at least 30°	5	1	5	1	5	1	5	1	5	All the same
6	Can be used in multiple stretchers	1	1	1	1	1	1	1	1	1	All the same
7	Can handle high stress and vibrations	5	4	20	3	15	2	10	1	5	Concept 5 has to withstand the highest force. Looking at the force calculations.
8	Can fit all patients regardless of size	4	1	4	1	4	1	4	1	4	The same.
9	Can be used in different temperatures	5	2	10	2	10	1	5	1	5	gas spring temperature range -20 - +50
10	Can lock at a given angle	2	2	4	1	2	3	6	3	6	sunbed has 3 clicks, fixed length more and gas springs infinite
11	Long lifespan	3	2	6	2	6	1	3	1	3	limited amount of lifespan
12	Assisted lifting	2	1	2	1	2	4	8	4	8	gassprings assists lifting
13	Mechanism does not move in rough terrain	5	3	15	3	15	2	10	2	10	some give in gassprings
14	Ergonomics	3	1	3	1	3	3	9	3	9	Sunbed and fixed length has a given distance they have to be moved. Gas springs has a much smaller distance. more flexibility for ergonomic design
15	Certification for use	5	N/A	N/A	N/A	N/A	N/A	N/A	N/A	N/A	Not relevant
16	Can be folded with the stretcher	1	N/A	N/A	N/A	N/A	N/A	N/A	N/A	N/A	Not relevant
17	Legal fastening of stretcher to helicopter	1	N/A	N/A	N/A	N/A	N/A	N/A	N/A	N/A	Out of scope
18	Better straps to secure patient	1	N/A	N/A	N/A	N/A	N/A	N/A	N/A	N/A	Out of scope
19	Smooth operating. (No sudden movements)	1	2	2	1	1	3	3	3	3	
	SUM			108		82		111		109	

Table 6. Concept evaluation using weighted needs and concept performance in the respective needs. .

The needs are weighed based on their importance for the product.

The concepts are compared to each other and given a score of 1-4. The concept performing best at the given need gets a 4, while the lowest performing concept receives a 1. If there are two concepts that performs equally they get the same score. The weighted results are calculated by multiplying the weighting by the score for each concept. The SUM is calculated by adding the weighted result for each need.



Figure 73. The final concept for the elevation mechanism.

4.8.7 Detailing the final concept

An adult male in Norway has an average height of xxx cm, and a navel height of xxx cm. The centre of mass of an human body is about 2,5 cm below the navel. The average thickness of a human body is about 25 cm. This means that the force from the human body will hit the backrest approximately 500 mm from the hinge.

The thought for this concept was initially to have the gas spring fastened perpendicular to the backrest when the backrest is at 30°. This is illustrated in "Version 1". A perpendicular gas spring is desirable because it will be facing directly towards the force from the patient and backrest, and therefore be strongest in that position. This however turned out not to be feasible as the gas spring can't be compressed to fit between point B and C.

As mentioned earlier, the appropriate gas spring for this project is a blockable gas spring. The total length can be described as $2x + y$, while the minimum length is $x + y$, as illustrated in figure xx.

Version 2 and 3 illustrated the closest to perpendicular the gas spring can be from each side of the perpendicular line.

Figure 74. Repeating the options for the positioning of the gas spring.

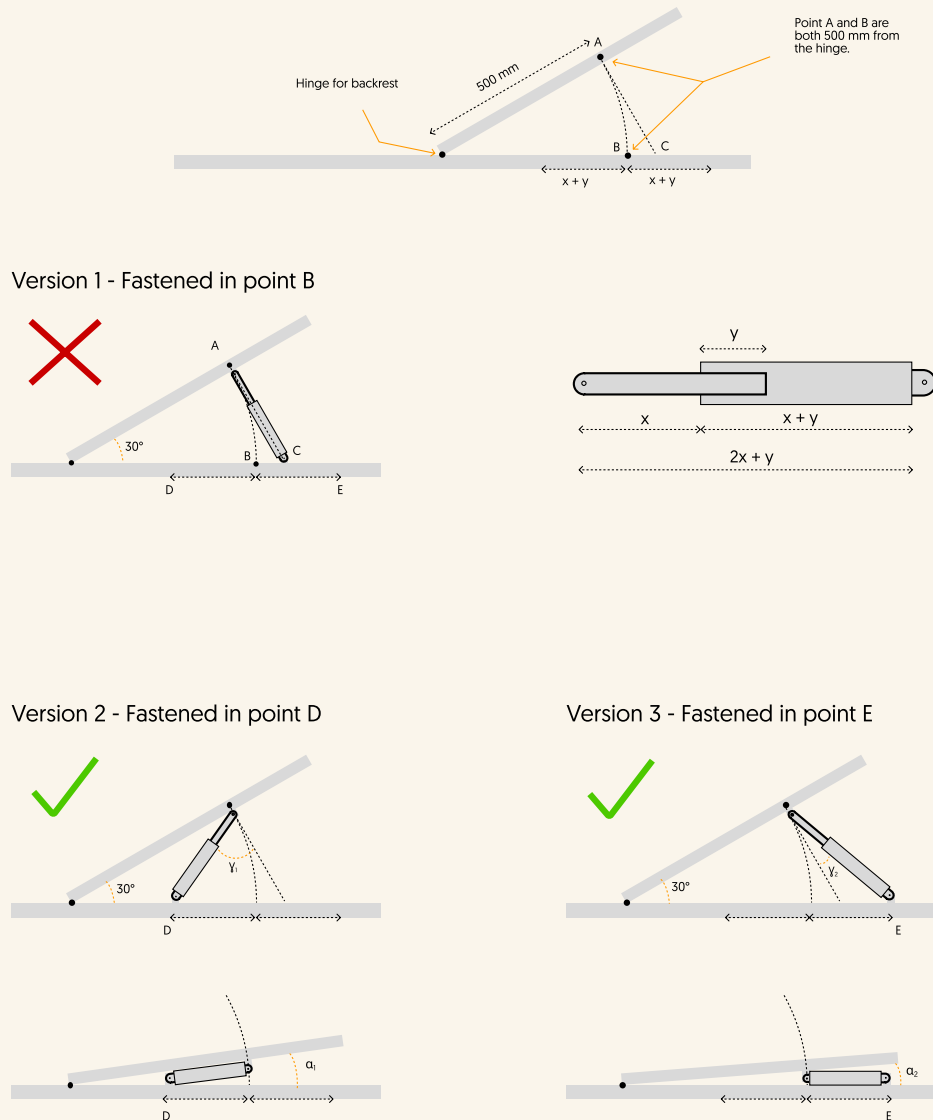

The positioning of point E is an optimization problem. Because of the better angle α , point E could be moved closer to the hinge while still having the same force as the gas spring in version 2. Moving the fastening point on the backrest away from the gravitational centre creates a momentum which can be unfortunate.

Version 3₂ still requires a longer bracket between the hinge and the fastening point than Version 2, which results in a heavier bracket. Without time and resources to test different pressures in the gas spring it was also a more safe bet to go for Version 2 and choose a gas spring with the same amount of pressures as the Aerolite Cirrus stretcher has.

Version 3₁ - Fastened in point E₁

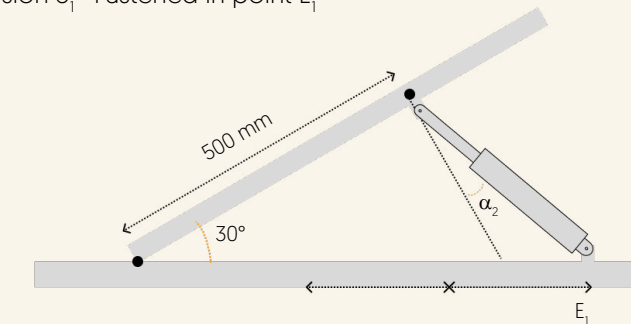

Version 3₂ - Fastened in point E₂

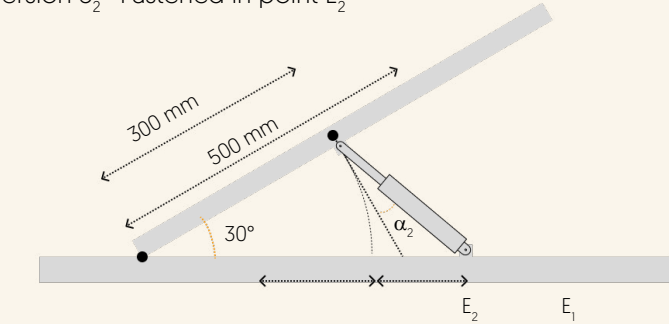

Figure 75. Repeating the options for the positioning of the gas spring.

4.9 Finding ideal angle and length of the gas spring

After finalizing the decision of a single gas spring lifting mechanism more calculations can now take place. The first calculation is an extension of the initial calculations of the system. Deciding the ideal angle of a gas spring. This angle is the highest angle the gas spring can achieve while still being able to lay down flat. The calculations are based on the information provided by Landgraff about one of their blockable gas springs. The length of the gas spring when extended is 90mm in addition to two times the stroke length. When contracted the gas spring has a total length of 90mm plus the stroke length. The method of determining the ideal angle can be seen in figurexxxx

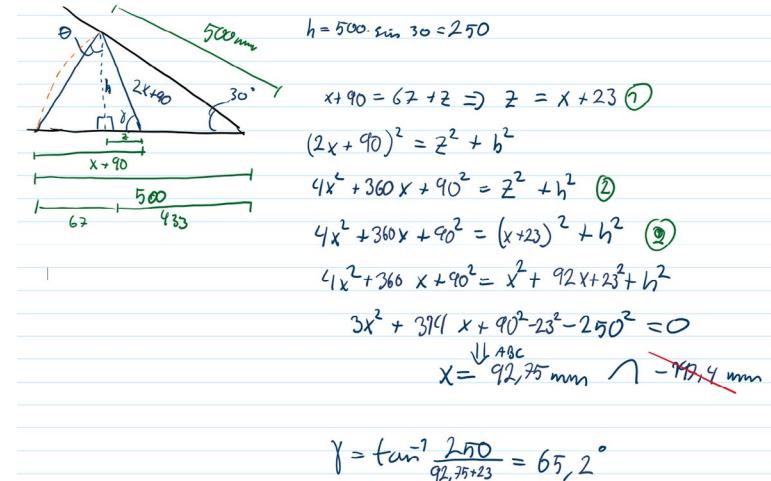

Figure 76. Calculations for finding the ideal angle.

Using this angle it is possible to determine the idea stroke length. This is an optimization problem between weight and strength. If the gas spring is far away from the spring, the force going trough it is lower. However, this also yields a larger piston witch will add unwanted weight to the fixture. From numbers given by Landgraff on a phonecall, the pistons can withstand five times their pushing force when locked. Meaning a 500N gas spring will be able to withstand at least 2500N before beginning unwanted compression.

The force of the gas spring is set to 450N as observed on aerolite cirrus stretcher. Please note that the geometry of this setup is unknown, and the exact forces present in their stretcher is not accounted for. This is a rough approximation and an idealization of an existing functional system with limited available data. The thesis is also lacking the time and resources to conduct an in depth study of the ideal force of a gas spring. Providing an ideal model of the force of the gas spring is outside the scope of this thesis but could potentially result in an improved final design.

The safety factor of the gas spring will be set to 7 based on interviews. In the insight phase it was uncovered that the 20G limit is based on a crash scenario as opposed to daily operation. In daily operation it is reported to be a maximum of 5G. To be certain that the components of this fixture will not buckle under this load it is dimensioned for a total load of 7G. This value is set as a minimum and most components should stay clear of this margin. However, no parts of the fixture should experience plastic deformation at a load lower than 5G.

The system in question is set up as follows;

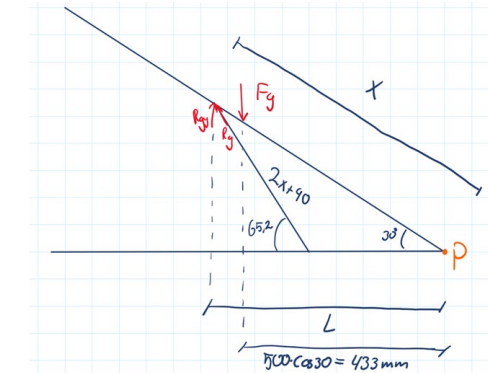

Figure 77. Calculations for finding the ideal stroke length of the gas spring.

The calculations begins by setting the momentum of the hinge [point P] equal to zero giving that:

$$R_{gy} * L = G * 433 \text{ mm}$$

It is possible to find L trough the law of sine. Furthermore, it is possible to state L as a cos function of the length X.

$$\frac{2x + 90}{\sin 30} = \frac{x}{\sin(180 - 65,2)} \rightarrow$$

$$L = \frac{(2x + 90) * \sin(180 - 65,2)}{\sin 30}$$

R_{gy} is also a component force derived from R_g trough sine. Adding this in addition to the safety factor of 7 and that the gas spring can withstand 5 times its force gives:

$$450 \text{ N} = \frac{7}{5} * \frac{\frac{G * 433 \text{ mm}}{\sin 30}}{\sin 65,2}$$

Solving for x gives a length of 80mm.

At the time of writing Landgraff only had a satisfactory gas spring with a stroke length of 100mm. Using this would increase the safety factor to 8. This will also lower the resultant forces for the rest of the system. This will result in a lower need for additional structure to accommodate for stresses. It is unsure whether the 100mm gas spring will result in a heavier fixture after all the supporting structure has been added. Further research and analysis must be conducted on this subject, but that is out of the scope of this thesis.

4.10 Choosing gas springs

The gas springs chosen for this product are blockable gas springs. This means that they are pressurized and lockable in any position. These were chosen based on the insight from the paramedics, and the testing that was done. A bit of assistance when elevating the patients back would be beneficial. The blockable gas springs are available with several different amount of pressures. The amount of pressure translates to how easy it is to adjust the backrest. High pressure will make lifting the patient easy, but at the same time harder to push the backrest down. In an ideal situation different pressures would be user tested

to find out what they preferred. For this project there is neither time or budget for that. The second best option was to look at the Cirrus stretcher which was presented at the visit at the base in Trondheim. The mechanism in that stretcher is the same as the one selected in this project. Operating the mechanism on the Cirrus stretcher is smooth. That is also the impression given from the paramedics. It was therefore decided to use the same amount of pressure. The angles and dimensions of the two stretchers and mechanisms will differ a bit. This means that 450N might feel different in the two stretchers. To assure finding a good balance, it was chosen to use blockable gas springs with adjustable pressure.

Landgraff AS is a supplier in Norway that has a large selection of gas springs. If bought from them, the appropriate gas spring would be a F10-23 blockable gas spring with stroke length of 100 mm and a force of 450 N.

BLOKKERBARE FJÆRENDE GASSFJÆRER

F10-23 BLOKKERBAR FJÆRENDE GASSFJÆR

· Styrke:	150-1200 Newton
· Progresjon:	35%
· Stempelstang:	Ø10 mm forkrommet stål
· Sylinderrør:	Ø23 mm sortlakkert stål
· Fester:	Elforzinket stål
· Std. slaglengder:	20, 25, 30, 35, 40, 50, 60, 65, 70, 80, 90, 100, 110, 120, 130, 135, 140, 150, 160, 165, 180, 200, 210, 220, 230, 250, 300, 350, 400, 450, 500
· Std. lengde:	$L=2 \times H + 90$ $GL=L+L1+L2$

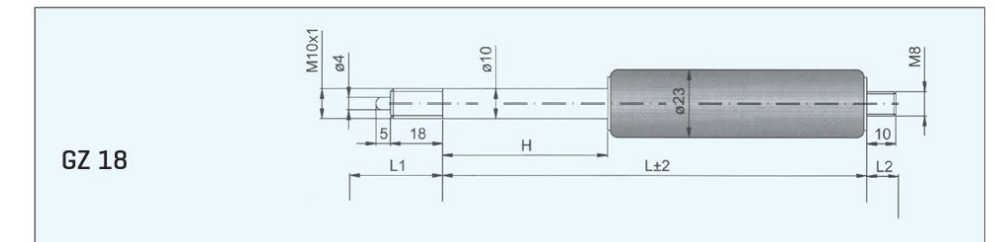

Bestillingseksempel: F10 23 0050 1 0190 GZ18 GZ10 250N

Figure 78. Best suitable blockable gas spring from Landgraff AS. [Landgraff, 2023]

4.11 Design of the backrest

The rescuebag is currently fastened with straps using the brackets as seen on figure x. When having an elevated backrest hinged at recess 2, the strap has to be mounted on the backrest instead of bracket 2 and 3.



Figure 79. Current spread of straps

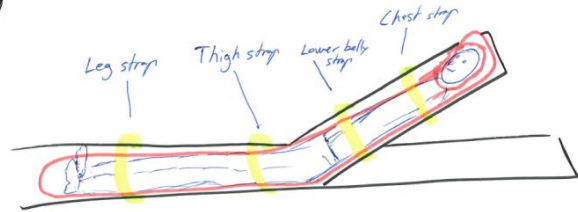

Figure 80. Spread of straps when the backrest is elevated.

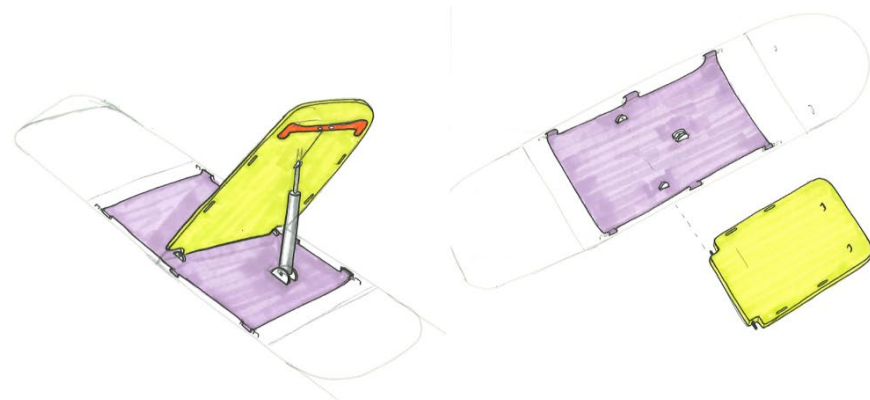
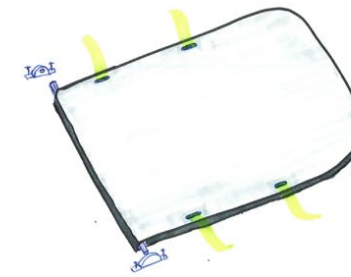
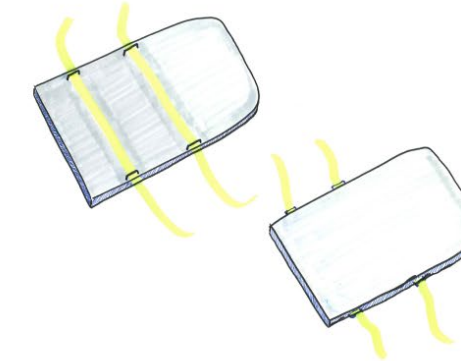

Figure 81. Illustration of what the concept 1 would look like together with the other parts.

Different solutions of locations for the straps on the backrest



Concept 1. Holes for straps built into the backrest.



Concept 2. Brackets mounted on top, or on the side of the backrest.

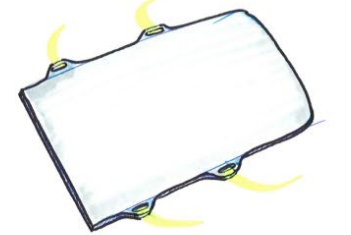

Concept 3. Holes for straps built into wider parts of the backrest.

Figure 82. Different ways to fasten the strap for the rescue bag to the backrest.

Another aspect was the fastening of the head part of the rescue bag. Without securing the head part the head would be able to bounce back and forth as the stretcher moves in terrain. Both requirement 13 and 14 is affected by this. Therefore it was decided that a fastening for the head part was needed.

#	Needs	Relevance
13	Mechanism does not move in rough terrain	•••••
14	Ergonomics	•••

Table 6. Needs to be taken into consideration when developing the backrest.

Figure 85. Backrest with concept 1 head protection using concept 1 fastening of the straps. This head protection is similar to the one existing in the FG-stretcher.

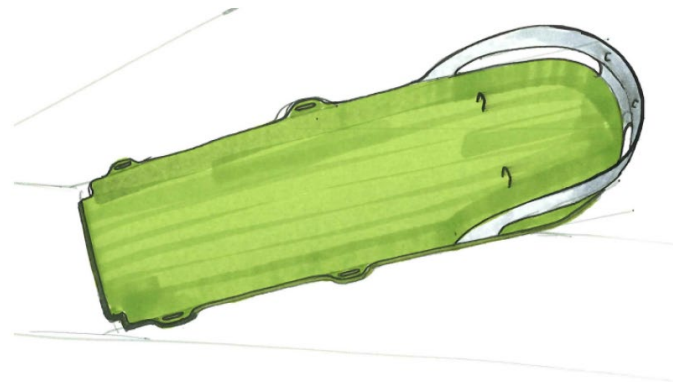
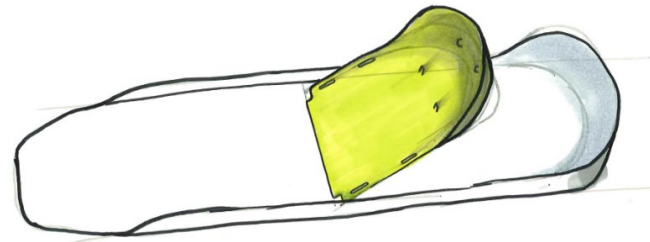

Figure 84. Backrest with concept 2 head protection using concept 3 fastening of the straps. This headrest has holes to reduce weight and only material to support the fastening points.

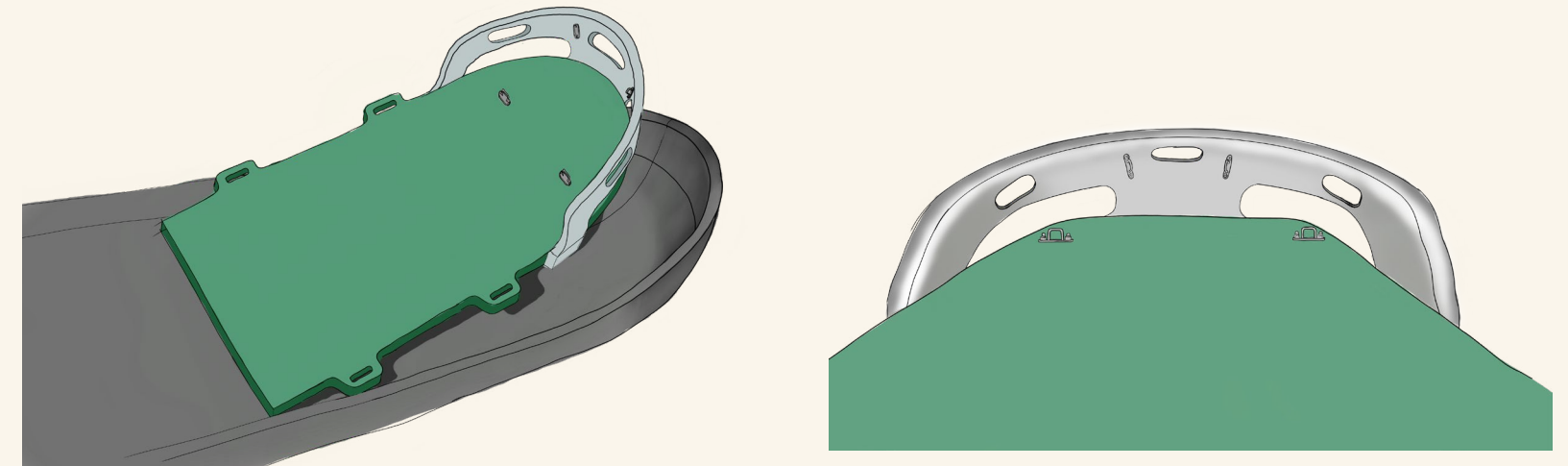

Figure 85. Illustration of the final design of the backrest.

Both for manufacturing and weight purposes the concept 2 head protection was chosen. This is also similar to the one designed by Borgen and Strand in their D9 project.

The head protection is thought to be manufactured as a separate part, and bolted to the backrest.

The backrest should be as wide as possible to provide support to the patient. More accurately, the fastening for the straps on the backrest must be wider than the outer sides of the double layered straps. If the fastening of the straps are narrower than this, the strap and the rescue bag will curl up. The width between the points where the strap is double layered is 440 mm.

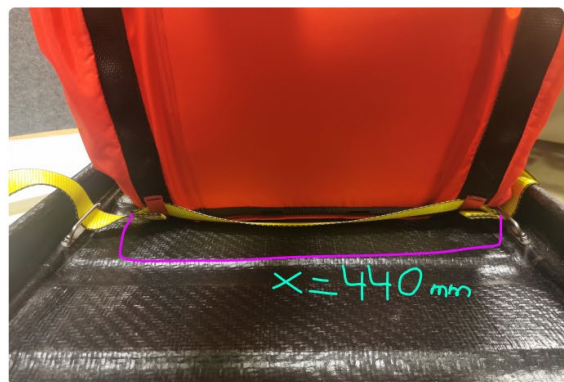
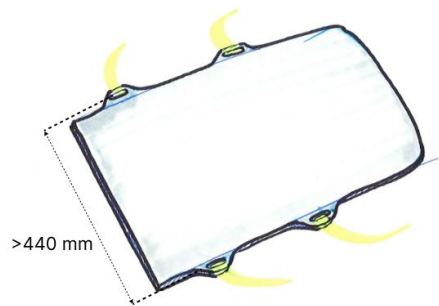

Figure 86. Minimum distance between the brackets for the rescue bag straps.



The backrest is 21 mm wide, and lays on top of the gas spring with a diameter of 23mm. A recess can be built maximum approximately 1/3 into the backrest. This means that the minimum distance between the backrest and the stretcher is $21\text{mm} - 23 \times \frac{1}{3} = 13\text{mm}$.

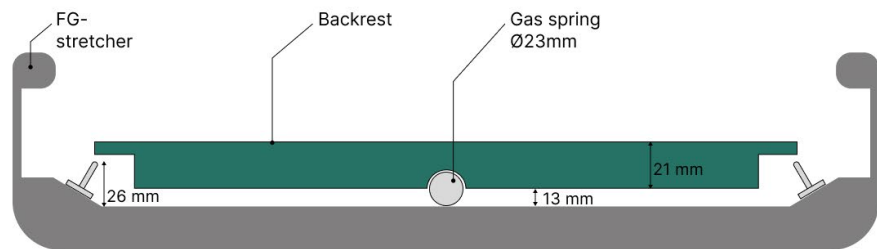

Figure 87. Section view - Front

4.12 Detailing the backrest

How long can the backrest be?

When measured in the stretcher, a 192 cm long patient will require a 800 mm long backrest to be fully supported.

Measured from the centre of recess 2, there is only room for a backrest of 700 mm. However, as on the original stretcher, the head support on the rescue bag is mounted higher. Utilizing the FG-stretchers curve it is possible to create a mounting point for the head support further up as shown in illustration x.. and thereby get the 800 mm needed for the rescue bag.



Figure 88. Section view - side. FG-stretcher and rescue bag

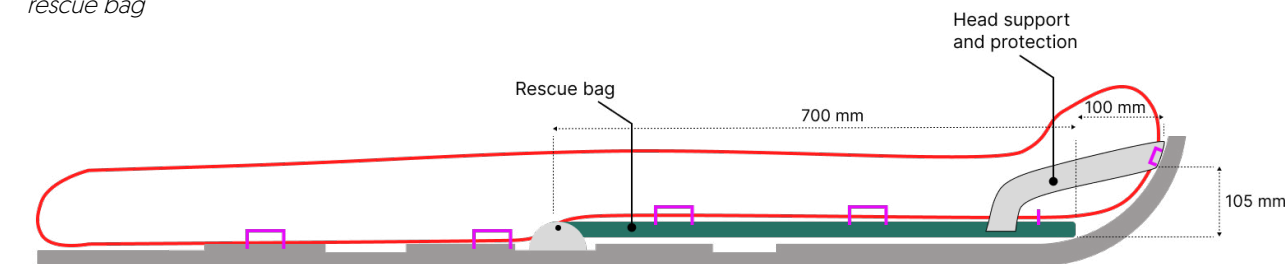

Figure 89. Section view - side. FG-stretcher, backrest and rescue bag

4.12.1 Composite materials

Using a composite structure for the backrest will potentially result in a lightweight strong and stiff structure. As this material combines the properties of different materials. Having a lightweight core to add geometrical stiffness and a strong and stiff material at the edges maximises the mechanical properties of both [Chawla, 2013]. Høiset has some experience working with carbon fibre composite materials through working with Revolve NTNU. The materials presented in this thesis will be based on his previous experience. This involves the selection of prepreg twill fibre, core material and the thickness of a single sheet of fibre. The last one is an empirically measured value. The materials in question is hexply 1450/50%/220H4/HTA-3K, Divinycell H100 and 0,23mm.

Calculations of a composite material is challenging. They are complex systems with unique buckling characteristics and have sometimes unpredictable behaviour. As shown in the thesis submitted by Robert D. Story, the results of theoretical calculations have a discrepancy from the real values even with complex calculations [Story & 2014]. As these calculations are outside the scope of this thesis a simplification system is set up. The plate gets considered as a multi-material beam with a moment load. By doing this it is possible to use the method of equivalent area. This is done by increasing the stiffness of one of the materials geometrically. By increasing the cross-section by a factor of n it is possible to emulate two materials of different stiffness as the same material. The new cross-section is considered to be made completely out of material 1 as shown in figure 90 [ecourses, 2023].

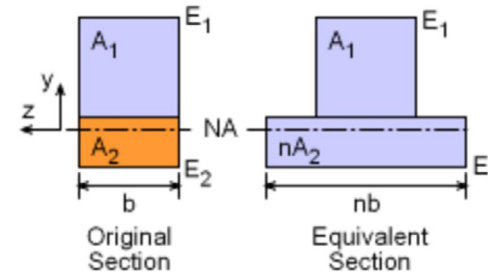

Figure 90. Method of equivalent area. increasing the width of one cross-section by a factor n [ecourses, 2023].

The increasing factor n is defined as [ecourses, 2023]:

$$n = \frac{E_2}{E_1}$$

Note that the scaling must only be done in the horizontal direction not the vertical. Due to the changed geometry a new neutral axis and center of mass must be determined. The total bending stresses present in the components is now as follows:

$$\delta_{b-1} = -\frac{M * y}{I} \quad \delta_{b-2} = -n \frac{M * y}{I}$$

Where I is the second moment of area of the full cross-section.

4.12.2 Emod of carbonfiber

Determining the elastic modulus of carbon fiber reinforced polymer (cfrp), or any fiber reinforced structure, is dependent on the direction of the fiber. Since the polymer consists of thin fibers held together by a matrix, the mechanical properties are dependent on the direction of the fibers. Fibers have a good resistance to stretching, but poor towards buckling. Also, the strength of the fibers does not affect the material when force is applied perpendicular to the fibers [Chawla, 2013].

One method to obtain greater strength in this direction is by utilizing twill fibers. This is a weaved fiber structure that gives added strength in both 0- and 90-degree direction of the fiber. By using twill fiber, the weakest direction is 45 degrees from the original direction [Chawla, 2013].

Determining the elastic modulus of the carbon fiber in use is dependent on the specific fiber, matrix, and layup. A layup is the different directions of fiber utilized. For this product it has been decided to use three layers of twill fiber. The majority of forces is assumed to be applied along the center axis if the stretcher as this is where the mechanism will be placed. To add further stiffness and strength to the system a layer of twill at a 45-degree angle was added. For simplicity the same layup was used on for both sides of the plate.

The calculations performed to determine the total E-modulus of the fibers can be seen in figure 91. The complete derivation of the formulas used can be found in attachment 2.

Outer skin : 0, 45, 0
 Inner skin : 0, 45, 0

E - mod
 $E = V_1 E_1 + V_2 E_2$ Strong Weak

OBLT :

1.	0	cos alpha	cos^2 alpha	$\frac{E}{4} E_K$
2.	0	1	1	E_K
3.	90	0	0	0
4.	-45	-1/2	1/4	$\frac{1}{4} E_K$

$E_{N,\alpha} = \frac{\sigma_N}{\epsilon_N} = \left(\frac{\sigma_{comp}}{E_{comp}} \right) \cdot \frac{\cos^2 \alpha}{\cos^2 \alpha}$

$E_{\alpha} = E_{comp} \cdot \cos^4 \alpha$

$E = \sum E_i V_i = \int_{-90}^{90} + \int_{45}^{90} + \int_{-90}^{0}$

$= \frac{2}{6} E_K + 0 + \frac{2}{6} \left(\frac{1}{4} E_K \right) + \frac{2}{6} E_K + 0 = \left(\frac{2}{6} + \frac{2}{24} + \frac{2}{6} \right) E_K = \frac{5}{12} E_K$

Figure 91. Calculation of elastic modulus of carbon fibre composite plate.

The elastic modulus of the fiber has been set to 400GPa [Cha, Kim, Ryu, & Hong, 2019]. Resulting in a total elastic modulus of the carbon fiber layup of 500/3 GPa.

This elastic modulus does not describe the total modulus of the CFRP as there is another component present. The fiber in question has a fiber to matrix volume of 50%. The elastic modulus of the specific epoxy used in the fiber is not specified, but based on a study conducted by Cha et al it has been set to 5GPa [Cha et al., 2019]. By using a weighted average, the final elastic modulus becomes:

$$E_{CFRP} = V_1 * E_1 + V_2 * E_2 = \frac{1}{2} * \frac{500}{3} + \frac{1}{2} * 5 = 85,86 GPa$$

Using this elastic modulus and the elastic modulus given in the datasheet for the core material, attachment 3.

By performing the same calculations as described in the calculations for the cross-section of the cross brace on pages 123-125, the stresses present in the plate can be determined. In order to keep the calculations as conservative as possible the system was defined as a beam with a fixed support in one end and a force applied on the other end. This results in a significantly higher momentum and bending stress than applied in real life. This is done because the calculations are very simplified and an attempt to overcompensate and produce a strong product. The force applied is a point mass of 30 kg, and the total length of the plate is set to 800mm. There will also be added a safety factor of 8. The complete calculations can be seen in figure 92.

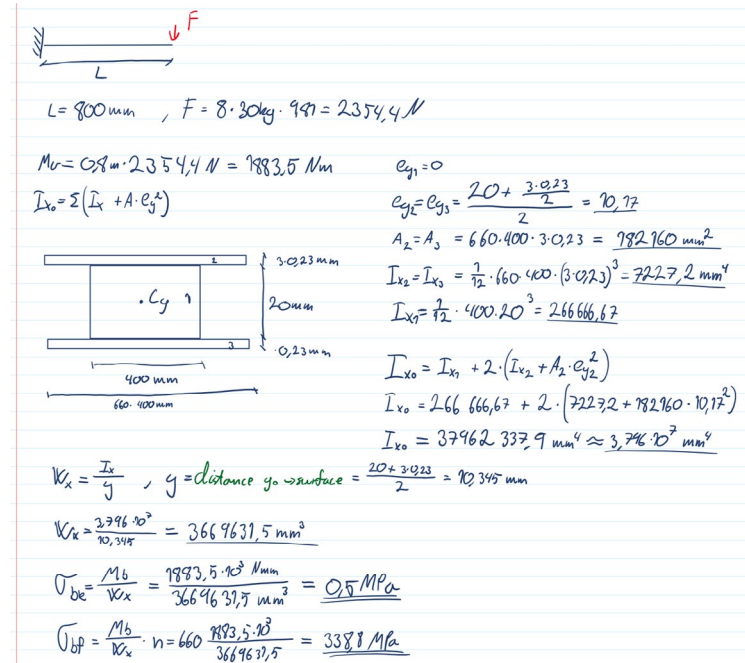
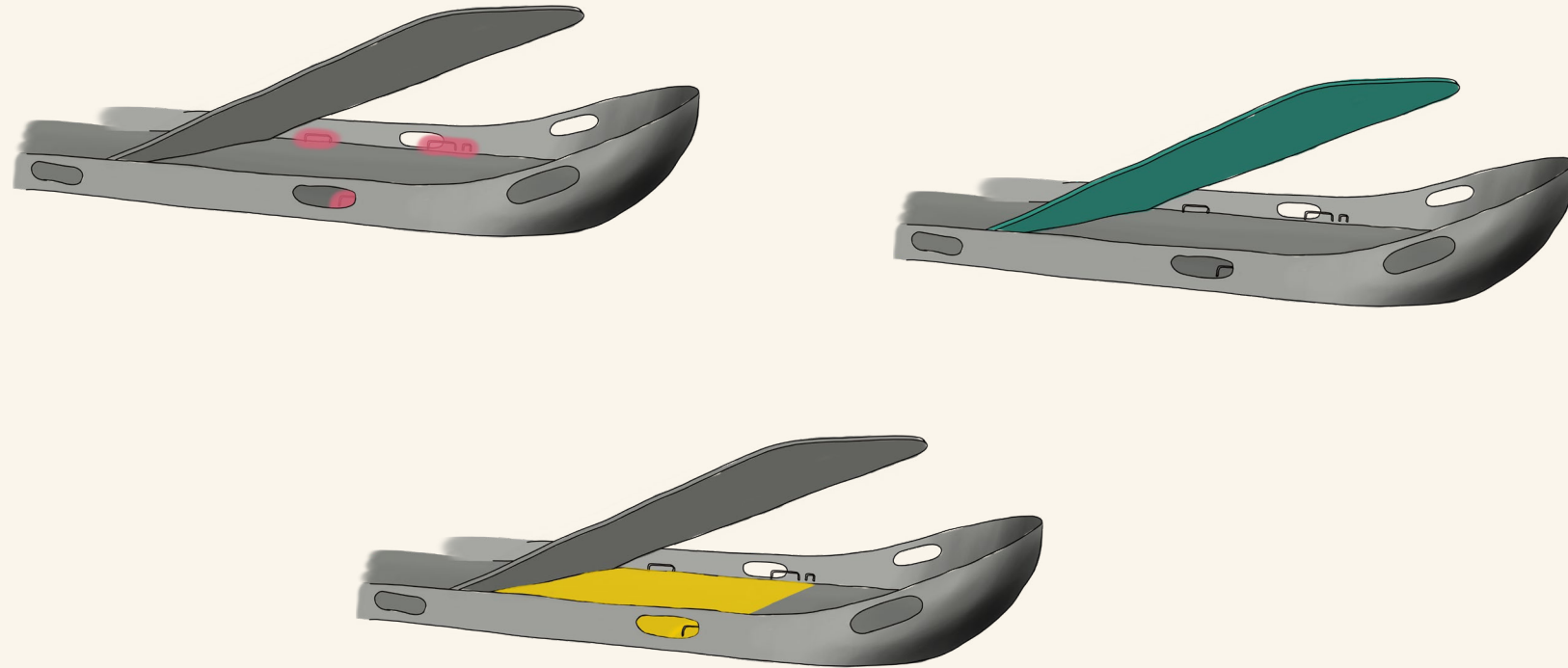

Figure 92. Calculation of stress in composite beam using the equal area method.

The tensile yield strength of CFRP varies greatly based on the fiber, and Hexcel does not state mechanical data for their products. Therefore, the base values set by Truong, Tran, & Choi at room temperature serves as an estimate [Truong, Tran, & Choi, 2019]. This gives a tensile yield strength of roughly 600 MPa. neither the carbon fiber and the core will yield under this load. The layup and composite construction is considered to be strong enough for this application.

A carbon fiber plate like this would need inserts for each attachment point to avoid delamination. This is considered a part of the design for final production and is outside the scope of this thesis.

5. PRODUCT DEVELOPMENT



5.1 Attaching the mechanism to the stretcher

This aspect of the project turned out to be a lot more comprehensive than assumed. There are a lot of criteria which comes into play. Easy installation and removal, ergonomics and small dimensions are some of them.

As mentioned earlier it was also stated that no modifications could be made to the original stretcher. Meaning no new fastening points for bolts etc could be made. This meant that the new solution had to be specifically developed and adapted to the brackets that are there already.

Highlighted in figure x are the needs from the requirement specification that are affected by the fastening mechanism, the backrest and/or the plate.

#	Needs	Relevance
1	Low weight	•••••
2	Easily maneuverable size	••••
3	Easy to install and remove	••••
4	Easy to operate when installed	•••••
5	Can achieve at least 30°	•••••
6	Can be used in multiple stretchers	•
7	Can handle high stress and vibrations	•••••
8	Can fit all patients regardless of size	••••
9	Can be used in different temperatures	•••••
10	Can lock at a given angle	••
11	Long lifespan	•••
12	Assisted lifting	••
13	Mechanism does not move in rough terrain	•••••
14	Ergonomics	•••
15	Certification for use	•••••
16	Can be folded with the stretcher	•
17	Legal fastening of stretcher to helicopter	•
18	Better straps to secure the patient	N/A
19	Smooth operating. [No sudden movements]	•

Table 7. Needs that are relevant to the development of the fastening mechanism.

The brackets marked in pink are the ones used to attach the rescue bag to the stretcher today. Six of these are considered to be useful to attach another part. Forward these brackets will be referred to as bracket 1, bracket 2 and bracket 3.

Notice that bracket 1 and 3 interferes with the carrying handles.



Bracket 1



Bracket 2



Bracket 3

Figure 93. Brackets relevant for fastening mechanism.

From the calculations the gas spring shall be mounted 330 mm from the backrest hinge. As it was desired to put both the hinge and the fastening for the gas spring in one of the recesses to keep the total build as low as possible.

By user testing and measuring it was decided that the hinge had to be in recess 2. 330mm from the middle of recess 2 is slightly off the middle of recess 4. From the middle of recess 2 to the middle of recess 4 it is 305mm. This resulted in two options

Option 1. Keep the angle α , and allow the maximum angle of the backrest be slightly larger than 30°. [31,7°]. This reduces the distance y , which gives the force in gas spring a shorter arm.

Option 2. Keep the maximum angle of the backrest to 30° by reducing the angle α . The lower the angle α is, the less strength it will take. The distance y remains the same.

Option 1 was chosen because the distance (y) of the arm played a smaller role in the force equation than the angle (α).

Both options reduces the exciting picture, but option 1 also gives a higher maximum angle of the backrest which is positive. Option 1 is therefore chose.

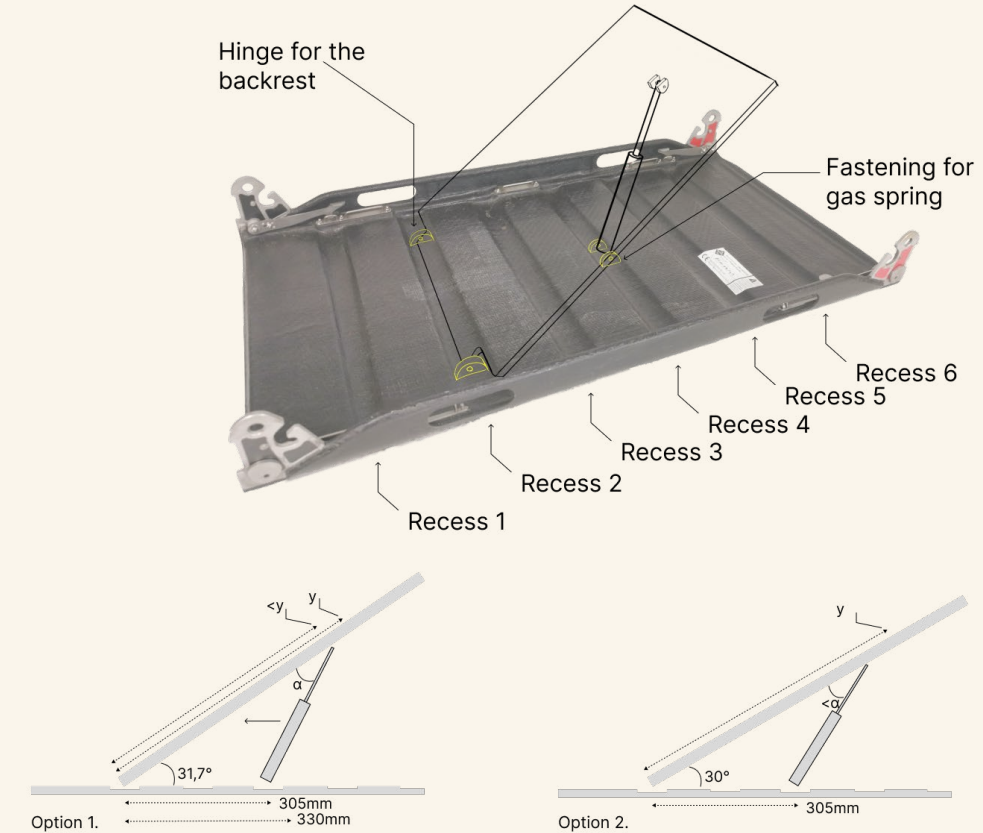

Figure 94. Location of the gas spring in the stretcher.

When developing the fastening mechanism, the backrest and the metal plate there are several aspects to take into consideration.

Ergonomics

When lifting the stretcher rescuers often use the handles in the middle. As mentioned in figure x, these handles are very close to the brackets.

As there isn't allowed to make holes in the stretcher for new brackets, dam dam dam

Developing a mechanism that attaches to the existing brackets while simultaneously is simple and fast to remove from the stretcher turned out to be a complicated feat.

The designspace for an easy removable fastening solution varies for each bracket. The variation is a consequence of the location of the carrying handles and the handle that secures the different parts of the stretcher together.

The designspace for each bracket is illustrated as a combination of the pink and turquoise color. The two colors illustrate the available designspace above and beneath the bracket.



Figure 95. Illustration of the stretcher being carried by four persons using the handles.

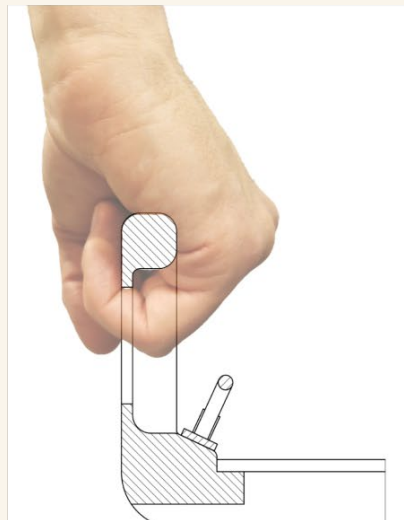

Figure 96. Illustration of section view showing approximately how much space the hand takes up.

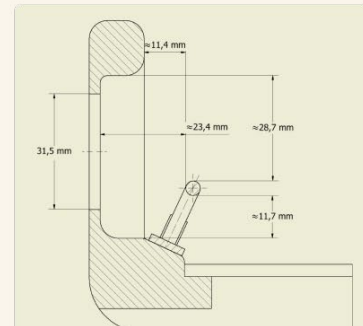

Figure 97. Section view of one side of the stretcher where the brackets overlap with the carrying handle.

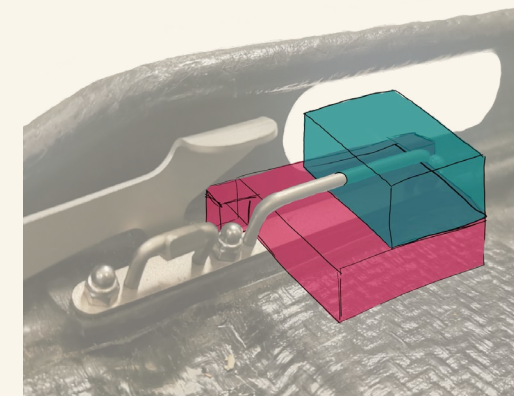

Figure 98. Designspace bracket 1

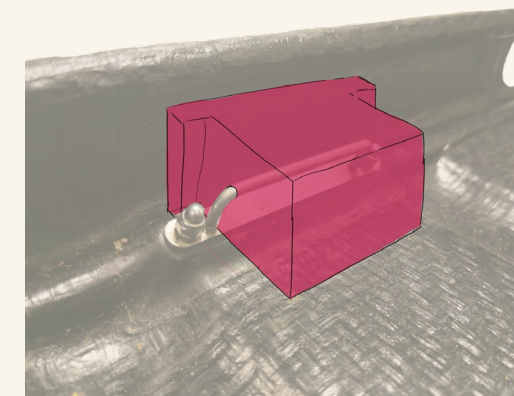

Figure 99. Designspace bracket 2

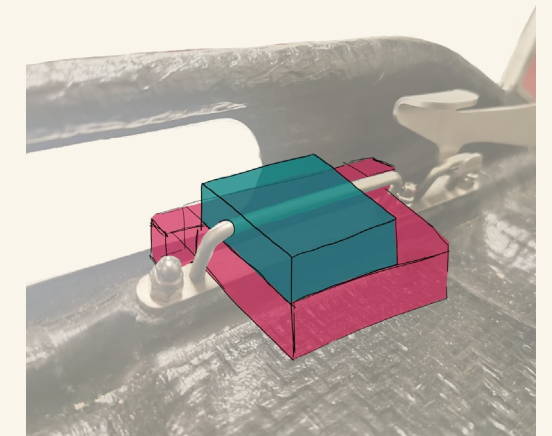
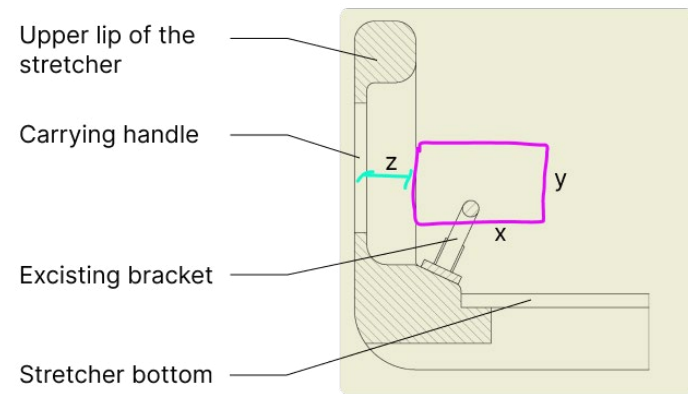

Figure 100. Designspace bracket 3



For a mechanism within the designspace there can be made some statements. For the dimensions x, y and z in a section view the following will apply.

Height y: For strength and stiffness, based on the second moment of area, this height should be as high as possible. For ergonomics when carrying the stretcher it should be as low as possible.

Width x: For the backrest this width should be as low as possible because the backrest is fastened in the same location. For structural properties the width should be as big as possible.

Dimension z: Influences width x and ergonomics for carrying the stretcher.

Figure 101. Room for fastening mechanism on bracket.

Sketches of initial ideas for fastening mechanism

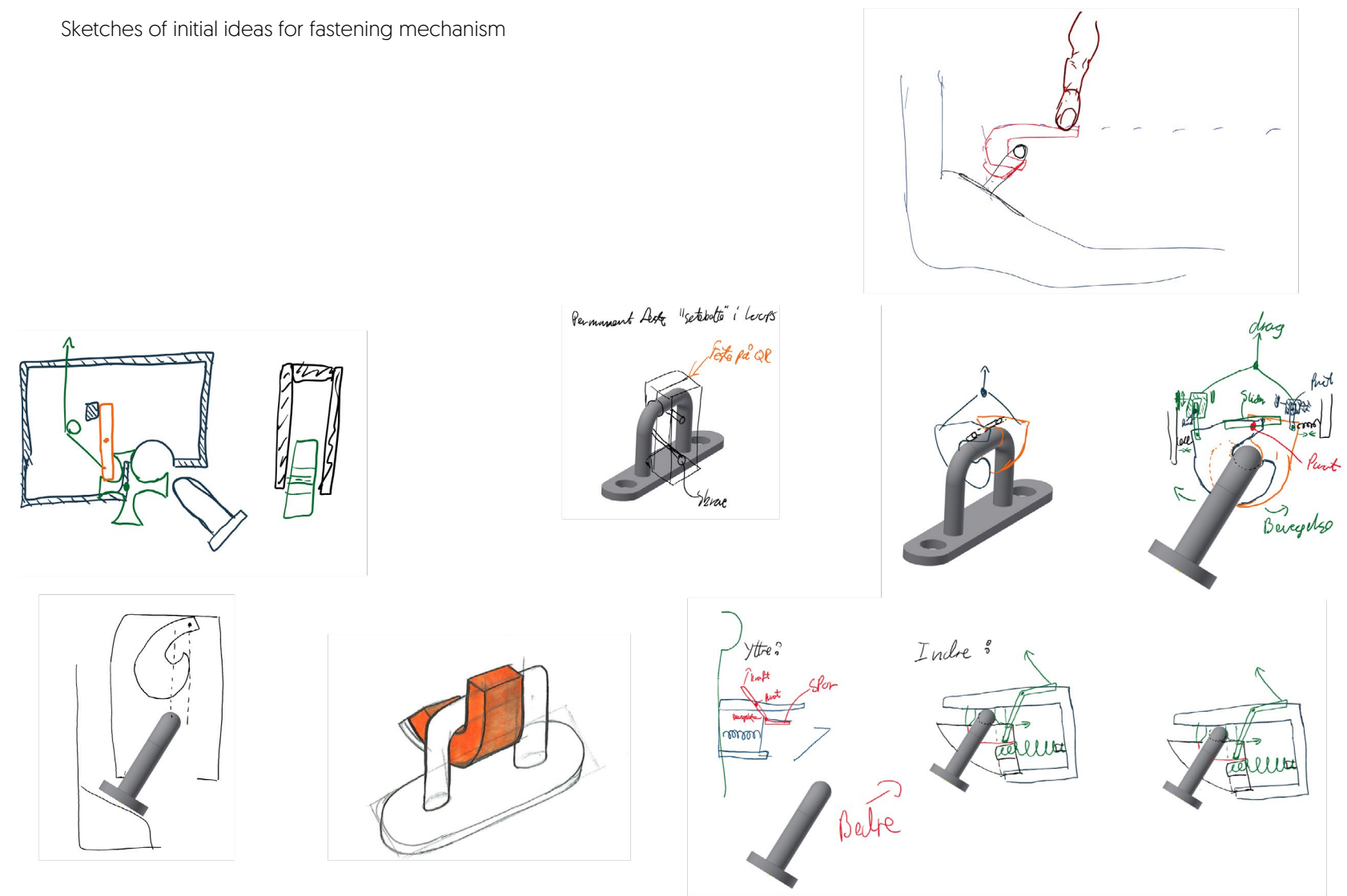

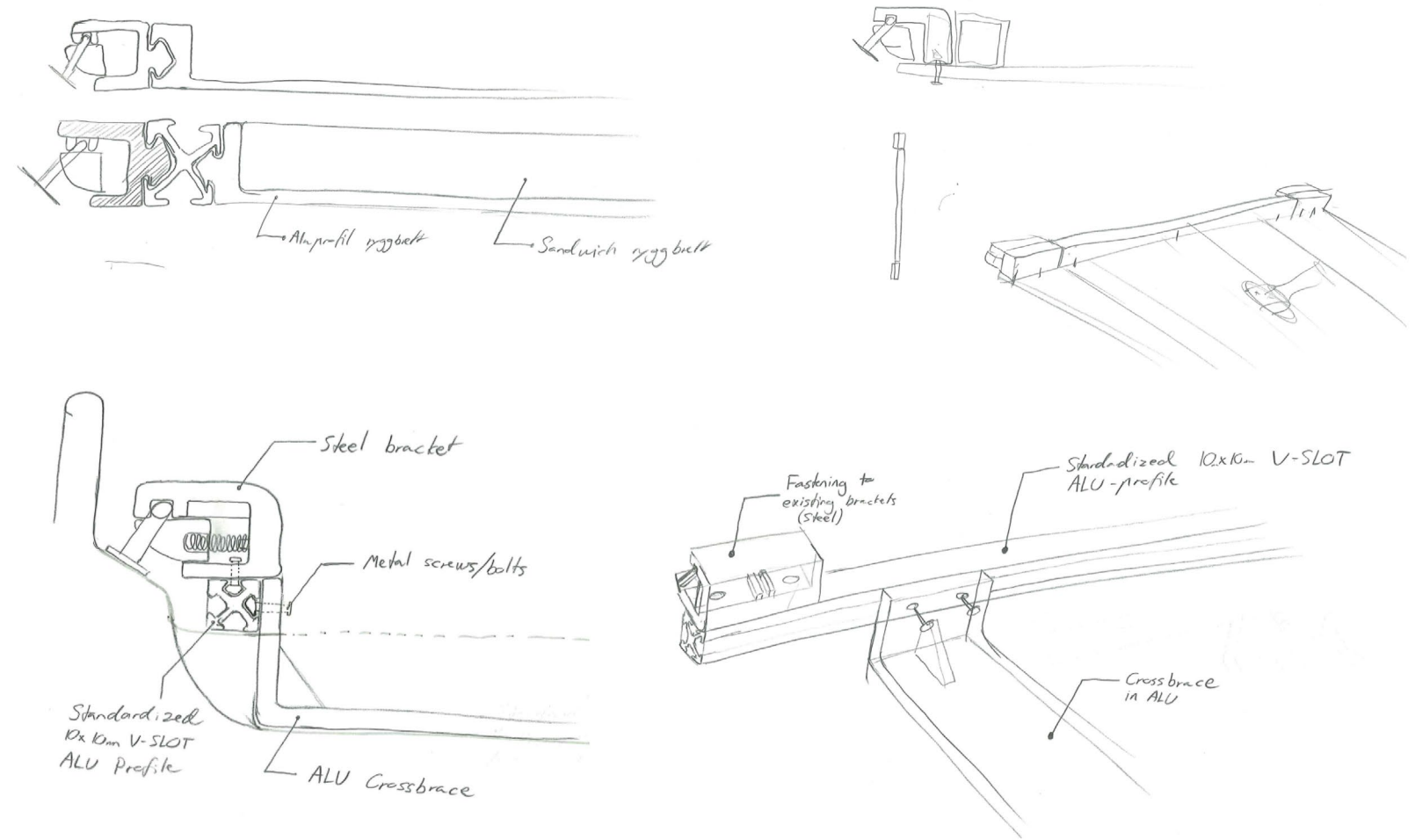
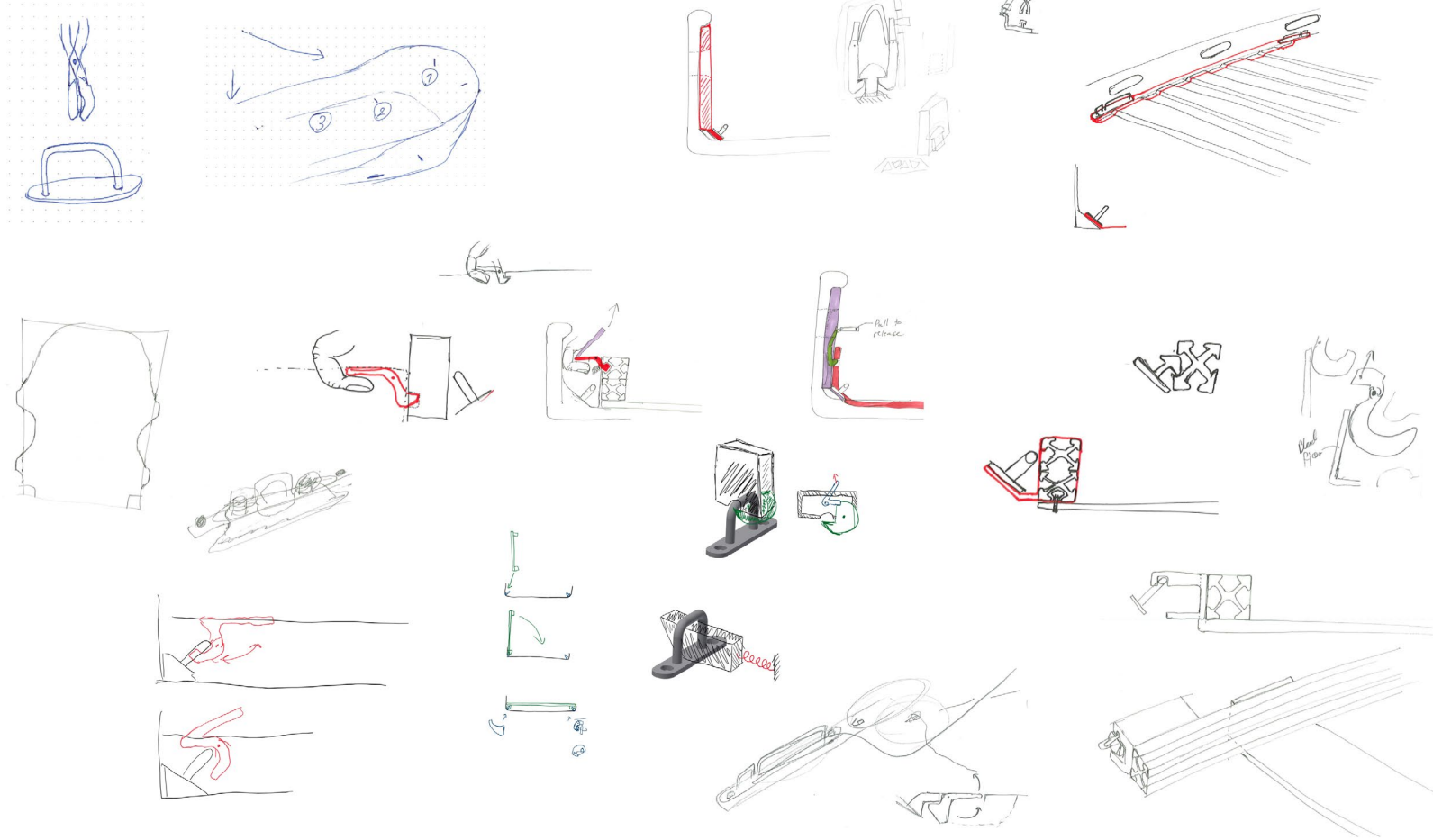

At this point a new challenge was discovered. Because the backrest is hinged at recess 2, bracket 1 is in front of the backrest. This means that the strap still has to go through the bracket at this location. Although there could be enough room for both a fastening mechanism and the strap inside the bracket, there is a risk for the strap to get jammed. To prevent this there can be made a similar bracket for the strap on top of the fastening mechanism.



Figure 102. Illustration of fastening mechanism beneath the strap. Creates a risk of jamming the strap.

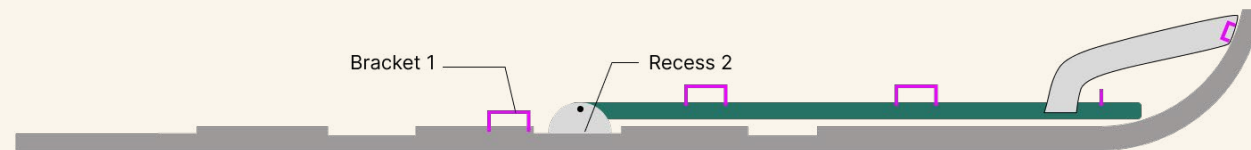

Figure 103. Illustration of location of new fastenings for the strap on the backrest.

5.2 Two concepts for brackets

From the criteria of not making changes to the structural parts of the stretcher, it was regarded beneficial to propose two concepts.

The first concept is mounted to the stretcher by removing bracket 1 and 2 on both sides, installing the plate, and then bolt the brackets back on top of the plate.

From measurements, there are approximately 6,0 mm of threads left with a minimum of 5,6 mm and maximum of 6,7 mm when the brackets are in place. Putting on a 3mm plate makes room for 3 mm of threads. A worst case scenario of 2,7 mm of threads was calculated to be more than enough.

This solution is a more permanent solution as tools are needed to install and remove the entire device. However, it is not necessary to remove the entire device to remove the backrest.

6mm of threads left



~3 mm of threads left

3 mm ALU plate



Figure 104. Illustration and measurement of available room for a plate beneath the existing brackets.

Minimal thread engagement

One of the requirements for the fixture is to not interfere with the structural integrity of the stretcher in any way. Since one of the concepts involves fastening a flat bar underneath the existing fastening points. These are fastened with acorn nuts to a piece of threaded rod coming out of the stretcher. By putting a 3mm piece of flat bar underneath these the thread engagement will decrease. In order to do this, it is necessary to prove that the stretcher is unaffected.

This can be done geometrically using the formula for tensile stress area and minimal thread engagement for ISO threads [LINOWES & 2023; Solidworks, 2023]. The calculation are as follows:

Tensile strenght area :

$$A_s = \left[\frac{d_3 + d_2}{2} \right]^2 \cdot \frac{\pi}{4}$$

$p = \text{Pitch (top-top)}$, $n = \text{threads per mm} = \frac{1}{p}$, $d = \text{nominal bolt diameter}$

For ISO :

$$\left. \begin{aligned} d_3 &= d - 1,2268 \cdot p \\ d_2 &= d - 0,6495 \cdot p \end{aligned} \right\} \text{ gives } A_s = \frac{\pi}{4} (d - 0,9382 \cdot p)^2$$

$$\rightarrow A_s = \frac{\pi}{4} \left(d - \frac{0,9382}{n} \right)^2 \quad m5 \approx 14,78$$

$$L_e = \frac{2 \cdot A_s}{0,5 \pi (d - 0,64952 \cdot p)}$$

$$L_e = \frac{2 \cdot 14,78}{0,5 \pi (5 - 0,64952 \cdot 0,8)} = 4 \text{ mm}$$

The firmness class of the bolt and nut was found to be A2-70 with a yield strength of 450MPa and an ultimate strength of 700 MPa [volksbolts, 2023]

By measuring the free threads present on top of the bracket, the lowest measured value recorded is 2,7mm. This is less than the minimum requirement. However, there it is sill possible that the thread will be stronger enough. This can be examined by using ISO 898. This method uses a single full thread of engagement to calculate the force required to strip the first thread. Once the first is stripped, the rest is sure to follow. Since this calculation only use a single full thread, Le only needs to be larger than the thread pitch. For M5 this is 0,8mm [Engineers_edge_3, 2023] The nominal sheer area of the single thread is calculated trough the steps found in [Engineers_edge_1, 2023] with the values and variables found in [Engineers_edge_2, 2023; Engineers_edge_3, 2023]

$$A_s^{nom} = \frac{\pi}{4} \left(\frac{d_2 + d_3}{2} \right)^2$$

$d_2 = \text{Basic pitch diameter external thread ISO 724}$
 $d_3 = \text{Basic minor diameter external thread} = d_1 - \frac{H}{6}$
 $H = \text{Height thread triangle ISO 68-1} = \cos 30^\circ \cdot p$

M5

$$d_2 = 4,480, \quad d_1 = 4,019, \quad d_3 = d_1 - \frac{p \cos 30}{6} = 3,903$$

$$A_s^{nom} = \frac{\pi}{4} \left(\frac{4,480 + 3,903}{2} \right)^2 = 13,8 \text{ mm}^2$$

$$F_{max} = 450 \cdot 13,8 \text{ mm}^2 = 6,2 \text{ kN}$$

$$F_{max} = 700 \cdot 13,8 \text{ mm}^2 = 9,7 \text{ kN}$$

The total force needed to shear a single thread on the bolts are 9,7kN.

5.2.1 Concept 1

The concept consists of two parts. One part is fastened beneath bracket 1 and 2, while the other part is fastened onto the first part using a quick release mechanism. This mechanism will make it easy to remove the backrest if needed.

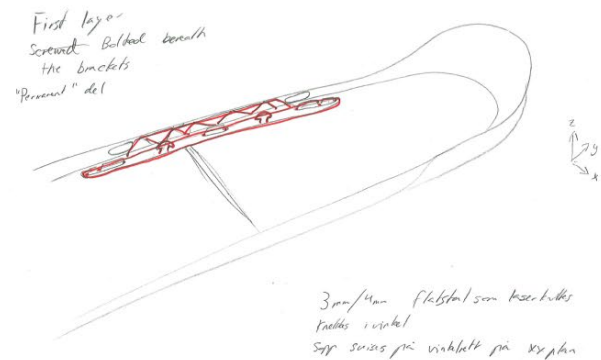

Figure 105. Fastened beneath bracket 1 and 2

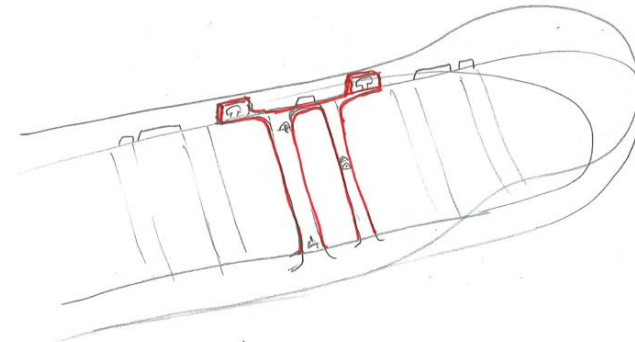

Figure 106. Fastened onto the first part using a quick release mechanism.

5.2.2 Concept 2

From the criteria of not making changes to the structural parts of the stretcher, it was regarded beneficial to propose two concepts.

The first concept is mounted to the stretcher by removing bracket 1 and 2 on both sides, installing the plate, and then bolt the brackets back on top of the plate.

From measurements, there are approximately 6,0 mm of threads left with a minimum of 5,6 mm and maximum of 6,7 mm when the brackets are in place. Putting on a 3mm plate makes room for 3 mm of threads. 3 mm of threads is calculated to withstand xxx N, which is more than enough.

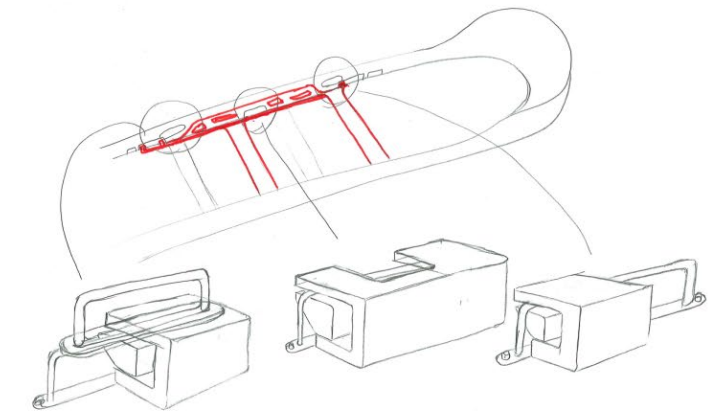
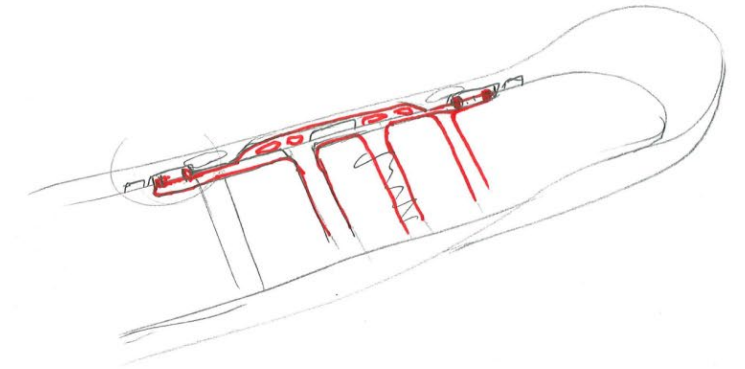

Figure 107. Three fastening mechanisms the respective brackets.

Suggested method for installation

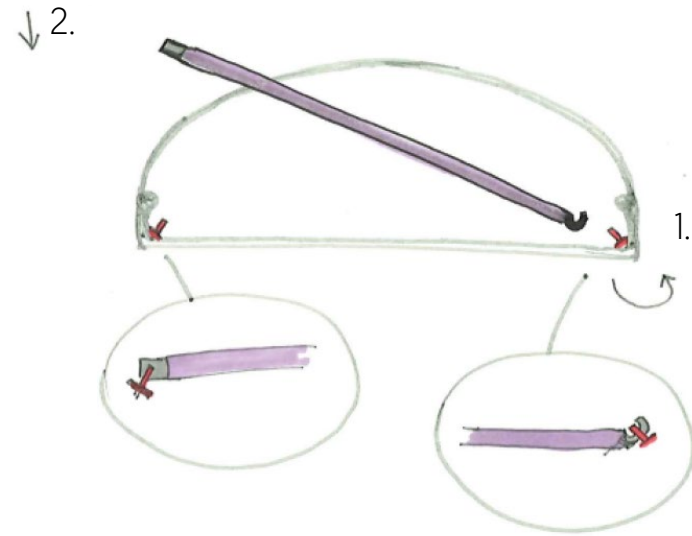

Figure 108. Front view. Suggested method for installation.

For both concepts

Because the brackets doesn't line up with the recesses, another question is raised. There are two ways of fixating the right hand side.

Suggested method to install the plate into the stretcher. One side is hooked while the other contains the fastening mechanism. This reduces the need for fastening mechanisms, and simultaneously makes it faster and easier to remove the installation from the stretcher.



Figure 109-110. Option 1 of braces in the stretcher. Front view

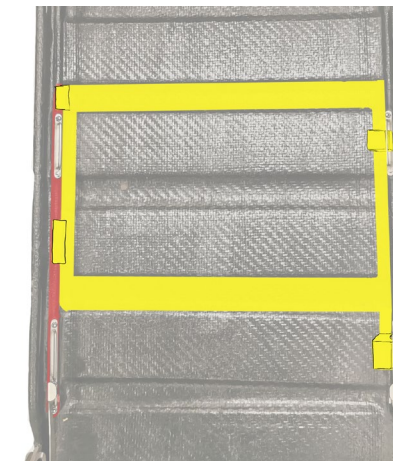

Top view

Option 1

The right hand side is hooked onto the existing brackets. The hooks braces are not aligned with the braces.



Figure 111-112. Option 1 of braces in the stretcher. Front view



Top view

Option 2

The right hand side has a longitudinal brace fastened beneath the brackets similar to the left hand side. This brace has new brackets specifically designed to be hooked onto by the yellow braces.

5.3 Materials

Based on the aforementioned concept of geometrical stiffness it is desirable to use a strong material with a low density. The total budget for a potential production was never defined and will not be a factor when defining materials. The fixture should also be able to withstand the cold Norwegian winters without altering the mechanical properties in a major way. Additionally, the materials of the fixture should be highly resistant to corrosion and not require corrosion inhibiting maintenance.

Based on these criteria aluminium stands out as an excellent option. Combining a low density with desirable mechanical properties [Pedersen & Kaland, 2023]. Aluminium is highly resistant to corrosion and has very little to no degradation in strength at sub-zero temperatures. Some alloys will even gain increased yield strength due to hardening in the colder

temperatures. Aluminium can also be alloyed with other elements to obtain different mechanical properties. Some of these alloys can also be heat treated to further alter the mechanical properties [Pedersen & Kaland, 2023]. These alloys tend to have a higher tensile strength [Sankaran & Mishra, 2017].

The aluminium alloy chosen for the structural parts of the fixture is 7075-T6. This is a 7000 series alloy meaning it is alloyed with zirconium and titanium. The suffix T6 references the specific heat treatment used on the alloy [Sankaran & Mishra, 2017]. This alloy has one of the highest tensile strengths of all aluminium alloys and is therefore commonly used in aircrafts, aerospace and defence applications. The tensile yield -and ultimate strength are 503 and 575MPa respectively [matweb, 2023].

5.4 Calculations for the gas spring

To determine the resultant forces produced in the fastening mechanism it is necessary to calculate the force in more detail. This time the weight of the patient is no longer perpendicular 500mm from the hinge. An offset has been added parallel to the backrest plane. After measuring 5 different students an average thickness of a human body was set to 230mm. The mass centre was set to the middle of the body 115mm above the plane of the backrest. The exact geometry was sketched up digitally to obtain as high accuracy as possible as seen in figure 113.

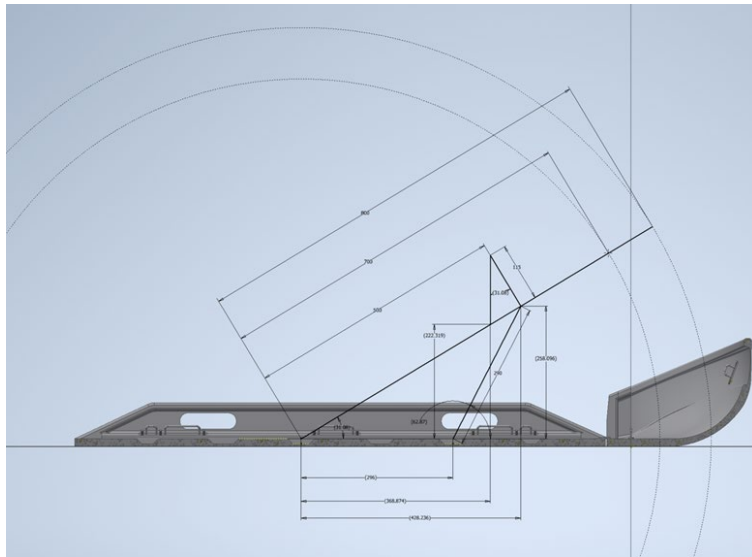

Figure 113. Detailed sketch of the measurements for the backrest etc etc

The system with forces applied can be seen below.

safety factor

$$F_g = 265 \text{ N} \cdot 5 = 1324 \text{ N}$$

$\sum M_A = 0$

$$F_g \cdot 368,9 - F_{By} \cdot 296 = 0$$

$$F_{By} = \frac{F_g \cdot 368,9 \text{ mm}}{296 \text{ mm}} = 1650 \text{ N}$$

$\sum F_y = 0$

$$F_{By} - F_{Ag} - F_g = 0$$

$$F_{Ag} = F_{By} - F_g = 326 \text{ N}$$

Calculating the vertical forces can be done as shown in figure 114
Method found in [Nilsen & Larsen, 2016]

$\sum F_x = 0$ For both systems yields:

$$F_{Ax} = F_{Bx} = F_{Cx} = 839 \text{ N}$$

$\sum F_y = 0$

$$F_{Cy} = F_{By} = 1650 \text{ N}$$

$\sum M_C = 0$

$$F_{By} \cdot 132,2 \text{ mm} - F_{Cx} \cdot 258,1 \text{ mm} = 0$$

$$F_{Cx} = \frac{F_{By} \cdot 132,2 \text{ mm}}{258,1 \text{ mm}} = 838,7 \text{ N} \approx 839 \text{ N}$$

Figure 114: Method and calculations to solve a statically indeterminable system by splitting it.
Method found in [Nilsen & Larsen, 2016]

Since this is a statically indeterminable structure, some simplifications must be made. The structure is split in the joint and assumed that no momentum is present in point C. This may not be the case, but a necessary simplification to continue [Nilsen & Larsen, 2016]. The horizontal forces can be solved as shown in figure 114.

5.5. Calculations for estimate of cross section of braces

Obtain a rough estimate of a geometry for the cross brace will serve as guidance for the design work in CAD. The cross brace is simplified to a beam with a fixed support in each end and one component of the resultant force in each end. This gives two systems one for the x component and one for the y component. For this thesis the focus will be on point B. This is done since the largest force is present here. Thus, using the cross section found in point B for point A will result in a structure satisfying all mechanical requirements. A free body diagram, shear force diagram, momentum diagram and calculations for the horizontal forces and momentums can be found below. [Johannessen, 2002; Nilsen & Larsen, 2016].

This must be done for the vertical forces as well. The diagrams, momentums and resultant forces can be seen below.

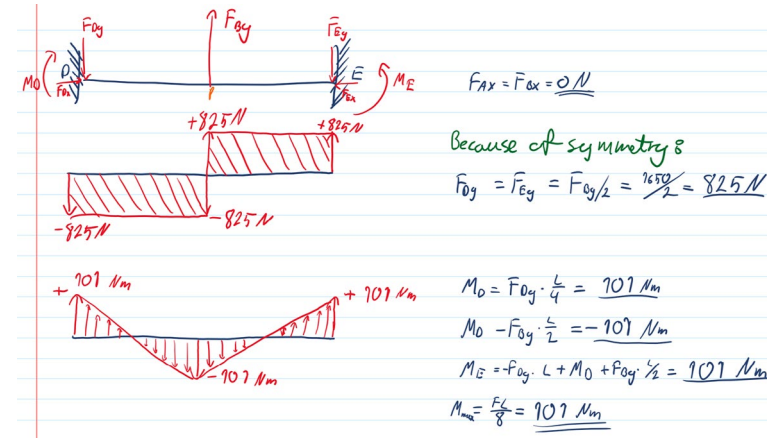

Note that the vertical force in B is reversed. This is done as an approximation of a worst-case scenario. Since the crossbrace rest in the bottom of a recess, all force in negative direction caused by upwards acceleration of the helicopter will not contribute to bending stress. Reversing the direction of the vertical force emulates a helicopter accelerating downwards. Since 1G acceleration downwards is freefall, resulting in no forces on the system, the safety factor of 5 emulates a total acceleration of 6G. This is a highly unlikely scenario other than in a crash. However, since this is a two-dimensional model, the momentum from sideway acceleration relative to the direction of the gas spring is not accounted for. The force reversal will result in a momentum in the cross brace similar to what would occur during sideways acceleration. A more complex three-dimensional model should be set up to obtain accurate results. This is however outside of the scope of this thesis and the indication given by these systems are considered sufficient.

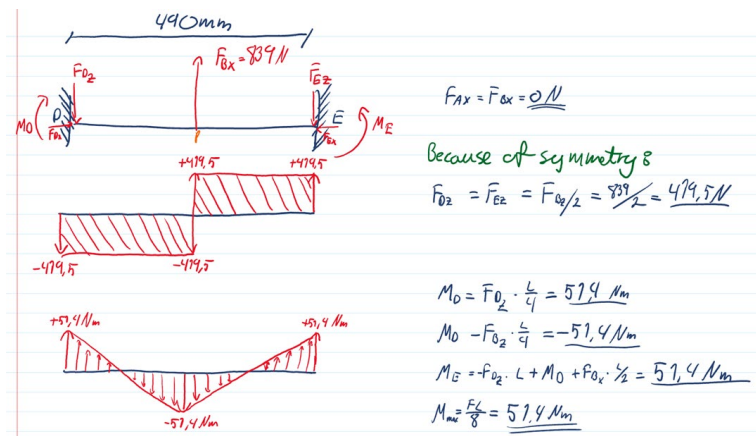

The crossbrace will have a base structure of a 5mm flatbar lying in the bottom of a recess. The recess in question has a width of 35mm for point B. Using the field of mechanics of materials to determine the stresses from bending in the flatbar. By using the cross-sectional modulus and the maximum bending stress in the flatbar. This was first done for the horizontal cross section as this is the strongest axis with the least amount of force. The system and calculations can be seen below. [Johannessen, 2002; Nilsen & Larsen, 2016].

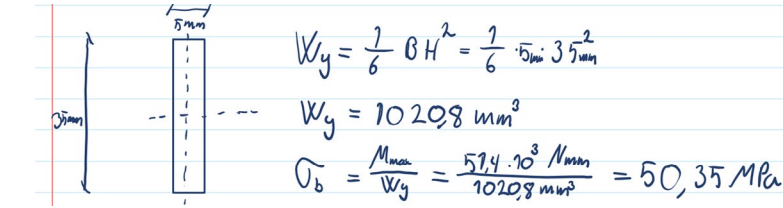

Where W_y is the cross-section modulus and δb is the bending stress. The result of 50MPa is below the tensile yield strength of the material and the crosssection is strong enough to in this direction to avoid plastic deformation with a safety factor of 5G. Performing the the same calculations for the vertical direction as seen below.

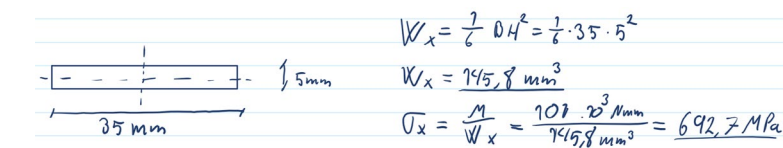

The stress in this direction is far larger than the tensile yield strength and additional geometry is needed. To keep the part simple and easily producible an additional piece of 5mm flatbar is added to the top of the one lying in the recess. This will be flipped 90 degrees relative to the existing one, as seen in figurexxx, to take advantage of geometry to increase the stiffness and strength. The ideal height of this needs to be determined. Hence, the system shown below.

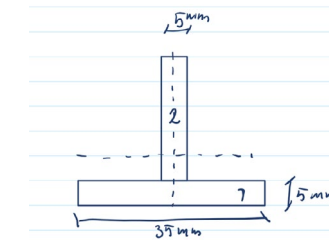

Using the method of combining cross-sections to determine the bending stresses in the system. Finding the second moment of area trough geometry keeping the height of 2 as the variable h. The calculations can be seen below. .

$I_{x_0} = \sum (I_x + A \cdot e_y^2)$, $e_y = |y_0 - y_1|$, $y_0 = \frac{\sum y \cdot A}{\sum A}$, $W_x = \frac{I_{x_0}}{y}$, $\sigma_b = \frac{M_b}{W}$
 $e_y = 2,5 + \frac{h}{2}$
 $A_1 = 5 \cdot 5 = 25 \text{ mm}^2$
 $A_2 = 5 \cdot h$
 $y_0 = \frac{5 \cdot 2,5 + 5 \cdot h \cdot (5 + \frac{h}{2})}{5 + 5h} = \frac{12,5 + 10h + \frac{h^2}{2}}{2(1 + h)}$
 $I_{x_0} = \frac{1}{12} \cdot 5 \cdot 5^3 + 25 \cdot \left(\frac{12,5 + 10h + \frac{h^2}{2}}{2(1 + h)} - \frac{5}{2} \right)^2 + \frac{1}{12} \cdot 5 \cdot h^3 + 5h \cdot \left(\frac{12,5 + 10h + \frac{h^2}{2}}{2(1 + h)} - (5 + \frac{h}{2}) \right)^2$

$$\delta_{tot} = \sqrt{\delta_x^2 + \delta_y^2} = 503 \text{ MPa}$$

The stress criteria is combined with the previous calculations on a single vertical flatbar with the variable h for the height. The stress in x direction remains unchanged to simplify the calculations. This will also help make the calculations more conservative. The final calculations of the system can be seen below.

Where:
 I_{x_0} = Second moment of area of the total structure
 I_x = Second moment of area of the individual components
 e_y = The eccentricity of the individual centre of mass to the total centre of mass
 y_0 = The height of centre of mass from bottom of horizontal flatbar
 y = The height of the individual centre of mass from the bottom of the horizontal flatbar

$W_x = \frac{1}{6} \cdot 5 \cdot h^2$
 $\sigma_b = \frac{M_b}{W_x}$
 $\sigma_{tot} = \sqrt{\sigma_b^2 + \sigma_y^2}$
 $\sigma_{tot} = \sqrt{\left(\frac{101 \cdot 10^3}{\frac{1}{6} \cdot 5 \cdot h^2} + 502 \right)^2} = 503$
 $\rightarrow h = 15,56 \text{ mm}$

All simplifications made yields a more conservative result. The height of 15,56mm on the reinforcement will reduce the stress to below 503 once the systems have been combined.

The stress requirement will be a combination of both stress in x direction and in y direction. Von Mises theorem is used for this combination and setting it equal to the yield strenght

5.6 Calculations for the fastening mechanism

The fastening mechanism must be strong enough to endure all the stress provided by the fixture. Evaluating the stresses present in the mechanism itself is not enough. The strength of the fasteners in the stretcher must also be analyzed.

Given the geometry of the brackets in the stretcher the system becomes a frame system. These systems have a tendency to be statically indeterminate, and this system is no different. Performing hand calculations on this system would be highly time consuming and the results would be suboptimal. Using a computerized model is preferable. The method chosen was FEM in ANSYS.

Setup

The material of the stretcher was found in a classified document, and was set with the following mechanical properties fig 115.

During a FEA analysis the meshing is of great importance to the final results. A quick analysis with a fine global mesh alongside qualified guessing helped determine the problematic areas in the model. These areas were treated with a much finer mesh. The settings and final mesh can be seen in the pictures on the right.

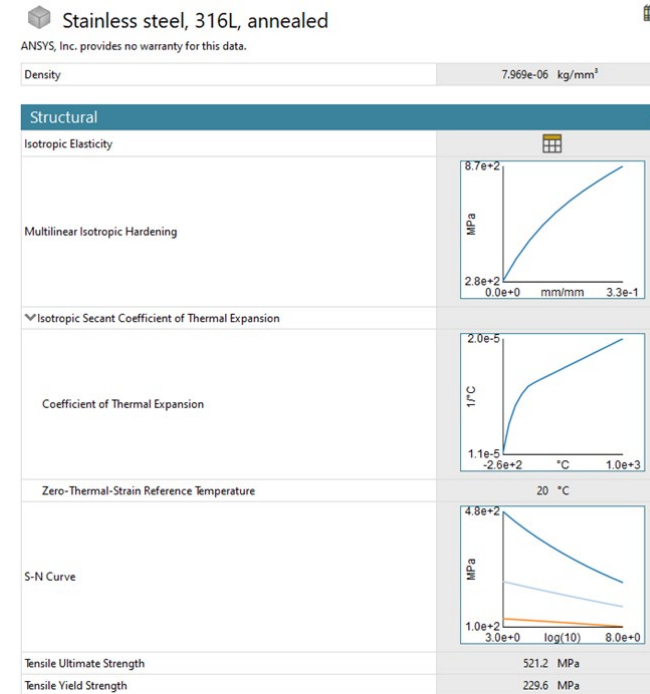
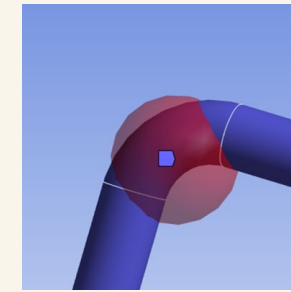
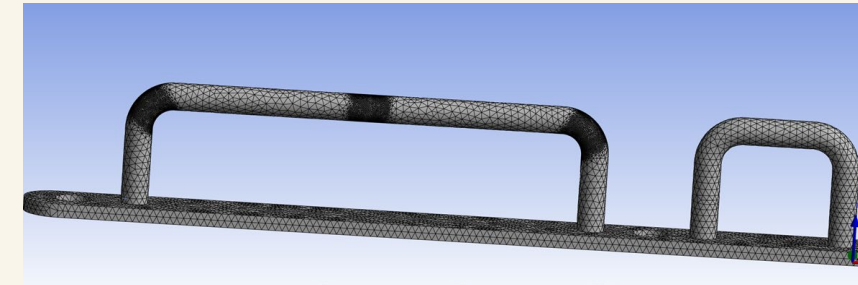
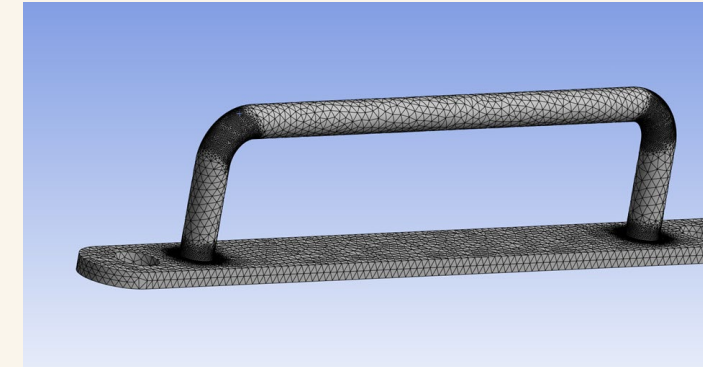
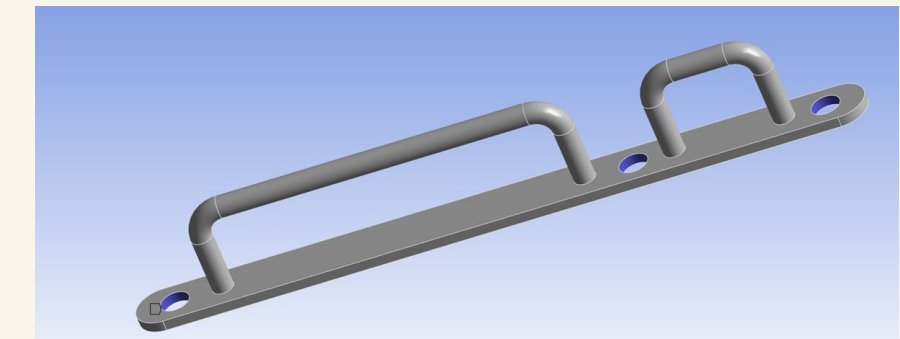

Figure 115. Material properties of 316L stainless steel.



The three mounting holes were set to fixed supports as shown below



For the main portion of the brackets a semi fine mesh was used with an element size of 1mm. for the areas with the largest stress concentrations a sphere of influence was created in the center with a radii of 4mm and element size of 0.2mm. All mesh was set to tetrahedrons for a more uniform result.

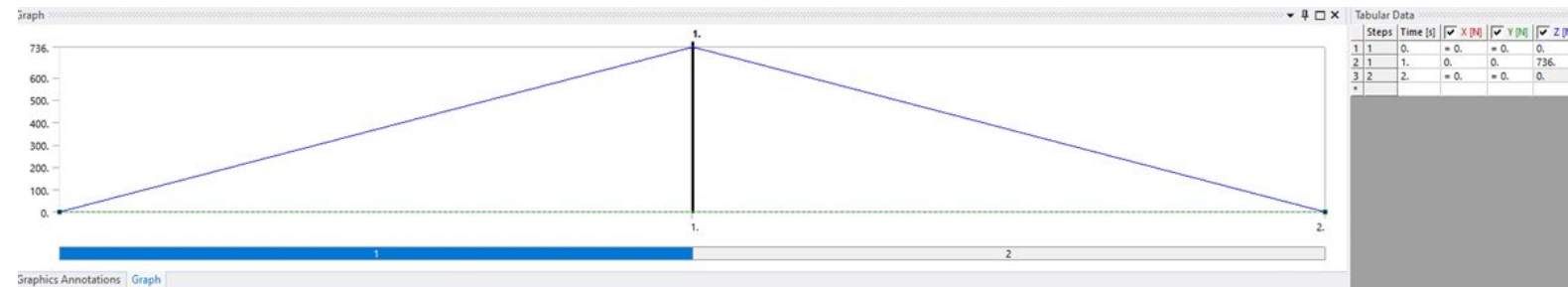

Figure 116. Forces applied to the system over time.

The forces applied used 2 steps to view the plastic deformation applied to the system. The forces varied in direction for the different loadcases to check out the direction given in figureXXX[den med båra og G krefter].

Example of force applied

The force was ramped from 100N to 1000N with 100N increments. After 1000N a cyclic load was applied to examine possible fatigue under repeated high stress. Y-direction had no significant weakness after 10 x 1000N. the remaining direction had issues at 700N 10x.

5.1.3 Results

- All of the brackets can handle 600N without permanent failure
- When force applied in y direction of the stretcher the force [kjervvirking i bunnen. Mesteparten overflatespenninger]
- When force is distributed on 4 or 6 brackets, the total Rm is well within the 8G requirement and some are within the official ones.

5.6.2 Fem analysis

The finite element method is a powerful tool for evaluating parts. By utilizing one of these tools it is possible to evaluate the strength of a given geometry. Using this to validate that a design is strong enough is a key element in product development. By using analysis in symbiosis with CAD it is possible to idealize a part by removing material where the stresses are low and adding geometry where stresses are high. If this symbiosis continues it will eventually reach a point of saturation with an ideal part as result.

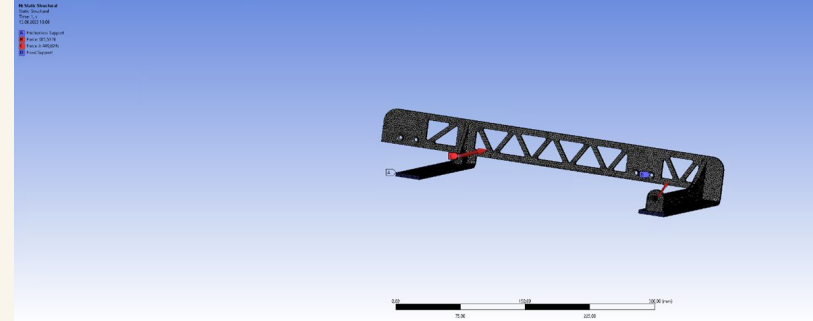

5.6.3 Forces in FEM

Before setting up analysis all forces must be mapped out and evaluated since this is a complex three-dimensional geometry it is difficult to provide accurate forces, but an estimate can be made. For the cross braces the force was set to be equal to the shear forces present in the two-dimensional system. Furthermore for the brace permanently fixated in the stretcher a force of 2kN was applied along with a moment of 300Nm revolving the x-axis.

For all analysis the material 7075-T6 was added with the following properties:

Property	Value	Unit
Density	2770	kg m ⁻³
Young's Modulus and Poisson's Ratio		
Young's Modulus	7.1E+10	Pa
Poisson's Ratio	0.33	
Shear Modulus	6.960E+10	Pa
Shear Modulus	2.660E+10	Pa
Tensile Yield Strength	4.3E+08	Pa
Compressive Yield Strength	4.3E+08	Pa
Tensile Ultimate Strength	5.017E+08	Pa
Compressive Ultimate Strength	0	Pa

Details of "Force 1"	
Scope	
Scoping Method	Geometry Selection
Geometry	1 Face
Definition	
Type	Force
Define By	Components
Coordinate System	Global Coordinate System
<input type="checkbox"/> X Component	419,5 N (ramped)
<input type="checkbox"/> Y Component	825, N (ramped)
<input type="checkbox"/> Z Component	0, N (ramped)
Suppressed	No

Details of "Force 2"	
Scope	
Scoping Method	Geometry Selection
Geometry	1 Face
Definition	
Type	Force
Define By	Components
Coordinate System	Global Coordinate System
<input type="checkbox"/> X Component	419,5 N (ramped)
<input type="checkbox"/> Y Component	162, N (ramped)
<input type="checkbox"/> Z Component	0, N (ramped)
Suppressed	No

5.6.4 Setups

For all cross braces a tetrahedric centred meshing was used and an element size of 2mm. in some instances where it was unsure if a hotspot was created due to geometry or to course meshing a finer mesh was put in place with an appropriate mesh size. All fastening points were set to fixed support.

To improve the performance of the analysis it was necessary to split the system in two equal parts. Frictionless support was used on this surface to emulate a mirrored part.

5.6.5 Results of FEM

Understanding the results of an analysis is important to implement changes. By examining hotspots of stresses, it is possible to determine if it is a real hot spot or one produced by the boundary constraints. i.e the analysis of the cross brace in the removable concept have two major hotspots. One by the holes for fastening and another on the cut edge. These are both potentially acceptable defects even though the resulting stresses are well exceeding the tensile ultimate strength. This is due to the bolt holes being defined as a fixed support. A fixed support denies all movement in and bordering the geometry selected. As the hole wants to deform ever so slightly it is denied by this constraint. This makes the transition infinitely stiff and results in unnaturally high stress concentrations. A bolt would be in place here and allow deformation. In addition, would the clamping force of the bolt relieve some tension and spread the point load on a larger area.

The other stress concentration found on the cut edge originates in a frictionless support. While great for simulating a cut part in some areas the frictionless also have some issues. It locks all

movement in one plane as well as the rotation of the bordering elements. This behaviour may result in unrealistic shear force or bending force. Using a full model will validate whether it is real or not.

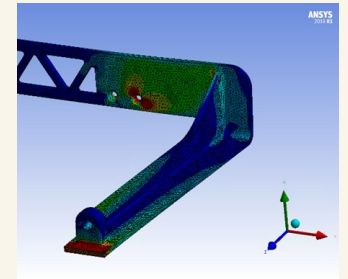

The parts analysed were only the ones deemed necessary and had sufficient data to defend the results. For a more complete look at the system, it would be necessary to build a large and complex model. This work and validating the calculations based on this model is outside the scope of this thesis.

5.6.6 Results

Cross brace for permanent concept.

Hotspots present in mirrored edge and holes.

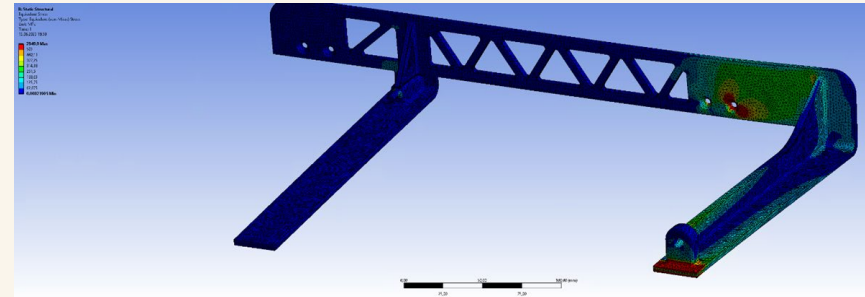

Crossbrace for removable concept.

Hot spots present around mirrored edge and fixed hole.

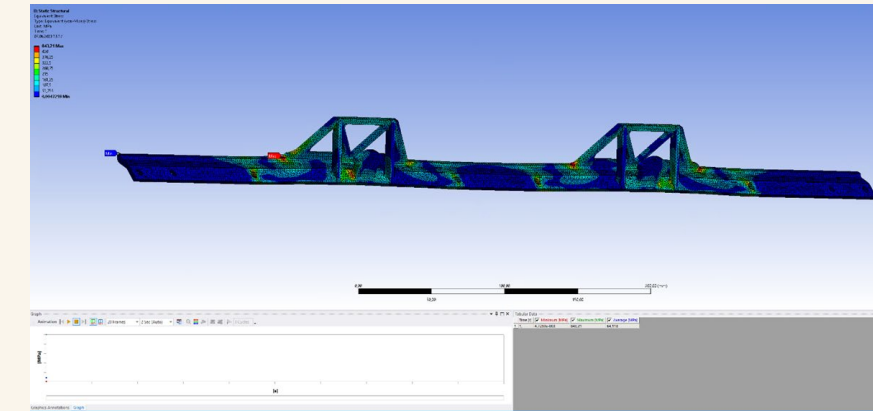
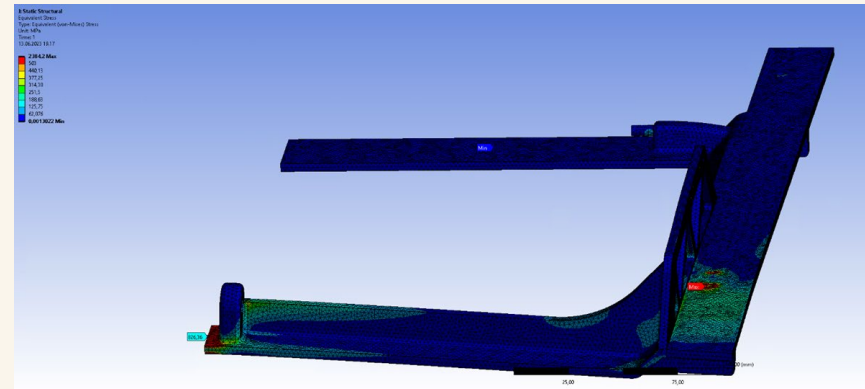

Permanent brace for the permanent concept.

Some stress concentrations can be seen. Some of these are caused by a lack of bonding to the surfaces this brace is resting on. This analysis had issues due to its complex setup and geometry.



Figure 117-118. Operating handle of the AC-stretcher.

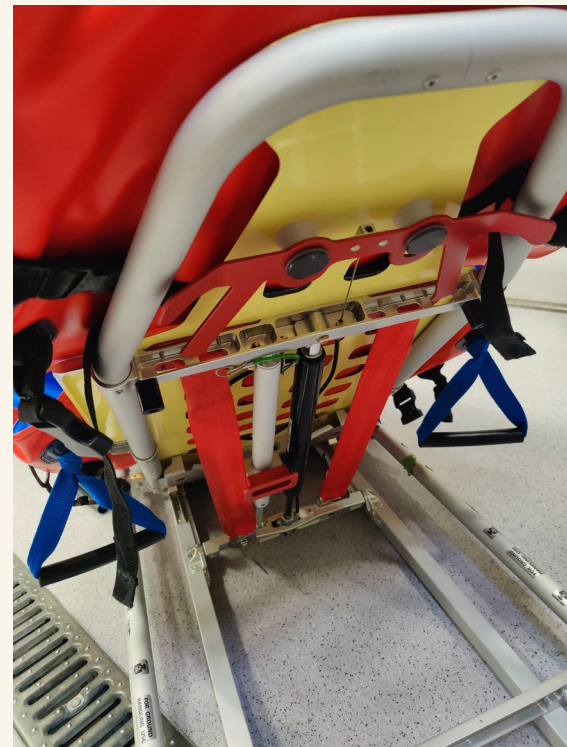

Due to limited time caused by the unexpected comprehensiveness of the fastening mechanism aspect, the operating handle has not been developed. It is however from the interviews with the user known that it is wanted to have a similar handle and function as the handle on the AC-stretcher.

6. FINAL CONCEPTS



*Estimated weight of fixture
3,0 kg*

6.1 Concept 1 - Permanent

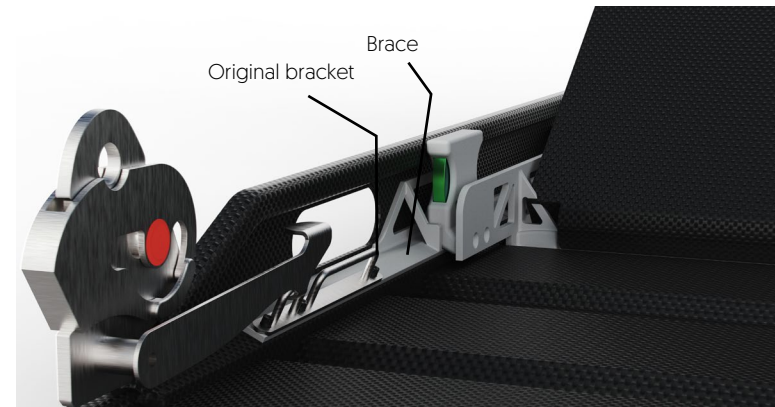

Figure 119. Right side from front. Notice the brace is fastened beneath the original bracket.

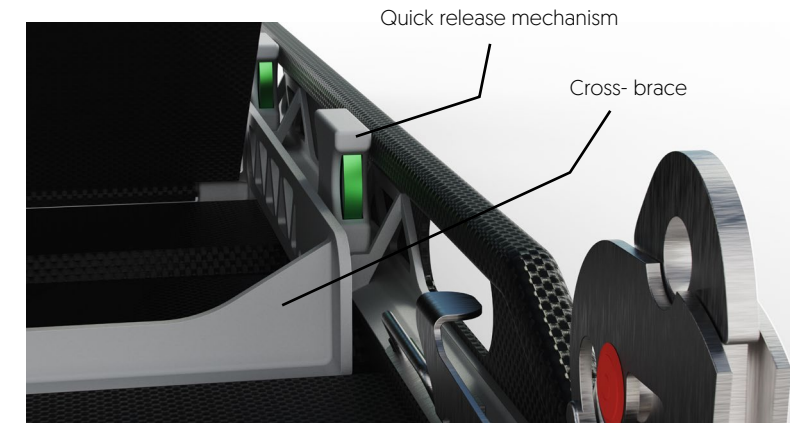
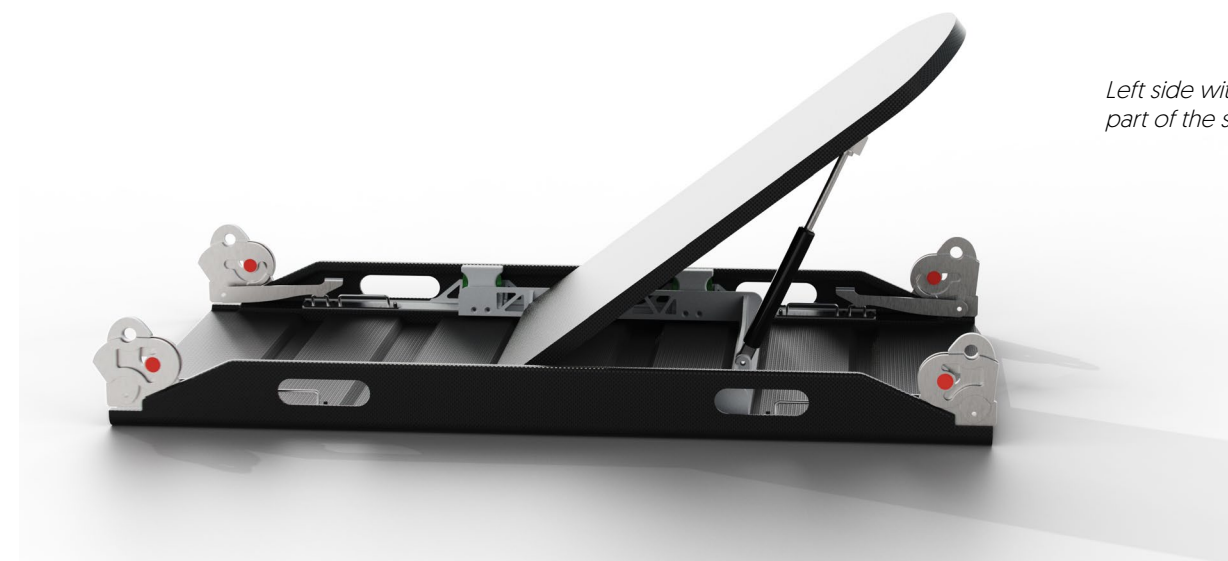

Figure 120. Right side from back. The cross-brace is fastened to the brace using a quick release mechanism.



Left side without top and bottom part of the stretcher

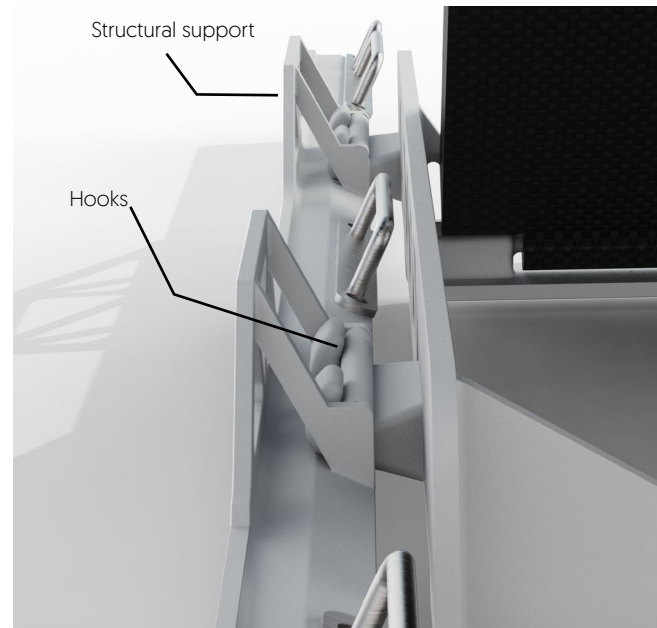

Figure 121. Closeup of the brace and the hooks that connects the crossover brace to the adjacent brace.

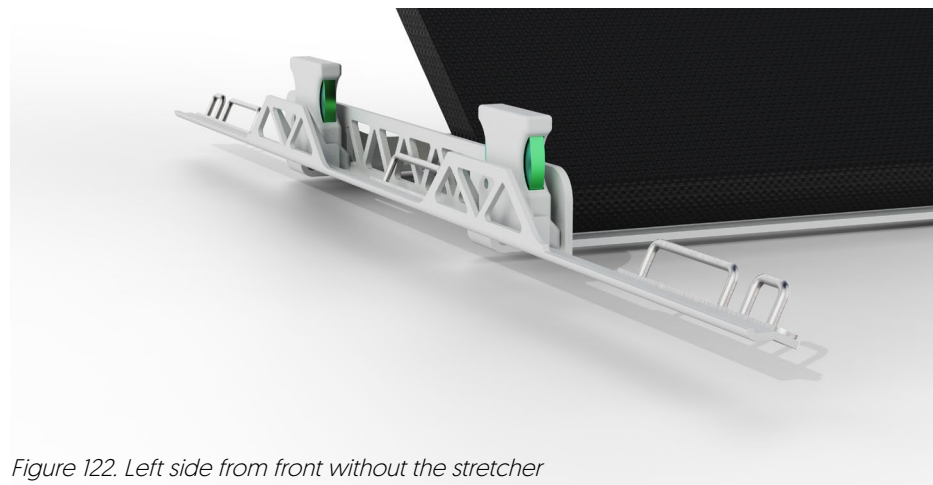

Figure 122. Left side from front without the stretcher



Figure 123. Back view. Notice the angle of the original brackets.

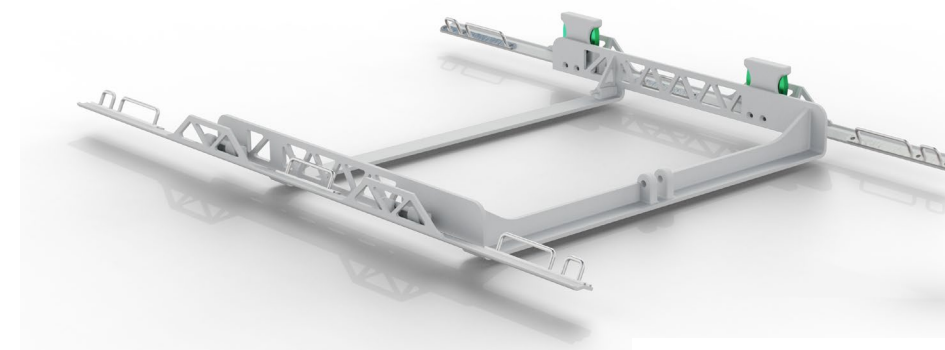

Figure 124. The entire fastening fixture

The quick release mechanism snaps onto the adjacent brace. A leaf spring would push the pins outwards, locking it in place.

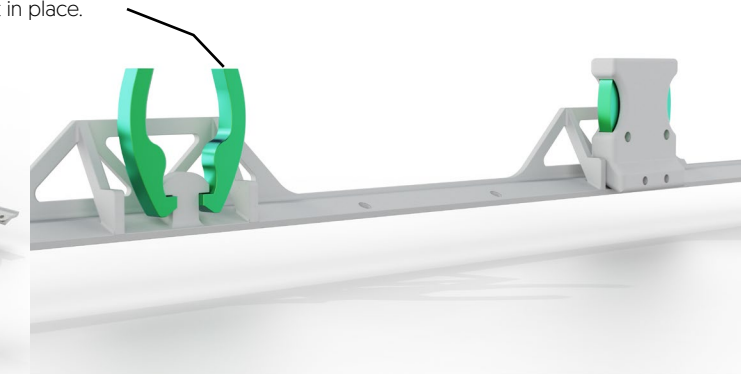
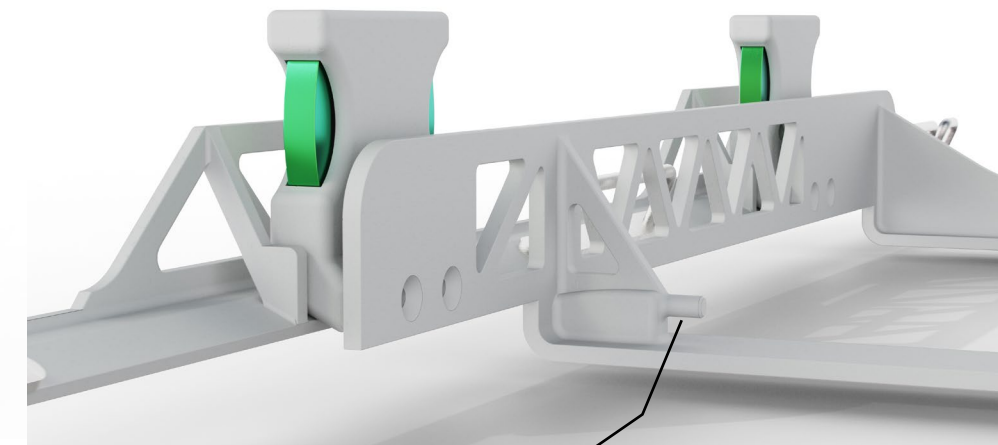

Figure 125. The mechanism is released by pressing the green pins



Figure 126. Closeup of the hook



Hinge for the backrest



*Estimated weight of fixture
2,5 kg*

6.2. Concept 2 - removable



Figure 127. Left side. The hooks are placed directly under the original brackets.

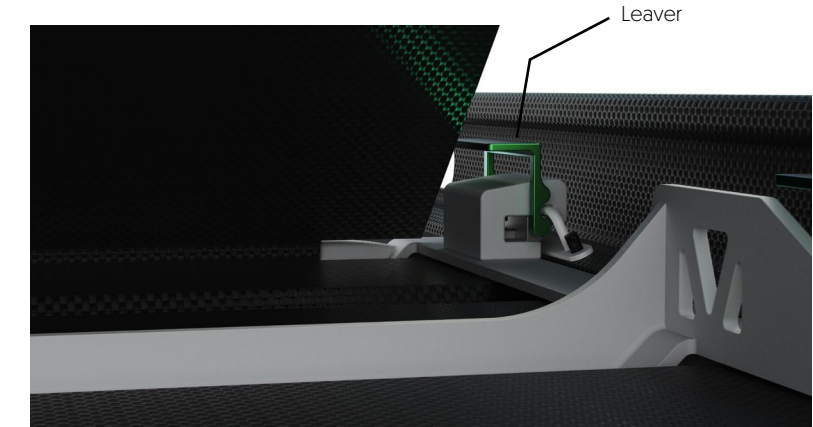
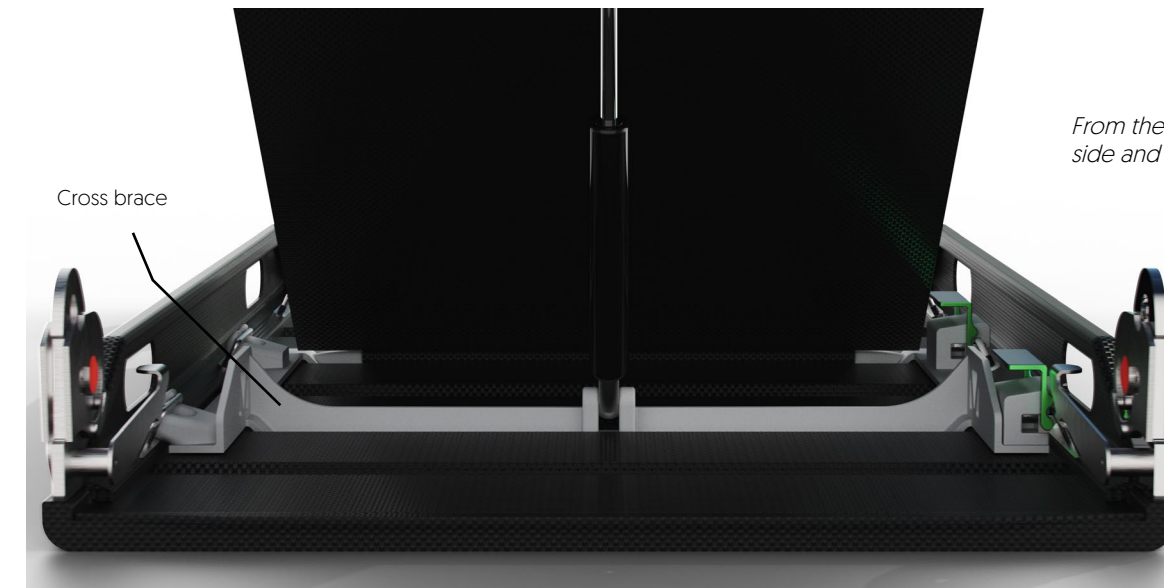

Figure 128. Right side. The latch mechanism is fastened directly on the original brackets. Pulling the green leaver releases the mechanism.



From the back. Hooks on the left side and latch on the right,

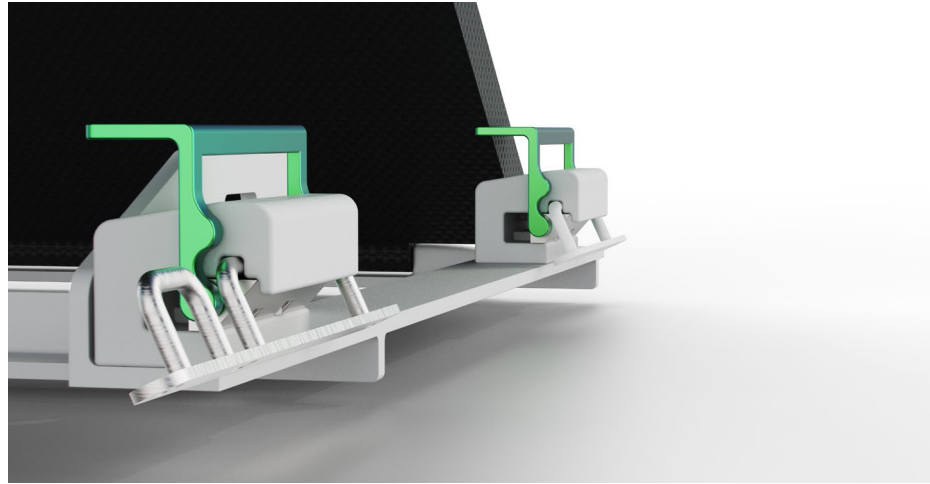

Figure 129. Right side from the back

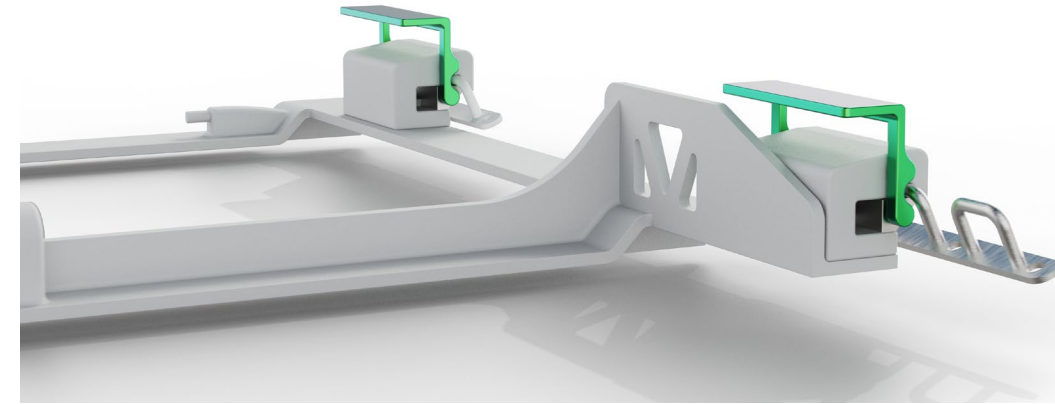

Figure 131. The fixture with cross braces, latch mechanism and adjacent brace.

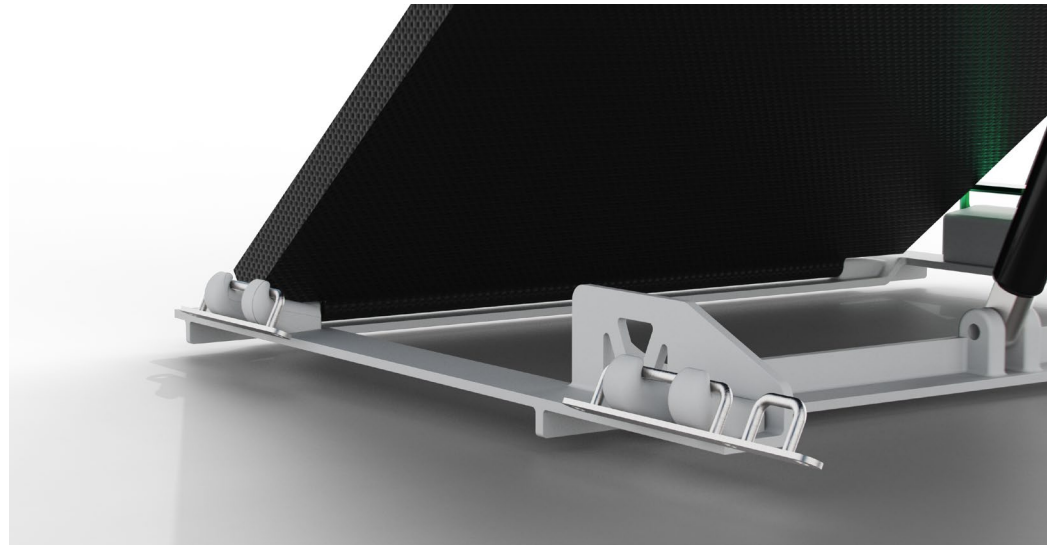
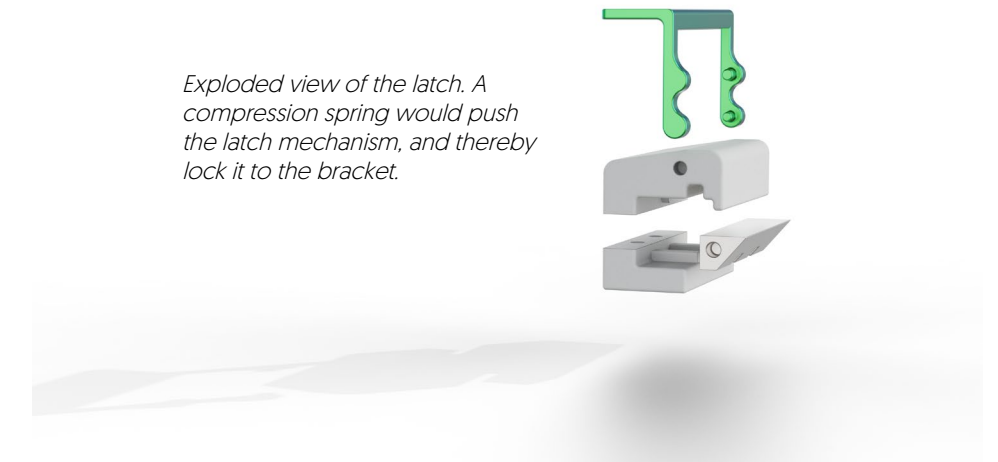

Figure 130. Left side from the back



Exploded view of the latch. A compression spring would push the latch mechanism, and thereby lock it to the bracket.

7. DISCUSSION

As the team has consisted of one product designer and one mechanical engineer it is interesting to compare the product development processes. The project began by planning the how the project would be solved individually, for later to be compared. The processes were relatively similar. A big difference however was the inclusion of users, which was clearly more prominent in the designers process plan. For the designer the users were essential both in the insight phase for understanding the problem and developing the requirement specification, and in the concept development phase for user testing and feedback. The mechanical engineer relied more on using the needs and metrics to benchmark and compare the different concepts.

The mechanical engineer had done a preliminary report for the master through the fall of 2022. This report included a requirement specification based on the insights he had so far. When the master thesis began in January 2023 it became clear what value user insights has. After interviewing relevant users several changes were made to the original requirement specification. Some of these changes has been guiding needs for the final design.

Through the project there hasn't been that many aspects that were in need of user testing. As an additional fixture for the stretcher is limited by weight to such a large extent, the requirement of "low weight" had been a huge factor when deciding concepts. In this aspect the knowledge of the mechanical engineer has been really valuable. As most concepts could be operated the same way, or had familiar mechanisms, it wasn't needed to drive to Dombås to get feedback on the concepts. A digital presentation was enough to narrow down,

and eventually decide on the final concept.

From a designers perspective the project is normally close to an end when the final concept is chosen. However, by having a mechanical engineer on the team it was possible to analyse the parts and develop a part that actually can withstand the forces it will be exposed to. This creates a more thorough process and a more functional product, and is one of the main reasons for why it was wanted to cooperate on the master thesis in the first place. The process of validating the strength of the fastening mechanism turned out to be a heavily comprehensive task. The parts had to be iterated several times in order to develop a structure that was strong enough. Through this process the structural aspect was more important than aesthetics. Making aesthetical modifications were strictly not needed as the part fulfilled all requirements. It was also not time to make even more iterations due to aesthetics, which would require new validation analysis.

It was considered to use topology optimization on some of the structural parts of the fixture, like the brace and the backrest. As the analysis show the parts could be optimized further by removing material in areas not crucial for structural integrity. This was however not done due to not knowing all the forces the fixture will be exposed to.

During the insight phase three possible solutions were presented, and it was chosen to work mid term solution. The mid term solution changed the project goal to the following:

"...develop a function to accommodate elevated backrest, as well as improve ergonomics and getting the stretcher a lot closer to be certified for permanent use."

The final concept has the lowest weight of all the concepts that has been discussed through the project, and is xxx grams less than what paramedics exclaimed was a very good solution. 5kg?

The quick release fastening mechanism makes the fixture easy to install and remove quickly.

Improving the ergonomics of the carrying handles were downprioritized as developing the fastening mechanism was higher prioritized and took more time than expected.

The lifting mechanism is familiar and is the smoothest of all the concepts. It can be locked anywhere within its range. The concept is accomodated a handle similar to the AC-stretcher which is experienced as ideal by paramedics.

The fixture is thoroughly analysed and made to withstand 2 more G's than the required 5 G's. Certification for use with the new fixture was also downprioritized as it became clear that a new certification process wouldn't be prioritized by the NAA. For the new fixture to be certified for use in the helicopter it has to withstand 20 G's. In reality this would only be achieved in a crash. Neither the paramedics or ourselves saw the point in using excessive material to make the stretcher meet a criteria that only applies in a crash. If the helicopter crashes, there are bigger problems than the fixture breaking. In addition to this, the brackets available to fasten a new fixture does not withstand more than 5? G's. This meant that the new fixture only had to withstand more than 5G's to not be the weakest link.

#	Needs	Relevance
1	Low weight	•••••
2	Easily maneuverable size	•••••
3	Easy to install and remove	•••••
4	Easy to operate when installed	•••••
5	Can achieve at least 30°	•••••
6	Can be used in multiple stretchers	•
7	Can handle high stress and vibrations	•••••
8	Can fit all patients regardless of size	•••••
9	Can be used in different temperatures	•••••
10	Can lock at a given angle	••
11	Long lifespan	•••
12	Assisted lifting	••
13	Mechanism does not move in rough terrain	•••••
14	Ergonomics	•••
15	Certification for use	•••••
16	Can be folded with the stretcher	•
17	Legal fastening of stretcher to helicopter	•
18	Better straps to secure the patient in the stretcher	N/A
19	Smooth operating. [No sudden movements]	•

Copy of table 1.

7.1. Administrative challenges on the way

Writing the master interdisciplinary has brought some challenges along the way. The faculty for Design and the faculty for mechanical Engineering operates with different dates for delivery of the master thesis. As the students are writing the master thesis together, it would be beneficial and practical to have the same delivery date. None of the people that has been contacted dur

As few, or no students has written the master thesis interdisciplinary before, it took a long time to get this application approved.

Later in the project, Høiseth got sick for a week, and got a postponement. Lilleeng however, did at first not get the same postponement because they belong to different faculties. This made no sense as they are writing the same thesis, and are just as, or even more dependent of each other as if they had been students from the same faculty. This brought a lot of uncertainty and time had to be spent on convincing the design faculty that it made sense to treat the students as they would if they were both from the same faculty. Luckily, the extension was eventually granted.

It is too bad that there have to be such administrative challenges when trying to do something that is harder in the first place. NTNU promotes interdisciplinary work a lot, and every fourth year student has a mandatory subject called Experts in Team which is all about cooperating interdisciplinary. The master thesis should be about showing off what you can achieve in a realistic situation. A situation where a product designer develops a product without any cooperation with a mechanical engineer is not common. In reality a product designer and a mechanical engineer should work together in a new product development process. With basis in these arguments, NTNU should support students wanting to write their thesis's interdisciplinary.

8. FURTHER WORK

This product presented in this thesis is a result of a thorough design phase. It is not yet ready for final production. The purpose of this is to look at the possible solutions to this problem. The thesis can serve as a foundation for further development with more time and resources available.

List of areas for further work:

- A more thorough analysis of the forces measured from a helicopter would provide a great foundation for more accurate calculations.
- A detailed mapping of the weight of a human body in elevated backrest
- An in-depth study of ideal ergonomics of an operating handle
- Validation and a complete analysis of the whole system
- Further optimization of flat bars possibly using two-dimensional topology optimization.
- A destructive test and analysis of a CFRP sandwich panel
- Fully detailing an idealized backrest

9. REFERENCES

AS, L. [Producer]. [2020]. Øvelse gjør mester. [Image] Retrieved from <https://www.facebook.com/lufttransport/posts/pfbid0348mH5BSXEZ9W43X9CcD4crtksXHaL4QDdkzt3cx66RisJ6sj2jltq3hL6dQMFbqUl>

Aye, T. B. [Producer]. [2023]. Mountain stretcher. [Image] Retrieved from <https://www.thebangoraye.com/missing-wheel-cost-mountain-rescue-team-thousands-replace/mountain-stretcher/>

BB&CO. [2020]. How to effectively use storytelling in interviews [Blog post]. Retrieved from <https://bbcostorytelling.com/blog/how-to-effectively-use-storytelling-in-interviews/>

Borgen, B. H., & Strand, Ø. M. [2022]. Utforskning av ryggheveløsninger for luftambulansens Franco Garda- redningsbåre.

Burgos, M. [Producer]. [2022]. Compact, light and easy to assemble inflatable stretcher. [Image] Retrieved from <https://www.designboom.com/design/inflatable-stretcher-yu-hsin-wu-portable-07-28-2022/>

CARE, E. [Producer]. [2023]. Pasientbag Thermo Rescue Bag. [Image] Retrieved from <https://emergency-care.no/produkt/pasientbag-thermo-rescue-bag/>

Cha, J., Kim, J., Ryu, S., & Hong, S. H. [2019]. Comparison to mechanical properties of epoxy nanocomposites reinforced by functionalized carbon nanotubes and graphene nanoplatelets. *Composites Part B: Engineering*, 162, 283-288. doi:<https://doi.org/10.1016/j.compositesb.2018.11.011>

Chawla, K. K. [2013]. *Composite Materials: Science and Engineering*: Springer New York.

CHC [Producer]. [2023]. CHC Reach Beyond. [Logo] Retrieved from <http://chcheli.com/>

Clauser, C. E., McConville, J. T., & Young, J. W. [1969]. Weight, volume, and centre of mass of segments of the human body.

DOGA. [n.d.]. Guide for designdrevet innovasjon. Retrieved from <https://doga.no/verktoy/designdrevet-innovasjon/guide-for-designdrevet-innovasjon/2/designprosessen/>

ecourses. [2023]. MECHANICS - THEORY. Retrieved from https://www.ecourses.ou.edu/cgi-bin/ebook.cgi?topic=me&chap_sec=06.1&page=theory

Engineers_edge_1. [2023]. Fastener Threaded Shear Area Equation and Calculator ISO898. Retrieved from https://www.engineersedge.com/thread_strength/thread_bolt_stress_area_iso.htm

Engineers_edge_2. [2023]. ISO 68-1 Metric Thread Profile Specifications and Equations. Retrieved from https://www.engineersedge.com/hardware/iso_681_metric_thread_14599.htm

Engineers_edge_3. [2023]. Metric Threads ISO 724. Retrieved from https://www.engineersedge.com/hardware/metric_threads_iso_724_13176.htm

Equipment, T. A. R. [Producer]. [2023]. Stretcher Rescue Trailer. [Image] Retrieved from <https://tyromont.com/en/products/produkt-detail/categories/rettungs-gebirgstrogen/products/verletztentrage-tyromont.html>

Fjellpulken [Producer]. [2023]. Fjellpulken Alpine Rescue 220 Redningspulk. [Image] Retrieved from <https://www.fjellpulken.no/butikk/rescue/fjellpulken-alpine-rescue-220-redningspulk/>

Force, T. R. N. A. [Producer]. [2023]. 330 skvadron. [Logo] Retrieved from https://no.wikipedia.org/wiki/330_skvadron

Helis [Producer]. [2023]. Eurocopter Super Puma in Helikopter Service. [Image] Retrieved from <https://www.helis.com/database/modelorg/Helikopter-Service-Super-Puma/>

Heliwing [Producer]. [2023]. Helikopter Luftambulanse AW139. [Image] Retrieved from https://heliwing.no/no/aw139_helikopter_luftambulanse

Høiseth, E. [2022]. Development of a light, strong and mobile solution to accommodate elevated backrest in extreme conditions on a Franco Garda stretcher.

Johannessen, J. [2002]. *Tekniske tabeller*. Latvia: Cappelens forlag A/S.

Kallestad, G. [Producer]. [2021]. Styrket beredskap med ny base i nord. [Image] Retrieved from <https://www.nordnorskdebatt.no/styrket-beredskap-med-ny-base-i-nord/o/5-124-109250>

Kristiansen, S. I. [Producer]. [2022]. Luftambulanse. [Logo] Retrieved from <https://sml.snl.no/luftambulanse>

Landgraff. [2023]. GASSFJÆRER. Retrieved from <https://www.landgraff.no/2015-Katalogen/2015-Kapittel10.pdf>

LINOWES, J., & [2023]. How to Calculate Fastener Minimum Thread Engagement Length. Retrieved from <https://www.omniamfg.com/mechanical/2020/10/3/how-to-calculate-fastener-minimum-thread-engagement-length>

Luftambulansen. [2022a]. About the National Air Ambulance Services of Norway. Retrieved from <https://www.luftambulanse.no/basene-vare>

Luftambulansen [Producer]. [2022b]. Basene våre. [Image] Retrieved from <https://www.luftambulanse.no/basene-vare>

Luftambulansen. [2022c]. Basene våre. Retrieved from <https://www.luftambulanse.no/basene-vare>

Luftambulansen. [2023]. Om oss. Retrieved from <https://luftambulanse.no/om-oss>

Luftambulansetjenesten. [2022]. Aktivitetsrapport 2021. Retrieved from <https://www.luftambulanse.no/aktivitetsrapporter>

Lufttransport [Producer]. [2023]. Lufttransport. [Logo] Retrieved from <https://www.lufttransport.no/>

matweb. [2023]. Aluminum 7075-T6; 7075-T651. Retrieved from <https://www.matweb.com/search/DataSheet.aspx?MatGUID=4f19a42be94546b686bbf43f79c51b7d&ckck=1>

Meber [Producer]. [2023a]. Fixed Rescue stretcher. [Image] Retrieved from <https://www.meber.it/en/products/stretchers/fixed-rescue-stretchers/fixed-rescue-stretcher-639.aspx>

Meber [Producer]. [2023b]. Toboga 16102. [Image] Retrieved from <https://www.meber.it/en/products/stretchers/toboga/toboga-16102.aspx>

Medsurge [Producer]. [2023]. API Inflatable Rescue Stretcher. [Image] Retrieved from <https://www.medsurgehealth.co.ke/product/api-inflatable-rescue-stretcher/>

Mirdehghan, S. A. [2021]. 1 - Fibrous polymeric composites. In M. Latifi [Ed.], Engineered Polymeric Fibrous Materials [pp. 1-58]: Woodhead Publishing.

NAVA [Producer]. [2023]. Exped Chair Kit. [Image] Retrieved from <https://navasport.no/exped-chair-kit-mediumwide>

Nilsen, T. V., & Larsen, T. [2016]. Konstruksjonmekanikk for bachelor. Kanalveien 51 5068 Bergen: fagbokforlaget.

Oleano. [2023]. Centre of mass. Retrieved from <https://olearno.app/center-of-mass.html>

Pedersen, B., & Kaland, T. [2023]. aluminium. In SNL.

Sankaran, K. K., & Mishra, R. S. [2017]. Chapter 4 - Aluminum Alloys. In K. K. Sankaran & R. S. Mishra [Eds.], Metallurgy and Design of Alloys with Hierarchical Microstructures [pp. 57-176]: Elsevier.

Simkus, J. [2023]. Snowball Sampling Method: Definition, Method & Examples. Retrieved from <https://www.simplypsychology.org/snowball-sampling.html>

Solidworks. [2023]. Tensile Stress Area of a Bolt. Retrieved from https://help.solidworks.com/2021/english/SolidWorks/cworks/r_Tensile_Stress_Area_Bolt.htm

Stollenwerk [Producer]. [2023]. Manual Strecher systems. [Image] Retrieved from <https://www.stollenwerk-koeln.de/en/products/details/103/>

Story, R. D., & [2014]. Design of Composite Sandwich Panels for a Formula SAE Monocoque Chassis. [masters, Oregon State University].

Support, A. a. S. [Producer]. [2023]. Medevac IIA Break-Apart Litters. [Image] Retrieved from <https://a-ss.no/produkter/medevac-board/>

Truong, G. T., Tran, H. V., & Choi, K.-K. [2019]. Tensile Behavior of Carbon Fiber-Reinforced Polymer Composites Incorporating Nanomaterials after Exposure to Elevated Temperature. *Journal of Nanomaterials*, 2019, 4139208. doi:10.1155/2019/4139208

TSL_Rescue [Producer]. [2023]. The Franco Garda. [Image] Retrieved from <https://www.tsrescue.com/en/franco-garda/>

Ulrich, K. T., Eppinger, S. D., Yang, M. C., & Ulrich, K. T. [2020]. Product design and development [Seventh edition. ed.]. New York, NY: McGraw-Hill Education.

Vera, M. [2023]. Patient Positioning: Compete Guide And Cheat Sheet for Nurses. Retrieved from <https://nurseslabs.com/patient-positioning/>

volksbolts. [2023]. Stainless Steel Basic Properties. Retrieved from <http://www.volksbolts.com/faq/basics.htm>

Wikimedia [Producer]. [2006]. CHC Helicopter Scotia Sikorsky S-92A. [Image] Retrieved from <https://www.helis.com/database/modelorg/Helikopter-Service-Super-Puma/>