

Master's thesis

NTNU
Norwegian University of Science and Technology
Faculty of Information Technology and Electrical
Engineering
Department of ICT and Natural Sciences

Anfeng Liu

Geographic Information System for Decision Support

Master's thesis in Simulation and Visualization

Supervisor: Ricardo da Silva Torres

June 2020



Norwegian University of
Science and Technology

Anfeng Liu

Geographic Information System for Decision Support

Master's thesis in Simulation and Visualization

Supervisor: Ricardo da Silva Torres

June 2020

Norwegian University of Science and Technology

Faculty of Information Technology and Electrical Engineering

Department of ICT and Natural Sciences



Norwegian University of
Science and Technology

Abstract

With the development of related technologies and tools, Geographic Information Systems (GISs) have been widely used in different fields. GIS applications have provided significant support for data analysis and visualization in some practical areas, such as urban planning, building monitoring, and search and rescue operations. In recent years, advances in Artificial Intelligence and Big Data technology have facilitated many Decision Support Systems (DSSs) to be applied in professional areas. The applications of expertise DSS have proven their stability and usability in different scenarios. The combination of GIS and DSS is considered as a trend conducive to enhancing GIS capabilities.

This work investigates the integration of GIS and DSS. A generic architecture of GIS for decision support is proposed based on the three-layer architecture commonly used for information systems. In addition, a visualization framework based on categorized data processing is proposed to guide the development of the user interface of this system.

We conduct two case studies about the usage of integration of GIS and DSS and implement two applications of GIS for decision support based on the proposed architecture and framework. We validate the proposed architecture and framework through a conducted evaluation experiment and analysis of results from a case study for Smart Building.

Acknowledgements

First, I would like to express my great gratitude to my supervisor Ricardo da Silva Torres, who has provided consistent support and valuable guidance to my work. His indispensable supervision throughout the entire process encourages me to complete this master thesis.

I would also like to thank Dr. Amin Moazami for his generous help and advice during the application implementation and evaluation. Without his valuable support and assistance, this work would have been impossible.

Besides, I am deeply grateful to the fourteen volunteers who participated in my evaluation experiment. Their active participation and selfless help made the evaluation work possible.

Preface

This document contains a master thesis of the Master of Science degree at the Simulation and Visualization program at the Norwegian University of Science and Technology (NTNU). The related research was inspired by a course project in the third semester of the master program and mainly conducted in the spring of 2020. Our investigation explores the application of Geographic Information System for decision support.

Table of Contents

Abstract	i
Acknowledgements	iii
Preface	v
Table of Contents	viii
List of Tables	ix
List of Figures	xii
Abbreviations	xiii
1 Introduction	1
1.1 Background	1
1.2 Motivating Applications	2
1.2.1 Search and Rescue Operations	2
1.2.2 Building Monitoring	3
1.3 Objectives and Contributions	4
1.4 Outline of Thesis	5
2 Background and Related Work	7
2.1 Geographic Information System	7
2.2 Visualization in SAR Operation	8
2.3 Visualization for Smart Building and Sensor Data	9
2.4 Web Mapping Libraries	10
2.4.1 Overview	10
2.4.2 LeafletJS	11
2.4.3 CesiumJS	12
2.4.4 MazeMap	13
2.5 Evaluation Framework for Visualization	13

3	Generic Architecture of GIS for Decision Support	15
3.1	System Architecture	15
3.2	Framework for Data Visualization on User Interface	17
4	Case Study A: AI-SAR System	21
4.1	Overview	21
4.2	Architecture	22
4.3	A Multi-layer Map Interface	24
4.3.1	Map Structure	24
4.3.2	Base Map Layer	24
4.3.3	Weather Map Layer	26
4.3.4	Object Map Layer	26
4.4	Implementation	28
4.4.1	Mapping Data	28
4.4.2	Environmental Data	29
4.4.3	Application Object Data	30
5	Case Study B: Smart Building	33
5.1	Overview	33
5.2	Architecture	34
5.3	Double-scale Map Interface	36
5.3.1	Map Structure	36
5.3.2	Outdoor Map	36
5.3.3	Indoor Map	40
5.3.4	Dashboard	42
5.4	Implementation	43
5.4.1	3D Outdoor Map	43
5.4.2	2D Indoor Map and Dashboard	44
6	Evaluation and Discussion	47
6.1	Evaluation	47
6.1.1	Evaluation Protocol	47
6.1.2	Profile Form and Evaluation Form	48
6.1.3	Results	51
6.2	Discussion	57
7	Conclusion and Future Work	61
7.1	Conclusion	61
7.2	Future Work	62
	Bibliography	65

List of Tables

2.1	Well-known libraries used for web mapping (Farkas, 2017).	11
6.1	Summary of judgments and preferences.	55
6.2	Summary of the most frequent suggestions provided by evaluators.	56
6.3	Different performance of participants with different knowledge about information visualization.	56
6.4	Different performance of participants with different knowledge about sensor-based data analysis.	57
6.5	The comparison from the perspective of system structure.	58
6.6	The comparison of required data in two applications.	58

List of Figures

1.1	Both accident details and suggested rescue plans are presented by GIS to support decision-making.	2
1.2	Energy usage with time series is presented on a map-based interface. . . .	3
3.1	Architecture of GIS for decision support.	16
3.2	Proposed framework for data visualization.	18
3.3	Framework for GUI in a GIS for decision support.	18
4.1	Architecture for AI-SAR system.	22
4.2	Architecture of GIS application for AI-SAR system.	23
4.3	Three map layers.	25
4.4	Base map layer.	26
4.5	A Popup box displays weather information.	26
4.6	A Popup box shows object identification.	27
4.7	Historical path of the rescue helicopter.	27
4.8	Visualization of AI analysis.	28
4.9	Process of mapping data visualization.	29
4.10	Process of environmental data visualization.	29
4.11	Process of application object data visualization.	30
5.1	Architecture of the designed Smart Building application.	34
5.2	Structure of Double-scale map.	37
5.3	Three map layers on outdoor scale.	38
5.4	Sunlight on 3D outdoor map.	38
5.5	Energy use visualization of buildings.	39
5.6	Indoor environmental quality monitoring of buildings.	39
5.7	Three map layers on indoor scale.	40
5.8	Heatmap of occupancy.	41
5.9	Warnings from IEQ analyzer.	42
5.10	Current sensor data and historical sensor data.	42
5.11	Comparison of pressure and humidity trends.	43

5.12	Process of data visualization on 3D outdoor map.	44
5.13	Process of data visualization on 2D indoor map.	45
6.1	Information on age and education of participants.	51
6.2	Familiarity with information visualization approaches and sensor-based data analysis.	52
6.3	Feedback on the GUI usability regarding Task 1.	52
6.4	Feedback on the GUI visual quality regarding Task 1.	53
6.5	Feedback on the GUI usability regarding Task 2.	53
6.6	Feedback on GUI usability regarding Task 3.	54
6.7	Feedback on GUI visual quality regarding Task 3.	54
6.8	Each map canvas has three map layers for corresponding visualization. . .	59

Abbreviations

AI	Artificial Intelligence
AR	Augmented Reality
API	Application Programming Interface
DSS	Decision Support System
GIS	Geographic Information System
GUI	Graphical User Interface
IEQ	Indoor Environmental Quality
RC	Rescue Commander
SAR	Search and Rescue
VR	Virtual Reality
UI	User Interface
WMS	Web Map Service

Introduction

In this chapter, the general background and motivation for the project are described in **Section 1.1** and **Section 1.2**. In addition, the objectives and contributions are presented in **Section 1.3**. Finally, the outline of the thesis is presented in **Section 1.4**.

1.1 Background

The Geographic Information System (GIS) has grown from a privileged technology available only to few established institutions to an all-access platform available to the public over the past half-century (Yuan, 2017). Nowadays, GIS has been widely used in different fields (Egenhofer et al., 2016; Longley et al., 2015). A kind of significant use of GIS is to help experts understand the complex and dynamic systems in their expertise to support them in making analyses and decisions (Yuan, 2017). For example, the application of GIS has achieved success in urban planning (Alhamwi et al., 2017; Kahila-Tani et al., 2016), emergency response (Šterk and Praprotnik, 2017), market research (Orford, 2017), military operations (Fleming et al., 2009), and criminal justice (Caplan et al., 2011; Chainey and Ratcliffe, 2013).

Decision support systems (DSS) are computer-based information systems designed to support complex decision making and problem solving (Arnott, 2004). Decision support systems technology and applications have evolved significantly since the early development in the 1970s (Shim et al., 2002). The development of artificial intelligence and machine learning has made decision support systems more powerful, allowing experts to benefit more from their use in professional tasks (Merkert et al., 2015; Safdar et al., 2018; Baryannis et al., 2019).

At present, GISs used for decision support are often based on human analysis. GIS still has a limited capacity to reason, induce, and deduce complex problems (Lü et al., 2019). Usually, the support from GIS for decision-making is limited to presenting processed geographic information or friendly data visualization contents so that users can make decisions based on these contents (Crossland, 2008; Omidipoor et al., 2019). Therefore, the combination of GIS and complex decision support systems is considered as one

of the promising future trends (Rikalovic et al., 2017; Lü et al., 2019).

Experts believe that one big development in the future of GIS will come at the user interface (UI) level, and it may be converged with 3D maps, indoor maps, augmented reality (AR), and virtual reality (VR).¹ Traditional GIS is often equipped with relatively monotonous expressions and interaction styles, which sometimes makes it difficult for users to understand the system due to the differences in cognitive habits and professional backgrounds of individuals. Therefore, The GIS with a more advanced and friendly user interface is regarded as another future trend (Lü et al., 2019).

We expect to investigate and explore the combination of GIS and decision support systems. On this basis, we describe an in-depth investigation into the user interface of such a combined system.

1.2 Motivating Applications

This section presents some applications related to the use of GIS for decision support, which have motivated our work.

1.2.1 Search and Rescue Operations

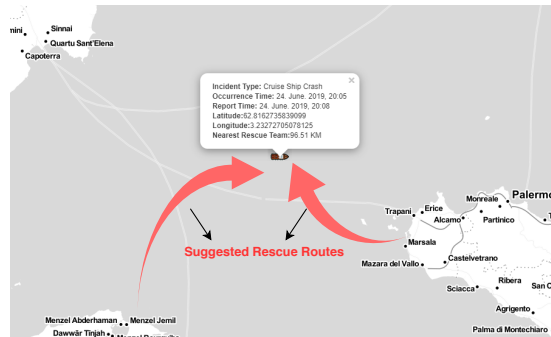

Figure 1.1: Both accident details and suggested rescue plans are presented by GIS to support decision-making.

Search and Rescue (SAR) comprise the search for, and provision of aid to, persons, ships or other craft which are in distress or imminent danger.² The response time is a crucial factor in SAR operations, which has a significant impact on victims' survival rates (Pitman et al., 2019). SAR organizations are expected to provide a quick response to the accidents with the help of visualization and analysis tools. Various kinds of GIS for decision support has been widely used in different SAR scenarios nowadays. For example,

¹<https://gis.usc.edu/blog/the-future-of-gis/> (As of June 2020).

²https://web.archive.org/web/20080803015913/http://www.casaraontario.ca/~webmaster1/Manuals/NationalSARmanual_full_english.pdf (As of May 2020).

Rossmo et al. (2019) proposed a bayesian GIS analysis method to improve the performance of SAR operations. Their research integrated search tracks and cell phone activity into an optimal probability search map through Bayes' theorem, which was displayed by a GIS to provide decision-making support. Zhou et al. (2020) implemented a GIS as the simulation and analysis tool for the maritime SAR. In their research, the developed GIS was used to validate and evaluate various designed scenarios for SAR of maritime accidents. **Fig. 1.1** presents another possible use of GIS for decision support in the ship crash SAR operations. The GIS in this figure can provide the related information about this ship crash incident and suggest proper rescue routes. Recently, the concept of AI-SAR has been proposed, which is a kind of SAR system that can benefit from Artificial Intelligence approaches. SAR operations are expected to receive more support from GIS with the introduction of Artificial Intelligence. Usually, GISs used for decision support in SAR operations require quick system response time, dynamic analysis capacities, effective graphical interface, and different information visualization approaches.

1.2.2 Building Monitoring

The applications of GIS for decision support in building monitoring are usually conducted from two perspectives. One is to monitor sets of buildings in a certain region. The relevant scenarios are often associated with city management. For example, urban sprawl has been regarded to have numerous negative effects on the environment and biodiversity, and the GIS for urban sprawl monitoring can help city managers limit this phenomenon (Durieux et al., 2008). **Fig. 1.2** shows an example of the possible use of GIS for decision support in urban management. The energy use of different living areas and working areas is displayed by GIS to help city administrators analyze the energy consumption in this city to make energy-saving plans. Similarly, noise is a significant health concern for people living in urban environments. Deng et al. (2016) proposed an improved 3D GIS for showing the impact of noise on all buildings in particular areas, which was expected to help urban managers quickly judge noise and support their management plans.



Figure 1.2: Energy usage with time series is presented on a map-based interface.

Another use of applications of GIS in building monitoring is for monitoring several or

a specific building. One usage scenario is to help building managers to obtain the indoor environmental quality in buildings through monitoring the data collected by various sensors (Hua et al., 2014). Another example is to assist architects in designing and constructing buildings by integrating GIS and Building Information Modeling (BIM) (Mignard and Nicolle, 2014). For the GIS used in building monitoring, a 3D visual interface and 3D data analysis capacities are commonly employed technologies.

1.3 Objectives and Contributions

Based on the background and motivation presented in the previous section, we define the overall goal of this thesis:

Explore a generic approach to combining GIS with the complex DSS, and validate this approach through the implementation of applications.

A set of research questions are defined below and investigated later to reach this goal of the thesis.

- **RQ1:** How to propose a generic architecture of GIS that could be compatible with complex decision support systems?
In this thesis, we investigate the proposed initiatives in the area and the current status of GIS as well as related technologies and tools. We believe that such a architecture can be proposed by considering the characteristics of GIS and DSS and modifying the basic information system structure.
- **RQ2:** How to propose a development framework for the user interface of such a system?
The presentation of information by the user interface is essentially a data visualization problem. We concentrate on the data characteristics and propose a practical framework for the graphical user interface of this GIS combined with DSS.
- **RQ3:** Is it possible to develop applications based on the proposed system architecture and user interface framework?
In this thesis, we conduct two case studies and apply the proposed architecture and framework to these cases. Case Study A concerns the development of an AI-SAR application, which is a GIS used for SAR and expected to benefit from Artificial Intelligence (AI). The other case involves an application for Smart Building, aiming to help managers monitor and maintain their supervised buildings.
- **RQ4:** Would the applications based on the proposed system architecture and the user interface framework be usable for users?
An evaluation experiment is conducted after the implementation of the application. We validate the usability of the application through this evaluation.

The main contributions of this thesis are stated below:

- We propose the generic architecture of GIS for decision support.
- We propose a development framework for the GUI of GIS for decision support.

- We implement the application for AI-SAR system based on the proposed architecture and framework.
- We implement the application for Smart Building based on the proposed architecture and framework.
- We evaluate the GUI of application Smart Building and analyze the evaluation data.

1.4 Outline of Thesis

The outline of the rest of this thesis is as follows:

- **Chapter 2 - Background and Related Work** Introduces some theoretical background and related research for the thesis.
- **Chapter 3 - Generic Architecture of GIS for Decision Support** Proposes the generic architecture for suggested GIS for decision support.
- **Chapter 4 - Case Study A: AI-SAR System** Presents an application for the AI-SAR case.
- **Chapter 5 - Case Study B: Smart Building** Presents an application for Smart Building case.
- **Chapter 6 - Evaluation and Discussion** Presents the evaluation and discusses the results.
- **Chapter 7 - Conclusion and Future Work** Concludes the thesis and discusses potential future research venues.

Background and Related Work

In this chapter, different theoretical background and research initiatives conducted in relevant fields related to our work are presented. **Section 2.1** describes the definition and development of GIS. **Section 2.2** presents the related research on visualization in SAR operation, while **Section 2.3** describes the background of smart buildings and related work of visualization for smart building and sensor data. Different libraries for web mapping are elaborated in **Section 2.4**. An evaluation framework is described in **Section 2.5**.

2.1 Geographic Information System

According to Environmental Systems Research Institute, Inc. (Esri), “a Geographic Information System (GIS) is a framework for gathering, managing, and analyzing data.” It analyzes spatial location and organizes layers of information into visualizations using maps and 3D scenes. The field of GIS started in the 1960s with the advent of computers and the concepts of quantitative and computational geography. In 1963, Roger Tomlinson developed the Canada Geographic Information System, regarded as the first computerized GIS. As many researchers contributed to this field and computing became more powerful, GIS went commercial in the 1980s.¹

The theory, technology, and organization in the field of GIS have developed very rapidly. Many different methods have been applied to GIS because of the diversity of this field. Therefore, the definition of GIS has also changed over time (Maguire, 1991). Dueker (1979), for example, defined that a “GIS is a special case of information systems where the database consists of observations on spatially distributed features, activities, or events, which are definable in space as points, lines, or areas.” Burrough (1986) considered that a “GIS is a powerful set of tools for collecting, storing, retrieving at will, transforming, and displaying spatial data from the real world.” With the growth of computer power and data storage capacity, researchers usually have been paying more attention to the visualization of GIS in nowadays. National Geographic proposed that “GIS is a computer

¹<https://www.esri.com/en-us/what-is-gis/history-of-gis> (As of June 2020).

system for capturing, storing, checking, and displaying data related to positions on earth's surface." Some developers believe that GIS is the web or mobile app that can bring in data and provide maps for their visualization and analysis.²

GIS allows organizations to organize and share complex information in ways that users can easily understand. It has become an indispensable tool in urban planning, emergency planning, disaster response, resource management, market research, military operations, and many other fields (Chang, 2016). With the development of open-source mapping libraries and web-based tools, the combination of GIS and web technology has brought an immense evolution to this field. Comparing to traditional desktop GIS softwares, which are usually costly and requires extensive training, web-based GIS provides a cost-saving solution (Mathiyalagan et al., 2005). Besides, Web-based GIS can greatly help geoscientists to speed up processes and work remotely; it also addresses some of the primary challenges in geosciences evaluations (Alesheikh et al., 2002). Recently, web-based GIS has been used by more and more researchers and developers, and the sector of web-based GIS and distributed GIS services are growing exponentially (Mathiyalagan et al., 2005).

GIS supporting 3D data analysis has also captured the attention of researchers in recent years. Ferreira et al. (2015) proposed a 3D framework to support decision-making in urban development, which provided the visual interface in 2D and 3D perspectives and supported visualization of both 2D and 3D data sets. Similarly, Doraiswamy et al. (2018) described that existing GIS typically worked in 2D while the data and many phenomena related to urban planning are inherently 3D. Their research investigated the spatiotemporal urban-data analysis with a designed tool supporting data exploration in 3D and 3D complex analysis.

2.2 Visualization in SAR Operation

During SAR operations, visualization of relevant information is necessary for Rescue Commanders (RC) to analyze complex situations and then make proper decisions. Geographic Information System (GIS) has proven its advantage in information visualization and management in public emergency treatment (Yang et al., 2006). Therefore, GIS is widely used in SAR operations to help rescuers obtain accurate spatial and geographic information.

Usually, the Geographic Information System applicable to search and rescue is more complex (Ferguson, 2008). They need to cover multiple types of information and have corresponding interaction functions. For example, if there is a vessel accident, at the moment of receiving the alarm to the situation, the GIS must be able to display the attributes of the target vessel and the exact location of the accident according to the that vessel's ID, as well as display the temperature, wind speed, or other weather information of the accident location and its surrounding area to help RC judge the situation and plan a suitable rescue operation (Siljander et al., 2015). After the rescue operation starts, the system must support monitoring tasks, so that RC may become aware of the real-time status of the accident situation and the status of the rescue team (e.g., helicopter or rescue vessel).

²<https://www.geospatialworld.net/blogs/what-is-gis-definition-changed> (As of June 2020).

Due to the complexity of the visualization in different SAR operations, researchers often use various GIS applications according to the characteristics of SAR operations to highlight critical information. Aronica et al. (2010) presented an agent-based system for maritime SAR operations, where they developed a GIS based on the open source GIS platform “OpenMap.” This GIS application provides a user interface to easily visualize geographical coordinates on a geographic map, which is very vital in maritime SAR operations. Also aimed at maritime SAR, Liao and Maofeng (2010) developed SARGIS, which supports not only the analysis of geographic information, vessel movements, and ocean environment data on its Graphical User Interface (GUI), but also the visualization of oil spill simulations created to improve knowledge for dealing with oil spill pollution. Similarly, there are many kinds of research for urban SAR operations. For example, Google Earth is used as a 3D visualization tool in research about Geospatial Multi-agent System for Urban SAR (Gaber et al., 2011). Bock et al. (2014) proposed a visualization system in urban SAR operations, where the system can create interactive 3D rendering and analysis of access paths. For the SAR operations with the introduction of unmanned search and robotic tools, the Command, Control and Intelligence (C2I) System is described by Govindaraj et al. (2013). Their system supports the visualization of geographical data as well as sensor data (e.g., 3D laser scans, GPS) from rescue robots.

2.3 Visualization for Smart Building and Sensor Data

The smart buildings are essential elements for building a smart city infrastructure. Autonomous smart buildings are expected to provide a convenient environment for the residents while reducing energy consumption and operational costs through integrated technologies (Eini et al., 2019). In the second half of the 1970s, the term smart building referred to a building built with the concept of energy efficiency. A building that could be controlled by PC is treated as a smart building in the 1980s. Now, the smart building concept is often associated with the support of managing and controlling energy sources, appliances, and energy consumption, using communication technology (Morvaj et al., 2011).

The availability of data of buildings has attracted the attention of researchers. These data are often collected by various types of sensors distributed inside or outside the building. In the past few years, research on visualization of smart buildings focused only on visualizing sensor data in smart buildings. Ludwigsdorff et al. (2016) designed and developed an application for indoor environmental quality in smart buildings. This application’s primary function was to visualize the indoor environmental state based on the data measured by sensors. Eini et al. (2019) designed and implemented a testbed for a smart building, and analyzed the collected sensor data from this testbed to study smart buildings. Plageras et al. (2018) studied the collection, processing, and analysis of sensor data in smart buildings. In their research, they proposed that the integration of Internet of Things (IoT), Big Data, Cloud Computing, and Wireless Sensor Networks could support the implementation of efficient solutions for smart cities. Bashir and Gill (2016) presented an IoT Big Data Analytics framework for the storage and analysis of real-time data generated from sensors deployed inside the smart building. Huang and Mao (2017) proposed a solution to estimate room occupancy in smart buildings, using visualization and data analysis on the top of a hybrid wireless sensor network. Similarly, Schwee et al. (2019) described

research on accurate estimates of occupant counts and environmental quality based on the visualization and analysis of heterogeneous sensor data.

GIS is a very important visualization and analysis tool in the study of smart cities. A large number of studies have proved the value of GIS in the field of smart cities (Naidu, 2018). Recently, the combination of GIS and smart building has become a new trend. For example, Yamamura et al. (2017) conducted an assessment of urban energy performance through the integration of GIS and Building Information Modeling.

2.4 Web Mapping Libraries

The development of web mapping and Web-GIS technology is the recent trend of geographic informatics. Traditional geographic information systems were usually confined to specialized software on desktop PCs and could not be easily shared. A web map can be reached by anyone from any device that has a browser and internet connection (Dorman, 2020).

2.4.1 Overview

In recent years, several general Web-based GIS frameworks and libraries have appeared in both open-source and commercial fields. The characteristics of open-source and commercial libraries are shown below:³

- Commercial Libraries/Proprietary Libraries (e.g., Google Maps, Esri ArcGIS, Bing Maps):
 - They are easy for user to use.
 - They are usually maintained well.
 - A lot of them are not free.
- Open-source Libraries (e.g., LeafletJS, Mapbox GL, OpenLayers, CesiumJS):
 - They are free to use.
 - Users can use them with less limitations.
 - They usually have better transparency and extensibility.

The Google Maps Introduced in 2005 revolutionized online mapping service applications. It provides a robust set of components and services for developers to integrate into their app. Google Maps JavaScript API was the most commonly used Maps API for online mapping (Peterson, 2012). In the past, researchers usually used the Google Maps API in their research (Hu and Dai, 2013). Nevertheless, many powerful open-source libraries have arisen and proved advantages from some aspects recently. Moreover, Google changed its pricing model for maps in 2018, requiring an API key and billing account to begin development with Google Maps, which means users were not free to use any longer. Unlike the early domination of Google Map JS API, researchers today have more choices for their research on web mapping.

³<https://www.sitepen.com/blog/how-to-pick-a-web-mapping-library-for-your-app/> (As of June 2020).

Farkas (2017) believed that opposed to the slow reaction from the open-source segment of geoinformatics to proprietary desktop solutions (e.g., SYMAP or ARC/INFO), the field of web-based GIS was quickly dominated by open-source projects. He listed well-known libraries used for web mapping (**Table 2.1**) and executed a competitive analysis for open-source libraries. In his conclusion, the OpenLayers libraries were the best in the average score of each standard, the engine of CesiumJS was the best for rendering, and the LeafletJS was notable for its lightweight nature and mild learning curve. If 3D support is a hard criterion, CesiumJS could be more comfortable to extend, and LeafletJS could also be considered because of its third-party extensions. However, OpenLayers was incapable of creating 3D visualizations.

Table 2.1: Well-known libraries used for web mapping (Farkas, 2017).

Name	License	Classification	Dependency
ArcGIS API for JavaScript	Commercial	Proprietary	N/A
Bing Maps AJAX Control	Commercial	Proprietary	N/A
CartoDB.js	BSD 3-Clause	Specific purpose	Leaflet
CesiumJS	Apache 2.0	Candidate	N/A
Google Maps JavaScript API	Commercial	Proprietary	N/A
HERE Maps API for JavaScript	Commercial	Proprietary	N/A
ka-Map	MIT	Abandoned	N/A
Kartograph	GNU LGPL	Abandoned	Raphael
Leaflet	BSD 2-Clause	Candidate	N/A
Mapbox JS	BSD 3-Clause	Specific purpose	Leaflet
Mapbox GL JS	BSD 3-Clause	Specific purpose	N/A
MapQuest JavaScript Maps API	Commercial	Proprietary	N/A
Modest Maps	BSD	Abandoned	N/A
NASA Web World Wind	NOSA	Candidate	N/A
OpenLayers 2	BSD 2-Clause	Candidate	N/A
OpenLayers 3	BSD 2-Clause	Candidate	N/A
OpenStreetMap iD	ISC	Specific purpose	D3
Polymaps	BSD 3-Clause	Abandoned	N/A
Processing.js	MIT	Vector graphics	N/A
Raphael	MIT	Vector graphics	N/A

The web mapping libraries mainly involved in this thesis are LeafletJS, CesiumJS, and the recently proposed library MazeMap JS.

2.4.2 LeafletJS

LeafletJS is an open-source Javascript web mapping library developed by Vladimir Agafonkin and released in 2011. It has a tiny JavaScript code footprint of only 38Kb and most of the mapping features that developers require. LeafletJS can work on almost all the existing desktop and mobile platforms (Neene and Kabemba, 2017). LeafletJS is scalable

through a strong plugin ecosystem, which provides strong additional feature sets, making LeafletJS as functional as other mapping libraries. Due to its extremely lightweight, robustness, and scalability, many commercial companies (e.g., Microsoft, Facebook, Pinterest, FourSquare, The Washington Post, GitHub) use LeafletJS in their products (Gaikwad et al., 2018).

Recently, LeafletJS has been favored by researchers because of its simplicity and professional performance (Edler and Vetter, 2019). For example, Lu et al. (2017) developed a visualization tool for air quality monitoring on an interactive web map created by LeafletJS. Teslya (2014) implemented a free web mapping service for the mobile tourist guide based on the use of LeafletJS. Edler and Vetter (2019) created an individual audio-visual web mapping application based on LeafletJS, which presented that LeafletJS could support a straightforward integration of multimedia content. Koyuncu and Özdemir (2016) introduced a method for map geofencing based on real-time localization, in which they not only utilized LeafletJS to generate the map, but also benefited from various Leaflet plugins (e.g., Leaflet Draw for drawing and erasing shapes, Leaflet Fullscreen for fullscreen display, Leaflet Realtime for GPS display, Leaflet Pip for judging a position).

LeafletJS is also used in the field of teaching. Roth et al. (2014) conducted an in-depth and detailed competitive analysis study on existing web mapping technologies and evaluated them with the help of 21 participants. They pointed out that participants had more positive emotional experience from using LeafletJS, and then decided to use LeafletJS as the base JavaScript library for the advanced course, “Interactive Cartography and Geovisualization” at the University of Wisconsin-Madison.

2.4.3 CesiumJS

CesiumJS is an open source JavaScript library for creating world-class 3D globes and maps with the best possible performance, precision, visual quality, and ease of use.⁴ HTML5 and Web Graphics Library (WebGL) are the core of CesiumJS for hardware acceleration, which facilitates high-performance graphics and visualization. It also provides cross-platform and cross-browser functionalities without the support from other software (He et al., 2016). CesiumJS is plugin-free and can load all sorts of geo-information, including Shape Files, GeoJSON, Imagery, elevation data, and 3D and 2D vector data like 3D models (Gutbell et al., 2018).

Researchers often use CesiumJS as their tool for studying web 3D mapping and spatial-temporal visualization. He et al. (2016) developed a 3D GIS for power network based on CesiumJS, which aimed to assist power management staff in inspection and maintenance. Di Paolantonio et al. (2015) implemented the 3D virtual representation of drones’ flights through CesiumJS. Tsai et al. (2016) studied the performance of CesiumJS on 3D mapping and compared it with Google Earth Enterprise. Kang et al. (2018) researched the visualization and analysis of spatial temporal data with the help of CesiumJS.

⁴<https://cesium.com/cesiumjs/> (As of June 2020).

2.4.4 MazeMap

MazeMap is a platform for indoor maps and wayfinding. It started as an indoor/outdoor wayfinding application (called CampusGuide earlier) offered by NTNU and Wireless Trondheim, used for the main Gløshaugen campus of NTNU (Biczok et al., 2014). With development since the fall of 2011, Mazemap now provides not only a massive set of indoor map collections (e.g., universities, hospitals, venues, and hotels), but also different solutions to the public (e.g., indoor positioning, meeting room visualization, data export).

MazeMap has released the Mazemap JavaScript API for developers to use Mazemap maps and data. The MazeMap JavaScript API was built on top of the LeafletJS, and some objects used in MazeMap JavaScript API inherit from Mapbox GL JS. Compared to LeafletJS and CesiumJS, MazeMap JS is not such popular. However, its simplicity for handling indoor mapping contributes to its adoption in several applications.

2.5 Evaluation Framework for Visualization

At present, there is a lack of a consistent widely-used framework for the evaluation of visualization methods. Usually, the particular evaluation methodology is used for each visualization research work (Pinto-Cáceres et al., 2011). Previous researchers have proposed the evaluation framework and apply it to their research. A framework known as DECIDE has been adopted to guide many evaluations (Preece et al., 2002). This framework contains six procedures for evaluation:

- **Determine the goals.** The first step of an evaluation is to define the high-level goals. The determined goals influence the evaluation approach and guide this evaluation.
- **Explore the questions.** To achieve the goals, questions must be defined to obtain the evaluators' opinions.
- **Choose the evaluation paradigm and techniques.** After the goals and main questions are determined, the evaluation paradigm and techniques need to be chosen according to the actual situation of evaluation.
- **Identify the practical issues.** In the next step, the practical issues such as users, equipment, materials, schedules, and budgets involved in the evaluation should be identified.
- **Decide how to deal with the ethical issues.** Ethical issues should also be considered before evaluation experiment. For example, people's privacy should be protected. Personal records like health, employment, and financial status should be confidential unless they give permission.
- **Evaluate, interpret, and present the data.** The final step is to analyze everything obtained from this evaluation.

Some researchers have made successful evaluations based on this framework. For example, Pinto-Cáceres et al. (2015) evaluated a framework for interactive search in Image

Retrieval Systems, which was guided by DECIDE and provided very positive results. Kantosalo et al. (2015) adopted the DECIDE framework and conducted a human-computer co-creativity system evaluation for designed Poetry Machine. In later chapters, we will follow the DECIDE framework to evaluate a GUI of GIS application based on user judgement.

Generic Architecture of GIS for Decision Support

In this chapter, the generic architecture of GIS for decision support is proposed. We describe this proposed architecture and the concepts behind it in **Section 3.1**. Further, we introduce the framework for data visualization and development of GUI on the Presentation Layer of this system in **Section 3.2**.

3.1 System Architecture

As we mentioned before, the main objective of this thesis is to explore the structure of the GIS for decision support and apply this system in two usage cases. In this section, the fundamental architecture of this system is introduced, then we describe each component of this system and explain the benefit of this architecture.

Fig. 3.1 shows our proposed architecture of GIS for decision support. It is based on the well-known three-layer architecture, which is commonly used for information systems with user interface (Larman, 2005). Considering the application for GIS and the expectation to provide users with decision-making support, we suggest this architecture on top of the classic three-layer architecture. Our proposed system includes three layers and one subsystem. A brief explanation for these components is provided below.

- **Presentation Layer:** Presentation Layer is where the system presents its capabilities. The Presentation Layer is the frontest layer of a system, which is designed to interact with users. It involves the user interface (UI) that users could access by the web browser or pre-downloaded application.
- **Control Layer:** Control Layer is where the system governs the process and drives the capabilities. It comprises the performing of the commands, coordination for different components, and processing of data.

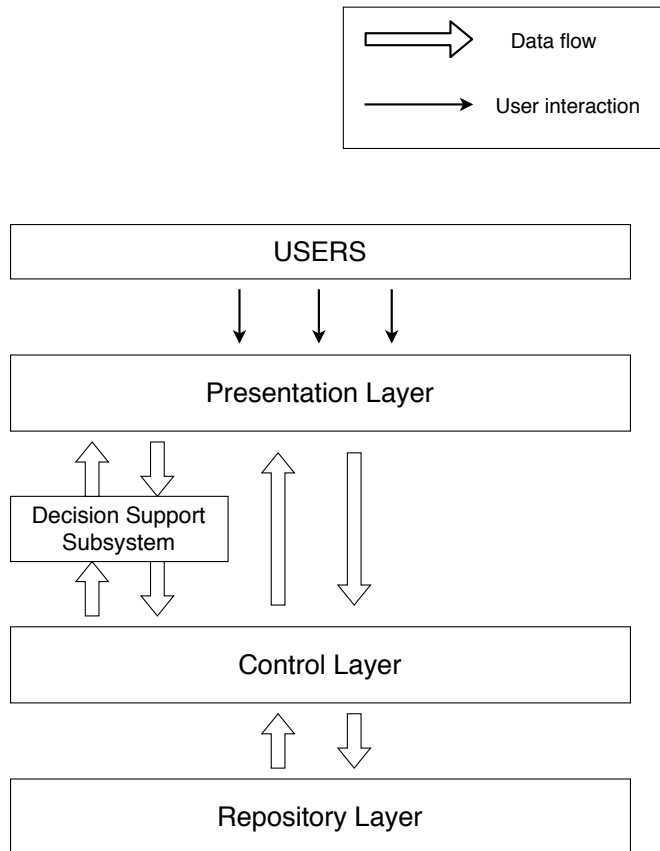

Figure 3.1: Architecture of GIS for decision support.

- **Repository Layer:** Repository Layer is where the system stores application data. The data could be retrieved from local or online repositories and file storage system.
- **Decision Support Subsystem:** It is an extension of decision support for this system. As a subsystem, this component is independent of the other three layers. It should be able to retrieve data from other layers and output results. The decision Support Subsystem could be a simple extension that contains some functional logic for making decision and evaluation, or an artificial intelligence system for one application.

Since the proposed structure is based on the classic three-layer architecture, it inherits the advantages of such architecture:

- Because each layer is independent of each other, the modification or testing of each layer will not affect the normal functions of other layers, which facilitates the development and future maintenance.

- Separating the system into multiple layers makes it possible to scale one particular layer at any time according to new requirements, which can improve the performance of system.
- The logic is more precise during the development of the system, which makes it more convenient to specify the plan of development. It allows each part of development teams to focus on the areas of their expertise.

In this architecture, the element of decision support is set up as a subsystem independent of the remaining three layers, which gives the decision support better extensibility, maintenance, and flexibility. As an independent component of the system, the Decision Support Subsystem essentially has the advantages as mentioned above. The modification and replacement of the Decision Support Subsystem will not affect the remaining modules, so the necessary capabilities of the system as GIS can still be guaranteed. From the perspective of application, executing the Decision Support Subsystem separately from the Control Layer can improve the function of decision support for users. Decision Support Subsystem is connected to the rest of the system only through the data flow. This data-oriented structure allows the Decision Support Subsystem to have higher freedom, which gives application more usage possibility, and better efficiency in utilization.

3.2 Framework for Data Visualization on User Interface

The Presentation Layer is the carrier of the UI and the window where the system expresses functionality. It determines if a system is usable by users. In this thesis, we carry out a lot of research around this layer. An essential function of the UI of GIS is to display information to users through data visualization. Therefore, based on the data-oriented principle, we divide the data to be visualized into three categories:

- **Mapping data:** Mapping data represents all the data that the Map Rendering Engine uses to construct the underlying map.
- **Environmental data:** Environmental data refers to environmental information in scenes related to targets. The UI uses it to represent the environment in which the objects are located.
- **Application object data:** Application object data is the data regarding objects that the user cares about in the application.

If we take a traffic monitoring GIS with a map-based GUI as an example, the mapping data refers to the traffic map (e.g., the layout of streets, distribution of crossroads). The data of the traffic lights can be regarded as the environmental data, and the vehicle information (e.g., speed, location) is the application object data in this case.

Fig. 3.2 shows the basic framework for data visualization on GUI. We assign three modules to visualize the data of three categories, respectively. By classifying the data obtained from the Control layer and visualizing them by different categories, the system could provide a clear graphical interface and make the implementation of application more manageable.

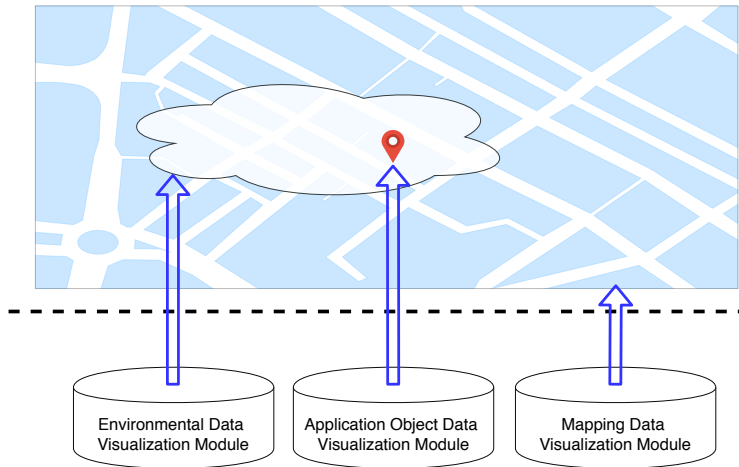

Figure 3.2: Proposed framework for data visualization.

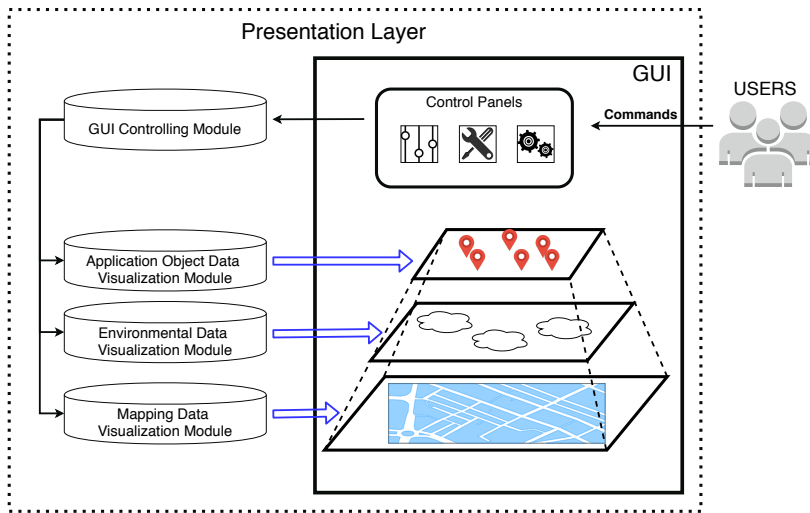

Figure 3.3: Framework for GUI in a GIS for decision support.

Since the GUI needs to provide the function of interacting with the user, in addition to data visualization, it should also have a module that receives and perform instructions from users. On the top of framework for data visualization, we extend our framework to the Presentation Layer. **Fig. 3.3** shows the framework for GUI on the Presentation Layer. Excluding the visualization module, there is also a GUI Controlling Module on the

Presentation layer, which is in charge of coordinating the visualization module and obtaining users' commands. GUI has some control panels that can receive instructions from users. These instructions will be translated into logical commands by the control panel and passed to GUI Controlling Module. GUI Controlling Module will send commands to the visualization modules after it executes the logical commands. Then three visualization modules would adjust the data visualization on GUI as users required.

Case Study A: AI-SAR System

This chapter will start with an overview of AI-SAR system in **Section 4.1**, where the structure, standard, and some characteristics of the AI-SAR system are described. Then a GIS application based on the proposed GIS architecture is presented. It includes the illustration of the architecture in **Section 4.2**, the description of the Graphical User Interface (GUI) in **Section 4.3**, and presentation of implementation aspects related to the design and development of this application in **Section 4.4**.

4.1 Overview

Normally, after receiving relevant alarms, Search and Rescue organizations or institutions will quickly act in the SAR center. Rescue Commanders (RCs) will analyze the situation, plan actions, and organize rescue. At present, analyzing, planning, and organizing SAR missions are based on RC's professional training and past rescue experience. For the existing solution, the efficiency of the Search and Rescue is limited by the personal ability of the RC, and the ability of reflection on missions is limited (Varlamis et al., 2018). Artificial intelligence is expected to be an extension of human capabilities. When in the face of an emergency, if the analysis and decision of RC can be assisted by artificial intelligence, it is likely to improve the efficiency and success of missions significantly, thereby protecting the personal and property safety to a greater extent (Bakhshipour et al., 2017). Therefore, AI-SAR, as a new concept, is expected to help the RC optimize SAR missions.

Fig. 4.1 shows the proposed workflow of SAR operations with the help of a GIS application with AI support. The top part in this figure is the standard internationally agreed SAR stadiums (also called IAMSAR standard), and the bottom part is a GIS that can benefit from the decision support system (e.g., new Knowledge System, AI support). Throughout the whole SAR operation, the RCs are expected to have frequent communications with the GIS and obtain feedback for supporting decision-making. Therefore, we need a GIS that can be in charge of both the user interface and information analysis.

As mentioned in **Section 2.2**, GIS applications for SAR are relatively complex. Compared with standard SAR systems, due to the introduction of AI, GIS applications for

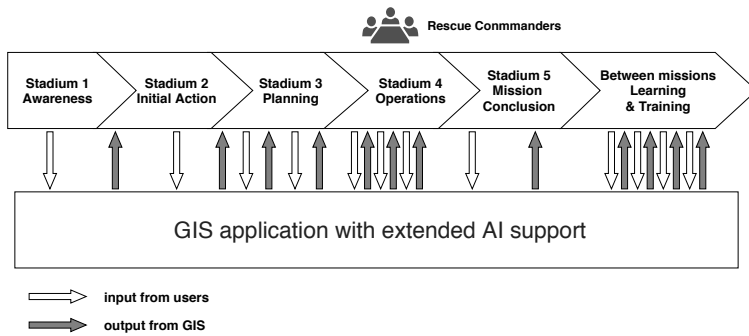

Figure 4.1: Architecture for AI-SAR system.

AI-SAR systems are expected to be complex. It must not only include all functions of existing GIS for SAR, but also can process the analysis data transmitted from AI and display it to RC instantly. For example, when the SAR center loses the signal of the wrecked ship and cannot obtain its current position, the AI subsystem is expected to calculate the predicted location or route in its geographic model based on the position, speed, direction, and weather information from the last report. This requires that the GIS can not only obtain and display the analysis transmitted by AI, but also be able to transmit the required data to AI in time. In this context, an application based on the proposed architecture is developed for AI-SAR system.

4.2 Architecture

In this section, the architecture of this GIS application for AI-SAR system will be given. It is based on the basic architecture of GIS for decision support and has been optimized according to the requirements of the target system.

Fig. 4.2 presents the structure of our GIS application, which consists of three major layers and one support subsystem: Repository Layer, Control Layer, Presentation Layer, and AI System. The Control Layer is in charge of controlling and coordinating. It classifies and integrates the data obtained from the Repository Layer, and then sends this information to the Presentation Layer. Moreover, the Control Layer may also need to deliver feedback from the Presentation Layer to the Repository Layer. The Repository Layer is where the system obtains related information (e.g., spatial data, weather data), which may be stored locally or available in public repository. The Presentation Layer is a user-oriented layer. This layer presents the integrated information to the users through a clear and friendly user interface, and receives the feedback or instructions from users.

The AI System is expected to be an independent subsystem of this GIS. Since this GIS is expected to benefit from AI, it is indispensable for GIS to obtain the information transmitted from AI System quickly and accurately, and a large amount of information from the GIS will be sent to AI for real-time analysis.

The Repository Layer mainly contains data that needs to be presented to the user. Based on the requirements for this GIS, these data need to include not only geospatial

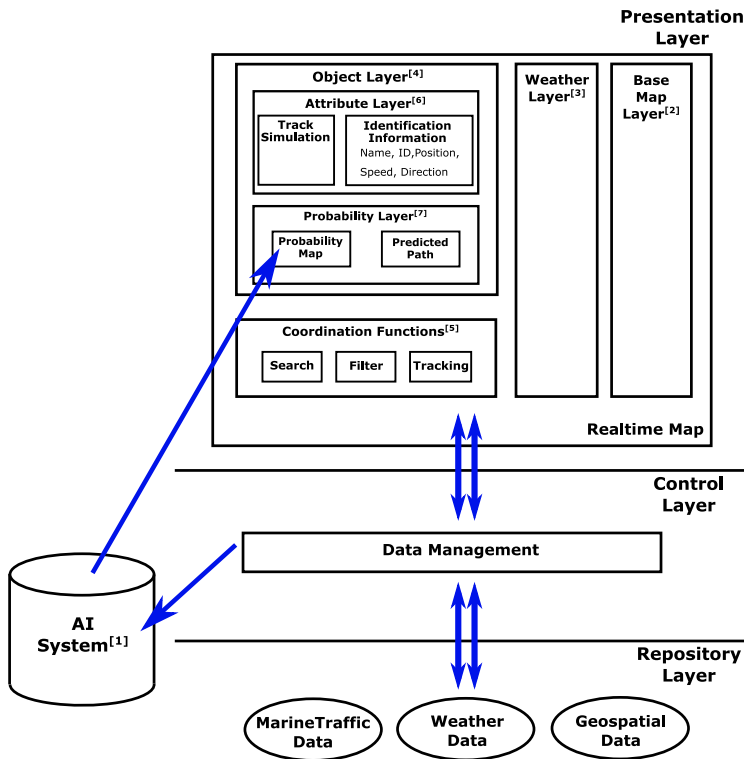

Figure 4.2: Architecture of GIS application for AI-SAR system.

data, but also weather and traffic data.

The Control Layer is responsible for filtering and sorting the data obtained from the Repository Layer and distribute it to the corresponding modules in this system. It also forwards feedback from users to the Repository Layer.

The main component of the Presentation Layer is a real-time map interface, which can also be divided into several layers. The first and most basic one is the Base Map Layer, which is the layer that contains basic geographic information like terrain information, road information, and other static information. The weather information is dynamic, such as wind, ocean current, rain or snow. This information is included in the Weather Layer and presented to the users. The most complex part of this real-time map is the Object Layer. The Presentation Layer obtains the classified marine traffic data from the Control Layer. These different marine objects belong to different classes (e.g., harbor, vessel) and are displayed on the map using different identifiers. The Attribute Layer is used to present the attributes of each object. It includes identification information, such as ID, current position, which is directly derived from the Marine Traffic database, and also the information used for operation simulations. The Probability Layer is another part of the Object Layer, where the map presents probability analysis (or hypothesis) obtained from

the AI System. AI will give hypothesis and predictions after receiving the current target object's position, speed, direction as well as local weather information. This analysis from AI will be presented by the Probability Layer as probability map or predicted path on the Presentation Layer. The Coordination Functions are connected with the controlling module, which can help the users to locate an object or one class of objects quickly and conveniently by using searching, filtering, or tracking.

4.3 A Multi-layer Map Interface

In this section, we will present the user interface for this GIS application, which we describe as a real-time map on the Presentation Layer in the previous section, and display how to visualize different types of data through a multi-layer map interface.

The web-based GUI is implemented by JavaScript and built on top of the LeafletJS library. For the base map, we use the Static Tiles application programming interface (API) to get map data from an open-source map and obtain nautical map data by Web Map Service (WMS) from the online database of the Norwegian Mapping and Cadastre Authority.

4.3.1 Map Structure

We suppose that Rescue Commanders need to use this application to obtain search and rescue information. After running the application, they will see a 2D map with a lot of information, centered on the coast of western Norway. On the ocean, there are signs such as depth, fairway, and lighthouse range. They can see some ship, harbour, or helicopter icons on the map, and click on them to see detailed information about the object of interest. RC can also observe the cloud cover or wind speed through the button box in the upper right corner of the map, or click on a specific location to get the temperature, pressure, humidity and other weather information at that location.

From the perspective of the Presentation Layer, this 2D map comprises three kinds of map layers, as shown in **Fig. 4.3**:

- Base map layer: This layer only covers the most basic information of the map. The description for this layer is detailed in **Section 4.3.2**.
- Weather map layer: This layer contains all environmental information for this Geographic Information System (e.g., weather, temperature), which is detailed in **Section 4.3.3**.
- Object map layer: A map layer is particularly used to present information of objects and the analysis from the AI System. The implementation of that AI System is not covered in this study, so **Section 4.3.4** would only illustrate how this 2D map visualizes AI analysis.

4.3.2 Base Map Layer

The base map layer is the bottom layer in this map, which includes the fundamental geographic information. This layer is mainly implemented by map tiles. Those tile images are

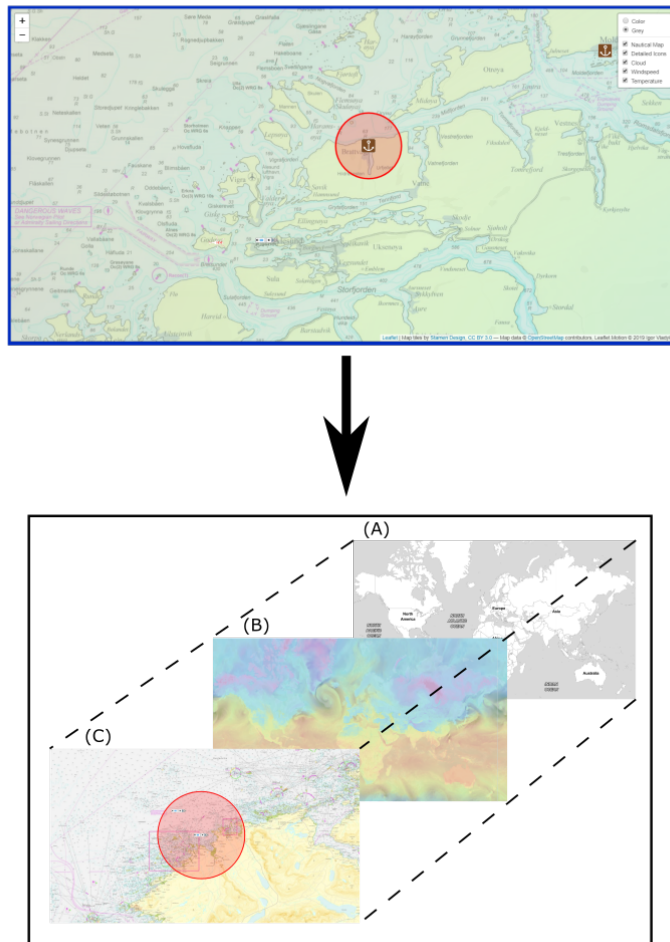

Figure 4.3: Three map layers.

mostly static, so this layer is usually consistent during the entire application run. **Fig. 4.4** shows an example of a screenshot of this application with the base map layer only. We can see that the map information displayed on this layer usually does not change over time, such as the depth contour of the ocean, the location of airports or harbours, the marine traffic fairway for ships, and areas where there are often dangerous waves.

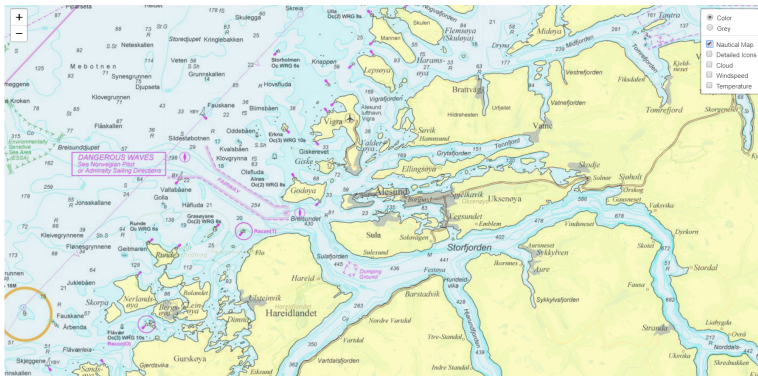

Figure 4.4: Base map layer.

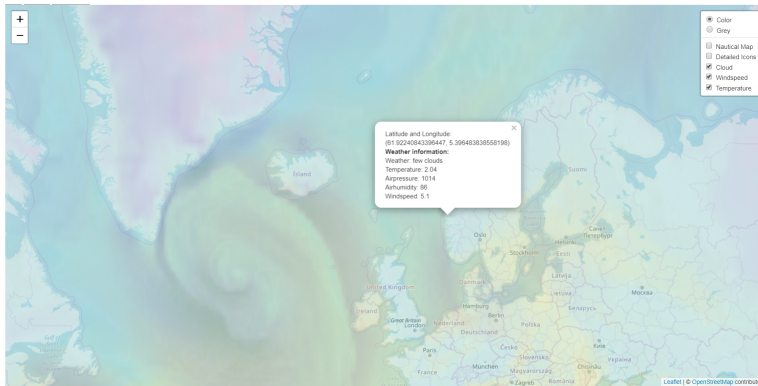

Figure 4.5: A Popup box displays weather information.

4.3.3 Weather Map Layer

The Weather map layer concerns the part of the Weather Layer for the structure described in Section 4.2. This layer contains more complex map content, such as the wind speed at a particular location, or the cloud map in one area. This content is often dynamic or semi-dynamic, so this layer needs to receive data from the data management component continuously. For example, Fig. 4.5 presents an example showing the weather information for a clicked position on the map. The application obtains the latitude and longitude of the location, and then sends a request to the server of a weather information system. After compiling the weather data received from the server, the application will display it to the RC on this layer.

4.3.4 Object Map Layer

The Object map layer is especially used by the map to show the data related to objects users care about, as well as the results of AI analysis. This layer is expected to have more

frequent communication with the data management component and the AI system.



Figure 4.6: A Popup box shows object identification.

Fig. 4.6 shows an example of a screenshot from this application showing vessel information. Suppose the RCs want to obtain the detailed information of a vessel, they can find their target through the filter or search function, click on the target's icon, and a box containing the target's detailed information will pop up on object map layer. To obtain this information, the Control Layer sends a request to the Repository Layer through the data management component. After the data management obtains detailed information of this vessel from the Repository layer, it will forward this information to the Presentation Layer, and then the 2D map will display what the RC need.

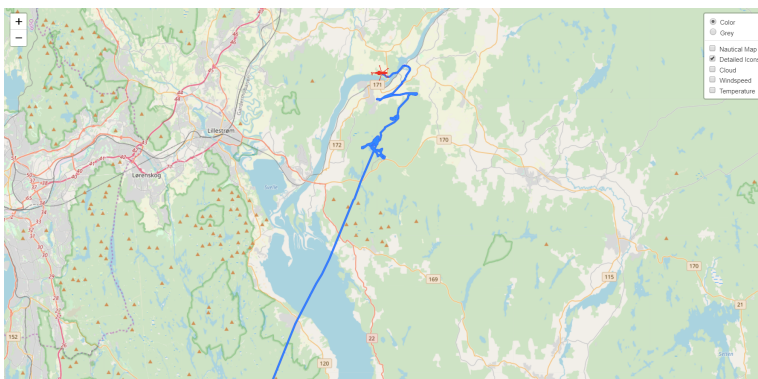

Figure 4.7: Historical path of the rescue helicopter.

Path tracking is used in situations in which the RC wants to analyze the current status of an object for its previous track or to reflect on the plan of action (Ulmke and Koch, 2006). **Fig. 4.7** shows an example of the simulation of a rescue helicopter's track, where the blue line shows the historical path of the rescue helicopter. The system imports the GPS records from the action log of the rescue helicopter from the Repository layer to the Presentation Layer and then displays it to the RC by the map.

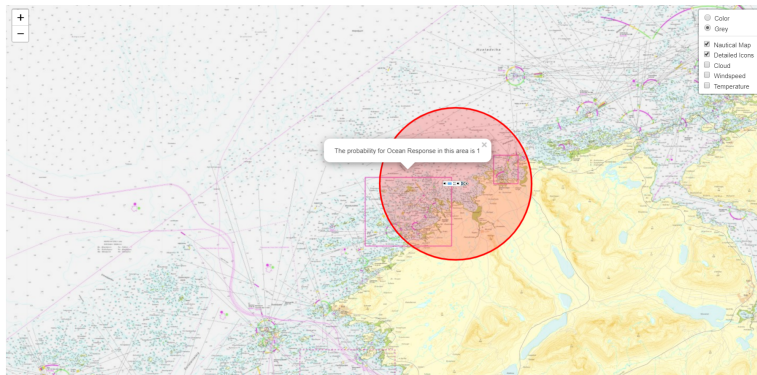

Figure 4.8: Visualization of AI analysis.

Fig. 4.8 shows an example of how the map presents AI analysis. An area showing probability is presented to RC by the map on this layer, which means in this circle you have such probability to find this object according to analysis from the AI system.

4.4 Implementation

This section describes the implementation of this AI-SAR application from the perspective of the system. In the previous chapter, we have illustrated the benefit of visualizing data by three categories. We will describe the details on how to implement data visualization on the Presentation Layer for mapping data, environmental data, and application object data in **Section 4.4.1**, **Section 4.4.2**, and **Section 4.4.3**, respectively.

4.4.1 Mapping Data

Mapping data are used to construct the underlying geospatial map on GUI. When the system engine renders the application scene, the geospatial map represented by mapping data is generated first. The mapping data are usually static during the running of the application, so the map rendering engine only needs the geospatial coordinate system value rather than time value.

Fig. 4.9 shows the process of mapping data visualization and reveals how the different components of the system participate in this. In the figure, the solid line indicates the internal data flow in the system, while the dotted line means the information from the user. The ellipse refers to the database on the Repository Layer, and the square indicates a component or state of the system. First, the system has a pre-set initial map state. According to this state, the Control Layer will query the Repository Layer for the needed data. After obtaining the raw data returned from the mapping data database, the Control Layer will process the data and bind it to a location (x,y,z) . Here x means latitude and y means longitude, z is the zoom level. After these data are transmitted to the Presentation Layer, the data visualization modules will display them on the GUI. When the GUI receives the user's operation, what the Presentation Layer showing to user need to be changed. At

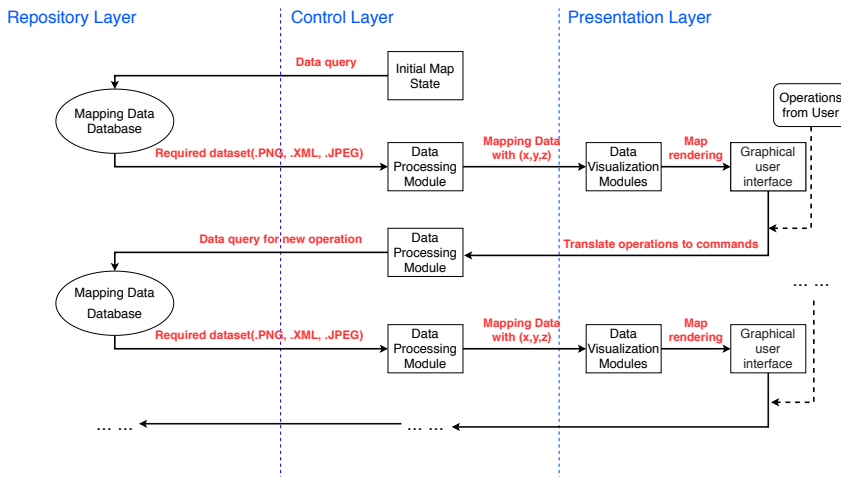

Figure 4.9: Process of mapping data visualization.

this time, the Presentation Layer will send a request to the Control Layer according to the geospatial map content that needs to be displayed for user. Then the Control Layer will send a query to the Repository Layer again. The system will repeat the above process at the running time of application.

4.4.2 Environmental Data

In the AI-SAR system, environmental data refer to the weather condition, temperature, air pressure, humidity, and wind speed at a particular location on the map. Similar to the Presentation Layer which needs the value of x, y, z to visualize mapping data, this layer needs the value of x, y, t (time) to visualize environmental data.

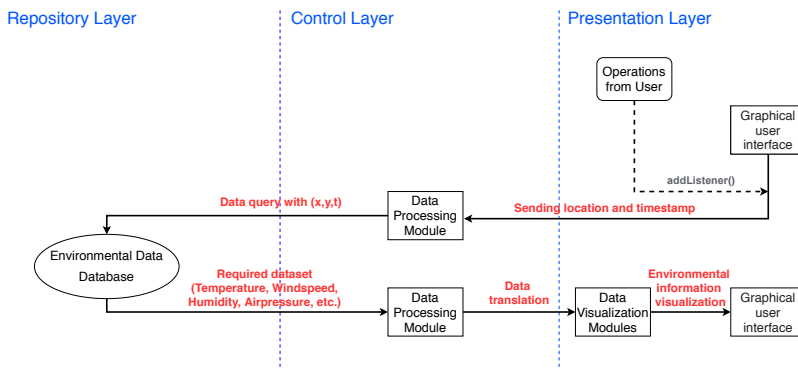

Figure 4.10: Process of environmental data visualization.

In order to save resources, the system would not perform environmental data visual-

ization before receiving the user request. After the user makes an operation that requires environmental information in one position on the map, the Presentation Layer will send the latitude and longitude of this position and the timestamp of the user’s operation to the Control Layer. The Control Layer would send a query to the dynamic environmental data database on the Repository Layer based on (x, y, t). Then the Control Layer will process the data from the Repository Layer, and translate it into the data understandable for the Presentation Layer. The data visualization modules on the Presentation Layer will display required environmental information on GUI. **Fig. 4.10** illustrates this process.

Unlike the process of mapping data visualization, the process of environmental data visualization is only executed when requested by the user. A function *addlistener()* is deployed on the Presentation Layer, which is used to listen to user’s operation about environmental data. Only when this listener function is triggered, the system will execute the process.

4.4.3 Application Object Data

In the AI-SAR system, application object data represents all data belonging to our SAR object (ships, helicopters, and harbors). These data include not only their primary attributes (e.g., name, ID), but also the system’s support analysis (e.g., probability hypothesis).

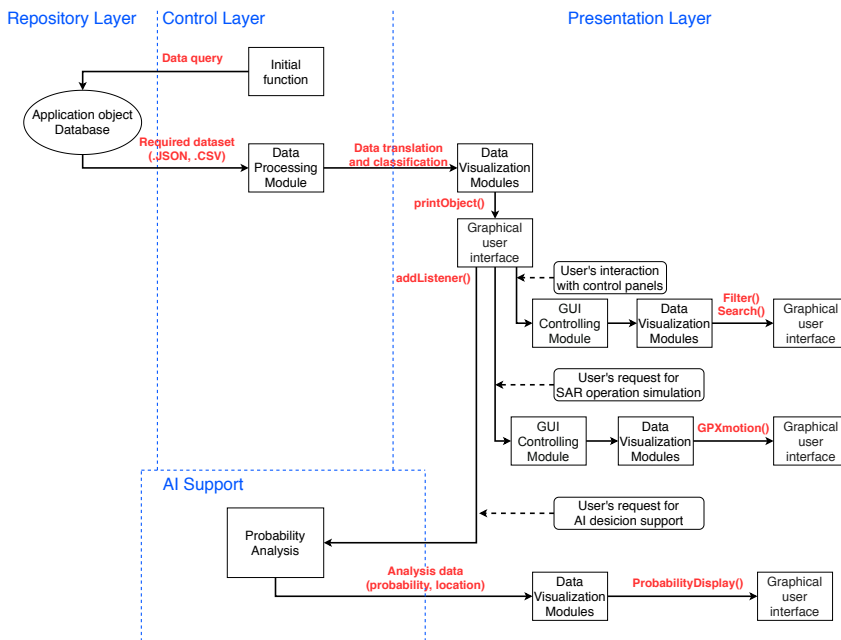

Figure 4.11: Process of application object data visualization.

Fig. 4.11 shows the process of application object data visualization and the cooperation of entire system. When the system is initialized, the Control Layer sends a data query to the Repository Layer and receives the data set containing the ObjectID, ObjectType,

ObjectName, time, icon, location, etc. After the translation and classification of the data set by the data processing module, the data visualization modules obtain the processed data and visualizes a part of the application object data through the function *printObject()* (**Algorithm 1**). The purpose of this function is to divide the objects into different sets by checking the type of the objects, so that the GUI can display them on the map separately. The advantage of this is that it is convenient for the map rendering engine to generate targets on the map. It is also easy for users to perform related operations.

For the remaining application object data, the Presentation Layer sets a series of listener functions for user operations. If the user uses a classification function on the control panels of the GUI, a listener function will be triggered, and the GUI will assign instruction to the GUI Controlling Module. The purpose of the GUI controlling Module is to coordinate the data visualization modules to perform the required data visualization through the internal functions. If another listener function obtains the user's request for SAR operation simulation, the GUI will demand the data visualization modules through GUI controlling module to animate the simulation process. Then, the data visualization modules will execute *GPXmotion()* function designed for SAR simulation visualization. Similarly, if the user wants to request decision support, a listener function will translate the command to the AI support subsystem. After the analysis of components in the AI support subsystem is finished, the analysis result will be transmitted back to the Presentation Layer, and then the data visualization modules will implement the hypothesis data visualization through the *ProbabilityDisplay()* function (**Algorithm 2**).

Algorithm 1 printObject()

```

1: procedure PRINTOBJECT(O)
2:    $O \leftarrow$  list containing all objects
3:    $o.T \leftarrow$  type of this object
4:    $S \leftarrow$  list containing all ships
5:    $H \leftarrow$  list containing all harbours
6:    $A \leftarrow$  list containing all aircraft
7:   for each o in O do
8:     if o.T = ship then
9:       ADD(S, o)
10:    else if o.T = harbour then
11:      ADD(H, o)
12:    else if o.T = aircraft then
13:      ADD(A, o)
14:    end for
15:    PRINT(S)
16:    PRINT(H)
17:    PRINT(A)
18: end procedure

```

Algorithm 2 ProbabilityDisplay()

```
1: procedure PROBABILITYDISPLAY( $O_p$ , P)
2:    $O_p \leftarrow$  list containing all objects with probability
3:    $P \leftarrow$  list containing all probabilities
4:    $o.p \leftarrow$  probability for this object
5:   if  $o$  in  $O_p$  then
6:     for each  $o$  in  $O_p$  do
7:        $FIND(o.p, P)$ 
8:        $PRINT(o.p, o)$ 
9:     end for
10: end procedure
```

Case Study B: Smart Building

This chapter concerns a case study on Smart Building. We have implemented a Smart Building application based on the proposed architecture. The chapter starts with an overview of the Smart Building application in **Section 5.1**, and continues with a presentation about how this application is structured in **Section 5.2**. After that, the GUI of this application is described in **Section 5.3**. The chapter ends with providing some details from the implementation aspects in **Section 5.4**.

5.1 Overview

The Smart Building application is designed to help managers understand the conditions of their supervised buildings, thereby improving their internal environment by possibly actively responding to problems, executing, and updating maintenance plans. Information about buildings usually has geographical characteristics, and managers often need the help of decision support systems. Therefore, we investigate the use of our architecture of GIS for decision support in the context of a Smart Building application.

Assuming that a manager needs to keep track of environmental conditions of several buildings, a GIS for decision support would be of great value in such management activities. First, this system can store and process data about managed buildings. Second, this system can provide a visualization tool to help him/her receive and analysis this information more intuitively. Third, after obtaining this information, the system can support analysis and decision-making. We also consider that for such application, the following factors should be taken into account:

- The map-based GUI must be straightforward for managers to perform and the geographic information available for supporting the decision-making process needs to be clear and concise.
- It should be easy for users to distinguish the scenes from inside and outside the building.

- For data visualization, the GUI needs to ensure the accuracy of real-time data and also to be applicable to the display of historical data.

Based on these considerations, we implemented a Smart Building application on the top of our proposed architecture.

5.2 Architecture

In this section, the architecture of the devised Smart Building application is described. Considering the purpose of this application, we suggest a structure of a GIS with a more complex Presentation Layer based on the basic architecture of a GIS for decision support.

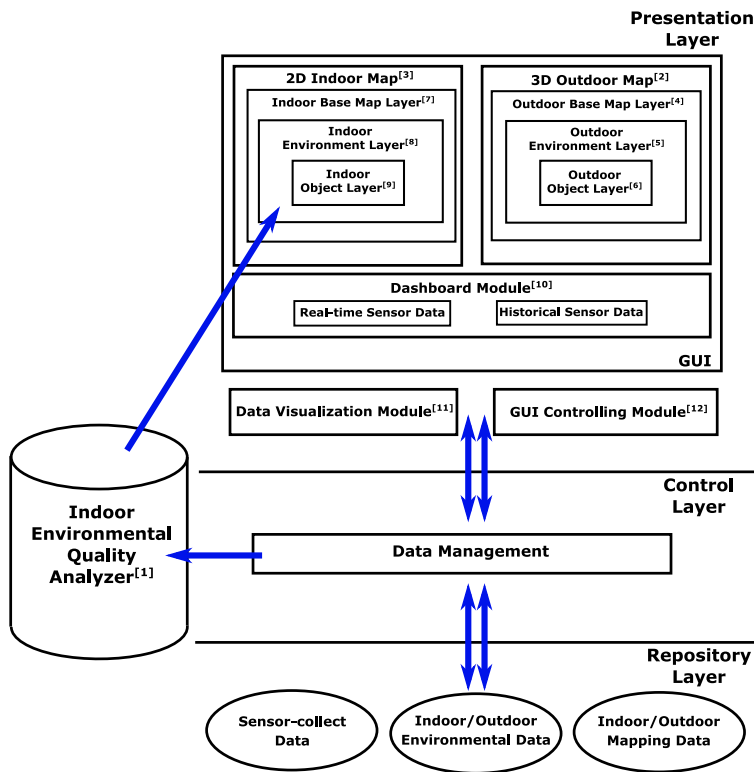

Figure 5.1: Architecture of the designed Smart Building application.

Fig. 5.1 presents the suggested architecture of Smart Building application, which is comprised of three layers and one decision support subsystem: Repository Layer, Control Layer, Presentation Layer, and Indoor Environmental Quality Analyzer.

The Repository Layer is where the system stores the relevant data that we divide as mapping data, environmental data, and application object data. For the Smart Build-

ing application, these three classes of data would be Indoor/Outdoor mapping data, Indoor/Outdoor environmental data, and collected sensor data, respectively. The mapping data for indoor and outdoor maps are from the open-source map database and obtained by the system as images. The outdoor environmental data are mainly provided by online repository, and the indoor environmental data refer to data obtained from local environmental sensors. The collected sensor data represent application object data in this application, which will be processed by the system and displayed on GUI so that the user can obtain the information for objects of Smart Building application.

The Control Layer is in charge of processing the data from the Repository Layer and transferring data flow between layers or between a layer and the analyzer subsystem. In the Smart Building application, the Presentation Layer is required to visualize various types of data in multiple approaches, so the essential function of the Control Layer is to translate the data into the form that Presentation Layer requires and transmit translated data to the corresponding visualization modules on the Presentation Layer correctly.

The Presentation Layer mainly consists of the GUI of this application and two functional modules. The GUI is where the system presents its capabilities to users and receives user interaction. It contains a 3D outdoor map for visualization of the building's condition and a 2D indoor map to visualize the environmental quality of rooms. The outdoor map can be divided into three layers: Outdoor Base Map Layer, Outdoor Environment Layer, and Outdoor Object Layer, for displaying three categories of data. The Outdoor Base Map Layer is where the GUI renders the underlying map of this 3D map; the outdoor mapping data originally from the Repository Layer are presented here. The 3D map rendering engine would visualize the outdoor environmental data like the sunlight on the Outdoor Environment Layer. Outdoor Object Layer is used to contain the objects of this 3D map: buildings, where the map rendering engine would display all information related to objects.

Similarly, the indoor map can also be divided into three layers: Indoor Base Map Layer, Indoor Environment Layer, and Indoor Object Layer. Another map rendering engine for 2D map visualizes indoor mapping data (e.g., the number of floors, the layout of rooms) on the Indoor Base Map Layer and indoor environmental data (e.g., the occupancy of space, indoor activities) on the Indoor Environment Layer. Since rooms are the objects users care about on the indoor map, the data for each room of a building are visualized on the Indoor Object Layer. Moreover, the analysis results from the Indoor Environmental Quality Analyser would also be presented on this map layer to help users understand the situation of rooms. Due to the complexity and diversity of sensor data of rooms, the GUI deploys a Dashboard Module to display sensor data at the current or past moment.

The data visualization modules are connected to the different map layers on the GUI and used to change the content of visualization on the Presentation Layer. The GUI Controlling Module can help the Presentation Layer to convert user interaction received from the GUI into logic commands. If the Presentation Layer could implement the user's requirement internally, these commands will be passed to the Data Visualization Module, and then the data visualization modules can execute corresponding adjustments on the GUI. If the request from the user requires cooperation from the other parts of this system, the Presentation Layer will forward the commands to the Control Layer. After executing commands, the Control Layer assign the tasks to corresponding components to implement

the user's requirement.

The Indoor Environmental Quality Analyser is the decision support subsystem that assists users to analyze the data for indoor environmental quality. It is expected to evaluate the indoor environmental quality according to the collected sensor data transferred from the Control Layer and send analysis results to the Presentation Layer. This subsystem could contain a mathematical model for indoor environmental quality, a relevant expert system, or just some simple evaluation criteria set by users.

5.3 Double-scale Map Interface

This section illustrates the Graphical User Interface (GUI) of this application, which mainly contains one 3D outdoor map and one 2D indoor map. The structure of this double-scale map interface is presented first to give the reader a brief understanding of the GUI. Then, we will describe how to visualize the data related to the indoor the outdoor scales on a single-map interface.

5.3.1 Map Structure

As mentioned before, a map-based interface is an essential part of a GIS application. For the managers of one particular or various buildings, the map-based interface can help them understand the environmental conditions so that they can properly arrange maintenance measures. Also, when buildings are encountering some abnormal situations, the map-based interface can help managers quickly address the location, time, and reason, thus enabling them to take actions as soon as possible. In summary, the map-based interface can help them effectively obtain feedback from the decision support system and assist managers in making accurate and quick decisions.

On the one hand, maintenance personnel or managers need to pay attention to the overall situation of the building by comparing its conditions with those of other buildings. On the other hand, the internal situation of each building provides valuable information about specific locations. For example, information about space occupancy of one floor or the environmental quality of each room could be used to trigger specific maintenance operations. Therefore, based on managers' needs, we have proposed a double-scale map interface for Smart Building.

Fig. 5.2 shows the basic structure of the map interface. It can be divided into one 3D outdoor map and one 2D indoor map. For both maps, we have followed the framework proposed in **Chapter 3**. The map rendering engine generates three map layers for each map so that data visualization modules could visualize mapping data, environmental data, and application object data on different map layers.

5.3.2 Outdoor Map

Considering the spatial complexity of the outdoor scale, the outdoor map on the GUI uses a 3D map rendering engine. Therefore, no matter underlying map tiles, environmental data, or the building models, they are all required to be input in 3D format. **Fig. 5.3** shows the map layers on this 3D map.



Figure 5.2: Structure of Double-scale map.

On the Outdoor Base Map Layer, the data visualization modules visualize the mapping data for 3D earth. As the beneath map layer, it only needs to display the most basic geospatial information. Because the purpose of the 3D outdoor map is to help building managers to receive information of buildings from the outdoor scale, the Outdoor Base Map Layer mainly displays the geographic location information of the target buildings and the distribution of surrounding streets and blocks, so that managers can understand the surrounding geographic spatial information from this map layer.

The Outdoor Environmental Layer is used to represent the overall environment in which the target building exists. **Fig. 5.4** shows an example of a screenshot from the 3D outdoor map, where the sunlight at realtime is simulated to support managers in analyzing the effect of sunlight on buildings. As a basic environmental factor, sunlight could affect the buildings in many ways. For example, sunlight is significant in the analysis of the energy use of buildings. The sunlight will affect the lighting and heating of the building to some extent, which will further affect the energy use of the building. Considering the necessity of sunlight for Smart Building application, we have partially implemented the visualization of sunlight, and we have seen many possibilities for the Outdoor Environmental Layer. For example, we suppose the GIS for Smart Building can gather data of noise level around the buildings, so the Presentation Layer could visualize the noise dis-

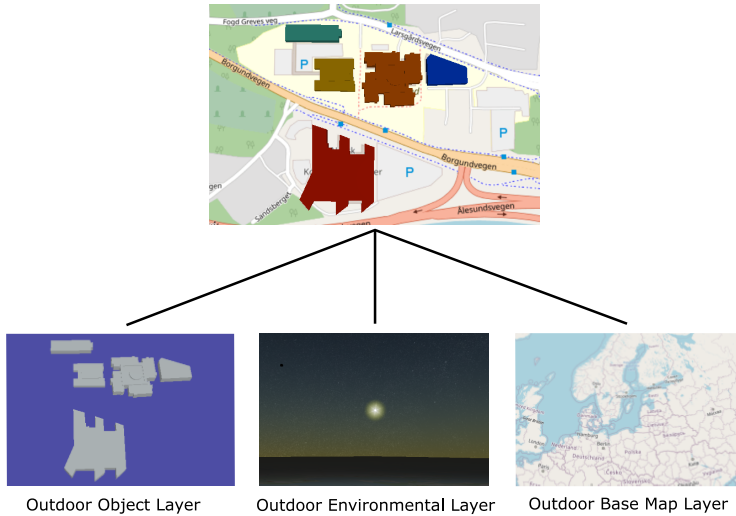

Figure 5.3: Three map layers on outdoor scale.

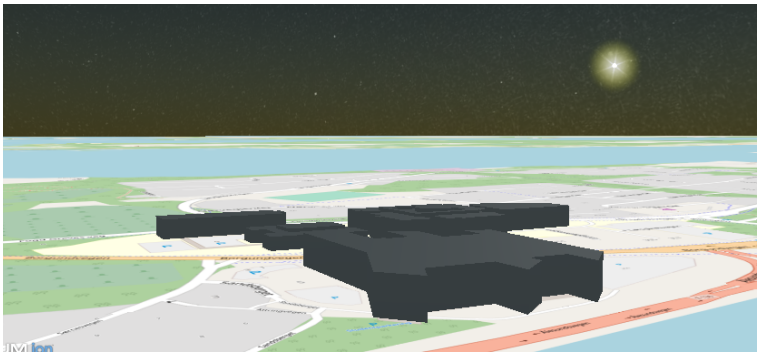

Figure 5.4: Sunlight on 3D outdoor map.

tribution on this map layer to help managers reduce noise pollution effectively. Another usage possibility would be to visualize the precipitation data in the area where the building is located. With visualization of precipitation, the manager can recognize which parts of buildings are more vulnerable to rain, so they could take measures to prevent potential troubles. Other similar usage scenarios (e.g., visualization of wind and visualization of light pollution) on this map layer are also expected to improve this application’s capabilities.

The object of our concern is the building on the outdoor scale, so the Outdoor Object Layer is essentially rendered for the buildings. In this case, we pick five buildings from NTNU in Ålesund as the objects. These five buildings are modeled to 3D models by the real size and are located as the entities on 3D map in the geographical position of reality,

aiming to fit the geospatial information provided by the Outdoor Base Map Layer.

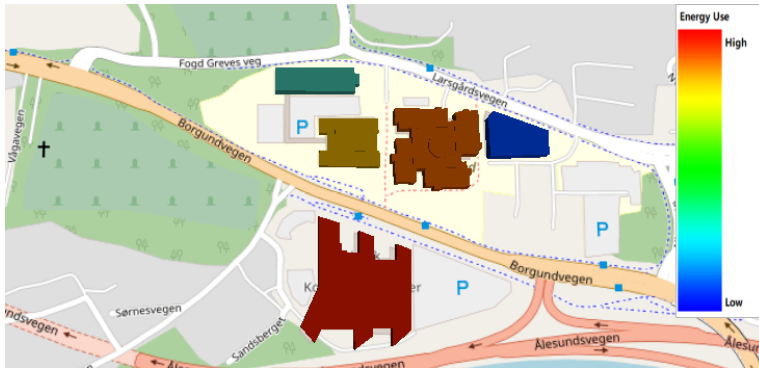

Figure 5.5: Energy use visualization of buildings.

At present, we have temporarily implemented two functions on this outdoor map. One is the visualization of energy use, which indicates different usage of power by rendering different colors to the buildings. From blue to red, the map shows the energy use from low to high. This function is designed to help managers understand the energy use of buildings and compare the usage of different buildings to perceive the overall situation of buildings or assist them in making energy-saving measures. **Fig. 5.5** displays an example of a screenshot from the 3D outdoor map illustrating the visualization of the energy use of buildings.

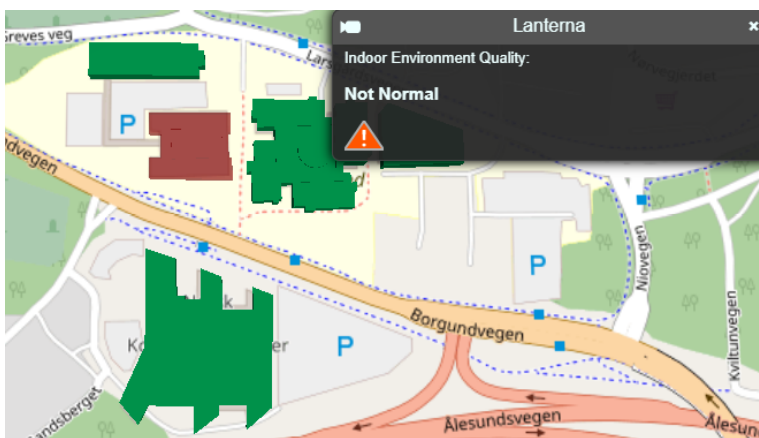

Figure 5.6: Indoor environmental quality monitoring of buildings.

Fig. 5.6 shows another function of this outdoor scale map associated with the task of monitoring the Indoor Environmental Quality (IEQ) from the building's perspective. Taking the situation in the figure as an example, we can see that the surface of the building named "Lanterna" is displayed in red, which symbolizes that the building has indoor environmental problems. In this case, the manager can click on this building to navigate to the

2D indoor map, which we will describe in more detail in the next section. The function of IEQ monitoring aims to help managers understand the internal conditions of the buildings under their management at any time, and allow them to detect and respond to indoor environmental issues quickly.

5.3.3 Indoor Map

For the indoor scale of the GIS for Smart Building, most of information and data is in 2D, so a 2D indoor map can thoroughly meet the requirement of managers. Considering that 2D maps usually save more system resources than 3D maps, which we have illustrated before, we implement a 2D indoor map with multi floors for the indoor scale.

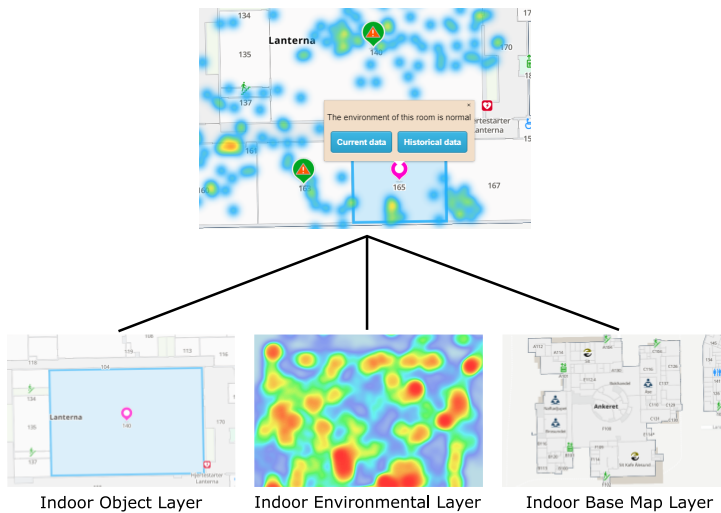

Figure 5.7: Three map layers on indoor scale.

As mentioned in the previous section, managers can navigate from 3D outdoor map to 2D indoor map so that they can obtain the information about the internal conditions of the buildings under their management. The basic structure of this 2D indoor map is similar to the 3D outdoor map; it can also be divided into three map layers: Indoor Base Map Layer, Indoor Environmental Layer, and Indoor Object Layer. **Fig. 5.7** shows these three map layers that make up the indoor map.

As the bottom layer of the indoor map, the Indoor Base Map Layer shows the most basic spatial information inside the building, such as the layout of each floor, the type and distribution of rooms, and the locations of stairs or elevators. The 2D map rendering engine also provides users with the function of floor switching, so that the Indoor Base Map Layer can display the spatial information of each floor on a 2D map.

The Indoor Environmental Layer is used to display the environment inside the building. The Environmental Data Visualization Module for indoor map visualizes the data

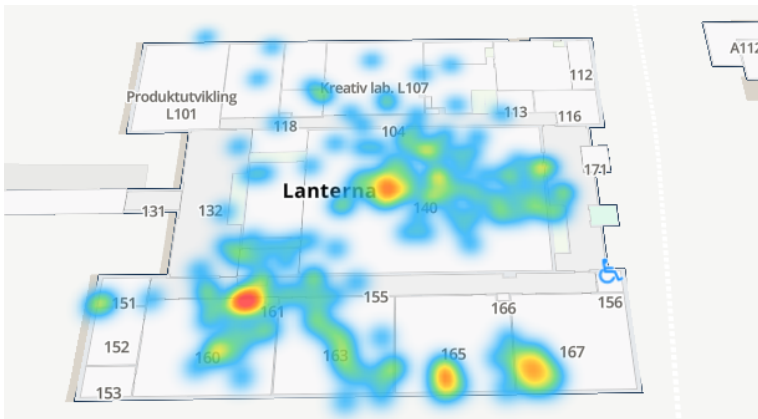

Figure 5.8: Heatmap of occupancy.

from the indoor environmental database on this map layer. The purpose of the Indoor Environmental Layer is to help managers to obtain information about the internal condition of one building or one floor so that they can consider how such an indoor environment will affect the building or some rooms. **Fig. 5.8** shows a screenshot from the indoor map, which presents an approach to visualizing indoor environmental data on the Indoor Environmental Layer. Here, the occupancy of space is visualized as a heatmap covering a floor on the Indoor Environmental Layer. We suppose the data on occupancy are based on phone activity, so managers would be able to estimate the distribution of the crowd. Then they could analyze if such a distribution of people would cause some indoor issues.

The application objects that the managers are concerned with on this 2D indoor map are rooms on each building. Therefore, the GUI allows the data visualization module to display the data related to individual rooms on Indoor Object Layer, so every room in the buildings is regarded as the objects. Managers can obtain detailed information about each room on this map layer with the goal of carrying out indoor environment analysis based on this information. Most data visualized on this map layer are collected by indoor sensors. Because these sensors collect many types of data in the room and store them on the Repository Layer consistently, this leads to a large amount of data. To perform the visualization of this massive dataset, we deploy a Dashboard Module to visualize the sensor data; the specific details about this Dashboard Module will be described in the next section.

The analysis results from the Indoor Environmental Quality Analyzer will also be displayed on the Indoor Object Layer. As a subsystem for decision support in Smart Building application, Indoor Environmental Quality Analyzer is expected to receive related data and output the analysis to building managers. The analysis generated based on data of indoor environment and room sensors would be transmitted to the Presentation Layer and visualized on GUI, aiming to assist managers to evaluate the situation of a floor or a room. **Fig. 5.9** shows an example of the visualization for analysis of the IEQ Analyzer, containing two warnings pop up on the Indoor Object Layer. One is indicating that one room is overcrowded based on the occupancy sensor; the other one is showing the CO₂ level of

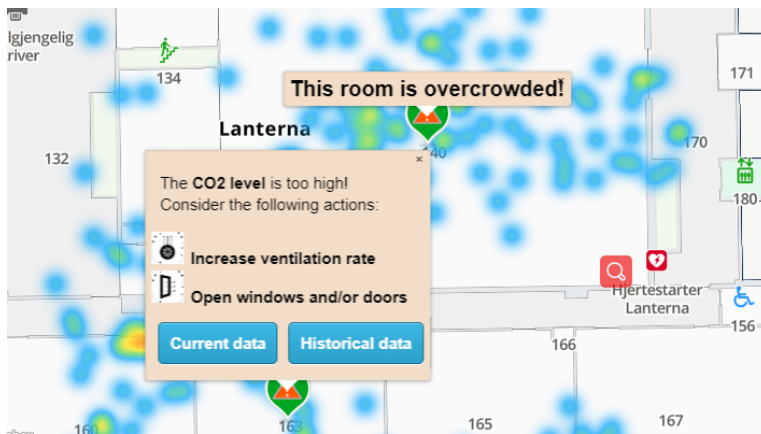

Figure 5.9: Warnings from IEQ analyzer.

one room is too high as well as the following suggestions from analyzer. Managers can refer to this information to make better decisions.

5.3.4 Dashboard

On the GUI of Smart Building application, we have designed a Dashboard Module for the visualization of sensor data. Though the dedicated Dashboard Module, managers could check the current sensor data and past sensor data of a room quickly.



Figure 5.10: Current sensor data and historical sensor data.

Fig. 5.10 shows the process of using the Dashboard Module on the indoor map. After clicking on buttons over the room information pop-up widget, managers can see two dashboards displaying the sensor data at current and sensor data from the past.



Figure 5.11: Comparison of pressure and humidity trends.

In the historical data part, the Dashboard Module presents the data with the a line chart encoding a time series. The managers can also zoom in to view the value of a parameter at a particular timestamp. Besides, the Dashboard Module also provides a comparison function for historical data, which is convenient for managers to analyze the correlation between different variables. For example, **Fig. 5.11** shows a comparison of pressure and humidity trends.

5.4 Implementation

The implementation of this Smart Building application is described in this section. Since measurements are handled by the Presentation Layer of the system, this section will focus on indoor and outdoor maps to explain the implementation of the application.

5.4.1 3D Outdoor Map

The 3D outdoor map is implemented on the top of the CesiumJS library, and the code is written in JavaScript. The Presentation Layer provides a dedicated area to contain the 3D outdoor map on GUI and creates a canvas in this container for 3D map rendering. The rendering for 3D scene and data visualization on the 3D map will be performed by the 3D rendering engine and the Data Visualization modules, respectively.

Fig. 5.12 shows the necessary process of data visualization on 3D outdoor map. In the first part of this process, all the required datasets are sent from the Repository Layer to the Data Processing Modules on the Control layer, and they are transferred to the Presentation Layer after data processing. During the execution of data processing, geographical positions are attached to mapping data in the dataset and environmental data are processed to a sunlight model with time series. Object data are represented by several datasets before data processing, and the Control Layer combines them into one collection of objects.

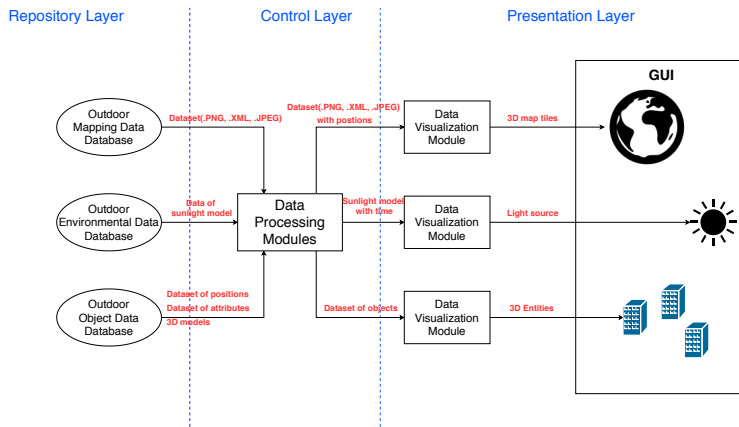

Figure 5.12: Process of data visualization on 3D outdoor map.

In the next step, the data visualization modules on the Presentation Layer would perform data visualization based on the data they received. The mapping data will be visualized as 3D map tiles that compose the underlying map, the sunlight model will be visualized as a movable light source in the 3D scene, and the object data will be visualized as 3D entities. Then the 3D map rendering engine will render them on the 3D outdoor map in the last step.

5.4.2 2D Indoor Map and Dashboard

After the GUI acquires the user's click event on a target building on the outdoor map, the Presentation Layer will generate a 2D indoor map in another dedicated area on the GUI. In the actual use, the indoor map can be regarded as an extension of the data visualization of the outdoor map, as it is used to display the internal information of an object from the 3D outdoor map. Therefore, in the implementation, the user's operations from the 3D outdoor map can influence the generation of the 2D indoor map. Similarly, the dashboard can also be regarded as an extension of the data visualization of the 2D map, so the operations on the 2D map should affect the generation of the dashboard module.

The 2D indoor map is implemented with JavaScript and based on MazeMap JS API. Although this indoor map can also be zoomed out of the building, the outdoor information is rarely displayed on the indoor map. The primary data visualization capacity of this indoor map is performed inside the building.

Fig. 5.13 shows the process of data visualization on a 2D indoor map. In the first step, datasets from three categories of database are forwarded from the Repository Layer to the Control Layer. The indoor mapping dataset includes the images (e.g., PNG file and JPEG file) used to constitute the basic map and the GeoJSON file that is eventually used to create the room polygons on the indoor map, while the environment dataset contains the data to represent the indoor environment, and object dataset contains the data related to rooms. In the next step, the Control Layer executes data processing for each dataset and transmits these data to other components in the Smart Building application. Most of the processed

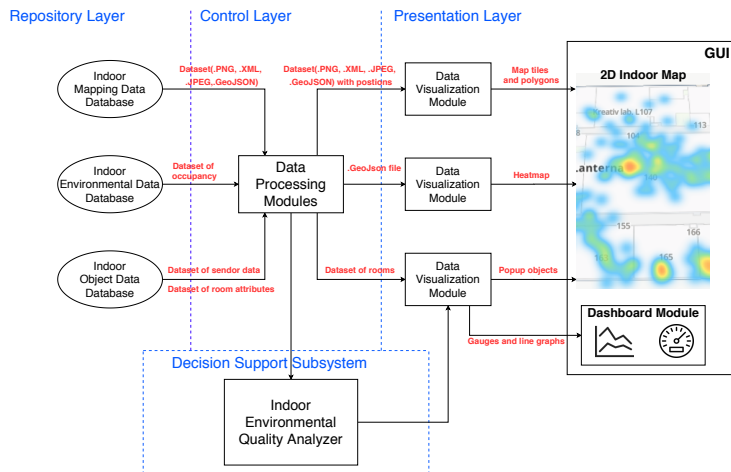

Figure 5.13: Process of data visualization on 2D indoor map.

data are transferred to the corresponding data visualization module on the Presentation Layer, and the others are packaged and sent to the Indoor Environmental Quality Analyzer for the following analysis support. The step after that is the data visualization on the Presentation Layer. The Mapping Data Visualization Module converts the obtained data to 2D map tiles constructing the base map and 2D polygons representing rooms on the indoor map. To visualize the indoor environment, the Environmental Data Visualization Module produces a heatmap on the indoor map based on the GeoJSON file obtained from the Data Processing Modules. The Application Object Data Visualization Module receives input from two resources: Data Processing Module for indoor object data and the IEQ Analyzer. For providing primary information of rooms, the Application Object Data Visualization Module visualizes it through popup objects upon the room on the map, while the sensor data is displayed in the Dashboard Module.

Evaluation and Discussion

In this chapter, we describe a conducted user-based study aiming to evaluate a developed prototype in **Section 6.1**. Furthermore, the results from the investigation of two case studies and the limitations of our implementation are discussed in **Section 6.2**.

6.1 Evaluation

The evaluated prototype is the GUI of Smart Building application from our Case Study B. We implemented this evaluation with the participation of a set of volunteers. Considering that SAR systems are expected to be used in the more professional field, we have not carried out a user-based evaluation for Case Study A in this thesis.

6.1.1 Evaluation Protocol

The arrangement of the performed evaluation follows the evaluation framework DECIDE described in **Section 2.5**. This section explains the details of each procedure adopted in our evaluation protocol.

Determine the goals. The goal of this experiment is to evaluate the Graphical User Interface of the proposed GIS application for Smart Building. We expect to demonstrate that this GUI can allow users to interact with the Smart Building application effectively, thus validating the feasibility of the proposed framework of GUI.

Explore the questions. Some questions are defined for assessing users' feedback regarding the operation on GUI. Addressed research questions can be summarized as follows:

- Is it possible for users to perform several practical tasks on this GUI? And are these tasks easy for users to complete?
- Is it easy for users to identify or perceive the content of visualization?
- Are users satisfied with the visual appearance of this GUI?

Some open questions are also defined, so that users can provide comments about the GUI or about unaware information.

Choose the Evaluation Paradigm and Techniques. Considering that there will be various evaluators participating in the assessment process, and much of their feedback is based on the user's subjective preferences, we designed a questionnaire as the evaluation instrument.

Identify the Practical Issues:

- **Users:** We invited a set of bachelor, master, and doctor students from NTNU, in a total of 14 participators. Any age or gender were accepted in this experiment. None of them have operated the developed GUI before the evaluation experiment.
- **Equipment:** Each participant was asked to access the GUI and the created questionnaire through their own device (computer or mobile device).
- **Material:** The materials concerning this evaluation experiment include:
 - User instructions: it shows users what they need to know for this evaluation experiment, such as the purpose of evaluation, the procedure of this experiment, ethical issues, etc.
 - Webpage to access GUI: The developed GUI was published on an online webpage, and participants were asked to access this GUI through a given Uniform Resource Locator (URL) from the browser on their devices.
 - Operation guide: In the beginning, a short video was used to introduce the main features of our application and how to interact with the developed GUI. At each step of the experiment, some detailed guidance was also provided to assist the participants in completing the assigned tasks.
 - Participant profile form: It was used to capture the background information of participants, such as their educational level and familiarity with Geographic Information System and data visualization approaches.
 - Evaluation form: It contained the predefined questions regarding the operation on the GUI. We captured participants' judgments and preferences from those questions.

Decide how to deal with the ethical issues. Ethical issues were explained to the participants in the user instructions.

Evaluate, Interpret, and Present the Data. In the first step, we provided the participants with the user instructions and the link to access the GUI. Then, participants were asked to access this GUI on their devices. Before the operation, participants were required to fill the profile form. In the next step, they were free to study the operation guide to understand how to operate this GUI. After that, participants were expected to perform tasks on this GUI. Finally, they provided feedback regarding the operation on the GUI through the evaluation form.

6.1.2 Profile Form and Evaluation Form

As mentioned in the previous section, the profile form allows us to collect information about participants, while the evaluation form enables us to obtain users' judgments and preferences.

The questions on the profile form were divided into two categories: the first was focused on obtaining information about the age and education of participants, while the other aimed to understand their familiarity with the domains involved in the GUI. To characterize the familiarity of participants with our study fields, we have defined the following four questions:

- How familiar are you with map-based applications (e.g., Google Map, Bing Map, Mazemap, etc.)?
- How familiar are you with geographic information systems (GIS)?
- How familiar are you with information visualization approaches?
- How familiar are you with sensor-based data analysis?

The participants were asked to indicate the scale (from 1 to 5) for their familiarity. In the scale: 1 means not familiar at all; 2, somewhat unfamiliar; 3, medium; 4, somewhat familiar; 5, very familiar.

The evaluation form comprises three steps. In each step, the participants were asked to perform one task that may happen in actual practice on our GUI, and then present the outcome of this task on the evaluation form. After that, participants were expected to answer several questions based on their operation experience while executing the assigned task. These questions in each step can be essentially divided into two types: one is about the usability of the GUI, while the other is about the visual appearance quality of the GUI. Through these questions, we can capture the judgments and preferences of participants. Since each task involves different functions and elements of our GUI, we can summarize and analyze judgments and preferences of users.

In Task 1, participants were asked to rank the energy use of buildings based on the information they can get from the outdoor map. To obtain feedback on the GUI's usability regarding Task 1, we requested the participants to answer two questions after they completed this task:

- How do you rate the degree of difficulty for performing Task 1?
- How easy is the identification of the relation between the energy use and the displayed color of buildings?

The participants were asked to indicate the scale (from 1 to 5). In the scale: 1 means very easy; 2, somewhat easy; 3, neither easy nor hard; 4, somewhat hard; 5, very hard.

To capture the participants' judgments and preferences of the visual quality displayed by the GUI during the performance of Task 1, we provided the following questions on the evaluation form:

- How do you rate the degree of satisfaction with the colors used in Task 1?
- How do you rate the degree of satisfaction with the position of gradient label (on the left side of map) in Task 1?

The participants were asked to indicate the scale (from 1 to 5) for their degrees of satisfaction. In the scale: 1 means very dissatisfied; 2, somewhat dissatisfied; 3, neither satisfied nor dissatisfied; 4, somewhat satisfied; 5, very satisfied.

In addition to the above questions, we also provided open questions for participants after each task. The analysis of answers to these questions will be presented later.

Task 2 concerns to find one particular building with indoor environmental quality problem and try to find the problems in this building. This task requires the users to operate on the outdoor map and identify the building with indoor environmental quality problem. Also, the user was expected to navigate from the outdoor map to the indoor map and then obtain the information from the indoor map.

After the participants completed the operation on GUI for Task 2, they provided their judgments on the usability through four questions from the evaluation form:

- How do you rate the degree of difficulty for performing Task 2?
- How easy is the identification of the building with indoor environmental quality problem?
- How easy is it to navigate from the outdoor map to the indoor map?
- How easy is the identification of the room with indoor environmental problem?

The participants were asked to use the same scale used in the previous task.

The developed GUI is expected to help users obtain information from the map by giving them corresponding visual signs when performing this task. Therefore, our evaluation of the quality of GUI visual appearance regarding Task 2 is mainly based on that. The following questions were defined in the evaluation form:

- How do you rate the degree of satisfaction with the provided introductory text on the indoor map?
- How do you rate the degree of satisfaction with the warning marker on the map?

The participants were asked to use the same scale used in the previous task.

Task 3 concerns to find the highest noise level value from the historical data of a particular room. To complete this task, the participant first needed to find this room on the indoor map, then open the historical sensor data window of this room, and after that, operate over this window to obtain the highest value of noise.

Considering that this task mainly involves the operation of the indoor map and the Dashboard Module, we defined the following questions to obtain the participants' judgments of the availability of operation and the visualization elements.

- How do you rate the degree of difficulty for performing Task 3?
- How easy is the identification of sensor data (e.g., temperature, CO2 level, noise level, etc.) of a room?
- How easy is the identification of sensor data (e.g., temperature, CO2 level, noise level, etc.) of a room over time?

- How easy it is to find the value of sensor at particular timestamp?

The participants were asked to use the same scale used before.

In this step, the evaluation of visual appearance quality is mainly focused on the Dashboard Module. To capture participants' satisfaction, we provided two questions in the evaluation form:

- How do you rate the degree of satisfaction with the display for current indoor sensor data in Task 3?
- How do you rate the degree of satisfaction with the display for indoor sensor data with time series in Task 3?

The participants were asked to indicate the scale value as before.

After participants completed three tasks, we also provided a question to obtain their overall understanding of the GUI.

6.1.3 Results

The answers we collected from the profile form provide us a general understanding of users before the evaluation. **Fig. 6.1** shows the age and education level of participants. We need to mention that since not all questions were answered by 14 participants, in this section, we use percentage rather than quantity to express the obtained results.

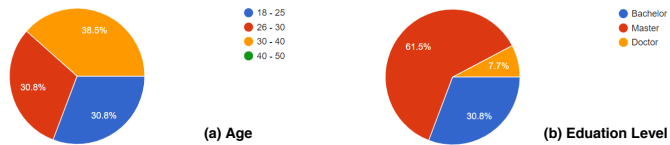

Figure 6.1: Information on age and education of participants.

We also obtained information about their familiarity with map-based applications, Geographic Information System, information visualization approaches, and sensor-based data analysis from the profile form. For map-based applications, 71.5% of participants thought they were somewhat familiar or very familiar with maps, and 21.4% thought their familiarity was at a medium level. However, 78.6% of them believed they were not so familiar with GIS (14.3% were not familiar at all, 42.9% were somewhat unfamiliar, and 21.4% thought they were medium). For information visualization approaches and sensor-based data analysis, the responses of participants are relatively evenly distributed. Most participants thought that they were at or near the medium value. Very few evaluators were very familiar with them or not at all. **Fig. 6.2** shows the distribution of answers for these two questions.

From answers of four questions, we can conclude that, generally speaking, our subjects were familiar with commonly used map-based applications but lack knowledge on GIS,

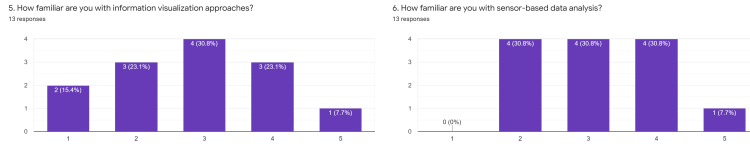

Figure 6.2: Familiarity with information visualization approaches and sensor-based data analysis.

which is usually regarded as an expertize. For information visualization and sensor data analysis, they have varying degrees of understanding and background.

The first part of the evaluation form concerns Task 1 described in the previous section. After performing this task on the given GUI, participants were asked to provide the results of tasks. We noticed that 13 out of 14 subjects provided results. It should be mentioned here that we tracked the evaluation form submitted by this participant who did not offer the task result. We found that he/she answered all other evaluation questions except for not providing the results of the three tasks. Therefore, we were convinced that this participant completed all the tasks, but did not present the results for some reasons. When we analyzed the data of this evaluation experiment, we considered his/her other answers as valid. Out of these 13 subjects, 7.7% presented a wrong answer, 7.7% presented an irregular answer, and the remaining 84.6% were correct (15.4% of them ranked the energy use from low to high, while 69.2% of them ranked the energy use from high to low).

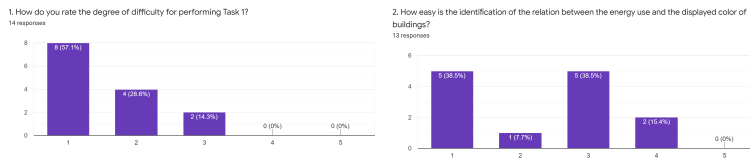

Figure 6.3: Feedback on the GUI usability regarding Task 1.

Next, we collected answers to questions used to evaluate usability and visual appearance quality. **Fig. 6.3** summarizes the judgments of participants regarding Task 1. All the participants thought it was easy or average to perform this task using our GUI. For the identification of an essential visualization element involved in Task 1, 46.2% considered it was very easy or easy, 38.5% thought it was neither easy nor hard, and the remaining 15.4% thought it was a bit hard. Participants generally thought the usability of the GUI was acceptable for performing Task 1.

Fig. 6.4 presents the answers to these questions about visual appearance. For the choice of color, 61.6% of participants gave a positive response, while 23.1% provided a negative response. About the position of the gradient label that is used to indicate energy use of buildings, a total of 71.5% were relatively satisfied with it, 14.3% were neutral with it, and 14.2% were relatively dissatisfied.

The next part of the evaluation form is about questions around Task 2. Similarly, participants showed their performance results to us after executing this task on the developed

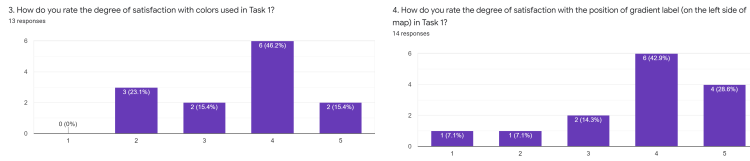

Figure 6.4: Feedback on the GUI visual quality regarding Task 1.

GUI. Out of all the subjects who provided the result of this task, 16.7% only completed the first step, while 83.3% provided the correct result.

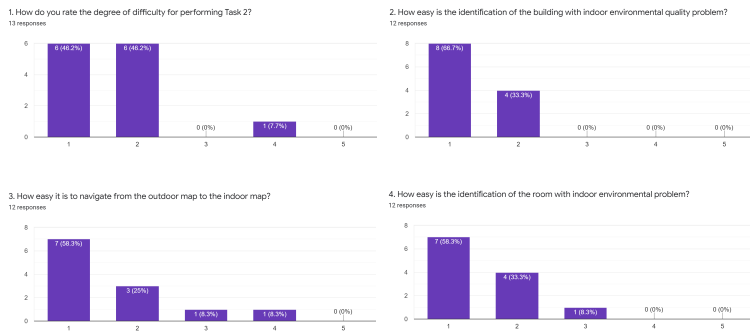

Figure 6.5: Feedback on the GUI usability regarding Task 2.

After completing the operation of Task 2, participants provided their answers to the corresponding evaluation questions, which we described in the previous section. **Fig. 6.5** summarizes the answers to four questions about usability from participants. We can observe that 46.2% of the evaluators rated the difficulty for performing Task 2 was very easy, and the same amount of participants rated it was slightly easy. Only 7.7% had faced some difficulty during this task. Participants provided very positive feedback on the identification of the two important visualization elements displayed by the GUI in Task 2. All of them thought that it was relatively easy to identify the building with indoor environmental quality problem on the outdoor map; 91.7% thought that it was relatively easy to identify the room with indoor environmental problem on the indoor map. Regarding a crucial function of the GUI, the navigation from the outdoor map to the indoor map, we could notice that 58.3% thought it was easy, and 25% thought it was somewhat easy. Only 8.3% of participants considered it was a bit difficult.

For the two questions about visual appearance regarding Task 2, 69.3% of the participants expressed “somewhat satisfied” or “very satisfied” to the introductory text on the indoor map, while 7.7% of the participants were not satisfied with it. In contrast, 96% expressed satisfaction with the warning marker on the map. Comparing these results, we can assume that there is still room for improvement in the introductory text.

The third part of the evaluation form mainly concerns the evaluation based on Task 3,

and the participants' performance of this task were pretty satisfying. After performing this task, all participants who submitted the result provided the correct answer.

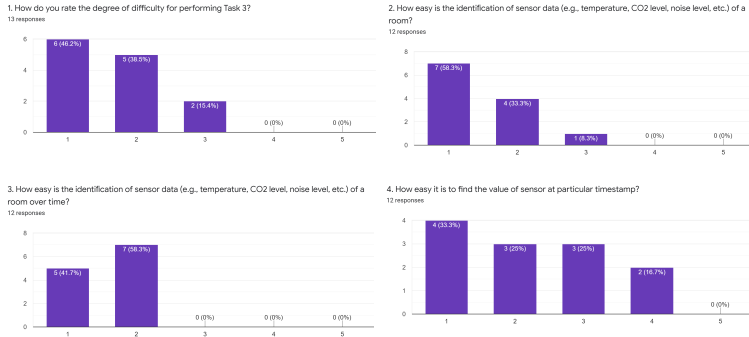

Figure 6.6: Feedback on GUI usability regarding Task 3.

For questions about usability regarding this task, **Fig. 6.6** presents the answers we collected from participants. We can observe that 84.6% of participants thought that Task 3 was relatively easy, and remaining 15.4% thought the difficulty was medium. For two significant data visualization content presented in this task, 91.7% and 100% considered it was easy to identify them. Concerning finding the value of sensor at particular timestamp, the indicated difficulty varies for different participants: 33.3% thought it was very easy, the percentages of participants answered “somewhat easy” and “neither easy nor hard” were the same (25%), and 16.7% thought it was a bit hard to find it.

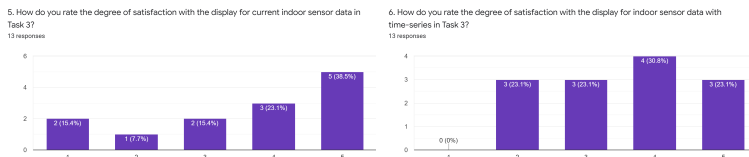

Figure 6.7: Feedback on GUI visual quality regarding Task 3.

Comparing the answers with the ones of Task 1 and Task 2, we can observe from **Fig. 6.7** that the participants' responses to visual quality regarding Task 3 were not very satisfactory. For the display of sensor data in realtime, 61.6% of participants were relatively satisfied with it, and 23.1% of participants were relatively dissatisfied with it. Also, 53.9% of participants were satisfied with the design to display sensor data with time series, while the same percentage (23.1%) thought that they were neutral with it and slightly dissatisfied, respectively.

At the end of the evaluation form, participants were required to answer how do they rate the understanding of operation on this GUI after performing three tasks. 58.3% answered “very understandable”, 16.7% answered “somewhat understandable”, 16.7% thought their

understanding is at medium level, and 8.3% thought “not understandable”.

Table 6.1: Summary of judgments and preferences.

	Task 1	Task 2	Task 3
Success Rate of Performance	84.6%	83.3%	100%
Average Operation Difficulty (1-very easy, 5-very hard)	1.57	1.68	1.96
Average Identification Difficulty (1-very easy, 5-very hard)	2.31	1.42	1.54
Average Satisfaction with Visual Appearance (1-very dissatisfied, 5-very satisfied)	3.67	4.2	3.58

Table. 6.1 shows a statistical summary of the results we collected from the experiment. We evaluated the usability of this GUI based on the performance success percentage of each task, the difficulty of operation for the user, and the difficulty of identifying visualization content. The evaluation of the visual appearance quality is according to their satisfaction. In summary, we think the evaluation result of the current GUI is relatively positive. We can see from this table that most operations and identification were easy for users, and the success rate of completing the given tasks was also very high. Moreover, users are generally satisfied with the visual appearance. Nevertheless, we also have to admit that users’ feedback on visual appearance was relatively less positive, which shows there is still much room for improvement.

As mentioned earlier, we set up questions on the evaluation form to receive suggestions and comments on our GUI and were provided a lot of valuable ideas. For example, one participant mentioned an aspect that we did not consider, “Some people are colorblind and may find it difficult to distinguish between red and green.” Another participant reported the compatibility issue three times: “On a smartphone I had to enlarge before interacting.”, “The second map is taller than the first on a mobile device. I have to enlarge before being able to interact.”, and “Very difficult to interact with a mobile device. I had to switch orientation multiple times.” We also received precise suggestions for improvement, such as “It would be great if the pop-up box contains the value. When you hover over the historical values, it also could include time for the given value. Zooming and navigation in the graph could also be a bit more intuitive. I want a zoom-out function that does not reset the whole graph.”

After summarizing and categorizing these suggestions and comments, we illustrate some of them in **Table. 6.2**. The ranking of suggestions is based on the number of participants who propose it. These suggestions provide directions for future improvements.

Besides, we also explored the performance of participants with different knowledge backgrounds in this evaluation experiment. Considering that only one participant was a bit unfamiliar with map-based applications, and most participants are not very familiar with GIS, we focus this exploration on if participant’s knowledge about information visualiza-

Table 6.2: Summary of the most frequent suggestions provided by evaluators.

Suggestion	# of occurrences
Use less colour to indicate energy use	4
Improve zooming in/out on historical sensor data display	3
Improve compatibility on smartphone	3
Add colour blind mode	2
Indicate the number of energy use on outdoor map	2

tion and sensor-based data analysis affected their performance on our GUI.

After removing the two participants who did not provide all the answers, we divided the remaining twelve participants with different familiarity with information visualization approaches into three groups: Group A includes 4 participants who were familiar with it (they indicated 4 or 5 on profile form); Group B includes 4 participants who were average with it (they indicated 3 on profile form); Group C includes 4 participants who were unfamiliar with it (they indicated 1 or 2 on profile form). We tracked their answers and calculated the average value of the operations and identification in all tasks they rated. **Table 6.3** shows our statistical result.

Table 6.3: Different performance of participants with different knowledge about information visualization.

	Average value (1 refers very easy, 5 refers very hard)
Group A (experienced)	1.75
Group B (average)	1.75
Group C (inexperienced)	1.725

In another statistic analysis, we divided the twelve participants with different familiarity with sensor-based data analysis into three groups: Group A includes 5 participants who were familiar with it (they indicated 4 or 5 on profile form); Group B includes 3 participants who were average with it (they indicated 3 on profile form); Group C includes 4 participants who were unfamiliar with it (they indicated 1 or 2 on profile form). We did the same calculation as the previous one. **Table 6.4** shows our results.

Comparing the two tables, we can see that the participants with knowledge about information visualization approaches did not think the operations and identification on this GUI were easier. In contrast, the participants having high familiarity with sensor-based data analysis could perform given tasks more comfortably. Due to the small sample size and lack of other proof, we temporarily assume that the knowledge of sensor-based data analysis can help users better operate this GUI.

In conclusion, the overall assessment of the our GUI was positive. The participants'

Table 6.4: Different performance of participants with different knowledge about sensor-based data analysis.

Average value (1 refers very easy, 5 refers very hard)	
Group A (experienced)	1.42
Group B (average)	1.83
Group C (inexperienced)	2.075

pleasing performance has proved the GUI's usability, and their background also proved that the users of Smart Building application do not need to have deep GIS knowledge. Although participants in this experiment were generally familiar with map-based applications, as such applications are a kind of common tool nowadays, this is not a harsh requirement for them. Besides, by analyzing the performance of participants, we also proposed an assumption: the building managers with better knowledge about sensor-based data analysis may work with our tool more effectively. Moreover, suggestions from participants provide important direction for improving the Smart Building application in the future.

6.2 Discussion

In this thesis, we proposed the generic architecture of GIS for decision support and development framework of GUI in this system by investigating existing tools and technologies. Based on our proposal, we implemented two applications for two cases in different domains, which have been described in detail in Case Study A and B. This section discusses the system structure, technical issues, and limitations of these two applications.

Table 6.5 compares two applications from the perspective of system structure. On the Repository Layer and the Control Layer, two applications do not show much difference. For the Presentation Layer, the AI-SAR application uses a web-based realtime map interface to display data and interact with users. In contrast, the Smart Building application utilizes a more diverse web GUI, on which a 3D outdoor map, a 2D indoor map, and a dashboard module for sensor data are deployed. The difference in the Presentation Layer shows the scalability of our proposed architecture. Similarly, for two applications, the subsystems used to provide decision support are completely different. However, since the internal cooperation of systems is based on data flow, it is straightforward to apply different subsystems to this structure, which also shows the flexibility of this architecture.

For our applications, we need two map-based GUIs to display the information users need. In the previous section of the thesis, we have stated that the GUI of GIS is essentially a data visualization tool. According to our proposed development framework for GUI, all the data applications need to present can be divided into three categories. During the implementation of these two different applications, we have followed this framework. **Table 6.6** shows how we classified all the data that need to be displayed on different maps.

After we classified the required data, the construction of the maps has been guided by

Table 6.5: The comparison from the perspective of system structure.

Main features of the two target applications		
	AI-SAR Application	Smart Building Application
Repository Layer	Data Related to Search and Rescue	Data Related to Smart Building
Control Layer	Data Management Module	Data Management Module
Presentation Layer	A realtime map interface	A GUI with double-scale map and dashboard
Decision Support Subsystem	AI Support System	Indoor Environmental Quality Analyzer

Table 6.6: The comparison of required data in two applications.

	AI-SAR Application	Smart Building Application
	2D maritime map	3D outdoor map 2D indoor map
Mapping Data	Nautical mapping data	Data for outdoor mapping Data for indoor mapping
Environmental Data	Data about weather, temperature, wind-speed, air pressure, etc.	Data on sunlight in realtime Data on occupancy in buildings
Application Object Data	Data about ships, harbours, helicopters, etc.	Data related to buildings Data related to rooms

data visualization approaches. For each map canvas on applications' GUI, we deployed three map layers for three types of data. The maps on the GUI are able to display all received data since it has been classified and distributed to three data visualization modules for visualization. **Fig. 6.8** shows the comparison of the map canvas on the GUI in the two applications. The AI-SAR application has only one map on its GUI, and three data visualization modules display all relevant data through three map layers. For the Smart Building application, two map canvases have been generated for the outdoor map and the indoor map. data visualization modules visualize both data from outdoor and indoor on the GUI. This comparison suggests that the proposed development framework can be tailored to different practical situations and needs: it is applicable to no matter a single-

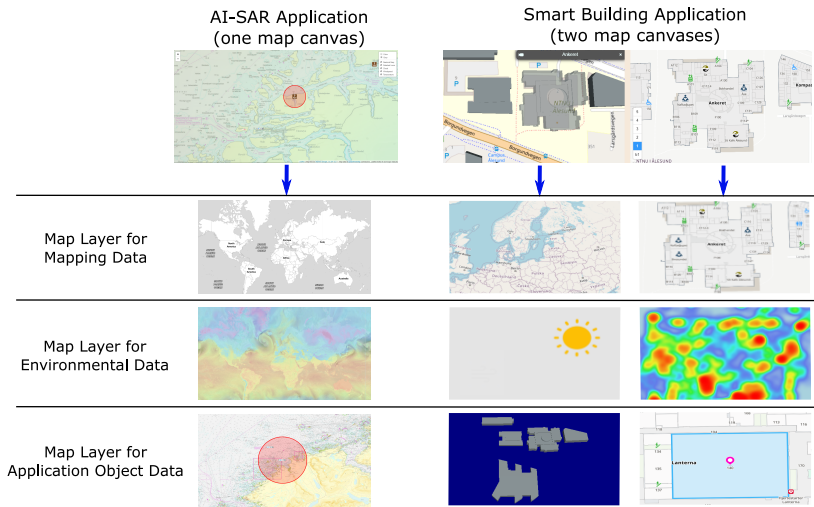

Figure 6.8: Each map canvas has three map layers for corresponding visualization.

map interface or a multi-map interface; it is applicable to no matter the large scale such as global size or small scale inside several buildings.

During the implementation of applications, we realized some limitations with our study, which will be discussed as follows.

For the application of AI-SAR, an apparent limitation is that it cannot provide historical data query function. Although we can simulate the historical moving track of an object on the map (such as the historical operation of a helicopter), it is not possible to retrieve all data related to a past timestamp. For example, users cannot query the historical weather conditions in a specific location or locate a target object at a particular timestamp in the past. This limitation is mainly due to the fact that the library LeafletJS we mainly use in this application does not provide an original timeline function. Besides, we did not collect enough historical data for testing. We believe that this limitation can be resolved as the work moves deeper.

One limitation of the Smart Building application is that the GUI does not provide many environmental data, which may have an impact on the decision-making support. On the outdoor map, we only simulated sunlight as an environmental factor. We did not collect some important data around the buildings (e.g., noise, air pressure, weather information in this area). At the same time, the occupancy was regarded as the only environmental factor on the indoor map. The lack of sufficient environmental data may affect the users' judgment of the building or room condition.

Conclusion and Future Work

This chapter presents the conclusion of this thesis in **Section 7.1** and discusses potential future work in **Section 7.2**.

7.1 Conclusion

The cooperation between GIS and complex decision support systems is a trend, while traditional GIS usually lacks compatibility with decision support systems. We introduced a modified architecture that can effectively combine GIS with the decision support system. In addition, we also proposed a development framework for the user interface based on this architecture. After that, two case studies were conducted to prove the feasibility of our proposal.

Four research questions that have guided the research in this thesis are answered after our investigation:

- **RQ1:** How to propose a generic architecture of GIS that could be compatible with complex decision support systems?

In **Chapter 3**, we proposed the architecture of GIS for decision support, which is modified based on the well-known three-layer architecture. The proposed architecture comprises four components: the Presentation Layer, the Control Layer, the Repository Layer, and the Decision Support Subsystem. Separating the system into multiple components makes it possible to scale one particular component at any time according to new requirements. In this architecture, each of the three layers is independent of each other, so that the modification or testing of each layer do not affect other layers' normal functions, which makes the development and maintenance of such a system more straightforward. Besides, the component used for complex decision-making analysis and support is regarded as a subsystem in this architecture. It is independent of the remaining components and communicates with other system components through data flow, which guarantees the extensibility and flexibility of decision support function.

- **RQ2:** How to propose a development framework for the user interface of such a system?

We believe that all the data that GIS for decision support displays on the user interface can be divided into three categories: the mapping data, the environmental data, and the application object data. From the perspective of data visualization, we proposed a development framework for the user interface of such a system in **Chapter 3**. Three data visualization modules deployed on the Presentation Layer are in charge of visualizing processed data from the system on GUI. Another module for controlling is responsible for coordinating the visualization content based on the request and operation of users. The GUI based on this framework can display information in a structured way, ensuring that the GUI is more precise and friendly to users. The process of data processing and transformation in such a system is also simplified because the data is visualized in categories by different visualization modules.

- **RQ3:** Is it possible to develop applications based on the proposed system architecture and user interface framework?

We investigated two case studies that were described in **Chapter 4** and **Chapter 5**, respectively. Two applications have been designed and developed based on the proposed system architecture and user interface framework: one application with a single-scale map interface for AI-SAR and one application with a double-scale map interface for Smart Building. The implementation of two applications has validated the feasibility of proposed architecture and framework.

- **RQ4:** Would the applications based on the proposed system architecture and user interface framework be usable for users?

We conducted an evaluation experiment for the application for Smart Building and illustrated the evaluation result in **Chapter 6**. We obtained positive results by analyzing the evaluation experiment data, which suggests a high usability of the application.

7.2 Future Work

In this thesis, we proposed some concepts and proved the feasibility of our concepts through application and evaluation. At the same time, we also identify rooms for improvement and advancement. This section discusses some possible directions for future work.

One potential work is about the other two layers of the system except for the Presentation Layer. Considering the importance of the user interface in an information system, we have partially proposed a development framework for the GUI of the entire system. We did not suggest a framework to guide the development of the Control Layer and the Repository Layer. During the implementation of the two applications in Case Study A and Case Study B, we used a relatively rough approach to develop the Control Layer and the Repository Layer. We believe that a generic and effective development framework for these two layers would be important to simplify the development process and improve sys-

tem performance. Therefore, the research on the development framework of the Control Layer and the Repository Layer could be a possible future work.

We believe that we still need to make further efforts to improve the two developed GIS for decision support. For the application for Smart Building, we received much valuable feedback from the evaluation volunteers, which can lead us to improve this application. In the future, we hope to conduct another evaluation experiment to obtain suggestions and comments from experts in the SAR field, so that the application for AI-SAR can be improved according to the professional feedback.

Completing a complex decision support system requires the support of sophisticated modeling, professional knowledge, and relevant techniques. In our research, we just adopted simple decision support subsystems to validate the proposed system architecture. One possible future work could concern the development of a complex decision support system for a specific case and applying this decision support system to the GIS built based on the proposed architecture. After that, the efficiency and effectiveness of this GIS should be tested in a practical application.

The introduction of AR and VR on the GUI is considered to be a future GIS trend. We believe that relevant research is worthy of attention. The research on the GUI with AR and VR extensions also would be one of our future exploration directions.

Bibliography

- Alesheikh, A.A., Helali, H., Behroz, H., 2002. Web gis: technologies and its applications, in: Symposium on geospatial theory, processing and applications.
- Alhamwi, A., Medjroubi, W., Vogt, T., Agert, C., 2017. Gis-based urban energy systems models and tools: Introducing a model for the optimisation of flexibilisation technologies in urban areas. *Applied Energy* 191, 1–9.
- Arnott, D., 2004. Decision support systems evolution: framework, case study and research agenda. *European Journal of Information Systems* 13, 247–259.
- Aronica, S., Benvegna, F., Cossentino, M., Gaglio, S., Langiu, A., Lodato, C., Lopes, S., Maniscalco, U., Sangiorgi, P., 2010. An agent-based system for maritime search and rescue operations. *CEUR Workshop Proceedings* 621.
- Bakhshipour, M., Ghadi, M.J., Namdari, F., 2017. Swarm robotics search & rescue: A novel artificial intelligence-inspired optimization approach. *Applied Soft Computing* 57, 708–726.
- Baryannis, G., Dani, S., Validi, S., Antoniou, G., 2019. *Decision Support Systems and Artificial Intelligence in Supply Chain Risk Management*. Springer International Publishing, Cham. pp. 53–71.
- Bashir, M.R., Gill, A.Q., 2016. Towards an IoT big data analytics framework: Smart buildings systems, in: 2016 IEEE 18th International Conference on High Performance Computing and Communications; IEEE 14th International Conference on Smart City; IEEE 2nd International Conference on Data Science and Systems (HPCC/SmartCity/DSS), pp. 1325–1332.
- Biczok, G., Martínez, S.D., Jelle, T., Krogstie, J., 2014. Navigating mazemap: indoor human mobility, spatio-logical ties and future potential, in: 2014 IEEE International Conference on Pervasive Computing and Communication Workshops (PERCOM WORKSHOPS), IEEE. pp. 266–271.

-
- Bock, A., Kleiner, A., Lundberg, J., Ropinski, T., 2014. An interactive visualization system for urban search rescue mission planning, in: 2014 IEEE International Symposium on Safety, Security, and Rescue Robotics (2014), pp. 1–7.
- Burrough, P., 1986. Principles of geographical information systems for land resources assessment. *Geocarto International* 1, 54–54.
- Caplan, J.M., Kennedy, L.W., Miller, J., 2011. Risk terrain modeling: Brokering criminological theory and GIS methods for crime forecasting. *Justice Quarterly* 28, 360–381.
- Chainey, S., Ratcliffe, J., 2013. GIS and crime mapping. John Wiley & Sons.
- Chang, K.T., 2016. Geographic information system. *International Encyclopedia of Geography: People, the Earth, Environment and Technology* , 1–10.
- Crossland, M.D., 2008. Decision-Making Effectiveness with GIS. Springer US, Boston, MA. pp. 232–235.
- Deng, Y., Cheng, J.C., Anumba, C., 2016. A framework for 3d traffic noise mapping using data from bim and gis integration. *Structure and Infrastructure Engineering* 12, 1267–1280.
- Di Paolantonio, M., Fernández, C.G., Latorre, M.J., Pedrera, F., García, A.R.P., 2015. 3D virtual representation of drones' flights through cesium. js and oculus rift. .
- Doraiswamy, H., Freire, J., Lage, M., Miranda, F., Silva, C., 2018. Spatio-temporal urban data analysis: A visual analytics perspective. *IEEE computer graphics and applications* 38, 26–35.
- Dorman, M., 2020. Introduction to Web Mapping. CRC Press.
- Dueker, K., 1979. Land resource information systems: A review of fifteen years experience. *Geo-Processing* 1, 105–128.
- Durieux, L., Lagabrielle, E., Nelson, A., 2008. A method for monitoring building construction in urban sprawl areas using object-based analysis of spot 5 images and existing gis data. *ISPRS Journal of Photogrammetry and Remote Sensing* 63, 399–408.
- Edler, D., Vetter, M., 2019. The simplicity of modern audiovisual web cartography: An example with the open-source javascript library leaflet. js. *KN-Journal of Cartography and Geographic Information* 69, 51–62.
- Egenhofer, M.J., Clarke, K.C., Gao, S., Quesnot, T., Franklin, W.R., Yuan, M., Coleman, D., 2016. Contributions of giscience over the past twenty years. *Advancing geographic information science: The past and the next twenty years* , 9–34.
- Eini, R., Linkous, L., Zohrabi, N., Abdelwahed, S., 2019. A testbed for a smart building: design and implementation, in: *Proceedings of the Fourth Workshop on International Science of Smart City Operations and Platforms Engineering*, pp. 1–6.

-
- Farkas, G., 2017. Applicability of open-source web mapping libraries for building massive web gis clients. *Journal of Geographical Systems* 19, 273–295.
- Ferguson, D., 2008. GIS for wilderness search and rescue, in: *Proceedings of ESRI Federal User Conference*.
- Ferreira, N., Lage, M., Doraiswamy, H., Vo, H., Wilson, L., Werner, H., Park, M., Silva, C., 2015. Urbane: A 3d framework to support data driven decision making in urban development, in: *2015 IEEE conference on visual analytics science and technology (VAST)*, IEEE. pp. 97–104.
- Fleming, S., Jordan, T., Madden, M., Usery, E., Welch, R., 2009. GIS applications for military operations in coastal zones. *ISPRS Journal of Photogrammetry and Remote Sensing* 64, 213–222.
- Gaber, H., Amin, S., M.Salem, A.B., 2011. Geospatial multi-agent system for urban search and rescue, in: *Proceedings of the 15th WSEAS international conference on Computers*, pp. 76–81.
- Gaikwad, S.V., Vibhute, A.D., Kale, K.V., Nalawade, D.B., Jadhav, M.B., 2018. Design and development of ground truth collection platform using android and leaflet library, in: *International Conference on Recent Trends in Image Processing and Pattern Recognition*, Springer. pp. 520–528.
- Govindaraj, S., Chintamani, K., Gancet, J., Letier, P., van Lierde, B., Nevatia, Y., De Cubber, G., Serrano, D., Esbri Palomares, M., Bedkowski, J., Armbrust, C., Sanchez, J., Coelho, A., Orbe, I., 2013. The ICARUS project - command, control and intelligence (C2I), in: *2013 IEEE International Symposium on Safety, Security, and Rescue Robotics (SSRR)*, pp. 1–4.
- Gutbell, R., Pandikow, L., Kuijper, A., 2018. Web-based visualization component for geo-information, in: *International Conference on Human Interface and the Management of Information*, Springer. pp. 23–35.
- He, B., Mo, W.x., Hu, J.x., Yang, G., Lu, G.j., Liu, Y.q., 2016. Development of power grid Web3D GIS based on Cesium, in: *2016 IEEE PES Asia-Pacific Power and Energy Engineering Conference (APPEEC)*, IEEE. pp. 2465–2469.
- Hu, S., Dai, T., 2013. Online map application development using Google Maps API, SQL database, and ASP .NET. *International Journal of Information and Communication Technology Research* 3.
- Hua, Y., Göçer, Ö., Göçer, K., 2014. Spatial mapping of occupant satisfaction and indoor environment quality in a leed platinum campus building. *Building and Environment* 79, 124–137.
- Huang, Q., Mao, C., 2017. Occupancy estimation in smart building using hybrid CO2/light wireless sensor network. *Journal of Applied Sciences and Arts* 1, 5.

-
- Kahila-Tani, M., Broberg, A., Kyttä, M., Tyger, T., 2016. Let the citizens map—public participation gis as a planning support system in the Helsinki master plan process. *Planning Practice & Research* 31, 195–214.
- Kang, X., Li, J., Fan, X., 2018. Spatial-temporal visualization and analysis of earth data under Cesium digital earth engine, in: *Proceedings of the 2018 2nd International Conference on Big Data and Internet of Things*, pp. 29–32.
- Kantosalo, A.A., Toivanen, J.M., Toivonen, H.T.T., et al., 2015. Interaction evaluation for human-computer co-creativity: A case study, in: *Proceedings of the sixth international conference on computational creativity*, Brigham Young University.
- Koyuncu, B., Özdemir, Z., 2016. Real time localization and leaflet map geofencing by using Sim900 based GPS/GSM/GPRS. *IFRSA International Journal Of Electronics Circuits And Systems* 5, 47–52.
- Larman, C., 2005. *Applying UML and Patterns: An Introduction to Object-Oriented Analysis and Design and Iterative Development*, 3rd Edition.
- Liao, G., Maofeng, L., 2010. SARGIS: A GIS-based decision-making support system for maritime search and rescue, pp. 1571–1574.
- Longley, P.A., Goodchild, M.F., Maguire, D.J., Rhind, D.W., 2015. *Geographic information science and systems*. John Wiley & Sons.
- Lü, G., Batty, M., Strobl, J., Lin, H., Zhu, A.X., Chen, M., 2019. Reflections and speculations on the progress in geographic information systems (GIS): a geographic perspective. *International Journal of Geographical Information Science* 33, 346–367.
- Lu, W., Ai, T., Zhang, X., He, Y., 2017. An interactive web mapping visualization of urban air quality monitoring data of China. *Atmosphere* 8, 148.
- Ludwigsdorff, N.v.F., Peters, S., Brügge, B., Loftness, V., Aziz, A., 2016. Effective visualization and control of the indoor environmental quality in smart buildings., in: *Software Engineering (Workshops)*, pp. 124–129.
- Maguire, D.J., 1991. An overview and definition of GIS. *Geographical information systems: Principles and applications* 1, 9–20.
- Mathiyalagan, V., Grunwald, S., Reddy, K., Bloom, S., 2005. A WebGIS and geodatabase for Florida’s wetlands. *Computers and electronics in agriculture* 47, 69–75.
- Merkert, J., Mueller, M., Hubl, M., 2015. A survey of the application of machine learning in decision support systems, in: *ECIS*.
- Mignard, C., Nicolle, C., 2014. Merging bim and gis using ontologies application to urban facility management in active3d. *Computers in Industry* 65, 1276–1290.
- Morvaj, B., Lugaric, L., Krajcar, S., 2011. Demonstrating smart buildings and smart grid features in a smart energy city, in: *Proceedings of the 2011 3rd International Youth Conference on Energetics (IYCE)*, pp. 1–8.

-
- Naidu, D.S., 2018. GIS applications to smart cities. *International Journal of Advanced Multidisciplinary Scientific Research (IJAMSR)* 1, 2.
- Neene, V., Kabemba, M., 2017. Development of a mobile GIS property mapping application using mobile cloud computing. *Development* 8, 57–68.
- Omidipour, M., Jelokhani-Niaraki, M., Moeinmehr, A., Sadeghi-Niaraki, A., Choi, S.M., 2019. A GIS-based decision support system for facilitating participatory urban renewal process. *Land Use Policy* 88, 104150.
- Orford, S., 2017. *Valuing the built environment: GIS and house price analysis*. Routledge.
- Peterson, M.P., 2012. Online mapping with APIs, in: *Online maps with APIs and web-services*. Springer, pp. 3–12.
- Pinto-Cáceres, S.M., Almeida, J., Baranauskas, M.C.C., Torres, R.d.S., 2015. Fisir: a flexible framework for interactive search in image retrieval systems, in: *International Conference on Multimedia Modeling*, Springer. pp. 335–347.
- Pinto-Cáceres, S.M., Almeida, J., Neris, V.P., Baranauskas, M.C.C., Leite, N.J., Torres, R.d.S., 2011. Navigating through video stories using clustering sets. *International Journal of Multimedia Data Engineering and Management (IJMDEM)* 2, 1–20.
- Pitman, S.J., Wright, M., Hocken, R., 2019. An analysis of lifejacket wear, environmental factors, and casualty activity on marine accident fatality rates. *Safety science* 111, 234–242.
- Plageras, A.P., Psannis, K.E., Stergiou, C., Wang, H., Gupta, B.B., 2018. Efficient IoT-based sensor Big Data collection–processing and analysis in smart buildings. *Future Generation Computer Systems* 82, 349–357.
- Preece, J., Rogers, Y., Sharp, H., 2002. *Interaction design*. John Wiley & Sons.
- Rikalovic, A., Cosic, I., Labati, R.D., Piuri, V., 2017. Intelligent decision support system for industrial site classification: A GIS-based hierarchical neuro-fuzzy approach. *IEEE Systems Journal* 12, 2970–2981.
- Rossmo, D.K., Velarde, L., Mahood, T., 2019. Optimizing wilderness search and rescue: A bayesian gis analysis. *ISSN 2230-5734 JournalofSAR. com* 3, 44.
- Roth, R.E., Donohue, R.G., Sack, C.M., Wallace, T.R., Buckingham, T.M., 2014. A process for keeping pace with evolving web mapping technologies. *Cartographic Perspectives* , 25–52.
- Safdar, S., Zafar, S., Zafar, N., Khan, N.F., 2018. Machine learning based decision support systems (DSS) for heart disease diagnosis: a review. *Artificial Intelligence Review* 50, 597–623.
- Schwee, J.H., Johansen, A., Jørgensen, B.N., Kjærgaard, M.B., Mattera, C.G., Sangogboye, F.C., Veje, C., 2019. Room-level occupant counts and environmental quality from heterogeneous sensing modalities in a smart building. *Scientific data* 6, 1–11.

-
- Shim, J.P., Warkentin, M., Courtney, J.F., Power, D.J., Sharda, R., Carlsson, C., 2002. Past, present, and future of decision support technology. *Decision support systems* 33, 111–126.
- Siljander, M., Venäläinen, E., Goerlandt, F., Pellikka, P., 2015. GIS-based cost distance modelling to support strategic maritime search and rescue planning: A feasibility study. *Applied Geography* 57, 54–70.
- Šterk, M., Praprotnik, M., 2017. Improving emergency response logistics through advanced GIS. *Open Geospatial Data, Software and Standards* 2, 1–6.
- Teslya, N., 2014. Web mapping service for mobile tourist guide, in: *Proceedings of 15th Conference of Open Innovations Association FRUCT, IEEE*. pp. 135–143.
- Tsai, F., Lai, J.S., Liu, Y.C., 2016. An alternative open source web-based 3D GIS: Cesium engine environment, in: *Asian Conference on Remote Sensing: Fostering Resilient Growth in Asia*, Citeseer.
- Ulmke, M., Koch, W., 2006. Road-map assisted ground moving target tracking. *IEEE transactions on Aerospace and Electronic Systems* 42, 1264–1274.
- Varlamis, I., Tserpes, K., Sardianos, C., 2018. Detecting search and rescue missions from AIS data, in: *2018 IEEE 34th International Conference on Data Engineering Workshops (ICDEW)*, IEEE. pp. 60–65.
- Yamamura, S., Fan, L., Suzuki, Y., 2017. Assessment of urban energy performance through integration of BIM and GIS for smart city planning. *Procedia engineering* 180, 1462–1472.
- Yang, K., Li, Y.q., Xu, Q.l., Peng, S., Cao, Y., 2006. Design of earthquake emergency response decision support systems based on ArcGIS. *Journal of Seismological Research* 29, 203–208.
- Yuan, M., 2017. 30 years of IJGIS: the changing landscape of geographical information science and the road ahead. *International Journal of Geographical Information Science* 31, 425–434.
- Zhou, X., Cheng, L., Min, K., Zuo, X., Yan, Z., Ruan, X., Chu, S., Li, M., 2020. A framework for assessing the capability of maritime search and rescue in the south china sea. *International journal of disaster risk reduction* , 101568.

