



Lene Engedal Bostad, Jarl Bernhard Berg Kjølseth

**NTNU**  
Norwegian University of  
Science and Technology  
Faculty of Engineering  
Department of Mechanical and Industrial Engineering

Lene Engedal Bostad  
Jarl Bernhard Berg Kjølseth

# A Stair Aid That Helps The Elderly With Stair Negotiation And Monitors Health Parameters

June 2020

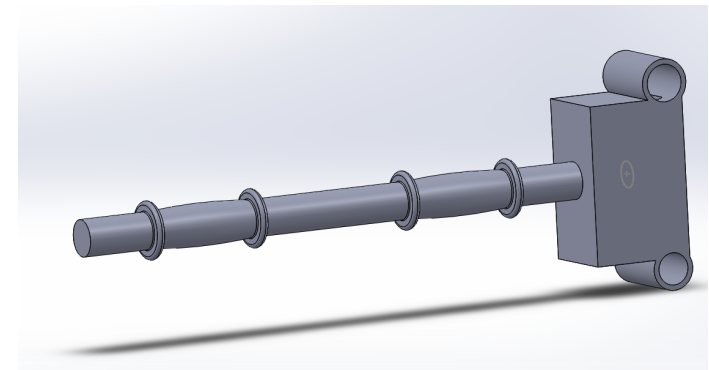





Norwegian University of  
Science and Technology

# A Stair Aid That Helps The Elderly With Stair Negotiation And Monitors Health Parameters

**Lene Engedal Bostad**

**Jarl Bernhard Berg Kjølseth**

Mechanical Engineering

Submission date: June 2020

Supervisor: Amund Skavhaug

Norwegian University of Science and Technology  
Department of Mechanical and Industrial Engineering



# Problem Description

Norway's population has an increasing amount of elderly people. It is a goal to have these people live in their own homes for as long as possible for economic reasons from society's perspective, and it is of interest to the elderly individuals themselves. To achieve this, welfare technology that facilitates independent living is needed.

The candidates shall present and investigate ideas and assumptions on how to facilitate a more independent life that allows the elderly individual to live at home longer (age in place). This can be made possible by assisting the negotiation of stairs and monitor health and activity so that emergency response and early intervention can be done if needed.

The work done by the candidates will be used to conclude whether or not these ideas are sufficiently promising to further develop their aid.

The candidates are expected to investigate the target group for such an aid, existing solutions available today, and how to differentiate from these. The work done by the candidates will consist of:

- Identify the potential need for an improved aid that elderly people can use to negotiate stairs, through investigation of existing solutions related to this thesis and relevant theory regarding the target group.
- Prototype, test and design potential solutions.
- Identify and work with various sensors and hardware that can be used to collect relevant data.
- Lay the foundation for an app that can be used to convey information about the elderly individual.
- Describe possible functionalities and tests that can reveal if added value is achieved.
- Based on the work done, conclude if enough promise has been shown for further development to be advised.

The subtasks needed to achieve this will be decided by the candidates during the work on the thesis.

# Summary

This thesis explores the ideas regarding an aid, henceforth called Safestep, that can help elderly people that have reduced mobility, with the negotiation of stairs, and monitor their health at the same time. For those who want it, this can facilitate a more independent life in their own home, for a longer period.

The target group and their needs have been investigated, and so has existing, similar solutions. Through this, the candidates have made assumptions on which functions Safestep should have. Functions such as detecting when a person falls, calling for emergency help when needed, assisting the negotiation of stairs, and monitoring vital signs. The candidates have also worked on how information collected by Safestep, which is regarded as relevant for the elderly person's health, can be conveyed to the next of kin or a health professional. Made possible without any action needed from the person being monitored. This is due to the possibility of early detection of deteriorating health or accidents. These functions have then been worked on through the use of prototypes, electronics, and app development. A possible design is presented, through strength analysis and a CAD model. Also, ways of testing and how further work on the development can be done is described. This can be used to validate or debunk the candidates' assumptions on what functions that can add value.

The conclusion is that Safestep could be a valuable aid for the elderly, and therefore the candidates advise further development of Safestep.

# Sammendrag

Denne avhandlingen utforsker ideer tilknyttet et hjelpemiddel, som heretter kalles Safestep, som kan hjelpe eldre folk som har redusert mobilitet, med å bruke trapper og overvåke helsen deres samtidig. For de som ønsker det, kan dette fasilitere et mer selvstendig liv i deres eget hjem, over en lenger periode enn ellers.

Målgruppen og deres behov har blitt undersøkt, det har og eksiterende, lignende løsninger. Gjennom dette har kandidatene gjort seg antagelser om hvilke funksjoner Safestep burde ha. Funksjoner som å oppdage fall, tilkalle nødhjelp når nødvendig, assistere bruk av trapp og overvåke vitale verdier. Kandidatene har og jobbet med hvordan informasjonen som Safestep samler, som anses som relevant for den eldre personen sin helse, kan bli videreført til nærmeste pårørende eller medisinsk personell. På en måte som ikke krever noe fra den eldre personen som overvåkes. Dette gjøres på grunn av muligheten for å fange opp tegn på en skrantende helse eller ulykker, så tidlig som mulig. Disse funksjonene har blitt jobbet med gjennom prototyping, elektronikk og app-utvikling. Et mulig design er presentert, gjennom styrkeberegninger og en CAD modell. I tillegg blir måter å teste og videreutvikle på, beskrevet. Dette kan så brukes for å validere eller avkrefte kandidatene sine antagelser angående hvilke funksjoner som kan gi merverdi.

Konklusjonen er at Safestep kan være et viktig hjelpemiddel for den eldre befolkningen, og av den grunn anbefaler kandidatene videre utvikling av Safestep.

# Preface

This project is motivated by the increasing need for welfare technology to maintain the quality of life of the elderly. Help with small obstacles in their everyday life can be just the little change needed for them to be able to manage themselves alone. To do this, the candidates have worked on developing an aid that can assist the elderly when negotiating the stairs. This aid would also monitor the health of the individual, so that early intervention is possible in the case of illnesses or accidents.

The report is based on a feasibility study around developing a product with added value with the use of mechatronics. Both authors of this report have a background with a wide range of engineering knowledge. Interest and knowledge in product development and mechatronics, combined with the desire to help someone gave the start to this project.



# Acknowledgement

The guidance of Amund Skavhaug has been a big help through his combined focus on the candidates themselves as well as the work done on the thesis. His knowledge and experience have been of great significance for two students navigating through unknown territory.

A big thanks to Astrid Kjølseth for her insight both as a retired nurse and as an elderly person using the stairs every day. She has contributed in seeing what sort of difficulties can occur when using the stairs and how stair negotiation might look like, an insight that would be challenging for two students to gain on their own.

The candidates would also like to thank Anja Murud Gahre for her help with the calculation of strength. The simulations of the deflection of the prototype done in Abaqus could not have been done without her.



# Table of Contents

<b>Problem description</b>	<b>i</b>
<b>Summary</b>	<b>ii</b>
<b>Sammendrag</b>	<b>iii</b>
<b>Preface</b>	<b>iv</b>
<b>Table of Contents</b>	<b>x</b>
<b>List of Tables</b>	<b>xi</b>
<b>List of Figures</b>	<b>xv</b>
<b>Abbreviations</b>	<b>xvi</b>
<b>1 Introduction</b>	<b>1</b>
1.1 SARS-CoV-2 outbreak . . . . .	1
1.2 Background and motivation . . . . .	1
1.3 Aim of this thesis . . . . .	3
1.4 Reading guidance . . . . .	3
<b>2 Monitoring</b>	<b>5</b>
2.1 What to monitor . . . . .	5
2.1.1 Vital signs . . . . .	6
2.1.2 Temperature . . . . .	6
2.1.3 Heart rate . . . . .	6
2.1.4 Motion . . . . .	6
2.2 Accepting being monitored . . . . .	7
2.2.1 Concerns . . . . .	7
2.2.2 Monitoring or surveillance? . . . . .	7
2.3 Privacy . . . . .	8

2.4	Existing solutions . . . . .	9
2.5	Discussion and Summary . . . . .	9
<b>3</b>	<b>Welfare Technology</b>	<b>11</b>
3.1	The different categories . . . . .	11
3.2	The rewards . . . . .	12
3.3	Discussion and summary . . . . .	12
<b>4</b>	<b>Ageing in place</b>	<b>13</b>
4.1	The daily life . . . . .	13
4.2	Demographics . . . . .	14
4.3	Financial view . . . . .	14
4.4	The individual's view . . . . .	14
4.5	Does a longer life implies more healthier years? . . . . .	15
4.5.1	Morbidity hypotheses . . . . .	15
4.6	Will the technology be accepted? . . . . .	15
4.7	Discussion and Summary . . . . .	16
<b>5</b>	<b>The physical activity of ascending and descending stairs</b>	<b>17</b>
5.1	One- or two-step negotiating . . . . .	17
5.1.1	Stairs for exercise . . . . .	18
5.2	Governmental advice . . . . .	18
5.3	Discussion and summary . . . . .	18
<b>6</b>	<b>Existing solutions</b>	<b>19</b>
6.1	Assistep . . . . .	19
6.2	Stairlifts . . . . .	20
6.3	StairSteady . . . . .	21
6.4	EZ-step . . . . .	22
6.5	Discussion and Summary . . . . .	23
<b>7</b>	<b>Ideas and prototypes</b>	<b>25</b>
7.1	The handle . . . . .	25
7.1.1	Idea . . . . .	25
7.1.2	Prototypes . . . . .	27
7.2	Brake system . . . . .	34
7.3	How to move Safestep along the banister . . . . .	34
7.3.1	Drum moving up and down cable . . . . .	34
7.3.2	Bicycle chain system . . . . .	36
7.3.3	Rack and pinion . . . . .	36
7.4	Iterations . . . . .	37
7.5	Discussion and summary . . . . .	37

<b>8</b>	<b>Design and calculations</b>	<b>41</b>
8.1	Design of handle . . . . .	41
8.2	Connection between banister and handle . . . . .	43
8.3	Banister . . . . .	49
8.4	Safety . . . . .	49
8.5	Proposed model . . . . .	49
8.6	Calculation of strength by hand . . . . .	50
8.7	Vulnerable points in the attachment . . . . .	54
8.8	Calculation of strength with Abaqus . . . . .	54
	8.8.1 Choice of material . . . . .	57
8.9	Discussion and summary . . . . .	58
<b>9</b>	<b>Sensors</b>	<b>59</b>
9.1	Temperature . . . . .	59
9.2	Heart rate . . . . .	60
9.3	Stair negotiation time . . . . .	61
<b>10</b>	<b>Technology and protocols worked with</b>	<b>63</b>
10.1	Pulse Width Modulation . . . . .	63
10.2	Motor driver . . . . .	64
10.3	DC motor . . . . .	66
10.4	I <sup>2</sup> C protocol . . . . .	68
10.5	UART . . . . .	68
10.6	Bluetooth protocol . . . . .	68
10.7	Summary . . . . .	70
<b>11</b>	<b>Hardware</b>	<b>71</b>
11.1	Arduino Nano . . . . .	71
11.2	Sparkfun Bluetooth Mate Silver . . . . .	73
11.3	DRV8871 motor driver . . . . .	74
11.4	Sparkfun single lead heart rate monitor . . . . .	74
11.5	Adafruit AMG8833 thermal camera . . . . .	77
11.6	LM35 temperature sensor . . . . .	77
11.7	Force-sensitive resistor . . . . .	79
11.8	Reed switch . . . . .	81
11.9	Energy system . . . . .	81
11.10	Discussion and summary . . . . .	82
<b>12</b>	<b>Suggested design of the total system</b>	<b>83</b>
12.1	Choosing the system . . . . .	85
12.2	How it works . . . . .	86
12.3	Detecting someone who falls . . . . .	87
12.4	The Motor class . . . . .	91
12.5	Stair negotiation time . . . . .	94
12.6	The combination . . . . .	96
	12.6.1 Heart rate monitor . . . . .	96

12.6.2	Thermal camera . . . . .	97
12.6.3	FSR . . . . .	97
12.6.4	LM35 temperature sensor . . . . .	98
12.7	Hook up guide . . . . .	99
12.8	Discussion and summary . . . . .	99
<b>13</b>	<b>App development</b>	<b>101</b>
13.1	Layout of the app . . . . .	104
13.2	Programming language . . . . .	111
13.3	Code . . . . .	111
<b>14</b>	<b>Possible functionalities to implement and tests that can be performed</b>	<b>117</b>
14.1	How to monitor activity level . . . . .	118
14.2	Erroneous statistics . . . . .	121
14.3	Test each individual sensor to collect data as best as possible . . . . .	122
14.3.1	Heart rate monitor . . . . .	122
14.3.2	Test of Reed switch . . . . .	124
14.3.3	LM35 and thermal camera-AMG8833 . . . . .	125
14.3.4	Test of FSR . . . . .	128
14.4	Average values . . . . .	129
14.5	Include more sensors in detecting falls . . . . .	130
14.6	Test of the complete system . . . . .	133
14.6.1	Sensors . . . . .	133
14.6.2	Motor . . . . .	134
14.7	Communication . . . . .	135
14.8	Observing target group . . . . .	136
14.9	Discussion and summary . . . . .	137
<b>15</b>	<b>Discussion</b>	<b>139</b>
15.1	A marked for Safestep . . . . .	139
15.2	Monitoring . . . . .	141
15.3	App . . . . .	142
15.4	Design . . . . .	143
15.5	Possible functionalities and tests . . . . .	144
15.6	The need for Safestep . . . . .	146
<b>16</b>	<b>Further work</b>	<b>149</b>
<b>17</b>	<b>Conclusion</b>	<b>153</b>
	<b>Bibliography</b>	<b>155</b>
	<b>Appendix A</b>	<b>163</b>
	<b>Appendix B</b>	<b>165</b>

# List of Tables

9.1	Possible sensors/technology to use with Safestep . . . . .	59
14.1	Temperature values that 99% of the population falls within, heart rate range covering resting heart rate and rate under some strain, time is based on an estimate done by the authors on how long it can take to walk a 16 steps staircase. . . . .	121





# List of Figures

1.1	The elderly population in Norway today[3]	2
1.2	Expected numbers for the elderly population in Norway in the year 2060[3]	2
6.1	assistep	20
6.2	Stannah stairlift	21
6.3	StairSteady	22
6.4	EZ-step	23
7.1	Pictures of different handles on walkers	26
7.2	Pictures of handles on stroller and shopping cart	26
7.3	Handles from bicycles	27
7.4	Paper roll simulating Safestep handles	28
7.5	Handle across the direction of movement	29
7.6	How the upper body was angled	30
7.7	Handle made in play doh	31
7.8	Plastic bottle with sensors	32
7.9	Plastic bottle with sensors	33
7.10	Illustration of the forward motion system with drum and cable	35
7.11	Rolling bicycle chain on the banister	36
7.12	Rack and pinion [58]	37
7.13	Safestep in the stairs	39
8.1	The contact surface of the hand	42
8.2	Prototype of handle	43
8.3	Rack and pinion [58]	44
8.4	Example one of a sketch of the connection	45
8.5	Example two of a sketch of the connection	46
8.6	Example three of a sketch of the connection	47
8.7	Example four of a sketch of the connection	48
8.8	Model of Safestep	50
8.9	Cantilevered beam	51

8.10	Torque . . . . .	52
8.11	Outer and inner diameter . . . . .	52
8.12	Deflection . . . . .	54
8.13	Weak points in the attachment mechanism . . . . .	55
8.14	Scale of yield stress . . . . .	56
8.15	Strength analysis Side view . . . . .	56
8.16	Strength analysis Bottom view . . . . .	57
8.17	Strength analysis ISO view . . . . .	57
9.1	An ECG graph [65] . . . . .	61
10.1	Examples of different duty cycles with PWM [69] . . . . .	64
10.2	H-bridge configuration [70] . . . . .	65
10.3	Combination of microcontroller, motor driver and DC motor [71] . . . . .	66
10.4	Force applied to shaft [73] . . . . .	67
10.5	Forces when inclined surface [73] . . . . .	67
10.6	Serial communication using wires and using Bluetooth [77] . . . . .	69
11.1	Pinout of the Arduino Nano [84] . . . . .	72
11.2	The Sparkfun Bluetooth Mate Silver [86] . . . . .	73
11.3	The DRV8871 motor driver [88] . . . . .	74
11.4	The Sparkfun single lead heart rate monitor [90] . . . . .	75
11.5	The cardiac monitor configuration used by Sparkfun [91] . . . . .	75
11.6	Circuit for heart rate measurement at hands [92] . . . . .	76
11.7	The IR camera from Adafruit [94] . . . . .	77
11.8	Accuracy is how close the returned value is to the real value. Precision is how close the returned values are to each other over time [97] . . . . .	78
11.9	The LM35 from Texas Instruments [61] . . . . .	78
11.10	A square force sensitive resistor [98] . . . . .	79
11.11	Force vs. resistance [99] . . . . .	80
11.12	Change in output voltage with change in force due to different voltage divider circuits [100] . . . . .	80
11.13	Reed switch [66] . . . . .	81
12.1	Safestep . . . . .	84
12.2	The suggested system for safestep . . . . .	85
12.3	Diagram illustrating the system controlling Safestep . . . . .	86
12.4	Flow chart for how to detect if someone is walking in the stairs . . . . .	88
12.5	Image shows the <i>is_walking()</i> function . . . . .	89
12.6	Flow chart for how falling is detected . . . . .	90
12.7	Image shows code that checks if someone has fallen . . . . .	91
12.8	Image from the .h file for motor control . . . . .	91
12.9	Image from the .cpp file of the <i>Motor</i> class . . . . .	92
12.10	Diagram illustrating code for setup and loop function for motor control . . . . .	93
12.11	loop function that measures stair negotiation time . . . . .	94
12.12	Diagram illustrating the code that measures stair negotiation time . . . . .	95

12.13	Diagram illustrating use of the EKG . . . . .	96
12.14	Diagram illustrating the use of the IR camera . . . . .	97
12.15	Diagram illustrating the use of FSR . . . . .	98
12.16	Interaction between a person, the Lm35 and the Arduino . . . . .	98
12.17	How the components were connected . . . . .	99
13.1	Safestep communicating with the Safestep app . . . . .	101
13.2	Communication from Safestep to app . . . . .	102
13.3	Are you feeling well? . . . . .	103
13.4	Schematics of the app . . . . .	105
13.5	Information page, Pulse . . . . .	106
13.6	Frontpage . . . . .	107
13.7	Login . . . . .	108
13.8	Temperature, Pulse and Walking speed . . . . .	109
13.9	Example of App design . . . . .	110
13.10	Show temperature information in the app . . . . .	111
13.11	When the app is opened . . . . .	112
13.12	After a set time . . . . .	113
13.13	Creating global variables . . . . .	113
13.14	When the login or register button is clicked . . . . .	114
13.15	Procedure verify the user . . . . .	115
13.16	Function, when Firebase got value . . . . .	115
13.17	Procedure, activate the user . . . . .	115
13.18	Function, when Firebase tag list . . . . .	116
14.1	Safestep with what it monitors and the Safestep app . . . . .	118
14.2	Diagram illustrating how the activity could be monitored . . . . .	120
14.3	Diagram for checking sensor values . . . . .	122
14.4	How to collect heart rate from an ECG . . . . .	123
14.5	Possible ways someone might hold on to Safestep . . . . .	124
14.6	Testing reaction height for magnet . . . . .	125
14.7	Testing speed . . . . .	125
14.8	How to identify correct temperature readings . . . . .	127
14.9	Illustration showing the lowering of the rubber handle around the area where the FSR is located . . . . .	129
14.10	Flowchart for calculating average sensor values . . . . .	130
14.11	Flowchart showing how falling can be detected using the heart rate sensor . . . . .	131
14.12	Flowchart showing how falling can be detected using the thermal camera and checking is someone is walking . . . . .	132
14.13	Picture of where the different sensors could be placed . . . . .	133
14.14	Picture of where the different sensors could be placed . . . . .	134
14.15	Flowchart demonstrating communication with a possible fallen person . . . . .	136
17.1	Showing specification in the analysis . . . . .	163
17.2	Abaqus standard analysis with use of quadratic tetrahedron mesh . . . . .	164

# Abbreviations

DC	=	Direct current
ECG	=	Electrocardiogram
IC	=	integrated circuit
I <sup>2</sup> C	=	Inter-integrated circuit
PA	=	Physical activity
PCB	=	Printed circuit board
PWM	=	Pulse width modulation
SIG	=	Special interest group
SNT	=	Stair negotiation time
SPP	=	Serial port profile
SSP	=	Secure simple pairing
UART	=	Universal asynchronous receiver transmitter

# Chapter 1

## Introduction

For simplicity, the product that could be developed based on this report will be referred to as Safestep throughout the report.

### 1.1 SARS-CoV-2 outbreak

The work done during this thesis was affected by the SARS-CoV-2 pandemic. The aim of the thesis had to be adjusted, and what had been a more practical focus needed to shift towards a more theoretical one. This was at a time when the candidates were well on their way with their work. This is also reflected in a problem description that needed to be altered when it became apparent that access to school grounds would most likely not be granted. The cooperation between the authors and between their supervisor had to adapt to digital communication. The combination of these had an impact on how work had to be performed. The testing and prototyping of Safestep were greatly affected, without access to the university's facilities. Therefore, this part is mainly described theoretically how it would, and can, be done. This is work considered necessary by the authors to further develop Safestep. Therefore it should be performed in practice to verify/disprove the assumptions that lead up to the tests, and it can help to reveal further aspects not thought of by the authors.

### 1.2 Background and motivation

In Norway, 81000 people over the age of 66 reside on the first floor or higher without access to an elevator [1]. With old age comes challenges regarding mobility, increased likelihood of injuries associated with falling, and an increased need for assistance [2]. This is a challenge and will be an even bigger challenge in the future as the older population grows as seen in Figure 1.1 and Figure 1.2. The difference of the population in 2019 and the expected population of the elderly people in 2060.

11667: Framskrevet folkemengde 1. januar, etter kjønn og alder. Hele befolkningen, Hovedalternativet (MMMM), Folkemengde, 2019.

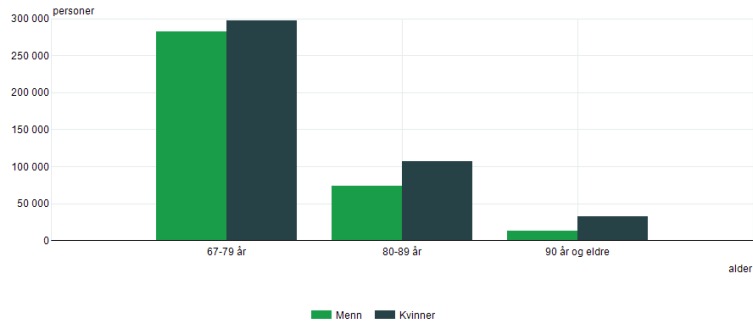

Kilde: Statistisk sentralbyrå

**Figure 1.1:** The elderly population in Norway today[3]

11667: Framskrevet folkemengde 1. januar, etter kjønn og alder. Hovedalternativet (MMMM), Folkemengde, 2060.

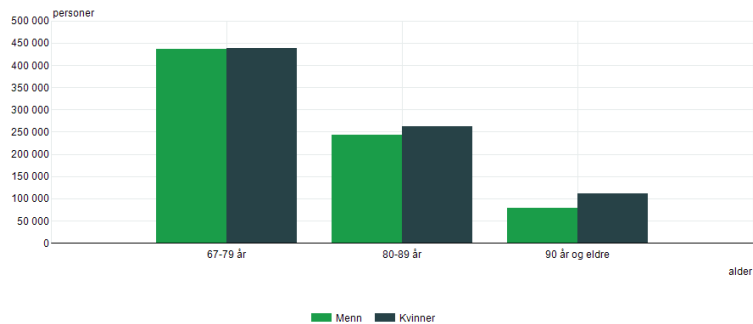

Kilde: Statistisk sentralbyrå

**Figure 1.2:** Expected numbers for the elderly population in Norway in the year 2060[3]

The use of technology to help the elderly people will make it possible to free resources such as care facilities and health care workers and to put it/them to use where it is most needed. This will also give the elderly the possibility to stay in their homes as long as possible and make them as independent as possible. It can also benefit a recipient of assistance by allowing the assistant to focus more on socialising and other interpersonal aspects. This can improve the general well-being of an elderly person, as it is reported that loneliness is a possible consequence of deteriorating health due to old age [4].

Using mechatronics and other technology to try to solve health challenges gives motivation. Working with a professional field one is interested in and be able to help someone getting an easier everyday life.

Another part of the motivation comes from the desire to help not just any senior, but older in the author's families especially grandparents. They are right at that age getting more and more need for assistance in the things they do. Next to the need for assistance,

elderly people can be stubborn regarding being able to handle oneself and the desire to live as long as possible at home. They do not want to be a bother for anyone, but they know they might need assistance. Getting assistance when ascending and descending stairs from a device made with electronics can, therefore, be helpful and give motivation to find some smart solutions. <sup>1</sup>

### **1.3 Aim of this thesis**

The target group for Safestep is elderly people, meaning people aged 67 and more, with reduced mobility, but otherwise capable of taking care of themselves.

It is Norwegian policy to move away from institutionalised care and instead facilitate for people to live at home for longer [6], Safestep shall facilitate this for those who desire it.

This thesis aims to investigate the need for, and then develop, a new aid to help elderly people to stay at home for as long as possible by assisting and monitoring stair negotiation. Due to changes that had to be made during the semester, a large part of this thesis focuses on laying the foundation for further development.

Once the need has been established, the work will consist of developing and describing intended functionalities, necessary components, design, and an app used for communication with health personnel and next of kin. There will also be descriptions on how and why further development can be done by testing functions and prototypes to see if value is added.

By combining knowledge about the target group and their situation with the author's technological background, assumptions are to be made about what could add value. These assumptions will then either be verified or disproved through the development of Safestep.

### **1.4 Reading guidance**

This thesis is written for people with a background in technology and professionals within the area of medicine. There will be given adequate explanations on unfamiliar subjects for both disciplines to understand. The paper focuses on the technical issues around Safestep together with the process of product development, because of the background of the authors.

Safestep is an envisaged product for stair negotiation and monitoring of health for elderly people for them to live at home for longer. In this thesis, the development of a health monitoring system, design, and an app for the use of Safestep is discussed. It is important to emphasize the added value of the different functionality of Safestep. This gives the answer to what a prototype should contain and what functions on Safestep worth continue working on.

In this thesis, the common organizational structure, IMRAD, has not been used. Developing a product will have several sub-topics that will be natural to present separately. Ideas and practical solutions will be presented gradually through the thesis, which make

---

<sup>1</sup>This section is partly taken from one of the candidate's previous work on Safestep [5], with adjustments to fit the thesis better.

IMRAD inexpedient to apply. Also, the IMRAD structure was advised by the candidate's supervisor to not be used in this thesis.

Chapter 2 to chapter 6 covers background material regarding a target group for Safestep. This includes welfare technology and existing solutions that assist in stair negotiation and monitor health. Chapter 7 and chapter 8 is about the work done on ideas and prototypes used in this thesis. Calculations on a proposed design related to what forces could be involved, which is used to suggest a material to produce Safestep in. Chapter 9 to chapter 11 contains background material regarding the types of sensors and other hardware that could be suited, and what components that were worked on by the candidates. Chapter 13 describes how an app could work, and how the candidates have worked on developing it. Chapter 12 and chapter 14 is about a suggested complete system for Safestep. They cover the parts that the candidates were able to implement and parts that were planned to implement, but instead had to be described theoretically. Finally, chapter 15 to chapter 17 covers the discussion regarding the work and results from the thesis and suggested further work.

Where it is appropriate, a discussion is included at the end of the chapter. This is because of the interdisciplinary characteristics of the thesis. For readability, it is easier to discuss the aspects at the end of the chapter where it is natural. A broader discussion is collected at the end in chapter 15.

Because of dealing with a potential new product, the candidates have included some drawings they have done by hand. Sketches like those are a common tool at the start of product development and strengthen creativity. Including the drawings in the paper will give the reader a better understanding.



# Monitoring

With the use of different sensors, it is possible to gather data that could be of significance to a person's health and well-being. By monitoring daily activities it could be possible to detect deviations from normal behaviour, and use this to identify possible causes.

If monitoring is done in someone's home, it could be perceived as an intrusion. The person being monitored should have ownership of the data, decide for him/herself who has access to it, and be informed of how it will be used. This chapter will look into the possible ways data can be collected when a person uses the stairs, what this can be used for and what information of value to the person's health can be gathered <sup>1</sup>.

## 2.1 What to monitor

With the target group for Safestep being the elderly, and the location is the staircase, you have a situation that most often looks the same (either the person walks up or down) and the time the situation lasts is longer than with a younger individual who does not need any assistance. This makes for good circumstances to do monitoring, and easier to detect abnormal behaviour like falling.

There are many different things possible to monitor that could be of interest regarding an elderly person's well-being. Weight, body temperature, blood pressure, tremors, and heart rate are parameters that can be used to assess the health situation. Time spent negotiating stairs, time spent sitting or lying, social interaction, eating and sleeping can be used more indirectly to assess the situation, for example by monitoring the changes over time as a possible indicator of decline. With the aim of developing an aid used in the stairs, what to monitor will be limited by the surroundings and the author's judgement of what fits best with Safestep. Other things could be monitored as well, that however, would be investigated further in a possible extension of the product at a later time.

---

<sup>1</sup>This chapter is taken from one of the candidate's previous work on Safestep [5], with adjustments to fit the thesis better.

### **2.1.1 Vital signs**

”Vital signs are objective measures of physiological function that are used to monitor acute and chronic disease and thus serve as a basic communication tool about patient status” [7]. Vital signs can be affected by physiological and pathological changes as a person grows older. These are routinely checked by physicians during a physical examination.

Due to potential individual differences, measuring these signs in the same individual over some time can give useful individual reference ranges.

The primary vital signs are:

- Heart rate
- Temperature
- Blood pressure
- Respiration rate

Heart rate and temperature are chosen among these, to work on in this thesis.

### **2.1.2 Temperature**

Measuring body temperature could reveal fever and onsets of various diseases. Temperature is most often measured by oral, rectal, ear or armpit examination with a thermometer. However, measuring through the hands using a thermal sensor is also possible [8]. It could be of interest to monitor the room temperature as well, but Safestep will be moved and handled, which is not optimal for recording the temperature of the room.

### **2.1.3 Heart rate**

Heart rate may fluctuate and increase due to different reasons, such as exercise, emotions, illness, and injury [9]. It is the last three that could be of interest to detect signs of as early as possible.

### **2.1.4 Motion**

#### **Stair negotiation time**

Stair negotiation time (SNT) can be used to assess functional decline [10], [11]. The duration of how long an individual takes to ascend and descend 3 steps, can predict a functional decline. Descent time was shown to be greater with old age in both sexes, while ascent time was greater in men. Descent time also showed to be better at identifying decline than ascent time, because it was more strongly linked with previous falls [10].

Whether or not the change in SNT has clinical meaning has also been investigated. The article reporting this also used 3 steps and measured the time it took at baseline and again after a year [11]. This report suggests that an increase of 0.5 seconds for the three steps indicates a meaningful decline and a reduction of 0.2 seconds indicates meaningful improvement. It is stated that future studies are necessary.

## **Falling**

When monitoring the elderly, falling is crucial to detect as quickly as possible because injuries can be far more severe than in younger people. One complication of fall monitoring is that some activities of daily living could be mistaken for falling, e.g kneeling. The advantages of monitoring in the stairs are that a fall could be especially critical there and it is a place in the home where other activities than walking, seldom occur. That way, the probability of giving a false positive of a fall is likely less than in other locations.

## **2.2 Accepting being monitored**

There are a lot of good reasons to monitor an elderly individual and there is a lot of technology that could do so. But all that is pointless if the individual refuses to be monitored. When developing technology, the focus can be fixated on function and carried out with the best intentions, but lack an important understanding of the entire situation. Although the idea of monitoring the elderly to provide a safer environment sounds good, there have been studies looking into the acceptance of such technology. There seems to be a general acceptance of monitoring technology, especially ones that detect falls, tracks medical parameters and alerts emergency help [12], [13], but the same studies revealed what concerns there are regarding such technology. It is noted that both these articles used volunteers in their studies, which they also emphasise. This could be an indication that the results are mostly valid for the so-called innovators and the early adopters, two groups defined in the diffusion of innovation theory [14]. These groups represent people who welcome innovations and wish to explore without the need for the existence of proof that the innovations work as they should. The volunteers were reported to be frequent users of computers, and being volunteers, they may have an interest in such technology from before.

### **2.2.1 Concerns**

The concerns reported in [12], [13] were about who had access to the data that was recorded, violation of privacy when using video recordings, no one responding when help is needed, technology replacing human assistance, user-friendliness and the need for coursing adapted to seniors. In [12], the volunteers were asked to describe their level of concern at baseline and again after one year of being monitored. This showed that there was a greater concern regarding the exploitation of data after the year had passed, showing that there could be a naivety regarding monitoring technology before actually experiencing it. In [13], the goal was to "explore the perceptions and expectations", not reporting the experience of use.

### **2.2.2 Monitoring or surveillance?**

Getting old, and potentially frail, could be a sensitive matter to both the ones growing old and to their next of kin. Therefore it is important to approach this subject delicately. This report has already listed concerns regarding sensors and data being recorded in one's home. Knowing that these exist, the technology needs to be developed with these in mind. When

finally introducing the technology to the end-user, the individual's perception of whether this is monitoring or surveillance could have an impact on acceptance, as to monitor is defined as "to watch, keep track of, or check usually for a special purpose", while surveillance is "close watch kept over someone or something (as by a detective)" according to Webster's dictionary [15]. Something as simple as what word is used when presenting the product could affect the receptivity.

## 2.3 Privacy

Details surrounding someone's health can be highly sensitive. Therefore, handling such information must be done securely. That means not only to prevent people from gaining access to the information but also to secure that the people who are intended to have the information, actually get it.

The Norwegian Data Protection Authority has developed a list of guidelines regarding privacy [16]. It is based on the law that covers how private information should be handled [17] and is something that should be kept in mind when dealing with such information. The list is as follows:

1. Choose the least invasive solution
2. Limit the amount of data that is stored
3. Choose real-time solutions if possible
4. Information that is only used locally, should only be stored locally
5. Let the user have control over the solution
  - The more control is given to the user regarding what is recorded, the less invasive the solution is
6. Delete data after use
7. Limit the access to the information to as few as possible
8. Access to own data
  - The user should have easy access to own data, and know who else has access
9. Encrypt the data
10. Anonymize the data

## 2.4 Existing solutions

There are products monitoring the environment in people's homes [18], detects falls [19] and activity [20], which seem to come in non-wearable solutions. And some products monitor the health of an individual [21]–[23], but these seem to be mainly wearable sensors [24]. There have also been projects studying how to monitor someone's home for the sake of welfare, such as the master's thesis from NTNU called Monitoring Behaviour in a Domestic Environment [25]. There it was concluded that a platform for monitoring the elderly is possible to achieve at low cost and using simple sensors providing useful information to users. So the use of aids that monitor elderly individuals is well-established.

## 2.5 Discussion and Summary

This chapter describes what could be of interest to monitor while using Safestep and why. The discussion around acceptance from the elderly of being monitored and secure storage of the personal data needs to be discussed further. Individual differences need to be considered and there might be a need for personal adjustments to get acceptance for being monitored. Gradually moving towards a more technological everyday for the elderly can be necessary.

Information about personal health is sensitive information. The list from The Norwegian Data Protection Authority on how to handle such information is, as mentioned, guidelines. Striving to achieve as many of them as possible, should be done. How to handle personal data and how secure the storage is, is crucial to consider if the handling is secure enough.

When negotiating the stairs, the situation should remain fairly unchanged from one time to another. This allows for stable conditions, and the duration of time allows for a higher probability of good readings from the sensors. The matter of acceptance is also described, showing a generally positive attitude towards the monitoring of the suggested parameters (body temperature, heart rate, falling, stair negotiation time), with concerns, regarding e.g. privacy, also being discussed.

With regards to stair negotiation time, this could be applicable for the entire stair case, not just three steps. If there is a connection between changed duration when walking three steps, then it is likely that a change in total time also could be of significance. It could be used to identify a decline in health and if possible, implement preventive measures. The indication that there is a decline will in itself not be enough for a diagnosis, but it can be used as a reason to seek medical attention.

Some of the categories of existing solutions that are used to monitor someone is described. The main groups seem to be wearable and non-wearable monitoring devices. The sensors offered today can monitor many things and provide useful information to health personnel and provide a sense of safety for the resident.



# Welfare Technology

Welfare technology is technology made to improve people's quality of life. Welfare technology originated from a need to take care of those who are unable or less able to take care of themselves. The degree of dependence on assistance varies greatly from person to person. This chapter presents the different categories of welfare technology and what kind of rewards they could generate. This can be used to categorise Safestep and reveal what rewards are possible to achieve through it<sup>1</sup>.

## 3.1 The different categories

According to a report commissioned by the Norwegian Directorate of Health [26], called the ABC's of welfare technology, welfare technology can be grouped based on areas of use. These are:

- Technology that generates a sense of safety. This will also facilitate the possibility to live at home longer and counteract loneliness by enabling social interactions. Examples of such technology today are safety alarms, GPS, sensors that detect falling or other types of motion, and video communication.
- Technology that generates a sense of achievement. This is about mastering everyday living. Rehabilitation and maintenance of mobility are key aspects as well as being in control of one's health condition. Digital calendars, to-do lists, and ways of measuring different parameters regarding health are technology within this area.
- Examination- and treatment technology. Different sensors that perform readings of medical significance.
- Well-being technology. Technology that increases the individual's conscience about one's health and aids in chores. For example exercise apps and robot vacuum cleaners.

---

<sup>1</sup>This chapter is taken from one of the candidate's previous work on Safestep [5], with adjustments to fit the thesis better.

It is important to mention that this report also states that welfare technology is something that concerns all people and should be implemented in a way so that as many as possible can use it. The focus of this thesis is on the elderly, but this is not a contradiction of the target group of welfare technology, it is simply a constraint within that group.

## **3.2 The rewards**

Designing, developing, implementing, and introducing welfare technology must be done with the prospect of a reward. How a reward should be defined depends on what the technology aims to achieve. The Norwegian government has a goal of moving towards less institutionalised care and facilitating so that people can live in their own homes for as long as possible [6], the reward being a more independent and dignified way of life, but a financial incentive is also present [27].

The perception of a reward depends on the perspective. The Norwegian Directorate of Health operates with the following definition in a report mapping the findings from a national welfare technology program, "Rewards are beneficial use, advantages or positive effects that are expected achieved from a project or initiative. Rewards are desired and planned for, and preferably predefined, but can also occur as non-planned effects during and after projects" [28], and further divides rewards into three areas, increased quality, saved time, and avoided cost. This will be the same definition and areas viewed in this thesis when looking at it from the perspectives of the ones who are affected by the technology (i.e. next of kin, health care professionals, or the one receiving assistance).

## **3.3 Discussion and summary**

Welfare technology can help users with different tasks with varying difficulty. The help can give them an easier everyday and for some, the help gives them motivation for trying new things. The need for help is often from the elderly, but there are also people in need of welfare technology because of other reasons. In this report, the focus lies on specific helping the elderly with a technical solution helping them negotiating stairs while being monitored.



# Chapter 4

## Ageing in place

It is normal that elderly people increasingly develop injuries and diseases as they get older. Many need help to manage different everyday tasks like walking and cooking. This help can come from relatives, health professionals, or technological solutions.

This chapter describes the process of growing old in one's home, ageing in place. Society's financial view regarding this is presented, alongside the reported views among the elderly<sup>1</sup>.

### 4.1 The daily life

Ageing is defined as "a physiologic process characterised by the progressive decline in one's ability to withstand stress due to functional, cognitive and social limitations" [29]. Age is usually given in chronological form, but the physiological age can be crucial for the treatment decisions of elderly people. For the elderly a treatment might not just be about prolonging the lifespan, the extension of time spent as a healthy individual could be a better goal.

Functionality in the elderly can be divided into three levels [29]:

- Basic activities of daily living are tasks a person must be able to perform to maintain an autonomous life at his/her own home. These include bathing, dressing, eating, mobility and personal hygiene.
- Instrumental activities of daily living are tasks that must be performed by a person to maintain an independent household. These include housework, taking medication, shopping and the use of technology and public transportation.
- Advanced activities of daily living concerns societal, occupational and family recreation activities.

From these, it is shown that basic activities of daily living are the minimum requirements to live at one's home and mobility includes the ability to negotiate stairs.

---

<sup>1</sup>This chapter is taken from one of the candidate's previous work on Safestep [5], with adjustments to fit the thesis better.

**Ageing in place** is defined as "the ability to live in one's home and community safely, independently, and comfortably, regardless of age, income, or ability level" [30]. This is desirable for different reasons, some are from the resident's perspective, some are from the next of kin, and society can have something to gain from it as well.

## 4.2 Demographics

A report by Statistics Norway (SSB) from 2013, researched the situation on the use of health- and care services by the elderly [27]. This report was made because the amount of elderly in Norway is expected to double in the next 40 years. To be prepared for this, the needs of the elderly, their health, and how they use the health- and care services when their health declines, needed to be mapped. The report shows that women generally reach a higher age than men, but this difference is expected to decrease. One effect this will have, is that it will lessen the share of widows and therefore give married couples more time together. Being more than one person together is a factor when it comes to feeling safe and thrive in one's own home [31], so remaining a couple for longer, can lead to the desire to remain at home for longer. Even though two people living together makes it easier to get help once it is needed, the need for help is still there. Some tasks are easier when being two, but others, such as negotiating stairs, would be clumsy if two people with difficulties tried to assist one another.

## 4.3 Financial view

From a financial view, society is benefited from having people receive home-based care instead of moving into an institution. Estimates show that on average it cost 900 000 NOK per institutionalised person per year [27]. It is noted that this also includes institutionalised individuals under the age of 66, but 90% of these costs are from residents over the age of 67. Estimated costs per recipient of home health services were 227 000 NOK, once again noted, that this includes people under the age of 67. The significant difference in cost is a big argument for facilitating living at home for as long as possible.

## 4.4 The individual's view

Elderly people can have a strong emotional bond to their home and their community. A person who has lived for several years in one place will have gathered many memories and he/she knows where things are located. The neighbourhood and the community can provide social interactions with familiar people. In some situations, residents have built their own homes and can be reluctant to move out. These can all be seen as good reasons for why someone would want to remain in their own home. This could also be used to conclude that everyone wants to live in their own home as long as they can, there is after all "no place like home". This, however, can be a false conclusion. The housing preferences among elderly depend on location, the condition of the home, physical and mental health, access to informal help and social networks [31], and all of these can be adequate for a long time, but at some point, they may be insufficient, and the person could

want to move out. Therefore, facilitating the possibility of longer time at one's home, must not be misconstrued as the only thing that affects the resident's desire to live at home.

## **4.5 Does a longer life implies more healthier years?**

The decline in stamina and muscle strength starts at a young age [32], [33]. Muscle strength peaks at around age 30 and is approximately halved at age 75, and stamina is reduced by 1% every year from the mid-twenties. With increased age, sensory organs, and other organs also deteriorate. The decline in physical, social and mental abilities is unavoidable, but it can be postponed through lifestyle choices regarding for instance exercise, diet, alcohol consumption, and smoking [32]. Some diseases are correlated with ageing, such as stroke, arthritis, and Parkinsons. The process of ageing makes people more susceptible to these diseases, so slowing down the process could lead to better health and more healthier years of living.

### **4.5.1 Morbidity hypotheses**

People reach a higher age than before [27], [32], but there is uncertainty as to whether this leads to increased morbidity or not. Three hypothesises are supported by research [27].

- Prolonged morbidity, where the extra time consists of more sickness than health.
- Constricted morbidity, which is that not only is the increase in life expectancy composed of only healthy years, but the time spent as ill is also reduced.
- Postponed morbidity, where the extra time consists of healthy years but the time spent as ill remains the same.

The report from Statistics Norway [27] regarding the need for labor in health- and care towards 2060, considers postponed morbidity to be the most likely hypothesis and will be viewed as the most likely one in this thesis. The report from Statistics Norway also tells that the occurrence of serious diseases among the elderly has dropped, but the occurrence of less serious ones has not changed much. It is not concluded in the report, but it is justifiable to say that this increase in age can lead to a slower decline in health. Meaning that difficulties in life might occur more slowly and that the time from experiencing reduced functionality to the time where one is not able to take care of oneself, is longer. This opens up the possibility to introduce more technology and aids in the person's life so that he/she is still independent of human assistance.

## **4.6 Will the technology be accepted?**

For technology to be used so that people can live at home, it is important to know the user. Technology surrounds society in almost everything that happens, some have grown up with it, others have already been around for many years when it was developed. Elderly people have a harder time adapting to new technology, so when developing technology for the elderly, the interface and usage must be in accordance with this. Other factors that

come to play when accepting new technology is education. Low education is connected with lower confidence in one's ability to use new devices [34]. A design must, therefore, take into consideration the possible limitations elderly have, and come up with a product that is easy enough to use, not only focus on the practical advantages that are to be provided. Factors that are more difficult to account for is when the person who needs help sees his/her situation as a way of getting social interaction [35] and therefore might resist the introduction of technology that lessens the need for human assistance. Also, what one person might see as assistance, another might see as detrimental towards his/her independence. Forcing technology upon someone will not ensure usage, and developing and designing without feedback will also reduce the likelihood of usage. The user must have the choice of whether or not to use an aid and that the user group is involved in the development of it.

## **4.7 Discussion and Summary**

This chapter describes a future that not only involves a larger share of elderly, but elderly with improved health and abilities to "age in place". Awareness that it is completely individual preferences that decide whether a person wants to "age in place" or move into some sort of housing arrangement is emphasised. A financial view from society could be in accordance with what an elderly individual wants, but it could also be conflicting.

# Chapter 5

## The physical activity of ascending and descending stairs

Physical activity (PA) is defined as "any bodily movement produced by skeletal muscles that require energy expenditure" [36] by the World Health Organization (WHO) and they recommend a minimum of 150 minutes of moderate-intensity PA per week [37] for the elderly (aged 65 and up in this case).

PA is important at any age but especially important for the elderly. As mentioned in section 4.5, the elderly are prone to decline in muscle mass and stamina. Daily PA is important to reduce the effects and slow down the decline. Negotiating stairs is a physically demanding task, and even more so if one has reduced mobility. In this chapter, it will be shown that it is, and how it is, beneficial to facilitate the use of stairs for as long as possible. So even though an apparatus that helps someone negotiate stairs could reduce the beneficial effects, it is better than giving up stairs altogether<sup>1</sup>.

### 5.1 One- or two-step negotiating

A study investigating stair climbing and the effects it had on balance, strength and resting heart rate on healthy seniors [38], tested out a one-step and a two-step strategy when negotiating stairs. The program did not include descending, only ascending steps. The people involved in the testing underwent an 8 weeks program with 3 sessions per week, using an 8 level parking garage with 16 steps per level (a typical staircase between to floors in a private resident has 14 steps [39]). These levels were climbed on average 2 times per session during the first two weeks and on average 5 times per session the last two weeks. This means that the participants climbed 120 levels of stairs the last week. The results were that regular stair negotiation can provide positive results regarding resting heart rate and dynamic balance, which could lead to a reduced risk of falling and better overall

---

<sup>1</sup>This chapter is taken from one of the candidate's previous work on Safestep [5], with adjustments to fit the thesis better.

fitness, even more so in the group performing the two-step strategy. The study did not report significant effects on static balance or strength. It did however state that the people performing the program were healthy and active, and that the results would likely be better in seniors with reduced mobility.

### **5.1.1 Stairs for exercise**

Another study concluded that ascending and descending stairs can be considered a "viable exercise for most people and suitable for the promotion of physical activity" [40], when testing the effects of ascending and descending 11 flights of stairs. This would be an even more strenuous task for the elderly, and this could mean that the benefits might be greater.

## **5.2 Governmental advice**

The center for disease control and prevention (CDC) in the U.S Department of Health and Human Services, has made a report regarding PA and health with older adults [41]. This states that moderate amounts of PA can lead to significant health benefits, and even greater ones by increasing the duration and intensity. It also lists some of the benefits, like the ability to live independently, reducing the risk of falling, and reducing the risk of coronary heart disease. A similar summary can be found at the Centre for Health Protection in the Department of Health in Hong Kong [42], which lists benefits such as enhanced lung and heart function and blood circulation, healthier bones, and muscle strengthening.

## **5.3 Discussion and summary**

Negotiation of stairs can have health-promoting effects. This chapter has highlighted some of the benefits that stair negotiation can have when viewed as a form of exercise or PA. Although using the stairs at one's home might not be the most efficient means of daily activity, it is an available source for those living in a multistory home. Walking up and down is also something one can do without actively seeking to do PA, usually, the point of going up the stairs is something other than just going up the stairs. By enabling the use of this resource it is possible to increase the daily PA among the elderly, and with increased safety measures, elderly who desire to keep active can use the stairs to do so.

# Chapter 6

## Existing solutions

There already exist several products that help people negotiate stairs. This chapter will summarise some of these. By doing so it is possible to differentiate from what already is, and identify possible gaps in the existing solutions and use this to develop a new product that has competitive advantages<sup>1</sup>.

### 6.1 Assistep

Assistep is a product developed by Assitech AS. Their product is a handle that can be slid along a banister [43]. Assistep is manually operated. The user has to tip the handle slightly up and then push it forwards. It is designed so that it is possible to use it in different ways where the handle allows for different positioning of the hands. It is possible to install in private residences and care facilities. It is also a product offered by Hjelpemiddelsentralen [44], who supports people with functional disabilities with different equipment. The handle can be folded in so that it takes up less space when it is not being used. Assistep is only for indoor use, but is possible to install in stairs with a different design, for example, curved.

---

<sup>1</sup>This chapter is taken from one of the candidate's previous work on Safestep [5], with adjustments to fit the thesis better.



**Figure 6.1:** assiststep

## 6.2 Stairlifts

Stairlifts are provided by several suppliers. Due to their similarities in function, Stannah will be used as an example.

Stannah delivers several different stairlifts, suited for different needs [45]. There are models suited for indoor use and models for outdoor use, curved stairs, and straight stairs. Among their products, there are features such as seats that can be tilted backward to provide a safer feeling, seat belts, and different seat widths. In short, this is a product that can be tailored to many needs. To use Stannah, a person simply sits in a chair and is transported up the stairs by the push of a button. The user only needs to be able to sit down and stand up from the chair.

Stannah provides a service for those who are unable to negotiate stairs or feel that negotiating stairs is too exhausting or painful. Stannah can also be provided by Hjelpemiddelsentralen [46].





**Figure 6.2:** Stannah stairlift [45]

### **6.3 StairSteady**

StairSteady is manually operated. A single, horizontal pole is attached to a custom banister and the user simply needs to push it forward to move it and it is locked when weight is applied. This is done by having high friction pads in contact with the banister when weight is applied and low friction pads are in contact when pushed forward [47]. With the use of a single pole, the arms can not be held at the height most comfortable for the user. When not in use, the pole can be folded at the top and bottom of the stairs. The product is relatively small, compared to Assistep and Stannah, and therefore it might not be the same eyecatcher as such larger products might be.



**Figure 6.3:** StairSteady [48]

## 6.4 EZ-step

Unlike the aids mention so far, EZ-step is not mounted in the staircase. It is a walking cane with an elevated base [49]. When arriving at a stair, the user rotates the cane 180 degrees so that the base is directed towards the body. This will then be used as an intermediate step that is lower than the steps in the stair. It is then easier to place one foot on top of it and use this level to get up the step, as depicted in figure 6.4. The height of the cane is adjustable and it can be used both indoors and outdoors. EZ-step is less expensive than the solutions mentioned above and the same step can be used in several stairs, but the user has to lift the EZ-step for every new step.



**Figure 6.4:** EZ-step [49]

## **6.5 Discussion and Summary**

This chapter has presented solutions that all aid in daily living by assisting the use of stairs. Using the stairlift requires very little from the user, but then again it also eliminates the possible health benefits from walking in stairs. Assistep and Stairsteady allow the user to maintain most of the activity that is in negotiating stairs and therefore maintain or even better their physical form. Using the EZ-step also requires physical activity and you have to lift the product every step in addition to the walking.

A combination of monitoring aids, described in chapter 2, and a product helping people to negotiate stairs does not seem to exist today. This combination could combine the best sides of both products and in this way give added value. The market already has several aids for stair assistance and several monitoring systems, but some of these could be replaced by Safestep.



## Ideas and prototypes

The development of Safestep included early on visualisations and ideas regarding functions and appearance. This chapter covers the ideas and the prototypes that were dealt with in the process. A handle, banister, and brake system have been viewed. This has been done by coming up with ideas, then work on prototyping. The prototyping was limited to what was considered to be easy to prototype to get useful knowledge, in this case, that was the handle.

### 7.1 The handle

#### 7.1.1 Idea

The idea regarded how a handle could look for an aid used to assist in stair negotiation. To produce viable ideas for this, the situation needed to be specified:

*A Handle is in front of the elderly individual and is used for support when walking in the stairs. This handle should contain sensors that can monitor different things.*

With this, the following needed to be considered:

- The grip needs to be comfortable
- The grip around the handle needs to be strong
- The sensors might need to be placed so that contact is made with the person
- With use of sensors requiring contact, the hands must not be placed elsewhere than where the sensors are located

With these in mind, a walker was first thought of. A walker is an aid for those with reduced mobility, therefore it ought to be both comfortable and secure to hold on to. A potential

candidate for how the handles on Safestep could look was therefore like the ones depicted in figure 7.1. The handles are pointing towards the person using the walker.



**Figure 7.1:** Pictures of different handles on walkers

Other handles used as inspiration, is the ones on a stroller and a shopping cart. These often have a handle that lies across the direction of movement, like the ones in figure 7.2.



**Figure 7.2:** Pictures of handles on stroller and shopping cart

When thinking of a strong and good grip, the handles on bicycles were used for inspiration. These often come with an elevated centre where the palm lies. They can have more material on both sides of the hand, which can prevent the grip from slipping to the sides. The handles are often covered in a rubber-like material also preventing the hands from slipping. In this way, it is also very intuitive where the hands are supposed to be placed. Illustrations of these features are shown in figure 7.3.



(a) Slight elevation in the middle of the handle[55]



(b) Extra material on both sides of handle[56]

**Figure 7.3:** Handles from bicycles

## 7.1.2 Prototypes

With the ideas ready, the prototypes were to be made. Safestep's handles could easily be made as a prototype. The prototypes shown here consisted of a rolled-up sheet of paper, play doh (clay that is easily shaped), and a plastic bottle.

### Sheet of paper

This prototype consisted of two paper cylinders of rolled-up sheets of paper, simulating the possible handgrips. This was used to check the ideas of how the handle should be pointed and where sensors could be placed. With this, the "walker idea" was proven to be poor. The angle of the wrist could be quite uncomfortable when the candidates stretched the paper roll in front of them when walking up the stairs. Figure 7.4 are illustrating the handles held like a walker, the bad angle is seen in figure 7.4b.

Holding the paper roll like a shopping cart ascending and descending the stairs did not give the wrists any bad angles. This method was not uncomfortable at all and has a simpler design that is easier to produce. The grip using this method is shown in figure 7.5

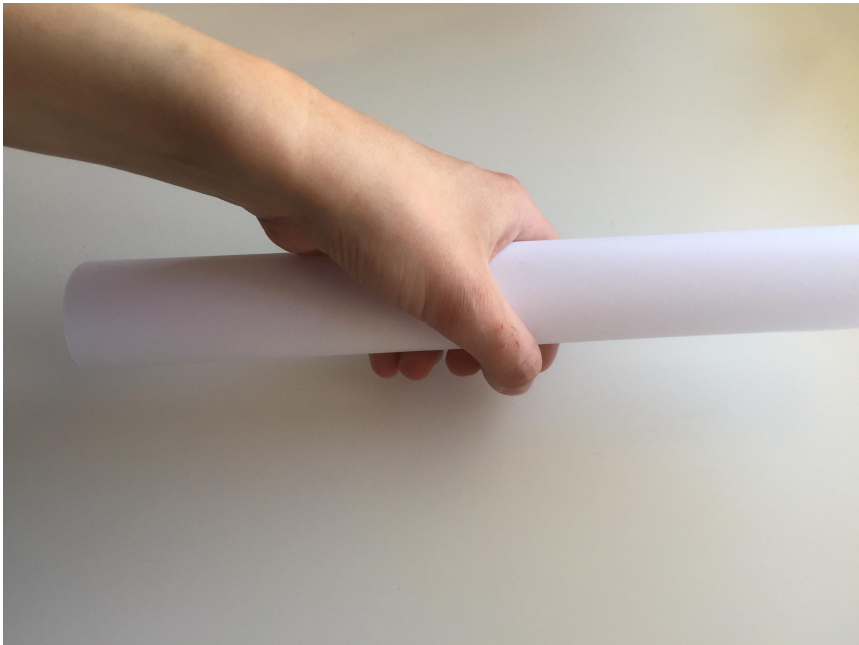

(a) Handle pointing towards the user, downwards

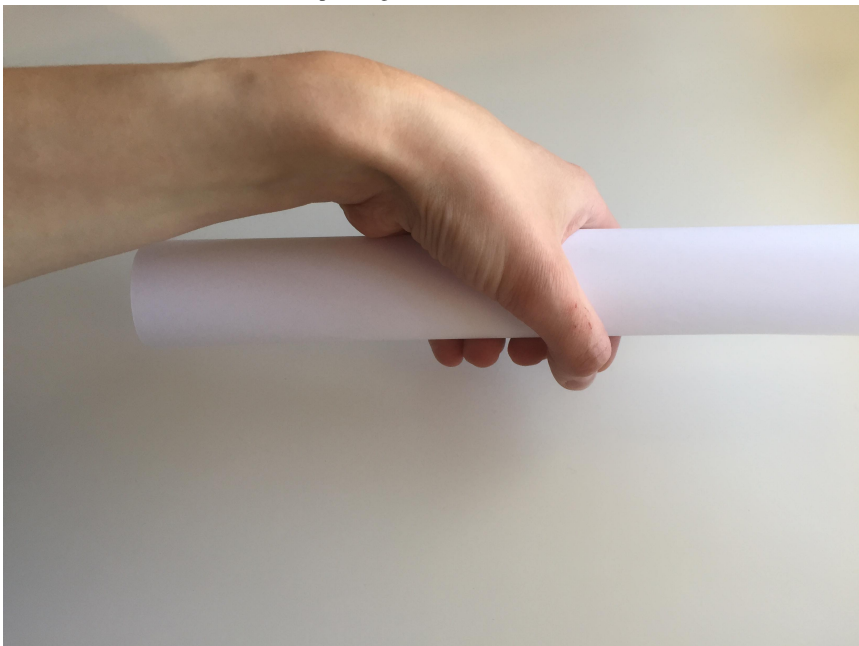

(b) Handle pointing towards the user, upwards

**Figure 7.4:** Paper roll simulating Safestep handles





**Figure 7.5:** Handle across the direction of movement

A challenge that emerged when trying to find the best handgrip was not only the direction of the handles but the height as well. What was discovered was that the banister installed in the staircase, could prove to be too low when walking down using Safestep. This is because when stretching the arms out to push Safestep forwards, the arms end up at a very low position. As figure 7.6 shows. Leaning towards something at that height could feel quite unsafe, especially for an elderly individual with reduced mobility. So in addition to the direction of the handle, the fact that a higher banister would most likely be needed was discovered.



**Figure 7.6:** How the upper body was angled

### **Play doh**

Play doh is a clay that can easily be shaped, and it was used to mold a handle. It was used to prototype the "bicycle handle". By putting play doh on to a cardboard cylinder, it was possible to shape out a handle with an elevated centre, and more material added on the sides. This can be seen in figure 7.7a. By using the play doh, it was easy to shape and get a feel for how it fitted in the palm.

With a handle that looks like that it gives the possibility of a powergrip, which is a comfortable and strong grip [57]. The prototype was made to fit only one hand. By making it symmetric, it could be tried with both hands and it can be held from both sides, which would be the case of a handle mounted in a staircase.



(a) Example design for best suited handle

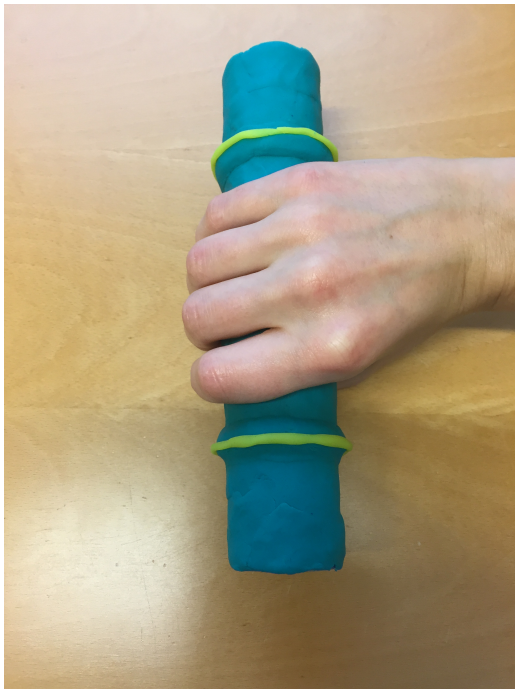

(b) Grip on the handle

**Figure 7.7:** Handle made in play doh

## Plastic bottle

At the same time as prototypes were made, different sensors were chosen to work with. These are sensors reflecting what was covered in chapter 2, and is written about in detail in chapter 11. The sensors relevant for this part of the thesis is listed, for readability purposes:

- Temperature sensor
- Thermal camera
- Physical pressure sensor
- Heart rate sensor

To decide where to place the temperature sensor on Safestep, a plastic bottle was used. This was chosen because it was possible to attach the temperature sensor and its wires to it. How it looked is shown in figure 7.8.

To get a good reading from the sensors, the temperature sensors should be placed at a spot where the hand will have good contact with the handle. When holding on to the plastic bottle this seemed to be anywhere on the fingers or 2-3 cm closer to the palm. This was done to find placement while holding the hand still, it did not take in to account the movements that can happen when walking. The measured temperature is likely closer to the body temperature in the palm, and the fingers less so, because of inequalities in blood supply out to fingers. Therefore the top of the palm seemed to be a good place for the temperature sensor after testing with the plastic bottle.

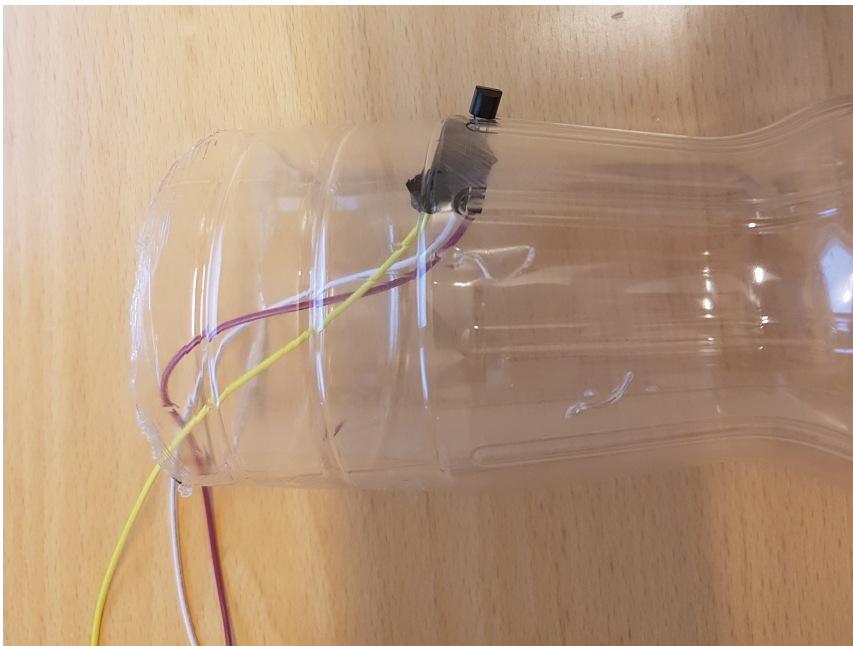

**Figure 7.8:** Plastic bottle with sensors

How it looked while trying the prototype, is shown in figure 7.9

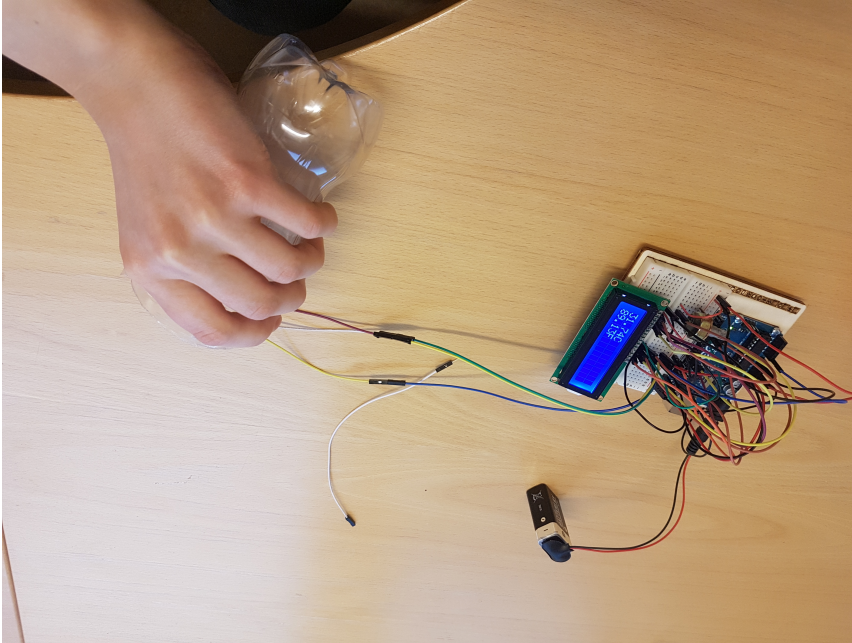

**Figure 7.9:** Plastic bottle with sensors

### **Sheet of paper #2**

To try to see where the other sensor could be placed, a simpler approach was taken. Two sheets of paper were rolled up and taped together. The rest of the sensors were then drawn onto the paper, to see how they would fit. What seemed to work was the following:

- The two infrared thermal cameras will point towards the user's face when walking up and down the stairs, therefore they can be placed on the top of the handle, between the hands, angled towards the person's face. One for ascending, the other for when descending.
- The pressure sensors need to be placed so that they register whether the user pushes Safestep forwards or is pulling himself forward. One sensor can be in each hand. These can be located just below the temperature sensor.
- The heart rate sensor uses three electrodes. The choice was to place the electrodes where a person is most likely to place his fingers on Safestep. The best contact will then be when the person is pulling his body towards Safestep.

## **7.2 Brake system**

Before Safestep is ready to use by an elderly individual, brakes will have to be implemented. The actual development of such, is not done in this thesis, but ideas regarding it are presented here.

A braking system for Safestep will brake for safety reasons and the user's comfort. Electrical powered brakes could be used for comfort and mechanical brakes for the security. Mechanical brakes will work even in the event of a power loss, thereby increasing safety. Another important way to increase the security to the Safestep is to use a combination of different braking systems. In this way the probability for the brakes to fail will decrease significantly. Having three different braking systems working independently from each other will only lead to total system failure if all of them collapse at the same time. If each one of the braking system has a small probability of not working, the failure of the total system will have a minimal probability of happening. The system could then be considered as safe. Alternatives for different braking systems have to be considered further.

A challenge with a brake system for Safestep is identifying all the different situations when brakes could be necessary. Falling is probably the most important reason. But falling could happen in different ways. The person could keep their grip as he falls forward so that the force applied to the handle will increase gradually, but he can also lose his grip completely and a sudden force can be applied with the upper body landing on Safestep. It is important to know as much as possible about the possible ways someone can fall and then implement brakes that can handle all these situations. A possible solution for a mechanical brake, is inspired by the system used on roller coasters. If a rack and pinion is used, there could be a metal tip pointing out towards the rack. If the power goes off, the metal tip will prevent the coaster or in this case, Safestep, slide backwards. The tip will lock itself in holes along the rack and can't move either ways. If a button is included that can retract the metal pin, then Safestep can still be used if the power is gone. Then it would be necessary to actively retract the metal pin to move Safestep.

## **7.3 How to move Safestep along the banister**

### **7.3.1 Drum moving up and down cable**

A possible way of creating forward motion is to connect Safestep to a drum that moves up and down a cable, spun around the drum. As illustrated in figure 7.10 Safestep will be able to move along the cable up and down next to the railing. Safestep will in this case be held in place by the friction between the cable and the drum connected to Safestep. With this solution there can be a challenge to let the drum rotate as it moves up and down without letting Safestep do the same. Safestep must stay in the same position only moving straight along the railing. In this way the sensors will work as planned having connection to the same part of the hands at any time.

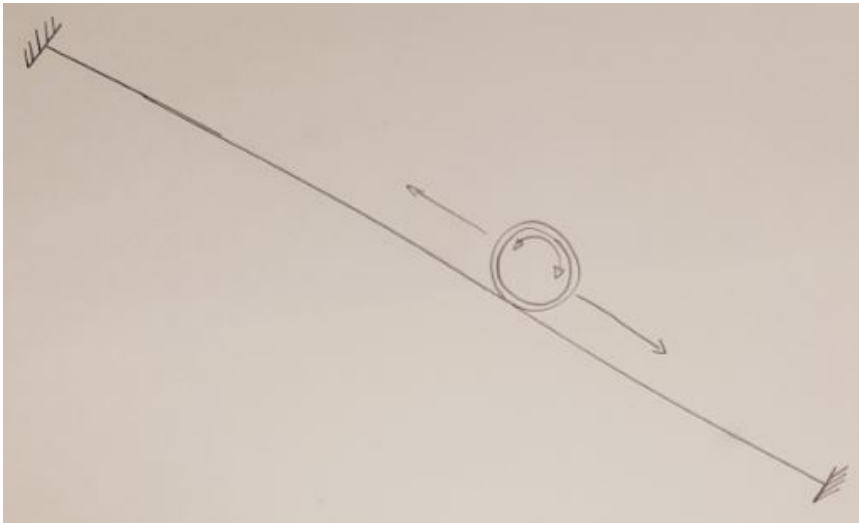

(a) The drum along the railing

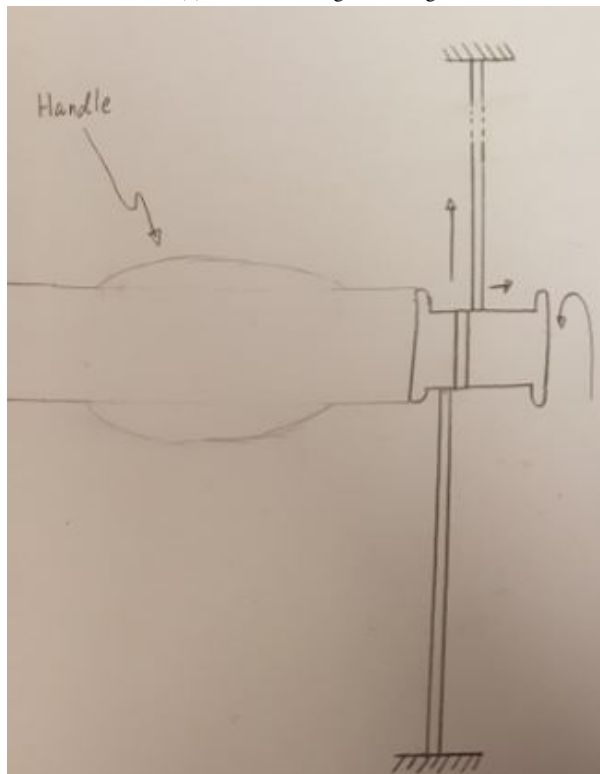

(b) The handle connected to the drum

**Figure 7.10:** Illustration of the forward motion system with drum and cable

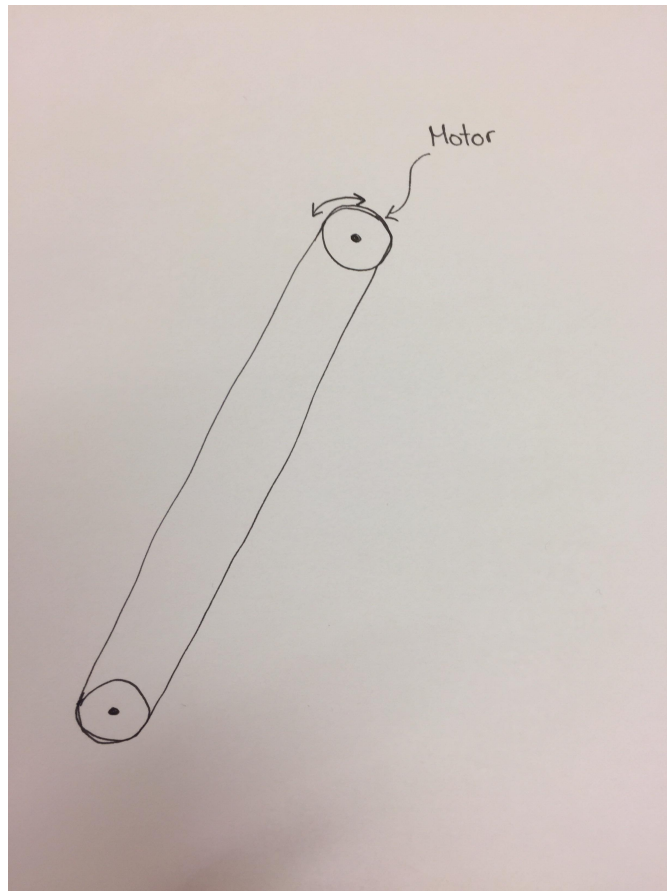

**Figure 7.11:** Rolling bicycle chain on the banister

### 7.3.2 Bicycle chain system

To create forward motion for Safestep, Safestep can create the movements, or the attachment-point to the banister can move because the banister moves. Safestep is in this case connected to a specific point on the chain, but this point moves up and down as the gears go around. This solution to get the Safestep to move forward includes bigger parts to move and it will be necessary to build a completely customised railing. As seen in figure 7.11 a transportation solution can be made with two gear and a chain.

### 7.3.3 Rack and pinion

Creating forward motion can also be done with the use of a rack and pinion as illustrated in figure 7.12. The pinion is the gear that can be connected to the shaft of a DC motor, that is attached to the end of the handle, that is closest to the wall at the end of the handle. The rack can be attached to a banister. With the rack fixed, a rack and pinion work so that



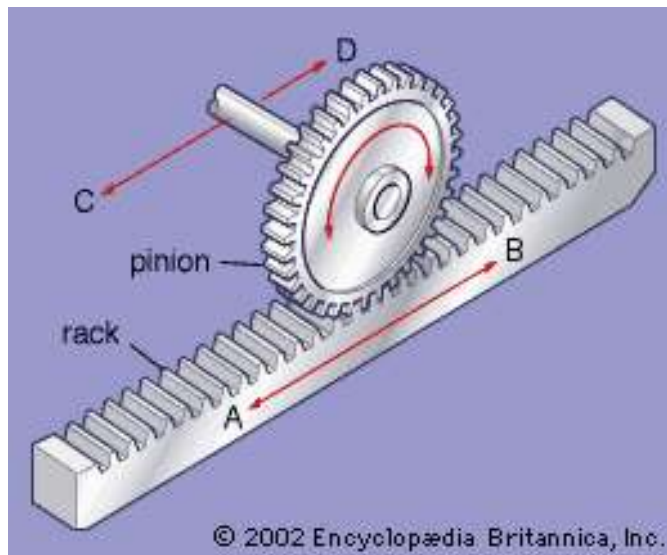

**Figure 7.12:** Rack and pinion [58]

it is the pinion and whatever attached to it, that will move [58]. What is shown in figure 7.12 is that the pinion can move in direction CD and the rack can move in direction AB, depending on which of the parts is fixed.

## 7.4 Iterations

This chapter has dealt with prototyping. During a process with prototyping, it is important to keep going back to make changes if deficiencies are detected or changes is wanted. In this way, the product will be improved continuously while working on the development. Working on the prototype with model wax, the handle was tested by holding it before small changes were made and the handle was tested again. Working this way is effective to figure out what is best, but it will be more comprehensive if the prototype is testing a more complicated function. In this project, iterations have been in focus when working on small provisions and are not taken into account as much when working on these bigger and more comprehensive functions.

## 7.5 Discussion and summary

In this chapter different solutions for a handle, banister, and brake system have been viewed. This has been done through investigating ideas and prototyping. All though simple prototypes, they seem to have revealed some useful points, like how the handle could be directed. The comparison with a stroller, shopping cart, and walker is sensible.

The walker is an aid, and many elderly people use it. To assume that this solution could be good, was therefore rational. But the way the wrist got angled when using "the walker solution" revealed that this could prove to be too uncomfortable. There might still be other options, even better ones. But compared to the existing solutions in chapter 6, a handle directed across the direction of movement, like the shopping cart or stroller, seem to be the most used. It also showed no signs of discomfort in the wrist when the candidates held the rolled-up paper in this direction. It is noted that a more complete prototype could reveal things not yet discovered. Also, the bicycle handles shown in this chapter, seem to add some important aspects for an aid aimed at elderly people. The slight elevation in the middle that allows for a better grip and the extra material on the sides to prevent slipping seems like a valid appearance for Safestep. Also, this makes it quite clear to the users where they should place their hands, which is very important if sensors that require contact with the individual are to be used.

Further, how to fit the different sensors was looked at. The sensors used are for the intended ways of monitoring an individual's health. They were all fitted on to a paper roll that resembles a handle because they are all candidates to use on Safestep. It is possible that some prove to be of too little use, and therefore not included. This would make more room for the remaining sensors, and fitting them on to the handle would have to be repeated. Should the sensors prove to work well, specialised printed circuit boards can be manufactured, and the shape and size could be adapted to fit Safestep better.

A factor that leaves room for uncertainty, is how these sensors will work when walking. A person's grip is likely to change during stair negotiation. This could affect where the placement of sensors should be.

Regarding the banister, height is an issue. It was clear that a person who fully extends his arms would end up leaning quite a lot forwards when descending the stairs. This could lead to an imbalance and an increased risk of falling.

The rack and pinion solution on a banister seems promising. It needs to be investigated further, with a prototype and on different kinds of stairs, e.g stairs with curvature. With the use of a motor to assist in moving Safestep, something it can move along would be necessary. But none of the existing solutions in chapter 6 use anything similar. This could mean that none of the people behind those products thought of having a motor, but also that the idea could have been discarded by them. The need for this is not clear, but it is still looked at further because it is too soon to conclude of potential benefits.

Brake system is briefly looked at, but the idea that electrical breaks can be used to achieve a comfortable experience when using Safestep, and mechanical for safety reasons appear to be good. With the target group being elderly people, accidents can have severe consequences. With mechanical breaks for safety reasons, loss of power does not necessarily mean loss of safety. But with possible severe consequences in the case of an accident, more than two different ways of breaking might be needed.

In summary, this chapter has looked at a handle, banister, placement of sensors and breaks for Safestep. Promising candidates for each were revealed and can be worked on further.

To illustrate the intended use, figure 7.13 shows Safestep in a staircase. This figure will evolve throughout the report as more is developed.



**Figure 7.13:** Safestep in the stairs



# Chapter 8

## Design and calculations

In this chapter, the candidates have taken a more detailed look at design, based on the findings in chapter 7. More precisely, a handle has been modelled and calculations and simulations have been performed on it. Suggestions on how the handle could look, how it can be connected to a banister, and how a banister could be designed are also included here.

### 8.1 Design of handle

The design of the handle on Safestep is simple with some customisation for a comfortable grip. The handle must be designed so that it can be used for both ascending and descending the stairs. The design of the handles is chosen to have a slight elevation in the middle of the hand to fit the natural pit in the palm of a hand. This gives a larger contact area between the hand and the handle which gives a comfortable and strong grip [57]. In Figure 8.1 it is seen which parts of a palm that normally will be in contact when holding a handle formed as a cylinder. The red colour symbolises the area with good contact, the yellow shows the area with varying contact, and the green area shows the area not necessarily in contact at all. This shows where to place the sensors that need better contact with the hand than the others. The candidates discovered this through a simple test by holding a cylinder and registering what parts of the palm that was in contact with the cylinder. This revealed that an elevated centre, like what was shown in the bicycle handle in chapter 7, could result in a bigger part of the palm is in contact with the handle, and consequently with potential sensors on the handle.



**Figure 8.1:** The contact surface of the hand

The candidates proceeded with the added material on both sides of the hands as well, as described in chapter 7. As this could prevent the users of Safestep to slide their hands off the handle because of the edges on each side of their hands. The appearance is illustrated in figure 8.2. The yellow is added so that the edges on the handle can be seen more clearly.

Hand grips are a big part of everyday life and are something we can not get away from. There has been a lot of research in this area and it is something almost everyone has a connection to. Safestep's handle design has been developed with inspiration from earlier study of handgrips and the author's own experiences. When finding a handle, the size of the handle, the shape, and the surface are important to consider to make a good handle as seen in [57]. The size will be optimal if the fingers just cross the thumb when holding around the grip. In this case, an approximate value of an average-sized hand will have to be used for the handle to be best optimised for all the potential users. According to [57] the handle should have a diameter between 3cm and 4cm to get the strongest grip for an average sized male hand. To have the handle the best size for both female and male the prototype of Safestep handle will have an outer diameter of 3,5cm. This will also give enough space to fit all the needed electronics inside of Safestep.

The design of a handle is commonly known as something without sharp edges and other protruding parts. Most people would think about circular-shaped handles often seen as handlebars on a bicycle, wheelbarrow and other products with handles.

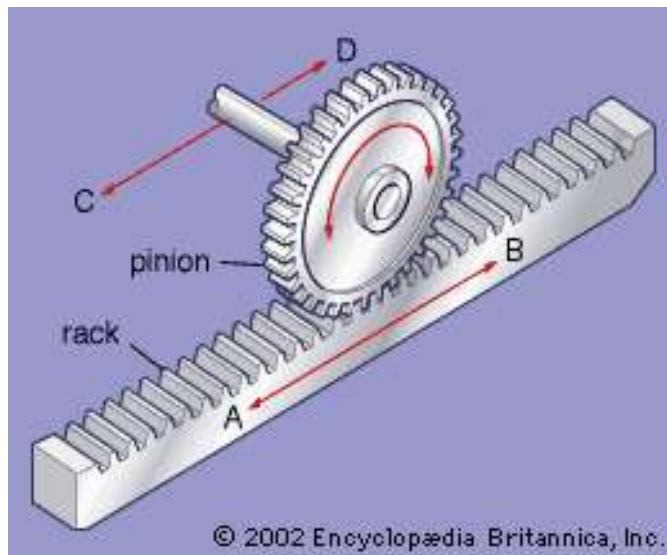

**Figure 8.2:** Prototype of handle

## **8.2 Connection between banister and handle**

In this section, what connects the handle with the banister will be referred to as the connection.

With the use of a DC motor to assist in moving Safestep, it is necessary to have a connection between the handle bar and the banister that the motor can move along. This needs to be a smooth motion considering the target group of Safestep. To achieve this, the rack and pinion covered in chapter 7 is assumed to be a good candidate, and is chosen for further development in this part of the thesis.



**Figure 8.3:** Rack and pinion [58]

In the connection it would be practical to have the possibility to tilt the handle towards the wall when not in use. This will give a free path to use the stairs without using Safestep. If the mechanism for pushing away Safestep is made horizontal it would be a risk of folding the handle during normal use. This would have had to be prevented from happening during stair negotiating. An expedient solution would, therefore, be to have a folding mechanism in the vertical direction. It is least likely that the user pushes the handle in this direction during normal use, therefore it will not be necessary to prevent the movement during use.

In the beginning of the design phase, a safety solution for the system with sawtooth and cogwheel was to lock it in the position if the motor stopped. A security mechanism to stop the handle from moving downwards without the user's desire. This will make Safestep hard to use if a power loss occurs. If a power loss occurs when the user is in the middle of the stairs they can have problems getting up/down without Safestep. For Safestep to make sure the user gets out of the stairs, this function will not be part of the solution.

Designing the connection started with drawings of different solutions trying to find something that could work. Beneath are four examples of sketches of the banister and the connection. The ideas are based on avoiding too much moment in the clamping when force is applied to the handle. The sketches all include a rack and pinion as described earlier.



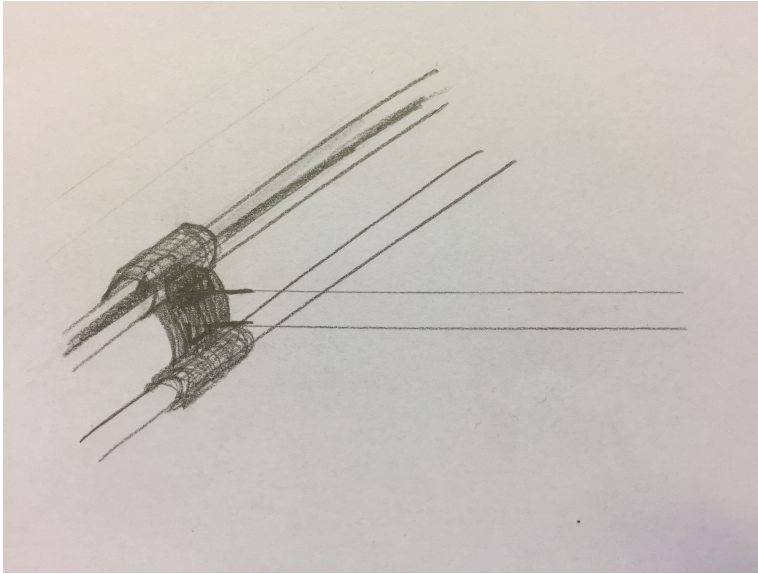

(a) Example 1, banister, connection and the handle

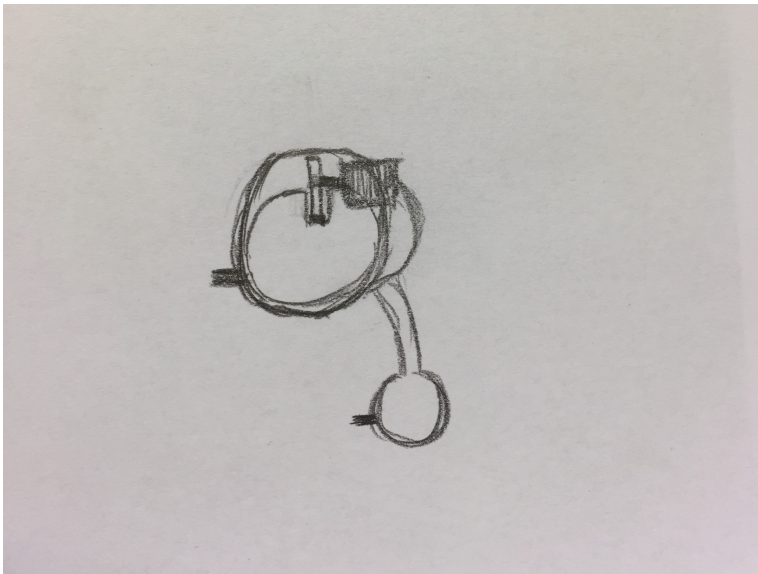

(b) Example 1, profile of the banister and connection

**Figure 8.4:** Example one of a sketch of the connection

This first sketch in figure 8.4 is quite similar with the one in figure 8.5. The banisters both consists of two cylindrical rods that passes through the connection. The rack is placed in the upper rod as seen in figure 8.4b and the pinion is connected to the shaft of the motor and the motor is placed inside the connection.

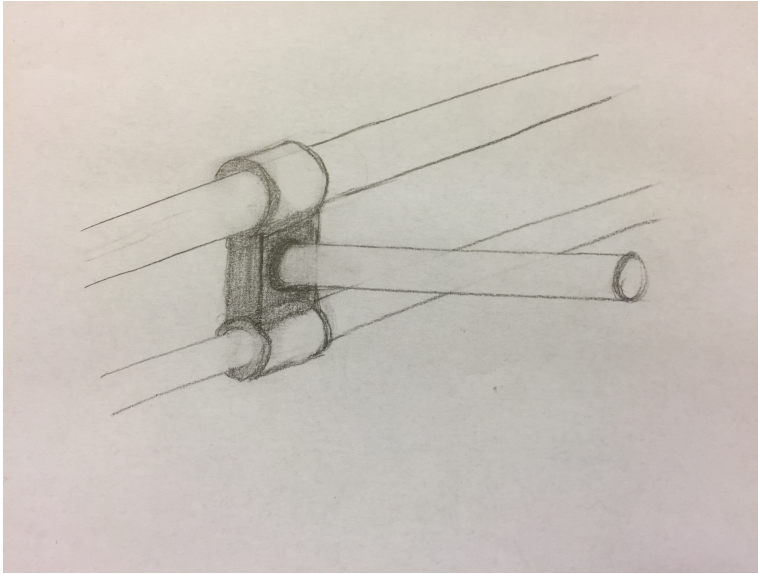

(a) Example 2, profile of the banister and connection

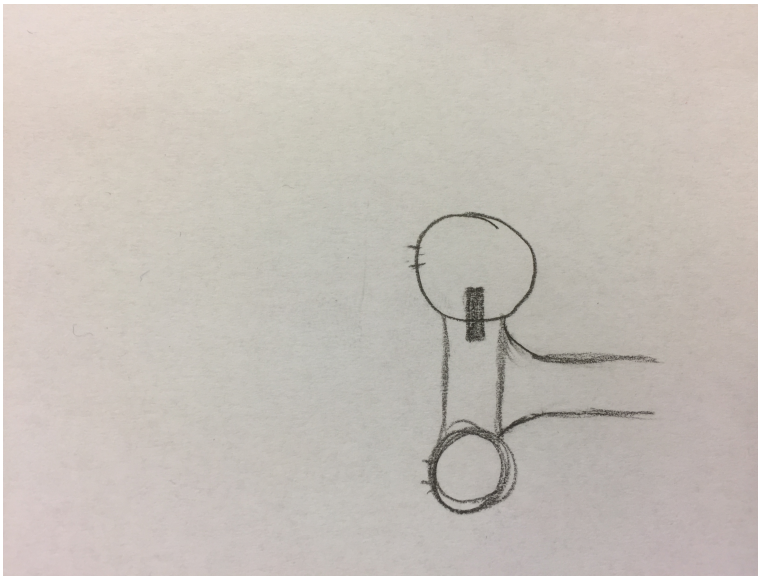

(b) Example 2, profile of the banister and connection

**Figure 8.5:** Example two of a sketch of the connection

Another sketch is shown in figure 8.6, it has a banister with a rectangular cross section. Figure 8.7 has a similar cross section on its banister, but with a protruding piece near the bottom. Both systems are pretty similar with the main difference of where the rack is placed, at the top of the banister on Figure 8.6 and on the protruding piece on Figure 8.7.

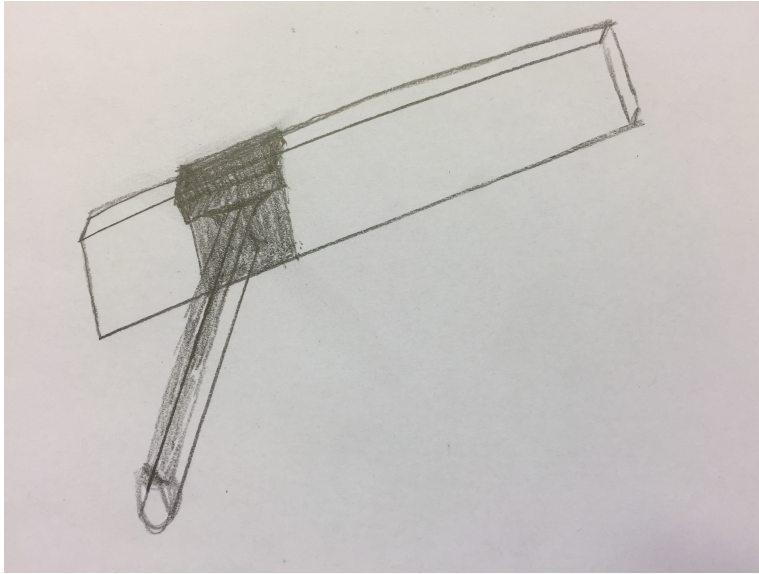

(a) Example 3, profile of the banister and connection

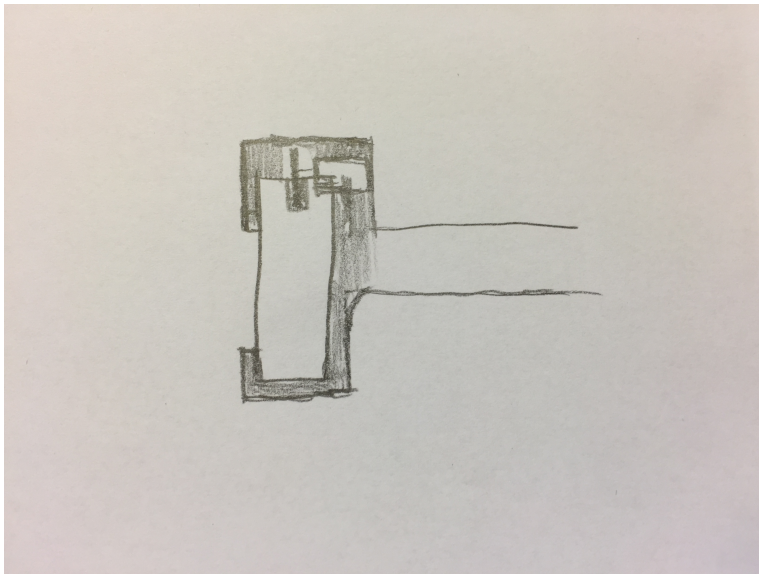

(b) Example 3, profile of the banister and connection

**Figure 8.6:** Example three of a sketch of the connection

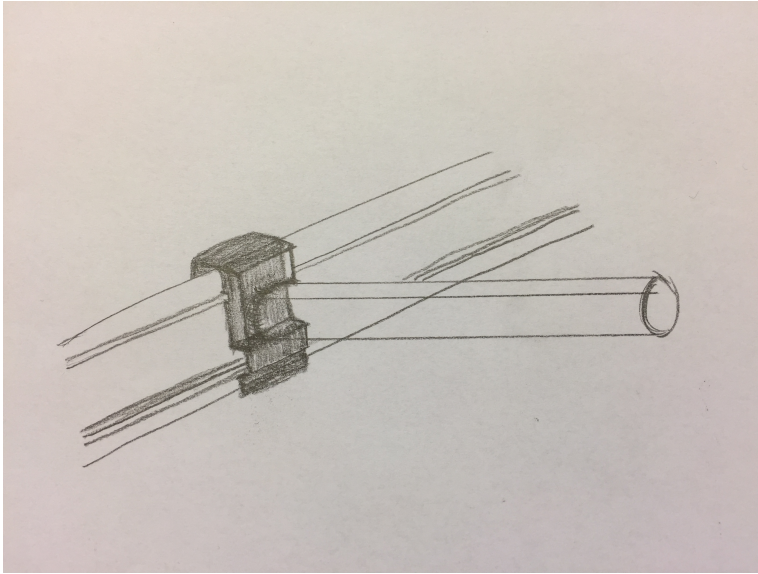

(a) Example 4, profile of the banister and connection

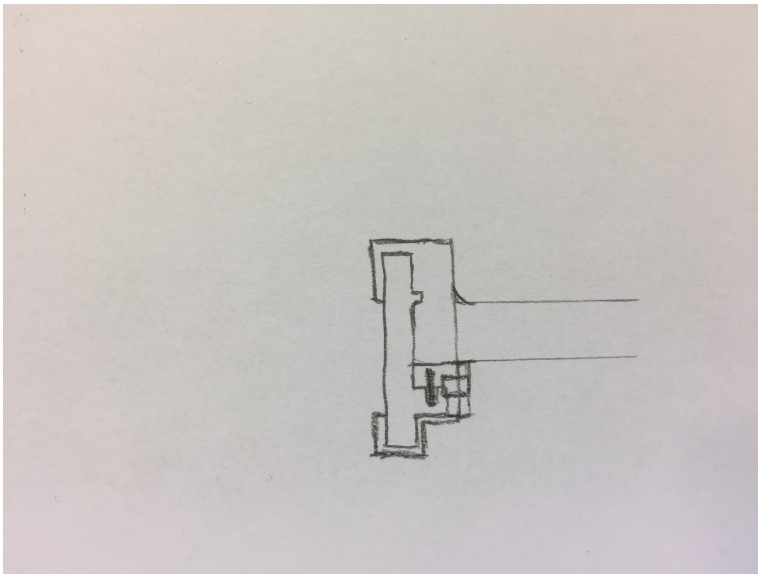

(b) Example 4, profile of the banister and connection

**Figure 8.7:** Example four of a sketch of the connection

## 8.3 Banister

Most staircases have banisters installed, and the ideal solution could be to have Safestep installed onto the already mounted banister. This could reduce the cost of Safestep and it would possibly be easier to install Safestep in the user's home. No such existing solution has been found among the other aids similar to Safestep seen in chapter 6. It is the conclusion of the authors that it is too complicated to design a connection that will fit all the possible banisters available today.

Another reason for a custom banister is the height. As shown in chapter 7, Safestep is wanted to be higher above the floor than the height of the banister already installed in the staircase. When choosing height, adjusting it to the descent is deemed more critical than the ascent, because falling forward when descending could lead to more severe consequences.

## 8.4 Safety

There will always be possible hazards and there is no exception with Safestep. Various accidents can occur. The use of a cogwheel and sawtooth rack will open up to possible crush injuries. The user or visitors can accidentally put their fingers to close the cogwheel when Safestep moves along. This can cause destroyed fingers, but it can also lead to a fall which again can cause worse injuries. To prevent this the propulsion system should be hidden beneath a protective layer of rubber or another soft material.

All edges on the handle and the connection are rounded to avoid lacerations. Lacerations are therefore seen as unlikely to happen, but one can never predict every possible event. There is a bigger change for possible crush injuries made from the folding mechanism envisaged. This mechanism will open for the possibility of tilting the handle upwards which can cause a new situation for getting pinched. It is important to design this solution with safety in mind.

## 8.5 Proposed model

Earlier work in this chapter have given the candidates the ability to make a preliminary computer aided model of the handle and the connection to Safestep. This model has been used to do simulations seen later in this chapter. It also gave a good impression of what the candidates believe would be close to a final design, seen in figure 8.8.

When making the model, it was revealed that the connection might need to be quite big to fit a DC motor inside. The candidates used a 12V DC motor that they had been working with previously, to get a rough estimate of how big a motor could be.

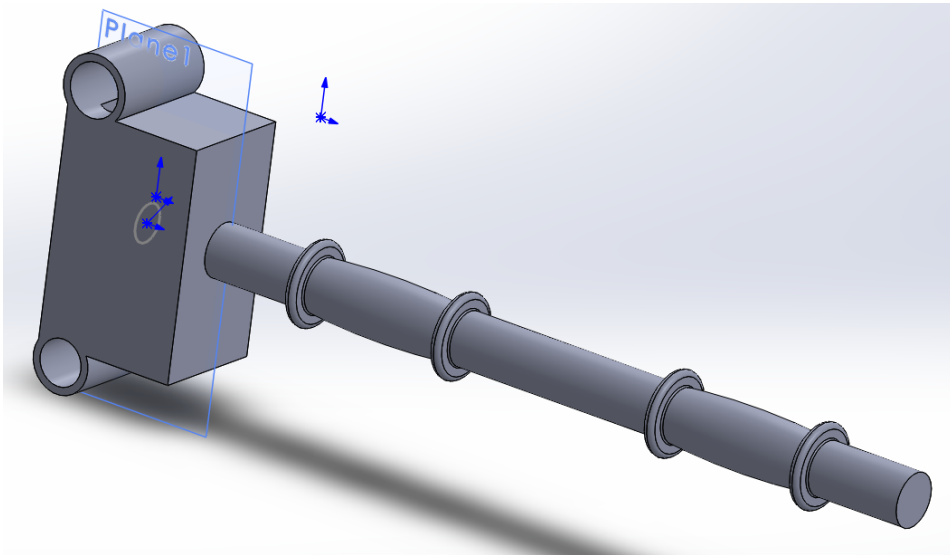

**Figure 8.8:** Model of Safestep

## 8.6 Calculation of strength by hand

Looking at how much Safestep can withstand of use and affixed load, it is necessary to look at the handle, the connection to the banister, and the banister itself. When deciding the design of the connection between the handle and the banister it was taken into account a potential large moment. The potential large moment was decreased by having a banister with two pipes to distribute the load on two parts with a certain width between them. Nevertheless the connection is where the most amount of moment will be and is therefore important to look at.

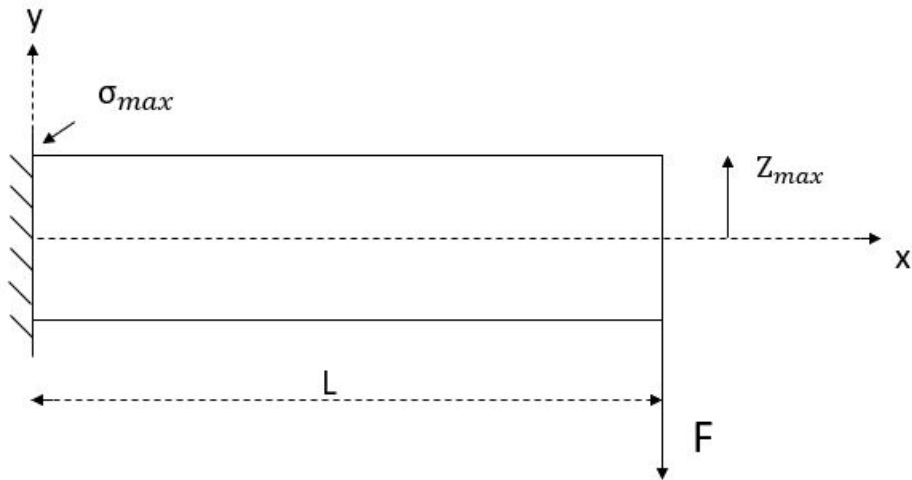

**Figure 8.9:** Cantilevered beam

When calculating the strength of Safestep it is important to look at the torque in the clamping. A simplification of this calculation will be looked at like a cantilever beam with an applied force as seen in Figure 8.9.

$F$  = applied force

$\sigma_{max}$  = maximum stress

$L$  = length of the beam

$Z_{max}$  = maximum vertical distance from neutral axis

In a worst-case scenario the applied force will be concentrated at the endpoint of the beam, applying the biggest torque. This will be the case if the user falls with all its weight on the point at the very end of the handle. This scenario gives a moment-diagram as seen in Figure 8.10 with clearly the biggest moment in the connection as mentioned earlier. Beneath, an approximation of the stress applied on the handle will be calculated. The applied force used in this approximation will be 981N which is the highest possible force made from a person with weight 100kg. The applied force is of this size to make sure Safestep can handle the weight of a person of 100kg falling with all its weight on the outer edge. The handle is hollow for the necessary electronic, used to monitor, to fit inside. This can be seen in Figure 8.11. The outer diameter of the handle has its value from a suitable size for handgrips and the inner diameter have to make sure all the electronics can fit inside as well as make sure the strength of the handle can handle its use.

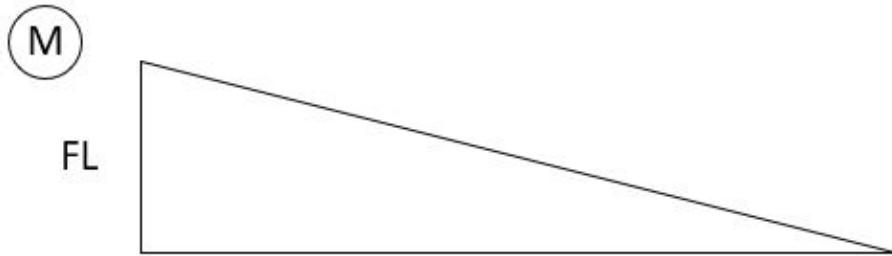

**Figure 8.10:** Torque

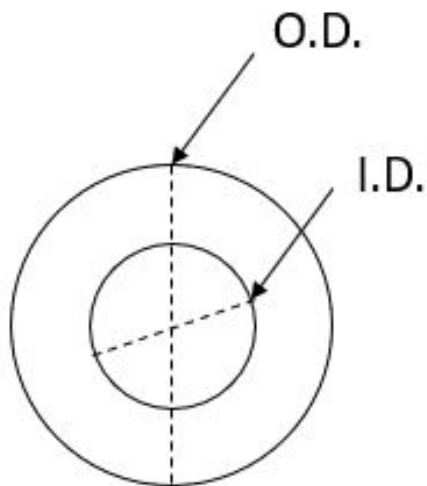

**Figure 8.11:** Outer and inner diameter

Calculation of Safestep's yield stress is explained in equation 8.1 to equation 8.5.

$D$  = outer diameter

$d$  = inner diameter

$A$  = cross section area

$L$  = length of the handle

$I$  = moment of inertia

$Z_{max}$  = maximum vertical distance from neutral axis

$M$  = bending moment

$\sigma_{max}$  = maximum stress



Safestep's stress value is compared to the material yield strength, here steel(AISI 1020). The material needs to be exposed to less stress than the yield strength of the material to stay in the elastic deformation area. All deformation made in this area will go back when the forces decreases.

$$F = 100Kg * 9.81 \frac{m}{s^2}$$

$$L = 500mm$$

$$OD : 35mm = D$$

$$ID : 25mm = d$$

$$I = \frac{\pi(D^4 - d^4)}{64} = 54487.0mm^4 \quad (8.1)$$

$$A = \frac{\pi(D^2 - d^2)}{4} = 471.24mm^2 \quad (8.2)$$

$$Z_{max} = \frac{D}{2} = 17.5mm \quad (8.3)$$

$$\sigma = \frac{M}{I} * Z \quad (8.4)$$

$$\sigma_{max} = \frac{FL}{I} * Z_{max} = \frac{981N * 500mm}{54487.0mm^4} * 17.5mm = 157.5MPa \quad (8.5)$$

*Yield strength* :  $\sigma_y$  steel, AISI 1020 = 350MPa

$$\sigma_{max} = 157.5MPa$$

$$\sigma_{max} < \sigma_y$$

$$157.5MPa < 350MPa$$

The calculations above indicate that the choice of material is strong enough to withstand the estimated maximum load. This means that Safestep will be able to withstand the wanted load. Another important calculation is about the size of the deflection resulting from an estimated load. If this is bigger than what is comfortable for the user of Safestep, the load will anyhow be too big. The deflection is illustrated in Figure 8.12, exaggerated to show the deflection clearer.

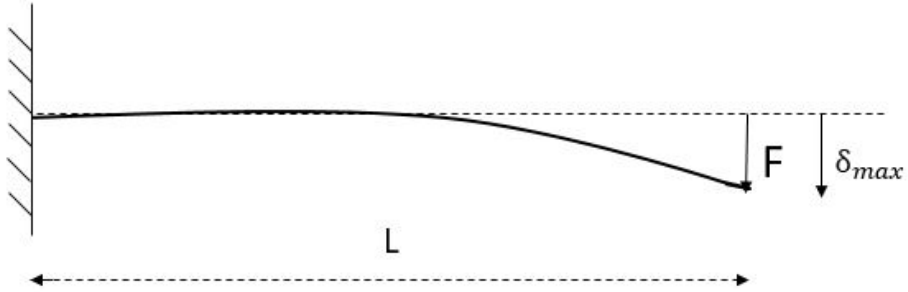

**Figure 8.12: Deflection**

Once again,  $F$  is applied force,  $L$  is length, and  $\delta_{max}$  is maximum deflection. Calculation of deflection in the handle is done in equation 8.6. The calculation is made with the same applied force as earlier, the worst-case scenario. The deflection is calculated to be 3,66mm with steel as the material and this is considered small enough to be accepted. It is considered to be unnoticeable.

Elastic modulus is a measurement of a material's resistance to elastic deformation [59], for this particular steel it is:  $E_{steel, AISI 1020} = 205GPa$

$$\delta_{max} = \frac{F * L^3}{3 * E * I} = \frac{981N * (500mm)^3}{3 * 205 * 10^3 MPa * 54487.0mm^4} = 3.66mm \quad (8.6)$$

## 8.7 Vulnerable points in the attachment

The most exposed parts in Safestep are the attachment between the handle and the banister. The points where the different geometric parts meet each other will be the most vulnerable points. These points can be seen in Figure 8.13 and are worth to notice. The four points closest to the attachment to the banister(closest to the two circles) will distribute the torque formed by the stress. The two points to the right in Figure 8.13 have to hold almost the same amount of torque and will, therefore, be the two weakest points. These points are not specifically calculated, but are worth an extra thought. They should, therefore, be secured extra when composition of the connection part, for example with welding.

## 8.8 Calculation of strength with Abaqus

The handle and its attachment to the banister are simulated in the program Abaqus to get a more real analysis on how the material in Safestep will be affected with applied forces. It is important to notice that these calculations are simplifications like the calculations

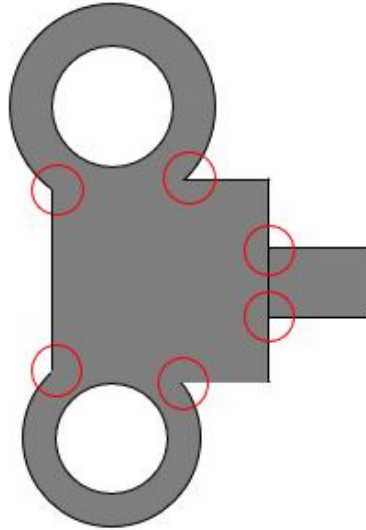

**Figure 8.13:** Weak points in the attachment mechanism

made by hand. The simplification here is made in the way the computer calculates, but the calculations are made from a provisional model. The calculations by hand in section 8.6 was made by simplifying the geometry to an already familiar geometry.

Figure 8.14 shows the scale of the yield stress used to decide the colours in the three simulations of Safestep beneath. All the values in the Figure are values in MPa and the colours divide the stress into different levels. The red indicates the most amount of stress on Safestep, but it does not indicate that the stress level is too large. The values have to be seen in context with the material yield stress of 350MPa. Red stress values are approximately half of the material yield stress, far within the safety margin, which will be discussed later. Figure 8.15 shows the expected deflection from the side as well as the yield stress when the handle is exposed to a load of 981N, like previously. Figure 8.16 and Figure 8.17 shows the yield stress from other perspectives. Because of the simplifications written about earlier, the calculations include insecurities. It is therefore important to use a safety margin as mentioned above.

It is normal to use a factor of approximately 1.3 and multiply this with the calculated yield stress and then compare this value with the material yield strength.

For hand:

$$157.5MPa * 1.3 = 204.75MPa$$

$$204.75MPa < 350MPa$$

$$\text{With Abaqus: } 181.4MPa * 1.3 = 235.82MPa$$

$$235.82MPa < 350MPa$$

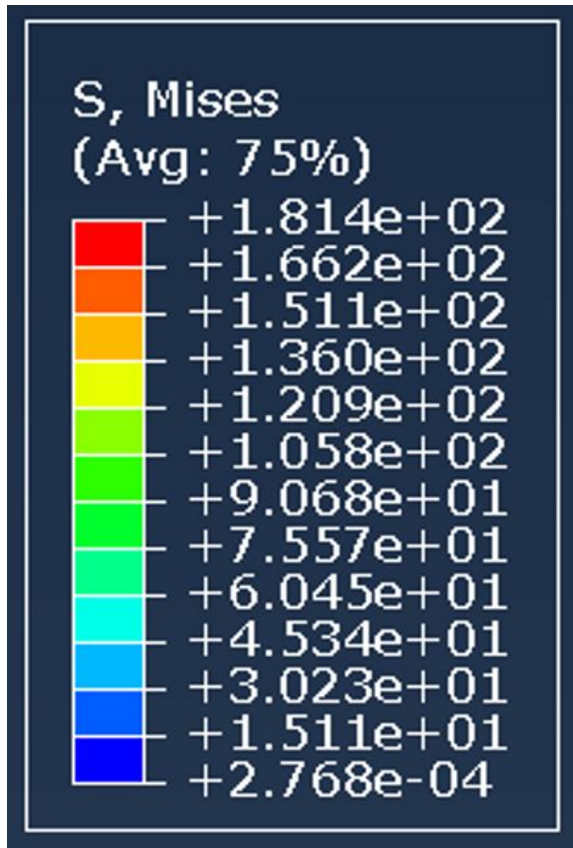

Figure 8.14: Scale of yield stress

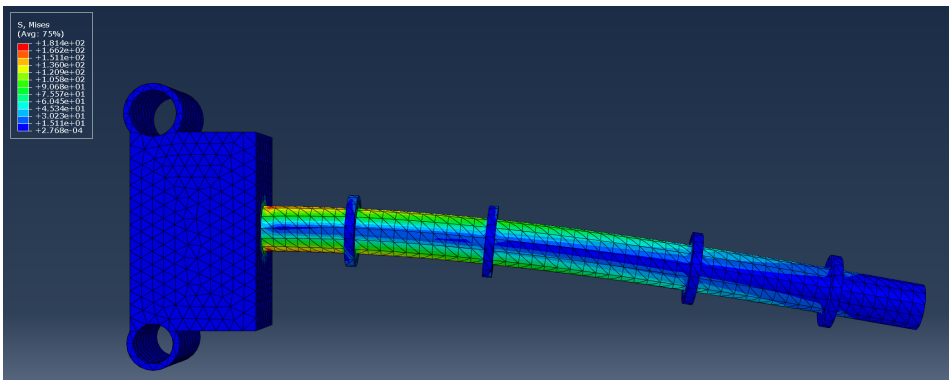
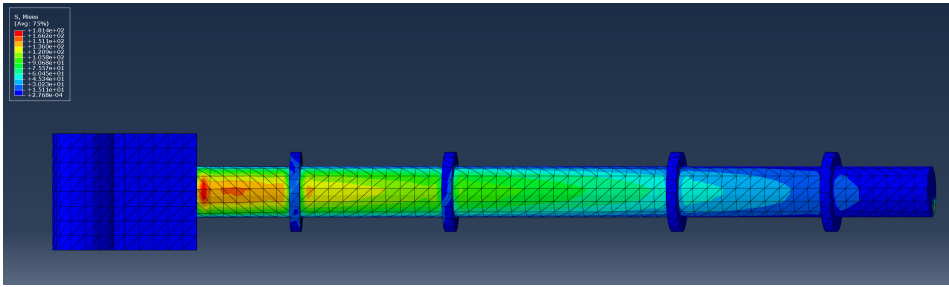
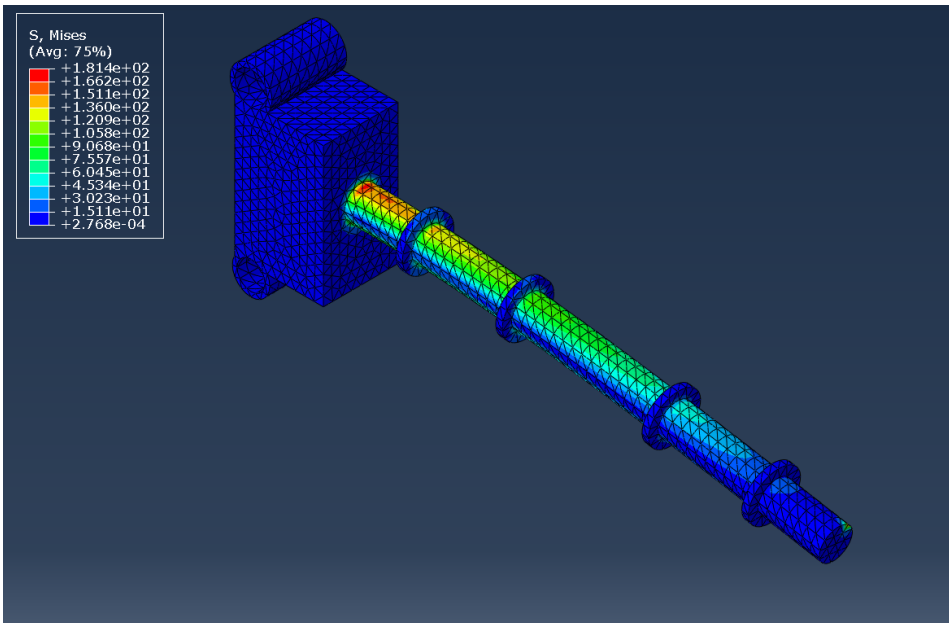

Figure 8.15: Strength analysis Side view



**Figure 8.16:** Strength analysis Bottom view



**Figure 8.17:** Strength analysis ISO view

These values are far within the safety margin and Safestep will probably withstand the estimated load. The difference between the calculated values by hand and with the use of Abaqus has a difference of approximately 15%. A difference is expected with different simplifications in the two methods, a deviation of 15% is a promising result.

### 8.8.1 Choice of material

To choose the material for Safestep the salvage above must be taken into account. The material must withstand the possible load on Safestep, the system has to be able to hold Safestep's weight and the dimensions and design need to be comfortable to hold. Safestep's handle needs to have enough space inside to fit all the needed sensors and other equip-

ment. With this taken into consideration, a material that can work for Safestep is to be Steel (AISI 1020). This is the material used in the calculations above which shows that it is strong enough for this use.

## **8.9 Discussion and summary**

The proposed design of Safestep, has been presented in this chapter, through a more in-depth analysis than what was done in chapter 7. The sketches are instruments that allows other people to see what the candidates picture when coming up with a potential design. This is still characterised by the ideas of the candidates, which could prove to be faulty. But it also resembles that of Stairsteady, an established product. It is also quite basic, with few innovations, but rather a combination of known design features from other products.

Through calculations and simulation, the proposed design has been investigated to see if it can withstand a load of 100Kg at the outer edge of the handle. The candidates were also able to make a model that could be used to simulate the force applied during use, more specifically the most amount of force. Without being able to make the handle, banister and connection in between, calculations and simulation was considered to be a good substitute, and can be used as a reference if further development is decided. Being such an early stage of development, changes to the design are likely to happen at a later stage.

In summary, this chapter has looked at different solutions regarding the design of handle, banister, connection between banister and handle, how a rack with pinion gear could allow for the use of a motor assisting the moving of Safestep as a person uses it. This has been done through sketches, calculations, and simulations. Resulting in a suggested model that can be used as a reference if development continuous, as well as a suggestion of material based on a worst-case scenario of stress.

# Chapter 9

## Sensors

In chapter 2, what could be monitored was discussed. In this chapter, different categories of sensors that can be used will be presented. Later, choices are presented regarding which sensors have been used in the work on this thesis. The ones not used remain as potential candidates for later development should it be needed.

What to register	Possible sensors/technology
Temperature	Thermocouple, resistance temperature detector, semiconductors/IC, thermal camera
Heart rate	ECG (electrocardiogram), PPG (photoplethysmography)
Stair negotiation time	Reed switch, proximity sensors

**Table 9.1:** Possible sensors/technology to use with Safestep

In table 9.1, falling and activity level are not included. These can be measured by any sensor used in Safestep. Falling can be detected if one or several of the other sensors detect abnormal readings, such as loss of contact. The activity level could easily be measured by seeing how often the other sensors are activated.

### 9.1 Temperature

Necessary qualities for a temperature sensor are that body temperature can be detected and that readings do not fluctuate too much from one time to another, because body temperature does not vary much.

#### **Resistance temperature detector (RTD)**

RTD measures temperature based on a change in resistance in a metal resistor. It is constructed of a metallic wire surrounding a glass or ceramic core [60]. The resistance will increase with increased temperature. Its operating range is typically  $-220^{\circ}\text{C}$  to  $750^{\circ}\text{C}$

### **Semiconductor/IC**

Semiconductors come in the form of ICs. They are mainly differentiated on how their output is changed.

- Voltage output temperature sensor changes its voltage output linearly with change in temperature, an example is the LM35 from Texas Instruments [61].
- Current output temperature acts as a constant current regulator, a change in  $1 \mu\text{A}$  per degree Kelvin.
- Resistance output sensor. A thermistor is one such type of semiconductor. It changes its output based on the fact that its resistance changes exponentially with temperature [60]. It can have very good accuracy if it is calibrated well. Compared to the RTD, it has a narrow temperature range.

### **Thermal camera**

Temperature can also be measured by filming infrared radiation. This will create a heat map of the person being filmed. This has previously been used to detect elevated body temperatures in passengers at airports during outbreaks of diseases such as SARS, bird flu, and Ebola [62]. One disadvantage with this is the intrusion of filming someone, a concern described in chapter 2.

### **Thermocouple**

Measures temperature by combining two dissimilar metal wires at two points. If there is a difference in temperature on these two points, a voltage is generated and can be measured and converted to temperature [60]. Suitable when detection of large temperature range is required.

## **9.2 Heart rate**

Requirements are the ability to measure heart rate during the duration of time it takes to walk the staircase and it needs to do so through the hand or fingers, without being attached to the individual being measured. The two dominant types of measuring heart rate are electrocardiogram (ECG) and photoplethysmography (PPS)

### **PPS**

PPS is a technique where infrared light is transmitted towards human tissue and then reflected back to a photodiode [63]. The amount of light reflected will vary with blood volume in the small vessels near the surface of the skin. This can then be used to detect heart rate.

### **ECG**

ECG is a graph showing voltage over time from the electrical activity of the heart, and a lead is a graphical presentation of the electrical activity of the heart measured between two electrodes attached somewhere on the body [64]. There will be a difference in electrical potential between these two electrodes, which is then displayed graphically. Figure 9.1



shows an ECG graph and the peak is called a QRS complex, a very distinct part of the graph. By registering the time between every QRS complex, it is possible to read a person's heart rate [65].

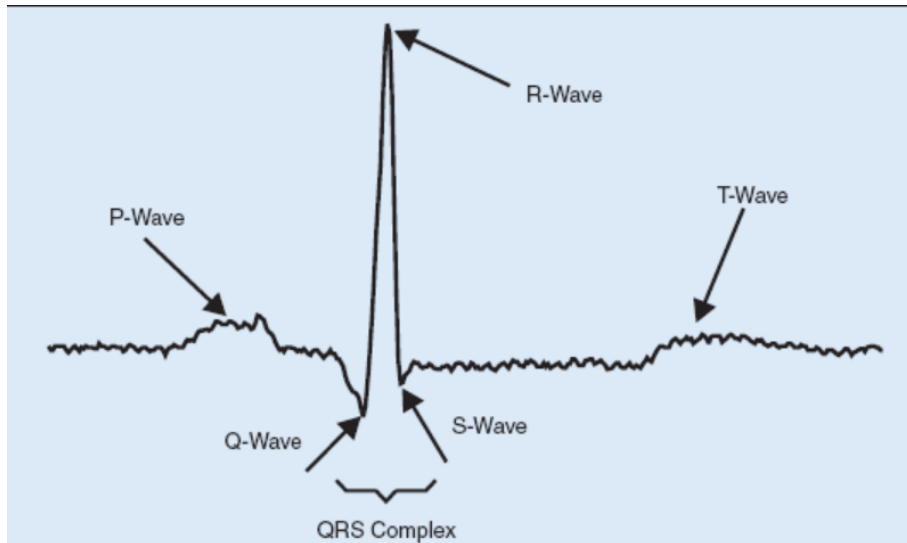

Figure 9.1: An ECG graph [65]

### 9.3 Stair negotiation time

Safestep needs to be able to measure the time it takes to walk from top of stairs to bottom and the other way. There are likely many ways of doing this, but in the interest of efficiency, reed switch and proximity sensors are the only ones discussed here.

#### Reed switch

A reed switch is an electrical switch that is magnetically activated. It has two, normally separated, wires. When these come in proximity of a magnetic field, they will come in contact with each other, creating a connection allowing current to flow, thereby including it in the circuit. Away from a magnetic field, the connection is open, and current can not flow [66].

#### Proximity sensors

Proximity sensors can detect nearby objects. Different proximity sensors are depending on which material you want to detect and how the surroundings of the sensor are. Proximity can be measured by inductive sensors (detects conductive material), capacitive sensors (can detect any material and humans), photoelectric sensors (detects anything, can have difficulties with highly reflective surfaces) or ultrasonic sensors (can detect anything) [67]. Proximity sensors could be attached to the top and bottom of the stairs and the time it takes between both are activated can be a way of measuring the time.



# Chapter 10

## Technology and protocols worked with

With the use of various hardware, certain technical terms will appear, which components are used is covered in chapter 11. Some of these use specific protocols and methods. The ones used in this thesis are inter-integrated circuit protocol (I<sup>2</sup>C), pulse width modulation (PWM), and universal asynchronous receiver transmitter (UART). Also, Safestep could use Bluetooth to convey information about someone, so the Bluetooth protocol is explained. How a motor driver and a DC motor works. The understanding of all of these is not crucial to understand how Safestep would function, but an explanation of them is still provided in this chapter. This can provide an even clearer understanding of how Safestep operates.

### 10.1 Pulse Width Modulation

Pulse width modulation (PWM) turns a digital signal into an analog signal and can be used to control the speed of a DC motor [68].

A digital signal is either high or low. By controlling how long the signal stays high or low, the output can be whatever value between high and low. If the voltage source has a maximum of 5V, and this source switches between high (5V) and low (0V) at a fixed frequency, the output can be any value between 5V and 0V. The high value will be held at a pulse width within a fixed period. This will result in a waveform as depicted in figure 10.1. The waveform has a duty cycle that is defined as the ratio between the time the signal is set to high (the pulse width,  $t$ ) and the period of the waveform, given as a percentage. The frequency,  $f$ , is related to the period,  $T$ , of the wave in the following way

$$T = 1/f \tag{10.1}$$

and the duty cycle is expressed as

$$duty\ cycle = \frac{t}{T} 100\% \quad (10.2)$$

If the signal in figure 10.1 had a high value of 5V, then the 50% duty cycle would output 2.5V.

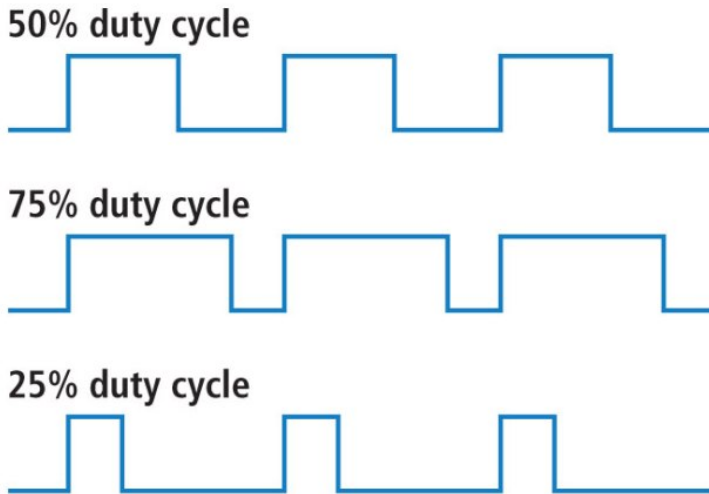

**Figure 10.1:** Examples of different duty cycles with PWM [69]

## 10.2 Motor driver

A motor driver is needed to gain control of the speed and direction of a DC motor. It is also needed when the motor requires higher power than the microcontroller, power which could also, damage the microcontroller if passed through it.

A low current digital signal from the microcontroller will control the motor driver which in turn controls a larger amount of current supplied to the motor, through the use of switches. Within a motor driver that allows for bidirectional current flow, there is a configuration called an H-bridge [68]. This is four switches (e.g MOSFETs) that are arranged in an H pattern. These four switches are divided into two pairs. By closing only one pair, the current is allowed to flow in one direction, making the rotor turn in one direction. By using a PWM signal to open and close one pair of switches, the rotational speed can be controlled as well. The same can be done with the other pair, the speed is controlled in the same way, but now the motor moves in the opposite direction.

The H-bridge configuration is shown in figure 10.2. Here, switches S1 and S4 are closed and S2 and S3 are open.

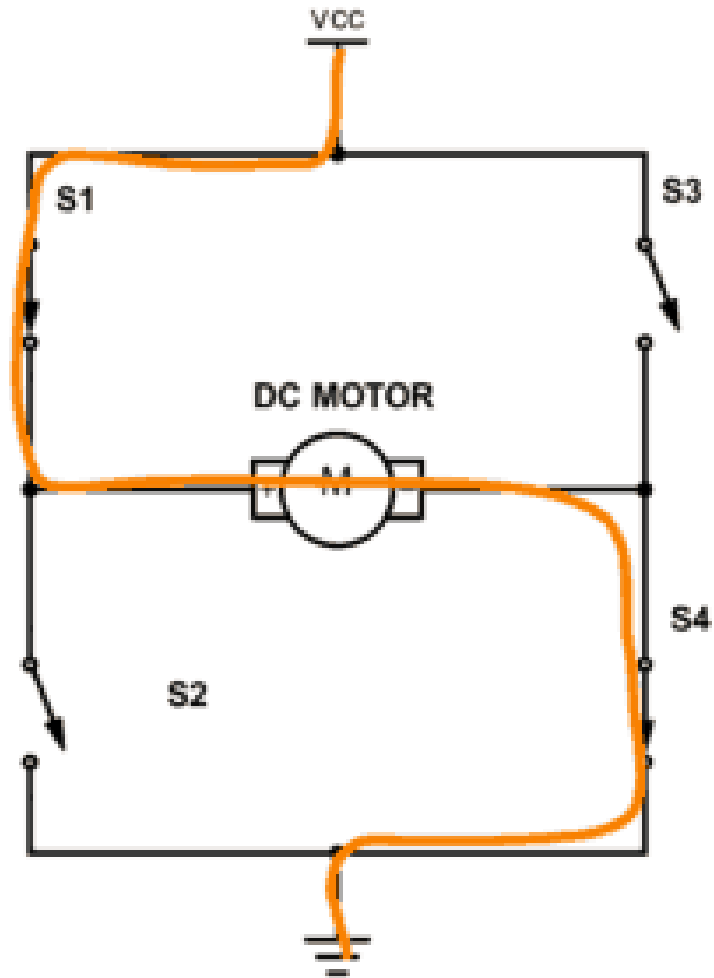

**Figure 10.2:** H-bridge configuration [70]

Figure 10.3 shows a motor driver with both a microcontroller, a higher voltage power supply, and a brushed DC motor (BDC) connected to it. The microcontroller is powered by a low voltage source, which can deliver a PWM signal to the motor driver (DRV8871). The motor driver can then deliver a PWM signal to the BDC from the larger power supply.

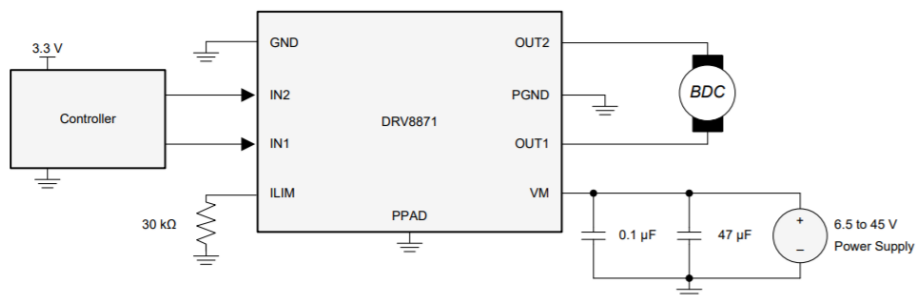

**Figure 10.3:** Combination of microcontroller, motor driver and DC motor [71]

### 10.3 DC motor

By having a DC(direct current) motor connected between the handle of Safestep and the banister, it could be easier to push Safestep forwards when negotiating the stairs. Other stair aids with similar functionality as Safestep, shown in chapter 6, require the user to push the aid along the banister, and Assistep requires a tilt before pushing it. With the use of a DC motor, the moving of Safestep could require only a small effort from the user, which could be useful for people with reduced upper body strength.

Safestep would not move at great speeds, the requirement is that it can move as fast as an individual can stretch out his arms. Safestep would be placed in people's homes, therefore the motor must not produce a lot of noise. The distance Safestep would move will vary between staircases, but it is a matter of meters. It also needs to move forwards and backward. All of these requirements could be fulfilled by a DC motor. Most DC motors are reversible. Connecting a DC motor to a motor driver and microcontroller allows for speed control through PWM and it can change direction. DC motors can respond quickly due to a high ratio of torque to rotor inertia [72].

The windings of a DC motor is supplied with a current which produces magnetic flux. This magnetic flux interacts with the permanent magnet of the DC motor creating revolutions of the armature. To control the current flowing through the windings, one can use PWM. By controlling the duty cycle the average current through the motor changes, which changes the speed. Using PWM has the advantage of low power loss in the switching transistor because of it being fully on (high) or fully off (low).

The DC motor used by the candidates was one that was close at hand. The focus was on making it respond to the forces that a person would apply to Safestep. Since no particular motor was required at this stage of development, this has not been focused on in this thesis, but how to calculate torque is still described.

The situation described is when the person using Safesetep has fully extended their arm and is about to move forwards whilst pulling themselves towards Safestep. When this happens, Safestep needs to stay still, so there needs to be static equilibrium.

The easiest way of measuring what torque the motor would have to endure is by using a measuring instrument. The candidates could have done so using a Newton meter. There would have to be safety margins included, since how much force is required will vary from person to person. How to calculate what torque the motor than would need to withstand is provided.

What torque the motor would have to withstand depends on the force applied to the gear attached to the shaft. Assuming that Safesetp uses the rack and pinion described in chapter 7, then the diameter of the pinion is  $\Phi D$  in figure 10.4, and  $F_B$  is the force applied to Safesetp when a person pulls himself upwards plus a contribution from the mass of Safesetp [73].

The torque would then be given by:

$$T = \frac{F_B \Phi D}{2} \quad (10.3)$$

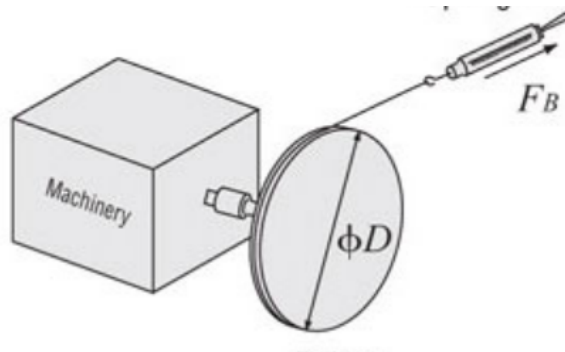

**Figure 10.4:** Force applied to shaft [73]

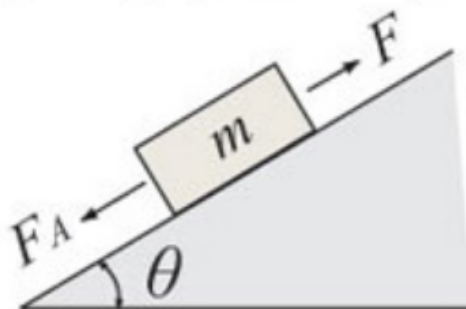

**Figure 10.5:** Forces when inclined surface [73]

In figure 10.5,  $F_A$  would be the force from someone pulling themselves forward when there is an incline, and  $F$  is then the force the motor needs to resist movement with.  $m$  is the mass of Safestep and  $\theta$  is the inclination of the banister.

$$F = F_A + mg \sin \theta \quad (10.4)$$

$g = 9.81 \frac{m}{s^2}$ , is gravitational acceleration.

$F_B$  from figure 10.4 is equal to  $F$  from figure 10.5

By inserting equation 10.4 into 10.3, the torque that the motor would need to withstand is:

$$T = \frac{(F_A + mg \sin \theta) \phi D}{2} \quad (10.5)$$

## 10.4 I<sup>2</sup>C protocol

The inter-integrated circuit (I<sup>2</sup>C) protocol is a protocol for serial communication and was developed by Siemens in 1982, originally intended for connecting a CPU to peripheral chips in a TV [74]. I<sup>2</sup>C consists of two signals, a clock signal, SCL (serial clock, meaning that the protocol is synchronous) and a data signal, SDA (serial data), and it only requires one wire for each signal and multiple nodes can be connected to them. Therefore, the protocol allows for one or multiple master nodes to communicate with one or multiple slave nodes using the same two lines (SDA and SCL). I<sup>2</sup>C is used by the Adafruit AMG8833 thermal camera, which is a camera used in this thesis.

## 10.5 UART

UART stands for a universal asynchronous receiver transmitter. This means that it allows for serial communication (one bit at a time) between two devices without synchronization through the use of a clock signal (unlike I<sup>2</sup>C), and instead uses start and stop bits [75].

UART is not a protocol like I<sup>2</sup>C or Bluetooth. Instead, it is a physical component (an IC) originally developed by Digital Equipment Corporation. Arduinos have UART functionality built-in through dedicated rx and tx pins, and it is utilized in Safestep. The receiver (Rx) of one device needs to be connected to the transmitter (Tx) of another and visa versa. Through this connection, data is transferred sequentially, one bit at a time.

## 10.6 Bluetooth protocol

Safestep would be moved up and down the staircase, so having wires connected between Safestep and the external device that forwards data to a device with the Safestep app installed is not desirable. Bluetooth is a standardized communication protocol for serial communication, wirelessly, and can achieve the desired form of communication.

Bluetooth originates from the Swedish company, Ericsson. Since 1998 it has been managed by a special interest group (SIG) [76].



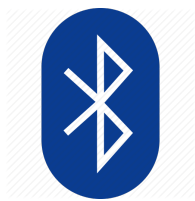

A Bluetooth profile is a definition of applications (e.g hands-free headsets or wireless gaming controllers) and behaviour of Bluetooth devices when they communicate. Bluetooth devices communicating with each other must support the same profiles. The Bluetooth profile used by Safestep is the serial port profile (SPP). SPP emulates a wired serial communication interface, such as UART. This allows for much greater distances when transferring data, as illustrated in figure 10.6, which shows two Arduinos communicating both with wires and with Bluetooth.

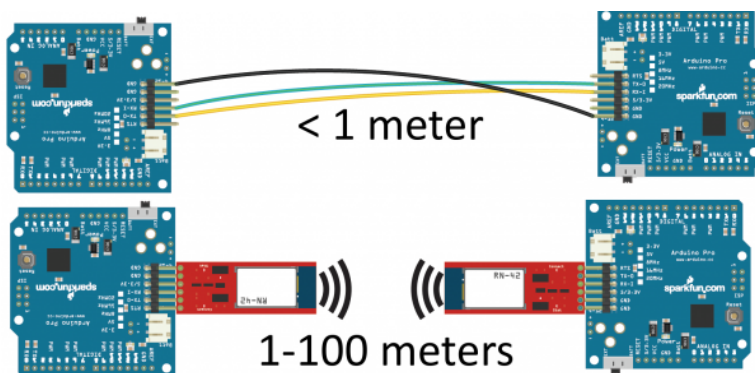

**Figure 10.6:** Serial communication using wires and using Bluetooth [77]

SPP functions between two devices (device A and device B), without any fixed master/slave roles [78]. Device A initializes a connection and device B accepts.

The data collected by Safestep needs to be protected. Bluetooth has a security troika, which different profiles apply differently. The troika consists of authentication, authorization, and encryption [79]. Authentication and authorization are about checking the identity of the device on the other end of the link, and whether or not this device should have access to the first Bluetooth device. Encryption secures the data and only devices who are approved will be able to decrypt it [80]. For use of SPP, all these are optional but support for authentication and encryption is mandatory so that it can be implemented if requested.

The Sparkfun Bluetooth Mate Silver is described in 11.2, and this modem uses the RN42 Bluetooth module which supports Bluetooth version 2.1 + EDR [81]. The recommended security for this version is mode 4, level 3 [82]. Mode 4 uses secure simple pairing (SSP) in which elliptic curve diffie-hellman (ECDH) key agreement is used for link key generation. A link key is an authentication key used to establish a connection between two devices and the ECDH key agreement is a way of generating and exchanging such a key. Level 3 means that an authenticated link key is required.

## **10.7 Summary**

This chapter provides some basic theory regarding the components used in this thesis and communication between them. This is not required to know, to understand how Safestep could work, but it could be used to achieve a deeper understanding.

# Chapter 11

## Hardware

Based on chapter 2, the candidates have chosen that monitoring a person's heart rate, temperature, stair negotiation time and activity level could make Safestep into a highly useful aid. To see what added value this can provide, it is necessary to have components that can achieve this. Chapter 9 presented different categories, and in this chapter, specific sensors will be presented, among other components. These components have been further worked within the thesis, to create desired functionality.

### 11.1 Arduino Nano

The Arduino Nano is an open-source electronics platform [83]. It is easy to use and has the possibility of connecting several components (e.g sensors and actuators) to its I/O pins. The Arduino Nano is a compact version of Arduino boards, which makes it more suited to be used in a prototype of Safestep. The pinout of the Nano can be seen in figure 11.1. It has many pins with different functions and the ones used in this thesis are the digital and analog pins. Some of these allow for use of PWM. The 3,3V and 5V power supply pins and Tx and Rx pins for serial communication using UART (see 10.5) and SCA and SCL pins for I<sup>2</sup>C communication.

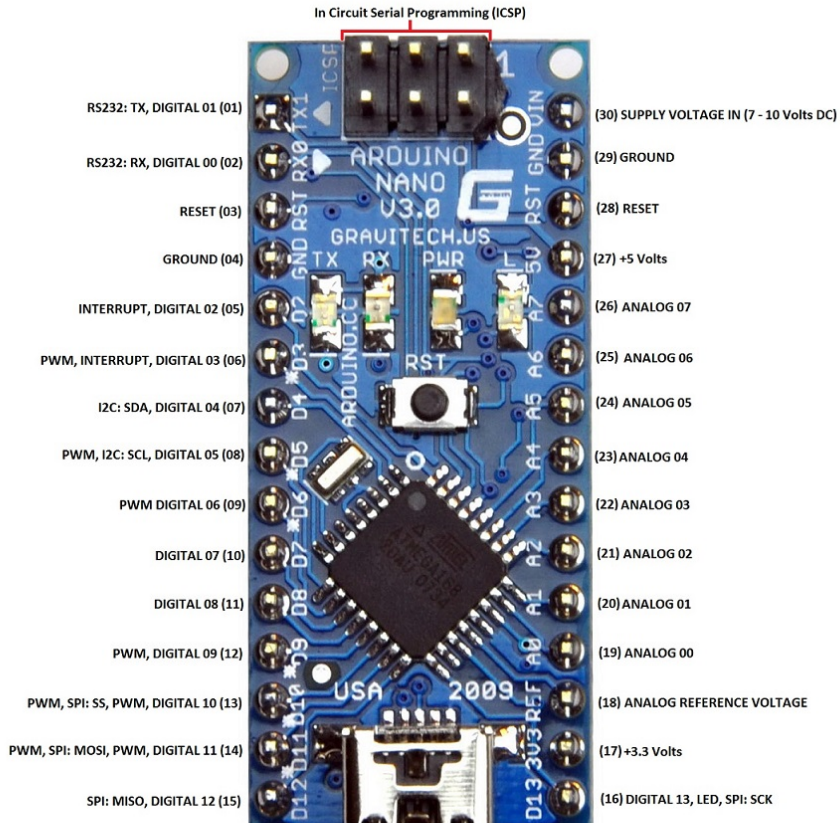

### Arduino Nano V3 - Pin Description

[www.CircuitsToday.com](http://www.CircuitsToday.com)

**Figure 11.1:** Pinout of the Arduino Nano [84]

The Arduino Nano has an ATMEGA328 microcontroller with a 32 KB flash memory, the clock speed of 16 MHz and operates on 5V.

Some of the main advantages were stated earlier in this section with ease of use and open-source. What also influenced the choice was that the authors of this thesis have experience using Arduinos and the support on online forums is vast. In total it serves the main purpose of testing and prototype the desired functionality of Safestep.

## 11.2 Sparkfun Bluetooth Mate Silver

To convey information about the elderly individual to next of kin or health personnel, a way of transferring this information is needed. The choice fell on using Bluetooth. There are other options like Zigbee [85], but finding the best protocol was not a focus, rather simply trying to make it possible to send data

To communicate statistics with health personnel and next of kin, the idea is to use a Safestep app, which presented in chapter 13. Safestep should pass sensor data and statistics to a stationary device that can forward it to the app. To communicate with the stationary device, a Bluetooth modem would be needed.

The Sparkfun Bluetooth Mate Silver[86], is a Bluetooth modem that allows for wireless serial communication between the Arduino Nano and an external device mounted at the top or bottom of the staircase. It uses an RN42, which is a Bluetooth class 2 module. Class 2 means that it can receive and transmit within a distance of approximately 10 meters. This distance may be too short for some staircases, which can be of great importance with regards to the alert of falls occurring. To increase the range a class 1 module could be used (the range is 100 meters), for example, the RN41 module which comes with the Sparkfun Bluetooth Mate Gold [87]. This decision was not of importance during this work since the results gathered from working with the Bluetooth Mate Silver is directly transferable to a Sparkfun Bluetooth Mate Gold.

The modem is seen in figure 11.2.

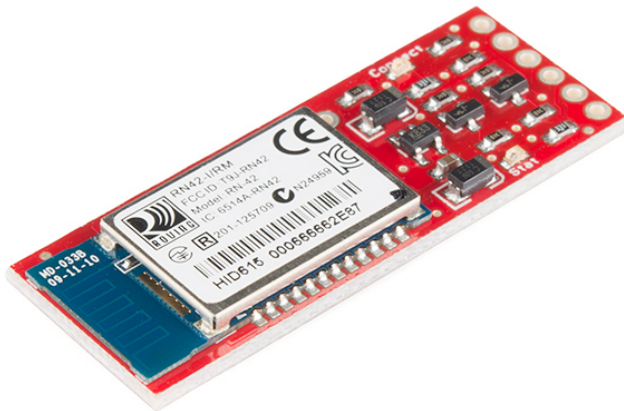

**Figure 11.2:** The Sparkfun Bluetooth Mate Silver [86]

The RN42 uses the v2.1 + EDR version of Bluetooth and allows for SPP (serial port profile). The SPP is also a profile supported by the MIT app inventor that was used to develop the Safestep app. MIT app inventor is described in section 13.2

### 11.3 DRV8871 motor driver

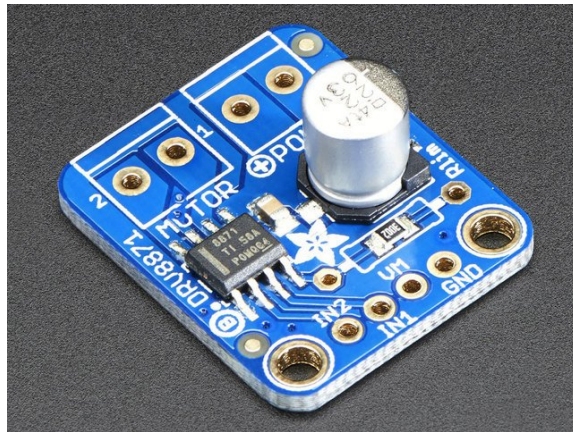

Figure 11.3: The DRV8871 motor driver [88]

When using a bidirectional DC motor with an Arduino Nano, a motor driver is needed. With it, moving forward and backward is possible and it can prevent damage to the Arduino due to current drawn by the motor. The driver used is the DRV8871 from Adafruit [88]. It supports PWM and can run a motor in two directions. It allows for use of motors with power voltage between 6.5-45V and a peak current of 3.6A.

### 11.4 Sparkfun single lead heart rate monitor

The Sparkfun single lead heart rate monitor uses the AD8232 IC from Analog Devices [89], and can display a person's ECG (electrocardiogram). Sparkfun has developed a ready to use component.

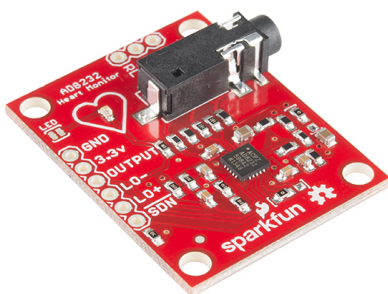

Figure 11.4: The Sparkfun single lead heart rate monitor [90]

The Sparkfun single lead heart rate monitor has a cardiac monitor configuration, as displayed in figure 11.5. This is a configuration that will monitor the shape of The ECG curve, but it requires that the individual being monitored sits still during the measurement.

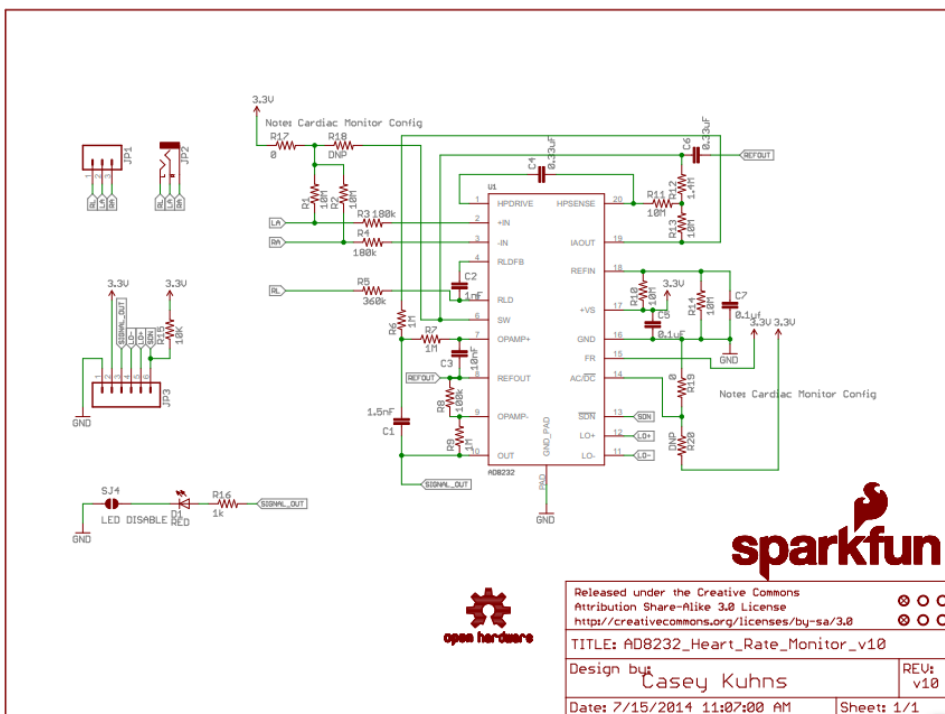

Figure 11.5: The cardiac monitor configuration used by Sparkfun [91]

Sitting still is not an option when negotiating stairs, so a more suitable configuration would have been the circuit for heart rate measurement at the hands, as shown in figure 11.6. The key difference between these two circuits is that 11.6 will have a more narrow band-pass characteristic, this is because the placement of the electrodes in the hands will result in much more noise due to the muscle activity from the upper body and arms. By using a narrow band-pass, the heart signal can be separated. With it, it is not possible to retrieve the complete ECG curve, but it is possible to obtain the heart rate by measuring the time between QRS complexes.

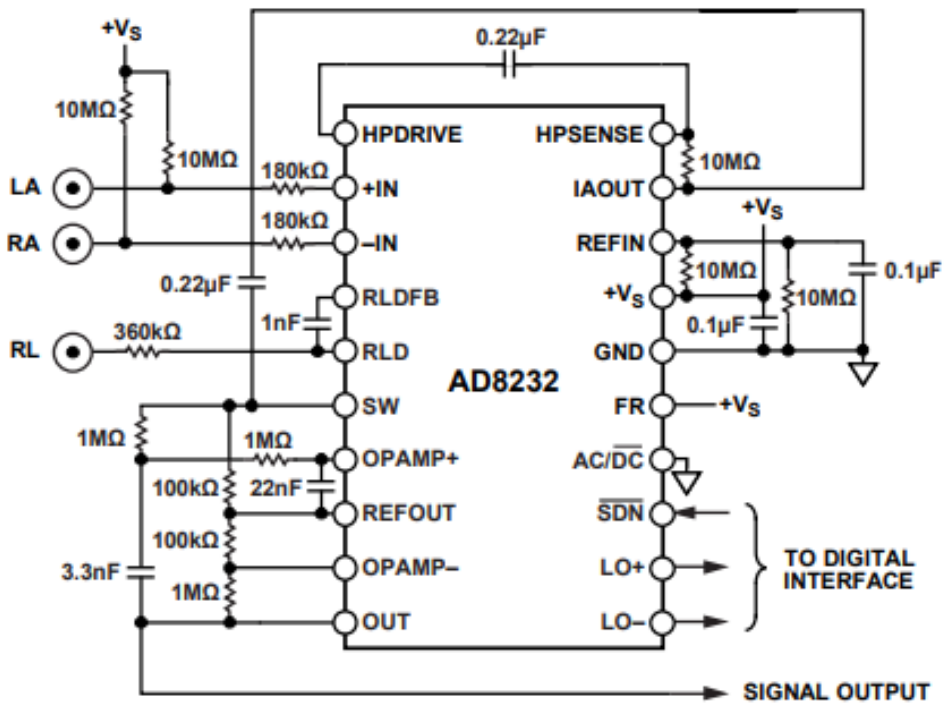
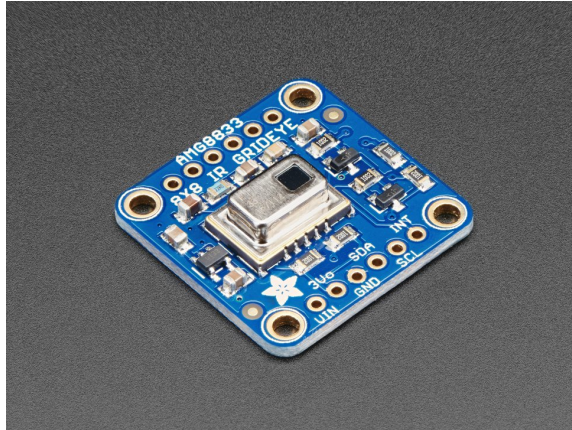

Figure 11.6: Circuit for heart rate measurement at hands [92]

There might be a better solution still, the BMD101 cardiochip from Neurosky [93]. The choice fell on AD8232 because of the limited time available to complete the thesis, and products from Sparkfun are supported more on discussion forums and have more examples available online. But with further development, the BMD101 would have been tested.



## 11.5 Adafruit AMG8833 thermal camera



**Figure 11.7:** The IR camera from Adafruit [94]

The Adafruit AMG8833 thermal camera captures the infrared radiation coming from whatever is in front of its viewing field and is shown in 11.7. The AMG8833 is made by Panasonic, operates at 3.3V and gives an 8x8 matrix of pixels, each of which gives a temperature reading of their specific viewing field [95]. The choice of this component was influenced by availability and support. Products from Adafruit have many example codes and hook up guides available online.

## 11.6 LM35 temperature sensor

To measure the temperature in the palms, the LM35 from Texas Instruments [96] was chosen. The output voltage has a linear proportionality with degrees Celsius, a change in the output of 10 mV means a change in temperature of 1°C [96]. At 25°C, it has an accuracy of 0.5°C, the temperature range it can measure is from -55 to 150°C. An error due to accuracy could be rectified with high precision. As long as the returned value is the same for a corresponding true value every time, i.e having high precision. If this is the case, then a change in body temperature is still detectable.



## 11.7 Force-sensitive resistor

With the force-sensitive resistor (FSR) it is possible to detect when a person tries to push Safestep forward. This could be used to activate the DC motor and move Safestep along the banister so that the user does not have to move Safestep on his/her own, and it can be used to detect if someone has fallen.

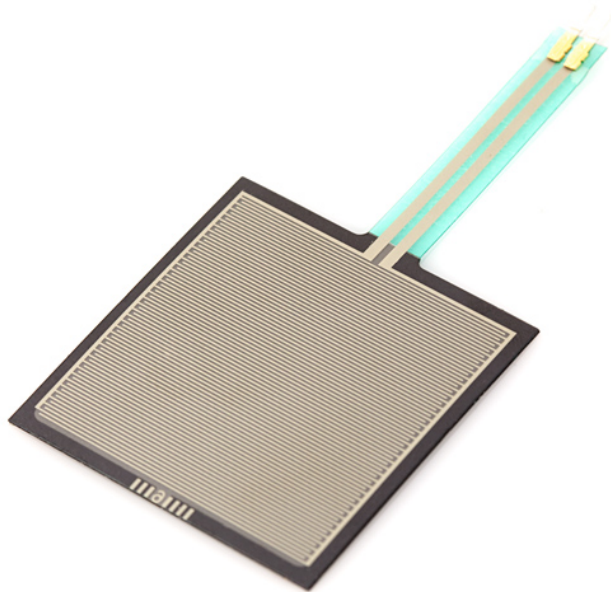

**Figure 11.10:** A square force sensitive resistor [98]

The datasheet for the FSR [99] shows different resistors between the ground and FSR. The choice of this resistor effects what range the FSR can detect. The force sensitivity range is approximately 100 gram - 10Kg, as shown in figure 11.11. The scale used is logarithmic, and the change from greater than 100 K $\Omega$  to around 10 K $\Omega$  happens when applying a small amount of force.

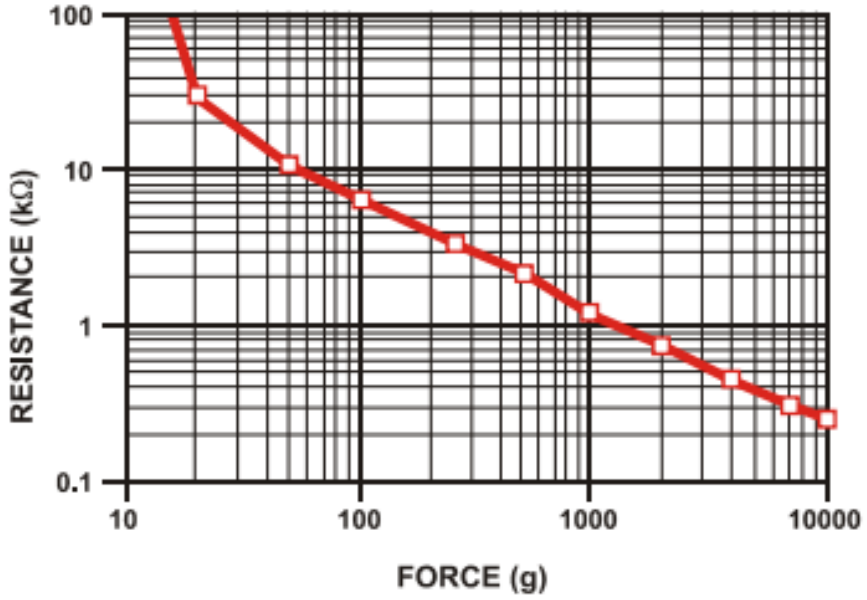

Figure 11.11: Force vs. resistance [99]

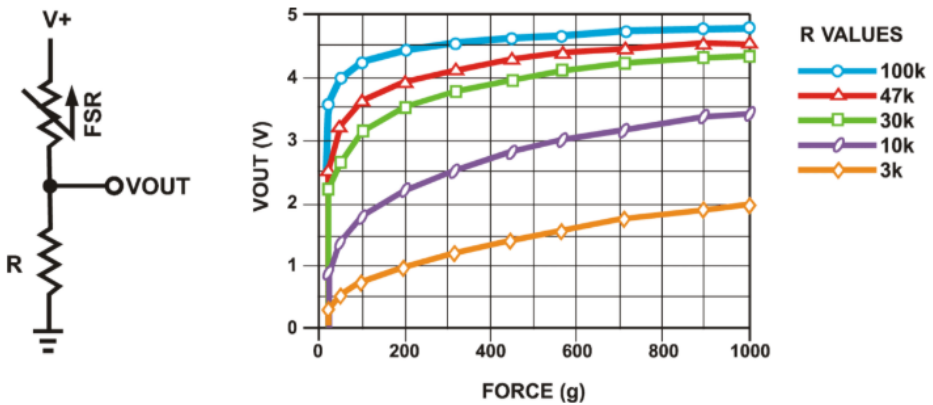

Figure 11.12: Change in output voltage with change in force due to different voltage divider circuits [100]

## 11.8 Reed switch

A change in how long it takes for someone to negotiate a staircase can be an indication of functional decline, as described in chapter 2. To measure the time a person takes to walk up or down, a reed switch can be activated at the top and the bottom of the stairs. A timer will start when the reed switch is activated by one of the two magnets installed in the banister (one at the top and one at the bottom) and it will stop when the switch is activated by the other magnet. A reed switch is seen in figure 11.13



Figure 11.13: Reed switch [66]

## 11.9 Energy system

Safestep would need to be powered. When working with the different components, power was supplied through the use of a Mini-B USB cable connected to the computer and a 9V battery. This was used to be able to test the components. The school shut down before this could be worked on further, but since the stages of development covered by this thesis do not require an optimal energy system, it is instead discussed to some degree in chapter 16.

## 11.10 Discussion and summary

It is important that the different functionalities of Safestep, adds value to it. What is value varies from person to person, but the functionalities can be tested. Some components are also mentioned in this chapter, as potential alternatives, should it be needed. The focus has been to choose components that could be used to make a functioning prototype. With them, it is possible to try out different functions and see if they are worth having. For that reason, it is possible that choosing a different component at a later stage would be beneficial, as long as it can provide the same functionality as the part it replaces.

Components were purchased with the intent to rapidly test and prototype. At a later stage in development, further details need to be considered, e.g price and more specialized components could then be chosen.

As mentioned in chapter 2, the use of cameras in people's homes could be an invasion of privacy that some might not accept, but the AMG8833 thermal camera has the benefit of displaying an infrared image, and not a detailed picture that more easily reveals a person's identity.

By using both the thermal camera and the LM35 it is possible to obtain information about a person's body temperature based on different principles, ensuring better statistics to assess a person's body temperature. This chapter demonstrates the components used for further development of Safestep, based on chapter 2 and chapter 9.

# Chapter 12

## Suggested design of the total system

In this chapter, a description of how parts of the system in Safestep would work is presented. This is done by explaining a selection of implemented functionalities and the *Motor* class. These are described in detail, while some of the remaining classes are described in less detail. All classes and codes are included in appendix B . Parts of the system planned to implement are described in chapter 14.

Figure 12.1, shows how Safestep could look installed in a staircase. The banister follows the stairs ascending with an even height difference to the stairs. The arrows point to the likely placement of the reed switch and DC motor, the LM35 temperature sensor, the FSRs, and the electrodes to the heart rate monitor and the thermal camera. At the top of the staircase, a magnet is drawn, this interacts with the reed switch.

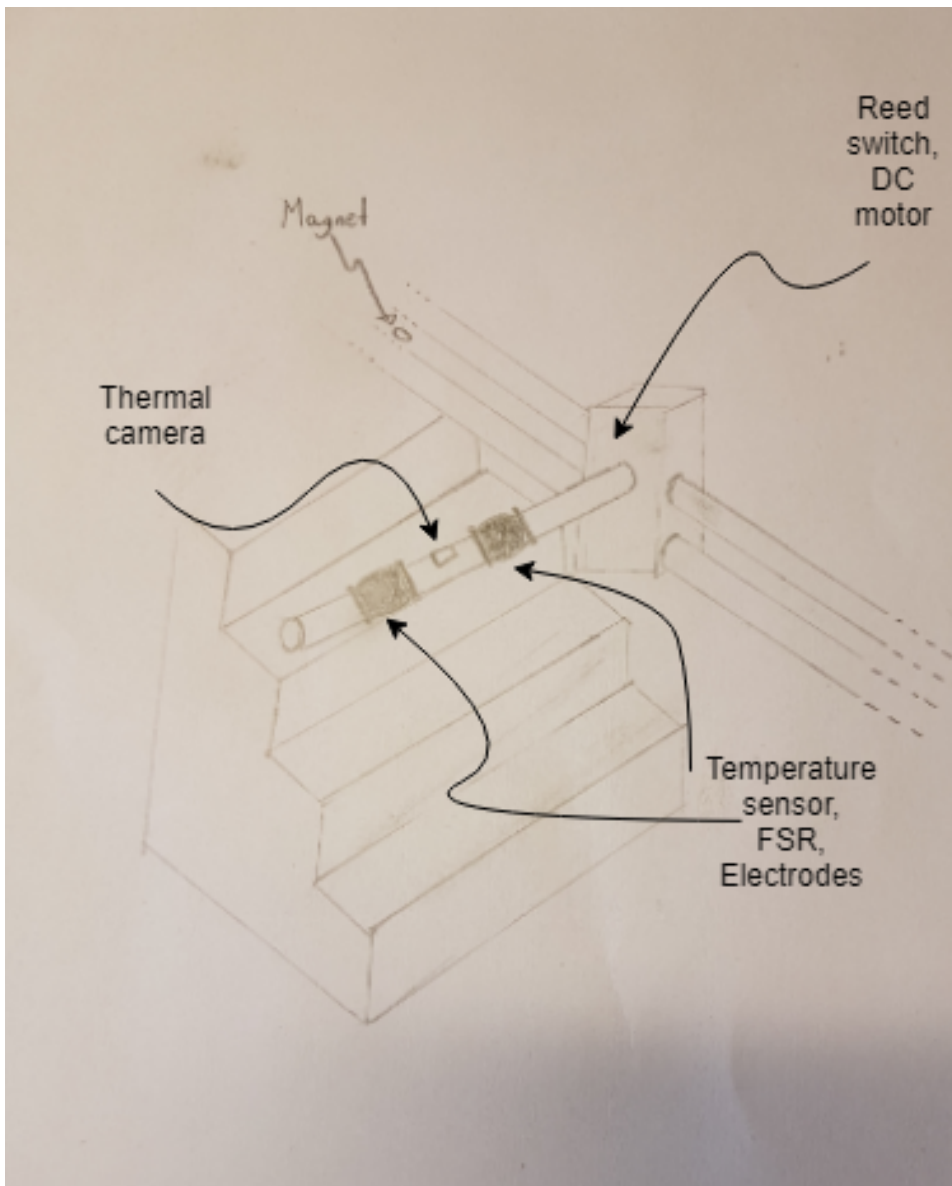

**Figure 12.1:** Safestep

Figure 12.2 illustrates the system developed, with monitoring of temperature, heart rate and stair negotiation time.



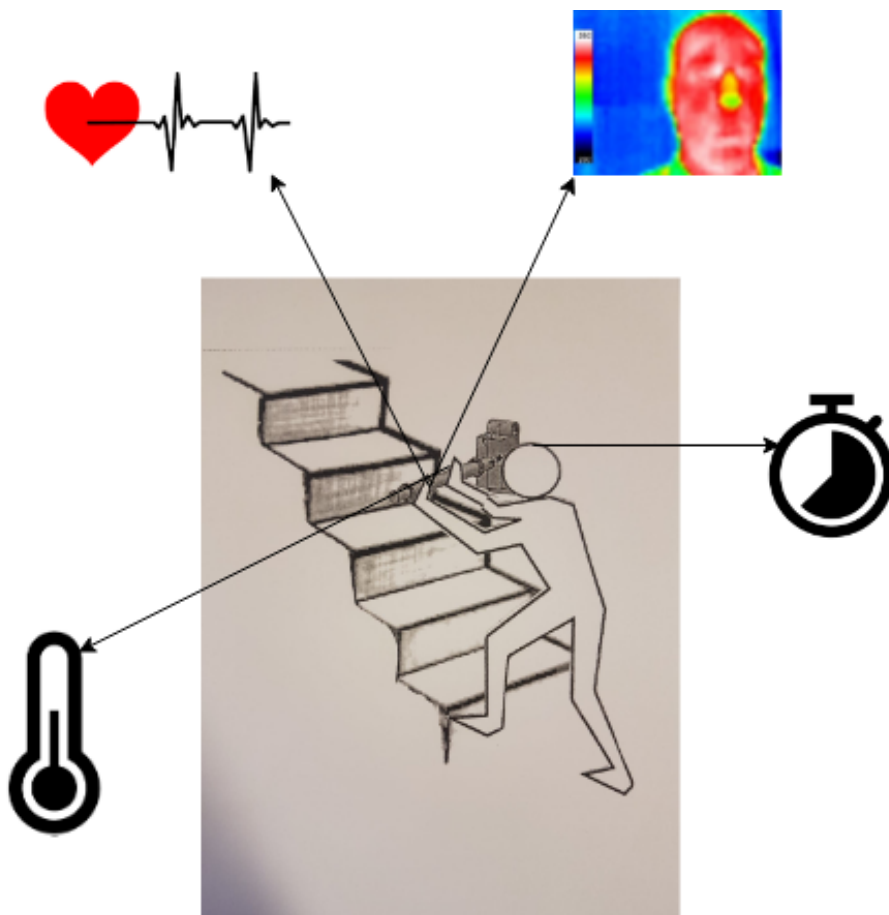

**Figure 12.2:** The suggested system for safestep

## 12.1 Choosing the system

In chapter 2, what could be monitored for an elderly person is described. Prior to the involvement of health professionals, the safest assumption to make is that changes in vital signs and physical activity affect a person's health. Safestep is intended to monitor pulse, body temperature, stair negotiation time, the occurrence of falls, and activity level. The activity level is part of what was not implemented, but it is described in section 14.1. The sensors described in chapter 11 can be used to monitor these, and in this chapter comes a description of how these sensors could interact with their surroundings and parts of the code used to make it happen.

## 12.2 How it works

The complete system with sensors, actuators, a microcontroller, and the interaction between these components is shown in figure 12.3. The interaction between the sensors and the physical world happens through the actions of the individual operating Safestep and magnets placed at the top and bottom of the staircase. The sensor data registered can be collected by the Arduino and processed into useful information that is passed on to an external device via Bluetooth and from there forwarded to someone who has a Safestep app installed on their phone.

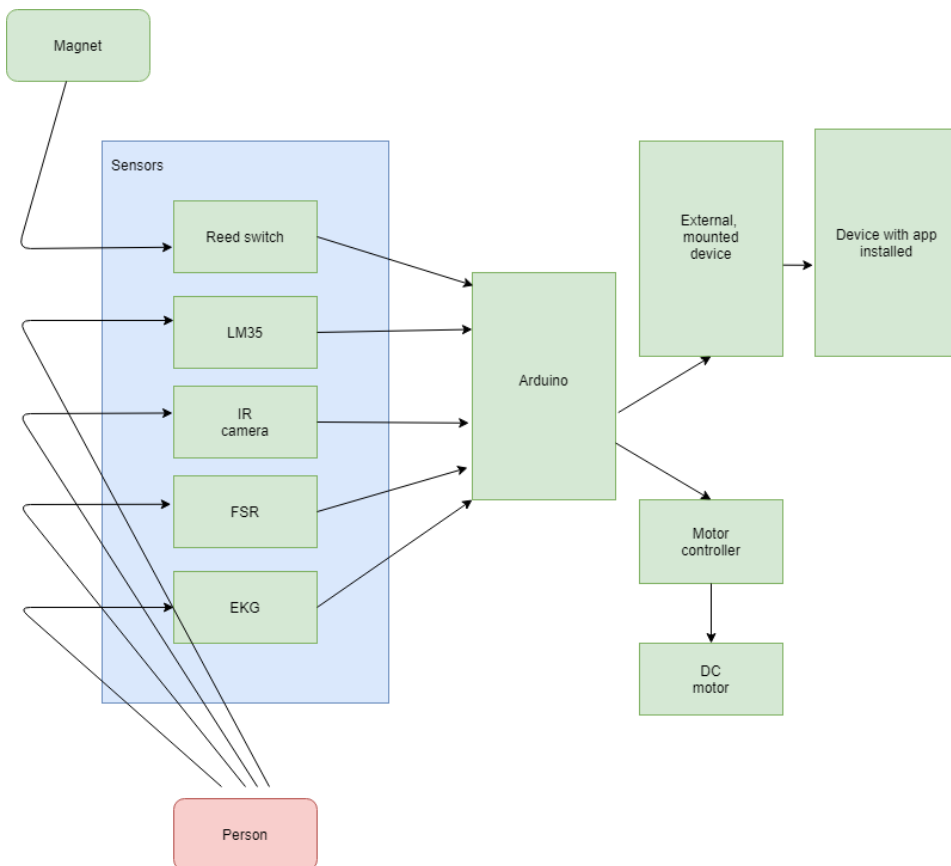

**Figure 12.3:** Diagram illustrating the system controlling Safestep

As seen in figure 12.3, the input for all the sensors, except the reed switch, comes directly from the person holding and operating Safestep. The LM35 senses temperature through the hands, the AMG8833 thermal camera detects temperature using infrared radiation radiating from the face, the heart rate is measured through the electrodes connected to the Sparkfun single lead heart rate monitor - AD8232 and the FSR is used for motor control and fall detection. The reed switch is the only sensor that responds to something

else than the individual. It interacts with the magnets placed at the top and bottom of the staircase, allowing for time measurement of ascending and descending. The reed switch is also used when detecting falls.

In the following, how time is measured, how falling is detected and an example of a class (the *Motor* class) is described, using flow charts and parts of the code used to accomplish it. This is to give a better understanding of how Safestep could operate. All of the code written is included in appendix B.

## 12.3 Detecting someone who falls

To detect when someone has fallen, two criteria need to be met. The two criteria are the detection of someone walking in the stairs, and that the person has let go of Safestep. This is done using the reed switch. The reed switch check that Safestep has passed one magnet, but not the other, with the, *is\_walking()* function, and whether or not the FSRs are detecting contact using the *loop()* function. Figure 12.4 shows the flow chart of how the detection of someone in the staircase happens. Much like how time measurement is performed, described in chapter 12.5, the reading of the reed switch determines the presence of someone. If the reed switch has passed one magnet, but not the other, then the conclusion from this function is that someone is in the stairs. It is the *proximity* function of the *Timer\_Func\_And\_Reed\_Switch* class that is used to read the reed switch.

The *is\_walking* function showed in figure 12.5 is run inside the *loop* function that checks both the criteria for fall detection. Figure 12.6 shows the process that is used to detect falling. It includes the initialization of necessary parameters, and then the loop that checks the criteria for falling to have occurred, with the *loop* function of the *FSR* class and the *is\_walking()* function. The value returned by the *loop* function of the *FSR* class is compared to a threshold value. This is set to 20 in figure 12.7 as an arbitrary, low value. What this needs to be is yet to be discovered. While working on this, it was seen that the FSR could read some pressure values above zero without a person holding on the Safestep. Therefore, the threshold was not set to 0.

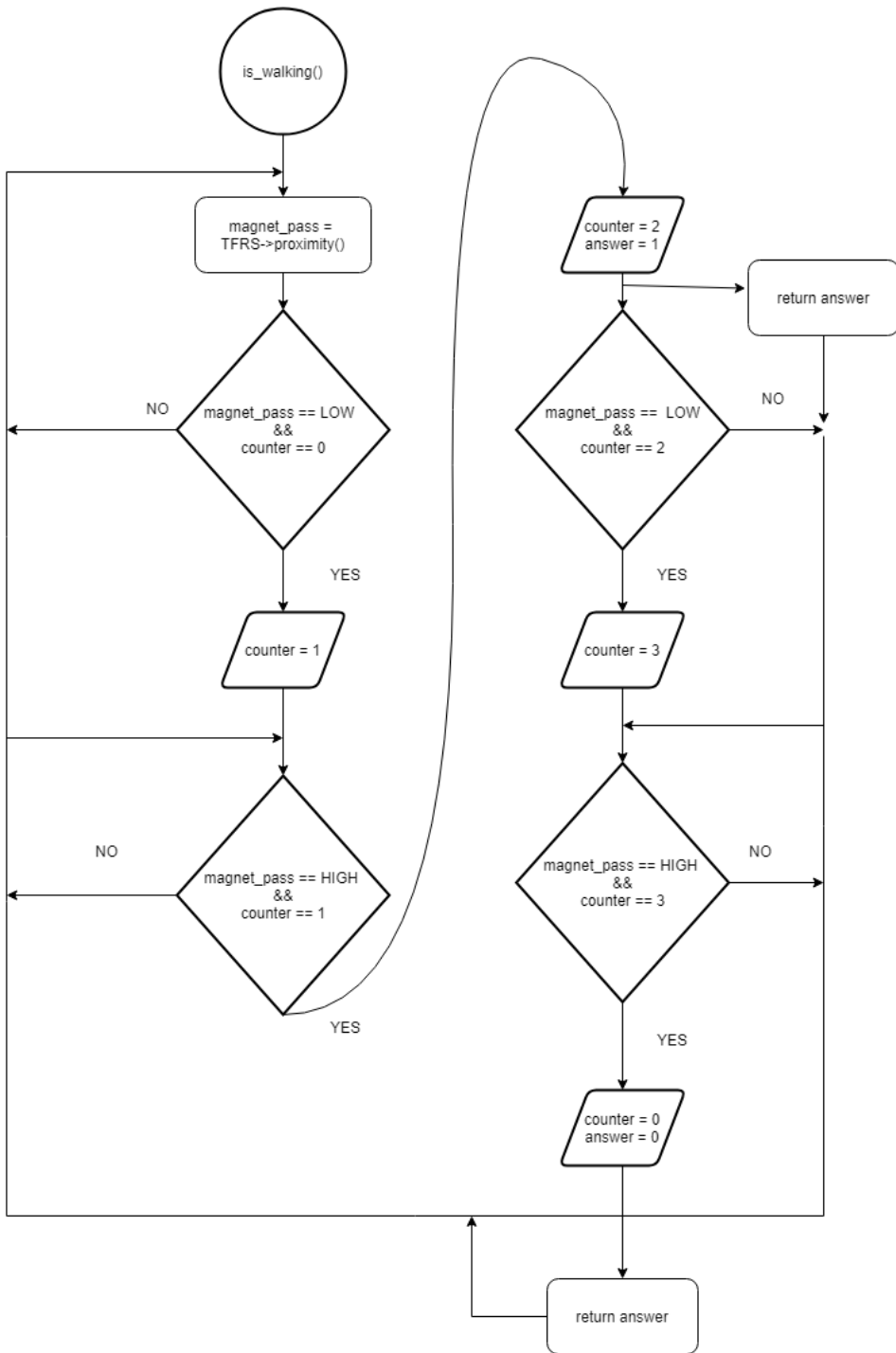

**Figure 12.4:** Flow chart for how to detect if someone is walking in the stairs

```

int Falling:: is_walking()
{
    passing_of_magnet = TFRS->proximity();

    if (passing_of_magnet == LOW && counter == 0){ //check if near the first magnet,
        //if LOW it means the magnet is near
        counter = 1;
    }
    if (passing_of_magnet == HIGH && counter == 1){
        counter = 2;
        answer = 1; //Update answer here because this is when the person has passed the first magnet.
        //If updated when near the first magnet, then it could happen the person changes his mind
        // and does not use the stairs, then it should not alert a fall. And if the person changes
        //his mind and goes back down after passing the first magnet, then he will pass the same magnet again
        //which will update the value for answer to 0, and that is how it should be
    }
    if (passing_of_magnet == LOW && counter == 2){
        counter = 3;
    }
    //has now passed the second magnet
    if (passing_of_magnet == HIGH && counter == 3){
        answer = 0;
        counter = 0;
    }
    return answer; //if return 0, the person is not walking, if 1 person is still walking,
    //if returns 2 the first time walking the stairs since starting the microcontroller has not yet happened
}

```

**Figure 12.5:** Image shows the *is\_walking()* function

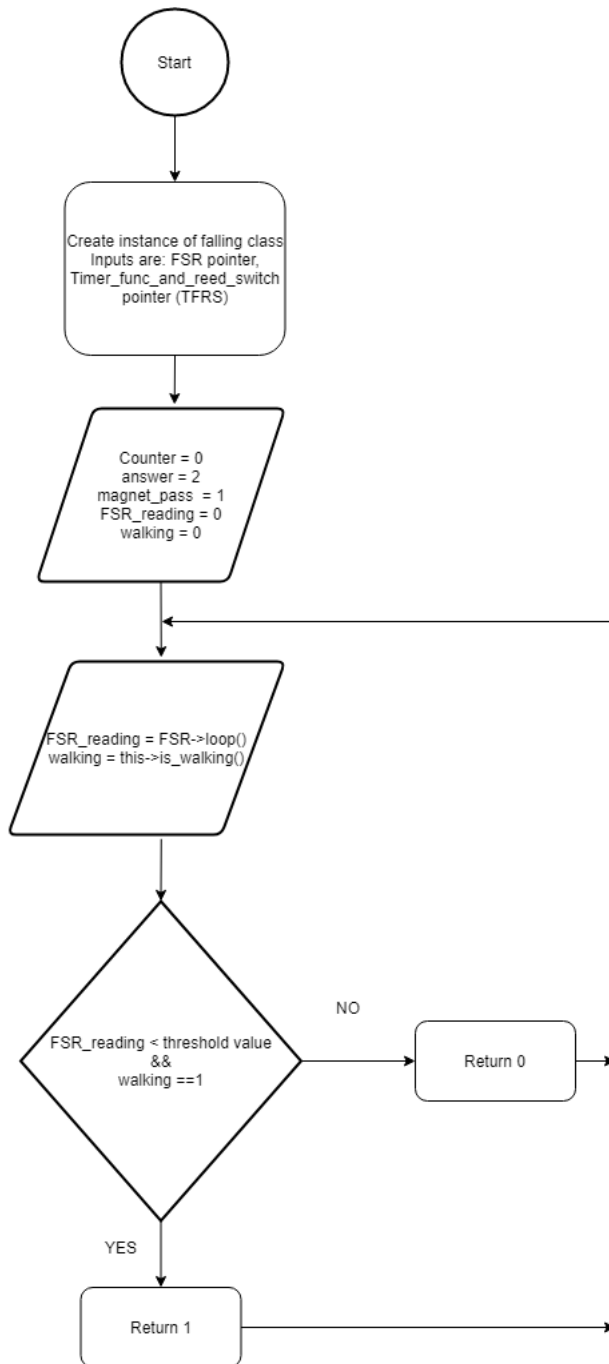

**Figure 12.6:** Flow chart for how falling is detected

```

int Falling::loop()
{
    FSR_reading = fsr->loop();
    walking = this->is_walking();
    if (FSR_reading < 20 && walking == 1) {
        return 1; //FSR_reading is checked against a value indicating
                //that the person is noy holding on, here it is set to 20
    }
    else {
        return 0;
    }
}

```

Figure 12.7: Image shows code that checks if someone has fallen

## 12.4 The Motor class

All classes written by the candidates have a setup function that runs once inside the *void setup()* part of the Arduino sketch (a program in Arduino is called a sketch). And they have a *loop* function that runs continuously inside the *void loop()* part of the sketch. The class for motor control, called *Motor* is used to illustrate the general layout of the classes.

Figure 12.8 is taken from the header (.h) file used for the *Motor* class. It declares the member variables and functions of the class, which are defined in an associated .cpp file. In this .h file, the variables are the pins used to connect the motor driver to the Arduino (*MOTOR\_IN1* and *MOTOR\_IN2* ), a pointer to an FSR, *fsr\**, instance (FSR has it's own class) and an integer, *motor\_speed*, that will hold the value the motor will receive to set its speed.

```

class Motor
{
private:
    const int MOTOR_IN1; //pin to motor driver
    const int MOTOR_IN2; //pin to motor driver
    FSR *fsr;
    int motor_speed;
public:
    Motor(const int MotorPin1, const int MotorPin2, FSR* fsr_ref); //the MotorPins must be PWM pins
    // for fsr_ref must first initialize an FSR object, then one must create an FSR* to that FSR object,
    //this FSR* must go in Motor constructor
    ~Motor();
    void setup();
    void loop();
};

```

Figure 12.8: Image from the .h file for motor control

The other classes are included in appendix B, and they have many similarities with the *Motor* class. Such as a constructor, destructor, variables and setup and loop functions. Figure 12.9 is taken from the .cpp file for the *Motor* class, with what is called a constructor, which is used to initialize an instance of the class, then a destructor that can delete the instance. The main part of this class is the *loop* and *setup* functions.

```
#include "Arduino.h"
#include "Motor.h"
#include "FSR.h"

Motor::Motor(int pin1, int pin2, FSR* fsr_ref) : MOTOR_IN1{pin1}, MOTOR_IN2{pin2}, fsr(fsr_ref), motor_speed{0}
{
}

Motor::~Motor()
{
}

void Motor::setup()
{
  pinMode(MOTOR_IN1, OUTPUT);
  pinMode(MOTOR_IN2, OUTPUT);
}

void Motor::loop()
{
  int FSRreading = fsr->loop();
  motor_speed = map(FSRreading, 0, 1023, 0, 255);
  analogWrite(MOTOR_IN1, motor_speed);
}
```

Figure 12.9: Image from the .cpp file of the *Motor* class

Figure 12.10 is a flowchart illustrating the initialization of a *Motor* instance. Done so using its member variables. Then a setup function declares the pins on the Arduino to be output pins. In the *loop* function, there is continuous reading of the FSR through its loop function (the FSR class has its own *loop* function), then these values are transformed into values that will be sent to the motor to instruct what speed it should have.



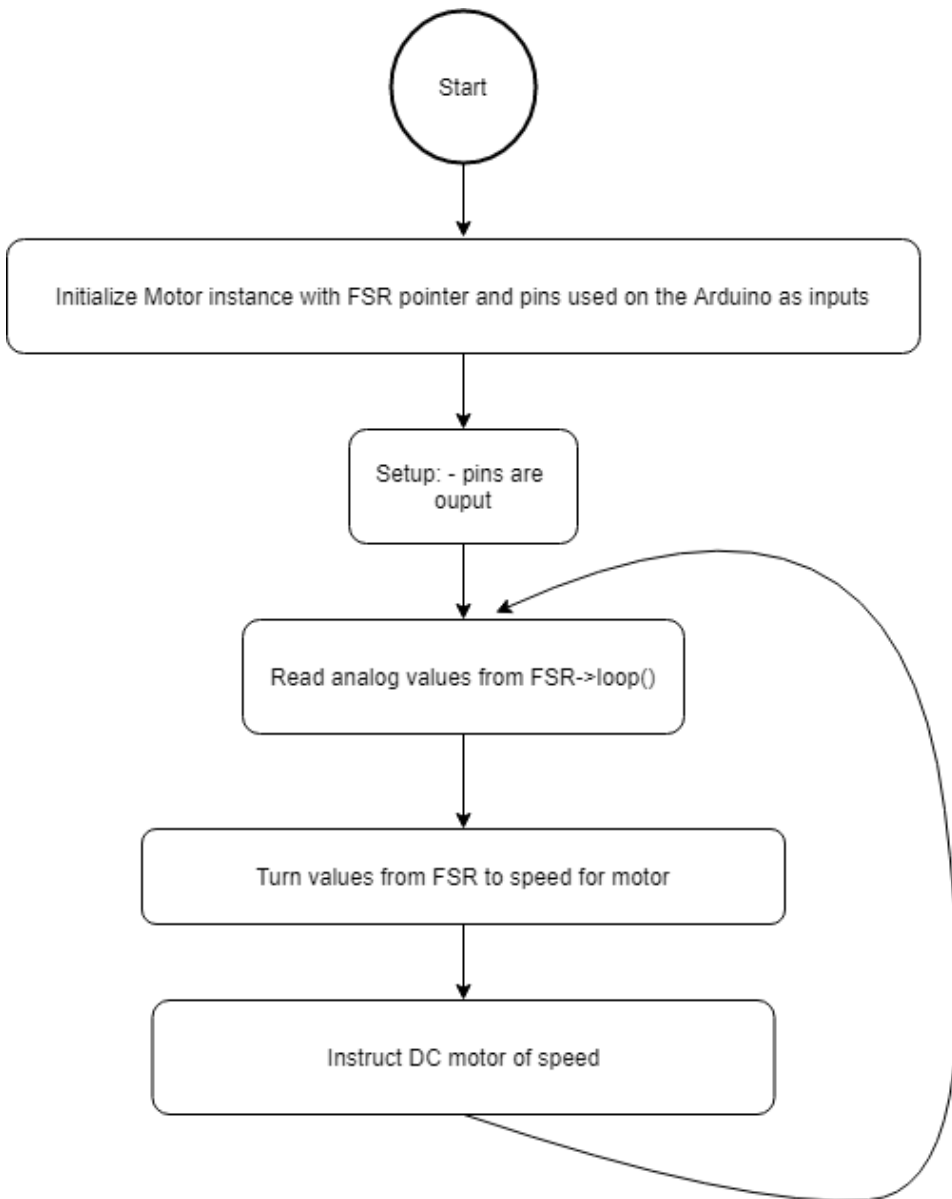

**Figure 12.10:** Diagram illustrating code for setup and loop function for motor control

## 12.5 Stair negotiation time

Figure 12.12 shows how Safestep measures stair negotiation time. Variables need to be updated as Safestep moves in the stairs. These are illustrated as *prox* and *counter* in the flowchart. After an instance of the class is created, variables are initiated to 0 and the pin used on the Arduino is set as an input pin, then the following loop function runs continuously:

1. The reed switch detects the presence of a magnetic field, the *counter* is set to 1, *Prox* set to 0, *time1* is set to the current time
2. *counter* is incremented when the magnet has been passed.
3. The magnetic field of the second magnet is detected, the *counter* is incremented, *Prox* set to 0, *time2* is set to the current time and *total\_time* is calculated
4. The second magnet is passed, the *counter* is set to 0 and the process can start over

Figure 12.11 shows the written loop function in the .cpp file to the class *Timer\_Func\_And\_Reed\_Switch*.

```
int Timer_Func_And_Reed_Switch::loop() {  
  
    int prox = this->proximity(); //use the this-pointer to call on its own member function  
    if (prox == LOW && counter == 0) {  
        time1 = millis(); //measure the time at first instance of magnet passing  
        counter = 1;  
    }  
  
    if (prox == HIGH && counter == 1){  
        counter = 2;  
    }  
  
    if (prox == LOW && counter == 2){  
        time2 = millis(); //time when passing second magnet  
        total_time = time2-time1;  
        counter = 3;  
    }  
  
    if (prox == HIGH && counter == 3) {  
        counter = 0;  
        return total_time; //Must return the time it has taken to store it for the statistics  
    }  
  
}
```

Figure 12.11: loop function that measures stair negotiation time

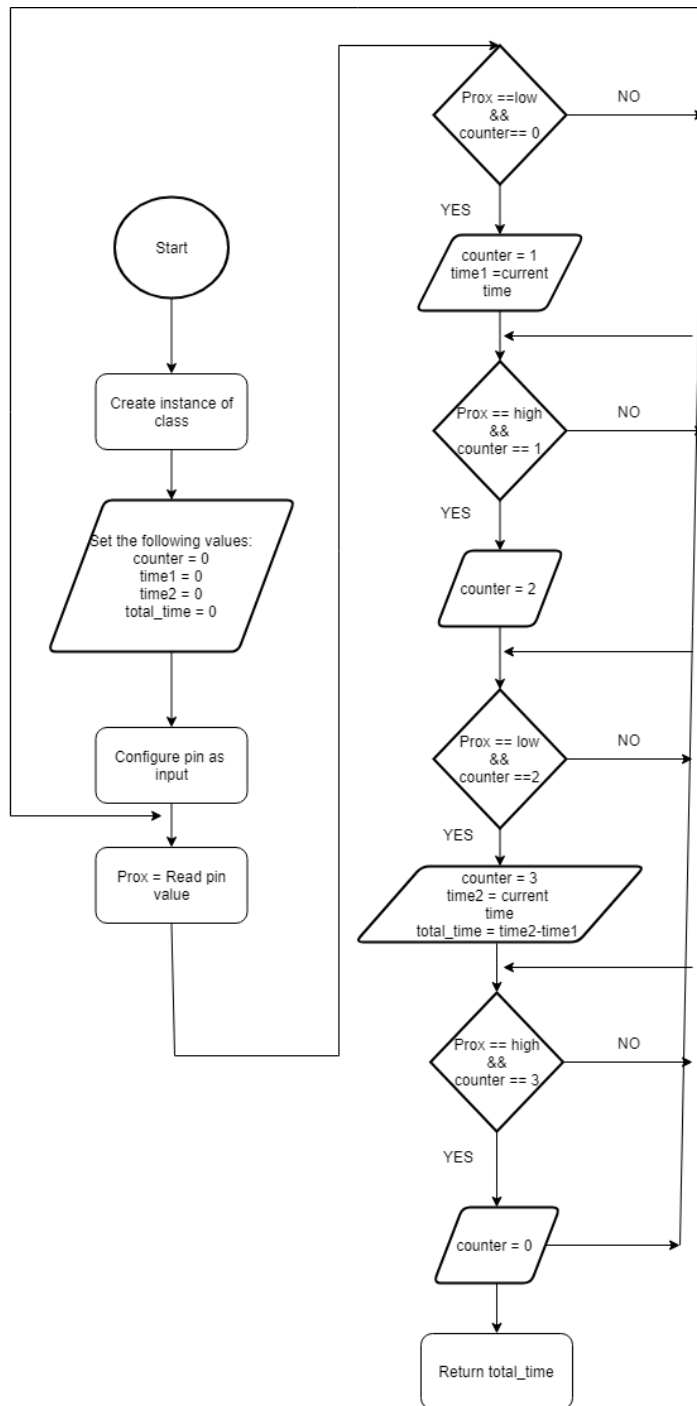

**Figure 12.12:** Diagram illustrating the code that measures stair negotiation time

## 12.6 The combination

So far in this chapter, some selected parts and code of the system have been presented. For the rest of the chapter, how to use the heart rate monitor-AD8232, FSR, AMG8833 thermal camera and the LM35 temperature sensor will be described, but in less detail. The code used to implement these is in appendix B. How the different components communicate is shown in figure 12.3.

### 12.6.1 Heart rate monitor

The heart rate monitor uses three electrodes. Two of them will be in contact with one hand, the third electrode with the other hand.

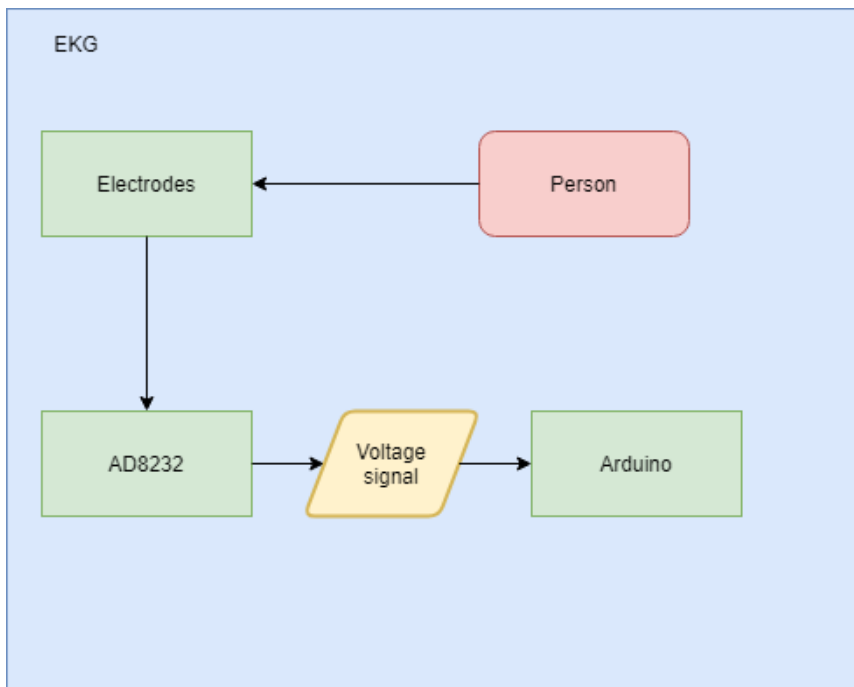
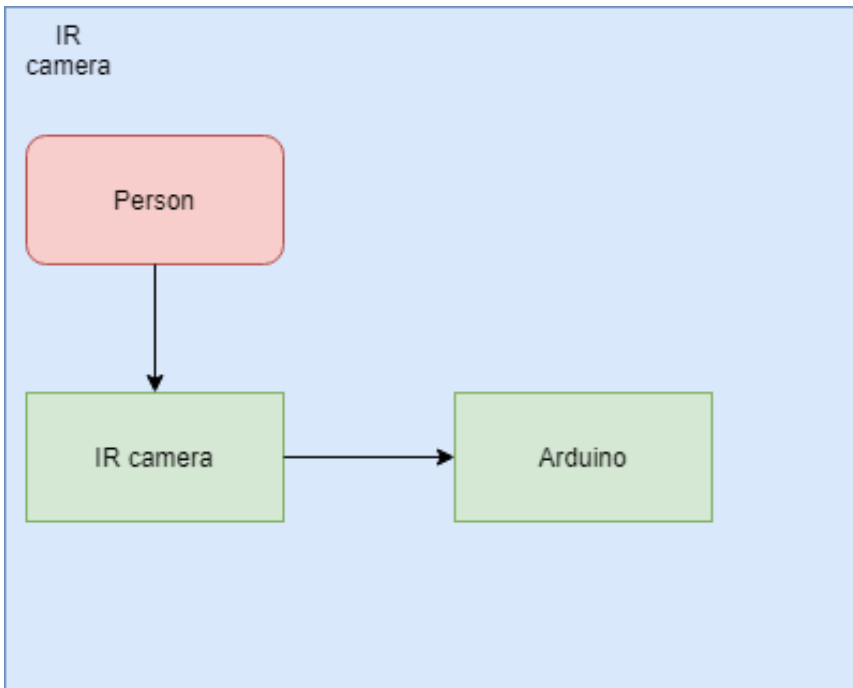

**Figure 12.13:** Diagram illustrating use of the EKG

As figure 12.13 illustrates, a person is in contact with the electrodes connected to the heart rate monitor. The Arduino reads a voltage signal from the heart rate monitor based on the electrical activity of the heart and can use this to plot an ECG. For the heart rate sensor, a class named *ECG* has been made. That includes a *setup()* function that sets the two pins used on the Arduino as input pins and a *loop()* function that simply reads the sensor values. Further development of this functionality is described in chapter 14.3.1.

## 12.6.2 Thermal camera

The thermal camera is likely best suited to place between the hands, and directed towards the person's face. The readings from the thermal camera are sent to the Arduino for processing as illustrated in figure 12.14. The thermal camera was tested using the Adafruit\_AMG88xx library, made by Adafruit. The sketch, `pixels_test`, displays all 64 pixel temperature values in a matrix. This was what the candidates used to test the thermal camera. Instructions are found in appendix B.



**Figure 12.14:** Diagram illustrating the use of the IR camera

## 12.6.3 FSR

Instances of the *FSR* class is used by functions in the *Motor* class described earlier. The *FSR* class has its *setup()* function and *loop* function. The *setup()* function sets the pin on the Arduino to be input, and the *loop* function continuously reads the values detected by the FSR. The interaction between a person, FSR and Arduino are shown in figure 12.15. The voltage varies with how much force the FSR experiences.

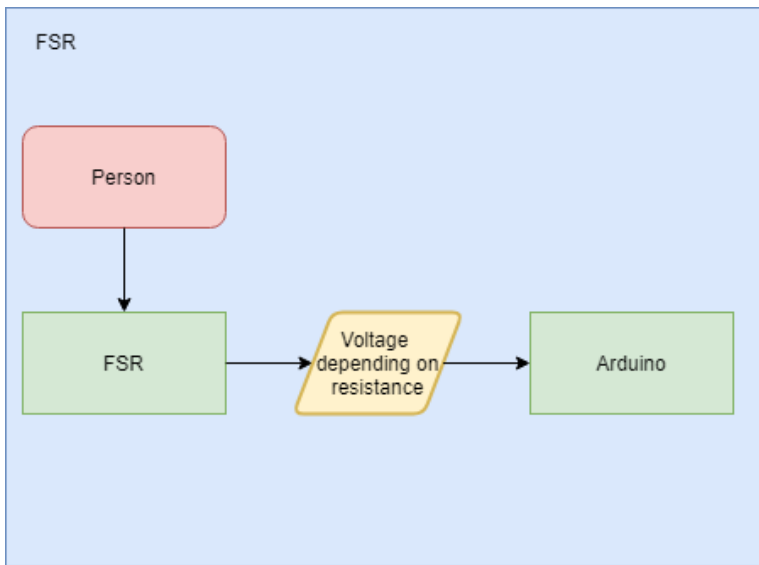

**Figure 12.15:** Diagram illustrating the use of FSR

#### 12.6.4 LM35 temperature sensor

The LM35 is used in many Arduino projects. Because of the linear relation to change in voltage and change in temperature of  $10\text{mV}/^{\circ}\text{C}$ , the temperature can easily be calculated. The Arduino reads the output voltage from the LM35, and conversion to  $^{\circ}\text{C}$  is done [101].

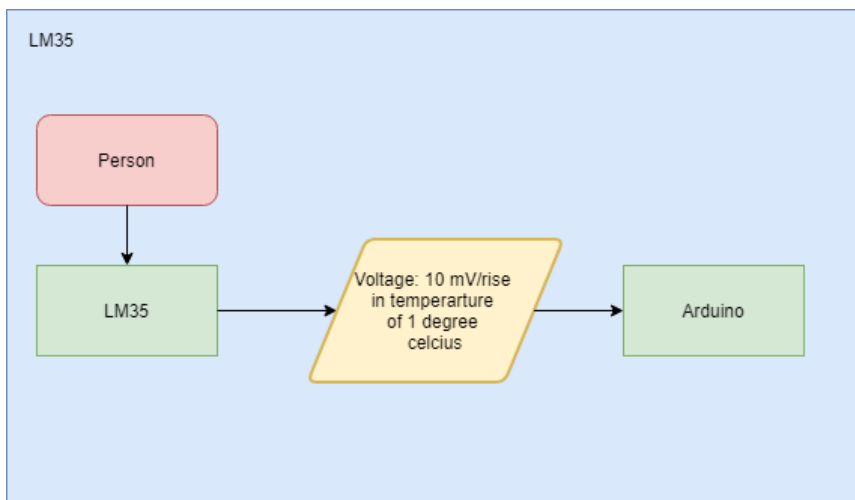

**Figure 12.16:** Interaction between a person, the Lm35 and the Arduino

## 12.7 Hook up guide

The candidates hooked up their components according to figure 12.17

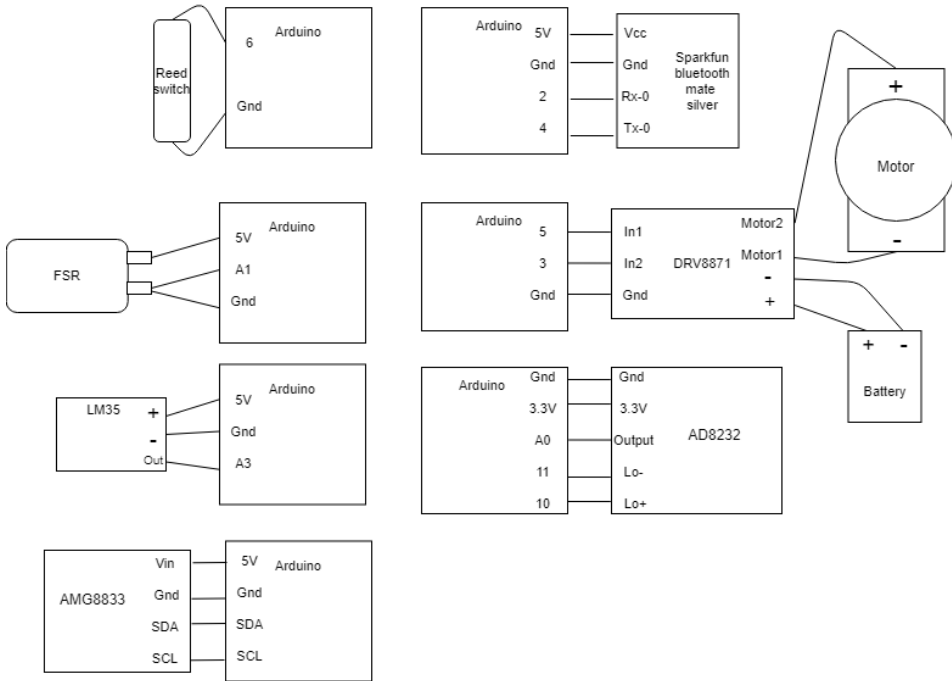

**Figure 12.17:** How the components were connected

Combined with the code in appendix B, this will perform as described in this chapter, both individual systems and combined. The Sparkfun Bluetooth mate silver is also shown here, and code for it is included in appendix B. When it was used, the candidates were able to send data between two terminals but did not send data from the Arduino to the Safestep App. The code is still included as it is most likely a base that can be further worked on.

## 12.8 Discussion and summary

The corona outbreak influenced this part of the thesis greatly, leading to the development of chapter 14. What could be implemented and how, is described there.

What has been implemented seems to work well, but it has yet to be put to test with a prototype installed in a staircase. The ability to detect when someone has fallen is possibly very important, as there could be severe consequences when this happens. This was fairly easy to implement, but it could possibly benefit from using more components when detecting a fall. Both to ensure that falling is detected, but also to reduce the risk of false alarms.

In addition to detecting when someone falls, this chapter describes the general layout of classes that have been made, how time measurement happens. The rest of what is implemented is briefly explained as well.



# Chapter 13

## App development

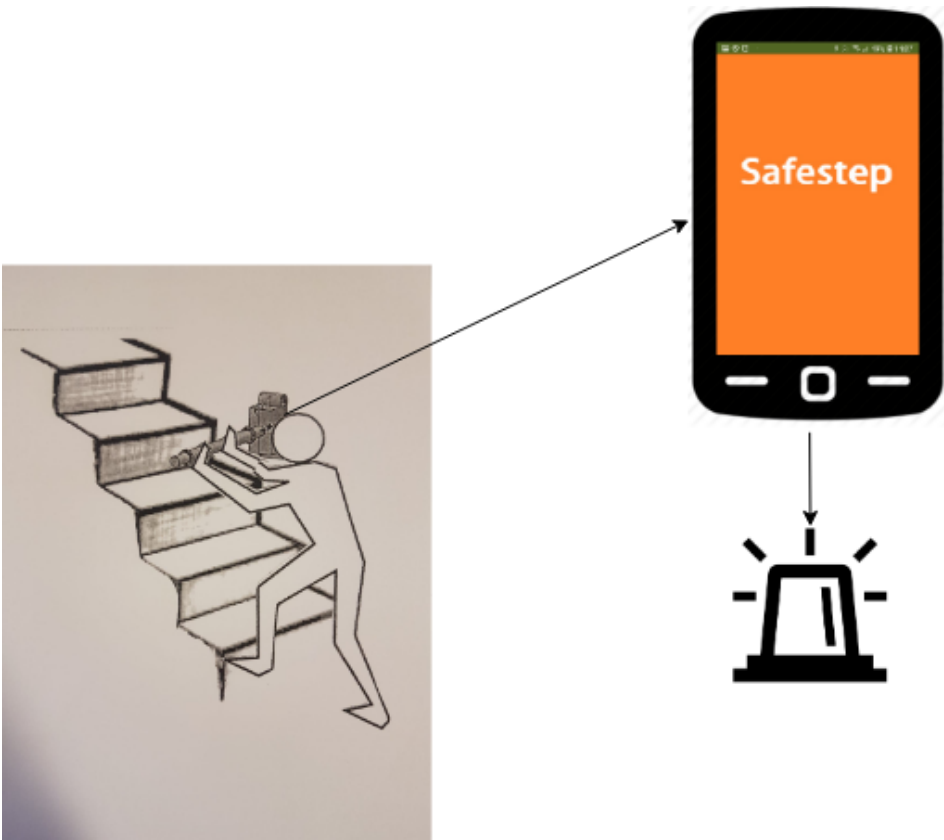

**Figure 13.1:** Safestep communicating with the Safestep app

An app connected to Safestep can show the health data measured from the user of Safestep. The information can be saved and presented in different ways to make it easy for the user of the app to understand it. Before the development of this app could start there was a need to identify the added value this could generate. The added value depends on who is using the app. Added value can also be experienced by the elderly using Safestep if he/she knows that someone has the app and can respond based on what the app informs about. The next of kin will be the ones with the most personal interest for the app. They have a personal connection to the user of Safestep. If someone's parent's health is starting to deteriorate it could be necessary to check up on them regularly, but this could be difficult to achieve if it is done over the phone, and it can be time consuming. With the app, they can have regular updates by accessing the data in the app and if something appears to be wrong they can act upon it. Added value for health professionals can be in the form of information about their patients, which can help them in deciding that an extra visit might be necessary. If the app informs that something has happened, and the health professional is required to act, the app can also detect if someone is not doing their job correctly if they choose to ignore the warning.

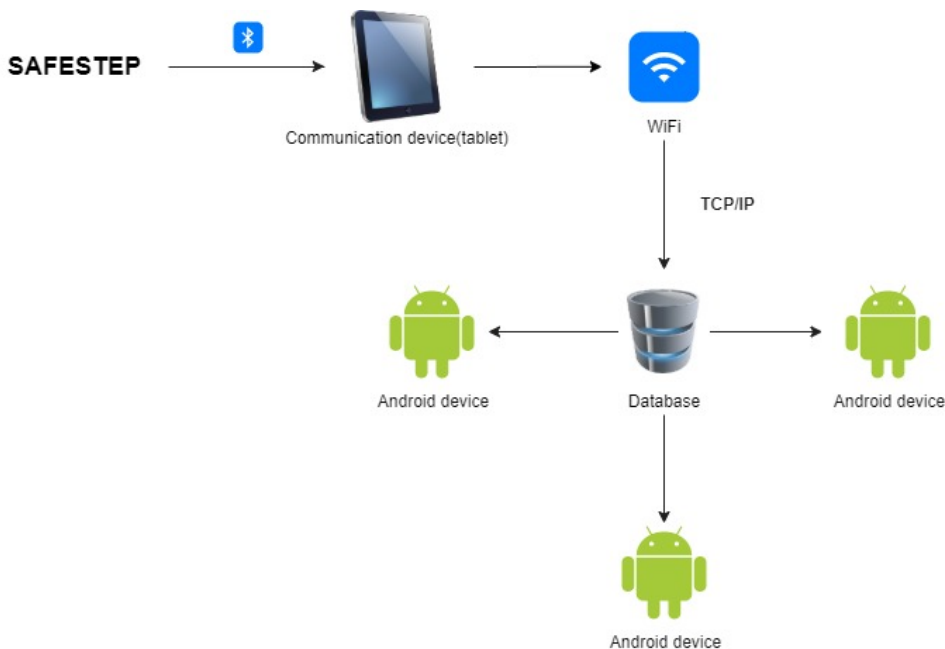

**Figure 13.2:** Communication from Safestep to app

To get the information from Safestep to the app for the different users, it can be used as a communication device as an intermediary. This is seen in Figure 13.2 where Safestep communicates with for example a tablet and then further communicate with the app installed on the relatives and the medics phones, with WiFi. The tablet used as a communication device can be placed at the bottom of the stairs and be used to interact with the users. Figure 13.3 contains a possible view on the tablet screen a certain time of the day or

after a certain number of times in the stairs. Getting this question can make the users feel a sense of security when someone cares and it can help the app to understand the health data better. Answering the question in 13.3 will give the health personnel a new factor to compare with the information and they can easier decide if the user is healthy or should be checked on.



Føler du deg frisk?

Ja

Nei

**Figure 13.3:** Are you feeling well?

When a fall occurs, it can be very important to act quickly. Safety alarms are worn by the elderly are connected to a security company that conveys contact with health personnel, and it is either the security company or a health professional that responds to the alarm. It makes sense to outsource the monitoring and control of alarms to a security company, since health professionals might be tied up with other tasks, and do not have the same resources to check if an alarm is real or not. For a security company to check if a person has fallen in the stairs, and Safestep reports it, it is not needed for them to have the app that also contains all the other data recorded. Therefore this is not a concern with regards to the app, but it must be implemented so that the alarm reaches the right people. Falling will also be reported via the app, more people will then be alerted, and the probability that help comes, increases.

## 13.1 Layout of the app

The schematics of the app as seen in figure 13.4 and figure 13.5 was sketched on paper to find a possible layout for the app. The layout and design had to be developed considering user friendliness and information with added value. The user interface has to be developed according to the intended users, i.e next of kin and health professionals. This means that it must be easy to use and not include language that the "average" person does not understand, e.g complicated medical terms.

Figure 13.4c will not be a page shown unless the user of the app has more than one patient to keep track of. Users of the app typically in need of this page are the health personnel with responsibility for several patients. From this page, it is possible to click on "Varsler" at the bottom of the page to open page 13.4d. Here any alerts of abnormal activity or abnormal measured values from the sensors are shown. If the page with alerts is closed (or never opened), the information page seen in figure 13.5 is shown. Here the data registered from the sensors will be illustrated in different ways. The pulse is here illustrated in different ways like the graph in the middle show the average pulse for each day in the month. The graph at the bottom shows at what interval the pulse has been in each day that week, with then max and min values at the top, and bottom of the orange columns. Then at the top the values for the max and min pulse on this day are shown. The user can choose which category they will view. Figure 13.5 shows the pulse, but can easily be switched to temperature and walking speed instead. It is also easy to access the alert page or other extra pages like notes, patient information and settings.

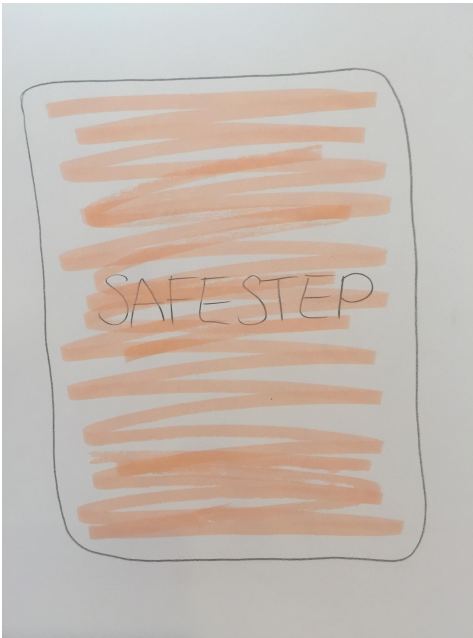

(a) Frontpage

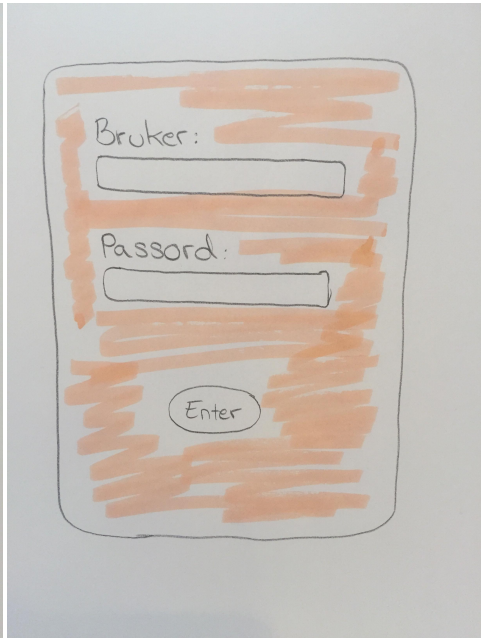

(b) Login page

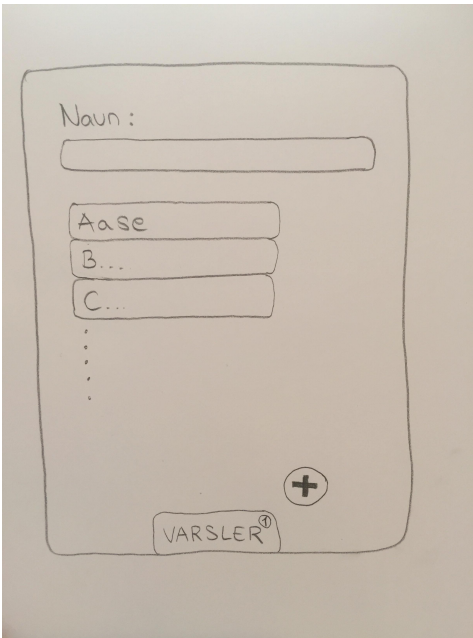

(c) Registered users on the account

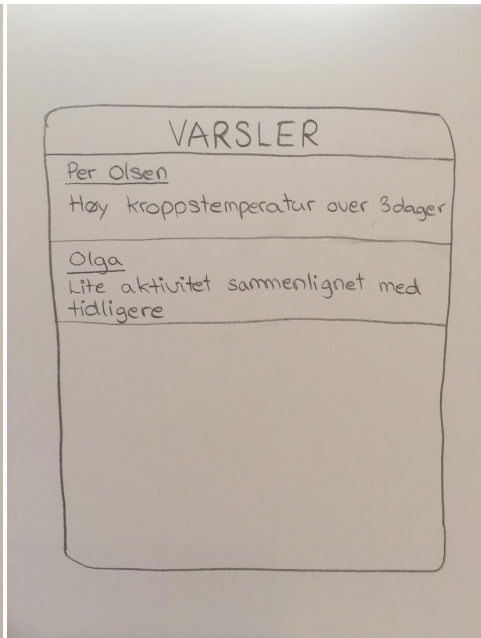

(d) Alerts

**Figure 13.4:** Schematics of the app

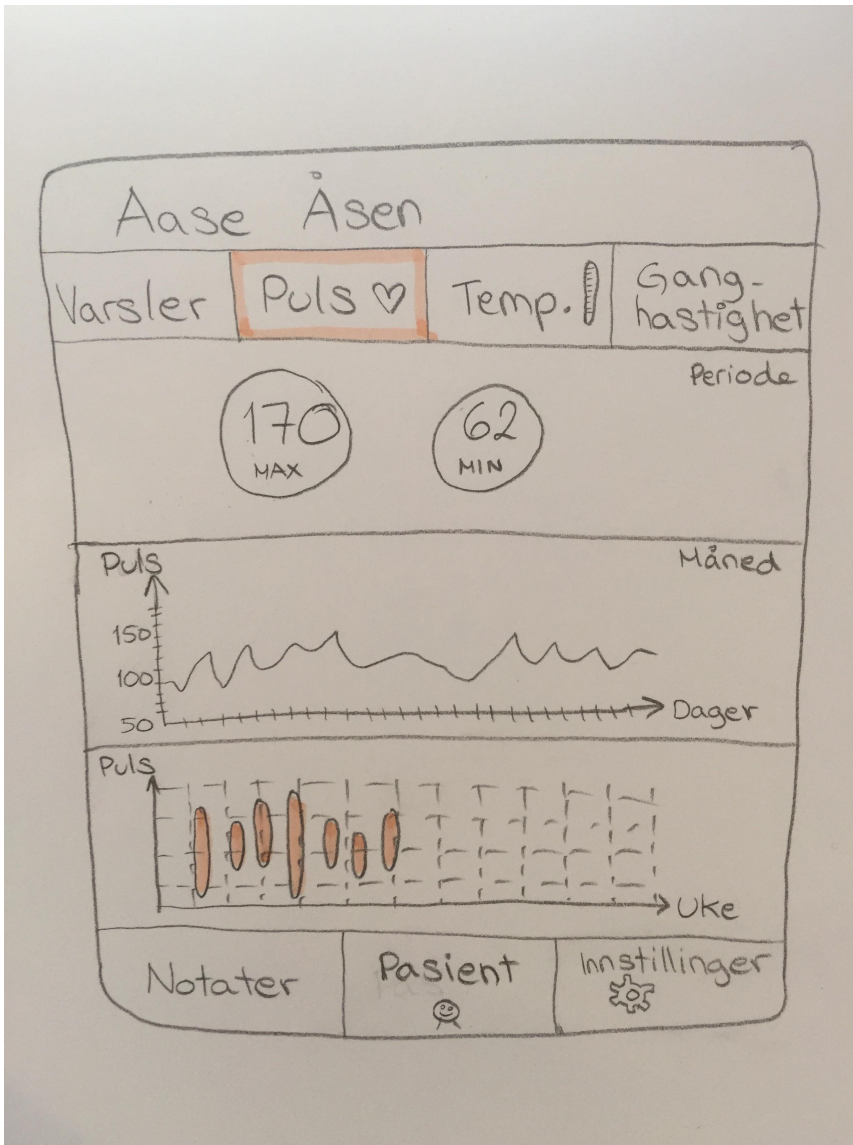

**Figure 13.5:** Information page, Pulse

Figure 13.6 is a clear and simple page with the name of the product and orange background colour to attract attention[102]. The orange colour represents excitement, warmth and vitality and is often used in technology and health [103]. Because the sensors in Safestep record sensitive health information about the user, the security around the data is important. A security measure will be that the person using the app has to log in with a user name and password as seen in Figure 13.7. The first textbox at the top of the page is to write username inside and the next textbox is for the password. The first time for a



**Figure 13.6:** Frontpage

new user the textbox should be filled out and the button to the right, "registrer" should be pressed to make a new account. People who are already registered, just presses the button "logg inn" to the left, to log in to their account.

The sensors used in Safestep will record information that can be very sensitive, a safety measure will be that the person using the app has to log in with a user name and a password as seen in Figure 13.7.

Health professionals could have several patients that use Safestep, so it is important to know whose data they are viewing. The health professional can access the different users of Safestep via a menu, much like a contact list on a phone. This menu will not be needed for the next of kin if they only have one family member using Safestep. It is from this menu that a new person can be added to the list, here relevant information, e.g age, weight or gender, can be added.

After choosing the individual it will be possible to choose what data one wishes to view. This will be displayed on the top of the screen, below the name of the person the data is from. When choosing what to view, the data will be displayed in different ways. It will show a graph displaying the values over different time periods, the period can be chosen by the person who uses the app. There will be a section displaying the most important values for the category, e.g maximum and minimum pulse. Columns can display all the

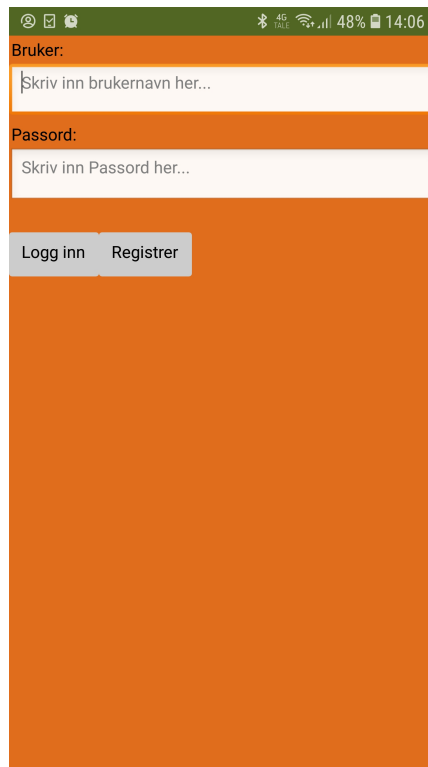

**Figure 13.7:** Login

values recorded over a period of time, the pulse recorded one week will be one column and the pulse recorded the week after can be the second column. These columns can be compared to see if there are changes over time.

A pop-up warning should appear if attention is needed. If the user's body temperature indicates fever or a sudden change in pulse, this can indicate that the user is getting sick. This is not an emergency like a fall might be, but it is still important to know. The health professional might only visit the person a few times per week, but illness could require more frequent and more immediate attention. Such a warning should be able to read immediately after logging in, so there will be a menu where the user can click on the warning and access that person's file directly.

Figure 13.4 and figure 13.5 shows the different windows that will be displayed during use. Here the menu with the list of patients/users are shown, the window with the different warnings is shown and the window for an individual's data is shown. By following the arrows on the drawing the order of the windows when using the app is also illustrated.

The frequency of data transfer from Safestep and the app will vary. How frequent this will happen needs to be based on the severity of what has been recorded. If Safestep detects an onset illness or a fall, then someone should be informed quickly. If Safestep is recording data consistent with normal behavior, then this will simply be added to the statistics and





**Figure 13.8:** Temperature, Pulse and Walking speed

does not need an immediate transfer. To decide the frequency from a medical view, other professionals will have to research as we are not qualified to make a decision based on medical reasoning.

The data recorded by Safestep will also be organized in such a way that useful information can be forwarded to a person's physician so that he/she can evaluate the data and get a better impression of a person's health situation. This will be a function included in the app, and will not be done unless actively chosen so that the physician is not receiving information that is not requested or needed.

In Figure 13.9 it is shown an example of design for an App. This is the App made for relatives and health professionals like home nurses.



(a) Frontpage



(b) Notes



(c) Notifications

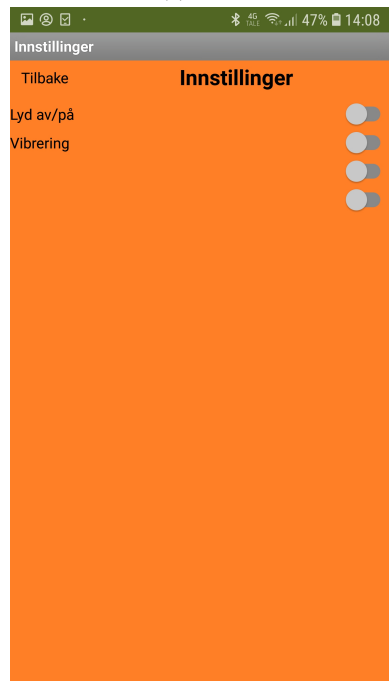

(d) Settings

**Figure 13.9:** Example of App design

## 13.2 Programming language

To make the App, the MIT app inventor program is being used. The programming is done by using predetermined boxes with different characteristics. Combining different boxes gives different possibilities like in normal programming.

### 13.3 Code

The code is written as an example of programming that could be used for an app with imagined relevant functions. This includes as mentioned earlier, log in to make the data more secure, different pages with health information from the user, any alerts, an own page to take notes and a page with settings. How the programming is done for the different settings on the different pages will not be discussed in detail, but the presenting of data will be mentioned and the log in system will be further explained.

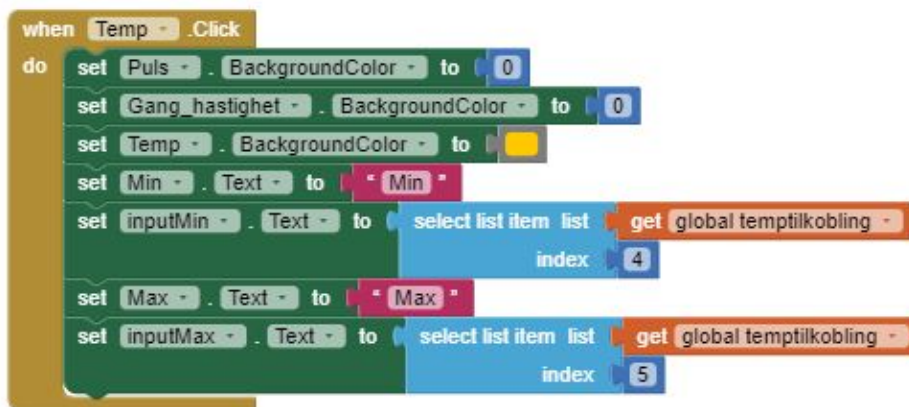

Figure 13.10: Show temperature information in the app

Which category of health data showing in the app is as mentioned earlier decided by the user of the app by touching the wanted category. This is easily done by hiding the information not wanted to be viewed, at the same time as the elements with the wanted information become visible. The headings in the menu are the same as seen in Figure 13.8, but the information illustrated with the earths will change. In the programming shown in Figure 13.10 the heading temperature will be highlighted with yellow after it is clicked. This will show the user which information page they are viewing. Unvisible textboxes will be changed to the text written in the code "Max" and "Min" and the temperatures will be set to the forth and fifth element in the string with information received from Safestep. The string with information will contain all the elements wanted from the Safestep, pulse, max. and min. temperature and walking speed in this order. When the app wants to view the data, it retrieves the right values by choosing the right element. In this way, the app will view the wanted data when the user clicks on a category. A click on temperature will close the headings from pulse and walking speed by setting them to false. All these pages

are programmed similar to the same menu showing on all the pages, but with different health information shown.

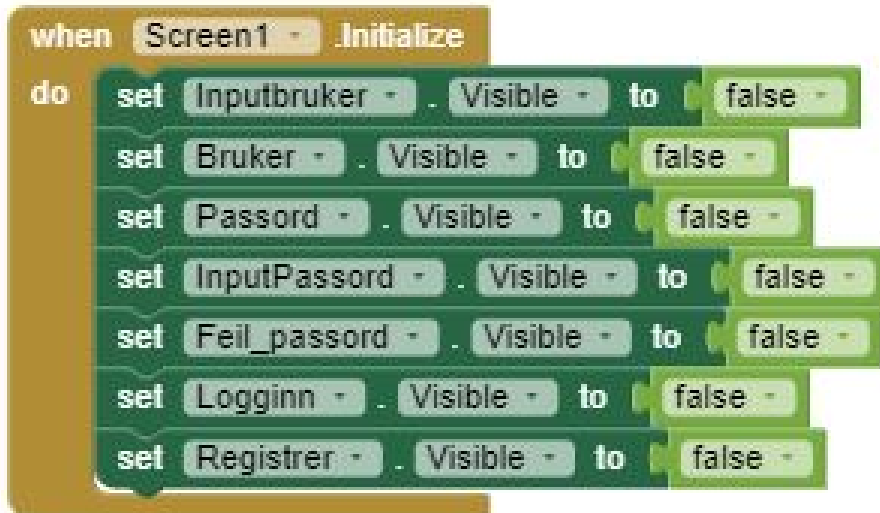
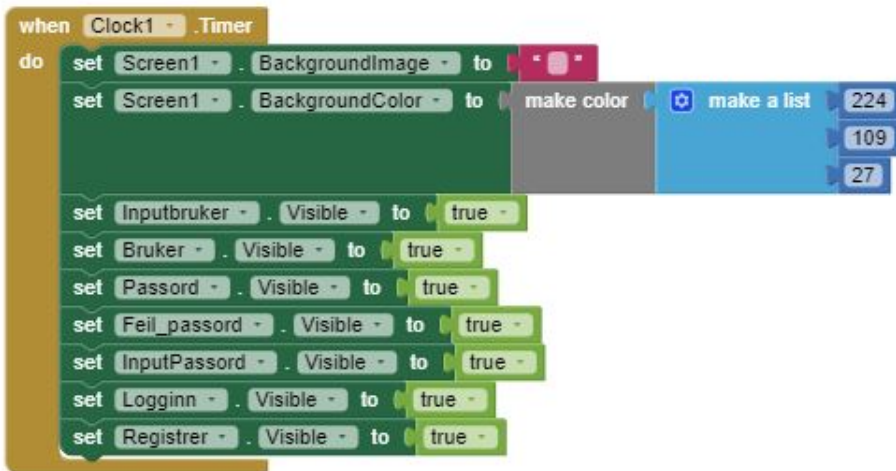

Figure 13.11: When the app is opened

When the app initializes, the front page as written about earlier and seen in Figure 13.6 will show. Programmed on Figure 13.11, all the headlines and other information to be visible after the front page are set to false. This will make it possible for only the background picture in the front page to be visible. After a set timer, the visible components in the app will change as Figure 13.12 shows. Here the background picture will be set to zero, be deleted, and then the background colour will be set to the colour (224,109,27) which is the orange colour seen in the Figure 13.7. All wanted text, buttons and other components on the page will be visible after set to true.



**Figure 13.12:** After a set time

Figure 13.12 set all the elements needed for the login page visible and for the user of the app it will look like the app switched to another page. The page now seen is illustrated above in Figure 13.7.

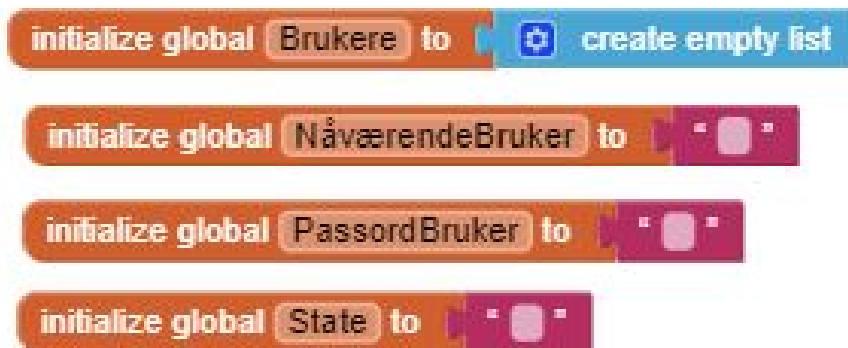

**Figure 13.13:** Creating global variables

How the login is programmed are shown in Figure 13.13 and Figure 13.14 to Figure 13.17. There is created an empty list that later will be used to save all the new registered users and there are created some global variables now set to "" in Figure 13.13.

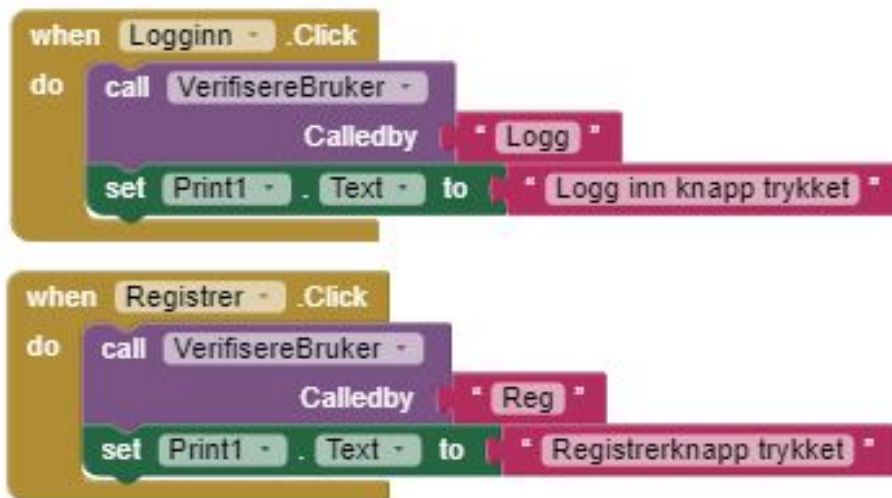

**Figure 13.14:** When the login or register button is clicked

When a user writes their username and password in the text boxes and clicks the "login" or the "register" button, the app will go to the programming in Figure 13.14. If the button "log in" is clicked the function in purple beneath "When logginn.click" is the next step. This function will check if the user trying to log in is a previous user. The function shown in Figure 13.15 will first check if the user has written both a username and a password in the visible textboxes. If both textboxes are written, the username will be checked to the existing list with all the usernames registered. This is done with the function in Figure 13.18. If the username can be found there, then the password is checked if it is the equivalent password to this username in Figure 13.16. If both the username and password are correct, the user will be sent to the next page already seen in Figure 13.8 with the procedure seen in Figure 13.17. If something is not right a message telling the username or password is wrong will show up.

If the user of the app clicks on the button "register" after plotting username and password, the same check of empty textboxes will be done. If both fields contain text, the username will be compared to the list with all users. The Function in Figure 13.18 compare and make a new user if the username is not used before.

```

to VerifisereBruker Calledby
do
  if not is empty Inputbruker . Text and not is empty InputPassord . Text
  then
    set global State to get Calledb
    set global NåværendeBruker to lowercase Inputbruker . Text
    set global PassordBruker to InputPassord . Text
    call FirebaseDB1 . GefTagList
  else
    call Notifier1 . ShowMessageDialog
      message "Ugyldig brukernavn eller passord "
      title "Logg inn error "
      buttonText "OK "
  end
end

```

Figure 13.15: Procedure verify the user

```

when FirebaseDB1 . GotValue
  tag value
do
  if get tag = "password "
  then
    if get value = get global PassordBruker
    then
      call AktiverBruker
    else
      call Notifier1 . ShowMessageDialog
        message "Ugyldig brukernavn eller passord "
        title "Logg inn error "
        buttonText "OK "
    end
  end
end

```

Figure 13.16: Function, when Firebase got value

```

to AktiverBruker
do
  set global State to "Aktiv "
  open another screen screenName "Bruker "
end

```

Figure 13.17: Procedure, activate the user

```

when FirebaseDB1 - .TagList
  value
do
  set global Brukere - to get value -
  call Notifier1 - .ShowMessageDialog
    message get global Brukere -
    title "Alle brukere"
    buttonText "Ok"
  if is in list? thing
    list
    then
      if
        get global State - = - "Reg"
      then
        call Notifier1 - .ShowMessageDialog
          message get global NåværendeBruker -
          title "Brukernavn eksisterer allerede"
          buttonText "OK"
      else if
        get global State - = - "Logg"
      then
        set FirebaseDB1 - . ProjectBucket - to get global NåværendeBruker -
        call FirebaseDB1 - .GetValue
          tag "passord"
          valueIfTagNotThere ""
      else
        set FirebaseDB1 - . ProjectBucket - to get global NåværendeBruker -
        call FirebaseDB1 - .StoreValue
          tag "passord"
          valueToStore get global PassordBruker -
        call AktiverBruker -
    end
  end
end

```

Figure 13.18: Function, when Firebase tag list



# Chapter 14

## Possible functionalities to implement and tests that can be performed

Safestep is meant to have many functionalities. These will all need to be developed and tested to ensure quality, safety and usefulness. From the author's views the most important ones are the following:

- How to identify the added value of each sensor
- How someone's activity level can be measured
- How erroneous statistics can be detected and discarded
- Can detection of a person falling be performed better with more sensors or could that result in some falls going undetected due to too strict requirements?
- How to test the combination of the individual systems and functionalities

Most of these were not possible to test and implement due to the corona outbreak. Instead, they are described in detail here. Besides, other potential functionalities are also included but considered to be less crucial.

Figure 14.1 shows the combined parts of what the candidates had been working on before the corona outbreak. The proposed design combined with what Safestep monitors and that information is sent to the app.

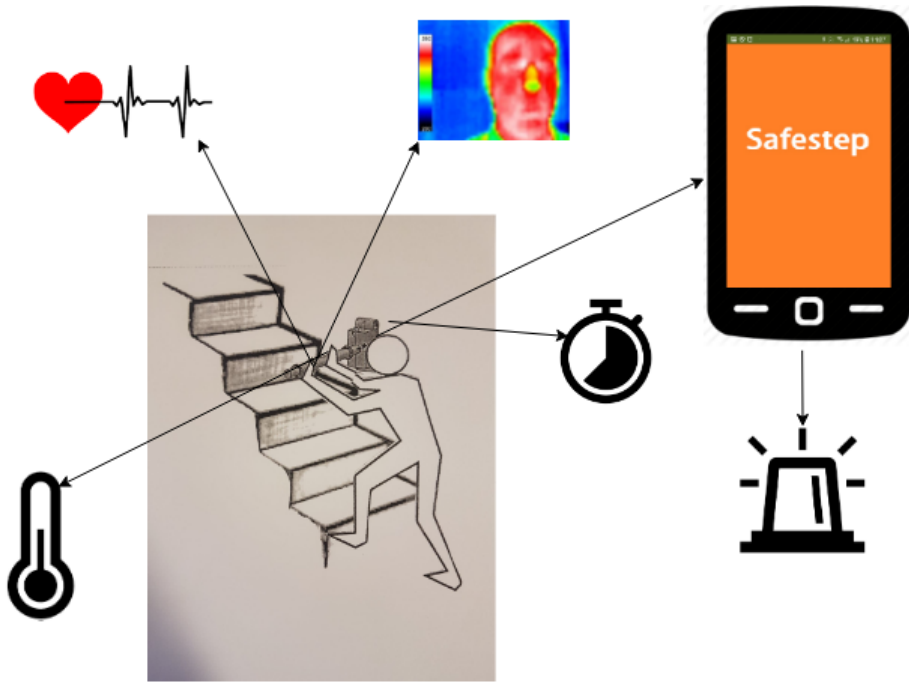

**Figure 14.1:** Safestep with what it monitors and the Safestep app

## 14.1 How to monitor activity level

Why monitoring activity level could be of interest is because people are likely to have a certain pattern in their daily lives. A child could run up and down the stairs when playing, parents with an infant might run up and down to the child's bedroom every time it cries and teenagers could stay in their room all day and only come down to eat. These are not accurate descriptions, but illustrations of how many times someone uses the stairs could reflect their life situation. This is also possible for the elderly.

With challenges that come with old age, stairs can be a bigger obstacle than previously in life, but it is still necessary to use if one lives in a multistory home. If an independent elderly person has their bathroom and bedroom on the first floor, kitchen and living room on the ground floor, then there will be many times when they need to move between floors. It is the routines regarding this sort of daily activity that can be detected by measuring how many times Safestep is used. If there is a sudden and substantial drop in a number of times, then it could be because negotiating stairs has suddenly become too great of an effort. Maybe the person has back problems, maybe they have pneumonia, maybe they do not have to use the bathroom so often because of constipation or maybe it is nothing of significance at all. There are a lot of reasons the activity level might change, but a sudden change in a routine lifestyle is quite possibly a sign of some underlying issue.

The way Safestep will monitor this is:

1. Register the number of times a person uses the stairs.
2. Repeat this over a period of time to get an image of what is a normal activity level
3. Compare daily activity with the normal level.

This is illustrated and elaborated further in figure 14.2. Here it is also shown that abnormal activity should be registered over a period of days so that no alert is sent out simply because of the first sign of reduced activity.

If there is a significant change, then Safestep will take note of this. If the change is prolonged (e.g for days) then this can be an indication that something is wrong and health care workers or next of kin could be alerted so that the elderly individual can be checked upon.

Possible causes for false/non-representative data:

- Gone on holiday
- Comparing activity on e.g a Saturday with a Wednesday

The activity level in one's home can be substantially different one day of the week compared to the next. People have jobs, hobbies, responsibilities that can cause them to leave their homes for a period of time. That is why the activity level should be used so that Mondays are compared with other Mondays and Saturday with other Saturdays.

The suggested set up for this test and how it should be performed is:

- Install a sensor in the staircase of an elderly people's home, someone who lives alone so that other people do not affect the results too much. On Safestep, many of the sensors could be used to check activity, but for this test, some form of proximity sensor could be installed in the middle of the staircase. From chapter 9, capacitive, photoelectric or ultrasonic could work.
- Make recordings of the activity level in the staircase over a long period of time. How long might be decided based on the results, the assumption is that it needs to detect a pattern of what is a normal activity.
- After the period is over. Interview/talk to the individual regarding days where the activity level is different from what is normal. See if that was due to something being wrong and if it would have been beneficial that someone had been alerted.

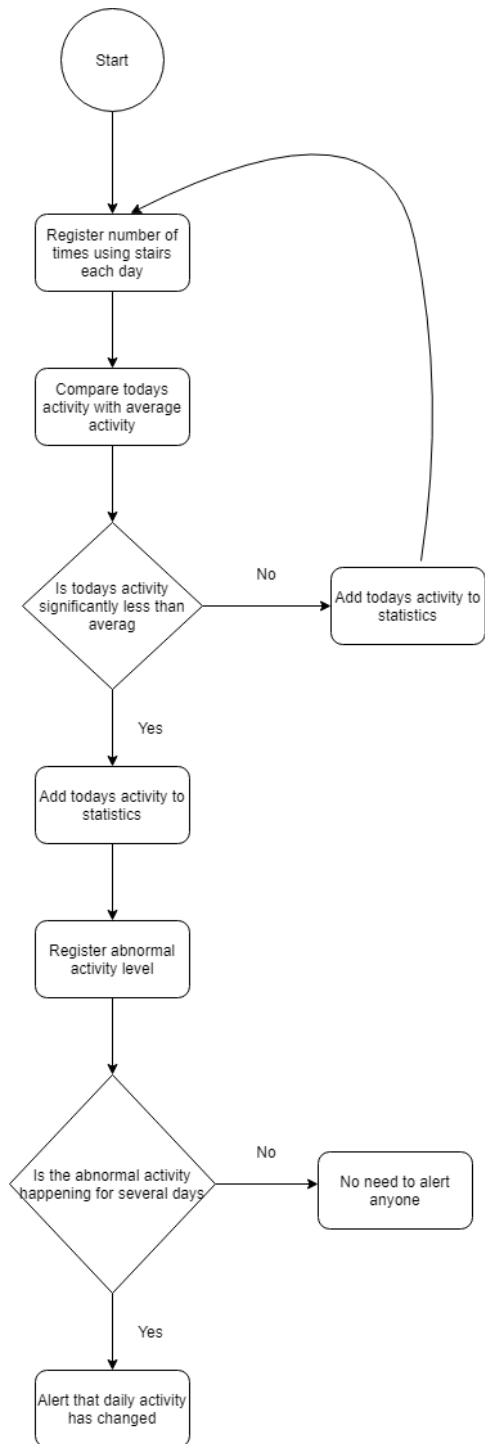

**Figure 14.2:** Diagram illustrating how the activity could be monitored

## 14.2 Erroneous statistics

Erroneous data could be added to the statistics if not handled. This can result in a false image of what will be considered as normal values. This goes for body temperature, stair negotiation time, heart rate and activity level. Since these can be used to indicate how the health situation of a person is, it is important to not have readings that will give a false image of what normal values are. Both false alarms when someone is fine and the absence of alarms when someone needs help could occur due to poor data. Temperature, stair negotiation time, heart rate and activity level will each have to be handled separately in some way, but a common description is presented here of how erroneous data could be detected, and how Safestep could act.

An easy way of handling erroneous data is comparing to possible values. Table 14.1 shows values that are within a large range, that can be used to detect outliers. The time it takes to negotiate stairs was estimated by the authors walking up a 16 steps staircase with their normal gait and by simulating what was believed to be a gait speed of someone with impaired mobility.

What is monitored	Possible values
Temperature	35.3-37.7°C [104]
Heart rate	50-110 Bpm [105]
Stair negotiation time	11-48 seconds
Number of times using the stairs	Depends on the individual

**Table 14.1:** Temperature values that 99% of the population falls within, heart rate range covering resting heart rate and rate under some strain, time is based on an estimate done by the authors on how long it can take to walk a 16 steps staircase.

As time passes, Safestep will gather more and more data which will give an increasingly accurate image of what the individual's normal values are. Then this can function as normal values for that individual. If that person shows signs of something being wrong, their normal values together with the possible values from table 14.1 will be used to see if it is a sign of poor health or if it is a reading that should be discarded because the value is too unlikely to be true. Figure 14.3 shows how the process of comparing values to possible values could work.

This process must not affect abnormal data. A heart rate of 300 bpm is safe to discard due to its impossible high value. A heart rate of 130 however, is outside the normal range, but possible, and could be important to be aware of.

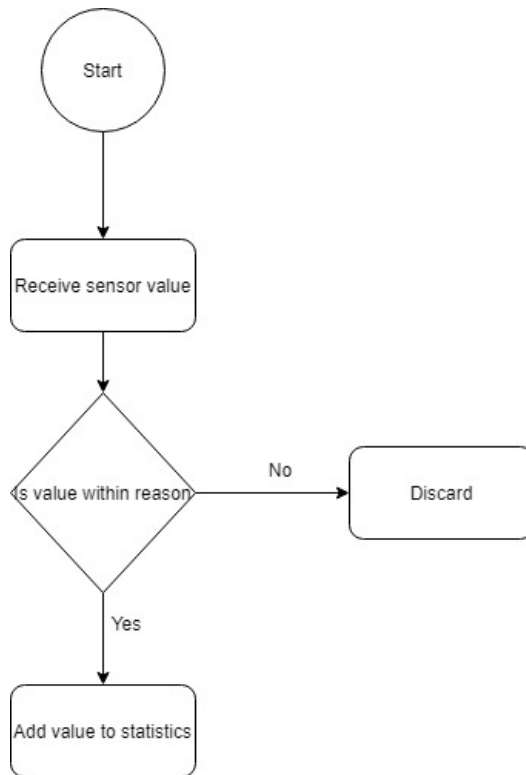

**Figure 14.3:** Diagram for checking sensor values

## 14.3 Test each individual sensor to collect data as best as possible

### 14.3.1 Heart rate monitor

Figure 14.4 shows a flow chart describing how getting the heart rate by using ECG values could be done. The QRS complex was described in chapter 11, and this complex appears once for every heartbeat. By detecting the highest values received from the AD8232, the time between them can be used to return the heart rate. This would require some preparations:

- the sampling frequency must be identified, to ensure that one actually samples at the time when the peak of the QRS complex happens.
- What values are linked with the peak of the QRS complex must be identified.

A heart rate should not be given based on merely the time between two beats, but as an average over the time that measuring happens.

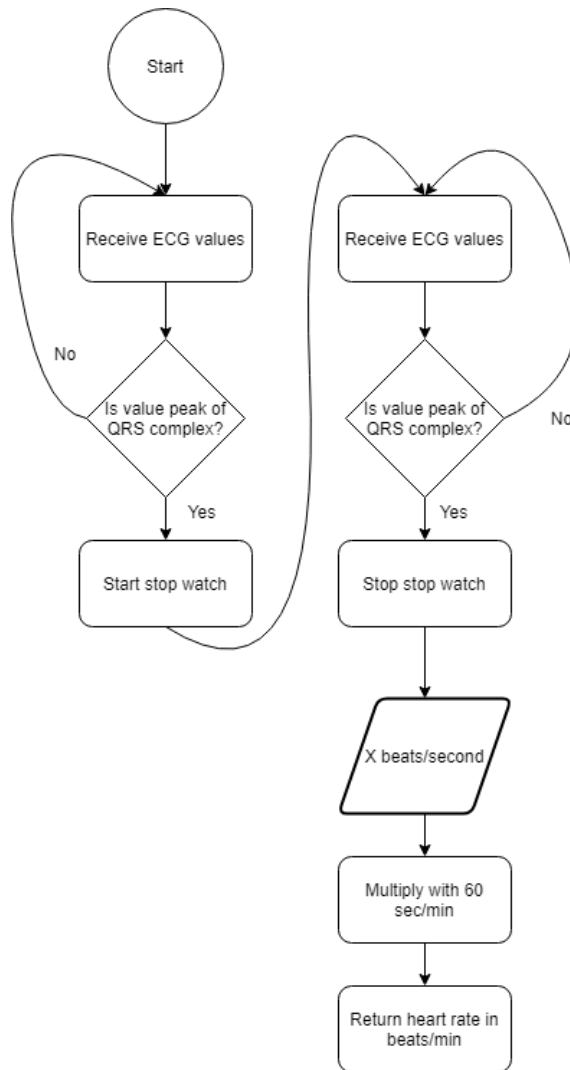

**Figure 14.4:** How to collect heart rate from an ECG

Also important with the Single lead heart rate monitor-AD8232, is if contact with the electrodes will be sufficient while walking so that the sensor detects adequate data that can result in returning a person's heart rate.

The proposed test is simple. An individual should have a pulse belt attached to him to read the heart rate. Then electrodes will be attached to a cylinder. The person performing the test will then adjust his grip in different ways. By mimicking how one might shift one's grip when using Safestep, it could detect if it is possible to detect the heart rate. The values detected should then be compared with the ones from the pulse belt to see if they are correct.

This test could reveal if Safestep can detect heart rate. Other findings could for example be different placement of the electrodes or modifications of the design so that reading heart rate is possible.

Figure 14.5 shows some examples of how someone's grip might change during the use of Safestep.

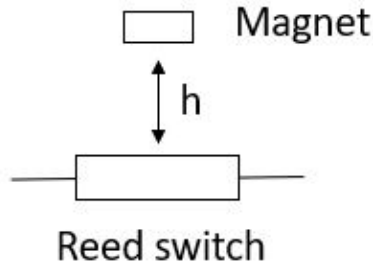

**Figure 14.5:** Possible ways someone might hold on to Safestep

### 14.3.2 Test of Reed switch

When testing it is important to use a situation as similar as possible to the real situation. The reed switch will be used to take the time and to register possible falls. For the reed switch to register the proximity of a magnet, the distance between them needs to be small enough. This distance can be tested by gradually moving the magnet closer to the switch and measure the distance when the wires in the reed switch get in contact, as illustrated in Figure 14.6. Doing this around at least 10 times will give the longest distance the magnet can have to the reed switch. Now knowing the distance the switch for sure will register it is smart to also test if the speed of the magnet can influence the registration. Testing to move the magnet at different speeds past the switch to see if it has an impact on the switch as in Figure 14.7. If this is not the case, it is nothing to think about in further testing. If the switch for example at higher speeds of the magnet is not able to register the proximity of the magnet, the speed needs to be compared to the speed of Safestep later. If Safestep's speed anyhow is below the maximum speed for the switch to register it will not be necessary to think about. Is it the opposite, a bigger magnet have to be tested.





**Figure 14.6:** Testing reaction height for magnet

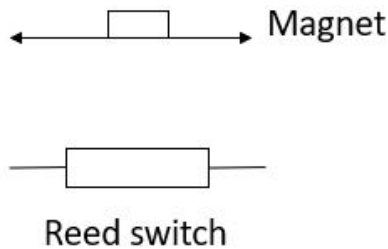

**Figure 14.7:** Testing speed

After knowing the reed switch and the magnet work together and under what conditions, this is ready to be tested in the stairs. Install the reed switch at the end of Safestep pointing towards the banister. Move Safestep’s handle all the way up the stairs and down again some times to see if the register of time is right. Then test if Safestep discovers a possible fall if you stop in the middle of the stairs and release the handle. If this works after testing multiple times, the fall registration is working which is the most important function of the reed switch. If it is not working it can be smart to look at other factors as the pressure sensors also involved in the fall registration.

### 14.3.3 LM35 and thermal camera-AMG8833

Both the LM35 and the AMG8833 thermal camera are intended to measure body temperature. The LM35 needs contact with the skin, the AMG8833 measures from a distance. Of most interest is if they are able to detect body temperature and that the results are good enough to detect if a change happens over time. There is a strong possibility that various things could affect the temperature of a person’s skin. This would in turn affect the LM35 and thermal camera reports of the body temperature.

Examples of what could affect readings:

- What the person has recently done, e.g holding a hot cup of coffee, been outside, taken a shower
- Is there someone behind him in the stairs in the viewing field of the thermal camera
- Fluctuating surrounding temperature

What is to be discovered is if these components can detect a change in someone's body temperature over time. If not, then the same procedure could possibly be used to try out other temperature sensors that might work better.

The LM35 will be the one most affected by the activities a person has done. The hands are in contact with many different objects during the day, and many of these can affect what temperature the hands have. The thermal camera is not as affected.

If the sensors are able to detect that the person is affected by what he has recently done, then this could be used as a condition that decides if the temperature readings are an actual reading of body temperature or if it should be disregarded. Seeing that there could be individual differences in what is a normal body temperature (seen in 14.2). Therefore it would be important to have a way of detecting when the temperature is influenced by recent activity so that it is not treated as the actual temperature. Because this could lead to troubles in detecting actual abnormal body temperature. This could possibly lead to unnecessary concern among the ones that receive the reported data through the Safestep app.

One way of detecting that someone's temperature is affected by recent activity starts with the assumption that the temperature will change during stair negotiation, but not if temperature is unaffected by recent activity.

If the temperature is affected by what one has recently done, this effect might start to wear off during the ascend or descend. The temperature readings can, therefore, be compared with each other during the walk. If they change during, then this could be an indication that the abnormal temperature is due to recent activity and not actual body temperature. The readings could then be discarded.

Figure 14.8 shows a flowchart of how this could be done. If the results from the LM35 or the thermal camera is sufficiently close to what was previously read, then a variable (here *counter*) could be incremented. When finished walking, this variable would have to be big enough to accept the results as true body temperature.

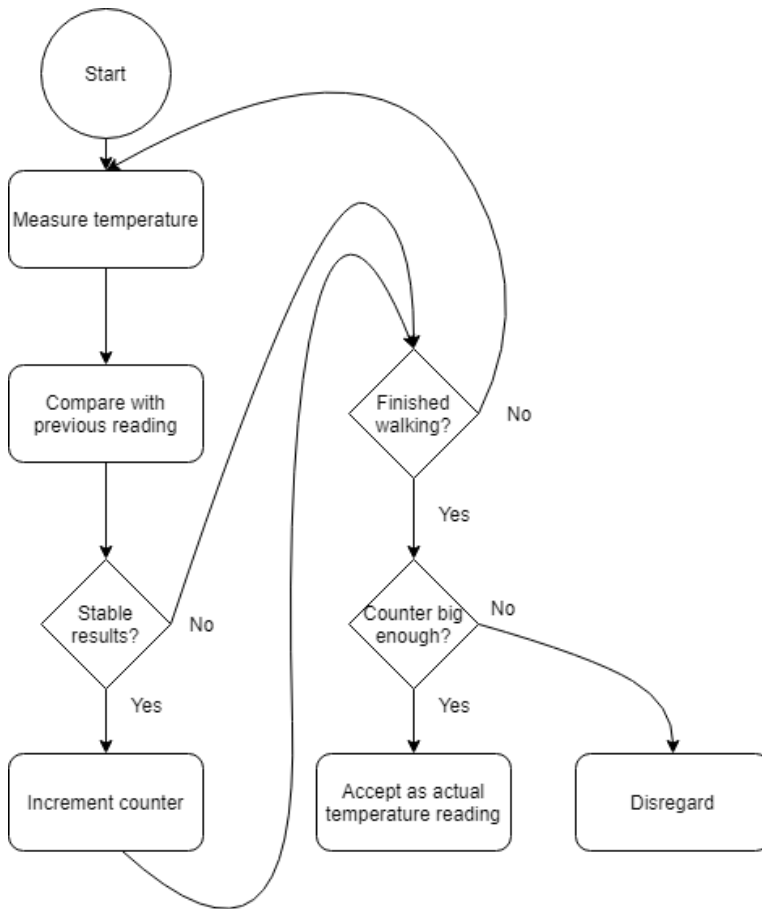

**Figure 14.8:** How to identify correct temperature readings

There is possibly a big challenge with this, and the use of the LM35. When this sensor makes contact with the skin, the temperature will rise when skin temperature is higher than room temperature. Because what the LM35 senses before being touched is the room temperature. This would go against the initial assumption. A possible way of handling this could be to detect what is a normal change, and that this might have a certain behavior that can be detected. This might not be as challenging with the thermal camera, because the parts of its viewing field that is not the person, could be disregarded based on its difference with the viewing field containing the face of the individual. It is likely possible to detect what is surroundings and what is a person when using the thermal camera.

Also, like what is described in 14.3.1, how the grip might change during stair negotiation would affect how well the LM35 would perform. To test this, the same procedure as described for the AD8232 in 14.3.1, can be done with the LM35. The most important difference would be that the electrodes attached to the AD8232 require in total 3 points of contact. The LM35 only requires 1.

#### 14.3.4 Test of FSR

A force sensitive resistor registers a change in resistance if it is pushed. In Safestep this is used to control the motor assistance when pushing the handle upwards and to register if the user is holding the handle or not. Controlling the motor assistance will be done with the varying amount of pressure on the FSR. To do this, testing which pressure value the resistor normally will register when the handle is held, has to be done. It is also necessary to find the limit value for when the increase in pressure can tell assistance with a motor is wanted. Testing this can be done by repeatedly measuring the pressure with different grip on the handle and let different persons try it. Then let the test persons start walking by pressing the handle in front of them to measure the difference. The system for using the amount of pressure to regulate the motor power is comprehensive and needs to be worked on with iterations. Small adjustments before testing and then back to adjusting.

More important is the registration and alerts if someone falls in the stairs. This is an alert if FSR registers that the user has let go of the handle in the middle of the stairs. For this to be trusted to work every time it should be tested multiple times.

By identifying what range of forces would indicate that the user is trying to push Safestep forward, and which side of Safestep is experiencing pressure, it is possible to distinguish the motions and only activate the DC motor when needed. The FSR is not a very precise sensor, but it is possible to use when detecting a range of responses, which will be the case for Safestep since the force applied by the individual user will vary. In [99], an advice is given on how to obtain the best force repeatability. This is to use a thin elastomer between the force applied and the FSR. When using Safestep, people can apply pressure unevenly. By having an elastomer (e.g a rubber handle), the pressure that the FSR experiences are likely more evenly distributed and responds appropriately. But this must also be implemented so that pressure applied without the intent of moving (e.g leaning to rest) does not activate the motor. With the use of a rubber handle that goes all the way round, the pressure applied to an area where the FSR is not, can still affect the FSR. A possible solution could be to have a thinner wall following the perimeter of the FSR. That way the pressure might not disperse to the FSR. An illustration showing how the rubber handle can be made with a lowering in the material around the perimeter of the FSR is shown in figure 14.9

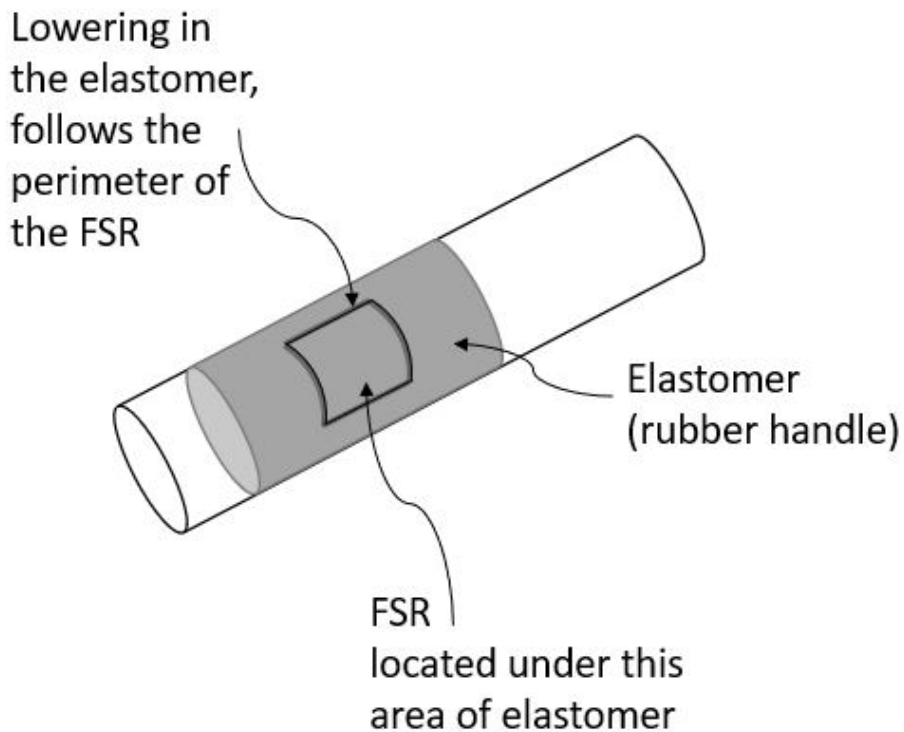
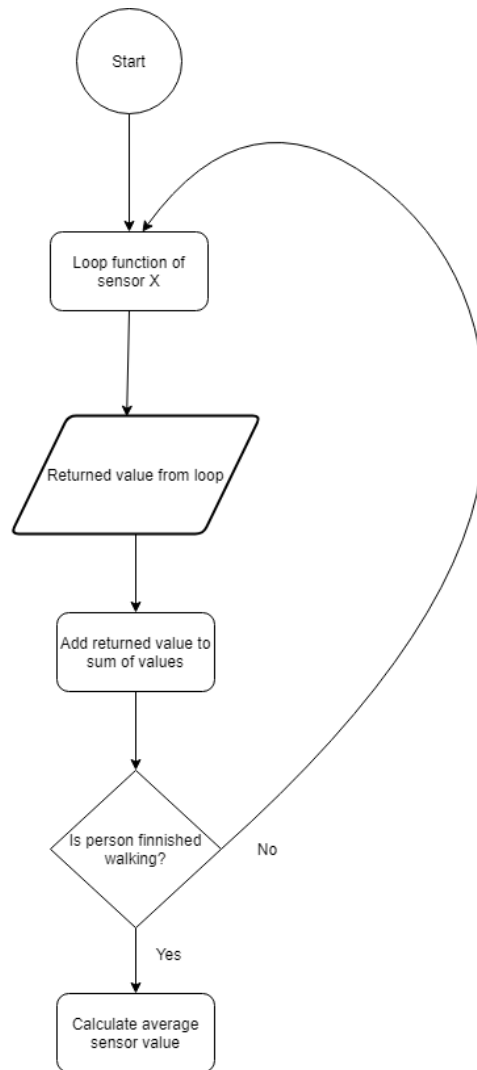

**Figure 14.9:** Illustration showing the lowering of the rubber handle around the area where the FSR is located

## 14.4 Average values

The sensors used can read many different values as a person walks in the stairs. The temperature sensor could fluctuate, so can the heart rate monitor. The heart rate monitor is even likely to report a pulse of 0 at times, due to loss of contact between electrodes and hands. With this in mind, the average values could prove more of use. Another option could be to use the maximum value, but only the average value approach is described here.

Figure 14.10 shows the general flow chart for calculating average sensor values. The sensor reads continuously as a person uses Safestep. These can be added up, and when finished walking, the average can be found.

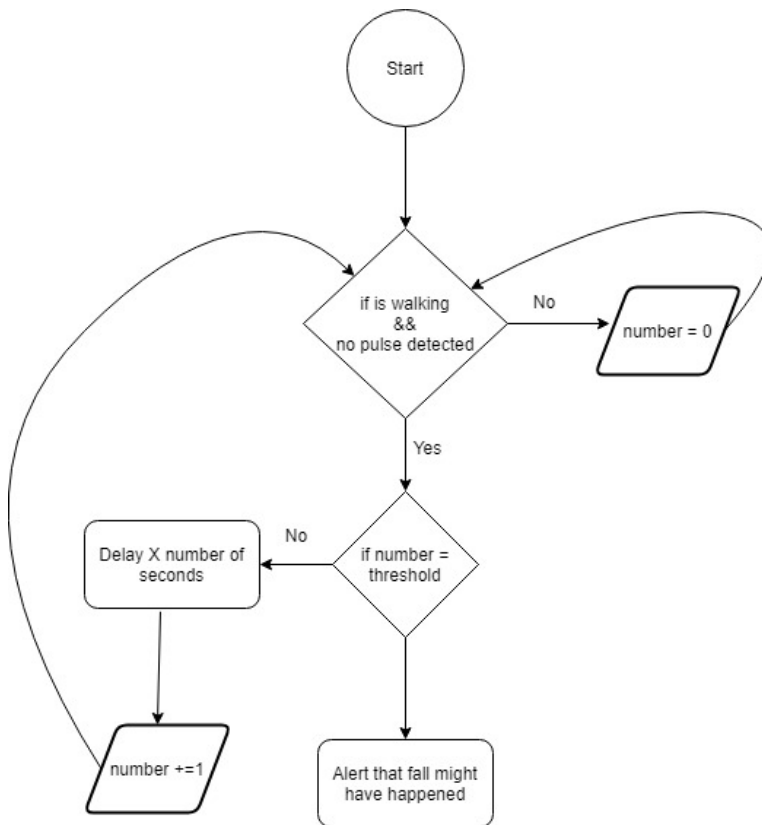

**Figure 14.10:** Flowchart for calculating average sensor values

## 14.5 Include more sensors in detecting falls

The way Safestep could detect falls is described in chapter 12.3. It is possible that this way might not detect every occurrence of falls. Using the FSR and timing functionality seemed to work well when being developed, but it is possible that it might fail in some situations. If someone falls, first onto Safestep and then down the stairs, maybe the impact with Safestep damages the FSR, with a possible result being that no one is alerted that a fall has happened. When consequences can be severe, the risk of not detecting the event should be as little as possible.

The temperature and heart rate sensors rely on interaction with the individual using Safestep. This means that if the person has fallen, contact with these sensors will get lost, which can then be used to alert that a fall has happened.

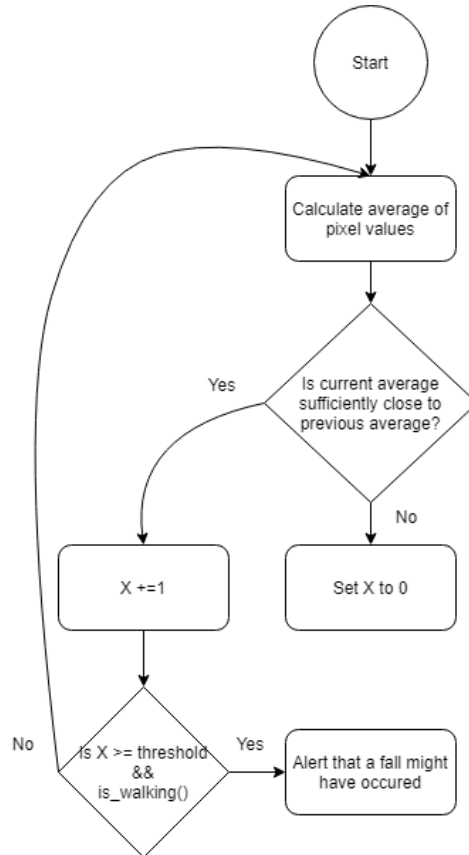

**Figure 14.11:** Flowchart showing how falling can be detected using the heart rate sensor

A system that includes a heart rate sensor is described in figure 14.11, and it could work quite similar to what is shown in figure 12.6, but because a shifting grip could lead to loss of contact at times, it is probably smart to check that the heart rate has not been detected over a sufficient enough long time. That is why a variable should be incremented when no heart rate is detected. If the heart rate is detected, this variable is set to 0, if not it will increment up to a threshold value. If the threshold value is reached, someone will be alerted that a fall might have occurred. What the threshold value should be would depend on how well the heart rate sensor performs during testing in a more complete prototype, and the same goes for how long the delay should be. This also uses the reed switch to check that someone has started walking, using the *is\_walking()* function described in figure 12.4.

The temperature sensors could also be utilized in detecting falls. The thermal camera is chosen as an example for this additional purpose. All 64 pixels of the thermal camera has its own temperature reading, and these respond

quickly to changes. From a simple test of moving a person closer and then further away from the camera, the reported pixel values changed quickly. This can be used to check the average value of all 64 pixels, as this will change when a person moves in the line of sight of the camera during stair negotiation. If the average value stays the same, or does not alter sufficiently, and the *is\_walking()* indicates that someone is in the stairs. Then this can indicate that the person has fallen. A potential source of wrong results could be that the user is leaning towards the wall to look at something, so the average value should be checked over a certain amount of time.



**Figure 14.12:** Flowchart showing how falling can be detected using the thermal camera and checking if someone is walking

Figure 14.12 shows the flowchart explaining how this could be done. Once again, a false alarm could be avoided by ensuring that the average value has not changed over a sufficiently long time. This way of checking if a fall has happened includes the use of the *is\_walking()* function. *is\_walking()* is considered by the candidates, to be the most reliable part of the system that can detect that someone is using Safestep.



## 14.6 Test of the complete system

After implementing and testing what is so far described in this chapter, it would be necessary to try it out together. This could reveal possible conflicts between the different systems. This also goes for what is described in chapter 12. This has been implemented, but not yet tested with an actual prototype of a handle mounted in a staircase that can support someone when walking.

The test could be divided into two, one to test the sensors and one to test the motor.

### 14.6.1 Sensors

To test the sensors the set up would require a handle attached to a banister that can move up and down, but it does not need the motor. The purpose of this is to see if the sensors work together, and identify possible conflicts between them.

Figure 14.13 shows a possible way of placing the FSRs and the LM35.

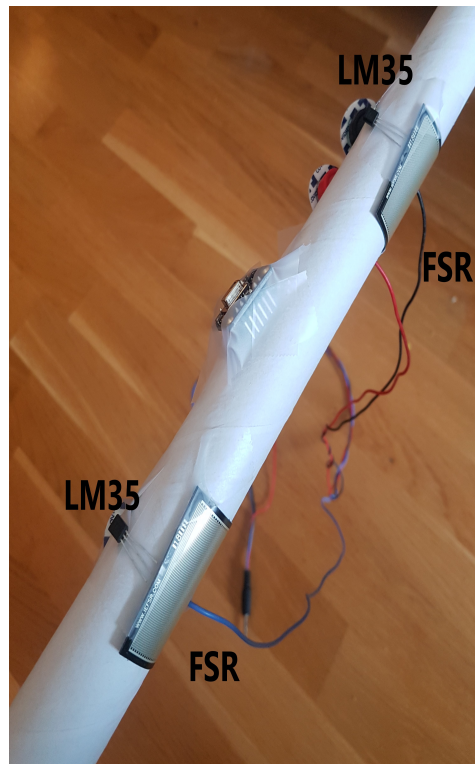

**Figure 14.13:** Picture of where the different sensors could be placed

Figure 14.14 shows a possible way of placing the thermal camera and the electrodes of the heart rate sensor. Both figure 14.14 and 14.13 are based on possible placement,

described in chapter 7, and is done by taping the components onto a cardboard tube, to give a clearer description of how a prototype with sensors could look. Attaching the sensors to the cardboard tube was the best visualization the candidates could manage, without access to equipment and material from the school. But it still serves a useful purpose, as it should provide a clearer picture of how a prototype could look, and therefore how Safestep could look

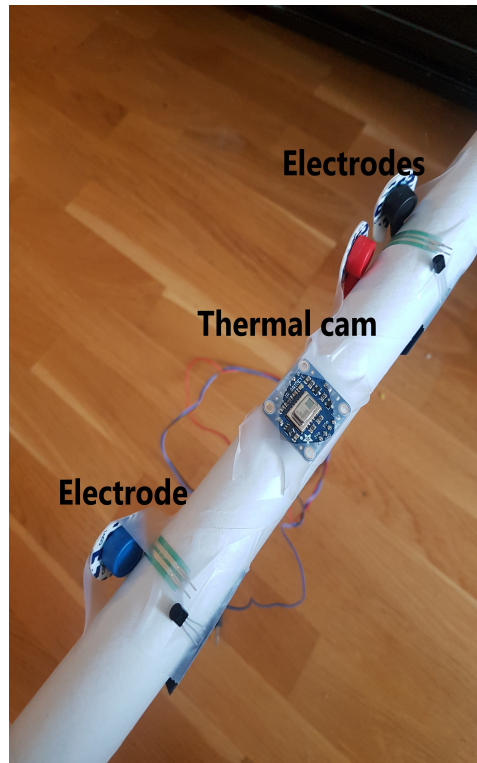

**Figure 14.14:** Picture of where the different sensors could be placed

### 14.6.2 Motor

To test if the motor responds to the readings from the FSR, the candidate proposes a simple setup. Using a rack and pinion, described in 7.3.3, placed on a flat surface. The rack is fixed to the surface, and the pinion is connected to the DC motor which in turn is attached to a handle. The handle has two FSRs that detects force. The purpose is to see how the proposed system with a rack and pinion, FSR and DC motor responds. It can reveal if the response time is too slow, how comfortable it is, for example, if there are sudden jerks or if it slows down too slow.

The value that a DC motor could add, is uncertain. By testing it in the way described here, some of the challenges and possibilities could be detected.

## 14.7 Communication

When an elevator breaks down, contact with anyone who might be inside, is important. Therefore, elevators should have a way of communicating with anyone inside. In the same way, Safestep could benefit from a communication system. Figure 14.15 shows a flowchart describing how such a system could work.

1. Safestep detects signs that a fall has occurred
2. Contact is attempted established
3. The situation could be assessed through communication
4. Proper help could be dispatched

By performing what is described above and in figure 14.15, false alarms could be clarified. The appropriate kind of help could be dispatched, and comfort and reassurance could be given to the person lying and waiting for help. To achieve such a system, a microphone and a speaker is needed.

If someone falls in the staircase, it is important to establish the severity of the situation. This could range from false alarm to severe bodily injury. In any case, communication can help in the decision on what needs to be done. If communication is established, i.e the person using Safestep responds when called upon. Then the fallen individual could describe what state they are in. Should it be a false alarm, then no help gets dispatched and communication stops. Should the individual need assistance, then help is sent. If an elderly person has fallen and is lying injured, keeping a dialogue could also be beneficial for that person by knowing that help is on the way and that that person can experience comfort by having someone to talk to.

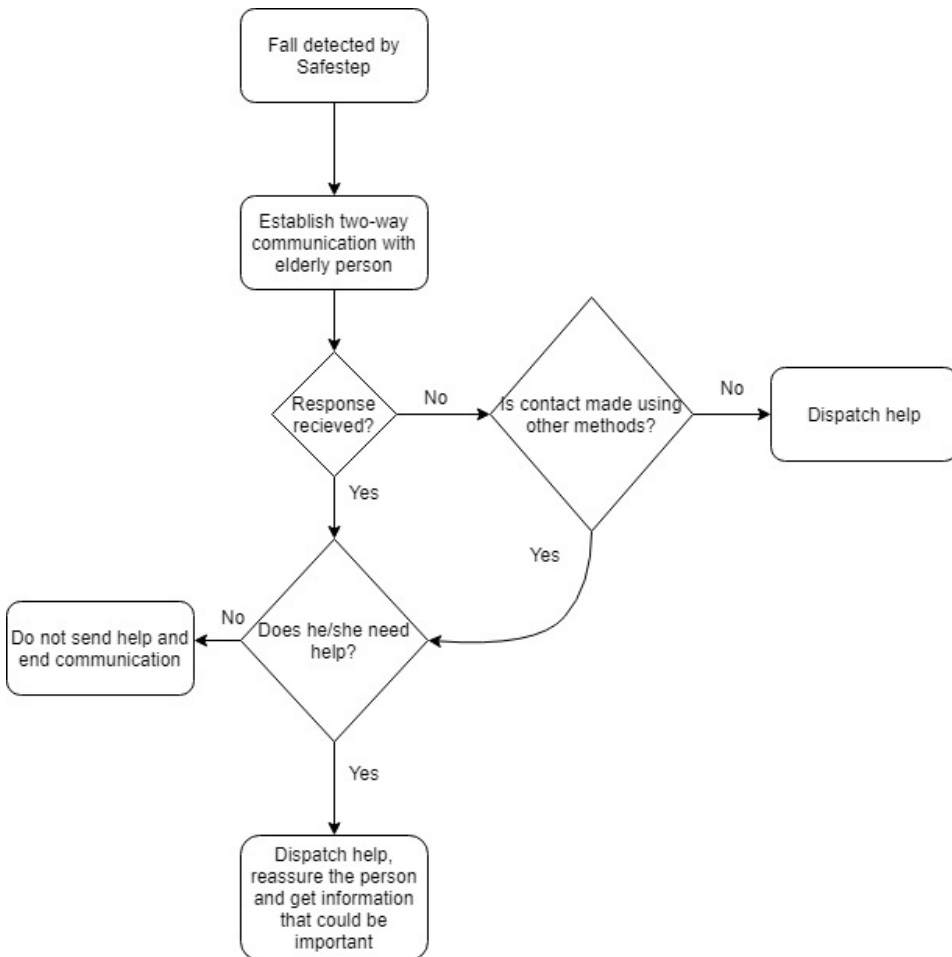

**Figure 14.15:** Flowchart demonstrating communication with a possible fallen person

## 14.8 Observing target group

Observing the target group of Safestep could lead to useful discoveries. The authors of this thesis could be biased when researching the elderly and making assumptions about their behavior. To gain insight into how an elderly with reduced mobility negotiate stairs, one could visit a retirement home and observe how the residents use the stairs. This has not been focused on during the work done on the thesis, but it has been clear that it could be useful. Therefore, what, why and how observations of the target group can be done is briefly listed here.

**What:**

- Observe elderly people negotiate stairs
- Take note of behavioral patterns

**Why:**

- To prevent wrongful assumptions about how elderly walk in stairs
- It is an opportunity to talk to the target group and get input
- Observe how they use their arms for support

**How:**

- Spend time near a staircase at a retirement home
- Videotape, or in other ways record, what might be considered as an important behavior

## 14.9 Discussion and summary

This chapter describes how one could implement more functionalities, and how to test them. The biggest uncertainties related to the potential of Safestep is because what is described here, was not implemented and tested. Most results would have come from this, and without these, Safestep is characterized by many assumptions and suggestions, without many answers and results. Still, the candidates have described a large number of functionalities that could be implemented. All of these might not be necessary for Safestep to perform at a level that qualifies it to be a useful aid, maybe just a few are needed for this. With regards to detecting erroneous data and calculating average values (14.2 and 14.4), these are in a way alternatives to achieve a useful collection of data. The candidates consider the detection of erroneous data to be the most promising of the two.

The biggest uncertainties are concerning measuring heart rate and body temperature. This is also measurements that normally is done using a wearable sensor, with stable contact and enough time to get good readings. The most promising functionalities are the detection of falls, monitoring activity level, measuring stair negotiation time and communication using a microphone and speaker. These also seem to be much easier to implement than temperature and heart rate monitoring. Should the sensors that this thesis focuses on, prove to be inadequate, then the same functionalities should be attempted on alternative sensor models, especially if the results are poor due to slow response time.

For safety reasons, an elderly individual with difficulties negotiating stairs can not be used in initial testing. Such an individual should be included in a later stage. It is noted that this is also a potential cause of misconceptions related to the ideas and assumptions on which tests should be performed and how to do so, because the authors might lack understanding of the target group's situation. To summarise. This chapter describes different functionalities Safestep could have, and how these could work. These include how to check if the sensors perform in a way that adds value to Safestep, how activity level could be measured, how to handle and detect erroneous results and use multiple sensors when detecting falls.



# Chapter 15

## Discussion

This chapter is larger than what might be preferred after what should have been a thorough series of trials and errors and experiences gained from it. However, with the corona outbreak, changes had to be made. Changes involving moving away from a practical focus to a more theoretical one. This results in many uncertainties, which are important to highlight. Therefore this chapter is extensive but also valuable for potential further development.

### 15.1 A marked for Safestep

In the problem description for this thesis, the following was one of the points that were focused on: Identify the potential need for an improved aid that elderly people can use to negotiate stairs, through investigation of existing solutions related to this thesis and relevant theory regarding the target group.

Safestep's target group is elderly people with reduced mobility. Norway is treated as the primary geographical area, but it could extend to other countries as well.

Safestep combines assisting stair negotiation with monitoring of health. These are already offered individually by other products, but none have been found that combines the two.

When looking at already existing solutions available in Norway, Assistep is closest to Safestep in appearance and function. It can also be provided by Hjelpemiddelsentralen. It even appears that this is the only option of its sort in Norway. With that few options, a new aid could be welcomed, but it still remains to see how dominant Assistep is in Norway. To differentiate from Assistep could prove to be very important to be competitive.

Safestep could differentiate from Assistep through the use of its sensors, communication and motorised movement. This provides a lot more than merely help with walking, but there also exist other products that monitor. How the combination of a stair aid and monitoring aid would be perceived by potential users, is difficult to say, but seeing that both types exist, combining the two is not unreasonable to try.

Assistep has the advantage of a more adjustable grip, both with different heights and the possibility to place one's hands anywhere on Assistep. Safestep would have strict re-

quirements as to where hands could be placed and held at different heights would not be an option. This could lead to a less comfortable grip and posture when walking.

The use of a motor to assist moving is another property that could differentiate Safestep in a positive way from other existing products. Stannah is a good comparison regarding this, but with it, the individual does not use his legs at all. Safestep would still allow the individual to walk on his own, but by adding a motor that makes it easier to move Safestep up and down the stairs, a weak upper body does not need to affect the ability to use the stairs. How big a problem it is with reduced upper body strength regarding stair negotiation, is not documented in this thesis, but that it might be, is a valid thought. Safestep would likely be a lot smaller than Assistep, closer to the same size as Stairsteady. This could be an advantage because it would be less noticeable. If someone is reluctant to accept help, a smaller sized aid could lower the threshold one might have for installing an aid for negotiating stairs, but once again, smaller in size also limits the possible ways the users can support themselves on Safestep.

As already mentioned, one might be reluctant to accept that they need assistance. It could be a disappointment to accept that one is no longer able to negotiate stairs on one's own.

Should someone accept that help is needed, what rewards could that person experience through the use of Safestep? A continued independent life, the ability to remain in one's home for longer, a feeling of safety both for the individual himself, but also their next of kin? Society could experience a reward through reduced costs in care for the elderly. Possible rewards are many, but what actually is the case is too soon to know much about. The rewards should also be greater, or at least as great, as any existing product might provide.

With an expected increase in elderly people, the increased need for welfare technology follows. Safestep would be categorised as welfare technology. The different categories described in chapter 3, seem to fit Safestep well. Safestep could generate a sense of safety by reducing the risk of falling and alerting help if needed. It could generate a sense of achievement with elderly people still being able to negotiate stairs, and reducing the need for human assistance. It could also be called examination technology through the use of sensors monitoring the person's health, but how valid this depends largely on the feedback given by medical professionals that could be included later in the development. Qualifying to fit under all these categories is a promising start, but it is no guarantee for success. Safestep would need to fulfill needs not already covered by other types of welfare technology.

Safestep could aid in, what is defined in this thesis as basic activities of daily living (ADLs), when aiding the use of stairs. An autonomous life might be taken for granted as long someone has it, but when something called a basic activity of daily living becomes a tiresome task, reduced quality of life could be the result. How important would stair negotiation be then? For someone living in a multistory home, it could be very important. But if stairs become an obstacle, there are other ways of resolving it, e.g by moving. Moving would be a much more extreme measure, but not uncommon when old age sets in. There is also the financial aspect, an institutionalised person costs society much more than



one who receives home health services. It is not the intention of the candidates to develop an aid that could coerce someone to age in place, but facilitate it. It would be farfetched to attribute Safestep the ability to coerce someone to remain in their home instead of moving into an institution. The sum of welfare technology available, however might lead to an increased pressure towards the elderly to not cost society more money than necessary. And Safestep could add to this sum.

Physical decline is associated with old age. Physical activity is important to slow down the physical decline. Stairs are readily available for the ones who have them in their home. So an aid that facilitates stair negotiation sure seems promising regarding this. But this argument assumes that the stairs are actually being used for exercise, and not necessarily when used for daily life. However, an aid for walking could also be an aid for exercise.

## 15.2 Monitoring

From the problem description: Identify and work with various sensors and hardware that can be used to collect relevant data.

This has been successful and challenging but is also characterised by much uncertainty. In addition to assisting stair negotiation, monitoring would be a big part of Safestep. Safestep tries to bridge the gap between wearable and non-wearable aids. Wearable ones are more suited to monitor health by being able to measure for example respiration rate and blood pressure. The non-wearable have the ability to monitor from a distance and they are also less invasive. People might object to wearing aids because it could send a strong signal that this is someone in need of help or assistance. As already mentioned, accepting that one needs help could be challenging, and maybe even more so if it is visible to others. Non-wearable aids can be disguised in some way to be less noticeable. With different benefits for wearable and non-wearable, it could prove quite useful to try and bridge these two together. But developing something of a hybrid could also mean that compromises need to be made when it comes to performance.

Safestep would clearly not be worn, but with direct contact, it could monitor things that are difficult for non-wearable ones. At the same time, this could lead to less accurate results than what purely wearable ones can achieve. It is also not necessary to remember to wear Safestep. Safestep would therefore be unlikely to be forgotten to use, especially if someone is not able to use the stairs without assistance.

With monitoring technology available and in use today, being accepted by the target group might not be a big challenge. Also, Safestep provides help in areas that are reported to be of interest, e.g mobility and detecting falls. But with Safestep trying to bridge a gap between wearable and non-wearable, the more specialised products might be preferable because these could perform better at their specialised area.

One thing that needs to be implemented to further ensure acceptance, is privacy. How this could be done has not been viewed in this thesis, only what should be considered. Dealing with sensitive information about someone would require a great deal of trust from the users of Safestep. Even though this has not been dealt with extensively by the candidates, its importance must not be underestimated.

The sensors that are worked within this thesis is a reed switch, Single lead Heart rate

monitor- AD8232 from Sparkfun, the AMG8833 thermal camera from Adafruit, FSRs and LM35 temperature sensor. Due to the limited testing of this hardware, it is very difficult to conclude on their suitability. They were also partly chosen to do initial testing. But with these, there have been some results. Indications that monitoring temperature through the skin could be challenging. The biggest problem with this is probably the fact that one alters their grip as they walk, so contact is not constant during stair negotiation. This is most challenging with the LM35 but also with the electrodes attached to the AD8232. A possible solution to this could be to have a spring loaded part under these sensors or flexible foam rubber so that they follow the hand or finger as it moves. With these components being somewhat of an initial guess to what might work, it is also possible, maybe even likely, that other sensors are more suited. Since the candidates only had the opportunity to do some basic testing of the components, the suggested implementation in chapter 14 will provide much more information on how the hardware performs and possibly reveal solutions to what is uncertain now.

Should some sensors prove to not work as intended. They should not be excluded immediately because they might serve other purposes. As described in chapter 14.5, some sensors could work to detect when someone falls, even though their primary use is something else, like the thermal camera. So excluding anything completely without thinking about alternative uses could be premature.

The choice of using Bluetooth to communicate with a stationary device was not based on much other than the need for a way to send data wirelessly, and the fact that the candidates knew that Bluetooth could do this. But it is a popular protocol, that can offer security and privacy. A point regarding privacy in chapter 2 says that one should have "Access to own data". This might be implemented by having a stationary device in the home of where Safestep is installed. So far the description of this stationary device includes few possibilities, the main one is the ability to report that a person is feeling well. But it could be extended to display the data to the individual so that he/she knows at all times what sort of information is being passed on to someone with the Safestep app. The need for a Bluetooth modem originated from the idea that data about the elderly individual needs to be conveyed somehow. Since it was not possible to implement, this is something that at the time being has a few indicators that is useful, other than Bluetooth being used in many different products.

What has been implemented, like detecting fall through the use of reed switch and FSR, and what was intended to implement, like monitoring activity level, seems promising. But how it would work on a handle that moves along a banister is hard to say. There are likely ways to work around many of the challenges that might arise from testing out what is described in chapter 14, but these are not known to the candidates. Some solutions would probably have been revealed as testing had been performed.

## 15.3 App

From the problem description: Lay the foundation for an app that can be used to convey information about the elderly individual.

As recommended the access to the health data should be limited to as few as possible.

This can be done by only giving access to the app for the closest relative and authorised health personnel. This requires the storage of the app to be stored securely, difficult to access for others. It is not found an already existing system for how to handle information about patients. Without a secure system handling the data, it will not be applicable to have an app with such information. How to handle and where to store the health data needs to be looked deeper into to get it secure enough. As mentioned in section 2.2.1 this is not only a concern for the developers but also the users have a concern about how easy the data can be accessed for others. The candidates do not have a background in security and safety and would benefit from help from people more qualified in that field.

The app is intended to be used to collect health data for the user to detect if something is not normal and the users' health should be checked. Store such data over a long period of time will probably give better results for what is out of the ordinary. On the other hand, storing private information over a long time goes against the guidelines from 2.3. It could be smart to include health personnel to decide the amount of information necessary to get the desired information about the user. This could give the opportunity to minimize the amount of data stored from each user.

It can be hard for the elderly to accept new technology when they are not used to technology and can be a bit skeptic about it. They need to be convinced the app will help with something positive and not be a way to spread their information around. The app needs to be user friendly and possible for the users of Safestep to understand.

The app could to some degree, be adjusted to the two main user groups, health care workers and next of kin. The user interface of the app, when used by health care workers, could be based on their educational background. Many who work in health care could have a wide understanding of different technologies, but the safest assumption would probably be their education. The user interface needs to be one that the intended user is qualified to use. The candidates have tried to make an easy user interface, but it could benefit greatly from feedback from the intended users.

With regards to next of kin, this group is far more challenging to adapt to, because they have no such common feature as health care workers might. To spend time and money on developing a different user interface for the next of kin could be unnecessary. What could be beneficial, is how the data is presented to this group. So the main difference with the app being used by a health care professional and a next of kin could be how detailed the data is. It is important to avoid misunderstandings and fear among relatives because of the app.

## 15.4 Design

From the problem description: Prototype, test and design potential solutions.

The design is one of the most visible sides of the work done on Safestep. If the design looks simple enough for the elderly to give them an understanding of what it can be used for, they might get motivated to try it. This combined with how much they trust the technology to be safe will be crucial for the want to use Safestep.

The design of Safestep's handle is made for the users to understand where to put their hands and how to use it, without the need for explanations. This might not be the case, but if someone shows them how to use it, it is a fair assumption that they will manage it.

Without any involvement from the actual users, this is just assumptions that can be difficult for the candidates to verify.

They already have a good insight into how Safestep work and technology in general. With a design that requires specific placement of the hands, it is possible that Safestep loses potential users due to their preferences. Though the design should fit most people's grip, some might have a preferred way of holding. Maybe they want to keep their hands closer together, further apart, one hand on the banister and one on the handle. So far it is not possible to know how many people this could concern, it might not be a noteworthy issue at all. But with the use of sensors that require specific placement of the hands, this issue should be brought up and taken into consideration should further development happen.

Safestep should be an aid for ascending and descending the stairs and at the same time monitor health data. Safestep then needs to be of help in the stairs and not cause any problems, it needs to be safe to use. This includes among other things a design without sharp edges. The design of Safestep is made with rounding any possible sharp edges. Nevertheless using a rack and pinion might include many sharp edges. This rack could be of danger for children and others if they put their fingers inside the track for this. There will be a need to cover the rack up with a housing of some sort.

The design itself is partly based on well known features. As shown in chapter 7 inspiration is gathered from bicycles, strollers and shopping carts. All are products widely used, and it is a sound assumption that these have evolved in a sensible way, to become what they are today. Ascending and descending stairs does add an extra dimension with height, the hands will end up in very different positions than when using a shopping cart. The effects of this difference are luckily not unknown, due to the existing solutions shown in chapter 6. Most similar to Stairsteady, but also Assistep, is the use of horizontal handles laid across the direction of movement.

Most likely, the design can undergo some changes. The sensors and electronics used in this thesis are not customised when it comes to size. Once a decision is made as to what electronics should be used, it would be possible to design PCBs that are specially fitted to Safestep. What this could lead to is too early to say, but an example is that the inner diameter of Safestep could be smaller, making the handle even stronger to external forces.

## **15.5 Possible functionalities and tests**

From the problem description: Describe possible functionalities and tests that can reveal if added value is achieved.

Chapter 14 describes how different systems could work. But the fact that this has not yet been implemented leaves room for much uncertainty. An attempt to describe the reasons for why it could be implemented, and how it could work has been done. Without actually implementing it, it is very hard to think of all the possible outcomes, what challenges could be met and what possibilities it could reveal. The chapter describes a way forward, and what the candidates would have liked to do, but without access to university grounds and equipment, the best alternative was for the candidates to describe their plans. The work prior to the loss of access to school grounds was preparations for practical work. The experience that would have been gained from the practical work would have been cru-

cial for how the candidates could have moved forward. At the same time, without access, the candidates could think of more things that could be implemented. Which gives a wider description of further development. It also gave the candidates more time to reflect on their ideas and provides an even more solid base for further development.

The candidates list some functionalities they consider to be important:

- Identify the added value of each sensor
- how activity level could be measured
- detection of erroneous statistics
- detection of a person falling using more sensors
- combining the use of all the hardware and functionalities.

These are somewhat influenced by the candidates' perception of what could be of importance but also based on the research done. The provided description could reveal the actual value of these functionalities, but they could also be insufficient. Implementation would require a large amount of time and work, and include making a working prototype.

The added value of each sensor means that a sensor should prove useful and work as intended. This is primarily with regards to its main function, but it could be extended to include other functions should there be any.

Measuring activity level could be a way of detecting abnormal behavior, which could be caused by deteriorating health.

Detect erroneous statistics is important to form a valid reference when comparing current values with previous ones.

Using more sensors to detect falling could be useful due to the possibly increased certainty of detecting when a fall occurs. But it could also lead to too strict requirements, thereby leading to some falls going undetected. The balance needs to be between increasing the odds of detecting falls and reducing the risk of false alarms

Finally, the combination of it all. The best possible outcome would be that everything works as intended and adds value to Safestep. However, this is unlikely. At least at the current state of things. Many obstacles could present themselves, and possible ways of resolving some of them. There is a high level of uncertainty regarding the theoretical description of what was supposed to be practical work. The most effective way of resolving this uncertainty is to actually implement it.

The results from these would also be grounds for further discussion. They would not have included an elderly person, due to safety reasons, so if the candidates had performed it themselves, it would be necessary to compare it to how an elderly individual might have done.

The focus on these functionalities and the combination of it all could prove to be what reveals the potential of Safestep, as choices regarding further commitment are made.

## 15.6 The need for Safestep

From the problem description: Based on the work done, conclude if enough promise has been shown for further development to be advised.

The need for Safestep will be influenced by many aspects. The candidates have made their best effort to highlight what they believe to be the most crucial ones. The total sum of knowledge about the target group, existing solutions, potential hardware, design, app and description of further development lays the foundation for any advisement of further development.

Individually these all show both positive and negative signs. How they should be emphasised is still unknown. Should the fact that Assistep seems to be the only option, mean that alternatives have a high chance of success? And would identifying ways to differentiate from it, lead to the conclusion that Safestep would be welcomed by the potential users? Is the combination of assisting stair negotiation and monitoring even doable in a satisfactory way?

The biggest cause of uncertainty is the lack of implementation and testing. Leaving many assumptions and ideas influencing the advisement of further development. During the process working on the development of Safestep, gradually more knowledge around what Safestep has a potential to be has become visible.

Different functions and other possible solutions may have been thought through on a deeper level in this thesis, than if the work had had a larger focus on testing things in practice. On the other hand, testing and building things would probably reveal other possible difficulties not taken into account. This can be used to favor that Safestep should not be further developed.

Problems with the contact between the sensors and the user of Safestep can be a problem. This can make difficulties measuring and might not give Safestep the advantage, compared to other solutions, as wanted. Other difficulties with Safestep can be the alert when the user falls in the stairs. This has not been tested because of the prototype not made and is a critical function. It is necessary for the user to feel safe and get the help needed if they fall.

Despite some discoveries might point towards that Safestep should not be further developed, there are also things pointing to the opposite.

There is expected to be an increase in the elderly in the society. This will lead to a greater need for welfare technology and there are few other alternatives for Assistep in the market today. The need for Safestep will therefore probably only be bigger for years to come.

It is reasonable to assume that the staircase is a place where the use of it, does not change significantly from time to time. So it appears as a good choice of where to monitor changes in a person, especially change in stair negotiation time and activity level.

The candidates are influenced and might be limited by their own ideas and assumptions, it is hard to get out of that mindset. A possible quick solution to uncover potential obstacles could be doing practical work, the results here are likely far less affected by preconceptions.

The complete system has not been made and therefore not been tested. With a complete prototype of Safestep that can assist in stair negotiation and health monitoring, it is believed this is a product that can be needed. Already existing products are either an

aid for negotiation of stairs or monitoring, but Safestep is thought of as a combination of both. If the health monitoring gives relevant enough information needs to be discussed with health professionals.





# Chapter 16

## Further work

This thesis has dealt with what the candidates view as the initial stages of development. In this part of the thesis, what should or could be considered as the next steps in the development of Safestep is described.

Priority is given to parts that, at this stage, is characterised with the most amount of uncertainty.

Parts that still need to be done, but is assumed fully feasible, is given less priority.

### High priority

#### Make a prototype of the complete system

**Suggestion:** A prototype that can be tested in a stair case needs to be build.

**Rationale:** Because it is necessary to be able to perform tests that can give crucial results for further decisions and development. The ideas and assumptions made by the authors are not fully objective, so a prototype can reveal what has not been thought of at this point.

#### Perform tests

**Suggestion:** Chapter 14 describes some functionalities that are possible to implement and tests that can be done, these should be performed.

**Rationale:** These test can provide crucial knowledge on the added value of the different sensors and functions of Safestep. Those results are likely to be a big influence on further decisions

#### Test brake systems

**Suggestion:** Build a prototype of a brake system in full size.

**Rationale:** A brakesystem is important and have to be tested sufficiently to be trusted.

Consider possible changes to make it safer and other systems to test to be sure it is good enough.

## **Include health personell**

**Suggestion:** Get feedback on important health data to measure from health personell with better expertise on the field. The measurements should give added information about Safestep users health.

**Rationale:** It is important that health personell with professional experise within medicin is helping to concider relevant data to measure.

## **Involve people from target group**

**Suggestion:** Interview and get feedback from potential users about the prototype of Safestep. Let them observe the testing and try holding the handle to discuss the usefulness and comfort.

**Rationale:** Safestep is meant to help elderly people, but will not be imposed on them. The user have to see the usefulness and then want to use it.

## **Design**

**Suggestion:** Consider different stairways for any needed change in design of the handle. Look at a possible design change of the attachment mechanism for the handle to fit different banisters.

**Rationale:** It is wanted that Safestep fit in most stairways. If small changes of the design of Safestep can open for use several places, it is smart to consider this already in the design phase. It is not wanted to take decisions that later can exclude use of Safestep places that could be relevant. This can for example be small changes in the length to fit in smaller stairways. Looking at the possibility for generalize the attachment to the banister can make Safestep less expensive, excluding the need for a specialized banister for the use of Safestep.

## **Less priority**

### **Specialised PCBs**

**Suggestion:** The sensors, microcontroller and other electronics used should be mounted on specialised PCBs.

**Rationale:** Components like the Thermal camera from Adafruit and the single lead heart rate monitor from Sparkfun are useful for testing and prototyping. Their size and configuration, however, are not specialised to the intended use of Safestep. With more suitable PCBs, the design and function will move closer towards a fully finished Safestep.

## **Power system**

**Suggestion:** Battery and a charging station for Safestep needs to be included.

**Rationale:** With Safestep moving along a staircase, cords are deemed less suitable than batteries. The battery will power Safestep, and the charging station needs to be easy enough to use that an elderly individual has few to none challenges when using it. It is possible that other ways of powering Safestep is more suited, this might be revealed when working on it.

## **App**

**Suggestion:** Develop communication from Safestep to the tablet and further to the app on the mobiles. Get input from health personell to consider how the health data are presented in the best way.

**Rationale:** Test the whole system with walking in the stairs and sending the health data to check if it the data are understandable in the other end. This could be the start on developing other functions and solutions in the app.

## **Summon Safestep to where one is standing**

**Suggestion:** Include a way of summoning Safestep to the end of the stair case that one is standing at.

**Rationale:** In a household, more than one person might need to use Safestep. If so, it is necessary to summon Safestep to the person who needs it. This can be achieved by adding a button at the top and bottom of the stair case. This can activate a motor and move Safestep automatically towards the one who needs it.

## **Adapting Effects of different illnesses conditions**

**Suggestion:** Investigate the behaviour of different groups of patients with different kind of conditions which may be in Safestep's target group.

**Rationale:** To check if some changes can include more people in the user group of Safestep. This includes both the use of Safestep as a help ascending and descending the stairs and the reading of the sensors. Bigger target group will make the product help more people and earn more money to use for further development and improvement.



# Chapter 17

## Conclusion

This thesis has contributed with a preliminary study that documents opportunities, ideas and possible solutions. All of which are about how assisting elderly people in negotiating stairs and monitor their health, can be done. Due to insufficient implementation, many uncertainties still remain regarding the true potential of Safestep.

Through researching own ideas and assumptions, a target group has been identified and investigated, and a need for an aid like Safestep, has been documented among them. And also, how to differentiate from existing, similar solutions.

Functionalities have been implemented, described and a promising design is shown. A solid base for further development is presented through flow charts, APP, and a computer aided model.

Sensors that have the ability to collect desired data are presented, but their performance and suitability is still characterised by uncertainties. How this data could be conveyed and presented to health care workers and next of kin, is also included.

Descriptions on how the work can move forward is provided. These are based on sound assumptions that aim to add value to Safestep. In total, many parts of a complete system, including a physical design and functionalities, have been developed passed the point of mere assumptions.

The use of an aid like Safestep could increase independence, safety, lead to early interventions and fewer institutionalised individuals. This is in accordance with the governmental goals.

The system described in this thesis is what could be done, considering the time and resource constraints involved. The candidates feel confident that the work done shows promise, and advise the further development of Safestep.



# Bibliography

- [1] *1 av 10 i pensjonsalder må gå i trapper til boligen*, Available at <https://www.ssb.no/bygg-bolig-og-eiendom/artikler-og-publikasjoner/1-av-10-i-pensjonsalder-ma-ga-i-trapper-til-boligen> (Accessed: 15/10/19).
- [2] G. Hjemås, J. Zhiyang, T. Kornstad, and N. M. Stølen, “Arbeidsmarkedet for helsepersonell fram mot 2035,”
- [3] *Ssb befolkning*, Available at <https://www.ssb.no/statbank/table/11667/chartViewColumn/> (Accessed: 30/11/19).
- [4] M. A. B. Jessen, A. V. J. Pallesen, M. Kriegbaum, and M. Kristiansen, “The association between loneliness and health – a survey-based study among middle-aged and older adults in denmark,” *Aging & Mental Health*, vol. 22, no. 10, pp. 1338–1343, Oct. 3, 2018, ISSN: 1360-7863. DOI: 10.1080/13607863.2017.1348480. [Online]. Available: <https://doi.org/10.1080/13607863.2017.1348480> (visited on 10/16/2019).
- [5] J. B. B. Kjølseth, “Safestep. the documentation of a need for, and the design of an aid assisting the elderly with stairnegotiation while monitoring important parameters,” Norwegian University of Science and Technology.
- [6] S.-o. helsedepartementet, *St melding nr 50 (1996-1997)*, Available at [https://www.regjeringen.no/no/dokumenter/st-meld-nr-50\\_1996-97/id191307/](https://www.regjeringen.no/no/dokumenter/st-meld-nr-50_1996-97/id191307/) (Accessed: 13/11/19).
- [7] J. G. Chester and J. L. Rudolph, “Vital signs in older patients: Age-related changes,” *Journal of the American Medical Directors Association*, vol. 12, no. 5, pp. 337–343, 2011.
- [8] H. Mansor, M. H. A. Shukor, S. S. Meskam, N. Q. A. M. Rusli, and N. S. Zamery, “Body temperature measurement for remote health monitoring system,” in *2013 IEEE International Conference on Smart Instrumentation, Measurement and Applications (ICSIMA)*, IEEE, 2013, pp. 1–5.

- [9] *Vital signs (body temperature, pulse rate, respiration rate, blood pressure)*, Available at <https://www.hopkinsmedicine.org/health/conditions-and-diseases/vital-signs-body-temperature-pulse-rate-respiration-rate-blood-pressure> (Accessed: 26/05/20).
- [10] M. Oh-Park, C. Wang, and J. Verghese, "Stair negotiation time in community-dwelling older adults: Normative values and association with functional decline," *Archives of physical medicine and rehabilitation*, vol. 92, no. 12, pp. 2006–2011, 2011.
- [11] M. Oh-Park, S. Perera, and J. Verghese, "Clinically meaningful change in stair negotiation performance in older adults," *Gait & posture*, vol. 36, no. 3, pp. 532–536, 2012.
- [12] L. Boise, K. Wild, N. Mattek, M. Ruhl, H. H. Dodge, and J. Kaye, "Willingness of older adults to share data and privacy concerns after exposure to unobtrusive in-home monitoring," *Gerontechnology: international journal on the fundamental aspects of technology to serve the ageing society*, vol. 11, no. 3, p. 428, 2013.
- [13] G. Demiris, M. J. Rantz, M. A. Aud, K. D. Marek, H. W. Tyrer, M. Skubic, and A. A. Hussam, "Older adults' attitudes towards and perceptions of 'smart home' technologies: A pilot study," *Medical informatics and the Internet in medicine*, vol. 29, no. 2, pp. 87–94, 2004.
- [14] [Online]. Available: <http://sphweb.bumc.bu.edu/otlt/MPH-Modules/SB/BehavioralChangeTheories/BehavioralChangeTheories4.html> (visited on 02/12/2019).
- [15] [Online]. Available: <https://www.merriam-webster.com> (visited on 02/12/2019).
- [16] *Hvordan sikrer vi personvernet i utviklingen av ny velferdsteknologi?* Available at <https://www.datatilsynet.no/personvern-pa-ulike-omrader/forskning-helse-og-velferd/velferdsteknologi/> (Accessed: 15/05/20).
- [17] *Lov om behandling av personopplysninger (personopplysningsloven)*, Available at <https://lovdata.no/dokument/NL/lov/2018-06-15-38> (Accessed: 15/05/20).
- [18] [Online]. Available: <https://www.enviromon.net/home-environment-monitoring-systems/> (visited on 03/12/2019).
- [19] [Online]. Available: <https://mytrusense.com/independent-living-2/how-it-works/> (visited on 03/12/2019).
- [20] [Online]. Available: <https://www.canarycare.co.uk/how-it-works/> (visited on 03/12/2019).
- [21] [Online]. Available: <https://www.biovotion.com/our-solution/> (visited on 03/12/2019).
- [22] [Online]. Available: <https://vitalconnect.com/solutions/vitalpatch/> (visited on 03/12/2019).



- [23] [Online]. Available: <https://www.preventicesolutions.com/patients/body-guardian-heart> (visited on 03/12/2019).
- [24] P. Rashidi and A. Mihailidis, "A survey on ambient-assisted living tools for older adults," *IEEE journal of biomedical and health informatics*, vol. 17, no. 3, pp. 579–590, 2012.
- [25] M. E. B. Skjønsvjell and A. R. Normann, "Monitoring behaviour in a domestic environment: Addressing the needs of an aging population," Master's thesis, Institutt for teknisk kybernetikk, 2012.
- [26] *Velferdsteknologiens ABC - Helsedirektoratet*. [Online]. Available: <https://www.helsedirektoratet.no/brosjyrer/velferdsteknologiens-abc> (visited on 02/11/2019).
- [27] J. Ramm, "Eldres bruk av helse- og omsorgstjenester," p. 110,
- [28] J. Melting and L. Frantzen, "Første gevinstrealiseringsrapport med anbefalinger," *Nasjonalt velferdsteknologiprogram*. Oslo, 2015.
- [29] A. Tichelli, A. Rovó, and J. C. W. Marsh, "Chapter 12 - treatment of elderly patients with aplastic anemia," in *Congenital and Acquired Bone Marrow Failure*, M. D. Aljurf, E. Gluckman, and C. Dufour, Eds., Elsevier, 2017, pp. 141–151, ISBN: 978-0-12-804152-9. DOI: 10.1016/B978-0-12-804152-9.00012-9. [Online]. Available: <http://www.sciencedirect.com/science/article/pii/B9780128041529000129>.
- [30] *Aging in place - an overview — ScienceDirect topics*. [Online]. Available: <https://www.sciencedirect.com/topics/medicine-and-dentistry/aging-in-place> (visited on 10/11/2019).
- [31] M. C. Munkejord, H. Eggebø, and W. Schönfelder, "Hjemme best? en tematisk analyse av eldres fortellinger om omsorg og trygghet i eget hjem home sweet home?" 6-16, 2018, ISSN: 2387-5976. DOI: 10.18261/ISSN.2387-5984-2018-01-03. [Online]. Available: <https://nforsk.brage.unit.no/nforsk-xmlui/handle/11250/2567900> (visited on 11/11/2019).
- [32] G. Hjemås, "Fremskrivninger av etterspørselen etter arbeidskraft i helse- og omsorg mot 2060," p. 107,
- [33] N. Montero-Fernández and J. A. Serra-Rexach, "Role of exercise on sarcopenia in the elderly.," *European journal of physical and rehabilitation medicine*, vol. 49, no. 1, pp. 131–143, 2013.
- [34] M. Giuliani, M. Scopelliti, and F. Fornara, "Elderly people at home: Technological help in everyday activities," in *ROMAN 2005. IEEE International Workshop on Robot and Human Interactive Communication, 2005.*, ISSN: 1944-9445, 1944-9437, Aug. 2005, pp. 365–370. DOI: 10.1109/ROMAN.2005.1513806.
- [35] *Eldre, ensomhet og hjemmesykepleie*, Sykepleien, Apr. 11, 2013. [Online]. Available: <https://sykepleien.no/forskning/2013/04/eldre-ensomhet-og-hjemmesykepleie> (visited on 12/11/2019).
- [36] [Online]. Available: <https://www.who.int/dietphysicalactivity/pa/en/> (visited on 03/12/2019).

- [37] [Online]. Available: [https://www.who.int/dietphysicalactivity/factsheet\\_olderadults/en/](https://www.who.int/dietphysicalactivity/factsheet_olderadults/en/) (visited on 03/12/2019).
- [38] L. Donath, O. Faude, R. Roth, and L. Zahner, "Effects of stair-climbing on balance, gait, strength, resting heart rate, and submaximal endurance in healthy seniors," *Scandinavian journal of medicine & science in sports*, vol. 24, no. 2, e93–e101, 2014.
- [39] [Online]. Available: <http://www.trappekompaniet.no/trappe-info/trappetyper-og-maal/> (visited on 03/12/2019).
- [40] K. C. Teh and A. R. Aziz, "Heart rate, oxygen uptake, and energy cost of ascending and descending the stairs," *Medicine and science in sports and exercise*, vol. 34, no. 4, pp. 695–699, 2002.
- [41] [Online]. Available: <https://www.cdc.gov/nccdphp/sgr/pdf/olderad.pdf> (visited on 03/12/2019).
- [42] [Online]. Available: <https://www.chp.gov.hk/en/static/90006.html> (visited on 03/12/2019).
- [43] *Assistep — experience AssiStep*, <https://assistep.com/experience-the-assistep>, Oct. 2019.
- [44] *Hjelpemiddeldatabasen assistep*, Available at <https://www.hjelpemiddeldatabasen.no/r11x.asp?linkinfo=46259> (Accessed: 26/05/20).
- [45] [Online]. Available: <http://www.stannah.no/> (visited on 03/12/2019).
- [46] *Hjelpemiddeldatabasen stannah*, Available at <https://www.hjelpemiddeldatabasen.no/r11x.asp?linkinfo=41956&newsid=2687&apostid=666> (Accessed: 26/05/20).
- [47] [Online]. Available: <https://stairsteady.net/> (visited on 03/12/2019).
- [48] [Online]. Available: <https://www.hearingandmobility.co.uk/stairsteady> (visited on 02/12/2019).
- [49] [Online]. Available: <http://www.ez-step.com/> (visited on 02/12/2019).
- [50] *Steel k walker handle pediatric*, Available at <https://www.indiamart.com/proddetail/k-walker-handle-pediatric-16845556362.html> (Accessed: 16/05/20).
- [51] *Dmi freedom lightweight folding aluminum rollator walker with adjustable handle height, cushioned flip up seat and convenient storage basket, titanium*, Available at <https://www.amazon.com/Lightweight-Aluminum-Adjustable-Cushioned-Convenient/dp/B000B08GS8> (Accessed: 16/05/20).
- [52] *Comfort fleece walker handle covers*, Available at <https://www.amazon.com/Comfort-Fleece-Walker-Handle-Covers/dp/B06XRYQ6ZT> (Accessed: 16/05/20).
- [53] *Image of stroller*, Available at <https://www.kids-room.com/en/abc-design-turbo-4-stroller-shadow-2020-2020> (Accessed: 16/05/20).

- [54] *Image of shopping cart*, Available at <https://www.piqsels.com/no/public-domain-photo-fpesu> (Accessed: 16/05/20).
- [55] *Image of handle on bicycle*, Available at <https://www.mountainbikeexpert.com/6-reasons-why-mountain-bike-handlebars-are-so-wide/> (Accessed: 16/05/20).
- [56] *Image of elevated handle on bicycle*, Available at [https://www.123rf.com/photo\\_95329528\\_bike-front-gear-switch-brake-lever-and-grip-on-handlebar-on-mountain-bike-.html](https://www.123rf.com/photo_95329528_bike-front-gear-switch-brake-lever-and-grip-on-handlebar-on-mountain-bike-.html) (Accessed: 16/05/20).
- [57] M. Patkin, *A check-list for handle design*, Available at <http://ergonomics.uq.edu.au/eaol/handle.pdf> (Accessed: 20/02/20).
- [58] *Rack and pinion*, Available at <https://www.britannica.com/technology/rack-and-pinion> (Accessed: 16/05/20).
- [59] D. R. Jones and M. F. Ashby, "Chapter 3 - elastic moduli," in *Engineering Materials 1 (Fifth Edition)*, D. R. Jones and M. F. Ashby, Eds., Fifth Edition, Butterworth-Heinemann, 2019, pp. 31–47, ISBN: 978-0-08-102051-7. DOI: <https://doi.org/10.1016/B978-0-08-102051-7.00003-8>. [Online]. Available: <http://www.sciencedirect.com/science/article/pii/B9780081020517000038>.
- [60] D. G. Alciatore, "Introduction to mechatronics and measurement systems," in, 4th ed. MCGRAW-HILL EDUCATION, 2012, ch. 9, pp. 407–414.
- [61] *Image of lm35 from texas instruments*, Available at [https://www.researchgate.net/figure/LM35-sensor-by-Texas-Instrument\\_fig3\\_326028197](https://www.researchgate.net/figure/LM35-sensor-by-Texas-Instrument_fig3_326028197) (Accessed: 03/05/20).
- [62] *Asia on alert with thermal cameras, doctors as ebola declared global risk*, Available at <https://www.reuters.com/article/us-health-ebola-asia/asia-on-alert-with-thermal-cameras-doctors-as-ebola-declared-global-risk-idUSKBN0G80TZ20140808> (Accessed: 02/12/19).
- [63] I. Schelkanova, A. Pandya, A. Muhaseen, G. Saiko, and A. Douplik, "Early optical diagnosis of pressure ulcers," in *Biophotonics for Medical Applications*, Elsevier, 2015, pp. 347–375.
- [64] *The ECG leads: Electrodes, limb leads, chest (precordial) leads, 12-Lead ECG (EKG)*, Available at <https://ecgwaves.com/topic/ekg-ecg-leads-electrodes-systems-limb-chest-precordial/> (Accessed: 20/02/20).
- [65] B.-U. Kohler, C. Hennig, and R. Orglmeister, "The principles of software qrs detection," *IEEE Engineering in Medicine and biology Magazine*, vol. 21, no. 1, pp. 42–57, 2002.
- [66] *Image of a reed switch*, Available at [https://www.sparkfun.com/products/8642?\\_ga=2.71432019.195729286.1584950942-1924013849.1584085371](https://www.sparkfun.com/products/8642?_ga=2.71432019.195729286.1584950942-1924013849.1584085371) (Accessed: 23/03/20).

- [67] *Proximity sensors compared: Inductive, capacitive, phototelectric and ultrasonic*, Available at <https://www.machinedesign.com/sensors/proximity-sensors-compared-inductive-capacitive-photoelectric-and-ultrasonic> (Accessed: 20/11/19).
- [68] D. G. Alciatore, "Introduction to mechatronics and measurement systems," in, 4th ed. MCGRAW-HILL EDUCATION, 2012, ch. 9, pp. 447–451.
- [69] *Pwm duty cycles*, Available at <https://learn.sparkfun.com/tutorials/pulse-width-modulation/all> (Accessed: 27/03/20).
- [70] *Image of h-bridge configuration*, Available at <https://www.build-electronic-circuits.com/h-bridge/> (Accessed: 22/04/20).
- [71] *Drv8871 3.6-a brushed dc motor driver with internal current sense (pwm control)*, Available at <http://www.ti.com/lit/ds/symlink/drv8871.pdf> (Accessed: 22/04/20).
- [72] —, "Introduction to mechatronics and measurement systems," in, 4th ed. MCGRAW-HILL EDUCATION, 2012, ch. 9, pp. 441–446.
- [73] *Motor sizing*, Available at <https://www.orientalmotor.com/technology/motor-sizing-calculations.html> (Accessed: 24/05/20).
- [74] F. Leens, "An introduction to i2c and spi protocols," *IEEE Instrumentation & Measurement Magazine*, vol. 12, no. 1, pp. 8–13, 2009.
- [75] *Serial communication*, Available at <https://learn.sparkfun.com/tutorials/serial-communication/UARTs> (Accessed: 29/05/20).
- [76] *Bluetooth sig*, Available at <https://www.bluetooth.com/> (Accessed: 29/05/20).
- [77] *Image of spp communication*, Available at <https://learn.sparkfun.com/tutorials/bluetooth-basics/bluetooth-profiles> (Accessed: 23/04/20).
- [78] *Serial port profile*, Available at <https://www.bluetooth.com/specifications/profiles-overview/> (Accessed: 26/03/20).
- [79] "Chapter 4 - security management," in *Bluetooth Application Developer's Guide*, D. Kammer, G. McNutt, B. Senese, and J. Bray, Eds., Syngress, 2002, pp. 125–166, ISBN: 9781928994428. DOI: <https://doi.org/10.1016/B978-1-928994-42-8.X5000-9>. [Online]. Available: <https://www.sciencedirect.com/book/9781928994428/bluetooth-application-developers-guide>.
- [80] *Bluetooth basic security*, Available at <https://www.bluetooth.com/blog/bluetooth-security-101/> (Accessed: 26/03/20).
- [81] *Rn42 datasheet*, Available at <https://www.mouser.com/datasheet/2/268/rn-42-ds-v2.32r-268826.pdf> (Accessed: 26/03/20).
- [82] J. Padgette, K. Scarfone, and L. Chen, "Nist special publication 800-121 revision 2, guide to bluetooth security," *National Institute of Standards and Technology (NIST)*, 2017.

- [83] *Arduino nano*, Available at <https://store.arduino.cc/arduino-nano> (Accessed: 29/05/20).
- [84] *Image of the arduino nano*, Available at <http://www.circuitstoday.com/arduino-nano-tutorial-pinout-schematics> (Accessed: 25/03/20).
- [85] *What is zigbee?* Available at <https://zigbeealliance.org/solution/zigbee/> (Accessed: 29/05/20).
- [86] *Image of the sparkfun bluetooth mate silver*, Available at <https://www.sparkfun.com/products/12576> (Accessed: 23/03/20).
- [87] *Sparkfun bluetooth mate gold*, Available at <https://www.sparkfun.com/products/12580> (Accessed: 29/05/20).
- [88] *Image adafruit drv8871 motor driver*, Available at <https://learn.adafruit.com/adafruit-drv8871-brushed-dc-motor-driver-breakout/overview> (Accessed: 01/05/20).
- [89] *Analog devices, ad8232*, Available at <https://www.analog.com/en/products/ad8232.html> (Accessed: 03/05/20).
- [90] *Image of the sparkfun single lead heart rate monitor - ad8232*, Available at <https://www.sparkfun.com/products/12650> (Accessed: 23/03/20).
- [91] *Schematic of sparkfun ad8232*, Feb. 2020. [Online]. Available: [https://cdn.sparkfun.com/datasheets/Sensors/Biometric/AD8232\\_Heart\\_Rate\\_Monitor\\_v10.pdf](https://cdn.sparkfun.com/datasheets/Sensors/Biometric/AD8232_Heart_Rate_Monitor_v10.pdf).
- [92] *Datasheet for ad8232*, Available at: <https://cdn.sparkfun.com/datasheets/Sensors/Biometric/AD8232.pdf> (Accessed: 20/02/20).
- [93] *Ecg: Bmd101*, Available at: <https://store.neurosky.com/products/ecg-bmd101> (Accessed: 20/02/20).
- [94] *Image of the adafruit amg8833 8x8 thermal camera sensor*, Available at <https://www.adafruit.com/product/3538> (Accessed: 23/03/20).
- [95] *Image of the amg8833 from panasonic*, Available at <https://industrial.panasonic.com/cdbs/ww-data/pdf/ADI8000/ADI8000C66.pdf> (Accessed: 01/05/20).
- [96] *Lm35 datasheet*, Available at: <http://www.ti.com/lit/ds/symlink/lm35.pdf> (Accessed: 20/02/20).
- [97] L. Deldossi and D. Zappa, "Iso 5725 and gum: Comparison and comments," *Accreditation and Quality Assurance*, vol. 14, no. 3, pp. 159–166, 2009.
- [98] *Image of an square force sensitive resistor*, Available at <https://www.sparkfun.com/products/9376> (Accessed: 23/03/20).
- [99] *Force sensing resistor integration guide and evaluation parts catalog*, Available at: <https://www.sparkfun.com/datasheets/Sensors/Pressure/fsrguide.pdf> (Accessed: 28/02/20).
- [100] *Voltage divider circuit for fsr*, Available at: <https://www.makerguides.com/fsr-arduino-tutorial/> (Accessed: 28/02/20).

- [101] *Arduino temperature sensor using lm35*, Available at <https://www.instructables.com/id/Arduino-Temperature-Sensor-Using-LM35/> (Accessed: 24/05/20).
- [102] *How Does Orange Influence Your Moods?* en. [Online]. Available: <https://www.verywellmind.com/the-color-psychology-of-orange-2795818> (visited on 05/10/2020).
- [103] *Medieuttrykk og mediesamfunnet - Farger som virkemiddel - NDLA*, nb. [Online]. Available: <https://ndla.no/subjects/subject:1/topic:1:172416/topic:1:172650/resource:1:112508> (visited on 05/10/2020).
- [104] *Individual differences in normal body temperature: Longitudinal big data analysis of patient records*, Available at <https://www.bmj.com/content/359/bmj.j5468.full> (Accessed: 10/05/20).
- [105] *Your heart rate*, Available at <https://www.webmd.com/heart-disease/heart-failure/watching-rate-monitor> (Accessed: 10/05/20).
- [106] *Github repository containing code used in thesis*, Available at <https://github.com/Jarlbbk/Master> (Accessed: 28/05/20).
- [107] *Code to use the sparkfun bluetooth mate silver*, Available at <https://learn.sparkfun.com/tutorials/using-the-bluesmirrf/example-code-using-command-mode> (Accessed: 27/05/20).

# Appendix A

## Setup of strength analysis in Abaqus

Solver: Abaqus standard Part: Removed fillets and smaller geometries to simplify the model. Material: Steel: E-module = 210000MPa, Poisson ratio = 0.3 Step: Linearly elastic solving in analysis

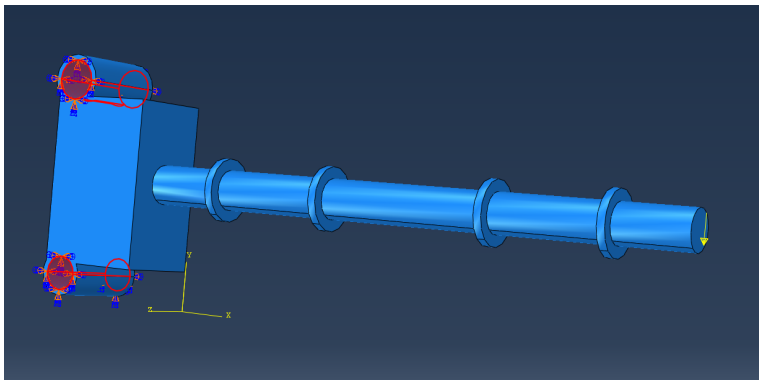

Figure 17.1: Showing specification in the analysis

The red seen in Figure 17.1 is locked in every direction for deformation and rotation:  $U1, U2, U3, UR1, UR2, UR3=0$ . The yellow arrow is a visualization of the 1000N pointing straight down.

**Mesh: 17362 tet-elementer, meshed med free technique: C3D10: A 10-node quadratic tetrahedron. Abaqus standard analysis with 3D elements. Quadratic element formulation**

Matrix from abaqus: Part instance: assembly\_uten\_fillet-1

Tet elements: 17362

Min angle on Tri Faces  $\zeta$  5: 3 (0.0172791%)

Average min angle on tri faces: 35.25, Worst min angle on tri faces: 3.37 Max angle on Tri faces  $\zeta$  170: 0 (0%)

Average max angle on tri faces: 91.00, Worst max angle on tri faces: 146.29 Aspect ratio  $\zeta$  10: 3 (0.0172791%)

Average aspect ratio: 1.81, Worst aspect ratio: 16.96 Shape factor  $\zeta$  0.0001: 0 (0%)

Average shape factor: 0.597296, Worst shape factor: 0.014703

Number of elements : 17362, Analysis errors: 0 (0%), Analysis warnings: 9 (0.0518373%)

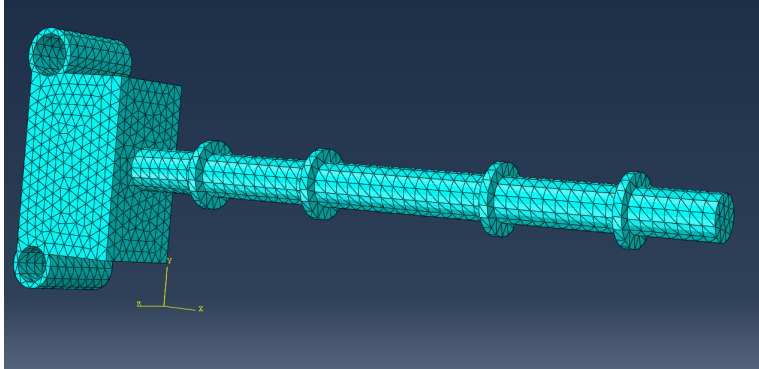

**Figure 17.2:** Abaqus standard analysis with use of quadratic tetrahedron mesh

Job time summary from Abaqus:

USER TIME (SEC) = 13.500

SYSTEM TIME (SEC) = 1.0000

TOTAL CPU TIME (SEC) = 14.500

WALLCLOCK TIME (SEC) = 6



# Appendix B

This appendix contains the code written by the candidates. To use the LM35 and the Sparkfun Bluetooth mate silver, code was found online, and adapted to the needs of the thesis. Apart from the LM35, all other code is object oriented. Classes have been written, each with its own header file and .cpp file. The code can also be found on Github [106]. The different classes can be run individually or combined. A hook up schematic is shown in 12.

## AMG8833 thermal camera

To use the AMG8833 thermal camera from Adafruit, one can use the Adafruit\_AMG88xx library. To download this, the following steps must be taken:

1. Start the Arduino IDE and open the Library Manager
2. Search for AMG88xx
3. Click install

To get all 64 pixel values, use the pixels\_test sketch. To locate it, do the following:

1. Install the Adafruit\_AMG88xx library as instructed above
2. Open up File->Examples->Adafruit\_AMG88xx-> pixels\_test

## LM35 [101]

```
const int sensor=3; // Assigning analog pin A5 to variable 'sensor'  
float tempc; //variable to store temperature in degree Celsius  
float vout; //temporary variable to hold sensor reading  
void setup() {  
pinMode(sensor,INPUT); // Configuring sensor pin as input  
Serial.begin(9600);
```

```

}

void loop() {

vout=analogRead(sensor); //Reading the value from sensor

vout=(vout*500)/1023;

tempc=vout; // Storing value in Degree Celsius

Serial.print(tempc);
Serial.println();

delay(500); //Delay of 1 second for ease of viewing
}

```

## Code for bluetooth

To use the Sparkfun Bluetooth mate silver, code was found online [107]. It can be used as base for when further development might happen. Then the goal would be to pass data between the Arduino and the Safestep app.

.h file:

```

//This code is for bluetooth communication between
//the Bluetooth mate silver from Sparkfun, using the RN-42. This
//is a class 2 Bluetooth, meaning it can transmit up to
//10 meters (class 1 can transmit
// 100 meters, but is unnecessary for this project), class 2
//also consumes less power than class 1
#pragma once
#include <Arduino.h>
#include <SoftwareSerial.h> //allows for serial communication on other
//digital pins than 0 and 1

class Bluetooth
{
private:
    int bluetoothTx; // TX-0 pin of bluetooth mate
    int bluetoothRx; // RX-1 pin of bluetooth mate
    SoftwareSerial bluetooth;
    float* arr;
public:
    Bluetooth(int tx, int rx, float* arr);
    //the array is a pointer
    //to its first elemnt,

```

```

    //must be declared in main loop function
    //it will contain all values that are to be sent
    ~Bluetooth();
    void setup();
    void loop();
};
//data package:
//temp: average temp after passing magnet second time, otherwise 0
//time: 0 during negotiation, time after passing magnet
//pulse: average after passing second magnet, otherwise 0
//fall alarm: only value that is measured and sent during negotiation
//IR camera: average after passing second magnet, otherwise 0

/* if(Serial.available()) //this might be something to add,
//check if there is any data to send over bluetooth
{

    bluetooth.print((char)Serial.read());

}*/

```

.cpp file:

```

#include <Bluetooth.h>
#include <Arduino.h>
#include <SoftwareSerial.h>

Bluetooth::Bluetooth(int tx, int rx, float* arr):
bluetoothTx{tx},
bluetoothRx{rx}, bluetooth(tx,rx), arr{arr}
{
}

void Bluetooth::setup(){
    bluetooth.begin(115200);
    // The Bluetooth Mate defaults to 115200bps
    bluetooth.print("$");
    // Print three times individually
    bluetooth.print("$");
    bluetooth.print("$");
    // Enter command mode
    delay(100);
    // Short delay, wait for the Mate to send back CMD
    bluetooth.println("U,9600,N");
    // Temporarily Change the baudrate
    //to 9600, no parity
    // 115200 can be too fast at times for

```

```

        //NewSoftSerial to relay the data reliably
        bluetooth.begin(9600);
        // Start bluetooth serial at 9600
    }

    void Bluetooth::loop(){
        for (int i=0; i<3;i++){
            //loop the amount of elements in arr
            bluetooth.println(arr[i]);
        }
    }

Bluetooth::~Bluetooth()
{
}

```

## Falling

Code to detect when a person has fallen.

```

    .h file:

#pragma once

#include "Arduino.h"
#include "FSR.h"
#include "Timer_Func_And_Reed_Switch.h"

class Falling
{
    private:
        FSR* fsr;
        Timer_Func_And_Reed_Switch* TFRS;
        int counter;
        int answer;
        int passing_of_magnet;
        int FSR_reading;
        int walking;
    public:
        Falling(FSR* fs , Timer_Func_And_Reed_Switch* T);
        int is_walking();
        int loop();
        ~Falling();
};

```

.cpp file:

```
#include "Arduino.h"
#include "Falling.h"
#include "FSR.h"
#include "Timer_Func_And_Reed_Switch.h"

Falling::Falling(FSR* f, Timer_Func_And_Reed_Switch* TF):
    fsr{f},
    TFRS{TF}, counter{0},
    answer{2}, passing_of_magnet{1}, FSR_reading{0},
    walking{0}
{
}

int Falling::is_walking()
{
    passing_of_magnet = TFRS->proximity();

    if (passing_of_magnet == LOW && counter == 0){
        //check if near the first magnet,
        //if LOW it means the magnet is near
        counter = 1;
    }
    if (passing_of_magnet == HIGH && counter == 1){
        counter = 2;
        answer = 1; //Update answer here because this is
        //when the person has passed the first magnet.
        //If updated when near the first magnet, then
        //it could happen the person changes his mind
        //and does not use the stairs, then it should
        //not alert a fall. And if the person changes
        //his mind and goes back down after passing the
        //first magnet, then he will pass the same magnet again
        //which will update the value for answer to 0,
        //and that is how it should be
    }
    if (passing_of_magnet == LOW && counter == 2){
        counter = 3;
    }
    //has now passed the second magnet
    if (passing_of_magnet == HIGH && counter == 3){
        answer = 0;
    }
}
```

```

        counter = 0;
    }
    return answer; //if return 0, the person is
    //not walking, if 1 person is still walking,
    //if returns 2 the first time walking the
    //stairs since starting the microcontroller
    //has not yet happened
}

int Falling::loop()
{
    FSR_reading = fsr->loop();
    walking = this->is_walking();
    if (FSR_reading <20 && walking == 1) {
        return 1; //FSR_reading is checked
        //against a value indicating
        //that the person is noy holding on,
        //here it is set to 20
    }
    else {
        return 0;
    }
}

Falling::~~Falling()
{
}

```

## Heart rate

Code that can display the ECG values from the Sparkfun single lead heart rate monitor-AD8232.

.h file:

```

//this class is for the use of
// AD8232 Sparkfun Single lead heart rate monitor
//the setup and void function
//are simply what is needed to setup
//and read the input from the AD8232
#pragma once

#include "Arduino.h"

```

```

class EKG
{
    private:
        int ana_pin;
        int dig_low_pin;
        int dig_high_pin;
    public:
        EKG(int ana, int dig_low, int dig_high);
        void setup();
        void loop();
        ~EKG();
};

```

.cpp file:

```
#include "EKG.h"
```

```

EKG::EKG(int ana, int dig_low, int dig_high):
ana_pin{ana}, dig_low_pin{dig_low}, dig_high_pin{dig_high}
{
}

void EKG:: setup()
{
    pinMode(dig_high_pin, INPUT);
    pinMode(dig_low_pin, INPUT);
}

void EKG:: loop()
{
    Serial.println(analogRead(ana_pin));
}

EKG::~~EKG()
{
}

```

## FSR

Code used to read values from the force sensitive resistor.

.h file:

```
#pragma once

#include "Arduino.h"

class FSR
{
    private:
        int pin;
    public:
        FSR(int pinNumber);
        int loop();
        void setup();
};
```

.cpp file:

```
#include "FSR.h"
#include "Arduino.h"

FSR::FSR(int pinNumber) : pin{pinNumber} {}

int FSR::loop()
{
    int ans = analogRead(pin);
    return ans;
}

void FSR::setup()
{
    pinMode(pin, INPUT);
}
```

## Motor

Code for motor control:

.h file:

```
#pragma once
```



```
#include "Arduino.h"
#include "FSR.h"
```

```
class Motor
{
    private:
        const int MOTOR_IN1; //pin to motor driver
        const int MOTOR_IN2; //pin to motor driver
        FSR *fsr;
        int motor_speed;
    public:
        Motor(const int MotorPin1, const int MotorPin2,
              FSR* fsr_ref);
        //the MotorPins must be PWM pins
        // for fsr_ref must first initialize
        //an FSR object, then
        // one must creat an FSR* to that FSR object,
        //this FSR* must go in Motor constructor
        ~Motor();
        void setup();
        void loop();
};
```

.cpp file:

```
#include "Arduino.h"
#include "Motor.h"
#include "FSR.h"
```

```
Motor::Motor(int pin1, int pin2, FSR* fsr_ref) :
MOTOR_IN1{pin1}, MOTOR_IN2{pin2}, fsr(fsr_ref),
motor_speed{0}
{
}
```

```
Motor::~~Motor()
{
}
```

```
void Motor::setup()
{
```

```

        pinMode(MOTOR_IN1, OUTPUT);
        pinMode(MOTOR_IN2, OUTPUT);
    }

    void Motor::loop()
    {
        int FSRreading = fsr->loop();
        motor_speed = map(FSRreading, 0, 1023, 0, 255);
        analogWrite(MOTOR_IN1, motor_speed); //for now this
        //only allows the motor to move in one direction,
        //I need to write to MOTOR_IN2 to get it the other way,
        //this will require the FSR that is located on the other side
    }

```

## Timer functionality using reed switch

Code for measuring the time it takes to ascend and descend the staircase:

.h file:

```

#pragma once
#include "Arduino.h"
class Timer_Func_And_Reed_Switch {
    private:

        const int pin; //the DIGITAL pin for the reed switch
        unsigned long time1;
        unsigned long time2;
        unsigned long total_time;
        int counter;
        int prox; //var proximity

    public:
        int proximity();
        Timer_Func_And_Reed_Switch(int PinNumber);
        void setup();
        int loop();
};

```

.cpp file:

```

#include "Timer_Func_And_Reed_Switch.h"
#include "Arduino.h"

```

```

Timer_Func_And_Reed_Switch::Timer_Func_And_Reed_Switch(int PinNumber) :

```

```

    counter{0}, pin{PinNumber}, time1{0}, time2{0}, total_time{0} {}

void Timer_Func_And_Reed_Switch::setup() {
    pinMode(pin, INPUT_PULLUP);

}

int Timer_Func_And_Reed_Switch::proximity()
{
    return digitalRead(pin);
}

int Timer_Func_And_Reed_Switch::loop() {

    int prox = this ->proximity();
    if (prox == LOW && counter == 0) {
        time1 = millis(); //measure the
        //time at first instance of magnet passing
        counter = 1;
    }

    if (prox == HIGH && counter == 1){
        counter = 2;
    }

    if (prox == LOW && counter == 2){
        time2 = millis(); //time when
        //passing second magnet
        total_time = time2-time1;
        counter = 3;
    }

    if (prox == HIGH && counter == 3) {
        counter = 0;
        return total_time;
    }

}

```