

Evaluation of Energy Transfer Efficiency for Shore-to-Ship Fast Charging Systems

¹Siamak Karimi, ¹Mehdi Zadeh and ^{2,3}Jon Are Suul

¹Department of Marine Technology, Norwegian University of Science and Technology (NTNU), Trondheim, Norway

²Department of Engineering Cybernetics, Norwegian University of Science and Technology (NTNU), Trondheim, Norway

³SINTEF Energy Research, Trondheim, Norway

siamak.karimi@ntnu.no

Abstract— Shore-to-ship charging systems are usually designed based on various operational and design parameters including the onboard power and propulsion requirements, available charging times, and the capability of local power grids. In rural areas with weak grids, onshore energy storages are utilized to enable the high-power charging necessary for vessels with short charging times. However, on-shore energy storage increases the system complexity, and the choice of system configuration can have significant impact on the energy transfer efficiency from the grid to the vessel. This paper presents an energy efficiency comparison between AC, DC and Inductive shore-to-ship charging solutions for short-distanced ferries with AC- and DC-based propulsion. The results demonstrate how an increased share of energy contribution from the onshore battery leads to reduced overall energy efficiency of the charging process. Hence, the energy efficiency should be considered when sharing the load between the grid and the onshore battery. The results show that DC charging is advantageous over other solutions for AC-based propulsion systems in terms of energy efficiency. However, for a DC-based propulsion system, the most efficient solution could be either DC or the AC charging, depending on the load sharing between the grid and onshore battery. Moreover, it is concluded that the inductive charging solution energy efficiency is not far less than the wired schemes, even though it adds more conversion stages and complexity to the system. Considering other advantages of contactless charging, namely, reliability, safety and robustness, these results promote the inductive charging as a promising solution.

Keywords—marine electrification, high-power charging, all-electric propulsion, shipboard power electronics, shore-to-ship fast charging, inductive battery charging systems.

I. INTRODUCTION

Electrification of vessels has become an important and efficient solution for moving toward the zero-emission marine transportation. Existing technologies for reducing emissions include diesel-electric, hybrid and fully battery-electric propulsion systems. While hybrid or plug-in hybrid propulsion systems can reduce the consumption of fossil fuels, fully battery-electric solutions have the potential to almost eliminate emissions from the regular operation. Indeed, hybrid propulsion systems allow for onboard batteries to be recharged by diesel generators or discharged to supply loads, helping the generators to handle the rapid changes in the load profile by peak shaving [1]. Furthermore, another way to recharge the onboard batteries is shore-to-ship charging, which can allow for energy from sustainable sources, such as wind, solar and hydropower available in onshore power systems, to be utilized for supplying propulsion loads in the onboard power system. Thus, shore-

to-ship charging allows for establishing a bridge between the green electric energy and onboard propulsion systems [2].

Over the last years, several short-distanced ferries and vessels for coastal transportation have been developed or planned for operating purely on batteries. Such ferries operate in a tight schedule with limited time for charging from shore between the trips. For instance, MF Ampere, the world's first all-electric car ferry, is operating in the Sognefjord, Norway, between Lavik and Oppdal 34 times per day. At each 10-minute stop between the trips, the ferry's batteries are charged briefly and are charged completely overnight [1]. As another example, MF Tycho Brahe and MF Aurora, two sister hybrid electric ferries from HH ferries, receive electric energy to charge their onboard batteries from shore when they are waiting for loading and unloading, which take 5.5 and 9 minutes at Helsingør and Helsingborg, respectively [3]. With such critical charging times, it is important to take advantage of docking time efficiently, implying the need for fast charging solutions. In this regard, the most common way to provide fast charging is increasing the charging power.

Another challenge of shore-charging systems for motorcar ferries is that they often operate in remote areas with limited capacity of the local power grid at the ports. It means that the local grid may not be able to provide high power for fast charging, and stationary energy storage systems acting as an energy buffer is appearing as a preferred solution for supporting the weak grid [4]. The onshore batteries are then charged while the vessel is away from the dock and/or overnight. However, using stationary battery introduces additional losses in the energy flow from the onshore power system to ship due to the losses generated by the additional power electronics converters interfacing the battery cells and by the battery itself.

Concerning shore to ship charging systems for marine vessels, a few studies can be found in the literature, some of which are mentioned in the following. A design approach and a corresponding control strategy of a high-power inductive charging solution for a plug-in hybrid ferry was proposed in [5] and full-scale demonstration of this system was presented in [4]. The Authors in [2] analyze a harbor-based power system featuring the charging facilities for ships through simulation of two case studies in PSCAD, and also presents the technical challenges and practical considerations of such harbor configurations. In [6], the charging strategy for a fully-electric ship is assessed in terms of battery sizing and lifetime. Furthermore, [7] optimizes the charging problem for a river transport boat by means of Mixed-Integer Linear Programming (MILP). However, there has been no study on

the performance assessment for different shore charging solutions with different power architectures.

To design and control a shore charging system, energy efficiency which indicates the ratio of electric energy stored in the onboard battery over the electric energy drawn from the onshore grid for a round of the vessel operation can play an important role as a performance index. This energy efficiency depends on the system configuration and varies with the charging parameters, for example the charging power and the load sharing between the grid and the onshore battery.

In this paper, an evaluation of the energy transfer efficiency of shore-to-ship charging for three charging solutions, i.e., AC, DC and inductive charging systems is presented. The evaluation is conducted for two different onboard power system architectures i.e., AC main-bus and DC main-bus propulsion system. The charging scenarios are introduced in the next section, and then the power loss models for calculating the energy efficiency are presented. A case study for the analysis based on a passenger ferry is presented in section IV. Furthermore, the design characteristics of the power converters, battery energy storage systems and other components are also introduced in section IV. At the end, the results of the energy efficiency evaluation are analyzed in the section V.

II. SHORE-TO-SHIP CHARGING SYSTEMS

From a power system point of view, shore charging systems consist of four main components: the grid interface, the onshore Battery Energy Storage System (BESS), the shore-to-ship connection and the onboard charger. The grid interface and the onshore BESS, in parallel, supply the onboard charger through the shore-to-ship connection to recharge the onboard batteries. Below, the most relevant charging system topologies for high-power charging are described, such as AC charging, DC charging and inductive charging.

A. AC charging systems

In Fig. 1 (a), an AC shore charging power system connecting to a single-bus DC hybrid onboard power system is depicted. The red lines show the charging path from shore to ship. Even though in most practical propulsion systems there are more than one single bus operating in parallel, only a single bus is drawn for simplicity. The onshore batteries are typically charged by the grid overnight or in off-peak hours in order to not only decrease the stress on the local grid, but also utilize cheaper electricity. Transformer T12 is a 50Hz transformer stepping down the grid voltage into the shore bus voltage and galvanically isolating the shore bus from the grid. Converter C15, which can be a diode rectifier or an active rectifier, rectifies the received energy from. Bi-directional DC-DC Converter C12 directly connected to onboard battery B11 controls transferred power during charging and discharging process. Similarly, converter C17 is performing as a power controller for the onshore battery B12. The two-level voltage source converter C16 performs as a rectifier during onshore battery charging and as an inverter during onboard battery charging. In Fig. 1(b), the shore charging power system is the same as that in Fig. 1(a), but it is connected to an AC-based propulsion system, so there is no need for a dedicated rectifier. In other words, bidirectional

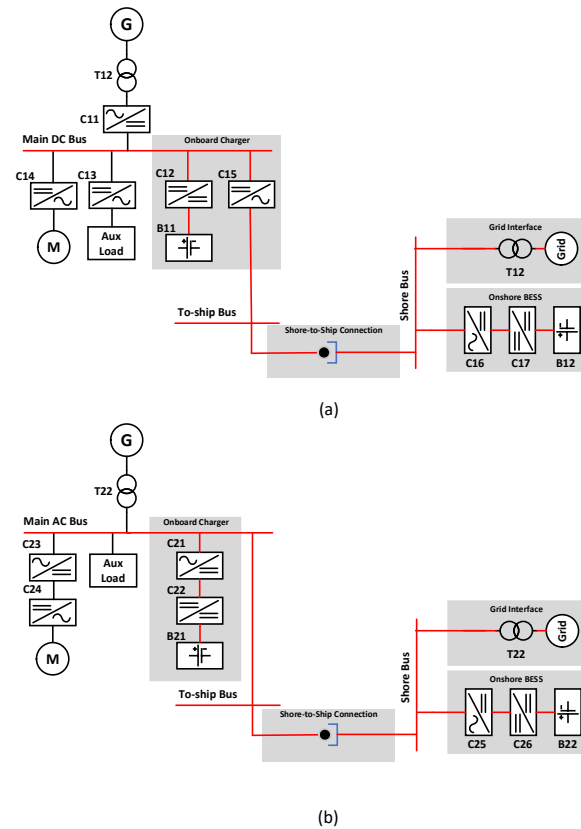

Fig. 1. AC charging for (a) a DC-based propulsion system and (b) an AC-based propulsion system

converter C21 and converter C22, which are interfacing the onboards batteries to the main AC bus, rectify and control the received charging energy.

Considering an AC charging solution for an AC-based propulsion system as shown in Fig. 1(d), it would be necessary to synchronize the voltage, phase and frequency of the onboard power system to the onshore power system before connection, since connecting with voltages out of phase would lead to severe inrush currents. The only exception would be if the onboard power system is completely passive (with zero voltage) before connecting to the shore power system. It is worth mentioning that in shore power supply, i.e. cold ironing, there is often an onshore 50/60 Hz frequency converter since the onboard AC bus is usually 60 Hz unlike the onshore AC system in Europe. In that case, the synchronization process would be carried out in the frequency converter which makes this process much faster than other the system without such frequency converters. [8].

B. DC charging systems

In maritime vessels, there are volume and weight constraints, similar to electric vehicles, especially for pure battery-electric ships. Hence, removing onboard rectifier and onboard low frequency transformer to reduce weight and to reduce the number of onboard power conversion stages in the shore-to-ship charging path can be relevant step towards increasing the available range and achieving more efficient zero emission battery-based marine transportation. For instance, the "Future of the fjords", which is an all-electric passenger catamaran made of carbon fiber composite, is

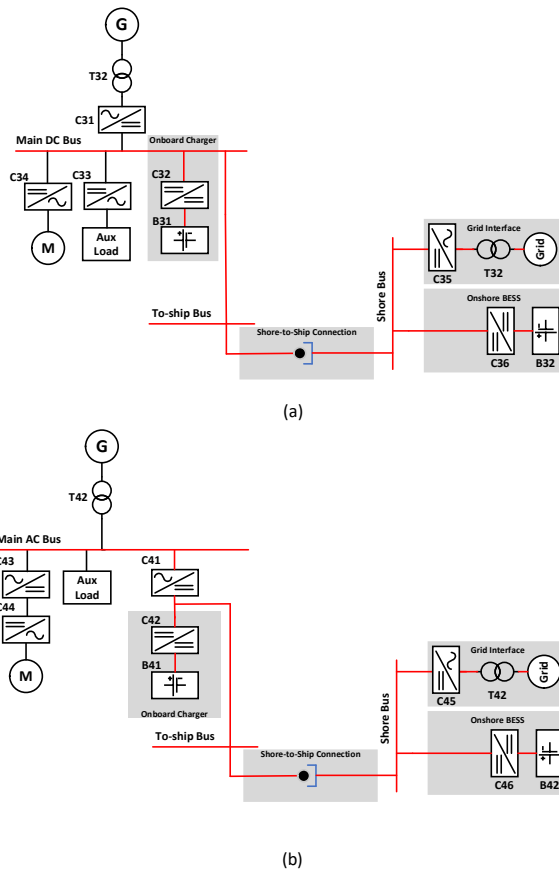

Fig. 2. DC charging for (a) a DC-based propulsion system and (b) an AC-based propulsion system

using a 1000V DC connection for charging from shore aiming in reduced weight of the vessel [9]. Fig. 2(a) shows a DC shore charging power system connecting to a single-bus DC hybrid onboard power system. By comparing the power converters in Fig. 2(a) with those in Fig. 2(a), it is obvious that converter C15 is relocated from onboard to onshore, as converter C35. However, these two converters do not necessarily have the same rating and topology, so their influence on the energy efficiency will not be equal. In Fig. 2 (b), a DC shore charging solution for an AC-based hybrid propulsion system is drawn. The to-ship bus is connected to the input of converter C42, so the charging path is the same as that in Fig. 2(a). Note that if there are any AC loads during the docking, it is better to invert the receiving energy through converter C41, energizing the main bus.

C. Inductive charging systems

In inductive charging, the electric energy is transferred through the magnetic field between the coils, rather than conduction through the plug and the receptacle. Being more time-efficient by eliminating the connection and disconnection time, less vulnerable to the harsh weather and saline water as well as inherent galvanic isolation are the most important advantages of wireless charging solution compared to the wired solutions for the marine vessels [4].

In inductive power transfer, the transmitter and receiver coils act like a transformer with a low mutual inductance. The relatively low magnetic coupling results in a high magnetizing current, so capacitive compensation networks, P51 and P52 in Fig. 3, are used for generating the reactive

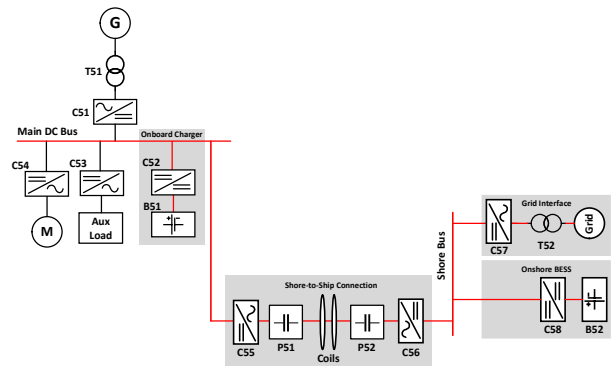

Fig. 3. Inductive charging for a DC-based propulsion system

power consumed by the coils. Converter C56 which is a full-bridge inverter generates a high frequency (several kHz) square wave voltage. Converter C55 in Fig. 3 is a full-bridge diode rectifier which converts the high frequency output of the receiver coil to DC suitable for charging the onboard battery. As it can be seen, transmitter and receiver coils provide galvanic isolation, obviating the need for a low onboard low frequency transformer.

III. POWER LOSS MODEL OF THE CHARGING SYSTEM

In this section, the power loss models for components included in the charging path are presented

A. Two-level voltage source converter

In this study, a three phase SPWM inverter with six IGBTs and anti-parallel diodes with injection of third harmonics is considered as the bidirectional AC-DC conversion stage interfacing the battery and the AC grid to the AC bus and DC bus, respectively. It is shown in Fig. 4. Power loss associated with this converter is categorized into two parts: 1) Conduction loss 2) switching power loss.

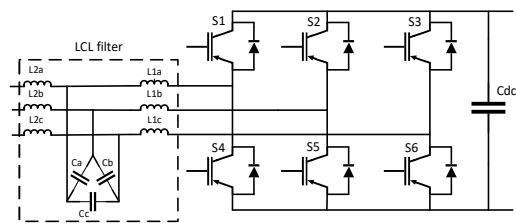

Fig. 4. Two-level voltage source converter with LCL filter

The output characteristic of an IGBT is linearized as a straight slope as follows [10].

$$V_{CEsat}(t) = V_{CE0} + r_{CE}i_c(t) \quad (1)$$

Thus, the conduction power loss of an IGBT in a two level VSC may be calculated according to:

$$P_{Cond loss T} = \frac{1}{T} \int_0^T V_{CEsat}(t)i_c(t)Ddt \quad (2)$$

Assuming sinusoidal currents, and an ideal duty cycle, the conduction loss of an IGBT will be calculated by the following expression [11]:

$$P_{Cond loss T} = \left(\frac{1}{2\pi} + \frac{m \cos(\theta)}{8} \right) V_{CE0} I_c + \left(\frac{1}{8} + \frac{m \cos(\theta)}{3\pi} \right) r_{CE} I_c^2 \quad (3)$$

Where m , I_c , ω and θ are modulation factor, peak value of the output current, the frequency of output signal and the phase shift of the output current and the fundamental harmonic of output AC voltage.

Similar to the aforementioned method for calculation of conduction loss for IGBTs, the on-state power dissipation of a diode is calculated by the following expression [11].

$$P_{Cond loss D} = \left(\frac{1}{2\pi} - \frac{m \cos(\theta)}{8} \right) V_{FW0} I_D + \left(\frac{1}{8} - \frac{m \cos(\theta)}{3\pi} \right) r_F I_D^2 \quad (4)$$

The following expressions are used to calculate the power loss generated in the DC link and LCL filters which may be negligible compared to the other power loss terms.

$$P_{Cdc loss} = r_{Cdc} (2\pi f_{sw} C_{DC} \Delta V_{DC}) \quad (5)$$

$$P_{LCL cond loss} = 3(r_{L1} + r_{L2}) I_{out}^2 \quad (6)$$

r_{Cdc} , r_{L1} and r_{L2} are the Equivalent Series Resistance (ESR) of the DC link capacitor and inductors in the LCL filter and respectively. ΔV_{DC} is also the DC link voltage ripple. Based on the switching loss characteristics of IGBTs provided in their datasheet, turning on and turning off switching loss are linearly and nonlinearly dependent on the collector current and the blocking voltage, respectively. In this regard, the approximated expression for IGBT switching loss is in the following [10].

$$P_{sw loss T} = \frac{\sqrt{2} f_{sw} (E_{on} + E_{off}) I_{out}}{\pi} \left(\frac{V_{cc}}{V_{ref}} \right)^{1.3} \quad (7)$$

E_{on} and E_{off} are turning on, turning off energy loss with respect to reference voltage and current, V_{ref} and I_{ref} , in the datasheet. For diodes, only the turning off power loss, E_{rr} , caused by the reverse recovery current is taken into account [10].

$$P_{sw loss D} = \frac{\sqrt{2} f_{sw} (E_{rr})}{\pi} \left(\frac{I_{out}}{I_{ref}} \right)^{0.6} \left(\frac{V_{cc}}{V_{ref}} \right)^{0.6} \quad (8)$$

B. Bidirectional DC/DC converter

In this paper, a buck/boost converter, shown in Fig. 5(a), is chosen as the power controller for the battery energy storage systems. It acts as a buck when the battery is charging and as a boost when the battery is discharging. The power loss components are 1) conduction loss and 2) switching loss. The averaged conduction loss is calculated by the linear approximation of output characteristics of the IGBT and the diode, as it is shown below [12].

$$P_{Cond loss T} = DV_{CE0} I_{Lb} + Dr_{CE} I_{Lb}^2 \quad (9)$$

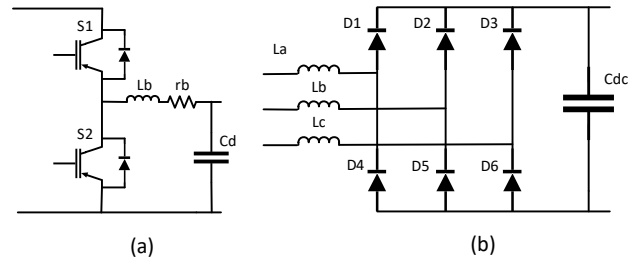

Fig. 5. (a) bidirectional buck/boost converter and (b) Three phase diode rectifier

$$P_{Cond loss D} = (1 - D)V_{FW0} I_{Lb} + (1 - D)r_F I_{Lb}^2 \quad (10)$$

$$P_{res loss Lb} = r_{Lb} I_{Lb}^2 \quad (11)$$

Where r_{Lb} and I_{Lb} are the measured resistance and the current of the boost inductor, respectively. D is the duty cycle of the converter which is the ratio of the battery voltage over DC bus voltage. The switching loss of the transistor and the diode are calculated as follows [10].

$$P_{sw loss T} = f_{sw} (E_{on} + E_{off}) \frac{I_{out}}{I_{ref}} \left(\frac{V_{cc}}{V_{ref}} \right)^{1.3} \quad (12)$$

$$P_{sw loss D} = f_{sw} E_{rr} \left(\frac{I_{out}}{I_{ref}} \right)^{0.6} \left(\frac{V_{cc}}{V_{ref}} \right)^{0.6} \quad (13)$$

C. Three-phase diode rectifier

For converting AC into DC in cases which there is no need for controlling the voltage and power, using a diode rectifier, as it is depicted in Fig. 5(b), is a proper choice. Diodes are modeled as a constant voltage source and a resistance. Further, since the frequency is 50 or 60 Hz turning off power loss is negligible. The averaged conduction power loss for a diode rectifier is calculated by the following expression, in which I_{dc} is the current in the DC side of the rectifier [13].

$$P_{Cond loss D} = 2V_{FW0} I_{dc} + \frac{\pi}{3} r_F I_{dc}^2 \quad (14)$$

D. Inductive power transfer

As it is shown in Fig. 6, an inductive power transfer system comprises of an inverter, a pair of transmitter and receiver coils with dedicated compensation networks, series capacitors C_t and C_r , and a rectifier in the receiving side. Therefore, in order to calculate the system efficiency, each part should be analyzed in terms of power efficiency, separately.

The inductive Power Transfer Efficiency (PTE) at the resonance frequency ($\omega_0 = \frac{1}{\sqrt{L_t C_t}} = \frac{1}{\sqrt{L_r C_r}}$) through the resonance network is calculated by the following expression which varies with the mutual inductance, M and the load conditions. R_L , R_t and R_r are the equivalent resistances of the coils and series capacitors in the transmitting and receiving sides [14].

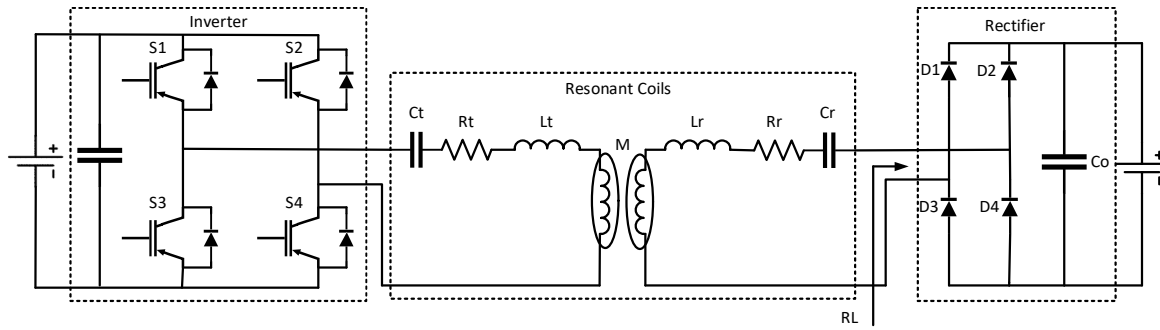

Fig. 6. Schematics of the inductive power transfer used for wireless charging

$$PTE = \frac{R_L(\omega_0 M)^2}{((R_s + R_t)(R_L + R_r) + (\omega_0 M)^2)(R_L + R_r)} \quad (15)$$

Based on the control strategy presented in [5], a variable switching frequency scheme can be utilized to adopt to the changes in the coupling factor caused by variation in the distance between the coils. Further, such switching frequency variation is not affecting the efficiency according to the study carried out in [15]. Thus, it can be a reasonable assumption to consider the efficiency of the resonance network in a inductive power transfer constant.

Then, for the inverter, the turning on power loss is negligible because of the Zero-Voltage Switching (ZVS) due to the lagged resonant current caused by resonant inductances. Thus, the inverter power loss composed of conduction power loss and turning off switching power loss [16]. The first term is calculated by considering fundamental harmonic of the input current into expressions (1) and (2) for a full bridge configuration. Further, the switching power loss is calculated as in (5) but with replacing the $(E_{on} + E_{off})$ with (E_{off}) . Regarding the rectifier power loss, the conduction power loss and the reverse recovery power loss are calculated by (12) and (11).

E. Battery

The energy loss of the battery results in a difference between the energy required for charging a battery and the energy released of discharging it for a certain amount of depth of discharge. Thus, for evaluating the system efficiency the battery efficiency should be considered. This efficiency is dependent on charging current and SoC and mode of operation, either charging or discharging process. Although many detailed and advanced models have been developed and studied, a simplified equivalent circuit as shown in Fig. 7 is applied in this paper for evaluating only the power loss. In this circuit, r_d and r_c are modeling the power loss generated in the discharging and charging process [17].

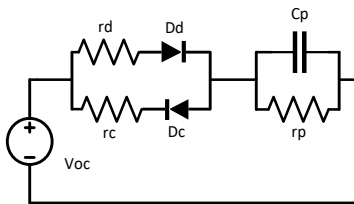

Fig. 7. Li-ion battery model

To calculate the power loss in the battery, the following expression is used, in which n_s , n_p , r_b , P_{bat} and V_{bat} are the

number of cells in series and parallel, the internal resistance of the battery, the power and the voltage of the battery array [17].

$$P_{loss\ Battery} = \frac{n_s}{n_p} r_b \left(\frac{P_{bat}}{V_{bat}} \right)^2 \quad (16)$$

F. Power transformer

A 50 or 60 Hz distribution transformer interfaces the grid into the charging station. A power transformer generates two power loss components: 1) No load power loss which is dependent on the voltage and 2) copper loss which is dependent on the load. Thus, by extracting the no load and copper power loss of a transformer, the transformer power loss may be calculated by the following expression.

$$P_{TR\ loss} = P_{no\ load} + P_{cu} \left(\frac{P_{load}}{P_{rated}} \right)^2 \quad (17)$$

IV. CASE STUDY

In this work, short-distanced ferry is considered. Therefore, the schedule of this ferry can affect the charging regimes, which are opportunity charging during the day. Further, the charging program for onshore battery packs is another matter of concern. In order to calculate the energy efficiency of a charging system, it is necessary to determine the charging plan and sizing of the converters which leads to selection of switches.

In this regard, the schedule of the ferry consists of two stops for 15 min each and two trips for 30 min each. In other words, it takes 75 min that the ferry comes back to a charging station, meaning that the onshore batteries are required to recharge within the time period of 75 minutes. The characteristics of the charging plan and the design parameters of the charging scenarios are listed in the Table I.

In this paper, the inductive power transfer is designed for transferring maximum power of 600 kW [15]. Table II shows the design parameters of the inductive charging system that take part in the energy efficiency calculations.

V. RESULTS AND DISCUSSION

The methodology for calculating of energy efficiency used in this paper, is based on utilization of the aforementioned power loss models for evaluating the total energy drawn from the grid, directly and indirectly through the onshore battery, for supplying the required energy to the battery. For evaluating one charging cycle, the power flow and the losses are calculated for 90-minute operation of the

TABLE I. DESIGN PARAMETERS

Parameters	Symbol	Value
Onshore battery capacity and nominal voltage	C_{OSB}, V_{OSB}	400kWh, 650V
Li-ion battery internal resistances for charging and discharging [18]	r_c, r_d	15 mΩ, 10 mΩ
Onshore battery discharging power	P_B	100~500kW
Onshore battery charging power	P_{c-OSB}	100~500kW
Grid power (11kV, 50Hz)	P_G	100~500kW
Onboard battery charging time	t_{c-ONB}	15min
Onshore battery charging time	t_{c-OSB}	75min
Onboard charging energy	E_{c-ONB}	150kWh
Grid-interface transformer nominal power and voltage ratio		1MVA, 11kV:0.69kV
Grid-interface transformer nominal no load and full load power loss [19]	P_{nl}, P_{Cu}	2kW, 10kW
Main onboard DC bus voltage	V_{DC}	980V
Main onboard AC bus voltage	V_{AC}	690V
IGBT's ratings (FF1000R17IE4P)	$V_{CES}, I_{C\ nom}$	1.7 kV, 1 kA
Diode's ratings (SKKD 701)	V_{RSM}, I_{FAV}	1.7 kV, 701 A

different solutions. It is assumed that the voltage of the batteries remains constant at their nominal value due to the small change of SoC during opportunity charging. Since the power loss of the power components are dependent on the operation point, the energy efficiency would change as the required charging power and charging schemes change. One of the factors that affect the energy efficiency is the ratio of the direct charging power from the grid and the indirect charging power from the grid through the onshore BESS, which is determined in system-level control.

On this basis, the energy efficiency curves for various ratios of the direct power to the indirect power are depicted in the Fig. 8. By carefully studying the efficiency curves, the following points can be concluded:

- 1- The higher ratio of the grid power to the onshore battery power contributing to the charging process, the higher energy efficiency of the system. This is because of the energy losses generated in the onshore battery charging and discharging process including the internal energy loss of BESS. However, as the share of onshore battery increases,

TABLE II. INDUCTIVE CHARGING DESIGN PARAMETERS

Parameters	Symbol	Value
Self-inductances	L_v, L_r	400μH
Mutual inductance	M_{min}, M_{maxi}	80μH, 200μH
Coil resistances	R_v, R_r	40mΩ
Resonance frequency	f_r	3kHz

the stress on the grid for supporting the charging load decreases. Thus, such ratio should be optimized with respect to the energy efficiency and the local grid capability.

- 2- Inductive charging systems efficiency is not far less than wired solutions. Rather, with the applied parameters it is always more energy efficient than the AC solution from Fig. 8 (b), and more efficient than AC solution in Fig. 8(a) for $\frac{P_G}{P_B} < 0.54$. In fact, zero voltage switching in the inductive charging system causes the reduction of switching power loss. Although the energy efficiency of DC solution is always higher than that for Inductive solution, the wireless charging presents some unparalleled advantages, namely elimination of mechanical issues of plugs and cables and adjustability for harsh weather and sea levels.
- 3- For a ferry with a main DC bus, the most efficient solution with the applied parameters is DC charging for $\frac{P_G}{P_B} < 0.83$. Otherwise, the AC charging is the most efficient scenario. It is because the voltage source converter C35 in Fig. 2(a) generates more power loss than the diode rectifier C15 in Fig. 1(a) due to the IGBT switching power loss. It is worth mentioning that concerning the purpose of using onshore energy storage, The DC charging is the most efficient choice as the energy ratio of the grid to the battery not more than 1. For instance, take points E1 and E2, the energy efficiency is improved by 1.2% with substituting the AC charging system with a DC charging solution. If the ferry has 10 trips per day and draws 150kWh energy from the grid at two ports, the saved energy within a month would be approximately equal to the energy required for a whole day of operation.

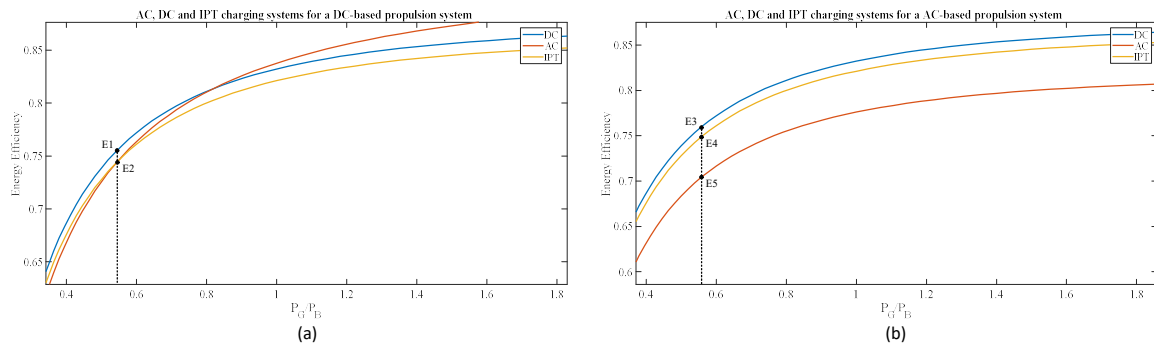

Fig. 8. Overall energy efficiency curves for different charging solutions (IPT stands for Inductive Power Transfer) used for (a) DC-based propulsion system and (b) AC-based propulsion system.

- 4- For a ferry with a main AC bus, the most efficient solution is a DC-coupled charging station. This is because the energy from the onshore battery is converted into AC at shore bus and converted back to DC to charge the onboard battery, in the AC charging. By contrast, in the DC charging system, the onshore battery discharging path to the onboard does not include any DC-AC conversion stages. For example, take points E3 and E5, the energy efficiency is improved by 4% with substituting the AC charging system with a DC charging solution. By so doing, the saved energy within a month would be approximately equal to the energy required for more than two days of operation.

VI. CONCLUSION

In this work, three power system architectures for charging an AC-based or a DC-based hybrid propulsion system are studied in terms of energy efficiency. By considering the load-dependent power loss models, the dependency of the overall energy efficiency with respect to the load-sharing ratios between the onshore battery and the grid are identified and analyzed. From these results it is concluded that the DC charging and Inductive charging are more energy efficient than AC charging for a ferry with an AC propulsion system. However, for the other type of ferries with a DC-based onboard power system, based on the charging parameters either DC or AC charging could be the most efficient one. In addition, the results show that a wireless charging system does not have to imply significantly lower energy efficiency than conductive charging depending on the charging configuration and the parameters. This implies that there can be potential for justifying the marginally lower energy transfer efficiency for taking advantage of the practical benefits of wireless charging technology.

REFERENCES

- [1] P. Ghimire, D. Park, M. K. Zadeh, J. Thorstensen and E. Pedersen, "Shipboard Electric Power Conversion: System Architecture, Applications, Control, and Challenges [Technology Leaders]," *IEEE Electrification Magazine*, vol. 7, no. 4, pp. 6-20, 2019.
- [2] J. Kumar, A. Memon, L. Kumpulainen, K. Kauhaniemi and O. Palizban, "Design and Analysis of New Harbour Grid Models to Facilitate Multiple Scenarios of Battery Charging and Onshore Supply for Modern Vessels," *Energies*, 2019.
- [3] "Tycho Brahe Hybrid Ferry Case Story," [Online]. Available: <https://www.deif.no/marine-and-offshore/cases/tycho-brahe>. [Accessed 5 12 2019].
- [4] G. Guidi, J. A. Suul, F. Jensen and I. Sorfonn, "Wireless Charging for Ships: High-Power Inductive Charging for Battery Electric and Plug-In Hybrid Vessels," *IEEE Electrification Magazine*, vol. 5, no. 3, pp. 22-32, 2017.
- [5] J. A. S. Giuseppe Guidi, "Minimization of Converter Ratings for MW-scale Inductive Charger Operated under Widely Variable Coupling Conditions," in *Proceedings of the IEEE PELS Workshop on Emerging Technologies: Wireless Power, 2015 WoW*, Daejeon, Korea, June 2015.
- [6] S. t. C. Hoedemaker, "Battery aging in full electric ships," Master's thesis, Delft University of Technology, 2017.
- [7] D. Villa, A. Montoya and J. M. Ciro, "The electric boat charging problem," *Production*, vol. 29, Sep. 2019.
- [8] G. B. M. M. S. S. S. a. M. J. R. Smolenski, "Ship-to-Shore Versus Shore-to-Ship Synchronization Strategy," *IEEE Transactions on Energy Conversion*, vol. 33, no. 4, pp. 1787-1796, Dec. 2018.
- [9] A. Aa, "Brodrene Aa and The Fjords pioneering with "Future of The Fjords" – offering zero emission fjord cruise," [Online]. Available: <https://static1.squarespace.com/static/5b18ec3ee1759b32d884907/t/5ca7401a419202c6a737dac1/1554464803172/2019+04+Article+Future+of+The+Fjords.pdf>. [Accessed 10 12 2019].
- [10] A. Wintrich, U. Nicolai, W. Tursky and T. Reimann, "Application Manual Power Semiconductors," SEMIKRON International GmbH, Illmenau, Germany, 2015.
- [11] M. H. Bierhoff and F. W. Fuchs, "Semiconductor losses in voltage source and current source IGBT converters based on analytical derivation," in *2004 IEEE 35th Annual Power Electronics Specialists Conference*, Aachen, Germany, 2004.
- [12] J. Zhang, "Bidirectional DC-DC Power Converter Design Optimization, Modeling and Control," in *PhD Dissertation*, Blacksburg, Virginia, Virginia Polytechnic Institute and State University, 2008.
- [13] B. Z. a. L. E. Norum, "Efficiency analysis of shipboard dc power systems," in *IECON 2013 - 39th Annual Conference of the IEEE Industrial Electronics Society*, Vienna, 2013.
- [14] Vilathgamuwa D.M., Sampath J.P.K. , "Wireless Power Transfer (WPT) for Electric Vehicles (EVs)—Present and Future Trends," in *Plug In Electric Vehicles in Smart Grids*, Singapore, Springer, 2015.
- [15] A. Kjellevoll, "Analysis and control of inductive power transfer systems for wireless battery charging in subsea applications," in *Master's Thesis*, Trondheim, Norway, Norwegian University of Science and Technology, June 2019.
- [16] G. Guidi and J. A. Suul, "Minimizing Converter Requirements of Inductive Power Transfer Systems With Constant Voltage Load and Variable Coupling Conditions," *IEEE Transactions on Industrial Electronics*, vol. 63, no. 11, pp. 6835-6844, Nov. 2016.
- [17] R. Barrera-Cardenas, O. Mo and G. Guidi, "Optimal Sizing of Battery Energy Storage Systems for Hybrid Marine Power Systems," in *2019 IEEE Electric Ship Technologies Symposium (ESTS)*, Washington, DC, USA, 2019.
- [18] K. Li, F. Wei, K. J. Tseng and B. Soong, "A Practical Lithium-Ion Battery Model for State of Energy and Voltage Responses Prediction Incorporating Temperature and Ageing Effects," *IEEE Transactions on Industrial Electronics*, vol. 65, no. 8, pp. 6696-6708, August 2018.
- [19] "HV/LV distribution transformers," Schneider Electric SAS, 2004.
- [20] H. Wu, M. Sechilariu and F. Locment, "Influence of Dynamic Efficiency in the DC Microgrid Power Balance," *Energies*, vol. 10, no. 1563, 2017.
- [21] N. P. Reddy et al, "Zero-Emission Autonomous Ferries for Urban Water Transport: Cheaper, Cleaner Alternative to Bridges and Manned Vessels," *IEEE Electrification Magazine*, vol. 7, no. 4, pp. 32-45, Dec. 2019.