

ISSN 1503-299X

# WORKING PAPER SERIES

No. 5/2005

## **CARL BARKS: A CLASSICAL ECONOMIST?**

Gunnar Bårdsen

**Department of Economics**

---

 Norwegian University of Science and Technology

N-7491 Trondheim, Norway

[www.svt.ntnu.no/iso/wp/wp.htm](http://www.svt.ntnu.no/iso/wp/wp.htm)

# Carl Barks: A classical economist?

Gunnar Bårdsen\*

15 May, 2005

Revised June 2006.

Do not cite without the author's permission.

## **Abstract**

The paper gives an introduction to the economic theories of Carl Barks, using his analysis of cyclone money as an example.

---

\*I would like to thank Paul Fisher, Håvard Hungnes, Kåre Johansen, Egil Matsen, Ragnar Nymoene, Dagfinn Rime, Bjarne Strøm and Ragnar Torvik for useful comments and suggestions. This paper builds on Bårdsen (2005).



## 1 Introduction

Carl Barks's (1951) paper analyzing cyclone money is considered a classic among aficionados of comic stories.<sup>1</sup>

---

<sup>1</sup>He finished drawing the story on 14 September 1950 and published in March 1951 in Walt Disney's Comics & Stories 126 under the title "A Financial Fable". The edition used here is from Walt Disney's Uncle Scrooge, No. 326, 2004, Gemstone Publishing.

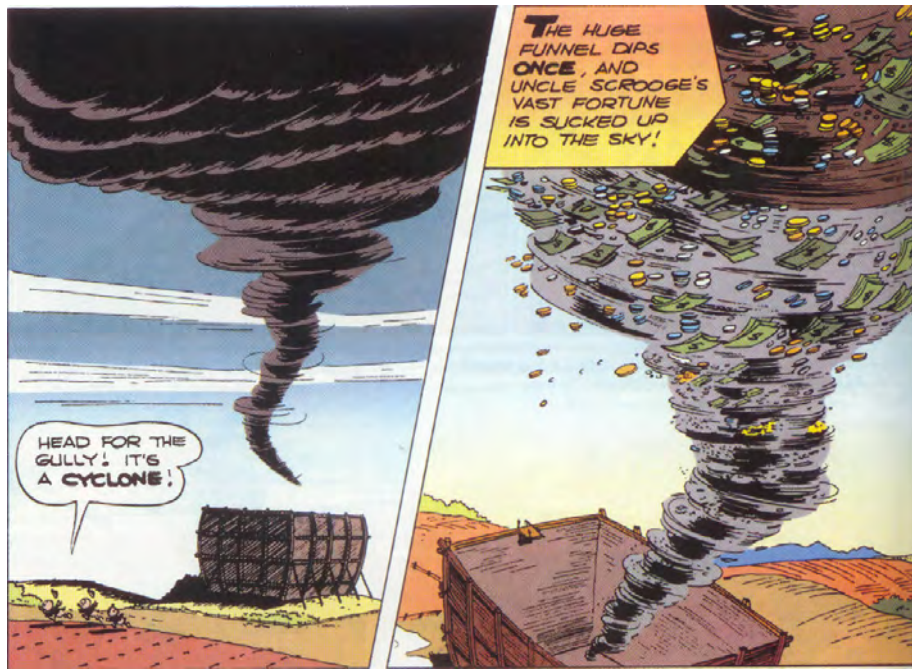

© Disney

The paper has not received the status it deserves within the economics profession, however. The reason for this is probably that the model exposition, in all its complexity and richness, exploits advanced symbolic- and linguistic techniques—not to mention advanced topology—that makes the paper a bit hard to assimilate for ordinary trained academic economists. The modest purpose of this paper is therefore to offer a translation of Barks's contribution into an exposition more suitable for economists.

## 2 Background: the standard classical model

To put Barks contribution into perspective, we first show how his background model is interpretable as the standard classical model, taught in undergraduate courses.

Barks models Ducksburg and surrounding areas as a closed economy, where real investment demand  $I$ , and real public expenditure  $G$ , is constant. In the following we therefore collect these as

$$I + G = C_O = \text{constant.}$$

Real aggregate demand  $Y$ , will therefore vary with the real expenditure  $C$  of its citizens:

$$Y = C_O + C.$$

Real expenditure depends positively on real aggregate demand, which is also real income,

$$C = C \left( \underset{+}{Y} \right),$$

where we disregard taxes, since they are kept fixed throughout the analysis.

But expenditure must be paid for by money  $M$ . The consumer price index  $P$  will of course matter for the real value of the money stock  $M$ . Demand for real money  $\frac{M^d}{P}$  is taken to be very simple in Ducksburg and is modelled

as being proportional to real income

$$\frac{M^d}{P} = k \cdot Y,$$

while aggregate money supply, except Scrooge's money crib, is given by  $\bar{M}$ . Consequently the equilibrium in the money market can be expressed in nominal terms as

$$P \cdot k \cdot Y = \bar{M}.$$

But that means that there is a negative relationship between the price level and aggregate demand:

$$P = \frac{\bar{M}}{k \cdot Y},$$

the so-called "According to Donald" (AD)-curve.

The supply of goods depends upon the labour input  $N$ :

$$Y = Y \left( \begin{matrix} N \\ + \end{matrix} \right),$$

which in the original exposition is mainly represented by the agents Donald and his cousin Gladstone. The exposition suggests that labour input has positive, but diminishing, marginal product:



© Disney

If everybody works the same amount of hours, say 8 hours every day, the aggregate supply of labor is fixed at  $\bar{N}$  and this determines employment. But the employers will not pay more in real wages  $\frac{W}{P}$  than the real value of the production of the last employed, so Donald and the others have to accept this wage.

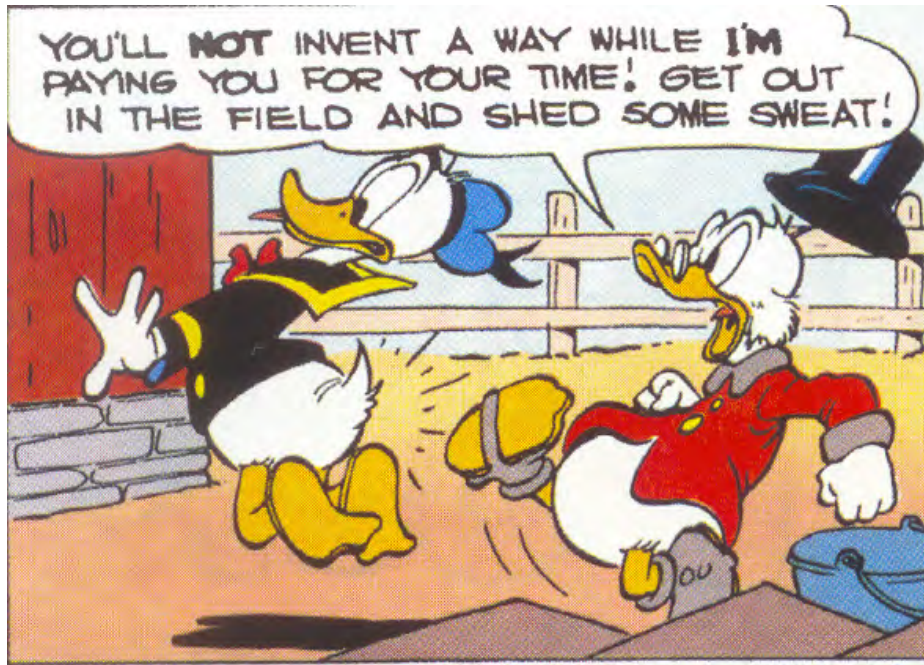

© Disney

This then determines aggregate supply  $\bar{Y} = Y(\bar{N})$  which is independent of the price level. That means that the "According to Scrooge" (AS)-curve is fixed. This concludes the modeling of the labor market. Equilibrium in the goods market is therefore

$$C_0 + C(Y) = Y(N).$$

If we now try to emulate the essence of Barks's sophisticated graphical exposition with our more simplistic graphical tools, the relationships can be approximated as shown in the figure below.<sup>2</sup>

---

<sup>2</sup>A good text-book exposition, more suitable for ordinary trained economists, can be found in Heijdra and van der Ploeg (2002), chapter 2.



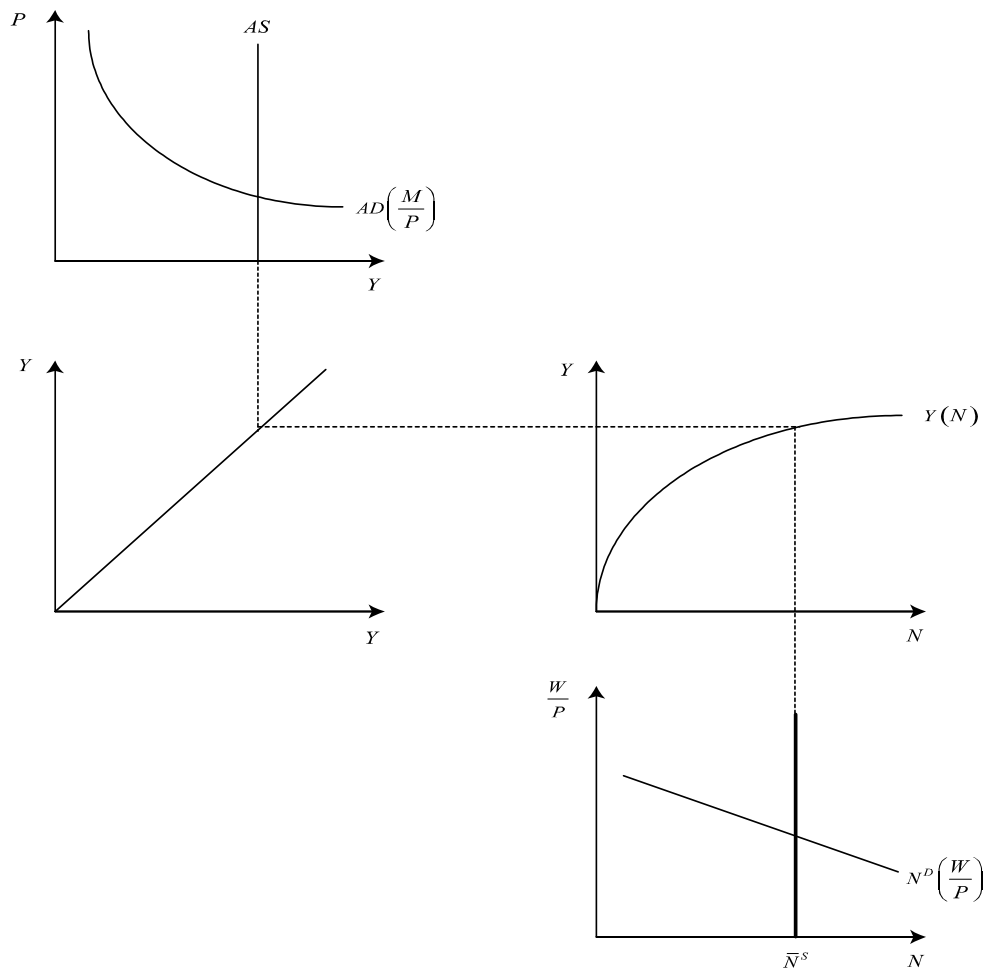

### 3 Cyclone money: the monetary shock

So far this is just the standard classical model, albeit in a more sophisticated rendering. The first contribution, however, is Barks's analysis of the effects of the monetary shock in the form of the cyclone distributing Scrooge McDuck's money equally all over Ducksburg  $\Delta M > 0$ , so everybody gets the same

amount.<sup>3</sup>

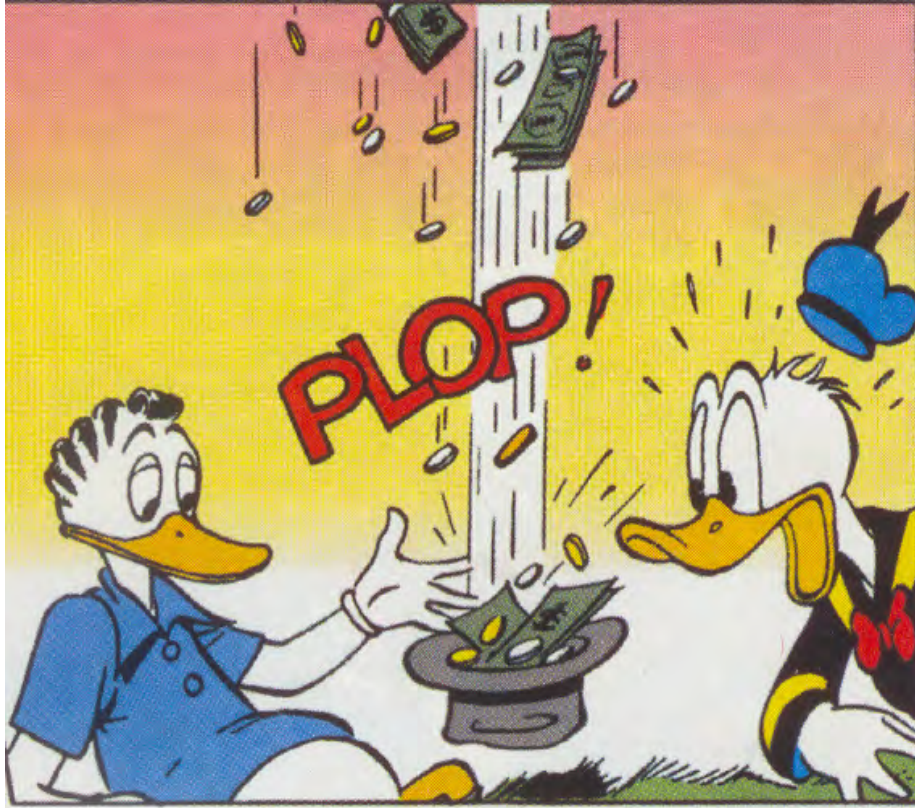

© Disney

Evidently, with more money, everyone will want to buy more goods and services. This causes aggregate demand to increase, but if supply does not change, prices have to increase to clear the market:

$$\frac{\Delta P}{\Delta M} = \frac{1}{k \cdot Y} > 0.$$

---

<sup>3</sup>See also Friedman (1969).

Put differently, when real income is fixed, real money demand is fixed—similar to classical quantity theory.

## 4 Heterogeneous agents, expectations and labor supply

One of the most impressive contributions of Barks analysis is the introduction of heterogeneous agents. This modeling is much more advanced and convincing in its complexity than we can hope to convey with our cruder tools, but we can try.

First, Barks is operating with at least three kinds of agents with different preferences and expectations generating mechanisms. One kind is represented by Scrooge McDuck.

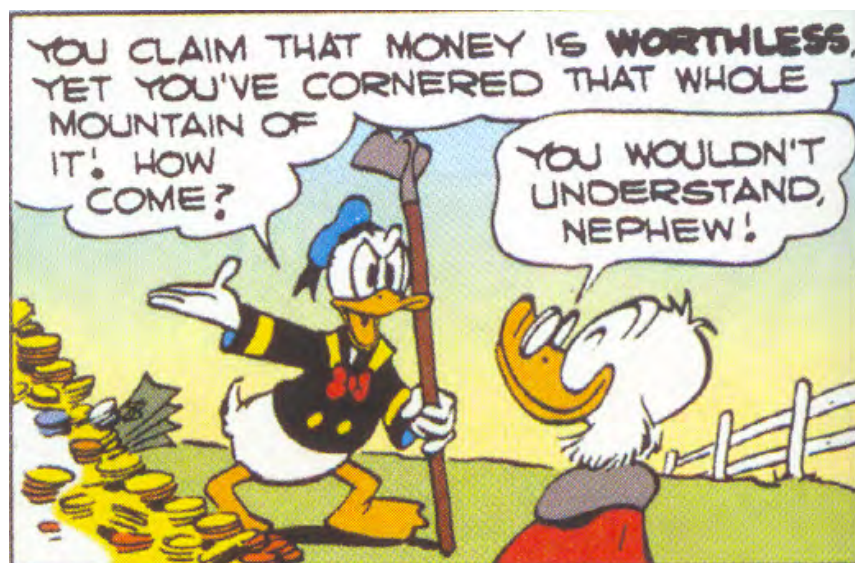

© Disney

He has money in the utility function and rational expectations<sup>4</sup>:

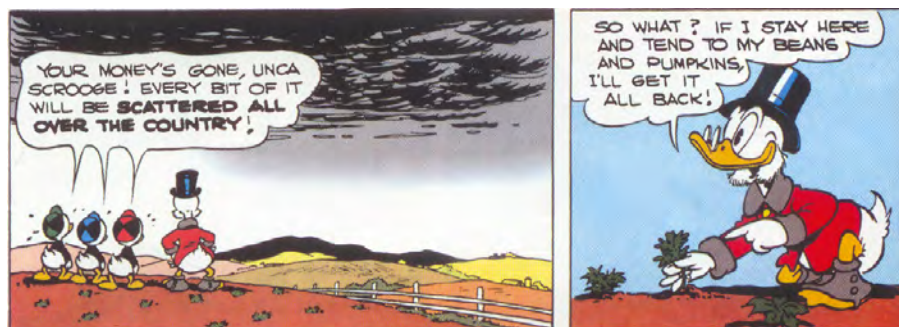

© Disney

A second kind of agents is represented by Huey, Louie and Dewey:

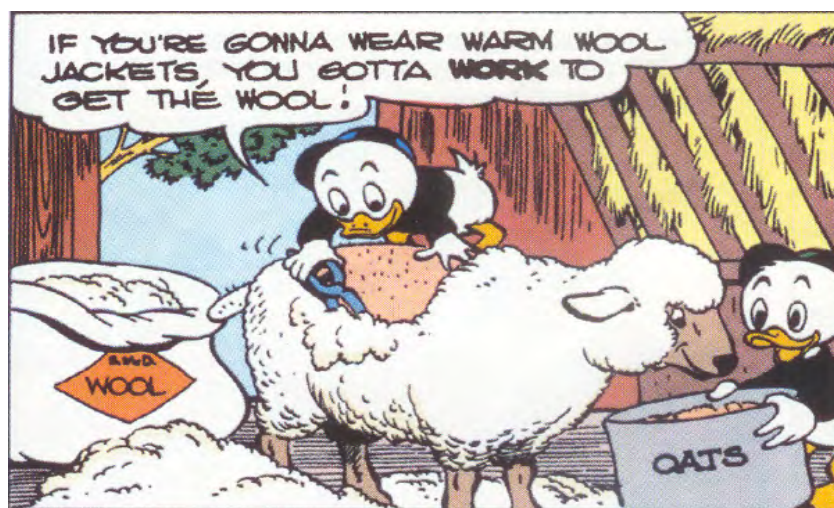

© Disney

They have labor in their utility function.<sup>5</sup>

<sup>4</sup>The usual understanding is that rational expectations was introduced in economics by Muth (1961).

<sup>5</sup>One participant at a seminar presentation labelled this kind of utility function “protestant”. Perhaps a more apt classification is “biblical”—see II. Thessalonian, 3.10: “..if any would not work, neither should he eat”.

To simplify the exposition, we can aggregate the rest of the agents into a third kind, represented by the agent Donald:

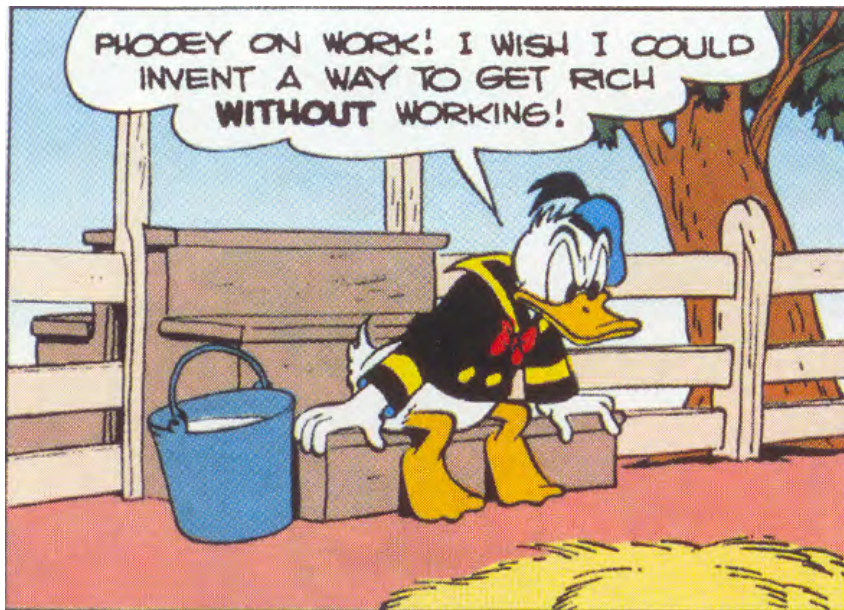

© Disney

It would be tempting to model Donald as a flibbertigibbet, but Bark's analysis is again more complex. As we shall see below, Donald has got adaptive expectations. We will interpret his utility function in a form familiar from standard economics. He wants to maximize the utility function  $U(c, l)$  which is increasing in leisure  $l$  and per capita consumption  $c$ , given the budget constraint

$$c = \frac{W}{P^e} (T - l) + \frac{m}{P^e}$$

where  $T$  is total amount of time available,  $P^e$  is the expected price level and  $m$  is per capita money supply, or labor-free income. Depending upon his

preferences for leisure and consumption, Donald will choose a combination that maximizes his utility, given his budget constraint. This is shown as the point *A* in the figure below.

So what happens if the real wage goes up? Well, the price of leisure goes up, so Donald will have an incentive to work more—this is the substitution effect. On the other hand the amount worked becomes more valuable. Donald's income goes up and makes it possible for him to work less—this is the income effect. Although it is not clear from the original paper, we will assume that the substitution effect is dominating. The new combination after an increase in the real wage is shown as point *B* in the figure below. Since most citizens of Ducksburg are like Donald, we will assume that Barks has in mind an aggregate labor supply curve that is increasing with respect to the expected real wage.

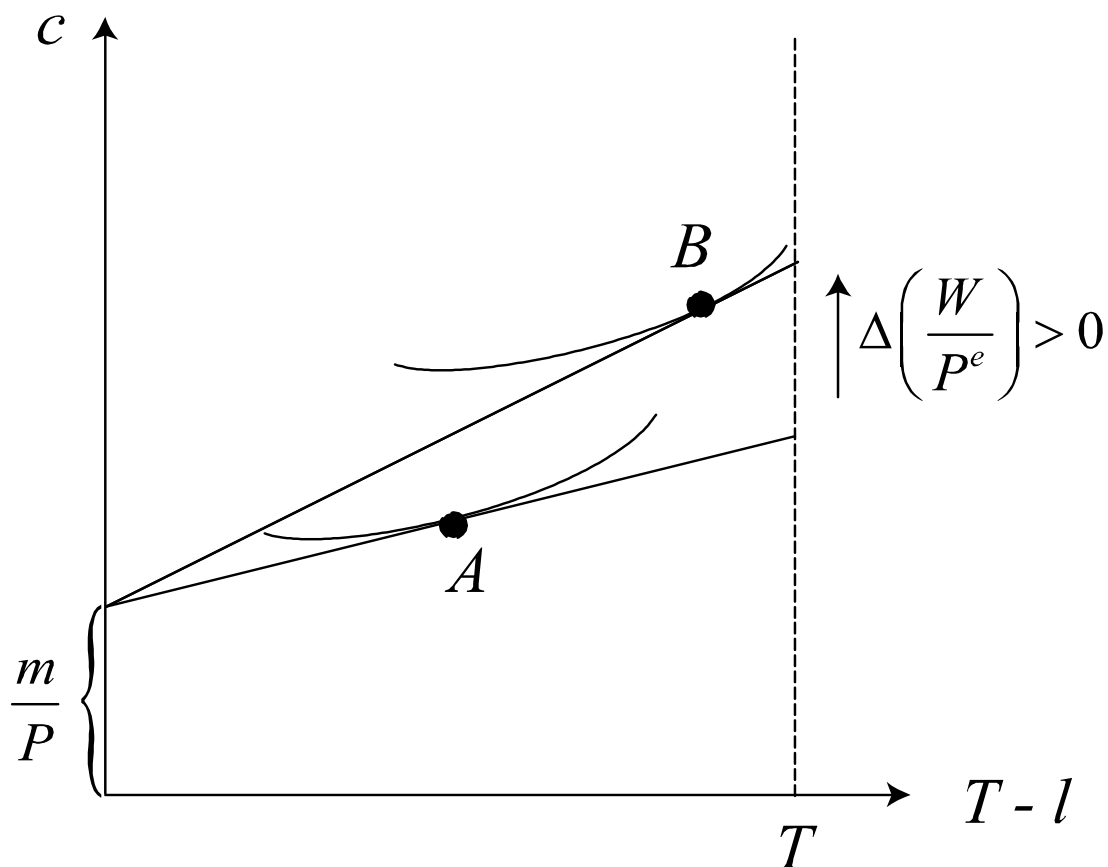

## 5 Effects on aggregate supply

So what happens if everyone gets more money? Labor free real income must increase  $\Delta\left(\frac{m}{P^e}\right) > 0$ . That means it is a pure income effect, and everyone will work less:

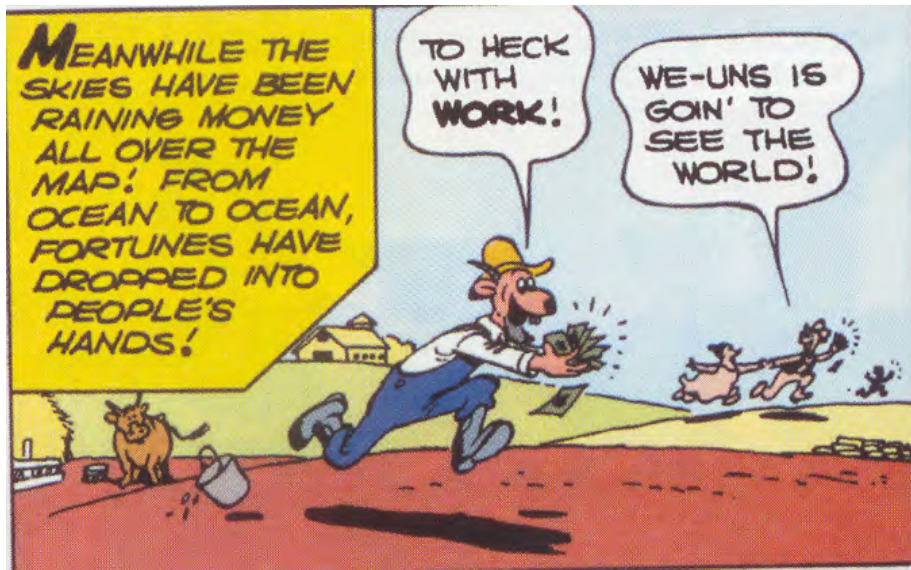

© Disney.

And when the supply of labor diminishes, given the prevailing expected real wage, production of goods and services falls:



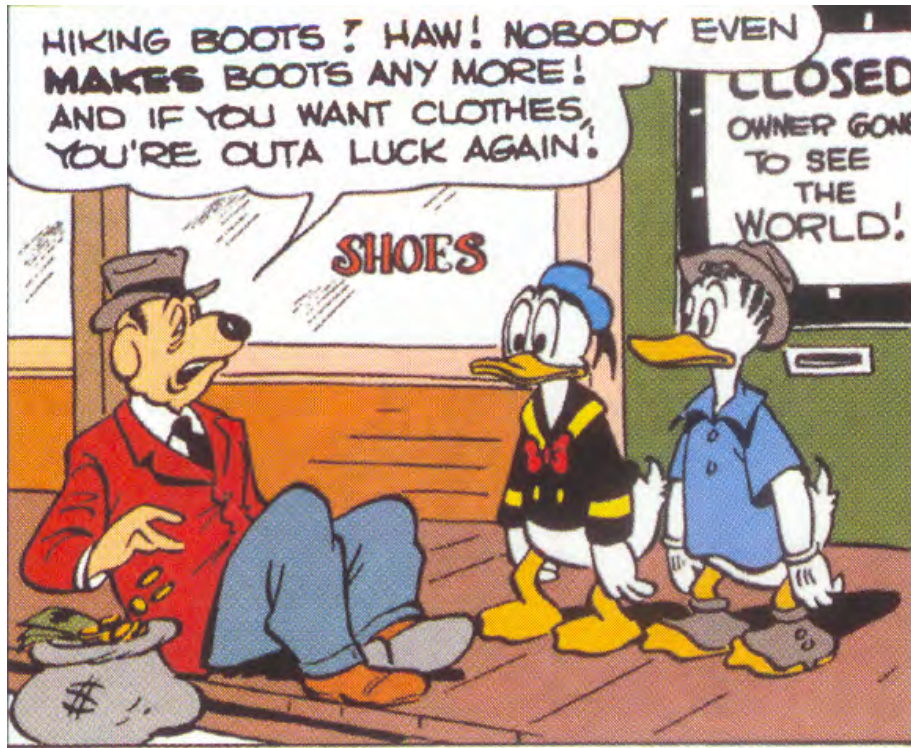

© Disney

We can try to sum up the effects in a graph:

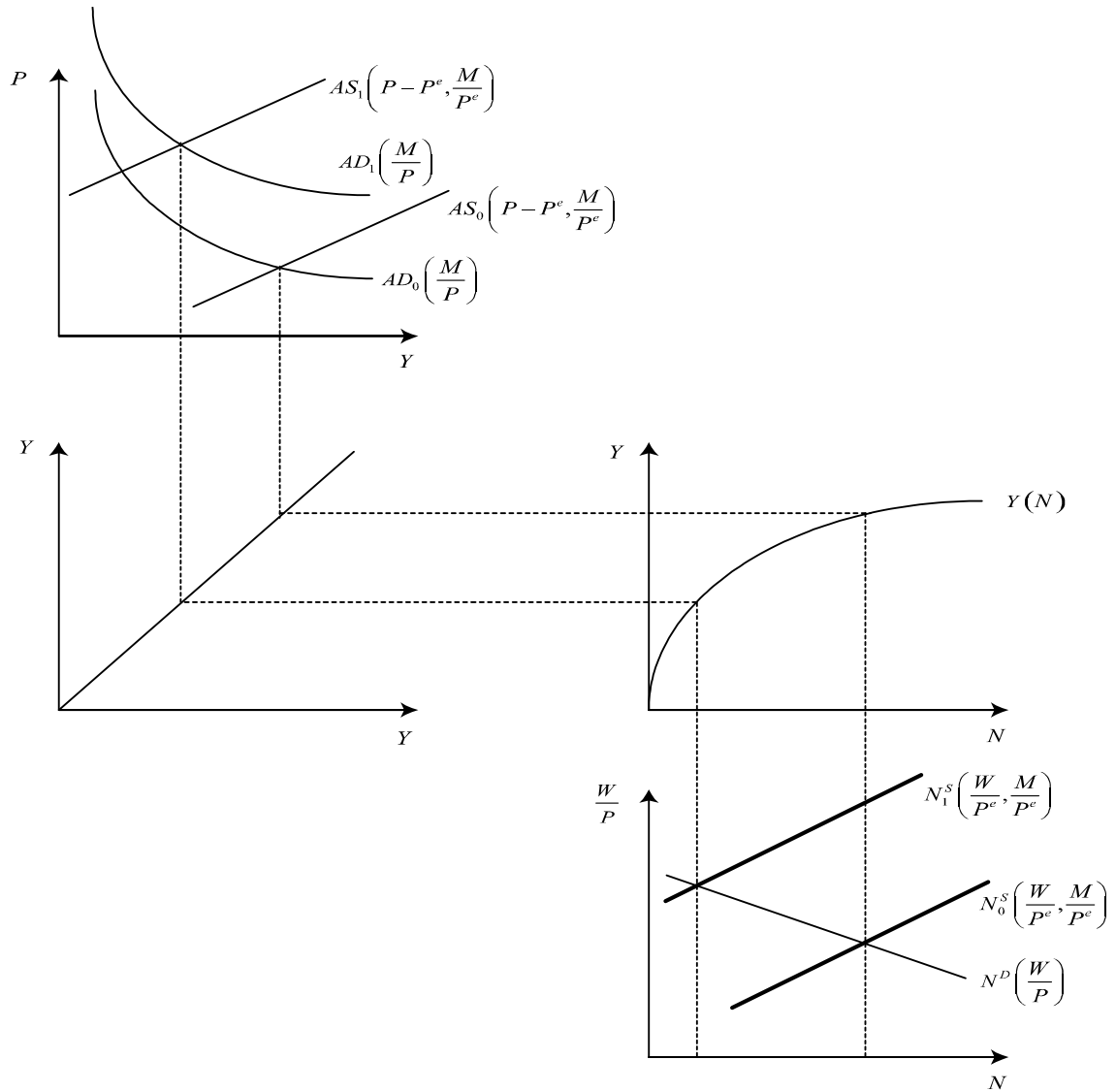

To reiterate: As Barks clearly points out, in the short run supply of goods and services will fall. At the same time demand rises, so prices will increase. So in this analysis, expansionary monetary policy will be both contractionary and inflationary in the short run. It has to be pointed out that this is an

original result. In fact, this effect is usually not present at all in this kind of model.<sup>6</sup>

## 6 Inflation and general equilibrium

The question remains whether the agents in the economy are aware of these effects, or put differently: What are their expectations about inflation? It seems as if it is only Uncle Scrooge that has any inkling about how the economy works, while for the rest the cause of changing prices are a bit of a mystery. With our tools, we can approximate this by modelling inflation expectations as being adaptive:

$$\Delta P^e = \lambda (P - P^e),$$

so expected price changes is a function of the discrepancy between the actual and the expected price level. And as the expected price level goes up, the supply of labor will increase again.

The complete effect is perhaps more succinctly expressed in Barks's notation:

---

<sup>6</sup>The closest phenomenon must be so-called “Dutch disease”, see Corden (1984), even though in those models a fixed labor supply is transferred from the trade-exposed to the sheltered part of the economy.

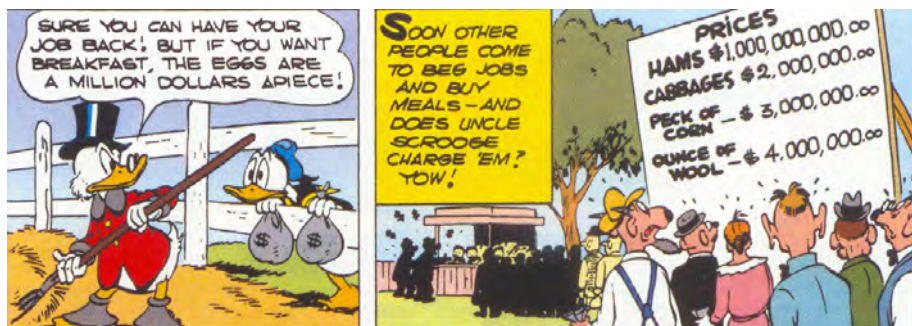

© Disney.

Summing up in our notation, the complete model is:

$$Y = AD \left( \frac{M}{P} \right)$$

$$Y = AS \left( P \underset{+}{-} P^e, \frac{M}{P^e} \right)$$

$$\Delta P^e = \lambda (P - P^e).$$

So what happens then over time? As the prices adjust, real wages and real income returns to their original values; people works as much as they used to; production returns to original levels; everything returns to normal. Once again Barks is able to present the analysis in a very concentrated way:

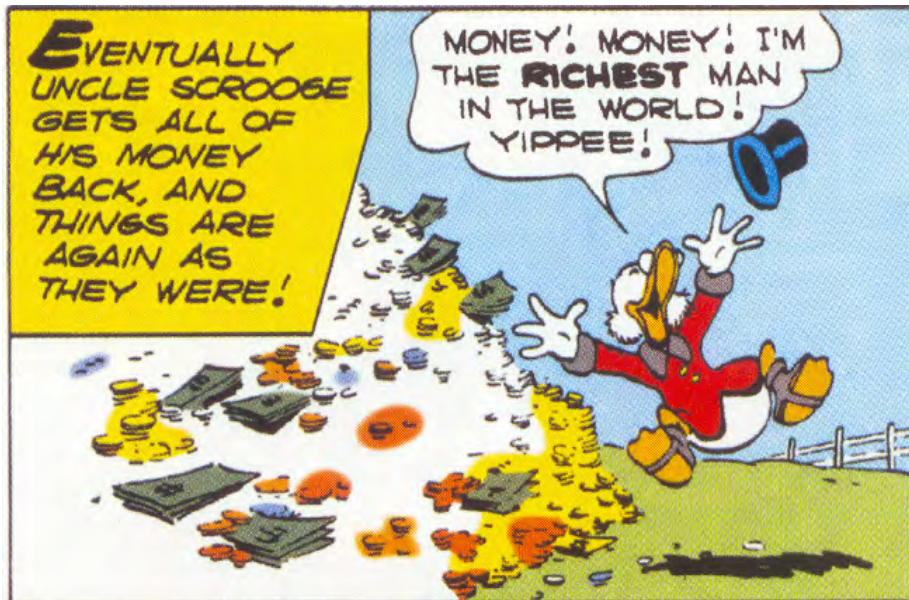

© Disney

## 7 Conclusions

Carl Barks's analysis has features we recognize from "New Classical Economics"—see Sargent and Wallace (1975). Is Barks a liberal-conservative economist, where all the focus is on the aspect of efficiency, while the distribution aspect is absent? We do not know and can only cite the conclusion of his paper:



© Disney

## References

- Bårdsen, G. (2005). Carl Barks: ein klassisk økonom? *Økonomisk Forum*, 59(1), 31–36.
- Barks, C. (1951). A financial fable. *Walt Disney's Comics & Stories*, (126).
- Corden, W. M. (1984). Booming sector and Dutch disease economics: survey and consolidation. *Oxford Economic Papers*, 36(3), 359–80.
- Friedman, M. (1969). The optimum quantity of money. In Friedman, M. (ed.), *The Optimum Quantity of Money and Other Essays*, chap. 1, 1–50. Adline Publishing Company, Chicago.
- Heijdra, B. J. and F. van der Ploeg (2002). *Foundations of Modern Macroeconomics*. Oxford University Press.
- Muth, J. F. (1961). Rational expectations and the theory of price movements. *Econometrica*, 29, 315–35.
- Sargent, T. and N. Wallace (1975). Rational expectations, the optimal monetary instrument, and the optimal money supply rule. *Journal of Political Economy*, 83, 241–54.