

29th CIRP Design 2019 (CIRP Design 2019)

Messing with boundaries - quantifying the potential loss by pre-set parameters in topology optimization

Evangelos Tyflopoulos^{a*}, Martin Steinert^a

^aDepartment of Mechanical and Industrial Engineering, NTNU, Richard Birkelandsvei 2B, Trondheim 7034, Norway

* Corresponding author. Tel.: +4747730242. E-mail address: evangelos.tyflopoulos@ntnu.no

Abstract

Additive manufacturing can increase the flexibility in the design phase of product development and that, in its turn, has changed the designer's way of thinking. The design problem has reformulated; from designs that were not possible to be constructed, due to lack of equipment and technology, to constructions that the designer could not think to design. Topology optimization and generative design are useful tools in the hands of designer that can help him/her in the pursuit of the global optimum of a construction and in the choice of an alternative design solution respectively. However, topology optimization results are always depended on the given boundary conditions and restrictions. In other words, the designer's decisions can affect the results of topology optimization and can easily lead to a local and not a global solution. In this paper, an identification and categorization of the most important parameters, that can affect the topology optimization results, were conducted. The main focus of the implemented research was on the pre-processing of topology optimization and especially on the designer's decisions. The applied topology optimization approach here was a simple compliance optimization based on the SIMP interpolation methodology (Solid Isotropic Material with Penalization) and it was executed with the use of the commercial software Tosca (Abaqus). Different alternative designs of a wall bracket were used as a case study to test the sensitivity of the optimization algorithm and quantify the potential loss.

© 2019 The Authors. Published by Elsevier B.V.

Peer-review under responsibility of the scientific committee of the CIRP Design Conference 2019

Keywords: topology optimization; SIMP; additive manufacturing; product development; design; finite element analysis

1. Introduction

The key limitation of the topology optimization approaches is their sensitivity to the given parameters by the designer [1]. These parameters, as they are presented in Table 1, can be categorized into four main parameter clusters; design constraints, supports and connections, loads, and geometric restrictions due to manufacturing constraints. First, as design constraints are considered all the dimensions that form the size and the shape of a component. Then, both the supports, connections and loads describe how the components interact with each other and with the environment. Finally, the design phase in product development should be in correlation with

the production phase. Hence, the chosen manufacturing methods can also add geometric restrictions to the design.

Table 1. The different parameters clusters given by the designer.

Clusters	Description	Examples
Design Constraints	How the designer is thinking to design the component? (geometry related constraints)	size and shape dimensions
Supports and Connections	How is the component supported? (degrees of freedom)	fixed, roller/slider, fixed hinge, bearing fixture, etc.
	How is the component mounted to the main/subassembly?	glue, weldment, screws, etc.

Loads	What loads and load cases are applied on the component?	forces, presses, moments, etc.
Geometric restrictions due to Manufacturing Constraints	How will the component be manufactured? (manufacturing derived constraints)	non-design regions ('frozen areas'), size minimums (e.g. minimum thickness, distance between two holes), symmetry (planar, cyclic), design for extrusion, etc.

In this paper, the authors quantified the potential loss, by pre-set parameters, in topology optimization. For this reason, a design model of a common wall bracket was used as case study. The wall bracket was optimized using the SIMP approach in Abaqus. Especially, four alternative designs of the bracket were tested with respect to the aforementioned categories of parameters and subsequently, their results were evaluated. This paper is focusing on the pre-processing of topology optimization, and mainly on the designer's choices. The post-processing of the topology optimization results, with the redesign and validation phases, is beyond the scope of this research.

A common goal of a designer, using topology optimization approaches, can be the redesign of a product with a significant mass reduction but always with respect to boundary conditions and restrictions, and with the best possible stiffness. This procedure is known as a minimum compliance design and it is firstly described by Bendsøe [2] under the term 'direct approach'. The direct approach is an optimization problem, which uses discrete variables. It is an element-based method which minimizes a given objective function $f(\rho, U(\rho))$ using discrete element density variables ρ_e (0: void, 1: material) and with respect to specific constraints g_i . The problem formulation, as it was originally presented by Bendsøe (1989), is the following:

$$\min_{\rho} f(\rho, U(\rho)) \text{ subject to:} \tag{1}$$

$$\sum_{e=1}^N v_e \rho_e = v^T \rho \leq V^* \tag{2}$$

$$g_i(\rho, U(\rho)) \leq g_i^*, \quad i = 1, \dots, M \tag{3}$$

$$\rho_e = \begin{cases} 0 \\ 1 \end{cases} \quad e = 1, \dots, N \tag{4}$$

$$K(\rho)U = F \tag{5}$$

where v_e and ρ_e are the element volume and density respectively, and K is the element stiffness matrix at global level. However, the use of integer numbers in the formulation can guide to the so-called 'checkerboard' problem. Rozvany [3] reformulated the problem applying continuous relative densities ($0 \leq \rho_e \leq 1$). In addition to that, he introduced the element penalization p in order to avoid the intermediate density elements. This approach is known as solid isotropic material with penalization method (SIMP). According to SIMP, the stiffness interpolation is calculated by the formula [4]:

$$E(\rho_e) = \rho_e^p E_0, \quad p \geq 1 \tag{6}$$

The continuation methods, such as SIMP, can increase the possibility to obtain a global optimal solution to the void-material problem but still the global minimum solution is not guaranteed [5]. The diagram (a) on Figure 1 illustrates the differences between the global and local optimized solutions of a cantilever beam. Furthermore, the diagram (b) highlights the feasible region of an objective function subject to two design responses (constraints). In a SIMP-based compliance approach, as objective function is selected the total strain energy (SE) of the elements, which has to be minimized with respect to a volume fraction as constraint. A small change of a parameter in the design can create a completely new objective function. Thus, the designer has to tackle with two crucial problems; to choose the best objective function in his/her case and to differentiate between the local and global optimized solution.

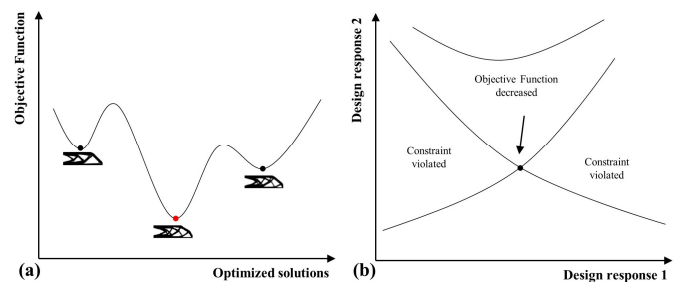

Figure 1. (a) Difference between local (black dots) and global (red dot) minima and (b) Two design responses diagram (black dot = local minimum).

2. Topology optimization of a wall bracket

This section presents a case study of a simple wall bracket in order to identify the problems of the SIMP topology optimization method in correlation with the designer's choices in the design phase of product development. Four different design alternatives were used to test the topology optimization method and compare their results (see Figure 2). These main designs have the same support (2 screws) and load F (normal distributed load, 1000N). The critical dimensions of the wall bracket are; L : length, H : height, D : distance between the holes of the supporting screws and t : thickness. The used material is an alloy steel with Young's modulus $E=2.1E11$ and Poisson's ratio $\nu=0.28$. The model was designed in SolidWorks CAD software.

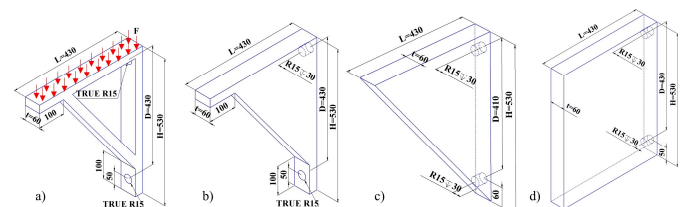

Figure 2. The four design alternatives of the wall bracket with their dimensions given in mm: a) $L=430, D=430, H=530$ and $t=60$ b) $L=430, D=430, H=530$ and $t=60$, c) $L=430, D=410, H=530$ and $t=60$, and d) $L=430, D=430, H=530$ and $t=60$.

The topology optimization of the model was implemented in Abaqus with the use of SIMP approach. First, the CAD-

models were imported in Abaqus as IGES files from SolidWorks and then, they were used for a static FEA with a mesh size equal to 10 and C3D10 (ten-node tetrahedral element) elements. Finally, the models were topologically optimized in the topology optimization modulus of the software. In total, 55 topology optimization simulations were implemented based on different design alternations. All the simulations were conducted using an Intel Core I7-7820HQ computer with 32GB RAM.

Abaqus includes two different approaches to tackle with topology optimization problems; the condition-based and the sensitivity-based. The first one is a minimum compliance design, which is based on the general topology optimization mathematical procedure and the SIMP approach [2, 6]. The sensitivity-based approach uses the method of moving asymptotes (MMA) as it was presented by Svanberg [7]. This method works with a sequence of approximate subproblems to reach the optimum solution. In the case of the compliance optimization, the algorithm begins by scaling the entire model to meet the volume constraint, and then it tries to optimize the objective function. On the other hand, the condition-based approach starts with the original design space and then slowly decreases the model's volume until the volume constraint is met. Another difference between the two approaches is that in the sensitivity-based approach, the designer has the flexibility to choose multiple design responses and constraints. Furthermore, it usually takes 50-150 design cycles (DC) to execute a sensitivity-based topology optimization instead of 15-30, in the case of condition-based approach [8].

For these reasons, the sensitivity-based approach can be more demanding in both time and computational power. In this paper, the condition-based approach was used due to its time efficiency. In addition, it was assigned a dynamically material removal so that the optimization will achieve its volume constraint in the defined design cycles. The maximum number of design cycles was chosen to be equal to 15, unless something else is stated. Thus, the main challenge of the designer in this approach is to identify the lowest volume constraint that still results in a compliant model. Different volume constraints were used in the selected examples with respect to the model's initial design space. As design space is considered the body that encompasses a space assigned the optimizer to work with. As it is shown in Table 1, the designer can possibly 'freeze' a region of the CAD-model in order to exclude it from the topology optimization module. Usually, these frozen regions constitute the support and connection regions, and the regions where the loads are applied. Another category of non-design space can be the regions that are important for the proper functioning of the system, such as the teeth of a gear [8].

2.1. Wall bracket and parameter clusters

In the following sections, some representative design alternations of the four main wall bracket designs were tested with respect to the different clusters of design parameters, as they were already described in the introduction. An overview of the simulated design examples and their results are shown in Table 2 in the appendix.

2.1.1. Wall bracket and design constraints

A common mistake at topology optimization occurs when the designer is fixated on existing designs. This does not leave enough design space for the optimization algorithm. Generally, more design space increases the simulation time, due to the higher amount of finite elements (see also section 2.4), but also increases the amount of the optimized solutions and the possibility to identify the global solution. In this example, as it is shown on Figure 3, the four design alternatives (see Figure 2) of the wall bracket led to different optimized solutions. The CAD-models were optimized using as maximum 15 design cycles and different volume fractions (VF) of their initial volume (IV) in order to reach the same volume ($V \approx 1.24E+06$ mm³) at the final design cycle in each of the cases. Furthermore, as frozen areas were defined the top side of the bracket, where the load was applied, and the two holes which represented the screw connections. The red colour, in the optimized designs, indicates the elements that contribute to the stiffness of the model while the blue colour the elements that do not and thus, can be further removed with a lower volume fraction [8]. Both 2-1-1, 3-1-1 and 4-1-1 optimized models are respectively 35.1%, 54.9% and 54.6% stiffer than the 1-1-1, with the same retained volume.

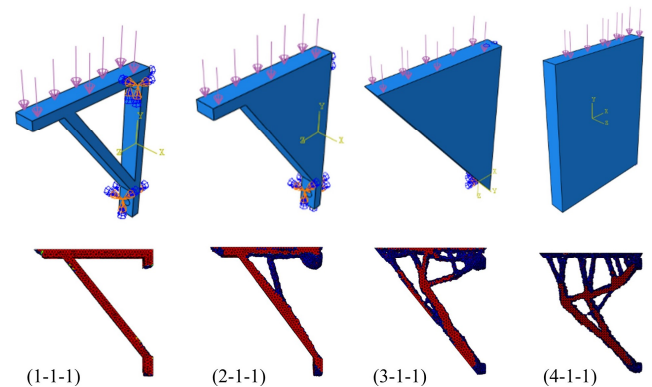

Figure 3. The optimization results of the four design alternatives using strain energy (mJ) as objective function subject to an adjustable volume fraction as constraint: 1-1-1) VF=0.7, E= 1.24E-06, 2-1-1) VF=0.334, E= 8.02E-07, 3-1-1) VF= 0.257, E=5.58E-07 and 4-1-1) VF= 0.128, E= 5.61E-07.

Other design alternations were made based on the wall bracket's thickness. In this case, new CAD-models were created in each of the four design alternatives with $\pm 20\%$ thickness variation. The presented case here is the fourth design alternative (see Figure 2), due to its highest given design space (see Figure 4). The results showed a small decrease by 4.8% of the stiffness in the subcase with the increased thickness (4-2-1) in comparison with the original design. On the other hand, there was an increase of the stiffness by 8.5% in the subcase of reduced thickness (4-2-2). It seems that smaller thickness gave better results.

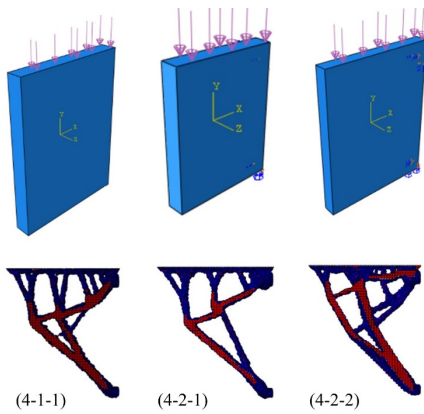

Figure 4. Sensitivity of the optimized results due to thickness changes with strain energy (mJ) as objective function with respect to volume fraction constraints: a) VF= 0.128, E= 5.61E-07, b) VF= 0.107, E= 5.88E-07 and c) VF= 0.160, E= 5.13E-07.

2.1.2. Wall bracket, and supports and connections

In the case of missing requirements in the design phase, the designer has to make his/her own simplifications and assumptions. The design subcases, presented in this section, have two alternative supports; 2-3-1) fix on the backside, and 2-3-2) use of three screws instead of two. Here are shown the results of the second design alternative (see Figure 2). As presented on Figure 5, the solutions are completely different. The subcase 2-3-2 gave the stiffest solution with 18.3% stiffness increase, than the 7.7% stiffness increase at the subcase 2-3-1, comparing to the main design. However, the process in the case of three screws is broken, as the algorithm suggested a nonconstructive solution. The designer could also interpret the result as a suggestion to shorten the length of the wall bracket. The optimized results of the first design alternative (1-3-2) guided also to material discontinuities (see Table 2). The use of the backside of the model, as an additional frozen region with a minimum thickness, could partially solve this material discontinuity problem.

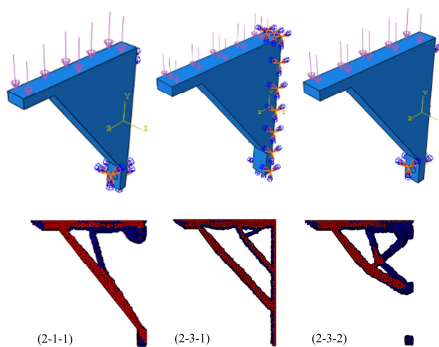

Figure 5. Sensitivity of the optimized results due to supports (fixed on backside) and connection changes (3 screws instead of 2) with strain energy (mJ) as objective function with respect to volume fraction constraints: 2-1-1) VF= 0.334, E= 8.02E-07, 2-3-1) VF= 0.331, E= 7.49E-07 and 2-3-2) VF= 0.335, E= 6.51E-07.

2.1.3. Wall bracket and loads

The topology optimization algorithm tries to locate the main load path in order to keep the critical elements, which contribute on that, and remove the other [9]. Many researchers have used the topology optimization procedure to identify the optimum load path of a structure. The identification of the optimum load path can also be used as basis in the pursuit of the global optimum [10]. In the case study of wall bracket, the authors used four different subcases: 4-4-1) + 20% of load magnitude, 4-4-2) - 20% of load magnitude, 4-4-3) load placement on the half top-face, and 4-4-4) different placement of the load (see Figure 6). As it was expected, the subcase with the lower load magnitude (4-4-2) gave the stiffest result (38.1% stiffer than the original design). On the contrary, both subcases 4-4-1, 4-4-3 and 4-4-4 gave less stiff results by 48%, 105.4% and 67.1% respectively, in comparison with the initial design case. Thus, even small changes of loads at a simulation model can lead to high stiffness fluctuations of the structure.

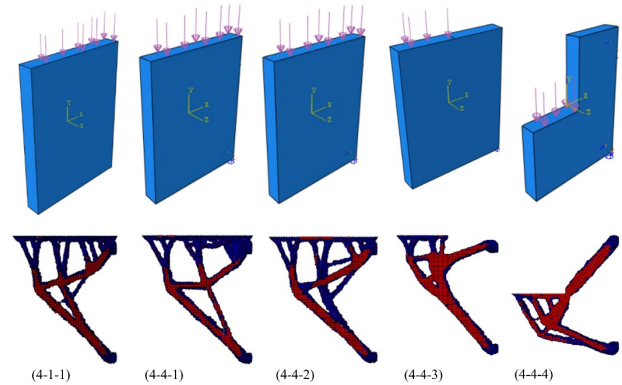

Figure 6. Sensitivity of the optimized results due to changes of load magnitude and positioning with strain energy (mJ) as objective function and adjustable volume fraction constraint: 4-1-1) VF=0.128, E= 5.61E-07, 4-4-1) VF=0.128, E= 8.30E-07, 4-4-2) VF=0.128, E= 3.47E-07, 4-4-3) VF=0.128, E= 1.15E-06 and 4-4-4) VF=0.171, E= 9.37E-07.

2.1.4. Wall bracket and geometric restrictions due to manufacturing constraints

Many design alternations fall within this category of parameters, from geometric restrictions (e.g. minimum radius, fixed distance between holes) to a design based on a manufacturing procedure (e.g. demold control, design for extrusion). In this section, three design examples are presented based on the fourth design alternative (see Figure 2). The planar symmetry and the distance between the two holes are the changing parameters. In all the four design alternatives, a vertical planar symmetry was used. Especially in the subcases 4-5-1 and 4-5-2 no symmetry and both vertical and horizontal symmetry were used respectively. Finally, the distance of the holes was reduced by 20% in the last subcase (4-5-3), adjusting the placement of the top hole. The subcase 4-5-1 gave the stiffest result by 5.7% compared to the original design. Both subcases 4-5-1 and 4-5-3 gave less stiff results by 78.8% and 28.3% respectively (see Figure 7).

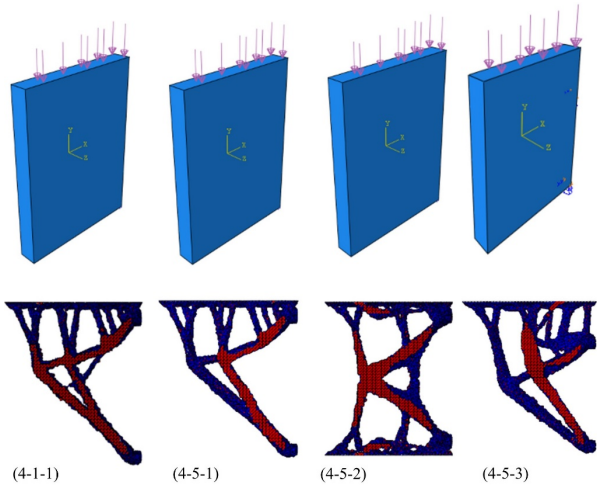

Figure 7. Sensitivity of the optimized results due to manufacturing constraints with strain energy (mJ) as objective function and same volume fraction constraint, VF= 0.128: 4-1-1) E= 5.61E-07, 4-5-1) E= 5.28E-07, 4-5-2) E= 1.00E-06 and 4-5-3) E= 7.19E-07.

2.2. Topology optimization and objective function

The diagrams on Figure 8 show the analytical correlation between the objective function (strain energy) and the topology optimization constrain (volume fraction) during the design cycles. It is reasonable that a change in the design space could result to a different objective function but even small changes, such in subcase 4-4-1 (+ 20% of load magnitude) and 4-5-3 (- 20% change of holes distance), led to new objective functions and thus, to different local optima. The local optimum in the wall bracket case study, with the use of compliance topology optimization, was the design with the lowest stain energy for the lowest possible volume fraction.

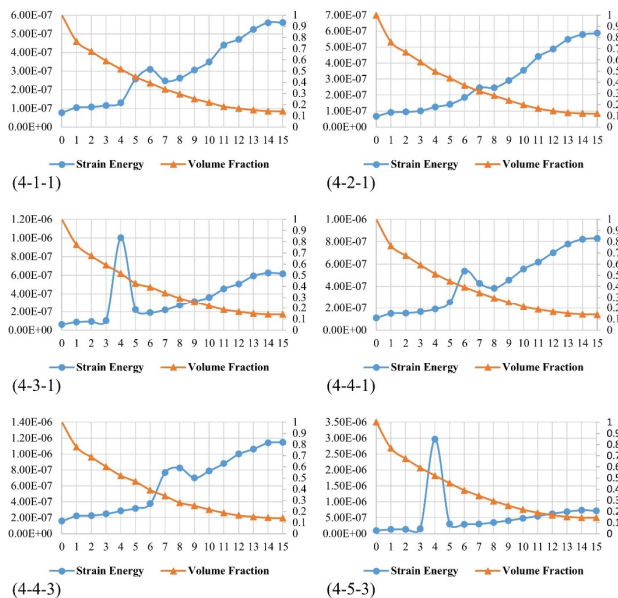

Figure 8. The optimized results during 15 design cycles of six subcases of the fourth wall bracket alternative represented by two design responses diagrams (strain energy in mJ, and volume fraction): 4-4-1) The fourth design alternative, 4-2-1) +20% thickness, 4-3-1) Fixed on back side, 4-4-1) +20% of load, 4-4-3) Load placement on the half top-face and 4-5-3) -20% of holes distance.

2.3. Wall bracket and design cycles

All the topology optimization simulations were executed with 15 maximum design cycles. In each of the design cycles, the algorithm tries to minimize the maximum value of the given objective function. The objective function in a compliance topology optimization is the sum of the finite elements' strain energy. This is implemented with respect to constrains, which in the case of compliance optimization is a volume fraction or a specified volume value. According to condition-based approach in Abaqus, it is recommended to use 15-30 design cycles [8]. The following diagrams present the strain energy results of all the four alternative designs simulated with 15, 20, 30, 40 and 50 design cycles and the correlation between the amount of the design cycles and the execution time. It is difficult to identify the ideal number of the used design cycles but, as it is shown in the diagram (a) in Figure 9, there were small changes in strain energy results in all the four design alternatives of the wall bracket. It seems that the results had been converged from the beginning using only 15 design cycles. That is very important because, as it is presented in the diagram (b) on Figure 9, there is a proportional correlation between the number of defined design cycles and the execution time of the topology optimization algorithm. Thus, the choice of the right number of the design cycles by the design can lead to a certain time saving. In addition, the third and fourth design alternatives, as it is shown in the diagram (a), gave the best and almost identical results with respect to model's stiffness. Hence, there is also convergence in algorithm's results after a certain increase of the design space.

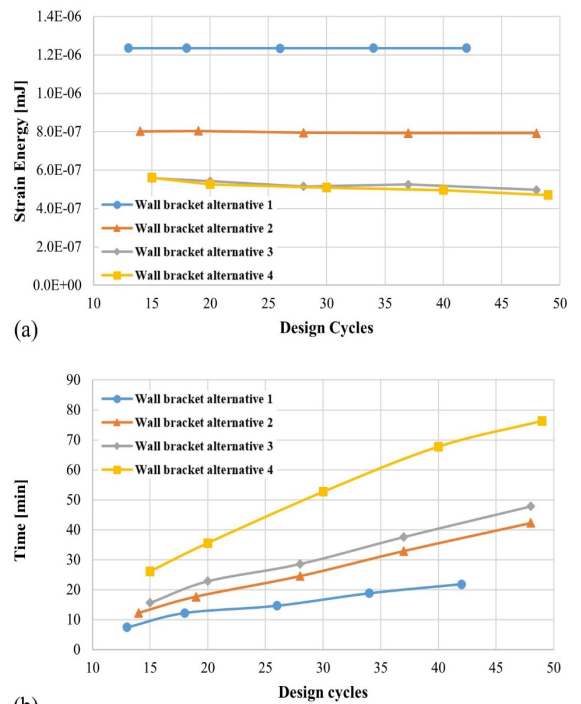

Figure 9. a) Design cycles-Strain energy diagram of the four design alternatives, b) Design cycles-Time diagram of the four design alternatives.

2.4. Topology optimization and time

The execution time of the implemented simulations varied from 6.4 to 40.2 minutes. There was a clear correlation between the given design space, in amount of finite elements, and the execution time (see Figure 10). In addition, if in this time are also considered both the design and the post-processing time of the optimized designs, with the redesign and validation, it is clear that topology optimization is time demanding. The parameters that affect the number of finite elements are the design space, the frozen areas and the mesh quality with possible mesh-controls in critical regions (e.g. holes). In other words, a small mistake, a wrong assumption or a small change of the initial design by the designer can be interpreted as loss of valuable time.

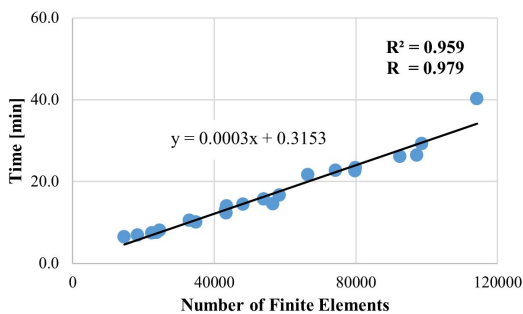

Figure 10. Finite elements- time diagram of all topology optimization simulations of the wall bracket.

3. Conclusion

This paper identified the effect of the topology optimization results in relation to the designer's choices in the pre-processing phase. The design parameters were classified in four categories based on the different questions that the designer had to answer in the design phase. What is the size and the shape of a component? How will it be supported and connected to the construction? How will it be manufactured? These are some of the crucial questions that have to be answered by the designer. Thus, the key limitation of the topology optimized results are not only the different answers to these questions but also the questions themselves. In addition to the different type of supports, the connections and the manufacturing constrains, other designer's dilemmas that can affect the results, are the size of the design space, the mesh quality and the choice of the frozen areas. All these can affect the executing time and the results. Moreover, either under-constrained or over-constrained models can guide to fail optimized results.

As it was found in the case study of wall bracket, the optimization algorithm was searching for the closest local optimum and led to biased results. The initial design together with the taken by the designer path resulted to different optimized design solutions. The main reason is that small changes in the design changed the objective function in the topology optimization. The four presented parameter clusters helped the designer to answer crucial questions during the design phase and frame the design problem. However, there are often constrains that cannot be used in a software. For

example, in the presented subcases 1-3-2 and 2-3-2 the topology optimization procedure guided the designer to not feasible constructions. Therefore, the designer needs to spend more time in order to modify them.

Finally, it is clear that the path from the topology optimized and CAD results is broken. It is very important for the designer to understand that the optimized solutions are not the best solutions but some suggestions that could be used as a base in the post-processing phase with redesign and validation using FEA. Thus, the optimized solutions need to be interpreted in terms of cost, time and manufacturing feasibility.

4. Future research

In this paper, the different geometries of the wall bracket were optimized using a compliance optimization based on the SIMP interpolation methodology under the name 'condition-based approach' in Abaqus. An alternative option in Abaqus could be the method of Moving Asymptotes (MMA). This approach is more demanding, in both time and computational power, but can increase the chance of identifying the global optimum. In addition, it could be interesting to compare the optimized results taken by different topology optimization approaches, such as the Evolutionary Structural Optimization (ESO) and the Level Set.

Furthermore, an experimental work could validate and support the simulation results of this paper.

















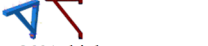



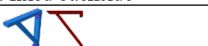
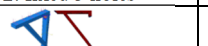
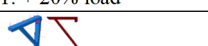
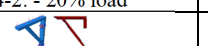





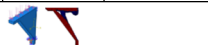

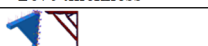
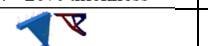
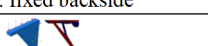
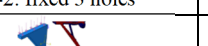
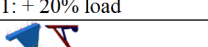
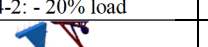







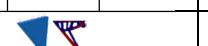
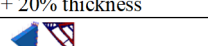
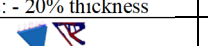
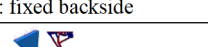
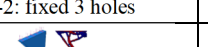
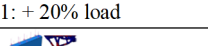
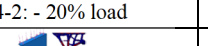

Finally, topology optimization is a hard and time demanding procedure, which is also vulnerable to designer errors and choices. Thus, a further research regarding a more automatic and effective topology optimization procedure is needed.

References

- [1] Tyflopoulos E, Flem DT, Steinert M, Olsen A. State of the art of generative design and topology optimization and potential research needs. DS 91: Proceedings of NordDesign 2018, Linköping, Sweden, 14th - 17th August 2018 DESIGN IN THE ERA OF DIGITALIZATION: The Design Society; 2018. p. 15.
- [2] Bendsoe MP. Optimal shape design as a material distribution problem. *Structural optimization*. 1989;1(4):193-202.
- [3] Rozvany GIN. Optimal Layout Theory - Analytical Solutions for Elastic Structures with Several Deflection Constraints and Load Conditions. *Structural Optimization*. 1992;4(3-4):247-9.
- [4] Bendsoe MP, Sigmund O. Material interpolation schemes in topology optimization. 1999;69(9-10):635-54.
- [5] Stolpe M, Svanberg K. An alternative interpolation scheme for minimum compliance topology optimization. *Structural and Multidisciplinary Optimization*. 2001;22(2):116-24.
- [6] Rozvany GI, Zhou M, Birker T. Generalized shape optimization without homogenization. 1992;4(3-4):250-2.
- [7] Svanberg K. The Method of Moving Asymptotes - a New Method for Structural Optimization. *International Journal for Numerical Methods in Engineering*. 1987;24(2):359-73.
- [8] Dassault Systèmes D. Abaqus analysis user's guide. Technical Report Abaqus 6.14 Documentation, Simulia Corp; 2016.
- [9] Fiedler K, Rolfe B, Asgari A, de Souza T. A systems approach to shape and topology optimisation of mechanical structures. 2012;125:145-54.
- [10] Lu K-J, Kota S. An effective method of synthesizing compliant adaptive structures using load path representation. 2005;16(4):307-17.

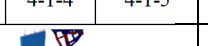
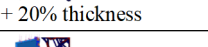
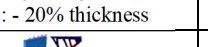
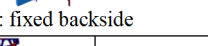
Appendix A

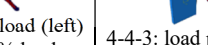
Table 2. An overview of the optimized results of the wall bracket

Case	Subcase	Original and Optimized designs					IV (mm ³)	DC	SE (mJ)	VF	
Wall bracket alternative 1	1-1-1							2475339	13	1.24E-06	0.706
	1-1-2								18	1.24E-06	0.704
	1-1-3								26	1.23E-06	0.706
	1-1-4								34	1.24E-06	0.705
	1-1-5								42	1.24E-06	0.705
	1-2-1										
	1-2-2						1994680	13	2.15E-06	0.707	
	1-3-1						2517750	13	9.89E-07	0.706	
	1-3-2						2454133	13	1.24E-06	0.706	
	1-4-1						2475339	13	1.78E-06	0.706	
1-4-2						14		7.90E-07	0.705		
1-5-1						2475339	14	1.24E-06	0.704		
1-5-2							14	3.56E-06	0.704		
Wall bracket alternative 2	2-1-1							5231589	14	8.02E-07	0.345
	2-1-2								19	8.04E-07	0.344
	2-1-3								28	7.95E-07	0.345
	2-1-4								37	7.93E-07	0.345
	2-1-5								48	7.93E-07	0.344
	2-2-1										
	2-2-2						4176789	15	8.48E-07	428	
	2-3-1						5274000	15	7.49E-07	0.343	
	2-3-2						5210383	15	6.51E-07	0.347	
	2-4-1						5231589	15	1.16E-06	0.344	
2-4-2						14		5.15E-07	0.345		
2-5-1						5231589	14	8.00E-07	0.345		
2-5-2							15	1.32E-06	0.347		
Wall bracket alternative 3	3-1-1							6794589	15	5.58E-07	0.272
	3-1-2								20	5.42E-07	0.270
	3-1-3								28	5.16E-07	0.269
	3-1-4								37	5.25E-07	0.269
	3-1-5								48	4.97E-07	0.269
	3-2-1										
	3-2-2						5427189	15	5.21E-07	0.333	
	3-3-1						6837000	15	6.08E-07	0.269	
	3-3-2						6773383	15	5.50E-07	0.269	
	3-4-1						6794589	15	8.15E-07	0.270	
3-4-2						15		3.59E-07	0.270		
3-5-1						6794589	14	5.66E-07	0.269		
3-5-2							15	7.43E-07	0.271		
Wall bracket alternative 4	4-1-1							13631588	15	5.61E-07	0.141
	4-1-2								20	5.26E-07	0.143
	4-1-3								30	5.09E-07	0.142
	4-1-4								40	4.96E-07	0.141
	4-1-5								49	4.71E-07	0.141
	4-2-1										
	4-2-2						10896789	15	5.13E-07	0.173	
	4-3-1						13674000	15	6.18E-07	0.142	
	4-3-2						13610383	15	4.92E-07	0.142	
	4-4-1							13631589	15	8.30E-07	0.141
4-4-2	4-4-1: +20% load (left) 4-4-2: -20% load (right)						13631589	15	3.47E-07	0.143	
4-4-3							13631589	15	1.15E-06	0.141	
4-4-4							10213089	15	9.37E-07	0.185	
4-5-1							13631589	15	5.28E-07	0.143	
4-5-2								15	1.00E-06	0.141	
4-5-3								15	7.19E-07	0.143	