



Norwegian University of  
Science and Technology

# Force measurement using a capacitive sensor and a compressible material

**Sivert Stubsjøen**

Master of Science in Electronics

Submission date: June 2018

Supervisor: Snorre Aunet, IES

Norwegian University of Science and Technology  
Department of Electronic Systems



---

## MASTER ASSIGNMENT

**Candidate name:**

Sivert Stubsjøen

**Assignment title:**

Force measurement using a capacitive sensor and a compressible material

**Assignment text:**

Capacitive sensors can be used to accurately measure distance. The idea is to use a compressible material on front of a capacitive sensor to measure the force applied to the sensor. The capacitive sensor is strongly non-linear, and an data model must be made to find the force based on the sensor reading.

The assignment is to:

- Study materials and find suitable compressible material
- Make practical measurements characterizing the capacitive sensor and the compressible material
- Make a data model to estimate force based on sensor readings
- Design calibration scheme for sensor
- Implement sensor solution if time

**Assignment proposer:**

Øystein Moldsvor - Disruptive Technologies AS

**Supervisor:**

Snorre Aunet

---

---

---

---

# Abstract

Disruptive Technologies are developing sensor solutions for the Internet of Things. Their current sensors can measure touch, temperature, and proximity. To expand the area of applications their current sensors cover, new sensor solutions are examined. The one studied in this thesis is a capacitive sensor measuring force. The idea is to place a compressible material on the front of Disruptive Technologies capacitive proximity sensor and use it to measure force. A compression of the material would lead to an increased capacitance measured.

This thesis covers the work of finding suitable materials and the practical measurements done to characterize the capacitive sensor and the compressible material. Testing was done at two different materials that had properties useful for the intended application. These tests revealed that neither of the materials was optimal for a solution as described above. For different series of measurements, the values measured by the sensor varied for the same applied load. This made the work of creating a good fitting data model difficult. The proposed models could not predict with high probability the values measured by the sensor for the various applied loads.

This led to the conclusion that either the materials or the chosen sensor solution was not the optimal one for measuring force. As a result of this, two other force sensing methods using the same sensor is presented that can be further investigated in future work.



---

# Sammendrag

Disruptive Technologies er et selskap som utvikler sensorløsninger for Tingenes internett. Deres nåværende sensorer kan måle berøring, temperatur, og nærhet. For å utvide bruksområdene disse sensorene dekker blir nye sensorløsninger utforsket. Den løsningen som er studert i denne hovedoppgaven er en kapasitiv sensor som måler kraft. Ideen er å plassere et komprimerbart materiale på Disruptive Technologies kapasitive nærhetssensor. En kompresjon av materialet vil da lede til at en økt kapasitans blir målt.

Denne hovedoppgaven dekker arbeidet som er gjort for finne passende materialer og de praktiske målingene som ble gjort for å karakterisere den kapasitive sensoren og materialet. Testing ble utført på to ulike materialer som hadde egenskaper som kunne være nyttig for den tiltenkte sensoren. Disse testene avslørte at ingen av de to materialene var optimale for en slik løsning som er beskrevet over. For ulike serier med målinger så varierte verdiene som sensoren målte for den samme påtrykte kraften. Dette gjorde arbeidet med å finne en datamodell som passet godt til målingene vanskelig. De modellene som ble foreslått kunne ikke med stor sannsynlighet forutsi hvilke verdier sensoren målte for kraften som ble påtrykt.

Dette førte til en konklusjon som sa at enten så var materialene eller den valgte sensorløsningen ikke den optimale for å måle kraft. Som et resultat av dette ble to andre måter å måle kraft presentert. Den samme sensoren blir brukt og dette er noe som kan bli undersøkt i fremtidig arbeid.





---

# Preface

I would like to thank my supervisor Snorre Aunet and Øystein Moldsvor at Disruptive Technologies for their help and useful advices.



# Table of Contents

Abstract	i
Sammendrag	iii
Preface	v
Table of Contents	viii
List of Tables	ix
List of Figures	x
1 Introduction	1
1.1 Motivation . . . . .	1
1.2 Problem Description . . . . .	1
1.3 Goal of the thesis . . . . .	2
1.4 Main contributions . . . . .	2
1.5 Thesis outline . . . . .	3
2 Background theory	4
2.1 Force measurement . . . . .	4
2.2 Capacitive sensing . . . . .	5
2.2.1 Sensor configuration . . . . .	6
2.3 Materials . . . . .	7
2.3.1 Material selection . . . . .	8
2.4 Fitting models to measured data . . . . .	8
3 Other work	10
3.1 Weight measurement using an inductive sensor . . . . .	10
3.2 Mass measuring using a capacitive system . . . . .	11
3.3 Dielectric elastomers . . . . .	11
4 Method of approach	13
4.1 The capacitive sensor . . . . .	13
4.2 The materials . . . . .	14
4.3 The testing . . . . .	15
4.4 The processing of data . . . . .	17
5 Results	18

---

5.1	Initial tests . . . . .	18
5.2	Testing with weights . . . . .	22
5.2.1	R10480S . . . . .	22
5.2.2	R10480M . . . . .	26
5.3	Summary of test results . . . . .	29
6	Discussion . . . . .	30
6.1	Choice of material . . . . .	30
6.2	The test results . . . . .	31
6.2.1	The initial testing . . . . .	31
6.2.2	The testing with weights . . . . .	32
6.2.3	The sensor solutions . . . . .	33
7	Conclusion . . . . .	35
7.1	Further work . . . . .	36
	Bibliography . . . . .	36

# List of Tables

2.1	Material properties . . . . .	7
4.1	Ordered materials . . . . .	14
4.2	The plates weight . . . . .	16
5.1	Average sensor values for R10480S . . . . .	19
5.2	Average sensor values for R10480M . . . . .	20
5.3	Coefficients for equation 5.1 . . . . .	23
5.4	Coefficients for equation 5.2 . . . . .	24
5.5	Coefficients for the the fitted curve. . . . .	27
5.6	Coefficients for the the fitted curve. . . . .	28

# List of Figures

2.1	Illustrations of capacitive sensors. . . . .	6
2.2	Block diagram of sensor. . . . .	6
2.3	Ashby plot for Young's modulus vs density [26]. . . . .	8
2.4	Illustration of scatter plot. . . . .	9
3.1	. . . . .	10
3.2	. . . . .	11
3.3	Illustration of the flexible capacitive sensor [6]. . . . .	12
3.4	. . . . .	12
4.1	Illustration of the capacitive sensor. . . . .	13
4.2	Illustration of the sensors connection. . . . .	13
4.3	Illustration of material mounted to the sensor. . . . .	15
4.4	. . . . .	16
4.5	Sketch of test stand. . . . .	16
4.6	Illustration of Grafana dashboard. . . . .	17
5.1	Plot of the results from testing the R10480S using the force gauge. . . . .	19
5.2	Plot of the results from testing the R10480M using the force gauge. . . . .	20
5.3	Plot of the results from testing the R10480S using the force gauge and spring scale. . . . .	21
5.4	Plot of the results from testing the R10480S using weights. . . . .	23
5.5	Residual plot for the fit in figure 5.4. . . . .	23
5.6	Plot of the results from testing the R10480S using the weights. . . . .	24
5.7	Residual plot for the fit in figure 5.6. . . . .	25
5.8	Plot of the results from testing the R10480S under a constant load. . . . .	25
5.9	Plot of the results from removing the constant load. . . . .	26
5.10	Plot of the results from testing the R10480M using the weights. . . . .	26
5.11	Residual plot for the fit in figure 5.10. . . . .	27
5.12	Plot of the results from testing the R10480M using the weights. . . . .	27
5.13	Residual plot for the fit in figure 5.12. . . . .	28
5.14	Plot of the results from testing the R10480M under a constant load. . . . .	28
6.1	Sketches of alternative solutions . . . . .	34

# Chapter 1

## Introduction

### 1.1 Motivation

The Internet of Things is getting bigger day by day. Everyday devices such as toys, door locks, and thermostats are becoming *smart* and connected to the internet. The term Internet of Things also covers sensors. A sensor can measure, evaluate and gather data. By connecting a significant number of sensors creating a network, the information they collect can be used in numerous applications. The massive amount of data that such a network will gather will demand an infrastructure that efficiently stores and process it.

One company developing a complete sensor solution for the Internet of Things are Disruptive Technologies. The key features of their sensors are that they are wireless, have a small size and up to 15 years of battery life. The current sensors Disruptive Technology offer can sense temperature, proximity, and touch. Disruptive Technologies wants to examine the possibilities for developing their current sensors to cover new areas of applications and to add new types of sensors to their sensor platform.

One of these new types is a sensor measuring the force applied to it. Disruptive Technologies capacitive sensor can be used to measure distance accurately. If their current sensor can be developed further, it is a way to keep its key features and simultaneously add an entirely new range of use to it. A sensor measuring force can, for instance, monitor various loads or weigh an object by measuring the pressure applied to the sensor.

### 1.2 Problem Description

Capacitive sensors can be used to measure distance accurately. The idea is to use a compressible material on the front of a capacitive proximity sensor to measure the force applied to it. An applied force will compress the material, change the spacing between the sensor and the object compressing the material, and thus change the capacitance measured by the sensor. The capacitive sensor used is strongly non-linear, and a data model must be made to find the force based on the sensor reading. It is necessary to test such a solution by compressing the material with known forces to create a data model. In addition to this, the data model itself has to be evaluated to see how well it fits the measured data from the sensor.

## 1.3 Goal of the thesis

The sensor used in this thesis is specified to be Disruptive Technologies capacitive sensor. As this is stated in advance, the primary goals are as listed below.

- Find a suitable compressible material.
- Make practical measurements characterizing the capacitive sensor and the compressible material.
- Make a data model to estimate force based on sensor readings.
- Evaluate sensor solution.

The first goal in the list would be achieved by first explore which material properties that would be important for a solution as described in section 1.2. The second step to achieve this goal is to find materials that hold these properties. The second goal in the list would be achieved by testing the sensor solution. A data model can be created using the measurements collected while testing.

## 1.4 Main contributions

The main contributions of this thesis are

- The study of necessary material properties and selection of materials.
- The results of the practical measurements characterizing the sensor and materials.
- The data models for estimating the applied force to the sensor, and the evaluation of the sensor solution in general.



## 1.5 Thesis outline

The rest of the thesis is organized as follows

**Chapter 2 - Background theory:** This chapter presents theory and information useful for understanding the rest of this thesis. It gives an introduction to force measurement, capacitive proximity sensors, materials, and data modeling.

**Chapter 3 - Other work:** A presentation of other work relevant for this thesis is found in this chapter. It will cover both similar approaches and other relevant methods.

**Chapter 4 - Method of approach:** In this chapter both the capacitive sensor and the materials used in this thesis are presented. In addition to this the test procedures and the tools and methods used for the data processing and data modeling are described.

**Chapter 5 - Results:** This chapter presents the results of the testing conducted on the different materials.

**Chapter 6 - Discussion:** The discussion of the material selection, the results, and the solution is found in this chapter.

**Chapter 7 - Conclusion** A conclusion of the work done are presented in this chapter.

# Chapter 2

## Background theory

This chapter will present some background theory relevant to this thesis. A summary of multiple subjects will be covered. These summaries aim to give the reader useful knowledge for the understanding of the rest of this thesis. At first force and various ways of measuring it is presented. Then there will be a part on capacitive sensing in general, before a section about materials and the selection of them. At last some theory about data modeling are presented.

### 2.1 Force measurement

The SI measurement unit of force is the newton (N), and its symbol is  $F$ . One newton is the force needed to give a mass  $m$  of one kilogram an acceleration  $a$  of  $1 \text{ m/s}^2$ , see equation 2.1 and 2.2 [8]. A kilogram is defined by the mass of a metal cylinder kept at the International Bureau of Weights and Measures in France[17].

$$F = m \cdot a \quad (2.1)$$

$$1N = 1kg \cdot 1m/s^2 \quad (2.2)$$

Force has both magnitude and direction, making it a vector. Measurements of force are often done at balance, even if the definition is based on the acceleration of a mass. Systems measuring force can be qualitative or quantitative [17]. A qualitative system only measures if the force is greater than a preset threshold, and a quantitative system measures the actual force and represents its value as a signal. In *The Handbook of Force Transducers* [17] D. M. Stefanescu presents five various methods for measuring force. The five methods are reproduced in the list below.

- Weighing the unknown force against the gravitational force of a standard mass.
- Determining the acceleration of a known mass to which the force is applied.
- Converting the concentrated force to a distributed fluid pressure and measuring that pressure
- Balancing the force against an electromagnetically or electrostatically developed force.
- Measuring the strain produced in an elastic body by the unknown force.

For this thesis, it is the last point of the list that is the most relevant. Using a sensor to measure the compression of an elastic material to determine the force applied to the material, is strongly related to the last point. The papers in chapter 3 is also using this last method, by utilizing either springs or elastic materials.

The weight of an object is the force on it due to gravity. Some traditional methods to measure weight is to use a spring- or balance scale. The spring scale measures how much an object compress or extend a spring to determine the mass of the object. A balance scale compares the mass of the object to references, similar to the first point of the list of above.

Several various methods for electrically measure force are presented in [17]. These methods include among others resistive sensing, where the piezoresistive properties of materials are utilized, inductive sensing, and capacitive sensing.

## 2.2 Capacitive sensing

Capacitive sensing is done by electrically measuring the capacitance between conductors in a dielectric environment [4]. Materials have properties like the dielectric constant which a capacitive sensor can measure. The technology is well suited for integrated circuits [4] which makes it useful for small sensors. Capacitive sensors can be used in several different applications, such as measuring pressure, spacing, thickness, proximity, and touch.

The main part of a capacitive sensing system is a capacitor. As previously mentioned a capacitor consists of two electrodes separated by a dielectric material. The capacitor will store and hold electric energy on the electrodes if a voltage is applied across the terminals of the capacitor. If the voltage source is disconnected, the stored energy will be leaked or used by other components. A capacitor can only hold a given amount of charge, and the measure of this charge is called capacitance. The unit of capacitance is coulomb per volt, and it is measured in farad (F) [21]. This is seen in equation 2.3 where  $C$  is the capacitance in farad (F),  $Q$  is the charge stored on the capacitors plates and  $V$  is the applied voltage.

$$C = \frac{Q}{V} \quad (2.3)$$

There are three factors that determine the capacitance of a parallel plate capacitor. It is the area of the plates, the spacing between them and the properties of the dielectric material between these plates [21]. This is seen in equation 2.4, where  $C$  is the capacitance in farads (F),  $\epsilon_r$  the permittivity of the dielectric material,  $A$  the area of the plates,  $\epsilon_0$  the permittivity of free space, and  $d$  the distance between the plates.

$$C = \epsilon_r \frac{A\epsilon_0}{d} \quad (2.4)$$

In illustration of a parallel plate capacitor can be seen in figure 2.1a. An illustration of a planar sensor where the electrodes have been opened for sensing an object is found in figure 2.1b.

The dielectric material of a parallel plate capacitor can be a compressible dielectric elastomer. If this is the case an external force can be applied to the capacitor, and the measured capacitance will change due to the material compression.

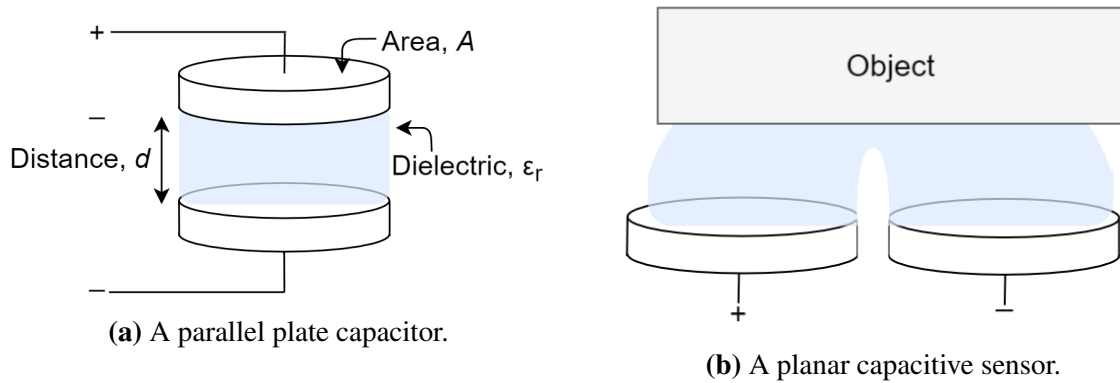
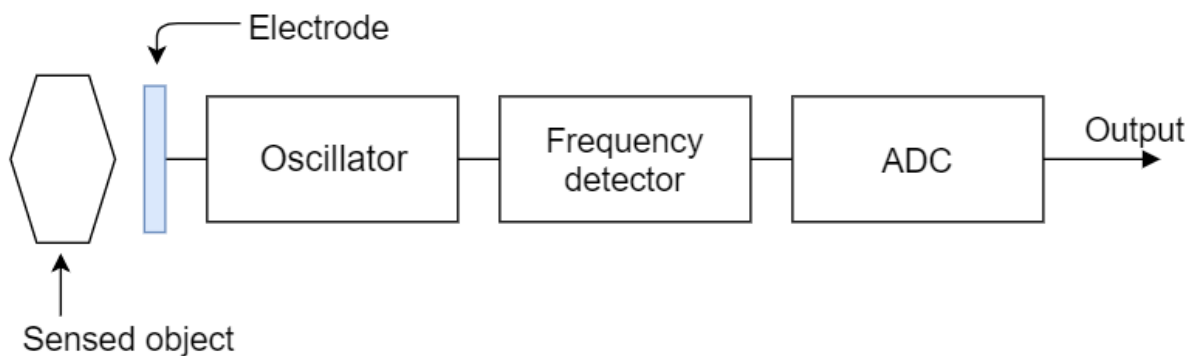

**Figure 2.1:** Illustrations of capacitive sensors.

### 2.2.1 Sensor configuration

The various types of capacitive sensors use different circuit design and electrode configuration. Two different configurations presented in L. K. Baxters *Capacitive Sensors: Design and Applications* are the single plate and the parallel plate configuration [4]. The use of a single circular plate with air as its dielectric is used for proximity detection. The capacitance increases when an object approaches. When measuring motion, or the properties of a dielectric material, the configuration with two parallel plates are beneficial.

As the capacitance of the sensor plates varies, it is essential with circuitry that converts this to an output signal. Characteristics that are important for this circuit is among others low noise, good linearity and an insensitivity for stray capacitance. A simple block diagram of a capacitive proximity sensor is included in figure 2.2. If an object is approaching the sensor, it will cause an increase in capacitance. This increase will lead to a change in the oscillator frequency which can be detected and converted to an output value.



**Figure 2.2:** Block diagram of sensor.

## 2.3 Materials

Materials are often separated into five families. They are metals, ceramics, polymers, glasses, and elastomers [3]. In addition to this, there are hybrid materials which are a combination of two or more materials. Materials in the same family have similar properties and often similar applications. Some examples of material properties and their symbols and units can be seen in table 2.1. Standardized test is used to quantify the properties of the various materials.

**Table 2.1:** Material properties

Property	Symbol and units
Price	$C_m$ (\$/kg)
Young's moduli	$E$ (Gpa)
Compressive strength	$\sigma_c$ (Mpa)
Thermal expansion coefficient	$\alpha$ (k $\$^{-1}$ )
Dielectric constant	$\epsilon_r$ (-)

The five material families are presented in [3]. As a brief summary it states that metals and ceramics are stiff with a high elastic modulus. Elastic moduli are the measure of a material's resistance against being elastically deformed if stress is applied to it. It also states that glasses is a hard and brittle material. It also states that polymers have a low elastic modulus. The properties of polymers are temperature dependent. The elastomers are based on polymers with elastic properties. These properties give an elastomer the ability to return its natural size and shape after it has been deformed. The properties of elastomers differ so greatly from other materials that special tests must be used to characterize them.

Some properties for elastomers that will be important for this thesis is Young's modulus, compression set, and compression stress relaxation. The Young's modulus is a measure of how a material responds to compression or tensile loads. A low modulus shows that less stress is required to strain the material. The compression set is a measure of the materials recovery to its natural size and shape after compression. With a compression set of 0 % the material is fully recovered, and with a compression set of 100 %, there is no recovery. The last property presented here is the compression stress relaxation. This is a measure of how much force a material pushes back with over time when it is being compressed with a constant force.

### 2.3.1 Material selection

When selecting a material for an application it is about finding the material that best matches the properties needed in the design. When promising materials are found they have to be compared to find the optimal one. A method for doing this is using an Ashby plot. Such a plot can be seen in figure 2.3 [26], where Young's modulus vs. density of 50 different materials are plotted. The Ashby plot can be used to compare the properties of various materials, and thus simplify the selection of them.

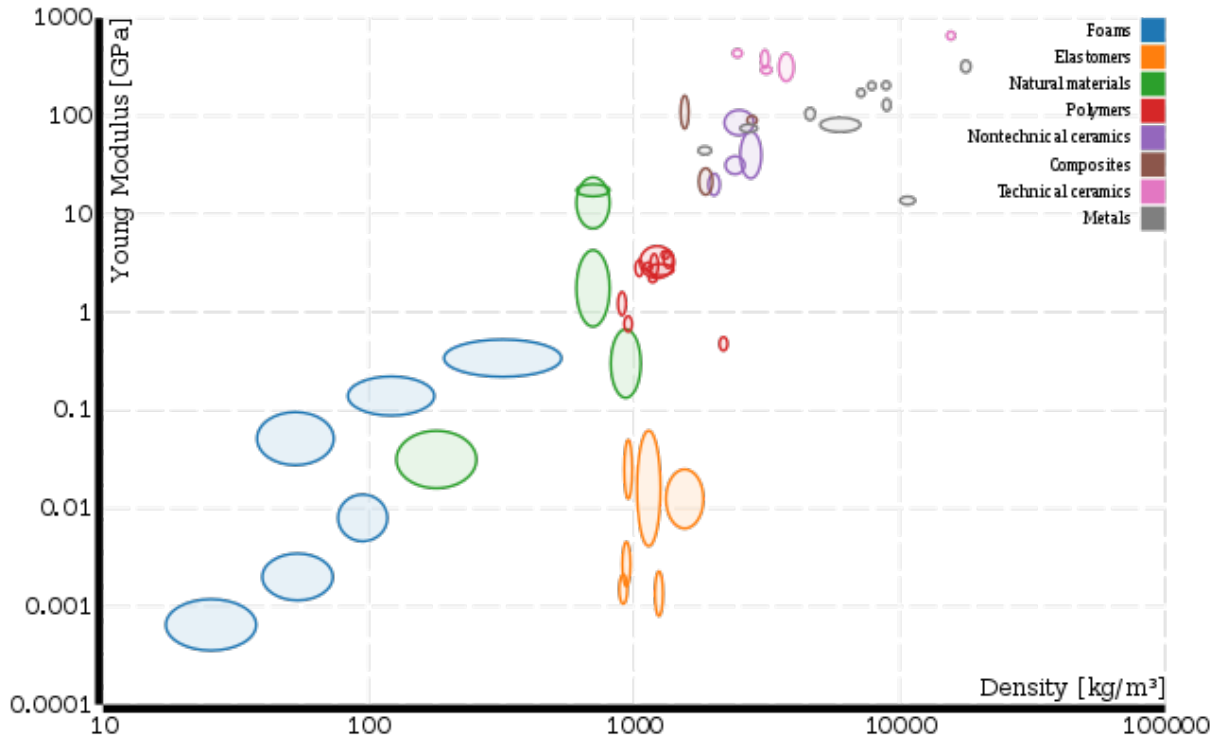

Figure 2.3: Ashby plot for Young's modulus vs density [26].

## 2.4 Fitting models to measured data

When data is collected it is necessary to analyze it. If a sensor is being characterized its input and output values have to be recorded. The results of this recording can be plotted as illustrated in figure 2.4. Where the sensor output is plotted vs. the sensor input. A way of defining  $X$  as a function of  $Y$  is to use nonlinear regression [11]. This is a way of finding the best fit model for the measured data. The data from the sensor is entered in a software which is used to find this model. When nonlinear regression is used it minimize the sum of the squared distance the data points is off the model curve [11].

It is also possible to plot the difference between the measured data and the fit. This is called a residual plot, and the residuals is mathematically found as seen below.

$$\text{Residual} = \text{Data} - \text{Fit} \quad (2.5)$$

The residual plot will be used to analyze how well the data model fits the data. Values in a data set that is far from the others is called an outlier. Such values may come from mistakes and errors, and an evaluation should be done if they should be included in the data. If the value comes from an error, it should be removed so it does not corrupt the results.

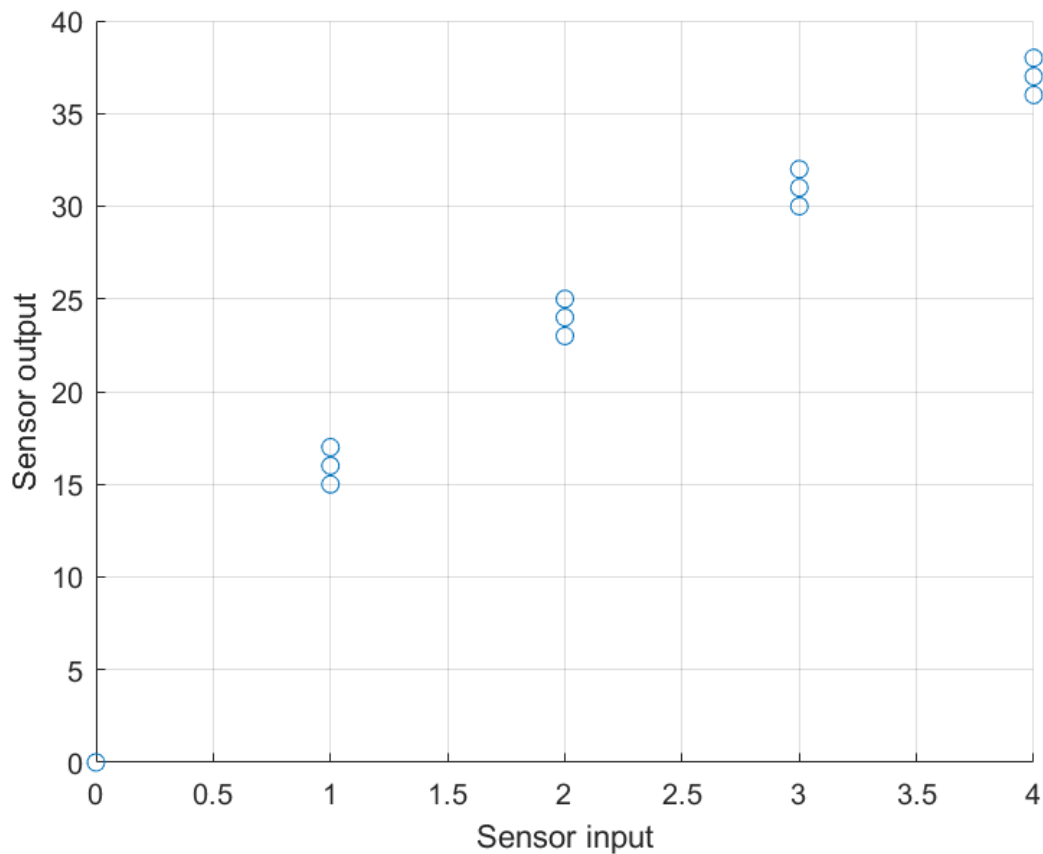

**Figure 2.4:** Illustration of scatter plot.

# Chapter 3

## Other work

### 3.1 Weight measurement using an inductive sensor

Texas Instruments (TI) have a reference design presenting a solution using inductive sensing to measure distance and weight [22]. Some features of this design are a power consumption of 37.8 mW, and an output resolution of 2 grams. The weight range characterized by the sensor is 100 grams to 750 grams. The inductive sensor measures distance. This distance is converted to a weight measurement by using springs with known characteristics. An image of the setup used when the system was tested is included in figure 3.1a. A metal plate is supposed to be thread on the metal rods and rest on the springs when measuring weight.

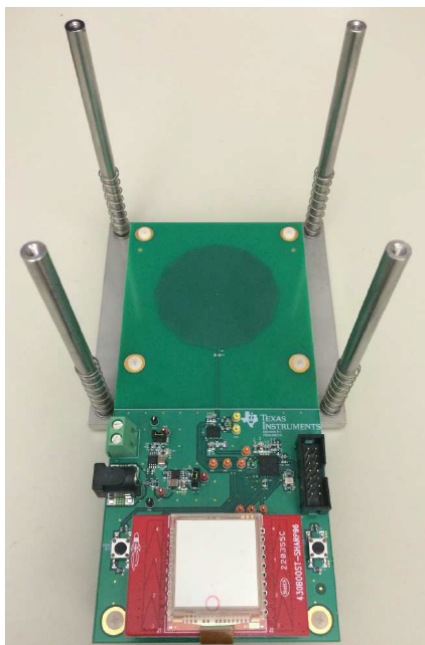

(a) Image of the design used by TI [22].

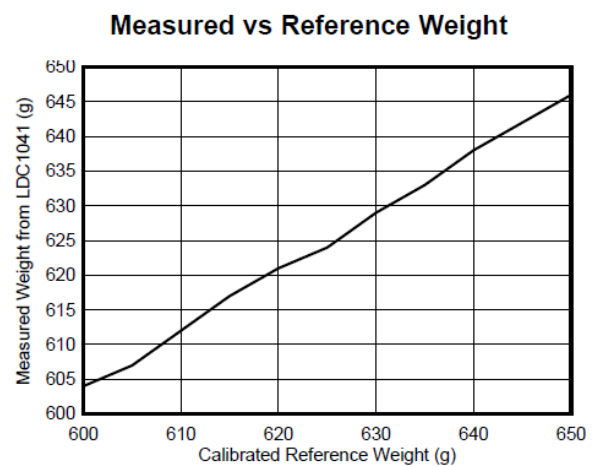

(b) Measured vs Reference weight for the design [22]

**Figure 3.1**

A printed PCB is used as the sensor, and an inductance-to-digital converter from TI is used. This converter has a resolution of 24-bits [23], allowing it to measure induction with a high resolution. This is a necessity if the goal is to measure weight and distance with high resolution. Figure 3.1b shows the results of the testing between 600 and 650 grams. As seen from the figure the measured weight is close to the reference weight, proving good results.



### 3.2 Mass measuring using a capacitive system

The paper *Development of capacitive mass measuring system* [1] presents the design, construction, and testing of an accurate capacitive mass sensor. An illustration of the sensor is included in figure 3.2a. The operation of the sensor is based on the mass of an object compressing a spring, and by that change the shielding effect on the main capacitor. This capacitor is marked with 1 and 2 in figure 3.2a.

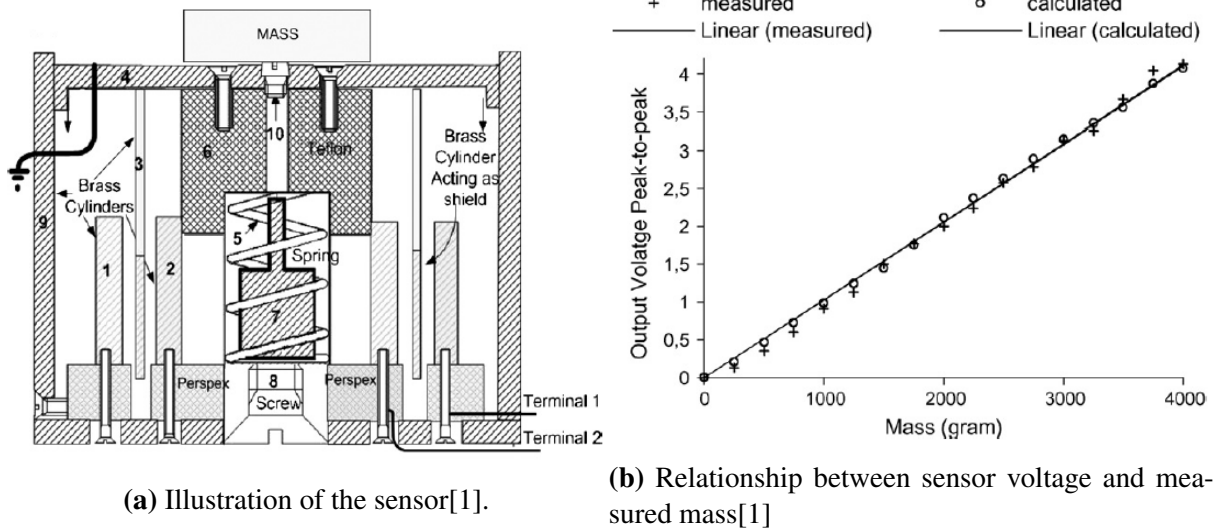
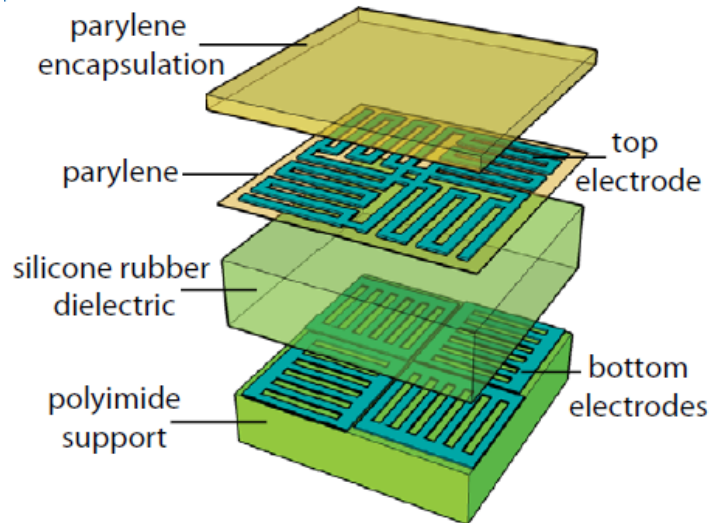

**Figure 3.2**

The relationship between the sensors output voltage and the measured mass is seen in figure 3.2b. As seen this relationship is strongly linear, and the calculated and measured values correspond closely. The capacitive sensor can measure mass up to 4 kg with the spring used in this paper. The authors claim that this range can be changed by using a spring with another spring constant.

### 3.3 Dielectric elastomers

In [6] a polymer-based flexible capacitive sensor for force measurements are presented. The developed solution is intended used in an application with skin-like sensing. An illustration of the developed sensor is included in figure 3.3. The sensors metallic electrodes are embedded in layers of polymers. When no load is applied to the sensor the distance between the top and bottom electrodes are  $11 \mu\text{m}$ . The elastic silicone rubber dielectric is compressed when a force is applied to the sensor. This will decrease the distance between the electrodes, and the capacitance will increase.



**Figure 3.3:** Illustration of the flexible capacitive sensor [6].

Another paper that presents a flexible capacitive tactile sensor is found in [9]. This solution is also intended used in a skin like application. An illustration of the sensor can be seen in figure 3.4a. It uses several layers of silicone, marked as PDMS in the figure, and two electrodes. When a force is applied to the sensor the air gap between the electrodes is changed, and the measured capacitance increase. The results for tests with a variation in thickness of the upper PDMS layers is seen in figure 3.4b. The results are strongly non-linear.

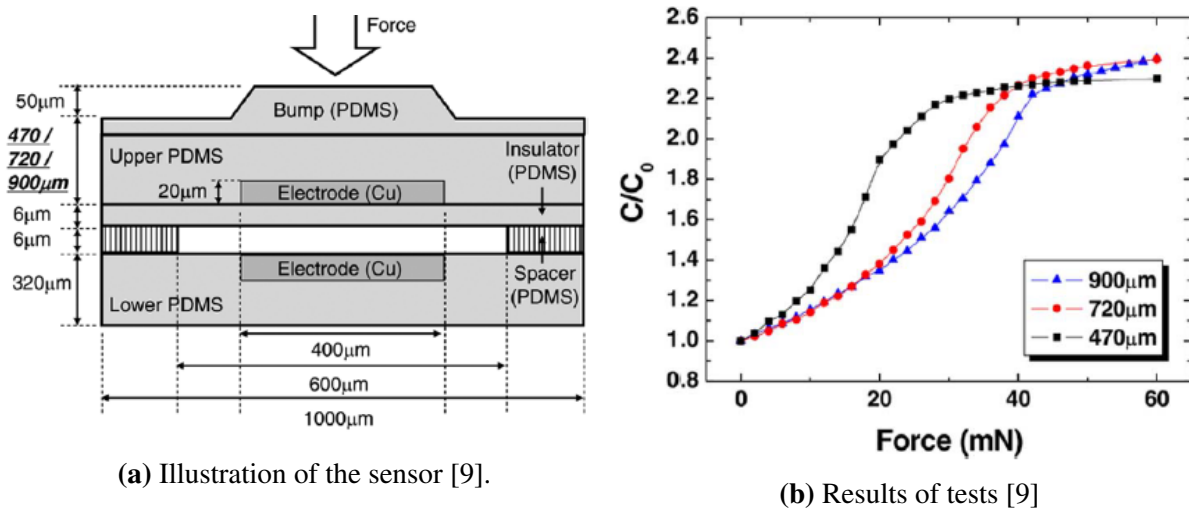

**Figure 3.4**

# Chapter 4

## Method of approach

This chapter first presents the sensor used in this work. Then the procedure for material selection and use of these materials are presented. A description of how the testing was performed will then follow. At last the use of Grafana [7] and Matlab [24] for processing the collected data will be examined.

### 4.1 The capacitive sensor

Disruptive Technologies wireless capacitive sensor can be used to measure touch, temperature, and proximity [5]. It is a sealed sensor with a size of 19x19x2mm. Its battery life can be as long as 15 years. While working with this thesis the sensor was configured as a proximity sensor with a maximum range of approximately 5 mm [10]. The sensors were set up with a one-minute sample time. An illustration of the sensor is seen in figure 4.1.

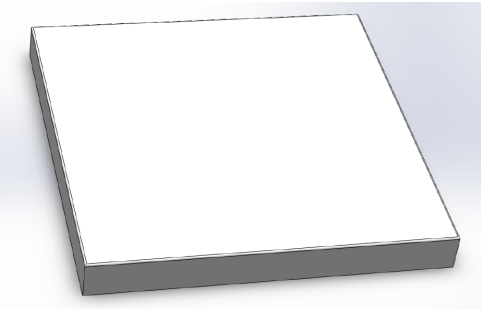

**Figure 4.1:** Illustration of the capacitive sensor.

The sensor was connected to a cloud connector that uploaded the sampled data to the internet. The sampled data was then stored in a cloud solution. The sampled values could be examined both in real-time and later using the open source software Grafana [7]. This software will be presented more closely in section 4.4.

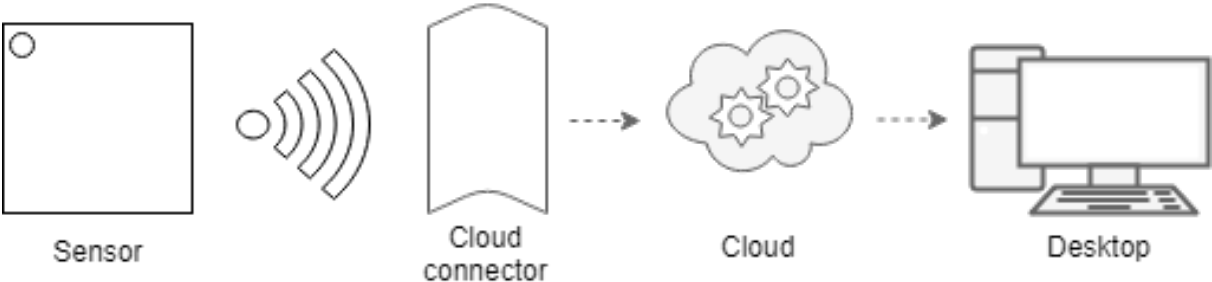

**Figure 4.2:** Illustration of the sensors connection.

## 4.2 The materials

This section will present the materials used in this thesis. It will cover material selection, the ordering of them, and the use of them. In chapter 2.3 the various material families are presented. The description of each family will reveal that metals, ceramics, glasses, and polymers are not suitable for an application like this. It is the elastomer family that is of interest. When selecting a suitable compressible material, a crucial part will be its availability. This complicates the search since producers and vendors will have to accept to offer a small sample of their material to be used in this thesis. So, in addition to finding materials with suitable properties, it also must be possible to order them in a small quantity.

The ideal solution would be to find the optimal material by comparing various materials and their properties using for instance an Ashby plot as described in chapter 2.3. The process for finding interesting materials in this thesis were to first survey which properties a suitable material would have. The second step was carried through by using the internet to find materials with these properties, and to contact vendors that could supply them. The application, expected material properties, and intended use of the material were explained to the vendors that responded to the initial inquiry. The ordered materials are presented in table 4.1, and presented in more detail below.

**Table 4.1:** Ordered materials

Material	Type	Size (mm)
Saint-Gobain NORSEAL <sup>®</sup> R10480S	Silicone sponge rubber	101.6x101.6x4.76
Saint-Gobain NORSEAL <sup>®</sup> R10480M	Silicone sponge rubber	101.6x101.6x4.76
TG2030	Silicone	19x19x4
TG6050	Silicone	19x19x4
L37-5S	Silicone	19x19x4
Bisco <sup>®</sup> BF-1000	Silicone foam	20x20x3.18
Bisco <sup>®</sup> BF-2000	Silicone foam	20x20x3.18
Poron <sup>®</sup> 4701-30	Polyurethane	20x20x3.18

The two first materials in table 4.1, from now on called respectively R10480S and R10480M, are both silicone sponge rubbers. These materials are compressible and flexible, and according to their datasheets [16] [15] they should have a compression set of 5 %. The main difference between them are that the R10480S is softer than the R10480M. It was these two materials that was tested as described in section 4.3.

The next three materials are silicone materials [18] [19] [20]. As they did not fit the application due to their lack of elasticity they will not be further presented.

Table 4.1 also contains two silicone foams, from now on called respectively BF-1000 and BF-2000. According to their datasheets [12] [13] these materials should have high compressibility, very low compression set, and low stress relaxation. The main difference between them is that the BF-1000 requires more force to be compressed than the BF-2000.

The last material in the table is a polyurethane, from now on called Poron-30. This material should also have a low compression set [14]. This material is cheaper than the BF-1000 and BF-2000. The last three materials in the table never arrived, and could not be tested.

The R10480S and R10480M was delivered in sheets of approximately 100x100 mm. When mounting these materials to the sensor a piece of 19x19 mm was cut out, and fastened with the adhesive they were delivered with. An illustration of this set-up is seen in figure 4.3 As an attempt to isolate the sensor from the objects compressing the material, a copper foil shielding tape [2] was fastened on top of the material.

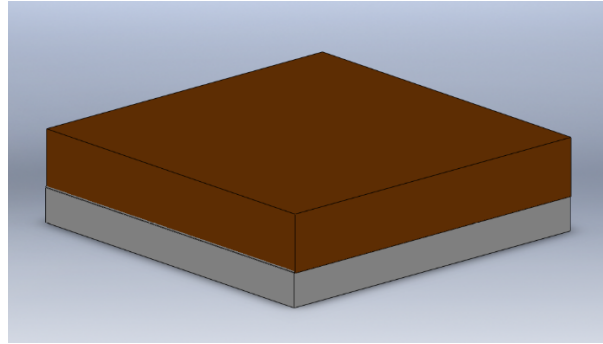

**Figure 4.3:** Illustration of material mounted to the sensor.

## 4.3 The testing

When testing the sensor solution there were mainly two different testing methods used. The first method used a digital force gauge mounted in a vertical stand. An image of this setup can be seen in figure 4.4a. The force gauge could measure both push and pull force, and the measured force could be displayed in either newtons or kgs. The test stand was operated manually by twisting a screw which lowered or heightened the force gauge. In principle, this method should have few sources of error, and it should have been a quick way of adjusting the force compressing the material attached to the sensor. A drawback of this test method was that the force gauge could not measure forces lower than 5N, or approximately 500 g. The characteristics of the materials tested contributed to complicating the process of adjusting the force gauge to the wanted force. These two problems provoked the second test method.

The second method used weights to compress the material. A test stand was built of straight and angled metal plates. An illustration of this test stand can be seen in figure 4.5. The sensor was placed at the center of this stand when testing. As seen in figure 4.5 two vertical bars were standing up from the horizontal top plate of the stand. The metal plates used as weights during testing had holes in them, which the two bars fitted through. This simplified the placing of the plates as the bars were used as guidance to avoid unequal distribution of weight. An image of a material under test is found in figure 4.4b.

The weights used in the second test method were ten metal plates, and five metal weights of 50, 100, 200, and 500 grams. The weight of each metal plate was controlled by an electronic kitchen scale with a resolution of 0.1 grams for the range in question. The precision of the scale was 0.5 grams. The measured weight of each plate is seen in table 4.2.

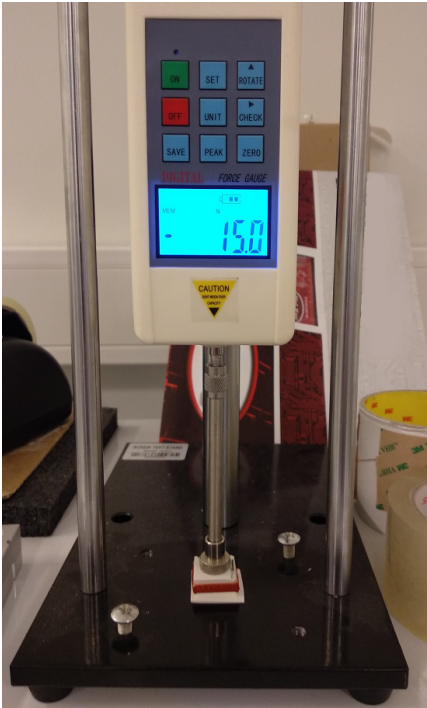

(a) The force gauge

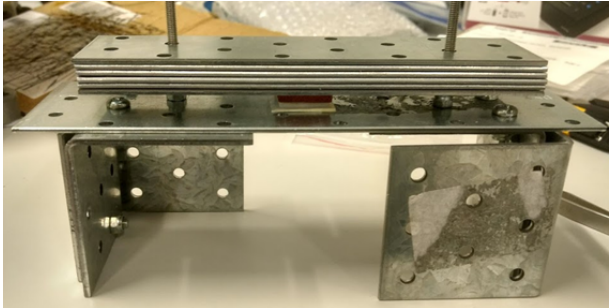

(b) The test stand and the metal plates

Figure 4.4

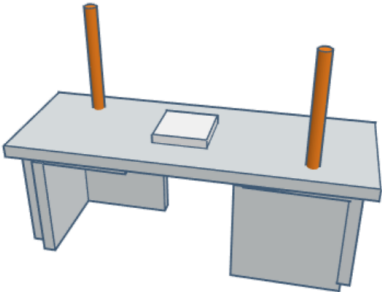

Figure 4.5: Sketch of test stand.

Table 4.2: The plates weight

Plate number	1	2	3	4	5	6	7	8	9	10
Measured weight (g)	98.3	96.2	96.4	93.5	94.6	97.0	98.4	98.2	95.1	92.5

Both test methods have in common that they were done at room temperature, and that the applied load had to be manually noted during the testing. The applied load and weights used to compress the material were noted so they paired with the measured sensor value at the time.

## 4.4 The processing of data

The software used to examine the values from the sensor in real-time was Grafana [7]. This software is run as a web application and is used to visualize, graph and monitor time series data. An illustration of how the dashboard in Grafana was set up can be seen in figure 4.6. Each sensor had its own graph where the measured value were plotted against time. An increase of the plotted value is equal to a decrease of capacitance, and a decrease of the plotted value corresponds to an increased capacitance. In practice this would mean that an object compressing the material attached to the sensor will cause a decrease of the plotted value, and vice versa.

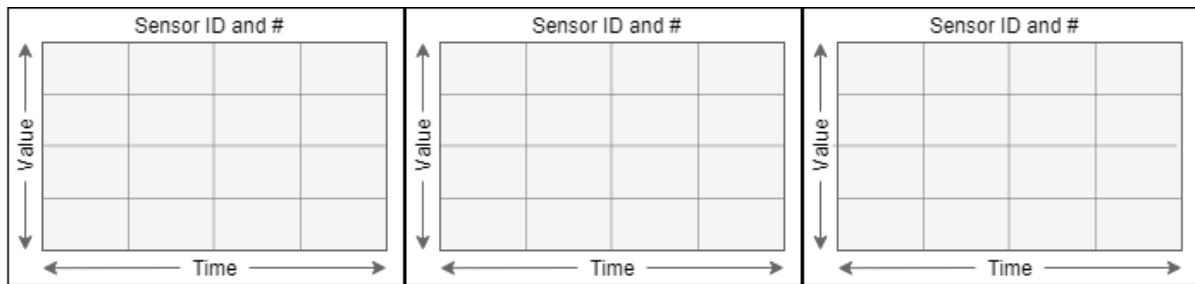

**Figure 4.6:** Illustration of Grafana dashboard.

The sensor data were exported from Grafana as comma-separated values. These values contained data about what time each sample was taken and the value of each sample at that time. Matlab [24] was used to process and analyze this data. The comma-separated values contained a time-stamp and value for every 30 seconds the sensor had been used. Since the sensor was set up with a sample time of one minute, redundant null-values had to be removed. This was solved by creating Matlab functions that imported and removed the redundant values. This is illustrated in the listing below, where line one imports the sensor values from the file, and line two removes the null-values. The force, or weight, compressing the material during the tests was added manually to complete the data set.

```

1 values_raw = import('sensor_values.csv');
2 values = remove_NaN(values_raw);

```

The plotting functions built into Matlab were used when plotting the test results. When plotting the sensor values against time, some manipulation of the time stamps were necessary to get the correct format. To analyze the results and to create a data model the Matlab Curve Fitting Toolbox[25] were used. This toolbox provides among other things functions for fitting a curve to a series of data. The same toolbox were used for plotting and analysing the residuals from the fitted model.

# Chapter 5

## Results

This chapter will present the results of the tests described in section 4.3. The materials tested were attached to the sensor, and the collected data was processed as described in section 4.4. This chapter is split into three main parts. The first part covers the initial testing performed with the digital force gauge. The main results of this tests are presented in section 5.1. The second part contains the main results from the test procedure using weights. The results of this tests are again split up into material types, presenting the results of the R10480S first and then the results of the R10480M. At last, a summary of the results can be found at the end of this chapter.

As previously mentioned in section 4.2 the silicone materials L37-5S, TG2030, and TG6050 proved to be unsuitable for the intended application. All the three materials were compressible, but their compressive set was too high as they wouldnt bounce back to their natural state after a compression. For this application it is very important for the selected material to regain its original size after a compression. The three materials mention above were thus omitted from further testing.

### 5.1 Initial tests

During the initial testing, both the R10480S and the R10480M were tested using the force gauge. The main results are seen in figure 5.1 and figure 5.2. These results were achieved by placing the sensor in the test stand and compressing the material by setting the force gauge to the desired force. When the sensor measured a stable value, the force was removed, and the material could go back to its natural state. After the measured values indicated that the material was back in its native state, the material was compressed again by setting the force gauge to a new force. For each compression of the material the forced used and its corresponding sensor value was registered.

The results from testing the R10480S by setting the force gauge to approximately 5, 10, 15, 20 and 25 newtons can be seen in figure 5.1. As expected a higher force compresses the material more than a lower force. The values measured by the sensor corresponds to this, as the value decreases when the compression increases. When the force compressing the material is removed, the sensor measures approximately the same values as before the testing began each time. The exception is the values measured after the first compression using 5 newtons. For these measurements the sensor value is only 210-211, and well below the average value of 215.9. The average sensor values for the applied forces can be seen in table 5.1.



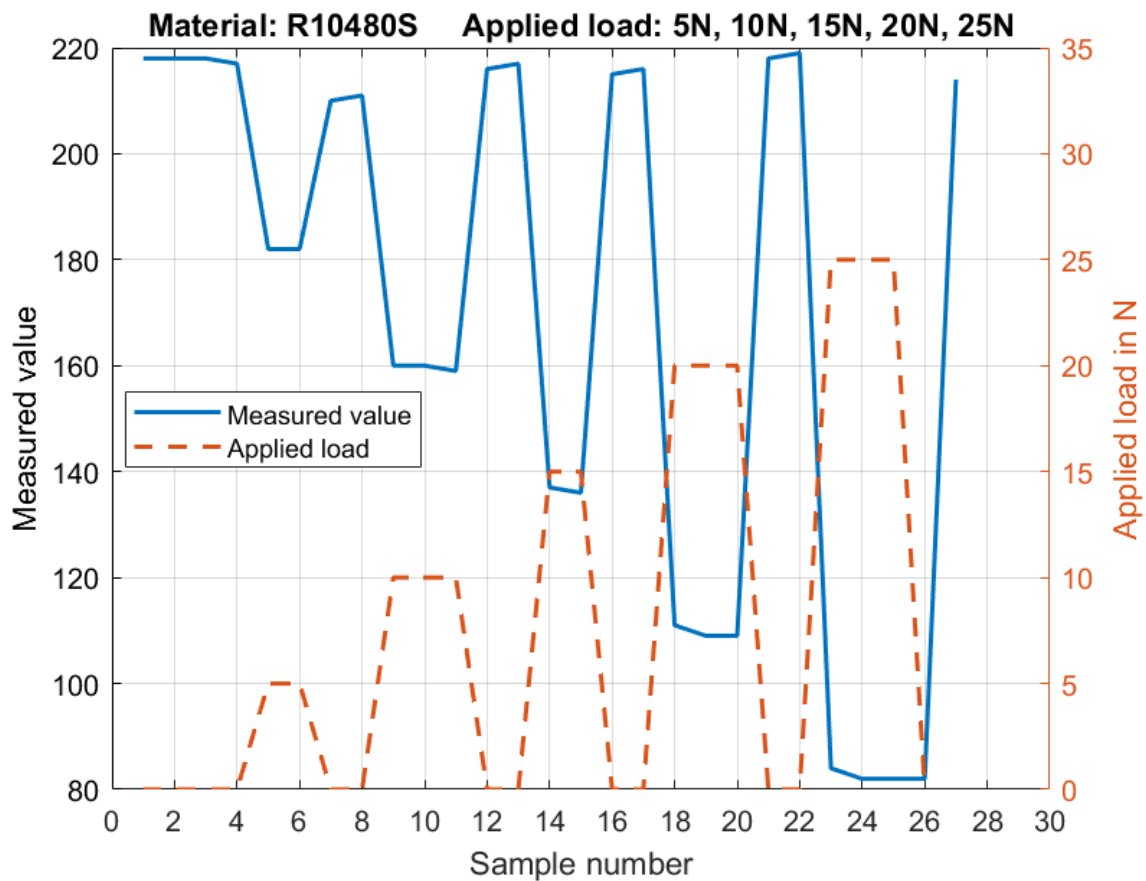
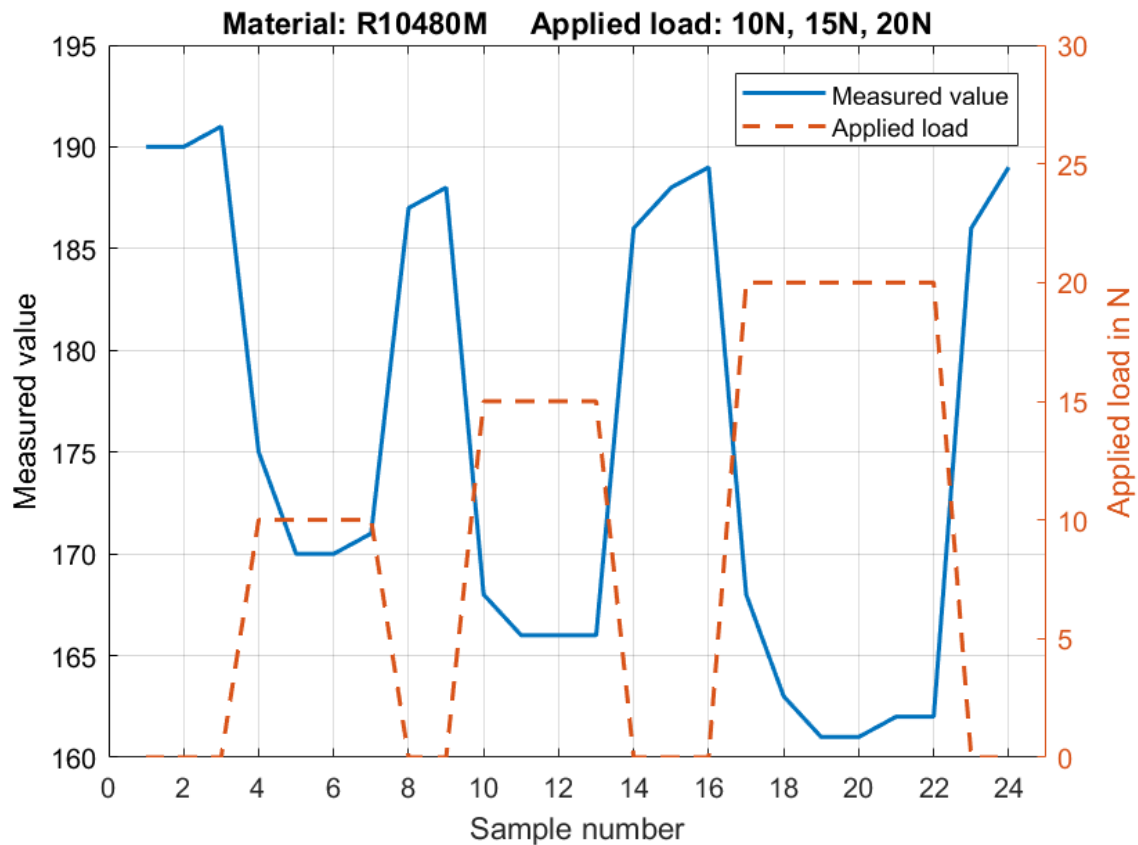

**Figure 5.1:** Plot of the results from testing the R10480S using the force gauge.

**Table 5.1:** Average sensor values for R10480S

Material: R10480S Test method: Force gauge						
Applied force (N)	0	5	10	15	20	25
Avg. sensor value	215.9	182	159.67	136.5	109.33	82.5

The same type of test was conducted using the R10480M by setting the force gauge to approximately 10, 15 and 20 newtons. Figure 5.2 displays the results of this test. As with the R10480S the sensor value decreases when the force compressing the material increases. When adjusting the force compressing the material, the change is not instantaneous. This can be the reason for the sensor not measuring a stable value right away. When removing the force compressing the material it takes some samples before the material achieves its natural state again. The measured value between each compression is not as high as the value measured prior to the testing. Table 5.2 contains the average sensor values for the applied forces. Compared to the average values from the similar test performed with the R10480S, the change in sensor value is less using the R10480M.



**Figure 5.2:** Plot of the results from testing the R10480M using the force gauge.

**Table 5.2:** Average sensor values for R10480M

Material: R10480M Test method: Force gauge				
Applied force (N)	0	10	15	20
Avg. sensor value	188.4	171.5	166.5	162.83

A problem when using the force gauge for testing the solution was the adjustment of the force compressing the material. Due to its manual adjustment, it was hard to set it to for instance exactly 10 newtons. Another problem that revealed itself during these initial tests was stress relaxation. After setting the force compressing the material to for instance 15 newtons, the material was compressed and the sensor measured constant values. The force gauge, which measures the force the material pushes back to the gauge, unveiled that the force measured by the gauge decreased. This implies that the materials over time push back with less force. A result of this is that the force used to compress the materials in this initial tests was not constant. Over time the force decreased, while the compression was constant. If a weight was used to compress the material instead of the force gauge this would be the other way around, the force would be constant and the compression would increase.

As a result of this another test was performed where a kitchen scale was placed under the sensor while it was tested with the force gauge. The motivation for this test was to reveal if the material would compress more over time if applied to a constant force. The idea was for the springs in the scale to push the sensor against the force gauge, and thus maintain a constant force applied to the sensor. The results of this test is found in figure 5.3. The material used was the R10480S and the force gauge was set to 10 N and 15 N, with and without the spring scale under the sensor.

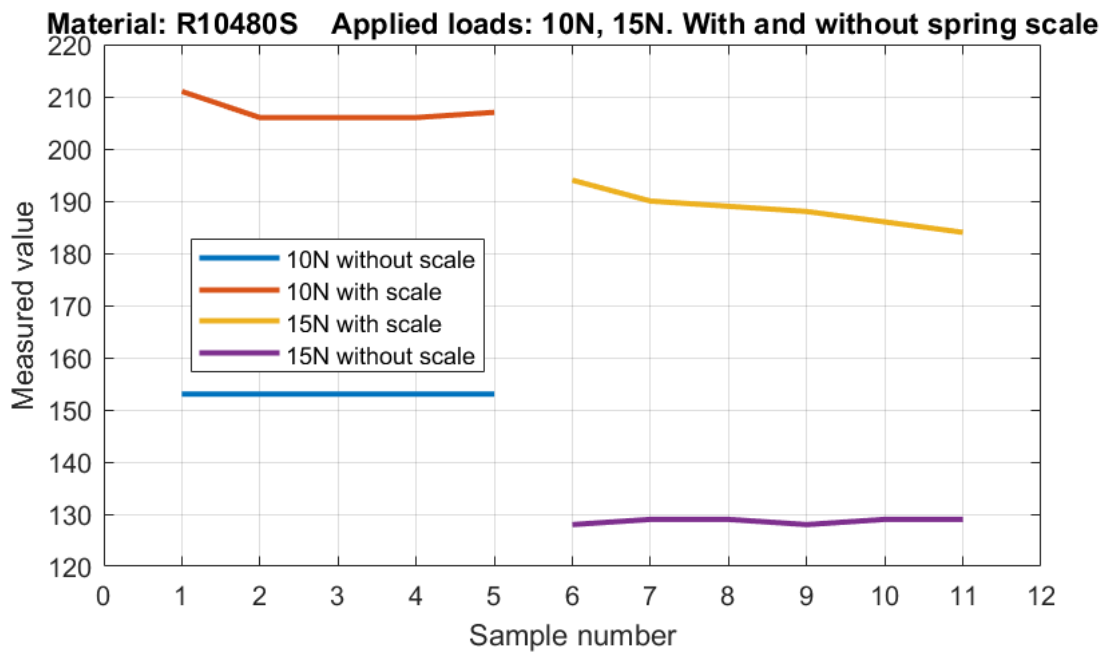

**Figure 5.3:** Plot of the results from testing the R10480S using the force gauge and spring scale.

For both forces the measured value is much higher when the spring scale is placed under the sensor. This is irrelevant as the point of the test was to examine if the material would be compressed more over time. When inspecting figure 5.3 further it shows that the measured values without the scale is constant, or close to constant. With the weight the measured value decreases over time. This is especially the case with 15 N compressing the material. A decrease of measured value for the same force, indicates that the material is compressed more over time due to stress relaxation.

## 5.2 Testing with weights

For the additional testing, the test stand and the weights were used. The results presented later in this section come from these tests. An illustration of the test stand can be seen in figure 4.5 in section 4.3. As previously described the sensor was placed in the center of this stand and weights were placed upon it, thus compressing the material. It was the detection of stress relaxation during the initial testing that provoked this new test method. The working hypothesis was that the weights would compress the materials more over time because of stress relaxation. This would again mean that the values measured by the sensor would change over time, as indicated by the results seen in figure 5.3. For the practicality grams will be used instead of newtons, as the measure of force for the upcoming results. The average gravity on earth is approximately  $9.81 \text{ m/s}^2$ , and so the force pulling an object of 100 grams downwards will be approximately 0.981 N according to equation 2.1 in section 2.1. For these tests it is the change in the measured value that is important, and not the exact force that is applied to the sensor. In the same way as with the previous tests, the applied force to the sensor had to be manually recorded. In this case it was the weight compressing the material that was noted and added to complete the data set.

The Curve Fitting Toolbox for Matlab that was introduced in section 4.4 was used to fit a curve to the data points. Both the outliers and the measured values without an applied load were omitted from this fit. The curve fitting was consequently done for the measured values when a load was compressing the material. The outliers were identified by being the first sample after placing or removing a weight. When this sample did not fit the trend, it got marked as an outlier. As the weights used could affect the dielectric constant, the change in measured value between no load and a load could be unnatural large. The metal weights are assumed to have the same dielectric constant, so it is the change in measured value for the various weights that is of interest.

### 5.2.1 R10480S

The first tests using the test stand was done using weights of 50, 100, 200, and 500 grams. The results of this test are found in figure 5.4. Several series of measurements were done for each weight, and the results are combined into one plot. Each weight was placed upon the sensor, after some samples the weight was removed, and the material returned to its original state. The outliers that are distant from the other measurements for the same weight are marked with diamonds.

As previously described the measured values for no load and the outliers are omitted from the data used to fit the curve. As seen in figure 5.4 the values for no load is too high to fit the curve. Another matter to point out is the large spread of values measured for a load of 500 grams. Equation 5.1 represents the fitted curve, and the equations coefficients can be found in table 5.3. The residual plot for the fitted model is found in figure 5.5.

$$f(x) = a \cdot e^{b \cdot x} + c \cdot e^{d \cdot x} \quad (5.1)$$

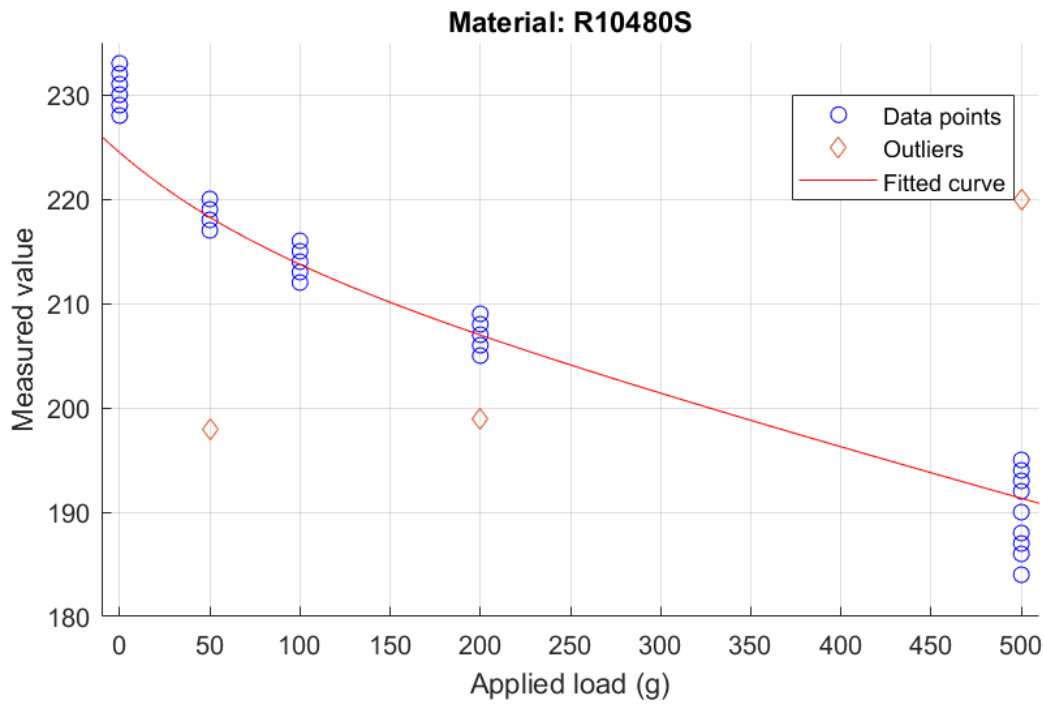

**Figure 5.4:** Plot of the results from testing the R10480S using weights.

**Table 5.3:** Coefficients for equation 5.1

Coefficient	a	b	c	d
Value	7.348	-0.01275	217.1	-0.0002529

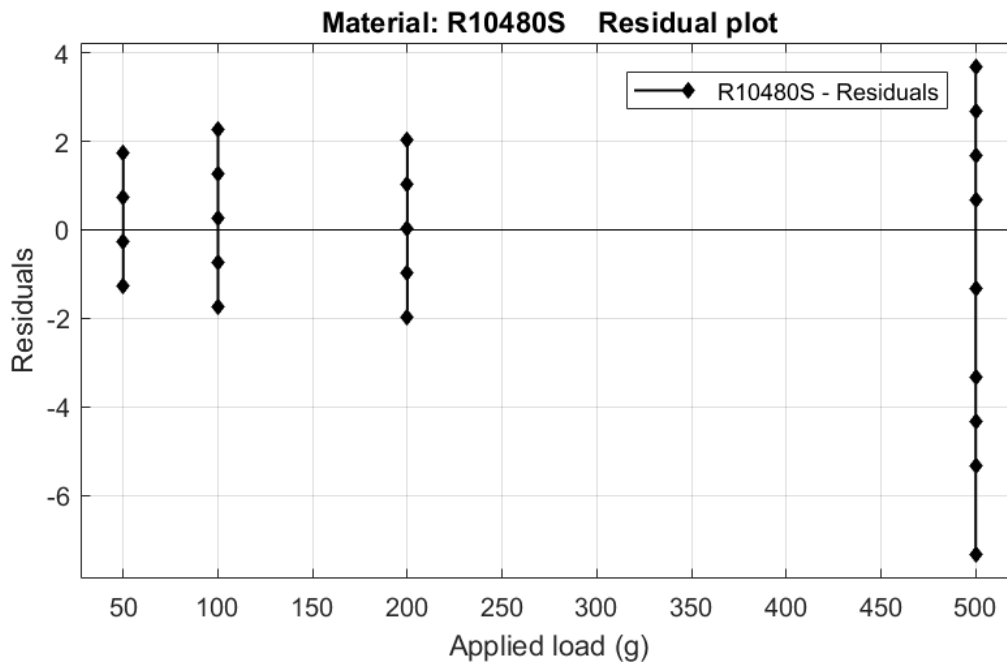

**Figure 5.5:** Residual plot for the fit in figure 5.4.

To decrease the range between the weights used, the test was developed further using ten metal plates with a weight of approximately 100 grams each. The result of this test is found in figure 5.6. The test was done by placing a plate upon the sensor, and then wait for the sensor to measure values. When the sensor sampled a constant value a new plate was added upon the sensor, and thus increasing the force compressing the material. Errors due to misplacing a weight or other clear errors are not included in figure 5.6. The fitted curves equation is found in 5.2, the equations coefficients in table 5.3, and the residual plot for the fit is found in figure 5.7.

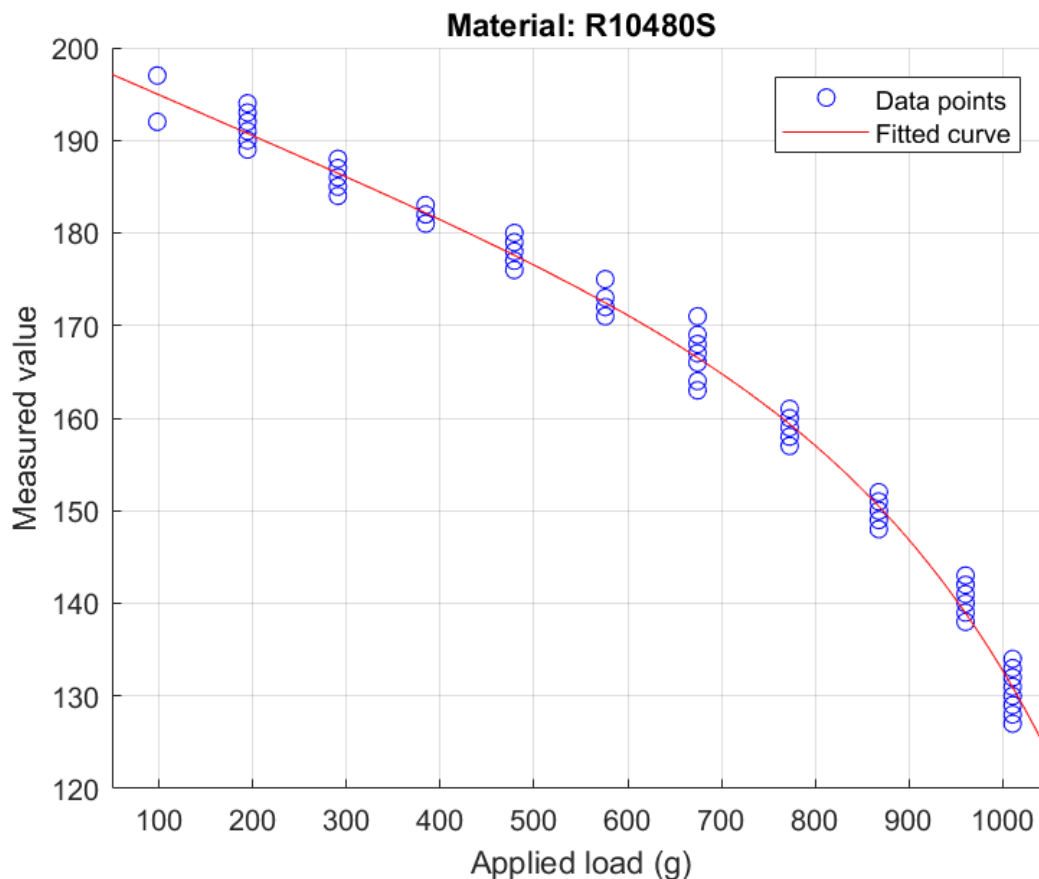
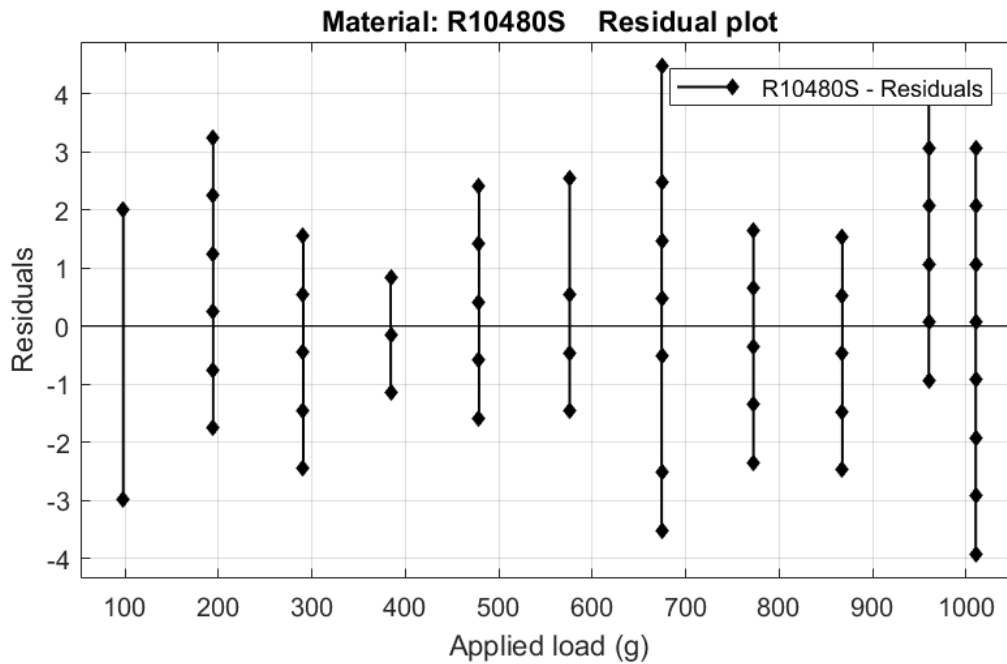

**Figure 5.6:** Plot of the results from testing the R10480S using the weights.

$$f(x) = a \cdot e^{b \cdot x} + c \cdot e^{d \cdot x} \quad (5.2)$$

**Table 5.4:** Coefficients for equation 5.2

Coefficient	a	b	c	d
Value	-0.2423	0.004752	199.6	-0.0002163



**Figure 5.7:** Residual plot for the fit in figure 5.6.

In figure 5.8 the results of a test with a constant load is seen. Approximately 1460 grams were placed upon the sensor, and the sensor sampled values for about two hours. It is seen that the measured values is similar to an exponential decreasing function.

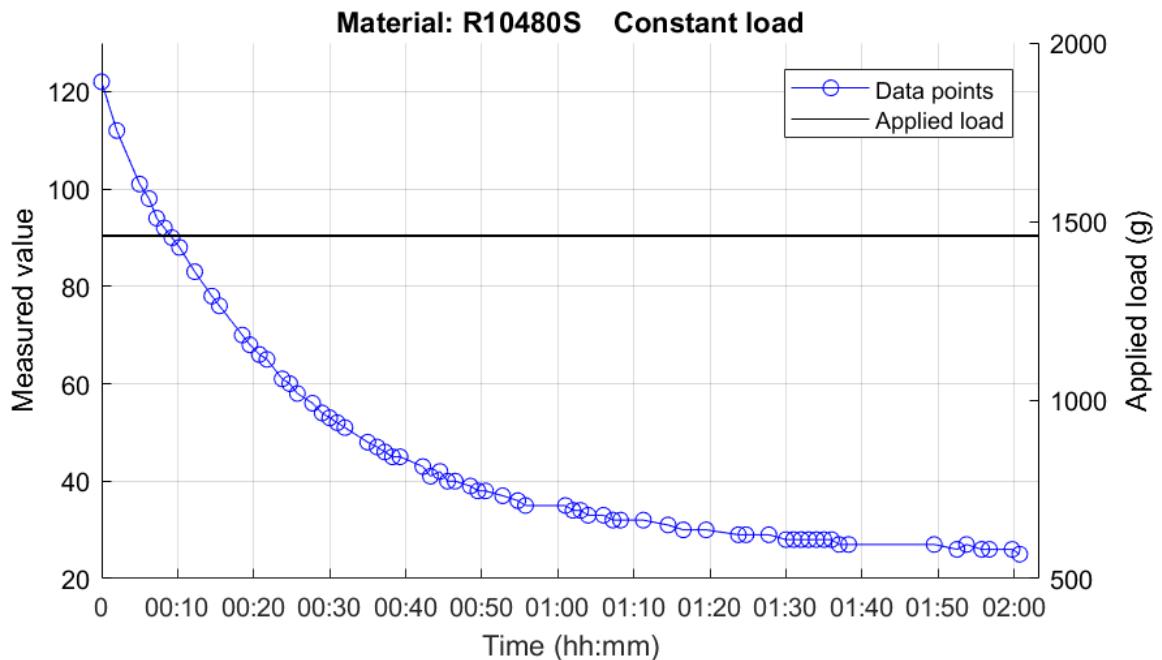

**Figure 5.8:** Plot of the results from testing the R10480S under a constant load.

After removing the constant load of 1460 grams the material used about 20 minutes to come close to its normal state, and over 40 minutes to be completely restored. This is seen in figure 5.9 which contains the samples taken after the constant load was removed.

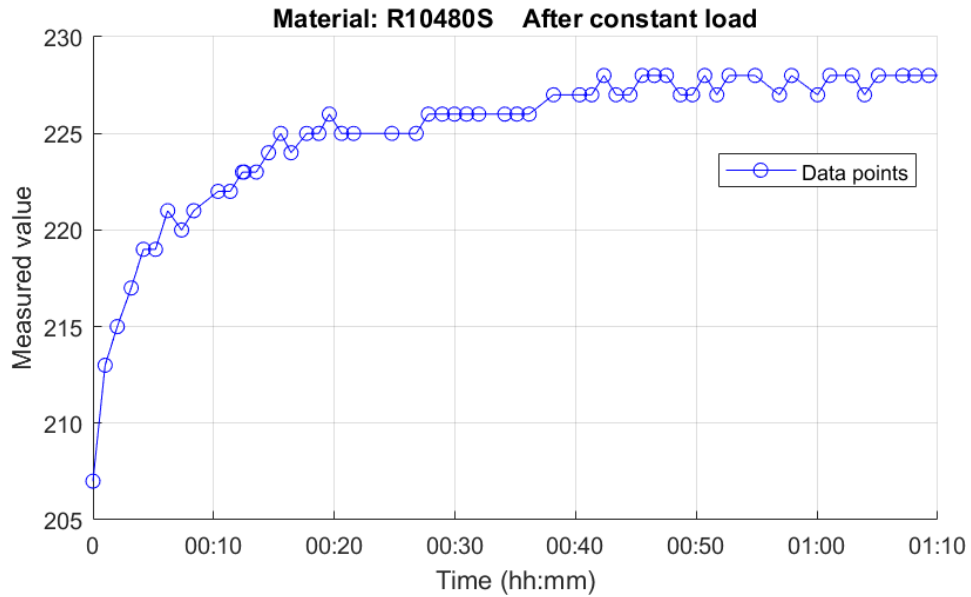

**Figure 5.9:** Plot of the results from removing the constant load.

### 5.2.2 R10480M

The same test using weights of 50, 100, 200, and 500 grams was carried through using the material R10480M. The procedure was the same as described in section 5.2.1 for the same test. The result is found in figure 5.10. The number of outliers is higher for this test than the similar one done with the R10480S. Another thing to be noted is that the values measured with no load is higher than predicted by the fitted curve. The equation for the fitted curve is the same as in equation 5.1 and 5.2, and its coefficients are found in table 5.5. Figure 5.11 contains the residual plot for the data model.

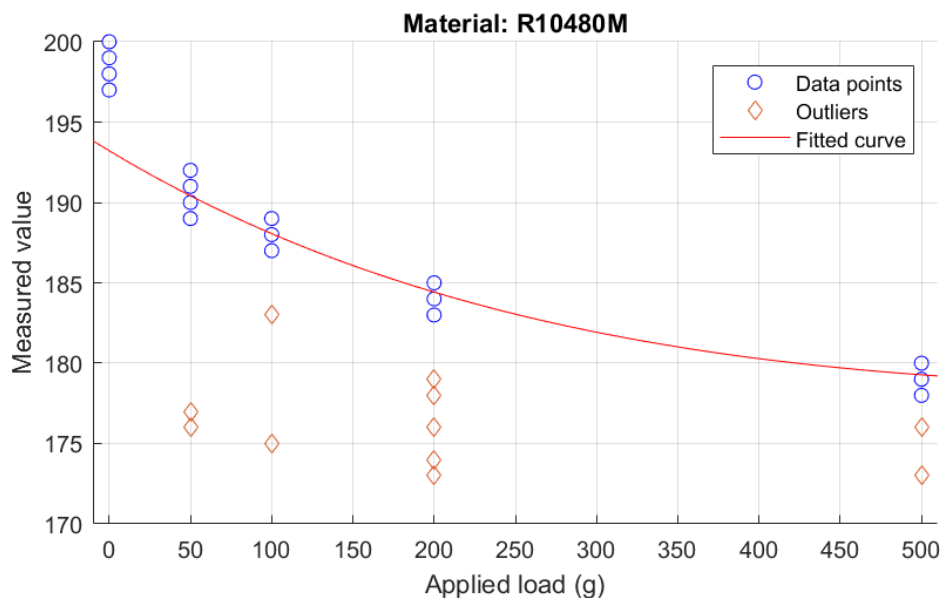
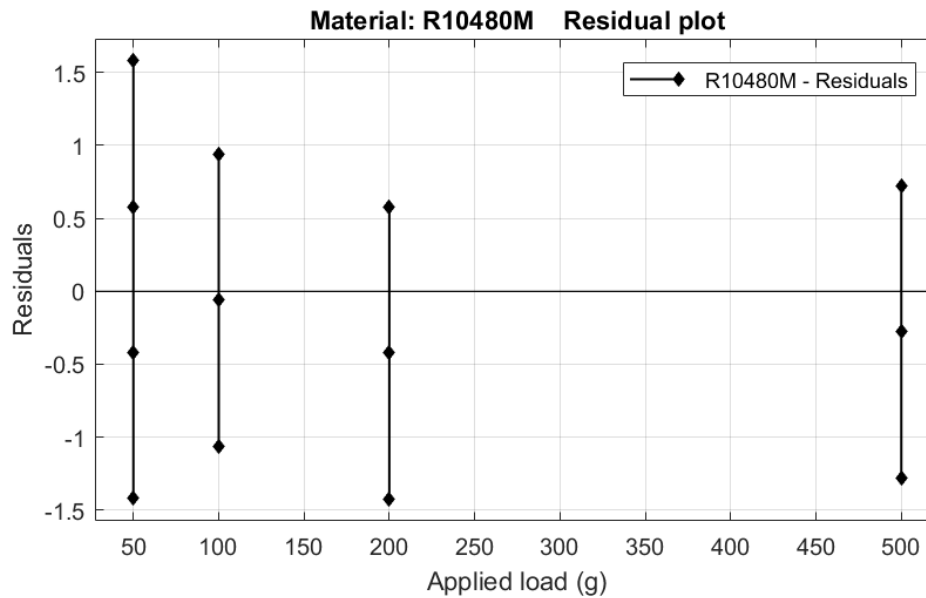

**Figure 5.10:** Plot of the results from testing the R10480M using the weights.

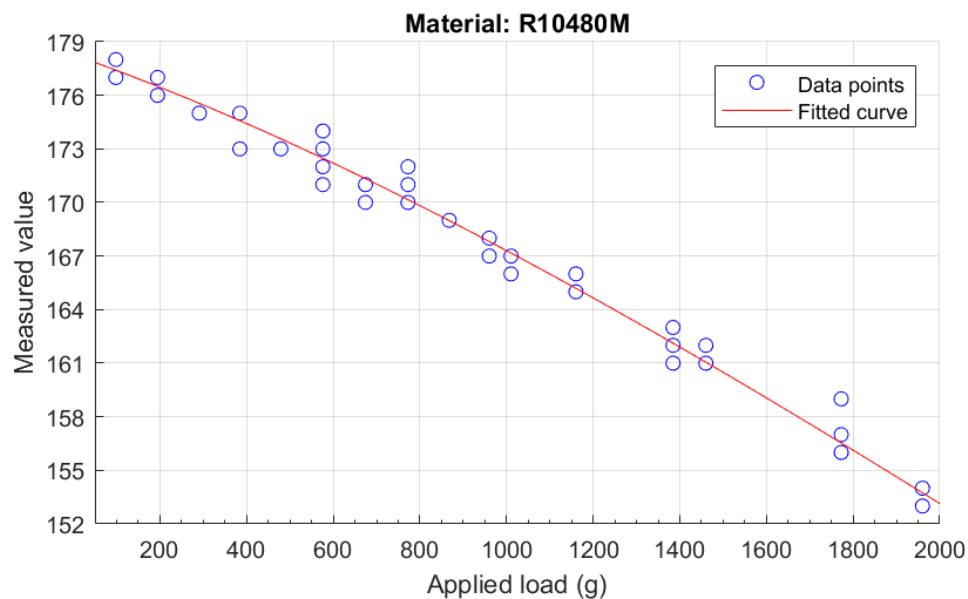

**Table 5.5:** Coefficients for the the fitted curve.

Coefficient	a	b	c	d
Value	23.78	-0.002913	169.4	-0.00005014

**Figure 5.11:** Residual plot for the fit in figure 5.10.

As with the R10480S this material was also tested with the metal plates. The procedure was the same as described for the R10480S, except for an extension of the data series by using more weights to compress the material. The result of this test is found in figure 5.12. The equation for the fitted curve is the same as previously, and its coefficients can be seen in table 5.6.

**Figure 5.12:** Plot of the results from testing the R10480M using the weights.

**Table 5.6:** Coefficients for the the fitted curve.

Coefficient	a	b	c	d
Value	35610	-0.002337	-35430	-0.0002346

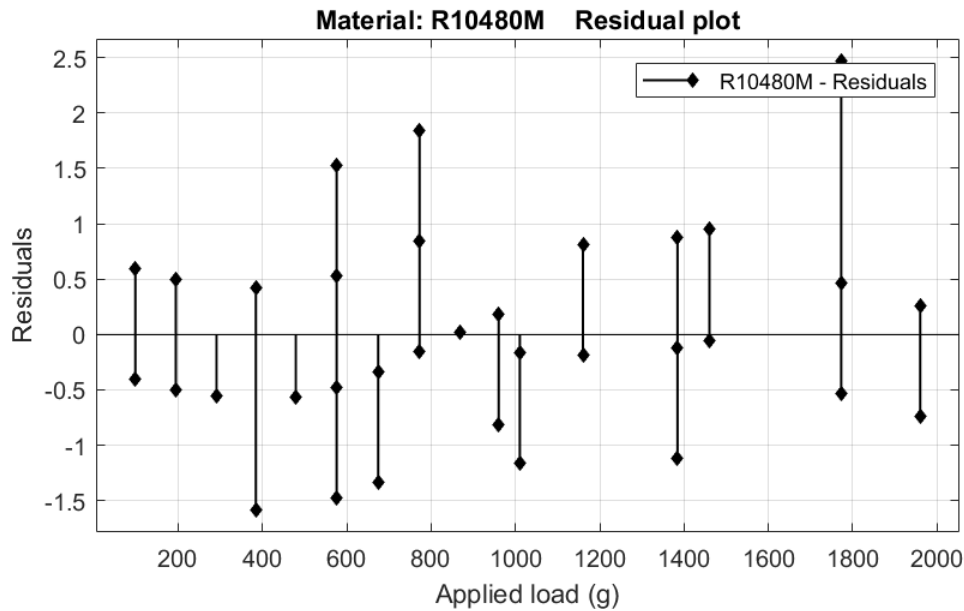

**Figure 5.13:** Residual plot for the fit in figure 5.12.

A constant load of 1960 grams was placed open the sensor with the R10480M material, and the sensor collected samples for approximately three and a half hours. These samples are plotted in the graph found in figure 5.14. The measured values decrease over time, which indicates that a constant load compresses the material more over time.

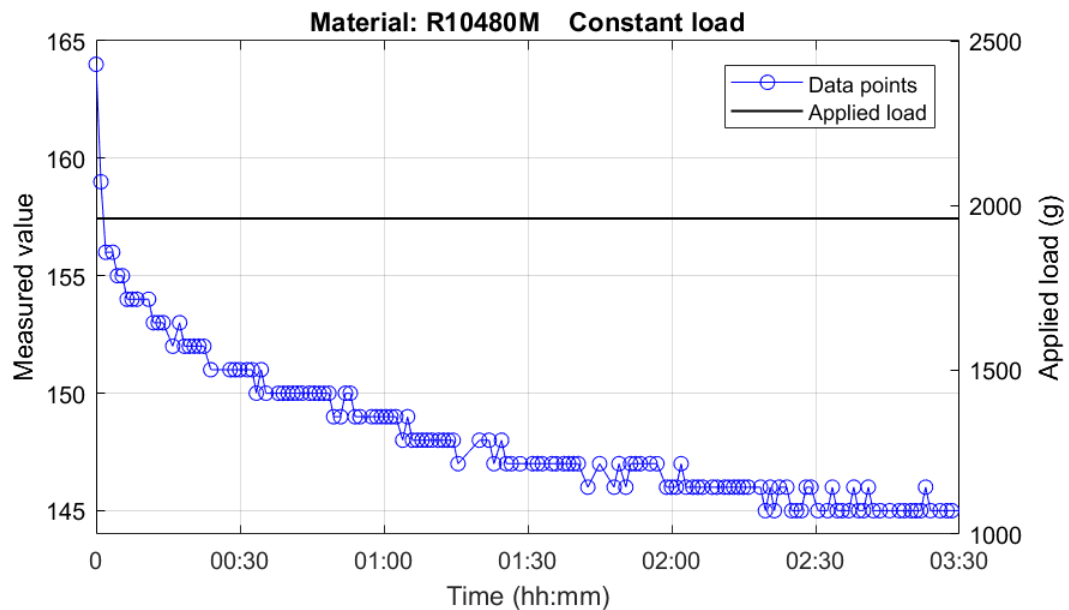

**Figure 5.14:** Plot of the results from testing the R10480M under a constant load.

## 5.3 Summary of test results

Since the three silicone materials L37-5S, TG2030, and TG6050 was disqualified from further testing due to their properties, the tests were done using the materials R10480S and R10480M. Both materials have gone through the same tests, and their results are covered in detail in the previous sections.

The first test the materials were exposed to was carried through using the force gauge. This test showed that the values the sensor measured corresponded to the force compressing the material. Another thing this test method revealed was stress relaxation in the materials. This discovery in combination with insufficiency's in the test method led to testing using weights. The results from these tests were fitted with curves to create data models. Residual plots for the fitted curves was included to simplify the evaluation of the fit.

# Chapter 6

## Discussion

This chapter will discuss the work of this thesis, starting with the selection of materials. It will then move forward to discussing the results presented in chapter 5. The discussion will cover both things that could have been done better and matters that in the future can be explored further. In addition to this the solution used in this thesis will be evaluated. At the end of the chapter, some alternative ways of using the sensor to measure force will be presented.

### 6.1 Choice of material

In section 2.3 important material properties for an application like this is presented. A way of selecting an optimal material using, among other things, Ashby plots are also introduced. After studying various materials, four different types of elastomers were ordered believed to be fit for measuring force. It was the three silicone materials, that turned out to be unsuitable, the two silicone rubber materials, the two silicone foam materials and the polyurethane material.

In the end, only two materials were tested. The Saint-Gobain NORSEAL<sup>®</sup> R10480S and the R10480M, both were silicone rubbers. It would have been profitable for the study if a wider range of materials were tested. It was unfortunate that the shipping containing the Bisco<sup>®</sup> BF-1000, the Bisco<sup>®</sup> BF-1000 and the Poron<sup>®</sup> 4701-30 never arrived. These materials would have given the thesis more depth, and they could possibly have been a better fit for this application. Another problem that restricted the supply of materials was the difficulties finding vendors that responded to inquiries, and that could provide samples of their materials.

## 6.2 The test results

This section will be built up similarly as the chapter presenting the results. At first, the results of the tests using the force gauge are discussed. Then the discussion of the results from using the test stand and weights are presented. A discussion of the sensor solution with the two materials will then follow before a summary is presented.

### 6.2.1 The initial testing

As described in the previous chapters the sensor solution was first tested using a digital force gauge. As seen in both figure 5.1 and figure 5.2 compressing the material with higher forces caused the sensor to measure lower values. This was as expected since a higher force would compress the material more, causing less spacing between the sensor and the object above it. The capacitance measured by the sensor increased.

In figure 5.1 which contain the results of the test that compressed the R10480S with 5, 10, 15, 20, and 25 Newtons the measured values are almost linear regarding the applied load. The results for the R10480M this is not quite the case. The change in the measured value is greater from 15 to 20 Newtons than from 10 to 15 Newtons. Another interesting thing that is seen by observing the result in figure 5.2 is that the sensor does not instantaneous measure a constant value when a force is applied to the material. This may be because the force applied to it is not applied momentarily, but gradually. It is seen from the values measured when an applied force is removed that the material needs some time before it is completely returned to its original size.

During the initial tests, it was observed that the force gauge measured less force over time when compressing a material. This may be the most important result from the initial tests. As explained in section 5.1 it seemed like the material pushed back with less force over time. This suspicion was strengthened by the results of the tests using the spring scale. This behavior has probably lead to abnormal good results for the materials. The discovery of this stress relaxation in the materials also resulted in a need for a new test method. In addition to this the limitations of the force gauge by not measuring forces less than five Newtons, and the problems adjusting an accurate force only contributed to this need.

An ideal solution would have been a digital programmable force gauge which automatically adjusted the force it applied to the sensor. A tool like that could have been programmed adjust the force continuously, so the applied load had been constant. It would also open the opportunities for an advanced testbed, which could have tested the materials more in-depth. As a bonus, it would also minimize the probability of a human error while testing. Since such equipment was not available, a solution consisting of a test stand and independent weights was chosen instead.

## 6.2.2 The testing with weights

To continue the testing of the sensor and materials a test stand and weights was used. The idea behind these test was to gather data so a data model could be made. In addition to this the problems with stress relaxation detected by the initial tests could be further investigated.

### **R10480S - Metal weights**

The results from the first test of the R10480S with weights is found in figure 5.4. As seen in the figure there are a few outliers when compressing the force with 50, 200, and 500 grams. When creating the fitted curve, these points were removed from the data. Also the values measured with no load applied was removed. The few weights used to compress the material makes it difficult to be precise when discussing the fit of the data model. From the residual plot found in figure 5.7 it is seen that the actual values measured by the sensor is equally divided around the fitted curve. The range of measured values for the different weights make it difficult to create a good model for the data. The model would be highly uncertain due to the range of values. Ideally the residuals in figure 5.5 should be close to zero.

### **R10480S - Metal plates**

When using the metal plates to compress the materials more data was collected for creating a data model. Sensor values was recorded with weights of approximately 100 to 1000 grams compressing the material. An exponential model was fitted to the data. From 100 to 600 grams the fitted curve is approximately linear. From 600 to 1000 grams the curve begin to exponentially decay. This may indicate that there is some material properties that come into question when the material is compressed with more than 600 grams.

Using the residual plot it is visible that this fitted curve has the same problems as the one in discussed in the previous section. The actually values measured by the sensor deviates greatly from the predicted values for the data model.

Another thing that must be mentioned is that the values measured by the sensor when using the weights of 100, 200, and 500 grams does not match the corresponding values measured when using the metal plates. This is probably because the sensor is not isolated properly from the weights. The different metal alloys of the weights and the plates affect the dielectric seen by the sensor. This is the reason behind the focusing at the change in measured value, instead of the actual value. This is also the reason behind omitting the values measured with no applied load from the data models, as the change in measured value would be affected by the change of dielectric constant.

### **R10480S - Constant load**

The most interesting results came when compressing the R10480S with a constant load of 1460 grams. The result is seen in figure 5.8. The measured value decreases exponentially. The measured value decreases for over an hour before the samples gets close to a constant value. This demonstrates the problem of compression stress relaxation in the material. This behavior is only present when the material is compressed with a force above a certain threshold. A property like this in a material will limit the maximum force the sensor can measure.

When the constant load was removed the material returned to its original shape. This indicates that the compression set is low, as stated in the materials datasheet. The measured values increase exponentially when the weights are removed, and after approximately 40 minutes the sensor measures normal values. This proves that the sensor uses some time before returning to

its original size.

**R10480M - Metal weights** The results of testing the R10480M with metal weights is seen in figure 5.10. The results are similar to the same test performed with the R10480S. The main differences is the number of outliers, and the change in measured value for the different loads. For an unknown reason there are several more outliers for this test, and all of them are located below the other values measured. This is opposite of the case when the R1048M was tested with the force gauge. In that test the outliers, the measures before reaching a constant measure, was above the other values.

The fitted curve has the same problems as the other ones. The variation in measured values for one specific load is too high compared to the change in measured value when increasing the load. This makes it difficult using the model for predicting the value the sensor will measure for an applied load.

**R10480M - Metal plates** Since the R10480M needs more force to be compressed compared to the R10480S, the test using metal plates was extended up to about 2000 grams. The fitted curve is close to linear. The difference of this fit compared to the others is that most of the measured values is placed below the fitted curve. This is made visible by the residual plot found in figure 5.13. Using this model to estimate the sensor reading for some applied loads could be done. The main problems of the fit comes from the spread in measured values for loads of 400, 600, 800 and 1800 grams.

**R10480M - Constant load** The result of compressing the R10480M with a high constant load is seen in figure 5.14. It is clear that also R10480M suffer from compression stress relaxation. The measured value does not change as much as for the R10480S. If the applied load have been higher this may have changed. When the constant load was removed the material returned to its original shape, and the sensor measured normal values. This is similar as for the R10480S

### 6.2.3 The sensor solutions

After performing several tests using both the R10480S and R10480M, and analyzing the collected data it is clear that the chosen solution is not optimal for measuring force. It is mainly the inconsistency in the sensor measurements for the various loads that complicates the work finding an data model with a good fit. For both materials a new series of measurements, with the same applied load as in earlier tests, can cause the sensor to measure different values.

Another thing that complicates this solution is the placing of the material directly upon the sensor. This does not only change the dielectric constant measured by the sensor, but it also complicates the force measurements. Since the materials used are both soft and compressible, they are also prone to shear forces. During the testing it was necessary to be very cautious when applying a load to the sensor.

A solution that could solve this problem is another placing of the material. If the material is placed around the edges of a metal plate, a force could be applied to this plate, and the material would be compressed. The sensor would be placed under the plate and accurately measure the change in distance to it as the material got compressed. This would ease the operation of the sensor. It could also probably decrease the problem of stress relaxation, since the force compressing the material would be distributed to a larger area than 19x19 mm. This would

mean that the material would compress less for a specific force compared to the solution tested in this thesis. A sketch of how such a solution could look like is included in figure 6.1a.

A solution similar to the one used with the inductive sensor in chapter 3, would be to replace the compressible materials with springs. There are springs with known characteristics which could be used. This would also make it easier to decide which forces the sensor successfully could measure.

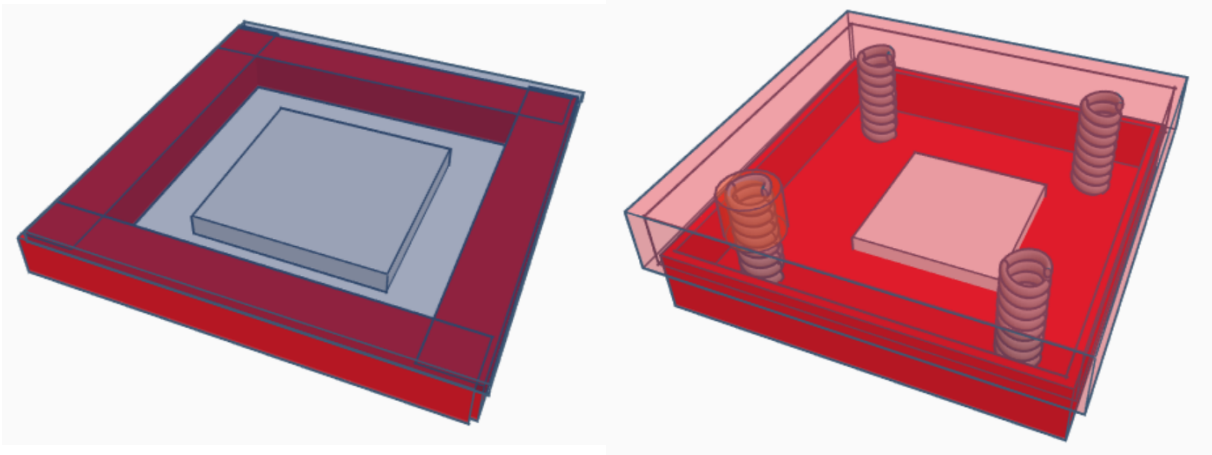

(a) An alternative solution.

(b) An alternative solution using springs

**Figure 6.1:** Sketches of alternative solutions



# Chapter 7

## Conclusion

This thesis has covered the work studying materials suitable for the intended application, the testing of these materials, and the evaluation of the sensor solution using these materials. In chapter 3 some interesting solutions using capacitive sensors and an inductive sensor for measuring force was presented. Even if these solutions differed from the one examined in in this thesis, they proved that the same principles can be used to accurately measure force.

After testing the Saint-Gobain NORSEAL<sup>®</sup> R10480S and the R10480M it proved difficult to create a data model that could successfully predict the sensor output, given the load applied to the material. As previously mentioned the first test method using the force gauge proved to be inadequate. Despite of this it revealed compression stress relaxation in the materials. The testing was developed further aiming for collecting useful data that could be used to create a good fitting data model. Several series of tests was performed with both materials. The results of this tests indicated that it would be difficult to create a data model for the sensor. The measured values varied to much for similar loads. This lead to the data models having a small probability for predicting the sensor value given the applied load.

It would have been interesting to test the sensor using different materials. The Bisco<sup>®</sup> BF-1000 and the Bisco<sup>®</sup> BF-2000 claimed to have high compressibility, very low compression set, and low stress relaxation. Testing these materials would have given the thesis more depth, by examining if they have the same weaknesses as the R10480S and R10480M. The compression stress relaxation discovered by the tests place a maximum limit at the force that can compress the materials.

If the materials had proven to be suitable for this application, additional testing would have been necessary. For these tests a new test method would be needed. A digital programmable force gauge that adjusts the force continuously would have been a good solution. The new tests must have, among other things, tested for hysteresis and the recovery time for the sensor after a compression. The resolution using the selected material would also have to be determined.

---

## 7.1 Further work

It is possible to take various paths to continue the work done in this thesis. One of them is to keep the current solution, where the material is mounted directly upon the sensor. This will require that the study after the optimal material is prioritized. By testing more materials it would be clearer if the solution presented in this thesis is possible.

Another solution that also requires that the study after materials continue, is the one illustrated in figure 6.1a. A compressible material could be attached at the edges, and under, a plate. The sensor would then be placed under this plate. The values the sensor then measure will be dependent on the distance to the plate. This distance will variate with the force applied to the plate and compressing the material.

The last path presented here will be to use springs instead of a compressible material. A sketch of how such a solution could be is seen in figure 6.1b. This approach is similar to both the solutions presented in chapter 3 and the previously presented solution.

# Bibliography

- [1] A. Abu\_Al\_Aish and M. Rehman. Development of a capacitive mass measuring system. *Sensors and Actuators A: Physical*, 151(2):113–117, 2009.
- [2] Advance Tapes International Limited. *AT525 35 Micron Copper Foil Shielding Tape Datasheet*. Version 4.
- [3] M. F. Ashby. *Materials Selection in Mechanical Design*. Elsevier, fourth edition, 2011.
- [4] L. K. Baxter. *Capacitive Sensors: Design and Applications*. Wiley-IEEE Press, 1996.
- [5] Disruptive Technologies. *THE WORLDS SMALLEST IOT SENSOR BREAKS PERFORMANCE BOUNDARIES*, 2018. <https://www.disruptive-technologies.com/>.
- [6] J. A. Dobrzynska and M. Gijs. Polymer-based flexible capacitive sensor for three-axial force measurements. *Journal of Micromechanics and Microengineering*, 23(1), 2012.
- [7] Grafana Labs. *Grafana*, 2018. <http://www.grafana.com/>.
- [8] L. Kirkby. *Physics: A Student Companion*. Scion, 2011.
- [9] H.-K. Lee, S.-I. Chang, and E. Yoon. A flexible polymer tactile sensor: Fabrication and modular expandability for large area deployment. *Journal of microelectromechanical systems*, 15(6):1681–1686, 2006.
- [10] Ø. Moldsvor. Private e-mail communication, 2018.
- [11] H. Motulsky and A. Christopoulos. *Fitting models to biological data using linear and nonlinear regression: a practical guide to curve fitting*. Oxford University Press, 2004.
- [12] Rogers Corporation. *Bisco BF-1000 - Extra Soft Cellular Silicone - Datasheet*. Publication 180-048.
- [13] Rogers Corporation. *Bisco BF-2000 - Ultra Soft Silicone - Datasheet*. Publication 180-049.
- [14] Rogers Corporation. *PORON 4701-30 Very Soft Datasheet*. Publication 17-006.
- [15] Saint-Gobain Performance Plastics. *NORSEAL R10480M(medium) - Datasheet*, 2015. SPE-5258-1015-SGCS.
- [16] Saint-Gobain Performance Plastics. *NORSEAL R10480S(soft) - Datasheet*, 2015. SPE-5198-1015-SGCS.
- [17] D. M. Stefanescu. *Handbook of force transducers: principles and components*. Springer Science & Business Media, 2011.
- [18] T-Global Technology Co. Ltd. *L37-5S Thermal Pad - Datasheet*, 2017. Version 4.
- [19] T-Global Technology Co. Ltd. *TG2030 Ultra Soft Thermal Pad - Datasheet*, 2017. Version 4.

- 
- [20] T-Global Technology Co. Ltd. *TG6050 Ultra Soft Thermal Pad - Datasheet*, 2017. Version 4.
- [21] E. Terzic, J. Terzic, R. Nagarajah, and M. Alamgir. Capacitive sensing technology. In *A Neural Network Approach to Fluid Quantity Measurement in Dynamic Environments*, pages 11–37. Springer, 2012.
- [22] Texas Instruments. *Distance and Weight Measurement Using Inductive Sensing Reference Design*, June, 2014.
- [23] Texas Instruments. *LDC1041 - Datasheet*, March, 2014. SNOSCY1.
- [24] The Mathworks, Inc. *Matlab R2017b*, 2017. <https://se.mathworks.com/products/matlab.html>.
- [25] The Mathworks, Inc. *Matlab: Curve Fitting Toolbox*, 2018. [https://se.mathworks.com/help/pdf\\_doc/curvefit/curvefit.pdf](https://se.mathworks.com/help/pdf_doc/curvefit/curvefit.pdf).
- [26] Wikimedia Commons - User: Nicoguardo. *File:Young vs density-loglog.svg*, 2018. [https://en.wikipedia.org/wiki/File:Young\\_vs\\_density-loglog.svg](https://en.wikipedia.org/wiki/File:Young_vs_density-loglog.svg).