



Norwegian University of
Science and Technology

Thermal comfort and energy use for cooling and heating in non-residential buildings

Stina Skeie

Master of Energy and Environmental Engineering

Submission date: June 2018

Supervisor: Hans Martin Mathisen, EPT

Co-supervisor: Maria Justo Alonso, EPT

Nicola Lolli, EPT

Norwegian University of Science and Technology

Department of Energy and Process Engineering

EPT-M-2018-82

MASTER THESIS

for

Student Stina Skeie

Spring 2018

*Thermal comfort and energy use for cooling and heating in non-residential buildings**Termisk komfort og energibruk for kjøling og oppvarming i yrkesbygg***Background and objective**

Mechanical cooling of buildings require large amounts of energy. Also cooling with increased flow rates of outdoor air might increase the energy use for operation of fans.

New research reports a clear dependence of indoor comfort temperatures on outdoor air temperatures especially in buildings that are free-running or naturally ventilated. Many of these studies have been done in warm and moderate climate zones. The idea behind this master work is to study if this also applies for colder climates. If so, energy for transport of air could be reduced.

This project work will be part of the newly started research centre FME ZEN.

(www.ntnu.no/zen)

SINTEF Building and Infrastructure has a ongoing research project where the connection between ventilation solutions and perceived indoor quality is measured. The test are done in ZEB Test Cell where different experiments are done simultaneously in two small rooms.

The objective of the master thesis is to investigate to what extent in colder climate it is possible to exploit that the acceptable indoor temperature is affected by the controllability of the indoor environment following the adaptive thermal comfort theory. The problem applies both in heating season and at higher outdoor temperatures.

The work is a continuation of the candidate's Specialization project.

The following tasks are to be considered:

1. The literature study conducted in the specialization project should be updated.
2. Collaboration regarding data collection and analysis with the experiments conducted at SINTEF's project SkinTech. The candidate analyses thermal comfort and SkinTech the indoor environment.
3. Analyse the data with regard to thermal comfort and air quality, develop models for acceptability of thermal comfort based on the analysis of measurements and answers to the questionnaire delivered during the SkinTech experiments.

4. Use the IDA ICE model developed in the project work to analyse the effect on energy use of different acceptability rates.
5. Discuss the results and draw conclusions in relation to the objective of the project.

-- ” --

Within 14 days of receiving the written text on the master thesis, the candidate shall submit a research plan for his project to the department.

When the thesis is evaluated, emphasis is put on processing of the results, and that they are presented in tabular and/or graphic form in a clear manner, and that they are analyzed carefully.

The thesis should be formulated as a research report with summary both in English and Norwegian, conclusion, literature references, table of contents etc. During the preparation of the text, the candidate should make an effort to produce a well-structured and easily readable report. In order to ease the evaluation of the thesis, it is important that the cross-references are correct. In the making of the report, strong emphasis should be placed on both a thorough discussion of the results and an orderly presentation.

The candidate is requested to initiate and keep close contact with his/her academic supervisor(s) throughout the working period. The candidate must follow the rules and regulations of NTNU as well as passive directions given by the Department of Energy and Process Engineering.

Risk assessment of the candidate's work shall be carried out according to the department's procedures. The risk assessment must be documented and included as part of the final report. Events related to the candidate's work adversely affecting the health, safety or security, must be documented and included as part of the final report. If the documentation on risk assessment represents a large number of pages, the full version is to be submitted electronically to the supervisor and an excerpt is included in the report.

Pursuant to “Regulations concerning the supplementary provisions to the technology study program/Master of Science” at NTNU §20, the Department reserves the permission to utilize all the results and data for teaching and research purposes as well as in future publications.

The final report is to be submitted digitally in DAIM. An executive summary of the thesis including title, student's name, supervisor's name, year, department name, and NTNU's logo and name, shall be submitted to the department as a separate pdf file. Based on an agreement with the supervisor, the final report and other material and documents may be given to the supervisor in digital format.

- Work to be done in lab (Water power lab, Fluids engineering lab, Thermal engineering lab)
 Field work

Department of Energy and Process Engineering, 15. January 2018



Hans Martin Mathisen
Academic Supervisor

Research Advisers:
Maria Justo Alonso
Nicola Lolli

PREFACE

This master's thesis has been written at NTNU and the Department of Energy and Process Engineering. The work was completed during the spring semester of 2018, and is a continuation of the specialization project from the previous semester. The author is a student at the university, attending the study program Energy and Environmental Engineering.

I would like to thank my academic supervisor, professor Hans Martin Mathisen, and my research advisers Maria Justo Alonso and Nicola Lolli. This past semester they have given me continuous guidance. I have truly learned a lot during this process. I would also like to thank Maria Justo Alonso and Nicola Lolli for introducing me to the experimental work in correlation to the research project SkinTech, and both Alessandro Nocente and Johannes Georg Brozovsky for answering every question related to the work at the ZEB Test Cell Laboratory.

Trondheim, 11. June 2018

Stina Skeie

Stina Skeie

ABSTRACT

Indoor environmental quality is important as 90% of time is spent indoors. Otherwise consequences can be reduced performance of work or fostered illnesses. Contrary, the building sector is responsible for 40% of the total energy use in the world. There is a need for measures with immediate effect. This thesis examines user controllability of the indoor environment in correlation to thermal comfort and energy use. It is of interest as energy performance of buildings is suggested to be influenced by user behaviour. Field work was carried out at the ZEB Test Cell Laboratory in Trondheim and simulations completed in IDA ICE. Accordingly, this thesis is a contribution to the field of research covering a cold climate. Experiments gathering measurements and questionnaires were carried out simultaneously in two separated but identical office cells, automatic and manually operated, with one occupant in each cell. The experiment was based on a low number of participants due to being postponed until May. Hence, no general conclusions could be drawn. Although, comparing findings to relevant literature showed reappearing trends.

Key findings showed a difference in thermal sensation votes. The occupant in the manual cell perceived the thermal environment as neutral, whereas the participant in the automatic cell voted slightly warm throughout large portions of the relevant day. Accordingly, the participant in the automatic cell rated temperatures above 25.6°C just acceptable whilst the occupant in the manual cell perceived the temperature as clearly acceptable throughout the entire day with the highest temperature at 25.9°C. This resulted in a difference in perceived maximal temperature of 0.3°C. Deviations could be due to operating strategies. User control ensures that occupants more actively can optimize conditions directly based on individual preferences. Simulations were completed on the case day calculating standard comfort indices in accordance with Fanger's model. Concurrence between calculated and observed votes were most evident for the computer operated cell. Standard calculations failed to predict thermal sensation for the manual cell. Votes were not slightly cool as calculated in IDA ICE, but in reality neutral and slightly warm.

User behaviour and its effect on energy use was researched by simulating four window opening strategies in IDA ICE. That is 1) always open, 2) never open, 3) based on season, indoor and outdoor temperature and CO_2 and 4) as registered during experiments in the manual cell. The greatest difference in heating consumption resulted in a percentage change of 499% between strategy 1) and 4). A lower percentage change at 192% was found when comparing strategy 3) and 4). Fixed setpoints were applied for the radiator when modelling all four strategies. In reality occupants are assumed to turn off the radiator thermostat if windows are opened and not pursue a conflicting operating strategy as modelled.

Multivariable regression analysis in Excel showed that window opening events in the manual cell were correlated to operative temperature, outdoor temperature, CO_2 level and solar radiation with the following model. The parameters explain 78% of the variability in window opening percentage. The outdoor climatic parameters resulted in the lowest probability values and accordingly higher significance.

$$y = -207.25 + 4.67 * T_{op} + 2.74 * T_{out} + 0.14 * CO_2 + 0.04 * I_{rad}$$

SAMANDRAG

Eit godt inneklima er viktig då ein 90% av tida oppheld seg innandørs. I anna fall kan konsekvensar vera redusert arbeidsyting eller helseplager. Motsett er bygningssektoren ansvarleg for 40% av den totale energibruken i verda. Det er eit behov for tiltak med umiddelbar verknad. Denne masteroppgåva undersøker brukaren sin fridom til å kontrollera inneklimaet i samband med termisk komfort og energibruk. Dette er av interesse då ytelsen til bygningar verkar å vera påverka av brukaråtferd. Feltarbeid har vorte gjennomført i ZEB Test Cell Laboratory i Trondheim samt simuleringar i IDA ICE. Høvesvis er oppgåva eit bidrag til forskningsfeltet ved å dekkja eit kaldt klima. Eksperiment der både målingar og spyrjeundersøkingar vart innhenta, blei gjennomført samtidig i to separate, men identiske kontorceller, automatisk og manuelt styrt, med ein brukar i kvart rom. Eksperimentet har vorte basert på fåe deltakarar då forsøka vart utsett til mai. Soleis kan ingen generelle konklusjonar trekkjast. Likevel samsvara resultatata med funn frå relevant litteratur.

Hovudfunna avslørte skilnadar i termisk vurdering. Deltakaren i den manuelle cella oppfatta det termiske miljøet som nøytralt, medan deltakaren i den automatiske cella var lett varm store delar av den aktuelle dagen. Tilsvarende vurderte deltakaren i den automatiske cella temperaturar over 25.6°C som akkurat akseptabel medan personen i den manuelle, oppfatta temperaturen som klart akseptabel gjennom heile dagen der den høgaste temperaturen var 25.9°C. Dette resulterte i ein skilnad i oppfatta maksimal temperatur på 0.3°C. Avvik kan skuldast styringsstrategiane. Brukarkontroll sikrar at ein meir aktivt kan optimalisera forholda direkte basert på individuelle preferansar. Simuleringar vart fullført for den aktuelle dagen og standard komfort indeksar kalkulert i henhold til Fanger sin modell. Einstemme mellom beregna og observerte verdiar var mest tydeleg for den datastyrt cella. Standard beregningar feila i å forutsjå termisk vurdering for den manuelle cella. Evalueringa var ikkje lett kjølig som kalkulert i IDA ICE, men heller nøytral og lett varm.

Effekta brukaråtferd har på energibruk vart undersøkt ved å simulera fire vindaugeopningsstrategiar i IDA ICE. Desse var 1) alltid ope, 2) aldri ope, 3) basert på årstid, inne- og utetemperatur og CO_2 og 4) som registrert under eksperimentet i den manuelle cella. Den største skilnaden i oppvarmingsforbruk resulterte i ei prosentvis endring på 499% for strategi 1) og 4). Ei lågare prosentvis endring på 192% vart funne ved å samanlikna strategi 3) og 4). Faste settpunkt vart nytta for radiatoren ved modellering av alle fire strategiar. I røynda er det antake at deltakarane ville ha slått av termostaten på radiatoren dersom vindaugene vart opna og ikkje fylgt ein motstridande styringsstrategi som den modellert.

Fleirvariabel regresjonsanalyse i Excel viste at vindaugeopning i den manuelle cella kan knyttast til operativ temperatur, utetemperatur, CO_2 nivå og solstrålingsintensitet med den fylgjande modellen. Parameterna forklarar 78% av variasjonen i prosent vindaugeopning. Uteklimateparameterna resulterte i dei lågaste p-verdiane og vart henholdsvis rekna som dei mest betydelege.

$$y = -207.25 + 4.67 * T_{op} + 2.74 * T_{out} + 0.14 * CO_2 + 0.04 * I_{rad}$$

CONTENTS

List of Figures	i
List of Tables	iv
Abbreviations	v
List of Symbols	vi
1. Introduction	1
1.1. Background	1
1.2. Objective	2
1.2.1. Research questions	3
1.3. Method of work	3
1.4. Report structure	4
2. Literature review	5
2.1. Indoor environment	5
2.2. An introduction to thermal comfort	6
2.3. Standard model on thermal comfort	7
2.3.1. Fanger’s PMV and PPD model	7
2.3.2. Mayer’s modifications to Fanger’s model	10
2.3.3. A critical overview of the standard model	11
2.4. Adaptive thermal comfort	12
2.4.1. Adaptive control algorithm	13
2.4.2. Adaptive approach as included in the ASHRAE standard 55	14
2.4.3. Adaptive approach as included in the NS-EN 15251 standard	17
2.4.4. A customized Chinese standard	17
2.4.5. A critical overview of the adaptive approach	18
2.5. Alliesthesia	20
2.5.1. Temporal alliesthesia	21
2.5.2. Spatial alliesthesia	22
2.5.3. A critical overview of alliesthesia	23
2.6. Acceptability models of thermal comfort	24
2.7. Occupant behaviour and user controllability	27
2.7.1. Effects on energy use	29
2.8. Relevance of research	29
3. Field work at ZEB Test Cell Laboratory	31
3.1. FME ZEN	31
3.2. SkinTech	31
3.3. ZEB Test Cell Laboratory	32
3.4. Method of experimental work	33
3.4.1. Time period	33

3.4.2.	Procedure	33
3.4.3.	Measurement and test cell setup	35
3.4.4.	Calibration of anemometers	40
3.4.5.	Questionnaire	42
3.4.6.	Participants	42
4.	Simulations of the test cell	44
4.1.	Input data test cell model	44
4.1.1.	Location and climate	45
4.1.2.	Building body	45
4.1.3.	Key data	48
4.1.4.	Cite shading	49
4.2.	Control strategies	50
4.2.1.	Test Cell A	50
4.2.2.	Test Cell B	51
4.3.	Simulation case based on registered user behaviour	53
4.3.1.	Test Cell A	53
4.3.2.	Test Cell B	55
4.4.	User behaviour effects on energy use	56
4.4.1.	Window opening of the NorDan pane	57
4.4.2.	Modeled user behaviour	61
5.	Results and discussion	69
5.1.	Planned evaluation of results	69
5.2.	Field work at ZEB Test Cell Laboratory	71
5.2.1.	User controllability and thermal satisfaction	71
5.2.2.	Limitations of the experiment	83
5.3.	Simulations of the test cell	86
5.3.1.	Comfort results based on registered user behaviour	86
5.3.2.	User operated window control	93
5.3.3.	Limitations of the simulations	95
5.3.4.	Validation of the simulation models	96
5.4.	Regression analysis of window opening events	99
6.	Conclusion	103
7.	Further work	105
	Bibliography	107
	Appendix A. Measuring equipment field work	112
	Appendix B. Calibration of the anemometers	116
	Appendix C. User experiment questionnaire	122
	Appendix D. Risk assessment	125

LIST OF FIGURES

2.1.	PPD as a function of PMV, Ref.:(Norsk Standard, NS-EN ISO 7730 2006).	8
2.2.	PPD as a function of PMV for both Fanger and Mayer’s models, Ref.:(Hellwig et al. 2006).	10
2.3.	A graphical overview of adaptive comfort mechanisms, Ref.:(Li et al. 2012).	13
2.4.	Observed and predicted comfort temperatures for HVAC buildings, Ref.:(Brager and De Dear 2001).	15
2.5.	Observed and predicted comfort temperatures for natural ventilation, Ref.:(Brager and De Dear 2001).	15
2.6.	Acceptable operative temperatures for the NS-EN 15251 adaptive approach, Ref.: (Norsk Standard, NS-EN 15251 2014).	17
2.7.	Results from Mower’s field study showing an example of thermal alliesthesia, Ref.: (Parkinson and Dear 2015).	22
2.8.	Acceptability models based on type of ventilation, Ref.:(Hellwig et al. 2006).	24
2.9.	Acceptability models for naturally ventilated buildings based on season, Ref.:(Hellwig et al. 2006).	25
2.10.	Acceptability models based on perceived control, Ref.:(Hellwig et al. 2006).	26
3.1.	South facade of the ZEB Test Cell Laboratory. Photo: Stina Skeie.	32
3.2.	Left: External surface from south. Right: Floor plan of the building, Ref.: (Goia et al. 2017).	33
3.3.	Exterior of the cell. Photo: Stina Skeie.	34
3.4.	Inside the test cell. Photo: Stina Skeie.	34
3.5.	Simple sketch of the office space. Photo: Stina Skeie.	35
3.6.	Detailed sketch of the test cell window by NorDan. Viewed from the exterior.	35
3.7.	An example of a picture taken by the web camera showing occupancy. Photo: Stina Skeie.	36
3.8.	Tripod setup with sensors measuring air velocity, air- and radiant temperature. Photo: Stina Skeie.	38
3.9.	Closeup of the anemometer and Pt100. Photo: Stina Skeie.	38
3.10.	Setup of sensors measuring CO_2 , relative humidity and surface temperature. Photo: Stina Skeie.	39
3.11.	LabVIEW interface showing sensors for test cell A.	39
3.12.	TSI calibrator model 1125. Photo: Stina Skeie.	41
3.13.	Manometer. Photo: Stina Skeie.	41
4.1.	3D model showing the test cell as implemented in IDA ICE.	44
4.2.	Floor plan of the test cell as it appears in the IDA ICE model.	45
4.3.	Aerial photo of the ZEB Test Cell Laboratory and nearby surroundings, Ref.: (<i>Google Maps</i>).	49
4.4.	Cite shading as implemented in IDA ICE.	50
4.5.	Top window opening strategy control as implemented in IDA ICE.	52
4.6.	External shading screen draw control as implemented in IDA ICE.	52

4.7. Schedule for occupancy in test cell A.	54
4.8. Schedule for opening of the top window in test cell A.	54
4.9. Schedule for opening of the bottom window in test cell A.	54
4.10. Schedule for desk light in test cell A.	54
4.11. Schedule for room light in test cell A.	54
4.12. Schedule for shading screen in test cell A.	55
4.13. Schedule for occupancy in test cell B.	55
4.14. Schedule for desk light in test cell B.	55
4.15. Occupancy manual cell 30.04.18.	56
4.16. Occupancy manual cell 01.05.18.	57
4.17. Occupancy manual cell 02.05.18.	57
4.18. Occupancy manual cell 03.05.18.	57
4.19. Occupancy manual cell 04.05.18.	57
4.20. Window part <i>da</i> with both opening strategies; side hung casement to the left and bottom hung at the right. Photo: Stina Skeie.	58
4.21. Window part <i>aa</i> opening strategy; bottom hung. Photo: Stina Skeie.	58
4.22. Sensors registering window opening marked with the red boxes. Photo: Stina Skeie.	59
4.23. Closeup of the window opening sensor. Photo: Stina Skeie.	59
4.24. Schedule implemented in IDA ICE representing window opening strategy 1 30.04.18.	62
4.25. Schedule implemented in IDA ICE representing window opening strategy 1 01.05.18.	62
4.26. Schedule implemented in IDA ICE representing window opening strategy 1 02.05.18.	62
4.27. Schedule implemented in IDA ICE representing window opening strategy 1 03.05.18.	62
4.28. Schedule implemented in IDA ICE representing window opening strategy 1 04.05.18.	63
4.29. Window control as implemented in IDA ICE.	65
4.30. Window control as it appears in the macro for winter operation in IDA ICE.	65
4.31. Bottom window operation 30.04.18.	67
4.32. Bottom window operation 01.05.18.	67
4.33. Bottom window operation 02.05.18.	67
4.34. Bottom window operation 03.05.18.	67
4.35. Bottom window operation 04.05.18.	68
4.36. Top window operation 02.05.18.	68
4.37. Top window operation 03.05.18.	68
5.1. Optimal operative temperature in regards to activity- and clothing level, Ref.: (NTNU SINTEF 2007).	69
5.2. Thermal sensation during the day as rated by both occupants. Data gath- ered from 30.04.18.	72
5.3. Operative temperature at the time where questionnaires were completed. Data gathered from 30.04.18.	72
5.4. Outdoor temperature at the time where questionnaires were completed. Data gathered from 30.04.18.	73
5.5. Measured solar radiation at the time where questionnaires were completed. Data gathered from 30.04.18.	73

5.6. Thermal comfort level as rated at the end of the current workday. Data gathered from 30.04.18.	76
5.7. Perception of temperature. Data gathered from 30.04.18.	77
5.8. The CO_2 level in correlation to the event of window opening. Data gathered from 30.04.18.	80
5.9. Operative temperature in correlation to the event of window opening. Data gathered from 30.04.18.	82
5.10. Population pyramid showing the composition of the Norwegian population in terms of gender and age, Ref.: (StatisticsNorway 2018).	83
5.11. Fanger’s comfort index for test cell A as calculated in IDA ICE. Data gathered from 30.04.18.	87
5.12. Operative temperature during the day in cell A as calculated in IDA ICE. Data gathered from 30.04.18.	87
5.13. Measured operative temperature during the day in cell A. Data gathered from 30.04.18.	88
5.14. Fanger’s comfort index for test cell B as calculated in IDA ICE. Data gathered from 30.04.18.	89
5.15. Operative temperature during the day in cell B as calculated in IDA ICE. Data gathered from 30.04.18.	89
5.16. Measured operative temperature during the day in cell B. Data gathered from 30.04.18.	90
5.17. Thermal sensation votes correlated to measured operative temperature. Data gathered from 30.04.18.	91
5.18. CO_2 level measured in test cell A and B. Data gathered from 30.04.18. . . .	96
5.19. CO_2 level calculated in IDA ICE for test cell A. Data gathered from 30.04.18.	97
5.20. CO_2 level calculated in IDA ICE for test cell B. Data gathered from 30.04.18.	97
A.1. Sensor measuring air temperature.	112
A.2. Thermocouple sensor measuring surface temperature.	112
A.3. Thermocouple black ball measuring the radiant temperature.	113
A.4. Sensor measuring light level.	113
A.5. Sensor measuring the relative humidity.	114
A.6. Sensor measuring the CO_2 level.	114
A.7. Anemometer measuring air velocity.	115
B.1. Calibration data for anemometers installed in the automatic test cell.	117
B.2. Calibration data for anemometers installed in the manual test cell.	118
B.3. Regression analysis on calibration data for anemometer A.ANEM2.	119
B.4. Regression analysis on calibration data for anemometer A.ANEM3.	119
B.5. Regression analysis on calibration data for anemometer A.ANEM4.	119
B.6. Regression analysis on calibration data for anemometer B.ANEM2.	120
B.7. Regression analysis on calibration data for anemometer B.ANEM3.	120
B.8. Regression analysis on calibration data for anemometer B.ANEM4.	120
B.9. Best linear fit and correlated deviations.	121
B.10.Raw data as included in LabVIEW correlating voltage to velocity.	121

LIST OF TABLES

2.1. Categories defining thermal comfort acceptability according to NS-EN 15251.	9
2.2. Design criteria for comfort indices by NS-EN ISO 7730.	9
2.3. Allowed deviation on indoor parameters as recommended in NS-EN 15251.	10
2.4. Adaptive control algorithms for Europe and individual countries of relevance.	14
3.1. Control strategies defining test cell operation.	34
3.2. Measured outputs to be gathered in the two test cells.	37
3.3. Participants of the case study.	43
3.4. Overview showing arrangement of participants for different parts of the study.	43
4.1. Properties for the construction of internal walls and ceiling slab, Ref.: (Cattarin et al. 2017).	46
4.2. Properties for the construction of internal floor, Ref.: (Cattarin et al. 2017).	46
4.3. Properties for the construction of external wall faced south, Ref.: (Cattarin et al. 2017).	47
4.4. Properties for the construction of the window element.	47
4.5. Properties for the test cell window element.	48
4.6. Key data implemented in the simulation model.	49
4.7. Control strategies for test cell A.	51
4.8. Control strategies for test cell B.	51
4.9. Key data for the participant in test cell A.	53
4.10. Key data for the participant in test cell B.	55
4.11. Clothing insulation value as implemented in IDA ICE.	56
4.12. Window opening area for strategy 1.	62
4.13. Bottom window opening area for strategy 3.	64
4.14. Top window opening area for strategy 3.	64
4.15. Percentage of window opening for the two different opening methods.	66
4.16. Window opening area for strategy 4.	67
5.1. Design values for operative temperature according to NS-EN 15251.	70
5.2. Number of registered actions of user behaviour in cell A as a result of responses to the questionnaires. Data gathered from 30.04.18.	79
5.3. Number of registered actions missed by the occupant in cell B as a result of responses to the questionnaires. Data gathered from 30.04.18.	79
5.4. Results showing user behaviour effects on heating consumption and IEQ. Data gathered from 30.04.18-04.05.18.	93
5.5. Registered scenarios where the user opened a part of the window in cell A. Data gathered from 30.04.18-04.05.18.	100
5.6. Regression statistics.	101
5.7. Degrees of freedom.	101
5.8. Summary outputs on coefficients.	101

ABBREVIATIONS

NTNU	Norwegian University of Science and Technology
FME ZEN	The Research Centre on Zero Emission Neighbourhoods in Smart Cities
ZEB	The Research Centre on Zero Emission Buildings
IDA ICE	IDA Indoor Climate and Energy
ECTS	European Credit Transfer and Accumulation System
IEQ	Indoor Environmental Quality
SINTEF	The Foundation for Scientific and Industrial Research
LabVIEW	Laboratory Virtual Instrument Engineering Workbench
PPD	Predicted Percentage of Dissatisfied
PMV	Predicted Mean Vote
ASHRAE	American Society of Heating Refrigerating and Air-conditioning Engineers
HVAC	Heating, Ventilation and Air Conditioning
aPMV	Adaptive Predicted Mean Vote model
ACA	Adaptive Control Algorithm
CAV	Constant Air Volume

LIST OF SYMBOLS

clo	- thermal resistance of clothing	- $[0.155m^2K/W]$
met	- metabolic rate. Depending on activity level	- $[58W/m^2]$
T_{comf}	- comfort temperature	- $[^{\circ}C]$
$T_{a,out}$	- monthly mean outdoor air temperature	- $[^{\circ}C]$
T_{RM}	- running mean outdoor temperature	- $[^{\circ}C]$
λ	- adaptive coefficient	- $[-]$
W	- width	- $[m]$
L	- length	- $[m]$
H	- height	- $[m]$
a	- tilt width of window opening	- $[m]$
α	- degree of window opening	- $[^{\circ}]$
c_d	- discharge coefficient	- $[-]$
$A_{opening}$	- area of window opening	- $[m^2]$
A_{eff}	- effective area of window opening	- $[m^2]$
T_{op}	- operative temperature	- $[^{\circ}C]$
T_a	- air temperature	- $[^{\circ}C]$
T_{mr}	- mean radiant temperature	- $[^{\circ}C]$
v	- air velocity	- $[m/s]$
y	- regression response variable	- $[-]$
β_k	- regression coefficients	- $[-]$
x_k	- regression explanatory variables	- $[-]$
R^2	- coefficient of determination	- $[-]$
k	- number of coefficients	- $[-]$
n	- number of observations	- $[-]$
I_{rad}	- solar radiation	- $[W/m^2]$
T_{out}	- outdoor temperature	- $[^{\circ}C]$

1. INTRODUCTION

The aim of the introduction is to present the work to be completed in this master's thesis in terms of objective and methodology. Some background literature is included in order to show relevance of the work.

1.1. BACKGROUND

People spend more than 90% of their time indoors (NTNU SINTEF 2007, page 102), either at home, at work or school, or when doing recreational activities. This implies that it is of great importance to give attention to the indoor environment when designing a building. Poor indoor environmental quality, IEQ, can reduce performance of work, foster several different respiratory illnesses, allergies and headache (Fisk 2000). On the other hand, the building sector is responsible for 40% of the total energy use in the world (NTNU SINTEF 2007, page 18). From an environmental friendly perspective this high energy use need to be reduced (Arens et al. 2010). This applies to new buildings and also concerns renovation of existing buildings. There is a need for measures with immediate effect. Energy used for ventilation and ensuring a good indoor climate represents a large amount of this total energy use (Ingebrigsten 2017a, page 112). The aim should be to achieve good IEQ and simultaneously keep the energy use as low as possible, implying that a crossing point between high IEQ and low energy use should be strived. As an example, unnecessary heating and air conditioning should be minimized (Arens et al. 2010).

Newer research has shown a dependence of indoor temperatures perceived as comfortable on outdoor air temperatures (Sourbron and Helsen 2011; Halawa and Van Hoof 2012). This is of great relevance to buildings that are free-running or naturally ventilated. Such buildings are more connected to the outdoor climate. Indoor spaces are then ventilated due to natural driving forces through for example windows or vents, as opposed to a closed off environment of a fully mechanically ventilated building. If the outdoor climate could affect the indoor environment to a greater extent, the energy for transportation of air could be reduced. That is as the mechanical ventilation system is partly- or fully replaced by for example window operation. Furthermore, if the indoor conditions are tracking the outdoor more closely, there is no need to activate the cooling- or heating system in order to resist the smallest variations in temperature.

This master's thesis is completed at NTNU and provided by the Department of Energy and Process Engineering. It is a part of the course TEP4935, Energy Planning and Environmental Analysis Master's Thesis. The thesis comprises 30 ECTS credits, and was written during the spring semester of 2018. The estimated time frame was 21 weeks accounting for one extra week due to Easter.

1.2. OBJECTIVE

This thesis will examine user controllability of the indoor environment following the adaptive thermal comfort theory. The overall objective is disassembled with the research questions presented in the following section, Chapter 1.2.1.

SINTEF Building and Infrastructure has an ongoing research project named SkinTech. Measurements on thermal comfort will be completed at the ZEB Test Cell Laboratory in Trondheim utilizing both installed sensors and questionnaires (*Test Cell Laboratory*). Experiments will be carried out simultaneously in two separated but identical rooms having one occupant present in each cell. The two test cells will be manually and automatically operated respectively. A part of the work for this thesis will be in collaboration with the experimental work at the ZEB Test Cell Laboratory regarding data collection and analysis. Thermal comfort will be analyzed as well as the indoor environment.

It is of interest to analyze the presence and demand of user controllability of the indoor environment, as user behaviour and occupant demands and expectations seem to be of significant influence (Andersen et al. 2009; Gartland et al. 1993). The energy performance of a building seem to be highly influenced by user behaviour (Andersen et al. 2009). Examples include opening and closing of windows and setting of room thermostat. Furthermore, occupants having the possibility to control their indoor environment seem to be more satisfied as well as allowing a greater variation of temperatures (Toftum 2010). Building users will then accept some degree of discomfort as they are provided with effective means to restore thermal comfort if they should choose to act. This is of great relevance to the challenges regarding energy savings and environmental issues the world is facing today.

Due to a delay in the startup date for the experimental work at the ZEB Test Cell Laboratory, only a week worth of data will be gathered and used when presenting the results. The start up date was postponed several times until May, originally planned to take place in February. The field work in the lead of SINTEF continued for another three weeks, but in order to maintain the progress plan of a thesis this was decided to be the best solution. Hence, the further research will be regarded as a case study where no general conclusions can be drawn.

The low number of participants due to the delay resulted in a needed change of research tasks. The initial aim was to develop an acceptability model of thermal comfort based on the analysis of measurements and answers to the questionnaires completed during the experiment at the ZEB Test Cell Laboratory. The acceptability model and its effect on energy use was to be analyzed in IDA ICE. These tasks are referred to as number 3 and 4 on the assignment text as given in the very beginning of this report. In agreement with the supervisors it was decided that a suitable solution was to slightly change the objective of this thesis. It would be of no interest to develop an acceptability model only based on one week of data and three participants. The data is still to be analyzed with regards to thermal comfort and air quality. However, the main focus will be user controllability. By gathering data and occupant feedback user controllability should be analyzed in terms of perception of comfort and PMV. Furthermore, window opening strategies will be given further attention when analyzing the effects user feasibility to control indoor environmental parameters has on energy use for heating.

1.2.1. RESEARCH QUESTIONS

The following research questions define the objective of the work and will be answered in this master's thesis.

- *Do the participants of the case study rate thermal sensation differently when the zone is automatically optimized providing no user controllability, or when occupants have the possibility to affect the control strategies?*
- *To what extent is the occupants' acceptable indoor temperature affected by the user feasibility to control the indoor environment?*
- *Do the participants of the case study represent a standard vote in correlation to the PMV model?*
- *To what extent is the energy consumption for heating affected by user behaviour?*

1.3. METHOD OF WORK

The method of work will be tripartite and consists of a literature study, field work and simulations. The literature study conducted in the student's previous specialization project from 2017 will be updated. Resources to be used are journal databases, subject specific professional websites and books of relevance. Some key words for further research are thermal comfort, adaptive thermal comfort models, energy use, cold climates, user controllability, user behaviour, field study etc.

The same applies for the simulation as a simplified model of a cell office was developed during the work of the specialization project. This model will be updated in order to represent the setup for the experimental work at the ZEB Test Cell Laboratory in Trondheim. The simulation tool to be used is IDA ICE version 4.7.1 developed by EQUA. A further explanation as to why IDA ICE has been the simulation tool of choice is given in Skeie's specialization project (Skeie 2017). The aim of the simulation is to analyze acceptability of thermal comfort in terms of user preferences and feasibility to control the indoor environment. The comfort index of PMV should be determined accordingly. Furthermore, user behaviour will be studied in correlation to energy use by simulating different window opening strategies. One of the models for window operation will be developed based on a cross cut analysis between measurements by sensors and occupant feedback from questionnaires gathered during the SkinTech experiments.

As similar studies for most parts have been completed in warm or moderate climates it is of interest to research suitability of adaptive thermal comfort for a colder climate. In this master's thesis this is represented with the climate of Trondheim in Norway, further described in Skeie's project work from 2017 (Skeie 2017).

1.4. REPORT STRUCTURE

The main section of this report is initiated with a literature review. This is presented in Chapter 2 and includes theory on thermal comfort models and user behaviour effects on energy use. The two following sections, Chapter 3 and 4, aims to introduce the experimental work and simulations respectively. A common presentation of results and discussion has been regarded as the most sufficient solution. That is in order to give a clear and structural overview of important findings. Thus both results and discussion are given in Chapter 5. Then a summarizing conclusion follows in Chapter 6 and ideas for further work in Chapter 7.

2. LITERATURE REVIEW

The purpose of this literature review is to build a framework for the following research to be done as field work and simulation. Literature is gathered in order to show the current state of existing research and simultaneously show the relevance of this master's thesis. It will act as a background for making decisions during the practical work. This chapter is to some extent based on the literature study conducted in Skeie's specialization project from 2017 *Thermal comfort and energy use for cooling and heating in non-residential buildings*. The literature review that follows is an updated version containing relevant literature from the specialization project as well as additions in accordance with the objective of this master's thesis.

2.1. INDOOR ENVIRONMENT

When designing a building, the indoor climate is of great importance in terms of well being of the occupants, providing an environment that ensures good indoor conditions and health. Where health is *a state of complete physical, mental, and social well-being and not merely the absence of disease or infirmity*, as defined by the World Health Organization. Furthermore, indoor climate is a collective term including the five main elements listed below (Ingebrigsten 2017b, page 82):

- Thermal environment
- Atmospheric environment
- Acoustic environment
- Mechanical environment
- Actinic environment

Occupants are also affected by the two environments listed below (Ingebrigsten 2017b, page 82):

- Aesthetic environment
- Psychosocial environment

As a whole these seven factors represent the indoor environment. In correlation to the field work, the indoor environment should be analyzed in regards to the thermal- and atmospheric environment. The thermal environment is relevant in relation to thermal comfort, whilst the atmospheric environment is of great importance in terms of quality of indoor air. Therefore, these are given further attention.

The thermal environment is affected by air temperature, vertical temperature gradients, radiant temperature, air velocity and relative humidity (Ingebrigsten 2017b, page 82). Perception of the thermal environment is also affected by thermal resistance of clothing,

activity level, state of mind and time spent in the given zone. A state of thermal comfort is often referred to when analyzing the thermal environment. Chapter 2.2 will provide a more thorough presentation introducing thermal comfort models.

The atmospheric environment is affected by contaminants of the air further affecting the air quality. Particularly in office buildings, determining factors are internal heat loads, particles, smell and solvents as well as dust loads. The experience of the atmospheric environment is also affected by the air temperature, relative humidity and length of stay. The CO_2 level indoors is normally used as the main indicator of air quality. Current standards recommend the CO_2 concentrations to not exceed 1000 ppm or 1800 mg/m³ in order to achieve satisfactory indoor air quality (NTNU SINTEF 2007, page 136). This requirement will be used when analyzing results from both the field work and simulations.

An extensive field study completed in USA, Canada and Finland analyzed among other the perception of air quality. Importantly, results did show that quality of indoor air has great influence on productivity (Huizenga et al. 2006). In the case of low air quality, registered complaints included that the air was stale, not clean or contained odors. This was rated as a major problem, and the identified sources were odors from food, furniture, carpets as well as other occupants (Huizenga et al. 2006). Results further showed that satisfaction of indoor air was increased if operable windows were available (Huizenga et al. 2006). Local air movement is important in terms of both increasing air quality as well as thermal comfort (Fountain and Arens 1993). These findings imply that participants of the planned case study might rate thermal sensation as lower if the quality of indoor air is low. Furthermore, as satisfaction of indoor air is suggested to be increased if operable windows are accessible, a difference on this might be seen between the two test cells due to variation in operating strategies.

2.2. AN INTRODUCTION TO THERMAL COMFORT

Relevant literature describe different models on thermal comfort. The classical model was developed by P. O. Fanger and has been included in the European Standard NS-EN ISO 7730. However, other researchers have argued that this model does not fully represent the dynamic environment in an actual building (Brager and Dear 1998). This has resulted in the development of other models, modifying this standard or presenting new thinking, such as the adaptive approach or alliesthesia. Both agreements and suggested limitations have followed by fellow researchers on this field of study. This can be seen from the presented literature that follows. Several models exists with one being more fitted to a specific environment than another.

For the practical work of this thesis the main emphasis will be on the adaptive thermal comfort approach. This is due to the fact that relevant literature for most parts have been developed in warmer climate zones. It is of interest to analyze the basis of this model for the cold climate of Trondheim.

Thermal comfort can be defined as *a state of mind in which a person expresses full satisfaction with their thermal surroundings* (NTNU SINTEF 2007, page 125). Even though required conditions are known, it might still be difficult to achieve a state of thermal comfort due to complexity (NTNU SINTEF 2007, page 125). Different factors that can affect thermal comfort include air temperature, air velocity, mean radiant temperature, humidity, activity level and clothing (Alfano et al. 2014). Thermal comfort can also be influenced

by age of the occupant, tiredness, hunger and state of mind (NTNU SINTEF 2007, page 110). The influencing factors can be divided into four different categories; physical, physiological, behavioral and psychological. Furthermore, thermal comfort is determined by the following physiological criteria listed below, as defined in Energy Management in Buildings (NTNU SINTEF 2007, page 125):

- Skin temperature, 32-34 °C
- Core body temperature, 37-38 °C
- Sweat excretion < 0.25

2.3. STANDARD MODEL ON THERMAL COMFORT

The classical model on thermal comfort was developed by P. O. Fanger and later included in the European Standard NS-EN ISO 7730 (Norsk Standard, NS-EN ISO 7730 2006). The standard model has been, and is currently used as a basis in building design processes. In the given standard thermal comfort is defined as *that condition of mind which expresses satisfaction with the thermal environment* (Norsk Standard, NS-EN ISO 7730 2006). The model involves predicting the PMV and the PPD indices. PPD is additionally determined as a function of PMV. Definitions follow.

The standard model has been developed based on data gathered by completing experiments in climate chambers. This is comparable to the test cells to be occupied during the field work for this thesis. However, the climate chambers utilized by Fanger entailed controlled and static conditions. The indoor temperature was assumed to preferably be constant regardless of for example occupants or seasonal variations. In regards to the operation strategies to be followed in the test cell experiment, the occupants are rather active participants in terms of their thermal environment. Although, the user feasibility to control and interact with the indoor environment variate between the two test cells.

In P. O. Fanger's PhD thesis some factors are discussed in terms of their influence on the application of the comfort equation. Among these are age, sex and body build. Based on experiments P. O. Fanger suggested that these factors have no influence or is of such small influence that it is of no engineering significance (P. O. Fanger 1970). The experiments showed no difference in the optimal comfort temperature among college students and a group of elderly. Although mentioned that a small difference was expected as the metabolic rate decreases slightly with age. Similarly, the comfort conditions did not change when analyzing results after conducting experiments including both genders.

2.3.1. FANGER'S PMV AND PPD MODEL

PMV is short for Predicted Mean Vote. The index predict the mean vote of a large group based on the body heat balance. Fanger's model determine PMV in dependence of a total of six parameters. These include four climatic parameters; the momentary air- and radiant temperature, air velocity and relative humidity (P. O. Fanger 1970; Havenith et al. 2002a). The two final parameters are related to the occupants of the environment namely metabolism and clothing insulation value (P. O. Fanger 1970; Havenith et al. 2002a). A neutral state is obtained when the internal heat production of the body equals the losses of heat from the body to the surrounding environment. If in a state of discomfort, the body

will attempt to restore thermal comfort in terms of modifying skin temperature and sweat secretion (Norsk Standard, NS-EN ISO 7730 2006). The Predicted Mean Vote is identified by a seven-point scale ranging from -3 to +3 as shown below (Norsk Standard, NS-EN ISO 7730 2006). The ideal value is zero and represents a neutral state. This method will be the basis for determining the neutral temperature in the test cell experiment, as occupants shall rate their thermal sensation by using the seven-point scale.

Seven-point thermal sensation scale:

+3	-	Hot
+2	-	Warm
+1	-	Slightly warm
0	-	Neutral
-1	-	Slightly cool
-2	-	Cool
-3	-	Cold

The PPD index is short for Predicted Percentage of Dissatisfied (NTNU SINTEF 2007, page 124). Given some conditions, this index will clarify what percentage of people feel dissatisfied with the surroundings. In a large group there will always be some that find the thermal environment not satisfactory. This is accounted for as when PMV is 0 the PPD is 5%.

As presented in the European Standard NS-EN ISO 7730, the PPD index is calculated as a factor of PMV with Equation 2.1 (Norsk Standard, NS-EN ISO 7730 2006). The relationship between PPD and PMV is also presented with the graph in Figure 2.1.

$$PPD = 100 - 95 * \exp(-0.03353 * PMV^4 - 0.2179 * PMV^2) \quad (2.1)$$

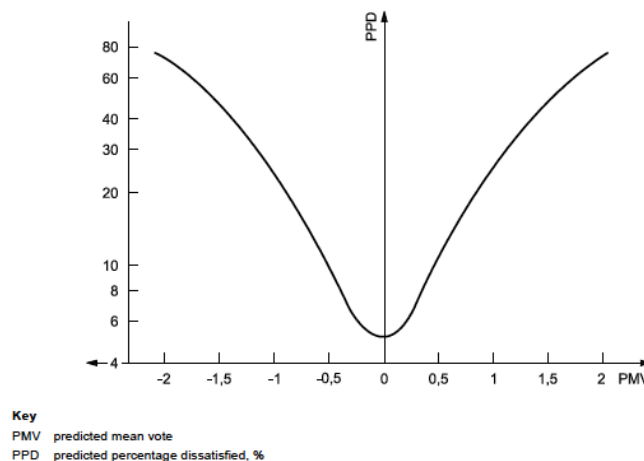

Figure 2.1.: PPD as a function of PMV, Ref.:(Norsk Standard, NS-EN ISO 7730 2006).

In order to differentiate acceptable levels of thermal comfort, standards have developed categories of the thermal environment. Table 2.1 show the three different categories as presented in NS-EN 15251 and their respective explanation. The standard NS-EN ISO 7730 based on Fanger's model of thermal comfort identifies the same categories by A, B, and C. Where A corresponds to | in NS-EN 15251, B to || and C to ||| respectively. NS-EN ISO 7730 include methods to predict thermal sensation and discomfort as well as requirement criteria. The standard also includes formulas for calculating the PMV and PPD indices, as that given in Equation 2.1. Similarly, NS-EN 15251 present requirements for parameters concerning the indoor climate in regards to the energy use of a building. One of the differences between the two standards is that NS-EN 15251 does not include criteria for local discomfort. Furthermore, NS-EN 15251 takes thermal adaptation into consideration.

Table 2.1.: Categories defining thermal comfort acceptability according to NS-EN 15251.

Category	Description
	High level of expectation. A recommended category for buildings occupied by fragile or sick persons with special requirements.
	Normal level of expectation. Intended used in new buildings or buildings to be renovated.
	Moderate level of expectation. An acceptable category for existing buildings.

Table 2.2 shows the value of the PMV and PPD indices for the different categories as defined in NS-EN ISO 7730. The European Standard states that the value for the PMV index should stay between -0.5 and +0.5 if aimed at the middle category for normal expectations (Norsk Standard, NS-EN ISO 7730 2006). In correlation, this yields a PPD value of less than 10% implying that 90% of occupants should be satisfied.

Table 2.2.: Design criteria for comfort indices by NS-EN ISO 7730.

Category	PPD in respective category [%]	PMV in respective category
A	< 6	$-0.2 < PMV < +0.2$
B	< 10	$-0.5 < PMV < +0.5$
C	< 15	$-0.7 < PMV < +0.7$

There are given requirements for acceptable deviations on indoor climate parameters. For shorter periods of time it is considered acceptable that limited discomfort occur. Examples include occupants experiencing draft due to pulse ventilation by opening of windows, or indoor temperatures deviating from a given optimum. NS-EN 15251 states that deviation should only occur 3% of the time if a room constitute 95% or more of the hours of occupancy (Norsk Standard, NS-EN 15251 2014). An overview of the given recommendation and what that represents in hours of a given period is shown in Table 2.3.

Table 2.3.: Allowed deviation on indoor parameters as recommended in NS-EN 15251.

Period	Daily [<i>min</i>]	Weekly [<i>h</i>]	Monthly [<i>h</i>]	Yearly [<i>h</i>]
Time of 3% allowed deviation	43	5	22	259

2.3.2. MAYER'S MODIFICATIONS TO FANGER'S MODEL

Mayer developed a modified thermal comfort model based on Fanger's PMV and PPD model. Mayer chose to focus also on preference and not only thermal sensation. However, the relationship between PMV and PPD was still to be determined. He found that a thermal sensation rated as -1 or slightly cool is perceived as uncomfortable (Hellwig et al. 2006). This subdivision of thermal votes can be seen in Figure 2.2 as well as in Chapter 2.3.1 with the definition of the seven-point thermal sensation scale. Furthermore, it was suggested that an environment can still be comfortable even though regarded as slightly warm (Hellwig et al. 2006). This implied that the minimum of percentage dissatisfied is 16% as opposed to Fanger's 5%. The minimum percentage of dissatisfied at 16% is reached at a PMV of +0.4. This again can be seen in Figure 2.2, where PPD as a function of PMV is shown for both Fanger and Mayer's models. Mayer's model on thermal comfort fits best with actual observed values for air-conditioned buildings (Hellwig et al. 2006).

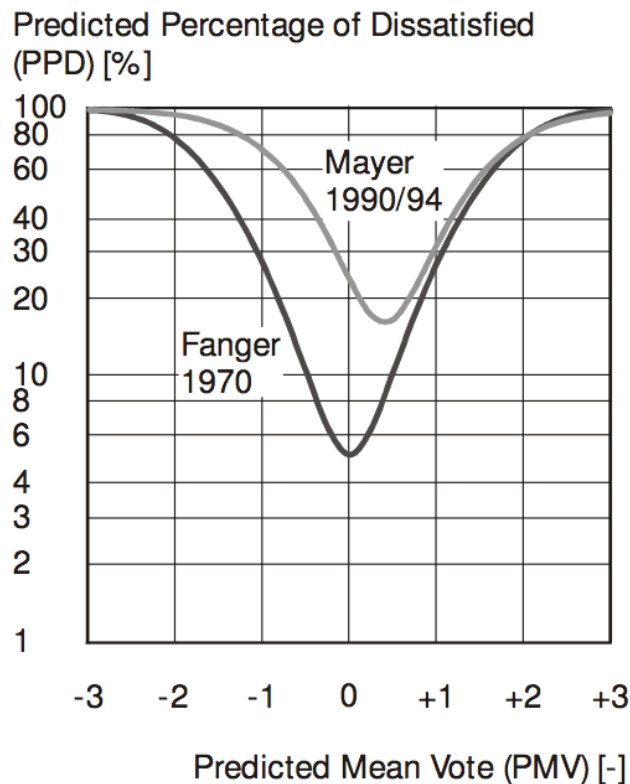

Figure 2.2.: PPD as a function of PMV for both Fanger and Mayer's models, Ref.: (Hellwig et al. 2006).

2.3.3. A CRITICAL OVERVIEW OF THE STANDARD MODEL

The standard model on thermal comfort is developed in a chamber further implying that the model is based on static conditions. Several researchers on this field have argued that this could potentially not be an adequate approximation of reality. In a literature review by Brager and de Dear, this is addressed. They question whether occupants of different building types and locations would define comfort as the same (Brager and Dear 1998). As discussed in Humphrey and Nicol's article from 1998, some factors that are likely to have influence are culture, climate, personality and affluence (Humphreys and Nicol 1998). It has also been suggested that interior and color affects thermal sensation (Oseland 1995). This implies that an occupant of a laboratory chamber might feel colder due to the feel of the room.

Occupants in the standard model are considered passive, and although clothing insulation and activity level might differ, these values need to be anticipated beforehand as they are inputs that are needed in the model. In correlation to this, Brager and de Dear argues that clothing insulation might differ greatly from values gathered during laboratory tests on manikins (Brager and Dear 1998). Additionally, two garments might have different *clo* values although the same type due to fabric variations. In the case of a work situation, the office chair is also found to add approximately 0.15*clo* to the initial clothing value (Brager and Dear 1998). Similarly, Havenith et al. specifies that insulation value of clothing is also affected by body temperature and air movement. As activity level or air movement becomes higher, insulation value and vapour resistance are reduced (Havenith et al. 2002b). This implies that more heat is lost through the clothing. However, clothing vapour resistance is neglected in the standard model. Results in the given article shows that an initial error in metabolic rate of 15%, can result in an error of 0.3 or more of the PMV value (Havenith et al. 2002b). Oseland suggests that tabulated [*met*] values should be specified after environments and not only on activity level. A given reason is that activity level seems to increase with for example stress in work situations (Oseland 1995).

This static model has also been criticized because it does not take outdoor conditions into consideration (Sourbron and Helsen 2011). As discussed in Van Hoofs article from 2012, people in warmer climates tend to prefer higher indoor temperatures compared to occupants in colder areas (Halawa and Van Hoof 2012). A severe limitation is the model one-size-fits-all approach, according to Brager and de Dear (Brager and Dear 2000).

Similarly, Falk Schaudienst and Frank U. Vogdt have discussed whether or not Fanger's standard model is more suitable for men (Schaudienst and Vogdt 2017). A tendency is that women prefer a higher temperature level than men. Following, the resting metabolic rate is higher for men than women (Schaudienst and Vogdt 2017). It also decreases with age. As stated in the given article, this naturally implies that the PPD value increases with age and is higher amongst women. Results presented showed that predicted values gives a better fit for men (Schaudienst and Vogdt 2017). However, the standard person is based on a healthy and normal weighted man between the age of 25 and 30. When in reality a room is occupied by a variety of people with different age, activity level and gender. The same tendency has been shown in an article from 2015 analyzing thermal comfort in an Italian hospital (Del Ferraro et al. 2015). The main focus of the research included differences in gender and age. A mentioned limitation was the low number of subjects participating in this specific hospital study, and Del Ferraro et al. suggested that more comprehensive research is needed.

In an article by Arens et al. from 2010 the variation in preferences among occupants were discussed (Arens et al. 2010). Different levels of clothing or activity level both affected the optimal indoor temperature (Arens et al. 2010). Furthermore, it was suggested that the narrow ranges of temperatures are unnecessary and require a greater amount of energy. Studies presented in the given article by Arens et al. showed that the different categories of acceptability, as presented in Table 2.1 and Table 2.2, did not show differences in comfort. According to Arens et al. there is no observed advantage of classifying the tight PMV ranges. A suggested solution is that buildings preferably can be classified in terms of accessible user control or required energy used to ensure thermal comfort (Arens et al. 2010). This is relevant to the field work of this thesis where user controllability should be analyzed. Likewise, a field study in Quebec revealed low accuracy between predicted PPD values and observed thermal acceptability (Donnini et al. 1997). This result applied for both the ASHRAE standard 55 and the NS-EN ISO 7730 with its presented PPD indices and corresponding requirements.

Contrary, an advantage of the PMV model is its flexibility including all parameters that seem to influence thermal sensation, as suggested in the work of Fanger and Toftum (Fanger and Toftum 2002). Accordingly, it has been the international standard since the 1980s (Fanger and Toftum 2002).

2.4. ADAPTIVE THERMAL COMFORT

In their article from 2001 Brager and de Dear presented a new adaptive comfort standard for ASHRAE 55. Furthermore, they argued that the decisions made during the design process should not be uniform, neglecting building variations. This is due to the fact that parameters of great influence differ. The following conclusion was that the one-size-fits-all approach is not adequate, and what they describe as; *a misguided fad of the last century* (Brager and De Dear 2001). Halawa and van Hoof is suggested to have a similar point of view. In their article from 2012 on the adaptive approach to thermal comfort, the preferred temperature was suggested to be a function of the outdoor temperature. This indicates that with a higher outdoor temperature, a higher indoor temperature is accepted and vice versa (Halawa and Van Hoof 2012). This contradicts the standard model of thermal comfort. In accordance, Nicol proclaims that existing models solely based on the heat balance following; *fails to explain the range of temperatures that people found comfortable in buildings with the variable indoor temperatures characteristic of naturally ventilated buildings* (Nicol 2011). In the same publication, an editorial to Building Research & Information, he suggests that an adaptive approach that is based on field studies; *presents a solution to the problem* (Nicol 2011).

The adaptive approach is based on results from extensive empirical field studies. A large database has been used when developing the adaptive thermal comfort model. Now the occupants are no longer assumed to be passive, but rather active participants who are comfort-seeking (Halawa and Van Hoof 2012). Humphreys and Nicol gives the following statement regarding the adaptive principle; *if a change occurs such as to produce discomfort, people react in ways that tend to restore their comfort* (Humphreys and Nicol 1998). Occupants are assumed to take charge and restore a state of thermal comfort. Adaptation mechanisms can be divided into three main categories. These are behavioural, physiological and psychological (Sourbron and Helsen 2011). In an article by Baizhan Li et al. from 2012, these adaptive mechanisms have been presented in graphical form and is shown in

Figure 2.3. As pointed out in Brager and de Dear’s article on thermal adaptation, there is a person-environment relationship present. Occupants behave as active participants adjusting to the system via multiple feedback loops (Brager and Dear 1998), as can be seen in Figure 2.3.

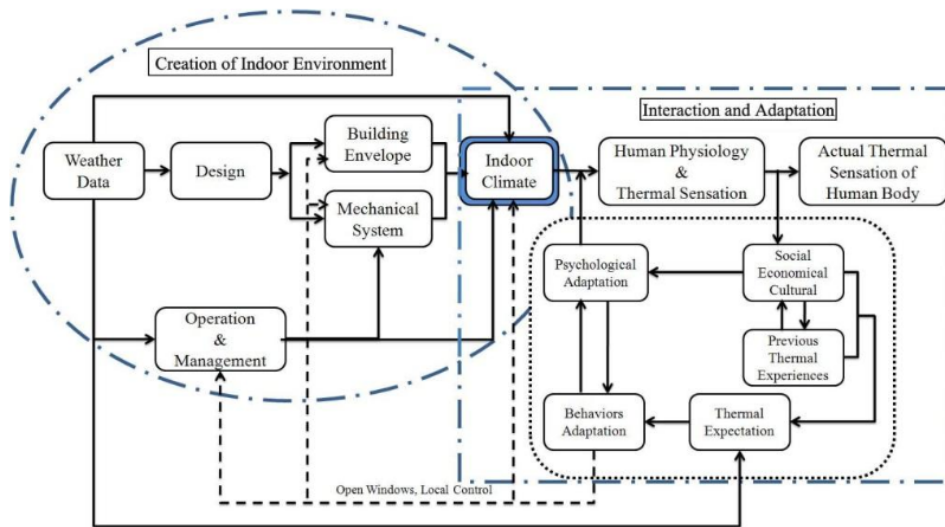

Figure 2.3.: A graphical overview of adaptive comfort mechanisms, Ref.:(Li et al. 2012).

Suggested in the featured article by Brager and de Dear is the fact that behavioral adjustment provides the greatest opportunity for the occupants to adjust to the environment in order to maintain comfort (Brager and Dear 1998). Similarly, Chatonnet and Cabanac expressed that; *behavioral thermoregulation is well-developed in man and becomes preponderant and tends to supplant other forms of thermoregulation* (Chatonnet and Cabanac 1965).

2.4.1. ADAPTIVE CONTROL ALGORITHM

The adaptive thermal comfort model take the outdoor conditions into consideration, as the indoor comfort temperature is assumed to be a function of the outdoor temperature (Halawa and Van Hoof 2012). Furthermore, a greater range of temperatures are suggested acceptable simultaneously resulting in greater energy savings. The practice of containing a constant and narrow range of temperatures, as proposed in the standard model, requires larger amounts of energy (Arens et al. 2010). This further necessities that occupants actually prefer this controlled operation to justify the increase in energy use (Arens et al. 2010). Contrary, the model on adaptive thermal comfort is developed on the basis of field studies showing results where people actually prefer a wider range of temperatures. Van Hoof et al. stated that introducing adaptive models could lead to an annual energy saving of 10% (Van Hoof and Hensen 2007). This number was found based on data gathered from naturally ventilated buildings located in moderate maritime climates.

However, the adaptive thermal comfort model has been criticized for being complex. In order to make the model more simple to apply in building designs, an adaptive control algorithm was developed, ACA (McCartney and Nicol 2002). The approach is developed

based on a regression model. A general equation is given below in Equation 2.2. The aim is to obtain the desired comfort temperature, and the building being free-running is a given prerequisite.

$$T_{com,f} = A * T_{a,out} + B \quad (2.2)$$

List of symbols:

- $T_{com,f}$ is the comfort temperature in [$^{\circ}C$]
- $T_{a,out}$ is the monthly mean outdoor air temperature in [$^{\circ}C$]
- A and B are constants

By doing extensive field studies in Europe the regression model presented in Equation 2.2 has been specified for different areas by defining actual values for the given constants. Table 2.4 presents the ACA equation for individual areas most relevant for the climate researched in this thesis, namely Trondheim. Here, the comfort temperature is given as a function of the running mean outdoor temperature, T_{RM} (McCartney and Nicol 2002).

Table 2.4.: Adaptive control algorithms for Europe and individual countries of relevance.

Area	$T_{RM} \leq 10^{\circ}C$	$T_{RM} > 10^{\circ}C$
Europe	$22.88^{\circ}C$	$0.302T_{RM} + 19.39$
Sweden	$0.051T_{RM} + 22.83$	$0.051T_{RM} + 22.83$
UK	$0.104T_{RM} + 22.58$	$0.168T_{RM} + 21.63$

In an article by McCartney and Nicol from 2002, this ACA model was both presented and tested. Two buildings were chosen for testing the performance of the algorithm, one in Sweden and one in the UK. Results showed an energy saving potential of 30% for the cooling load if the ACA model was applied rather than a fixed temperature setpoint (McCartney and Nicol 2002). The reason is that the adaptive control algorithm entail a higher control temperature. This is an important finding as the global energy use is a known issue. However, as pointed out in the given article, there will be some situations where the ACA model serves no benefits in terms of thermal comfort or energy savings. Further research is needed according to McCartney and Nicol.

2.4.2. ADAPTIVE APPROACH AS INCLUDED IN THE ASHRAE STANDARD 55

Richard de Dear and Gail S. Brager included an adaptive comfort model in the ASHRAE standard 55 that applies for naturally ventilated buildings. Richard de Dear had expressed skepticism regarding the classical model based on laboratory research. He stated that; *there are persistent doubts about the experimental realism of the chamber methodology.*

The aim of the American ASHRAE standard 55 is to *specify the combinations of indoor space environment and personal factors that will produce thermal environmental conditions acceptable to 80% or more of the occupants within a space* (Brager and De Dear 2001).

The results substantiating the presented model were gathered from an extensive database. ASHRAE began to collect data from office buildings by completing field studies on thermal comfort as early as in the mid-1980's, covering four climate zones (Brager and De Dear 2001). An extensive database has been developed including both questionnaires, estimates of clothing and metabolic values as well as meteorological observations to mention some.

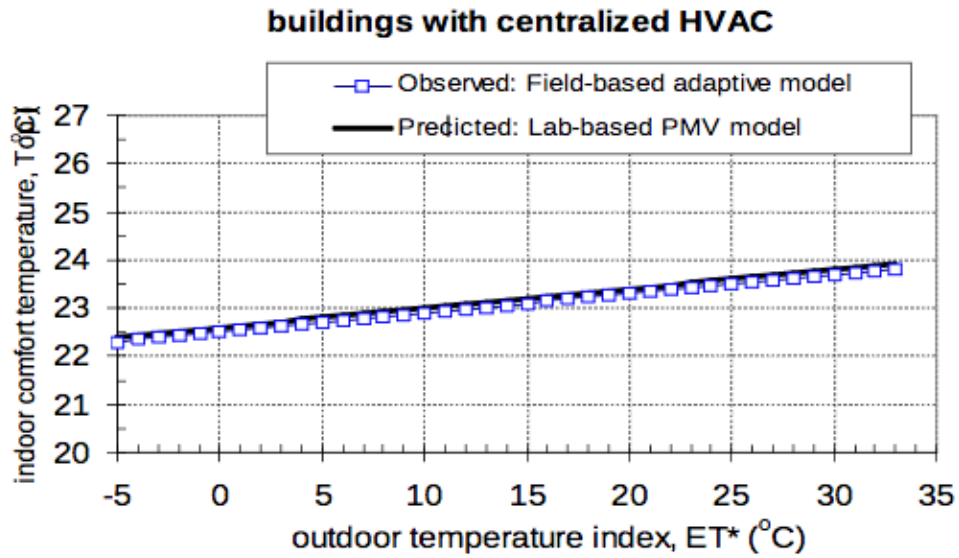

Figure 2.4.: Observed and predicted comfort temperatures for HVAC buildings, Ref.:(Brager and De Dear 2001).

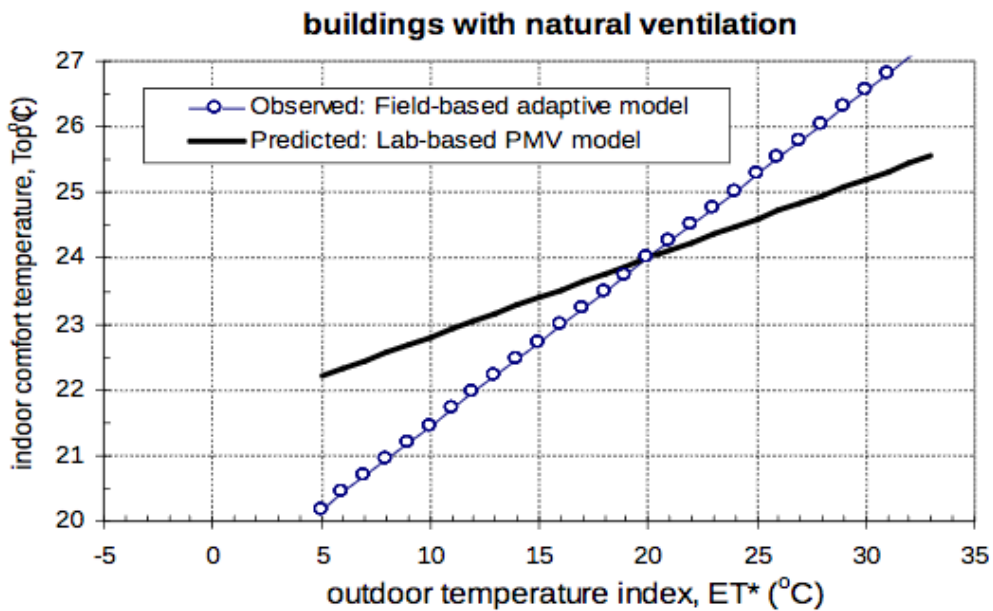

Figure 2.5.: Observed and predicted comfort temperatures for natural ventilation, Ref.:(Brager and De Dear 2001).

Figure 2.4 and Figure 2.5 are presented with the aim of showing the results that led ASHRAE to include an adaptive approach in their standard. As seen from Figure 2.4 the predicted and observed comfort temperatures are concurrent for HVAC buildings. The standard PMV model achieves for such a case a well fitted prediction of optimal temperatures. Occupants of HVAC buildings become well adopted to a narrow range of temperatures. Another study by Richard de Dear and Gail S. Brager presented in their article from 2000, *A standard for natural ventilation*, showed results where occupants of centralized HVAC buildings were in fact twice as sensitive to changes in temperature (Brager and Dear 2000). Occupants of HVAC buildings seem to have higher expectations for thermal consistency and become critical when the indoor temperature deviates from the optimal value (Norsk Standard, NS-EN 15251 2014). This is contradictory to the theory of the adaptive approach where occupants are suggested to prefer a wider temperature range. As initiated in Chapter 2.2, several models exist with one being more fitted to a specific environment than another.

For the naturally ventilated buildings, the predicted and observed comfort temperatures does not show the same correspondence (Brager and De Dear 2001). This can be seen in Figure 2.5. The adaptive thermal comfort model predicts this trend better for naturally ventilated buildings as outdoor temperature is taken into consideration. Another field study showing similar results is presented in the work of Wagner et al. from 2007 (Wagner et al. 2007). Results were gathered from 50 office buildings with natural ventilation located in Karlsruhe in Germany. The research showed that the perception of thermal comfort did not correspond to the classical model on thermal comfort where PMV was used as the evaluating index (Wagner et al. 2007). However, a great correlation was seen when applying the adaptive thermal comfort model. With these results on naturally ventilated buildings, the dependence between outdoor temperature and perceived thermal comfort could be confirmed as stated in the given report (Wagner et al. 2007). According to the Norwegian standard NS-EN 15251, people in naturally ventilated buildings seem to prefer this wider temperature range. It is in fact similar to what one would actually experience in a building with natural ventilation. Occupants of these buildings prefer temperatures more closely tracking the outdoor climate patterns (Brager and Dear 2000). A possible reason for this is their ability to exert control of their own environment (Brager and Dear 2000). Although how natural ventilation is applied can vary between buildings and accordingly the user feasibility to control indoor conditions. However, in general it is greater than the closed off environment experienced in a mechanically ventilated building.

The PMV model gives a well and presumably better fitted prediction for buildings that are mechanically ventilated with HVAC systems (Hellwig et al. 2006), but fails to anticipate the conditions of naturally ventilated buildings. The warmer temperatures do not seem to be as big of a problem as the PMV model predicts. One proposed explanation is given in the work of Fanger and Toftum from 2002. The metabolic rate perhaps was set too high when developing the PMV model (Fanger and Toftum 2002). It was not accounted for that when people feel too warm they unconsciously reduce their activity level in order to restore a state of thermal comfort. This is where the adaptive approach gives a better fit.

2.4.3. ADAPTIVE APPROACH AS INCLUDED IN THE NS-EN 15251 STANDARD

The adaptive approach given in the ASHRAE standard 55, led the European standard NS-EN 15251 to introduce a similar model. This is presented in Figure 2.6. The graph is developed based on the equations presented for the adaptive model in the given standard (Norsk Standard, NS-EN 15251 2014, page 28). By comparing the graphs in Figure 2.6 and Figure 2.5 it is noticeable that a wider temperature range is accepted with the adaptive approach than the predicted PMV model. By allowing a greater variation of temperature there is no need to activate the heating and cooling system by the smallest temperature change. This indicates that there lies a possibility to reduce energy. Additionally, adaptation makes sense in terms of peoples way to act in a rational way (Nicol 2011). The end goal is comfort and people use the controls available in order to achieve this. Examples may include opening and closing of windows, change radiator thermostat and external or internal shading. Humans are above all comfort seeking (Nicol 2011).

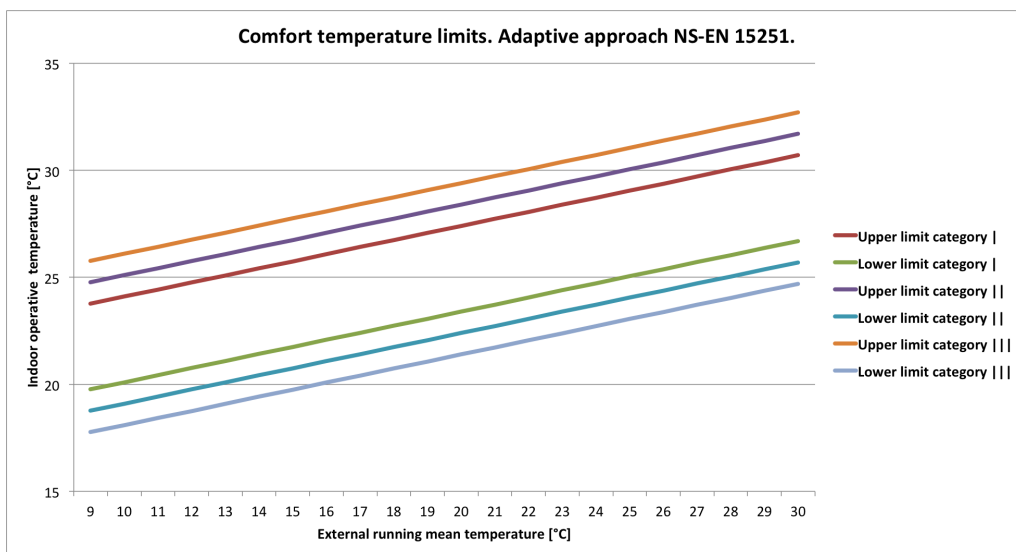

Figure 2.6.: Acceptable operative temperatures for the NS-EN 15251 adaptive approach, Ref.: (Norsk Standard, NS-EN 15251 2014).

2.4.4. A CUSTOMIZED CHINESE STANDARD

When designing a building, either a new construction or refurbishment project, one important element of the energy efficient building design process is the IEQ. During this process standards are used in order to set relevant parameters and choose design conditions. The same standards are often used as a starting point regardless of building location and climate. The international comfort standards typically used, as for example ASHRAE and ISO, are for most parts based on data gathered from North American and northern European subjects. This led Baizhan Li et al. to question whether or not these standards apply to environments where design conditions might vary from these subjects the model is based on (Li et al. 2012). Consequently they presented a more fitted standard for free-running buildings in China in their article from 2012 (Li et al. 2012).

China covers a total of five climate zones regarding building design, varying from very cold to both warm summers and winters. In order to develop a new model both field studies and laboratory studies were completed. Over 20 000 subjects attended the field studies covering all five climate zones, in addition to 500 involved in the laboratory studies. Results showed that Chinese people have a tendency to be more tolerant to thermal stress (Li et al. 2012). Additionally, the standard PMV model overestimated the thermal sensation for summer conditions and underestimated for winter. If this standard model were still to be used, this could potentially result in greater energy use than necessary. A final result from the study were the fact that Chinese people are active in terms of behavioural adaptation (Li et al. 2012). These findings resulted in a model named the Adaptive Predicted Mean Vote model, hereafter referred to as aPMV. This model takes into consideration factors such as culture, climate and social, psychological and behavioral adaptations (Li et al. 2012). The model is presented in the case of an equation and includes an adaptive coefficient, λ , as shown in Equation 2.3 (Li et al. 2012).

$$aPMV = \frac{PMV}{1 + \lambda PMV} \quad (2.3)$$

List of symbols:

- PMV is the predicted mean vote
- λ is the adaptive coefficient.
 $\lambda > 0 \implies$ warm conditions; $\lambda < 0 \implies$ cold conditions.

Note that when the adaptive coefficient equals zero, the aPMV is identical to the value of PMV. This implies laboratory conditions and no adaptive actions. The values of the coefficient suitable for different conditions have been obtained by doing extensive field studies. An example relevant to the climate of Trondheim to be researched in this thesis follows. The λ value for office buildings located in very cold and cold climates is set to be 0.24 (Li et al. 2012). That is when PMV is greater than or equal to zero. This empirical value is suggested suitable for a given climatic region in China, determined based on both onsite parameter monitoring and surveys on thermal sensation. As pointed out by Baizhan Li et al., occupant behaviour is a dynamic and active process affected by various factors. Examples include climate, culture and economics. This indicates that the exact adaptive coefficients should be regained if applied to other areas although similar climate. This is in order to increase reliability of the calculation method. The model also provides a graphic method based on the running mean outdoor temperature and the criteria of the operative temperature. The general aim, given in the featured article, is to have a standard that is easy and provides a guidance to be used in the design process (Li et al. 2012).

2.4.5. A CRITICAL OVERVIEW OF THE ADAPTIVE APPROACH

As stated, the adaptive approach is applied preferably to naturally ventilated buildings. The wider range of temperatures is in fact preferred. However, take the specific case of an office building. If a desk situated far from the window is occupied, then opening of a single window far away might not give satisfactory conditions. Simultaneously, the occupant with a desk next to the opened window might express complaints on draft. In this case the space is ventilated based on adaptive mechanisms. However, the fixed desk consequently result in lower user feasibility of controlling the indoor environment. Other

examples include climatic conditions. In warm weather it might not help to open the windows as the outdoor temperature is higher than inside, or in a cold climate the low outdoor temperature might cause discomfort in terms of vertical temperature gradients. Lastly, in some areas opening of windows might result in indoor pollution regarding both noise and lowering indoor air quality. These are situations where various factors as a result limit the user controllability. This can be seen as a limitation as in situ conditions contradicts assumptions of the adaptive model.

Similarly, the preferred thermostat setpoint for a radiator might vary greatly among occupants of the same room (Arens et al. 2010). As an example, temperature preferences might vary due to different levels of clothing, or activity. Occupants of non-residential buildings dress in the morning before going to work, leaving the possible variation of clothing insulation levels behind with their wardrobe. The weather forecast could be a determining factor (Morgan and Dear 2003), or even the weather of the foregoing days. It is likely that a person dresses based on the weather of yesterday, assuming that it has not changed. Additionally, women have a tendency of wearing more clothing than men in the winter, but less at summertime (Morgan and Dear 2003). Furthermore, at some work places there might even be a dress code that must be followed. Take an office for example, where employees in some cases are expected to wear a suit. This give the occupants smaller opportunity to react themselves in restoring comfort. It leaves the occupants with limited behavioural adaptation as only an outer layer can be taken on or off.

One drawback of the adaptive approach presented by Fanger and Toftum is the model's lacking of important parameters included in the PMV model such as clothing, activity, air temperature, air velocity, humidity and mean radiant temperature. Halawa and van Hoof also gave a critical overview of the adaptive approach to thermal comfort in their article from 2012. The need for a separate comfort chart for naturally ventilated buildings were being questioned (Halawa and Van Hoof 2012). A proposed solution was that the heat balance model including modifications for elevated high air speeds might be sufficient (Halawa and Van Hoof 2012). The adaptive model ignores this with its current regression model (Halawa and Van Hoof 2012). Having standards based on field studies is of great importance, and it is proposed in the given article that the theory developed on the adaptive model could be used to improve the PMV approach (Halawa and Van Hoof 2012). Also suggested was the fact that the adaptive approach has pushed the range of thermal comfort to the critical boundary. There is a fine line between where a given thermal sensation is regarded as acceptable or cross over to being unacceptable (Halawa and Van Hoof 2012). The adaptive models states that occupants' expectations are met. However, nothing is clarified as to why some conditions are acceptable and others are not (Dear 2011).

Another mean is that energy cost and sustainability might affect peoples actions and result in a longer lasting state of thermal discomfort. Lastly, even though a wider range of temperatures is accepted this might unconsciously affect productivity. Richard de Dear states the following; *if the very best that can be achieved in an isothermal, cool, dry and still indoor climate is neutral or acceptable for little more than 80% of a building's occupants at any one time, then the standards that have been set to date leave much to be desired* (Dear 2011). Further he suggests a paradigm shift introducing a new way of thinking about thermal comfort, namely alliesthesia (Dear 2011).

With the research knowledge presented it has been shown that thermal comfort is dependent on several factors not taken into consideration in the standard model. The current point of view is that a variety of approaches defining thermal comfort and optimal tem-

peratures exists, with one being more fitted to a specific environment than another. As suggested by Hellwig et al., the closest agreement between predicted and perceived comfort conditions is shown if applying Mayer's modifications to Fanger's PMV standard. That is if the building is mechanically ventilated. This varies from naturally ventilated buildings where ASHRAE standard 55 turns out to be a more appropriate model (Hellwig et al. 2006). The dynamic relationship between occupants and the environment has been shown to be of great importance, and can be revealed through extensive field studies. This indicates that a model as the customized Chinese standard might be an advantageous approach. If the achieved result is that predicted and observed comfort conditions are concurrent, the energy use can be minimized. Contrary, a consequence is that complexity increases.

2.5. ALLIESTHESIA

In his lecture on thermal counterpoint in urban climate, given at the University of Hong Kong, professor Richard de Dear presented several different scenarios often regarded as comfortable by people, however not in accordance with the standard model on thermal comfort. The first example include people lying on a beach. They will feel the heated sand below them and have direct sunlight on the front of the body. Based on the standard model on thermal comfort these situations should lead to discomfort. Large vertical temperature gradients or asymmetry in radiation is rated as undesirable. Another example could be saunas where people tend to shift quickly between a hot and cold environment when taking an ice bath to cool down before reentering the sauna. This is not a steady state situation like the classical model of thermal comfort is based on. Furthermore, thermal neutrality given as zero on the seven-point scale shows that the person is neither warm nor cold. Richard de Dear specifies an important fact relevant here. This thermal neutrality does not say anything about like, dislike or satisfaction (Dear 2015).

Alliesthesia is a phenomenon that is used to separate thermal pleasure from thermal neutrality and acceptability (Dear 2011). The term was developed by Michel Cabanac and has origin in the two Greek words *alloios* which means change, and *aisthisis* meaning sensation (Luc Pénicaud 2016). Following, the phenomenon can be defined as *the perception of an external stimulus as pleasant or unpleasant, depending upon internal stimuli* (Farlex and Partners 2017). In terms of thermal comfort, Parkinson and de Dear has given a more specific definition in their article from 2015 presenting the physiology of alliesthesia; *at its simplest, thermal alliesthesia states that the hedonic qualities of the thermal environment are determined as much by the general thermal state of the subject as by the environment itself* (Parkinson and Dear 2015). An example from everyday life could be that one type of food might taste great when very hungry, but then again not at all appealing when full. The exact same stimulus might be perceived as positive at one time and negative at another; positive and negative alliesthesia respectively. Similarly, increased air movement would cause discomfort if the body temperature is lower than at the neutral state, but refreshing if the occupant feels too warm. One man's breeze is another man's draft.

2.5.1. TEMPORAL ALLIESTHESIA

The fundamental principle of alliesthesia can be explained in terms of a load-error. A stimulus that eliminates the occurred load-error and restores thermal comfort will be perceived as pleasant and is characterized as positive alliesthesia and vice versa (Parkinson and Dear 2015). How great this effect is seems to be dependent on the initial state of the occupant and the magnitude of the load-error with respect to time. In other words, whether or not a stimulus is perceived as pleasant or not depends on its potential to restore the neutral state of the body with minimal regulatory strain (Parkinson et al. 2012). The duration of the state of pleasure is also determined by the magnitude of the load-error and efficiency of the stimuli to restore comfort (Parkinson et al. 2016). Alliesthesia, in terms of thermal comfort, seems to be stronger when the occupant has a body temperature that is far from its preferred temperature (Dear 2015). The impact of the general thermal state of the occupant has not been taken into consideration in previous standards on thermal comfort.

The principle described above is driven by load-errors of central origin, or more specifically driven by the contrast between core and skin temperature trends. This is referred to as the whole body model of alliesthesia, or temporal alliesthesia. The development of a model on alliesthesia has been stated as necessary as new technologies have been introduced. The environment in a building is no longer steady state (Dear 2011). According to Parkinson et al., dynamic environments can deliver a higher level of thermal comfort than steady state (Parkinson et al. 2012). There is a need for models that predict the real life scenarios better and provide a fuller understanding.

George D. Mower completed in 1976 a field study that clearly showed the effect of thermal alliesthesia. Four male subjects participated in the study, and the aim was to test various stimuli ranging from cold to warm in correlation to the initial condition of body temperature (Mower 1976). The applied method was water immersion, and the results are shown in Figure 2.7. The three initial states of internal body temperature were hypothermia, normal and hyperthermia, i.e. reduced temperature as the body dissipates more heat than it absorbs, normal state and elevated temperature as the body produces or absorbs more heat than it dissipates. The subjects were asked to rate the stimuli in terms of both intensity of warmth or coolness and hedonic quality of pleasantness or unpleasantness (Mower 1976). By analyzing the graphs in Figure 2.7 it is clear that the perception of the stimuli is depending on the initial state of the body temperature. If in a state of hypothermia, low initial body temperature, a low stimulus temperature is rated as very unpleasant. Opposite, when hyperthermia is the initial state the same stimulus is regarded as very pleasant. It is also shown that the degree of pleasant- or unpleasantness is greater if the stimulus temperature is far from the neutral temperature. This corresponds to the effect of the load-error as discussed in the previous paragraph.

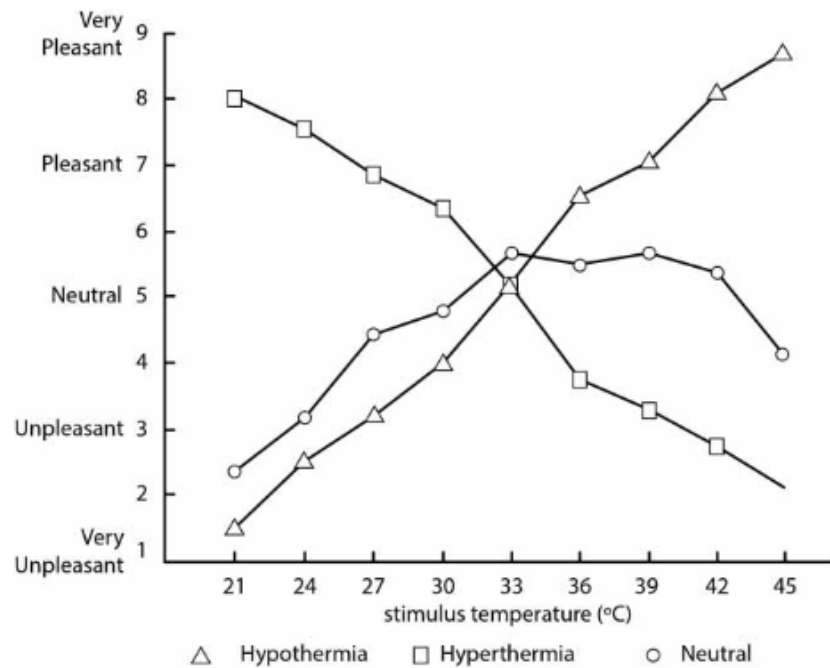

Figure 2.7.: Results from Mower’s field study showing an example of thermal alliesthesia, Ref.: (Parkinson and Dear 2015).

A study showing similar results has been presented in an article by Parkinson et al. from 2012 where pleasure and alliesthesia was discussed. Subjects were postponed to temperatures ranging upwards and downwards from a neutral state. This was done after exercise. Results showed that the exact same stimulus can feel pleasant at one time and unpleasant at another, all depending on the initial thermal state of the body (Parkinson et al. 2012). Alliesthesia was suggested to help explain the fact that occupants accept a more dynamic indoor environment (Parkinson et al. 2012). Findings revealed that pleasure depended on the initial state, occurred directly after change and for a limited time period (Parkinson et al. 2012). This indicates that user control is of great significance in order to reduce thermal boredom and initiate thermal pleasure regularly. As the initial state of the body is an important factor, ignored by an automatic operating system, user control provide the occupant with the possibility to more actively optimize conditions directly based on individual state and preference.

2.5.2. SPATIAL ALLIESTHESIA

As described when introducing temporal alliesthesia, thermal pleasure and displeasure is assumed to be present as core temperature deviates from the neutral state. This is referred to as the whole body model of alliesthesia (Parkinson and Dear 2015). Real life experiences show that the experience of alliesthesia can be more local and topically administered. An example here can be when cold hands is being wrapped around a warm mug for comfort. Such local experiences of pleasant- or unpleasantness has been called spatial alliesthesia (Parkinson and Dear 2015). Summarized, temporal alliesthesia is referring to the traditional whole body alliesthesia. This is present under temporally varying,

sequential, transient exposures (Parkinson et al. 2016). Unlike spatial alliesthesia which is referring to so called in situ thermal pleasure (Parkinson et al. 2016). This can arise due to thermal stimuli applied to a more local region on the body surface. In the featured article by Parkinson and de Dear the spatial model on alliesthesia is stated to be more conventional (Parkinson and Dear 2015). It gives a more complementing representation of actual scenarios from real life.

An interesting fact in this context is the amount of cold versus warm spots on the human skin. On the nose for example, the amount of cold spots are $8\text{spots}/\text{cm}^2$ in human skin, whilst there is only one warm spot (Dear 2015). Skin cold receptors are more sensitive to transients than warm receptors (Dear 2015). A given reason for this is that the cold receptors are located more superficially in skin tissue and closer to the skin surface (Parkinson and Dear 2015).

The models on alliesthesia encourages professionals to exploit the variations in climate. It has been suggested that such an interpretation can in fact minimize thermal boredom in built environments (Dear 2011). Actually, variations in body temperature could be initiated in order to stimulate dynamic thermal alliesthesia (Parkinson et al. 2012). An example relative to this statement is that one could get all the nutrition needed during the day from a single pill. However, this would initiate boredom. There is lot of social and culture around food and dining. The same can apply to thermal environments.

2.5.3. A CRITICAL OVERVIEW OF ALLIESTHESIA

An evident criticisms or skepticism regarding a thermal comfort model on alliesthesia is that more research is needed as the methodology is still in an early state of evolution (Parkinson et al. 2016). Still, little is known about why some environments are perceived as comfortable and some are not (Dear 2011). Also initiated in Chapter 2.4.5 when discussing adaptive thermal comfort, more complex models also imply that the actual application is more of a challenge. Similarly, as discussed in Parkinson and de Dear's article, if a building is mechanically ventilated with the aim of ensuring a constant temperature then the standard model including the determination of the PMV and PPD indices is more appropriate and gives a better presumption (Parkinson and Dear 2015). As stated in the article by Candido et al. from 2006, if alliesthesia should be applied to steady state contexts then availability of personal control is given as a precondition.

Parkinson et al. describes what is called as; *one of the most prominent criticisms of alliesthesia* (Parkinson et al. 2012). That is the following, displeasure must occur in order to experience pleasure (Parkinson et al. 2012). In the mentioned article by Candido et al. from 2006 this exact tendency is discussed. Many researchers and professionals on this field of study have dismissed the concept of alliesthesia for that exact reason (Parkinson et al. 2016). A counterargument could be that pleasure is greater if the experienced displeasure was strong. Additionally, a study presented in the given article showed that thermal discomfort did not need to be the previous state in order to experience a state of pleasure (Parkinson et al. 2016). A noted limitation is the small sample of subjects used to derive this result. Again, further research is necessary.

2.6. ACCEPTABILITY MODELS OF THERMAL COMFORT

As discussed earlier in this literature review, field studies have shown differences between actual and presumed comfort preferences. This chapter presents some acceptability models developed based on extensive field studies as well as being compared to current standards. This is of relevance as occupants' optimal temperatures and thermal sensation should be studied during the experimental work to be done in the ZEB Test Cell Laboratory. A thorough description of this field work can be found in Chapter 3.

A field study of relevance is presented in the work of Hellwig et al. from 2006. After completing over 4400 interviews, the validity of the standard thermal comfort model by Fanger as well as Mayer's modified model was analyzed (Hellwig et al. 2006). This was done by comparing acceptability models developed based on gathered data from participants to the curves representing the two standard models. The data were divided into different categories based on type of ventilation. These include air-conditioning, further subdivided into partial and full air-conditioning, and natural ventilation as shown in Figure 2.8. The naturally ventilated buildings have also been analyzed in terms of season as seen in Figure 2.9. Additionally, the correspondence between acceptability models for perceived user control and Fanger and Mayer's models were analyzed as presented in Figure 2.10. This is of great relevance to this thesis objective. Hence, this will be further addressed presenting relevant literature in Chapter 2.7 on occupant behaviour and user control.

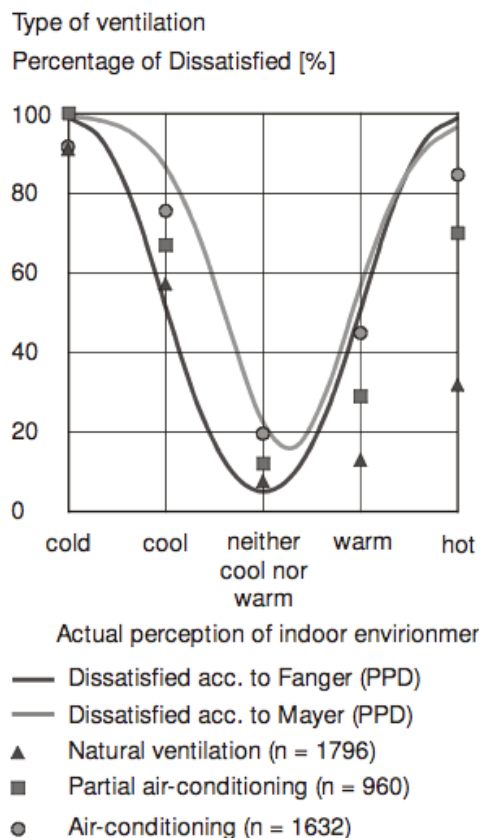

Figure 2.8.: Acceptability models based on type of ventilation, Ref.:(Hellwig et al. 2006).

Figure 2.8 show percentage of dissatisfied in correlation to actual perception of the indoor environment. PPD according to Mayer show the most comparability for fully-air conditioned buildings. This trend was also indicated in Chapter 2.3.2 when presenting the model by Mayer. For the lower half of the scale, ranging from neutrality to cold, Fanger succeed to predict actual perception for natural ventilation. However, the model fails to anticipate dissatisfaction as the actual perception of the indoor environment is rated as warm or hot.

As initiated in Chapter 2.4.2, the warmer temperatures does not seem to be as big of a problem as predicted by the standard model. Occupants of naturally ventilated buildings become well adapted to a dynamic environment more closely tracking the outdoor conditions. They are provided with more flexibility as a wider range of user control is available. This trend can be affirmed by analyzing the curves in Figure 2.8. With a thermal sensation of warm the PPD is 13%, increasing to 32% as the actual perception reaches hot (Hellwig et al. 2006). For comparison these values equal 38% and 82% respectively for the mechanically ventilated buildings (Hellwig et al. 2006). This represents a substantial increase.

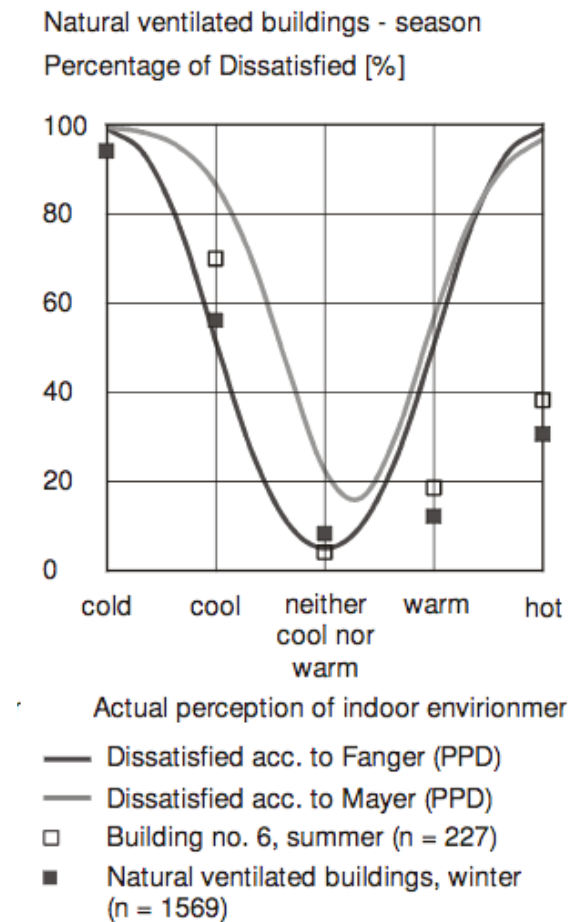

Figure 2.9.: Acceptability models for naturally ventilated buildings based on season, Ref.:(Hellwig et al. 2006).

The results show little difference between seasons, as seen in Figure 2.9. A limitation of the study is the low number of participants engaged in the summer analysis. Further research is necessary in order to draw conclusions on the impact of seasonal affects (Hellwig et al. 2006). However, it is within reason to conclude that both PPD models fail to predict actual perception of naturally ventilated buildings.

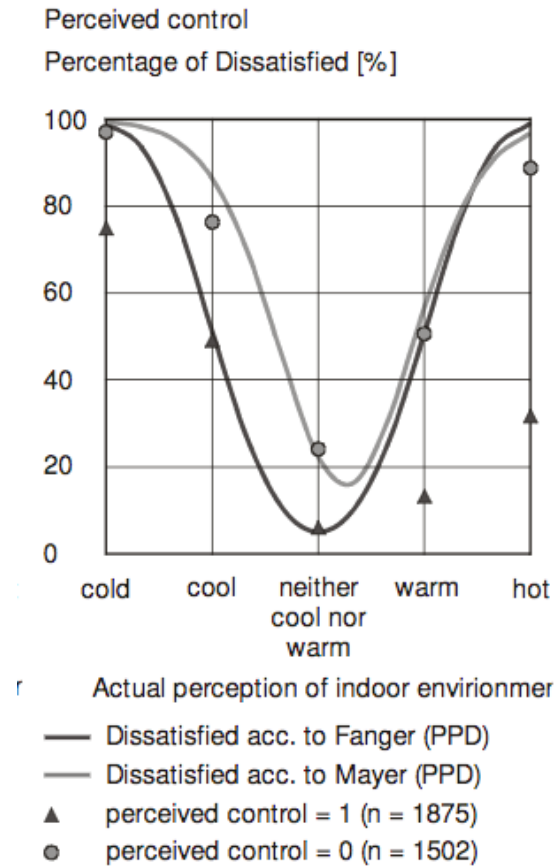

Figure 2.10.: Acceptability models based on perceived control, Ref.:(Hellwig et al. 2006).

The findings on user control are presented in Figure 2.10. Perceived control of zero basically represents a fully air-conditioned building. Opposite, perceived control of one is comparable to natural ventilation. At a value of zero Mayer's model corresponds to the curve of actual perception. This matches the results found when discussing Figure 2.8. As perceived control reaches one, none of the models predicts the distribution of dissatisfied. This percentage is not as high when user control is available. As stated in the given article; *Fanger's PMV-PPD relation seem to be inappropriate.*

2.7. OCCUPANT BEHAVIOUR AND USER CONTROLLABILITY

Usual building design methods today include automatic systems based on optimized solutions. This implies that the user feasibility to control the indoor environment as a result becomes lower. Such an environment contradicts to some extent the adaptive theory where occupants are regarded as active in accordance to the adaptive principle. That is; *if a change occurs such as to produce discomfort, people react in ways that tend to restore their comfort*, as stated by Humphreys and Nicol (Humphreys and Nicol 1998). Additionally, occupants are often more forgiving of the conditions if user controls are available, and also report a higher level of comfort (Clements-Croome 2006). In naturally ventilated buildings controls available include operable windows or vents, doors, blinds and curtains, central heating, hot air blowers and electric or gas heaters (Raja et al. 2001). Following, the standard NS-EN 15251 discusses that different field studies have shown results differing from normalities when the building is naturally ventilated with operable windows. An explanation given in the standard is the fact that people in naturally ventilated buildings will have a different thermal experience, and again, occupants will have more control of the indoor environment due to availability of operation (Norsk Standard, NS-EN 15251 2014).

As initiated, user control is of relevance to the adaptive approach. If a person starts to feel uncomfortable or expect to feel uncomfortable, the occupant unconsciously take the signal in active measures and tries to restore comfort (Brager and Dear 1998). Further suggested in an article by Brager and de Dear is that adaptive control should ideally be evaluated in terms of available control vs. exercised control vs. perceived control, namely adaptive opportunity vs. behavioral adjustment vs. expectations respectively (Brager and Dear 1998). A relevant field study presented by Wagner et al. was developed based on 16 different office buildings located in Germany (Wagner et al. 2007). The aim of the study was to analyze adaptive thermal comfort in order to reveal the possibility of energy savings. This study revealed higher satisfaction among occupants when opportunity of control was given. Another example regarding possible energy savings follows. A 1.5°C difference in natural temperature has been shown for buildings providing low and high user control (andersen2009survey).

Brager completed an extensive study, collecting over two thousand survey responses. When results are gathered from a large database it is reasonable to presume the study as reliable. The aim was to investigate how operable windows would affect occupant comfort and the indoor environment. The study from 2004 looked at a naturally ventilated office building in both heating and cooling season. Brager found that preferred temperatures were close to the actual experienced temperatures when occupants had been given the opportunity of control (Brager et al. 2004). The report stress that buildings should be designed in order to facilitate custom control, making the occupants active participants. Perhaps spaces with natural ventilation, providing occupant control, would not be experienced as an imposed indoor environment, compared to when the building design is separated from the outdoors allowing no individual control. This is comparable to an example from everyday life. If you are the one renovating your apartment, you probably have a lot of excitement and will not be bothered with the chaos, clutter and noise. You have a positive approach to the situation, and will get something positive out of it. In comparison, you most likely wouldn't be as thrilled if it was your neighbour doing the renovation. Then the same noise, is now considered annoying. Perhaps it did not sit well with your own plans as you were caught off guard. If you are the one in control you will probably allow more. Should the conditions get uncomfortable are you able to make modifications.

In an article by Raja et al. it was suggested that the use of controls in naturally ventilated buildings are driven by the outdoor and indoor temperature. A field study was completed in order to show the relationship between the use of controls and temperature. This was done by the use of regression analysis. Additionally, frequency of use of different control mechanisms were researched. First stated was that air movement is one of the most efficient means when wanting to improve thermal comfort. Results showed that windows were operated to a great extent among occupants. As indoor temperatures exceeded 20°C a great share of the subjects chose to open the windows. Furthermore, when temperatures reached 25°C most windows were open whilst only a few if temperatures became as low as 15°C (Raja et al. 2001). As a total windows were open in 62% of the responses. For comparison, blinds or curtains were drawn in 24% (Raja et al. 2001). A similar study has been presented in the work of Nicol, where 50% of occupants in European offices opened windows as temperatures reached 22°C (Nicol 2001). Curtains or blinds were utilized in about 40% of the cases (Nicol 2001). In Europe, the use of curtains or blinds seem to not be dependent on temperature, as stated in the given article. This control mechanism is more often used in warmer weather, but is essentially due to glare from windows (Nicol 2001).

Following, Brager and de Dear have in their article from 1998 presented field studies as evidence for adaptation. Mechanisms such as operable windows, blinds or heaters were rated as efficient. Similar results are given in the work of Andersen et al. where a danish survey response showed that windows were an effective measure and dependent on outdoor temperature. The use of windows can improve both air quality and thermal comfort in the case of lowering indoor temperature (Nicol 2001). Windows tended to stay open from the time when occupants felt too warm until feeling cold (Andersen et al. 2009). This implies that thermal sensation ranges between too warm and cold as windows are held open until a state of thermal neutrality or discomfort is reached. Another interesting finding presented in the work of Brager and de Dear were the use of personal behavioral mechanisms. These include taking a break and making a hot or cold drink. These were the controls containing the highest number of citations (Brager and Dear 1998). This is even though only implying a slight and time limited improvement in thermal comfort. A more effective personal measure is reducing or increasing level of clothing. However, only 12% chose to do so (Brager and Dear 1998).

A final example to be highlighted regarding satisfaction and user control, include the field study introduced in Chapter 2.1 when defining the atmospheric environment. Over 34 thousand survey responses were gathered from three different countries further increasing reliability of the study. An interesting results were that percentage of satisfied increased from 56% to 76% as a thermostat were available for the heating supply (Huizenga et al. 2006). In accordance to the field studies presented in previous paragraphs, also here windows resulted in significant increase in satisfaction. More specifically, a 10% increase (Huizenga et al. 2006). Interestingly, occupants provided with portable fans or heaters showed lower satisfaction with the thermal environment, a reduction of 9% and 15% respectively (Huizenga et al. 2006). Nevertheless, participants of the study believed that portable fans or heaters have a large potential to increase comfort and also reduce energy use (Huizenga et al. 2006). That is if individuals have other preferences than the majority. Accordingly, portable fans or heaters can help to obtain preferred thermal conditions more locally. Huizenga et al. stress that user control ought to be provided to more occupants. A result is higher level of satisfaction.

2.7.1. EFFECTS ON ENERGY USE

User behaviour naturally varies from occupant to occupant. This further implies that the energy consumption due to user controls might differ accordingly. As more controls are available it becomes more difficult to predict the energy performance of a given building as user behaviour differ greatly. One study revealed a variation in energy consumption between identical houses to be a value of 600% (Andersen et al. 2009). The same trend has been shown in the work of Garland et al. where a handful of residential buildings were analyzed in terms of monitored energy consumption. Variation between the occupants' behaviour regarding opening of doors and windows accounted for a difference in energy consumption of 17% (Garland et al. 1993). Changing of heating setpoints resulted in an even larger variation, namely 27%. This study was completed in Washington. An example from a climate more similar to Norway and relevant to the discussed field of study, is given in the work of Hunt and Gidman. This research found an unusual low average household temperature at 15.8°C (Hunt and Gidman 1982). The study was developed in the UK, and one possible explanation given was their motivation to use adaptive mechanisms in order to stay comfortable and simultaneously reduce their heating bills. This again shows the influence of user behaviour. It does also show that user behaviour is diverse and can be due to different reasons. Such include energy bills as mentioned, environmental concerns, social factors or a pressure from society to conserve energy. The relationship between the occupants and the building environment is dynamic and should not be fully ignored.

As stated in the work of Oseland, offering occupants controls and providing a possibility for them to adapt to their environment appears to be the most efficient way of building design in terms of both energy and comfort (Oseland 1995). Similarly, Raja et al. concludes that user control is key and plays a significant role in terms of bettering indoor thermal conditions. Such an approach will increase building performance (Raja et al. 2001).

2.8. RELEVANCE OF RESEARCH

This thesis on comfort preferences and operating strategies is of relevance to the energy saving challenges the world is facing today. The energy consumption in the building sector alone is of grand scale. Relevant literature has demonstrated a need for measures with immediate affects, both small and large. If a comfort standard was to be applied in the design phase that does not correspond to observed thermal preferences this could result in a greater energy use than necessary.

The adaptive model is developed based on the perception that occupants are active participants when it comes to the indoor environment. This is more accurate to how a scenario would occur in an actual building. Likewise, it is similar to the operating strategy to be followed in the test cell experiment. A test cell with manual operating strategies will be occupied simultaneously as a test cell with automatic control. Then comfort preferences can easily be compared. Furthermore, the temperatures accepted by occupants are assumed to differ from case to case. Thermal comfort is influenced by a range of parameters and possibly the outdoor climate. The test cell experiment will analyze just this with the cold climate in Trondheim. This will contribute to further develop such research in colder climates. As shown through the literature review, a large amount of the studies have been developed in climate zones not directly transferable to countries with colder weather.

Occupant perception of thermal comfort can vary greatly and has been shown to influence expected results. This further emphasize the importance of field studies. Actual feedback from occupants is an essential factor influencing the outcome of the research. This is taken into consideration during the field work as a questionnaire will be one of the measuring methods.

Through the literature review the standard predicted values of mean vote and percentage of dissatisfied has been shown to not always correspond to observed comfort preferences. This affects the optimal temperatures further affecting energy use. The deviation between standard comfort indices and actual perception of thermal comfort should be studied in this thesis. Registered user behaviour and conditions are to be implemented in IDA ICE and simulated comfort indices can be compared to occupant feedback gathered from questionnaires.

Minimization of energy use and maximization of thermal comfort can to some extent be conflicting factors. Finding an optimal crossing point is key in order to minimize energy consumption. Relevant literature has shown that user behaviour can affect design values to a great extent. Accordingly, user strategies on operable windows will be further analyzed. The aim is to see how much energy use for heating variate as the occupants way of utilizing a given control variate.

3. FIELD WORK AT ZEB TEST CELL LABORATORY

This chapter contains a presentation of the laboratory facilities and the experimental work to be done in the ZEB Test Cell Laboratory in Trondheim. The purpose of this field work is to analyze user controllability in correlation to thermal comfort. The research aim is to answer the key questions rendered in the list below.

- *Do the participants of the case study rate thermal sensation differently when the zone is automatically optimized providing no user controllability, or when occupants have the possibility to affect the control strategies?*
- *To what extent is the occupants' acceptable indoor temperature affected by the user feasibility to control the indoor environment?*

3.1. FME ZEN

This master's thesis is associated with the newly established Research Centre on Zero Emission Neighbourhoods in Smart Cities, FME ZEN. The research centre was established in 2017 at NTNU with the aim of developing sustainable neighbourhoods with zero greenhouse gas emissions in order to enable the transition to a low carbon society (*FME ZEN*). NTNU and SINTEF works as the two main research partners alongside 10 public partners and 21 industry partners (*FME ZEN*). The activities are divided into six individual work packages (NTNU 2016) although multidisciplinary collaboration is important in order to achieve the end goal. The final and sixth work package concerns pilot projects and living labs (NTNU 2016) and include the ZEB Test Cell Laboratory to be occupied during the field work for this master's thesis. The specific goal for this relevant work package is among other to utilize living labs in order to verify, document and optimize real life performance of solutions (*FME ZEN*).

3.2. SKINTECH

SkinTech is an ongoing research project in the lead of SINTEF Building and Infrastructure (*SkinTech*). It aims to develop new knowledge and solutions for walls and windows (*SkinTech*). The intention is to integrate smart technology in exterior surfaces (*Smarte fasader*). The research work also focuses on energy savings in the operation phase simultaneously as thermal- and visual comfort should be obtained and improved. As a part of the SkinTech project different experiments will be completed in the ZEB Test Cell Laboratory. The experiment concerns measurements on thermal comfort. The collaboration for this thesis will be regarding data collection and analysis.

3.3. ZEB TEST CELL LABORATORY

The ZEB Test Cell Laboratory is an experimental facility located in connection to the campus of NTNU in Trondheim, with coordinates at 63°41' north and 10°41' east and an altitude of 40 m.a.s.l. (Cattarin et al. 2017). It was built by The Research Centre on Zero Emission Buildings at SINTEF and NTNU. It is a multipurpose experimental facility where the aim is to be able to develop and optimize several solutions simultaneously. Examples include building materials and envelopes, energy installations and control systems (*Test Cell Laboratory*).

The facilities allow experiments to be done simultaneously in two small rooms as it is possible to divide the test cell into two separate chambers. This can be seen in Figure 3.2 (*Test Cell Laboratory*). The mentioned possibility is useful as different technologies and solutions can be compared under identical and realistic operational conditions. These separated chambers will be utilized in the following experimental work. One cell will be automatically operated, whilst the other will provide users with the possibility to control their indoor environment to a greater extent.

The total area of the laboratory is approximately 135m² (Goia et al. 2017). This includes the measuring area with the two test cells, a control room and placing of the service and HVAC equipment. A general overview of the layout is shown in Figure 3.2. The external wall of both chambers are faced south. The remaining five surfaces is surrounded by an environmentally controlled volume (Goia et al. 2017). This implies that each cell have identical conditions although fully independent. Figure 3.1 shows the external walls of the two test cells.



Figure 3.1.: South facade of the ZEB Test Cell Laboratory. Photo: Stina Skeie.

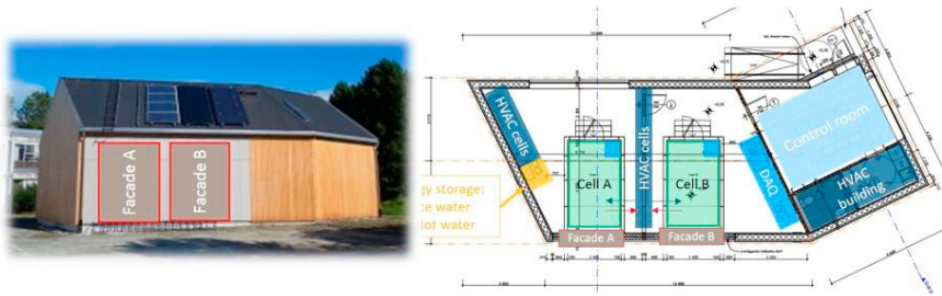

Figure 3.2.: Left: External surface from south. Right: Floor plan of the building, Ref.: (Goia et al. 2017).

3.4. METHOD OF EXPERIMENTAL WORK

The experimental work in the lead of SINTEF and the SkinTech project consists of four parts, where only the last phase is done in collaboration with this thesis. This face include measurements on thermal comfort and energy performance. The data will be analyzed with regards to thermal comfort and the indoor environment, specifically air quality. The three first phases consists of preparations in terms of testing setup and equipment.

3.4.1. TIME PERIOD

The experiment is to be completed during the spring of 2018. More specific time data follows.

Year	2018
Week	18
Date	30.04.18-04.05.18
Duration	A minimum of 5 hours each day depending on work hours of the participants

3.4.2. PROCEDURE

The two cells will be representing office spaces for this experimental work. Figure 3.3 shows the entrance of the test cell and the exterior surface. Furthermore, Figure 3.4 shows the setup as an office with the desk and chair. Each cell will be occupied by one person during working hours. For how long they choose to work in the test cell is optional, but a requirement of five hours has been set in order to replicate an office work situation and have enough data for presenting results.



Figure 3.3.: Exterior of the cell.
Photo: Stina Skeie.



Figure 3.4.: Inside the test cell.
Photo: Stina Skeie.

Test cell A will provide an environment that the user have some degree of control over. Windows, thermostat, external shading and general light will be manually operated. Test cell B however, will be automatically controlled and computer operated. A general overview comparing the different control strategies for the two test cells can be found in Table 3.1. A more detailed description of the control strategies are given in Chapter 4.2 in correlation to the simulation model to be developed in IDA ICE.

Table 3.1.: Control strategies defining test cell operation.

Test Cell	Cell A	Cell B
Top window	User operated	Computer operated
Bottom window	User operated	Always closed
Desk light	User operated	User operated
Room light	User operated	Computer operated
Radiator thermostat	User operated	Fixed
External shading screen	User operated	Computer operated

3.4.3. MEASUREMENT AND TEST CELL SETUP

The test cells will be utilized as office spaces. As seen from the simple sketch in Figure 3.5, a desk and chair is placed at the long side of the room. A large window dominates the external wall facing south. Figure 3.6 show the window type installed viewed from the outside. It is delivered by the company NorDan. Only the two parts of the window containing dotted lines on the sketch is possible to open, namely window *aa* and *da*. These two windows are referred to as the top- and bottom window respectively. The remaining two parts will always be held closed. Both cells will only have a system for heating with a waterbased radiator. A balanced ventilation system will supply fresh air at fixed temperatures. There is no cooling system provided other than opening of windows.

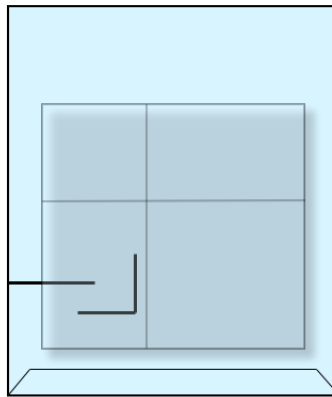

Figure 3.5.: Simple sketch of the office space. Photo: Stina Skeie.

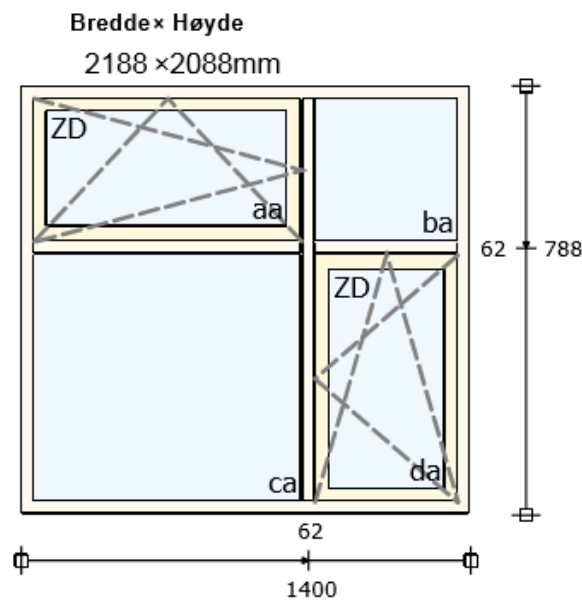

Figure 3.6.: Detailed sketch of the test cell window by NorDan. Viewed from the exterior.

The analysis is articulated in several steps including both detailed measurements by sensors and questionnaires ensuring valuable feedback from occupants. The questionnaire is presented in more detail in Chapter 3.4.5. An installed web camera will sensor and track the occupant motion. This will ensure a more detailed tracking of user behaviour, show activity level and overview the users operation strategies. The picture taken by the web camera is censored by low image resolution. This is due to privacy for the occupant. An example of a picture taken is given in Figure 3.7. The tripartite collecting of information will enable a more thorough understanding in order to analyze discrepancy between occupant answers, sensor measurements and recorded actions.

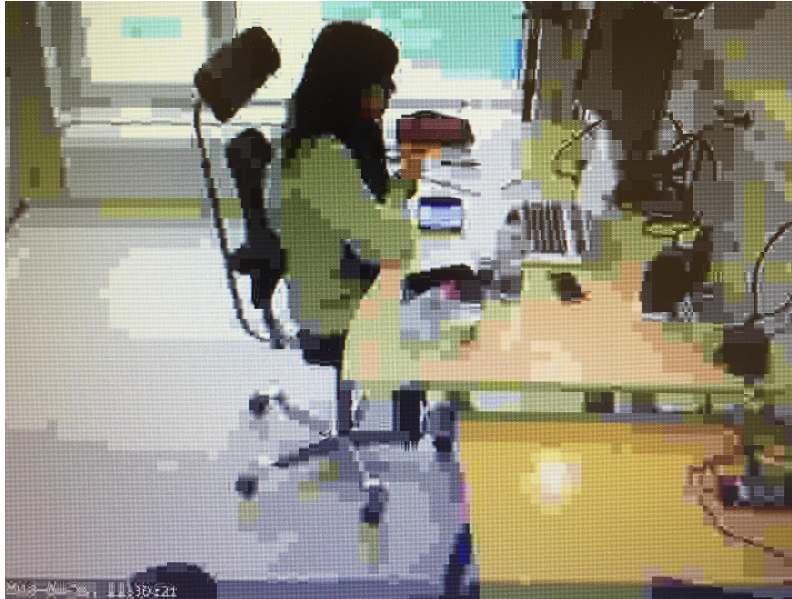

Figure 3.7.: An example of a picture taken by the web camera showing occupancy.
Photo: Stina Skeie.

An extensive amount of sensors are installed in order to detailed overview the conditions in the cell. Measured outputs of relevance are summarized in Table 3.2. In addition to the variables mentioned in Table 3.2, the system will also measure control activation of screen and windows, power outputs and weather data.

Table 3.2.: Measured outputs to be gathered in the two test cells.

Measured value	Measuring device	Timestep
Air velocity	3 sensors per cell	Every 60 seconds
Surface temperature	16 sensors per cell	Every 60 seconds
Air temperature	3 sensors per cell	Every 60 seconds
Radiant temperature	1 sensor per cell	Every 60 seconds
Relative humidity	1 sensor per cell	Every 60 seconds
CO_2 level	1 sensor per cell	Every 60 seconds
Lux level	2 sensors per cell	Every 60 seconds
Occupancy	1 web camera per cell	Every 60 seconds

Surface temperature will be measured by thermocouple sensors placed on the test cell internal surfaces. The sensor is small in order to limit the radiant error and also provide a low time constant. The radiant temperature will be measured by a thermocouple black ball at a smaller size. This implies that the effect of the air temperature and air velocity is greater, simultaneously reducing accuracy of the radiant temperature. This has to be noted when analyzing the results. The air temperature is measured by Pt100 sensors. Three sensors of this kind are installed on a tripod at three different heights. The instrument used to register air velocity is an anemometer, typically used to measure smaller velocities which normally occur in rooms. As for the air temperature, also three sensors are installed to measure the air velocity. The setup for measuring radiant temperature, air temperature and air velocity can be seen in Figure 3.8. This setup is included to be able to calculate the operative temperature. A plan for how this will be done is presented in Chapter 5.1. A closeup of the anemometer and the Pt100 sensors is given in Figure 3.9. The tripod is placed approximately $1m$ from the external surface and the window. As can be seen from Figure 3.9, the air temperature sensor is covered with a piece of cardboard in order to limit radiation that could affect the accuracy of the results.

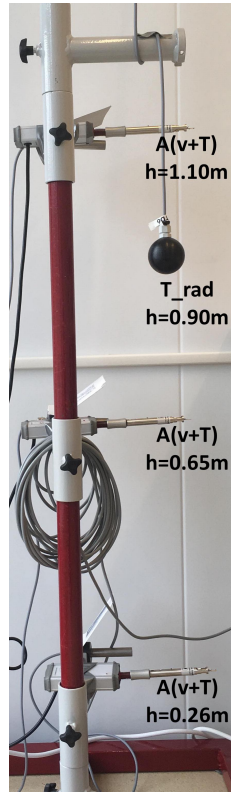

Figure 3.8.: Tripod setup with sensors measuring air velocity, air- and radiant temperature.
Photo: Stina Skeie.

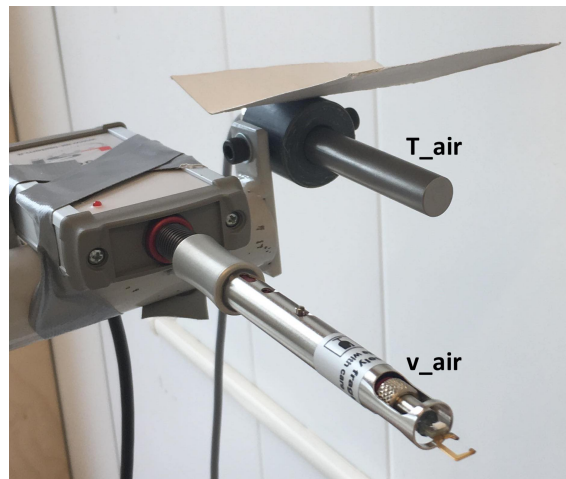

Figure 3.9.: Closeup of the anemometer and Pt100. Photo: Stina Skeie.

Relative humidity is measured at one location. This is assumed sufficient as vapour pressure is normally equal throughout the room. At the same location CO_2 level is measured. This setup can be seen in Figure 3.10. This picture also shows one of the thermocouples measuring surface temperature.

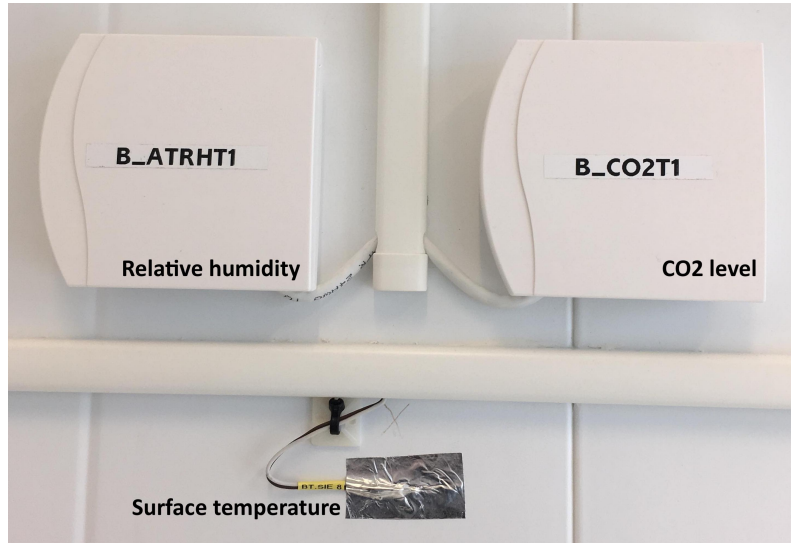

Figure 3.10.: Setup of sensors measuring CO_2 , relative humidity and surface temperature. Photo: Stina Skeie.

A more thorough list of the sensor types and manufacturer is included in Appendix A. The sensors and measurements will be registered in LabVIEW. This is a program used to collect data that further helps to visualize the setup, as the program is developed based on a visual programming language. As an example, the interface showing test cell A is presented in Figure 3.11. Note that this include more sensors than needed to be able to present results relevant for this thesis.

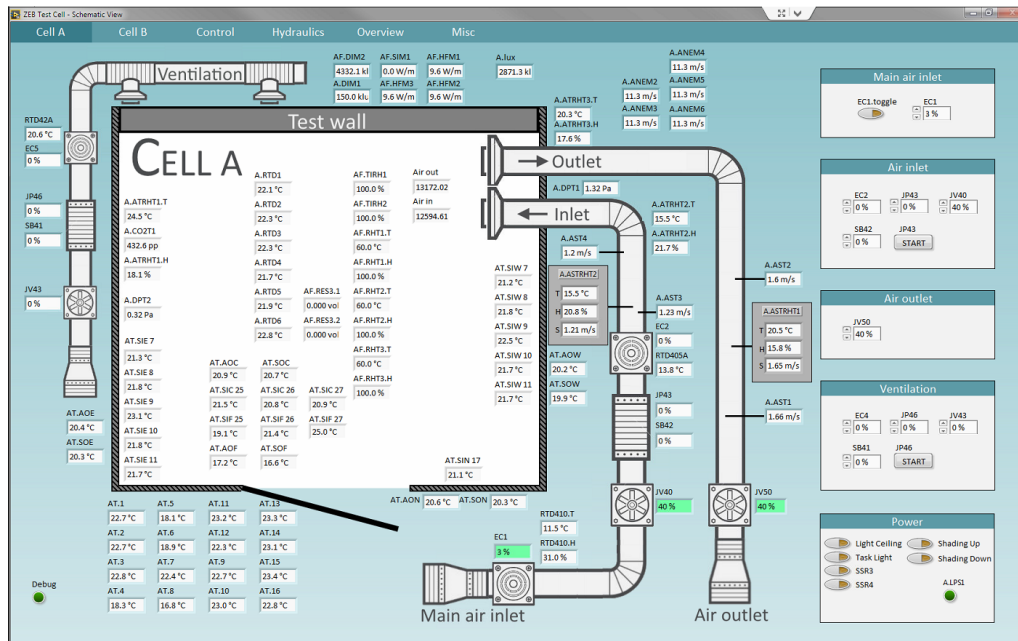

Figure 3.11.: LabVIEW interface showing sensors for test cell A.

3.4.4. CALIBRATION OF ANEMOMETERS

At the ZEB Test Cell Laboratory a variety of equipment that can be used for different measurements are installed permanently to be used in experiments. Hence, they have been calibrated. This applies for all the sensors needed for this thesis except the anemometers. This equipment had to be brought in separately in order to be able to calculate the operative temperature, which is important for thermal comfort analysis. The anemometer type has been shown in Figure 3.9 and measures air velocity. In order to minimize error and disturbances affecting the results, the anemometers needed to be calibrated. That included all six sensors, three in each cell. The aim has been to develop a function for each anemometer that could be applied to already measured values in order to get more reliable results with low uncertainties. The calibration was completed at the laboratory and in each cell where the sensors were installed ensuring that conditions were similar to those during the experiment. This way the noise from wires connecting the anemometers was also taken into consideration.

A list of the equipment utilized is given below. The portable equipment used for the calibration is shown in Figure 3.12. It is a TSI 1125 calibrator with a 6.4mm circular nozzle. The anemometer was pushed through an opening and in to the centre of the cylinder. PTFE tape was used to limit any leakage around the inserted anemometer. A compressor was separately connected to the calibrator at the compressed air inlet as shown on Figure 3.12. Furthermore, the setpoints for air velocity were correlated to pressure in Pascal. A manometer was used in order to overview the corresponding pressure setpoints. This equipment is shown in Figure 3.13.

Equipment used for the calibration process:

- TSI calibrator model 1125. Reg. Nr. vvs-464
- PPC 500 Pressure Calibrator
- Anemometers. Sensore microclima, lsi lastem
- Compressor
- PTFE tape

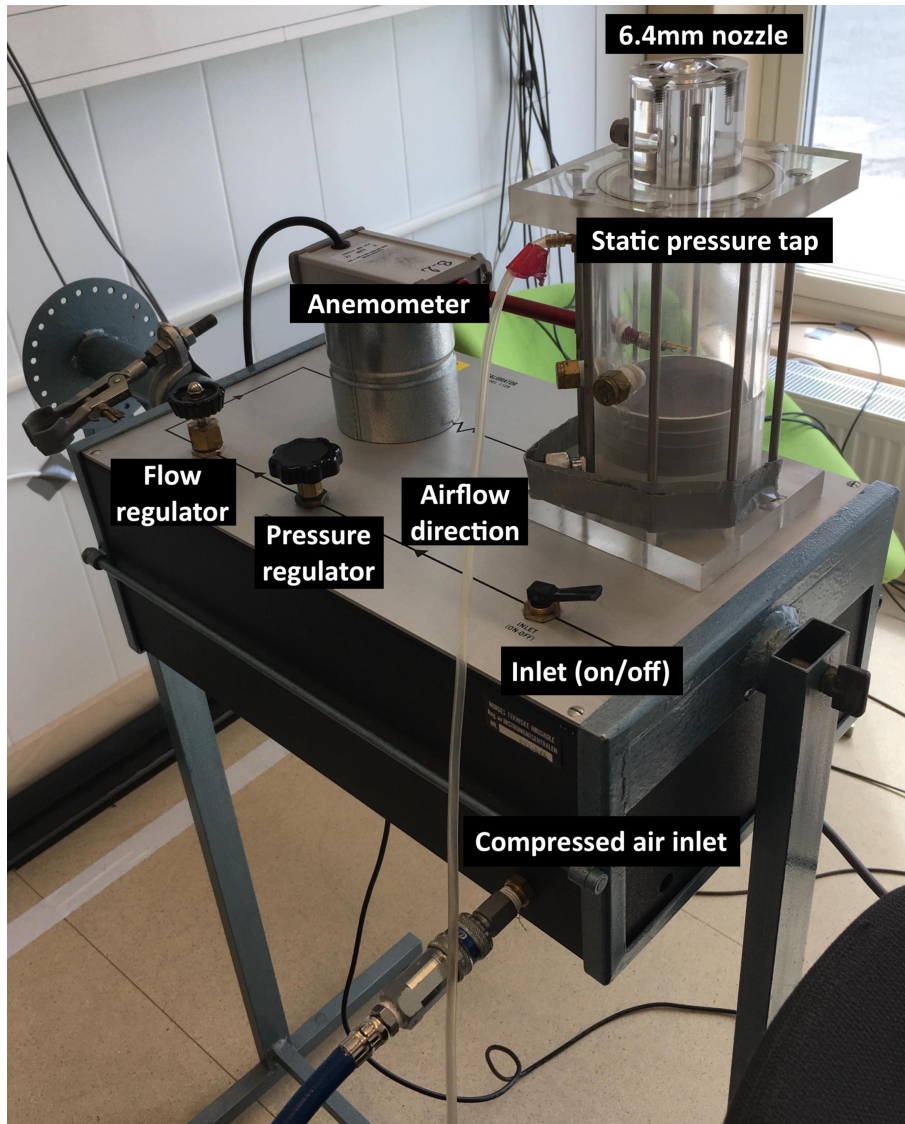

Figure 3.12.: TSI calibrator model 1125. Photo: Stina Skeie.



Figure 3.13.: Manometer. Photo: Stina Skeie.

The air velocities in an indoor space are relatively low. Accordingly, the anemometers were only calibrated for values relevant for this experiment although the range of the given equipment is $0 - 20m/s$. It was important to get frequent measurements for the relevant air velocities. Setpoints for velocity ranged between $0m/s$ and $0.7m/s$ with $0.1m/s$ steps. As described, the air velocity setpoints were correlated to the resulting pressure in Pascal. By doing so one could regulate the airflow until the manometer read the relevant pressure level. Measurements were gathered for approximately one minute at each step. Later an average value was calculated. Air velocities measured were represented with voltage given in $[mV]$ and registered in LabVIEW. After completing measurements for setpoints ranging from $0 - 0.7m/s$ the calibration was continued decreasing setpoints from $0.7 - 0.1m/s$. That was to limit the effect of hysteresis. A value of one variable is dependent on the direction of change of another variable. The results from the calibration can be found in Appendix B.

3.4.5. QUESTIONNAIRE

In order to get valuable feedback from occupants a questionnaire will be used, further divided into three parts. It will be included as a pop-up questionnaire on their computer screen installed as a software. The aim is to reveal occupants actual perception of the thermal environment and be able to analyze correspondence between occupant feedback, measurements and user control.

At the beginning of the day each occupant will report initial conditions and expectations by filling out the first part of the questionnaire. By providing the possibility to tick off relevant garments it will also be possible to determine the insulation value of each participants' clothing. This will be followed up every 30 minutes with another questionnaire to be answered. The aim is to reveal thermal sensation and perception of indoor environmental parameters such as air quality or light level. At the end of the day some final questions will be given describing the day in the test cell. The full questionnaire containing the three different parts as it appears in the software is presented in Appendix C.

3.4.6. PARTICIPANTS

Table 3.3 gives a presentation of the participants of the case study. Gender and age can possibly affect the perception of thermal comfort due to differences in physics and for example metabolism as shown through the literature review. Origin is of importance due to expectations of climate. A native will be well adapted to the cold climate of Trondheim as opposed to an exchange student visiting from a country known for having a moderate or warm climate.

Table 3.3.: Participants of the case study.

Participant	Gender	Age	Origin	Length of stay
1	Female	30	Indonesia	1.5 years
2	Male	36	Poland	4 years
3	Male	26	Italy	4 months

Table 3.4 gives an overview of the arrangement of participants. The study to be completed can be regarded as consisting of two parts. The first part is based on findings from a day worth of data from both test cell A and B. These results are to be presented in Chapter 5.2.1 and Chapter 5.3.1 and include findings on thermal comfort and simulations respectively. This research is referred to as *Study on user control* in Table 3.4. Findings on window user operation gathered from participants occupying test cell A are referred to as *Study on window opening strategies* in Table 3.4. These results are to be presented in Chapter 5.3.2. Note that an *X* in the corresponding table row shows that the cited event of experiment should be used for the listed study.

Table 3.4.: Overview showing arrangement of participants for different parts of the study.

Date	Participant	Test cell	Study on user control	Study on window opening strategies
30.04.18	1	B	X	
30.04.18	2	A	X	X
01.05.18	2	A		X
02.05.18	3	A		X
03.05.18	3	A		X
04.05.18	1	A		X

4. SIMULATIONS OF THE TEST CELL

This chapter intends to present the simulation case study to be completed as a continuation of the field work. The aim of the simulation is to answer the research questions rendered below. Furthermore, a purpose of this chapter is to present the model implemented in IDA ICE in more detail. IDA ICE version 4.7.1 is to be used. As the simulation model to some extent is developed based on the cell office completed during the students specialization project, some data is rendered with no additional explanation as it can be found in Skeies project work from 2017 (Skeie 2017).

- *Do the participants of the case study represent a standard vote in correlation to the PMV model?*
- *To what extent is the energy consumption for heating affected by user behaviour?*

4.1. INPUT DATA TEST CELL MODEL

The model as it appears in IDA ICE is shown in Figure 4.1 and Figure 4.2 with the 3D model and the floor plan respectively. At the ZEB Test Cell Laboratory there are two separated zones adjacent referred to as test cell A and B. In order to more easily simulate differences between the two cells and the operating strategies the two cells have been developed in two separate files. However, the general input data and facade are identical for the two test cells. A shared presentation of important factors follows.

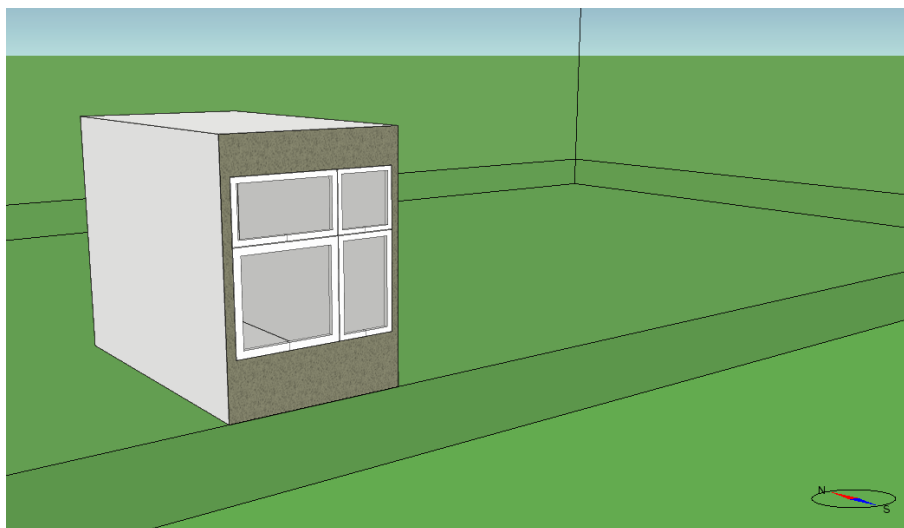

Figure 4.1.: 3D model showing the test cell as implemented in IDA ICE.

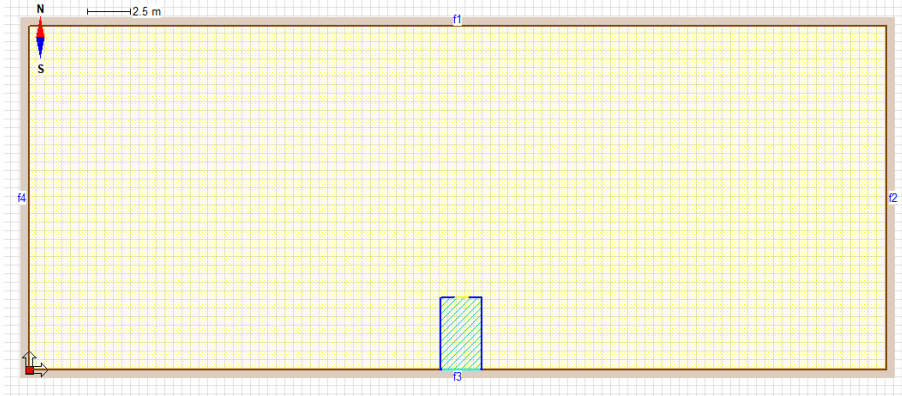

Figure 4.2.: Floor plan of the test cell as it appears in the IDA ICE model.

4.1.1. LOCATION AND CLIMATE

In accordance to the location of the ZEB Test Cell Laboratory, the model in IDA ICE has been though situated in the city centre of Trondheim. The simulation file in IDA ICE will include a climate file from Værnes representing Trondheim. The location has been further modified with accurate coordinates as presented in Chapter 3.3, namely $63^{\circ}41'$ north and $10^{\circ}41'$ east with an altitude of 40 m.a.s.l. (Cattarin et al. 2017). A more thorough description of the climate in Trondheim can be found in Skeie's specialization project from 2017 (Skeie 2017). It has also been specified that the building is located in the city centre, modifying the wind profile.

Based on weather data measured during the experimental work the climate file will be updated. This implies that values measured at the test cell weather station will be swapped with standard values in the climate file. This is to limit errors potentially affecting the results as the outdoor climate is of great importance to this thesis' research aim. However, this will only be done for certain parameters that has been measured and standard values will be used for the remaining parameters. Air temperature, relative humidity, direct normal radiation and wind speed with both an x and y component are the parameters customized in the climate file. For the diffuse radiation and sky cover standard data will be used as this has not been measured.

4.1.2. BUILDING BODY

As can be seen in Figure 4.1 the external surface is faced south. The remaining four surfaces will be defined as internal surfaces. By doing so it is possible to specify that net heat transmission should be ignored. This is an approximation to the environmentally controlled volume surrounding the test cells in the laboratory where temperatures in both environments can be set to identical values.

The layers of the different types of construction are shown in the following tables. The internal walls and the ceiling slab consist of the same layers and are presented together in Table 4.1. The internal wall construction additionally include internal wooden flooring and the properties can be found in Table 4.2. Lastly, the external wall facing south is presented in Table 4.3.

The window element has been included as four separate windows. Each window represents one of the parts of the window delivered by NorDan as can be seen in Chapter 3.4.3 and Figure 3.6. This is an approximation that needed to be done due to limitations in the simulation program. This solution is preferable as each separate window part is correlated to different control strategies and can then more easily be operated individually. The different elements of the window construction are presented in Table 4.4. Then, properties for the window element follows in Table 4.5. An exterior screen has been implemented as integrated window shading to best represent the shading type used at the ZEB Test Cell Laboratory. The exterior blind installed at the facility can be seen in Chapter 3.3 and Figure 3.1.

Table 4.1.: Properties for the construction of internal walls and ceiling slab, Ref.: (Cattarin et al. 2017).

Element of construction (in-out)	Thickness [m]	Thermal conductivity [W/mK]	Density [ks/m ³]	Specific heat [J/kgK]
Steel - galvanized sheet	0.0006	62	7800	500
Polyurethane foam	0.0988	0.024	35	1600
Steel - galvanized sheet	0.0006	62	7800	500

Table 4.2.: Properties for the construction of internal floor, Ref.: (Cattarin et al. 2017).

Element of construction (in-out)	Thickness [m]	Thermal conductivity [W/mK]	Density [ks/m ³]	Specific heat [J/kgK]
Internal wooden flooring	0.15	0.15	1250	1200
Steel - galvanized sheet	0.0006	62	7800	500
Polyurethane foam	0.0988	0.024	35	1600
Steel - galvanized sheet	0.0006	62	7800	500

Table 4.3.: Properties for the construction of external wall faced south,
Ref.: (Cattarin et al. 2017).

Element of construction (in-out)	Thickness [m]	Thermal conductivity [W/mK]	Density [ks/m ³]	Specific heat [J/kgK]
Internal wooden lining	0.012	0.15	1250	1200
Glass-wool layer	0.30	0.035	32	670
Air cavity	0.02	Not applicable	1.2	1007
External cladding	0.005	0.5	1250	1200

Table 4.4.: Properties for the construction of the window element.

Element of construction (in-out)	Thickness [m]
Low-E coating	4
Argon gap	16
Float glass	4
Argon gap	16
Low-E coating	4

Table 4.5.: Properties for the test cell window element.

Properties	Unit	Value
Total width	[m]	2.188
Total height	[m]	2.088
Total window area	[m ²]	4.57
Frame fraction of window area	[%]	26.7
Frame U-value	[W/m ² K]	1.45
Glazing U-value	[W/m ² K]	0.568
Overall U-value	[W/m ² K]	0.8035
g-value	[–]	0.212
Visible transmittance	[%]	44.1

4.1.3. KEY DATA

Some key data implemented in the simulation model is presented in Table 4.6. The ventilation system is balanced and implemented as CAV, constant air volume, with an air flow rate of $2L/sm^2$. The temperatures are fixed and can not be changed for heating and cooling purposes by the occupant. The radiator is the only heating supply, if the internal heat gains are not taken into consideration. The maximum setpoint temperature is $25^{\circ}C$ and minimum setpoint temperature is $21^{\circ}C$, whereas temperature throttle is $2^{\circ}C$. The waterbased radiator is controlled in regards to the zone air temperature measured by a sensor. Following, a valve regulates the volume flow of the water. The radiator has been placed in the cell office model beneath the window. That is to make sure that heat losses between the radiator and backside of the facade wall is taken into consideration as would be the case in the ZEB Test Cell Laboratory.

Table 4.6.: Key data implemented in the simulation model.

Parameter	Unit	Value
Internal dimensions test cell $W * L * H$	$[m * m * m]$	2.4 * 4.2 * 3.3
Normalized thermal bridge value	$[W/m^2K]$	0.05
Ventilation rate CAV	$[L/sm^2]$	2
Installed effect for room lighting	$[W]$	56*3 light fixtures
Installed effect for desk lighting	$[W]$	35
Installed effect for equipment	$[W]$	132

4.1.4. CITE SHADING

Shading from nearby buildings and trees has been taken into consideration in order to replicate the test cell location. Figure 4.3 shows an aerial photo of the ZEB Test Cell Laboratory and its surroundings. The main building causing shading, SINTEF Building and Infrastructure, and some nearby trees have been included in the model as cite shading. This can be seen in Figure 4.4. The implemented shading representing the building is set to having a transparency of 0%. In order to take into account the current season, where the trees have less leaves, a transparency of 25% was set for this shading.



Figure 4.3.: Aerial photo of the ZEB Test Cell Laboratory and nearby surroundings, Ref.: (*Google Maps*).

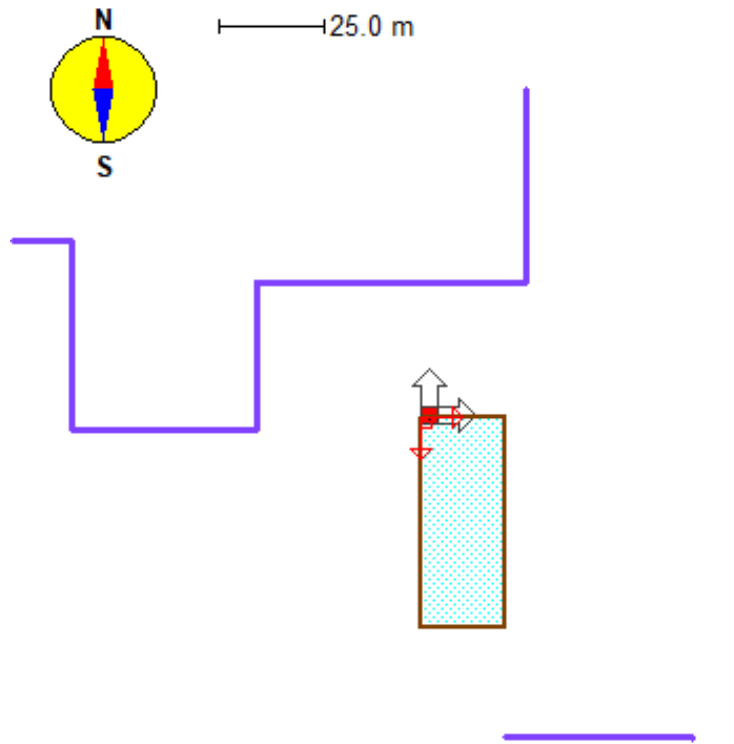

Figure 4.4.: Cite shading as implemented in IDA ICE.

4.2. CONTROL STRATEGIES

The aim is to analyze control strategies. As described when presenting the experimental work, one test cell will provide manual control whilst the other is computer operated. The following subchapters presents these controls in more detail.

4.2.1. TEST CELL A

Test cell A will be optimized in terms of thermal comfort and not energy performance, as the occupant is provided with the possibility to control every element except the ventilation system. A more detailed overview of the control strategies for test cell A is given in Table 4.7. As all these control strategies are user operated, the implementation of the occupant behaviour will be done as schedules based on registered actions from the field work. The modeling of this case study is presented in Chapter 4.3. The ventilation system is the only factor the user can not affect, and has been implemented as described in Chapter 4.1 on input data.

Table 4.7.: Control strategies for test cell A.

Element	Control strategy
Top window	User operated with motorized switch. Open/close.
Bottom window	User operated via handle.
Desk light	User operated via switch. On/off.
Room light	User operated via switch. On/off.
Radiator thermostat	User operated thermostat setting.
External shading screen	User operated with motorized switch. Open/close.
Ventilation rate	Fixed at $2L/sm^2$

4.2.2. TEST CELL B

The control strategies for operation of test cell B are intended to optimize both thermal comfort and energy performance. The control strategies for test cell B are presented in Table 4.8. Use of automatic controls assures that the equipment operates as effectively as possible. As for test cell A, the control that is user operated, here desk light, will be implemented as a schedule further described in Chapter 4.3. The elements that are computer operated have been implemented as custom controls in the program and a presentation of these follows.

Table 4.8.: Control strategies for test cell B.

Element	Control strategy
Top window	Computer operated and opens if $T_a > 25^\circ\text{C}$. Open/close.
Bottom window	Always closed.
Desk light	User operated via switch. On/off.
Room light	Computer operated and is turned off when desk lux meter reads above $600lux$. On/off.
Radiator thermostat	Fixed at 21°C .
External shading screen	Computer operated and is closed if desk lux meter reads above $3000lux$. Open/close.
Ventilation rate	Fixed at $2L/sm^2$

The custom controls in IDA ICE are implemented as block diagrams. A block diagram is a graphical representation of a model. It gives a structural overview where the lines connecting the boxes represents a signal being sent.

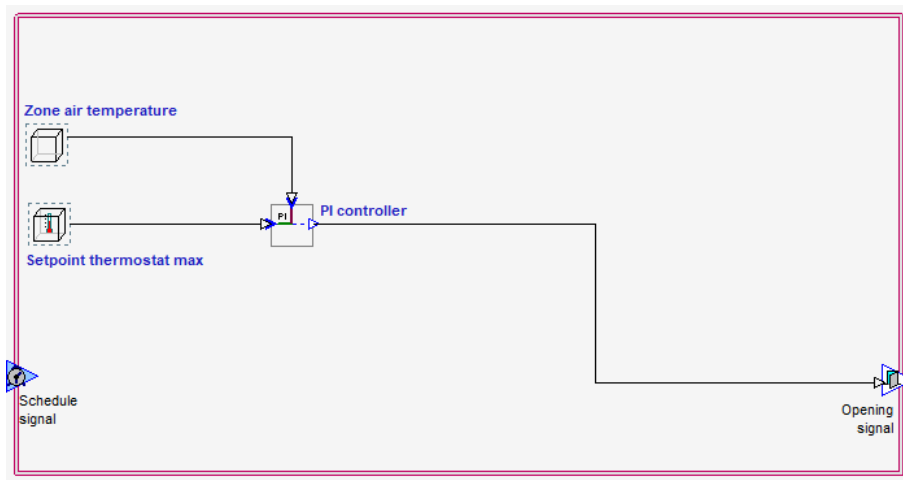

Figure 4.5.: Top window opening strategy control as implemented in IDA ICE.

The window opening control as it appears in IDA ICE is shown in Figure 4.5. The block representing a PI controller will give output signals ranging from 0 to 1. A closed window is represented with the value 0, whilst 1 will give a fully opened window. If the temperature in the zone becomes higher than the maximum allowed temperature set by a constant, the window will open gradually due to the PI-controller. The aim is to keep the temperature in the zone at the preferred temperature. If the zone temperature is lower than the setpoint temperature, the output signal is 0 and the window will be kept closed.

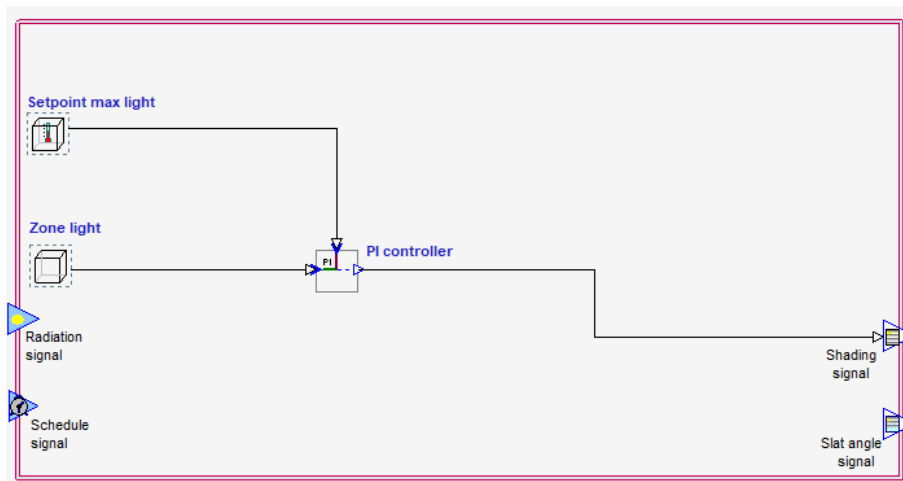

Figure 4.6.: External shading screen draw control as implemented in IDA ICE.

A PI controller has been implemented in order to operate the external screen, as seen in Figure 4.6. The registered lux level in the zone is compared to the maximum setpoint at 3000lux . The screen will be drawn if the measured value exceed the setpoint in order to minimize glare and overheating.

The room light fixtures placed in the ceiling should turn off if the lux meter reads above 600lux . This has been obtained by setting the control strategy to include both setpoints and a schedule, where the schedule is always on during the time of the simulation. The setpoints are defined at the general cite of the implemented zone under controller setpoints.

4.3. SIMULATION CASE BASED ON REGISTERED USER BEHAVIOUR

Based on results from the experimental work, user behaviour will be implemented in the simulation models in more detail. The main aim is to compare the case of the participating occupants to an average predicted person as can be simulated in IDA ICE with Fanger’s comfort index PMV. User behaviour will be implemented into IDA ICE with schedules. This is regarded as an efficient method as sensors registered in LabVIEW show at what time the different operation strategies have been applied. Occupants also define what changes they have made to their work environment through the questionnaires repeated every half an hour.

Participants describe their clothing through the questionnaire. Based on this feedback the clothing level measured in $[clo]$ can be determined by using standard NS-EN ISO 7730. Annex C in the given standard include tables that can be used for estimation of thermal insulation of clothing ensembles (Norsk Standard, NS-EN ISO 7730 2006). Thermal insulation is given for typical garments in table C.2. Values can be summarized directly to find the total $[clo]$ value based on the garments the participants have ticked off by filling out the questionnaire. Note that underwear except socks has been neglected from the questionnaire. It could be a limitation setting a constant $[clo]$ value as occupants might take a layer on or off during the day. However, through the questionnaire it has been registered that this was not the case the current day and a constant value can be set uncritically. Annex B in standard NS-EN ISO 7730 presents metabolic rates of different activities. The activity level is set to be 1.2met according to the sedentary work at an office desk (Norsk Standard, NS-EN ISO 7730 2006).

In correlation to the plan as presented in Chapter 3.4.6 and Table 3.4, the first day of the experiment should be used for this part of the study on user control. Namely the 30.04.18. This implies that participant 1 occupied test cell B and participant 2 test cell A accordingly.

4.3.1. TEST CELL A

Table 4.9 show values of importance as implemented in IDA ICE.

Table 4.9.: Key data for the participant in test cell A.

Parameter	Unit	Value
Clothing insulation	$[clo]$	0.38
Activity level	$[met]$	1.2

Schedules correlated to the different elements affected by the user are given in the following figures. That is occupancy in Figure 4.7, top window operation in Figure 4.8, bottom window operation in Figure 4.9, desk light in Figure 4.10, room light in Figure 4.11 and external shading screen in Figure 4.12. Note that the occupant had both ceiling and desk light turned off the entire workday. A noted reason for this was that no artificial lights was needed due to only doing work on the computer.

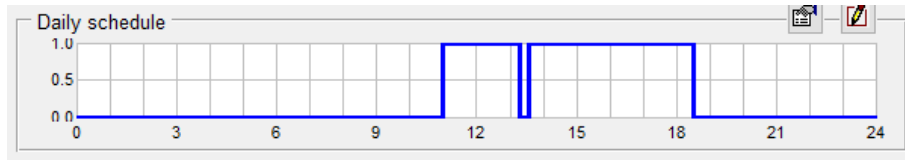

Figure 4.7.: Schedule for occupancy in test cell A.

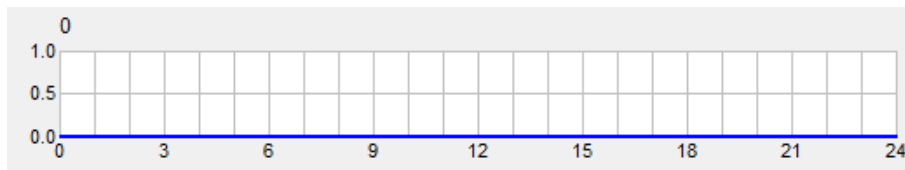

Figure 4.8.: Schedule for opening of the top window in test cell A.

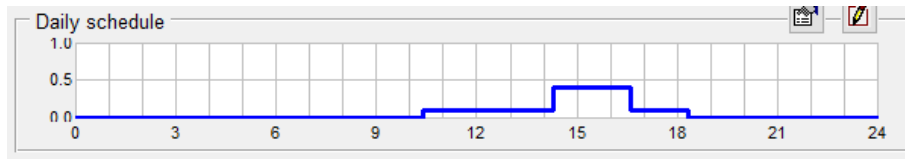

Figure 4.9.: Schedule for opening of the bottom window in test cell A.

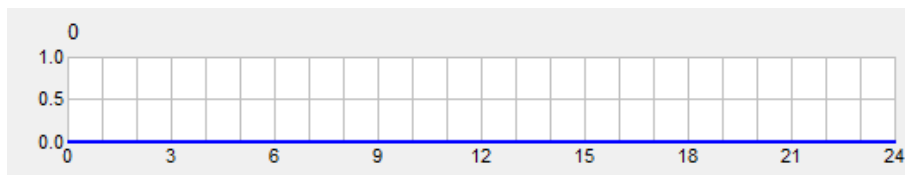

Figure 4.10.: Schedule for desk light in test cell A.

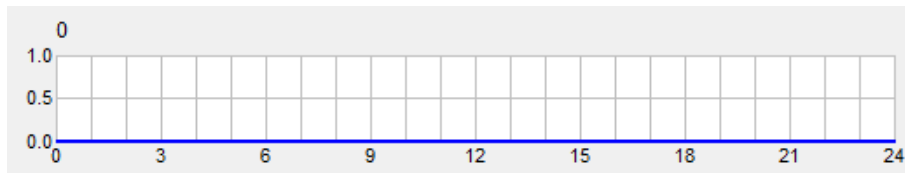

Figure 4.11.: Schedule for room light in test cell A.

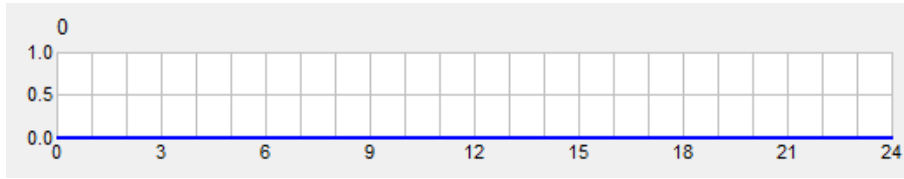

Figure 4.12.: Schedule for shading screen in test cell A.

4.3.2. TEST CELL B

Table 4.10 include a list of values relevant to the participant in test cell B as implemented in IDA ICE.

Table 4.10.: Key data for the participant in test cell B.

Parameter	Unit	Value
Clothing insulation	[clo]	0.54
Activity level	[met]	1.2

Schedules correlated to the user operated control and occupancy are given in the following figures. That is occupancy in Figure 4.7 and desk light in Figure 4.10. Note that the desk light was turned on that entire day both before, during and after occupancy.

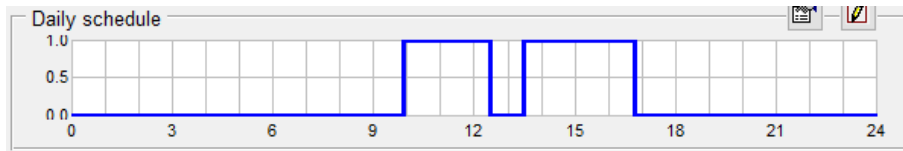

Figure 4.13.: Schedule for occupancy in test cell B.

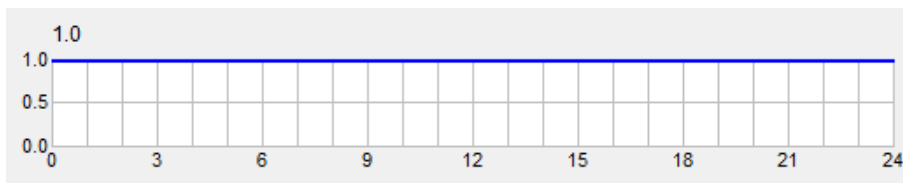

Figure 4.14.: Schedule for desk light in test cell B.

4.4. USER BEHAVIOUR EFFECTS ON ENERGY USE

It is of interest to analyze user behaviour in terms of energy use as this has been shown to be of great influence through the literature review. This will be done specifically on window operation. As for the case study the two parts of the window referred to as *aa* and *da*, see Figure 3.6, will be operated. The two remaining window parts will be held closed at all times. Four different window opening strategies should be developed and simulated.

The building model will be the test cell as throughout this study, and the remaining control strategies is computer operated as for test cell B. This implies that room light, radiator and shading will be operated as described in Table 4.8, whilst desk light will be assumed always on during occupancy. This is to focus on the effect of window operation.

Clothing level values in correlation to the thought occupant will be as presented in Table 4.11. It represents how the different participants has dressed each day. Annex C and table C.2. in standard NS-EN ISO 7730 has been used to find the total [*clo*] value based on the garments the participants have ticked off by filling out the questionnaire each of the five days. It will be included in the IDA ICE model with a customized schedule defining the different values as presented in Table 4.11 in regards to the current date. The activity level is set to 1.2met according to standard NS-EN ISO 7730 Annex B (Norsk Standard, NS-EN ISO 7730 2006).

Table 4.11.: Clothing insulation value as implemented in IDA ICE.

Date	Clothing insulation [<i>clo</i>]
30.04.18	0.38
01.05.18	0.38
02.05.18	0.58
03.05.18	0.33
04.05.18	0.38

Schedules defining occupancy as registered throughout the five days of experiments has been included in IDA ICE. These schedules will be used when simulating all four window operating strategies ensuring similar conditions. Note that only the main lunch break of the day has been included. Smaller toilet breaks on less than five minutes has not been taken into account. It is reasonable to assume that conditions in the cell does not change due to such lack of occupancy as the participants returned shortly after.

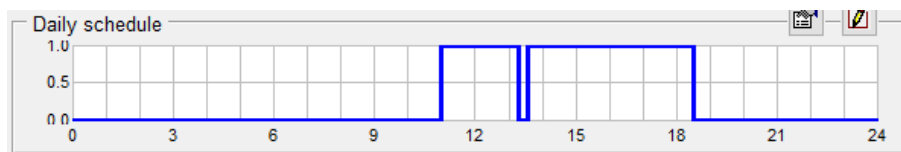

Figure 4.15.: Occupancy manual cell 30.04.18.

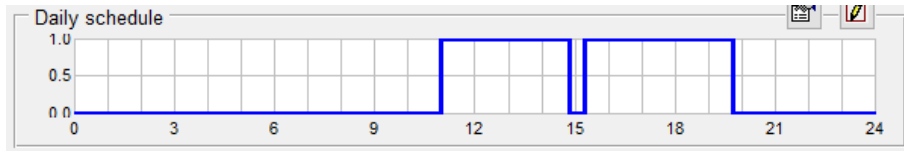

Figure 4.16.: Occupancy manual cell 01.05.18.

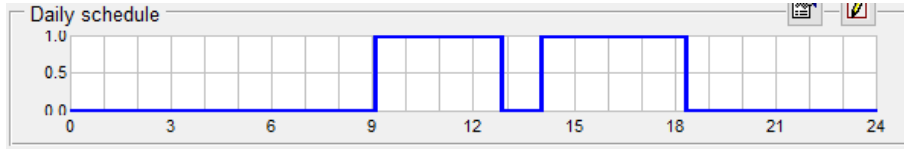

Figure 4.17.: Occupancy manual cell 02.05.18.

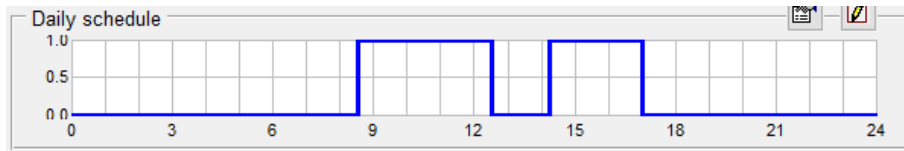

Figure 4.18.: Occupancy manual cell 03.05.18.

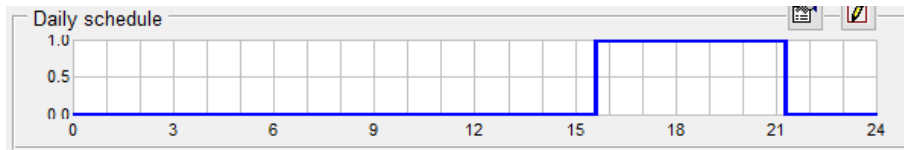

Figure 4.19.: Occupancy manual cell 04.05.18.

4.4.1. WINDOW OPENING OF THE NORDAN PANE

The window from NorDan installed in the test cells contains four windows parts, as shown in Chapter 3.4.3 and Figure 3.6. As described, only part *aa* and *da* will be possible to open during the period of the experiment. Figure 4.20 and Figure 4.21 below show the opening strategies for the two operable windows. Window part *da* can be opened two ways, both as a side hung casement and bottom hung. The window size in width and height accordingly is $1400mm * 788mm$. The top part *aa* only opens as a bottom hung window and has a total area of $788mm * 1300mm$.

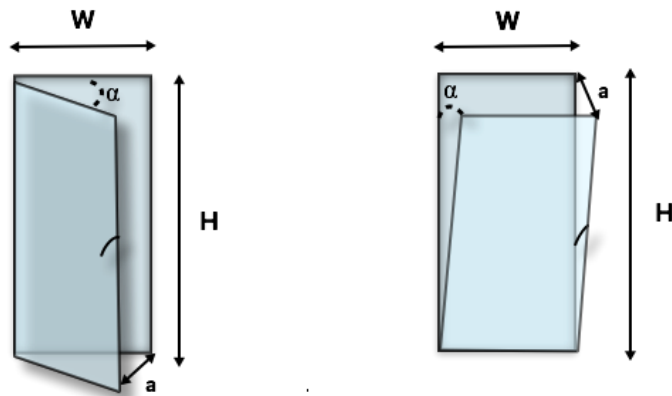

Figure 4.20.: Window part *da* with both opening strategies; side hung casement to the left and bottom hung at the right. Photo: Stina Skeie.

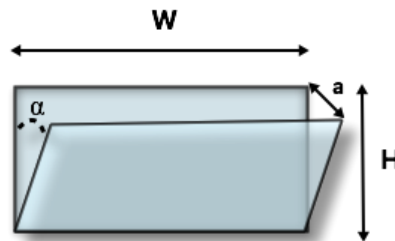

Figure 4.21.: Window part *aa* opening strategy; bottom hung. Photo: Stina Skeie.

Sensors are installed on the windows in order to easily register if the windows are opened or not. Figure 4.22 shows the bottom window, and the sensors are accentuated with the encircling red boxes. A close up of one of the sensors is shown in Figure 4.23. As the bottom window can open two ways, both tilted inwards as a bottom hung and as a side hung casement, two sensors are installed. If only the sensor placed on the upper side of the window register opening then the window is opened as a bottom hung. Accordingly, if both sensors register window opening the occupant has opened the window as a side hung casement. The top window only tilts inwards and have one sensor installed at the upper part of the window frame. The sensors only register if the windows are open or not, they do not register the degree of window opening.



Figure 4.22.: Sensors registering window opening marked with the red boxes.
Photo: Stina Skeie.



Figure 4.23.: Closeup of the window opening sensor. Photo: Stina Skeie.

The opening area will have the same shape for all the three window openings. All windows are attached to its frame at one side. Furthermore, all windows open inwards. The opening area will consist of one rectangle as well as the two triangles due to the tilted window. The triangles can be calculated using Heron's formula where three sides are known. Thus, the total opening area could be calculated using Equation 4.1. Symbols used in the equation are based on the sketch of the side hung window in Figure 4.20.

$$A_{opening} = a * H + 2 * \sqrt{s(s - W)(s - W)(s - a)},$$

$$\text{where } s = \frac{W + W + a}{2} \quad (4.1)$$

List of symbols:

- $A_{opening}$ is the area of window opening measured in $[m^2]$
- H is the height of the window in $[m]$
- W is the width of the window in $[m]$
- a is the tilt width of window opening in $[m]$

As initiated in Skeie's project work a definite limitation is how IDA ICE defines window opening (Skeie 2017). For calculations in IDA ICE a fully opened window is represented with 100% and equals an effective area where the width and height of the window is multiplied with a discharge coefficient. If the window opening is reduced to 50%, then so is the effective area. As shown, both operable windows are tilted when opened and the area will be dependent on the angle between its current position and the frame placement as defined in Equation 4.1. Implying that a window opening percentage should rather be defined as the open area when the window is positioned at a given angle divided by the area of the window. As stated, the sensors do not register how large the opening is, only if the window has been opened or not. In order to apply the formula in Equation 4.1 the tilt width of the window opening is needed as an input. It would improve accuracy and concurrence between the laboratory experiment and simulations to define window opening with a model that take the tilted position into consideration. However, as a result of the noted limitation in the window setup then hereafter window opening will be defined as a percentage according to the CELVO model applied in IDA ICE (Axel Bring 1999). This simplified formula is given in Equation 4.2. The discharge coefficient is a default value set to 0.65.

$$A_{eff} = c_d * A_{opening} = c_d * W * H \quad (4.2)$$

List of symbols:

- $A_{opening}$ is the area of window opening measured in $[m^2]$
- A_{eff} represents the effective area of window opening in $[m^2]$
- c_d is the discharge coefficient [-]
- W is the width of window opening in $[m]$
- H is the height of window opening given in $[m]$

4.4.2. MODELED USER BEHAVIOUR

The aim of this part of the study is to see how mainly energy use for heating, but also how quality of indoor air and thermal comfort vary based on user behaviour. Some subconsciously ventilates their work place or home more than others always having their windows open. Other keep them closed at all times whilst some fully open the windows at preset times during the day due to old habits or settled policies regardless of environmental factors. That could be due to a concern of mould growth or dust mites and the corresponding health effects, and are not driven solely by comfort. Another tendency could be that window opening depends on the weather and season. A high indoor temperature will lead the occupant to open the windows during warmer seasons or in sunny weather. In rainy or cold weather the windows might be held closed regardless of the high indoor temperature. There are of course many nuances between the extreme cases. This behaviour is difficult to anticipate during the planning stages and the effects can be great.

Four different cases of window operation will be analyzed. These control strategies are intended to imitate different user behaviour and each case represents one thought persons way of operating the windows. The cases that should be further studied are listed below. Furthermore, a presentation of the control strategies as implemented in IDA ICE follows. In order to compare the energy consumption for heating between the different window opening strategies, the setpoints for the radiator temperature will remain the same for all models. This implies that the maximum setpoint temperature is 25°C and minimum setpoint temperature is 21°C. Temperature throttle is 2°C.

Control strategies representing user behaviour:

- Strategy 1** Windows always open
- Strategy 2** Windows always closed
- Strategy 3** Windows operated based on season, indoor and outdoor temperature and CO_2
- Strategy 4** Windows operated based on registered opening strategies in test cell A

As one of the strategies should be based on registered user behaviour from the field work, simulations will cover the exact same days as the period of the data collection, namely 30.04.18 to 04.05.18. That is to easily be able to compare the different strategies' affects on energy use and simultaneously minimize uncertainties. If whole year simulations were to be completed, the climatic and environmental parameters would not be within the range of the determining factors as revealed during the experimental work.

Window opening strategy 1

The first case represents a person always having the windows open during working hours. When arriving at the office the window is opened and kept at that position until the end of the workday. The window opening is limited to 10% and with that one obtains a consistent and permanent slot ventilation. The easiest way to implement such a simple control in IDA ICE is to include a schedule for window opening. A different schedule has been included for each of the five days as arrival and departure varied. A window opening of 10% is constant during occupancy. The window opening area for a 10% opening is given in Table 4.12, and obtained by using Equation 4.2 presented in Chapter 4.4.1.

Table 4.12.: Window opening area for strategy 1.

Window	Window opening [%]	Window area W*H [m * m]	Window opening [m ²]
Bottom window	10	1.4*0.788	0.072
Top window	10	0.788*1.3	0.067

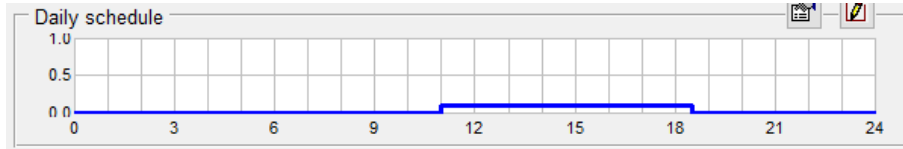

Figure 4.24.: Schedule implemented in IDA ICE representing window opening strategy 1 30.04.18.

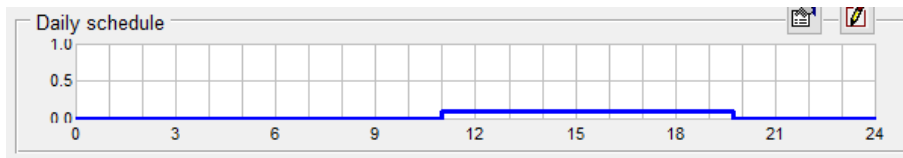

Figure 4.25.: Schedule implemented in IDA ICE representing window opening strategy 1 01.05.18.

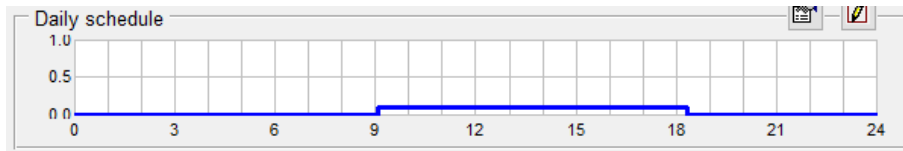

Figure 4.26.: Schedule implemented in IDA ICE representing window opening strategy 1 02.05.18.

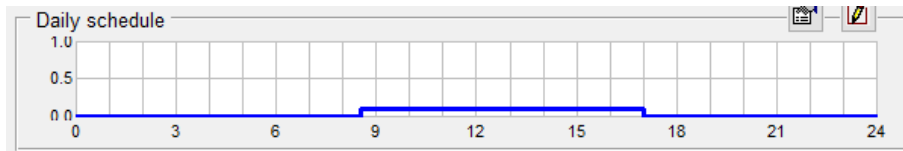

Figure 4.27.: Schedule implemented in IDA ICE representing window opening strategy 1 03.05.18.

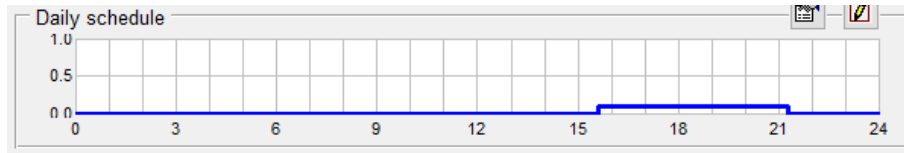

Figure 4.28.: Schedule implemented in IDA ICE representing window opening strategy 1 04.05.18.

Window opening strategy 2

The extreme case of having the windows always closed is a default value available in IDA ICE. As a control for opening it is possible to choose the windows to be never open.

Window opening strategy 3

Regarding case number 3 a custom control needs to be implemented. This window control has been developed with the intention of considering climatic variations resulting in both summer and winter operation as well as night-time ventilation. This is a more complex window opening strategy than presented with the intended user behaviour in number 1 and 2. It is of interest to analyze a more varied window operation. It is reasonable to assume that some base their use of window ventilation on more than one factor and that it variate on a day to day basis. This thought occupant will not only open windows due to a high indoor temperature, but also if the indoor air quality should become lower. If the outdoor temperature is too low the window opening is minimized or fully closed. That is to reduce discomfort due to draft or large temperature variations. However, this might lead to discomfort due to accumulation of CO_2 . Therefore, a special control is included because if windows are held closed due to a low outdoor temperature the CO_2 level in the zone could rise to a critical level. This will reduce quality of indoor air, potentially also reducing performance of work. Thus, pulse ventilation has been included imitating a situation where the occupant focuses ventilation to a limited time period due to a low outdoor temperature. This is typically done simultaneously as leaving the room for a short period of time.

The custom control as it appears in IDA ICE is shown in Figure 4.29. The winter operation has been included as a macro with the aim of giving a clear overview of the control due to lack of space in the program window. This can be seen in Figure 4.30. Windows will open gradually if the temperature in the zone become higher than $21^\circ C$. Night-time ventilation ensures that thermal mass is cooled down in order to minimize overheating the following day. This is applied if the outdoor temperature is higher than $12^\circ C$, and the maximum window opening has been set to 50%. A wider opening is not preferable due to safety reasons. During daytime windows can be opened up to 100% if the outdoor temperature is higher than $12^\circ C$. If not then pulse ventilation is applied according to a schedule. Accumulation of CO_2 is minimized as windows open if the concentration exceed $800ppm$. The window opening is limited to 10% and 5% as the outdoor temperature is higher or lower than $12^\circ C$ respectively. Note that a more thorough description of the window control can be found in Skeie's specialization project from 2017 (Skeie 2017). The window opening area correlated to a given percentage of window opening is given in Table 4.13 and Table 4.14 for the bottom and top window respectively. Equation 4.2 presented in Chapter 4.4.1 have been used for the calculations.

Table 4.13.: Bottom window opening area for strategy 3.

Control strategy	Window opening [%]	Window area W*H [$m * m$]	Window opening [m^2]
Daytime	100	1.4*0.788	0.720
Pulse ventilation	100	1.4*0.788	0.720
Night-time ventilation	50	1.4*0.788	0.360
Slot ventilation $T_{out} > 12^\circ\text{C}$	10	1.4*0.788	0.072
Slot ventilation $T_{out} < 12^\circ\text{C}$	5	1.4*0.788	0.036

Table 4.14.: Top window opening area for strategy 3.

Control strategy	Window opening [%]	Window area W*H [$m * m$]	Window opening [m^2]
Daytime	100	0.788*1.3	0.670
Pulse ventilation	100	0.788*1.3	0.670
Night-time ventilation	50	0.788*1.3	0.330
Slot ventilation $T_{out} > 12^\circ\text{C}$	10	0.788*1.3	0.067
Slot ventilation $T_{out} < 12^\circ\text{C}$	5	0.788*1.3	0.033

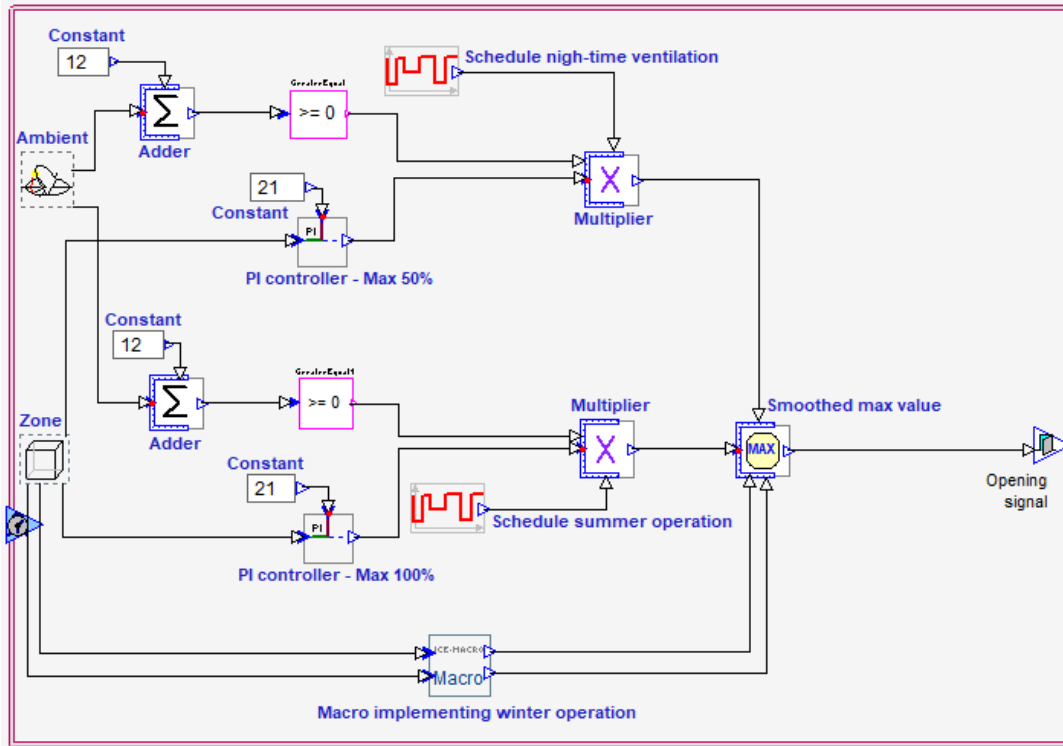

Figure 4.29.: Window control as implemented in IDA ICE.

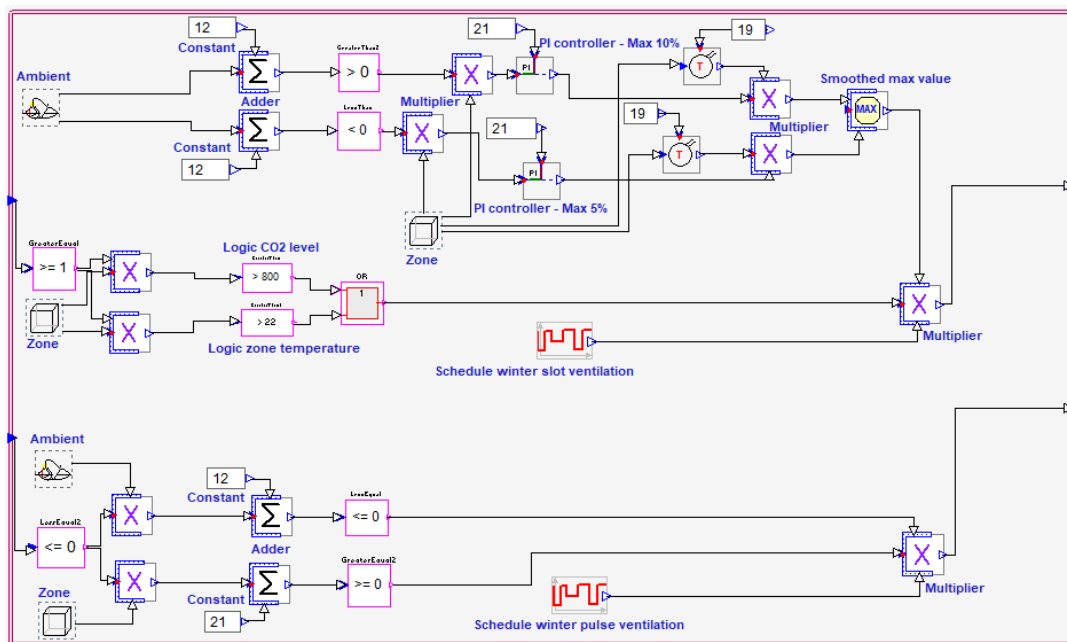

Figure 4.30.: Window control as it appears in the macro for winter operation in IDA ICE.

Window opening strategy 4

The fourth opening strategy has been developed based on user behaviour registered during the experiment in test cell A. That is as cell A provide user feasibility to control the indoor environment, whilst cell B is automatically computer operated. Simulations will, as mentioned, be completed on the exact days of data collection. That implies 30.04.18 to 04.05.18.

Sensor measurements will be used to reveal window opening events and the opening method that has been applied. That is side hung casement or bottom hung window. As this fourth strategy has been developed based on monitoring real behavioural patterns the validation of the simulation will increase accordingly. That is compared to the three other strategies implemented that have been developed solely on presumed user behaviour.

A more detailed model would preferably include the percentage of window opening more accurately. That is not possible however due to the setup in the ZEB Test Cell Laboratory, as described in Chapter 4.4.1. In order to make the model more precise a fixed percentage of window opening has been correlated to the opening methods as presented in Chapter 4.4.1. That is side hung casement and bottom hung. The fixed values can be found in Table 4.15. For the bottom hung window that tilts inwards this is somewhat accurate having chosen a relevant value. For the side hung casement however, the range of window positions when opened are more varied. A fixed value of 40% has been chosen as it is reasonable to assume that the window is opened wider than for the bottom hung strategy set to 10%. That is because the window is often opened as a side hung casement if a wider opening is preferred. This solution of setting fixed opening percentages is more accurate than solely focusing on an opening event as the installed window has two parts possible to open different ways. Although, the discharge coefficient, c_d , will in reality change as the degree of window opening changes and also the opening method. This has not been taken into consideration. The window opening percentage has been correlated to window opening area in Table 4.16. Equation 4.2 presented in Chapter 4.4.1 have been used when calculating the listed opening areas.

Table 4.15.: Percentage of window opening for the two different opening methods.

Window opening method	Window opening [%]
Bottom hung	10
Side hung casement	40

Table 4.16.: Window opening area for strategy 4.

Window	Window opening method	Window opening [%]	Window area W*H [m * m]	Window opening [m ²]
Bottom window	Side hung casement	40	1.4*0.788	0.287
Bottom window	Bottom hung	10	1.4*0.788	0.072
Top window	Bottom hung	10	0.788*1.3	0.067

The opening events as registered during the experiment has been included in IDA ICE. This has been done as schedules for the relevant days and the two different operated windows.

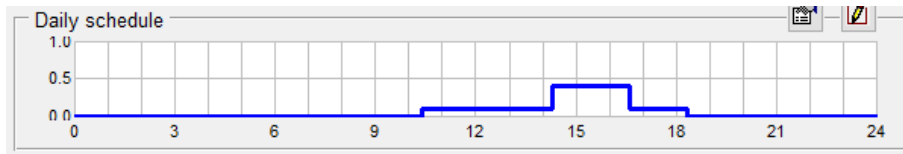

Figure 4.31.: Bottom window operation 30.04.18.

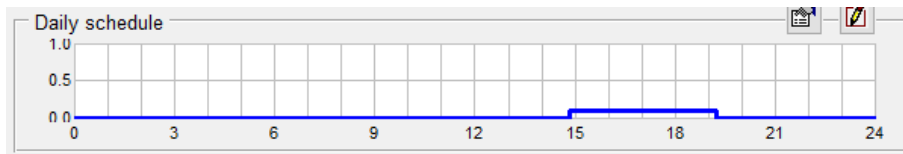

Figure 4.32.: Bottom window operation 01.05.18.

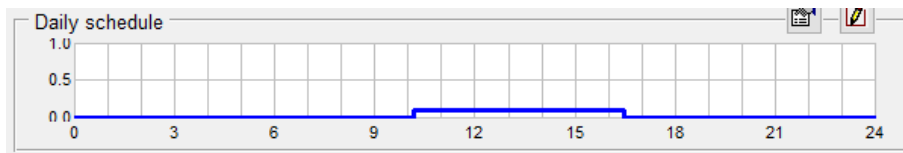

Figure 4.33.: Bottom window operation 02.05.18.

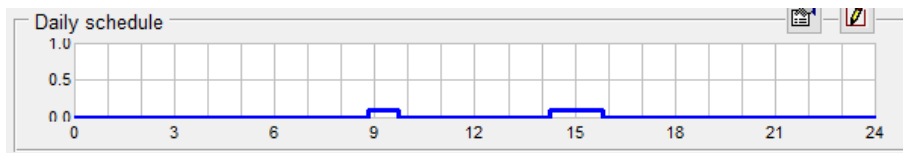

Figure 4.34.: Bottom window operation 03.05.18.

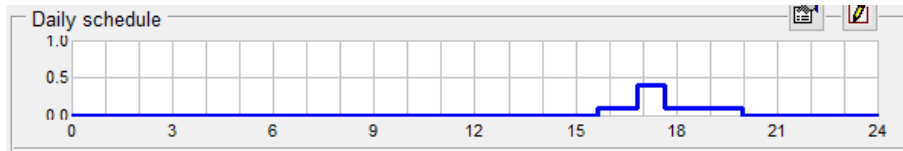

Figure 4.35.: Bottom window operation 04.05.18.

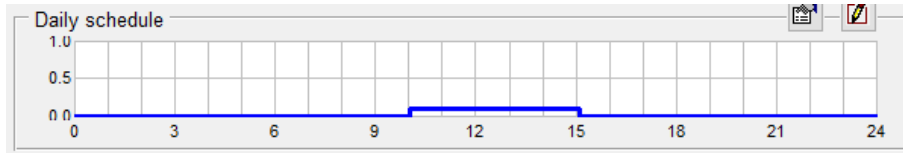

Figure 4.36.: Top window operation 02.05.18.

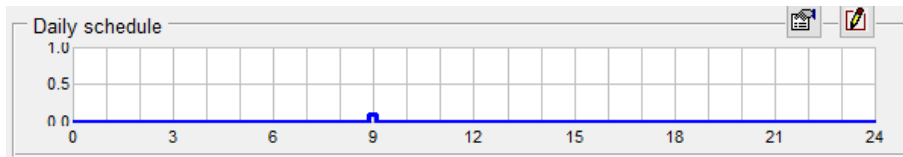

Figure 4.37.: Top window operation 03.05.18.

In addition to the simulations on window operating strategies, an equation that states a window opening event will be developed. A more thorough description of the method to be carried out and results follow in Chapter 5.4

5. RESULTS AND DISCUSSION

The aim of this chapter is to present results gathered by completing the field work and simulations. It can be seen in connection with the research questions given in Chapter 1.2.1. Discussion will follow linking the practical work, the simulations and relevant literature.

5.1. PLANNED EVALUATION OF RESULTS

The results will be analyzed in terms of thermal comfort and indoor air quality, as well as energy use for heating. Due to the low number of participants the experiment and further research will be looked at as a case study.

Sensor measurements will be used when evaluating the feedback gathered from questionnaires. The neutral temperature will be obtained from the questionnaires as occupants rate indoor conditions using the seven-point thermal sensation scale. Based on the graph in Figure 5.1 the predicted optimal operative temperature can be obtained based on the occupants' clothing- and activity level. It is of interest to compare this optimal temperature to the measured temperatures at the test cell rated as acceptable by the participants. Note that the graph highlights a case relevant to an office work situation where the clothing level is 0.5clo and the activity level is 1.2met . This results in an optimal operative temperature of approximately 24.5°C .

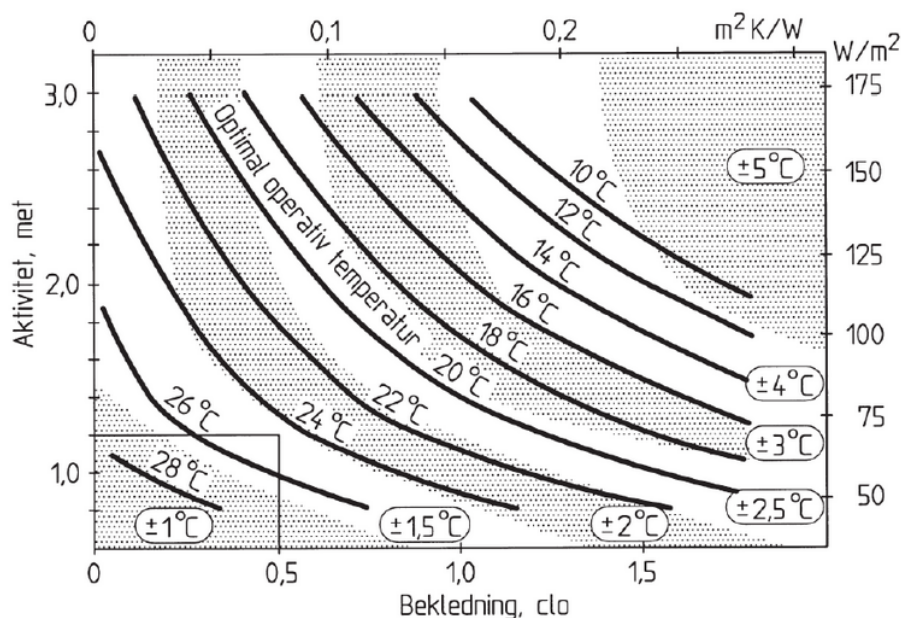

Figure 5.1.: Optimal operative temperature in regards to activity- and clothing level, Ref.: (NTNU SINTEF 2007).

Accordingly, Table 5.1 presents design values for the operative temperature as given in standard NS-EN 15251. The values apply to a cell office and desk top work at 1.2met . Based on the feedback from occupants the perceived comfort temperatures can be compared to standard values as arranged in the different comfort categories.

Table 5.1.: Design values for operative temperature according to NS-EN 15251.

Category of thermal comfort	Lowest operative temperature during winter [$^{\circ}\text{C}$]	Highest operative temperature during summer [$^{\circ}\text{C}$]
	21.0	25.5
	20.0	26.0
	19.0	27.0

The results from the field study should be compared to simulation results. It is of interest to see if the two occupants represent an average predicted vote in accordance with the following research question. Do the participants of the case study represent a standard vote in correlation to the PMV model? Results from the questionnaires and simulations on thermal sensation will be viewed in correlation to PMV according to standard NS-EN ISO 7730. Annex E and the corresponding tables in NS-EN ISO 7730 can be used to determine the predicted mean vote to see if this correspond to findings obtained from questionnaires and IDA ICE (Norsk Standard, NS-EN ISO 7730 2006).

Sensors installed in the test cell measures among other things air temperature, radiant temperature and air velocity. The setup for these sensors can be seen in Figure 3.8 presented in Chapter 3.4.3. Where there are more than one sensor measuring the same parameter, mean values will be calculated and further used. The data on air temperature, radiant temperature and air velocity will be used to calculate the operative temperature as this is an important measure of thermal comfort. Following, the operative temperature will be used when analyzing thermal comfort and presenting relevant results. The calculation method in order to obtain the operative temperature is presented in Equation 5.1.

$$T_{op} = \frac{T_{mr} + T_a * \sqrt{10 * v}}{1 + \sqrt{10 * v}} \quad (5.1)$$

List of symbols:

- T_{op} is the operative temperature in [$^{\circ}\text{C}$]
- T_a is the air temperature in [$^{\circ}\text{C}$]
- T_{mr} is the mean radiant temperature in [$^{\circ}\text{C}$]
- v is the air velocity in [m/s]

The anemometers measuring air velocity were calibrated just after the experiment was completed, in order to limit uncertainties in gathered data. This process is described in Chapter 3.4.4 and results can be found in Appendix B. The regression was obtained by analyzing instantaneous data, and then applied to average data. The instantaneous

data was given by the last registered value noted every 60 second, and the average data represents the average of the 200 previous values. At low air velocities the noise resulted in negative values. That is because the noise was higher than the registered air velocities. The negative part can be regarded as an error. In order to limit this effect the measured values lower than zero was set to zero. This was done for all six anemometers. Afterwards, the average value between the three sensors in both cells was calculated for each time step. This resulted in more realistic data. At low air velocities, as those measured in the test cells, the parameter will have limited impact on the operative temperature, which as a result becomes the mean value of the air- and radiant temperature. The air velocity should be included regardless, however the potential error does not have as great of an impact on the end results. Data was logged for 24 hours each day. For the time period where participants were occupying the test cells, there were few negative values and the described solution was regarded as adequate.

The indoor air quality will be analyzed in terms of CO_2 level, as this is normally used as the main indicator of air quality. As initiated in Chapter 2.1; current standards recommend the CO_2 concentration to not exceed 1000 *ppm*. Accordingly, this is the limit used when evaluating given results.

Regarding energy use, the zone heating will be analyzed, which represents the energy supplied to the zone through the waterbased radiator heating system. The energy use for heating is the main parameter for comparing the four different window opening strategies to be simulated. Although indoor environmental parameters will also be presented. TEK 17 includes energy efficiency requirements. The total energy use should not exceed $115kWh/m^2$ for an office building (Direktoratet for byggkvalitet 2017). Note that the energy use analysis in this thesis focuses on heating as apposed to the given requirement that includes the total energy consumption.

5.2. FIELD WORK AT ZEB TEST CELL LABORATORY

The following subchapter aims to present results specifically from the field work. That includes both measurements and questionnaires. The intention is to easily compare differences between the two test cells in regards to occupant feedback and collected data. The results are gathered from the experiment completed the 30th of April 2018. At that day participant 1 occupied test cell B, and participant 2 test cell A.

5.2.1. USER CONTROLLABILITY AND THERMAL SATISFACTION

Figure 5.2 show thermal sensation votes throughout the working day at the test cell. The graph is a result of responses to the questionnaires gathered every half an hour. The results are presented with a scatter plot as nothing can be said for the time period in between the questionnaires where feedback is not gathered. The thermal sensation votes are given in correlation to the time where the current questionnaire was completed. For convenience, the seven-point thermal sensation scale is rendered below.

Seven-point thermal sensation scale:

- +3 - Hot
- +2 - Warm
- +1 - Slightly warm
- 0 - Neutral
- 1 - Slightly cool
- 2 - Cool
- 3 - Cold

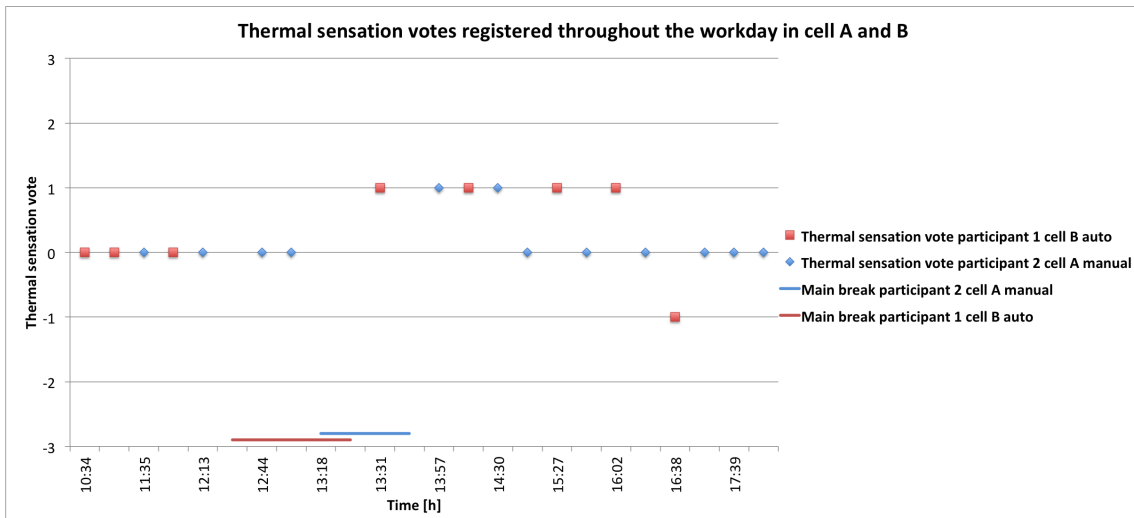

Figure 5.2.: Thermal sensation during the day as rated by both occupants.
Data gathered from 30.04.18.

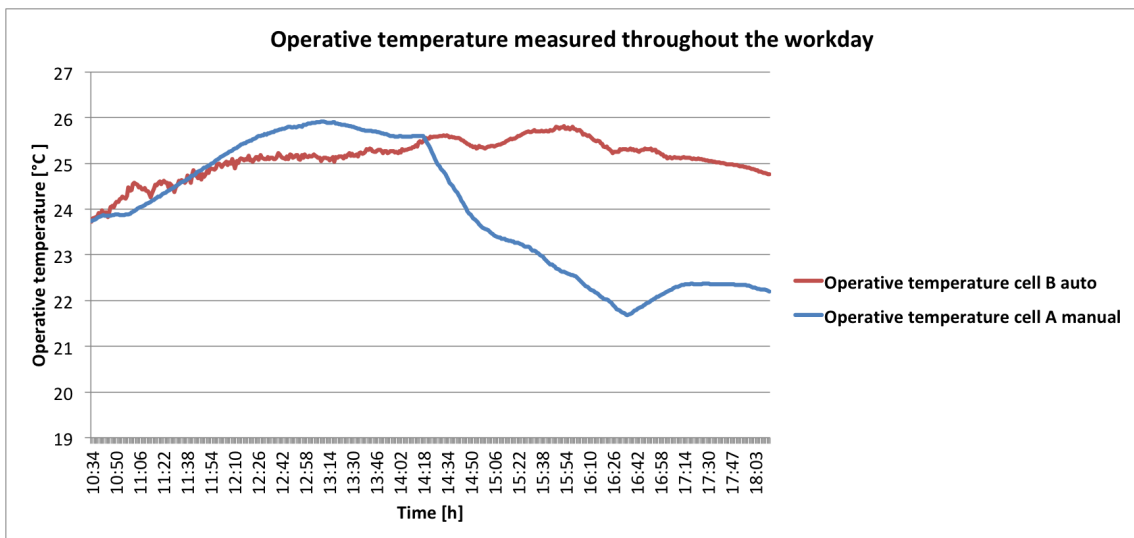

Figure 5.3.: Operative temperature at the time where questionnaires were completed.
Data gathered from 30.04.18.

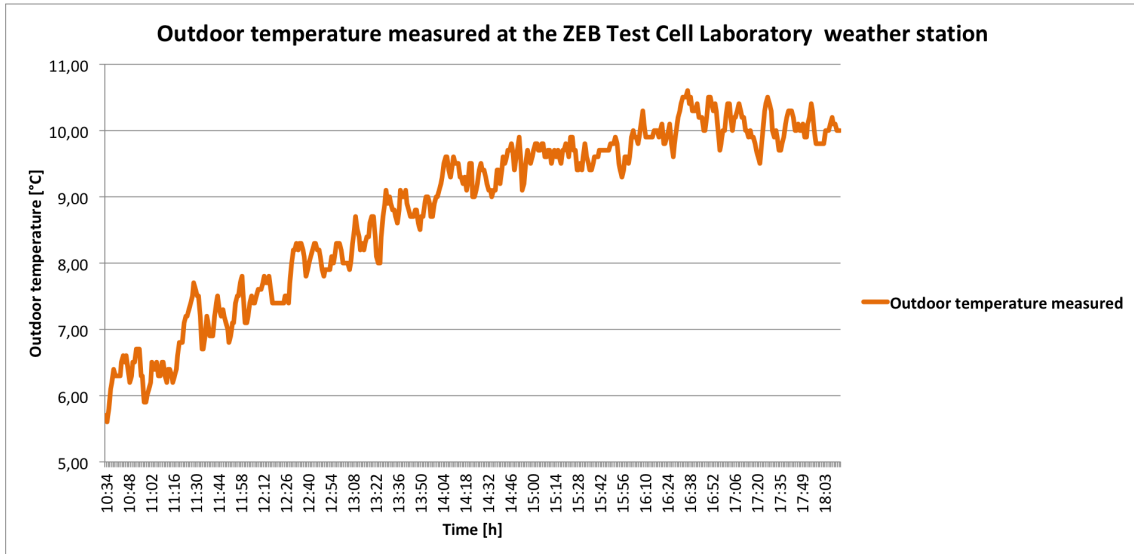

Figure 5.4.: Outdoor temperature at the time where questionnaires were completed. Data gathered from 30.04.18.

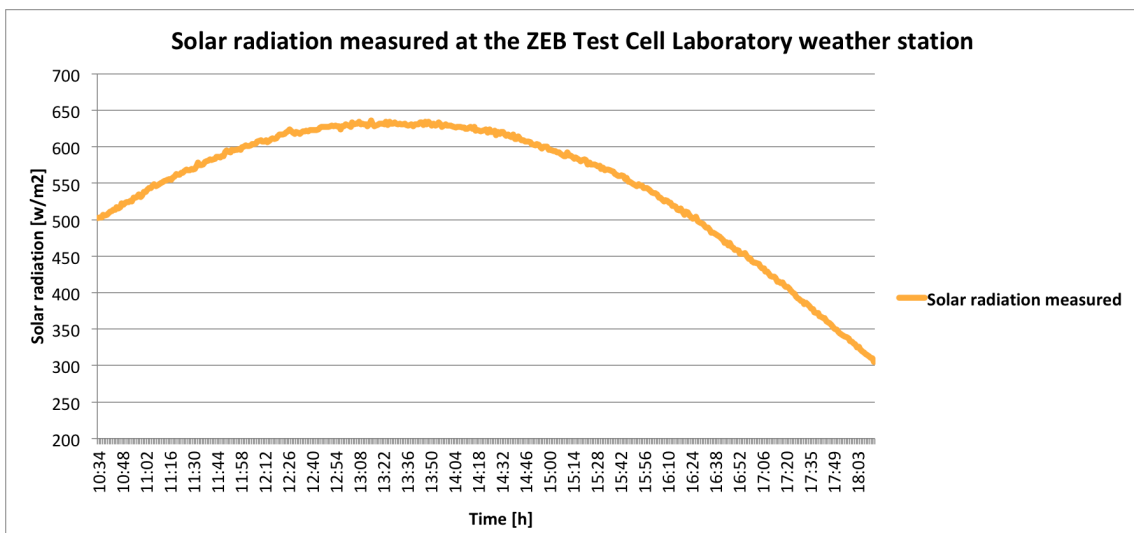

Figure 5.5.: Measured solar radiation at the time where questionnaires were completed. Data gathered from 30.04.18.

As can be seen in Figure 5.2 participant 1 and 2 did not arrive at the same time. Participant 1 in cell B started the work day an hour earlier than participant 2 in cell A. Consequently, the questionnaires has not been filled out at the exact same time and accordingly not under exact same conditions. For most parts of the day the thermal sensation votes were 0 which correspond to neutral. The variety of votes were greater for participant 1 in the automatic operated cell. Four votes has been given the number 1 and equals slightly warm on the seven-point thermal sensation scale. At one time, late in the day, the vote was -1 corresponding to slightly cool. In correlation, participant 2 in the manual cell has only voted the conditions to be 1, that is slightly warm, two times during the day. Otherwise the votes have been fixed at 0 and a neutral thermal sensation. The measured operative temperature has been included in Figure 5.3 for both test cells and can be analyzed in correlation to thermal sensation votes. The operative temperature was lower in the automatic cell until the point where participant 2 in the manual cell returned from lunch and turned off the radiator. Participant 1 in the automatic cell rated the thermal environment as 1 at a lower temperature than measured in the manual cell where the participant perceived the thermal environment as neutral. This correspond to findings from relevant literature. Occupants of automatically operated zones becomes well adopted to a more narrow range of temperatures. Participant 1 in the automatic cell gave a vote of -1 and slightly cool at 16:38. At the given time there was a slight drop in operative temperature from the last questionnaire at 25.7°C and down to 25.3°C. For comparison, the operative temperature measured at the current time in cell A was 21.7°C and participant 2 in this cell rated the thermal environment as neutral.

The measured outdoor temperature and solar radiation has been included in Figure 5.4 and Figure 5.5 respectively. Comparing outdoor conditions to the thermal sensation votes can provide a more thorough understanding as to why votes deviates from a state of neutrality. At 13:31 participant 1 in the automatic cell registered a vote of 1 as apposed to a vote of 0 and neutral the previous questionnaire. At this specific time the measured outdoor temperature was 9°C and solar radiation 632W/m². For comparison, participant 2 in the manual cell voted thermal sensation as 1 at 13:57 with the following outdoor conditions; an outdoor temperature of 8.7°C and solar radiation of 627W/m². Participant 2 had a later lunch and both the outdoor temperature and solar radiation had slightly decreased at time of return compared to conditions for participant 1. Approximately an hour later at 15:03 participant 2 perceived the indoor environment as neutral yet again. At that time the outdoor temperature was 9.8°C and solar radiation 594W/m². Participant 1 in the automatic cell went from rating the thermal environment as slightly warm to slightly cool. This was registered at 16:38 with an outdoor temperature and solar radiation of 10.4° and 481W/m² respectively. The outdoor temperature increased even though thermal sensation votes were improved from slightly warm to neutral and slightly cool. The solar radiation however decreased and could be one factor as to why the participants no longer perceived the indoor environment as too warm. Internal heat gains due to solar radiation can be large especially if external shading is not fully drawn. The current day this was the case for both test cells.

The presented results can be seen in regards to the difference in availability of controls. The occupant in the user operated cell showed more consistent thermal sensation and with the majority of votes at neutral. This finding correspond to results from relevant literature presented in Chapter 2. As stated in the work of Raja et al. user control plays a significant role when it comes to bettering comfort (Raja et al. 2001). Accordingly, Huizenga et al. emphasized that user control should be provided to occupants in order to improve comfort

more individually (Huizenga et al. 2006). An example that shows discomfort due to lack of user control follows. Participant 1 in the computer operated cell B gave feedback through the questionnaire revealing that the automatic window was open for longer than preferred. The participant expressed a desire to close the window sooner.

The results on thermal sensation should be viewed in correlation to the relevant research question. That is, do the participants of the case study rate thermal sensation differently when the zone is automatically optimized providing no user controllability, or when occupants have the possibility to affect the control strategies? As shown, the votes were more consistent and optimal for the occupant in the manually operated cell with a large amount of registered thermal sensation votes at neutral. A difference has been revealed and could be due to operating strategies. However, these results can not be discussed without yet again stressing the limitations due to the low number of participants. In order to see a trend of varying thermal sensation votes due to availability of controls, more than one set of occupants should participate in the study. As a result, the difference in perceived comfort could be due to other factors than those given focus here.

The red and blue line shows at what time during the day participant 1 and 2 had their main break respectively. Participant 1 had a longer break than participant 2. For both occupants thermal sensation votes were rated as slightly warm directly after having lunch. That is a change from before the break where both occupants rated thermal sensation as neutral. This could possibly be explained with results on food intake as presented in Fanger's PhD thesis. After a meal the preferred operative temperature was suggested to be reduced up to 1°C for a couple of hours depending on nutrients and protein in the food (P. O. Fanger 1970). Another explanation could be that occupants have increased their activity level because of walking back and forth to the test cell and possibly also their clothing level due to putting a coat on before leaving for lunch. Accordingly, the test cell conditions feel too warm when reentering. For participant 2 in test cell A the thermal sensation vote went back to 0, a state of thermal neutrality, in a shorter amount of time. A potential reason for this is correlated to the users feasibility to control indoor environmental conditions. Straight after returning to the test cell the participant turned the radiator off and a short while after opened the window as a side hung casement in order to lower the indoor temperature. As a result the comfort conditions improved more quickly. Although temperatures might not be any higher, it at this time felt too warm because behavioural factors had changed. The automatic system in cell B does not pick up on such factors of influence and the fixed strategies are pursued. Providing users the feasibility to control indoor environmental parameters ensures that comfort can be restored more quickly, and factors such as activity level, food intake etc. can be taken into consideration by the occupant himself. Note that a consequence of increased user controllability might be higher energy use or only a limited reduction. Everyone might not correspond to the though occupant of the adaptive approach, where a wider range of temperatures are preferred and energy use is minimized.

Viewing relevant literature has shown that many parameters can affect the perception of thermal comfort. Examples include indoor and outdoor conditions, gender, mood, health and state of mind. Deviation in results can be discussed in relation to personal and behavioral factors. Questions in part A of the questionnaire reveal such information. Firstly, the two participants are of different gender. This could be one important factor that lead to variations in the results. Both participants have rated their general mood and health as good. Although, one difference is that participant 1 felt a bit nauseous at the beginning of the day. Other factors worth mentioning is variations in clothing level, work tasks and transportation method to the test cell facility. Specifically, participant 1 was

doing writing that day and participant 2 working on his master's thesis further indicating a different stress level. Furthermore, occupant 1 took the bus to the test cell whilst occupant 2 walked. A final example is availability of user controls that has been shown to be of influence through both this experiment and relevant literature. All these factors and others not mentioned can affect comfort preferences. In view of this complexity, it might become difficult for occupants to express how they feel about the indoor environment or differentiate what factors might have lead to discomfort. Subconsciousness is a key factor when analyzing comfort preferences. For example if stressed one might perceive the temperature as too high even though it has not changed.

Lastly, the thermal sensation votes can be viewed in accordance with requirements from standard NS-EN 15251 on discomfort as presented in Chapter 2.3.1 and Table 2.3. Discomfort is acceptable if only for a short period of time. NS-EN 15251 recommends that deviation should only occur 3% of the time if a room constitute 95% or more of the hours of occupancy (Norsk Standard, NS-EN 15251 2014). That is the case for the test cell experiment and deviations should not occur more than 43 minutes daily. The thermal sensation votes ranged between -1 and 1, namely slightly cool to neutral and slightly warm. This is regarded acceptable and not directly discomfort. Although if compared to the recommendations slight discomfort occurred for a time period of half an hour for participant 2 in the manual cell. That is within the requirement of 43 minutes. For participant 1 however in the automatic operated cell, thermal sensation ranging from neutral took place for approximately three hours.

Question 1 from part C of the questionnaire is rendered below in Figure 5.6. This reveals the participants' comfort level at the end of the relevant day. Note that the entire questionnaire is presented in Appendix C. As seen in Figure 5.6, both participants rated their overall comfort level of the current day as clearly acceptable. That is despite differences in thermal sensation votes as shown in Figure 5.2. Slight discomfort during the workday is clearly accepted as thermal sensation only ranged between the narrow votes of -1 and 1, namely slightly cool to slightly warm. An overall perception of clearly acceptable is potentially due to the fact that most votes were rated as neutral. These results indicate the same trend as discussed through the literature review. Observations reveal that occupants accept slight discomfort and a greater variation of temperatures than suggested in standards based on laboratory tests. This corresponds to the adaptive approach.

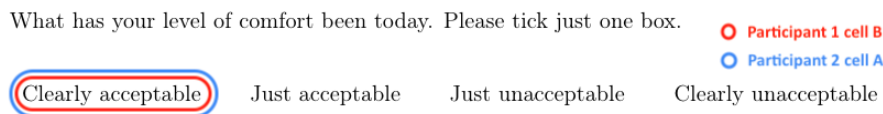

Figure 5.6.: Thermal comfort level as rated at the end of the current workday.
Data gathered from 30.04.18.

Through the questionnaire the occupants were able to identify their perception of temperature during the day. These results are presented with the graph in Figure 5.7. In order to present the results in an easy matter the acceptability votes of temperature are correlated to numbers ranging from 1 to 4 as shown below. The number 4 is correlated to a vote of clearly acceptable, the highest rating. The aim is to show the range of temperatures the participants has rated as acceptable and what temperatures are unacceptable. Results are presented with a scatter plot containing dots at the time the current questionnaire was completed and the corresponding vote.

Temperature acceptability votes:

- 1 - Clearly unacceptable
- 2 - Just unacceptable
- 3 - Just acceptable
- 4 - Clearly acceptable

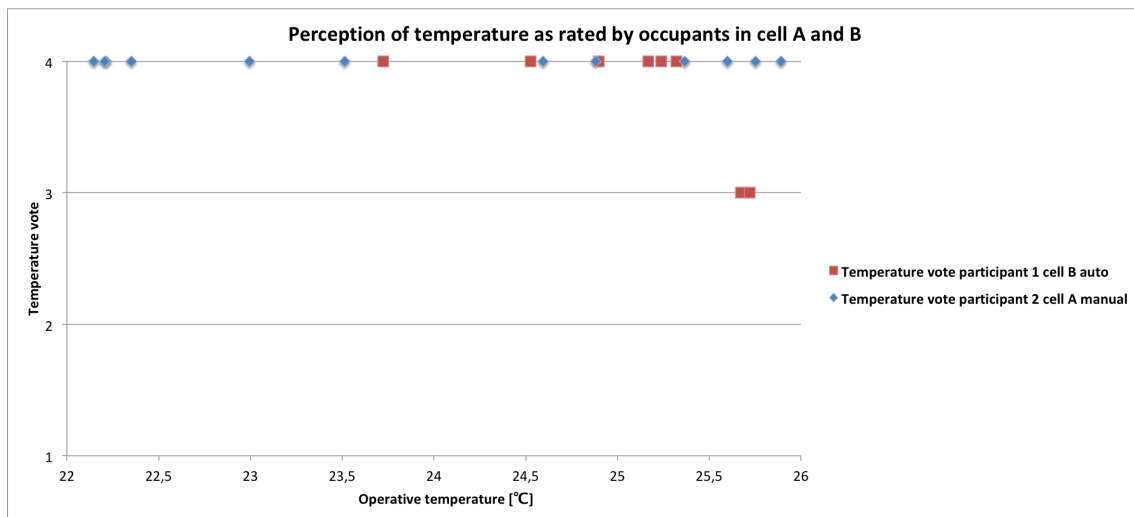

Figure 5.7.: Perception of temperature. Data gathered from 30.04.18.

The temperature votes will be analyzed in correlation to Figure 5.1 in Chapter 5.1 on planned evaluation of results. In this graph the optimal operative temperature can be determined based on activity- and clothing level. For participant 1 that implies $1.2met$ and $0.54clo$, and results in an optimal operative temperature of approximately $24.3^{\circ}C$. Participant 2 had a lower clothing level at $0.38clo$, but the same activity level of $1.2met$ according to the sedentary work at an office desk. This implies that a higher operative temperature is regarded as optimal for participant 2, approximately $25.5^{\circ}C$. The research question relevant to perception of temperature follows. To what extent is the occupants' acceptable indoor temperature affected by the user feasibility to control the indoor environment? Participant 2 in the manual cell perceived the temperature as clearly acceptable throughout the entire day. That included temperatures ranging from $22.1^{\circ}C$ to $25.9^{\circ}C$. This corresponds to thermal sensation votes presented in Figure 5.2 that were rather stable at neutral. It further corresponds to the availability of controls, providing a possibility to restore thermal comfort within a short amount of time.

All except two temperatures were rated clearly acceptable by the occupant in the automatic cell. The lowest measured temperature was $23.7^{\circ}C$. The registered votes were stable at clearly acceptable up to a temperature of $25.4^{\circ}C$. As the temperature increased slightly to $25.6^{\circ}C$ and $25.7^{\circ}C$ the participant perceived the temperature as just acceptable. The occupant in the manual cell rated an even higher temperature of $25.9^{\circ}C$ as clearly acceptable. This results in a difference in perceived maximal temperature of $0.3^{\circ}C$ between the two test cells. The difference could for example be due to the lack of controls available in the automatic cell or differences in clothing level. The optimal operative temperature was found to be $1.2^{\circ}C$ higher for participant 2 in the manual cell due to a lower clothing level.

If analyzing temperature votes in correlation to thermal sensation in Figure 5.2, it becomes clear that thermal sensation was voted slightly warm and slightly cool although the temperature was rated clearly acceptable. Note that thermal sensation is affected by more parameters than solely temperature. Participant 1 gave temperatures of 25.1°C and 25.2°C a thermal sensation vote of 1 and slightly warm, but temperature acceptability a vote of 4 and clearly acceptable. For the two temperatures rated 3 and just unacceptable, namely 25.6°C and 25.7°C, the thermal sensation votes were still 1 and slightly warm. One might expect a thermal sensation vote of 2 and warm as the temperature was rated downwards to just unacceptable. The deviations in both temperature- and thermal sensation votes were minimal. A slight variation in accepted temperatures was found between the two test cells and again could be due to availability of controls. As the participant in the manual cell perceived the thermal environment as slightly warm he reacted actively by further opening the window and turning down the radiator thermostat restoring thermal comfort. The whole range of measured temperatures are within category II in standard NS-EN 15251 as listed in Table 5.1. That is 20°C to 26°C and normal level of expectation. The given category is intended to apply for new buildings or buildings to be renovated.

The variation in accepted temperatures can be further discussed with the concept of thermal alliesthesia. This model was presented in Chapter 2.5 in correlation to the literature review. The perception of a stimulus depends on its potential to restore a neutral state of the body with minimal regulatory strain, as described in the work of Parkinson et al (Parkinson et al. 2012). This implies that how the participants experienced the current temperature depended on the initial state of the body. The exact same stimulus might be perceived as positive at one time and negative at another. This could to some extent explain why the participant in the automatic cell voted thermal sensation and temperature to deviate more from neutral and clearly acceptable. The fixed strategies pursued in the automatic cell might not be as preferred at the given time due to the initial state of the body, although within requirements given in relevant standards. If in a state of hypothermia, low initial body temperature, a low stimulus temperature is rated as very unpleasant. Opposite, when hyperthermia is the initial state the same stimulus is regarded as pleasant. Participant 2 reported that she would have liked to close the automatic window. At that time an operative temperature of 24.5°C was registered. This is higher than the suggested optimal operative temperature at 24.3°C, but probably due to having experienced temperatures reaching up to 26°C and the current draft from windows this was described as unpleasant. Alliesthesia can help explain the fact that occupants accept a more dynamic indoor environment which correlates to the manual cell. The initial state of the body is suggested to be an important factor according to the approach of alliesthesia. User control provide the occupant with the possibility to more actively optimize conditions directly based on individual state and preference.

Table 5.2 show the frequency of utilization for a given user control available in test cell A. Similarly, Table 5.3 show the number of times the participant would have liked to have a specific control available to operate in cell B in order to maximize comfort in own matter. The idea is to easily see what control is most frequently used by occupants if discomfort should occur. These results are obtained from questionnaires gathered every 30 minute where participants described what changes had been made to the work environment and why. This information was also registered in LabVIEW as sensors were connected to the different controls implemented further related to a true or false signal if operated and not accordingly.

Table 5.2.: Number of registered actions of user behaviour in cell A as a result of responses to the questionnaires. Data gathered from 30.04.18.

Participant	Window	Light	Radiator thermostat	External shading screen
2				

Table 5.3.: Number of registered actions missed by the occupant in cell B as a result of responses to the questionnaires. Data gathered from 30.04.18.

Participant	Window	Light	Radiator thermostat	External shading screen
1				

Table 5.2 shows that window operation was the control most frequently used to optimize comfort in test cell A. The radiator thermostat and external shading screen was only operated once during the workday. The lights were not controlled at all implying that they were turned off the entire day. Opening of windows and simultaneously turning off the radiator seem to be the first action that comes to mind when feeling too warm. As stated through relevant literature included in Chapter 2, air movement is one of the most efficient measures for improving thermal comfort (Fountain and Arens 1993). Results from a study presented by Raja et al. showed that window operation was applied to a great extent among occupants (Raja et al. 2001). Windows were open in 62% of the responses, whilst blinds or curtains drawn 24% (Raja et al. 2001). The results gathered for this thesis is not directly comparable due to a difference in the amount of participants. Additionally, the use of controls is a complex matter, as the use of one control might change with the use of another. However, the same tendency has been shown which further increases reliability of the results.

Not once did the participants reply back through the questionnaires that changing the level of clothing insulation was an action made to better comfort conditions. Although changing level of clothing is regarded as an effective personal measure improving thermal comfort. Similar results have been found in relevant literature as presented in Chapter 2. In the work of Brager and de Dear findings from a relevant study showed that only 12% chose to increase or reduce clothing level (De Dear et al. 1998). Interestingly, participants chose more regularly to take a break or make a hot or cold drink (De Dear et al. 1998), which only improve comfort for a limited time period. Such personal behavioural mechanisms has not been given attention in this thesis, but is an interesting finding in correlation to how people react to discomfort.

It is also of interest to emphasize why a certain control was applied. Through the questionnaire respondents described in more detail why a certain change had been made to their working conditions. This information has been gathered in the list below. The most

frequent reason for utilizing a given control was due to being warm. The current day the experiment was completed the sensors measured indoor air temperatures above 25°C almost throughout the entire workday. As a consequence the automatic controlled window was kept open, and the participant in the manually operated cell opened the window accordingly. As noted, at one time during the day participant 1 in cell B would have liked to close the automatic operated window. This can be seen in Table 5.3. The registered reason for wanting to be able to do so was due to draft.

Frequently cited reasons for utilizing or demanding a given control:

Windows	Warm	Cold
Radiator thermostat	Warm	
External shading screen	Warm	

Huizenga et al. emphasize the importance of providing user control to more occupants. A result is higher level of satisfaction, as stated by Huizenga et al. (Huizenga et al. 2006). Generally, manual operation ensures that the occupants have more control of the thermal conditions and can optimize parameters in own matter. However, such solutions entail larger uncertainties in regards to estimating energy use in the early design phase. In the automatic cell the indoor environment can to some extent be perceived as more imposed. Nevertheless, current trends are that systems should be computer operated leaving the occupants with the freedom of not focusing on control strategies being optimized in terms of energy use. However, it might not always optimize comfort to pursue a fixed operating strategy.

The indoor environment has been analyzed in regards to the quality of indoor air, further characterized by the level of CO_2 . Figure 5.8 presents the measured CO_2 in the two test cells throughout the workday. The event of window opening has been included to show the increase in quality of indoor air by utilizing this control. At the current day only the top window was operated in the automatic cell B, whilst only the bottom window was opened by participant 2 in cell A.

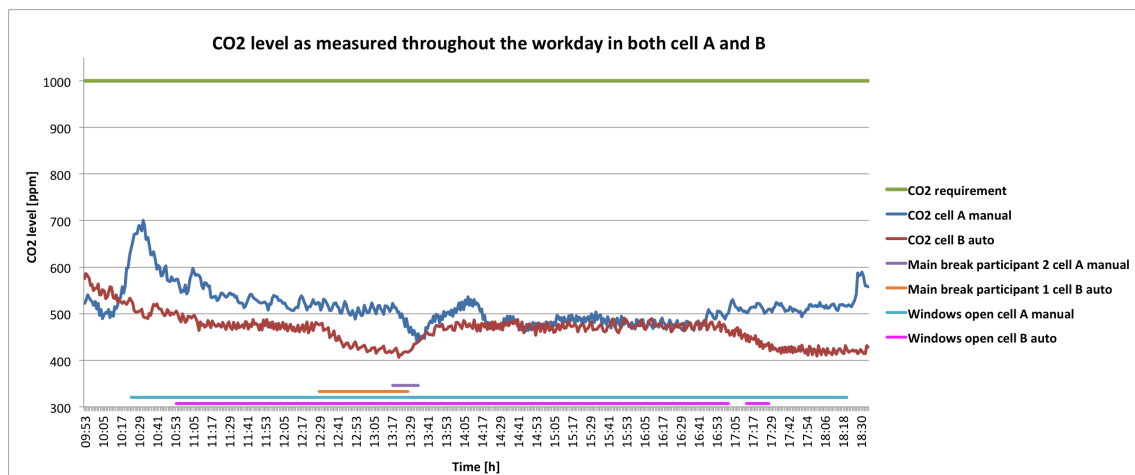

Figure 5.8.: The CO_2 level in correlation to the event of window opening. Data gathered from 30.04.18.

Note that participant 1 arrived at the test cell an hour earlier than participant 2 and worked until 16:50. Participant 2 did not leave the test cell until 18:30. This can be seen in the graphs as presented in Figure 5.8. The level of CO_2 was higher throughout the workday in the manually operated cell A. However, for both test cells the CO_2 concentration was well within the requirement of 1000ppm as included with the green line in the graph. Both participants rated the air quality as clearly acceptable throughout the whole day. For both work spaces the CO_2 concentration was highest at arrival. The CO_2 level decreased for both cells as the windows were opened, and accordingly a stagnation or increase was found as the windows closed. There was a further decrease at 12:29 in cell B and 13:18 in cell A due to the occupants leaving the room to have lunch. The CO_2 level increased consequently as the participants returned.

The automatically operated top window in cell B was opened if the mean air temperature as measured by the three Pt100 sensors were higher than 25°C. At the specific day this was the case approximately the whole time during occupancy. Participant 2 in the manually operated cell chose to open the bottom window at the very beginning of the workday. At this time the window was opened as a bottom hung window tilted inwards. After returning from lunch participant 2 perceived the indoor temperature as too high and as a consequence turned off the radiator. However, it was still too warm than preferred according to the occupant and the bottom window was opened wider at 14:18. The bottom window provides two opening strategies and was now opened as a side hung casement. This affected the indoor air quality positively and can be seen in Figure 5.8 as the CO_2 level decreased at the current time. At 16:35 the window opening was reduced putting the position back to bottom hung and the CO_2 level increased slightly.

With the presented result it has been shown that the indoor environment in terms of air quality is acceptable and within requirements both if the cell is manually and automatically operated. The ventilation system ensured a constant air flow supplying fresh air to both zones. Consequently the CO_2 levels were low. In order to further increase quality of indoor air effort was needed by the occupant in the manually operated cell. For participant 1 in cell B, slot ventilation by window operation was provided automatically and no attention was needed. However, a drawback of such a solution is that the implemented control strategy might not correspond to the current preference of the occupant. This has been confirmed as the participant in the automatic cell would have liked to close the window at one point during the day.

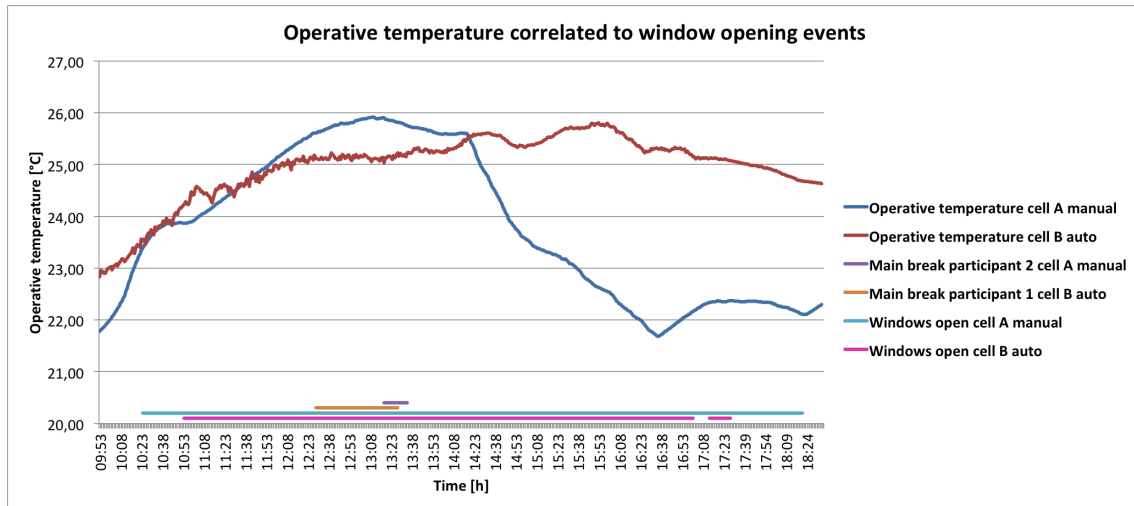

Figure 5.9.: Operative temperature in correlation to the event of window opening. Data gathered from 30.04.18.

Window opening events and the main break has also been correlated to operative temperature. This can be seen in Figure 5.9. The blue, purple and turquoise lines are corresponding to cell A and participant 2. The operative temperature stagnated as the window was opened at 10:24, but continued to increase short time after due to occupancy. The participant started to work in the test cell at 11:00. The operative temperature decreased slightly at 13:18 because of the main break. The great decrease at approximately 14:19 is assumed to be because the participant shut down the radiator thermostat and set a wider window opening. Events and measured temperature for cell B is shown with the red, orange and pink lines. The window opening of the automatic top window was limited. However, a slight increase and a followed decrease in operative temperature was registered as the window was shut before reopened at 17:01 and 17:13 respectively. The participant left at 16:48, thus the temperature continued to decrease even though the window was closed.

Based on relevant research it was reasonable to assume that the participant in the manual cell would not open the window before the automatic. That is based on the assumption that occupants in manually operated cells allow higher temperatures according to the adaptive approach. However, the presented results show opposite tendencies. The bottom window was opened earlier at an operative temperature of 23.4°C. The time difference though for the first opening event was minimal, 10:24 and 10:54 for the manual and automatic cell respectively. Again, specifies that the automatic window was opened if the average air temperature measured by the three sensors were higher than 25°C. Note that the air temperature at 10:24 in the manual cell was 23.3°C.

5.2.2. LIMITATIONS OF THE EXPERIMENT

A significant limitation of this experimental work is the low number of participants. Only two occupants lay the basis for the results in terms of the study on user controllability. Results should preferably be presented for more than one case day. However, due to the startup date being postponed for more than two months, the remaining time schedule did not allow for more data to be gathered and analyzed. Following, no general conclusions could be drawn as then a much larger database should be gathered. Similar studies presented in Chapter 2 on relevant literature have operated with up to several thousand participants increasing reliability of the study. As a result of the small number of participants, the results are of no statistical significance. Nor will it represent the general Norwegian population in terms of gender and age distribution. This can be seen in Figure 5.10 presenting a population pyramid for Norway. Generally, if there are no participants representing a given gender and age group then the results can not be used to conclude anything about that specific group. As become known through the literature review, comfort preferences seem to differ between age groups. This again shows the weakness of the results due to a low number of participants. Furthermore, the people attending the study are of a younger age. This is neither fully representative of the age distribution at a general office where often majority of employees are at an age of 40 to 50 years.

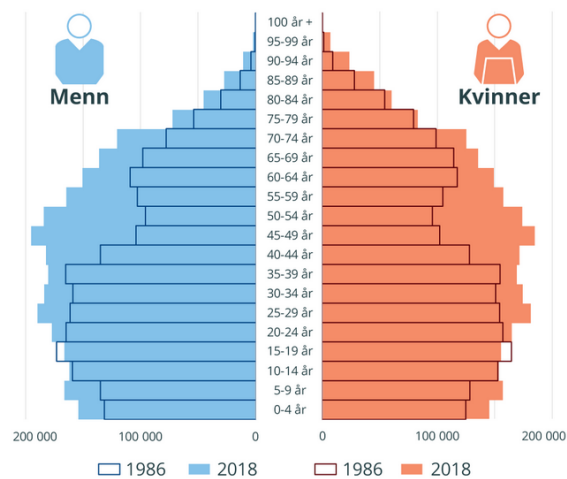

Figure 5.10.: Population pyramid showing the composition of the Norwegian population in terms of gender and age, Ref.: (StatisticsNorway 2018).

If studying the graph in Figure 5.10, the group of participants constitutes three of the age and gender groups. That is females (Norwegian: *Kvinner*) 30 to 34 years (Norwegian: *år*) shown with the red coloured block diagrams, and male (Norwegian: *Menn*) 25 to 29 and 35 to 39 given with the blue block diagrams. Although one subject in each group is not representative. Non of the participants for the week of study are originally from Norway. It would improve the study focusing on a colder climate if residents of Norway participated. One of the male participants has been in Norway for four years and is to some extent well adopted to the Nordic climate. Especially as he has moved here permanently, and his origin is Poland also regarded as a cold climate. The two remaining participants are from Indonesia and Italy and have only been in Norway for a shorter amount of time. The warm and humid climate in their home country might lead them to have different preferences

and expectations to the conditions in the test cell. Positively, the group of participants include both genders.

In order to further increase the reliability, then similar studies should be completed during different periods of the year. All ranges of temperatures and weather for the cold climate of Trondheim should preferably be covered. For the sake of analyzing a cold climate this experiment was to be conducted in a colder month. Again, due to a delay the study was postponed until May. This is the last of the spring months before summer. It would be of interest to see the effects of a Nordic climate at different seasons and specifically winter.

One occupant was present during working hours in each cell and for a short time period of only a couple of days. A longer period could be beneficial. The initial idea was that each person would stay for two work days in one cell then change over to the other cell for the two following days. For the next week a new couple of participants should have occupied the test cells. The pair of occupants should preferably always consist of one male and one female. The participants however signed up for varied days and this showed not to be possible. As a result the arrangement was more random. And yet again, due to a late start up date the experiment for this thesis only constitutes a week.

Not accounted for is that the test cell type, manual or automatic, the occupant entered first probably affected the users experience. Additionally, there were limited time for acclimatization between the different environments of the two cells. This implies that the expectations to the second test cell might have been different than the initial state. A first period in the automatic cell might have made the occupant used to fixed conditions and little variation in temperature. Opposite, a first period in the cell providing user control might have lead the occupant to feel as if the automatic cell is a more imposed environment. Another limitation is that two different participants were occupying cell A and B when gathering results from the study on user control. That is advantageous as data was collected on the same day and under the same weather conditions. However, the results might have come out different if the same participant had occupied both cell A and B the consecutive days. Comfort preferences can be different for the two participants and variations in results could be due to this factor and not only the difference in operating strategies. Although, then the weather conditions might have varied as results would have to be compared from two different days.

One uncertainty is correlated to the sensors which were placed visible in the occupied cells. In the case of the automatic controlled zone, the operating strategies might not have been as preferred by the participant. In such a case, a relevant scenario could be that some would manipulate the sensors to obtain a different outcome. For example by covering the luxmeter to get the room light back on if the controlled sensors measured enough daylight and turned the ceiling light off. In order to limit this uncertainty the participants have not been given any information about the sensors, what they measure and the control strategies.

Another source of error is correlated to the questionnaire. Firstly, it is of great importance that the author of the questions and the person filling out the survey understands the questions the same way. In this case, if the occupants does not have fundamental knowledge on thermal comfort this might affect how the questions were answered. Boredom is also critical when it comes to using questionnaires. As the occupant had to answer the same questionnaire for a couple of days and the main part several times during the same day, the questions became known. This implies that the time spent analyzing the situation might get less valuable and answers become not that thought through. The pop-up questions

every half an hour might have come at a time where the occupants were submerged in their work and felt as if they did not have time to answer or have not registered that a new questionnaire was due. The pop-up survey showed at what time the next questionnaire would appear. However, if the occupants did not notice the time then the period between two questionnaires could easily become more than 30 minutes and not be the same for the two participants in cell A and B. A possible solution to this problem could be to have a sound or an alarm go off in the software when the questionnaire was due. This would also allow the occupants to forget about the survey and not pay attention to the scheduled time for the next registration as this could affect their work concentration. Additionally, some questions were given with the possibility of writing a more detailed answer, as can be seen in Appendix C. This would give valuable feedback, but at the same time lead to a lack of information if the occupants failed to utilize this possibility. Another factor in regards to the validity of the questionnaire is the level of truth. Did the respondents report back what they have actually done and experienced of comfort? Often actions are made subconsciously. Such factors should be mentioned as a limitation, but is not within the scope of this thesis.

Furthermore, the laboratory used for the experiment might be a limiting factor itself. The test cell provides excellent conditions for detailed measurements. However, the feel of the space might affect completion of the questionnaire. The occupants were not in their familiar surroundings. As initiated in Chapter 2, interior, furnishing and wall color are factors suggested to affect thermal sensation (Oseland 1995). One can have an impression that it is colder due to the feel of the room. This could be the situation in a chamber cell like the ones utilized for this field work. This implies that the preferred neutral temperatures might have varied if the surroundings were different. Thermal sensation is a term affected by several factors. Another limitation to be mentioned is the addition to the $[clo]$ value due to the office chair, which has not been accounted for. An office chair has been suggested by Brager and de Dear to be an addition of $0.15clo$ to the initial clothing value (Brager and Dear 1998).

User controllability and thermal comfort could preferably also be analyzed with a number of occupants in the same zone. It is known through relevant literature that one thermal condition might not satisfy all. There will only be one thermostat and one window to operate, and each individual occupant is assumed to have different preferences. Additionally, several other factors influence the total perception of the thermal environment, not included here. However, utilizing the ZEB Test Cell Laboratory does imply that user's preferences for room control strategies can be compared as two identical test cells are provided with similar conditions and room configurations.

A final limitation to be mentioned is in regards to the measuring equipment. If more than one sensor was used to measure the same parameter, a mean value has been calculated and further used when presenting the results. Every sensor operates within a specific range and have an accuracy of a given percentage. Actual values might differ slightly from those measured. Especially when considering the calibration completed. The anemometers become direction sensitive at low air velocities which can result in unrealistic measurements. Negative values was set to zero when analyzing results from the calibration, assuming it was due to noise and a negligible error. Subsequently, another method could preferably have been to define a low air velocity instead of eliminating the given sensor measurement by setting the value to zero. At low air velocities as measured, draft is absent and setting a fixed constant where measurements are unrealistic could be done uncritically.

5.3. SIMULATIONS OF THE TEST CELL

The research carried out with IDA ICE contains two parts or areas of focus. Namely analysis of user controllability in terms of thermal sensation and user behaviour in correlation to window operation. A presentation of relevant results and discussion follows.

5.3.1. COMFORT RESULTS BASED ON REGISTERED USER BEHAVIOUR

The following results have been obtained by completing simulations for the two test cells covering the actual day of the experimental work. That is the 30th of April 2018. Furthermore, the time frame of the simulations were set to working hours for the participants which was different for the two test cells. Accordingly, the simulation time was set to 11:00:00 to 18:30:00 for test cell A and 09:53:00 to 16:48:00 for test cell B.

Figure 5.11 and Figure 5.14 show Fanger's comfort index PMV as predicted by calculations in IDA ICE for test cell A and B respectively. The PMV calculations in IDA ICE take into consideration temperature, radiation, moisture and draft as well as occupants' clothing level and level of activity. The calculated value should preferably lie close to zero representing a thermal sensation vote of neutral. The seven-point thermal sensation scale as presented in Chapter 2.3.1 is rendered below.

Seven-point thermal sensation scale:

+3	-	Hot
+2	-	Warm
+1	-	Slightly warm
0	-	Neutral
-1	-	Slightly cool
-2	-	Cool
-3	-	Cold

In regards to the calculation method of PMV and also the focus of the questionnaire, the temperature is of relevance when discussing the presented results. Accordingly, the operative temperature calculated in IDA ICE for cell A is included in Figure 5.12 and for B in Figure 5.15.

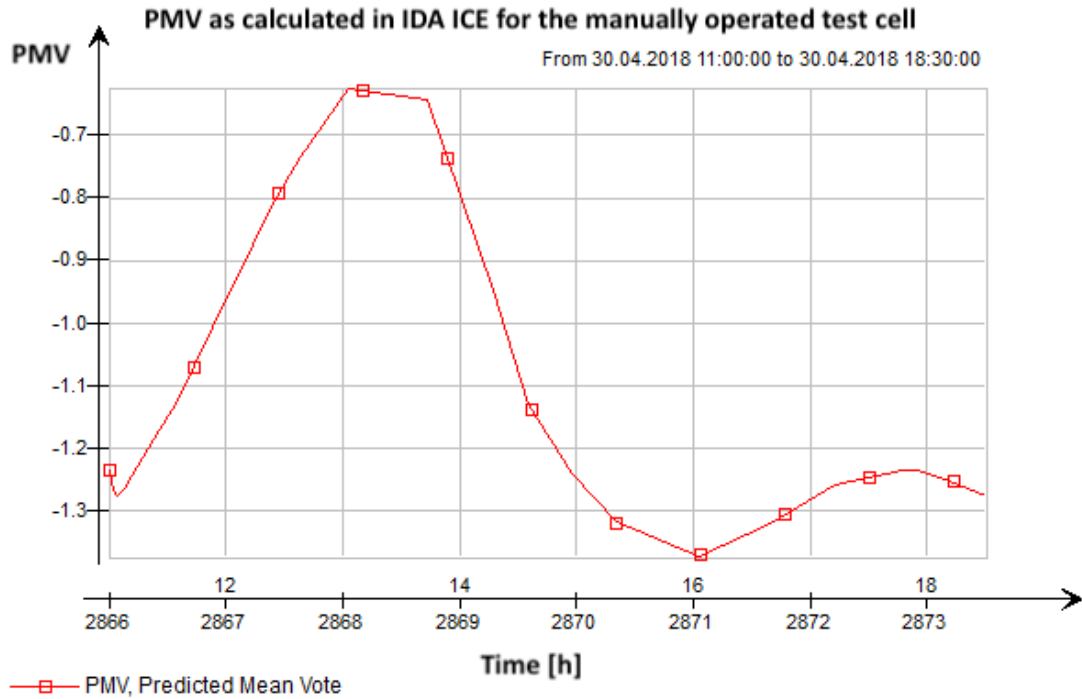

Figure 5.11.: Fanger’s comfort index for test cell A as calculated in IDA ICE. Data gathered from 30.04.18.

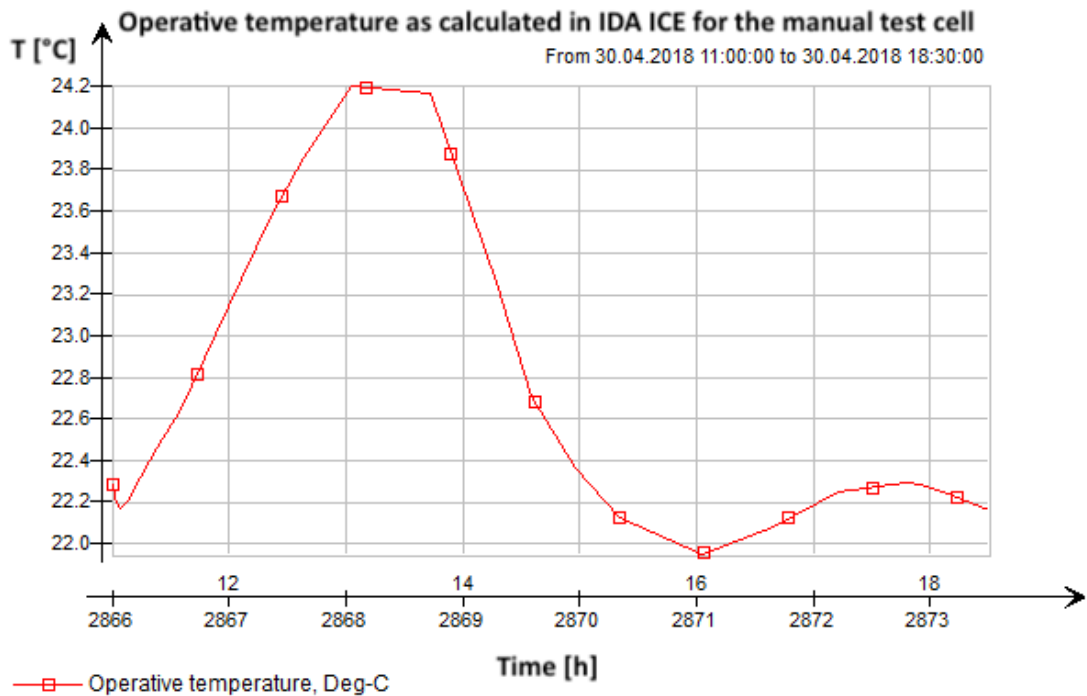

Figure 5.12.: Operative temperature during the day in cell A as calculated in IDA ICE. Data gathered from 30.04.18.

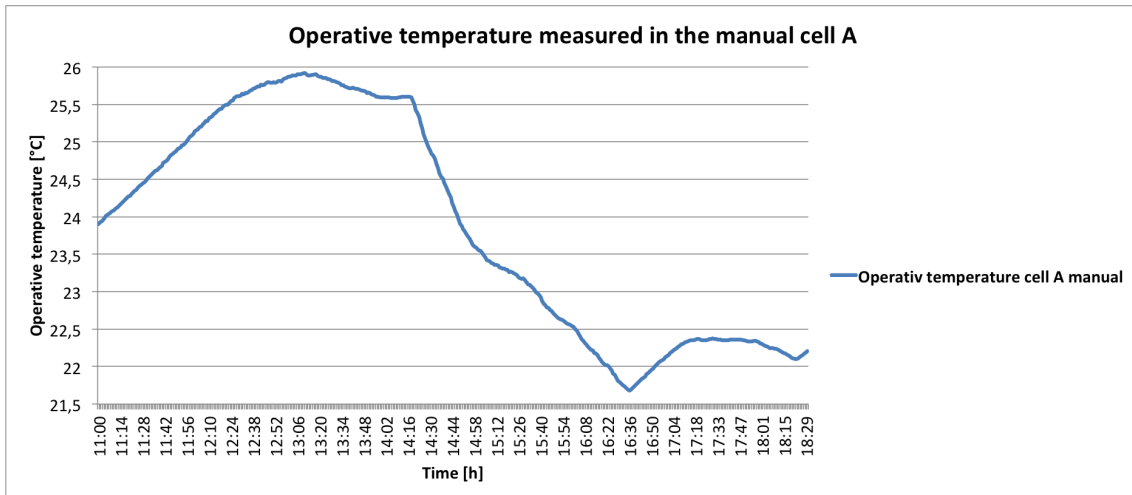

Figure 5.13.: Measured operative temperature during the day in cell A.
Data gathered from 30.04.18.

By analyzing the graphs for cell A in Figure 5.11 and Figure 5.12 it is clear that the value of PMV is depending on the temperature. Both curves follow the same pattern. As the temperature increased the PMV increased approaching a value of zero and a thermal sensation of neutral. The minimum and maximum calculated value of PMV for the manual cell was -1.332 and -0.6582 respectively. When correlated to the seven-point thermal sensation scale this implies beyond neutral at 0 to slightly cool at -1 and not quite reaching cool at -2. The temperature in correlation to the PMV that equals -0.6582 was calculated to be 24.11°C. It was assumed by standard calculations that the occupants prefer a higher indoor temperature. At a temperature of 22.06°C the PMV was -1.332 and a thermal sensation of slightly cool to cool was predicted. The PMV as calculated in IDA ICE was more detailed including numbers ranging also between integers, whereas the participants only had the opportunity to vote thermal sensation at fixed numbers from -3 to +3 namely cold to hot.

The results should be viewed in correlation to thermal sensation votes gathered from the questionnaires as presented in Figure 5.2. For participant 2 in cell A, shown with the blue scatter plots, most votes were rated neutral. At two times during the day the thermal sensation was perceived slightly warm. However, not once did the participant in test cell A rate the thermal environment as slightly cool or cool. Seemingly, the participant in the ZEB Test Cell Laboratory accepted a greater range of temperatures expected to cause discomfort by standard calculations in IDA ICE. This trend correspond to findings from the literature review where occupants were suggested to prefer a wider variation of temperatures. That is if the zone is manually operated making occupants more active participants of the indoor environment, which is the case for test cell A.

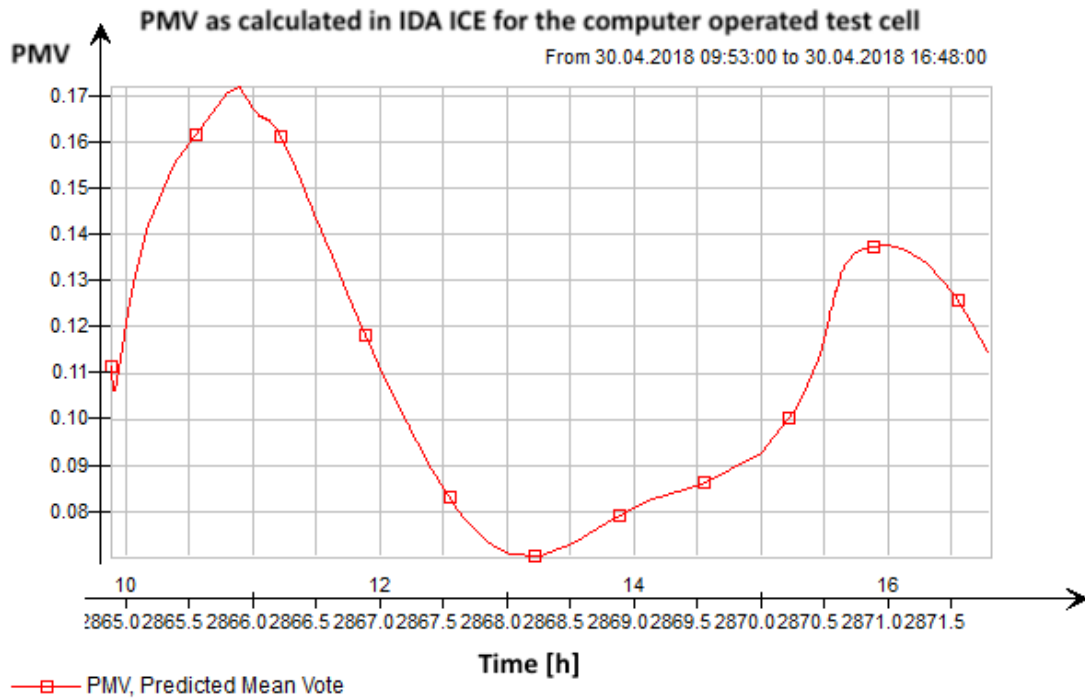

Figure 5.14.: Fanger’s comfort index for test cell B as calculated in IDA ICE. Data gathered from 30.04.18.

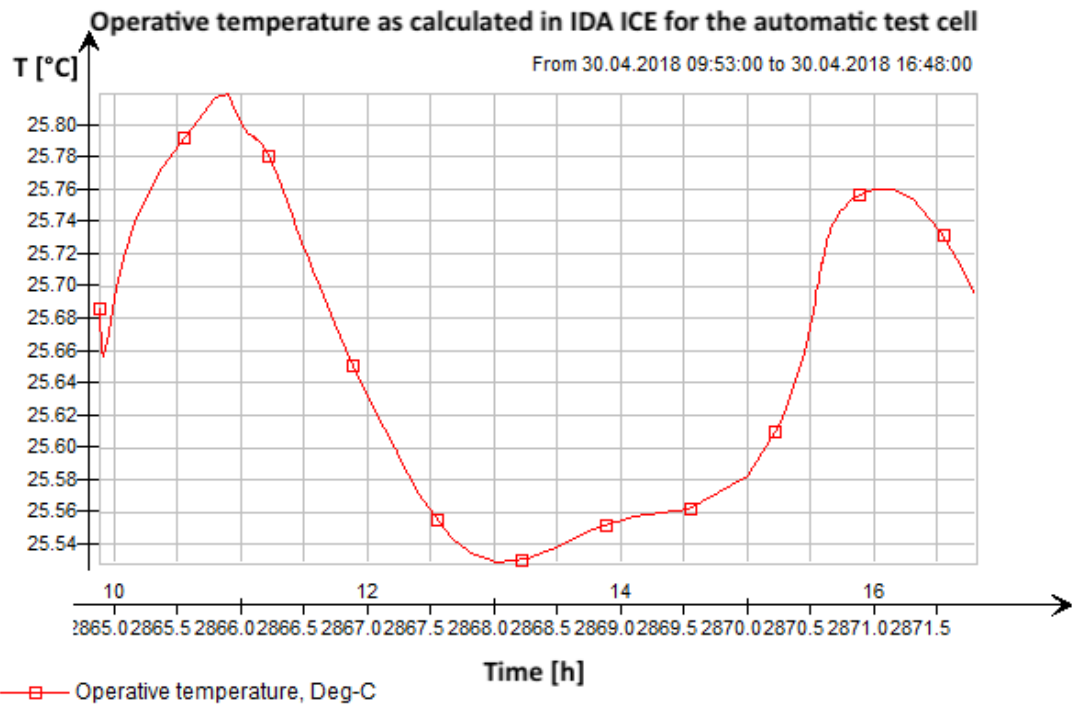

Figure 5.15.: Operative temperature during the day in cell B as calculated in IDA ICE. Data gathered from 30.04.18.

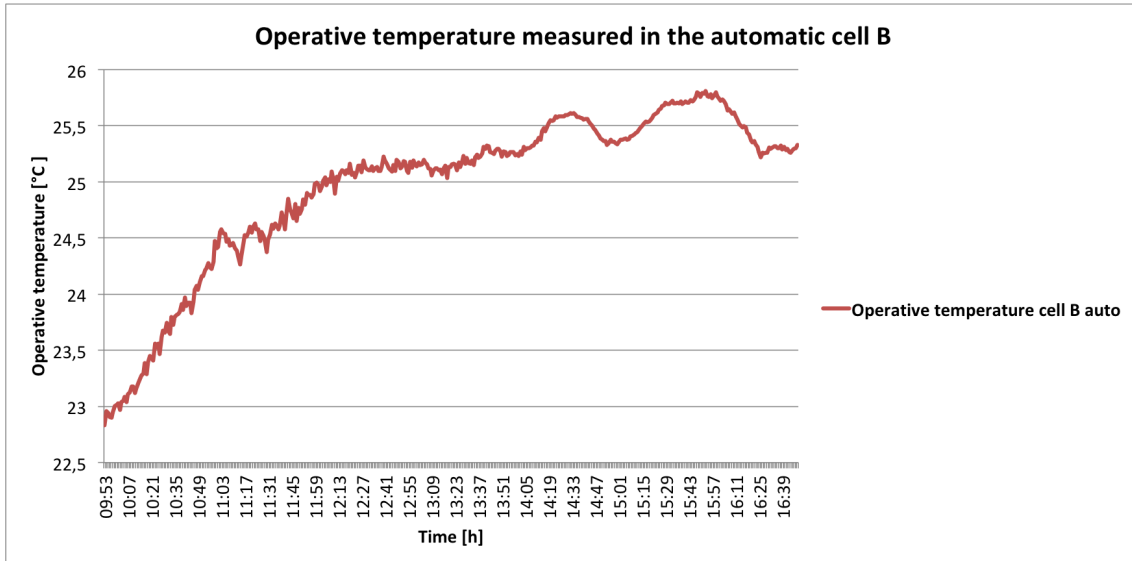

Figure 5.16.: Measured operative temperature during the day in cell B.
Data gathered from 30.04.18.

Again, by analyzing data for cell B in Figure 5.14 and Figure 5.15 the two graphs for PMV and temperature are cocurrent. Calculated PMV was positive at all times ranging between values of 0.07414 and 0.1564. The calculated PMV was more constant and only a tad above neutral reaching slightly warm. The operative temperature was consistent ranging between a minimum of 25.54°C and a maximum of 25.78°C respectively. This is similar to measured temperatures at the test cell where air temperatures throughout the current day were constant above 25°C. Accordingly, the automatic window was kept open during almost the entire workday. The predicted values of PMV were more equal to the observed trends for the automatic cell. Figure 5.2 shows perceived thermal sensation for participant 1 in cell B with the red scatter plot. Votes at the start of the workday were constant at neutral. Past 1 PM the calculated PMV became higher and towards a vote of slightly warm. That is the same trend as shown in Figure 5.2 presenting observed values. Although at the start of the day the calculated PMV was at its maximum, which is not corresponding to results from questionnaires. Again though, note that PMV calculated in IDA ICE has more detailed values with decimal numbers. This implies that the participant even though rated thermal sensation as 0 or neutral might be a tad warm because the next step with a vote of 1 is not quite corresponding either.

The aim of this specific simulation in IDA ICE was to try and answer the following research question. That is, do the participants of the case study represent a standard vote in correlation to the PMV model? For the computer operated cell the concurrence between calculated and observed PMV votes were most evident, ranging between neutral and slightly warm. That is as expected if results are compared to relevant literature as presented in Chapter 2. Predicted standard values correspond to observed values for computer operated zones. However, when the space is controlled by the user then standards fail to predict preferred temperatures and thermal sensation. This trend was shown when comparing calculated PMV and observed thermal sensation votes in correlation to the ASHRAE adaptive approach in Chapter 2.4.2. Figure 2.4 and Figure 2.5 presents field based and laboratory based comfort temperatures in correlation to the PMV model for mechanically and naturally ventilated buildings respectively. Accordingly, that is build-

ings the occupant do not have the possibility to control and buildings where user operation is available. The results led ASHRAE to include an adaptive approach in their standard 55.

The operative temperature measured in cell A and cell B is presented with the graph in Figure 5.13 and Figure 5.16 respectively. This way measured values can easily be compared to calculated temperatures from simulations in IDA ICE. Deviations could be due to how the radiator was implemented in the simulation model. Fixed setpoints were applied corresponding to indoor temperature. One other reason could be the noise registered on the anemometers causing negative values for the air velocity also after calibration. This noise was cancelled by setting measured values to zero and can be one reason why operative temperature at the beginning of the day not correspond to calculations in IDA ICE for the automatic cell. IDA ICE registered temperatures varying around 25°C. This correspond to measurements on air temperature. The automatic window was opened at 10:54 and air temperatures above 25°C in accordance with the fixed strategy applied.

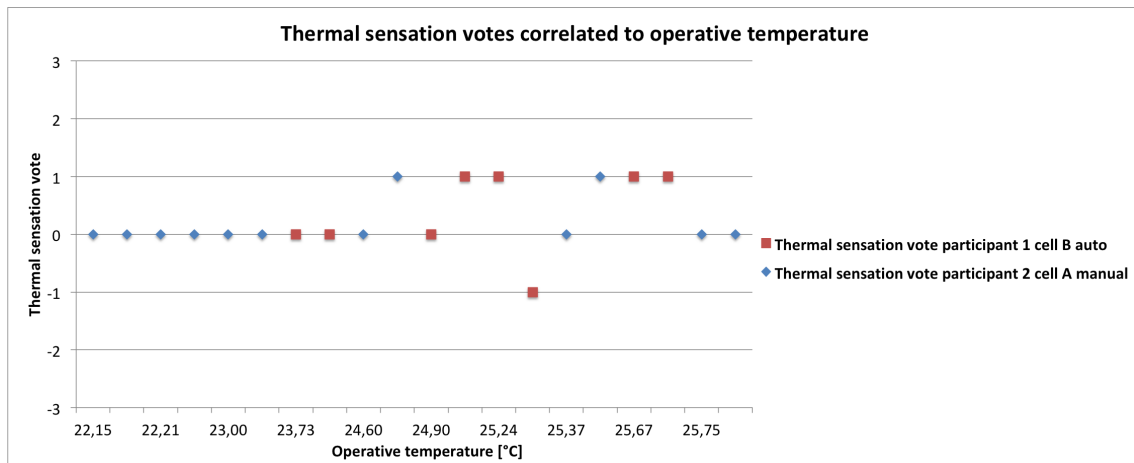

Figure 5.17.: Thermal sensation votes correlated to measured operative temperature. Data gathered from 30.04.18.

Registered thermal sensation votes has been correlated to temperature in Figure 5.17. This makes it easy to overview what temperatures the two participants have rated differently. At lower operative temperatures both participants perceived the thermal environment as neutral with a vote of 0. A greater variation was found as the operative temperature increased. The occupant in the manual cell was shown to allow higher temperatures. At an operative temperature above 25.5°C participant 1 in the automatic cell registered two votes of 1 and slightly warm whilst participant 2 in the manual cell voted 0 and a state of neutral.

The thermal sensation votes correlated to temperature in Figure 5.17 can be compared to determined PMV according to Appendix E in standard NS-EN ISO 7730. Note that values gathered from the standard apply for a relative humidity of 50%. Positively, the measurements on humidity registered from the weather station at the ZEB Test Cell Laboratory the current day, were close to the given prerequisite. At an activity level of 1.2 met , clothing level of 0.5 clo and low air velocities the PMV can be determined based on operative temperature. The relevant values follows. Operative temperatures of 22°C, 24°C and 26°C are suggested to result in a PMV of -0.79, -0.17 and 0.44 respectively (Norsk Standard, NS-EN ISO 7730 2006). That is slightly cool, slightly cool close to neutral and

slightly warm although close to neutral. A low temperature as 22° was only measured in the manual cell and the participant rated the thermal environment as neutral at the given temperature. Both participants perceived the thermal environment as neutral at an operative temperature of 24°C. The participants accepted both 22°C and 24°C and obtained a state of neutrality as opposed to the predicted condition of slightly cool. As the operative temperature increased towards 26°C the participant in the automatic cell were not longer neutral, but slightly warm. This correspond to the PMV determined by the NS-EN ISO 7730 standard. The occupant of the manual cell though still perceived the thermal environment as neutral. The predicted and observed values are compared with a slight deviation as the clothing level for the occupants were 0.54*clo* and 0.38*clo* for participant 1 and 2 respectively. The standard values obtained from NS-EN ISO 7730 apply to an occupant with a clothing level of 0.5*clo*.

Based on these key findings it has been shown that the participant in the automatic operated cell represents a standard vote to a greater extent than the participant in the user operated cell. The participant in cell A did not rate the thermal environment slightly cool as predicted by standard votes calculated in IDA ICE. Actually, the participant in the manually operated zone perceived the thermal environment as neutral or slightly warm. Generally, as shown through relevant literature, standard calculations does not correspond as well to observed values for user operated spaces as for computer operated zones. Temperature preferences are not narrow and fixed as assumed in standards. Note that PMV consider more factors than temperature as stated in the introduction of this subchapter. Regardless it has been the main focus here when analyzing the results. It is reasonable to assume that occupants initially thinks of their perception of temperature when thermal sensation is requested in correlation to the seven-point scale. Although other indoor environmental parameters subconsciously affects the perception.

5.3.2. USER OPERATED WINDOW CONTROL

The following results have been obtained by completing a simulation in IDA ICE for the time period 30.04.18 to 04.05.18, 00:00:00 to 24:00:00 each day. These are the days where participants were occupying the manual test cell during the week of experiments. An overview of the arrangement of participants for this study can be found in Chapter 3.4.6 and Table 3.4. Note that the results on energy use only applies to a single cell office placed at the south facade of a building, as this is the case for the test cell models.

Table 5.4.: Results showing user behaviour effects on heating consumption and IEQ.
Data gathered from 30.04.18-04.05.18.

User strategy	Zone heating [kWh]	CO ₂ [ppm]	Max T _{op} [°C]	Min T _{op} [°C]
1	6.174	500.7	23.51	21.4
2	Radiator off	676.1	30.71	24.16
3	3.007	675.4	28.32	21.38
4	1.031	673.9	27.67	21.53

Table 5.4 present results from the simulations completed on the four different window opening strategies. The results show user behaviour effects on heating consumption and IEQ. The main aim of these simulations were to analyze energy use for heating. The research question to be answered is; to what extent is the energy consumption for heating affected by user behaviour? As seen from Table 5.4, the energy consumption varied greatly. That is from the radiator being turned fully off to delivering 6.174kWh. Such variations only being due to user behaviour might result in actual energy consumption being much larger than that calculated during the design process. The interaction between occupants and the indoor environment is complex. The results can be discussed with an example given in the literature review in Chapter 2. A study as presented by Andersen et al. revealed a variation in energy consumption between identical houses to be a value of 600% (Andersen et al. 2009). This substantiates the hypothesis that user behaviour is of great importance and is difficult to anticipate. The same trend has been shown with the results gathered from simulations. The greatest variation of heating consumption was found between strategy 1 and 4, if the extreme case of having the radiator turned off at all times is currently ignored. Strategy 1 and 4 include having the windows open at all times and applying the window opening events as registered during the experiment. The difference can be viewed with percentage change which was 499%. Comparing strategy 3 and 4 is somewhat more relevant as these were developed based on more detailed user behaviour and represents reality to a greater extent than the extreme cases modeled with strategy 1 and 2. The percentage change here was 192%.

The results can be viewed in correlation to findings as presented in the work of Garland et al. A handful of residential buildings were analyzed in terms of monitored energy consumption. Variation between the occupants' behaviour regarding opening of doors and windows accounted for a difference in energy consumption of 17% (Gartland et al. 1993).

This change is much lower than the results from simulations. As the setpoints for zone temperatures were fixed, the energy use for heating would increase if windows were held open. That is if the outdoor temperature was lower than indoors. The radiator would supply more heat in order to keep the zone temperature at the setpoint. As stated in Chapter 4.4.2, the reason for having fixed setpoints was to be able to easily compare energy use for the four different cases. However, this introduces a deviation as to how the use of windows would appear in real life scenarios. This can be discussed with an example. If a person generally have the windows open at all times due to comfort preferences of having lower indoor temperatures, they would also probably turn the radiator thermostat down or fully off. Otherwise the cooling strategy with the windows would counteract with the radiator increasing the heat supply in order to keep the indoor temperature at setpoint. Accordingly, the energy use calculated in this IDA ICE model is expected to be higher than a real life scenario. Although lack of knowledge or focus on energy efficient solutions might lead the occupant to pursue such a conflicting operating strategy.

An example more representative to the control strategy with fixed setpoint temperatures includes an office space with more than one occupant. One person might want a lower indoor temperature and as a result turns off the radiator and simultaneously opens the window. The remaining occupants perhaps prefer a higher temperature and keep the radiator next to their desk still on. Then energy use for heating will increase for the radiators that are kept on due to cold draft from the opened window.

Temperatures deviates from recommended standard values. That is within reason and a predicted consequence of user behaviour due to actual perception of comfort. In accordance with the adaptive approach and a manually operated zone, a wider range of temperatures are accepted. For example, if some people tend to always ventilate their room by opening windows they accordingly prefer a lower indoor temperature. Opposite, occupants seemingly prefer higher indoor temperatures if windows are held closed at all times. Suggesting that discomfort in one parameter is somewhat accepted if the action made means that comfort in another parameter is restored. Occupants seem to be willing to make a trade off between comfort parameters.

In terms of applying strategy 2 the indoor temperatures were high with a minimum and maximum operative temperature of 24.16°C and 30.71°C respectively. The week of the experiment the outdoor temperatures were relatively high. As a result the radiator was turned off throughout the simulation period as temperatures were higher than setpoints for heating. A low energy consumption is preferable in regards to the need for energy savings in the building sector. However, such a solution resulted in low indoor environmental quality with high indoor temperatures. As concluded by Sourbron and Helsén, minimization of energy use and maximization of thermal comfort are to some extent conflicting factors. Finding an optimal crossing point is the key. One could discuss that an opening strategy where windows were never opened during a week with weather conditions as the current week is not realistic. This can be seen in correlation to the automatic computer operated test cell, where windows were opened if the indoor air temperature became higher than 25°C improving thermal conditions. However, extreme cases have been included in order to model the extent of user behaviour, which do vary greatly as shown through the literature review. Preferences might not be in accordance with standard requirements. As stated in the work of Oseland, occupants should be provided with a possibility to adapt to the indoor environment. This appears to be the most efficient way of building design in terms of both energy and comfort (Oseland 1995).

As the cell office models were implemented with CAV ventilation the CO_2 levels were kept within the requirement at $1000ppm$ regardless of the window opening strategy. However, the concentration variate. As expected, the CO_2 level was the lowest for strategy 1 where windows were kept open at all times during work hours. Accordingly, the indoor temperatures were low when applying this strategy and within category | of thermal comfort as recommended by NS-EN 15251. The remaining opening strategies resulted in maximum operative temperatures pushing the boundary of category |||.

Emphasizes that the simulations has only been completed for one week. Greater variations would be expected if covering a whole year. However, in order to have reliable results then all compared strategies should be based on recorded user behaviour as climatic conditions were to vary greatly throughout simulations covering a whole year. A fixed opening strategy of applying 10% slot ventilation during work hours is not assumed realistic during all weather conditions throughout the year. Neither is having the windows never opened during summer weather or for example if a situation should occur where the number of occupants increases due to a meeting. Such scenarios would lead to great discomfort in terms of large vertical temperature gradients or draft and overheating. As initiated when presenting strategy 4 in Chapter 4.4.2 this model is more reliable as it has been developed based on registering actual user behaviour. Furthermore, results as listed in Table 5.4 show that this strategy positively gave the lowest heating consumption. That is if the extreme case of having the windows closed and accordingly the radiator turned off is not taken into consideration. It would be of interest to register and analyze window opening strategies for a longer time period and under different climatic conditions.

5.3.3. LIMITATIONS OF THE SIMULATIONS

Completing a simulation provides valuable information when analyzing a given case. The aim for this study has been to replicate the test cell physics and operation. However, a simulation will only ever be an approximation of reality.

In terms of relevance, the results from the test cell simulations are not directly comparable to an actual office building. That is due to the laboratory physics ensuring controlled environmental conditions. Additionally, the results are only specified for a single cell office faced south. Although, in an office building the cell office would be affected by surrounding zones. Therefore, only implementing one single cell office in the model could be seen as a limitation. If a whole building was modeled, there might be variations seen in the results from different zones, due to location in the building or room size etc. Even so, simplicity in a model is an advantage in order to easier understand the results.

Parameters and registered user behaviour gathered during the field work were implemented in the simulation model. Results from questionnaires was used uncritically. This implies that limitations of the experiment as presented in Chapter 5.2.2 will be relevant here too. As a result of the low number of participants, the findings can not be used to draw general conclusions. Lastly, the window setup at the ZEB Test Cell Laboratory did not allow for the degree of window opening to be registered. The sensors solely focused on an opening event. As a result the simplified CELVO model was used when representing window opening percentage as an opening area. This has been further described in Chapter 4.4.1.

A key element of this thesis objective involved the correlation of indoor temperatures perceived as comfortable on outdoor air temperatures. This implies that the climate was of great importance. In the simulation tool, a climate file has been downloaded based on statistical data from a weather station at Værnes, approximately an hour outside of Trondheim city centre. The actual climate of a current day can differ from this standard data. At the ZEB Test Cell Laboratory several measurements were completed on the local weather at the facility. This data has been implemented customizing the standard weather file used in IDA ICE. However, this still did not fully represent the actual weather of the current day, a limitation that has to be noted. That is because not every parameter was updated with local measured values as some of the data was not gathered. The standard climate and wind profile implemented in IDA ICE was based on an average year. Some years might be colder or warmer, or seasons might not be as expected in terms of characteristics. This implies that the actual heating consumption might differ from simulated values. In addition, large amounts of wind might cause thermal discomfort due to draft from windows. Such scenarios with extreme conditions might be difficult to anticipate and account for in advance, but would affect user behaviour.

5.3.4. VALIDATION OF THE SIMULATION MODELS

The simulation models of the two test cells should be validated to ensure they are both reliable and an adequate representation of the laboratory facilities. This will be done by comparing simulation results to measured values on CO_2 concentration, as the indoor environment in terms of air quality has been one of the main focuses of this thesis. The simulation was completed for both models 30.04.18 as that is the relevant day where measurements were gathered at the ZEB Test Cell Laboratory. Figure 5.18 present CO_2 levels measured throughout the day for both test cells. The calculated values from IDA ICE is given in Figure 5.19 for cell A and Figure 5.20 for cell B.

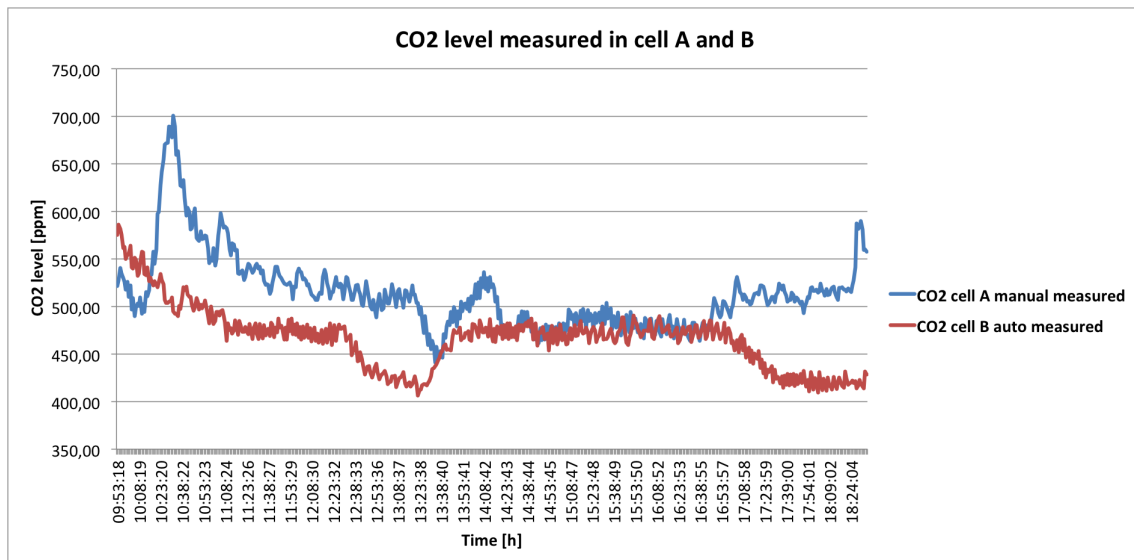

Figure 5.18.: CO_2 level measured in test cell A and B. Data gathered from 30.04.18.

The simulation models can be validated if the calculated CO_2 in IDA ICE correspond to measured levels given in Figure 5.18. Both test cells need to be analyzed as the operation strategies are different and developed in IDA ICE as two separate models and separate files. Note that measurements presented from the test cell facility were given for each minute. In IDA ICE the timesteps were varied and calculations given with smoothed curves. Consequently this is the first cited reason for observed deviations in the results.

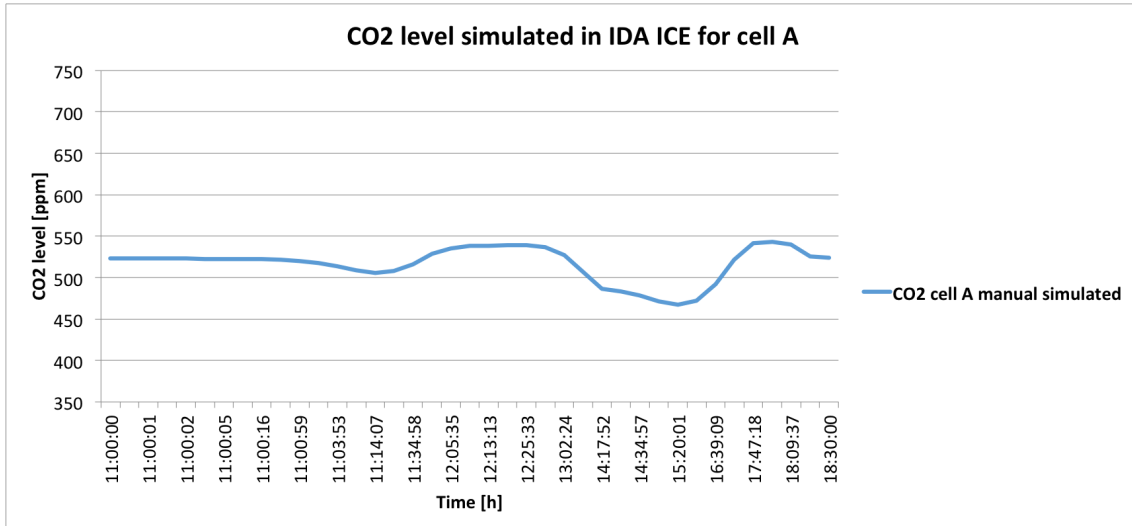

Figure 5.19.: CO_2 level calculated in IDA ICE for test cell A. Data gathered from 30.04.18.

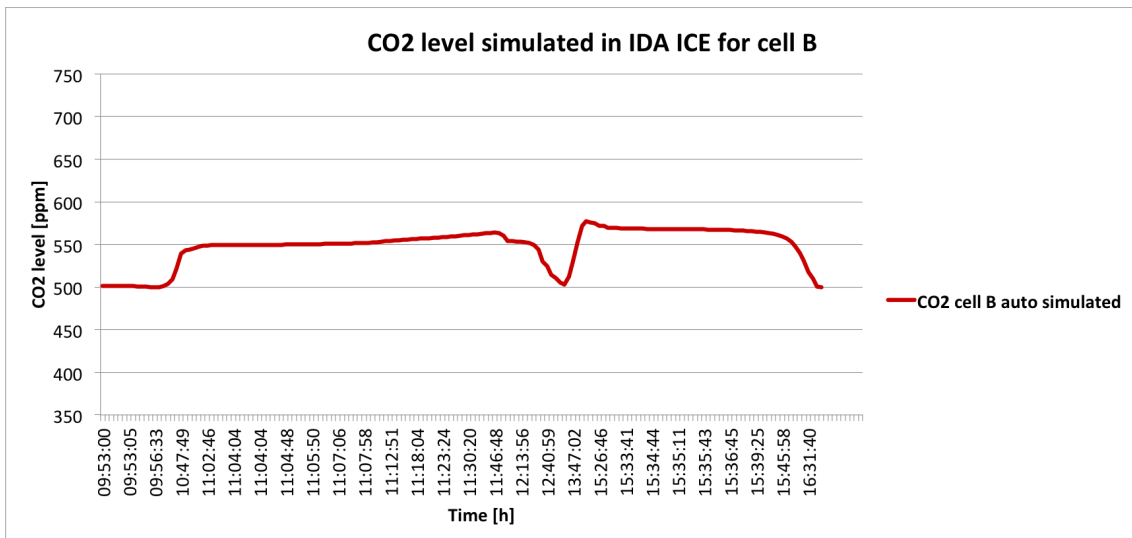

Figure 5.20.: CO_2 level calculated in IDA ICE for test cell B. Data gathered from 30.04.18.

The main events registered through measurements in Figure 5.18 will be compared to simulated values for both test cell models. By analyzing Figure 5.19 it can be seen that variations in the CO_2 level as calculated correspond to those measured for cell A. Participant 2 arrived at the ZEB Test Cell Laboratory at 09:30. The window was opened 10:24. However, due to mandatory startup interviews that was completed outside of the test cells the occupant did not enter cell A to work until 11:00. Lunch at 13:18 was registered in the

simulation model and the CO_2 level decreased correctly at some time after 13:02 on the time axis. Just after 14:17 there was a further drop in the calculated CO_2 concentration. That is due to the window being opened at a wider angle. Furthermore, there was an increase as the window was put back as a side hung casement at 16:35. The curve drops and stagnates some time after 18:00 as the window was fully closed at 18:21 and the occupant left the test cell for the day at 18:30. Accordingly, there has been shown a correspondence between simulated and measured CO_2 levels. That is expected as occupancy and window opening events has been included in IDA ICE as detailed schedules.

Participant 1 arrived in cell B at approximately 09:53. In Figure 5.20 this is shown as the CO_2 level increases. Both curves for measurements and the simulation follow the same pattern. A reduction articulated in two steps can be observed right after 12:00 as the occupant left the cell for the main break, and the curve follow the same pattern as for measured values presented in Figure 5.18. The automatic window was open almost the entire day and not closed before after the participant left for the day. A reduction was found just after 16:00 as the occupant left. The events again correspond to registered conditions in the test cell.

Although the simulation models do present main events, the level of values are slightly different. For example the main peaks at the beginning of the day did not show up on the graph completed by simulations. The simulations were only completed for the current day and only for the limited time of occupancy for the relevant participant. At the test cell facility accumulated CO_2 from the previous day could be one reason for higher initial levels, especially for test cell A where windows needed to be opened manually. Another explanation is that the first hours of the day before the actual experiment started, those in charge viewed the test cell with the participants providing necessary information. Pictures taken on the installed web cameras revealed that up to four people were present in the test cells during the morning hours. In the simulation model only one occupant was included not entering the zone until the specified time where experiments started. Note however that the variation is small, and for the rest of the day both simulated and measured values variate between 400ppm and 550ppm. For both simulations, the CO_2 concentrations were well within the requirement of 1000ppm.

As initiated in Chapter 4.4.1, one limitation is how IDA ICE model window opening, which is most different to the window type installed in the test cells. Again, in IDA ICE the total window area is reduced according to the percentage of opening not taking the tilted window position or varying c_d coefficient into consideration. This could be one reason why the measured CO_2 levels drop lower than calculations show in IDA ICE. Contrary, the fact that the weather file has been customized with data measured at the ZEB Test Cell Laboratory weather station increases correspondence between simulations and the laboratory. Because then outdoor temperatures and wind, important factors, are not based on a standard year most likely to differ from actual conditions. Further limitations potentially affecting reliability of the results are as presented in the previous section, Chapter 5.3.3.

5.4. REGRESSION ANALYSIS OF WINDOW OPENING EVENTS

Participants had the possibility to report back if any changes had been made and why through the questionnaires. Additionally, sensor measurements were used to define thermal environmental parameters at the time of the questionnaires. Table 5.5 present registered situations during the day where windows have been opened. Window opening methods are again correlated to a fixed percentage of opening as presented in Table 4.15.

Based on user feedback and measurements, the opening of windows have been correlated to indoor and outdoor temperatures, CO_2 level and solar radiation. The participants did not report back that opening of windows was due to poor quality of indoor air and perceived the air quality as clearly acceptable. Regardless, the CO_2 level has been included as the indoor environment in terms of air quality is one of the focuses of this thesis. Other parameters can be of influence such as activity level, clothing level, other climatic parameters or for example gender and age. These factors will not be taken into consideration in order to limit complexity.

In regards to the factors that caused the occupants to open the windows, it is possible to imitate user behaviour also outside the exact week the study was completed. That is under similar conditions and range as of the fundamental parameters. This implies that data can possibly be used to identify window opening strategies during spring and autumn. The summer and winter seasons are assumed to have too large climatic differences.

With a basis of the instances listed in Table 5.5, the statistical tool regression analysis will be utilized. The aim is to develop an equation that state an opening event in regards to the determining factors.

Table 5.5.: Registered scenarios where the user opened a part of the window in cell A.
Data gathered from 30.04.18-04.05.18.

Observation number	Window opening event [%]	T_{op} [°C]	T_{out} [°C]	CO_2 [ppm]	I_{rad} [W/m ²]
1	10	23.389676	5.700000	527.858111	485.000000
2	40	25.596023	9.300000	487.569755	623.000000
3	10	24.084199	9.200000	564.233238	105.000000
4	10	23.709934	9.200000	455.183211	504.000000
5	10	24.068312	9.500000	475.088125	487.000000
6	10	23.269418	12.800000	481.723097	127.000000
7	10	23.276348	12.900000	470.423938	302.000000
8	10	24.204414	11.800000	425.884228	140.000000
9	10	25.963186	11.400000	443.292816	335.000000
10	40	25.602034	13.700000	497.686444	519.000000

Multivariable regression analysis will be applied in Excel on the listed observations. Window opening percentage is the dependent or response variable. Operative temperature, outdoor temperature, CO_2 level and solar radiation are the independent explanatory variables. The linear model revealing the relationship between these variables can be formulated with the general model as given in Equation 5.2. The coefficients represent the increment in the response variable corresponding to a unit increase in the relevant explanatory variable. That is a β_k increment in y corresponding to a unit increase in x_k .

$$y = \beta_0 + \beta_1 * x_1 + \beta_2 * x_2 + \dots + \beta_k * x_k \quad (5.2)$$

List of symbols:

- y is the response variable
- $\beta_0, \beta_1, \beta_2, \dots, \beta_k$ are the regression coefficients
- x_1, x_2, \dots, x_k are the explanatory variables
- k is the number of coefficients

Regression statistics gathered from the multivariable regression analysis in Excel is presented in Table 5.6. Values regarding the degree of freedom follows in Table 5.7, which describes the number of parameters that might vary independently. A summary of outputs concerning the coefficients is presented in Table 5.8.

Table 5.6.: Regression statistics.

Parameter	Value
Observations, n	10
R^2	0.78019693

Table 5.7.: Degrees of freedom.

Parameter	df
Regression, k	4
Residual, n-k-1	5
Total, n-1	9

Table 5.8.: Summary outputs on coefficients.

Parameter	Coefficients	P-value
Intercept	-207.25046	0.04711
T_{op}	4.66868	0.18254
T_{out}	2.73797	0.10993
CO_2	0.13562	0.12765
I_{rad}	0.04232	0.05954

Based on the data presented in Table 5.8 the regression equation can be obtained, and is given in Equation 5.3.

$$y = -207.25 + 4.67 * T_{op} + 2.74 * T_{out} + 0.14 * CO_2 + 0.04 * I_{rad} \quad (5.3)$$

List of symbols:

- y is the window opening in [%]
- T_{op} is the operative temperature in [°C]
- T_{out} is the outdoor temperature in [°C]
- CO_2 is the relevant concentration in [ppm]
- I_{rad} is the solar radiation in [W/m^2]

The coefficients relate a unit variation in the given parameter to the variation in y . For example, if the operative temperature should increase with 1°C the window opening is assumed to increase with 4.67% accordingly. The R^2 value listed in Table 5.6 defines to what extent the parameters describe the variability of y . For this calculation it is approximately 0.78 and the chosen parameters explain 78% of the variability in window opening percentage. This implies that the listed parameters is of great influence. However, there are other factors not taken into consideration that affects window opening percentage. As initiated earlier in this subchapter, other parameters are assumed to affect user behaviour in terms of window opening. Examples include activity level, clothing level or other climatic parameters such as wind or humidity. Unless every parameter of influence are included in the model the coefficient of determination obtained will be less than 1 or 100%.

The significance of a given parameter is represented with the P-value, or probability value, as given in Table 5.8. A low P-value indicates that the parameter is a meaningful addition to the model, and that a variation in the given parameter results in a significant variation in the response variable. Conversely, a higher P-value indicates that the parameter is not highly associated with variations in the response. The lowest P-value for this data set was given for I_{rad} . This implies that a change in solar radiation affects the window opening percentage to a great extent. Furthermore, the outdoor temperature was assumed to affect the window opening to a greater extent than the CO_2 concentration. Hence, the outdoor climate seem to have a great impact on how users chooses to operate windows according to this model. Although a p-value lower than 0.05 is often preferred in order to state that the model is significant and to fully reject the null hypothesis. A low p-value indicates that the results are valid and not random possibly changing with a second test.

The operative temperature was associated with a high P-value and it is suggested that a variation in this parameter does not result in as great of a variation in window opening percentage. Removing operative temperature from the model resulted in lower P-values for the remaining parameters and accordingly a higher significance. Although when removing one parameter the R^2 is reduced as there as less factors defining the variance in y . By looking at the data for the listed observations in Table 4.11, it becomes clear that during the experiment there was minimal variation in operative temperature. Solar radiation however and outdoor temperature were more varied. A wider range of climatic- and indoor environmental conditions for the listed observations would increase applicability of the model. In advance of completing this regression analysis, the operative temperature was assumed to be of great influence based on background knowledge obtained from relevant literature. A model developed based on a larger number of observations would be preferable and is assumed to result in a more representative model. Measuring the window opening instead of setting a fixed percentage would also improve the model.

6. CONCLUSION

The aim of this master's thesis has been to research user controllability in correlation to thermal comfort, indoor air quality and energy performance. This involved completing field work at the ZEB Test Cell Laboratory in Trondheim and performing simulations in IDA ICE version 4.7.1. The building type of focus has been cell offices.

Experiments were carried out simultaneously in two separated but identical test cells having one occupant present in each cell. One chamber was manually operated whilst the other was automatically controlled. Both measurements and questionnaires were gathered. User behaviour as registered during the experimental work was implemented into IDA ICE simulating a model of the test cell. Note that the results reflect key findings from a case study which is based on a low number of participants. Hence, no general conclusions could be drawn. Although, comparing findings to relevant literature showed reappearing trends.

The primary aim has been to research comfort preferences in correlation to the users feasibility to control indoor environmental parameters. Accordingly, a relevant research question has been regarding whether or not the participants of the case study rated thermal sensation differently when the zone was automatically optimized providing no user controllability, or when occupants had the possibility to affect the control strategies. Thermal sensation votes correlated to the seven-point scale were gathered from the questionnaires. The occupant in the user operated cell had all except two votes at neutral. For comparison, the participant in the automatic cell perceived the indoor environment as slightly warm and slightly cool for large portions of the day. Additionally, the occupant in the automatic cell expressed a desire to operate the controls differently than the fixed strategies. A difference in ratings of thermal sensation due to operating strategies has been shown. However, variations in gender, age, ethnicity, clothing level and individual preferences could also have affected the outcome.

The participants rated the current temperature through questionnaires on a four-point scale ranging from clearly acceptable to clearly unacceptable. It has been analyzed to what extent the occupants' acceptable indoor temperature was affected by the user feasibility to control the indoor environment. Participant 2 in the manual cell perceived registered temperatures as clearly acceptable throughout the entire day with temperatures ranging from 22.1°C to 25.9°C. For the participant in the automatic cell the registered votes were stable at clearly acceptable from a temperature of 23.7°C up to 25.4°C. The temperature increased slightly to 25.6°C and 25.7°C and was then rated just acceptable by the occupant. As the highest temperature rated as clearly acceptable for the participant in the manual cell was 25.9°, this resulted in a difference in perceived maximal temperature of 0.3° between the two test cells. The slight variation in accepted temperatures could be due to availability of controls. User control provide occupants with the possibility to more actively optimize conditions directly based on individual state and preference.

The case day and physics of the test cells were implemented into IDA ICE as detailed as possible. The simulation models were used to calculate standard comfort indices in accordance with Fanger's model, which was compared to thermal sensation votes gathered

from the questionnaires. The aim was to discover if the participants of the case study represented a standard vote in correlation to the PMV model. The concurrence between calculated and observed thermal sensation votes were most evident for the computer operated cell. As predicted with simulation results, the occupant in the automatic cell perceived the environment as neutral and slightly warm. For the manually operated cell however, the standard calculations failed to predict thermal sensation. The participant did not rate the thermal environment slightly cool as predicted by standard votes gathered from IDA ICE, but in reality neutral and slightly warm.

User behaviour and its affect on energy use was researched by simulating four different window opening strategies in IDA ICE. That is having the windows 1) always open applying slot ventilation, 2) never open, 3) based on season, indoor and outdoor temperature and CO_2 and 4) as registered during the experiments in the manual test cell. The relevant research aim has been to analyze to what extent the energy consumption for heating was affected by user behaviour. Weather data gathered during the specific week was included in the downloaded climate file in IDA ICE. Relatively high outdoor temperatures and sun dominated the week of experiments resulting in operative indoor temperatures exceeding standard recommendations. When completing simulations where windows were held closed at all times the radiator was turned off accordingly. The greatest difference in heating consumption resulted in a percentage change of 499%. That was for the simulation models on strategy 1) and 4). A lower percentage change was found when comparing strategy 3) and 4). That was 192%. Fixed setpoints were applied for the waterbased radiator when modelling all four window operation strategies. As a result the radiator would supply more heat if windows were held opened. In reality occupants are assumed to turn off the radiator thermostat if windows are opened and not pursue such a conflicting operating strategy.

Registered window opening events throughout the week of experiments in the manual cell were correlated to operative temperature, outdoor temperature, CO_2 level and solar radiation. Applying multivariable regression analysis in Excel showed that window opening percentage and the relevant parameters can be correlated with the following equation. The parameters explain 78% of the variability in window opening percentage. The outdoor climate seem to have a great impact on how users choose to operate windows as solar radiation and outdoor temperature were associated with low probability values and accordingly high significance.

$$y = -207.25 + 4.67 * T_{op} + 2.74 * T_{out} + 0.14 * CO_2 + 0.04 * I_{rad}$$

This thesis is of relevance to research on energy saving potential in the building sector. Relevant literature has demonstrated a need for measures with immediate affect. The completed case study has shown that unnecessary energy use correlated to automatic operation of fixed strategies does not result in a higher level of comfort. Actually, rather opposite. A great share of relevant research have been completed in zones with warm or moderate climatic conditions. This thesis is therefore a contribution to the field of study covering a cold climate. Although, due to a delay the startup date was postponed until May, the beginning of summer. It would be of interest to complete studies during all seasons containing a larger group of participants.

7. FURTHER WORK

A list of suggestions for further work follows. These are founded based on the literature review revealing state of the art as well as key findings and viewed limitations of this thesis.

- Complete case studies on perceived thermal comfort and user behaviour including a larger group of participants further containing a variety of gender and age.
- Research thermal comfort and energy use for longer time periods during all seasons of a colder climate.
- Analyze the difference in total energy use for a variation of operating strategies and asses the preferred balance between low energy use and high user controllability.
- It would be of interest to carry out questionnaires and measurements similar as to what has been done during the test cell experiment at an actual office. If so, valuable data could be gathered from subjects present in their known environment.
- Study user controllability of the indoor environment taking more parameters into consideration. Examples include physical, physiological, behavioral and psychological factors affecting thermal comfort, as well as climatic parameters such as wind or humidity.
- Large scale simulations implementing an entire building to study user behaviour affects on thermal comfort and energy use.
- Develop models on window opening strategies to analyze the effects on energy use. These should be based on registered user behaviour covering all climatic seasons.

BIBLIOGRAPHY

BIBLIOGRAPHY

- Alfano, Francesca Romana d'Ambrosio et al. (2014). "Thermal comfort: Design and assessment for energy saving". In: *Energy and Buildings* 81, pp. 326–336.
- Andersen, Rune Vinther et al. (2009). "Survey of occupant behaviour and control of indoor environment in Danish dwellings". In: *Energy and Buildings* 41.1, pp. 11–16.
- Arens, Edward et al. (2010). "Are 'class A' temperature requirements realistic or desirable?" In: *Building and Environment* 45.1, pp. 4–10.
- Axel Bring Per Sahlin, Mika Vuolle (1999). "Models for Building Indoor Climate and Energy Simulation". In:
- Brager, Gail, Gwelen Paliaga, and Richard De Dear (2004). "Operable windows, personal control and occupant comfort." In:
- Brager, Gail S and Richard De Dear (2001). "Climate, comfort and natural ventilation: a new adaptive comfort standard for ASHRAE standard 55". In:
- Brager, Gail S and Richard J de Dear (1998). "Thermal adaptation in the built environment: a literature review". In: *Energy and buildings* 27.1, pp. 83–96.
- Brager, Gail Schiller and Richard de Dear (2000). "A standard for natural ventilation". In: *ASHRAE journal* 42.10, p. 21.
- Cattarin, G et al. (2017). "Empirical validation and local sensitivity analysis of a lumped-parameter thermal model of an outdoor test cell". In: *Building and Environment*.
- Chatonnet, J and M Cabanac (1965). "The perception of thermal comfort". In: *International Journal of Biometeorology* 9.2, pp. 183–193.
- Clements-Croome, Derek et al. (2006). *Creating the productive workplace*. Taylor & Francis.
- De Dear, Richard J et al. (1998). "Developing an adaptive model of thermal comfort and preference/discussion". In: *ASHRAE transactions* 104, p. 145.
- Dear, Richard de (2011). "Revisiting an old hypothesis of human thermal perception: alliesthesia". In:
- (2015). *Thermal counterpoint in urban climate - Alliesthesia*. University Lecture.
- Del Ferraro, S et al. (2015). "A field study on thermal comfort in an Italian hospital considering differences in gender and age". In: *Applied ergonomics* 50, pp. 177–184.
- Direktoratet for byggkvalitet (2017). *Byggteknisk forskrift (TEK 17)*.

- Donnini, Giovanna et al. (1997). *Field study of occupant comfort and office thermal environments in a cold climate*. Tech. rep. American Society of Heating, Refrigerating and Air-Conditioning Engineers, Inc., Atlanta, GA (United States).
- Fanger, P Ole and Jørn Toftum (2002). “Extension of the PMV model to non-air-conditioned buildings in warm climates”. In: *Energy and buildings* 34.6, pp. 533–536.
- Farlex and Partners (2017). *Medical Dictionary*. URL: <http://medical-dictionary.thefreedictionary.com/alliesthesia> (visited on 10/09/2017).
- Fisk, William J (2000). “Health and productivity gains from better indoor environments and their relationship with building energy efficiency”. In: *Annual Review of Energy and the Environment* 25.1, pp. 537–566.
- Fountain, M and Edward A Arens (1993). “Air movement and thermal comfort”. In:
- Gartland, LM et al. (1993). “Residential energy usage and the influence of occupant behavior”. In: *Proceedings of the ASME Winter Conference*. Publ by ASME.
- Goia, Francesco, Christian Schlemminger, and Arild Gustavsen (2017). “The ZEB Test Cell Laboratory. A facility for characterization of building envelope systems under real outdoor conditions”. In: *Energy Procedia* 132, pp. 531–536.
- Google. *Google Maps*. URL: <https://www.google.no/maps/@63.4142327,10.408643,18.44z> (visited on 04/25/2018).
- Halawa, E and J Van Hoof (2012). “The adaptive approach to thermal comfort: A critical overview”. In: *Energy and Buildings* 51, pp. 101–110.
- Havenith, George, Ingvar Holmér, and Ken Parsons (2002a). “Personal factors in thermal comfort assessment: clothing properties and metabolic heat production”. In: *Energy and buildings* 34.6, pp. 581–591.
- (2002b). “Personal factors in thermal comfort assessment: clothing properties and metabolic heat production”. In: *Energy and buildings* 34.6, pp. 581–591.
- Hellwig, RT, Sabine Brasche, and W Bischof (2006). “Thermal Comfort in Offices–Natural Ventilation vs. Air Conditioning”. In: *Proceedings of congress Comfort and Energy Use in Buildings–Getting it Right, Windsor*.
- Huizenga, Charlie et al. (2006). “Air quality and thermal comfort in office buildings: results of a large indoor environmental quality survey”. In:
- Humphreys, Michael A and J Fergus Nicol (1998). “Understanding the adaptive approach to thermal comfort”. In: *ASHRAE transactions* 104, p. 991.
- Hunt, DRG and MI Gidman (1982). “A national field survey of house temperatures”. In: *Building and environment* 17.2, pp. 107–124.
- Ingebrigsten (2017a). *Ventilasjonsteknikk Del //*. Skarland Press AS.
- (2017b). *Ventilasjonsteknikk Del /*. Skarland Press AS.
- Li, Baizhan et al. (2012). “The Chinese evaluation standard for the indoor thermal environment in free-running buildings”. In: *Proceedings of 7th Windsor Conference: the*

- changing context of comfort in an unpredictable world Cumberland Lodge, Windsor, UK*, pp. 12–5.
- Luc Pénicaud Dominique Valentin, Laurent Brondel (2016). “Mechanisms involved in the control of feeding behavior in relation to food flavor”. In:
- McCartney, Kathryn J and J Fergus Nicol (2002). “Developing an adaptive control algorithm for Europe”. In: *Energy and buildings* 34.6, pp. 623–635.
- Morgan, Craig and Richard de Dear (2003). “Weather, clothing and thermal adaptation to indoor climate”. In: *Climate Research* 24.3, pp. 267–284.
- Mower, George D (1976). “Perceived intensity of peripheral thermal stimuli is independent of internal body temperature.” In: *Journal of comparative and physiological psychology* 90.12, p. 1152.
- Nicol, J Fergus (2001). “Characterising occupant behaviour in buildings: towards a stochastic model of occupant use of windows, lights, blinds, heaters and fans”. In: *Proceedings of the seventh international IBPSA conference, Rio*. Vol. 2, pp. 1073–1078.
- (2011). *Adaptive comfort*.
- Norsk Standard, NS-EN 15251 (2014). *Inneklimaparametre for dimensjonering og vurdering av bygningers energiytelse inkludert inneluftkvalitet, termisk miljø, belysning og akustikk*.
- Norsk Standard, NS-EN ISO 7730 (2006). *Ergonomics of the thermal environment. Analytical determination and interpretation of thermal comfort using calculation of the PMV and PPD indices and local thermal comfort criteria. (ISO 7730:2005)*.
- NTNU. *FME ZEN*. URL: <https://www.ntnu.no/zen> (visited on 02/06/2018).
- NTNU, SINTEF (2016). “Pressemelding, ZEN blir nytt Forskningscenter for miljøvennlig energi”. In:
- NTNU SINTEF (2007). *Enøk i bygninger - effektiv energibruk*. Gyldendal undervisning 3.utgave.
- Oseland, Nigel A (1995). “Predicted and reported thermal sensation in climate chambers, offices and homes”. In: *Energy and Buildings* 23.2, pp. 105–115.
- P. O. Fanger (1970). *Thermal comfort. Analysis and Applications in Environmental Engineering*. Danish Technical Press.
- Parkinson, Thomas and Richard de Dear (2015). “Thermal pleasure in built environments: physiology of alliesthesia”. In: *Building Research & Information* 43.3, pp. 288–301.
- Parkinson, Thomas, Richard de Dear, and Christhina Candido (2012). “Perception of Transient Thermal Environments: pleasure and alliesthesia”. In: *Proceedings of 7th Windsor Conference, Windsor, UK*.
- (2016). “Thermal pleasure in built environments: alliesthesia in different thermoregulatory zones”. In: *Building Research & Information* 44.1, pp. 20–33.
- Raja, Iftikhar A et al. (2001). “Thermal comfort: use of controls in naturally ventilated buildings”. In: *Energy and Buildings* 33.3, pp. 235–244.

- Schaudienst, Falk and Frank U Vogdt (2017). “Fanger’s model of thermal comfort: a model suitable just for men?” In: *Energy Procedia* 132, pp. 129–134.
- SINTEF. *SkinTech*. URL: <https://www.sintef.no/projectweb/skintech/> (visited on 02/06/2018).
- Skeie, Stina (2017). “Thermal comfort and energy use for cooling and heating in non-residential buildings”. In:
- Sourbron, Maarten and Lieve Helsen (2011). “Evaluation of adaptive thermal comfort models in moderate climates and their impact on energy use in office buildings”. In: *Energy and Buildings* 43.2, pp. 423–432.
- StatisticsNorway (2018). *SSB Befolkning*. URL: <https://www.ssb.no/befolkning/faktaside/befolkningen> (visited on 04/17/2018).
- Toftum, Jørn (2010). “Central automatic control or distributed occupant control for better indoor environment quality in the future”. In: *Building and environment* 45.1, pp. 23–28.
- TU. *Smarte fasader*. URL: <https://www.tu.no/artikler/fremtidens-fasader-skal-spekkes-med-teknologi/347374> (visited on 02/06/2018).
- Van Hoof, Joost and Jan LM Hensen (2007). “Quantifying the relevance of adaptive thermal comfort models in moderate thermal climate zones”. In: *Building and Environment* 42.1, pp. 156–170.
- Wagner, A et al. (2007). “Thermal comfort and workplace occupant satisfaction—Results of field studies in German low energy office buildings”. In: *Energy and Buildings* 39.7, pp. 758–769.
- ZEB. *Test Cell Laboratory*. URL: <http://www.zeb.no/index.php/en/test-cell-laboratory> (visited on 02/06/2018).

APPENDIX

A. MEASURING EQUIPMENT FIELD WORK

- Air temperature

- Resistant temperature detector
- Pt100
- Range: $-5\dots+60^{\circ}\text{C}$
- Accuracy: $\pm 0.3^{\circ}\text{C}$
- 3 sensors; $h=0.26\text{m}$, $h=0.65\text{m}$, $h=1.10\text{m}$
- Placed on a tripod at the left hand side of the office desk, 1m from the external surface.



Figure A.1.: Sensor measuring air temperature.

- Surface temperature

- T-type thermocouple
- Accuracy: $\pm 0.4^{\circ}\text{C}$
- 16 sensors evenly distributed; 5 west internal wall, 5 east internal wall, 3 ceiling, 3 floor



Figure A.2.: Thermocouple sensor measuring surface temperature.

- Radiant temperature

- Thermocouple black ball
- Pt100
- Range: $-5\dots+60^{\circ}\text{C}$
- Accuracy: $\pm 0.3^{\circ}\text{C}$
- 1 sensor; $h=0.90\text{m}$
- Placed on a tripod at the left hand side of the office desk, 1m from the external surface.



Figure A.3.: Thermocouple black ball measuring the radiant temperature.

- Lux level

- S+S REGELTECHNIK GMBH, PHOTASGARD RHKF-U
- Measuring error: $< 5\%$ of final value
- 2 sensors; ceiling, on the desk at 0.85m height



Figure A.4.: Sensor measuring light level.

- Relative humidity

- S+S REGELTECHNIK GMBH, HYSGRASGARD RFTF PT100 FRIJA ||
- Range: 0 – 100% r.H.
- Accuracy: $\pm 5\%$
- 1 sensor; internal wall at 1.70m height



Figure A.5.: Sensor measuring the relative humidity.

- CO₂ level

- S+S REGELTECHNIK GMBH, AERASGARD RC02 FRIJA ||
- Range: 0 – 2000ppm
- Accuracy: $\pm 70ppm + 5\%_{measured}$
- 1 sensor; internal wall at 1.70m height



Figure A.6.: Sensor measuring the CO₂ level.

- Air velocity
 - Sensore microclima, lsi lastem
 - Anemometer
 - Range: 0-20m/s
 - 3 sensors; h=0.26m, h=0.65m, h=1.10m
 - Placed on a tripod at the left hand side of the office desk, 1m from the external surface.



Figure A.7.: Anemometer measuring air velocity.

- Weather station
 - External air temperature
(Pt100; range: -40...+60°C; accuracy: $\pm 0.15^{\circ}C + 0.1\%_{measured}$)
 - Solar irradiance
(Pyranometers; range: 0...2000W/m²; accuracy: II class pyranometer)
 - Outdoor air relative humidity
(Capacitive; range: 0...100%_{rh}; accuracy: $\pm 1.5\%_{rh} + 1.5\%_{measured}$)
 - Wind speed
(Ultrasound; range: 0...60m/s; accuracy: $\pm 3\%$)
 - Wind direction
(Ultrasound; range: 0...360°; accuracy: $\pm 2^{\circ}$)

B. CALIBRATION OF THE ANEMOMETERS

This section aims to present data from the calibration process. That includes calibration of six anemometers, three in each test cell. The calibration was completed the 28.05.18 at the ZEB Test Cell Laboratory in Trondheim. The equipment utilized is rendered in the list below. A further description of the procedure is given in Chapter 3.4.4.

Equipment used in the calibration process:

- TSI calibrator model 1125. Reg. Nr. vvs-464
- PPC 500 Pressure Calibrator
- Anemometers. Sensore microclima, lsi lastem
- Compressor

Calibration data is given in Figure B.1 and Figure B.2 for the automatic and manual test cell respectively. Data has been correlated to the sensor code as listed. The setpoint in velocity was reached by regulating the flow until the manometer registered the corresponding pressure in Pascal. Measurements gathered by the anemometers was registered in LabVIEW as voltage. Figure B.3 to Figure B.8 show the setpoints in velocity plotted versus the average voltage measured. Linear regression was applied for every anemometer and the equations for best linear fit have been summarized in Figure B.9. Y is the air velocity in $[m/s]$ whilst X is the average voltage in $[mV]$.

Raw data has been included in LabVIEW for each anemometer which correlated voltage to velocity. LabVIEW considered the data as linear according to the values obtained after tuning. Figure B.10 shows this data listed for each sensor. Linear regression equations have been developed based on the raw data. Here Y represents voltage in $[mV]$ and X the air velocity in $[m/s]$. Measurements gathered during the week of experiments was given in $[m/s]$ whilst the calibration data was gathered in $[mV]$ as explained. The data from LabVIEW given in Figure B.10 and the correlated linear regression equations was used to transform the air velocities measured during the experiment to $[mV]$. The fitted curves based on the calibration data was then applied to the measurements given in $[mV]$. This limited the uncertainty and simultaneously converted the data back to $[m/s]$.

APPENDIX B. CALIBRATION OF THE ANEMOMETERS

Sensor code	Setpoint pressure manometer [Pa]	Setpoint velocity [m/s]	Average voltage measured anemometer [mV]
A.ANEM2	97,2492	0,1	81,64119
A.ANEM2	391,0872	0,2	83,21041
A.ANEM2	882,0172	0,3	85,57375
A.ANEM2	1570,0392	0,4	87,64433
A.ANEM2	2455,1532	0,5	89,36733
A.ANEM2	3537,3592	0,6	90,02861
A.ANEM2	4816,6572	0,7	92,3618
A.ANEM2	3537,3592	0,6	91,83197
A.ANEM2	2455,1532	0,5	90,79695
A.ANEM2	1570,0392	0,4	88,39813
A.ANEM2	882,0172	0,3	88,08169
A.ANEM2	391,0872	0,2	86,94392
A.ANEM2	97,2492	0,1	84,29264
A.ANEM3	2	0	81,80034
A.ANEM3	97,2492	0,1	83,20962
A.ANEM3	391,0872	0,2	85,15697
A.ANEM3	882,0172	0,3	86,40528
A.ANEM3	1570,0392	0,4	86,60581
A.ANEM3	2455,1532	0,5	87,63018
A.ANEM3	3537,3592	0,6	87,42484
A.ANEM3	4816,6572	0,7	88,91745
A.ANEM3	3537,3592	0,6	90,22684
A.ANEM3	2455,1532	0,5	88,50988
A.ANEM3	1570,0392	0,4	86,37872
A.ANEM3	882,0172	0,3	84,72292
A.ANEM3	391,0872	0,2	83,81552
A.ANEM3	97,2492	0,1	82,49596
A.ANEM4	4	0	76,6959
A.ANEM4	97,2492	0,1	77,1797
A.ANEM4	391,0872	0,2	79,07849
A.ANEM4	882,0172	0,3	79,35678
A.ANEM4	1570,0392	0,4	81,34296
A.ANEM4	2455,1532	0,5	82,08233
A.ANEM4	3537,3592	0,6	84,56656
A.ANEM4	4816,6572	0,7	85,70357
A.ANEM4	3537,3592	0,6	83,92187
A.ANEM4	2455,1532	0,5	82,96194
A.ANEM4	1570,0392	0,4	82,16917
A.ANEM4	882,0172	0,3	79,53834
A.ANEM4	391,0872	0,2	77,96117
A.ANEM4	97,2492	0,1	76,53629

Figure B.1.: Calibration data for anemometers installed in the automatic test cell.

APPENDIX B. CALIBRATION OF THE ANEMOMETERS

Sensor code	Setpoint pressure manometer [Pa]	Setpoint velocity [m/s]	Average voltage measured anemometer [mV]
B.ANEM2	10	0	85,06485
B.ANEM2	97,2492	0,1	86,66458
B.ANEM2	391,0872	0,2	87,56635
B.ANEM2	882,0172	0,3	90,33429
B.ANEM2	1570,0392	0,4	91,54541
B.ANEM2	2455,1532	0,5	94,05126
B.ANEM2	3537,3592	0,6	93,68416
B.ANEM2	4816,6572	0,7	95,82028
B.ANEM2	3537,3592	0,6	94,15163
B.ANEM2	2455,1532	0,5	92,63343
B.ANEM2	1570,0392	0,4	91,17179
B.ANEM2	882,0172	0,3	90,45326
B.ANEM2	391,0872	0,2	89,30671
B.ANEM2	97,2492	0,1	86,50358
B.ANEM3	0	0	84,57544
B.ANEM3	97,2492	0,1	85,37448
B.ANEM3	391,0872	0,2	88,06399
B.ANEM3	882,0172	0,3	89,0218
B.ANEM3	1570,0392	0,4	90,058
B.ANEM3	2455,1532	0,5	92,50652
B.ANEM3	3537,3592	0,6	89,399
B.ANEM3	4816,6572	0,7	92,54828
B.ANEM3	3537,3592	0,6	90,7858
B.ANEM3	2455,1532	0,5	89,54276
B.ANEM3	1570,0392	0,4	88,61282
B.ANEM3	882,0172	0,3	87,88253
B.ANEM3	391,0872	0,2	86,9819
B.ANEM3	97,2492	0,1	85,57953
B.ANEM4	2	0	18,61182
B.ANEM4	97,2492	0,1	19,54584
B.ANEM4	391,0872	0,2	23,00643
B.ANEM4	882,0172	0,3	25,26338
B.ANEM4	1570,0392	0,4	26,59117
B.ANEM4	2455,1532	0,5	29,58437
B.ANEM4	3537,3592	0,6	30,52199
B.ANEM4	4816,6572	0,7	31,53183
B.ANEM4	3537,3592	0,6	30,54071
B.ANEM4	2455,1532	0,5	29,35085
B.ANEM4	1570,0392	0,4	26,18292
B.ANEM4	882,0172	0,3	24,97327
B.ANEM4	391,0872	0,2	22,2717
B.ANEM4	97,2492	0,1	19,94221

Figure B.2.: Calibration data for anemometers installed in the manual test cell.

APPENDIX B. CALIBRATION OF THE ANEMOMETERS

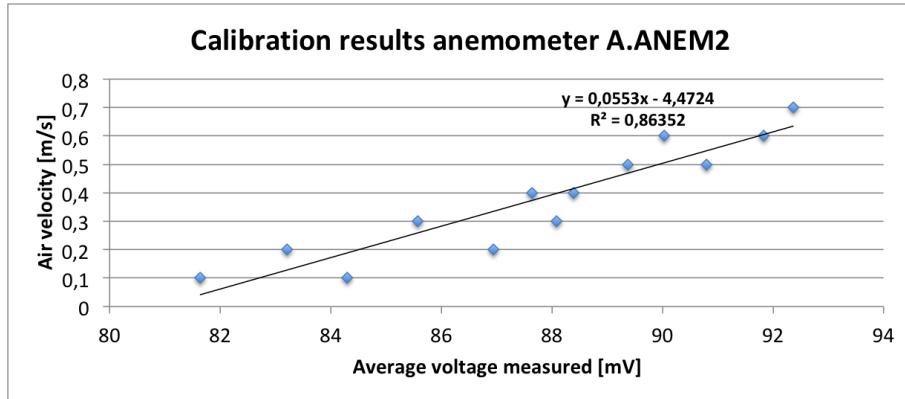

Figure B.3.: Regression analysis on calibration data for anemometer A.ANEM2.

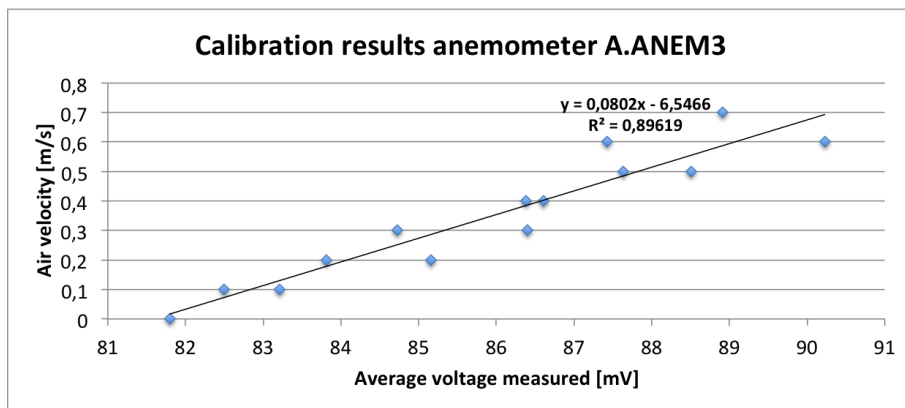

Figure B.4.: Regression analysis on calibration data for anemometer A.ANEM3.

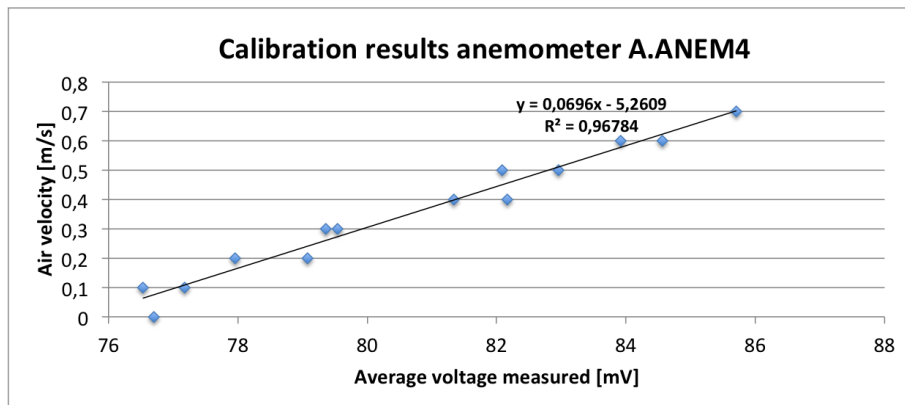

Figure B.5.: Regression analysis on calibration data for anemometer A.ANEM4.

APPENDIX B. CALIBRATION OF THE ANEMOMETERS

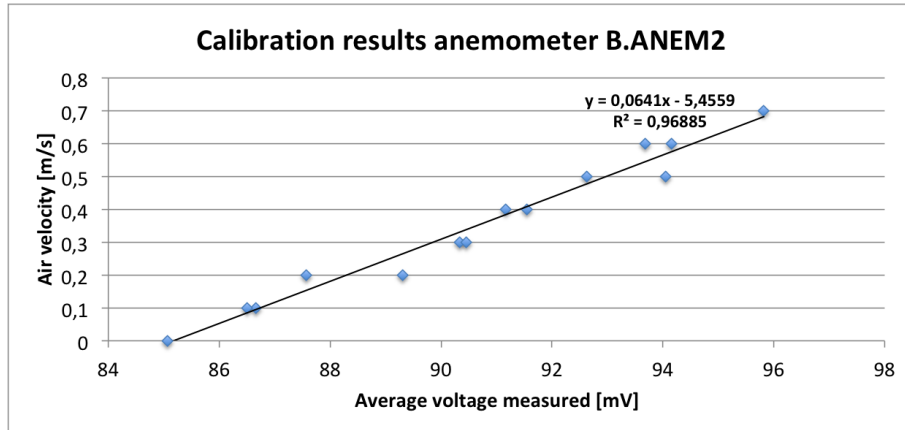

Figure B.6.: Regression analysis on calibration data for anemometer B.ANEM2.

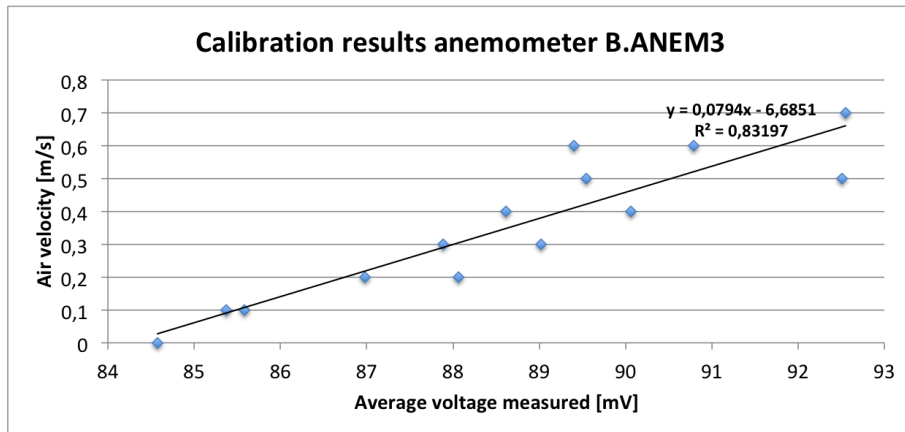

Figure B.7.: Regression analysis on calibration data for anemometer B.ANEM3.

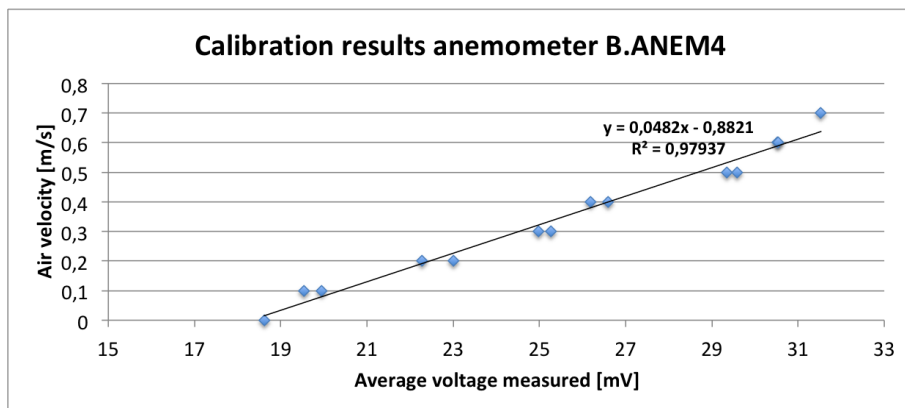

Figure B.8.: Regression analysis on calibration data for anemometer B.ANEM4.

APPENDIX B. CALIBRATION OF THE ANEMOMETERS

Sensor code	Linear regression equation	R ²	Standard error in slope	Standard error in intercept	Standard error in y estimate
A.ANEM2	$y = 0,0553x - 4,4724$	0,86352	0,00662771	0,58166713	0,07580057
A.ANEM3	$y = 0,0802x - 6,5466$	0,89619	0,00788356	0,67786345	0,07174465
A.ANEM4	$y = 0,0696x - 5,2609$	0,96784	0,0036608	0,29543542	0,03993064
B.ANEM2	$y = 0,0641x - 5,4559$	0,96885	0,00331542	0,30069114	0,03929805
B.ANEM3	$y = 0,0794x - 6,6851$	0,83197	0,01029655	0,91299258	0,09127587
B.ANEM4	$y = 0,0482x - 0,8821$	0,97937	0,00201926	0,05232651	0,03198353

Figure B.9.: Best linear fit and correlated deviations.

Sensor code	Input/Output	Raw min	Raw max	Raw unit	Scaled min	Scaled max	Scaled unit	Linear equation correlating [m/s] to [mV]
A.ANEM2	Input	70	322	[mV]	-1	20	[m/s]	$y = 12x + 82$
A.ANEM3	Input	65	317	[mV]	-1	20	[m/s]	$y = 12x + 77$
A.ANEM4	Input	70	322	[mV]	-1	20	[m/s]	$y = 12x + 82$
B.ANEM2	Input	77	329	[mV]	-1	20	[m/s]	$y = 12x + 89$
B.ANEM3	Input	69	321	[mV]	-1	20	[m/s]	$y = 12x + 81$
B.ANEM4	Input	70	322	[mV]	-1	20	[m/s]	$y = 12x + 82$

Figure B.10.: Raw data as included in LabVIEW correlating voltage to velocity.

C. USER EXPERIMENT QUESTIONNAIRE

Feedback from occupants was gathered with a pop-up digital questionnaire. The questions utilized follows.

PART A: START-UP QUESTIONS

Please answer the questions before making any changes to the room or your clothing.

Note down anything that might influence your working day by answering, and if necessary elaborating on, the following question.

1. How did you travel to Test Cell today? Please tick just one box.
 - a) On foot
 - b) Bus
 - c) Car
 - d) Bicycle
 - e) Other
2. How long did it take you to travel to Test Cell today? Please tick just one box.
 - a) 1-10 minutes
 - b) 10-30 minutes
 - c) More than 30 minutes
3. What are the weather conditions today? Describe in a few words below.

APPENDIX C. USER EXPERIMENT QUESTIONNAIRE

4. Describe the garments that you are wearing today by ticking the relevant boxes.

Socks	short	long		
Nylon stockings	flannel stockings	wool stockings		
Shoes	thin soled	thicksoled boots		
T-shirt or similar	short sleeves	long sleeves		
Shirts	short sleeves	long sleeves	flannel shirt	
Trousers	lightweight	normal	thick	
Skirt	light	heavy		
Dress	light	short sleeves	thick	
Sweater	thin	thick		
Jacket	light	normal	down	fleece
Hat				
Scarf				

- Briefly describe below what you plan to do/work on in Test Cell today.
- Describe below your mood. For example, is it good or bad, are you stressed, relaxed, are you tired, or rested?
- Describe below you physical condition. For example are you sick (in what way), in great shape, aching muscles, back etc., hungry or thirsty, hot or cold?
- Other? Describe below.

PART B: MAIN GENERAL QUESTIONS

Based on factors such as experienced physical changes (dry eyes, runny nose, dry skin), temperature, lighting, draughts, air quality, noise, smell and/or other qualities associated with the physical environment,

- How do you rate you thermal sensation? Please tick just one box.

Hot Warm Slightly warm Neutral Slightly cool Cool Cold

- How do you perceive the temperature. Please tick just one box.

Clearly acceptable Just acceptable Just unacceptable Clearly unacceptable

- How do you perceive the air quality. Please tick just one box.

Clearly acceptable Just acceptable Just unacceptable Clearly unacceptable

APPENDIX C. USER EXPERIMENT QUESTIONNAIRE

4. How do you perceive the illuminance for your task. Please tick just one box.

Too dark Slightly dark Just right Slightly bright Too bright

5. Do you experience any of these now?

Dry nose/mouth Dry skin Headache Tiredness Difficulty to concentrate/focus
Other?

6. Optional. Describe the reason for your symptoms below.

7. Have you during the last 30 minutes, made any changes to your working conditions?
For example changed clothing, adjusted anything in the room.

Yes No

8. If yes, what and why? Describe below.

9. Would you, during the last 30 minutes, have liked to make changes to your working conditions?

Yes No

10. If yes, what and why? Describe below.

PART C: END OF THE DAY FINISHING QUESTIONS

Based on factors such as experienced physical changes (dry eyes, runny nose, dry skin), temperature, lighting, draughts, air quality, noise, smell and/or other qualities associated with the physical environment,

1. What has your level of comfort been today. Please tick just one box.

Clearly acceptable Just acceptable Just unacceptable Clearly unacceptable

2. Describe below any actions taken to achieve preferred comfort levels and why you made the changes.

3. Describe below any actions you would have taken, but were unable to do in Test Cell, that would have improved your working conditions?

4. What have you worked on today in Test Cell? Describe below.

5. Describe below you mood. For example, is it good or bad, are you stressed, relaxed, are you tired, or rested?

6. Describe below you physical condition. For example are you sick (in what way), in great shape, aching muscles, back etc., hungry or thirsty, hot or cold?

7. Other? Do you have something you would like to add? Describe below.

D. RISK ASSESSMENT

Next follow the risk assessment completed in advance of the field work to be done at the ZEB Test Cell Laboratory.

NTNU		Prepared by		Number	Date
		HSE section		HMSRV2601E	09.01.2013
HSE		Approved by			Replaces
		The Rector			01.12.2006
Hazardous activity identification process					
					

Unit: Department of Energy and Process Engineering

Date: 14.02.2018

Line manager: Hans Martin Mathisen

Participants in the identification process: Stina Skeie (student) Hans Martin Mathisen, Maria Justo Alonso, Nicola Lollo (supervisors)

Short description of the main activity/main process: Master project for student Stina Skeie.

Thermal comfort and energy use for cooling and heating in non-residential buildings.

Is the project work purely theoretical? (YES/NO): NO

Signatures: Responsible supervisor: 

Student: 

ID nr.	Activity/process	Responsible person	Existing documentation	Existing safety measures	Laws, regulations etc.	Comment
1	Collection of data in ZEB Test Cell Laboratory	Stina Skeie	Not relevant	Not relevant	Not relevant	Downloading data from server
2	Control of measuring equipment ZEB Test Cell Laboratory	Stina Skeie	Not relevant	Not relevant	Not relevant	Less than 10V

NTNU		Prepared by	Number	Date	
		HSE section	HMS/RV/2603E	04.02.2011	
HSE/KS		Approved by	The Rector	Replaces	
				01.12.2006	

Risk assessment

Unit: Department of Energy and Process Engineering

Date: 14.02.2018

Line manager: Hans Martin Mathisen

Participants in the identification process: Stina Skeie (student)

Hans Martin Mathisen, Maria Justo Alonso, Nicola Lollì (supervisors)

Short description of the main activity/main process: Master project for student Stina Skeie. Thermal comfort and energy use for cooling and heating in non-residential buildings.

Signatures: Responsible supervisor:

Stina Skeie

Student: *Stina Skeie*

Activity from the identification process form	Potential undesirable incident/strain	Likelihood:			Consequence:			Risk Value (human)	Comments/status Suggested measures
		Likelihood (1-5)	Human (A-E)	Environment (A-E)	Economy/material (A-E)				
Collection of data in ZEB Test Cell Laboratory		1	A	A	A	A	A1		
Control of measuring equipment ZEB Test Cell Laboratory	Failure in connection	3	A	A	B	A3		Show caution	

Likelihood, e.g.:

1. Minimal
2. Low
3. Medium
4. High
5. Very high

Consequence, e.g.:

- A. Safe
- B. Relatively safe
- C. Dangerous
- D. Critical
- E. Very critical

Risk value (each one to be estimated separately):

Human = Likelihood x Human Consequence

Environmental = Likelihood x Environmental consequence

Financial/material = Likelihood x Consequence for Economy/material

NTNU	Prepared by	Number	Date	
	HSE section	HMSRV2603E	04.02.2011	
HSE/KS	Approved by	The Rector	Replaces 01.12.2006	

Risk assessment

Potential undesirable incident/strain

Identify possible incidents and conditions that may lead to situations that pose a hazard to people, the environment and any materiel/equipment involved.

Criteria for the assessment of likelihood and consequence in relation to fieldwork

Each activity is assessed according to a worst-case scenario. Likelihood and consequence are to be assessed separately for each potential undesirable incident. Before starting on the quantification, the participants should agree what they understand by the assessment criteria:

Likelihood

Minimal 1	Low 2	Medium 3	High 4	Very high 5
Once every 50 years or less	Once every 10 years or less	Once a year or less	Once a month or less	Once a week

Consequence

Grading	Human	Environment	Financial/material
E Very critical	May produce fatality/fies	Very prolonged, non-reversible damage	Shutdown of work > 1 year.
D Critical	Permanent injury, may produce serious serious health damage/sickness	Prolonged damage. Long recovery time.	Shutdown of work 0.5-1 year.
C Dangerous	Serious personal injury	Minor damage. Long recovery time	Shutdown of work < 1 month
B Relatively safe	Injury that requires medical treatment	Minor damage. Short recovery time	Shutdown of work < 1week
A Safe	Injury that requires first aid	Insignificant damage. Short recovery time	Shutdown of work < 1day



The unit makes its own decision as to whether opting to fill in or not consequences for economy/materiel, for example if the unit is going to use particularly valuable equipment. It is up to the individual unit to choose the assessment criteria for this column.

Risk = Likelihood x Consequence

Please calculate the risk value for "Human", "Environment" and, if chosen, "Economy/materiel", separately.

About the column "Comments/status, suggested preventative and corrective measures":

Measures can impact on both likelihood and consequences. Prioritise measures that can prevent the incident from occurring: in other words, likelihood-reducing measures are to be prioritised above greater emergency preparedness, i.e. consequence-reducing measures.

NTNU		prepared by		Number		Date	
		HSE Section		HMSRV2604		8 March 2010	
HSE/KS		approved by		Page		Replaces	
		Rector		4 of 4		9 February 2010	
Risk matrix							

MATRIX FOR RISK ASSESSMENTS at NTNU

CONSEQUENCE		Extremely serious	E1	E2	E3	E4	E5
		Serious	D1	D2	D3	D4	D5
		Moderate	C1	C2	C3	C4	C5
		Minor	B1	B2	B3	B4	B5
		Not significant	A1	A2	A3	A4	A5
		Very low	A1	A2	A3	A4	A5
		Low	A2	A3	A4	A5	A5
		Medium	A3	A4	A5	A5	A5
		High	A4	A5	A5	A5	A5
		Very high	A5	A5	A5	A5	A5
LIKELIHOOD							

Principle for acceptance criteria. Explanation of the colours used in the risk matrix.

Colour	Description
Red	Unacceptable risk. Measures must be taken to reduce the risk.
Yellow	Assessment range. Measures must be considered.
Green	Acceptable risk Measures can be considered based on other considerations.